



S. A.

REPORT  
OF THE  
EIGHTY-SIXTH MEETING OF THE  
BRITISH ASSOCIATION  
FOR THE ADVANCEMENT OF SCIENCE



NEWCASTLE-ON-TYNE: 1916

SEPTEMBER 5—9

LONDON  
JOHN MURRAY, ALBEMARLE STREET  
1917

*Office of the Association: Burlington House, London, W.*



# CONTENTS.

---

	Page
OFFICERS AND COUNCIL, 1916-1917.....	iii
RULES OF THE BRITISH ASSOCIATION.....	v
TABLES: PAST ANNUAL MEETINGS: *	
Trustees, General Officers, &c. (1831-1916) .....	xxi
Sectional Presidents and Secretaries (1901-1915) .....	xxii
Evening Discourses (1901-1915) .....	xxx
Lectures to the Operative Classes and Public Lectures (1901-1915) .....	xxxii
Chairmen and Secretaries of Conferences of Delegates (1901-1915) .....	xxxiii
Grants for Scientific Purposes (1901-1915).....	xxxiv
REPORT OF THE COUNCIL TO THE GENERAL COMMITTEE, 1915-1916 ...	xliv
GENERAL TREASURER'S ACCOUNT, 1915-1916 .....	xlviii
ANNUAL MEETINGS: PLACES AND DATES, PRESIDENTS, ATTENDANCES, RECEIPTS, AND SUMS PAID ON ACCOUNT OF GRANTS FOR SCIENTIFIC PURPOSES (1831-1916) .....	1
ANALYSIS OF ATTENDANCES .....	lii
NEWCASTLE MEETING, 1916:	
General Meetings .....	xli
Sectional Officers .....	xli
Officers of Conference of Delegates .....	xliii
Research Committees .....	liv
Communication ordered to be printed <i>in extenso</i> .....	lxvii
Resolutions referred to the Council .....	lxvii
Synopsis of Grants of Money .....	lxvii
CAIRD FUND .....	lxviii
PUBLIC LECTURES IN NEWCASTLE AND VICINITY .....	lxix

\* Particulars for early Meetings not furnished in the following Tables will be found in Volumes for 1911 and previous years.

	Page
ADDRESS BY THE PRESIDENT, SIR ARTHUR EVANS, D.Litt., LL.D., P.S.A., F.R.S. ....	3
REPORTS ON THE STATE OF SCIENCE, &C. ....	27
TRANSACTIONS OF THE SECTIONS :	
A.—Mathematical and Physical Science .....	355
B.—Chemistry .....	366
C.—Geology .....	378
D.—Zoology .....	403
E.—Geography .....	421
F.—Economic Science and Statistics .....	435
G.—Engineering .....	448
H.—Anthropology .....	458
I.—Physiology .....	470
K.—Botany .....	477
L.—Education .....	512
M.—Agriculture .....	528
REPORT ON THE DETERMINATION OF GRAVITY AT SEA .....	549
REPORT OF THE CORRESPONDING SOCIETIES COMMITTEE AND OF THE CONFERENCE OF DELEGATES OF CORRESPONDING SOCIETIES .....	566
INDEX .....	609
LIST OF PUBLICATIONS .....	625
LIST OF MEMBERS, &C.....	103 pages

#### LIST OF PLATES.

- PLATE I.—Illustrating the Report on Seismological Investigations.
- PLATE II.—Illustrating the Report on the Botanical and Chemical Characters  
of the Eucalypts and their Correlation.
- PLATE III.—Illustrating the Report on Stress Distributions in Engineering  
Materials.
- PLATE IV.—Illustrating Mr. W. Wickham King's Paper on a Plexographic  
Model of the Thick Coal of South Staffordshire.
- PLATES V. AND VI.—Illustrating Mr. E. A. Reeves's Address to the Geographical  
Section.
- PLATES VII.—XVIII.—Illustrating the Report on the Determination of Gravity  
at Sea.



# OFFICERS AND COUNCIL, 1916-1917.

## PATRON.

HIS MAJESTY THE KING.

## PRESIDENT.

SIR ARTHUR EVANS, D.LITT., LL.D., PRES.S.A., F.R.S.

## VICE-PRESIDENTS.

The Right Hon. the LORD MAYOR OF NEWCASTLE.	The Right Hon. LORD RAVENSWORTH.
His Grace the DUKE OF NORTHUMBERLAND, K.G., F.R.S.	The Right Hon. LORD ARMSTRONG.
The Right Hon. the MARQUIS OF LONDONDERRY, M.V.O.	The Right Hon. LORD JOICEY.
The Right Hon. the EARL OF DURHAM, K.G., G.O.V.O.	The Right Rev. the LORD BISHOP OF DURHAM, D.D.
The Right Hon. the EARL OF CRAVEN.	The Right Rev. the LORD BISHOP OF NEWCASTLE, D.D.
The Right Hon. the EARL GREY, G.C.B., G.O.M.G., G.C.V.O.	The Right Hon. J. W. LOWTHER, M.P.
The Right Hon. VISCOUNT ALLENDALE.	The Right Hon. W. RUNCIMAN, M.P.
The Right Hon. VISCOUNT GREY, K.G.	Sir HUGH BELL, Bart.
The Right Hon. LORD BARNARD.	The Hon. Sir CHARLES PARSONS, K.C.B., D.C.L., F.R.S.
	Sir GEORGE H. PHILIPSON, M.D., D.O.L.
	Principal W. H. HADOW, D.Mus.

## PRESIDENT ELECT.

The Hon. Sir CHARLES A. PARSONS, K.C.B., Sc.D., F.R.S.

## GENERAL TREASURER.

Professor JOHN PERRY, D.Sc., LL.D., F.R.S., Burlington House, London, W.

## GENERAL SECRETARIES.

Professor W. A. HERDMAN, D.Sc., LL.D., F.R.S. | Professor H. H. TURNER, D.Sc., D.O.L., F.R.S.

## ASSISTANT SECRETARY.

O. J. R. HOWARTH, M.A., Burlington House, London, W.

## CHIEF CLERK AND ASSISTANT TREASURER.

H. C. STEWARDSON, Burlington House, London, W.

## ORDINARY MEMBERS OF THE COUNCIL.

BONE, Professor W. A., F.R.S.	HALLIBURTON, Professor W. D., F.R.S.
BRABROOK, Sir EDWARD, C.B.	HARMER, Dr. S. F., F.R.S.
BRAGG, Professor W. H., F.R.S.	IM THURN, Sir E. F., K.C.M.G.
CLERK, Dr. DUGALD, F.R.S.	MORRIS, Sir D., K.C.M.G.
DENDY, Professor A., F.R.S.	RUSSELL, Dr. E. J.
DICKSON, Professor H. N., D.Sc.	RUTHERFORD, Sir E., F.R.S.
DIXEY, Dr. F. A., F.R.S.	SAUNDERS, Miss E. R.
DIXON, Professor H. B., F.R.S.	SCOTT, Professor W. R.
DYSON, Sir F. W., F.R.S.	STARLING, Professor E. H., F.R.S.
GREGORY, Professor R. A.	STRAHAN, Dr. A., F.R.S.
GRIFFITHS, Principal E. H., F.R.S.	WEISS, Professor F. E., D.Sc.
HADDON, Dr. A. C., F.R.S.	WOODWARD, Dr. A. SMITH, F.R.S.

## EX-OFFICIO MEMBERS OF THE COUNCIL.

The Trustees, past Presidents of the Association, the President and Vice-Presidents for the year, the President and Vice-Presidents Elect, past and present General Treasurers and General Secretaries, past Assistant General Secretaries, and the Local Treasurers and Local Secretaries for the ensuing Annual Meeting.

## OFFICERS AND COUNCIL.

## TRUSTEES (PERMANENT).

The Right Hon. Lord RAYLEIGH, O.M., M.A., D.C.L., LL.D., F.R.S., F.R.A.S.  
 Major P. A. MACMAHON, D.Sc., LL.D., F.R.S., F.R.A.S.  
 Dr. G. CAREY FOSTER, LL.D., D.Sc., F.R.S.

## PAST PRESIDENTS OF THE ASSOCIATION.

Lord Rayleigh, O.M., F.R.S.	Arthur J. Balfour, O.M., F.R.S.	Sir E. A. Schäfer, F.R.S.
Sir A. Geikie, K.O.B., O.M., F.R.S.	Sir E. Ray Lankester, K.O.B., F.R.S.	Sir Oliver Lodge, F.R.S.
Sir W. Crookes, O.M., F.R.S.	Sir Francis Darwin, F.R.S.	Professor W. Bateson, F.R.S.
Sir James Dewar, F.R.S.	Sir J. J. Thomson, O.M., Pres.R.S.	Professor A. Schuster, F.R.S.
Sir Norman Lockyer, K.O.B., F.R.S.	Professor T. G. Bonney, F.R.S.	

## PAST GENERAL OFFICERS OF THE ASSOCIATION.

Professor T. G. Bonney, F.R.S.	Sir E. A. Schäfer, F.R.S.	Dr. J. G. Garson.
Dr. A. Vernon Harcourt, F.R.S.	Dr. D. H. Scott, F.R.S.	Major P. A. MacMahon, F.R.S.
	Dr. G. Carey Foster, F.R.S.	

## AUDITORS.

Sir Edward Brabrook, C.B. | Sir Everard im Thurn, C.B., K.C.M.G.

---

# RULES OF THE BRITISH ASSOCIATION.

[Adopted by the General Committee at Leicester, 1907,  
with subsequent amendments.]

---

## CHAPTER I.

### *Objects and Constitution.*

1. The objects of the British Association for the Advance- Objects.  
ment of Science are : To give a stronger impulse and a more  
systematic direction to scientific inquiry ; to promote the  
intercourse of those who cultivate Science in different parts  
of the British Empire with one another and with foreign  
philosophers ; to obtain more general attention for the objects  
of Science and the removal of any disadvantages of a public  
kind which impede its progress.

The Association contemplates no invasion of the ground  
occupied by other Institutions.

2. The Association shall consist of Members, Associates, Constitution.  
and Honorary Corresponding Members.

The governing body of the Association shall be a General  
Committee, constituted as hereinafter set forth ; and its  
affairs shall be directed by a Council and conducted by  
General Officers appointed by that Committee.

3. The Association shall meet annually, for one week or Annual  
Meetings.  
longer, and at such other times as the General Committee  
may appoint. The place of each Annual Meeting shall be  
determined by the General Committee not less than two years  
in advance ; and the arrangements for these meetings shall  
be entrusted to the Officers of the Association.

## CHAPTER II.

### *The General Committee.*

1. The General Committee shall be constituted of the Constitution.  
following persons :—

(i) *Permanent Members*—

(a) Past and present Members of the Council, and past  
and present Presidents of the Sections.

(b) Members who, by the publication of works or papers, have furthered the advancement of knowledge in any of those departments which are assigned to the Sections of the Association.

(ii) *Temporary Members*—

- (a) Vice-Presidents and Secretaries of the Sections.
- (b) Honorary Corresponding Members, foreign representatives, and other persons specially invited or nominated by the Council or General Officers.
- (c) Delegates nominated by the Affiliated Societies.
- (d) Delegates—not exceeding altogether three in number—from Scientific Institutions established at the place of meeting.

Admission.

2. The decision of the Council on the qualifications and claims of any Member of the Association to be placed on the General Committee shall be final.

- (i) Claims for admission as a Permanent Member must be lodged with the Assistant Secretary at least one month before the Annual Meeting.
- (ii) Claims for admission as a Temporary Member may be sent to the Assistant Secretary at any time before or during the Annual Meeting.

Meetings.

3. The General Committee shall meet twice at least during every Annual Meeting. In the interval between two Annual Meetings, it shall be competent for the Council at any time to summon a meeting of the General Committee.

Functions.

4. The General Committee shall

- (i) Receive and consider the Report of the Council.
- (ii) Elect a Committee of Recommendations.
- (iii) Receive and consider the Report of the Committee of Recommendations.
- (iv) Determine the place of the Annual Meeting not less than two years in advance.
- (v) Determine the date of the next Annual Meeting.
- (vi) Elect the President and Vice-Presidents, Local Treasurer, and Local Secretaries for the next Annual Meeting.
- (vii) Elect Ordinary Members of Council.
- (viii) Appoint General Officers.
- (ix) Appoint Auditors.
- (x) Elect the Officers of the Conference of Delegates.
- (xi) Receive any notice of motion for the next Annual Meeting.

## CHAPTER III.

*Committee of Recommendations.*

1. \* The *ex officio* Members of the Committee of Recommendations are the President and Vice-Presidents of the Association, the President of each Section at the Annual Meeting, the President of the Conference of Delegates, the General Secretaries, the General Treasurer, the Trustees, and the Presidents of the Association in former years. Constitution.

An Ordinary Member of the Committee for each Section shall be nominated by the Committee of that Section.

If the President of a Section be unable to attend a meeting of the Committee of Recommendations, the Sectional Committee may appoint a Vice-President, or some other member of the Committee, to attend in his place, due notice of such appointment being sent to the Assistant Secretary.

2. Every recommendation made under Chapter IV. and every resolution on a scientific subject, which may be submitted to the Association by any Sectional Committee, or by the Conference of Delegates, or otherwise than by the Council of the Association, shall be submitted to the Committee of Recommendations. If the Committee of Recommendations approve such recommendation, they shall transmit it to the General Committee; and no recommendation shall be considered by the General Committee that is not so transmitted. Functions

Every recommendation adopted by the General Committee shall, if it involve action on the part of the Association, be transmitted to the Council; and the Council shall take such action as may be needful to give effect to it, and shall report to the General Committee not later than the next Annual Meeting.

Every proposal for establishing a new Section or Sub-Section, for altering the title of a Section, or for any other change in the constitutional forms or fundamental rules of the Association, shall be referred to the Committee of Recommendations for their consideration and report.

3. The Committee of Recommendations shall assemble, for the despatch of business, on the Monday of the Annual Meeting, and, if necessary, on the following day. Their Report must be submitted to the General Committee on the last day of the Annual Meeting. Procedure.

\* Amended by the General Committee at Winnipeg, 1909, and Manchester, 1915.

## CHAPTER IV.

*Research Committees.*

Procedure.

1. Every proposal for special research, or for a grant of money in aid of special research, which is made in any Section, shall be considered by the Committee of that Section ; and, if such proposal be approved, it shall be referred to the Committee of Recommendations.

In consequence of any such proposal, a Sectional Committee may recommend the appointment of a Research Committee to conduct research or administer a grant in aid of research, and in any case to report thereon to the Association ; and the Committee of Recommendations may include such recommendation in their report to the General Committee.

Such Research Committee shall be composed of Members of the Association, provided that the Council shall have power to consider, and in its discretion to approve any recommendation to include in such Committee any person, not being a Member of the Association, whose assistance may be regarded as of special importance to the research undertaken.\*

Constitution.

2. Every appointment of a Research Committee shall be proposed at a meeting of the Sectional Committee and adopted at a subsequent meeting. The Sectional Committee shall settle the terms of reference and suitable Members to serve on it, which must be as small as is consistent with its efficient working ; and shall nominate a Chairman and a Secretary. Such Research Committee, if appointed, shall have power to add to their numbers.

Proposals by Sectional Committees.

3. The Sectional Committee shall state in their recommendation whether a grant of money be desired for the purposes of any Research Committee, and shall estimate the amount required.

All proposals sanctioned by a Sectional Committee shall be forwarded by the Recorder to the Assistant Secretary not later than noon on the Monday of the Annual Meeting for presentation to the Committee of Recommendations.

Tenure.

4. Research Committees are appointed for one year only. If the work of a Research Committee cannot be completed in that year, application may be made through a Sectional Committee at the next Annual Meeting for reappointment, with or without a grant—or a further grant—of money.

Reports.

5. Every Research Committee shall present a Report, whether interim or final, at the Annual Meeting next after that at which it was appointed or reappointed, and may in the

\* Amended by the General Committee at Newcastle-upon-Tyne, 1916.

meantime present a Report through a Sectional Organising Committee to the Council.\* Interim Reports, whether intended for publication or not, must be submitted in writing. Each Sectional Committee shall ascertain whether a Report has been made by each Research Committee appointed on their recommendation, and shall report to the Committee of Recommendations on or before the Monday of the Annual Meeting.

6. In each Research Committee to which a grant of money has been made, the Chairman is the only person entitled to call on the General Treasurer for such portion of the sum granted as from time to time may be required.

Grants of money sanctioned at the Annual Meeting expire on June 30 following. The General Treasurer is not authorised, after that date, to allow any claims on account of such grants.

The Chairman of a Research Committee must, before the Annual Meeting next following the appointment of the Research Committee, forward to the General Treasurer a statement of the sums that have been received and expended, together with vouchers. The Chairman must then return the balance of the grant, if any, which remains unexpended; provided that a Research Committee may, in the first year of its appointment only, apply for leave to retain an unexpended balance when or before its Report is presented, due reason being given for such application.†

When application is made for a Committee to be re-appointed, and to retain the balance of a former grant, and also to receive a further grant, the amount of such further grant is to be estimated as being sufficient, together with the balance proposed to be retained, to make up the amount desired.

In making grants of money to Research Committees, the Association does not contemplate the payment of personal expenses to the Members.

A Research Committee, whether or not in receipt of a grant, shall not raise money, in the name or under the auspices of the Association, without special permission from the General Committee.

7. Members and Committees entrusted with sums of money for collecting specimens of any description shall include in their Reports particulars thereof, and shall reserve the specimens thus obtained for disposal, as the Council may direct.

Committees are required to furnish a list of any apparatus which may have been purchased out of a grant made

GRANTS.

(a) Drawn by Chairman.

(b) Expire on June 30.

(c) Accounts, and balance in hand.

(d) Additional Grant.

(e) *Caveat.*

Disposal of specimens, apparatus, &amp;c.

\* Amended by the General Committee at Newcastle-upon-Tyne, 1916.

† Amended by the General Committee at Dundee, 1912.

by the Association, and to state whether the apparatus is likely to be useful for continuing the research in question or for other specific purposes.

All instruments, drawings, papers, and other property of the Association, when not in actual use by a Committee, shall be deposited at the Office of the Association.

## CHAPTER V.

### *The Council.*

#### Constitution.

1. The Council shall consist of *ex officio* Members and of Ordinary Members elected annually by the General Committee.

(i) The *ex officio* Members are—the Trustees, past Presidents of the Association, the President and Vice-Presidents for the year, the President and Vice-Presidents Elect, past and present General Treasurers and General Secretaries, past Assistant General Secretaries, and the Local Treasurers and Local Secretaries for the ensuing Annual Meeting.

(ii) The Ordinary Members shall not exceed twenty-five in number. Of these, not more than twenty shall have served on the Council as Ordinary Members in the previous year.

#### Functions.

2. The Council shall have authority to act, in the name and on behalf of the Association, in all matters which do not conflict with the functions of the General Committee.

In the interval between two Annual Meetings, the Council shall manage the affairs of the Association and may fill up vacancies among the General and other Officers, until the next Annual Meeting.

The Council shall hold such meetings as they may think fit, and shall in any case meet on the first day of the Annual Meeting, in order to complete and adopt the Annual Report, and to consider other matters to be brought before the General Committee.

The Council shall nominate for election by the General Committee, at each Annual Meeting, a President and General Officers of the Association.

Suggestions for the Presidency shall be considered by the Council at the Meeting in February, and the names selected shall be issued with the summonses to the Council Meeting in March, when the nomination shall be made from the names on the list.



The Council shall have power to appoint and dismiss such paid officers as may be necessary to carry on the work of the Association, on such terms as they may from time to time determine. Elections.

3. Election to the Council shall take place at the same time as that of the Officers of the Association.

(i) At each Annual Election, the following Ordinary Members of the Council shall be ineligible for re-election in the ensuing year :

(a) Three of the Members who have served for the longest consecutive period, and

(b) Two of the Members who, being resident in or near London, have attended the least number of meetings during the past year.

Nevertheless, it shall be competent for the Council, by an unanimous vote, to reverse the proportion in the order of retirement above set forth.

(ii) The Council shall submit to the General Committee, in their Annual Report, the names of twenty-three Members of the Association whom they recommend for election as Members of Council.

(iii) Two Members shall be elected by the General Committee, without nomination by the Council ; and this election shall be at the same meeting as that at which the election of the other Members of the Council takes place.

Any member of the General Committee may propose another member thereof for election as one of these two Members of Council, and, if only two are so proposed, they shall be declared elected ; but, if more than two are so proposed, the election shall be by show of hands, unless five Members at least require it to be by ballot.

## CHAPTER VI.

### *The President, General Officers, and Staff.*

1. The President assumes office on the first day of the Annual Meeting, when he delivers a Presidential Address. He resigns office at the next Annual Meeting, when he inducts his successor into the Chair. The President.

The President shall preside at all meetings of the Association or of its Council and Committees which he attends in his capacity as President. In his absence, he shall be represented by a Vice-President or past President of the Association.

General  
Officers.

2. The General Officers of the Association are the General Treasurer and the General Secretaries.

It shall be competent for the General Officers to act, in the name of the Association, in any matter of urgency which cannot be brought under the consideration of the Council ; and they shall report such action to the Council at the next meeting.

The General  
Treasurer.

3. The General Treasurer shall be responsible to the General Committee and the Council for the financial affairs of the Association.

The General  
Secretaries.

4. The General Secretaries shall control the general organisation and administration, and shall be responsible to the General Committee and the Council for conducting the correspondence and for the general routine of the work of the Association, excepting that which relates to Finance.

The Assistant  
Secretary.

5. The Assistant Secretary shall hold office during the pleasure of the Council. He shall act under the direction of the General Secretaries, and in their absence shall represent them. He shall also act on the directions which may be given him by the General Treasurer in that part of his duties which relates to the finances of the Association.

The Assistant Secretary shall be charged, subject as aforesaid : (i) with the general organising and editorial work, and with the administrative business of the Association ; (ii) with the control and direction of the Office and of all persons therein employed ; and (iii) with the execution of Standing Orders or of the directions given him by the General Officers and Council. He shall act as Secretary, and take Minutes, at the meetings of the Council, and at all meetings of Committees of the Council, of the Committee of Recommendations, and of the General Committee.

Assistant  
Treasurer.

6. The General Treasurer may depute one of the Staff, as Assistant Treasurer, to carry on, under his direction, the routine work of the duties of his office.

The Assistant Treasurer shall be charged with the issue of Membership Tickets, the payment of Grants, and such other work as may be delegated to him.

Financial  
Statements.

1. The General Treasurer, or Assistant Treasurer, shall receive and acknowledge all sums of money paid to the Association. He shall submit, at each meeting of the

## CHAPTER VII.

### *Finance.*

Council, an interim statement of his Account; and, after June 30 in each year, he shall prepare and submit to the General Committee a balance-sheet of the Funds of the Association.

2. The Accounts of the Association shall be audited, annually, by Auditors appointed by the General Committee. Audit.

3. The General Treasurer shall make all ordinary payments authorised by the General Committee or by the Council. Expenditure.

4. The General Treasurer is empowered to draw on the account of the Association, and to invest on its behalf, part or all of the balance standing at any time to the credit of the Association in the books of the Bank of England, either in Exchequer Bills or in any other temporary investment, and to change, sell, or otherwise deal with such temporary investment as may seem to him desirable. Investments.

5. In the event of the General Treasurer being unable, from illness or any other cause, to exercise the functions of his office, the President of the Association for the time being and one of the General Secretaries shall be jointly empowered to sign cheques on behalf of the Association. Cheques.

## CHAPTER VIII.

### *The Annual Meetings.*

1. Local Committees shall be formed to assist the General Officers in making arrangements for the Annual Meeting, and shall have power to add to their number. Local Officers and Committees.

2. The General Committee shall appoint, on the recommendation of the Local Reception or Executive Committee for the ensuing Annual Meeting, a Local Treasurer or Treasurers and two or more Local Secretaries, who shall rank as officers of the Association, and shall consult with the General Officers and the Assistant Secretary as to the local arrangements necessary for the conduct of the meeting. The Local Treasurers shall be empowered to enrol Members and Associates, and to receive subscriptions.

3. The Local Committees and Sub-Committees shall undertake the local organisation, and shall have power to act in the name of the Association in all matters pertaining to the local arrangements for the Annual Meeting other than the work of the Sections. Functions.

## CHAPTER IX.

*The Work of the Sections.*THE  
SECTIONS.

1. The scientific work of the Association shall be transacted under such Sections as shall be constituted from time to time by the General Committee.

It shall be competent for any Section, if authorised by the Council for the time being, to form a Sub-Section for the purpose of dealing separately with any group of communications addressed to that Section.

Sectional  
Officers.

2. There shall be in each Section a President, two or more Vice-Presidents, and two or more Secretaries. They shall be appointed by the Council, for each Annual Meeting in advance, and shall act as the Officers of the Section from the date of their appointment until the appointment of their successors in office for the ensuing Annual Meeting.

Of the Secretaries, one shall act as Recorder of the Section, and one shall be resident in the locality where the Annual Meeting is held.

Rooms.

3. The Section Rooms and the approaches thereto shall not be used for any notices, exhibitions, or other purposes than those of the Association.

SECTIONAL  
COMMITTEES.

4. The work of each Section shall be conducted by a Sectional Committee, which shall consist of the following :—

Constitution.

- (i) The Officers of the Section during their term of office.
- (ii) All past Presidents of that Section.
- (iii) Such other Members of the Association, present at any Annual Meeting, as the Sectional Committee, thus constituted, may co-opt for the period of the meeting :

*Provided always that—*

Privilege of  
Old Members.

- (a) Any Member of the Association who has served on the Committee of any Section in any previous year, and who has intimated his intention of being present at the Annual Meeting, is eligible as a member of that Committee at their first meeting.

Daily  
Co-optation.

- (b) A Sectional Committee may co-opt members, as above set forth, at any time during the Annual Meeting, and shall publish daily a revised list of the members.

- (c) A Sectional Committee may, at any time during the Annual Meeting, appoint not more than three persons present at the meeting to be Vice-Presidents of the Section, in addition to those previously appointed by the Council.

Additional  
Vice-Presi-  
dents.

5. The chief executive officers of a Section shall be the President and the Recorder. They shall have power to act on behalf of the Section in any matter of urgency which cannot be brought before the consideration of the Sectional Committee; and they shall report such action to the Sectional Committee at its next meeting.

EXECUTIVE  
FUNCTIONS

The President (or, in his absence, one of the Vice-Presidents) shall preside at all meetings of the Sectional Committee or of the Section. His ruling shall be absolute on all points of order that may arise.

Of President

The Recorder shall be responsible for the punctual transmission to the Assistant Secretary of the daily programme of his Section, of the recommendations adopted by the Sectional Committee, of the printed returns, abstracts, reports, or papers appertaining to the proceedings of his Section at the Annual Meeting, and for the correspondence and minutes of the Sectional Committee.

and of  
Recorder.

6. The Sectional Committee shall nominate, before the close of the Annual Meeting, not more than six of its own members to be members of an Organising Committee, with the officers to be subsequently appointed by the Council, and past Presidents of the Section, from the close of the Annual Meeting until the conclusion of its meeting on the first day of the ensuing Annual Meeting.

Organising  
Committee.

Each Organising Committee shall hold such meetings as are deemed necessary by its President for the organisation of the ensuing Sectional proceedings, and may at any such meeting resolve to present a report to the Council upon any matter of interest to the Section,\* and shall hold a meeting on the first Wednesday of the Annual Meeting: to nominate members of the Sectional Committee, to confirm the Provisional Programme of the Section, and to report to the Sectional Committee.

Each Sectional Committee shall meet daily, unless otherwise determined, during the Annual Meeting: to co-opt members, to complete the arrangements for the next day, and to take into consideration any suggestion for the advancement of Science that may be offered by a member, or may arise out of the proceedings of the Section.

Sectional  
Committee.

\* Amended by the General Committee at Newcastle-upon-Tyne, 1916.

Papers and  
Reports.

No paper shall be read in any Section until it has been accepted by the Sectional Committee and entered as accepted on its Minutes.

Any report or paper read in any one Section may be read also in any other Section.

No paper or abstract of a paper shall be printed in the Annual Report of the Association unless the manuscript has been received by the Recorder of the Section before the close of the Annual Meeting.

Recommendations.

It shall be within the competence of the Sectional Committee to review the recommendations adopted at preceding Annual Meetings, as published in the Annual Reports of the Association, and the communications made to the Section at its current meetings, for the purpose of selecting definite objects of research, in the promotion of which individual or concerted action may be usefully employed ; and, further, to take into consideration those branches or aspects of knowledge on the state and progress of which reports are required : to make recommendations and nominate individuals or Research Committees to whom the preparation of such reports, or the task of research, may be entrusted, discriminating as to whether, and in what respects, these objects may be usefully advanced by the appropriation of money from the funds of the Association, whether by reference to local authorities, public institutions, or Departments of His Majesty's Government. The appointment of such Research Committees shall be made in accordance with the provisions of Chapter IV.

No proposal arising out of the proceedings of any Section shall be referred to the Committee of Recommendations unless it shall have received the sanction of the Sectional Committee.

Publication.

7. Papers ordered to be printed *in extenso* shall not be included in the Annual Report, if published elsewhere prior to the issue of the Annual Report in volume form. Reports of Research Committees shall not be published elsewhere than in the Annual Report without the express sanction of the Council.

Copyright.

8. The copyright of papers ordered by the General Committee to be printed *in extenso* in the Annual Report shall be vested in the authors ; and the copyright of the reports of Research Committees appointed by the General Committee shall be vested in the Association.

## CHAPTER X.

*Admission of Members and Associates.*

1. No technical qualification shall be required on the part of an applicant for admission as a Member or as an Associate of the British Association; but the Council is empowered, in the event of special circumstances arising, to impose suitable conditions and restrictions in this respect. Applications.

\* Every person admitted as a Member or an Associate shall conform to the Rules and Regulations of the Association, any infringement of which on his part may render him liable to exclusion by the Council, who have also authority, if they think it necessary, to withhold from any person the privilege of attending any Annual Meeting or to cancel a ticket of admission already issued. Obligations.

It shall be competent for the General Officers to act, in the name of the Council, on any occasion of urgency which cannot be brought under the consideration of the Council; and they shall report such action to the Council at the next meeting.

2. All Members are eligible to any office in the Association. Conditions and Privileges of Membership.

(i) Every *Life Member* shall pay, on admission, the sum of Ten Pounds.

Life Members shall receive *gratis* the Annual Reports of the Association.

(ii) Every *Annual Member* shall pay, on admission, the sum of Two Pounds, and in any subsequent year the sum of One Pound.

Annual Members shall receive *gratis* the Report of the Association for the year of their admission and for the years in which they continue to pay, *without intermission*, their annual subscription. An Annual Member who omits to subscribe for any particular year shall lose for that and all future years the privilege of receiving the Annual Reports of the Association *gratis*. He, however, may resume his other privileges as a Member at any subsequent Annual Meeting by paying on each such occasion the sum of One Pound.

(iii) Every *Associate* for a year shall pay, on admission, the sum of One Pound.

\* Amended by the General Committee at Dublin, 1908.

Associates shall not receive the Annual Report gratuitously. They shall not be eligible to serve on any Committee, nor be qualified to hold any office in the Association.

- (iv) *Ladies* may become Members or Associates on the same terms as gentlemen, or can obtain a *Lady's Ticket* (transferable to ladies only) on the payment of One Pound.

Corresponding Members.

3. Corresponding Members may be appointed by the General Committee, on the nomination of the Council. They shall be entitled to all the privileges of Membership.

Annual Subscriptions.

4. Subscriptions are payable at or before the Annual Meeting. Annual Members not attending the meeting may make payment at any time before the close of the financial year on June 30 of the following year.

The Annual Report.

5. The Annual Report of the Association shall be forwarded *gratis* to individuals and institutions entitled to receive it.

Annual Members whose subscriptions have been intermitted shall be entitled to purchase the Annual Report at two-thirds of the publication price; and Associates for a year shall be entitled to purchase, at the same price, the volume for that year.

Volumes not claimed within two years of the date of publication can only be issued by direction of the Council.

## CHAPTER XI.

### *Corresponding Societies: Conference of Delegates.*

Corresponding Societies are constituted as follows:

AFFILIATED SOCIETIES.

1. (i) Any Society which undertakes local scientific investigation and publishes the results may become a Society *affiliated* to the British Association.

Each Affiliated Society may appoint a Delegate, who must be or become a Member of the Association and must attend the meetings of the Conference of Delegates. He shall be *ex officio* a Member of the General Committee.

ASSOCIATED SOCIETIES.

- (ii) Any Society formed for the purpose of encouraging the study of Science, which has existed for three years and numbers not fewer than fifty members, may become a Society *associated* with the British Association.



Each Associated Society shall have the right to appoint a Delegate to attend the Annual Conference. Such Delegates must be or become either Members or Associates of the British Association, and shall have all the rights of Delegates appointed by the Affiliated Societies, except that of membership of the General Committee.

2. Application may be made by any Society to be placed on the list of Corresponding Societies. Such application must be addressed to the Assistant Secretary on or before the 1st of June preceding the Annual Meeting at which it is intended it should be considered, and must, in the case of Societies desiring to be affiliated, be accompanied by specimens of the publications of the results of local scientific investigations recently undertaken by the Society. Applications.

3. A Corresponding Societies Committee shall be annually nominated by the Council and appointed by the General Committee, for the purpose of keeping themselves generally informed of the work of the Corresponding Societies and of superintending the preparation of a list of the papers published by the Affiliated Societies. This Committee shall make an Annual Report to the Council, and shall suggest such additions or changes in the list of Corresponding Societies as they may consider desirable. CORRESPONDING SOCIETIES COMMITTEE.

(i) Each Corresponding Society shall forward every year to the Assistant Secretary of the Association, on or before June 1, such particulars in regard to the Society as may be required for the information of the Corresponding Societies Committee. Procedure.

(ii) There shall be inserted in the Annual Report of the Association a list of the papers published by the Corresponding Societies during the preceding twelve months which contain the results of local scientific work conducted by them—those papers only being included which refer to subjects coming under the cognisance of one or other of the several Sections of the Association.

4. The Delegates of Corresponding Societies shall constitute a Conference, of which the President,\* Vice-President,\* and Secretary or Secretaries shall be nominated annually by the Council and appointed by the General Committee. The members of the Corresponding Societies Committee shall be *ex officio* members of the Conference. CONFERENCE OF DELEGATES.

\* Amended by the General Committee at Manchester, 1915.

Procedure and  
Functions.

- (i) The Conference of Delegates shall be summoned by the Secretaries to hold one or more meetings during each Annual Meeting of the Association, and shall be empowered to invite any Member or Associate to take part in the discussions.
- (ii) The Conference of Delegates shall be empowered to submit Resolutions to the Committee of Recommendations for their consideration, and for report to the General Committee.
- (iii) The Sectional Committees of the Association shall be requested to transmit to the Secretaries of the Conference of Delegates copies of any recommendations to be made to the General Committee bearing on matters in which the co-operation of Corresponding Societies is desirable. It shall be competent for the Secretaries of the Conference of Delegates to invite the authors of such recommendations to attend the meetings of the Conference in order to give verbal explanations of their objects and of the precise way in which they desire these to be carried into effect.
- (iv) It shall be the duty of the Delegates to make themselves familiar with the purport of the several recommendations brought before the Conference, in order that they may be able to bring such recommendations adequately before their respective Societies.
- (v) The Conference may also discuss propositions regarding the promotion of more systematic observation and plans of operation, and of greater uniformity in the method of publishing results.

## CHAPTER XII.

### *Amendments and New Rules.*

Alterations.

Any alterations in the Rules, and any amendments or new Rules that may be proposed by the Council or individual Members, shall be notified to the General Committee on the first day of the Annual Meeting, and referred forthwith to the Committee of Recommendations; and, on the report of that Committee, shall be submitted for approval at the last meeting of the General Committee.

## TRUSTEES, GENERAL OFFICERS, &amp;c., 1831-1916.

## TRUSTEES.

1832-70 (Sir) R. I. MURCHISON (Bart.), F.R.S.	1872-1913 { Sir J. LUBBOCK, Bart. (after- wards Lord AVEBURY), F.R.S.
1832-62 JOHN TAYLOR, Esq., F.R.S.	1881-83 W. SPOTTISWOODE, Esq., Pres. R.S.
1832-39 C. BABBAGE, Esq., F.R.S.	1883- Lord RAYLEIGH, F.R.S.
1839-44 F. BAILY, Esq., F.R.S.	1883-98 Sir LYON (afterwards Lord) PLAYFAIR, F.R.S.
1844-58 Rev. G. PEACOCK, F.R.S.	1898-1915 Prof. (Sir) A. W. RÜCKER, F.R.S.
1858-82 General E. SABINE, F.R.S.	1913- Major P. A. MACMAHON, F.R.S.
1862-81 Sir P. EGERTON, Bart., F.R.S.	1915- Dr. G. CAREY FOSTER, F.R.S.

## GENERAL TREASURERS.

1831 JONATHAN GRAY, Esq.	1891-98 Prof. (Sir) A. W. RÜCKER, F.R.S.
1832-62 JOHN TAYLOR, Esq., F.R.S.	1898-1904 Prof. G. C. FOSTER, F.R.S.
1862-74 W. SPOTTISWOODE, Esq., F.R.S.	1904- Prof. JOHN PERRY, F.R.S.
1874-91 Prof. A. W. WILLIAMSON, F.R.S.	

## GENERAL SECRETARIES.

1832-35 Rev. W. VERNON HARCOURT, F.R.S.	1871-72 Dr. T. THOMSON, F.R.S., and Capt. DOUGLAS GALTON, F.R.S.
1835-36 Rev. W. VERNON HARCOURT, F.R.S., and F. BAILY, Esq., F.R.S.	1872-76 Capt. D. GALTON, F.R.S., and Dr. MICHAEL FOSTER, F.R.S.
1836-37 Rev. W. VERNON HARCOURT, F.R.S., and R. I. MURCHISON, Esq., F.R.S.	1876-81 Capt. D. GALTON, F.R.S., and Dr. P. L. SCLATER, F.R.S.
1837-39 R. I. MURCHISON, Esq., F.R.S., and Rev. G. PEACOCK, F.R.S.	1881-82 Capt. D. GALTON, F.R.S., and Prof. F. M. BALFOUR, F.R.S.
1839-45 Sir R. I. MURCHISON, F.R.S., and Major E. SABINE, F.R.S.	1882-83 Capt. DOUGLAS GALTON, F.R.S.
1845-50 Lieut.-Colonel E. SABINE, F.R.S.	1883-95 Sir DOUGLAS GALTON, F.R.S., and A. G. VERNON HARCOURT, Esq., F.R.S.
1850-52 General E. SABINE, F.R.S., and J. F. ROYLE, Esq., F.R.S.	1895-97 A. G. VERNON HARCOURT, Esq., F.R.S., and Prof. E. A. SCHÄFER, F.R.S.
1852-53 J. F. ROYLE, Esq., F.R.S.	1897- { Prof. SCHÄFER, F.R.S., and Sir 1900 { W. C. ROBERTS-AUSTEN, F.R.S.
1853-59 General E. SABINE, F.R.S.	1900-02 Sir W. C. ROBERTS-AUSTEN, F.R.S., and Dr. D. H. SCOTT, F.R.S.
1859-61 Prof. R. WALKER, F.R.S.	1902-03 Dr. D. H. SCOTT, F.R.S., and Major P. A. MACMAHON, F.R.S.
1861-62 W. HOPKINS, Esq., F.R.S.	1903-13 Major P. A. MACMAHON, F.R.S., and Prof. W. A. HERDMAN, F.R.S.
1862-63 W. HOPKINS, Esq., F.R.S., and Prof. J. PHILLIPS, F.R.S.	1913- Prof. W. A. HERDMAN, F.R.S., and Prof. H. H. TURNER, F.R.S.
1863-65 W. HOPKINS, Esq., F.R.S., and F. GALTON, Esq., F.R.S.	
1865-66 F. GALTON, Esq., F.R.S.	
1866-68 F. GALTON, Esq., F.R.S., and Dr. T. A. HIRST, F.R.S.	
1868-71 Dr. T. A. HIRST, F.R.S., and Dr. T. THOMSON, F.R.S.	

## ASSISTANT GENERAL SECRETARIES, &amp;c.: 1831-1904.

1831 JOHN PHILLIPS, Esq., <i>Secretary</i> .	1881-85 Prof. T. G. BONNEY, F.R.S., <i>Secretary</i> .
1832 Prof. J. D. FORBES, <i>Acting</i> <i>Secretary</i> .	1885-90 A. T. ATCHISON, Esq., M.A., <i>Secretary</i> .
1832-62 Prof. JOHN PHILLIPS, F.R.S.	1890 G. GRIFFITH, Esq., M.A., <i>Acting</i> <i>Secretary</i> .
1862-78 G. GRIFFITH, Esq., M.A.	1890-1902 G. GRIFFITH, Esq., M.A.
1881 G. GRIFFITH, Esq., M.A., <i>Acting</i> <i>Secretary</i> .	1902-04 J. G. GARSON, Esq., M.D.

## ASSISTANT SECRETARIES.

1878-80 J. E. H. GORDON, Esq., B.A.	1909- O. J. R. HOWARTH, Esq., M.A.
1904-09 A. SILVA WHITE, Esq.	

*Presidents and Secretaries of the Sections of the Association,  
1901-1915.*

(The List of Sectional Officers for 1916 will be found on p. xli.)

Date and Place	Presidents	Secretaries ( <i>Rec.</i> = Recorder)
<b>SECTION A.<sup>1</sup>—MATHEMATICS AND PHYSICS.</b>		
1901. Glasgow ...	Major P. A. MacMahon, F.R.S. — <i>Dep. of Astronomy</i> , Prof. H. H. Turner, F.R.S.	H. S. Carslaw, C. H. Lees ( <i>Rec.</i> ), W. Stewart, Prof. L. R. Wilberforce.
1902. Belfast.....	Prof. J. Purser, L.L.D., M.R.I.A. — <i>Dep. of Astronomy</i> , Prof. A. Schuster, F.R.S.	H. S. Carslaw, A. R. Hinks, A. Larmor, C. H. Lees ( <i>Rec.</i> ), Prof. W. B. Morton, A. W. Porter.
1903. Southport	C. Vernon Boys, F.R.S.— <i>Dep.</i> <i>of Astronomy and Meteor-</i> <i>ology</i> , Dr. W. N. Shaw, F.R.S.	D. E. Benson, A. R. Hinks, R. W. H. T. Hudson, Dr. C. H. Lees ( <i>Rec.</i> ), J. Loton, A. W. Porter.
1904. Cambridge	Prof. H. Lamb, F.R.S.— <i>Sub-</i> <i>Section of Astronomy and</i> <i>Cosmical Physics</i> , Sir J. Eliot, K.C.I.E., F.R.S.	A. R. Hinks, R. W. H. T. Hudson, Dr. C. H. Lees ( <i>Rec.</i> ), Dr. W. J. S. Lockyer, A. W. Porter, W. C. D. Whetham.
1905. South Africa	Prof. A. R. Forsyth, M.A., F.R.S.	A. R. Hinks, S. S. Hough, R. T. A. Innes, J. H. Jeans, Dr. C. H. Lees ( <i>Rec.</i> ).
1906. York.....	Principal E. H. Griffiths, F.R.S.	Dr. L. N. G. Filon, Dr. J. A. Harker, A. R. Hinks, Prof. A. W. Porter ( <i>Rec.</i> ), H. Dennis Taylor.
1907. Leicester ...	Prof. A. E. H. Love, M.A., F.R.S.	E. E. Brooks, Dr. L. N. G. Filon, Dr. J. A. Harker, A. R. Hinks, Prof. A. W. Porter ( <i>Rec.</i> ).
1908. Dublin .....	Dr. W. N. Shaw, F.R.S. ....	Dr. W. G. Duffield, Dr. L. N. G. Filon, E. Gold, Prof. J. A. McClelland, Prof. A. W. Porter ( <i>Rec.</i> ), Prof. E. T. Whittaker.
1909. Winnipeg	Prof. E. Rutherford, F.R.S....	Prof. F. Allen, Prof. J. C. Fields, E. Gold, F. Horton, Prof. A. W. Porter ( <i>Rec.</i> ), Dr. A. A. Rambaut.
1910. Sheffield ...	Prof. E. W. Hobson, F.R.S....	H. Bateman, A. S. Eddington, E. Gold, Dr. F. Horton, Dr. S. R. Milner, Prof. A. W. Porter ( <i>Rec.</i> ).
1911. Portsmouth	Prof. H. H. Turner, F.R.S. ...	H. Bateman, Prof. P. V. Bevan, A. S. Eddington, E. Gold, Prof. A. W. Porter ( <i>Rec.</i> ), P. A. Yapp.
1912. Dundee ...	Prof. H. L. Callendar, F.R.S.	Prof. P. V. Bevan, E. Gold, Dr. H. B. Heywood, R. Norrie, Prof. A. W. Porter ( <i>Rec.</i> ), W. G. Robson, F. J. M. Stratton.
1913. Birmingham	Dr. H. F. Baker, F.R.S. ....	Prof. P. V. Bevan ( <i>Rec.</i> ), Prof. A. S. Eddington, E. Gold, Dr. H. B. Heywood, Dr. A. O. Rankine, Dr. G. A. Shakespear.
1914. Australia ...	Prof. F. T. Trouton, F.R.S....	Prof. A. S. Eddington ( <i>Rec.</i> ), E. Gold, Prof. T. R. Lyle, F.R.S., Prof. S. B. McLaren, Prof. J. A., Pollock, Dr. A. O. Rankine.
1915. Manchester	Sir F. W. Dyson, F.R.S. ...	Prof. A. S. Eddington, F.R.S. ( <i>Rec.</i> ), E. Gold, Dr. Makower, Dr. A. O. Rankine.

<sup>1</sup> Section A was constituted under this title in 1835, when the sectional division was introduced. The previous division was into 'Committees of Sciences.'

Date and Place	Presidents	Secretaries ( <i>Rec.</i> = Recorder)
<b>SECTION B.<sup>2</sup>—CHEMISTRY.</b>		
1901. Glasgow ...	Prof. Percy F. Frankland, F.R.S.	W. C. Anderson, G. G. Henderson, W. J. Pope, T. K. Rose ( <i>Rec.</i> ).
1902. Belfast .....	Prof. E. Divers, F.R.S.....	R. F. Blake, M. O. Forster, Prof. G. G. Henderson, Prof. W. J. Pope ( <i>Rec.</i> ).
1903. Southport	Prof. W. N. Hartley, D.Sc., F.R.S.	Dr. M. O. Forster, Prof. G. G. Henderson, J. Ohm, Prof. W. J. Pope ( <i>Rec.</i> ).
1904. Cambridge	Prof. Sydney Young, F.R.S....	Dr. M. O. Forster, Prof. G. G. Henderson, Dr. H. O. Jones, Prof. W. J. Pope ( <i>Rec.</i> ).
1905. SouthAfrica	George T. Beilby .....	W. A. Caldecott, Mr. M. O. Forster, Prof. G. G. Henderson ( <i>Rec.</i> ), C. F. Juritz.
1906. York.....	Prof. Wyndham R. Dunstan, F.R.S.	Dr. E. F. Armstrong, Prof. A. W. Crossley, S. H. Davies, Prof. W. J. Pope ( <i>Rec.</i> ).
1907. Leicester ...	Prof. A. Smithells, F.R.S. ...	Dr. E. F. Armstrong, Prof. A. W. Crossley ( <i>Rec.</i> ), J. H. Hawthorn, Dr. F. M. Perkin.
1908. Dublin .....	Prof. F. S. Kipping, F.R.S. ...	Dr. E. F. Armstrong ( <i>Rec.</i> ), Dr. A. McKenzie, Dr. F. M. Perkin, Dr. J. H. Pollock.
1909. Winnipeg...	Prof. H. E. Armstrong, F.R.S.	Dr. E. F. Armstrong ( <i>Rec.</i> ), Dr. T. M. Lowry, Dr. F. M. Perkin, J. W. Shipley.
1910. Sheffield ...	J. E. Stead, F.R.S. ....	Dr. E. F. Armstrong ( <i>Rec.</i> ), Dr. T. M. Lowry, Dr. F. M. Perkin, W. E. S. Turner.
	<i>Sub-section of Agriculture—</i> A. D. Hall, F.R.S.	Dr. C. Crowther, J. Golding, Dr. E. J. Russell.
1911. Portsmouth	Prof. J. Walker, F.R.S. ....	Dr. E. F. Armstrong ( <i>Rec.</i> ), Dr. C. H. Desch, Dr. T. M. Lowry, Dr. F. Beddow.
1912. Dundee ...	Prof. A. Senior, M.D. ....	Dr. E. F. Armstrong ( <i>Rec.</i> ), Dr. C. H. Desch, Dr. A. Holt, Dr. J. K. Wood.
1913. Birmingham	Prof. W. P. Wynne, F.R.S. ...	Dr. E. F. Armstrong ( <i>Rec.</i> ), Dr. C. H. Desch, Dr. A. Holt, Dr. H. McCombie.
1914. Australia ...	Prof. W. J. Pope, F.R.S. ....	D. Avery, Prof. C. Fawsitt, Dr. A. Holt ( <i>Rec.</i> ), Dr. N. V. Sidgwick.
1915. Manchester	Prof. W. A. Bone, F.R.S. ...	Dr. H. F. Coward, Dr. C. H. Desch, Dr. A. Holt ( <i>Rec.</i> ).

SECTION C.<sup>3</sup>—GEOLOGY.

1901. Glasgow ...	John Horne, F.R.S. ....	H. L. Bowman, H. W. Monckton ( <i>Rec.</i> ).
1902. Belfast .....	Lieut.-Gen. C. A. McMahon, F.R.S.	H. L. Bowman, H. W. Monckton ( <i>Rec.</i> ), J. St. J. Phillips, H. J. Seymour.

<sup>2</sup> 'Chemistry and Mineralogy,' 1835-1894.<sup>3</sup> 'Geology and Geography,' 1835-1850.

Date and Place	Presidents	Secretaries ( <i>Rec.</i> = Recorder)
1903. Southport	Prof. W. W. Watts, M.A., M.Sc.	H. L. Bowman, Rev. W. L. Carter, J. Lomas, H. W. Monckton ( <i>Rec.</i> ).
1904. Cambridge	Aubrey Strahan, F.R.S. ....	H. L. Bowman ( <i>Rec.</i> ), Rev. W. L. Carter, J. Lomas, H. Woods.
1905. SouthAfrica	Prof. H. A. Miers, M.A., D.Sc., F.R.S.	H. L. Bowman ( <i>Rec.</i> ), J. Lomas, Dr. Molengraaff, Prof. A. Young, Prof. R. B. Young.
1906. York.....	G. W. Lamplugh, F.R.S. ....	H. L. Bowman ( <i>Rec.</i> ), Rev. W. L. Carter, Rev. W. Johnson, J. Lomas.
1907. Leicester ...	Prof. J. W. Gregory, F.R.S....	Dr. F. W. Bennett, Rev. W. L. Carter, Prof. T. Groom, J. Lomas ( <i>Rec.</i> ).
1908. Dublin.....	Prof. John Joly, F.R.S. ....	Rev. W. L. Carter, J. Lomas ( <i>Rec.</i> ), Prof. S. H. Reynolds, H. J. Sey- mour.
1909. Winnipeg...	Dr. A. Smith Woodward, F.R.S.	W. L. Carter ( <i>Rec.</i> ), Dr. A. R. Dwerry- house, R. T. Hodgson, Prof. S. H. Reynolds.
1910. Sheffield ...	Prof. A. P. Coleman, F.R.S....	W. L. Carter ( <i>Rec.</i> ), Dr. A. R. Dwerry- house, B. Hobson, Prof. S. H. Reynolds.
1911. Portsmouth	A. Harker, F.R.S. ....	Col. C. W. Bevis, W. L. Carter ( <i>Rec.</i> ), Dr. A. R. Dwerryhouse, Prof. S. H. Reynolds.
1912. Dundee ...	Dr. B. N. Peach, F.R.S. ....	Prof. W. B. Boulton, A. W. R. Don, Dr. A. R. Dwerryhouse ( <i>Rec.</i> ), Prof. S. H. Reynolds.
1913. Birmingham	Prof. E. J. Garwood, M.A. ...	Prof. W. S. Boulton, Dr. A. R. Dwerryhouse ( <i>Rec.</i> ), F. Raw, Prof. S. H. Reynolds.
1914. Australia ...	Prof. Sir T. H. Holland, F.R.S.	Dr. A. R. Dwerryhouse ( <i>Rec.</i> ), E. F. Pittman, Prof. S. H. Reynolds, Prof. E. W. Skeats.
1915. Manchester	Prof. Grenville A. J. Cole ...	W. Lower Carter ( <i>Rec.</i> ), Dr. W. T. Gordon, Dr. G. Hickling, Dr. D. M. S. Watson.

SECTION D.<sup>4</sup>—ZOOLOGY.

1901. Glasgow ...	Prof. J. Cossar Ewart, F.R.S.	J. G. Kerr ( <i>Rec.</i> ), J. Rankin, J. Y. Simpson.
1902. Belfast.....	Prof. G. B. Howes, F.R.S. ...	Prof. J. G. Kerr, R. Patterson, J. Y. Simpson ( <i>Rec.</i> ).
1903. Southport	Prof. S. J. Hickson, F.R.S. ...	Dr. J. H. Ashworth, J. Barcroft, A. Quayle, Dr. J. Y. Simpson ( <i>Rec.</i> ), Dr. H. W. M. Tims.
1904. Cambridge	William Bateson, F.R.S. ....	Dr. J. H. Ashworth, L. Doncaster, Prof. J. Y. Simpson ( <i>Rec.</i> ), Dr. H. W. M. Tims.
1905. SouthAfrica	G. A. Boulenger, F.R.S. ....	Dr. Pakes, Dr. Purcell, Dr. H. W. M. Tims, Prof. J. Y. Simpson ( <i>Rec.</i> ).
1906. York.....	J. J. Lister, F.R.S. ....	Dr. J. H. Ashworth, L. Doncaster, Oxley Grabham, Dr. H. W. M. Tims ( <i>Rec.</i> ).
1907. Leicester ...	Dr. W. E. Hoyle, M.A.....	Dr. J. H. Ashworth, L. Doncaster, E. E. Lowe, Dr. H. W. M. Tims ( <i>Rec.</i> ).

<sup>4</sup> 'Zoology and Botany,' 1835-1847; 'Zoology and Botany, including Physiology,' 1848-1865; 'Biology,' 1866-1894.

Date and Place	Presidents	Secretaries ( <i>Rec.</i> = Recorder)
1908. Dublin.....	Dr. S. F. Harmer, F.R.S.....	Dr. J. H. Ashworth, L. Doncaster, Prof. A. Fraser, Dr. H. W. M. Tims ( <i>Rec.</i> ).
1909. Winnipeg...	Dr. A. E. Shipley, F.R.S. ...	C. A. Baragar, C. L. Boulenger, Dr. J. Pearson, Dr. H. W. M. Tims ( <i>Rec.</i> ).
1910. Sheffield ...	Prof. G. C. Bourne, F.R.S. ...	Dr. J. H. Ashworth, L. Doncaster, T. J. Evans, Dr. H. W. M. Tims ( <i>Rec.</i> ).
1911. Portsmouth	Prof. D'Arcy W. Thompson, C.B.	Dr. J. H. Ashworth, C. Foran, R. D. Laurie, Dr. H. W. M. Tims ( <i>Rec.</i> ).
1912. Dundee ...	Dr. P. Chalmers Mitchell, F.R.S.	Dr. J. H. Ashworth, R. D. Laurie, Miss D. L. Mackinnon, Dr. H. W. M. Tims ( <i>Rec.</i> ).
1913. Birmingham	Dr. H. F. Gadow, F.R.S.....	Dr. J. H. Ashworth, Dr. C. L. Boulenger, R. D. Laurie, Dr. H. W. M. Tims ( <i>Rec.</i> ).
1914. Australia ...	Prof. A. Dendy, F.R.S.....	Dr. J. H. Ashworth, Dr. T. S. Hall, Prof. W. A. Haswell, R. D. Laurie, Prof. H. W. Marett Tims ( <i>Rec.</i> ).
1915. Manchester	Prof. E. A. Minchin, F.R.S.	Dr. J. H. Ashworth ( <i>Rec.</i> ), F. Balfour Browne, R. D. Laurie, Dr. J. Stuart Thomson.

SECTION E.<sup>5</sup>—GEOGRAPHY.

1901. Glasgow ...	Dr. H. R. Mill, F.R.G.S. ....	H. N. Dickson ( <i>Rec.</i> ), E. Heawood, G. Sandeman, A. C. Turner.
1902. Belfast.....	Sir T. H. Holdich, K.C.B. ...	G. G. Chisholm ( <i>Rec.</i> ), E. Heawood, Dr. A. J. Herbertson, Dr. J. A. Lindsay.
1903. Southport...	Capt. E. W. Creak, R.N., C.B., F.R.S.	E. Heawood ( <i>Rec.</i> ), Dr. A. J. Herbertson, E. A. Reeves, Capt. J. C. Underwood.
1904. Cambridge	Douglas W. Freshfield.....	E. Heawood ( <i>Rec.</i> ), Dr. A. J. Herbertson, H. Y. Oldham, E. A. Reeves.
1905. SouthAfrica	Adm. Sir W. J. L. Wharton, R.N., K.C.B., F.R.S.	A. H. Cornish-Bowden, F. Flowers, Dr. A. J. Herbertson ( <i>Rec.</i> ), H. Y. Oldham.
1906. York. ....	Rt. Hon. Sir George Goldie, K.C.M.G., F.R.S.	E. Heawood ( <i>Rec.</i> ), Dr. A. J. Herbertson, E. A. Reeves, G. Yeld.
1907. Leicester ...	George G. Chisholm, M.A. ...	E. Heawood ( <i>Rec.</i> ), O. J. R. Howarth, E. A. Reeves, T. Walker.
1908. Dublin .....	Major E. H. Hills, C.M.G., R.E.	W. F. Bailey, W. J. Barton, O. J. P. Howarth ( <i>Rec.</i> ), E. A. Reeves.
1909. Winnipeg...	Col. Sir D. Johnston, K.C.M.G., C.B., R.E.	G. G. Chisholm ( <i>Rec.</i> ), J. McFarlane, A. McIntyre.
1910. Sheffield ...	Prof. A. J. Herbertson, M.A., Ph.D.	Rev. W. J. Barton ( <i>Rec.</i> ), Dr. R. Brown, J. McFarlane, E. A. Reeves.
1911. Portsmouth	Col. C. F. Close, R.E., C.M.G.	J. McFarlane ( <i>Rec.</i> ), E. A. Reeves, W. P. Smith.
1912. Dundee ...	Col. Sir C. M. Watson, K.C.M.G.	Rev. W. J. Barton ( <i>Rec.</i> ), J. McFarlane, E. A. Reeves, D. Wylie.

<sup>5</sup> Section E was that of 'Anatomy and Medicine,' 1835-1840; of 'Physiology' (afterwards incorporated in Section D), 1841-1847. It was assigned to 'Geography and Ethnology,' 1851-1868; 'Geography,' 1869.

Date and Place	Presidents	Secretaries ( <i>Rec.</i> = Recorder)
1913. Birmingham	Prof. H. N. Dickson, D.Sc.	Rev. W. J. Barton ( <i>Rec.</i> ), P. E. Martineau, J. McFarlane, E. A. Reeves.
1914. Australia ...	Sir C. P. Lucas, K.C.B., K.C.M.G.	J. A. Leach, J. McFarlane, H. Yule Oldham ( <i>Rec.</i> ), F. Poate.
1915. Manchester	Major H. G. Lyons, F.R.S....	Dr. R. N. Rudmose Browne, J. McFarlane ( <i>Rec.</i> ).

SECTION F.<sup>6</sup>—ECONOMIC SCIENCE AND STATISTICS.

1901. Glasgow ...	Sir R. Giffen, K.C.B., F.R.S.	W. W. Blackie, A. L. Bowley, E. Cannan ( <i>Rec.</i> ), S. J. Chapman.
1902. Belfast ...	E. Cannan, M.A., LL.D. ....	A. L. Bowley ( <i>Rec.</i> ), Prof. S. J. Chapman, Dr. A. Duffin.
1903. Southport	E. W. Brabrook, C.B. ....	A. L. Bowley ( <i>Rec.</i> ), Prof. S. J. Chapman, Dr. B. W. Ginsburg, G. Lloyd.
1904. Cambridge	Prof. Wm. Smart, LL.D. ....	J. E. Bidwell, A. L. Bowley ( <i>Rec.</i> ), Prof. S. J. Chapman, Dr. B. W. Ginsburg.
1905. SouthAfrica	Rev. W. Cunningham, D.D., D.Sc.	R. à Ababelton, A. L. Bowley ( <i>Rec.</i> ), Prof. H. E. S. Fremantle, H. O. Meredith.
1906. York.....	A. L. Bowley, M.A. ....	Prof. S. J. Chapman ( <i>Rec.</i> ), D. H. Macgregor, H. O. Meredith, B. S. Rowntree.
1907. Leicester ...	Prof. W. J. Ashley, M.A.....	Prof. S. J. Chapman ( <i>Rec.</i> ), D. H. Macgregor, H. O. Meredith, T. S. Taylor.
1908. Dublin.....	W. M. Acworth, M.A. ....	W. G. S. Adams, Prof. S. J. Chapman ( <i>Rec.</i> ), Prof. D. H. Macgregor, H. O. Meredith.
	<i>Sub-section of Agriculture—</i> Rt. Hon. Sir H. Plunkett.	A. D. Hall, Prof. J. Percival, J. H. Priestley, Prof. J. Wilson.
1909. Winnipeg...	Prof. S. J. Chapman, M.A. ...	Prof. A. B. Clark, Dr. W. A. Manahan, Dr. W. R. Scott ( <i>Rec.</i> ).
1910. Sheffield ...	Sir H. Llewellyn Smith, K.C.B., M.A.	C. R. Fay, H. O. Meredith ( <i>Rec.</i> ), Dr. W. R. Scott, R. Wilson.
1911. Portsmouth	Hon. W. Pember Reeves .....	C. R. Fay, Dr. W. R. Scott ( <i>Rec.</i> ), H. A. Stibbs.
1912. Dundee ...	Sir H. H. Cunynghame, K.C.B.	C. R. Fay, Dr. W. R. Scott ( <i>Rec.</i> ), E. Tosh.
1913. Birmingham	Rev. P. H. Wicksteed, M.A.	C. R. Fay, Prof. A. W. Kirkaldy, Prof. H. O. Meredith, Dr. W. R. Scott ( <i>Rec.</i> ).
1914. Australia ...	Prof. E. C. K. Gonner .....	Prof. R. F. Irvine, Prof. A. W. Kirkaldy ( <i>Rec.</i> ), G. H. Knibbs, Prof. H. O. Meredith.
1915. Manchester	Prof. W. R. Scott .....	B. Ellinger, E. J. W. Jackson, Prof. A. W. Kirkaldy ( <i>Rec.</i> ).

SECTION G.<sup>7</sup>—ENGINEERING.

1901. Glasgow ...	R. E. Crompton, M.Inst.C.E.	H. Bamford, W. E. Dalby, W. A. Price ( <i>Rec.</i> ).
1902. Belfast ...	Prof. J. Perry, F.R.S. ....	M. Barr, W. A. Price ( <i>Rec.</i> ), J. Wylie.
1903. Southport	C. Hawksley, M.Inst.C.E. ...	Prof. W. E. Dalby, W. T. Maccall, W. A. Price ( <i>Rec.</i> ).

<sup>6</sup> 'Statistics,' 1835-1855.<sup>7</sup> 'Mechanical Science,' 1836-1900.



Date and Place	Presidents	Secretaries ( <i>Rec.</i> = Recorder)
1904. Cambridge	Hon. C. A. Parsons, F.R.S. ...	J. B. Peace, W. T. Maccall, W. A. Price ( <i>Rec.</i> ).
1905. SouthAfrica	Col. Sir C. Scott-Moncrieff, G.C.S.I., K.C.M.G., R.E.	W. T. Maccall, W. B. Marshall ( <i>Rec.</i> ), Prof. H. Payne, E. Williams.
1906. York.....	J. A. Ewing, F.R.S. ....	W. T. Maccall, W. A. Price ( <i>Rec.</i> ), J. Triffit.
1907. Leicester ...	Prof. Silvanus P. Thompson, F.R.S.	Prof. E. G. Coker, A. C. Harris, W. A. Price ( <i>Rec.</i> ), H. E. Wimperis.
1908. Dublin .....	Dugald Clerk, F.R.S. ....	Prof. E. G. Coker, Dr. W. E. Lilly, W. A. Price ( <i>Rec.</i> ), H. E. Wimperis.
1909. Winnipeg...	Sir W. H. White, K.C.B., F.R.S.	E. E. Brydone-Jack, Prof. E. G. Coker, Prof. E. W. Marchant, W. A. Price ( <i>Rec.</i> ).
1910. Sheffield ..	Prof. W. E. Dalby, M.A., M.Inst.C.E.	F. Boulden, Prof. E. G. Coker ( <i>Rec.</i> ), A. A. Rowse, H. E. Wimperis.
1911. Portsmouth	Prof. J. H. Biles, LL.D., D.Sc.	H. Ashley, Prof. E. G. Coker ( <i>Rec.</i> ), A. A. Rowse, H. E. Wimperis.
1912. Dundee ...	Prof. A. Barr, D.Sc.....	Prof. E. G. Coker ( <i>Rec.</i> ), A. R. Fulton, H. Richardson, A. A. Rowse, H. E. Wimperis.
1913. Birmingham	Prof. Gisbert Kapp, D.Eng....	Prof. E. G. Coker ( <i>Rec.</i> ), J. Purser, A. A. Rowse, H. E. Wimperis.
1914. Australia ...	Prof. E. G. Coker, D.Sc.....	Prof. G. W. O. Howe ( <i>Rec.</i> ), Prof. H. Payne, Prof. W. M. Thornton, Prof. W. H. Warren.
1915. Manchester	Dr. H. S. Hele-Shaw, F.R.S.	Dr. W. Cramp, J. Frith, Prof. G. W. O. Howe ( <i>Rec.</i> ).

SECTION H.<sup>8</sup>—ANTHROPOLOGY.

1901. Glasgow ...	Prof. D. J. Cunningham, F.R.S.	W. Crooke, Prof. A. F. Dixon, J. F. Gemmill, J. L. Myres ( <i>Rec.</i> ).
1902. Belfast ...	Dr. A. C. Haddon, F.R.S. ...	R. Campbell, Prof. A. F. Dixon, J. L. Myres ( <i>Rec.</i> ).
1903. Southport...	Prof. J. Symington, F.R.S. ...	E. N. Fallaize, H. S. Kingsford, E. M. Littler, J. L. Myres ( <i>Rec.</i> ).
1904. Cambridge	H. Balfour, M.A. ....	W. L. H. Duckworth, E. N. Fallaize, H. S. Kingsford, J. L. Myres ( <i>Rec.</i> ).
1905. SouthAfrica	Dr. A. C. Haddon, F.R.S. ...	A. R. Brown, A. von Dessauer, E. S. Hartland ( <i>Rec.</i> ).
1906. York.....	E. Sidney Hartland, F.S.A....	Dr. G. A. Auden, E. N. Fallaize ( <i>Rec.</i> ), H. S. Kingsford, Dr. F. C. Shrub-sall.
1907. Leicester ..	D. G. Hogarth, M.A.....	C. J. Billson, E. N. Fallaize ( <i>Rec.</i> ), H. S. Kingsford, Dr. F. C. Shrub-sall.
1908. Dublin .....	Prof. W. Ridgeway, M.A. ...	E. N. Fallaize ( <i>Rec.</i> ), H. S. Kingsford, Dr. F. C. Shrub-sall, L. E. Steele.
1909. Winnipeg...	Prof. J. L. Myres, M.A. ....	H. S. Kingsford ( <i>Rec.</i> ), Prof. C. J. Patten, Dr. F. C. Shrub-sall.
1910. Sheffield ...	W. Crooke, B.A. ....	E. N. Fallaize ( <i>Rec.</i> ), H. S. Kingsford, Prof. C. J. Patten, Dr. F. C. Shrub-sall.

Date and Place	Presidents	Secretaries ( <i>Rec.</i> = Recorder)
1911. Portsmouth	W. H. R. Rivers, M.D., F.R.S.	E. N. Fallaize ( <i>Rec.</i> ), H. S. Kingsford, E. W. Martindell, H. Rundle, Dr. F. C. Shruballs.
1912. Dundee ...	Prof. G. Elliot Smith, F.R.S.	D. D. Craig, E. N. Fallaize ( <i>Rec.</i> ), E. W. Martindell, Dr. F. C. Shruballs.
1913. Birmingham	Sir Richard Temple, Bart. ...	E. N. Fallaize ( <i>Rec.</i> ), E. W. Martindell, Dr. F. C. Shruballs, T. Yeates.
1914. Australia ...	Sir E. F. im Thurn, C.B., K.C.M.G.	Prof. R. J. A. Berry, Dr. B. Malinowski, Dr. R. R. Marett ( <i>Rec.</i> ), Prof. J. T. Wilson.
1915. Manchester	Prof. C. G. Seligman.....	E. N. Fallaize ( <i>Rec.</i> ), Dr. F. C. Shruballs, J. S. B. Stopford.

SECTION I.<sup>9</sup>—PHYSIOLOGY (including EXPERIMENTAL  
PATHOLOGY AND EXPERIMENTAL PSYCHOLOGY).

1901. Glasgow ...	Prof. J. G. McKendrick, F.R.S.	W. B. Brodie, W. A. Osborne, Prof. W. H. Thompson ( <i>Rec.</i> ).
1902. Belfast ...	Prof. W. D. Halliburton, F.R.S.	J. Barcroft, Dr. W. A. Osborne ( <i>Rec.</i> ), Dr. C. Shaw.
1904. Cambridge	Prof. C. S. Sherrington, F.R.S.	J. Barcroft ( <i>Rec.</i> ), Prof. T. G. Brodie, Dr. L. E. Shore.
1905. South Africa	Col. D. Bruce, C.B., F.R.S. ...	J. Barcroft ( <i>Rec.</i> ), Dr. Baumann, Dr. Mackenzie, Dr. G. W. Robertson, Dr. Stanwell.
1906. York.....	Prof. F. Gotch, F.R.S. ....	J. Barcroft ( <i>Rec.</i> ), Dr. J. M. Hamill, Prof. J. S. Macdonald, Dr. D. S. Long.
1907. Leicester ...	Dr. A. D. Waller, F.R.S. ....	Dr. N. H. Alcock, J. Barcroft ( <i>Rec.</i> ), Prof. J. S. Macdonald, Dr. A. Warner.
1908. Dublin .....	Dr. J. Scott Haldane, F.R.S.	Prof. D. J. Coffey, Dr. P. T. Herring, Prof. J. S. Macdonald, Dr. H. E. Roaf ( <i>Rec.</i> ).
1909. Winnipeg...	Prof. E. H. Starling, F.R.S....	Dr. N. H. Alcock ( <i>Rec.</i> ), Prof. P. T. Herring, Dr. W. Webster.
1910. Sheffield ...	Prof. A. B. Macallum, F.R.S.	Dr. H. G. M. Henry, Keith Lucas, Dr. H. E. Roaf ( <i>Rec.</i> ), Dr. J. Tait.
1911. Portsmouth	Prof. J. S. Macdonald, B.A.	Dr. J. T. Leon, Dr. Keith Lucas, Dr. H. E. Roaf ( <i>Rec.</i> ), Dr. J. Tait.
1912. Dundee ...	Leonard Hill, F.R.S. ....	Dr. Keith Lucas, W. Moodie, Dr. H. E. Roaf ( <i>Rec.</i> ), Dr. J. Tait.
1913. Birmingham	Dr. F. Gowland Hopkins, F.R.S.	C. L. Burt, Prof. P. T. Herring, Dr. T. G. Maitland, Dr. H. E. Roaf ( <i>Rec.</i> ), Dr. J. Tait.
1914. Australia...	Prof. B. Moore, F.R.S. ....	Prof. P. T. Herring ( <i>Rec.</i> ), Prof. T. H. Milroy, Prof. W. A. Osborne, Prof. Sir T. P. Anderson Stuart.
1915. Manchester	Prof. W. M. Bayliss, F.R.S.	C. L. Burt, Prof. P. T. Herring ( <i>Rec.</i> ), Dr. F. W. Lamb, Dr. J. Tait.

Date and Place	Presidents	Secretaries ( <i>Rec.</i> = Recorder)
SECTION K. <sup>10</sup> —BOTANY.		
1901. Glasgow ...	Prof. I. B. Balfour, F.R.S. ...	D. T. Gwynne-Vaughan, G. F. Scott-Elliot, A. C. Seward ( <i>Rec.</i> ), H. Wager.
1902. Belfast ...	Prof. J. R. Green, F.R.S. ....	A. G. Tansley, Rev. C. H. Waddell, H. Wager ( <i>Rec.</i> ), R. H. Yapp.
1903. Southport	A. C. Seward, F.R.S. ....	H. Ball, A. G. Tansley, H. Wager ( <i>Rec.</i> ), R. H. Yapp.
1904. Cambridge	Francis Darwin, F.R.S. .... <i>Sub-section of Agriculture</i> — Dr. W. Somerville.	Dr. F. F. Blackman, A. G. Tansley, H. Wager ( <i>Rec.</i> ), T. B. Wood, R. H. Yapp.
1905. SouthAfrica	Harold Wager, F.R.S. ....	R. P. Gregory, Dr. Marloth, Prof. Pearson, Prof. R. H. Yapp ( <i>Rec.</i> ).
1906. York.....	Prof. F. W. Oliver, F.R.S. ...	Dr. A. Burtt, R. P. Gregory, Prof. A. G. Tansley ( <i>Rec.</i> ), Prof. R. H. Yapp.
1907. Leicester ...	Prof. J. B. Farmer, F.R.S. ...	W. Bell, R. P. Gregory, Prof. A. G. Tansley ( <i>Rec.</i> ), Prof. R. H. Yapp.
1908. Dublin .....	Dr. F. F. Blackman, F.R.S....	Prof. H. H. Dixon, R. P. Gregory, A. G. Tansley ( <i>Rec.</i> ), Prof. R. H. Yapp.
1909. Winnipeg...	Lieut.-Col. D. Prain, C.I.E., F.R.S.  <i>Sub-section of Agriculture</i> — Major P. G. Craigie, C.B.	Prof. A. H. R. Buller, Prof. D. T. Gwynne-Vaughan, Prof. R. H. Yapp ( <i>Rec.</i> ).
1910. Sheffield ...	Prof. J. W. H. Trail, F.R.S.	W. J. Black, Dr. E. J. Russell, Prof. J. Wilson.
1911. Portsmouth	Prof. F. E. Weiss, D.Sc. ....	B. H. Bentley, R. P. Gregory, Prof. D. T. Gwynne-Vaughan, Prof. R. H. Yapp ( <i>Rec.</i> ).
1912. Dundee ...	Prof. F. Keeble, D.Sc. ....	C. G. Delahunt, Prof. D. T. Gwynne-Vaughan, Dr. C. E. Moss, Prof. R. H. Yapp ( <i>Rec.</i> ).
1913. Birmingham	Miss Ethel Sargant, F.L.S....	J. Golding, H. R. Pink, Dr. E. J. Russell.
1914. Australia ...	Prof. F. O. Bower, F.R.S. ...	J. Brebner, Prof. D. T. Gwynne-Vaughan ( <i>Rec.</i> ), Dr. C. E. Moss, D. Thoday.
1915. Manchester	Prof. W. H. Lang, F.R.S. ...	W. B. Grove, Prof. D. T. Gwynne-Vaughan ( <i>Rec.</i> ), Dr. C. E. Moss, D. Thoday.
Prof. A. J. Ewart, Prof. T. Johnson ( <i>Rec.</i> ), Prof. A. A. Lawson, Miss E. N. Thomas.	Prof. W. H. Lang, F.R.S. ...	R. S. Adamson, Dr. C. E. Moss ( <i>Rec.</i> ), D. Thoday.

SECTION L.—EDUCATIONAL SCIENCE.

1901. Glasgow ...	Sir John E. Gorst, F.R.S. ...	R. A. Gregory, W. M. Heller, R. Y. Howie, C. W. Kimmins, Prof. H. L. Withers ( <i>Rec.</i> ).
1902. Belfast ...	Prof. H. E. Armstrong, F.R.S.	Prof. R. A. Gregory, W. M. Heller ( <i>Rec.</i> ), R. M. Jones, Dr. C. W. Kimmins, Prof. H. L. Withers.
1903. Southport ..	Sir W. de W. Abney, K.C.B., F.R.S.	Prof. R. A. Gregory, W. M. Heller ( <i>Rec.</i> ), Dr. C. W. Kimmins, Dr. H. L. Snape.

<sup>10</sup> Established 1895.

Date and Place	Presidents	Secretaries ( <i>Rec.</i> = Recorder)
1904. Cambridge	Bishop of Hereford, D.D. ...	J. H. Flather, Prof. R. A. Gregory, W. M. Heller ( <i>Rec.</i> ), Dr. C. W. Kimmins.
1905. SouthAfrica	Prof. Sir R. C. Jebb, D.C.L., M.P.	A. D. Hall, Prof. Hele-Shaw, Dr. C. W. Kimmins ( <i>Rec.</i> ), J. R. Whitton.
1906. York.....	Prof. M. E. Sadler, LL.D. ...	Prof. R. A. Gregory, W. M. Heller ( <i>Rec.</i> ), Hugh Richardson.
1907. Leicester ...	Sir Philip Magnus, M.P. ....	W. D. Eggar, Prof. R. A. Gregory ( <i>Rec.</i> ), J. S. Laver, Hugh Richardson.
1908. Dublin .....	Prof. L. C. Miall, F.R.S. ....	Prof. E. P. Culverwell, W. D. Eggar, George Fletcher, Prof. R. A. Gregory ( <i>Rec.</i> ), Hugh Richardson.
1909. Winnipeg...	Rev. H. B. Gray, D.D. ....	W. D. Eggar, R. Fletcher, J. L. Holland ( <i>Rec.</i> ), Hugh Richardson.
1910. Sheffield ...	Principal H. A. Miers, F.R.S.	A. J. Arnold, W. D. Eggar, J. L. Holland ( <i>Rec.</i> ), Hugh Richardson.
1911. Portsmouth	Rt. Rev. J. E. C. Weldon, D.D.	W. D. Eggar, O. Freeman, J. L. Holland ( <i>Rec.</i> ), Hugh Richardson.
1912. Dundee ...	Prof. J. Adams, M.A. ....	D. Berridge, Dr. J. Davidson, Prof. J. A. Green ( <i>Rec.</i> ), Hugh Richardson.
1913. Birmingham	Principal E. H. Griffiths, F.R.S.	D. Berridge, Rev. S. Blofeld, Prof. J. A. Green ( <i>Rec.</i> ), H. Richardson.
1914. Australia ...	Prof. J. Perry, F.R.S. ....	P. Board, C. A. Buckmaster, Prof. J. A. Green ( <i>Rec.</i> ), J. Smyth.
1915. Manchester	Mrs. Henry Sidgwick .....	D. Berridge, F. A. Brüssel, Prof. J. A. Green ( <i>Rec.</i> ), H. Richardson.

SECTION M.—AGRICULTURE.

1912. Dundee ...	T. H. Middleton, M.A.....	Dr. C. Crowther, J. Golding, Dr. A. Lauder, Dr. E. J. Russell ( <i>Rec.</i> ).
1913. Birmingham	Prof. T. B. Wood, M.A. ....	W. E. Collinge, Dr. C. Crowther, J. Golding, Dr. E. J. Russell ( <i>Rec.</i> ).
1914. Australia ...	A. D. Hall, F.R.S.....	Prof. T. Cherry, J. Golding ( <i>Rec.</i> ), Dr. A. Lauder, Prof. R. D. Watt.
1915. Manchester	R. H. Rew, C.B. ....	Prof. C. Crowther ( <i>Rec.</i> ), Dr. A. Lauder, T. J. Young.

EVENING DISCOURSES, 1901-15.

(For 1916, see *General Meetings*, p. xli.)

Date and Place	Lecturer	Subject of Discourse
1901. Glasgow ...	Prof. W. Ramsay, F.R.S. ....	The Inert Constituents of the Atmosphere.
1902. Belfast ...	Francis Darwin, F.R.S. ....	The Movements of Plants.
	Prof. J. J. Thomson, F.R.S....	Becquerel Rays and Radio-activity.
1903. Southport...	Prof. W. F. R. Weldon, F.R.S.	Inheritance.
	Dr. R. Munro .....	Man as Artist and Sportsman in the Palæolithic Period.
1904. Cambridge	Dr. A. Rowe .....	The Old Chalk Sea, and some of its Teachings.
	Prof. G. H. Darwin, F.R.S....	Ripple-Marks and Sand-Dunes.
	Prof. H. F. Osborn .....	Palæontological Discoveries in the Rocky Mountains.

Date and Place	Lecturer	Subject of Discourse
1905. S. Africa: Cape Town ...	Prof. E. B. Poulton, F.R.S. ...	W. J. Burchell's Discoveries in South Africa.
	C. Vernon Boys, F.R.S. ....	Some Surface Actions of Fluids.
Durban ...	Douglas W. Freshfield.....	The Mountains of the Old World.
	Prof. W. A. Herdman, F.R.S.	Marine Biology.
Pietermaritzburg.	Col. D. Bruce, C.B., F.R.S....	Sleeping Sickness.
Johannesburg	H. T. Ferrar .....	The Cruise of the 'Discovery.'
	Prof. W. E. Ayrton, F.R.S. ...	The Distribution of Power.
Pretoria ...	Prof. J. O. Arnold.....	Steel as an Igneous Rock.
	A. E. Shipley, F.R.S. ....	Fly-borne Diseases: Malaria, Sleeping Sickness, &c.
Bloemfontein...	A. R. Hinks .....	The Milky Way and the Clouds of Magellan.
Kimberley ...	Sir Wm. Crookes, F.R.S. ....	Diamonds.
	Prof. J. B. Porter .....	The Bearing of Engineering on Mining.
Bulawayo ...	D. Randall-MacIver .....	The Ruins of Rhodesia.
1906. York.....	Dr. Tempest Anderson.....	Volcanoes.
	Dr. A. D. Waller, F.R.S. ....	The Electrical Signs of Life, and their Abolition by Chloroform.
1907. Leicester ...	W. Duddell, F.R.S. ....	The Ark and the Spark in Radiotelegraphy.
	Dr. F. A. Dixey.....	Recent Developments in the Theory of Mimicry.
1908. Dublin .....	Prof. H. H. Turner, F.R.S. ...	Halley's Comet.
	Prof. W. M. Davis .....	The Lessons of the Colorado Canyon.
1909. Winnipeg..	Dr. A. E. H. Tutton, F.R.S....	The Seven Styles of Crystal Architecture.
	Prof. W. A. Herdman, F.R.S.	Our Food from the Waters.
	<sup>1</sup> Prof. H. B. Dixon, F.R.S. ...	The Chemistry of Flame.
	<sup>1</sup> Prof. J. H. Poynting, F.R.S.	The Pressure of Light.
-1910. Sheffield ...	Prof. W. Stirling, M.D. ....	Types of Animal Movement. <sup>2</sup>
	D. G. Hogarth .....	New Discoveries about the Hittites.
1911. Portsmouth	Dr. Leonard Hill, F.R.S. ....	The Physiology of Submarine Work.
	Prof. A. C. Seward, F.R.S. ...	Links with the Past in the Plant World.
1912. Dundee ...	Prof. W. H. Bragg, F.R.S. ...	Radiations, Old and New
	Prof. A. Keith, M.D.....	The Antiquity of Man.
1913. Birmingham	Sir H. H. Cunynghame, K.O.B.	Explosions in Mines and the Means of Preventing Them.
	Dr. A. Smith Woodward, F.R.S.	Missing Links among Extinct Animals.
1914. Australia: Adelaide	Sir Oliver J. Lodge, F.R.S....	The Ether of Space.
	Prof. W. J. Sollas, F.R.S. ...	Ancient Hunters.
Melbourne	Prof. E. B. Poulton, F.R.S. ...	Mimicry.
	Dr. F. W. Dyson, F.R.S. ...	Greenwich Observatory.
Sydney ...	Prof. G. Elliot Smith, F.R.S.	Primitive Man.
	Sir E. Rutherford, F.R.S. ...	Atoms and Electrons.
Brisbane	Prof. H. E. Armstrong, F.R.S.	The Materials of Life.
	Prof. G. W. O. Howe .....	Wireless Telegraphy.
	Sir E. A. Schäfer, F.R.S.....	Australia and the British Association.
1915. Manchester	H. W. T. Wager, F.R.S. ....	The Behaviour of Plants in Response to Light.
	Prof. R. A. Sampson, F.R.S.	A Census of the Skies.

<sup>1</sup> 'Popular Lectures,' delivered to the citizens of Winnipeg.<sup>2</sup> Repeated, to the public, on Wednesday, September 7.

## LECTURES TO THE OPERATIVE CLASSES, 1901-11.

Date and Place	Lecturer	Subject of Lecture
1901. Glasgow ...	H. J. Mackinder, M.A.....	The Movements of Men by Land and Sea.
1902. Belfast.....	Prof. L. C. Miall, F.R.S. ....	Gnats and Mosquitoes.
1903. Southport...	Dr. J. S. Flett .....	Martinique and St. Vincent: the Eruptions of 1902.
1904. Cambridge.	Dr. J. E. Marr, F.R.S. ....	The Forms of Mountains.
1906. York.....	Prof. S. P. Thompson, F.R.S.	The Manufacture of Light.
1907. Leicester ...	Prof. H. A. Miers, F.R.S.....	The Growth of a Crystal.
1908. Dublin .....	Dr. A. E. H. Tutton, F.R.S.	The Crystallisation of Water.
1910. Sheffield ...	C. T. Heycock, F.R.S. ....	Metallic Alloys.
1911. Portsmouth	Dr. H. R. Mill .....	Rain.

## PUBLIC OR CITIZENS' LECTURES, 1912-15.

(For 1916, see p. lxi.)

Date and Place	Lecturer	Subject of Lecture
1912. Dundee ...	Prof. B. Moore, D.Sc. ....	Science and National Health.
	Prof. E. C. K. Gonner, M.A.	Prices and Wages.
	Prof. A. Fowler, F.R.S. ....	The Sun.
1913. Birmingham	Dr. A. C. Haddon, F.R.S. ...	The Decorative Art of Savages.
	Dr. Vaughan Cornish .....	The Panama Canal.
	Leonard Doncaster, M.A. ...	Recent Work on Heredity and its Application to Man.
	Dr. W. Rosenhain, F.R.S. ...	Metals under the Microscope.
	Frederick Soddy, F.R.S. ....	The Evolution of Matter.
1914. Australia: Perth ...	Prof. W. A. Herdman, F.R.S.	Why we Investigate the Ocean.
	Prof. A. S. Eddington, F.R.S.	Stars and their Movements.
	H. Balfour, M.A. ....	Primitive Methods of Making Fire.
	Prof. A. D. Waller, F.R.S. ...	Electrical Action of the Human Heart.
Kalgoorlie	C. A. Buckmaster, M.A. ....	Mining Education in England.
Adelaide	Prof. E. C. K. Gonner, M.A.	Saving and Spending.
Melbourne	Dr. W. Rosenhain, F.R.S. ...	Making of a Big Gun.
	Prof. H. B. Dixon, F.R.S. ...	Explosions.
Sydney ...	Prof. B. Moore, F.R.S.....	Brown Earth and Bright Sunshine.
	Prof. H. H. Turner, P.R.S. ...	Comets.
Brisbane	Dr. A. C. Haddon, F.R.S. ...	Decorative Art in Papua.
1915. Manchester and Neighbourhood	Prof. F. W. Gamble, F.R.S.	Evolution and War.
	Dr. Vaughan Cornish .....	Strategic Geography of the War.
	Dr. W. Rosenhain, F.R.S. ...	Making of a Big Gun.
	Prof. W. Stirling .....	Curiosities and Defects of Sight.
	A. R. Hinks, F.R.S. ....	Daily Uses of Astronomy.
	Prof. B. Moore, F.R.S.....	Health Conditions in the Modern Workshop.
	Rev. A. L. Cortie .....	Formation of the Sun and Stars.
	Prof. H. H. Turner, F.R.S. ...	Some Lessons from Astronomy.

CHAIRMEN AND SECRETARIES OF THE CONFERENCES OF DELEGATES OF CORRESPONDING SOCIETIES, 1901-15.<sup>1</sup>

(For 1916, see p. xliii.)

Date and Place	Chairmen	Secretaries
1901. Glasgow ...	F. W. Rudler, F.G.S. ....	Dr. J. G. Garson, A. Somerville
1902. Belfast.....	Prof. W. W. Watts, F.G.S. ...	E. J. Bles.
1903. Southport..	W. Whitaker, F.R.S. ....	F. W. Rudler.
1904. Cambridge	Prof. E. H. Griffiths, F.R.S.	F. W. Rudler.
1905. London ...	Dr. A. Smith Woodward, F.R.S.	F. W. Rudler.
1906. York.....	Sir Edward Brabrook, C.B....	F. W. Rudler.
1907. Leicester ...	H. J. Mackinder, M.A.....	F. W. Rudler, I.S.O.
1908. Dublin .....	Prof. H. A. Miers, F.R.S.....	W. P. D. Stebbing.
1909. London ...	Dr. A. C. Haddon, F.R.S. ...	W. P. D. Stebbing.
1910. Sheffield ...	Dr. Tempest Anderson.....	W. P. D. Stebbing.
1911. Portsmouth	Prof. J. W. Gregory, F.R.S....	W. P. D. Stebbing.
1912. Dundee ...	Prof. F. O. Bower, F.R.S. ...	W. P. D. Stebbing.
1913. Birmingham	Dr. P. Chalmers Mitchell, F.R.S.	W. P. D. Stebbing.
1914. Le Havre...	Sir H. George Fordham ...	W. Mark Webb.
1915. Manchester	Sir T. H. Holland, F.R.S. ...	W. Mark Webb.

<sup>1</sup> Established 1885.

*General Statement of Sums which have been paid on account of  
Grants for Scientific Purposes, 1901-1915.*

1901.	£	s.	d.		£	s.	d.
Electrical Standards .....	45	0	0	Wave-length Tables .....	5	0	0
Seismological Observations...	75	0	0	Life-zones in British Car- boniferous Rocks .....	10	0	0
Wave-length Tables.....	4	14	0	Exploration of Irish Caves ...	45	0	0
Isomorphous Sulphonic Der- ivatives of Benzene .....	35	0	0	Table at the Zoological Station, Naples .....	100	0	0
Life-zones in British Car- boniferous Rocks .....	20	0	0	Index Generum et Specierum Animalium .....	100	0	0
Underground Water of North- west Yorkshire .....	50	0	0	Migration of Birds .....	15	0	0
Exploration of Irish Caves...	15	0	0	Structure of Coral Reefs of Indian Ocean.....	50	0	0
Table at the Zoological Sta- tion, Naples .....	100	0	0	Compound Ascidiæ of the Clyde Area .....	25	0	0
Table at the Biological La- boratory, Plymouth .....	20	0	0	Terrestrial Surface Waves ...	15	0	0
Index Generum et Specierum Animalium.....	75	0	0	Legislation regulating Wo- men's Labour .....	30	0	0
Migration of Birds .....	10	0	0	Small Screw Gauge .....	20	0	0
Terrestrial Surface Waves ...	5	0	0	Resistance of Road Vehicles to Traction.....	50	0	0
Changes of Land-level in the Phlegræan Fields.....	50	0	0	Ethnological Survey of Canada .....	15	0	0
Legislation regulating Wo- men's Labour.....	15	0	0	Age of Stone Circles.....	30	0	0
Small Screw Gauge .....	45	0	0	Exploration in Crete.....	100	0	0
Resistance of Road Vehicles to Traction.....	75	0	0	Anthropometric Investigation of Native Egyptian Soldiers	15	0	0
Silchester Excavation .....	10	0	0	Excavations on the Roman Site at Gelligaer .....	5	0	0
Ethnological Survey of Canada .....	30	0	0	Changes in Hæmoglobin .....	15	0	0
Anthropological Teaching ...	5	0	0	Work of Mammalian Heart under Influence of Drugs...	20	0	0
Exploration in Crete .....	145	0	0	Investigation of the Cyano- phyceæ .....	10	0	0
Physiological Effects of Pep- tone.....	30	0	0	Reciprocal Influence of Uni- versities and Schools .....	5	0	0
Chemistry of Bone Marrow...	5	15	11	Conditions of Health essen- tial to carrying on Work in Schools .....	2	0	0
Suprarenal Capsules in the Rabbit.....	5	0	0	Corresponding Societies Com- mittee .....	15	0	0
Fertilisation in Phæophyceæ	15	0	0		<u>£947</u>	<u>0</u>	<u>0</u>
Morphology, Ecology, and Taxonomy of Podoste- maceæ.....	20	0	0				
Corresponding Societies Com- mittee.....	15	0	0				
	<u>£920</u>	<u>9</u>	<u>11</u>				

## 1902.

Electrical Standards.....	40	0	0
Seismological Observations...	35	0	0
Investigation of the Upper Atmosphere by means of Kites .....	75	0	0
Magnetic Observations at Fal- mouth .....	80	0	0
Relation between Absorption Spectra and Organic Sub- stances .....	20	0	0

## 1903.

Electrical Standards.....	35	0	0
Seismological Observations...	40	0	0
Investigation of the Upper Atmosphere by means of Kites .....	75	0	0
Magnetic Observations at Fal- mouth .....	40	0	0
Study of Hydro-aromatic Sub- stances .....	20	0	0
Erratic Blocks .....	10	0	0
Exploration of Irish Caves ...	40	0	0
Underground Waters of North- west Yorkshire .....	40	0	0



	£	s.	d.
Life-zones in British Carboniferous Rocks .....	5	0	0
Geological Photographs .....	10	0	0
Table at the Zoological Station at Naples .....	100	0	0
Index Generum et Specierum Animalium .....	100	0	0
Tidal Bore, Sea Waves, and Beaches .....	15	0	0
Scottish National Antarctic Expedition .....	50	0	0
Legislation affecting Women's Labour .....	25	0	0
Researches in Crete .....	100	0	0
Age of Stone Circles.....	3	13	2
Anthropometric Investigation	5	0	0
Anthropometry of the Todas and other Tribes of Southern India .....	50	0	0
The State of Solution of Proteids.....	20	0	0
Investigation of the Cyanophyceæ .....	25	0	0
Respiration of Plants .....	12	0	0
Conditions of Health essential for School Instruction .....	5	0	0
Corresponding Societies Committee .....	20	0	0
	<u>£845</u>	<u>13</u>	<u>2</u>

## 1904.

Seismological Observations...	40	0	0
Investigation of the Upper Atmosphere by means of Kites .....	50	0	0
Magnetic Observations at Falmouth .....	60	0	0
Wave-length Tables of Spectra	10	0	0
Study of Hydro-aromatic Substances .....	25	0	0
Erratic Blocks .....	10	0	0
Life-zones in British Carboniferous Rocks .....	35	0	0
Fauna and Flora of the Trias .....	10	0	0
Investigation of Fossiliferous Drifts .....	50	0	0
Table at the Zoological Station, Naples .....	100	0	0
Index Generum et Specierum Animalium .....	60	0	0
Development in the Frog.....	15	0	0
Researches on the Higher Crustacea .....	15	0	0
British and Foreign Statistics of International Trade.....	25	0	0
Resistance of Road Vehicles to Traction.....	90	0	0
Researches in Crete	100	0	0
Researches in Glastonbury Lake Village .....	25	0	0

	£	s.	d.
Anthropometric Investigation of Egyptian Troops .....	8	10	0
Excavations on Roman Sites in Britain .....	25	0	0
The State of Solution of Proteids.....	20	0	0
Metabolism of Individual Tissues.....	40	0	0
Botanical Photographs .....	4	8	11
Respiration of Plants... ..	15	0	0
Experimental Studies in Heredity .....	35	0	0
Corresponding Societies Committee .....	20	0	0
	<u>£887</u>	<u>18</u>	<u>11</u>

## 1905.

Electrical Standards.....	40	0	0
Seismological Observations...	40	0	0
Investigation of the Upper Atmosphere by means of Kites .....	40	0	0
Magnetic Observations at Falmouth .....	50	0	0
Wave-length Tables of Spectra .....	5	0	0
Study of Hydro-aromatic Substances .....	25	0	0
Dynamic Isomerism .....	20	0	0
Aromatic Nitroamines .....	25	0	0
Fauna and Flora of the British Trias .....	10	0	0
Table at the Zoological Station, Naples .....	100	0	0
Index Generum et Specierum Animalium .....	75	0	0
Development of the Frog ...	10	0	0
Investigations in the Indian Ocean .....	150	0	0
Trade Statistics.....	4	4	8
Researches in Crete .....	75	0	0
Anthropometric Investigations of Egyptian Troops...	10	0	0
Excavations on Roman Sites in Britain .....	10	0	0
Anthropometric Investigations	10	0	0
Age of Stone Circles.....	30	0	0
The State of Solution of Proteids.....	20	0	0
Metabolism of Individual Tissues .....	30	0	0
Ductless Glands.....	40	0	0
Botanical Photographs.....	3	17	6
Physiology of Heredity.....	35	0	0
Structure of Fossil Plants .....	50	0	0
Corresponding Societies Committee .....	20	0	0
	<u>£928</u>	<u>2</u>	<u>2</u>

1906.		£ s. d.				£ s. d.	
Electrical Standards.....	25	0	0	Correlation and Age of South African Strata, &c. ....	10	0	0
Seismological Observations...	40	0	0	Table at the Zoological Station, Naples .....	100	0	0
Magnetic Observations at Falmouth .....	50	0	0	Index Animalium .....	75	0	0
Magnetic Survey of South Africa .....	99	12	6	Development of the Sexual Cells .....	1	11	8
Wave-length Tables of Spectra .....	5	0	0	Oscillations of the Land Level in the Mediterranean Basin .....	50	0	0
Study of Hydro-aromatic Substances.....	25	0	0	Gold Coinage in Circulation in the United Kingdom ...	8	19	7
Aromatic Nitroamines .....	10	0	0	Anthropometric Investigations in the British Isles...	10	0	0
Fauna and Flora of the British Trias .....	7	8	11	Metabolism of Individual Tissues .....	45	0	0
Crystalline Rocks of Anglesey Table at the Zoological Station, Naples .....	30	0	0	The Ductless Glands .....	25	0	0
Index Animalium .....	75	0	0	Effect of Climate upon Health and Disease .....	55	0	0
Development of the Frog.....	10	0	0	Physiology of Heredity .....	30	0	0
Higher Crustacea .....	15	0	0	Research on South African Cycads.....	35	0	0
Freshwater Fishes of South Africa .....	50	0	0	Botanical Photographs.....	5	0	0
Rainfall and Lake and River Discharge .....	10	0	0	Structure of Fossil Plants ...	5	0	0
Excavations in Crete .....	100	0	0	Marsh Vegetation.....	15	0	0
Lake Village at Glastonbury .....	40	0	0	Corresponding Societies Committee.....	16	14	1
Excavations on Roman Sites in Britain .....	30	0	0		<u>£757 12 10</u>		
Anthropometric Investigations in the British Isles ...	30	0	0		1908.		
State of Solution of Proteids .....	20	0	0	Seismological Observations ...	40	0	0
Metabolism of Individual Tissues .....	20	0	0	Further Tabulation of Bessel Functions .....	15	0	0
Effect of Climate upon Health and Disease.....	20	0	0	Investigation of Upper Atmosphere by means of Kites...	25	0	0
Research on South African Cycads.....	14	19	4	Meteorological Observations on Ben Nevis.....	25	0	0
Peat Moss Deposits .....	25	0	0	Geodetic Arc in Africa.....	200	0	0
Studies suitable for Elementary Schools .....	5	0	0	Wave-length Tables of Spectra .....	10	0	0
Corresponding Societies Committee .....	25	0	0	Study of Hydro-aromatic Substances.....	30	0	0
	<u>£882</u>		0 9	Dynamic Isomerism .....	40	0	0
	1907.			Transformation of Aromatic Nitroamines .....	30	0	0
Electrical Standards .....	50	0	0	Erratic Blocks .....	17	16	6
Seismological Observations...	40	0	0	Fauna and Flora of British Trias .....	10	0	0
Magnetic Observations at Falmouth .....	40	0	0	Faunal Succession in the Carboniferous Limestone in the British Isles .....	10	0	0
Magnetic Survey of South Africa .....	25	7	6	Pre-Devonian Rocks.....	10	0	0
Wave-length Tables of Spectra .....	10	0	0	Exact Significance of Local Terms .....	5	0	0
Study of Hydro-aromatic Substances.....	30	0	0	Composition of Charnwood Rocks .....	10	0	0
Dynamic Isomerism .....	30	0	0	Table at the Zoological Station at Naples.....	100	0	0
Life Zones in British Carboniferous Rocks .....	10	0	0	Index Animalium .....	75	0	0
Erratic Blocks .....	10	0	0	Hereditary Experiments .....	10	0	0
Fauna and Flora of British Trias .....	10	0	0	Fauna of Lakes of Central Tasmania .....	40	0	0
Faunal Succession in the Carboniferous Limestone of South-West England .....	15	0	0	Investigations in the Indian Ocean .....	50	0	0

	£	s.	d.
Exploration in Spitsbergen ...	30	0	0
Gold Coinage in Circulation in the United Kingdom.....	3	7	6
Electrical Standards .....	50	0	0
Glastonbury Lake Village ...	30	0	0
Excavations on Roman Sites in Britain .....	15	0	0
Age of Stone Circles.....	50	0	0
Anthropological Notes and Queries .....	40	0	0
Metabolism of Individual Tissues.....	40	0	0
The Ductless Glands.....	13	14	8
Effect of Climate upon Health and Disease.....	35	0	0
Body Metabolism in Cancer...	30	0	0
Electrical Phenomena and Metabolism of <i>Arum Spa-</i> <i>diæes</i> .....	10	0	0
Marsh Vegetation .....	15	0	0
Succession of Plant Remains	18	0	0
Corresponding Societies Com- mittee .....	25	0	0
	<hr/>		
	£1,157	18	8

## 1909.

Seismological Observations...	60	0	0
Investigation of the Upper At- mosphere by means of Kites	10	0	0
Magnetic Observations at Falmouth .....	50	0	0
Establishing a Solar Ob- servatory in Australia .....	50	0	0
Wave-length Tables of Spectra	9	16	0
Study of Hydro-aromatic Sub- stances .....	15	0	0
Dynamic Isomerism.....	35	0	0
Transformation of Aromatic Nitroamines .....	10	0	0
Electroanalysis .....	30	0	0
Fauna and Flora of British Trias .....	8	0	0
Faunal Succession in the Car- boniferous Limestone in the British Isles .....	8	0	0
Palæozoic Rocks of Wales and the West of England .....	9	0	0
Igneous and Associated Sedi- mentary Rocks of Glensaul	11	13	9
Investigations at Biskra .....	50	0	0
Table at the Zoological Station at Naples .....	100	0	0
Heredity Experiments.....	10	0	0
Feeding Habits of British Birds .....	5	0	0
Index Animalium.....	75	0	0
Investigations in the Indian Ocean .....	35	0	0
Gaseous Explosions .....	75	0	0
Excavations on Roman Sites in Britain .....	5	0	0
Age of Stone Circles.....	30	0	0
Researches in Crete .....	70	0	0

	£	s.	d.
The Ductless Glands .....	35	0	0
Electrical Phenomena and Me- tabolism of <i>Arum Spadiæes</i>	10	0	0
Reflex Muscular Rhythm.....	10	0	0
Anæsthetics .....	25	0	0
Mental and Muscular Fatigue	27	0	0
Structure of Fossil Plants ...	5	0	0
Botanical Photographs.....	10	0	0
Experimental Study of Heredity.....	30	0	0
Symbiosis between Tur- bellarian Worms and Algæ	10	0	0
Survey of Clare Island.....	65	0	0
Curricula of Secondary Schools	5	0	0
Corresponding Societies Com- mittee .....	21	0	0
	<hr/>		
	£1,014	9	9

## 1910.

Measurement of Geodetic Arc in South Africa.....	100	0	0
Republication of Electrical Standards Reports .....	100	0	0
Seismological Observations...	60	0	0
Magnetic Observations at Falmouth .....	25	0	0
Investigation of the Upper Atmosphere .....	25	0	0
Study of Hydro-aromatic Sub- stances .....	25	0	0
Dynamic Isomerism.....	35	0	0
Transformation of Aromatic Nitroamines .....	15	0	0
Electroanalysis .....	10	0	0
Faunal Succession in the Car- boniferous Limestone in the British Isles .....	10	0	0
South African Strata .....	5	0	0
Fossils of Midland Coalfields	25	0	0
Table at the Zoological Sta- tion at Naples .....	100	0	0
Index Animalium .....	75	0	0
Heredity Experiments .....	15	0	0
Feeding Habits of British Birds .....	5	0	0
Amount and Distribution of Income .....	15	0	0
Gaseous Explosions .....	75	0	0
Lake Villages in the neigh- bourhood of Glastonbury...	5	0	0
Excavations on Roman Sites in Britain .....	5	0	0
Neolithic Sites in Northern Greece.....	5	0	0
The Ductless Glands .....	40	0	0
Body Metabolism in Cancer...	20	0	0
Anæsthetics .....	25	0	0
Tissue Metabolism .....	25	0	0
Mental and Muscular Fatigue	18	17	0
Electromotive Phenomena in Plants .....	10	0	0
Structure of Fossil Plants ...	10	0	0
Experimental Study of Heredity.....	30	0	0

	£	s.	d.		£	s.	d.
Survey of Clare Island .....	30	0	0	Investigation of the Upper Atmosphere .....	30	0	0
Corresponding Societies Committee .....	20	0	0	International Commission on Physical and Chemical Constants .....	30	0	0
	<u>£963 17 0</u>			Further Tabulation of Bessel Functions .....	15	0	0
1911.				Study of Hydro-aromatic Substances.....	20	0	0
Seismological Investigations	60	0	0	Dynamic Isomerism .....	25	0	0
Magnetic Observations at Falmouth .....	25	0	0	Transformation of Aromatic Nitroamines .....	15	0	0
Investigation of the Upper Atmosphere .....	25	0	0	Electroanalysis .....	15	0	0
International Commission on Physical and Chemical Constants .....	30	0	0	Influence of Carbon, &c., on Corrosion of Steel.....	15	0	0
Study of Hydro-aromatic Substances .....	20	0	0	Crystalline Rocks of Anglesey	2	0	0
Dynamic Isomerism .....	25	0	0	Mammalian Fauna in Miocene Deposits, Bugti Hills, Baluchistan .....	75	0	0
Transformation of Aromatic Nitroamines .....	15	0	0	Table at the Zoological Station at Naples .....	100	0	0
Electroanalysis .....	15	0	0	Index Animalium .....	75	0	0
Influence of Carbon, &c., on Corrosion of Steel.....	15	0	0	Feeding Habits of British Birds .....	5	0	0
Crystalline Rocks of Anglesey	2	0	0	Belmullet Whaling Station...	30	0	0
Mammalian Fauna in Miocene Deposits, Bugti Hills, Baluchistan .....	75	0	0	Map of Prince Charles Foreland.....	30	0	0
Table at the Zoological Station at Naples .....	100	0	0	Gaseous Explosions ...	90	0	0
Index Animalium .....	75	0	0	Lake Villages in the neighbourhood of Glastonbury...	5	0	0
Feeding Habits of British Birds .....	5	0	0	Age of Stone Circles.....	30	0	0
Belmullet Whaling Station...	30	0	0	Artificial Islands in Highland Lochs .....	10	0	0
Map of Prince Charles Foreland.....	30	0	0	The Ductless Glands.....	40	0	0
Gaseous Explosions ...	90	0	0	Anæsthetics .....	20	0	0
Lake Villages in the neighbourhood of Glastonbury...	5	0	0	Mental and Muscular Fatigue	25	0	0
Age of Stone Circles.....	30	0	0	Electromotive Phenomena in Plants .....	10	0	0
Artificial Islands in Highland Lochs .....	10	0	0	Dissociation of Oxy-Hæmoglobin .....	25	0	0
The Ductless Glands.....	40	0	0	Structure of Fossil Plants ...	15	0	0
Anæsthetics .....	20	0	0	Experimental Study of Heredity .....	45	0	0
Mental and Muscular Fatigue	25	0	0	Survey of Clare Island.....	20	0	0
Electromotive Phenomena in Plants .....	10	0	0	Registration of Botanical Photographs .....	10	0	0
Dissociation of Oxy-Hæmoglobin .....	25	0	0	Mental and Physical Factors involved in Education .....	10	0	0
Structure of Fossil Plants ...	15	0	0	Corresponding Societies Committee .....	20	0	0
Experimental Study of Heredity .....	45	0	0		<u>£922 0 0</u>		
Survey of Clare Island.....	20	0	0	1912.			
Registration of Botanical Photographs .....	10	0	0	Seismological Investigations	60	0	0
Mental and Physical Factors involved in Education .....	10	0	0	Investigation of the Upper Atmosphere .....	50	0	0
Corresponding Societies Committee .....	20	0	0	International Commission on Physical and Chemical Constants .....	40	0	0
	<u>£922 0 0</u>				<u>£845 7 6</u>		
1913.				Seismological Investigations	60	0	0
Seismological Investigations	60	0	0	Investigation of the Upper Atmosphere .....	50	0	0
Magnetic Observations at Falmouth .....	25	0	0	International Commission on Physical and Chemical Constants .....	40	0	0

	£	s.	d.		£	s.	d.
Further Tabulation of Bessel Functions .....	30	0	0	Study of Hydro-aromatic Substances .....	15	0	0
Study of Hydro-aromatic Substances .....	20	0	0	Dynamic Isomerism .....	25	0	0
Dynamic Isomerism .....	30	0	0	Transformation of Aromatic Nitroamines .....	15	0	0
Transformation of Aromatic Nitroamines .....	20	0	0	Study of Plant Enzymes .....	25	0	0
Study of Plant Enzymes .....	30	0	0	Correlation of Crystalline Form with Molecular Structure .....	25	0	0
Igneous and Associated Rocks of Glensaul, &c .....	10	0	0	Study of Solubility Pheno- mena .....	10	0	0
List of Characteristic Fossils Exploration of the Upper Old Red Sandstone of Dura Den .....	75	0	0	List of Characteristic Fossils .....	5	0	0
Geology of Ramsey Island ...	10	0	0	Geology of Ramsey Island ...	10	0	0
Old Red Sandstone Rocks of Kiltorcan .....	15	0	0	Fauna and Flora of Trias of Western Midlands .....	10	0	0
Table at the Zoological Station at Naples .....	50	0	0	Critical Sections in Lower Palæozoic Rocks .....	15	0	0
Ditto (Special Grant) .....	50	0	0	Belmullet Whaling Station ...	20	0	0
Nomenclator Animalium Generum et Sub-generum .....	100	0	0	Nomenclator Animalium Generum et Sub-generum .....	50	0	0
Belmullet Whaling Station ...	15	0	0	Antarctic Whaling Industry .....	75	0	0
Ditto (Special Grant) .....	10	0	0	Maps for School and Univer- sity Use .....	40	0	0
Gaseous Explosions .....	80	0	0	Gaseous Explosions .....	50	0	0
Lake Villages in the Neigh- bourhood of Glastonbury ...	5	0	0	Stress Distributions in Engi- neering Materials .....	50	0	0
Age of Stone Circles (Special Grant) .....	15	0	0	Lake Villages in the Neigh- bourhood of Glastonbury ...	20	0	0
Artificial Islands in the High- lands of Scotland .....	5	0	0	Age of Stone Circles .....	20	0	0
Excavations on Roman Sites in Britain .....	15	0	0	Artificial Islands in the High- lands of Scotland .....	5	0	0
Hausa Manuscripts .....	20	0	0	Excavations on Roman Sites in Britain .....	20	0	0
The Ductless Glands .....	40	0	0	Anthropometric Investiga- tions in Cyprus .....	50	0	0
Calorimetric Observations on Man .....	45	0	0	Palæolithic Site in Jersey ...	50	0	0
Dissociation of Oxy-Hæmo- globin at High Altitudes ...	15	0	0	The Ductless Glands .....	35	0	0
Structure and Function of the Mammalian Heart .....	20	0	0	Calorimetric Observations on Man .....	40	0	0
Structure of Fossil Plants ...	15	0	0	Structure and Function of the Mammalian Heart .....	30	0	0
Jurassic Flora of Yorkshire Vegetation of Ditcham Park, Hampshire .....	4	12	4	Binocular Combination of Kinematograph Pictures ...	0	17	0
Influence of School Books on Eyesight .....	9	4	9	Structure of Fossil Plants ...	15	0	0
Corresponding Societies Com- mittee .....	25	0	0	Jurassic Flora of Yorkshire Flora of the Peat of the Kennet Valley .....	15	0	0
£978 17 1				Vegetation of Ditcham Park .....	14	4	3
				Physiology of Heredity .....	30	0	0
1914.				Breeding Experiments with Cenotheras .....	19	17	4
Seismological Investigations .....	130	0	0	Mental and Physical Fac- tors involved in Educa- tion .....	20	0	0
Investigation of the Upper Atmosphere .....	25	0	0	Influence of School Books on Eyesight .....	2	8	9
International Commission on Physical and Chemical Constants .....	40	0	0	Character, Work, and Main- tenance of Museums .....	10	0	0
Calculation of Mathematical Tables .....	20	0	0	Corresponding Societies Com- mittee .....	25	0	0
Disposal of Copies of the 'Binary Canon' .....	4	9	0	£1,086 16 4			

1915.					£ s. d.		
	£	s.	d.				
Seismological Investigations	130	0	0	Physical Characters of Ancient Egyptians .....	12	8	1
Tables of Constants .....	40	0	0	Palæolithic Site in Jersey ...	25	0	0
Mathematical Tables .....	35	0	0	Distribution of Bronze Age Implements.....	3	5	9
Dynamic Isomerism .....	20	0	0	Ductless Glands (1914).....	35	0	0
Non-Aromatic Diazonium Salts.....	8	10	0	" " (1915).....	14	0	0
Old Red Sandstone Rock of Kiltorcan.....	7	0	0	Physiology of Heredity .....	45	0	0
Old Red Sandstone Rock of Rhynie.....	25	0	0	Renting of Cinchona Station	12	10	0
Belmullet Whaling Station ...	25	0	0	Mental and Physical Factors involved in Education .....	20	0	0
Fatigue from Economic Standpoint .....	20	0	0	School Books and Eyesight... ..	3	5	0
Industrial Unrest .....	20	0	0	Museums.....	15	0	0
Women in Industry .....	90	0	0	Free Place System .....	10	0	0
Effect of War on Credit .....	25	0	0	Corresponding Societies Committee .....	25	0	0
Stress Distributions .....	40	0	0		<u>£715 18 10</u>		
Engineering Problems affecting the Prosperity of the Country .....	10	0	0				

## GENERAL MEETINGS AT NEWCASTLE-UPON-TYNE.

On Tuesday, September 5, at 8.30 P.M., in the Town Hall, Professor Arthur Schuster, F.R.S., resigned the office of President to Sir Arthur Evans, F.R.S. Before vacating the chair, Professor Schuster referred to eminent members of the Association who had died since the previous meeting. These included the following:—

The Right Hon. Sir Henry E. Roscoe, F.R.S., President, 1887.

Sir Arthur W. Rücker, F.R.S., President, 1901; Trustee, 1898–1915; General Treasurer, 1891–98.

Sir William Turner, K.C.B., F.R.S., President, 1900.

Sir William Ramsay, K.C.B., F.R.S., President, 1911.

Sir Andrew Noble, Bart., K.C.B., F.R.S., President of Section G, 1890.

Professor R. Meldola, F.R.S., President of Section B, 1895.

Professor Silvanus P. Thompson, F.R.S., President of Section G, 1907.

Professor E. A. Minchin, F.R.S., President of Section D, 1915.

Sir Arthur Evans then delivered an Address, for which see page 8.

On Wednesday evening, September 6, at 8 P.M., an informal conversazione was held at the Laing Art Gallery.

On Thursday, September 7, at 8.30 P.M., in the Town Hall, Professor W. A. Bone, F.R.S., delivered a discourse on 'Flame and Flameless Combustion.'

On Friday, September 8, at 8.30 P.M., in the Town Hall, Dr. P. Chalmers Mitchell, F.R.S., delivered a discourse on 'Evolution and the War.'

After the above discourse (the occasion being the concluding General Meeting), the following resolution was unanimously adopted on the motion of the President:—

That the cordial thanks of the British Association be extended to the Right Hon. the Lord Mayor and Corporation and the Citizens of the City of Newcastle for their hearty welcome, to the Presidents and Councils of the University of Durham College of Medicine and of the Armstrong College, and to the North-East Coast Institution of Engineers and Ship-builders and other Institutions which have kindly placed their buildings and resources at the disposal of the Association, to the Directors of the North-Eastern Railway Company, and, finally, to the Honorary Local Officers and their able assistants, and to the General and Executive Committees and individual members thereof, for the admirable arrangements made for the Meeting under exceptional and trying circumstances.

## OFFICERS OF SECTIONS AT THE NEWCASTLE MEETING, 1916.

### SECTION A.—MATHEMATICAL AND PHYSICAL SCIENCE.

*President.*—Prof. A. N. Whitehead, Sc.D., F.R.S. *Vice-Presidents.*—Sir F. W. Dyson, M.A., LL.D., F.R.S.; Prof. T. H. Havelock, M.A., F.R.S.; Prof. Sir E. Rutherford, D.Sc., F.R.S. *Secretaries.*—Prof. A. S. Eddington, M.A., M.Sc., F.R.S. (*Recorder*); H. R. Hassé; A. O. Rankine, D.Sc.; W. Makower, M.A., D.Sc.; G. M. Caunt, M.A., M.Sc.

## SECTION B.—CHEMISTRY.

*President.*—Prof. G. G. Henderson, D.Sc., LL.D., F.R.S. *Vice-Presidents.*—Prof. W. A. Bone, D.Sc., F.R.S.; J. T. Dunn, D.Sc.; J. E. Stead, D.Sc., F.R.S. *Secretaries.*—A. Holt, D.Sc. (*Recorder*); C. H. Desch, D.Sc., Ph.D.; Prof. R. Robinson, D.Sc.; J. A. Smythe, Ph.D., D.Sc.

## SECTION C.—GEOLOGY.

*President.*—Prof. W. S. Boulton, D.Sc. *Vice-Presidents.*—J. W. Evans, D.Sc.; Prof. G. A. Lebour, D.Sc.; Prof. P. F. Kendall, M.Sc.; J. W. Flett, D.Sc. *Secretaries.*—W. Lower Carter, M.A. (*Recorder*); W. T. Gordon, D.Sc.; G. Hickling, D.Sc.; D. Woolacott, D.Sc.

## SECTION D.—ZOOLOGY.

*President.*—Prof. E. W. MacBride, D.Sc., F.R.S. *Vice-Presidents.*—Dr. F. A. Dixey, F.R.S.; Prof. A. Meek, D.Sc. *Secretaries.*—J. H. Ashworth, D.Sc. (*Recorder*); R. Douglas Laurie, M.A.; R. A. H. Gray, M.A., M.Sc.

## SECTION E.—GEOGRAPHY.

*President.*—Edward A. Reeves, F.R.G.S. *Vice-Presidents.*—Rev. W. J. Barton; Prof. M. R. Wright; Sir T. H. Holdich, K.C.B.; Sir Thomas Oliver; Dr. W. S. Bruce. *Secretaries.*—J. McFarlane, M.A. (*Recorder*); Dr. R. N. Rudmose Brown; B. C. Wallis; Herbert Shaw.

## SECTION F.—ECONOMIC SCIENCE AND STATISTICS.

*President.*—Prof. A. W. Kirkaldy, M.A., M.Com. *Vice-Presidents.*—Sir Hugh Bell, Bart.; Principal Hadow, M.A.; Dr. G. B. Hunter; Prof. W. R. Scott, M.A.; Miss E. Stevenson. *Secretaries.*—Miss Ashley, M.A. (*Recorder*); C. R. Fay, M.A.; E. J. W. Jackson, B.A.; Prof. H. M. Hallsworth; J. Cunnison.

## SECTION G.—ENGINEERING.

*President.*—G. G. Stoney, B.A., F.R.S. *Vice-Presidents.*—H. S. Hele-Shaw, D.Sc., F.R.S.; Summers Hunter; Prof. H. Louis, D.Sc.; C. H. Merz, M.Inst.C.E.; E. L. Orde; H. Rowell; Prof. R. L. Weighton, D.Sc.; Col. R. Saxton White. *Secretaries.*—Prof. G. W. O. Howe, D.Sc. (*Recorder*); Prof. E. W. Marchant, D.Sc.; Prof. W. M. Thornton, D.Sc.

## SECTION H.—ANTHROPOLOGY.

*President.*—R. R. Marett, D.Sc. *Vice-Presidents.*—Prof. A. Keith, M.D., F.R.S.; F. B. Jevons, D.Litt.; Prof. C. G. Seligman, M.D.; Prof. R. Howden, M.D.; R. H. Forster, M.A., LL.B. *Secretaries.*—F. C. Shruballs, M.A., M.D. (*Recorder*); Rev. E. O. James, B.Litt.; E. P. Stibbe, L.R.C.P., M.R.C.S.

## SECTION I.—PHYSIOLOGY.

*President.*—Prof. A. R. Cushny, M.A., M.D., F.R.S. *Vice-Presidents.*—D. Drummond, M.D.; Prof. W. D. Halliburton, M.D., F.R.S.; Prof. T. Loveday; Prof. Sir T. Oliver, M.D.; Prof. A. Robinson; Prof. Sir Edward A. Schäfer, M.D., F.R.S.; Prof. E. H. Starling, M.D., F.R.S.; Prof. A. D. Waller, M.D., F.R.S. *Secretaries.*—Prof. P. T. Herring, M.D. (*Recorder*); C. L. Burt, M.A.; Prof. J. A. Menzies, M.A., M.D.



## SECTION K.—BOTANY.

*President.*—A. B. Rendle, M.A., D.Sc., F.R.S. *Vice-Presidents.*—Prof. F. O. Bower, F.R.S.; Prof. W. H. Lang, M.B., F.R.S.; Prof. M. C. Potter, M.A.; Prof. A. O. Seward, F.R.S.; H. W. T. Wager, F.R.S.; Prof. R. H. Yapp, M.A. *Secretaries.*—D. Thoday, M.A. (*Recorder*); R. C. Davie, M.A.; Miss E. N. Thomas, D.Sc.; J. Small.

## SECTION L.—EDUCATIONAL SCIENCE.

*President.*—Rev. W. Temple, M.A. *Vice-Presidents.*—Principal W. H. Hadow, M.A.; Mrs. H. Sidgwick. *Secretaries.*—Prof. J. A. Green, M.A. (*Recorder*); D. Berridge, M.A.; Dr. E. H. Tripp; Percival Sharp, B.Sc.

## SECTION M.—AGRICULTURE.

*President.*—E. J. Russell, D.Sc. *Vice-Presidents.*—Sir Sydney Olivier, K.C.M.G.; T. H. Middleton, C.B.; Prof. T. B. Wood, M.A.; Prof. D. A. Gilchrist, Ph.D.; Sir R. H. Rew, K.C.B.; Prof. W. Somerville, D.Sc. *Secretaries.*—Prof. C. Crowther, M.A., Ph.D. (*Recorder*); A. Lauder, D.Sc.; S. Hoare Collins, M.Sc.

---

CONFERENCE OF DELEGATES OF CORRESPONDING SOCIETIES.

*President.*—Prof. G. A. Lebour, M.A., D.Sc., F.G.S. *Vice-President.*—Thomas Sheppard, M.Sc., F.G.S. *Secretary.*—Wilfred Mark Webb, F.L.S.

---

## REPORT OF THE COUNCIL, 1915-16.

I. The Council during the past year have had to deplore the death of Sir A. W. RÜCKER (ex-President, ex-General Treasurer, and a Trustee of the Association), Sir HENRY ROSCOE, Sir WILLIAM TURNER, and Sir WILLIAM RAMSAY (ex-Presidents), and Sir J. K. CAIRD, a benefactor of the Association.

II. The Hon. Sir C. A. PARSONS has been unanimously nominated by the Council to fill the office of President of the Association for 1917-18 (Bournemouth Meeting).

III. Resolutions received by the General Committee at Manchester, and referred to the Council for consideration and, if desirable, for action, were dealt with as follows:—

*From Section A.*

‘ That the Council places upon record its high appreciation of the assistance rendered to the investigation of the value of gravity at sea by the directors of Messrs. Alfred Holt of Liverpool during the voyage of the British Association to Australia in 1914. The Association is indebted to them for the generous installation of a special refrigerating chamber for the purpose of this research and for placing at the disposal of the experimenter (Dr. Duffield) the whole of the resources of the Blue Funnel steamship “Ascanius”: in this respect the help of Captain Chrimes, Chief Engineer Douglas, and Refrigerating Engineer Latham deserves particular mention. The Association regrets that the outbreak of war prevented full advantage being taken of the facilities so kindly made available by Messrs. Alfred Holt, but it is none the less grateful for their valuable and whole-hearted co-operation.

‘ That a copy of the above resolution be forwarded to Messrs. Alfred Holt.’

It was unanimously resolved that the above resolution be adopted and that a copy be forwarded to Messrs. Alfred Holt.

*From Section B.*

‘ To recommend to the Council that the proceedings of Section B, together with the reports of Research Committees, including any reports on special branches of chemical science, be published separately from the annual volume of Reports.’

In the course of a general inquiry into the possibilities of economy in printing at the present time, the Council decided that it would be inexpedient under existing conditions to give effect to the above resolution.

IV. A proposal for the constitution of a committee on organisation in relation to problems arising out of the war was brought before the Council. The following committee was appointed to consider and report upon this proposal:—

The President and General Officers, the President-Elect, Sir E. Brabrook, Mr. A. D. Hall, Dr. H. S. Hele-Shaw, Professor R. Meldola, and Professor C. S. Sherrington.

This Committee presented the following Report :—

The Committee recommends :—

(a) That the Organising Committees of Sections should have power to report direct to the Council at any time when the Association is not in Session at its Annual Meeting.

(b) That a Research Committee should have power to send reports at any time, through the Organising Committee of its Section, to the Council.

The Committee recommends the Council to give immediate effect to this arrangement, and to inform all members of Organising Sectional Committees accordingly, and to call upon those Committees to meet in order to consider :—

(a) What problems, if any, arise in their special departments of science which call for investigation in the present connexion (*i.e.*, in connexion with the future effects of the war upon the national and imperial welfare).

(b) The proper methods of investigation of such problems.

The Committee recommends that it be reappointed, with additional members, and with power to initiate questions to be submitted to the Organising Sectional Committees, and to receive reports from them and transmit such reports to the Council.

The Council resolved that the Committee be reappointed with the addition of Prof. W. A. Bone, Dr. Dugald Clerk, Major Lyons, and Dr. A. Strahan. The Committee was empowered to consult the Organising Committees on the questions indicated in the Report, and it was further resolved :—

(a) That Organising Committees of Sections should have power to report direct to the Council at any time when the Association is not in annual session, and that it be recommended to the General Committee that the Rule, chap. ix., 6 (second paragraph), be amended to read as follows :—

‘ Each Organising Committee shall hold . . . meetings . . . for the organisation of the ensuing Sectional proceedings, and may at any such meeting resolve to present a report to the Council upon any matter of interest to the Section, and shall hold . . . etc.’

(b) That Research Committees should have power to report through Organising Committees to the Council at any time when the Association is not in annual session, and that it be recommended to the General Committee that the Rule, chap. iv., 5, be amended to read as follows :—

‘ Every Research Committee shall present a report . . . at the Annual Meeting next after that at which it was appointed or reappointed, and may in the meantime present a report through a Sectional Organising Committee to the Council.’

A number of valuable proposals, received by the Committee from the Organising Sectional Committees, have been transmitted to the Council, and action arising out of several of these is proceeding.

V. With a view to facilitating the work of Research Committees, the Council have resolved to recommend to the General Committee that the Rule, chap. iv., 1, be amended by the *omission* of the words italicised below:—

A Sectional Committee may recommend the appointment of a Research Committee, *composed of Members of the Association* to conduct research . . . and the Committee of Recommendation may include such recommendation in their Report to the General Committee.

and by the *addition*, after the above clause, of the following:—

Such Research Committee shall be composed of Members of the Association, provided that the Council shall have power to consider, and in its discretion to approve, any recommendation to include in such Committee any person, not being a Member of the Association, whose assistance may be regarded as of special importance to the research undertaken.

VI. Professors J. PERRY and W. A. HERDMAN were appointed to represent the Association at a Conference called by the Royal Society to discuss a proposal for a Conjoint Board of Scientific Societies.

Professors J. PERRY and H. H. TURNER were appointed to represent the Association at a Meeting called by the Committee on the Neglect of Science.

VII. It was unanimously resolved that the renewed invitation to hold the Annual Meeting in Newcastle-upon-Tyne in 1916 be accepted with pleasure.

VIII. The Council have received reports from the General Treasurer during the past year. The accounts have been audited and are presented to the General Committee.

The General Treasurer has reported that Mr. M. DESHUMBERT proposed to leave a legacy of about £5,000 to the Association, subject to the condition that his wife and her sister should receive the interest during their lifetime.

It was resolved that the thanks of the Council be conveyed to Mr. Deshumbert.

IX. CAIRD FUND.—The Council has made the following grants from the income of the fund during the year:—

For aid in transplanting the private observatory of the	£
Rev. T. E. R. Phillips . . . . .	20
To Committee on Fuel Economy . . . . .	25

X. CONFERENCE OF DELEGATES and CORRESPONDING SOCIETIES COMMITTEE:—

The following nominations are made by the Council:—

*Conference of Delegates.*—Professor G. A. Lebour (*President*), Mr. T. Sheppard (*Vice-President*), Mr. W. Mark Webb (*Secretary*).

*Corresponding Societies Committee.*—Mr. W. Whitaker (*Chairman*), Mr. W. Mark Webb (*Secretary*), Rev. J. O. Bevan, Sir Edward Brabrook, Sir H. G. Fordham, Dr. J. G. Garson, Principal E. H. Griffiths, Dr. A. C. Haddon, Mr. T. V. Holmes, Mr. J. Hopkinson, Mr. A. L. Lewis, Rev. T. R. R. Stebbing, and the President and General Officers of the Association.

XI. The retiring members of the Council are :—

*By seniority.*—Prof. H. E. Armstrong, Prof. J. L. Myres, Sir J. J. H. Teall.

*By resignation.*—Mr. W. Crooke, Prof. T. B. Wood.

The Council has nominated the following new members :—

Prof. R. A. Gregory,  
Dr. S. F. Harmer,  
Dr. A. Strahan,

leaving two vacancies to be filled by the General Committee without nomination by the Council.

The full list of nominations of ordinary members is as follows :—

Prof. W. A. Bone.  
Sir E. Brabrook.  
Prof. W. H. Bragg.  
Dr. Dugald Clerk.  
Prof. A. Dendy.  
Prof. H. N. Dickson.  
Dr. F. A. Dixey.  
Prof. H. B. Dixon.  
Sir F. W. Dyson.  
Prof. R. A. Gregory.  
Principal E. H. Griffiths.

Dr. A. C. Haddon.  
Prof. W. D. Halliburton.  
Dr. S. F. Harmer.  
Sir Everard im Thurn.  
Sir D. Morris.  
Sir E. Rutherford.  
Miss E. R. Saunders.  
Prof. E. H. Starling.  
Dr. A. Strahan.  
Prof. F. E. Weiss.  
Dr. A. Smith Woodward.

XII. Dr. G. CAREY FOSTER, who has acted as a Trustee of the Association in the room of the late Sir A. W. Rücker during the past year, has been nominated for appointment to that office.

XIII. THE GENERAL OFFICERS have been nominated by the Council as follows :—

*General Treasurer* : Prof. J. Perry.  
*General Secretaries* : Prof. W. A. Herdman.  
Prof. H. H. Turner.

XIV. Dr. J. A. SMYTHE has been admitted a member of the General Committee.

XV. Dr. G. E. HALE and Dr. W. H. WELCH have been elected Honorary Corresponding Members.

XVI. Professors J. PERRY and W. A. HERDMAN have been appointed to represent the Association on the Conjoint Board of Scientific Societies.

*Dr.* THE GENERAL TREASURER IN ACCOUNT  
ADVANCEMENT OF SCIENCE,

RECEIPTS.

	£ s. d.	£ s. d.	£ s. d.
To Balance brought forward :—			
Lloyds Bank, Birmingham .....	1,718	9 11	
Commonwealth Bank of Australia .....	3,227	0 1	
Bank of England—Western Branch :—			
On ' Caird Fund ' .....	92	3 1	
<i>Less</i> General Account overdrawn .....	49	10 8	
		42	12 5
Life Composition (including Transfers) .....			4,988 2 5
Annual Subscriptions .....			257 0 0
New Annual Members' Subscriptions .....			613 0 0
Sale of Associates' Tickets .....			252 0 0
Sale of Ladies' Tickets .....			551 0 0
Sale of Publications .....			141 0 0
Donation .....			258 13 1
Interest on Deposit, Lloyds Bank, Birmingham .....	51	3 1	
" " Commonwealth Bank of Australia .....	24	7 2	
" " Williams Deacons Bank, Manchester .....	27	7 5	
			102 17 8
Unexpended Balances of Grants returned .....			43 12 1
Dividends on Investments :—			
Consols 2½ per Cent. ....	110	6 8	
India 3 per Cent. ....	91	16 0	
Great Indian Peninsula Railway ' B ' Annuity .....	26	14 5	
War Loan 4½ per Cent. ....	77	17 0	
			306 14 1
Dividends on ' Caird Fund ' Investments :—			
India 3¼ per Cent. ....	78	3 0	
London & North Western Railway Consolidated 4 per Cent. Pref. Stock .....	72	16 0	
London & South Western Railway Consolidated 4 per Cent. Pref. Stock .....	86	13 4	
Canada 3½ per Cent. Registered Stock .....	74	7 5	
			311 19 9
Income Tax returned .....			115 9 11
Grant returned—' Caird Fund,' Zoological Station at Naples .....			100 0 0

*Investments.*

	Nominal Amount.	
	£ s. d.	
£5,701 10 5		
<i>Less</i> Converted into		
War Loan 4½ per		
Cent. Stock—		
1,050 0 0		
	4,651 10 5	Consolidated 2½ per Cent. Stock
	3,600 0 0	India 3 per Cent. Stock
	879 4 9	£43 Great Indian Peninsula Railway ' B ' Annuity
	2,627 0 10	India 3½ per Cent. Stock, ' Caird Fund '
	2,100 0 0	London and North Western Railway Consolidated
		4 per Cent. Preference Stock, ' Caird Fund '
	2,500 0 0	Canada 3½ (1930-50) Registered Stock, ' Caird Fund '
	2,500 0 0	London and South Western Railway Consolidated
		4 per Cent. Preference Stock, ' Caird Fund '
	84 12 0	Sir Frederick Bramwell's Gift of 2½ per Cent. Self
		Cumulating Consolidated Stock
	1,450 0 0	War Loan 4½ per Cent. 1925/45
	700 0 0	" " " (resulting from
		conversion of £1,050 2½ per Cent. Consols)
	1,000 0 0	Lloyds Bank, Birmingham—Deposit Account in-
		cluded in Balance at Bank, Sir J. Caird's Gift
		for Radio-Activity Investigation
	<u>£22,092 8 0</u>	
		<u>£8,051 9 0</u>

JOHN PERRY, *General Treasurer.*

WITH THE BRITISH ASSOCIATION FOR THE  
July 1, 1915, to June 30, 1916.

Cr.

## PAYMENTS.

	£	s.	d.	
By Rent and Office Expenses .....	100	15	11	
Salaries, &c. ....	729	2	7	
Printing, Binding, &c. ....	1,386	8	7	
Expenses of Manchester Meeting .....	144	19	2	
Grants to Research Committees ;—				
	£	s.	d.	
Seismological Investigations .....	130	0	0	
Tables of Constants .....	40	0	0	
Mathematical Tables .....	35	0	0	
Dynamic Isomerism .....	20	0	0	
Non-Aromatic Diazonium Salts .....	8	10	0	
Old Red Sandstone Rock of Kiltoran .....	7	0	0	
Old Red Sandstone Rock of Rhynie .....	25	0	0	
Belmullet Whaling Station .....	25	0	0	
Fatigue from Economic Standpoint .....	20	0	0	
Industrial Unrest.....	20	0	0	
Women in Industry.....	90	0	0	
Effect of War on Credit .....	25	0	0	
Stress Distributions.....	40	0	0	
Engineering Problems affecting the Prosperity of the Country .....	10	0	0	
Physical Characters of Ancient Egyptians .....	12	8	1	
Paleolithic Site in Jersey.....	25	0	0	
Distribution of Bronze Age Implements .....	3	5	9	
Ductless Glands (1914) .....	35	0	0	
(1915) .....	14	0	0	
Physiology of Heredity .....	45	0	0	
Renting of Cinchona Station .....	12	10	0	
Mental and Physical Factors involved in Education.....	20	0	0	
School Books and Eyesight .....	3	5	0	
Museums.....	15	0	0	
Free Place System .....	10	0	0	
Corresponding Societies Committee .....	25	0	0	
		715	18	10
Grants made from 'Caird Fund' .....	270	0	0	
Purchase of £1,450 War Loan $4\frac{1}{2}$ per Cent. 1925/45 .....	1,442	3	7	
Balance at Lloyds Bank, Birmingham (with accrued Interest) including Sir James Caird's Gift, Radio-Activity Investigation, of £1,000 and accrued Interest thereon £72 15s. 0d. ....	1,769	13	0	
Balance at Williams Deacon's Bank (with Interest accrued) .....	1,145	18	5	
Balance at Bank of England—Western Branch :—				
On 'Caird Fund' .....	290	7	10	
On General Account .....	56	1	1	
		346	8	11
			3,262	0
				4

£8,051 9 0

I have examined the above Account with the Books and Vouchers of the Association, and certify the same to be correct. I have also verified the Balances at the Bankers, and have ascertained that the Investments are registered in the names of the Trustees, except £50 Investment in the War Loan  $4\frac{1}{2}$  per Cent. Stock which stands in the name of the Treasurer.

W. B. KEEN, Chartered Accountant.  
August 22, 1916.

APPROVED—  
EDWARD BRABROOK, } Auditors.  
EVERARD IM THURN, }

1916.

ATTENDANCES AND RECEIPTS.

Table showing the Attendances and Receipts

Date of Meeting	Where held	Presidents	Old Life Members	New Life Members
1831, Sept. 27	York	Viscount Milton, D.O.L., F.R.S.	—	—
1832, June 19	Oxford	The Rev. W. Buckland, F.R.S.	—	—
1833, June 25	Cambridge	The Rev. A. Sedgwick, F.R.S.	—	—
1834, Sept. 8	Edinburgh	Sir T. M. Brisbane, D.O.L., F.R.S.	—	—
1835, Aug. 10	Dublin	The Rev. Provost Lloyd, LL.D., F.R.S.	—	—
1836, Aug. 22	Bristol	The Marquis of Lansdowne, F.R.S.	—	—
1837, Sept. 11	Liverpool	The Earl of Burlington, F.R.S.	—	—
1838, Aug. 10	Newcastle-on-Tyne.	The Duke of Northumberland, F.R.S.	—	—
1839, Aug. 26	Birmingham	The Rev. W. Vernon Harcourt, F.R.S.	—	—
1840, Sept. 17	Glasgow	The Marquis of Breadalbane, F.R.S.	—	—
1841, July 20	Plymouth	The Rev. W. Whewell, F.R.S.	169	65
1842, June 23	Manchester	The Lord Francis Egerton, F.G.S.	303	169
1843, Aug. 17	Cork	The Earl of Rosse, F.R.S.	109	28
1844, Sept. 26	York	The Rev. G. Peacock, D.D., F.R.S.	226	150
1845, June 19	Cambridge	Sir John F. W. Herschel, Bart., F.R.S.	313	36
1846, Sept. 10	Southampton	Sir Roderick I. Murchison, Bart., F.R.S.	241	10
1847, June 23	Oxford	Sir Robert H. Inglis, Bart., F.R.S.	314	18
1848, Aug. 9	Swansea	The Marquis of Northampton, Pres. F.R.S.	149	3
1849, Sept. 12	Birmingham	The Rev. T. R. Robinson, D.D., F.R.S.	227	12
1850, July 21	Edinburgh	Sir David Brewster, K.H., F.R.S.	235	9
1851, July 2	Ipswich	G. B. Airy, Astronomer Royal, F.R.S.	172	8
1852, Sept. 1	Belfast	Lieut.-General Sabine, F.R.S.	164	10
1853, Sept. 3	Hull	William Hopkins, F.R.S.	141	13
1854, Sept. 20	Liverpool	The Earl of Harrowby, F.R.S.	238	23
1855, Sept. 12	Glasgow	The Duke of Argyll, F.R.S.	194	33
1856, Aug. 6	Cheltenham	Prof. C. G. B. Daubeny, M.D., F.R.S.	182	14
1857, Aug. 26	Dublin	The Rev. H. Lloyd, D.D., F.R.S.	236	15
1858, Sept. 22	Leeds	Richard Owen, M.D., D.O.L., F.R.S.	222	42
1859, Sept. 14	Aberdeen	H.R.H. The Prince Consort	184	27
1860, June 27	Oxford	The Lord Wrottesley, M.A., F.R.S.	286	21
1861, Sept. 4	Manchester	William Fairbairn, LL.D., F.R.S.	321	113
1862, Oct. 1	Cambridge	The Rev. Professor Willis, M.A., F.R.S.	239	15
1863, Aug. 26	Newcastle-on-Tyne.	Sir William G. Armstrong, C.B., F.R.S.	203	36
1864, Sept. 13	Bath	Sir Charles Lyell, Bart., M.A., F.R.S.	287	40
1865, Sept. 6	Birmingham	Prof. J. Phillips, M.A., LL.D., F.R.S.	292	44
1866, Aug. 22	Nottingham	William R. Grove, Q.C., F.R.S.	207	31
1867, Sept. 4	Dundee	The Duke of Buccleuch, K.C.B., F.R.S.	167	25
1868, Aug. 19	Norwich	Dr. Joseph D. Hooker, F.R.S.	196	18
1869, Aug. 18	Exeter	Prof. G. G. Stokes, D.O.L., F.R.S.	204	21
1870, Sept. 14	Liverpool	Prof. T. H. Huxley, LL.D., F.R.S.	314	39
1871, Aug. 2	Edinburgh	Prof. Sir W. Thomson, LL.D., F.R.S.	246	28
1872, Aug. 14	Brighton	Dr. W. B. Carpenter, F.R.S.	245	36
1873, Sept. 17	Bradford	Prof. A. W. Williamson, F.R.S.	212	27
1874, Aug. 19	Belfast	Prof. J. Tyndall, LL.D., F.R.S.	162	13
1875, Aug. 25	Bristol	Sir John Hawkshaw, F.R.S.	239	36
1876, Sept. 6	Glasgow	Prof. T. Andrews, M.D., F.R.S.	221	35
1877, Aug. 15	Plymouth	Prof. A. Thomson, M.D., F.R.S.	173	19
1878, Aug. 14	Dublin	W. Spottiswoode, M.A., F.R.S.	201	18
1879, Aug. 20	Sheffield	Prof. G. J. Allman, M.D., F.R.S.	184	16
1880, Aug. 25	Swansea	A. C. Ramsay, LL.D., F.R.S.	144	11
1881, Aug. 31	York	Sir John Lubbock, Bart., F.R.S.	272	28
1882, Aug. 23	Southampton	Dr. C. W. Siemens, F.R.S.	178	17
1883, Sept. 19	Southport	Prof. A. Cayley, D.O.L., F.R.S.	203	60
1884, Aug. 27	Montreal	Prof. Lord Rayleigh, F.R.S.	235	20
1886, Sept. 9	Aberdeen	Sir Lyon Playfair, K.O.B., F.R.S.	225	18
1886, Sept. 1	Birmingham	Sir J. W. Dawson, C.M.G., F.R.S.	314	25
1887, Aug. 31	Manchester	Sir H. E. Roscoe, D.O.L., F.R.S.	428	86
1888, Sept. 5	Bath	Sir F. J. Bramwell, F.R.S.	266	36
1889, Sept. 11	Newcastle-on-Tyne.	Prof. W. H. Flower, C.B., F.R.S.	277	20
1890, Sept. 3	Leeds	Sir F. A. Abel, C.B., F.R.S.	259	21
1891, Aug. 19	Cardiff	Dr. W. Huggins, F.R.S.	189	24
1892, Aug. 3	Edinburgh	Sir A. Geikie, LL.D., F.R.S.	280	14
1893, Sept. 13	Nottingham	Prof. J. S. Burdon Sanderson, F.R.S.	201	17
1894, Aug. 8	Oxford	The Marquis of Salisbury, K.G., F.R.S.	327	21
1895, Sept. 11	Ipswich	Sir Douglas Galton, K.C.B., F.R.S.	214	13
1896, Sept. 16	Liverpool	Sir Joseph Lister, Bart., Pres. R.S.	330	31
1897, Aug. 18	Toronto	Sir John Evans, K.C.B., F.R.S.	120	8
1898, Sept. 7	Bristol	Sir W. Crookes, F.R.S.	281	19
1899, Sept. 13	Dover	Sir Michael Foster, K.C.B., Sec. R.S.	296	20
1900, Sept. 5	Bradford	Sir William Turner, D.O.L., F.R.S.	267	13

\* Ladies were not admitted by purchased tickets until 1843. † Tickets of Admission to Sections only.

[Continued on p. lii.]



## at Annual Meetings of the Association.

Old Annual Members	New Annual Members	Associates	Ladies	Foreigners	Total	Amount received during the Meeting	Sums paid on account of Grants for Purposes	Year
—	—	—	—	—	353	—	—	1831
—	—	—	—	—	—	—	—	1832
—	—	—	—	—	900	—	—	1833
—	—	—	—	—	1298	—	£20 0 0	1834
—	—	—	—	—	—	—	167 0 0	1835
—	—	—	—	—	1350	—	435 0 0	1836
—	—	—	—	—	1840	—	922 12 6	1837
—	—	—	—	—	2400	—	932 2 2	1838
—	—	—	1100*	—	1438	—	1595 11 0	1839
—	—	—	—	34	1353	—	1546 16 4	1840
46	317	—	60*	—	891	—	1235 10 11	1841
75	376	33†	331*	28	1315	—	1449 17 8	1842
71	185	—	160	—	—	—	1565 10 2	1843
45	190	—	260	—	—	—	981 12 8	1844
94	22	407	172	35	1079	—	831 9 9	1845
65	39	270	196	36	857	—	685 16 0	1846
197	40	495	203	53	1320	—	208 5 4	1847
54	25	376	197	15	819	£707 0 0	275 1 8	1848
93	33	447	237	22	1071	963 0 0	159 19 6	1849
128	42	510	273	44	1241	1085 0 0	345 18 0	1850
61	47	244	141	37	710	620 0 0	391 9 7	1851
63	60	510	292	9	1108	1085 0 0	304 6 7	1852
56	57	367	236	6	876	903 0 0	205 0 0	1853
121	121	765	524	10	1802	1882 0 0	380 19 7	1854
142	101	1094	543	26	2133	2311 0 0	480 16 4	1855
104	48	412	346	9	1115	1098 0 0	734 13 9	1856
156	120	900	569	26	2022	2015 0 0	507 15 4	1857
111	91	710	509	13	1698	1931 0 0	618 18 2	1858
125	179	1206	821	22	2564	2782 0 0	684 11 1	1859
177	59	636	463	47	1689	1604 0 0	766 19 6	1860
184	125	1589	791	15	3138	3944 0 0	1111 5 10	1861
160	57	433	242	25	1161	1089 0 0	1293 16 6	1862
154	209	1704	1004	25	3335	3640 0 0	1608 3 10	1863
182	103	1119	1058	13	2802	2965 0 0	1289 15 8	1864
215	149	766	508	23	1997	2227 0 0	1591 7 10	1865
218	105	960	771	11	2303	2469 0 0	1750 13 4	1866
193	118	1163	771	7	2444	2613 0 0	1739 4 0	1867
226	117	720	682	45‡	2004	2042 0 0	1940 0 0	1868
229	107	678	600	17	1856	1931 0 0	1622 0 0	1869
303	195	1103	910	14	2878	3096 0 0	1572 0 0	1870
311	127	976	754	21	2463	2575 0 0	1472 2 6	1871
280	80	937	912	43	2533	2649 0 0	1285 0 0	1872
237	99	796	601	11	1983	2120 0 0	1685 0 0	1873
232	85	817	630	12	1951	1979 0 0	1151 16 0	1874
307	93	884	672	17	2248	2397 0 0	960 0 0	1875
331	185	1265	712	25	2774	3023 0 0	1092 4 2	1876
238	59	446	283	11	1229	1268 0 0	1128 9 7	1877
290	93	1285	674	17	2578	2615 0 0	725 16 6	1878
239	74	529	349	13	1404	1425 0 0	1080 11 11	1879
171	41	389	147	12	915	899 0 0	731 7 7	1880
313	176	1230	514	24	2557	2689 0 0	476 8 1	1881
253	79	516	189	21	1253	1286 0 0	1126 1 11	1882
330	323	952	841	5	2714	3369 0 0	1083 3 3	1883
317	219	826	74	26 & 60 H.‡	1777	1855 0 0	1173 4 0	1884
322	122	1053	447	6	2203	2256 0 0	1385 0 0	1885
438	179	1067	429	11	2453	2532 0 0	995 0 6	1886
510	244	1985	493	92	3838	4336 0 0	1186 18 0	1887
399	100	639	509	12	1984	2107 0 0	1511 0 5	1888
412	113	1024	579	21	2437	2441 0 0	1417 0 11	1889
368	92	680	334	12	1775	1776 0 0	789 16 8	1890
341	152	672	107	35	1497	1664 0 0	1029 10 0	1891
413	141	733	439	50	2070	2007 0 0	864 10 0	1892
328	57	773	268	17	1661	1653 0 0	907 15 6	1893
435	69	941	451	77	2321	2175 0 0	583 15 6	1894
290	31	493	261	22	1324	1236 0 0	977 15 6	1895
383	139	1384	873	41	3181	3228 0 0	1104 6 1	1896
286	125	682	100	41	1362	1398 0 0	1059 10 8	1897
327	96	1051	639	33	2446	2399 0 0	1212 0 0	1898
324	68	548	120	27	1403	1328 0 0	1430 14 2	1899
297	45	801	482	9	1915	1801 0 0	1072 10 0	1900

† Including Ladies. ‡ Fellows of the American Association were admitted as Hon. Members for this Meeting.

Continued on p. liii.

Table showing the Attendances and Receipts

Date of Meeting	Where held	Presidents	Old Life Members	New Life Members
1901, Sept. 11	Glasgow	Prof. A. W. Rücker, D.Sc., Sec.R.S.	310	37
1902, Sept. 10	Belfast	Prof. J. Dewar, LL.D., F.R.S.	243	21
1903, Sept. 9	Southport	Sir Norman Lockyer, K.C.B., F.R.S.	250	21
1904, Aug. 17	Cambridge	Rt. Hon. A. J. Balfour, M.P., F.R.S.	419	32
1905, Aug. 15	South Africa	Prof. G. H. Darwin, LL.D., F.R.S.	115	40
1906, Aug. 1	York	Prof. E. Ray Lankester, LL.D., F.R.S.	322	10
1907, July 31	Leicester	Sir David Gill, K.C.B., F.R.S.	276	19
1908, Sept. 2	Dublin	Dr. Francis Darwin, F.R.S.	294	24
1909, Aug. 25	Winnipeg	Prof. Sir J. J. Thomson, F.R.S.	117	13
1910, Aug. 31	Sheffield	Rev. Prof. T. G. Bonney, F.R.S.	293	26
1911, Aug. 30	Portsmouth	Prof. Sir W. Ramsay, K.C.B., F.R.S.	284	21
1912, Sept. 4	Dundee	Prof. E. A. Schäfer, F.R.S.	288	14
1913, Sept. 10	Birmingham	Sir Oliver J. Lodge, F.R.S.	376	40
1914, July-Sept.	Australia	Prof. W. Bateson, F.R.S.	172	13
1915, Sept. 7	Manchester	Prof. A. Schuster, F.R.S.	242	19
1916, Sept. 5	Newcastle-on-Tyne	Sir Arthur Evans, F.R.S.	164	12

¶ Including 848 Members of the South African Association.

‡‡ Grants from the Caird Fund are not included in this and subsequent sums.

## ANALYSIS OF ATTENDANCES AT

[The total attendances for the years 1832,

Average attendance at 79 Meetings : 1858.

	Average Attendance
Average attendance at 5 Meetings beginning during <i>June</i> , between 1833 and 1860	1260
Average attendance at 4 Meetings beginning during <i>July</i> , between 1841 and 1907	1122
Average attendance at 32 Meetings beginning during <i>August</i> , between 1836 and 1911	1927
Average attendance at 37 Meetings beginning during <i>September</i> , between 1831 and 1913	1977
Attendance at 1 Meeting held in <i>October</i> , Cambridge, 1862.	1161

Meetings beginning during August.

Average attendance at—

4 Meetings beginning during the 1st week in <i>August</i> ( 1st- 7th)	1905
5 " " " " 2nd " " " ( 8th-14th)	2130
9 " " " " 3rd " " " ( 15th-21st)	1802
14 " " " " 4th " " " ( 22nd-31st)	1935

## at Annual Meetings of the Association—(continued).

Old Annual Members	New Annual Members	Associates	Ladies	Foreigners	Total	Amount received during the Meeting	Sums paid on account of Grants for Scientific Purposes	Year
374	131	794	246	20	1912	£2046 0 0	£920 9 11	1901
314	86	647	305	6	1620	1644 0 0	947 0 0	1902
319	90	688	365	21	1754	1762 0 0	845 13 2	1903
449	113	1338	317	121	2799	2650 0 0	887 18 11	1904
937¶	411	430	181	16	2130	2422 0 0	928 2 2	1905
356	93	817	352	22	1972	1811 0 0	882 0 9	1906
339	61	659	251	42	1647	1561 0 0	757 12 10	1907
465	112	1166	222	14	2297	2317 0 0	1157 18 8	1908
290**	162	789	90	7	1468	1623 0 0	1014 9 9	1909
379	57	563	123	8	1449	1439 0 0	963 17 0	1910
349	61	414	81	31	1241	1176 0 0	922 0 0	1911
368	95	1292	359	88	2504	2349 0 0	845 7 6	1912
480	149	1287	291	20	2643	2756 0 0	978 17 11½	1913
139	4160¶	539¶	—	21	5044¶	4873 0 0	1086 16 4	1914
287	116	628*	141	8	1441	1406 0 0	1159 2 8	1915
250	76	251*	73	—	826	821 0 0	715 18 10	1916

\*\* Including 137 Members of the American Association.

¶ Special arrangements were made for Members and Associates joining locally in Australia, see Report, 1914, p. 686. The numbers include 80 Members who joined in order to attend the Meeting of L'Association Française at Le Havre.

\* Including Student's Tickets, 10s.

## THE ANNUAL MEETINGS, 1831-1913.

1835, 1843, and 1844 are unknown.]

*Meetings beginning during September.*

Average attendance at—

	Average Attendance
13 Meetings beginning during the 1st week in <i>September</i> (1st-7th).	2131
17 " " " " 2nd " " " (8th-14th).	1906
5 " " " " 3rd " " " (15th-21st).	2206
2 " " " " 4th " " " (22nd-30th).	1025

*Meetings beginning during June, July, and October.*

Attendance at 1 Meeting (1845, June 19) beginning during the 3rd week in <i>June</i> (15th-21st).	1079
Average attendance at 4 Meetings beginning during the 4th week in <i>June</i> (22nd-30th).	1306
Attendance at 1 Meeting (1851, July 2) beginning during the 1st week in <i>July</i> (1st-7th).	710
Average attendance at 2 Meetings beginning during the 3rd week in <i>July</i> (15th-21st).	1066
Attendance at 1 Meeting (1907, July 31) beginning during the 5th week in <i>July</i> (29th-31st).	1647
Attendance at 1 Meeting (1862, October 1) beginning during the 1st week in <i>October</i> (1st-7th).	1161

## LIST OF GRANTS: NEWCASTLE-UPON-TYNE, 1916.

RESEARCH COMMITTEES, ETC., APPOINTED BY THE GENERAL COMMITTEE  
AT THE NEWCASTLE MEETING: SEPTEMBER, 1916.

(NOTE.—The *personnel* of Committees is subject to amendment.)

1. *Receiving Grants of Money.*

Subject for Investigation, or Purpose	Members of Committee	Grants
<b>SECTION A.—MATHEMATICS AND PHYSICS.</b>		
Seismological Observations.	<i>Chairman.</i> —Professor H. H. Turner. <i>Secretary.</i> —Mr. J. J. Shaw. Mr. C. Vernon Boys, Dr. J. E. Crombie, Mr. Horace Darwin, Dr. C. Davison, Sir F. W. Dyson, Dr. R. T. Glazebrook, Professors C. G. Knott and H. Lamb, Sir J. Larmor, Professors A. E. H. Love, H. M. Macdonald, J. Perry, and H. C. Plummer, Mr. W. E. Plummer, Professors R. A. Sampson and A. Schuster, Sir Napier Shaw, Dr. G. T. Walker, and Mr. G. W. Walker.	£ s. d. 100 0 0
Annual Tables of Constants and Numerical Data, chemical, physical, and technological.	<i>Chairman.</i> —Sir E. Rutherford. <i>Secretary.</i> —Dr. W. C. McC. Lewis.	40 0 0
Calculation of Mathematical Tables.	<i>Chairman.</i> —Professor M. J. M. Hill. <i>Secretary.</i> —Professor J. W. Nicholson. Mr. J. R. Airey, Mr. T. W. Chaundy, Professor L. N. G. Filon, Sir G. Greenhill, Professor E. W. Hobson, Mr. G. Kennedy, and Professors Alfred Lodge, A. E. H. Love, H. M. Macdonald, G. D. Matthews, G. N. Watson, and A. G. Webster.	20 0 0
Determination of Gravity at Sea.	<i>Chairman.</i> —Professor A. E. Love. <i>Secretary.</i> —Professor W. G. Duffield. Mr. T. W. Chaundy and Professors A. S. Eddington, A. Schuster, and H. H. Turner.	10 0 0

1. *Receiving Grants of Money*—continued.

Subject for Investigation, or Purpose	Members of Committee	Grants
<b>SECTION B.—CHEMISTRY.</b>		
Dynamic Isomerism.	<i>Chairman.</i> —Professor H. E. Armstrong. <i>Secretary.</i> —Dr. T. M. Lowry. Dr. Desch, Sir J. J. Dobbie, Dr. M. O. Forster, and Professor Sydney Young.	£ s. d. 15 0 0
To report on the Botanical and Chemical Characters of the Eucalypts and their Correlation.	<i>Chairman.</i> —Professor H. E. Armstrong. <i>Secretary.</i> —Mr. H. G. Smith. Dr. Andrews, Mr. R. T. Baker, Professor F. O. Bower, Mr. R. H. Cabbage, Professor A. J. Ewart, Professor C. E. Fawsitt, Dr. Heber Green, Dr. Cuthbert Hall, Professors Orme Masson, Rennie, and Robinson, and Mr. St. John.	30 0 0
Absorption Spectra and Chemical Constitution of Organic Compounds.	<i>Chairman.</i> —Sir J. J. Dobbie. <i>Secretary.</i> —Mr. E. E. C. Baly. Mr. A. W. Stewart.	10 0 0
<b>SECTION C.—GEOLOGY.</b>		
The Old Red Sandstone Rocks of Kiltorcan, Ireland.	<i>Chairman.</i> —Professor Grenville Cole. <i>Secretary.</i> —Professor T. Johnson. Dr. J. W. Evans, Dr. R. Kidston, and Dr. A. Smith Woodward.	4 0 0
To excavate Critical Sections in the Palæozoic Rocks of England and Wales.	<i>Chairman.</i> —Professor W. W. Watts. <i>Secretary.</i> —Professor W. G. Fearnside. Professor W. S. Boulton, Mr. E. S. Cobbold, Professor E. J. Garwood, Mr. V. C. Illing, Dr. Lapworth, and Dr. J. E. Marr.	20 0 0
<b>SECTION D.—ZOOLOGY.</b>		
An investigation of the Biology of the Abrolhos Islands and the North-west Coast of Australia (north of Shark's Bay to Broome), with particular reference to the Marine Fauna.	<i>Chairman.</i> —Professor W. A. Herdman. <i>Secretary.</i> —Professor W. J. Dakin. Dr. J. H. Ashworth and Professor F. O. Bower.	6 0 0
Experiments in Inheritance in Silkworms.	<i>Chairman.</i> —Professor W. Bateson. <i>Secretary.</i> —Mrs. Merritt Hawkes. Dr. F. A. Dixey and Dr. L. Doncaster.	20 0 0

1. *Receiving Grants of Money*—continued.

Subject for Investigation, or Purpose	Members of Committee	Grants
<b>SECTION F.—ECONOMIC SCIENCE AND STATISTICS.</b>		
The question of Fatigue from the Economic Standpoint, if possible in co-operation with Section I, Sub-section of Psychology.	<i>Chairman.</i> —Professor Muirhead. <i>Secretary.</i> —Miss B. L. Hutchins. Miss A. M. Anderson, Mr. Cyril Burt, Mr. E. Cadbury, Dr. E. L. Collis, Mr. P. Sargant Florence, Captain Greenwood, Professors Stanley Kent and Loveday, Miss M. C. Matheson, Dr. C. S. Myers, Mr. C. K. Ogden, Miss M. Smith, and Dr. Vernon.	£ s. d. 40 0 0
Replacement of Men by Women in Industry.	<i>Chairman.</i> —Professor W. R. Scott. <i>Secretary.</i> — Miss Ashley, Ven. Archdeacon Cunningham, Professors E. C. K. Gonner and Hallsworth, Professor J. C. Kydd, Mr. J. E. Highton, Professor A. W. Kirkaldy, Miss Mellor, and Miss Stephens.	20 0 0
The Effects of the War on Credit, Currency, and Finance.	<i>Chairman.</i> —Professor W. R. Scott. <i>Secretary.</i> —Mr. J. E. Allen. Professor C. F. Bastable, Sir E. Brabrook, Professor Dicksee, Mr. B. Ellinger, Mr. A. H. Gibson, Professor E. C. K. Gonner, Mr. F. W. Hirst, Professor A. W. Kirkaldy, Mr. D. M. Mason, Sir R. H. Inglis Palgrave, and Mr. E. Sykes.	10 0 0
<b>SECTION G.—ENGINEERING.</b>		
To report on certain of the more complex Stress Distributions in Engineering Materials.	<i>Chairman.</i> —Professor J. Perry. <i>Secretaries.</i> — Professors E. G. Coker and J. E. Petavel. Professor A. Barr, Dr. Chas. Chree, Mr. Gilbert Cook, Professor W. E. Dalby, Sir J. A. Ewing, Professor L. N. G. Filon, Messrs. A. R. Fulton and J. J. Guest, Professors J. B. Henderson, F. C. Lea, and A. E. H. Love, Dr. W. Mason, Dr. F. Rogers, Mr. W. A. Scoble, Dr. T. E. Stanton, Mr. C. E. Stromeyer, and Mr. J. S. Wilson.	40 0 0

1. *Receiving Grants of Money*—continued.

Subject for Investigation, or Purpose	Members of Committee	Grants
<b>SECTION H.—ANTHROPOLOGY.</b>		
To investigate the Physical Characters of the Ancient Egyptians.	<i>Chairman.</i> —Professor G. Elliot Smith. <i>Secretary.</i> —Dr. F. C. Shruballs, Dr. F. Wood-Jones, Professor A. Keith, and Dr. C. G. Seligman.	£ s. d. 2 11 11
To excavate a Palæolithic Site in Jersey.	<i>Chairman.</i> —Dr. R. R. Marett. <i>Secretary.</i> —Mr. G. de Gruchy, Dr. C. W. Andrews, Mr. H. Balfour, Professor A. Keith, and Colonel Warton.	30 0 0
To conduct Archæological Investigations in Malta.	<i>Chairman.</i> —Professor J. L. Myres. <i>Secretary.</i> —Dr. T. Ashby, Mr. H. Balfour, Dr. A. C. Haddon, and Dr. R. R. Marett.	20 0 0
To report on the Distribution of Bronze Age Implements.	<i>Chairman.</i> —Professor J. L. Myres. <i>Secretary.</i> —Mr. H. Peake, Professor W. Ridgeway, Mr. H. Balfour, Sir C. H. Read; Professor W. Boyd Dawkins, Dr. R. R. Marett, and Mr. O. G. S. Crawford.	1 14 3
To investigate and ascertain the Distribution of Artificial Islands in the lochs of the Highlands of Scotland.	<i>Chairman.</i> —Professor Boyd Dawkins. <i>Secretary.</i> —Prof. J. L. Myres, Professors T. H. Bryce and W. Ridgeway, Mr. H. Fraser, Dr. A. Low, and Mr. A. J. B. Wace.	5 0 0
<b>SECTION I.—PHYSIOLOGY.</b>		
The Ductless Glands.	<i>Chairman.</i> —Sir E. A. Schäfer. <i>Secretary.</i> —Professor Swale Vincent, Dr. A. T. Cameron and Professor A. B. Macallum.	15 0 0
Psychological War-research.—(i) Mental Tests of Industrial Fatigue; (ii) Mental Factors in Alcoholism; (iii) Evidence and Rumour; (iv) Efficacy of Thrift Posters; (v) Other Problems.	<i>Chairman.</i> — <i>Secretary.</i> —Mr. Cyril Burt, Dr. Jessie Murray and Miss May Smith.	10 0 0
<b>SECTION K.—BOTANY.</b>		
Experimental Studies in the Physiology of Heredity.	<i>Chairman.</i> —Professor F. F. Blackman. <i>Secretary.</i> —Mr. R. P. Gregory, Professors Bateson and Keeble and Miss E. R. Saunders.	45 0 0

1. *Receiving Grants of Money*—continued.

Subject for Investigation, or Purpose	Members of Committee	Grants
To consider the possibilities of investigation of the Ecology of Fungi, and assist Mr. J. Ramsbottom in his initial efforts in this direction.	<p><i>Chairman.</i>—Mr. H. W. T. Wager.  <i>Secretary.</i>—Mr. J. Ramsbottom.            Mr. W. B. Brierley, Mr. F. T. Brooks, Mr. W. Cheesman, Professor T. Johnson, Dr. C. E. Moss, Professor M. C. Potter, Mr. L. Carlton Rea, Miss A. Lorrain Smith, and Mr. Swanstone.</p>	<p>£ s. d.            8 0 0</p>
<b>SECTION L.—EDUCATIONAL SCIENCE.</b>		
To inquire into and report upon the methods and results of research into the Mental and Physical Factors involved in Education.	<p><i>Chairman.</i>—Dr. C. S. Myers.  <i>Secretary.</i>—Professor J. A. Green.            Professor J. Adams, Dr. G. A. Auden, Sir E. Brabrook, Dr. W. Brown, Mr. C. Burt, Professor E. P. Culverwell, Mr. G. F. Daniell, Miss B. Foxley, Professor R. A. Gregory, Dr. C. W. Kimmins, Professor W. McDougall, Professor T. P. Nunn, Dr. W. H. R. Rivers, Dr. F. C. Shrubbsall, Professor H. Bompas Smith, Dr. C. Spearman, and Mr. A. E. Twentyman.</p>	10 0 0
The Influence of School Books upon Eyesight.	<p><i>Chairman.</i>—Dr. G. A. Auden.  <i>Secretary.</i>—Mr. G. F. Daniell.            Mr. C. H. Bothamley, Mr. W. D. Eggar, Professor R. A. Gregory, Dr. N. Bishop Harman, Mr. J. L. Holland, Dr. W. E. Sumpner, Mr. A. P. Trotter, and Mr. Trevor Walsh.</p>	5 0 0
To examine, inquire into, and report on the Character, Work, and Maintenance of Museums, with a view to their Organisation and Development as Institutions for Education and Research; and especially to inquire into the Requirements of Schools.	<p><i>Chairman.</i>—Professor J. A. Green.  <i>Secretaries.</i>—Mr. H. Bolton and Dr. J. A. Clubb.            Dr. F. A. Bather, Mr. C. A. Buckmaster, Mr. M. D. Hill, Dr. W. E. Hoyle, Professors E. J. Garwood and P. Newberry, Sir H. Miers, Sir Richard Temple, Mr. H. Hamshaw Thomas, Professor F. E. Weiss, Mrs. J. White, Rev. H. Browne, Drs. A. C. Haddon and H. S. Harrison, Mr. Herbert R. Rathbone, and Dr. W. M. Tattersall.</p>	15 0 0



1. *Receiving Grants of Money*—continued.

Subject for Investigation, or Purpose	Members of Committee	Grants
The Effects of the 'Free-place' System upon Secondary Education.	<p><i>Chairman.</i>—Mr. C. A. Buckmaster.  <i>Secretary.</i>—Mr. D. Berridge.            Mr. C. H. Bothamley, Miss L. J. Clarke, Miss B. Foxley, Dr. W. Garnett, Professor R. A. Gregory, Mr. J. L. Paton, Professor H. Bompas Smith, Dr. H. Lloyd Snape, and Miss Walter.</p>	<p>£ s. d.            15 0 0</p>
To consider and report upon the method and substance of Science Teaching in Secondary Schools, with particular reference to its essential place in general Education.	<p><i>Chairman.</i>—Professor R. A. Gregory.  <i>Secretary.</i>—Dr. E. H. Tripp.            Mr. D. Berridge, Mr. C. A. Buckmaster, Miss L. J. Clarke, Mr. G. F. Daniell, Mr. Cary Gilson, Miss C. L. Laurie, Professor T. P. Nunn, and Professor A. M. Worthington.</p>	<p>10 0 0</p>
<b>CORRESPONDING SOCIETIES.</b>		
Corresponding Societies Committee for the preparation of their Report.	<p><i>Chairman.</i>—Mr. W. Whitaker.  <i>Secretary.</i>—Mr. W. Mark Webb.            Rev. J. O. Bevan, Sir Edward Brabrook, Sir H. G. Fordham, Dr. J. G. Garson, Principal E. H. Griffiths, Dr. A. C. Haddon, Mr. T. V. Holmes, Mr. J. Hopkinson, Mr. A. L. Lewis, Mr. T. Sheppard, Rev. T. R. R. Stebbing, and the President and General Officers of the Association.</p>	<p>25 0 0</p>

2. *Not receiving Grants of Money.\**

Subject for Investigation, or Purpose	Members of Committee
<b>SECTION A.—MATHEMATICS AND PHYSICS.</b>	
Investigation of the Upper Atmosphere.	<p><i>Chairman.</i>—Sir Napier Shaw.  <i>Secretary.</i>—            Mr. C. J. P. Cave, Mr. W. H. Dines, Dr. R. T. Glazebrook, Sir J. Larmor, Professors J. E. Petavel and A. Schuster, and Dr. W. Watson.</p>
Radiotelegraphic Investigations.	<p><i>Chairman.</i>—Sir Oliver Lodge.  <i>Secretary.</i>—Dr. W. H. Eccles.            Mr. S. G. Brown, Dr. C. Chree, Sir F. W. Dyson, Professor A. S. Eddington, Dr. Erskine-Murray, Professors J. A. Fleming, G. W. O. Howe, H. M. Macdonald, and J. W. Nicholson, Sir H. Norman, Captain H. R. Sankey, Professor A. Schuster, Sir Napier Shaw, and Professor H. H. Turner.</p>
To aid the work of Establishing a Solar Observatory in Australia.	<p><i>Chairman.</i>—Professor H. H. Turner.  <i>Secretary.</i>—Dr. W. G. Duffield.            Rev. A. L. Cortie, Dr. W. J. S. Lockyer, Mr. F. McClean, and Professor A. Schuster.</p>
To discuss the present needs of Geodesy, including its relation to other branches of Geophysics, and to report to the next meeting of the British Association, with power to present an interim report to the Council if any question of urgency should arise.†	<p><i>Chairman.</i>—Colonel C. F. Close.  <i>Secretary.</i>—Colonel E. H. Hills.            Sir S. G. Burrard, Dr. W. G. Duffield, Sir F. W. Dyson, Mr. A. R. Hinks, Sir T. H. Holdich, Professor A. E. H. Love, Colonel H. G. Lyons, Mr. R. D. Oldham, Professor A. Schuster, Sir Napier Shaw, and Dr. G. W. Walker.</p>
<b>SECTION B.—CHEMISTRY.</b>	
The Transformation of Aromatic Nitroamines and allied substances, and its relation to Substitution in Benzene Derivatives.	<p><i>Chairman.</i>—Professor F. S. Kipping.  <i>Secretary.</i>—Professor K. J. P. Orton.            Dr. J. T. Hewitt and Dr. S. Ruhemann.</p>
The Study of Plant Enzymes, particularly with relation to Oxidation.	<p><i>Chairman.</i>—Mr. A. D. Hall.  <i>Secretary.</i>—Dr. E. F. Armstrong.            Professor H. E. Armstrong, Professor F. Keeble, and Dr. E. J. Russell.</p>
Research on Non-Aromatic Diazonium Salts.	<p><i>Chairman.</i>—Dr. F. D. Chattaway.  <i>Secretary.</i>—Professor G. T. Morgan.            Mr. P. G. W. Bayly and Dr. N. V. Sidgwick.</p>
Chemical Investigation of Natural Plant Products of Victoria.	<p><i>Chairman.</i>—Professor Orme Masson.  <i>Secretary.</i>—Dr. Heber Green.            Mr. J. Cronin and Mr. P. R. H. St. John.</p>

\* Excepting the case of Committees receiving grants from the Caird Fund.

† Joint Committee with Section E.

## 2. Not receiving Grants of Money—continued.

Subject for Investigation, or Purpose	Members of Committee
Fuel Economy; Utilization of Coal; Smoke Prevention.	<p><i>Chairman.</i>—Professor W. A. Bone.  <i>Secretary.</i>—Mr. E. D. Simon.</p> <p>The Rt. Hon. Lord Allerton, Mr. Robert Armitage, Professor J. O. Arnold, Mr. J. A. F. Aspinall, Mr. A. H. Barker, Professor P. P. Bedson, Sir G. T. Beilby, Sir Hugh Bell, Professor W. S. Boulton, Mr. E. Bury, Dr. Charles Carpenter, Dr. Dugald Clerk, Professor H. B. Dixon, Dr. J. T. Dunn, Mr. S. Z. de Ferranti, Dr. William Galloway, Professors W. W. Haldane Gee and Thos. Gray, Mr. T. Y. Greener, Sir Robert Hadfield, Dr. H. S. Hele-Shaw, Dr. D. H. Helps, Dr. G. Hickling, Mr. Grevil Jones, Mr. W. W. Lackie, Mr. Michael Longridge, Dr. J. W. Mellor, Mr. C. H. Merz, Mr. Robert Mond, Mr. Bernard Moore, Hon. Sir Charles Parsons, Sir Richard Redmayne, Professors Ripper and L. T. O'Shea, Mr. E. P. Sloan, Dr. J. E. Stead, Dr. A. Strahan, Mr. C. E. Stromeyer, Mr. Benjamin Talbot, Professor R. Threlfall, Mr. G. Blake Walker, Dr. R. V. Wheeler, Mr. B. W. Winder, Mr. W. B. Woodhouse, Professor W. P. Wynne, and Mr. H. James Yates.</p>
Capillary Chemistry and its Industrial Application.	<p><i>Chairman.</i>—Professor F. G. Donnan.  <i>Secretary.</i>—Professor W. C. McC. Lewis.  Dr. E. F. Armstrong and Dr. S. A. Shorter.</p>
<b>SECTION C.—GEOLOGY.</b>	
To consider the preparation of a List of Characteristic Fossils.	<p><i>Chairman.</i>—Professor P. F. Kendall.  <i>Secretary.</i>—Mr. W. Lower Carter.</p> <p>Professor W. S. Boulton, Professor G. Cole, Dr. A. R. Dwerryhouse, Professors J. W. Gregory, Sir T. H. Holland, G. A. Lebour, and S. H. Reynolds, Dr. Marie C. Stopes, Mr. Cosmo Johns, Dr. J. E. Marr, Professor W. W. Watts, Mr. H. Woods, and Dr. A. Smith Woodward.</p>
To investigate the Flora of Lower Carboniferous times as exemplified at a newly discovered locality at Gullane, Haddingtonshire.	<p><i>Chairman.</i>—Dr. R. Kidston.  <i>Secretary.</i>—Dr. W. T. Gordon.  Dr. J. S. Flett, Professor E. J. Garwood, Dr. J. Horne, and Dr. B. N. Peach.</p>
To excavate Critical Sections in Old Red Sandstone Rocks at Rhynie, Aberdeenshire.	<p><i>Chairman.</i>—Dr. J. Horne.  <i>Secretary.</i>—Dr. W. Mackie.  Drs. J. S. Flett, W. T. Gordon, G. Hickling, R. Kidston, B. N. Peach, and D. M. S. Watson.</p>

2. *Not receiving Grants of Money*—continued.

Subject for Investigation, or Purpose	Members of Committee
The Collection, Preservation, and Systematic Registration of Photographs of Geological Interest.	<p><i>Chairman.</i>—Professor E. J. Garwood.  <i>Secretary.</i>—Professor S. H. Reynolds.            Mr. G. Bingley, Dr. T. G. Bonney, Messrs. C. V. Crook, R. Kidston, and A. S. Reid, Professor W. W. Watts, Messrs. R. Welch and W. Whitaker, and Sir J. J. H. Teall.</p>
To consider the Nomenclature of the Carboniferous, Permo-carboniferous, and Permian Rocks of the Southern Hemisphere.	<p><i>Chairman.</i>—Professor T. W. Edgeworth David.  <i>Secretary.</i>—Professor E. W. Skeats.            Mr. J. W. S. Dun, Sir T. H. Holland, Professors J. W. Gregory and Howchin, Mr. A. E. Kitson, Mr. G. W. Lamplugh, Dr. A. W. Rogers, Professor A. C. Seward, Dr. D. M. S. Watson, and Professor W. G. Woolnough.</p>
To investigate the Geology of Coal-seams.	<p><i>Chairman.</i>—Professor W. S. Boulton.  <i>Secretary.</i>—Dr. W. T. Gordon.            Mr. G. Barrow, Professors Cadman, Grenville Cole, and W. G. Fearnside, Dr. J. S. Flett, Dr. Walcot Gibson, Professors J. W. Gregory and P. F. Kendall, Dr. R. Kidston, Professors G. A. Lebour and T. F. Sibly, Dr. A. Strahan, and Mr. J. R. R. Wilson.</p>
<b>SECTION D.—ZOOLOGY.</b>	
To investigate the Biological Problems incidental to the Belmullet Whaling Station.	<p><i>Chairman.</i>—Dr. A. E. Shipley.  <i>Secretary.</i>—Professor J. Stanley Gardiner.            Mr. R. M. Barrington, Professor W. A. Herdman, Rev. W. Spotswood Green, Mr. E. S. Goodrich, Dr. S. F. Harmer, Dr. E. W. L. Holt, and Professor H. W. Marett Tims.</p>
Nomenclator Animalium Genera et Sub-genera.	<p><i>Chairman.</i>—Dr. P. Chalmers Mitchell.  <i>Secretary.</i>—Rev. T. R. R. Stebbing.            Dr. M. Laurie, Professor Marett Tims, and Dr. A. Smith Woodward.</p>
To obtain, as nearly as possible, a Representative Collection of Marsupials for work upon ( <i>a</i> ) the Reproductive Apparatus and Development, ( <i>b</i> ) the Brain.	<p><i>Chairman.</i>—Professor A. Dendy.  <i>Secretaries.</i>—Professors T. Flynn and G. E. Nicholls.            Professor E. B. Poulton and Professor H. W. Marett Tims.</p>
*To aid competent Investigators selected by the Committee to carry on definite pieces of work at the Zoological Station at Naples.	<p><i>Chairman.</i>—Mr. E. S. Goodrich.  <i>Secretary.</i>—Dr. J. H. Ashworth.            Mr. G. P. Bidder, Professor F. O. Bower, Drs. W. B. Hardy and S. F. Harmer, Professor S. J. Hickson, Sir E. Ray Lankester, Professor W. C. McIntosh, and Dr. A. D. Waller.</p>

\* See note on page 1x.

2. *Not receiving Grants of Money*—continued.

Subject for Investigation, or Purpose	Members of Committee
To summon meetings in London or elsewhere for the consideration of matters affecting the interests of Zoology or Zoologists, and to obtain by correspondence the opinion of Zoologists on matters of a similar kind, with power to raise by subscription from each Zoologist a sum of money for defraying current expenses of the Organisation.	<p><i>Chairman.</i>—Professor S. J. Hickson.  <i>Secretary.</i>—Dr. W. M. Tattersall.  Professors G. C. Bourne, A. Dendy, M. Hartog, W. A. Herdman, and J. Graham Kerr, Dr. P. Chalmers Mitchell, and Professors E. B. Poulton and J. Stanley Gardiner.</p>
To nominate competent Naturalists to perform definite pieces of work at the Marine Laboratory, Plymouth.	<p><i>Chairman and Secretary.</i>—Professor A. Dendy.  Sir E. Ray Lankester, Professor J. P. Hill, and Mr. E. S. Goodrich.</p>
Zoological Bibliography and Publication.	<p><i>Chairman.</i>—Professor E. B. Poulton.  <i>Secretary.</i>—Dr. F. A. Bather.  Mr. E. Heron-Allen, Dr. W. E. Hoyle, and Dr. P. Chalmers Mitchell.</p>

## SECTION E.—GEOGRAPHY.

To aid in the preparation of a Bathymetrical Chart of the Southern Ocean between Australia and Antarctica.

*Chairman.*—Professor T. W. Edgeworth David.  
*Secretary.*—Captain J. K. Davis.  
Professor J. W. Gregory, Sir C. P. Lucas, and Professor Orme Masson.

## SECTION F.—ECONOMIC SCIENCE AND STATISTICS.

Industrial Unrest.

*Chairman.*—Professor A. W. Kirkaldy.  
*Secretary.*—  
Sir H. Bell, Rt. Hon. C. W. Bowerman, Professors S. J. Chapman and E. C. K. Gonner, Mr. H. Gosling, Mr. G. Pickup Holden, Dr. G. B. Hunter, Sir C. W. Macara, and Professor W. R. Scott.

## SECTION G.—ENGINEERING.

To investigate Engineering Problems affecting the future Prosperity of the Country.

*Chairman.*—Dr. H. S. Hele-Shaw.  
*Secretary.*—Professor G. W. O. Howe.  
Professor E. G. Coker, Sir R. Hadfield, Rt. Hon. Sir W. Mather, Mr. W. Maw, and Mr. C. E. Stromeyer.

To consider and report on the Standardization of Impact Tests.

*Chairman.*—Professor W. H. Warren.  
*Secretary.*—Mr. J. Vicars.  
Mr. G. A. Julius, Professor A. H. Gibson, Mr. Houghton, and Professor Payne.

2. *Not receiving Grants of Money*—continued.

Subject for Investigation, or Purpose	Members of Committee
The Investigation of Gaseous Explosions, with special reference to Temperature.	<p><i>Chairman.</i>—Dr. Dugald Clerk.  <i>Secretary.</i>—Professor W. E. Dalby.  Professors W. A. Bone, F. W. Burstall, H. L. Callendar, E. G. Coker, and H. B. Dixon, Drs. R. T. Glazebrook and J. A. Harker, Colonel Sir H. C. L. Holden, Professors B. Hopkinson and J. E. Petavel, Captain H. Riall Sankey, Professor A. Smithells, Professor W. Watson, Mr. D. L. Chapman, and Mr. H. E. Wimperis.</p>
<b>SECTION H.—ANTHROPOLOGY.</b>	
To consider the Collation of Ethnological Literature on Oceania and Africa.	<p><i>Chairman.</i>—Dr. A. C. Haddon.  <i>Secretary.</i>—Dr. C. G. Seligman.  Dr. H. Forbes and Dr. R. R. Marett.</p>
To investigate the Lake Villages in the neighbourhood of Glastonbury in connection with a Committee of the Somerset Archæological and Natural History Society.	<p><i>Chairman.</i>—Professor Boyd Dawkins.  <i>Secretary.</i>—Mr. Willoughby Gardner.  Professor W. Ridgeway, Sir Arthur Evans, Sir C. H. Read, Mr. H. Balfour, Dr. A. Bulleid, and Mr. H. Peake.</p>
To conduct Anthropometric Investigations in the Island of Cyprus.	<p><i>Chairman.</i>—Professor J. L. Myres.  <i>Secretary.</i>—Dr. F. C. Shruballsall.  Dr. A. C. Haddon.</p>
To conduct Explorations with the object of ascertaining the Age of Stone Circles.	<p><i>Chairman.</i>—Sir C. H. Read.  <i>Secretary.</i>—Mr. H. Balfour.  Dr. G. A. Auden, Professor W. Ridgeway, Dr. J. G. Garson, Sir Arthur Evans, Dr. R. Munro, Professors Boyd Dawkins and J. L. Myres, Mr. A. L. Lewis, and Mr. H. Peake.</p>
To prepare and publish Miss Byrne's Gazetteer and Map of the Native Tribes of Australia.	<p><i>Chairman.</i>—Professor Baldwin Spencer.  <i>Secretary.</i>—Dr. R. R. Marett.  Mr. H. Balfour.</p>
The Collection, Preservation, and Systematic Registration of Photographs of Anthropological Interest.	<p><i>Chairman.</i>—Sir C. H. Read.  <i>Secretary.</i>—Dr. Harrison.  Dr. G. A. Auden, Mr. E. Heawood, and Professor J. L. Myres.</p>
To conduct Archæological and Ethnological Researches in Crete.	<p><i>Chairman.</i>—Mr. D. G. Hogarth.  <i>Secretary.</i>—Professor J. L. Myres.  Professor R. C. Bosanquet, Dr. W. L. H. Duckworth, Sir Arthur Evans, Professor W. Ridgeway, and Dr. F. C. Shruballsall.</p>

2. *Not receiving Grants of Money*—continued.

Subject for Investigation, or Purpose	Members of Committee
The Teaching of Anthropology.	<p><i>Chairman.</i>—Sir Richard Temple.  <i>Secretary.</i>—Dr. A. C. Haddon.            Sir E. F. im Thurn, Mr. W. Crooke, Dr. C. G. Seligman, Professor G. Elliot Smith, Dr. R. R. Marett, Professor P. E. Newberry, Dr. G. A. Auden, Professors T. H. Bryce, A. Keith, P. Thompson, R. W. Reid, H. J. Fleure, and J. L. Myres, Sir B. C. A. Windle, and Professors R. J. A. Berry, Baldwin Spencer, Sir T. Anderson Stuart, and E. C. Stirling.</p>
To excavate Early Sites in Macedonia.	<p><i>Chairman.</i>—Professor W. Ridgeway.  <i>Secretary.</i>—Mr. A. J. B. Wace.            Professors R. C. Bosanquet and J. L. Myres.</p>
To co-operate with Local Committees in Excavations on Roman Sites in Britain.	<p><i>Chairman.</i>—Professor W. Ridgeway.  <i>Secretary.</i>—Professor R. C. Bosanquet.            Dr. T. Ashby, Mr. Willoughby Gardner, and Professor J. L. Myres.</p>

## SECTION I.—PHYSIOLOGY.

To acquire further knowledge, Clinical and Experimental, concerning Anæsthetics—general and local—with special reference to Deaths by or during Anæsthesia, and their possible diminution.	<p><i>Chairman.</i>—Dr. A. D. Waller.  <i>Secretary.</i>—            Dr. Blumfeld, Mr. J. A. Gardner, and Dr. G. A. Buckmaster.</p>
Electromotive Phenomena in Plants.	<p><i>Chairman.</i>—Dr. A. D. Waller.  <i>Secretary.</i>—Mrs. Waller.            Professors J. B. Farmer, T. Johnson, and Veley, and Dr. F. O'B. Ellison.</p>
To investigate the Physiological and Psychological Factors in the production of Miners' Nystagmus.	<p><i>Chairman.</i>—Professor J. H. Muirhead.  <i>Secretary.</i>—Dr. T. G. Maitland.            Dr. J. Jameson Evans and Dr. C. S. Myers.</p>
Colour Vision and Colour Blindness.	<p><i>Chairman.</i>—Professor E. H. Starling.  <i>Secretary.</i>—Dr. Edridge-Green.            Professor A. W. Porter, Dr. A. D. Waller, Professor C. S. Sherrington, and Dr. F. W. Mott.</p>
The Binocular Combination of Kinetograph Pictures of different Meaning, and its relation to the Binocular Combination of simpler Perceptions.	<p><i>Chairman.</i>—Dr. C. S. Myers.  <i>Secretary.</i>—Mr. T. H. Pear.</p>

2. *Not Receiving Grants of Money*—continued.

Subject for Investigation, or Purpose	Members of Committee
Further Researches on the Structure and Function of the Mammalian Heart.	<i>Chairman.</i> —Professor C. S. Sherrington. <i>Secretary.</i> —Professor Stanley Kent. Dr. Florence Buchanan.
Physiological Standards of Food and Work.	<i>Chairman and Secretary.</i> —Dr. A. D. Waller. Professors W. D. Halliburton and W. H. Thompson.
<b>SECTION K.—BOTANY.</b>	
To carry out a Research on the Influence of varying percentages of Oxygen and of various Atmospheric Pressures upon Geotropic and Heliotropic Irritability and Curvature.	<i>Chairman.</i> —Professor F. O. Bower. <i>Secretary.</i> —Professor A. J. Ewart. Professor F. F. Blackman.
The Collection and Investigation of Material of Australian Cycadaceæ, especially <i>Bowenia</i> from Queensland and <i>Macrozamia</i> from West Australia.	<i>Chairman.</i> —Professor A. A. Lawson. <i>Secretary.</i> —Professor T. G. B. Osborn. Professor A. C. Seward.
To cut Sections of Australian Fossil Plants, with especial reference to a specimen of <i>Zygopteris</i> from Simpson's Station, Barraba, N.S.W.	<i>Chairman.</i> —Professor Lang. <i>Secretary.</i> —Professor T. G. B. Osborn. Professors T. W. Edgeworth David and A. C. Seward.
The Investigation of the Vegetation of Ditcham Park, Hampshire.	<i>Chairman.</i> —Mr. A. G. Tansley. <i>Secretary.</i> —Mr. R. S. Adamson. Dr. C. E. Moss and Professor R. H. Yapp.
The Renting of Cinchona Botanic Station in Jamaica.	<i>Chairman.</i> —Professor F. O. Bower. <i>Secretary.</i> —Professor R. H. Yapp Professors R. Buller, F. W. Oliver, and F. E. Weiss.
The Structure of Fossil Plants.	<i>Chairman.</i> —Professor F. W. Oliver. <i>Secretary.</i> —Professor F. E. Weiss. Mr. E. Newell Arber, Professor A. C. Seward, and Dr. D. H. Scott.
To consider how to bring into closer contact those carrying out Scientific Breeding Experiments and those commercially interested in the results of such experiments.*	<i>Chairman.</i> —Professor W. Bateson. <i>Secretary.</i> —Miss E. R. Saunders. Mr. E. S. Beaven, Mr. L. Doncaster, Mr. R. P. Gregory, Mr. R. D. Laurie, and Dr. F. Keeble.
To consider and report upon the necessity for further provision for the Organisation of Research in Plant Pathology in the British Empire.	<i>Chairman.</i> —Professor M. C. Potter. <i>Secretary.</i> —Mr. W. B. Brierley. Mr. F. T. Brooks, Professor T. Johnson, Mr. J. Ramsbottom, Mr. E. S. Salmon, Dr. E. N. Thomas, and Mr. H. W. T. Wager.

\* Joint Committee with Sections D and M.



*Communication ordered to be printed in extenso.*

*Section E.*—Sir T. H. Holdich on 'Political Boundaries.'

*Resolutions referred to the Council for consideration, and, if desirable, for action.*

*From Sections D and E.*

That it be recommended to the Council that a grant of £100 from the Caird Fund be made to Dr. W. S. Bruce for the upkeep of the Scottish Oceanographical Laboratory.

*From Section K.*

That the Council be recommended to ask the Government to make Section K a grant of 500 reprints of a list of economic plant products which has been prepared by Sir David Prain and is shortly to be published in the Kew Bulletin.

*From Section L.*

The Committee of Section L has evidence that the separate issue of the sectional transactions has been of considerable utility both during and after the Meetings, and it regrets their discontinuance. While recognising that there are special difficulties as regards printing and paper at the present time, the Committee hopes that the Council will resume next year the publication of the sectional transactions containing the President's Address, Reports of Committees, and Abstracts of Papers.

---

*Synopsis of Grants of Money appropriated for Scientific Purposes by the General Committee at the Newcastle Meeting, September 1916. The Names of Members entitled to call on the General Treasurer for Grants are prefixed to the respective Committees.*

*Section A.—Mathematical and Physical Science.*

	£	s.	d.
*Turner, Professor H. H.—Seismological Observations .....	100	0	0
*Rutherford, Sir E.—Tables of Constants .....	40	0	0
*Hill, Professor M. J. M.—Mathematical Tables .....	20	0	0
*Love, Professor A. E. H.—Gravity at Sea .....	10	0	0

*Section B.—Chemistry.*

*Armstrong, Professor H. E.—Dynamic Isomerism .....	15	0	0
*Armstrong, Professor H. E.—Eucalypts .....	30	0	0
*Dobbie, Sir J. J.—Absorption Spectra, &c. ....	10	0	0

*Section C.—Geology.*

*Cole, Professor Grenville.—Old Red Sandstone Rocks of Kiltoran .....	4	0	0
*Watts, Professor W. W.—Critical Sections in Palæozoic Rocks .....	20	0	0

\* Reappointed.

<i>Section D.—Zoology.</i>		£	s.	d.
*Herdman, Professor W. A.—Abrolhos Islands.....		6	0	0
Bateson, Professor W.—Inheritance in Silkworms .....		20	0	0
<i>Section F.—Economic Science and Statistics.</i>				
*Muirhead, Professor J. H.—Fatigue from Economic Stand- point .....		40	0	0
*Scott, Professor W. R.—Women in Industry .....		20	0	0
*Scott, Professor W. R.—Effects of War on Credit, &c. ....		10	0	0
<i>Section G.—Engineering.</i>				
*Perry, Professor J.—Complex Stress Distributions .....		40	0	0
<i>Section H.—Anthropology.</i>				
*Smith, Professor G. Elliot.—Physical Characters of Ancient Egyptians.....		2	11	11
*Marett, Dr. R. R.—Palæolithic Site in Jersey .....		30	0	0
*Myres, Professor J. L.—Archæological Investigations in Malta .....		20	0	0
*Myres, Professor J. L.—Distribution of Bronze Age Imple- ments .....		1	14	3
*Dawkins, Professor Boyd.—Artificial Islands in Highland Lochs .....		5	0	0
<i>Section I.—Physiology.</i>				
*Schäfer, Sir E.—Ductless Glands .....		15	0	0
Carr, Dr. Willdon.—Psychological War-Research .....		10	0	0
<i>Section K.—Botany.</i>				
*Blackman, Professor F. F.—Heredity .....		45	0	0
Wager, Mr. H. W. T.—Ecology of Fungi.....		8	0	0
<i>Section L.—Education.</i>				
*Myers, Dr. C. S.—Mental and Physical Factors .....		10	0	0
*Auden, Dr. G. A.—School Books and Eyesight .....		5	0	0
*Green, Professor J. A.—Museums .....		15	0	0
*Buckmaster, Mr. C. A.—‘Free-place’ System .....		15	0	0
Gregory, Professor R. A.—Science Teaching in Secondary Schools .....		10	0	0
<i>Corresponding Societies Committee.</i>				
*Whitaker, Mr. W.—For Preparation of Report .....		25	0	0
Total .....		£602	6	2

## CAIRD FUND.

An unconditional gift of 10,000*l.* was made to the Association at the Dundee Meeting, 1912, by Mr. (afterwards Sir) J. K. Caird, LL.D., of Dundee.

\* Reappointed.

The Council in its Report to the General Committee at the Birmingham Meeting made certain recommendations as to the administration of this Fund. These recommendations were adopted, with the Report, by the General Committee at its meeting on September 10, 1913.

The following allocations have been made from the Fund by the Council to September 1916 :—

*Naples Zoological Station Committee* (p. lxii).—50*l.* (1912-13); 100*l.* (1913-14); 100*l.* annually in future, subject to the adoption of the Committee's report.

*Seismology Committee* (p. liv).—100*l.* (1913-14); 100*l.* annually in future, subject to the adoption of the Committee's report.

*Radiotelegraphic Committee* (p. lx).—500*l.* (1913-14).

*Magnetic Re-survey of the British Isles* (in collaboration with the Royal Society).—250*l.*

*Committee on Determination of Gravity at Sea* (p. liv).—100*l.* (1914-15).

*Mr. F. Sargent, Bristol University, in connection with his Astronomical Work.*—10*l.* (1914).

*Organising Committee of Section F (Economics), towards expenses of an Enquiry into Outlets for Labour after the War.*—100*l.* (1915).

*Rev. T. E. R. Phillips, for aid in transplanting his private observatory.*—20*l.* (1915).

*Committee on Fuel Economy.*—25*l.* (1915-16).

Sir J. K. Caird, on September 10, 1913, made a further gift of 1,000*l.* to the Association, to be devoted to the study of Radio-activity.

#### PUBLIC OR CITIZENS' LECTURES.

During the Meeting the following Citizens' Lectures were arranged, in co-operation with the local branch of the Workers' Educational Association, in Newcastle and the neighbourhood :—

##### NEWCASTLE.

September 4th at 7.30 P.M. in the Town Hall, Dr. Dugald Clerk, F.R.S., on 'Gas, Oil, and Petrol Engines.'

September 6th at 7.30 P.M. in the Town Hall, Mr. A. L. Smith, M.A., Master of Balliol College, Oxford, on 'Education after the War.'

##### SUNDERLAND.

September 8th at 7.30 P.M. in the Victoria Hall, Dr. F. A. Dixey, F.R.S., on 'Warfare in Nature.'

##### DURHAM.

September 5th at 7.45 P.M. in the Miners' Hall, Red Hill, Professor J. W. Gregory, F.R.S., on 'The Evolution of Geography.'

##### ASHINGTON.

September 7th at 7.15 P.M. in the Philharmonic Hall, Professor A. W. Kirkaldy, M.A., on 'The Economic Outlook after the War.'



PRESIDENT'S ADDRESS.

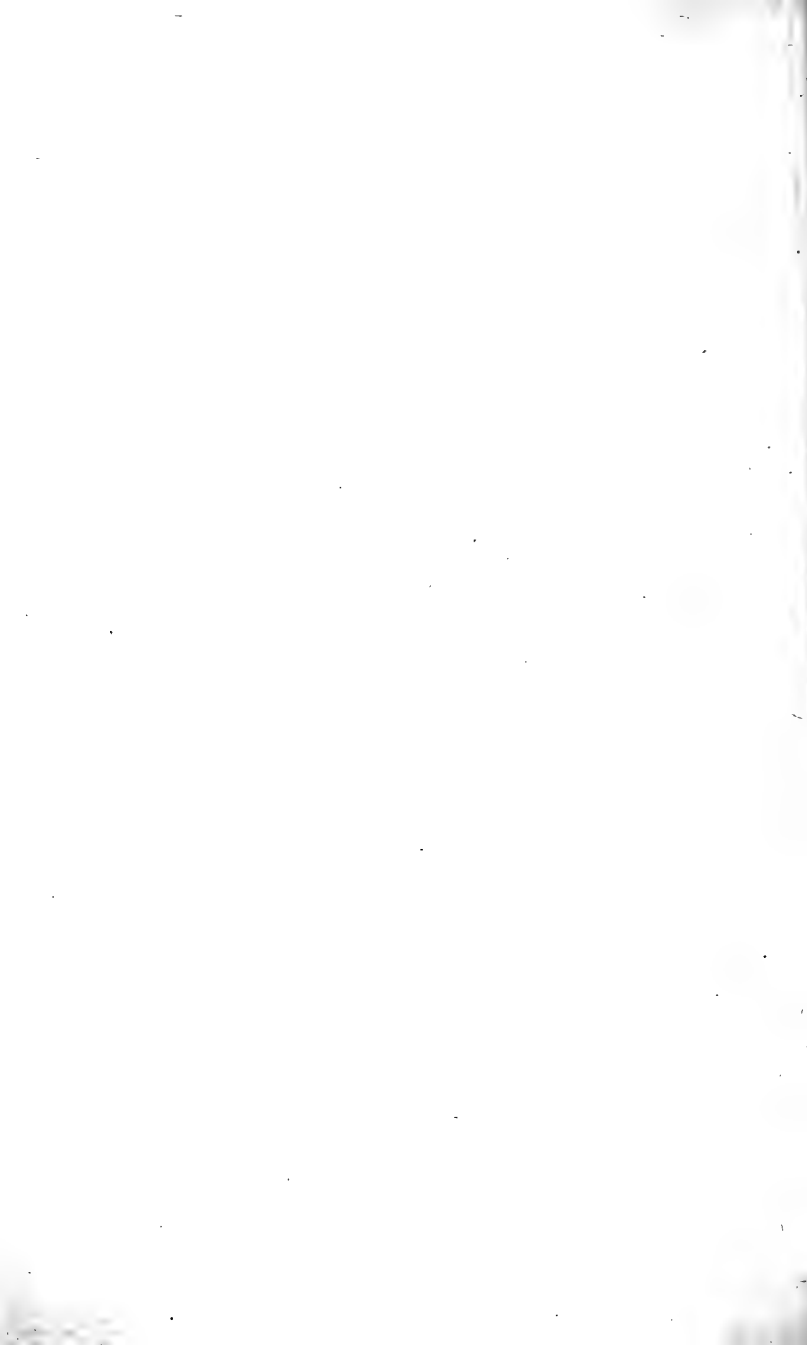

## ADDRESS

BY

SIR ARTHUR EVANS, D.LITT., LL.D., P.S.A., F.R.S.,

EXTRAORDINARY PROFESSOR OF PREHISTORIC ARCHÆOLOGY, OXFORD,  
CORRESPONDANT DE L'INSTITUT DE FRANCE, ETC.,

PRESIDENT.

---

*New Archæological lights on the Origins of Civilisation in Europe: its  
Magdalenian forerunners in the South-West and Ægean Cradle.*

---

*Et̄ quasi cursores vitai lampada tradunt.*

WHEN I was asked on behalf of the Council of the British Association to occupy the responsible post of President at the Meeting in this great city—the third that has taken place here—I was certainly taken by surprise; the more so as my own subject of research seemed somewhat removed from what may be described as the central interests of your body. The turn of Archæology, however, I was told, had come round again on the rota of the sciences represented; nor could I be indifferent to the fact that the last Presidential Address on this theme had been delivered by my father at the Toronto Meeting of 1897.

Still, it was not till after considerable hesitation that I accepted the honour. Engaged as I have been through a series of years in the work of excavation in Crete—a work which involved not only the quarrying but the building up of wholly new materials and has entailed the endeavour to classify the successive phases of a long, continuous story—absorbed and fascinated by my own investigations—I am oppressed with the consciousness of having been less able to keep pace with the progress of fellow explorers in other departments or to do sufficient justice to their results. I will not dwell, indeed, on those disabilities that result to myself from present calls and the grave pre-occupations of the hour, that to a greater or less extent must affect us all.

But Archæology—the research of ancient civilisations—when the very foundations of our own are threatened by the New Barbarism! The investigation of the ruins of the Past—at a time when Hell seems to have been let loose to strew our Continent with havoc beyond the dreams of Attila! ‘The Science of the Spade’—at a moment when

that Science confronts us at every hour with another and a sterner significance! The very suggestion of such a subject of discourse might seem replete with cruel irony.

And yet, especially as regards the prehistoric side of Archæology, something may be said for a theme which, in the midst of Armageddon, draws our minds from present anxieties to that still, passionless domain of the Past which lies behind the limits even of historic controversies. The Science of Antiquity as there seen in its purest form depends, indeed, on evidence and rests on principles indistinguishable from those of the sister Science of Geology. Its methods are stratigraphic. As in that case the successive deposits and their characteristic contents—often of the most fragmentary kind—enable the geologist to reconstruct the fauna and flora, the climate and physical conditions, of the past ages of the world, and to follow out their gradual transitions or dislocations, so it is with the archæologist in dealing with unwritten history.

In recent years—not to speak of the revelations of Late Quaternary culture, on which I shall presently have occasion to dwell—in Egypt, in Babylonia, in Ancient Persia, in the Central Asian deserts, or, coming nearer home, in the Ægean lands, the patient exploration of early sites, in many cases of huge stratified mounds, the unearthing of buried buildings, the opening of tombs, and the research of minor relics, has reconstituted the successive stages of whole fabrics of former civilisation, the very existence of which was formerly unsuspected. Even in later periods, Archæology, as a dispassionate witness, has been continually checking, supplementing, and illustrating written history. It has called back to our upper air, as with a magician's wand, shapes and conditions that seemed to have been irrevocably lost in the night of Time.

Thus evoked, moreover, the Past is often seen to hold a mirror to the Future—correcting wrong impressions—the result of some temporary revolution in the whirligig of Time—by the more permanent standard of abiding conditions, and affording in the solid evidence of past well-being the 'substance of things hoped for.' Nowhere, indeed, has this been more in evidence than in that vexed region between the Danube and the Adriatic, to-day the home of the Serbian race, to the antiquarian exploration of which many of the earlier years of my own life were devoted.

What visions, indeed, do those investigations not recall! Imperial cities, once the seats of wide administration and of prolific mints, sunk to neglected villages, vestiges of great engineering works, bridges, aqueducts, or here a main line of ancient highway hardly traceable even as a track across the wilderness! Or, again, the signs of medieval revival above the Roman ruins—remains of once populous mining



centres scattered along the lone hillside, the shells of stately churches with the effigies, bullet-starred now, of royal founders, once champions of Christendom against the Paynim—nay, the actual relics of great rulers, lawgivers, national heroes, still secreted in half-ruined monastic retreats!

*Sunt lacrimæ rerum et mentem mortalia tangunt :*

Even the archæologist incurs more human debts, and the evocation of the Past carries with it living responsibilities!

It will be found, moreover, that such investigations have at times a very practical bearing on future developments. In connexion with the traces of Roman occupation I have recently, indeed, had occasion to point out<sup>1</sup> that the section of the great Roman road that connected the Valleys of the Po and Save across the lowest pass of the Julians, and formed part of the main avenue of communication between the Western and the Eastern provinces of the Empire, has only to be restored in railway shape to link together a system of not less value to ourselves and our Allies. For we should thus secure, via the Simplon and Northern Italy, a new and shorter Overland Route to the East, in friendly occupation throughout, which is to-day diverted by unnatural conditions past Vienna and Budapest. At a time when Europe is parcelled out by less cosmopolitan interests the evidence of Antiquity here restores the true geographical perspective.

Whole provinces of ancient history would lie beyond our ken—often through the mere loss of the works of classical authors—were it not for the results of archæological research. At other times again it has redressed the balance where certain aspects of the Ancient World have been brought into unequal prominence, it may be, by mere accidents of literary style. Even if we take the Greek World, generally so rich in its literary sources, how comparatively little should we know of its brilliant civilisation as illustrated by the great civic foundations of Magna Graecia and Sicily if we had to depend on its written sources alone. But the noble monuments of those regions, the results of excavation, the magnificent coinage—a sum of evidence illustrative in turn of public and private life, of Art and Religion, of politics and of economic conditions—have gone far to supply the lacuna.

Look, too, at the history of the Roman Empire—how defective and misleading in many departments are the literary records! It has been by methodical researches into evidence such as the above—notably in the epigraphic field—that the most trustworthy results have been worked out.

Take the case of Roman Britain. Had the lost books of Ammianus

<sup>1</sup> 'The Adriatic Slavs and the Overland Route to Constantinople.' *Geographical Journal*, 1916, p. 241 *seqq.*

relating to Britain been preserved we might have had, in his rugged style, some partial sketch of the Province as it existed in the age of its most complete Romanisation. As it is, so far as historians are concerned, we are left in almost complete darkness. Here, again, it is through archæological research that light has penetrated, and thanks to the thoroughness and persistence of our own investigators, town sites such as Silchester in Roman Britain have been more completely uncovered than those of any other Province.<sup>2</sup> Nor has any part of Britain supplied more important contributions in this field than the region of the Roman Wall, that great liminary work between the Solway and the mouth of the Tyne that once marked the Northernmost European barrier of civilised dominion.

Speaking here, on the site of Hadrian's bridge-head station that formed its Eastern key, it would be impossible for me not to pay a passing tribute, however inadequate, to the continuous work of exploration and research carried out by the Society of Antiquaries of Newcastle, now for over a hundred years in existence, worthily seconded by its sister Society on the Cumbrian side, and of which the volumes of the respective *Proceedings* and *Transactions*, *Archæologia Æliana*, and last but not least the *Lapidarium Septentrionale*, are abiding records. The basis of methodical study was here the Survey of the Wall carried out, together with that of its main military approach, the Watling Street, by MacLauchlan, under the auspices of Algernon, fourth Duke of Northumberland. And who, however lightly touching on such a theme, can overlook the services of the late Dr. Collingwood Bruce, the Grand Old Man, not only of the Wall itself, but of all pertaining to Border Antiquities, distinguished as an investigator for his scholarship and learning, whose lifelong devotion to his subject and contagious enthusiasm made the Roman Wall, as it had never been before, a household word?

New points of view have arisen, a stricter method and a greater subdivision of labour have become imperative in this as in other departments of research. We must, therefore, rejoice that local explorers have more and more availed themselves of the co-operation, and welcomed the guidance of those equipped with comparative knowledge drawn from other spheres. The British Vallum, it is now realised, must be looked at with perpetual reference to other frontier lines, such as the Germanic or the Rhætian *limes*; local remains of every kind have to be correlated with similar discoveries throughout the length and breadth of the Roman Empire.

This attitude in the investigation of the remains of Roman Britain—the promotion of which owes so much to the energy and experience of Professor Haverfield—has in recent years conducted excavation to

<sup>2</sup> See Haverfield : *Roman Britain* in 1913, p. 86.

specially valuable results. The work at Corbridge, the ancient Corstopitum, begun in 1906, and continued down to the autumn of 1914, has already uncovered throughout a great part of its area the largest urban centre—civil as well as military in character—on the line of the Wall, and the principal store-base of its stations. Here, together with well-built granaries, workshops, and barracks, and such records of civic life as are supplied by sculptured stones and inscriptions, and the double discovery of hoards of gold coins, has come to light a spacious and massively constructed stone building, apparently a military store-house, worthy to rank beside the bridge-piers of the North Tyne, among the most imposing monuments of Roman Britain. There is much here, indeed, to carry our thoughts far beyond our insular limits. On this, as on so many other sites along the Wall, the inscriptions and reliefs take us very far afield. We mark the grave-stone of a man of Palmyra, an altar of the Tyrian Hercules—its Phœnician Baal—a dedication to a pantheistic goddess of Syrian religion and the rayed effigy of the Persian Mithra. So, too, in the neighbourhood of Newcastle itself, as elsewhere on the Wall, there was found an altar of Jupiter Dolichenus, the old Anatolian God of the Double Axe, the male form of the divinity once worshipped in the prehistoric Labyrinth of Crete. Nowhere are we more struck than in this remote extremity of the Empire with the heterogeneous religious elements, often drawn from its far Eastern borders, that before the days of the final advent of Christianity, Roman dominion had been instrumental in diffusing. The Orontes may be said to have flowed into the Tyne as well as the Tiber.

I have no pretension to follow up the various affluents merged in the later course of Greco-Roman civilisation, as illustrated by these and similar discoveries throughout the Roman World. My own recent researches have been particularly concerned with the much more ancient cultural stage—that of prehistoric Crete—which leads up to the Greco-Roman, and which might seem to present the problem of origins at any rate in a less complex shape. The marvellous Minoan civilisation that has there come to light shows that Crete of four thousand years ago must unquestionably be regarded as the birth-place of our European civilisation in its higher form.

But are we, even then, appreciably nearer to the fountain-head?

A new and far more remote vista has opened out in recent years, and it is not too much to say that a wholly new standpoint has been gained from which to survey the early history of the human race. The investigations of a brilliant band of prehistoric archæologists, with the aid of representatives of the sister sciences of Geology and Palæontology, have brought together such a mass of striking materials as to place the evolution of human art and appliances in the last Quaternary Period on a far higher level than had even been suspected previously.

Following in the footsteps of Lartet and after him Rivière and Piette, Professors Cartailhac, Capitan, and Boule, the Abbé Breuil, Dr. Obermeier and their fellow investigators have revolutionised our knowledge of a phase of human culture which goes so far back beyond the limits of any continuous story that it may well be said to belong to an older World.

To the engraved and sculptured works of Man in the 'Reindeer Period' we have now to add not only such new specialities as are exemplified by the moulded clay figures of life-size bisons in the Tuc d'Audoubert Cave, or the similar high reliefs of a procession of six horses cut on the overhanging limestone brow of Cap Blanc, but whole galleries of painted designs on the walls of caverns and rock shelters.

So astonishing was this last discovery, made first by the Spanish investigator Señor de Sautuola—or rather his little daughter—as long ago as 1878, that it was not till after it had been corroborated by repeated finds on the French side of the Pyrenees—not, indeed, till the beginning of the present century—that the Palæolithic Age of these rock paintings was generally recognised. In their most developed stage, as illustrated by the bulk of the figures in the Cave of Altamira itself, and in those of Marsoulas in the Haute Garonne, and of Font de Gaume in the Dordogne, these primeval frescoes display not only a consummate mastery of natural design but an extraordinary technical resource. Apart from the charcoal used in certain outlines, the chief colouring matter was red and yellow ochre, mortars and palettes for the preparation of which have come to light. In single animals the tints are varied from black to dark and ruddy brown or brilliant orange, and so, by fine gradations, to paler nuances, obtained by scraping and washing. Outlines and details are brought out by white incised lines, and the artists availed themselves with great skill of the reliefs afforded by convexities of the rock surface. But the greatest marvel of all is that such polychrome masterpieces as the bisons, standing and couchant, or with limbs huddled together, of the Altamira Cave, were executed on the ceilings of inner vaults and galleries where the light of day has never penetrated. Nowhere is there any trace of smoke, and it is clear that great progress in the art of artificial illumination had already been made. We now know that stone lamps, decorated in one case with the engraved head of an ibex, were already in existence.

Such was the level of artistic attainment in South-Western Europe, at a modest estimate some ten thousand years earlier than the most ancient monuments of Egypt or Chaldæa! Nor is this an isolated phenomenon. One by one, characteristics, both spiritual and material, that had been formerly thought to be the special marks of later ages of mankind have been shown to go back to that earlier World. I

myself can never forget the impression produced on me as a privileged spectator of a freshly uncovered interment in one of the Balzi Rossi Caves—an impression subsequently confirmed by other experiences of similar discoveries in these caves, which together first supplied the concordant testimony of an elaborate cult of the dead on the part of Aurignacian Man. Tall skeletons of the highly-developed Cro-Magnon type lay beside or above their hearths, and protected by great stones from roving beasts. Flint knives and bone javelins had been placed within reach of their hands, chaplets and necklaces of sea-shells, fish-vertebræ, and studs of carved bone had decked their persons. With these had been set lumps of iron peroxide, the red stains of which appeared on skulls and bones, so that they might make a fitting show in the Under-world.

‘ Colours, too, to paint his body,  
Place within his hand,  
That he glisten, bright and ruddy,  
In the Spirit-Land! ’<sup>3</sup>

Nor is it only in this cult of the departed that we trace the dawn of religious practices in that older World. At Cogul we may now survey the ritual dance of nine skirted women round a male Satyr-like figure of short stature, while at Alpera a gowned sister ministrant holds up what has all the appearance of being a small idol. It can hardly be doubted that the small female images of ivory, steatite, and crystalline talc from the same Aurignacian stratum as that of the Balzi Rossi interments, in which great prominence is given to the organs of maternity, had some fetichistic intention. So, too, many of the figures of animals engraved and painted on the inmost vaults of the caves may well have been due, as M. Salomon Reinach has suggested, to the magical ideas prompted by the desire to obtain a hold on the quarries of the chase that supplied the means of livelihood.

In a similar religious connexion may be taken the growth of a whole family of signs, in some cases obviously derivatives of fuller pictorial originals, but not infrequently simplified to such a degree that they resemble or actually reproduce letters of the alphabet. Often they occur in groups like regular inscriptions, and it is not surprising that in some quarters they should have been regarded as evidence that the art of writing had already been evolved by the men of the Reindeer Age. A symbolic value certainly is to be attributed to these signs, and it must at least be admitted that by the close of the late Quaternary Age considerable advance had been made in hieroglyphic expression.

The evidences of more or less continuous civilised development reaching its apogee about the close of the Magdalenian Period have been

<sup>3</sup> Schiller, *Nadwessier's Todtenlied*.

constantly emerging from recent discoveries. The recurring 'tectiform' sign had already clearly pointed to the existence of huts or wigwams; the 'scutiform' and other types record appliances yet to be elucidated, and another sign well illustrated on a bone pendant from the Cave of St. Marcel has an unmistakable resemblance to a sledge.<sup>4</sup> But the most astonishing revelation of the cultural level already reached by primeval man has been supplied by the more recently discovered rock paintings of Spain. The area of discovery has now been extended there from the Province of Santander, where Altamira itself is situated, to the Valley of the Ebro, the Central Sierras, and to the extreme South-Eastern region, including the Provinces of Albacete, Murcia, and Almeria, and even to within the borders of Granada.

One after another, features that had been reckoned as the exclusive property of Neolithic or later Ages are thus seen to have been shared by Palæolithic Man in the final stage of his evolution. For the first time, moreover, we find the productions of his art rich in human subjects. At Cogul the sacral dance is performed by women clad from the waist downwards in well-cut gowns, while in a rock-shelter of Alpera,<sup>5</sup> where we meet with the same skirted ladies, their dress is supplemented by flying sashes. On the rock painting of the Cueva de la Vieja, near the same place, women are seen with still longer gowns rising to their bosoms. We are already a long way from Eve!

It is this great Alpera fresco which, among all those discovered, has afforded most new elements. Here are depicted whole scenes of the chase in which bow-men—up to the time of these last discoveries unknown among Palæolithic representations—take a leading part, though they had not as yet the use of quivers. Some are dancing in the attitude of the Australian Corroborees. Several wear plumed head-dresses, and the attitudes at times are extraordinarily animated. What is specially remarkable is that some of the groups of these Spanish rock paintings show dogs or jackals accompanying the hunters, so that the process of domesticating animals had already begun. Hafted axes are depicted as well as cunningly-shaped throwing sticks. In one case at least we see two opposed bands of archers—marking at any rate a stage in social development in which organised warfare was possible—the beginnings, it is to be feared, of 'kultur' as well as of culture!

Nor can there be any question as to the age of these scenes and figures, by themselves so suggestive of a much later phase of human history. They are inseparable from other elements of the same group,

<sup>4</sup> This interpretation suggested by me after inspecting the object in 1902 has been approved by the Abbé Breuil (*Anthropologie*, XIII., p. 152) and by Prof. Sollas, *Ancient Hunters*,<sup>2</sup> 1915, p. 480.

<sup>5</sup> That of Carasoles del Bosque; Breuil, *Anthropologie*, XXVI., 1915, p. 329 *seqq.*

the animal and symbolic representations of which are shared by the contemporary school of rock-painting north of the Pyrenees. Some are overlaid by palimpsests, themselves of Palæolithic character. Among the animals actually depicted, moreover, the elk and bison distinctly belong to the Late Quaternary fauna of both regions, and are unknown there to the Neolithic deposits.

In its broader aspects this field of human culture, to which, on the European side, the name of Reindeer Age may still on the whole be applied, is now seen to have been very widespread. In Europe itself it permeates a large area—defined by the boundaries of glaciation—from Poland, and even a large Russian tract, to Bohemia, the upper course of the Danube and of the Rhine, to South-Western Britain and South-Eastern Spain. Beyond the Mediterranean, moreover, it fits on under varying conditions to a parallel form of culture, the remains of which are by no means confined to the Cis-Saharan zone, where incised figures occur of animals like the long-horned buffalo (*Bubalus antiquus*) and others long extinct in that region. This Southern branch may eventually be found to have a large extension. The nearest parallels to the finer class of rock-carvings as seen in the Dordogne are, in fact, to be found among the more ancient specimens of similar work in South Africa, while the rock-paintings of Spain find their best analogies among the Bushmen.

Glancing at this Late Quaternary culture as a whole, in view of the materials supplied on the European side, it will not be superfluous for me to call attention to two important points which some observers have shown a tendency to pass over.

Its successive phases, the Aurignacian, the Solutrean, and the Magdalenian, with its decadent Azilian offshoot—the order of which may now be regarded as stratigraphically established—represent on the whole a continuous story.

I will not here discuss the question as to how far the disappearance of Neanderthal Man and the close of the Moustierian epoch represents a 'fault' or gap. But the view that there was any real break in the course of the cultural history of the Reindeer Age itself does not seem to have sufficient warrant.

It is true that new elements came in from more than one direction. On the old Aurignacian area, which had a trans-Mediterranean extension from Syria to Morocco, there intruded on the European side—apparently from the East—the Solutrean type of culture, with its perfected flint-working and exquisite laurel-leaf points. Magdalenian Man, on the other hand, great as the proficiency that he attained in the carving of horn and bone, was much behind in his flint-knapping. That there were dislocations and temporary set-backs is evident. But on every side we still note transitions and reminiscences. When,

moreover, we turn to the most striking features of this whole cultural phase, the primeval arts of sculpture, engraving, and painting, we see a gradual upgrowth and unbroken tradition. From mere outline figures and simple two-legged profiles of animals we are led on step by step to the full freedom of the Magdalenian artists. From isolated or disconnected subjects we watch the advance to large compositions, such as the hunting scenes of the Spanish rock-paintings. In the culminating phase of this art we even find impressionist works. A brilliant illustration of such is seen in the galloping herds of horses, lightly sketched by the engraver on the stone slab from the Chaumont Grotto, depicting the leader in each case in front of his troop, and its serried line—straight as that of a well-drilled battalion—in perspective rendering. The whole must be taken to be a faithful memory sketch of an exciting episode of prairie life.

The other characteristic feature of the culture of the Reindeer Age that seems to deserve special emphasis, and is almost the corollary of the foregoing, is that it cannot be regarded as the property of a single race. It is true that the finely built Cro-Magnon race seems to have predominated, and must be regarded as an element of continuity throughout, but the evidence of the co-existence of other human types is clear. Of the physical characteristics of these it is not my province to speak. Here it will be sufficient to point out that their interments, as well as their general associations, conclusively show that they shared, even in its details, the common culture of the Age, followed the same fashions, plied the same arts, and were imbued with the same beliefs as the Cro-Magnon folk. The negroid skeletons intercalated in the interesting succession of hearths and interments of the Grotte des Enfants at Grimaldi had been buried with the same rites, decked with the same shell ornaments, and were supplied with the same red colouring matter for use in the Spirit World, as we find in the other sepultures of these caves belonging to the Cro-Magnon race. Similar burial rites were associated in this country with the 'Red Lady of Paviland,' the contemporary Aurignacian date of which is now well established. A like identity of funeral custom recurred again in the sepulture of a man of the 'Brünn' race on the Eastern boundary of this field of culture.

In other words, the conditions prevailing were analogous to those of modern Europe. Cultural features of the same general character had imposed themselves on a heterogeneous population. That there was a considerable amount of circulation, indeed—if not of primitive commerce—among the peoples of the Reindeer Age is shown by the diffusion of shell or fossil ornaments derived from the Atlantic, the Mediterranean, or from inland geological strata. Art itself is less the property of one or another race than has sometimes been imagined—



indeed, if we compare those products of the modern carver's art that have most analogy with the horn and bone carvings of the Cave Men and rise at times to great excellence—as we see them, for instance, in Switzerland or Norway—they are often the work of races of very different physical types. The negroid contributions, at least in the Southern zone of this Late Quaternary field, must not be underestimated. The early steatopygous images—such as some of these of the Balzi Rossi caves—may safely be regarded as due to this ethnic type, which is also pictorially represented in some of the Spanish rock-paintings.

The nascent flame of primeval culture was thus already kindled in that Older World, and, so far as our present knowledge goes, it was in the South-Western part of our Continent, on either side of the Pyrenees, that it shone its brightest. After the great strides in human progress already made at that remote epoch, it is hard, indeed, to understand what it was that still delayed the rise of European civilisation in its higher shape. Yet it had to wait for its fulfilment through many millennia. The gathering shadows thickened and the darkness of a long night fell not on that favoured region alone, but throughout the wide area where Reindeer Man had ranged. Still the question rises—as yet imperfectly answered—were there no relay runners to pass on elsewhere the lighted torch?

Something, indeed, has been recently done towards bridging over the 'hiatus' that formerly separated the Neolithic from the Palæolithic Age—the yawning gulf between two Worlds of human existence. The Azilian—a later decadent outgrowth of the preceding culture—which is now seen partially to fill the lacuna, seems to be in some respects an impoverished survival of the Aurignacian.<sup>6</sup> The existence of this phase was first established by the long and patient investigations of Piette in the stratified deposits of the Cave of Mas d'Azil in the Ariège, from which it derives its name, and it has been proved by recent discoveries to have had a wide extension. It affords evidence of a milder and moister climate—well illustrated by the abundance of the little wood snail (*helix nemoralis*) and the increasing tendency of the Reindeer to die out in the Southern parts of the area, so that in the fabric of the characteristic harpoons deer-horns are used as substitutes. Artistic designs now fail us, but the polychrome technique of the preceding Age still survives in certain schematic and geometric figures, and in curious coloured signs on pebbles. These last first came to light in the Cave of Mas d'Azil, but they have now been found to recur much further afield in a similar association in grottoes from the neighbourhood of Basel to that of Salamanca. So like letters are some of these signs that the lively

<sup>6</sup> Breuil, *Congr. Préhist.* Geneva, 1912, p. 216

imagination of Piette saw in them the actual characters of a primeval alphabet!

The little flakes with a worked edge often known as 'pygmy flints,' which were most of them designed for insertion into bone or horn harpoons, like some Neolithic examples, are very characteristic of this stratum, which is widely diffused in France and elsewhere under the misleading name of 'Tardenoisian.' At Ofnet, in Bavaria, it is associated with a ceremonial skull burial showing the coexistence at that spot of brachycephalic and dolichocephalic types, both of a new character. In Britain, as we know, this Azilian, or a closely allied phase, is traceable as far North as the Oban Caves.

What, however, is of special interest is the existence of a northern parallel to this cultural phase, first ascertained by the Danish investigator, Dr. Sarauw, in the Lake station of Maglemose, near the West coast of Zealand. Here bone harpoons of the Azilian type occur, with bone and horn implements showing geometrical and rude animal engravings of a character divergent from the Magdalenian tradition. The settlement took place when what is now the Baltic was still the great 'Ancylus Lake,' and the waters of the North Sea had not yet burst into it. It belongs to the period of the Danish pine and birch woods, and is shown to be anterior to the earliest shell mounds of the Kitchen-midden People, when the pine and the birch had given place to the oak. Similar deposits extend to Sweden and Norway, and to the Baltic Provinces as far as the Gulf of Finland. The parallel relationship of this culture is clear, and its remains are often accompanied with the characteristic 'pygmy' flints. Breuil, however,<sup>7</sup> while admitting the late Palæolithic character of this northern branch, would bring it into relation with a vast Siberian and Altaic province, distinguished by the widespread existence of rock-carvings of animals. It is interesting to note that a rock-engraving of a reindeer, very well stylised, from the Trondhjem Fjord, which has been referred to the Maglemosian phase, preserves the simple profile rendering—two legs only being visible—of Early Aurignacian tradition.

It is worth noting that an art affiliated to that of the petroglyphs of the old Altaic region long survived in the figures of the Lapp troll-drums, and still occasionally lingers, as I have myself had occasion to observe, on the reindeer-horn spoons of the Finnish and Russian Lapps, whose ethnic relationship, moreover, points east of the Ural. The existence of a Late Palæolithic Province on the Russian side is in any case now well recognised and itself supports the idea of a later shifting North and North-East, just as at a former period

<sup>7</sup> 'Les subdivisions du paléolithique supérieur et leur signification.'—*Congrès intern. d'Anthrop. et d'Archéol. préhist.*, XIV<sup>me</sup> Sess., Genève, 1912, pp. 165, 238.

it had oscillated in a South-Western direction. All this must be regarded as corroborating the view long ago expressed by Boyd Dawkins<sup>a</sup> that some part of the old Cave race may still be represented by the modern Eskimos. Testut's comparison of the short-statured Magdalenian skeleton from the rock shelter of Chancelade in the Dordogne with that of an Eskimo certainly confirms this conclusion.

On the other hand, the evidence, already referred to, of an extension of the Late Palæolithic culture to a North African zone, including rock-sculptures depicting a series of animals extinct there in the later Age, may be taken to favour the idea of a partial continuation on that side. Some of the early rock-sculptures in the south of the continent, such as the figure of a walking elephant reproduced by Dr. Peringuey, afford the clearest existing parallels to the best Magdalenian examples. There is much, indeed, to be said for the view, of which Sollas is an exponent, that the Bushmen, who at a more recent date entered that region from the North, and whose rock-painting attained such a high level of naturalist art, may themselves be taken as later representatives of the same tradition. In their human figures the resemblances descend even to conventional details, such as we meet with at Cogul and Alpera. Once more, we must never lose sight of the fact that from the Early Aurignacian Period onwards a negroid element in the broadest sense of the word shared in this artistic culture as seen on both sides of the Pyrenees.

At least we now know that Cave Man did not suffer any sudden extinction, though on the European side, partly, perhaps, owing to the new climatic conditions, this culture underwent a marked degeneration. It may well be that, as the osteological evidence seems to imply, some outgrowth of the old Cro-Magnon type actually perpetuated itself in the Dordogne. We have certainly lengthened our knowledge of the Palæolithic. But in the present state of the evidence it seems better to subscribe to Cartailhac's view that its junction with the Neolithic has not yet been reached. There does not seem to be any real continuity between the culture revealed at Maglemose and that of the immediately superposed Early Neolithic stratum of the shell-mounds, which, moreover, as has been already said, evidence a change both in climatic and geological conditions, implying a considerable interval of time.

It is a commonplace of Archæology that the culture of the Neolithic peoples throughout a large part of Central, Northern, and Western Europe—like the newly domesticated species possessed by them—is Eurasiatic in type. So, too, in Southern Greece and the Ægean World we meet with a form of Neolithic culture which must be essentially regarded as a prolongation of that of Asia Minor.

<sup>a</sup> *Early Man in Britain*, 1880, p. 233 *seqq.*

It is clear that it is on this Neolithic foundation that our later civilisation immediately stands. But in the constant chain of actions and reactions by which the history of mankind is bound together—short of the extinction of all concerned, a hypothesis in this case excluded—it is equally certain that no great human achievement is without its continuous effect. The more we realise the substantial amount of progress of the men of the Late Quaternary Age in arts and crafts and ideas, the more difficult it is to avoid the conclusion that somewhere 'at the back of behind'—it may be by more than one route and on more than one continent, in Asia as well as Africa—actual links of connexion may eventually come to light.

Of the origins of our complex European culture this much at least can be confidently stated: the earliest extraneous sources on which it drew lay respectively in two directions—in the Valley of the Nile on one side and in that of the Euphrates on the other.

Of the high early culture in the lower Euphrates Valley our first real knowledge has been due to the excavations of De Sarzec in the Mounds of Tello, the ancient Lagash. It is now seen that the civilisation that we call Babylonian, and which was hitherto known under its Semitic guise, was really in its main features an inheritance from the earlier Sumerian race—culture in this case once more dominating nationality. Even the laws which Hammurabi traditionally received from the Babylonian Sun God were largely modelled on the reforms enacted a thousand years earlier by his predecessor, Urukagina, and ascribed by him to the inspiration of the City God of Lagash.<sup>9</sup> It is hardly necessary to insist on the later indebtedness of our civilisation to this culture in its Semitised shape, as passed on, together with other more purely Semitic elements, to the Mediterranean World through Syria, Canaan, and Phœnicia, or by way of Assyria, and by means of the increasing hold gained on the old Hittite region of Anatolia.

Even beyond the ancient Mesopotamian region which was the focus of these influences, the researches of De Morgan, Gautier, and Lampre, of the French 'Délégation en Perse,' have opened up another independent field, revealing a nascent civilisation equally ancient, of which Elam—the later Susiana—was the centre. Still further afield, moreover—some three hundred miles east of the Caspian—the interesting investigations of the Pumpelly Expedition in the mounds of Anau, near Ashkabad in Southern Turkestan, have brought to light a parallel and related culture. The painted Neolithic sherds of Anau, with their geometrical decoration, similar to contemporary ware of Elam, have suggested wide comparisons with the painted pottery of somewhat later date found in Cappadocia and other parts of Anatolia, as well as in the North Syrian regions. It has, moreover, been reasonably asked

<sup>9</sup> See L. W. King, *History of Sumer and Akkad*, p. 184.

whether another class of painted Neolithic fabrics, the traces of which extend across the Steppes of Southern Russia, and, by way of that ancient zone of migration, to the lower Danube and Northern Greece, may not stand in some original relation to the same ancient Province. The new discoveries, however, in the mounds of Elam and Anau have at most a bearing on the primitive phase of culture in parts of South-Eastern Europe that preceded the age when metal was generally in use.

Turning to the Nile Valley we are again confronted with an extraordinary revolution in the whole point of view effected during recent years. Thanks mainly to the methodical researches initiated by Flinders Petrie, we are able to look back beyond the Dynasties to the very beginnings of Egyptian civilisation. Already by the closing phase of the Neolithic and by the days of the first incipient use of metals the indigenous population had attained an extraordinarily high level. If on the one hand it displays Libyan connexions, on the other we already note the evidences of commercial intercourse with the Red Sea; and the constant appearance of large rowing vessels in the figured designs shows that the Nile itself was extensively used for navigation. Flint-working was carried to unrivalled perfection, and special artistic refinement was displayed in the manufacture of vessels of variegated breccia and other stones. The antecedent stages of many Egyptian hieroglyphs are already traceable, and the cult of Egyptian divinities, like Min, was already practised. Whatever ethnic changes may have marked the establishment of Pharaonic rule, here, too, the salient features of the old indigenous culture were taken over by the new régime. This early Dynastic period itself has also received entirely new illustration from the same researches, and the freshness and force of its artistic works in many respects outshine anything produced in the later course of Egyptian history.

The continuity of human tradition as a whole in areas geographically connected like Eurafica on the one side and Eurasia on the other has been here postulated. Since, as we have seen, the Late Palæolithic culture was not violently extinguished but shows signs of survival both North and South, we are entitled to trace elements of direct derivation from this source among the inherited acquirements that finally led up to the higher forms of ancient civilisation that arose on the Nile and the Euphrates. In many directions, we may believe, the flaming torch had been carried on by the relay runners.

But what, it may be asked, of Greece itself, where human culture reached its highest pinnacle in the Ancient World and to which we look as the principal source of our own civilisation?

Till within recent years it seemed almost a point of honour for classical scholars to regard Hellenic civilisation as a Wonder-Child,

sprung, like Athena herself, fully panoplied from the head of Zeus. The indebtedness to Oriental sources was either regarded as comparatively late or confined to such definite borrowings as the alphabet or certain weights and measures. Egypt, on the other hand, at least till Alexandrine times, was looked on as something apart, and it must be said that Egyptologists on their side were only too anxious to preserve their sanctum from profane contact.

A truer perspective has now been opened out. It has been made abundantly clear that the rise of Hellenic civilisation was itself part of a wider economy and can be no longer regarded as an isolated phenomenon. Indirectly, its relation to the greater World and to the ancient centres to the South and East has been now established by its affiliation to the civilisation of prehistoric Crete and by the revelation of the extraordinarily high degree of proficiency that was there attained in almost all departments of human art and industry. That Crete itself—the 'Mid-Sea land,' a kind of halfway house between three continents—should have been the cradle of our European civilisation was, in fact, a logical consequence of its geographical position. An outlier of Mainland Greece, almost opposite the mouths of the Nile, primitive intercourse between Crete and the further shores of the Libyan Sea was still further facilitated by favourable winds and currents. In the Eastern direction, on the other hand, island stepping-stones brought it into easy communication with the coast of Asia Minor, with which it was actually connected in late geological times.

But the extraneous influences that were here operative from a remote period encountered on the island itself a primitive indigenous culture that had grown up there from immemorial time. In view of some recent geological calculations, such as those of Baron De Geer, who by counting the number of layers of mud in Lake Ragunda has reduced the ice-free period in Sweden to 7,000 years, it will not be superfluous to emphasise the extreme antiquity that seems to be indicated for even the later Neolithic in Crete. The Hill of Knossos, upon which the remains of the brilliant Minoan civilisation have found their most striking revelation, itself resembles in a large part of its composition a great mound or Tell—like those of Mesopotamia or Egypt—formed of layer after layer of human deposits. But the remains of the whole of the later Ages represented down to the earliest Minoan period (which itself goes back to a time contemporary with the early Dynasties of Egypt—at a moderate estimate to 3400 B.C.) occupy considerably less than a half—19 feet, that is, out of a total of over 45. Such calculations can have only a relative value, but, even if we assume a more rapid accumulation of debris for the Neolithic strata and deduct a third from our calculation, they would still occupy a space of over 3,400 years, giving a total antiquity of some 9,000 years from the present

time.<sup>10</sup> No Neolithic section in Europe can compare in extent with that of Knossos, which itself can be divided by the character of its contents into an Early, Middle, and Late phase. But its earliest stratum already shows the culture in an advanced stage, with carefully ground and polished axes and finely burnished pottery. The beginnings of Cretan Neolithic must go back to a still more remote antiquity.

The continuous history of the Neolithic Age is carried back at Knossos to an earlier epoch than is represented in the deposits of its geographically related areas on the Greek and Anatolian side. But sufficient materials for comparison exist to show that the Cretan branch belongs to a vast Province of primitive culture that extended from Southern Greece and the Ægean islands throughout a wide region of Asia Minor and probably still further afield.

An interesting characteristic is the appearance in the Knossian deposits of clay images of squatting female figures of a pronouncedly steatopygous conformation and with hands on the breasts. These in turn fit on to a large family of similar images which recur throughout the above area, though elsewhere they are generally known in their somewhat developed stage, showing a tendency to be translated into stone, and finally—perhaps under extraneous influences both from the North and East—taking a more extended attitude. These clearly stand in a parallel relationship to a whole family of figures with the organs of maternity strongly developed that characterise the Semitic lands and which seem to have spread from there to Sumeria and to the seats of the Anau culture.

At the same time this steatopygous family, which in other parts of the Mediterranean basin ranges from prehistoric Egypt and Malta to the North of Mainland Greece, calls up suggestive reminiscences of the similar images of Aurignacian Man. It is especially interesting to note that in Crete, as in the Anatolian region where these primitive images occur, the worship of a Mother Goddess predominated in later times, generally associated with a divine Child—a worship which later survived in a classical guise and influenced all later religion. Another interesting evidence of the underlying religious community between Crete and Asia Minor is the diffusion in both areas of the cult of the Double Axe. This divine symbol, indeed, or 'Labrys,' became the special emblem of the Palace sanctuary of Knossos itself, which owes to it its traditional name of Labyrinth. I have already called attention to the fact that the absorptive and disseminating power of the Roman Empire brought the cult of a male form of the divinity of the Double Axe to the Roman Wall and to the actual site on which Newcastle stands.

The fact should never be left out of sight that the gifted indigenous

<sup>10</sup> For a fuller statement I must refer to my forthcoming work, *The Nine Minoan Periods* (Macmillans), Vol. I. : Neolithic Section.

stock which in Crete eventually took to itself on one hand and the other so many elements of exotic culture was still deep-rooted in its own. It had, moreover, the advantages of an insular people in taking what it wanted and no more. Thus it was stimulated by foreign influences but never dominated by them, and there is nothing here of the servility of Phœnician art. Much as it assimilated, it never lost its independent tradition.

It is interesting to note that the first quickening impulse came to Crete from the Egyptian and not from the Oriental side—the Eastern factor, indeed, is of comparatively late appearance. My own researches have led me to the definite conclusion that cultural influences were already reaching Crete from beyond the Libyan Sea before the beginning of the Egyptian Dynasties. These primitive influences are attested, amongst other evidences, by the forms of stone vessels, by the same æsthetic tradition in the selection of materials distinguished by their polychromy, by the appearance of certain symbolic signs, and the subjects of shapes and seals which go back to prototypes in use among the 'Old Race' of the Nile Valley. The impression of a very active agency indeed is so strong that the possibility of some actual immigration into the island of the older Egyptian element, due to the conquests of the first Pharaohs, cannot be excluded.

The continuous influence of Dynastic Egypt from its earliest period onwards is attested both by objects of import and their indigenous imitations, and an actual monument of a Middle Empire Egyptian was found in the Palace Court at Knossos. More surprising still are the cumulative proofs of the reaction of this early Cretan civilisation on Egypt itself, as seen not only in the introduction there of such beautiful Minoan fabrics as the elegant polychrome vases, but in the actual impress observable on Egyptian Art even on its religious side. The Egyptian griffin is fitted with Minoan wings. So, too, on the other side we see the symbols of Egyptian religion impressed into the service of the Cretan Nature Goddess, who in certain respects was partly assimilated with Hathor, the Egyptian Cow-Goddess of the Underworld.

My own most recent investigations have more and more brought home to me the all-pervading community between Minoan Crete and the land of the Pharaohs. When we realise the great indebtedness of the succeeding classical culture of Greece to its Minoan predecessor the full significance of this conclusion will be understood. Ancient Egypt itself can no longer be regarded as something apart from general human history. Its influences are seen to lie about the very cradle of our own civilisation.

The high early culture, the equal rival of that of Egypt and Babylon, which thus began to take its rise in Crete in the tenth millennium



before our era, flourished for some two thousand years, eventually dominating the Ægean and a large part of the Mediterranean basin. To the civilisation as a whole I ventured, from the name of the legendary King and law-giver of Crete, to apply the name of 'Minoan,' which has received general acceptance; and it has been possible now to divide its course into three Ages—Early, Middle, and Late, answering roughly to the successive Egyptian Kingdoms, and each in turn with a triple subdivision.

It is difficult indeed in a few words to do adequate justice to this earliest of European civilisations. Its achievements are too manifold. The many-storeyed palaces of the Minoan priest-kings in their great days, by their ingenious planning, their successful combination of the useful with the beautiful and stately, and, last but not least, by their scientific sanitary arrangements, far outdid the similar works, on however vast a scale, of Egyptian or Babylonian builders. What is more, the same skilful and commodious construction recurs in a whole series of private mansions and smaller dwellings throughout the island. Outside 'broad Knossos' itself, flourishing towns sprang up far and wide on the country sides. New and refined crafts were developed, some of them, like that of the inlaid metal-work, unsurpassed in any age or country. Artistic skill, of course, reached its acme in the great palaces themselves, the corridors, landings, and porticoes of which were decked with wall paintings and high reliefs, showing in the treatment of animal life not only an extraordinary grasp of Nature, but a grandiose power of composition such as the world had never seen before. Such were the great bull-grappling reliefs of the Sea Gate at Knossos and the agonistic scenes of the great Palace hall.

The modernness of much of the life here revealed to us is astonishing. The elaboration of the domestic arrangements, the staircases storey above storey, the front places given to the ladies at shows, their fashionable flounced robes and jackets, the gloves sometimes seen on their hands or hanging from their folding chairs, their very mannerisms as seen on the frescoes, pointing their conversation with animated gestures—how strangely out of place would it all appear in a classical design! Nowhere, not even at Pompeii, have more living pictures of ancient life been called up for us than in the Minoan Palace of Knossos. The touches supplied by its closing scene are singularly dramatic—the little bath-room opening out of the Queen's parlour, with its painted clay bath, the royal draught-board flung down in the court, the vessels for anointing and the oil-jar for their filling ready to hand by the throne of the Priest-King, with the benches of his Consistory round and the sacral griffins on either side. Religion, indeed, entered in at every turn. The palaces were also temples, the tomb a shrine of the Great Mother. It was perhaps owing to the

religious control of art that among all the Minoan representations—now to be numbered by thousands—no single example of indecency has come to light.

A remarkable feature of this Minoan civilisation cannot be passed over. I remember that at the Liverpool Meeting of this Association in 1896—just before the first results of the new discoveries in Crete were known—a distinguished archæologist took as the subject of an evening lecture 'Man before Writing,' and, as a striking example of a high culture attained by '*Analfabeti*,' singled out that of Mycenæ—a late offshoot, as we know now, from Minoan Crete. To such a conclusion, based on negative evidence, I confess I could never subscribe—for had not even the people of the Reindeer Age attained to a considerable proficiency in expression by means of symbolic signs? To-day we are able to trace the gradual evolution on Cretan soil of a complete system of writing from its earliest pictographic shape, through a conventionalised hieroglyphic to a linear stage of great perfection. In addition to inscribed sealings and other records some two thousand clay tablets have now come to light, mostly inventories or contracts; for though the script itself is still undeciphered the pictorial figures that often appear on these documents supply a valuable clue to their contents. The numeration also is clear, with figures representing sums up to 10,000. The inscribed sealings, signed, counter-marked, and counter-signed by controlling officials, give a high idea of the elaborate machinery of Government and Administration under the Minoan rulers.

The minutely organised legal conditions to which this points confirm the later traditions of Minos, the great law-giver of prehistoric Crete, who, like Hammurabi and Moses, was said to have received the law from the God of the Sacred Mountain. The clay tablets themselves were certainly due to Oriental influences, which make themselves perceptible in Crete at the beginning of the Late Minoan Age, and may have been partly resultant from the reflex action of Minoan colonisation in Cyprus. From this time onwards Eastern elements are more and more traceable in Cretan culture, and are evidenced by such phenomena as the introduction of chariots—themselves perhaps more remotely of Aryan-Iranian derivation—and by the occasional use of cylinder seals.

Simultaneously with its Eastern expansion, which affected the coast of Phœnicia and Palestine as well as Cyprus, Minoan civilisation now took firm hold of Mainland Greece, while traces of its direct influence are found in the West Mediterranean basin—in Sicily, the Balearic Islands, and Spain. At the time of the actual Conquest and during the immediately succeeding period the civilisation that appears at Mycenæ and Tiryns, at Thebes and Orchomenos, and at other centres of Mainland Greece, though it seems to have brought with it some already assimilated Anatolian elements, is still in the broadest sense

Minoan. It is only at a later stage that a more provincial offshoot came into being to which the name Mycenæan can be properly applied. But it is clear that some vanguard at least of the Aryan Greek immigrants came into contact with this high Minoan culture at a time when it was still in its most flourishing condition. The evidence of Homer itself is conclusive. Arms and armour described in the poems are those of the Minoan prime, the fabled shield of Achilles, like that of Herakles described by Hesiod, with its elaborate scenes and variegated metal-work, reflects the masterpieces of Minoan craftsmen in the full vigour of their art; the very episodes of epic combat receive their best illustration on the signets of the great days of Mycenæ. Even the lyre to which the minstrel sang was a Minoan invention. Or, if we turn to the side of religion, the Greek temple seems to have sprung from a Minoan hall, its earliest pediment schemes are adaptations from the Minoan tympanum—such as we see in the Lions' Gate—the most archaic figures of the Hellenic Goddesses, like the Spartan Orthia, have the attributes and attendant animals of the great Minoan Mother.

Some elements of the old culture were taken over on the soil of Hellas. Others which had been crushed out in their old centres survived in the more Eastern shores and islands formerly dominated by Minoan civilisation, and were carried back by Phœnician or Ionian intermediaries to their old homes. In spite of the overthrow which about the twelfth century before our era fell on the old Minoan dominion and the onrush of the new conquerors from the North, much of the old tradition still survived to form the base for the fabric of the later civilisation of Greece. Once more, through the darkness, the lighted torch was carried on, the first glimmering flame of which had been painfully kindled by the old Cave dwellers in that earlier Palæolithic World.

The Roman Empire, which in turn appropriated the heritage that Greece had received from Minoan Crete, placed civilisation on a broader basis by welding together heterogeneous ingredients and promoting a cosmopolitan ideal. If even the primeval culture of the Reindeer Age embraced more than one race and absorbed extraneous elements from many sides, how much more is that the case with our own which grew out of the Greco-Roman! Civilisation in its higher form to-day, though highly complex, forms essentially a unitary mass. It has no longer to be sought out in separate luminous centres, shining like planets through the surrounding night. Still less is it the property of one privileged country or people. Many as are the tongues of mortal men, its votaries, like the Immortals, speak a single language. Throughout the whole vast area illumined by its quickening rays, its workers are interdependent, and pledged to a common cause.

We, indeed, who are met here to-day to promote in a special way

the Cause of Truth and Knowledge, have never had a more austere duty set before us. I know that our ranks are thinned. How many of those who would otherwise be engaged in progressive research have been called away for their country's service! How many who could least be spared were called to return no more! Scientific intercourse is broken, and its cosmopolitan character is obscured by the death struggle in which whole Continents are locked. The concentration, moreover, of the Nation and of its Government on immediate ends has distracted it from the urgent reforms called for by the very evils that are the root cause of many of the greatest difficulties it has had to overcome. It is a lamentable fact that beyond any nation of the West the bulk of our people remains sunk not in comparative ignorance only—for that is less difficult to overcome—but in intellectual apathy. The dull incuria of the parents is reflected in the children, and the desire for the acquirement of knowledge in our schools and colleges is appreciably less than elsewhere. So, too, with the scientific side of education, it is not so much the actual amount of Science taught that is in question—insufficient as that is—as the instillation of the scientific spirit itself—the perception of method, the sacred thirst for investigation.

But can we yet despair of the educational future of a people that has risen to the full height of the great emergency with which they were confronted? Can we doubt that, out of the crucible of fiery trial, a New England is already in the moulding?

We must all bow before the hard necessity of the moment. Of much we cannot judge. Great patience is demanded. But let us, who still have the opportunity of doing so, at least prepare for the even more serious struggle that must ensue against the enemy in our midst, that gnaws our vitals. We have to deal with ignorance, apathy, the non-scientific mental attitude, the absorption of popular interest in sports and amusements.

And what, meanwhile, is the attitude of those in power—of our Government, still more of our permanent officials? A cheap epigram is worn threadbare in order to justify the ingrained distrust of expert, in other words of scientific, advice on the part of our public offices. We hear, indeed, of 'Commissions' and 'Enquiries,' but the inveterate attitude of our rulers towards the higher interests that we are here to promote is too clearly shown by a single episode. It is those higher interests that are the first to be thrown to the wolves. All are agreed that special treasures should be stored in positions of safety, but at a time when it might have been thought desirable to keep open every avenue of popular instruction and of intelligent diversion, the galleries of our National Museum at Bloomsbury were entirely closed for the sake of the paltriest saving—three minutes, it was calculated—of the cost of the

War to the British Treasury! That some, indeed, were left open elsewhere was not so much due to the enlightened sympathy of our politicians, as to their alarmed interests in view of the volume of intelligent protest. Our friends and neighbours across the Channel, under incomparably greater stress, have acted in a very different spirit.

It will be a hard struggle for the friends of Science and Education, and the air is thick with mephitic vapours. Perhaps the worst economy to which we are to-day reduced by our former lack of preparedness is the economy of Truth. Heaven knows!—it may be a necessary penalty. But its results are evil. Vital facts that concern our national well-being, others that even affect the cause of a lasting Peace, are constantly suppressed by official action. The negative character of the process at work which conceals its operation from the masses makes it the more insidious. We live in a murky atmosphere amidst the suggestion of the false, and there seems to be a real danger that the recognition of Truth as itself a Tower of Strength may suffer an eclipse.

It is at such a time and under these adverse conditions that we, whose object it is to promote the Advancement of Science, are called upon to act. It is for us to see to it that the lighted torch handed down to us from the Ages shall be passed on with a still brighter flame. Let us champion the cause of Education, in the best sense of the word, as having regard to its spiritual as well as its scientific side. Let us go forward with our own tasks, unflinchingly seeking for the Truth, confident that, in the eternal dispensation, each successive generation of seekers may approach nearer to the goal.

*MAGNA EST VERITAS, ET PRÆVALEBIT.*

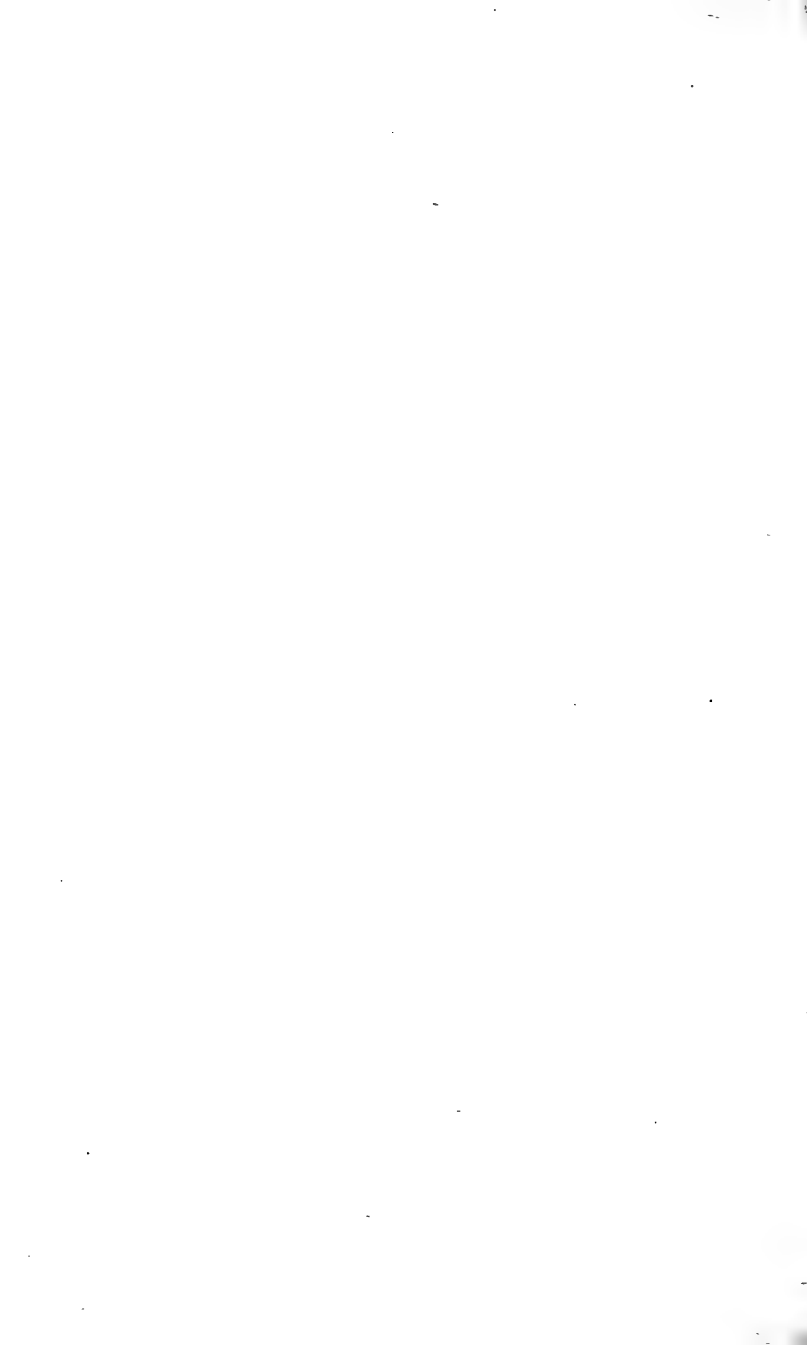



REPORTS  
ON THE  
STATE OF SCIENCE.





# REPORTS ON THE STATE OF SCIENCE.

*Seismological Investigations.—Twenty-first Report of the Committee, consisting of Professor H. H. TURNER (Chairman), Mr. J. J. SHAW (Secretary), Mr. C. VERNON BOYS, Dr. J. E. CROMBIE, Mr. HORACE DARWIN, Mr. C. DAVISON, Sir F. W. DYSON, Dr. R. T. GLAZEBROOK, Professor C. G. KNOTT, Professor H. LAMB, Sir J. LARMOR, Professor A. E. H. LOVE, Dr. H. M. MACDONALD, Professor J. PERRY, Mr. W. E. PLUMMER, Professor H. C. PLUMMER, Dr. R. A. SAMPSON, Professor A. SCHUSTER, Sir NAPIER SHAW, Dr. G. T. WALKER, and Dr. G. W. WALKER.*

[PLATE I.—FIG. 5.]

CONTENTS.		PAGE
I. <i>Personal</i>		29
II. <i>General Notes and Bulletins</i>		30
III. <i>Diurnal Wanderings of the Trace</i>		30
IV. <i>Suggested Device for Avoiding Loss of Traces</i>		32
V. <i>A Simple Device for the Better Timing of Seismograms</i>		33
VI. <i>Ledgers for each Station</i>		33
VII. <i>The Stereographic Method of Finding an Epicentre</i>		35
VIII. <i>Dr. Klotz's Tables</i>		38
IX. <i>Tables for P and S at Distances exceeding 110°—Suggestion of Essential Change in Tables near Epicentre</i>		39
X. <i>General Preliminary Discussion of the 1914 Results</i>		53

## I. *Personal.*

THE Committee has to lament the loss by death of Mr. M. H. Gray, Professor J. W. Judd, and Professor R. Meldola. The former was on many occasions a generous supporter of Professor Milne's pioneer work; the extension of the Milne Earthquake Observatory at Shide was rendered possible by his aid; and his gift of 1,000*l.* founded the Gray Fund. Professor Judd was Chairman of the Committee from 1899 to 1906 (Fourth to Eleventh Reports). It is impossible to open this Report without a brief reference to the great loss to Seismology in the recent death of Prince Galitzin. Had circumstances been more propitious, he was to have been in England this summer as Halley Lecturer at Oxford. But the war threw a great deal of responsible work upon him: indeed, it seems probable that the strain may have been too great. His invaluable services to Seismology are too well known to need comment.

At the last meeting of the Committee (Manchester, September 8, 1915) Professor J. Perry resigned the office of Secretary, which he had kindly filled temporarily, on the emergency caused by the death of Professor Milne. Mr. J. J. Shaw was elected Secretary. He has during the past year shared with the Chairman the visits of superin-

tendance to Shide, and has been unsparing in his devotion to the work of improving the Milne machines and the instrumental equipment generally.

## II. *General Notes and Bulletins.*

The Committee asks to be reappointed with a grant of 60*l.*, in addition to the annual grant of 100*l.* from the Caird Fund already voted, and 70*l.* for printing expenses. The annual budget was given in the last Report and has remained essentially the same. The Government Grant Fund administered by the Royal Society has voted a subsidy of 200*l.* for 1916 as in recent years.

Mr. Burgess is still in direct charge of the work at Shide, though he has met various difficulties during the year. His time is divided in about equal parts between Seismology and his business as a printer. The departure of his printing staff for the war made it uncertain whether he would be able to continue this arrangement. Fortunately he has found a means of doing so, at any rate for the present; and what threatened to be a critical situation has thus been tided over. Mr. Pring continues his work without change; but Miss Pring has been called away to other work in London. Her place has been taken by Miss Caws.

The Shide Bulletins were printed and distributed up to December 1914; but on the outbreak of war the material which came to hand became so scanty that it seemed doubtful whether the immediate continuation would be profitable. It seemed possible that further information might come in later, and these hopes have now been partly realised, especially as regards Russian stations. Meantime attention was turned to the discussion of the records for 1913, which had been printed in the earlier bulletins without discussion of epicentre, though collected under the separate earthquakes (instead of, as in the Shide 'Circulars,' under the observing stations). The greater part of this work is now done, and a compendious form of printing is being devised. The printing has naturally been also delayed by the interruption to Mr. Burgess's business above mentioned.

The time signals at Shide have suffered some interruptions, partly from causes not fully understood, partly from instrumental breakages, especially in the gales of the winter. The small transit instrument kindly lent by the Royal Astronomical Society has been used occasionally for check; but it received some accidental displacement which resulted in uncertain records. The source of the trouble was detected by Mr. Shaw on his visit in June last; the instrument was restored to its proper position and firmly fixed.

## III. *Diurnal Wanderings of the Traces.*

In the last Report it was remarked that the introduction of a higher magnification into the Milne-Shaw and Milne-Burgess machines had brought with it inconveniences in the unsteadiness of the trace, partly in short-period ripples as at Bidston, probably due to wind in some way; partly diurnal wanderings as at Shide. The behaviour of the two

instruments at Shide, placed close together on separate piers, was given in some detail, and its connection with internal or external temperature was discussed. The Milne-Shaw machine (M-S) was liable to wander much more than the Milne-Burgess (M-B), and the difference was provisionally set down to the difference in instrumental construction, seeing that the piers and situations were so closely similar. But the occasion of necessary small repairs to the instruments was taken as an opportunity to interchange their piers; and as a result the M-B now began to wander more than the M-S. To illustrate what happened it will perhaps suffice to give the first harmonics of the daily wanderings, the earlier of which are quoted from the last Report:—

Date	Milne-Shaw		Milne-Burgess			Phase diff.	
	Harmonic		Harmonic		Sensi- tivity		
1915	mm.	h.	mm.	mm.	h.	mm.	h.
Mar. 20	-16·8	cos ( $\theta - 18\cdot5$ )	42·0	+3·8	cos ( $\theta - 1\cdot2$ )	14·2	+6·7
May 7	-24·2	cos ( $\theta - 18\cdot0$ )	18·6	+5·6	cos ( $\theta - 20\cdot3$ )	14·2	+2·3
July 31	-5·5	cos ( $\theta - 15\cdot8$ )	18·6	+1·6	cos ( $\theta - 20\cdot5$ )	14·2	+4·9
Aug. 28	-7·4	cos ( $\theta - 15\cdot1$ )	18·6	+3·6	cos ( $\theta - 19\cdot4$ )	14·2	+4·3
Interchange of Piers							
Oct. 15	-1·6	cos ( $\theta - 6\cdot5$ )	18·0	+2·6	cos ( $\theta - 16\cdot3$ )	18·0	+9·8

Each result is deduced from the mean of several consecutive, or nearly consecutive, days, for which complete readings are available for both machines. There are some curious points about the behaviour, especially the considerable change of phase in both instruments after the interchange of piers. The changes of sensitiveness\* clearly explain a part (even a large part) of the diminution of the coefficient for M-S. But the facts (1) that the M-B coefficient exceeded the M-S after the interchange, and (2) that the difference of phase changed sensibly, seem to show that the difference of behaviour is due as much to the *piers* as the instruments; and this was specially suggested by a severe rainstorm on September 24-5, which caused the M-S trace to wander wildly, while leaving the M-B comparatively undisturbed. It is very remarkable that two piers close together in the same building, erected with the intention of being closely similar, should behave in such different ways. After the rainstorm Mr. Bullock carefully examined the foundations of the piers, but without finding anything to explain the difference of behaviour.

The figures given above show that several points require further investigation before final conclusions can be drawn; but provisionally it would appear:—

(a) That since two similar piers close together may be disturbed in sensibly, and even seriously, different ways, a locality cannot be judged on the evidence of one test pier alone. If the fault lies in the workmanship of one of the Shide piers, there may be an equally

\* Allowing for the sensitivity, the ratios of M-S to M-B are 1·5, 3·2, 2·8, and 1·5: then 0·6, after change of piers.

obscure fault in the workmanship of any test pier. If the piers (as the available evidence suggests) are really similar, then there is apparently a serious difference in foundations only a few feet apart; so that if one site is found unsteady, another not very far away may be quite steady; the whole observatory need not necessarily be removed to a distant locality.

(b) The suspicion of disability or disadvantage in the M-S machine, indicated in the last Report, is now removed. The sentences referring to it are as follows (p. 9):—

Coming to the phases, we see that there is a difference of about  $90^\circ$ , or six hours. The inference appears to be that the effect is not due to tilt of the ground, which should affect both instruments at about the same time, but an effect of temperature which acts promptly on the M-S instrument, but much more slowly on the M-B. The fact that Mr. Shaw specially designed his instrument (with a thin metal cover, &c.) so that it might take up the temperature quickly, supports this view.

We now see that, in spite of *prima facie* improbability, the difference in phase may be in great part in the ground or the piers, and not in the instruments. As a matter of fact, the thin metal covers to the M-S machine have been given up as unnecessary; and further, it need scarcely be remarked that if the design carries with it no unforeseen disability of the kind formerly suspected (but now shown to be wrongly suspected), it is a positive advantage, as was intended. The Milne-Shaw machine has by this time been thoroughly well tested with very satisfactory results; and wherever an expenditure of 50*l.* can be afforded it should replace the simple Milne machine. This recommendation has already been made to some individual observatories, and it is now made generally and definitely. That the simple Milne machine is capable of doing good work is undoubted; but its limitations, as well as its excellencies, are brought out in the Edinburgh results quoted in the Section 'Ledgers for each Station,' below; and it is an unprofitable expenditure of time and labour to continue to use it when a much more useful instrument is now available for the small expenditure of 50*l.* Mr. Shaw is making several instruments at present, but the war has brought difficulties in obtaining some essential parts. It is submitted that the *most important work of the Committee for the present lies in replacing the Milne machines*, either (where possible) by Galitzin machines or (where the expense of Galitzin machines, both capital and working expenses, is judged too great) by M-S machines.

#### IV. *Suggested Device for Avoiding Loss of Trace.*

It may be well to put on record here a suggestion of a possible device for avoiding the loss of a trace by the spot of light running off the drum. If instead of one spot of light there are two, A and B, formed, let us say, by two pin-holes close together near the lamp, then if the interval between is small enough we should get two precisely similar records on the drum side by side. But if this interval were arranged to be just less than the length of the drum, then when one

spot (A) fell in the middle of the drum, the other (B) would be quite off the drum; but if A fell close to one end, B would be close to the other; and when A ran off, B would come on. It will be clear that we really want a third spot (C) to replace A when it runs off at the other end; indeed, we might have a regular series if the wandering is liable to be large. There would undoubtedly be risk of confusion of record; but that is better than loss of record, for with patience the confusion could be unravelled, while the loss is irretrievable.

Another instrumental device may be noted here, as follows:—

#### V. *A Simple Device for the Better Timing of Seismograms.* [J. J. S.]

The essential feature of a seismogram is the precision with which its phases are timed; but unfortunately many instruments get a time-mark only every complete hour; and though this signal may be satisfactory in itself, no account is taken of any inequality in the revolution of the recording drum during each interval.

For this reason it is important that a time-mark be made every minute; but where the signals are given by the Observatory standard clock they are usually hourly, and it may be often neither convenient nor expedient to make any alteration in the standard clock.

In such circumstances an easy method of providing minute signals can be obtained by using an ordinary time-piece (costing about 2s. 6d.) to which an electric contact can be fitted; and so arranged in the timing circuit that a time-mark is made both by the standard clock and this auxiliary movement.

Only moderate precision in the small clock is required, as the interspersal of the hourly signal will give its variation during each hour; whence, by interpolation, the error of any particular minute signal may be determined.

The necessary additions to the small clock may consist of a few millimetres of thin platinum wire soldered to the second hand, or one of the arms of the minute wheel, which is arranged to wipe past a strip of platinum foil (about 20 mm. long by 3 mm. wide).

The incoming copper wire, to which the platinum foil is soldered, may be insulated from the movement by binding it to a strip of wood wedged between the plates of the movement; while the flexibility of the wire is made use of in adjusting the duration of the contact.

The out-going wire may be connected to any convenient part of the movement.

#### VI. *Ledgers for each Station.*

The completion of a year's records (1914) on the plan of the Shide Bulletins made it possible to collect the information for the various observatories in ledger form, showing date, adopted epicentre, and residuals for observed P and S. It was especially interesting to see the performance of the Milne machines; some of them, especially at out-lying stations, are of no great value; but others, such as Honolulu and Edinburgh, show very fair results. The Edinburgh results are given below in full as an example of what the Milne machine can do, especially

when there is a first-rate clock-error available. There are thirty-four cases of good or fair records of either P or S, including three cases where an obvious S was recorded at the Observatory as P, but is easily transferred: and there are only eight cases of some error at present unclassified. The mean of the P errors is  $\pm 17^{\circ}1$  and of the S errors is  $\pm 21^{\circ}3$ , part of which are undoubtedly due to errors in the tables. If we omit errors, over 50% as in Table II. which follows, these become  $\pm 17^{\circ}1$  and  $\pm 14^{\circ}6$ . Now, this is very fair observing so far as it goes; but the important fact is that in *one case only are both P and S successfully recorded* (70°3, January 20). In seventeen cases P is recorded and in seventeen cases S (the equality of the partition is remarkable), but records of this kind which give no S-P are clearly not up to modern requirements.

TABLE I.

*Records of Milne Seismograph at Edinburgh, 1914.*

$\Delta$	P	S	Date	$\Delta$	P	S	Date
°				°			
14.5	—	+55 <sup>a</sup>	June 19	74.5	—	+45	Feb. 7
23.4	(+249)=	-3	Nov. 27	75.5	—	+3	Mar. 28
25.2	-6	—	Oct. 17	75.8	+16	—	Apr. 20
25.5	—	+47	Oct. 17	75.9	+7	—	Mar. 30
30.0	+4	—	Oct. 3	79.8	-12	—	Mar. 14
30.3	—	-13	May 28	79.9	—	+30	Aug. 8
53.0	—	+5	Feb. 6	81.4	—	-51	Oct. 11
55.3	(+451)=	-5	Nov. 4	84.5	+38	—	Nov. 18
56.9	-1	—	Oct. 9	85.8	(+636)=	0	Nov. 8
59.3	+26	—	Aug. 4	86.6	+47	—	Feb. 26
60.6	+18	—	Oct. 3	87.3	—	+52	July 6
68.8	—	-29	July 21	92.4	+1	—	Feb. 26
69.5	—	-8	Mar. 18	94.5	-7	—	Nov. 24
70.0	—	-1	Mar. 6	100.5	+21	—	June 5
70.3	+6	+7	Jan. 20	101.6	+11	—	July 4
72.9	—	+8	May 28	108.2	-23	—	Oct. 23
73.5	+49	—	Jan. 30	116.5	+15	—	May 26

In addition to these good or fair records there are the following, some of which may be identified with other phases:—

$\Delta$	P	S	Date	$\Delta$	P	S	Date
60.0	—	+362	Feb. 28	117.9	—	+103	July 5
70.0	—	+106	Mar. 28	122.1	—	+1279	May 18
76.3	+98	—	July 17	139.4	-96	—	Dec. 20
102.3	+556	—	July 14	139.5	+461	—	Apr. 11

The following figures for some other stations will show how different instruments compare in the present state of the tables: but it was soon realised that the comparison is misleading, for many of the larger errors are probably due to the tables, as the discussion in Section IX. indicates. A more adequate discussion will therefore be given later. As a rough method of treating the material at present, all residuals greater

than  $\pm 50^s$  were excluded. This is far from a satisfactory procedure, but it has been applied uniformly to all stations in Table II. All observations for  $\Delta > 120^\circ$  have been omitted.

TABLE II.

Observatory	Mchn.	Mean Errors		No. Obsns. used		No. Obsns. omitted			
						$\Delta < 120^\circ$		$\Delta > 120^\circ$	
		P	S	P	S	P	S	P	S
Aachen . . . .	W	s. 12·5	s. 12·6	15	15	1	2	4	1
Adelaide . . . .	M	19·3	12·6	9	7	4	2	2	0
Baku . . . . .	G	17·6	21·1	31	25	4	7	6	4
Barcelona . . . .	Ma	11·7	21·4	11	16	6	2	3	1
Batavia . . . . .	W	13·8	28·0	24	12	7	4	0	0
Breslau . . . . .	W	9·2	16·6	14	10	4	3	1	0
Budapest . . . . .	W	11·1	13·2	16	19	3	2	3	0
Czernowitz . . . .	Ma	10·2	15·7	19	17	1	6	3	1
Edinburgh . . . .	M	16·8	15·9	18	15	2	7	2	1
Ekaterinburg . . .	G	10·4	8·7	20	19	1	4	2	1
Eskdalemuir . . . .	G	7·8	13·7	37	38	2	9	5	3
Graz . . . . .	W	9·8	14·5	24	22	3	5	2	2
Harvard . . . . .	BO	12·0	19·1	13	13	2	5	6	6
Zi-ka-wei . . . . .	W	19·0	20·7	24	21	3	8	2	2

### VII. The Stereographic Method of Finding an Epicentre.

If a large and accurate globe is available, distances between epicentre (E) and observing station (S) can be read from it with considerable accuracy; and the quickest way of finding an epicentre (approximately) is to describe arcs with centres at two or three stations for which  $\Delta$  is known (the radii being the known values of  $\Delta$ ), and to note the common point, or small area, of intersection. It may be worth remarking that before attempting to draw such arcs it is well to examine which stations give consistent records, as shown by the time at origin.

Thus for the quake on 1914 May 28<sup>d</sup> 11<sup>h</sup>·5 we have:—

	P	S	S-P	$\Delta$	P-O	O
	h. m. s.	h. m. s.	s.	°	s.	h. m. s.
Tifis . . . . .	11 29 13	11 30 54	101	8·5	129	11 27 4
Czernowitz . . . .	11 30 5	11 32 6	121	10·2	154	11 27 31
Graz . . . . .	11 31 20	11 34 39	199	17·6	252	11 27 8
Budapest . . . . .	11 30 52	11 33 57	185	16·2	235	11 26 57
Barcelona . . . . .	11 32 40	11 39 6	386	42·3	493	11 24 27
Zagreb . . . . .	11 31 8	11 34 8	180	15·7	228	11 27 20
Padova . . . . .	11 31 49	11 38 58	429	49·5	543	11 22 46

From the observed differences S-P the distances  $\Delta$  from the epicentre can be inferred, and hence the whole time of transmission of P. Applying this to the observed P we get the time at epicentre O. From these figures for O, which can thus be written down from the tables alone, it is clear that the Barcelona and Padova results will not in this

case help the determination of epicentre, and we need not draw these arcs. The others will clearly not give arcs meeting in a point, but may be drawn for trial. If the globe is of such material that pencil-marks can be made and rubbed out, the arcs can be drawn on the globe. Or a small piece of thin paper may be attached temporarily to the globe in the neighbourhood of the epicentre—a plan which allows the diagram of the arcs to be preserved for reference.

It may further be worth remarking that the time at origin O can be found without using any tables at all, owing to the fact that the times for S are to those for P very nearly in the ratio of 180 to 100, which happens to be the ratio of the Fahrenheit and Centigrade thermometer scales, and is thus readily retained in the memory. Hence the value of O may be calculated thus:—

	Tifis			Zagreb		
	h.	m.	s.	h.	m.	s.
S . . . . .	11	30	54	11	34	8
P . . . . .	11	29	13	11	31	8
<hr/>						
S-P . . . . .	1 41			3 0		
Add $\frac{1}{4}$ . . . . .	25			45		
<hr/>						
Sum . . . . .	2 6			3 45		
O . . . . .	11	27	7	11	27	23

The final O is got by subtracting from P the sum of S-P and its fourth part.

But there are certain inconveniences in using a globe, and, indeed, no large enough globe may be available. The stereographic method of projection has been in such cases found very convenient. (It was apparently proposed for this purpose in 1911 by Dr. Otto Klotz, as

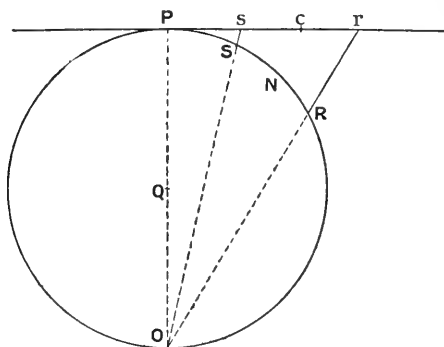

FIG. 1.

noted below; possibly also by others, as the device is well known.) It is a property of this projection that all circles on the globe project into circles, though they are generally excentric to the projection of the centre. Thus the circle on the globe with centre N (the observing station) and radius  $\Delta$  will be represented on the flat projection by a



circle, but the projected point  $n$  will not be the centre. Let  $P$  represent the North Pole (Fig. 1), and be the centre of the projection. Then if the arc  $PN$  on the sphere be  $\lambda$ , the distance  $Pn$  on the flat will be  $\tan \lambda / 2$ . Let  $S$  and  $R$  be the points where the circle with radius  $\Delta$  cuts the meridian  $PS$ , so that  $PS = \lambda - \Delta$ , and  $PR = \lambda + \Delta$ : then the corresponding points  $s$  and  $r$  are given by

$$\begin{aligned} Ps &= \tan PS/2 & Pr &= \tan PR/2 \\ &= \tan (\lambda - \Delta)/2 & &= \tan (\lambda + \Delta)/2. \end{aligned}$$

The circle on the globe projects into a circle with centre on  $Psr$ , passing through the points  $s$  and  $r$ . Hence its centre is at  $c$ , where

$$\begin{aligned} Pc &= \frac{1}{2} \left( \tan \frac{\lambda - \Delta}{2} + \tan \frac{\lambda + \Delta}{2} \right) \\ &= \frac{\sin \lambda}{\cos \lambda + \cos \Delta} \end{aligned}$$

and its radius will be

$$\frac{1}{2} \left( \tan \frac{\lambda + \Delta}{2} - \tan \frac{\lambda - \Delta}{2} \right) = \frac{\sin \Delta}{\cos \lambda + \cos \Delta}.$$

The circle can thus be drawn after a very little computation, which may be conducted either by use of

$$\tan (\lambda + \Delta)/2 \text{ and } \tan (\lambda - \Delta)/2,$$

or of the expressions

$$\frac{\sin \lambda}{\cos \lambda + \cos \Delta} \text{ and } \frac{\sin \Delta}{\cos \lambda + \cos \Delta}.$$

In this way an epicentre can be very conveniently determined on a piece of white paper.

Sometimes the circle is very large and its centre may fall off the paper in use. In this case it has been suggested by Mr. J. E. Pearson

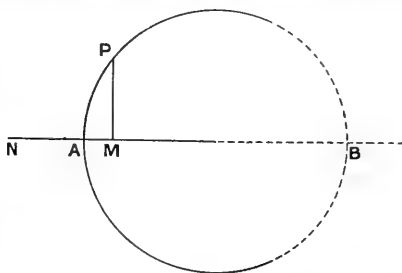

FIG. 2.

(whose volunteer aid in thus determining epicentres is gratefully acknowledged) that a very little numerical work will give the part of the circle we want. Thus in Fig. 2 let  $N$  be the North Pole and let  $A$  and  $B$  be the extremities of the diameter of the circle to be drawn. Let  $NA = 6$  inches and  $NB = 28$  inches, so that  $B$  is quite off the paper, and it is inconvenient to draw the circle. Nevertheless, we can quickly find

a point P upon it in the neighbourhood required. Taking  $AM=1$  inch, then  $PM^2=AM \times MB=1 \times 21$ .

If next we take  $AM=2$  inches, then  $PM^2=2 \times 20$ . One or two points may suffice.

#### VIII. Dr. Klotz's Tables.

In some convenient tables recently published ('Pub. Dominion Observatory, Ottawa,' vol. iii., No. 2), Dr. Klotz, who, as above remarked, proposed this method in 1911, has tabulated the values of the above expressions under a slightly different form. We have written  $\lambda$  for the polar distance of the observing station, so that if  $\phi$  be the latitude  $\lambda=90^\circ-\phi$ . Dr. Klotz has tabulated

$$d = \frac{\cos \phi}{\sin \phi + \cos \Delta} \text{ and } r = \frac{\sin \Delta}{\sin \phi + \cos \Delta}$$

for a large number of stations (not, however, including Shide, Bidston, Edinburgh, and several other British stations!). He has also given expanded tables for the times of travel of P and S, differing from those used in the Shide Bulletins by the following quantities:—

	$\Delta = 10^\circ$	$20^\circ$	$30^\circ$	$40^\circ$	$50^\circ$	$60^\circ$	$70^\circ$	$80^\circ$	$90^\circ$	$100^\circ$	$110^\circ$
	s.	s.	s.	s.	s.	s.	s.	s.	s.	s.	s.
Correction P =	-5	-4	-1	-5	-4	-3	-8	-13	-14	-17	-12
Correction S =	-5	-4	-2	-5	-3	-3	-9	-13	-15	-17	-14

It will be seen that the proposed corrections to the tables in use at Shide (which are the original Zöppritz tables) are small, and are the same for S and P, so that  $S-P$  remains unaltered. It is doubtful whether we have as yet sufficient information to be sure of these small quantities.

Dr. Klotz has very conveniently added tables for  $PR_1$ ,  $PR_2$ ,  $SR_1$ , and  $SR_2$ ; but his table and diagram for PS are apparently erroneous. He seems to have calculated this time by adding times for equal arcs for P and S.

Thus for  $\Delta=10,000$  km. he gives

$$PS-P=10^m 36^s, P=13^m 2^s, \therefore PS=23^m 38^s.$$

Now P for 5,000 km. =  $8^m 28^s$ , S for 5,000 km. =  $15^m 10^s$ .

$$\text{Sum of these last} = 23^m 38^s.$$

By this method he shows PS in his diagram as arriving always before S, whereas it always follows S when properly computed as the maximum time for a combination of P and S. For  $\Delta=10,000$  km. the correct or *maximum* time for the combination PS is given (by Klotz's tables) as about  $24^m 57^s$ , thus:—

	m. s.	m. s.	m. s.
P for 2,200 km. and S for 7,800 km. =	4 35	+ 20 20	= 24 55
P for 2,300 km. and S for 7,700 km. =	4 46	+ 20 10	= 24 56
P for 2,400 km. and S for 7,600 km. =	4 57	+ 20 0	= 24 57
P for 2,500 km. and S for 7,500 km. =	5 7	+ 19 50	= 24 57
P for 2,600 km. and S for 7,400 km. =	5 18	+ 19 39	= 24 57
P for 2,700 km. and S for 7,300 km. =	5 28	+ 19 28	= 24 56
P for 2,800 km. and S for 7,200 km. =	5 38	+ 19 17	= 24 55

This method of adding the two times together and finding the maximum or minimum is a simple and convenient practical way of

investigating possible combinations of waves when tables are available; but it is, of course, nothing more or less than the investigation of the angles of emergence as sketched in Walker's 'Seismology,' p. 54. Attention is called to the matter here, firstly because it seems possible that the publication of Dr. Klotz's table for PS may lead to some erroneous identifications, and secondly because the question is raised below whether we can have more than one reflected P wave at the same point.

Fig. 3 will show what is involved in this query. From the epicentre E, let EA and EB be two neighbouring paths for the wave P.

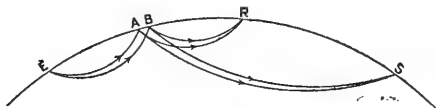

FIG. 3.

Then by regular reflection PR will be received at R, equidistant with E on the opposite side of the little reflecting portion AB. The condition may be written either

$$\text{time along EA} + \text{AR} = \text{time along EB} + \text{BR}$$

or angle of emergence at AB = angle of reflection.

Now, can both these conditions be also fulfilled, still for P waves only, at another point S? Reasons are given below for believing that they can—*i.e.* that we can have

$$\text{time along EA} + \text{AS} = \text{time along EB} + \text{BS}$$

while as regards the second condition it is only necessary that the path AS should touch the path AR at A, the curvature being clearly different; and similarly BS touch BR at B. We proceed to examine this evidence, which is based on the study of records at stations distant more than  $100^\circ$  from the epicentre.

#### IX. Tables for P and S at Distances exceeding $110^\circ$ .

At distances from the epicentre greater than  $110^\circ$ , the times recorded for the arrival of P and S are such as cannot be reconciled with adopted tables by any reasonable extrapolation, and to explain the anomalies various hypotheses of discontinuity in the interior of the Earth have been suggested. It is believed that these are unnecessary, and that the hypothesis outlined below will fit the facts. It calls for a modification of existing tables between the origin and  $40^\circ$  distance; and, until it is disposed of in one way or the other, the improvement of these adopted tables cannot be satisfactorily undertaken.

For the present attention will for simplicity be confined to P, though S is subject to similar treatment.

The nature of the anomalies will be seen by consideration of the following earthquake, where the recorded arrivals of P have been divided into two groups. One group can be identified with PR, but the other clearly cannot. For the times of PR, the times for half the arc according to adopted tables have been simply doubled. There is

a systematic run about the residuals for PR, which suggests a modification of the tables in the neighbourhood of  $60^{\circ}$ - $65^{\circ}$  (the mid-points of the arcs), but we shall not at present follow this thread.

*Earthquake of 1913 May 30<sup>d</sup> 11<sup>h</sup> 46<sup>m</sup> 46<sup>s</sup>.*

*Adopted Epicentre  $5^{\circ}$ .0 S.,  $154^{\circ}$ .0 E.*

TABLE III.  
PR<sub>1</sub> recorded as P.

Station	Machine	$\Delta$	Azim.	Time Observed	Time Calc <sup>d</sup> . PR <sub>1</sub>	O - C
		°	°	s.	s.	s.
Ksara . . . .	Ma	116.0	305	1194	1198	- 4
Czernowitz . . . .	Ma	118.2	324	1184	1212	- 28
Lemberg . . . .	BO	118.8	325	1222	1216	+ 6
Budapest . . . .	W	122.7	325	1235	1242	- 7
Göttingen . . . .	—	124.7	334	1272	1254	+ 18
Eskdalemuir . . . .	G	126.5	344	1292	1267	+ 25
Triest . . . .	W	126.7	326	1292	1268	+ 24
Aachen . . . .	W	127.9	335	1286	1276	+ 10

TABLE IV.  
PX recorded as P.

Station	Machine	$\Delta$	Azim.	Time Observed	Time Calc <sup>d</sup> . PR <sub>1</sub>	O - C
		°	°	s.	s.	s.
Königsberg . . . .	W	117.7	332	1142	1208	- 66
Breslau . . . .	W	121.7	330	1169	1235	- 66
Hamburg . . . .	—	123.3	335	1164	1246	- 82
Vienna . . . .	W	123.7	327	1158	1249	- 91
Graz . . . .	W	124.9	327	1163	1256	- 93
Sarajevo . . . .	W	125.0	322	1158	1257	- 99
Zagreb . . . .	W	125.5	325	1162	1260	- 98
Laibach . . . .	G	126.0	326	1162	1264	- 102
Innsbruck . . . .	Ma	127.0	329	1169	1270	- 101
Heidelberg . . . .	—	127.0	333	1196	1270	- 74
Padova . . . .	V	127.9	327	1163	1276	- 113

The first group of stations have presumably recorded PR<sub>1</sub> as P; but the second group have recorded something else, which comes from one to two minutes earlier. The records are so consistent as to suggest a real phenomenon, which we may call PX for the present. Moreover, other earthquakes give similar results; and we may adopt, provisionally, without giving further details here,

s.  
Time for PX at  $120^{\circ}$  = 1150  
" "  $130^{\circ}$  = 1180  
" "  $140^{\circ}$  = 1190

It is, however, probable that the adopted time at epicentre is in error, in which case these are subject to a constant correction.

Now, for reasons which need not be given here, it seemed possible that PX might be an anomalous reflection of P by two very unequal

arcs. In order that this may be possible the angles of incidence and reflection must be equal, and these angles depend essentially on  $\delta P$ , the difference of time for (say)  $1^\circ$ ; so that  $\delta P$  must have the same value for a large arc as for a small one. With the adopted tables this does not occur. The values of  $\delta P$  steadily diminish, as may be seen by the following figures:—

$\Delta = 0^\circ$	$10^\circ$	$20^\circ$	$30^\circ$	$40^\circ$	$50^\circ$	$60^\circ$	$70^\circ$	$80^\circ$	$90^\circ$	$100^\circ$
s.	s.	s.	s.	s.	s.	s.	s.	s.	s.	s.
$\delta P = 15.5$	15	12	10	8	7	7	6	6	5.5	5

If these figures are correct we cannot explain PX in the way suggested. It is now proposed to challenge the correctness of the figures between  $0^\circ$  and  $45^\circ$ , leaving those  $> 45^\circ$  practically unaltered. The nature of the proposed change is best seen in diagrammatic form

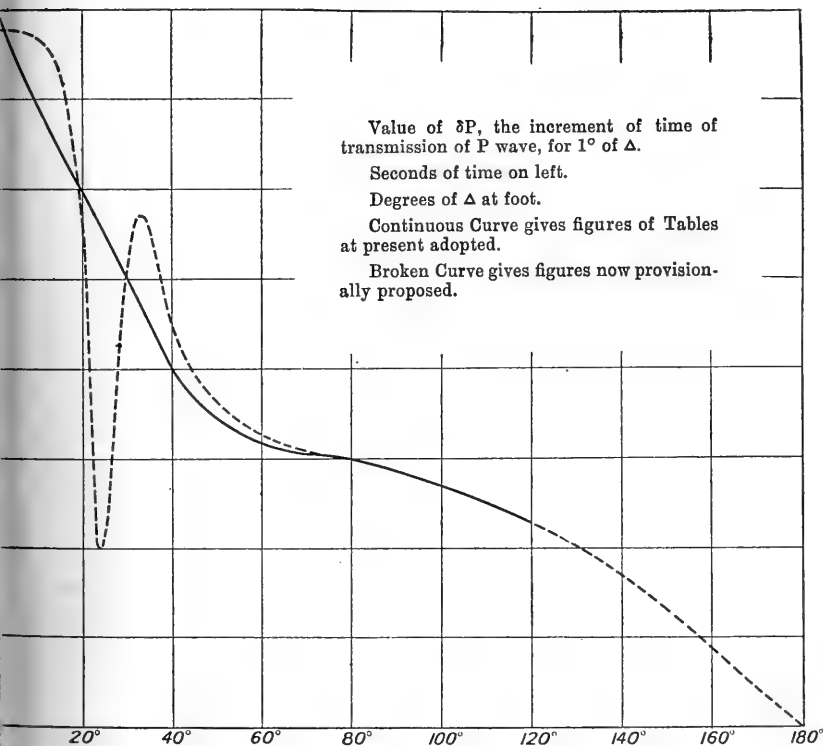

FIG. 4.

(see Fig. 4). It is suggested that there is a sharp double turn in the curve (shown by the broken line), and that the present tables have substituted a compromise which cuts across these features. Translated into figures, the suggested new tables would be

TABLE V.

$\Delta$	New	Old	N-O	$\Delta$	New	Old	N-O	$\Delta$	New	Old	N-O
°	s.	s.	s.	°	s.	s.	s.	°	s.	s.	s.
1	15	15	0	18	274	257	+17	35	420	433	-13
2	31	31	0	19	286	269	+17	36	431	442	-11
3	47	47	0	20	298	281	+17	37	442	450	-8
4	62	62	0	21	308	293	+15	38	452	458	-6
5	78	77	+1	22	315	305	+10	39	461	466	-5
6	93	92	+1	23	320	317	+3	40	470	475	-5
7	109	106	+3	24	324	328	-4	41	479	483	-4
8	124	121	+3	25	328	338	-10	42	488	491	-3
9	140	136	+4	26	333	348	-15	43	496	498	-2
10	155	150	+5	27	339	358	-19	44	504	506	-2
11	170	164	+6	28	346	368	-22	45	512	513	-1
12	186	179	+7	29	355	378	-23	46	520	520	0
13	201	193	+8	30	365	388	-23	47	527	527	0
14	216	206	+10	31	375	398	-23	48	534	534	0
15	231	219	+12	32	386	407	-21	49	540	540	0
16	246	232	+14	33	398	416	-18	50	547	547	0
17	260	245	+15	34	409	425	-16				

It will be seen that the main feature of the proposed change in the tables is a positive correction greatest about  $20^\circ$ , followed by a negative correction greatest about  $30^\circ$ . Now, this should be shown by the records, and apparently it is. The following examples will perhaps suffice for the present; a complete discussion would not only be unsuitable for this report, but requires an expenditure of time which has not yet been found possible, for the reason that records for stations near the epicentre are themselves liable to be used for determining the epicentre, so that errors of the tables may be partly compensated by adjusting the epicentre to destroy them.

If we are fortunate enough to have two stations, equipped with good instruments and time-determinations, one  $20^\circ$  from the epicentre and the other  $30^\circ$ , and in the same azimuth, then the relative errors of P above indicated could not be masked. We might alter the absolute errors in the same direction, but the difference would be unchanged. Unfortunately such cases are comparatively rare, and for the present the evidence can only be partially stated. Selected examples are as follows:—

TABLE VI.

1914 March 14<sup>d</sup> 20<sup>h</sup> 0<sup>m</sup> 6<sup>s</sup> :  $39^\circ\cdot2$  N.  $139^\circ\cdot8$  E. Determined by Pulkovo.

Station	Machine	$\Delta$	Azim.	O-C	Suggested Correction	O-C Corr <sup>d</sup> .	Epicentre Corr <sup>n</sup> .	Final
		°	°	s.	s.	s.	s.	s.
Osaka . . . . .	O	5·8	219	+28	-1	+27	-30	-3
Zi-ka-wei . . . . .	W	17·0	247	+1	-15	-14	-25	-39
Irkutsk . . . . .	G	27·6	310	-12	+20	+8	-7	+1
Manila . . . . .	W	29·6	219	-8	+23	+15	-20	+5
Tashkent . . . . .	G	52·3	297	-4	0	-4	-7	-11
Ekaterinburg . . . . .	G	52·5	317	-5	0	-5	-2	-7
Pulkovo . . . . .	G	65·4	329	0	0	0	0	0
Eskdalemuir . . . . .	G	80·4	340	-2	0	-2	+2	0

TABLE VI.—*continued.*1914 March 18<sup>d</sup> 6<sup>h</sup> 17<sup>m</sup> 36<sup>s</sup> : 54° N. 156° E. (*Pulkovo*).

Station	Machine	Δ	Azim.	O - C		Suggested Correction	O - C Corr <sup>d</sup> .	Epicentre Corr <sup>a</sup> .	Final
				s.	s.				
Osaka . . .	O	24.1	225	+ 31	+ 5	+ 36	- 40	- 4	
Irkutsk . . .	G	30.4	289	+ 2	+ 23	+ 25	- 27	- 2	
Zi-ka-wei . . .	W	33.6	241	- 53	+ 17	- 36	- 35	- 71	
Manila . . .	W	48.0	228	+ 33	0	+ 33	- 26	+ 7	
Tashkent . . .	G	56.5	296	+ 11	0	+ 11	- 15	- 4	
Pulkovo . . .	G	58.2	331	0	0	0	0	0	
Baku . . .	G	67.0	308	- 2	0	- 2	- 11	- 13	

In these two cases it looks as though the time-determination at Zi-ka-wei were faulty. [Fuller particulars are given in the *Shide Bulletin* for March.] Let us omit Zi-ka-wei from consideration for the moment. The O-C in the fifth column is that given in the *Shide Bulletins*. The suggested corrections in the next column are from the above table. When these are applied, it is seen that the stations near the origin agree better among themselves, but still differ systematically from those further away, especially Pulkovo; but at the same time it may be seen that the azimuth of the nearer stations is quite different. We can displace the epicentres at right angles to the direction of Pulkovo without disturbing its Δ or error. The effect of thus moving the epicentre 2°0 in the first case and 4°0 in the second is shown in the column 'epicentre correction.' It will be seen that all are brought into fair accord, with the above-noted exception of Zi-ka-wei; further, that the suggested corrections to the tables are in the case of Zi-ka-wei - 15° and + 17°, in opposite directions in the two earthquakes, and both tending to assimilate the errors for this station to an error in time-determination.

In the following example the suggested correction has the appearance of being in the right direction, but excessive in amount. Osaka and Batavia especially, which differed by + 8° before correction, now differ by - 23°. This may be due to error in epicentre; if again we accept Pulkovo as correct in distance, but wrong in azimuth, and accordingly move the epicentre 1°2 in the direction at right angles to Pulkovo, we get the 'epicentre corrections' shown in the 8th column.

TABLE VII.

1914 July 6<sup>d</sup> 6<sup>h</sup> 37<sup>m</sup> 24<sup>s</sup> : 24°0 N. 121°5 E. (*Shide Determination*).

Station	Machine	Δ	Azim.	O - C		Suggested Correction	Cor- rected	Epicentre Corr <sup>a</sup> .	Final
				s.	s.				
Taihoku . . .	O	1.0	0	+ 7	0	+ 7	+ 7	+ 14	
Zi-ka-wei . . .	W	7.2	359	+ 2	- 3	- 1	+ 7	+ 6	
Manila . . .	W	9.4	183	+ 5	- 4	+ 1	- 8	- 7	
Osaka . . .	O	16.1	45	0	- 14	- 14	+ 13	- 1	
Batavia . . .	W	33.4	207	- 8	+ 17	+ 9	- 8	+ 1	
Pulkovo . . .	G	70.0	328	0	0	0	0	0	

The 'final' corrections could be improved by a slight change in the distance from Pulkovo. In the next example (May 8):—

TABLE VIII.

1914 May 8<sup>d</sup> 18<sup>h</sup> 2<sup>m</sup> 0<sup>s</sup>: 37°·7 N. 15°·0 E. (*Shide Determination*).

Station	Machine	$\Delta$	Azim.	O - C	Suggested Correction	Corrected	Epicentre Corr <sup>n</sup> .	Final
		°	°	s.	s.	s.	s.	s.
Ten stations . . .	Various	<10·0	350 ±	-17	- 4	-21	-13	-34
Lemberg . . .	BO	13·4	26	-11	- 9	-20	- 4	-24
Breslau . . .	W	13·5	5	-37	- 9	-46	- 9	-55
Granada . . .	C	14·7	270	- 6	-12	-18	-12	-30
Königsberg . . .	W	17·5	11	+11	-16	- 5	- 8	-13
Tiflis . . .	G	23·2	70	-43	- 2	-45	+ 7	-38
Baku . . .	G	27·1	73	-52	+20	-32	+ 7	-25
Ekaterinburg . . .	G	35·4	42	+40	+12	(+52)	0	(+52)

[Ekaterinburg is probably PR<sub>1</sub>, which arrives 72<sup>s</sup> after P.]

the difference between Königsberg and Baku is only partly compensated by our corrections, which may be fairly set against the apparent over-compensation of the example preceding. A change of epicentre 1°·2 in the azimuth 310° (which is the best that a rough investigation suggests) cannot even now bring Königsberg and Baku quite together.

These examples (out of a number which have been already examined) will suffice to show how elaborate an investigation will probably be required to decide the point fully; moreover, it must be remembered

(a) That the precise form of the curve of correction is still to be determined, that above given being purely tentative.

(b) That the observations of S must also be taken into account. If the  $\delta P$  curve has an oscillation of the kind indicated, the cause must be sought in the arrangement of density layers as we descend into the earth; and this will affect S also. The chord of an arc of 30° lies within 150 miles of the surface of the Earth, and of an arc of 15° within 40 miles, so that the anomalies lie at no great depth, and may reasonably be placed at the limit of the Earth's 'crust.'

Without claiming more than that a case has been made out for further inquiry (which will be conducted as opportunity offers), let us now return to the phenomenon which suggested the hypothesis and see how the figures given provisionally will fit the facts. We adopt for time of P up to  $\Delta = 45^\circ$  the New Values of Table V., and from  $\Delta = 45^\circ$  onwards the figures of the table printed in the *Shide Bulletins*. Let us now add together the times for arcs of 20°, 21°, 22°, &c., to arcs of 120°, 119°, 118°, &c.:—



TABLE IX.  
Suggested Anomalous Reflection of P.

		Combined time starting at							
		120°		110°		100°		60°	
o	s.	s.	s.	s.	s.	s.	s.	s.	s.
20	298	+ 942 = 1240		+ 897 = 1195		+ 851 = 1149		+ 612 = 910	
21	308	938	1246	893	1201	845	1153	605	913
22	315	934	1249	888	1203	840	1155	599	914
23	320	929	1249	884	1204	834	1154	592	912
24	324	925	1249	879	1203	829	1158	586	910
25	328	920	1248	874	1202	823	1151	579	907
26	333	916	1249	870	1203	878	1151	573	906
27	339	911	1250	865	1204	812	1151	566	905
28	346	907	1253	860	1206	807	1153	560	906
29	355	902	1257	855	1210	801	1156	553	908
30	365	+ 897 = 1262		+ 851 = 1216		+ 796 = 1161		+ 547 = 912	

and again the same arcs of 20°, 21°, &c., to arcs of 110°, 109°, &c., as in Table IX. We start with 20° + 120°, which gives a combined arc of 140°: succeeding cases give combined arcs of 130°, 120°, and 80°, and let us look first at the last column. The time for the combined arc of 80° runs up at first from 910<sup>s</sup> to a maximum at 914<sup>s</sup>; then down to a minimum at 905<sup>s</sup>, and then pursues its original course upwards. There must be a slight pause at the maximum and the minimum, though our coarse tabulation to 1<sup>s</sup> only and to 1° of arc does not put it in evidence. These pauses make *two* anomalous reflections: but the pauses being slight, the reflected waves are probably not noticeable on the records. Look now at the first column, showing the results for 140°. The maximum and minimum have run together to make one long pause at about 1248<sup>s</sup> or 1249<sup>s</sup>: hence we get a single anomalous reflection, but much stronger; the two waves formerly separated combining to reinforce one another. This combination is beginning to disappear in favour of separation at 100° + 20° = 120°, and the separation is pronounced at 60° + 20° = 80°. About 120° therefore this anomalous reflection will die down: the precise distance at which it separates into two clearly depends upon a precise adjustment of the tables, which is scarcely yet attained. (The study of this anomalous reflection may possibly give effective help in attaining that precision.)

It is thus fairly easy to see why these reflected waves should be mistaken for the direct P at distances greater than 110°. Firstly, it must be remembered that the direct P is becoming fainter as we increase  $\Delta$  beyond 110°; secondly, the two anomalous reflections begin to coalesce and reinforce one another; and thirdly, it must be remembered that an anomalous reflection of this kind has an advantage over the direct P, and even over a regular reflection, in that it has two alternative paths by which to travel, viz., arcs of 20° + 120° and of 120° + 20°: it may make either the short or the big jump first. For regular reflection there are only the two equal jumps.

As regards the actual times of transmission, it will be seen that they accord fairly well at first with the observed times deduced for PX on p. 48.

TABLE X.

$\Delta$	Observed	Calculated	O-C <sub>1</sub>	O-C <sub>2</sub>
°	s.	s.	s.	s.
110	—	(1096)	—	—
120	1150	1152	- 2	+ 6
130	1180	1203	-23	+ 1
140	1190	1249	-59	-19

But at the same time the differences for 130° and 140° are too large to be passed over. It has been remarked in the last two Reports that the tables for P and S seem to require sensible corrections at a distance from the epicentre. For  $\Delta = 105^\circ$  the correction to time for P is given as -24<sup>s</sup>, and is rapidly increasing: a correction of -40<sup>s</sup> at  $\Delta = 115^\circ$  is not out of the question; and since the 'calculated' result for 140° depends on times for 25° + 115° the above large value of O-C may be chiefly due to the errors of adopted tables. In the column O-C<sub>2</sub> corrections to the tables have been applied. Here again we may get help in correcting the tables by study of the reflected phenomena, though direct observations of P are rare.

As one more check let us turn to the record of the earthquake of 1913, March 14, which was very carefully worked up at the I.S.A. Central Bureau by S. Szirtes ('Mitteilungen,' p. 117). His interpretation of the observations is shown by his diagram, here reproduced (Fig. 5) with the addition of a rough network of lines and some larger figures, those in the original being so small as to be scarcely legible. A scale of degrees has further been substituted for that of kilometres. (Is it not rather unfortunate that kilometres have been used so much? There are many advantages in working with degrees.) For the present we confine attention to the P curve.

First of all let us see how the suggested new tables fit the observations near the origin. For this we turn to the figures given in the accom-

TABLE XI.

1913 March 14<sup>d</sup> 8<sup>h</sup> 44<sup>m</sup> 34<sup>s</sup>. 3.5° N. 125.5° E. (Szirtes).

—	$\Delta$	Observed P	O-C <sub>1</sub>	O-C <sub>2</sub>	O-C <sub>3</sub>
	°	s.	s.	s.	s.
Manila . . .	12.0	184	+ 5	- 2	-17
Batavia . . .	21.0	332	+39	+24	+ 9
Taihoku . . .	22.0	346	+41	+31	+16
Zi-ka-wei . . .	28.0	364	- 4	+18	+ 3
Osaka . . .	32.4	410	- 1	+19	+ 4
Tsingtau . . .	33.0	409	- 7	+11	- 4
Tokyo . . .	34.8	437	+ 6	+19	+ 4
Mizusawa . . .	38.4	456	- 5	+ 1	-14
Sydney . . .	44.6	527	+17	+17	+ 2

panying text of Szirtes' paper and extract the following particulars. The errors O-C<sub>1</sub> are with the tables in use; O-C<sub>2</sub> are with the new tables above proposed. It will be seen that the new tables remove a great part of the anomaly shown by Batavia and Taihoku, and that a

menden Entfernungen die Laufzeitkurven Gültigkeit haben. Hieraus darf nur der eine Schluß gezogen werden, daß man bei der Bestimmung des Epizentrums sich

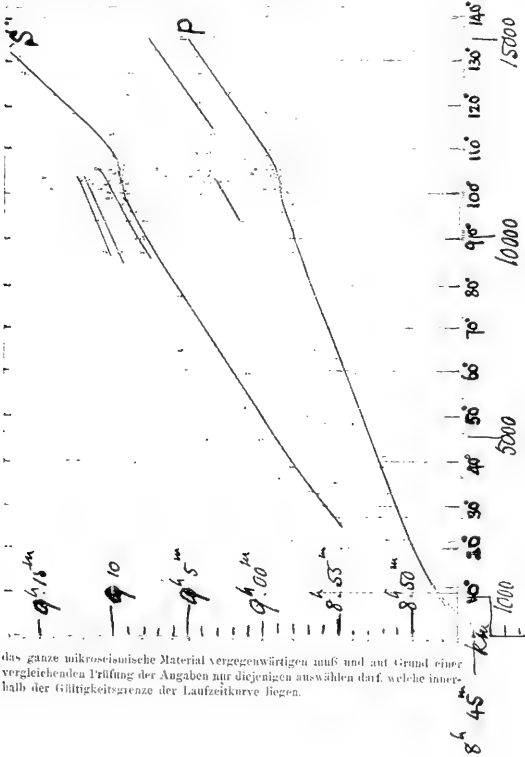

das ganze mikrosismische Material vergegenwärtigen muß und auf Grund einer vergleichenden Prüfung der Angaben nur diejenigen auswählen darf, welche innerhalb der Gültigkeitsgrenze der Laufzeitkurve liegen.

FIG. 5.



correction of about  $15^s$  to the time at origin is supported by these near stations which would also (as will be shown in a moment) bring more distant stations into better accord. The observed times being in excess, the moment at origin must be altered from  $8^h 44^m 34^s$  to  $8^h 44^m 49^s$ ; and with this time at epicentre we get the column O-C<sub>3</sub>. It is clear that Manila and Mizusawa cannot be brought into accord with the rest by any change of epicentre, for the latter lies in nearly the same azimuth as Tokyo and Osaka, while Manila is in nearly the same as Tsingtau and Zi-ka-wei.

Turning now to the results for stations more than  $90^\circ$  from the epicentre, the Szirtes' curve as drawn suggests a curious phenomenon. The slope has been nearly steady between  $30^\circ$  and  $90^\circ$ ; it then decreases, especially between  $100^\circ$  and  $150^\circ$ , and finally increases; the final slope being at the rate of five minutes in  $24^\circ$  (or  $12^s.5$  per degree, the same as that at about  $\Delta = 18^\circ$ ). Hence if this were the correct curve, we should still have the phenomenon of anomalous reflection, though in a different way. Two arcs, one of  $18^\circ$  and the other anything greater than  $108^\circ$ , would combine to give a total path of  $126^\circ$  and upwards, not because the value of  $\delta P$  falls to  $4^s$  per degree at about  $22^\circ$  from the epicentre, thus matching the small values at  $\Delta = 100^\circ$  onwards, but because the value of  $\delta P$  rises at  $12^s.5$  at distances  $> 106^\circ$ , thus matching the large value at  $\Delta = 18^\circ$ . But the correctness of this interpretation is here challenged. Surely the rate  $\delta P$  diminishes to zero at  $\Delta = 180^\circ$ ? It seems difficult to avoid the conception of a path diametrically through the earth for  $\Delta = 180^\circ$ ; and paths lying near this must be so nearly similar in all respects that the time to neighbouring points must be nearly the same. Hence near  $\Delta = 180^\circ$  the value of  $\delta P$  must tend to zero, as suggested in fig. 4; and if the graph of  $\delta P$  rises in the manner indicated by Szirtes it will have ultimately to come down again all the more.

The interpretation now put upon the records at distances greater than  $105^\circ$  from the epicentre is as follows:—

(a) Four or five are regular P waves, viz.:—

TABLE XII.

Station	$\Delta$	Observed	O-C <sub>1</sub>	O-C <sub>2</sub>	O-C <sub>3</sub>
	$^\circ$	h. m. s.	s.	s.	s.
Ucele . . .	106.2	8 59 24	+10	+35	+20
Parc St. Maur . . .	108.2	59 45	+22	+49	+34
Puy de Dôme . . .	109.3	59 47	+19	+47	+32
Cartuja . . .	117.7	9 0 5	-2	+40	+25
Chacaritos . . .	148.7	5 13	(+53)	(+53)	(+38)

The column O-C<sub>1</sub> is sensibly the same as Szirtes' results, and is got with his time at origin and the Shide tables. In O-C<sub>2</sub> the corrections to Shide tables given in the last two reports are used, viz.:—

	$\Delta = 55^\circ$	$65^\circ$	$75^\circ$	$85^\circ$	$95^\circ$	$105^\circ$	$115^\circ$
	s.	s.	s.	s.	s.	s.	s.
Corr <sup>n</sup> to P	0	-1	-3	-8	-15	-24	(-40)

The correction at  $115^\circ$  (not given before) is estimated from Table X.

TABLE XIII.

(b) The following stations apparently record PR<sub>1</sub> as P:—

Station	$\Delta$	Observed	O-C <sub>1</sub>	O-C <sub>2</sub>	O-C <sub>5</sub>
	°	h. m. s.			
Bidston . . .	108.8	9 4 24	+ 51	+ 51	+ 36
Marseilles . . .	108.8	9 3 46	+ 1	+ 1	- 14
St. Louis . . .	126.5	9 5 58	+ 17	+ 17	+ 2

The tables require no correction at the mid-points of these arcs, so that O-C<sub>2</sub> is the same as O-C<sub>1</sub>.

(c) All the remaining stations at distances exceeding 108° record PX, as follows, taking the tabular results from Table X. :—

TABLE XIV.

Station	$\Delta$	Observed	O-C <sub>1</sub>	O-C <sub>2</sub>	O-C <sub>3</sub>
	°	h. m. s.			
Algiers . . . .	113.1	9 3 31	+ 23	+ 35	+ 20
San Fernando . . .	119.9	9 4 30	+ 46	+ 61	+ 46
Ottawa . . . .	126.6	9 4 25	+ 6	+ 26	+ 11
Tacubaya . . . .	130.5	9 4 6	- 32	- 8	- 23
Harvard . . . .	131.8	9 4 19	- 26	+ 4	- 11

We may now assemble the results in a brief summary, including those for intermediate stations; individual details are omitted to save space, and it need only be remarked that three records (Simla, Apia, and Hohenheim) have been omitted as discordant, and that all the others have been given equal weight. This summary procedure is doubtless faulty, but it will suffice for present requirements.

TABLE XV.

1913 March 14<sup>d</sup> 8<sup>h</sup> 44<sup>m</sup> (54<sup>s</sup>). 3°.5 N. 125°.5 E. (Szirtes).*Records of P, PR, and PX.*

No. of Stations	Limits of $\Delta$	O-C <sub>1</sub>	O-C <sub>2</sub>	O-C <sub>3</sub>
	° °	s.	s.	s.
9	10 - 45	+ 10	+ 15	0
4	45 - 65	+ 13	+ 13	- 2
5	75 - 95	+ 3	+ 14	- 1
6	95 - 100	+ 9	+ 27	+ 12
13	100 - 104	+ 3	+ 25	+ 10
9	104 - 105	+ 8	+ 30	+ 15
4	106 - 118(a)	+ 10	+ 42	+ 27
3	108 - 127(b)	+ 23	+ 23	+ 7
5	113 - 132(c)	+ 3	+ 24	+ 9

The first three groups are in good accord, showing that the distance of the epicentre from European stations is pretty well determined. The azimuth is checked by the individual stations in the first group, already given in detail; and these records support the new tables. The

validity of the corrections to tables at distances  $75^{\circ}$ - $95^{\circ}$  is supported by the third group. After  $95^{\circ}$  the positive residuals in  $O-C_3$  indicate that the suggested corrections to P tables are perhaps excessive; but we cannot be guided by a single earthquake alone. Moreover, these corrections are still under consideration and have not been adopted. One necessary preliminary was the settlement of the anomalous records here discussed; and if these can be now regarded as due to anomalous reflections the direct P records can be re-examined with greater confidence. There is one further point which may account for part of the discordance between  $0^{\circ}$ - $95^{\circ}$  and stations beyond  $95^{\circ}$  in the above table. Several stations give two readings for P; one marked *e* and the other marked *i*. Thus:—

	$^{\circ}$	h.	m.	s.	h.	m.	s.
Baku . . .	76.8	8	56	36 <i>e</i>	8	56	42 <i>i</i> , <i>i-e</i> = 6
Pulkovo . . .	89.6	8	57	45 <i>e</i>	8	57	57 <i>i</i> , <i>i-e</i> = 12
Vienna . . .	100.0	8	58	36 <i>e</i>	8	58	43 <i>i</i> , <i>i-e</i> = 7

The first record has been taken in all cases. It seems possible that *e* might be recorded more frequently at nearer stations, but be too faint at more distant stations. But this is little more than a conjecture.

The hypothesis of an oscillation in the graph of  $\delta P$  shown in fig. 4 means that there is an oscillation of similar kind in the increase of density of the earth as we travel downwards. The interpretation suggested is that just below the 'crust' there is a layer of unexpectedly high density, in which P travels unusually quickly, followed by a return to a density which is either actually less than that of the dense layer above it, or perhaps ceases to increase at the same rate. No theoretical examination of such a possible change of density has yet been made; but it is perhaps worth noting as a speculation\* that this notable oscillation might be followed by one or more smaller ones, the effects of which on the times of P (and S) might be so small as to have been hitherto completely masked by accidental errors.

Hitherto attention has been confined to P for simplicity. But the earthquake just discussed now enables us to test the behaviour of S with facility; for the epicentre is apparently well determined, and we have found a satisfactory correction to the time at epicentre. Observations of S will thus give us at once the proper corrections to the S tables. Before examining the observations, however, let us see what we can infer about S from P. The ratio of the times for S and P is very nearly constant (1.80) for all distances from the epicentre. With the adopted (Shide) tables it is

$\Delta =$	$10^{\circ}$	$20^{\circ}$	$30^{\circ}$	$40^{\circ}$	$50^{\circ}$	$60^{\circ}$	$70^{\circ}$	$80^{\circ}$	$90^{\circ}$	$100^{\circ}$
Ratio =	1.79	1.79	1.79	1.78	1.79	1.80	1.81	1.82	1.83	1.83

thus showing a slight rise in value. But corrections to these tables have been proposed, and they tend to reduce the higher values. From what has already been said of the possible changes in the tables required

\* These words were written before the evidence of a second oscillation given below had been detected; in fact, before the S records had been examined at all.

between  $0^\circ$  and  $45^\circ$ , we confine attention to the following suggested corrections given at the end of the 1914 Report:—

	$\Delta = 55^\circ$	$65^\circ$	$75^\circ$	$85^\circ$	$95^\circ$	$105^\circ$
	s.	s.	s.	s.	s.	s.
Correction P	0	-1	-3	-8	-15	-24
Correction S	-11	-14	-17	-24	-35	-50
New Ratio	1.78	1.79	1.80	1.81	1.82	1.83

The corrections are only tentative, and definitive ones may reduce the higher values still further. The ratio S/P seems to be closely 1.80 throughout; and this, at any rate, will suffice to suggest corrections to the S tables corresponding to those for P given in Table XV. They have been formed by direct use of this factor and need not be given in detail.

The S records therefore stand as below:—

TABLE XVI.

1913 March 14<sup>d</sup> 8<sup>h</sup> 49<sup>m</sup> (49<sup>s</sup>).  $3.5^\circ$  N.  $125.5^\circ$  E.

Station	$\Delta$	Obs. S	O - C <sub>1</sub>	Corr.	O - C <sub>2</sub>	O - Y
	°	s.	s.	s.		
Manila . . . . .	12.0	234	- 85	-13	—	—
Taihoku . . . . .	22.0	415	-130	-18	—	—
Zi-ka-wei . . . . .	28.0	618	- 41	+39	- 2	—
Osaka . . . . .	32.4	689	- 45	+36	- 9	—
Tsingtau . . . . .	33.0	709	- 35	+32	- 3	—
Tokyo . . . . .	34.8	622	-150	+26	—	—
Mizusawa . . . . .	38.4	786	- 38	+11	-27	—
Sydney . . . . .	44.4	921	+ 14	+ 3	+17	—
Irkutsk . . . . .	57.9	1018	+ 15	+10	+25	—
Baku . . . . .	76.8	1236	- 71	+19	—	—
Ksara . . . . .	86.5	1390	- 25	+26	+ 1	—
Pulkovo . . . . .	89.6	1388 <sup>e</sup>	- 62	+29	-33?	+53
" . . . . .	"	1405 <sup>i</sup>	- 45	+29	-16	—
Czernowitz . . . . .	93.8	1393	-101	—	—	- 5
" . . . . .	"	1458 <sup>i</sup>	- 36	+34	- 2	—
" . . . . .	"	1485	- 18	+35	+17	—
Lemberg . . . . .	94.7	1485	- 18	+35	+17	—
Königsberg . . . . .	95.7	1421	- 92	—	—	- 4
Upsala . . . . .	95.8	1442	- 72	—	—	+15
Budapest . . . . .	98.4	1465	- 75	—	—	- 1
Breslau . . . . .	98.8	1469	- 75	—	—	- 3
Sarajevo . . . . .	99.8	1458	- 96	—	—	-14
Vienna . . . . .	100.0	1470 <sup>i</sup>	- 86	—	—	-20
" . . . . .	"	1524 <sup>i</sup>	- 32	+42	+10	—
Potsdam . . . . .	100.6	1469 <sup>e</sup>	—	—	—	-30
" . . . . .	"	1517 <sup>iv</sup>	- 45	+43	- 2	—
Graz . . . . .	100.9	1522	- 42	+43	+ 1	—
Zagreb . . . . .	100.9	1473	—	—	—	-28
" . . . . .	"	1571	+ 7	+43	+50?	—
Leipzig . . . . .	101.4	1551	- 18	+44	+26	—
Laibach . . . . .	101.8	1475	—	—	—	-42
Hamburg . . . . .	101.9	1463	—	—	—	-55
" . . . . .	"	1595 <sup>i</sup>	+ 21	+45	+66?	—
Jena . . . . .	102.0	1541	- 34	+45	+11	—
Triest . . . . .	102.4	1479	—	—	—	-47
Pola . . . . .	102.6	1477	—	—	—	-51
Göttingen . . . . .	102.7	1480	—	—	—	-50
" . . . . .	"	1537	- 44	+45	+ 1	—



TABLE XVI.—*continued.*

Station	$\Delta$	Obs. S	O-C <sub>1</sub>	Corr.	O-C <sub>2</sub>	O-Y
	o	s.	s.	s.		
Munich . . . . .	103·0	1488	—	—	—	-47
Pompeii . . . . .	103·4	1475	—	—	—	-66
Catania . . . . .	103·8	1487	—	—	—	-60
Jugenheim . . . . .	104·2	1489	—	—	—	-63
Hohenheim . . . . .	104·2	1489	—	—	—	-63
Heidelberg . . . . .	104·3	1506	—	—	—	-48
Rocca di Papa . . . . .	104·4	1491	—	—	—	-65
Zürich . . . . .	105·2	1488	—	—	—	-79
Strassburg . . . . .	105·2	1522	—	—	—	-46
Aachen . . . . .	105·3	1564 <sub>e</sub>	- 41	+ 50	+ 9	—
" . . . . .	"	1574 <sub>i</sub>	- 31	+ 50	+ 19?	—
Uccle . . . . .	106·2	1469 <sub>e</sub>	—	—	—	?
" . . . . .	"	1494 <sub>i</sub>	—	—	—	-98
Besançon . . . . .	106·8	1498	—	—	—	-93
Parc St. Maur . . . . .	108·2	1508	—	—	—	-104
Puy de Dôme . . . . .	109·3	1521	—	—	—	-107
Algiers . . . . .	113·1	1526	—	—	—	—
Cartuja . . . . .	117·7	1669	- 43	+ 90?	+ 47?	—
Victoria, B.C. . . . .	121·8	1751	—	—	—	-67
St. Louis . . . . .	126·5	1870	—	—	—	—
Ottawa . . . . .	126·6	1871	—	—	—	—
Tambaya . . . . .	130·5	1891	—	—	—	—
Chacaritos . . . . .	148·7	1793	- 117	—	—	—

The observed S (*i.e.*, the interval by which it follows 8<sup>h</sup> 44<sup>m</sup> 49<sup>s</sup>) is given in the third column, and it is compared with the adopted (Shide) tables in the next column O-C<sub>1</sub>; except that in the latter part of the table this comparison has been omitted when it obviously fails. The corrections, taken for  $\Delta > 45^\circ$  from the last two Reports, and for  $\Delta < 45^\circ$  by use of the factor 1·80 on the corrections for P in Table V., are given in the column 'Corr.,' and applied in the column O-C<sub>2</sub>. When  $\Delta > 90^\circ$  a large number of records will not fit S at all, but at first agree with the phenomenon Y or polychord suggested in the last Report. A comparison with the times suggested for Y is therefore given in the last column O-Y. We now take in order certain matters brought out by this table.

( $\alpha$ ) There are three records near the epicentre for which no explanation has as yet suggested itself, viz. Manila, Taihoku, and Tokyo. They may, of course, be mistakes, but there is a systematic character about them which seems opposed to the idea of mistakes. The average velocities are 19<sup>s</sup>·5, 18<sup>s</sup>·9, and 17<sup>s</sup>·9 per degree of  $\Delta$ , intermediate between those of P and S, and it may ultimately be found possible to assign some combination of P with S which shall explain the records; but up to the present no success has been attained in this direction.

( $\beta$ ) With these three exceptions all the records for stations up to  $\Delta = 95^\circ$  are brought into fair accord by the suggested corrections. Particularly noteworthy are the records for Zi-ka-wei, Osaka, and Tsingtau near  $\Delta = 30^\circ$ , where the correction is near one of its maxima

and is justified. The maximum in the other direction near  $\Delta = 20^\circ$  is only represented by the exceptional Taihoku record from which no conclusion can be drawn.

( $\gamma$ ) Czernowitz, Vienna, Potsdam, and Göttingen all show a double record near S, one member of which can be reasonably identified with S and the other with the phenomenon Y mentioned in the last Report. These four cases of double record are specially valuable as a guide to the others which only give one constituent, and it is easy to understand why this should generally be the earlier one. But it must be admitted at once that the *explanation* of Y given in the last Report breaks down. It cannot be a 'polychord,' at any rate not always. The growth of negative residuals in the column O-Y is too obvious and too serious to allow of the idea of a uniform arcual velocity. As remarked in the last Report, such a velocity would make Y cross S, preceding it up to about  $105^\circ$  and following it after that. The records discussed in the last Report were all in the neighbourhood of  $95^\circ$ - $100^\circ$ , where the residuals O-Y are seen to be comparatively small; the later ones are inconsistent with the crossing of S. Apparently Y (we may perhaps still retain this letter for the phenomenon, whatever it is) always precedes S [and incidentally it may be remarked that this fact really increases the chances of its being mistaken for S and so causing the apparently greater uncertainty in identification of S which is so curious, seeing that on any given record S is better marked than P]. Its time of transmission may be put as follows:—

$\Delta =$	$95$	$100$	$105$	$110$
	<small>o</small>	<small>o</small>	<small>o</small>	<small>o</small>
	<small>s.</small>	<small>s.</small>	<small>s.</small>	<small>s.</small>
	Y=1420	1470	1490	1520

Is it some combination of P and S? If we add together the times for P and S as given by the Shide tables so as to obtain these figures we get

Δ	P	S	Sum
<small>o</small>	<small>o</small>	<small>o</small>	<small>s.</small> <small>s.</small> <small>s.</small>
95	55·8	39·2	585 + 835 = 1420
100	58·6	41·4	603 + 867 = 1470
105	65·2	39·8	646 + 844 = 1490
110	70·5	39·5	680 + 840 = 1520

But, of course, as the tables stand, the values of  $\delta P$  and  $\delta S$  for such arcs are quite unequal, so that no effective combination is possible. If, however, we further modify the curve of  $\delta P$  shown in fig. 4, so that the max. near  $30^\circ$  is followed by a minimum near  $40^\circ$ , and this again by a maximum near  $60^\circ$ , then possibly we can get the values of  $\delta P$  and  $\delta S$  equal. Assuming S to be throughout in the ratio 1·79 to P, the values of  $\delta P$  near  $40^\circ$  and  $60^\circ$  must be in this ratio. Thus if  $\delta P$  falls again to 4 at  $40^\circ$ , it must rise to 7 at  $60^\circ$ , which is far from unreasonable. A provisional set of tables has been framed on these

lines and tried with fair success; but it would lead to confusion to multiply provisional sets of tables, and it is preferable to wait until they have been thoroughly tested and corrected. But the impression given by the work hitherto done is that these oscillations in the curve for  $\delta P$  are real and will explain many apparent anomalies and difficulties; and it is hoped that in the next Report satisfactory evidence of these facts may be presented.

### X.—General Preliminary Discussion of the 1914 Results.

It will be seen that the above discussion was conducted by the study of a few particular earthquakes; not from all those given in the bulletins for 1914.

Some hesitation was felt about the form in which any discussion of the 1914 residuals should take, *i.e.* how much provisional correction of tables and epicentres should be attempted first. The tables were apparently capable of improvement, and this would involve a readjustment of some epicentres. Ultimately it was decided to try collecting the results simply as they are printed, but limiting the selection to the better stations: 34 observatories were included, and 15 were omitted, the selection not being difficult when the mean errors had been formed. The residuals for P and S were grouped for every  $5^\circ$  of  $\Delta$ , except that the first group extended from the epicentre to  $10^\circ$ . The result was more definite and satisfactory than had been expected.

It was feared that it would be difficult to draw the line between large errors and definite mistakes, but when the residuals were tabulated in this form there were found to be very few cases of doubt, and their effect on the means was almost negligible. The means were taken in a variety of ways (one of which was to select the *median* or the middle residual) with inclusion or exclusion of doubtful cases; but the various alternatives were so closely accordant that the simple arithmetic mean was ultimately adopted throughout. The mean errors thus found were as in Table XVII.

TABLE XVII.

$\Delta$	P	S	$\Delta$	P	S	$\Delta$	P	S
$\circ \circ$	s.	s. <sup>*</sup>	$\circ \circ$	s.	s.	$\circ \circ$	s.	s.
0—10	- 3	+ 2	36—40	-11	-19	66—70	+7	+ 5
11—15	+12	+23	41—45	- 3	-13	71—75	-3	+ 4
16—20	0	+ 4	46—50	+ 8	+ 1	76—80	-1	- 1
21—25	- 9	-10	51—55	+ 3	- 3	81—85	-4	-10
26—30	-11	-10	56—60	+ 3	+ 5	86—90	0	-14
31—35	+ 1	-13	61—65	+ 5	+ 3	91—95	-5	-38
						96—100	-5	-57

It will be seen that both P and S show clearly the change from a sensibly positive error at  $11^\circ$ - $15^\circ$  to a negative error at  $21^\circ$ - $25^\circ$  and afterwards. This drop occurs earlier than is suggested tentatively in Table V., but gives substantially the same phenomenon as was to be

explained. We will return to this point in a moment; but first, as the above means are, except in a few cases, comparatively small, it is desirable to give some information about their probable errors. The residuals in each group were arranged in detail in order of size, and it was soon seen that those exceeding  $\pm 65^{\circ}$  from the mean were pretty clearly mistakes. It would be tedious and expensive to print all the detail: the following summaries will probably suffice. First, the total numbers of residuals for groups of  $10^{\text{sec}}$  (middle group  $11^{\text{sec}}$ ) were as in Table XVIII.

TABLE XVIII.

Rejected	s. 75	—	s. 65	—	s. 55	—	s. 45	—	s. 35	—	s. 25	—	s. 15	—	s. 5	—	s. 0
P+	48		5		6		13		16		35		50		110		232
P-	15		2		4		12		24		23		42		120		
S+	54		5		10		9		21		38		57		124		167
S-	23		3		2		11		27		44		61		101		
Sums+	102		10		148							341			399		
Sums-	38		5		147							324					

Looking first at the column 'rejected,' we see that the number of positive residuals is much greater than the number of negative. This is only to be expected if these are actual mistakes of one phenomenon for something else which would generally follow the intended reading. In the case of P there is less opportunity for reading anything which precedes than in the case of S, and accordingly the ratio of excess of + to - is greater. But even for P a wind-tremor or other accidental tremor may precede P by something like a minute, and be read in error. Now we see that there is no trace of this excess of positive residuals in the residuals between  $55^{\text{s}}$ — $46^{\text{s}}$ ; and in the column  $45^{\text{s}}$ — $36^{\text{s}}$  the excess is in the negative residuals. It is reasonable to conclude that the residuals up to about  $55^{\text{s}}$  are chiefly accidental errors, while above that they begin to make mistakes. To make fairly sure, however, of including all real observations one more column ( $65^{\text{s}}$ — $56^{\text{s}}$ ) has been included in taking the arithmetical mean, while the column  $75^{\text{s}}$ — $66^{\text{s}}$  has been rejected, and the numbers are included in the rejected totals.

Coming to the individual groups in  $\Delta$ , it seems unnecessary to give even so much detail as for these totals. The sums at the foot show that the numbers of errors  $6^{\circ}$  to  $25^{\circ}$ , on each side are rather less than the middle group  $-5^{\circ}$  to  $+5^{\circ}$ ; and the numbers in the next four columns  $26^{\circ}$ — $65^{\circ}$  are less than half these. To follow the behaviour of the groups in  $\Delta$  it will perhaps suffice to give the corresponding figures as in Table XIX.

TABLE XIX.

*Residuals (from the mean) for P arranged according to  $\Delta$ .*

$\Delta$	Re- jected —	s. —65 to —26	s. —25 to —6	s. —5 to +5	s. +6 to +25	s. +26 to +65	Re- jected +	Mean Value	Total Observa- tions used
0-10	1	5	6	7	4	6	2	s. — 3	28
11-15	0	3	8	1	6	5	2	+12	23
16-20	0	0	7	17	5	1	0	0	30
21-25	1	6	4	13	13	3	2	— 9	39
26-30	0	3	8	6	14	3	0	—11	34
31-35	3	5	6	7	4	7	2	+ 1	29
36-40	0	1	10	5	10	0	4	—11	26
41-45	0	1	8	4	10	4	2	— 3	27
46-50	1	1	6	7	8	1	4	+ 8	23
51-55	0	3	7	6	6	2	1	+ 3	24
56-60	0	3	6	14	12	0	3	+ 3	35
61-65	1	1	10	5	7	1	1	+ 5	24
66-70	1	3	21	18	3	6	1	+ 7	51
71-75	0	12	6	28	21	7	1	— 3	74
76-80	3	2	12	31	12	3	4	— 1	60
81-85	1	6	13	39	11	8	1	— 4	77
86-90	3	2	15	15	3	8	3	0	43
91-95	0	5	6	6	6	5	6	— 5	28
96-100	0	1	3	3	5	0	9	— 5	12
Totals . .	15	63	162	232	160	70	48		687

TABLE XX.

*Residuals (from the mean) for S arranged according to  $\Delta$ .*

$\Delta$	Re- jected —	s. —65 to —26	s. —25 to —6	s. —5 to +5	s +6 to + 5	s. +26 to +65	Re- jected +	Mean Value	Total Observa- tions used
0-10	0	4	5	2	3	5	0	s. + 2	19
11-15	1	4	4	2	7	4	1	+23	21
16-20	0	1	9	14	4	3	1	+ 4	31
21-25	0	4	5	11	9	4	5	—10	33
26-30	1	5	8	9	8	4	1	—10	34
31-35	4	3	5	4	6	3	5	—13	21
36-40	0	2	8	5	5	3	2	—19	23
41-45	1	2	5	5	4	2	5	—13	18
46-50	0	1	6	2	5	1	5	+ 1	15
51-55	1	4	4	7	9	1	2	— 3	25
56-60	0	1	6	10	12	1	5	+ 5	30
61-65	2	4	5	6	6	3	0	+ 3	24
66-70	0	6	12	15	14	4	1	+ 5	51
71-75	1	9	21	25	13	13	1	+ 4	81
76-80	3	5	17	20	14	5	4	— 1	61
81-85	4	9	20	10	28	7	4	—10	74
86-90	2	6	11	15	17	4	2	—14	53
91-95	1	6	8	3	13	6	2	—38	36
96-100	2	8	3	2	4	5	8	—57	22
Totals . .	23	84	162	167	181	78	54		672

We now return to the mean values, which exhibit the following distinct features:—

(a) A large positive error at about  $=13^{\circ}$ . The values for P and S correspond in almost exactly the ratio 1·80, and thus confirm one another. The observations rejected are:

For P +144<sup>s</sup> and +81<sup>s</sup>. There is no question as regards the former. If the latter be retained the mean is increased to +15<sup>s</sup>. As this group is very important, the errors may be given in full. They are:—

s.	s.	s.	s.	s.
+144	+41	+25	+1	-11
+ 81	+38	+23	0	-13
+ 72	+37	+22	-2	-24
+ 49	+30	+ 7	-6	-37
+ 49	+26	+ 2	-6	-39

For S +131<sup>s</sup> and -102<sup>s</sup> have been rejected. The whole set is as follows:

s.	s.	s.	s.	s.
+131	+45	+29	0	- 32
+ 69	+42	+21	- 2	-102
+ 59	+39	+19	- 9	
+ 55	+34	+15	-17	
+ 46	+30	+12	-29	

It seems clear that the means cannot be far from the values assigned on any reasonable supposition. And it is also clear that the excessive scattering is due to the abrupt rise and fall of the error, which is small in adjoining groups. It must rise to sensibly more than the mean values. The use of the erroneous tables to fix the epicentres will also have tended to diminish these errors by compromise; so that a maximum error for P of +17<sup>s</sup> and for S or +30<sup>s</sup> would not be an unreasonable interpretation of the figures.

(b) The rapid fall to a negative error at about  $\Delta = 23^{\circ}$  continuing to  $\Delta = 40^{\circ}$ . A rise again at  $33^{\circ}$  is shown by P but not by S, and for the present we will disregard it.

(c) A positive error from about  $46^{\circ}$  to  $70^{\circ}$ . This is more marked in P than in S; but it seems possible that S is already affected by the negative error (d), which reduces the positive excess.

(d) A negative error which develops rapidly in S after  $80^{\circ}$ , and may have commenced earlier as remarked in (c). It was this error which chiefly attracted attention in the two former Reports, in which tentative corrections for it were given with some success as regards S. But the corrections suggested for P were apparently too large.

This correction appears to have an important significance. The ratio of times for S to times for P is nearly constant, but with the adopted tables tends to rise in value for large values of  $\Delta$ . When, however, the corrections now found are applied, which diminish the values of S (when  $\Delta > 80^{\circ}$ ) much more than those of P, the rise in value of the ratio disappears, and it seems possible that it is definitely constant and of value 1·800. At any rate, the departures from this

value have all the appearance of accidental errors. They are as follows in units of '001:—

TABLE XXI.

*Differences from the ratio 1'800 for ratio S/P in units of '001.*

$\Delta$	Diff.	$\Delta$	Diff.	$\Delta$	Diff.	$\Delta$	Diff.	$\Delta$	Diff.
13°	- 9	33°	-47	53°	-20	73°	+27	93°	- 7
18	+ 6	38	-12	58	0	78	+17	98	-29
23	+ 1	43	-32	63	- 4	83	+18		
28	+18	48	-38	68	0	88	+ 6		

Of the largest residuals that at  $\Delta = 33^\circ$  is due to the sudden rise of the P residual to  $+1^s$  between two values of  $-11^s$ ; a rise not confirmed by S and probably spurious. The rise of P to  $+8^s$  at  $48^\circ$  also bears the mark of accident. At  $98^\circ$  the correction of  $-57^s$  to the S tables is probably too large. Looking at the residuals in Table XX. we see that they are probably made up of two groups, separated by an interval of at least  $65^s$ . One group, probably the true S, would have a mean correction of  $-57^s + 30^s = -27^s$  say, and the other of  $-57^s - 30^s = -87^s$  say. This latter is probably the Y phenomenon beginning to declare itself. With this interpretation the  $-29$  residual would become  $+7$ .

Hence it may be that we should do well to adopt a constant ratio 1'800, thus strengthening the determinations of both P and S by the tie.

Let us now examine very briefly the values of either P or S near the epicentre. They are clearly affected much in the same way, and one of them will suffice; say P. We may, however, use the values of S, reduced in the ratio 1'80, to strengthen the determination of P. Thus we have:

	$\Delta = 8^\circ$	$13^\circ$	$18^\circ$	$23^\circ$	$28^\circ$	$23^\circ$
Corrected P	$\frac{s.}{118}$	$\frac{s.}{205}$	$\frac{s.}{257}$	$\frac{s.}{308}$	$\frac{s.}{357}$	$\frac{s.}{417}$
From S	122	203	257	308	361	407
Mean	120	204	257	308	359	411
Mean $\delta P$	15'0	16'8	10'6	10'2	10'2	10'4

It seems difficult to avoid a sensible *rise* of the average  $\delta P$  up to  $\Delta = 10^\circ$ . The 16'8 is only an average value, and the maximum must be greater still. This rise in value cannot be explained by any reasonable supposition as to the depth of the focus: for though this provides an initial rise in value, the rise is very slight. We are driven to suppose some important change in density just within the surface of the Earth. We can avoid this supposition in two ways only:—

(a) By discrediting the observations. On this head nothing more need be said: the evidence is before us.

(b) By adding a constant to the whole tables both for P and S.

If we add (say)  $20^{sec}$ , then the mean  $\delta P$  for the first  $8^\circ$  would be  $140^s/8 = 17^s.5$ , greater than the  $16^s.8$  which follows. Even then the

S observations would show a rise: to get rid of the rise in them we should have to add 30<sup>sec</sup>. There are recorded cases of the stoppage of clocks near the epicentre which would be inconsistent with such large corrections to the time at origin.

On the whole, the case for the rise being real seems fairly strong. And now we have to consider how to draw a smooth curve so that these values shall be the means of groups.

Suppose first we join the points by straight lines and let us further omit the point for 13° and join 8° to 18° by a straight line. The value indicated for 13° would be  $\frac{1}{2}(120^s + 257^s) = 189^s$ . Now the observed mean value 204<sup>s</sup> lies 15<sup>s</sup> above this: and this is only the C.G. of the triangle formed by the proper values for 8°, 13°, and 18°. The proper value for the apex of the triangle would be at three times the height; *i.e.*, 30° above the C.G. Thus the proper value for 13°, interpolated between 8° and 18° so as to make a triangle with C.G. at 204<sup>s</sup>, would be 234<sup>s</sup>. The points would then be

8°	13°	18°
<small>s.</small>	<small>s.</small>	<small>s.</small>
120	234	257
Mean $\delta P$		
	<small>s.</small>	<small>s.</small>
	22·8	4·6

We see at once the necessity for a small value of  $\delta P$  following the peak. Now doubtless the peak is not sharp but is rounded off; but note that if we round it off we must at *some* point either increase the large  $\delta P = 22^s \cdot 8$  or decrease the small  $\delta P = 4^s \cdot 6$ ; perhaps both. For any process of rounding off the peak means that we must go outside the triangle to make up the area lost from the peak.

There is thus no difficulty at all about a small value of  $\delta P$  between 13° and 18°; indeed, it is almost a necessity. And hence the PX phenomenon can probably be explained. The small value of  $\delta P$  comes earlier than was suggested in Table V.: but it seems probable that by some little adjustment the phenomena may be all brought into line. The reason why the sudden drop was assumed to come later was the avoidance of the rise in  $\delta P$  near the epicentre. It seemed theoretically probable that the velocity near the epicentre was nearly constant, and thus, in order to accumulate a fund of positive errors before the drop,  $\delta P$  had to be carried on at the highest available value for some distance. Once the possibility of a rise in  $\delta P$  near the epicentre is admitted and the drop may come earlier. But the initial rise in  $\delta P$  is distinctly surprising, though the observations seem to leave no room for doubt.



*The Calculation of Mathematical Tables.*—*Report of the Committee, consisting of Professor M. J. M. HILL (Chairman), Professor J. W. NICHOLSON (Secretary), Dr. J. R. AIREY, Mr. T. W. CHAUNDY, Mr. A. T. DOODSON, Professor L. N. G. FILON, Mr. G. KENNEDY, Sir GEORGE GREENHILL, Professors E. W. HOBSON, ALFRED LODGE, A. E. H. LOVE, H. M. MACDONALD, and G. B. MATHEWS, Mr. H. G. SAVIDGE, and Professor A. G. WEBSTER.*

### *Introductory.*

THE grant of 35*l.*—including 5*l.* returned as the unexpended part of the previous grant—has been utilised completely during the present year, and the Committee is able to put forward several completed Tables for which there has been a considerable demand among physicists, as evidenced by written requests to the Secretary. Some other Tables, not at present complete, are still in hand, and it is proposed during the coming year to devote more attention to the roots of Bessel functions which are needed for the solution of physical problems. The Committee desires to ask for a renewal of the grant of 30*l.*, especially in view of the fact that their expenditure has exceeded the former grant, on account of the simultaneous completion of several different Tables. The Report may be divided into five Parts. In Part I. there are three Tables of sines and cosines of angles expressed in circular measure. The main purpose of such Tables is to facilitate the rapid calculation of transcendental functions from their asymptotic expansions. They have been the subject of special approval by the Association. Tables I. and II. have been under the care of Dr. Airey, and Table III. of Mr. Doodson.

Part II. deals with the Bessel and Neumann functions whose order and argument are nearly equal. Dr. Airey, to whom they are due, has recently extended the formulæ of Nicholson and Debye relating to these functions, which are now somewhat prominent in physical work.

In Part III. Mr. Doodson continues his Tables of Bessel functions of half-integral order, and some of their derived functions. These Tables are a continuation of those in the Report for 1914.

Part IV. continues the work of Mr. Savidge on Tables of the *ber* and *bei* functions and their derivatives.

Part V. contains some valuable Tables of the logarithmic Gamma function and its derivative, together with the integral of the function. These have been calculated and kindly offered to the Association by Prof. G. N. Watson. In recording their appreciation, the Committee desires to suggest that Prof. Watson should be added to their number.

### PART I.

#### *Sines and Cosines of Angles in Circular Measure.*

The trigonometrical functions, especially the sines and cosines of angles expressed in radians, are of frequent occurrence in the asymptotic expansions of transcendental functions. The only tables hitherto published are

those of Burrau<sup>1</sup> to six places, and those of Becker and Van Orstrand<sup>2</sup> to five places of decimals from  $\theta=0.001$  to 1.600 radians.

The following tables to ten places of decimals were calculated to thirteen places, first for the sixteen values 0.1 to 1.6, then from 0.01 to 1.60, and finally from 0.001 to 1.600. From the values of the sine and cosine of 0.1 to 1.6, intermediate values were obtained by employing the sum and difference formulæ of these functions: the results were taken from 0.00 to 0.05 and from 0.10 to 0.05 and thus furnished a check upon the calculations. A similar procedure was followed in calculating the sines and cosines when  $\theta$  is given to three places of decimals. In order to ensure greater accuracy in the tenth place, the next figure is also given. In very few cases will the error reach a unit in the eleventh place. The subsidiary table of sines and cosines of  $\theta$  from  $\theta=0.00001$  to  $\theta=0.00100$  can be employed in conjunction with the first table.

TABLE I.  
*Tables of Sines and Cosines ( $\theta$  in radians).*

$\theta$	Sin $\theta$			Cos $\theta$		
0.000	.00000	00000	0	1.00000	00000	0
0.001	.00099	99998	3	.99999	95000	0
0.002	.00199	99986	7	.99999	80000	0
0.003	.00299	99955	0	.99999	55000	0
0.004	.00399	99893	3	.99999	20000	1
0.005	.00499	99791	7	.99998	75000	2
0.006	.00599	99640	0	.99998	20000	5
0.007	.00699	99428	3	.99997	55001	0
0.008	.00799	99146	7	.99996	80001	7
0.009	.00899	98785	0	.99995	95002	7
0.010	.00999	98333	3	.99995	00004	2
0.011	.01099	97781	7	.99993	95006	1
0.012	.01199	97120	0	.99992	80008	6
0.013	.01299	96338	4	.99991	55011	9
0.014	.01399	95426	7	.99990	20016	0
0.015	.01499	94375	1	.99988	75021	1
0.016	.01599	93173	4	.99987	20027	3
0.017	.01699	91811	8	.99985	55034	8
0.018	.01799	90280	2	.99983	80043	7
0.019	.01899	88568	5	.99981	95054	3
0.020	.01999	86666	9	.99980	00066	7
0.021	.02099	84565	3	.99977	95081	0
0.022	.02199	82253	8	.99975	80097	6
0.023	.02299	79722	2	.99973	55116	6
0.024	.02399	76960	7	.99971	20138	2
0.025	.02499	73959	2	.99968	75162	7
0.026	.02599	70707	7	.99966	20190	4
0.027	.02699	67196	2	.99963	55221	4
0.028	.02799	63414	8	.99960	80256	1
0.029	.02899	59353	4	.99957	95294	7
0.030	.02999	55002	0	.99955	00337	5
0.031	.03099	50350	7	.99951	95384	8
0.032	.03199	45389	5	.99948	80436	9
0.033	.03299	40108	3	.99945	55494	1
0.034	.03399	34497	1	.99942	20556	8

<sup>1</sup> Burrau, *Tafeln der Funktionen Cosinus und Sinus*, 1907.

<sup>2</sup> Becker and Van Orstrand, *Smithsonian Mathematical Tables*, Hyperbolic Functions, pp. 174-223.

Tables of Sines and Cosines ( $\theta$  in radians)—continued.

$\theta$	Sin $\theta$	Cos $\theta$
0.035	·03499 28546 0	·99938 75625 2
0.036	·03599 22245 0	·99935 20699 8
0.037	·03699 15584 1	·99931 55780 9
0.038	·03799 08553 3	·99927 80868 8
0.039	·03899 01142 5	·99923 95963 9
0.040	·03998 93341 9	·99920 01066 6
0.041	·04098 85141 3	·99915 96177 3
0.042	·04198 76530 9	·99911 81296 5
0.043	·04298 67500 6	·99907 56424 4
0.044	·04398 58040 4	·99903 21561 6
0.045	·04498 48140 4	·99898 76708 5
0.046	·04598 37790 5	·99894 21865 5
0.047	·04698 26980 8	·99889 57033 0
0.048	·04798 15701 2	·99884 82211 7
0.049	·04898 03941 9	·99879 97401 8
0.050	·04997 91692 7	·99875 02604 0
0.051	·05097 78943 8	·99869 97818 6
0.052	·05197 65685 0	·99864 83046 2
0.053	·05297 51906 5	·99859 58287 4
0.054	·05397 37598 3	·99854 23542 6
0.055	·05497 22750 3	·99848 78812 4
0.056	·05597 07352 6	·99843 24097 3
0.057	·05696 91395 1	·99837 59397 9
0.058	·05796 74868 0	·99831 84714 7
0.059	·05896 57761 2	·99826 00048 3
0.060	·05996 40064 8	·99820 05399 4
0.061	·06096 21768 7	·99814 00768 4
0.062	·06196 02863 0	·99807 86156 0
0.063	·06295 83337 7	·99801 61562 9
0.064	·06395 63182 8	·99795 26989 5
0.065	·06495 42388 3	·99788 82436 7
0.066	·06595 20944 3	·99782 27905 0
0.067	·06694 98840 8	·99775 63395 0
0.068	·06794 76067 8	·99768 88907 5
0.069	·06894 52615 3	·99762 04443 1
0.070	·06994 28473 4	·99755 10002 5
0.071	·07094 03632 0	·99748 05586 4
0.072	·07193 78081 2	·99740 91195 5
0.073	·07293 51811 1	·99733 66830 5
0.074	·07393 24811 6	·99726 32492 1
0.075	·07492 97072 7	·99718 88181 1
0.076	·07592 68584 6	·99711 33898 2
0.077	·07692 39337 2	·99703 69644 2
0.078	·07792 09320 6	·99695 95419 8
0.079	·07891 78524 7	·99688 11225 8
0.080	·07991 46939 7	·99680 17063 0
0.081	·08091 14555 5	·99672 12932 2
0.082	·08190 81362 2	·99663 98834 2
0.083	·08290 47349 9	·99655 74769 8
0.084	·08390 12508 5	·99647 40739 8
0.085	·08489 76828 0	·99638 96745 0
0.086	·08589 40298 6	·99630 42786 4
0.087	·08689 02910 3	·99621 78864 7
0.088	·08788 64653 0	·99613 04980 9
0.089	·08888 25516 9	·99604 21135 7
0.090	·08987 85492 0	·99595 27330 1
0.091	·09087 44568 3	·99586 23565 0
0.092	·09187 02735 8	·99577 09841 3

Tables of Sines and Cosines ( $\theta$  in radians)—continued.

$\theta$	Sin $\theta$	Cos $\theta$
0.093	·09286 59984 6	·99567 86159 8
0.094	·09386 16304 8	·99558 52521 6
0.095	·09485 71686 3	·99549 08927 5
0.096	·09585 26119 3	·99539 55378 6
0.097	·09684 79593 8	·99529 91875 6
0.098	·09784 32099 8	·99520 18419 7
0.099	·09883 83627 3	·99510 35011 8
0.100	·09983 34166 5	·99500 41652 8
0.101	·10082 83707 3	·99490 38343 8
0.102	·10182 32239 8	·99480 25085 7
0.103	·10281 79754 2	·99470 01879 6
0.104	·10381 26240 3	·99459 68726 5
0.105	·10480 71688 3	·99449 25627 5
0.106	·10580 16088 2	·99438 72583 5
0.107	·10679 59430 1	·99428 09595 7
0.108	·10779 01704 1	·99417 36665 0
0.109	·10878 42900 2	·99406 53792 6
0.110	·10977 83008 4	·99395 60979 6
0.111	·11077 22018 8	·99384 58227 0
0.112	·11176 59921 5	·99373 45535 9
0.113	·11275 96706 6	·99362 22907 5
0.114	·11375 32364 0	·99350 90342 9
0.115	·11474 66883 9	·99339 47843 1
0.116	·11574 00256 4	·99327 95409 5
0.117	·11673 32471 4	·99316 33043 0
0.118	·11772 63519 2	·99304 60744 9
0.119	·11871 93389 6	·99292 78516 4
0.120	·11971 22072 9	·99280 86358 5
0.121	·12070 49559 0	·99268 84272 6
0.122	·12169 75838 1	·99256 72259 8
0.123	·12269 00900 2	·99244 50321 3
0.124	·12368 24735 5	·99232 18458 4
0.125	·12467 47333 9	·99219 76672 3
0.126	·12566 68685 5	·99207 24964 2
0.127	·12665 88780 5	·99194 63335 3
0.128	·12765 07608 9	·99181 91787 0
0.129	·12864 25160 7	·99169 10320 5
0.130	·12963 41426 2	·99156 18937 1
0.131	·13062 56395 3	·99143 17638 1
0.132	·13161 70058 2	·99130 06424 8
0.133	·13260 82404 9	·99116 85298 4
0.134	·13359 93425 5	·99103 54260 4
0.135	·13459 03110 1	·99090 13312 0
0.136	·13558 11448 8	·99076 62454 6
0.137	·13657 18431 7	·99063 01689 6
0.138	·13756 24048 9	·99049 31018 2
0.139	·13855 28290 4	·99035 50442 0
0.140	·13954 31146 4	·99021 59962 1
0.141	·14053 32607 0	·99007 59580 1
0.142	·14152 32662 3	·98993 49297 4
0.143	·14251 31302 3	·98979 29115 3
0.144	·14350 28517 2	·98964 99035 2
0.145	·14449 24297 1	·98950 59058 7
0.146	·14548 18632 1	·98936 09187 1
0.147	·14647 11512 2	·98921 49421 9
0.148	·14746 02927 6	·98906 79764 6
0.149	·14844 92868 4	·98892 00216 6
0.150	·14943 81324 7	·98877 10779 4

Tables of Sines and Cosines ( $\theta$  in radians)—continued.

$\theta$	Sin $\theta$	Cos $\theta$
0.151	•15042 68286 7	•98862 11454 4
0.152	•15141 53744 3	•98847 02243 3
0.153	•15240 37687 9	•98831 83147 4
0.154	•15339 20107 3	•98816 54168 4
0.155	•15438 00992 9	•98801 15307 7
0.156	•15536 80334 7	•98785 66566 9
0.157	•15635 58122 7	•98770 07947 6
0.158	•15734 34347 3	•98754 39451 2
0.159	•15833 08998 4	•98738 61079 4
0.160	•15931 82066 1	•98722 72833 8
0.161	•16030 53540 7	•98706 74715 8
0.162	•16129 23412 3	•98690 66727 2
0.163	•16227 91670 9	•98674 48869 5
0.164	•16326 58306 7	•98658 21144 4
0.165	•16425 23309 9	•98641 83553 5
0.166	•16523 86670 6	•98625 36098 3
0.167	•16622 48378 8	•98608 78780 7
0.168	•16721 08424 8	•98592 11602 1
0.169	•16819 66798 7	•98575 34564 4
0.170	•16918 23490 7	•98558 47669 1
0.171	•17016 78490 8	•98541 50918 0
0.172	•17115 31789 2	•98524 44312 7
0.173	•17213 83376 1	•98507 27855 0
0.174	•17312 33241 6	•98490 01546 5
0.175	•17410 81375 9	•98472 65389 0
0.176	•17509 27769 1	•98455 19384 3
0.177	•17607 72411 4	•98437 63534 1
0.178	•17706 15292 9	•98419 97840 1
0.179	•17804 56403 8	•98402 22304 1
0.180	•17902 95734 3	•98384 36927 9
0.181	•18001 33274 4	•98366 41713 2
0.182	•18099 69014 4	•98348 36661 9
0.183	•18198 02944 4	•98330 21775 8
0.184	•18296 35054 7	•98311 97056 6
0.185	•18394 65335 3	•98293 62506 3
0.186	•18492 93776 4	•98275 18126 6
0.187	•18591 20368 3	•98256 63919 4
0.188	•18689 45101 0	•98237 99886 5
0.189	•18787 67964 8	•98219 26029 8
0.190	•18885 88949 8	•98200 42351 2
0.191	•18984 08046 2	•98181 48852 5
0.192	•19082 25244 2	•98162 45535 7
0.193	•19180 40534 0	•98143 32402 7
0.194	•19278 53905 7	•98124 09455 3
0.195	•19376 65349 6	•98104 76695 5
0.196	•19474 74855 9	•98085 34125 2
0.197	•19572 82414 6	•98065 81746 4
0.198	•19670 88016 1	•98046 19561 1
0.199	•19768 91650 5	•98026 47571 1
0.200	•19866 93307 9	•98006 65778 4
0.201	•19964 92978 7	•97986 74185 1
0.202	•20062 90653 1	•97966 72793 1
0.203	•20160 86321 1	•97946 61604 5
0.204	•20258 79973 0	•97926 40621 1
0.205	•20356 71599 0	•97906 09845 2
0.206	•20454 61189 4	•97885 69278 6
0.207	•20552 48734 3	•97865 18923 5
0.208	•20650 34224 0	•97844 58781 8

Tables of Sines and Cosines ( $\theta$  in radians)—continued.

$\theta$	Sin $\theta$			Cos $\theta$		
0.209	.20748	17648	6	.97823	88855	7
0.210	.20845	98998	5	.97803	09147	2
0.211	.20943	78263	7	.97782	19658	4
0.212	.21041	55434	5	.97761	20391	4
0.213	.21139	30501	2	.97740	11348	3
0.214	.21237	03454	0	.97718	92531	1
0.215	.21334	74283	0	.97697	63942	1
0.216	.21432	42978	6	.97676	25583	3
0.217	.21530	09530	9	.97654	77456	8
0.218	.21627	73930	2	.97633	19564	9
0.219	.21725	36166	8	.97611	51909	7
0.220	.21822	96230	8	.97589	74493	3
0.221	.21920	54112	5	.97567	87318	0
0.222	.22018	09802	2	.97545	90385	8
0.223	.22115	63290	0	.97523	83699	1
0.224	.22213	14566	3	.97501	67260	0
0.225	.22310	63621	3	.97479	41070	7
0.226	.22408	10445	2	.97457	05133	5
0.227	.22505	55028	3	.97434	59450	5
0.228	.22602	97360	9	.97412	04024	2
0.229	.22700	37433	1	.97389	38856	6
0.230	.22797	75235	4	.97366	63950	1
0.231	.22895	10757	8	.97343	79306	9
0.232	.22992	43990	7	.97320	84929	3
0.233	.23089	74924	4	.97297	80819	6
0.234	.23187	03549	1	.97274	66980	2
0.235	.23284	29855	1	.97251	43413	3
0.236	.23381	53832	7	.97228	10121	3
0.237	.23478	75472	1	.97204	67106	4
0.238	.23575	94763	7	.97181	14371	1
0.239	.23673	11697	6	.97157	51917	7
0.240	.23770	26264	3	.97133	79748	5
0.241	.23867	38453	9	.97109	97866	0
0.242	.23964	48256	8	.97086	06272	4
0.243	.24061	55663	2	.97062	04970	2
0.244	.24158	60663	5	.97037	93961	9
0.245	.24255	63247	9	.97013	73249	7
0.246	.24352	63406	7	.96989	42836	2
0.247	.24449	61130	3	.96965	02723	7
0.248	.24546	56408	9	.96940	52914	7
0.249	.24643	49232	9	.96915	93411	7
0.250	.24740	39592	5	.96891	24217	1
0.251	.24837	27478	1	.96866	45333	4
0.252	.24934	12880	0	.96841	56763	0
0.253	.25030	95788	4	.96816	58508	4
0.254	.25127	76193	8	.96791	50572	2
0.255	.25224	54086	3	.96766	32956	9
0.256	.25321	29456	5	.96741	05664	9
0.257	.25418	02294	4	.96715	68698	8
0.258	.25514	72590	6	.96690	22061	2
0.259	.25611	40335	3	.96664	65754	5
0.260	.25708	05518	9	.96638	99781	3
0.261	.25804	68131	7	.96613	24144	3
0.262	.25901	28164	0	.96587	38845	9
0.263	.25997	85606	2	.96561	43888	8
0.264	.26094	40448	5	.96535	39275	6
0.265	.26190	92681	5	.96509	25008	8
0.266	.26287	42295	3	.96483	01091	1

Tables of Sines and Cosines ( $\theta$  in radians)—continued.

$\theta$	Sin $\theta$			Cos $\theta$		
0.267	.26383	89280	5	.96456	67525	1
0.268	.26480	33627	2	.96430	24313	4
0.269	.26576	75325	9	.96403	71458	7
0.270	.26673	14366	9	.96377	08963	7
0.271	.26769	50740	6	.96350	36830	9
0.272	.26865	84437	3	.96323	55063	1
0.273	.26962	15447	5	.96296	63662	9
0.274	.27058	43761	5	.96269	62633	1
0.275	.27154	69369	6	.96242	51976	3
0.276	.27250	92262	2	.96215	31695	2
0.277	.27347	12429	7	.96188	01792	7
0.278	.27443	29862	6	.96160	62271	3
0.279	.27539	44551	1	.96133	13133	9
0.280	.27635	56485	6	.96105	54383	1
0.281	.27731	65656	6	.96077	86021	8
0.282	.27827	72054	5	.96050	08052	7
0.283	.27923	75669	5	.96022	20478	6
0.284	.28019	76492	2	.95994	23302	3
0.285	.28115	74512	9	.95966	16526	6
0.286	.28211	69722	1	.95938	00154	2
0.287	.28307	62110	1	.95909	74188	1
0.288	.28403	51667	3	.95881	38630	9
0.289	.28499	38384	1	.95852	93485	7
0.290	.28595	22251	0	.95824	38755	1
0.291	.28691	03258	4	.95795	74442	1
0.292	.28786	81396	7	.95767	00549	6
0.293	.28882	56656	3	.95738	17080	3
0.294	.28978	29027	7	.95709	24037	2
0.295	.29073	98501	2	.95680	21423	2
0.296	.29169	65067	4	.95651	09241	2
0.297	.29265	28716	5	.95621	87494	0
0.298	.29360	89439	2	.95592	56184	7
0.299	.29456	47225	7	.95563	15316	1
0.300	.29552	02066	6	.95533	64891	3
0.301	.29647	53952	3	.95504	04913	0
0.302	.29743	02873	3	.95474	35384	3
0.303	.29838	48819	9	.95444	56308	2
0.304	.29933	91782	7	.95414	67687	7
0.305	.30029	31752	1	.95384	69525	7
0.306	.30124	68718	6	.95354	61825	2
0.307	.30220	02672	6	.95324	44589	2
0.308	.30315	33604	6	.95294	17820	9
0.309	.30410	61505	0	.95263	81523	0
0.310	.30505	86364	4	.95233	35698	9
0.311	.30601	08173	3	.95202	80351	3
0.312	.30696	26922	0	.95172	15483	5
0.313	.30791	42601	0	.95141	41098	5
0.314	.30886	55201	0	.95110	57199	3
0.315	.30981	64712	3	.95079	63789	1
0.316	.31076	71125	4	.95048	60871	0
0.317	.31171	74430	8	.95017	48447	9
0.318	.31266	74619	1	.94986	26523	1
0.319	.31361	71680	7	.94954	95099	7
0.320	.31456	65606	2	.94923	54180	8
0.321	.31551	56385	9	.94892	03769	6
0.322	.31646	44010	5	.94860	43869	1
0.323	.31741	28470	5	.94828	74482	6
0.324	.31836	09756	3	.94796	95613	2

Tables of Sines and Cosines ( $\theta$  in radians)—continued.

$\theta$	Sin $\theta$	Cos $\theta$
0.325	·31930 87858 6	·94765 07264 1
0.326	·32025 62767 7	·94733 09438 6
0.327	·32120 34474 3	·94701 02139 7
0.328	·32215 02968 8	·94668 85370 7
0.329	·32309 68241 9	·94636 59134 8
0.330	·32404 30283 9	·94604 23435 3
0.331	·32498 89085 6	·94571 78275 3
0.332	·32593 44637 3	·94539 23658 2
0.333	·32687 96929 8	·94506 59587 1
0.334	·32782 45953 4	·94473 86065 4
0.335	·32876 91698 7	·94441 03096 3
0.336	·32971 34156 4	·94408 10683 1
0.337	·33065 73317 0	·94375 08829 1
0.338	·33160 09170 9	·94341 97537 6
0.339	·33254 41708 9	·94308 76811 9
0.340	·33348 70921 4	·94275 46655 3
0.341	·33442 96799 1	·94242 07071 1
0.342	·33537 19332 4	·94208 58062 8
0.343	·33631 38512 0	·94174 99633 6
0.344	·33725 54328 5	·94141 31786 9
0.345	·33819 66772 5	·94107 54526 1
0.346	·33913 75834 4	·94073 67854 5
0.347	·34007 81505 0	·94039 71775 5
0.348	·34101 83774 9	·94005 66292 6
0.349	·34195 82634 5	·93971 51409 1
0.350	·34289 78074 6	·93937 27128 5
0.351	·34383 70085 6	·93902 93454 1
0.352	·34477 58658 3	·93868 50389 4
0.353	·34571 43783 3	·93833 97937 9
0.354	·34665 25451 1	·93799 36103 0
0.355	·34759 03652 3	·93764 64888 2
0.356	·34852 78377 7	·93729 84296 9
0.357	·34946 49617 8	·93694 94332 6
0.358	·35040 17363 3	·93659 94998 8
0.359	·35133 81604 7	·93624 86299 0
0.360	·35227 42332 7	·93589 68236 8
0.361	·35320 99538 1	·93554 40815 5
0.362	·35414 53211 3	·93519 04038 9
0.363	·35508 03343 0	·93483 57910 3
0.364	·35601 49924 0	·93448 02433 4
0.365	·35694 92944 8	·93412 37611 6
0.366	·35788 32396 1	·93376 63448 7
0.367	·35881 68268 5	·93340 79948 0
0.368	·35975 00552 9	·93304 87113 3
0.369	·36068 29239 7	·93268 84948 1
0.370	·36161 54319 6	·93232 73456 1
0.371	·36254 75783 5	·93196 52640 7
0.372	·36347 93621 8	·93160 22505 7
0.373	·36441 07825 4	·93123 83054 7
0.374	·36534 18384 8	·93087 34291 3
0.375	·36627 25290 9	·93050 76219 1
0.376	·36720 28534 2	·93014 08841 9
0.377	·36813 28105 4	·92977 32163 3
0.378	·36906 23995 4	·92940 46186 9
0.379	·36999 16194 7	·92903 50916 5
0.380	·37092 04694 1	·92866 46355 8
0.381	·37184 89484 3	·92829 32508 4
0.382	·37277 70556 0	·92792 09378 0



Tables of Sines and Cosines ( $\theta$  in radians)—continued.

$\theta$	Sin $\theta$			Cos $\theta$		
0.383	·37370	47900	0	·92754	76968	5
0.384	·37463	21506	9	·92717	35283	5
0.385	·37555	91367	5	·92679	84326	7
0.386	·37648	57472	5	·92642	24102	0
0.387	·37741	19812	6	·92604	54613	0
0.388	·37833	78378	6	·92566	75863	6
0.389	·37926	33161	2	·92528	87857	5
0.390	·38018	84151	2	·92490	90598	6
0.391	·38111	31339	3	·92452	84090	5
0.392	·38203	74716	3	·92414	68337	2
0.393	·38296	14272	9	·92376	43342	4
0.394	·38388	49999	9	·92338	09109	9
0.395	·38480	81888	1	·92299	65643	6
0.396	·38573	09928	1	·92261	12947	4
0.397	·38665	34110	9	·92222	51025	1
0.398	·38757	54427	1	·92183	79880	5
0.399	·38849	70867	6	·92144	99517	5
0.400	·38941	83423	1	·92106	09940	0
0.401	·39033	92084	4	·92067	11152	0
0.402	·39125	96842	3	·92028	03157	2
0.403	·39217	97687	6	·91988	85959	6
0.404	·39309	94611	2	·91949	59563	1
0.405	·39401	87603	7	·91910	23971	7
0.406	·39493	76656	0	·91870	79189	2
0.407	·39585	61759	0	·91831	25219	7
0.408	·39677	42903	4	·91791	62067	0
0.409	·39769	20080	1	·91751	89735	2
0.410	·39860	93279	8	·91712	08228	2
0.411	·39952	62493	5	·91672	17549	9
0.412	·40044	27711	9	·91632	17704	5
0.413	·40135	88925	8	·91592	08695	9
0.414	·40227	46126	2	·91551	90528	0
0.415	·40318	99303	8	·91511	63204	9
0.416	·40410	48449	6	·91471	26730	7
0.417	·40501	93554	3	·91430	81109	4
0.418	·40593	34608	8	·91390	26345	0
0.419	·40684	71603	9	·91349	62441	5
0.420	·40776	04530	6	·91308	89403	1
0.421	·40867	33379	7	·91268	07233	8
0.422	·40958	58142	0	·91227	15937	7
0.423	·41049	78808	5	·91186	15518	9
0.424	·41140	95370	0	·91145	05981	5
0.425	·41232	07817	4	·91103	87329	5
0.426	·41323	16141	6	·91062	59567	2
0.427	·41414	20333	5	·91021	22698	6
0.428	·41505	20384	0	·90979	76727	9
0.429	·41596	16284	0	·90938	21659	3
0.430	·41687	08024	3	·90896	57496	8
0.431	·41777	95595	9	·90854	84244	6
0.432	·41868	78989	7	·90813	01907	0
0.433	·41959	58196	7	·90771	10488	0
0.434	·42050	33207	7	·90729	09992	0
0.435	·42141	04013	7	·90687	00423	0
0.436	·42231	70605	5	·90644	81785	3
0.437	·42322	32974	2	·90602	54083	2
0.438	·42412	91110	7	·90560	17320	8
0.439	·42503	45005	8	·90517	71502	4
0.440	·42593	94650	7	·90475	16632	2

Tables of Sines and Cosines ( $\theta$  in radians)—continued.

$\theta$	Sin $\theta$	Cos $\theta$
0.441	.42684 40036 1	.90432 52714 5
0.442	.42774 81153 1	.90389 79753 6
0.443	.42865 17992 6	.90346 97753 6
0.444	.42955 50545 6	.90304 06719 0
0.445	.43045 78803 0	.90261 06654 0
0.446	.43136 02755 9	.90217 97562 8
0.447	.43226 22395 1	.90174 79449 9
0.448	.43316 37711 8	.90131 52319 5
0.449	.43406 48696 8	.90088 16175 9
0.450	.43496 55341 1	.90044 71023 5
0.451	.43586 57635 8	.90001 16866 7
0.452	.43676 55571 8	.89957 53709 7
0.453	.43766 49140 2	.89913 81557 0
0.454	.43856 38332 0	.89870 00412 9
0.455	.43946 23138 0	.89826 10281 8
0.456	.44036 03549 5	.89782 11168 1
0.457	.44125 79557 4	.89738 03076 2
0.458	.44215 51152 7	.89693 86010 4
0.459	.44305 18326 4	.89649 59975 3
0.460	.44394 81069 7	.89605 24975 3
0.461	.44484 39373 4	.89560 81014 7
0.462	.44573 93228 7	.89516 28098 0
0.463	.44663 42626 6	.89471 66229 7
0.464	.44752 87558 2	.89426 95414 2
0.465	.44842 28014 5	.89382 15656 1
0.466	.44931 63986 5	.89337 26959 7
0.467	.45020 95465 4	.89292 29329 6
0.468	.45110 22442 2	.89247 22770 3
0.469	.45199 44908 0	.89202 07286 2
0.470	.45288 62853 8	.89156 82882 0
0.471	.45377 76270 8	.89111 49562 0
0.472	.45466 85149 9	.89066 07330 9
0.473	.45555 89482 5	.89020 56193 2
0.474	.45644 89259 4	.88974 96153 5
0.475	.45733 84471 8	.88929 27216 2
0.476	.45822 75110 8	.88883 49386 0
0.477	.45911 61167 6	.88837 62667 5
0.478	.46000 42633 2	.88791 67065 2
0.479	.46089 19498 8	.88745 62583 8
0.480	.46177 91755 4	.88699 49227 8
0.481	.46266 59394 3	.88653 27001 8
0.482	.46355 22406 5	.88606 95910 5
0.483	.46443 80783 1	.88560 55958 6
0.484	.46532 34515 4	.88514 07150 5
0.485	.46620 83594 5	.88467 49491 1
0.486	.46709 28011 5	.88420 82984 9
0.487	.46797 67757 5	.88374 07636 6
0.488	.46886 02823 8	.88327 23450 9
0.489	.46974 33201 5	.88280 30432 5
0.490	.47062 58881 7	.88233 28586 1
0.491	.47150 79855 7	.88186 17916 3
0.492	.47238 96114 6	.88138 98428 0
0.493	.47327 07649 6	.88091 70125 7
0.494	.47415 14451 9	.88044 33014 2
0.495	.47503 16512 7	.87996 87098 4
0.496	.47591 13823 2	.87949 32382 8
0.497	.47679 06374 5	.87901 68872 3
0.498	.47766 94158 0	.87853 96571 6

Tables of Sines and Cosines ( $\theta$  in radians)—continued.

$\theta$	Sin $\theta$	Cos $\theta$
0.499	·47854 77164 8	·87806 15485 6
0.500	·47942 55386 0	·87758 25618 9
0.501	·48030 28813 1	·87710 26976 4
0.502	·48117 97437 1	·87662 19562 9
0.503	·48205 61249 3	·87614 03383 1
0.504	·48293 20240 9	·87565 78442 0
0.505	·48380 74403 2	·87517 44744 3
0.506	·48468 23727 5	·87469 02294 8
0.507	·48555 68204 9	·87420 51098 4
0.508	·48643 07826 8	·87371 91160 0
0.509	·48730 42584 3	·87323 22484 4
0.510	·48817 72468 8	·87274 45076 5
0.511	·48904 97471 6	·87225 58941 1
0.512	·48992 17583 8	·87176 64083 1
0.513	·49079 32796 8	·87127 60507 5
0.514	·49166 43101 9	·87078 48219 2
0.515	·49253 48490 4	·87029 27223 0
0.516	·49340 48953 5	·86979 97523 8
0.517	·49427 44482 5	·86930 59126 7
0.518	·49514 35068 8	·86881 12036 5
0.519	·49601 20703 7	·86831 56258 2
0.520	·49688 01378 4	·86781 91796 8
0.521	·49774 77084 4	·86732 18657 1
0.522	·49861 47812 9	·86682 36844 3
0.523	·49948 13555 2	·86632 46363 2
0.524	·50034 74302 7	·86582 47218 8
0.525	·50121 30046 7	·86532 39416 2
0.526	·50207 80778 6	·86482 22960 4
0.527	·50294 26489 8	·86431 97856 3
0.528	·50380 67171 5	·86381 64109 1
0.529	·50467 02815 1	·86331 21723 7
0.530	·50553 33412 0	·86280 70705 1
0.531	·50639 58953 6	·86230 11058 5
0.532	·50725 79431 3	·86179 42788 9
0.533	·50811 94836 4	·86128 65901 4
0.534	·50898 05160 2	·86077 80400 9
0.535	·50984 10394 3	·86026 86292 7
0.536	·51070 10529 9	·85975 83581 9
0.537	·51156 05558 6	·85924 72273 4
0.538	·51241 95471 6	·85873 52372 4
0.539	·51327 80260 5	·85822 23884 2
0.540	·51413 59916 5	·85770 86813 6
0.541	·51499 34431 2	·85719 41160 6
0.542	·51585 03796 0	·85667 86946 5
0.543	·51670 68002 3	·85616 24160 2
0.544	·51756 27041 5	·85564 52812 2
0.545	·51841 80905 0	·85512 72907 8
0.546	·51927 29584 4	·85460 84452 1
0.547	·52012 73071 1	·85408 87450 4
0.548	·52098 11356 5	·85356 81907 7
0.549	·52183 44432 1	·85304 67829 4
0.550	·52268 72289 3	·85252 45220 6
0.551	·52353 94919 7	·85200 14086 6
0.552	·52439 12314 6	·85147 74432 5
0.553	·52524 24465 7	·85095 26263 7
0.554	·52609 31364 3	·85042 69585 3
0.555	·52694 33002 0	·84990 04402 7
0.556	·52779 29370 3	·84937 30721 1

*Tables of Sines and Cosines ( $\theta$  in radians)—continued.*

$\theta$	Sin $\theta$	Cos $\theta$
0.557	.52864 20460 6	.84884 48545 7
0.558	.52949 06264 6	.84831 57881 9
0.559	.53033 86773 6	.84778 58735 0
0.560	.53118 61979 2	.84725 51110 1
0.561	.53203 31873 0	.84672 35012 8
0.562	.53287 96446 4	.84619 10448 2
0.563	.53372 55691 0	.84565 77421 6
0.564	.53457 09598 4	.84512 35938 6
0.565	.53541 58160 1	.84458 86004 2
0.566	.53626 01367 6	.84405 27624 0
0.567	.53710 39212 5	.84351 60803 3
0.568	.53794 71686 4	.84297 85547 4
0.569	.53878 98780 8	.84244 01861 7
0.570	.53963 20487 3	.84190 09751 6
0.571	.54047 36797 5	.84136 09222 5
0.572	.54131 47703 0	.84082 00279 8
0.573	.54215 53195 3	.84027 82928 9
0.574	.54299 53266 0	.83973 57175 2
0.575	.54383 47906 8	.83919 23024 2
0.576	.54467 37109 3	.83864 80481 2
0.577	.54551 20865 0	.83810 29551 8
0.578	.54634 99165 6	.83755 70241 3
0.579	.54718 72002 7	.83701 02555 3
0.580	.54802 39367 9	.83646 26499 2
0.581	.54886 01252 9	.83591 42078 4
0.582	.54969 57649 3	.83536 49298 5
0.583	.55053 08548 7	.83481 48164 9
0.584	.55136 53942 8	.83426 38683 2
0.585	.55219 93823 3	.83371 20858 9
0.586	.55303 28181 8	.83315 94697 4
0.587	.55386 57009 9	.83260 60204 3
0.588	.55469 80299 4	.83205 17385 2
0.589	.55552 98041 9	.83149 66245 6
0.590	.55636 10229 1	.83094 06791 0
0.591	.55719 16852 7	.83038 39027 0
0.592	.55802 17904 4	.82982 62959 2
0.593	.55885 13375 9	.82926 78593 0
0.594	.55968 03258 8	.82870 85934 3
0.595	.56050 87545 0	.82814 84988 4
0.596	.56133 66226 0	.82758 75761 0
0.597	.56216 39293 7	.82702 58257 8
0.598	.56299 06739 8	.82646 32484 3
0.599	.56381 68556 0	.82589 98446 2
0.600	.56464 24733 9	.82533 56149 1
0.601	.56546 75265 5	.82477 05598 6
0.602	.56629 20142 4	.82420 46800 4
0.603	.56711 59356 4	.82363 79760 2
0.604	.56793 92899 2	.82307 04483 6
0.605	.56876 20762 6	.82250 20976 3
0.606	.56958 42938 4	.82193 29244 0
0.607	.57040 59418 3	.82136 29292 3
0.608	.57122 70194 2	.82079 21127 1
0.609	.57204 75257 9	.82022 04753 9
0.610	.57286 74601 0	.81964 80178 5
0.611	.57368 68215 5	.81907 47406 6
0.612	.57450 56093 1	.81850 06443 9
0.613	.57532 38225 6	.81792 57296 3
0.614	.57614 14604 9	.81734 99969 4

*Tables of Sines and Cosines ( $\theta$  in radians)—continued.*

$\theta$	Sin $\theta$	Cos $\theta$
0.615	.57695 85222 8	.81677 34469 0
0.616	.57777 50071 2	.81619 60800 9
0.617	.57859 09141 7	.81561 78970 8
0.618	.57940 62426 4	.81503 88984 5
0.619	.58022 09917 0	.81445 90847 9
0.620	.58103 51605 4	.81387 84566 6
0.621	.58184 87483 4	.81329 70146 6
0.622	.58266 17543 0	.81271 47593 6
0.623	.58347 41775 9	.81213 16913 5
0.624	.58428 60174 1	.81154 78112 0
0.625	.58509 72729 4	.81096 31195 0
0.626	.58590 79433 8	.81037 76168 5
0.627	.58671 80279 0	.80979 13038 1
0.628	.58752 75257 1	.80920 41809 9
0.629	.58833 64360 0	.80861 62489 6
0.630	.58914 47579 4	.80802 75083 1
0.631	.58995 24907 4	.80743 79596 4
0.632	.59075 96335 9	.80684 76035 3
0.633	.59156 61856 8	.80625 64405 7
0.634	.59237 21462 0	.80566 44713 5
0.635	.59317 75143 6	.80507 16964 7
0.636	.59398 22893 3	.80447 81165 2
0.637	.59478 64703 2	.80388 37320 9
0.638	.59559 00565 3	.80328 85437 8
0.639	.59639 30471 4	.80269 25521 8
0.640	.59719 54413 6	.80209 57578 8
0.641	.59799 72383 9	.80149 81614 9
0.642	.59879 84374 2	.80089 97636 1
0.643	.59959 90376 5	.80030 05648 2
0.644	.60039 90382 8	.79970 05657 3
0.645	.60119 84385 1	.79909 97669 4
0.646	.60199 72375 5	.79849 81690 5
0.647	.60279 54345 9	.79789 57726 7
0.648	.60359 30288 3	.79729 25783 9
0.649	.60439 00194 8	.79668 85868 1
0.650	.60518 64057 4	.79608 37985 5
0.651	.60598 21868 1	.79547 82142 0
0.652	.60677 73619 0	.79487 18343 8
0.653	.60757 19302 1	.79426 46596 8
0.654	.60836 58909 5	.79365 66907 2
0.655	.60915 92433 3	.79304 79281 0
0.656	.60995 19865 5	.79243 83724 4
0.657	.61074 41198 1	.79182 80243 3
0.658	.61153 56423 3	.79121 68844 0
0.659	.61232 65533 1	.79060 49532 5
0.660	.61311 68519 7	.78999 22315 0
0.661	.61390 65375 1	.78937 87197 5
0.662	.61469 56091 5	.78876 44186 3
0.663	.61548 40660 9	.78814 93287 4
0.664	.61627 19075 4	.78753 34507 0
0.665	.61705 91327 3	.78691 67851 3
0.666	.61784 57408 5	.78629 93326 4
0.667	.61863 17311 3	.78568 10938 5
0.668	.61941 71027 8	.78506 20693 8
0.669	.62020 18550 1	.78444 22598 5
0.670	.62098 59870 4	.78382 16658 8
0.671	.62176 94980 8	.78320 02880 9
0.672	.62255 23873 5	.78257 81270 9

Tables of Sines and Cosines ( $\theta$  in radians)—continued.

$\theta$	Sin $\theta$	Cos $\theta$
0.673	•62333 46540 7	•78195 51835 2
0.674	•62411 62974 6	•78133 14579 9
0.675	•62489 73167 3	•78070 69511 3
0.676	•62567 77111 0	•78008 16635 7
0.677	•62645 74797 9	•77945 55959 2
0.678	•62723 66220 3	•77882 87488 2
0.679	•62801 51370 3	•77820 11228 8
0.680	•62879 30240 2	•77757 27187 5
0.681	•62957 02822 1	•77694 35370 5
0.682	•63034 69108 3	•77631 35784 0
0.683	•63112 29091 1	•77568 28434 3
0.684	•63189 82762 6	•77505 13327 9
0.685	•63267 30115 2	•77441 90470 9
0.686	•63344 71141 0	•77378 59869 8
0.687	•63422 05832 3	•77315 21530 7
0.688	•63499 34181 5	•77251 75460 2
0.689	•63576 56180 7	•77188 21664 5
0.690	•63653 71822 2	•77124 60150 0
0.691	•63730 81098 4	•77060 90923 0
0.692	•63807 84001 5	•76997 13989 9
0.693	•63884 80523 8	•76933 29357 1
0.694	•63961 70657 6	•76869 37031 0
0.695	•64038 54395 3	•76805 37017 9
0.696	•64115 31729 1	•76741 29324 3
0.697	•64192 02651 4	•76677 13956 6
0.698	•64268 67154 5	•76612 90921 2
0.699	•64345 25230 7	•76548 60224 4
0.700	•64421 76872 4	•76484 21872 8
0.701	•64498 22071 9	•76419 75872 8
0.702	•64574 60821 6	•76355 22230 9
0.703	•64650 93113 8	•76290 60953 3
0.704	•64727 18940 9	•76225 92046 8
0.705	•64803 38295 3	•76161 15517 6
0.706	•64879 51169 4	•76096 31372 3
0.707	•64955 57555 6	•76031 39617 4
0.708	•65031 57446 1	•75966 40259 4
0.709	•65107 50833 5	•75901 33304 7
0.710	•65183 37710 2	•75836 18759 9
0.711	•65259 18068 5	•75770 96631 5
0.712	•65334 91900 9	•75705 66925 9
0.713	•65410 59199 9	•75640 29649 8
0.714	•65486 19957 7	•75574 84809 7
0.715	•65561 74167 0	•75509 32412 1
0.716	•65637 21820 0	•75443 72463 6
0.717	•65712 62909 4	•75378 04970 7
0.718	•65787 97427 5	•75312 29939 9
0.719	•65863 25366 7	•75246 47378 0
0.720	•65938 46719 7	•75180 57291 4
0.721	•66013 61478 8	•75114 59686 8
0.722	•66088 69636 6	•75048 54570 7
0.723	•66163 71185 5	•74982 41949 7
0.724	•66238 66118 0	•74916 21830 5
0.725	•66313 54426 6	•74849 94219 7
0.726	•66388 36103 9	•74783 59123 8
0.727	•66463 11142 4	•74717 16549 7
0.728	•66537 79534 5	•74650 66503 8
0.729	•66612 41272 9	•74584 08992 8
0.730	•66686 96350 0	•74517 44023 4

*Tables of Sines and Cosines ( $\theta$  in radians)—continued.*

$\theta$	Sin $\theta$	Cos $\theta$
0.731	•66761 44758 5	•74450 71602 3
0.732	•66835 86490 8	•74383 91736 2
0.733	•66910 21539 5	•74317 04431 6
0.734	•66984 49897 1	•74250 09695 3
0.735	•67058 71556 4	•74183 07534 0
0.736	•67132 86509 7	•74115 97954 4
0.737	•67206 94749 8	•74048 80963 2
0.738	•67280 96269 2	•73981 56567 2
0.739	•67354 91060 5	•73914 24772 9
0.740	•67428 79116 3	•73846 85587 3
0.741	•67502 60429 2	•73779 39017 0
0.742	•67576 34991 9	•73711 85068 7
0.743	•67650 02796 9	•73644 23749 2
0.744	•67723 63836 9	•73576 55065 3
0.745	•67797 18104 5	•73508 79023 8
0.746	•67870 65592 5	•73440 95631 4
0.747	•67944 06293 4	•73373 04894 9
0.748	•68017 40199 8	•73305 06821 1
0.749	•68090 67304 6	•73237 01416 8
0.750	•68163 87600 2	•73168 88688 7
0.751	•68237 01079 5	•73100 68643 8
0.752	•68310 07735 1	•73032 41288 9
0.753	•68383 07559 7	•72964 06630 6
0.754	•68456 00545 9	•72895 64676 0
0.755	•68528 86686 6	•72827 15431 8
0.756	•68601 65974 3	•72758 58904 9
0.757	•68674 38402 0	•72689 95102 2
0.758	•68747 03962 1	•72621 24030 4
0.759	•68819 62647 6	•72552 45696 5
0.760	•68892 14451 1	•72483 60107 4
0.761	•68964 59365 4	•72414 67269 9
0.762	•69036 97383 2	•72345 67191 0
0.763	•69109 28497 4	•72276 59877 5
0.764	•69181 52700 6	•72207 45336 3
0.765	•69253 69985 6	•72138 23574 4
0.766	•69325 80345 3	•72068 94598 6
0.767	•69397 83772 4	•71999 58416 0
0.768	•69469 80259 8	•71930 15033 4
0.769	•69541 69800 1	•71860 64457 8
0.770	•69613 52386 3	•71791 06696 1
0.771	•69685 28011 1	•71721 41755 3
0.772	•69756 96667 4	•71651 69642 4
0.773	•69828 58348 0	•71581 90364 3
0.774	•69900 13045 7	•71512 03928 0
0.775	•69971 60753 5	•71442 10340 6
0.776	•70043 01464 0	•71372 09608 9
0.777	•70114 35170 3	•71302 01740 0
0.778	•70185 61865 1	•71231 86740 9
0.779	•70256 81541 4	•71161 64618 6
0.780	•70327 94192 0	•71091 35380 1
0.781	•70398 99809 8	•71020 99032 5
0.782	•70469 98387 7	•70950 55582 8
0.783	•70540 89918 6	•70880 05038 1
0.784	•70611 74395 4	•70809 47405 4
0.785	•70682 51811 0	•70738 82691 7
0.786	•70753 22158 4	•70668 10904 1
0.787	•70823 85430 5	•70597 32049 7
0.788	•70894 41620 2	•70526 46135 6

Tables of Sines and Cosines ( $\theta$  in radians)—continued.

$\theta$	Sin $\theta$	Cos $\theta$
0.789	.70964 90720 4	.70455 53168 8
0.790	.71035 32724 2	.70384 53156 5
0.791	.71105 67624 4	.70313 46105 8
0.792	.71175 95414 0	.70242 32023 6
0.793	.71246 16086 1	.70171 10917 3
0.794	.71316 29633 5	.70099 82793 8
0.795	.71386 36049 3	.70028 47660 4
0.796	.71456 35326 5	.69957 05524 1
0.797	.71526 27458 1	.69885 56392 1
0.798	.71596 12437 0	.69814 00271 6
0.799	.71665 90256 3	.69742 37169 7
0.800	.71735 60909 0	.69670 67093 5
0.801	.71805 24388 1	.69598 90050 2
0.802	.71874 80686 8	.69527 06047 1
0.803	.71944 29797 9	.69455 15091 2
0.804	.72013 71714 6	.69383 17189 9
0.805	.72083 06430 0	.69311 12350 2
0.806	.72152 33937 0	.69239 00579 4
0.807	.72221 54228 8	.69166 81884 7
0.808	.72290 67298 5	.69094 56273 4
0.809	.72359 73139 1	.69022 23752 6
0.810	.72428 71743 7	.68949 84329 5
0.811	.72497 63105 4	.68877 38011 5
0.812	.72566 47217 4	.68804 84805 7
0.813	.72635 24072 8	.68732 24719 5
0.814	.72703 93664 6	.68659 57760 0
0.815	.72772 55986 0	.68586 83934 6
0.816	.72841 11030 2	.68514 03250 4
0.817	.72909 58790 2	.68441 15714 9
0.818	.72977 99259 3	.68368 21335 3
0.819	.73046 32430 6	.68295 20118 8
0.820	.73114 58297 3	.68222 12072 9
0.821	.73182 76852 5	.68148 97204 7
0.822	.73250 88089 4	.68075 75521 6
0.823	.73318 92001 2	.68002 47031 0
0.824	.73386 88581 2	.67929 11740 0
0.825	.73454 77822 5	.67855 69656 2
0.826	.73522 59718 2	.67782 20786 8
0.827	.73590 34261 8	.67708 65139 2
0.828	.73658 01446 3	.67635 02720 8
0.829	.73725 61265 0	.67561 33538 8
0.830	.73793 13711 1	.67487 57600 7
0.831	.73860 58777 9	.67413 74913 9
0.832	.73927 96458 7	.67339 85485 6
0.833	.73995 26746 6	.67265 89323 4
0.834	.74062 49635 1	.67191 86434 6
0.835	.74129 65117 3	.67117 76826 6
0.836	.74196 73186 5	.67043 60506 8
0.837	.74263 73836 1	.66969 37482 7
0.838	.74330 67059 2	.66895 07761 6
0.839	.74397 52849 3	.66820 71351 1
0.840	.74464 31199 7	.66746 28258 4
0.841	.74531 02103 6	.66671 78491 7
0.842	.74597 65554 5	.66597 22056 7
0.843	.74664 21545 5	.66522 58962 5
0.844	.74730 70070 2	.66447 89216 1
0.845	.74797 11121 7	.66373 12824 9
0.846	.74863 44693 6	.66298 29796 3



*Tables of Sines and Cosines ( $\theta$  in radians)—continued.*

$\theta$	Sin $\theta$	Cos $\theta$
0.847	.74929 70779 1	.66223 40138 0
0.848	.74995 89371 7	.66148 43857 3
0.849	.75062 00464 6	.66073 40961 7
0.850	.75128 04051 4	.65998 31458 8
0.851	.75194 00125 4	.65923 15356 1
0.852	.75259 88679 9	.65847 92661 1
0.853	.75325 69708 5	.65772 63381 3
0.854	.75391 43204 5	.65697 27524 2
0.855	.75457 09161 3	.65621 85097 4
0.856	.75522 67572 5	.65546 36108 4
0.857	.75588 18431 4	.65470 80564 8
0.858	.75653 61731 4	.65395 18474 0
0.859	.75718 97466 1	.65319 49843 8
0.860	.75784 25629 0	.65243 74681 6
0.861	.75849 46213 3	.65167 92995 1
0.862	.75914 59212 8	.65092 04791 7
0.863	.75979 64620 7	.65016 10079 2
0.864	.76044 62430 8	.64940 08865 0
0.865	.76109 52636 3	.64864 01156 9
0.866	.76174 35230 9	.64787 86962 3
0.867	.76239 10208 1	.64711 66288 9
0.868	.76303 77561 3	.64635 39144 4
0.869	.76368 37284 2	.64559 05536 4
0.870	.76432 89370 3	.64482 65472 4
0.871	.76497 33813 0	.64406 18960 2
0.872	.76561 70606 0	.64329 66007 3
0.873	.76625 99742 9	.64253 06621 5
0.874	.76690 21217 1	.64176 40810 4
0.875	.76754 35022 4	.64099 68581 6
0.876	.76818 41152 2	.64022 89942 9
0.877	.76882 39600 1	.63946 04901 9
0.878	.76946 30359 8	.63869 13466 3
0.879	.77010 13424 9	.63792 15643 7
0.880	.77073 88789 0	.63715 11442 0
0.881	.77137 56445 7	.63638 00868 7
0.882	.77201 16388 6	.63560 83931 7
0.883	.77264 68611 4	.63483 60638 5
0.884	.77328 13107 8	.63406 30997 0
0.885	.77391 49871 3	.63328 95014 9
0.886	.77454 78895 7	.63251 52699 9
0.887	.77518 00174 6	.63174 04059 7
0.888	.77581 13701 7	.63096 49102 1
0.889	.77644 19470 7	.63018 87834 9
0.890	.77707 17475 3	.62941 20265 7
0.891	.77770 07709 1	.62863 46402 5
0.892	.77832 90166 0	.62785 66252 9
0.893	.77895 64839 5	.62707 79824 8
0.894	.77958 31723 5	.62629 87125 8
0.895	.78020 90811 7	.62551 88163 9
0.896	.78083 42097 8	.62473 82946 8
0.897	.78145 85575 5	.62395 71482 3
0.898	.78208 21238 7	.62317 53778 3
0.899	.78270 49081 0	.62239 29842 4
0.900	.78332 69096 3	.62160 99682 7
0.901	.78394 81278 3	.62082 63306 9
0.902	.78456 85620 8	.62004 20722 8
0.903	.78518 82117 7	.61925 71938 2
0.904	.78580 70762 6	.61847 16961 1

Tables of Sines and Cosines ( $\theta$  in radians)—continued.

$\theta$	Sin $\theta$			Cos $\theta$		
0.905	.78642	51549	5	.61768	55799	3
0.906	.78704	24472	2	.61689	88460	7
0.907	.78765	89524	4	.61611	14953	0
0.908	.78827	46700	0	.61532	35284	2
0.909	.78888	95992	9	.61453	49462	2
0.910	.78950	37396	9	.61374	57494	9
0.911	.79011	70905	9	.61295	59390	1
0.912	.79072	96513	6	.61216	55155	7
0.913	.79134	14214	1	.61137	44799	7
0.914	.79195	24001	2	.61058	28329	5
0.915	.79256	25868	7	.60979	05754	3
0.916	.79317	19810	7	.60899	77080	8
0.917	.79378	05820	9	.60820	42317	3
0.918	.79438	83893	3	.60741	01471	8
0.919	.79499	54021	8	.60661	54552	2
0.920	.79560	16200	4	.60582	01566	4
0.921	.79620	70422	9	.60502	42522	5
0.922	.79681	16683	4	.60422	77428	2
0.923	.79741	54975	8	.60343	06291	7
0.924	.79801	85294	0	.60263	29120	9
0.925	.79862	07632	0	.60183	45923	8
0.926	.79922	21983	8	.60103	56708	3
0.927	.79982	28343	4	.60023	61482	5
0.928	.80042	26704	8	.59943	60254	3
0.929	.80102	17061	9	.59863	53031	8
0.930	.80161	99408	8	.59783	39822	9
0.931	.80221	73739	6	.59703	20635	6
0.932	.80281	40048	1	.59622	95478	1
0.933	.80340	98328	5	.59542	64358	2
0.934	.80400	48574	8	.59462	27284	1
0.935	.80459	90781	1	.59381	84263	7
0.936	.80519	24941	4	.59301	35305	2
0.937	.80578	51049	8	.59220	80416	5
0.938	.80637	69100	3	.59140	19605	8
0.939	.80696	79087	0	.59059	52881	0
0.940	.80755	81004	1	.58978	80250	3
0.941	.80814	74845	5	.58898	01721	7
0.942	.80873	60605	5	.58817	17303	3
0.943	.80932	38278	2	.58736	27003	2
0.944	.80991	07857	6	.58655	30829	4
0.945	.81049	69337	9	.58574	28790	2
0.946	.81108	22713	2	.58493	20893	5
0.947	.81166	67977	7	.58412	07147	5
0.948	.81225	05125	6	.58330	87560	2
0.949	.81283	34150	9	.58249	62139	9
0.950	.81341	55047	9	.58168	30894	6
0.951	.81399	67810	7	.58086	93832	5
0.952	.81457	72433	6	.58005	50961	7
0.953	.81515	68910	7	.57924	02290	4
0.954	.81573	57236	3	.57842	47826	6
0.955	.81631	37404	5	.57760	87578	6
0.956	.81689	09409	5	.57679	21554	5
0.957	.81746	73245	6	.57597	49762	5
0.958	.81804	28907	1	.57515	72210	8
0.959	.81861	76388	1	.57433	88907	4
0.960	.81919	15683	0	.57351	99860	7
0.961	.81976	46786	0	.57270	05078	8
0.962	.82033	69691	3	.57188	04569	9

*Tables of Sines and Cosines ( $\theta$  in radians)—continued.*

$\theta$	Sin $\theta$			Cos $\theta$		
0.963	•82090	84393	2	•57105	98342	2
0.964	•82147	90886	0	•57023	86403	8
0.965	•82204	89164	1	•56941	68763	1
0.966	•82261	79221	7	•56859	45428	2
0.967	•82318	61053	1	•56777	16407	4
0.968	•82375	34652	6	•56694	81708	9
0.969	•82432	00014	6	•56612	41340	9
0.970	•82488	57133	4	•56529	95311	6
0.971	•82545	06003	3	•56447	43629	3
0.972	•82601	46618	8	•56364	86302	3
0.973	•82657	78974	0	•56282	23338	9
0.974	•82714	03063	6	•56199	54747	2
0.975	•82770	18881	7	•56116	80535	5
0.976	•82826	26422	8	•56034	00712	1
0.977	•82882	25681	2	•55951	15285	4
0.978	•82938	16651	5	•55868	24263	5
0.979	•82993	99327	9	•55785	27654	9
0.980	•83049	73704	9	•55702	25467	7
0.981	•83105	39777	0	•55619	17710	2
0.982	•83160	97538	5	•55536	04390	9
0.983	•83216	46983	9	•55452	85517	9
0.984	•83271	88107	7	•55369	61099	7
0.985	•83327	20904	2	•55286	31144	5
0.986	•83382	45368	1	•55202	95660	7
0.987	•83437	61493	7	•55119	54656	5
0.988	•83492	69275	6	•55036	08140	4
0.989	•83547	68708	2	•54952	56120	8
0.990	•83602	59786	0	•54868	98605	8
0.991	•83657	42503	6	•54785	35604	0
0.992	•83712	16855	4	•54701	67123	6
0.993	•83766	82836	0	•54617	93173	0
0.994	•83821	40439	9	•54534	13760	7
0.995	•83875	89661	7	•54450	28895	0
0.996	•83930	30495	9	•54366	38584	2
0.997	•83984	62937	0	•54282	42836	8
0.998	•84038	86979	8	•54198	41661	1
0.999	•84093	02618	6	•54114	35065	6
1.000	•84147	09848	1	•54030	23058	7
1.001	•84201	08662	9	•53946	05648	7
1.002	•84254	99057	6	•53861	82844	2
1.003	•84308	81026	8	•53777	54653	4
1.004	•84362	54565	1	•53693	21084	9
1.005	•84416	19667	1	•53608	82147	1
1.006	•84469	76327	6	•53524	37848	4
1.007	•84523	24541	1	•53439	88197	3
1.008	•84576	64302	2	•53355	33202	1
1.009	•84629	95605	7	•53270	72871	5
1.010	•84683	18446	2	•53186	07213	7
1.011	•84736	32818	3	•53101	36237	4
1.012	•84789	38716	9	•53016	59950	9
1.013	•84842	36136	5	•52931	78362	8
1.014	•84895	25071	8	•52846	91481	5
1.015	•84948	05517	7	•52761	99315	5
1.016	•85000	77468	7	•52677	01873	3
1.017	•85053	40919	7	•52591	99163	4
1.018	•85105	95865	3	•52506	91194	3
1.019	•85158	42300	3	•52421	77974	5
1.020	•85210	80219	5	•52336	59512	5

Tables of Sines and Cosines ( $\theta$  in radians)—continued.

$\theta$	Sin $\theta$	Cos $\theta$
1.021	·85263 09617 6	·52251 35816 9
1.022	·85315 30489 4	·52166 06896 1
1.023	·85367 42829 6	·52080 72758 8
1.024	·85419 46633 2	·51995 33413 3
1.025	·85471 41894 7	·51909 88868 3
1.026	·85523 28609 2	·51824 39132 4
1.027	·85575 06771 3	·51738 84214 0
1.028	·85626 76375 9	·51653 24121 7
1.029	·85678 37417 8	·51567 58864 1
1.030	·85729 89891 9	·51481 88449 7
1.031	·85781 33793 0	·51396 12887 1
1.032	·85832 69115 9	·51310 32185 0
1.033	·85883 95855 6	·51224 46351 8
1.034	·85935 14006 9	·51138 55396 1
1.035	·85986 23564 7	·51052 59326 6
1.036	·86037 24523 9	·50966 58151 9
1.037	·86088 16879 3	·50880 51880 4
1.038	·86139 00626 0	·50794 40521 0
1.039	·86189 75758 7	·50708 24082 1
1.040	·86240 42272 4	·50622 02572 3
1.041	·86291 00162 1	·50535 76000 4
1.042	·86341 49422 7	·50449 44374 9
1.043	·86391 90049 2	·50363 07704 4
1.044	·86442 22036 5	·50276 65997 7
1.045	·86492 45379 5	·50190 19263 2
1.046	·86542 60073 3	·50103 67509 8
1.047	·86592 66112 9	·50017 10746 0
1.048	·86642 63493 2	·49930 48980 4
1.049	·86692 52209 2	·49843 82221 9
1.050	·86742 32255 9	·49757 10478 9
1.051	·86792 03628 5	·49670 33760 3
1.052	·86841 66321 8	·49583 52074 6
1.053	·86891 20331 0	·49496 65430 5
1.054	·86940 65651 0	·49409 73836 8
1.055	·86990 02277 0	·49322 77302 1
1.056	·87039 30204 0	·49235 75835 1
1.057	·87088 49427 0	·49148 69444 6
1.058	·87137 59941 2	·49061 58139 2
1.059	·87186 61741 7	·48974 41927 6
1.060	·87235 54823 4	·48887 20818 6
1.061	·87284 39181 7	·48799 94820 9
1.062	·87333 14811 5	·48712 63943 1
1.063	·87381 81707 9	·48625 28194 2
1.064	·87430 39866 2	·48537 87582 6
1.065	·87478 89281 5	·48450 42117 3
1.066	·87527 29948 8	·48362 91807 0
1.067	·87575 61863 5	·48275 36660 4
1.068	·87623 85020 6	·48187 76686 2
1.069	·87671 99415 3	·48100 11893 2
1.070	·87720 05042 7	·48012 42290 3
1.071	·87768 01898 2	·47924 67886 1
1.072	·87815 89976 9	·47836 88689 4
1.073	·87863 69274 0	·47749 04709 1
1.074	·87911 39784 7	·47661 15953 8
1.075	·87959 01504 3	·47573 22432 4
1.076	·88006 54428 0	·47485 24153 7
1.077	·88053 98551 1	·47397 21126 5
1.078	·88101 33868 7	·47309 13359 5

*Tables of Sines and Cosines ( $\theta$  in radians)—continued.*

$\theta$	Sin $\theta$	Cos $\theta$
1·079	·88148 60376 2	·47221 00861 7
1·080	·88195 78068 8	·47132 83641 7
1·081	·88242 86941 9	·47044 61708 5
1·082	·88289 86990 7	·46956 35070 8
1·083	·88336 78210 5	·46868 03737 5
1·084	·88383 60596 6	·46779 67717 3
1·085	·88430 34144 4	·46691 27019 2
1·086	·88476 98849 1	·46602 81652 0
1·087	·88523 54706 1	·46514 31624 5
1·088	·88570 01710 8	·46425 76945 5
1·089	·88616 39858 5	·46337 17624 0
1·090	·88662 69144 5	·46248 53668 8
1·091	·88708 89564 3	·46159 85088 7
1·092	·88755 01113 1	·46071 11892 6
1·093	·88801 03786 5	·45982 34089 4
1·094	·88846 97579 8	·45893 51688 0
1·095	·88892 82488 3	·45804 64697 2
1·096	·88938 58507 6	·45715 73126 0
1·097	·88984 25633 1	·45626 76983 1
1·098	·89029 83860 1	·45537 76277 7
1·099	·89075 33184 1	·45448 71018 4
1·100	·89120 73600 6	·45359 61214 3
1·101	·89166 05105 0	·45270 46874 2
1·102	·89211 27692 9	·45181 28007 0
1·103	·89256 41359 5	·45092 04621 7
1·104	·89301 46100 6	·45002 76727 3
1·105	·89346 41911 5	·44913 44332 5
1·106	·89391 28787 8	·44824 07446 4
1·107	·89436 06724 9	·44734 66077 9
1·108	·89480 75718 4	·44645 20236 0
1·109	·89525 35763 9	·44555 69929 5
1·110	·89569 86856 8	·44466 15167 4
1·111	·89614 28992 7	·44376 55958 7
1·112	·89658 62167 2	·44286 92312 4
1·113	·89702 86375 9	·44197 24237 4
1·114	·89747 01614 2	·44107 51742 7
1·115	·89791 07877 9	·44017 74837 2
1·116	·89835 05162 4	·43927 93529 9
1·117	·89878 93463 5	·43838 07829 8
1·118	·89922 72776 6	·43748 17746 0
1·119	·89966 43097 5	·43658 23287 3
1·120	·90010 04421 8	·43568 24462 8
1·121	·90053 56745 0	·43478 21281 4
1·122	·90097 00062 9	·43388 13752 3
1·123	·90140 34371 1	·43298 01884 3
1·124	·90183 59665 2	·43207 85686 5
1·125	·90226 75941 0	·43117 65168 0
1·126	·90269 83194 1	·43027 40337 7
1·127	·90312 81420 2	·42937 11204 6
1·128	·90355 70615 1	·42846 77777 8
1·129	·90398 50774 4	·42756 40066 4
1·130	·90441 21893 8	·42665 98079 3
1·131	·90483 83969 1	·42575 51825 6
1·132	·90526 36996 0	·42485 01314 4
1·133	·90568 80970 3	·42394 46554 6
1·134	·90611 15887 7	·42303 87555 5
1·135	·90653 41744 0	·42213 24325 9
1·136	·90695 58535 0	·42122 56875 0

Tables of Sines and Cosines ( $\theta$  in radians)—continued.

$\theta$	Sin $\theta$			Cos $\theta$		
1.137	.90737	66256	4	.42031	85211	8
1.138	.90779	64904	0	.41941	09345	5
1.139	.90821	54473	6	.41850	29285	1
1.140	.90863	34961	2	.41759	45039	6
1.141	.90905	06362	3	.41668	56618	2
1.142	.90946	68673	0	.41577	64029	9
1.143	.90988	21889	0	.41486	67283	8
1.144	.91029	66006	2	.41395	66389	1
1.145	.91071	01020	4	.41304	61354	9
1.146	.91112	26927	5	.41213	52190	1
1.147	.91153	43723	4	.41122	38904	1
1.148	.91194	51404	0	.41031	21505	7
1.149	.91235	49965	1	.40940	00004	3
1.150	.91276	39402	6	.40848	74408	8
1.151	.91317	19712	5	.40757	44728	5
1.152	.91357	90890	7	.40666	10972	5
1.153	.91398	52933	1	.40574	73149	8
1.154	.91439	05835	6	.40483	31269	6
1.155	.91479	49594	3	.40391	85341	2
1.156	.91519	84205	0	.40300	35373	5
1.157	.91560	09663	7	.40208	81375	8
1.158	.91600	25966	4	.40117	23357	2
1.159	.91640	33109	1	.40025	61326	9
1.160	.91680	31087	7	.39933	95294	1
1.161	.91720	19898	3	.39842	25267	8
1.162	.91759	99536	9	.39750	51257	3
1.163	.91799	69999	5	.39658	73271	8
1.164	.91839	31282	1	.39566	91320	4
1.165	.91878	83380	8	.39475	05412	3
1.166	.91918	26291	6	.39383	15556	7
1.167	.91957	60010	6	.39291	21762	8
1.168	.91996	84533	9	.39199	24039	7
1.169	.92035	99857	4	.39107	22396	8
1.170	.92075	05977	4	.39015	16843	1
1.171	.92114	02889	8	.38923	07387	9
1.172	.92152	90590	8	.38830	94040	4
1.173	.92191	69076	6	.38738	76809	8
1.174	.92230	38343	2	.38646	55705	3
1.175	.92268	98386	7	.38554	30736	2
1.176	.92307	49203	3	.38462	01911	6
1.177	.92345	90789	2	.38369	69240	8
1.178	.92384	23140	6	.38277	32733	1
1.179	.92422	46253	4	.38184	92397	6
1.180	.92460	60124	1	.38092	48243	7
1.181	.92498	64748	7	.38000	00280	5
1.182	.92536	60123	4	.37907	48517	3
1.183	.92574	46244	4	.37814	92963	3
1.184	.92612	23108	0	.37722	33627	8
1.185	.92649	90710	4	.37629	70520	2
1.186	.92687	49047	8	.37537	03649	5
1.187	.92724	98116	5	.37444	33025	2
1.188	.92762	37912	6	.37351	58656	4
1.189	.92799	68432	5	.37258	80552	4
1.190	.92836	89672	5	.37165	98722	6
1.191	.92874	01628	7	.37073	13176	2
1.192	.92911	04297	6	.36980	23922	4
1.193	.92947	97675	4	.36887	30970	7
1.194	.92984	81758	3	.36794	34330	2

Tables of Sines and Cosines ( $\theta$  in radians)—continued.

$\theta$	Sin $\theta$			Cos $\theta$		
1.195	.93021	56542	8	.36701	34010	3
1.196	.93058	22025	1	.36608	30020	2
1.197	.93094	78201	6	.36515	22369	3
1.198	.93131	25068	6	.36422	11066	9
1.199	.93167	62622	5	.36328	96122	3
1.200	.93203	90859	7	.36235	77544	8
1.201	.93240	09776	4	.36142	55343	7
1.202	.93276	19369	2	.36049	29528	3
1.203	.93312	19634	3	.35956	00108	0
1.204	.93348	10568	2	.35862	67092	2
1.205	.93383	92167	3	.35769	30490	0
1.206	.93419	64428	0	.35675	90310	9
1.207	.93455	27346	7	.35582	46564	3
1.208	.93490	80919	9	.35488	99259	4
1.209	.93526	25144	0	.35395	48405	6
1.210	.93561	60015	5	.35301	94012	2
1.211	.93596	85530	9	.35208	36088	6
1.212	.93632	01686	5	.35114	74644	3
1.213	.93667	08479	0	.35021	09688	4
1.214	.93702	05904	7	.34927	41230	4
1.215	.93736	93960	3	.34833	69279	7
1.216	.93771	72642	1	.34739	93845	6
1.217	.93806	41946	8	.34646	14937	5
1.218	.93841	01870	9	.34552	32564	9
1.219	.93875	52410	8	.34458	46736	9
1.220	.93909	93563	2	.34364	57463	2
1.221	.93944	25324	6	.34270	64752	9
1.222	.93978	47691	5	.34176	68615	6
1.223	.94012	60660	7	.34082	69060	7
1.224	.94046	64228	5	.33988	66097	5
1.225	.94080	58391	7	.33894	59735	4
1.226	.94114	43146	9	.33800	49983	8
1.227	.94148	18490	6	.33706	36852	2
1.228	.94181	84419	5	.33612	20350	0
1.229	.94215	40930	2	.33518	00486	5
1.230	.94248	88019	3	.33423	77271	2
1.231	.94282	25683	6	.33329	50713	6
1.232	.94315	53919	6	.33235	20823	0
1.233	.94348	72724	1	.33140	87608	9
1.234	.94381	82093	7	.33046	51080	7
1.235	.94414	82025	2	.32952	11247	9
1.236	.94447	72515	1	.32857	68119	8
1.237	.94480	53560	3	.32763	21706	0
1.238	.94513	25157	5	.32668	72015	8
1.239	.94545	87303	3	.32574	19058	8
1.240	.94578	39994	5	.32479	62844	4
1.241	.94610	83227	9	.32385	03382	0
1.242	.94643	17000	2	.32290	40681	1
1.243	.94675	41308	2	.32195	74751	1
1.244	.94707	56148	6	.32101	05601	6
1.245	.94739	61518	3	.32006	33242	0
1.246	.94771	57414	0	.31911	57681	7
1.247	.94803	43832	6	.31816	78930	3
1.248	.94835	20770	8	.31721	96997	2
1.249	.94866	88225	5	.31627	11892	0
1.250	.94898	46193	6	.31532	23624	0
1.251	.94929	94671	7	.31437	32202	7
1.252	.94961	33656	9	.31342	37637	8

Tables of Sines and Cosines ( $\theta$  in radians)—continued.

$\theta$	Sin $\theta$			Cos $\theta$		
1.253	.94992	63146	0	.31247	39938	6
1.254	.95023	83135	7	.31152	39114	6
1.255	.95054	93623	1	.31057	35175	5
1.256	.95085	94605	1	.30962	28130	6
1.257	.95116	86078	4	.30867	17989	4
1.258	.95147	68040	0	.30772	04761	6
1.259	.95178	40486	9	.30676	88456	5
1.260	.95209	03415	9	.30581	69083	8
1.261	.95239	56824	0	.30486	46652	9
1.262	.95270	00708	2	.30391	21173	3
1.263	.95300	35065	4	.30295	92654	6
1.264	.95330	59892	5	.30200	61106	4
1.265	.95360	75186	6	.30105	26538	0
1.266	.95390	80944	6	.30009	88959	2
1.267	.95420	77163	5	.29914	48379	3
1.268	.95450	63840	3	.29819	04808	0
1.269	.95480	40972	1	.29723	58254	8
1.270	.95510	08555	8	.29628	08729	3
1.271	.95539	66588	6	.29532	56240	9
1.272	.95569	15067	3	.29437	00799	3
1.273	.95598	53989	2	.29341	42413	9
1.274	.95627	83351	2	.29245	81094	5
1.275	.95657	03150	4	.29150	16850	4
1.276	.95686	13383	9	.29054	49691	4
1.277	.95715	14048	8	.28958	79626	8
1.278	.95744	05142	2	.28863	06666	5
1.279	.95772	86661	2	.28767	30819	8
1.280	.95801	58602	9	.28671	52096	3
1.281	.95830	20964	4	.28575	70505	7
1.282	.95858	73742	9	.28479	86057	6
1.283	.95887	16935	6	.28383	98761	4
1.284	.95915	50539	5	.28288	08626	9
1.285	.95943	74551	9	.28192	15663	6
1.286	.95971	88969	9	.28096	19881	0
1.287	.95999	93790	7	.28000	21288	8
1.288	.96027	89011	6	.27904	19896	6
1.289	.96055	74629	6	.27808	15714	0
1.290	.96083	50642	1	.27712	08750	6
1.291	.96111	17046	2	.27615	99015	9
1.292	.96138	73839	2	.27519	86519	7
1.293	.96166	21018	3	.27423	71271	4
1.294	.96193	58580	8	.27327	53280	8
1.295	.96220	86523	9	.27231	32557	5
1.296	.96248	04845	0	.27135	09111	0
1.297	.96275	13541	3	.27038	82951	0
1.298	.96302	12610	0	.26942	54087	1
1.299	.96329	02048	5	.26846	22529	0
1.300	.96355	81854	2	.26749	88286	2
1.301	.96382	52024	2	.26653	51368	5
1.302	.96409	12556	0	.26557	11785	4
1.303	.96435	63446	9	.26460	69546	6
1.304	.96462	04694	2	.26364	24661	7
1.305	.96488	36295	3	.26267	77140	4
1.306	.96514	58247	6	.26171	26992	4
1.307	.96540	70548	5	.26074	74227	2
1.308	.96566	73195	2	.25978	18854	5
1.309	.96592	66185	3	.25881	60884	0
1.310	.96618	49516	1	.25785	00325	3



Tables of Sines and Cosines ( $\theta$  in radians)—continued.

$\theta$	Sin $\theta$	Cos $\theta$
1.311	.96644 23185 1	.25688 37188 2
1.312	.96669 87189 6	.25591 71482 2
1.313	.96695 41527 2	.25495 03217 0
1.314	.96720 86195 2	.25398 32402 3
1.315	.96746 21191 2	.25301 59047 8
1.316	.96771 46512 5	.25204 83163 2
1.317	.96796 62156 6	.25108 04758 0
1.318	.96821 68121 2	.25011 23842 1
1.319	.96846 64403 5	.24914 40425 0
1.320	.96871 51001 2	.24817 54516 5
1.321	.96896 27911 7	.24720 66126 3
1.322	.96920 95132 6	.24623 75263 9
1.323	.96945 52661 4	.24526 81939 2
1.324	.96970 00495 7	.24429 86161 8
1.325	.96994 38632 9	.24332 87941 5
1.326	.97018 67070 7	.24235 87287 8
1.327	.97042 85806 7	.24138 84210 6
1.328	.97066 94838 4	.24041 78719 4
1.329	.97090 94163 3	.23944 70824 1
1.330	.97114 83779 2	.23847 60534 3
1.331	.97138 63683 6	.23750 47859 8
1.332	.97162 33874 1	.23653 32810 2
1.333	.97185 94348 4	.23556 15395 3
1.334	.97209 45104 1	.23458 95624 8
1.335	.97232 86138 9	.23361 73508 3
1.336	.97256 17450 4	.23264 49055 7
1.337	.97279 39036 2	.23167 22276 7
1.338	.97302 50894 2	.23069 93180 9
1.339	.97325 53021 8	.22972 61778 1
1.340	.97348 45416 9	.22875 28078 1
1.341	.97371 28077 2	.22777 92090 5
1.342	.97394 01000 4	.22680 53825 2
1.343	.97416 64184 1	.22583 13291 8
1.344	.97439 17626 2	.22485 70500 1
1.345	.97461 61324 4	.22388 25459 8
1.346	.97483 95276 4	.22290 78180 7
1.347	.97506 19480 0	.22193 28672 5
1.348	.97528 33933 0	.22095 76944 9
1.349	.97550 38633 1	.21998 23007 8
1.350	.97572 33578 3	.21900 66870 9
1.351	.97594 18766 2	.21803 08543 9
1.352	.97615 94194 6	.21705 48036 7
1.353	.97637 59861 5	.21607 85358 8
1.354	.97659 15764 6	.21510 20520 2
1.355	.97680 61901 8	.21412 53530 5
1.356	.97701 98271 0	.21314 84399 6
1.357	.97723 24869 9	.21217 13137 2
1.358	.97744 41696 5	.21119 39753 2
1.359	.97765 48748 7	.21021 64257 1
1.360	.97786 46024 4	.20923 86658 9
1.361	.97807 33521 3	.20826 06968 3
1.362	.97828 11237 6	.20728 25195 1
1.363	.97848 79171 0	.20630 41349 1
1.364	.97869 37319 6	.20532 55440 1
1.365	.97889 85681 2	.20434 67477 7
1.366	.97910 24253 9	.20336 77472 0
1.367	.97930 53035 5	.20238 85432 5
1.368	.97950 72024 1	.20140 91369 1

*Tables of Sines and Cosines ( $\theta$  in radians)—continued.*

$\theta$	Sin $\theta$	Cos $\theta$
1·369	·97970 81217 6	·20042 95291 7
1·370	·97990 80614 0	·19944 97210 0
1·371	·98010 70211 3	·19846 97133 7
1·372	·98030 50007 6	·19748 95072 8
1·373	·98050 20000 8	·19650 91037 0
1·374	·98069 80189 0	·19552 85036 1
1·375	·98089 30570 2	·19454 77079 9
1·376	·98108 71142 5	·19356 67178 2
1·377	·98128 01903 9	·19258 55340 9
1·378	·98147 22852 6	·19160 41577 7
1·379	·98166 33986 5	·19062 25898 4
1·380	·98185 35303 7	·18964 08313 0
1·381	·98204 26802 5	·18865 88831 1
1·382	·98223 08480 8	·18767 67462 6
1·383	·98241 80336 7	·18669 44217 4
1·384	·98260 42368 6	·18571 19105 2
1·385	·98278 94574 3	·18472 92136 0
1·386	·98297 36952 2	·18374 63319 4
1·387	·98315 69500 4	·18276 32665 3
1·388	·98333 92216 9	·18178 00183 6
1·389	·98352 05100 1	·18079 65884 2
1·390	·98370 08148 1	·17981 29776 7
1·391	·98388 01359 1	·17882 91871 2
1·392	·98405 84731 3	·17784 52177 3
1·393	·98423 58262 8	·17686 10705 0
1·394	·98441 21952 1	·17587 67464 0
1·395	·98458 75797 2	·17489 22464 3
1·396	·98476 19796 4	·17390 75715 7
1·397	·98493 53948 0	·17292 27228 0
1·398	·98510 78250 3	·17193 77011 1
1·399	·98527 92701 5	·17095 25074 8
1·400	·98544 97299 9	·16996 71429 0
1·401	·98561 92043 8	·16898 16083 5
1·402	·98578 76931 5	·16799 59048 2
1·403	·98595 51961 3	·16701 00332 9
1·404	·98612 17131 6	·16602 39947 6
1·405	·98628 72440 6	·16503 77902 0
1·406	·98645 17886 8	·16405 14206 0
1·407	·98661 53468 5	·16306 48869 5
1·408	·98677 79184 0	·16207 81902 3
1·409	·98693 95031 8	·16109 13314 4
1·410	·98710 01010 1	·16010 43115 5
1·411	·98725 97117 5	·15911 71315 7
1·412	·98741 83352 2	·15812 97924 6
1·413	·98757 59712 8	·15714 22952 2
1·414	·98773 26197 6	·15615 46408 5
1·415	·98788 82805 1	·15516 68303 1
1·416	·98804 29533 7	·15417 88646 2
1·417	·98819 66381 9	·15319 07447 4
1·418	·98834 93348 1	·15220 24716 7
1·419	·98850 10430 8	·15121 40464 0
1·420	·98865 17628 5	·15022 54699 1
1·421	·98880 14939 7	·14923 67432 0
1·422	·98895 02362 9	·14824 78672 5
1·423	·98909 79896 6	·14725 88430 6
1·424	·98924 47539 2	·14626 96716 0
1·425	·98939 05289 5	·14528 03538 8
1·426	·98953 53145 8	·14429 08908 8

Tables of Sines and Cosines ( $\theta$  in radians)—continued.

$\theta$	Sin $\theta$	Cos $\theta$
1.427	.98967 91106 8	.14330 12835 8
1.428	.98982 19171 0	.14231 15329 8
1.429	.98996 37337 0	.14132 16400 8
1.430	.99010 45603 4	.14033 16058 5
1.431	.99024 43968 7	.13934 14312 9
1.432	.99038 32431 5	.13835 11173 8
1.433	.99052 10990 6	.13736 06651 3
1.434	.99065 79644 4	.13637 00755 2
1.435	.99079 38391 6	.13537 93495 3
1.436	.99092 87230 9	.13438 84881 7
1.437	.99106 26160 9	.13339 74924 1
1.438	.99119 55180 3	.13240 63632 7
1.439	.99132 74287 7	.13141 51017 1
1.440	.99145 83481 9	.13042 37087 4
1.441	.99158 82761 5	.12943 21853 4
1.442	.99171 72125 2	.12844 05325 2
1.443	.99184 51571 7	.12744 87512 5
1.444	.99197 21099 8	.12645 68425 3
1.445	.99209 80708 1	.12546 48073 6
1.446	.99222 30395 5	.12447 26467 2
1.447	.99234 70160 7	.12348 03616 1
1.448	.99247 00002 3	.12248 79530 2
1.449	.99259 19919 3	.12149 54219 4
1.450	.99271 29910 4	.12050 27693 7
1.451	.99283 29974 3	.11950 99962 9
1.452	.99295 20109 9	.11851 71037 0
1.453	.99307 00316 0	.11752 40926 0
1.454	.99318 70591 4	.11653 09639 7
1.455	.99330 30934 9	.11553 77188 1
1.456	.99341 81345 3	.11454 43581 2
1.457	.99353 21821 6	.11355 08828 7
1.458	.99364 52362 6	.11255 72940 8
1.459	.99375 72967 2	.11156 35927 3
1.460	.99386 83634 1	.11056 97798 2
1.461	.99397 84362 4	.10957 58563 4
1.462	.99408 75150 9	.10858 18232 8
1.463	.99419 55998 5	.10758 76816 4
1.464	.99430 26904 1	.10659 34324 1
1.465	.99440 87866 8	.10559 90765 9
1.466	.99451 38885 3	.10460 46151 7
1.467	.99461 79958 7	.10361 00491 4
1.468	.99472 11086 0	.10261 53795 1
1.469	.99482 32266 0	.10162 06072 6
1.470	.99492 43497 8	.10062 57333 9
1.471	.99502 44780 3	.09963 07588 9
1.472	.99512 36112 6	.09863 56847 6
1.473	.99522 17493 7	.09764 05120 0
1.474	.99531 88922 5	.09664 52415 9
1.475	.99541 50398 2	.09564 98745 5
1.476	.99551 01919 7	.09465 44118 5
1.477	.99560 43486 1	.09365 88544 9
1.478	.99569 75096 5	.09266 32034 8
1.479	.99578 96749 9	.09166 74598 1
1.480	.99588 08445 4	.09067 16244 6
1.481	.99597 10182 1	.08967 56984 5
1.482	.99606 01959 0	.08867 96827 6
1.483	.99614 83775 4	.08768 35783 9
1.484	.99623 55630 3	.08668 73863 4

Tables of Sines and Cosines ( $\theta$  in radians)—continued.

$\theta$	Sin $\theta$	Cos $\theta$
1.485	.99632 17522 9	.08569 11076 0
1.486	.99640 69452 2	.08469 47431 6
1.487	.99649 11417 4	.08369 82940 4
1.488	.99657 43417 8	.08270 17612 1
1.489	.99665 65452 4	.08170 51456 9
1.490	.99673 77520 4	.08070 84484 5
1.491	.99681 79621 1	.07971 16705 1
1.492	.99689 71753 6	.07871 48128 6
1.493	.99697 53917 1	.07771 78765 0
1.494	.99705 26110 8	.07672 08624 1
1.495	.99712 88334 1	.07572 37716 1
1.496	.99720 40586 0	.07472 66050 8
1.497	.99727 82865 9	.07372 93638 2
1.498	.99735 15173 1	.07273 20488 4
1.499	.99742 37506 7	.07173 46611 2
1.500	.99749 49866 0	.07073 72016 7
1.501	.99756 52250 5	.06973 96714 8
1.502	.99763 44659 2	.06874 20715 5
1.503	.99770 27091 7	.06774 44028 8
1.504	.99776 99547 1	.06674 66664 6
1.505	.99783 62024 8	.06574 88633 0
1.506	.99790 14524 1	.06475 09943 9
1.507	.99796 57044 4	.06375 30607 3
1.508	.99802 89585 1	.06275 50633 2
1.509	.99809 12145 5	.06175 70031 5
1.510	.99815 24725 0	.06075 88812 2
1.511	.99821 27322 9	.05976 06985 3
1.512	.99827 19938 7	.05876 24560 9
1.513	.99833 02571 8	.05776 41548 8
1.514	.99838 75221 6	.05676 57959 1
1.515	.99844 37887 6	.05576 73801 7
1.516	.99849 90569 1	.05476 89086 6
1.517	.99855 33265 6	.05377 03823 9
1.518	.99860 65976 5	.05277 18023 4
1.519	.99865 88701 4	.05177 31695 2
1.520	.99871 01439 8	.05077 44849 3
1.521	.99876 04191 0	.04977 57495 7
1.522	.99880 96954 6	.04877 69644 3
1.523	.99885 79730 1	.04777 81305 1
1.524	.99890 52517 0	.04677 92488 2
1.525	.99895 15314 9	.04578 03203 4
1.526	.99899 68123 3	.04478 13460 9
1.527	.99904 10941 7	.04378 23270 5
1.528	.99908 43769 7	.04278 32642 3
1.529	.99912 66606 8	.04178 41586 3
1.530	.99916 79452 7	.04078 50112 4
1.531	.99920 82306 9	.03978 58230 7
1.532	.99924 75169 0	.03878 65951 1
1.533	.99928 58038 7	.03778 73283 7
1.534	.99932 30915 5	.03678 80238 4
1.535	.99935 93799 0	.03578 86825 2
1.536	.99939 46689 0	.03478 93054 1
1.537	.99942 89585 0	.03378 98935 1
1.538	.99946 22486 8	.03279 04478 3
1.539	.99949 45393 9	.03179 09693 5
1.540	.99952 58306 1	.03079 14590 8
1.541	.99955 61223 0	.02979 19180 2
1.542	.99958 54144 3	.02879 23471 7

*Tables of Sines and Cosines ( $\theta$  in radians)—continued.*

$\theta$	Sin $\theta$	Cos $\theta$
1.543	.99961 37069 8	.02779 27475 3
1.544	.99964 09999 2	.02679 31200 9
1.545	.99966 72932 1	.02579 34658 6
1.546	.99969 25868 4	.02479 37858 4
1.547	.99971 68807 8	.02379 40810 2
1.548	.99974 01749 9	.02279 43524 1
1.549	.99976 24694 7	.02179 46010 0
1.550	.99978 37641 9	.02079 48278 0
1.551	.99980 40591 2	.01979 50338 1
1.552	.99982 33542 5	.01879 52200 2
1.553	.99984 16495 5	.01779 53874 3
1.554	.99985 89450 2	.01679 55370 5
1.555	.99987 52406 2	.01579 56698 8
1.556	.99989 05363 5	.01479 57869 0
1.557	.99990 48321 9	.01379 58891 4
1.558	.99991 81281 3	.01279 59775 7
1.559	.99993 04241 4	.01179 60532 1
1.560	.99994 17202 3	.01079 61170 6
1.561	.99995 20163 7	.00979 61701 1
1.562	.99996 13125 7	.00879 62133 6
1.563	.99996 96088 0	.00779 62478 1
1.564	.99997 69050 6	.00679 62744 7
1.565	.99998 32013 4	.00579 62943 4
1.566	.99998 84976 5	.00479 63084 0
1.567	.99999 27939 6	.00379 63176 8
1.568	.99999 60902 8	.00279 63231 5
1.569	.99999 83866 1	.00179 63258 3
1.570	.99999 96829 3	.00079 63267 1
1.571	.99999 99792 6	-.00020 36732 0
1.572	.99999 92755 9	-.00120 36729 1
1.573	.99999 75719 1	-.00220 36714 2
1.574	.99999 48682 4	-.00320 36677 2
1.575	.99999 11645 8	-.00420 36608 2
1.576	.99998 64609 2	-.00520 36497 2
1.577	.99998 07572 8	-.00620 36334 1
1.578	.99997 40536 6	-.00720 36109 0
1.579	.99996 63500 6	-.00820 35811 9
1.580	.99995 76465 0	-.00920 35432 7
1.581	.99994 79429 8	-.01020 34961 5
1.582	.99993 72395 1	-.01120 34388 2
1.583	.99992 55361 0	-.01220 33702 9
1.584	.99991 28327 7	-.01320 32895 6
1.585	.99989 91295 3	-.01420 31956 3
1.586	.99988 44263 9	-.01520 30874 9
1.587	.99986 87233 6	-.01620 29641 4
1.588	.99985 20204 6	-.01720 28246 0
1.589	.99983 43177 2	-.01820 26678 5
1.590	.99981 56151 3	-.01920 24929 0
1.591	.99979 59127 4	-.02020 22987 5
1.592	.99977 52105 4	-.02120 20843 9
1.593	.99975 35085 7	-.02220 18488 4
1.594	.99973 08068 5	-.02320 15910 8
1.595	.99970 71054 0	-.02420 13101 2
1.596	.99968 24042 4	-.02520 10049 6
1.597	.99965 67034 0	-.02620 06745 9
1.598	.99963 00029 0	-.02720 03180 3
1.599	.99960 23027 7	-.02819 99342 7
1.600	.99957 36030 4	-.02919 95223 0

TABLE II.

*Subsidiary Table of  $\theta - \sin \theta$  and  $1 - \cos \theta$  from  $\theta = .00001$  radian to  $.00100$  radian.*

$\theta$	$\theta - \sin \theta$	$1 - \cos \theta$	1st Difference
.00001	.000 0	.00000 5	.0001 5
02	0 0	0002 0	02 5
03	0 0	0004 5	03 5
04	0 0	0008 0	04 5
05	0 0	0012 5	05 5
06	0 0	0018 0	06 5
07	0 0	0024 5	07 5
08	0 0	0032 0	08 5
09	0 0	0040 5	09 5
10	0 0	0050 0	10 5
11	0 0	0060 5	11 5
12	0 0	0072 0	12 5
13	0 0	0084 5	13 5
14	0 0	0098 0	14 5
15	0 0	0112 5	15 5
16	0 0	0128 0	16 5
17	0 0	0144 5	17 5
18	0 0	0162 0	18 5
19	0 0	0180 5	19 5
20	0 0	0200 0	20 5
21	0 0	0220 5	21 5
22	0 0	0242 0	22 5
23	0 0	0264 5	23 5
24	0 0	0288 0	24 5
25	0 0	0312 5	25 5
26	0 0	0338 0	26 5
27	0 0	0364 5	27 5
28	0 0	0392 0	28 5
29	0 0	0420 5	29 5
30	0 0	0450 0	30 5
31	0 0	0480 5	31 5
32	0 1	0512 0	32 5
33	0 1	0544 5	33 5
34	0 1	0578 0	34 5
35	0 1	0612 5	35 5
36	0 1	0648 0	36 5
37	0 1	0684 5	37 5
38	0 1	0722 0	38 5
39	0 1	0760 5	39 5
40	0 1	0800 0	40 5
41	0 1	0840 5	41 5
42	0 1	0882 0	42 5
43	0 1	0924 5	43 5
44	0 1	0968 0	44 5
45	0 2	1012 5	45 5
46	0 2	1058 0	46 5
47	0 2	1104 5	47 5
48	0 2	1152 0	48 5
49	0 2	1200 5	49 5
50	0 2	1250 0	50 5
51	0 2	1300 5	51 5
52	0 2	1352 0	52 5
53	0 2	1404 5	53 5
54	0 3	1458 0	54 5
55	0 3	1512 5	55 5
56	0 3	1568 0	56 5
57	0 3	1624 5	57 5

*Subsidiary Table of  $\theta - \sin \theta$  and  $1 - \cos \theta$  from  $\theta = \cdot 00001$  radian to  $\cdot 00100$  radian—  
continued.*

$\theta$	$\theta - \sin \theta$	$1 - \cos \theta$	1st Difference
$\cdot 00058$	$\cdot 0^0 3$	$\cdot 0^61682 0$	$\cdot 0^858 5$
59	0 3	1740 5	59 5
60	0 4	1800 0	60 5
61	0 4	1860 5	61 5
62	0 4	1922 0	62 5
63	0 4	1984 5	63 5
64	0 4	2048 0	64 5
65	0 5	2112 5	65 5
66	0 5	2178 0	66 5
67	0 5	2244 5	67 5
68	0 5	2312 0	68 5
69	0 5	2380 5	69 5
70	0 6	2450 0	70 5
71	0 6	2520 5	71 5
72	0 6	2592 0	72 5
73	0 6	2664 5	73 5
74	0 7	2738 0	74 5
75	0 7	2812 5	75 5
76	0 7	2888 0	76 5
77	0 8	2964 5	77 5
78	0 8	3042 0	78 5
79	0 8	3120 5	79 5
80	0 9	3200 0	80 5
81	0 9	3280 5	81 5
82	0 9	3362 0	82 5
83	1 0	3444 5	83 5
84	1 0	3528 0	84 5
85	1 0	3612 5	85 5
86	1 1	3698 0	86 5
87	1 1	3784 5	87 5
88	1 1	3872 0	88 5
89	1 2	3960 5	89 5
90	1 2	4050 0	90 5
91	1 3	4140 5	91 5
92	1 3	4232 0	92 5
93	1 3	4324 5	93 5
94	1 4	4418 0	94 5
95	1 4	4512 5	95 5
96	1 5	4608 0	96 5
97	1 5	4704 5	97 5
98	1 6	4802 0	98 5
99	1 6	4900 5	99 5
100	1 7	5000 0	—

TABLE III.

$\theta$	Sin $\theta$			Cos $\theta$		
·1	+0·09983	34166	46828	+0·99500	41652	78026
·2	+0·19866	93307	95061	+0·98006	65778	41242
·3	+0·29552	02066	61340	+0·95533	64891	25606
·4	+0·38941	83423	08650	+0·92106	09940	02885
·5	+0·47942	55386	04203	+0·87758	25618	90373
·6	+0·56464	24733	95035	+0·82533	56149	09678
·7	+0·64421	76872	37691	+0·76484	21872	84488
·8	+0·71735	60908	99523	+0·69670	67093	47165
·9	+0·78332	69096	27483	+0·62160	99682	70664
1·0	+0·84147	09848	07897	+0·54030	23058	68140
1·1	+0·89120	73600	61435	+0·45359	61214	25577
1·2	+0·93203	90859	67226	+0·36235	77544	76674
1·3	+0·96355	81854	17193	+0·26749	88286	24587
1·4	+0·98544	97299	88460	+0·16996	71429	00241
1·5	+0·99749	49866	04054	+0·07073	72016	67703
1·6	+0·99957	36030	41505	+0·02919	95223	01289
1·7	+0·99166	48104	52469	-0·12884	44942	95525
1·8	+0·97384	76308	78195	-0·22720	20946	93087
1·9	+0·94630	00876	87414	-0·32328	95668	63503
2·0	+0·90929	74268	25682	-0·41614	68365	47142
2·1	+0·86320	93666	48874	-0·50484	61045	99857
2·2	+0·80849	64038	19590	-0·58850	11172	55346
2·3	+0·74570	52121	76720	-0·66627	60212	79824
2·4	+0·67546	31805	51151	-0·73739	37155	41246
2·5	+0·59847	21441	03956	-0·80114	36155	46934
2·6	+0·51550	13718	21464	-0·85688	87533	68947
2·7	+0·42737	98802	33830	-0·90407	21420	17061
2·8	+0·33498	81501	55905	-0·94222	23406	68658
2·9	+0·23924	93292	13982	-0·97095	81651	49591
3·0	+0·14112	00080	59867	-0·98999	24966	00445
3·1	+0·04158	06624	33291	-0·99913	51502	73279
3·2	-0·05837	41434	27580	-0·99829	47757	94753
3·3	-0·15774	56941	43248	-0·98747	97699	08865
3·4	-0·25554	11020	26831	-0·96679	81925	79461
3·5	-0·35078	32276	89620	-0·93645	66872	90796
3·6	-0·44252	04432	94852	-0·89675	84163	34147
3·7	-0·52983	61409	08493	-0·84810	00317	10408
3·8	-0·61185	78909	42719	-0·79096	77119	14417
3·9	-0·68776	61591	83974	-0·72593	23042	00140
4·0	-0·75680	24953	07928	-0·65364	36208	63612
4·1	-0·81827	71110	64411	-0·57482	39465	33269
4·2	-0·87157	57724	13588	-0·49026	08213	40700
4·3	-0·91616	59367	49455	-0·40079	91720	79975
4·4	-0·95160	20738	89516	-0·30733	28699	78420
4·5	-0·97753	01176	65097	-0·21079	57994	30780
4·6	-0·99369	10036	33464	-0·11215	25269	35054
4·7	-0·99992	32575	64101	-0·01238	86634	62891
4·8	-0·99616	46088	35841	+0·08749	89834	39447
4·9	-0·98245	26126	24333	+0·18651	23694	22575
5·0	-0·95892	42746	63138	+0·28366	21854	63226
5·1	-0·92581	46823	27732	+0·37797	77427	12981
5·2	-0·88345	46557	20153	+0·46851	66713	00377
5·3	-0·83226	74422	23901	+0·55437	43361	79161
5·4	-0·77276	44875	55987	+0·63469	28759	42634
5·5	-0·70554	03255	70392	+0·70866	97742	91260



$\theta$	Sin $\theta$			Cos $\theta$		
5.6	-0.63126	66378	72321	+0.77556	58785	10250
5.7	-0.55068	55425	97638	+0.83471	27848	39160
5.8	-0.46460	21794	13757	+0.88551	95169	41319
5.9	-0.37387	66648	30236	+0.92747	84307	44036
6.0	-0.27941	54981	98926	+0.96017	02866	50366
6.1	-0.18216	25042	72096	+0.98326	84384	42585
6.2	-0.08308	94028	17497	+0.99654	20970	23217
6.3	+0.01681	39004	84350	+0.99985	86363	83415
6.4	+0.11654	92048	50493	+0.99318	49187	58193
6.5	+0.21511	99880	87816	+0.97658	76257	28023
6.6	+0.31154	13635	13378	+0.95023	25919	58529
6.7	+0.40484	99206	16598	+0.91438	31482	35319
6.8	+0.49411	33511	38608	+0.86939	74903	49825
6.9	+0.57843	97643	88200	+0.81572	51001	25357
7.0	+0.65698	65987	18789	+0.75390	22543	43305
7.1	+0.72896	90401	25876	+0.68454	66664	42806
7.2	+0.79366	78638	49153	+0.60835	13145	32255
7.3	+0.85043	66206	28564	+0.52607	75173	81105
7.4	+0.89870	80958	11627	+0.43854	73275	74391
7.5	+0.93799	99767	74739	+0.34663	53178	35026
7.6	+0.96791	96720	31486	+0.25125	98425	82255
7.7	+0.98816	82338	77000	+0.15337	38620	37865
7.8	+0.99854	33453	74605	+0.05395	54205	62650
7.9	+0.99894	13418	39772	-0.04600	21256	39537
8.0	+0.98935	82466	23382	-0.14550	00338	08614
8.1	+0.96988	98108	45086	-0.24354	41537	35791
8.2	+0.94073	05566	79773	-0.33915	48609	83835
8.3	+0.90217	18337	56294	-0.43137	68449	70620
8.4	+0.85459	89080	88281	-0.51928	86541	16685
8.5	+0.79848	71126	23490	-0.60201	19026	84824
8.6	+0.73439	70978	74113	-0.67872	00473	20013
8.7	+0.66296	92300	82183	-0.74864	66455	97399
8.8	+0.58491	71928	91762	-0.81109	30140	61656
8.9	+0.50102	08564	57885	-0.86543	52092	41112
9.0	+0.41211	84852	41757	-0.91113	02618	84677
9.1	+0.31909	83623	49353	-0.94772	16021	31112
9.2	+0.22288	99141	00247	-0.97484	36214	04164
9.3	+0.12445	44235	07062	-0.99222	53254	52603
9.4	+0.02477	54254	53358	-0.99969	30420	35206
9.5	-0.07515	11204	61809	-0.99717	21561	96378
9.6	-0.17432	67812	22980	-0.98468	78557	94127
9.7	-0.27176	06264	10943	-0.96236	48798	31310
9.8	-0.36647	91292	51928	-0.93042	62721	04754
9.9	-0.45753	58937	75321	-0.88919	11526	25361
10.0	-0.54402	11108	89370	-0.83907	15290	76452

## PART II.

*Bessel and Neumann Functions of Equal Order and Argument.*

A small number of values of  $J_a(a)$ ,  $J_{a-1}(a)$ , &c., are given in Meissel's Tables<sup>1</sup> of the  $J_a(a)$  functions and the Committee's Tables of the  $G_a(x)$  and  $Y_a(x)$  functions, viz.  $J_a(a)$  from  $a = 1$  to  $a = 24$  and  $G_a(a)$ , &c., from  $a = 1$  to  $a = 13$ . The following tables have been calculated from the formulæ<sup>2</sup> :—

$$J_a(a) = \frac{1}{2\pi\sqrt{3}} \left[ \left(\frac{6}{a}\right)^{\frac{1}{3}} \Gamma\left(\frac{1}{3}\right) - \frac{1}{420} \left(\frac{6}{a}\right)^{\frac{2}{3}} \Gamma\left(\frac{2}{3}\right) - \frac{1}{8100} \left(\frac{6}{a}\right)^{\frac{3}{3}} \Gamma\left(\frac{1}{3}\right) \right. \\ \left. + \frac{1}{182300} \left(\frac{6}{a}\right)^{\frac{4}{3}} \Gamma\left(\frac{2}{3}\right) \dots \right]$$

$$J_{a-1}(a) = \frac{1}{2\pi\sqrt{3}} \left[ \left(\frac{6}{a}\right)^{\frac{1}{3}} \Gamma\left(\frac{1}{3}\right) + \left(\frac{6}{a}\right)^{\frac{2}{3}} \Gamma\left(\frac{2}{3}\right) - \frac{1}{90} \left(\frac{6}{a}\right)^{\frac{4}{3}} \Gamma\left(\frac{1}{3}\right) - \frac{1}{420} \left(\frac{6}{a}\right)^{\frac{5}{3}} \Gamma\left(\frac{2}{3}\right) \right. \\ \left. - \frac{1}{8100} \left(\frac{6}{a}\right)^{\frac{3}{3}} \Gamma\left(\frac{1}{3}\right) + \frac{23}{113400} \left(\frac{6}{a}\right)^{\frac{3}{3}} \Gamma\left(\frac{2}{3}\right) + \frac{947}{74844000} \left(\frac{6}{a}\right)^{\frac{3}{3}} \Gamma\left(\frac{1}{3}\right) \dots \right]$$

For the G functions,

$$G_a(a) = \frac{1}{4} \left[ \left(\frac{6}{a}\right)^{\frac{1}{3}} \Gamma\left(\frac{1}{3}\right) + \frac{1}{420} \left(\frac{6}{a}\right)^{\frac{2}{3}} \Gamma\left(\frac{2}{3}\right) - \frac{1}{8100} \left(\frac{6}{a}\right)^{\frac{3}{3}} \Gamma\left(\frac{1}{3}\right) \right. \\ \left. = \frac{1}{182300} \left(\frac{6}{a}\right)^{\frac{4}{3}} \Gamma\left(\frac{2}{3}\right) \dots \right]$$

$$G_{a-1}(a) = \frac{1}{4} \left[ \left(\frac{6}{a}\right)^{\frac{1}{3}} \Gamma\left(\frac{1}{3}\right) - \left(\frac{6}{a}\right)^{\frac{2}{3}} \Gamma\left(\frac{2}{3}\right) - \frac{1}{90} \left(\frac{6}{a}\right)^{\frac{4}{3}} \Gamma\left(\frac{1}{3}\right) + \frac{1}{420} \left(\frac{6}{a}\right)^{\frac{5}{3}} \Gamma\left(\frac{2}{3}\right) \right. \\ \left. - \frac{1}{8100} \left(\frac{6}{a}\right)^{\frac{3}{3}} \Gamma\left(\frac{1}{3}\right) - \frac{23}{113400} \left(\frac{6}{a}\right)^{\frac{3}{3}} \Gamma\left(\frac{2}{3}\right) + \frac{947}{74844000} \left(\frac{6}{a}\right)^{\frac{3}{3}} \Gamma\left(\frac{1}{3}\right) \dots \right]$$

The Y functions<sup>3</sup> are given by  $Y_a(x) = (\log 2 - \gamma)J_a(x) - G_a(x)$ .

The numerical values occurring in the above formulæ are :—

$$\log \Gamma\left(\frac{1}{3}\right) = 0.42796 \quad 27493 \quad 1426 : \log \Gamma\left(\frac{2}{3}\right) = 0.13165 \quad 64916 \quad 8402. \\ \Gamma\left(\frac{1}{3}\right) = 2.67893 \quad 85347 \quad 077 : \Gamma\left(\frac{2}{3}\right) = 1.35411 \quad 79394 \quad 264.$$

The results were checked by means of the formula

$$J_n(x)Y_{n-1}(x) - J_{n-1}(x)Y_n(x) = \frac{1}{x}.$$

A partial check was also obtained by the use of the Kapteyn Series

$$\sum_{s=1}^{s=\infty} \frac{J_{2s}(2s)}{s^2} = \sum_{s=1}^{s=\infty} \frac{J_{2s-1}(2s-1)}{(2s-1)^2} = \frac{1}{2}.$$

The values of other functions of higher or lower orders are easily calculated from the recurrence formula  $Z_{n-1}(x) - \frac{2n}{x}Z_n(x) + Z_{n+1}(x) = 0$ , where  $Z_n(x)$  stands for  $J_n(x)$ ,  $G_n(x)$  or  $Y_n(x)$ .

<sup>1</sup> and <sup>3</sup> Gray and Mathews, *Bessel Functions*, pp. 266–279, p. 14.

<sup>2</sup> *Phil. Mag.*, June 1916.

TABLE IV.  
Bessel and Neumann Functions of Equal Order and Argument.

$\alpha$	$J_{\alpha}(\alpha)$	$J_{\alpha-1}(\alpha)$	$G_{\alpha}(\alpha)$	$G_{\alpha-1}(\alpha)$	$-Y_{\alpha}(\alpha)$	$-Y_{\alpha-1}(\alpha)$
1	+0.440051	+0.765198	+1.227126	-0.138634	+1.176111	-0.227345
2	-0.352834	-0.576725	-0.969822	+0.168126	-0.928918	+0.101265
3	-0.309063	-0.486091	-0.845939	-0.251957	-0.810109	-0.195604
4	-0.281129	-0.430171	-0.768020	-0.285919	-0.735428	-0.236049
5	-0.261141	-0.391232	-0.712662	-0.301817	-0.682388	-0.256461
6	-0.245837	-0.362087	-0.670456	-0.309544	-0.641956	-0.267567
7	-0.233584	-0.339197	-0.636755	-0.313070	-0.609675	-0.273746
8	-0.223455	-0.320589	-0.608951	-0.314261	-0.583046	-0.277095
9	-0.214881	-0.305067	-0.585445	-0.314077	-0.560534	-0.278710
10	-0.207486	-0.291856	-0.565195	-0.313060	-0.541141	-0.279225
11	-0.201014	-0.280428	-0.547485	-0.311526	-0.524181	-0.279016
12	-0.195280	-0.270412	-0.531806	-0.309676	-0.509167	-0.278327
13	-0.190149	-0.261537	-0.517782	-0.307632	-0.495738	-0.277312
14	-0.185517	-0.253598	-0.505129	-0.305476	-0.483622	-0.276076
15	-0.181306	-0.246440	-0.493630	-0.303263	-0.472611	-0.274693
16	-0.177453	-0.239941	-0.483111	-0.301026	-0.462539	-0.273209
17	-0.173908	-0.234005	-0.473435	-0.298793	-0.453274	-0.271664
18	-0.170630	-0.228553	-0.464491	-0.296580	-0.444710	-0.270083
19	-0.167586	-0.223523	-0.456186	-0.294396	-0.436758	-0.268483
20	-0.164748	-0.218862	-0.448446	-0.292251	-0.429346	-0.266878
21	-0.162093	-0.214526	-0.441205	-0.290148	-0.422413	-0.265278
22	-0.159601	-0.210479	-0.434411	-0.288091	-0.415908	-0.263690
23	-0.157256	-0.206689	-0.428017	-0.286081	-0.409786	-0.262119
24	-0.155042	-0.203130	-0.421983	-0.284120	-0.404009	-0.260571
25	-0.152948	-0.199778	-0.416276	-0.282206	-0.398544	-0.259045
26	-0.150963	-0.196616	-0.410866	-0.280340	-0.393365	-0.257546
27	-0.149077	-0.193623	-0.405726	-0.278520	-0.388443	-0.256073
28	-0.147282	-0.190787	-0.400835	-0.276746	-0.383363	-0.254628
29	-0.145571	-0.188093	-0.396171	-0.275016	-0.379295	-0.253210
30	-0.143936	-0.185530	-0.391717	-0.273330	-0.375030	-0.251821
31	-0.142372	-0.183087	-0.387456	-0.271687	-0.370950	-0.250461
32	-0.140874	-0.180755	-0.383375	-0.270079	-0.367043	-0.249124
33	-0.139437	-0.178526	-0.379461	-0.268513	-0.363296	-0.247816

## Bessel and Neumann Functions of Equal Order and Argument—continued.

$\alpha$	$J_{\alpha-1}(\alpha)$	$J_{\alpha}(\alpha)$	$J_{\alpha+1}(\alpha)$	$G_{\alpha-1}(\alpha)$	$G_{\alpha}(\alpha)$	$G_{\alpha+1}(\alpha)$	$-Y_{\alpha-1}(\alpha)$	$-Y_{\alpha}(\alpha)$	$-Y_{\alpha+1}(\alpha)$
34	0.138057		0.170392	0.375702	0.266985		0.359697	0.246536	
35	0.136730		0.174347	0.372088	0.265493		0.356237	0.245281	
36	0.135453		0.172384	0.368609	0.264036		0.352906	0.244051	
37	0.134222		0.170498	0.365256	0.262612		0.349695	0.242846	
38	0.133035		0.168684	0.362023	0.261221		0.346600	0.241665	
39	0.131889		0.166937	0.358900	0.259862		0.343610	0.240509	
40	0.130780		0.165254	0.355883	0.258533		0.340721	0.239375	
41	0.129709		0.163630	0.352965	0.257232		0.337928	0.238262	
42	0.128672		0.162062	0.350140	0.255960		0.335223	0.237172	
43	0.127607		0.160547	0.347403	0.254715		0.332602	0.236101	
44	0.126602		0.159081	0.344750	0.253496		0.330062	0.235053	
45	0.125747		0.157662	0.342177	0.252301		0.327599	0.234023	
46	0.124830		0.156289	0.339678	0.251133		0.325206	0.233014	
47	0.123938		0.154957	0.337251	0.249987		0.322883	0.232023	
48	0.123072		0.153666	0.334892	0.248864		0.320624	0.231049	
49	0.122229		0.152413	0.332598	0.247763		0.318428	0.230094	
50	0.121409		0.151195	0.330365	0.246683		0.316290	0.229155	
55	0.117614		0.145594	0.320031	0.241577		0.306396	0.224698	
60	0.114252		0.140678	0.310880	0.236910		0.297635	0.220601	
65	0.111245		0.136316	0.302694	0.232619		0.289797	0.216816	
70	0.108531		0.132410	0.295307	0.228652		0.282725	0.213302	
75	0.106064		0.128883	0.288592	0.224970		0.276296	0.210028	
80	0.103807		0.125676	0.282448	0.221537		0.270414	0.206967	
85	0.101730		0.122743	0.276797	0.218325		0.265003	0.204095	
90	0.099811		0.120047	0.271573	0.215310		0.260002	0.201393	
95	0.098028		0.117555	0.266721	0.212472		0.255356	0.198844	
100	0.096367		0.115244	0.262200	0.209792		0.251028	0.196432	
110	0.093354		0.111080	0.253999	0.204848		0.243176	0.191970	
120	0.090685		0.107421	0.246738	0.200381		0.236225	0.187927	
130	0.088298		0.104172	0.240241	0.196314		0.230005	0.184237	
140	0.086143		0.101259	0.234379	0.192586		0.224392	0.180847	
150	0.084185		0.098626	0.229050	0.189150		0.219290	0.177716	
160	0.082393		0.096231	0.224175	0.185967		0.214623	0.174811	

*Bessel and Neumann Functions of Equal Order and Argument—continued.*

$\alpha$	$J_{\alpha}(\alpha)$	$J_{\alpha-1}(\alpha)$	$G_{\alpha}(\alpha)$	$G_{\alpha-1}(\alpha)$	$-Y_{\alpha}(\alpha)$	$-Y_{\alpha-1}(\alpha)$
170	0.080747	0.094038	0.219690	0.183006	0.210329	0.172104
180	0.079222	0.092021	0.215543	0.180241	0.206359	0.169573
190	0.077807	0.090156	0.211693	0.177649	0.202673	0.167197
200	0.076488	0.088425	0.208104	0.175212	0.199237	0.164961
220	0.074096	0.085302	0.201597	0.170741	0.193007	0.160852
240	0.071978	0.082556	0.195833	0.166726	0.187489	0.157155
260	0.070083	0.080114	0.190677	0.163091	0.182552	0.153803
280	0.068373	0.077923	0.186025	0.159775	0.178098	0.150741
300	0.066818	0.075942	0.181795	0.156731	0.174049	0.147927
320	0.065396	0.074137	0.177926	0.153922	0.170344	0.145327
340	0.064088	0.072484	0.174366	0.151318	0.166937	0.142915
360	0.062879	0.070962	0.171076	0.148893	0.163786	0.140666
380	0.061756	0.069554	0.168020	0.146625	0.160860	0.138561
400	0.060704	0.068246	0.165171	0.144499	0.158134	0.136587
450	0.058371	0.065342	0.158813	0.139707	0.152045	0.132132
500	0.056358	0.062856	0.153335	0.135526	0.146801	0.128239
550	0.054595	0.060695	0.148537	0.131831	0.142207	0.124795
600	0.053034	0.058792	0.144290	0.128529	0.138142	0.121713
650	0.051638	0.057097	0.140491	0.125551	0.134505	0.118932
700	0.050378	0.055575	0.137063	0.122846	0.131223	0.116403
750	0.049232	0.054196	0.133947	0.120370	0.128240	0.114085
800	0.048185	0.052940	0.131096	0.118093	0.125510	0.111956
850	0.047221	0.051788	0.128473	0.115986	0.122999	0.109982
900	0.046330	0.050727	0.126049	0.114030	0.120678	0.108149
950	0.045502	0.049744	0.123798	0.112205	0.118523	0.106438
1,000	0.044731	0.048830	0.121699	0.110497	0.116513	0.104836
1,100	0.043332	0.047180	0.117893	0.107382	0.112870	0.101912
1,200	0.042093	0.045724	0.114523	0.104605	0.109643	0.099304
1,300	0.040985	0.044428	0.111508	0.102106	0.106756	0.096955
1,400	0.039985	0.043262	0.108787	0.099840	0.104152	0.094825
1,500	0.039076	0.042206	0.106314	0.097769	0.101784	0.092876
1,600	0.038244	0.041243	0.104051	0.095867	0.099617	0.091086

Bessel and Neumann Functions of Equal Order and Argument—continued.

$\alpha$	$J_{\alpha}(\alpha)$	$J_{\alpha-1}(\alpha)$	$G_{\alpha}(\alpha)$	$G_{\alpha-1}(\alpha)$	$-Y_{\alpha}(\alpha)$	$-Y_{\alpha-1}(\alpha)$
1,700	0.037479	0.040359	0.101970	0.094110	0.097625	0.089431
1,800	0.036772	0.039544	0.100045	0.092480	0.095782	0.087896
1,900	0.036115	0.038790	0.098258	0.090961	0.094071	0.086464
2,000	0.035503	0.038087	0.096592	0.089541	0.092477	0.085125
2,500	0.032958	0.035186	0.089668	0.083593	0.085848	0.079514
3,000	0.031015	0.032988	0.084381	0.079002	0.080786	0.075178
3,500	0.029461	0.031241	0.080155	0.075302	0.076740	0.071680
4,000	0.028179	0.029808	0.076665	0.072226	0.073399	0.068770
4,500	0.027094	0.028600	0.073714	0.069610	0.070573	0.066294
5,000	0.026159	0.027563	0.071169	0.067345	0.068137	0.064150
6,000	0.024616	0.025860	0.066973	0.063586	0.064120	0.060588
7,000	0.023383	0.024505	0.063619	0.060563	0.060908	0.057722
8,000	0.022365	0.023392	0.060849	0.058054	0.058257	0.055342
9,000	0.021504	0.022453	0.058507	0.055922	0.056014	0.053319
10,000	0.020762	0.021647	0.056488	0.054078	0.054081	0.051568
11,000	0.020113	0.020943	0.054721	0.052460	0.052389	0.050032
12,000	0.019538	0.020321	0.053157	0.051023	0.050892	0.048667
13,000	0.019024	0.019766	0.051757	0.049735	0.049552	0.047443
14,000	0.018559	0.019266	0.050494	0.048570	0.048343	0.046336
15,000	0.018137	0.018813	0.049346	0.047508	0.047244	0.045327
16,000	0.017751	0.018398	0.048296	0.046535	0.046238	0.044402
17,000	0.017396	0.018018	0.047330	0.045639	0.045313	0.043550
18,000	0.017068	0.017666	0.046437	0.044809	0.044458	0.042761
19,000	0.016763	0.017340	0.045607	0.044037	0.043664	0.042027
20,000	0.016479	0.017036	0.044834	0.043317	0.042924	0.041342
25,000	0.015298	0.015778	0.041620	0.040313	0.039847	0.038484
30,000	0.014396	0.014821	0.039166	0.038008	0.037497	0.036290
40,000	0.013079	0.013431	0.035585	0.034629	0.034069	0.033072
50,000	0.012142	0.012444	0.033034	0.032211	0.031626	0.030768
100,000	0.009637	0.009828	0.026219	0.025701	0.025102	0.024562
500,000	0.005636	0.005699	0.015333	0.015160	0.014680	0.014499
1,000,000	0.004473	0.004514	0.012170	0.012058	0.011651	0.011535

## PART III.

*Bessel Functions of Half-Integral Order.*

Some progress has been made with the calculation of the functions  $S_n(x)$ ,  $C_n(x)$ , &c., tables of which for integral values of  $x$  from 1 to 10 appear in the Report for 1914.

The tables now presented continue the work for  $x=1.1, \dots, 1.9$ . It is hoped that the Tables for  $x=0.1 \dots 0.9$  will be presented in the next Report. In addition the initial functions  $S_0(x)=\sin x$ ,  $C_0(x)=\cos x$  have been calculated to 15 decimal places for  $x=0.1, 0.2, \dots, 10$  in the preceding table (Table III.).

The functions  $S_n(x)$ ,  $C_n(x)$  are solutions of the differential equation

$$\frac{d^2u_n}{dx^2} + \left\{ 1 - \frac{n(n+1)}{x^2} \right\} u_n = 0.$$

These have been calculated with  $S'_n(x)$ ,  $C'_n(x)$ , their derivatives with respect to  $x$ , and also the important functions  $|E_n(x)|^2$ ,  $|E'_n(x)|^2$  where

$$\begin{aligned} E_n(x) &= C_n(x) - iS_n(x) \\ E'_n(x) &= C'_n(x) - iS'_n(x). \end{aligned}$$

The logarithms of the functions tabulated are given for the whole range of  $n$ —in the previous tables it was not possible to do this for all values of  $n$ . As before  $|E_n(x)|^2$  and  $|E'_n(x)|^2$  are given until  $\{S_n(x)\}^2$  and  $\{S'_n(x)\}^2$  become negligible.

Several misprints occur in the tables published in the Report for 1914. The most serious are  $|E_{13}(9)|^2$  and  $|E_{14}(9)|^2$ , which should be respectively 334.4745 and 2189.467. The following are correct:—  
 $S'_6(8) = .0253461$ ,  $C'_0(9) = -.4121185$ ,  $C'_1(9) = -.9456727$ . The logarithms of the following functions should have negative characteristics:—

$$\begin{array}{ll} |S'_n(3)|, n=6 & |C'_n(9)|, n=4 \\ |S'_n(8)|, n=5, 12 & |S_n(10)|, n=2, 11, 16 \\ |S'_n(9)|, n=4, 5, 6, 7, 15, 16 & |S'_n(10)|, n=13. \\ |C_n(9)|, n=3 & \end{array}$$

The functions  $S_n(x)$ ,  $C_n(x)$  are connected with Bessel Functions of Half-Integral Order as follows:—

$$\begin{aligned} S_n(x) &= \sqrt{\frac{1}{2}\pi x} J_{n+\frac{1}{2}}(x) \\ C_n(x) &= (-1)^n \sqrt{\frac{1}{2}\pi x} J_{-n-\frac{1}{2}}(x). \end{aligned}$$

They are not really 'Bessel Functions of Half-Integral Order,' and it is suggested that a more appropriate name for them is that of 'Riccati-Bessel Functions.'

TABLE IV.

*Bessel Functions of Half-Integral Order.*

$n$	$S_n(1.1)$	$C_n(1.1)$	$ E_n(1.1) ^2$	$n$
0	.8912074	.4535961	1.000000	0
1	.3565924	1.303567	1.826446	1
2	.0813173	3.101588	9.626460	2
3	.0130319	12.79456	163.7009	3
4	.0016127	78.31833		4
5	.0001627	627.9918		5
6	.0000138	6201.600		6
7	.0000010	72663.64		7
8	.0000001	984666.3		8

$n$	$S'_n(1.1)$	$C'_n(1.1)$	$ E'_n(1.1) ^2$	$n$
0	.4535961	-.8912074	1.0000000	0
1	.5670325	-.7314652	0.8565672	1
2	.2087427	-.4335683	18.84172	2
3	.0457759	-.31.79266	1010.776	3
4	.0071676	-.271.9994		4
5	.0008733	-.2776.190		5
6	.0000871	-.33198.92		6
7	.0000074	-.456203.4		7
8	.0000005	-.7088545.		8

$n$	$\log  S_n(1.1) $	$\log  C_n(1.1) $	$\log  E_n(1.1) ^2$	$n$
0	$\bar{1}.9499788$	$\bar{1}.6566693$	0.0000000	0
1	$\bar{1}.5521721$	0.1151335	0.2616069	1
2	$\bar{2}.9101831$	0.4915841	0.9834666	2
3	$\bar{2}.1150063$	1.1070253	2.2140511	3
4	$\bar{3}.2075434$	1.8938634		4
5	$\bar{4}.2112570$	2.4434492		5
6	$\bar{5}.1414226$	4.5211239		6
7	$\bar{6}.0087975$	5.6591585		7
8	$\bar{8}.8213762$	6.8505571		8

$n$	$\log  S'_n(1.1) $	$\log  C'_n(1.1) $	$\log  E'_n(1.1) ^2$	$n$
0	$\bar{1}.6566693$	$\bar{1}.9499788$	0.0000000	0
1	$\bar{1}.7536079$	$\bar{1}.8641937$	$\bar{1}.9327614$	1
2	$\bar{1}.3196113$	0.6370575	1.2751206	2
3	$\bar{2}.6606370$	1.5023269	3.0046548	3
4	$\bar{3}.8553756$	2.4345679		4
5	$\bar{4}.9411828$	3.4434492		5
6	$\bar{5}.9400699$	3.7925037		6
7	$\bar{6}.8865989$	4.8613172		7
8	$\bar{7}.7311326$	5.9932891		8



*Bessel Functions of Half-Integral Order—continued.*

$n$	$S_n(1.2)$	$C_n(1.2)$	$ E_n(1.2) ^2$	$n$
0	·9320391	·3623578	1·000000	0
1	·4143415	1·234004	1·694444	1
2	·1038146	2·722652	7·423611	2
3	·0182194	10·11038	102·2201	3
4	·0024655	56·25456		4
5	·0002717	411·7988		5
6	·0000253	3718·568		6
7	·0000020	39872·69		7
8	·0000001	494690·0		8

$n$	$S'_n(1.2)$	$C'_n(1.2)$	$ E'_n(1.2) ^2$	$n$
0	·3623578	—·9320391	1·0000000	0
1	·5867545	—·6659788	0·7878086	1
2	·2413171	—3·303749	10·97299	2
3	·0582660	—22·55330	508·6546	3
4	·0100012	—177·4048		4
5	·0013333	—1659·574		5
6	·0001454	—18181·04		6
7	·0000134	—228872·1		7
8	·0000011	—3258061·		8

$n$	$\log  S_n(1.2) $	$\log  C_n(1.2) $	$\log  E_n(1.2) ^2$	$n$
0	$\bar{1}$ ·9694341	$\bar{1}$ ·5591376	0·0000000	0
1	$\bar{1}$ ·6173584	0·0913165	0·2290273	1
2	$\bar{1}$ ·0162585	0·4349921	0·8706152	2
3	$\bar{2}$ ·2605352	1·0047674	2·0095363	3
4	$\bar{3}$ ·3919031	1·7501577		4
5	$\bar{4}$ ·4341202	2·6146851		5
6	$\bar{5}$ ·4025955	3·5703757		6
7	$\bar{6}$ ·3081560	4·6006755		7
8	$\bar{7}$ ·1588359	5·6943332		8

$n$	$\log  S'_n(1.2) $	$\log  C'_n(1.2) $	$\log  E'_n(1.2) ^2$	$n$
0	$\bar{1}$ ·5591376	1·9694341	0·0000000	0
1	$\bar{1}$ ·7684564	$\bar{1}$ ·8234604	$\bar{1}$ ·8964207	1
2	$\bar{1}$ ·3825881	0·5190071	1·0403251	2
3	$\bar{2}$ ·7654152	1·3532100	2·7064229	3
4	$\bar{2}$ ·0000500	2·2489654		4
5	$\bar{3}$ ·1249364	3·2199966		5
6	$\bar{4}$ ·1624806	4·2596187		6
7	$\bar{5}$ ·1274209	5·3595929		7
8	$\bar{6}$ ·0302111	6·5129592		8

*Bessel Functions of Half-Integral Order—continued.*

$n$	$S_n(1.3)$	$C_n(1.3)$	$ E_n(1.3) ^2$	$n$
0	·9635582	·2674988	1·0000000	0
1	·4736998	1·169327	1·591716	1
2	·1295951	2·430947	5·926298	2
3	·0247431	8·180470	66·92069	3
4	·0036368	41·61774		4
5	·0004350	279·9423		5
6	·0000439	2327·125		6
7	·0000038	22991·31		7
8	·0000003	262957·2		8

$n$	$S'_n(1.3)$	$C'_n(1.3)$	$ E'_n(1.3) ^2$	$n$
0	·2674988	—·9635582	1·0000000	0
1	·5991737	—·6319831	0·7584118	1
2	·2743226	—2·570592	6·683196	2
3	·0724957	—16·44706	270·5110	3
4	·0135528	—119·8741		4
5	·0019638	—1035·083		5
6	·0002325	—10460·63		6
7	·0000233	—121472·2		7
8	·0000020	—1595207·		8

$n$	$\log  S_n(1.3) $	$\log  C_n(1.3) $	$\log  E_n(1.3) ^2$	$n$
0	$\bar{1}$ ·9838779	1·4273219	0·0000000	0
1	$\bar{1}$ ·6755032	0·0679358	0·2018656	1
2	$\bar{1}$ ·1125887	0·3857755	0·7727835	2
3	$\bar{2}$ ·3934538	0·9127782	1·8255604	3
4	$\bar{3}$ ·5607234	1·6192784		4
5	$\bar{4}$ ·6384829	2·4470686		5
6	$\bar{5}$ ·6422886	3·3668197		6
7	$\bar{6}$ ·5830439	4·3615637		7
8	$\bar{7}$ ·4688264	5·4198850		8

$n$	$\log  S'_n(1.3) $	$\log  C'_n(1.3) $	$\log  E'_n(1.3) ^2$	$n$
0	$\bar{1}$ ·4273219	$\bar{1}$ ·9838779	0·0000000	0
1	$\bar{1}$ ·7775528	$\bar{1}$ ·8007055	$\bar{1}$ ·8799051	1
2	$\bar{1}$ ·4382616	0·4100331	0·8249842	2
3	$\bar{2}$ ·8603124	1·2160883	2·4321850	3
4	$\bar{2}$ ·1320299	2·0787254		4
5	$\bar{3}$ ·2930930	3·0149754		5
6	$\bar{4}$ ·3663487	4·0195580		6
7	$\bar{5}$ ·3667311	5·0844770		7
8	$\bar{6}$ ·3047935	6·2028170		8

*Bessel Functions of Half-Integral Order—continued.*

$n$	$S_n(1.4)$	$C_n(1.4)$	$ E^n(1.4) ^2$	$n$
0	·9854497	·1699671	1·000000	0
1	·5339255	1·106855	1·510204	1
2	·1586764	2·201865	4·873386	2
3	·0327759	6·756947	45·65741	3
4	·0052029	31·58287	997·4779	4
5	·0006715	196·2758		5
6	·0000731	1510·584		6
7	·0000069	13830·58		7
8	·0000006	146674·2		8

$n$	$S'_n(1.4)$	$C'_n(1.4)$	$ E'_n(1.4) ^2$	$n$
0	·1699671	—·9854497	1·0000000	0
1	·6040744	—·6206435	0·7501041	1
2	·3072450	—2·038666	4·250559	2
3	·0884424	—12·27731	150·7401	3
4	·0179104	—83·47983	6968·883	4
5	·0028048	—669·4021		5
6	·0003584	—6277·656		6
7	·0000387	—67642·30		7
8	·0000036	—824307·5		8

$n$	$\log  S_n(1.4) $	$\log  C_n(1.4) $	$\log  E_n(1.4) ^2$	$n$
0	$\bar{1}$ ·9936345	$\bar{1}$ ·2303650	0·0000000	0
1	$\bar{1}$ ·7274807	0·0440907	0·1790356	1
2	$\bar{1}$ ·2005123	0·3427906	0·6878308	2
3	$\bar{2}$ ·5155541	0·8297505	1·6595113	3
4	$\bar{3}$ ·7162472	1·4994516	2·9989033	4
5	$\bar{4}$ ·8270381	2·2928668		5
6	$\bar{5}$ ·8636444	3·1791449		6
7	$\bar{6}$ ·8370529	4·1408403		7
8	$\bar{7}$ ·7553885	5·1663536		8

$n$	$\log  S'_n(1.4) $	$\log  C'_n(1.4) $	$\log  E'_n(1.4) ^2$	$n$
0	$\bar{1}$ ·2303650	$\bar{1}$ ·9936345	0·0000000	0
1	$\bar{1}$ ·7810904	$\bar{1}$ ·7928422	$\bar{1}$ ·8751216	1
2	$\bar{1}$ ·4874848	0·3093461	0·6284460	2
3	$\bar{2}$ ·9466605	1·0891032	2·1782289	3
4	$\bar{2}$ ·2531046	1·9215816	3·8431631	4
5	$\bar{3}$ ·4478942	2·8256871		5
6	$\bar{4}$ ·5543666	3·7977975		6
7	$\bar{5}$ ·5876714	4·8302184		7
8	$\bar{6}$ ·5584714	5·9160893		8

*Bessel Functions of Half-Integral Order—continued.*

$n$	$S_n(1.5)$	$C_n(1.5)$	$ E_n(1.5) ^2$	$n$
0	.9974950	.0707372	1.000000	0
1	.5942595	1.044653	1.444444	1
2	.1910239	2.018569	4.111111	2
3	.0424870	5.683910	32.30864	3
4	.0072486	24.50635	600.5610	4
5	.0010044	141.3542		5
6	.0001173	1012.091		6
7	.0000118	8630.100		7
8	.0000011	85288.91		8
9	.0000001	957977.5		9

$n$	$S'_n(1.5)$	$C'_n(1.5)$	$ E'_n(1.5) ^2$	$n$
0	.0707372	-.9974950	1.0000000	0
1	.6013220	-.6256982	0.7530864	1
2	.3395609	-1.646772	2.827160	2
3	.1060500	-9.349252	87.41975	3
4	.0231575	-59.66635	3560.073	4
5	.0039005	-446.6742		5
6	.0005354	-3907.009		6
7	.0000620	-39261.71		7
8	.0000062	-446244.1		8
9	.0000006	-5662576.		9

$n$	$\log  S_n(1.5) $	$\log  C_n(1.5) $	$\log  E_n(1.5) ^2$	$n$
0	$\bar{1}$ .9989107	$\bar{2}$ .8496479	0.0000000	0
1	$\bar{1}$ .7739761	0.0189721	0.1597008	1
2	$\bar{1}$ .2810878	0.3050436	0.6139592	2
3	$\bar{2}$ .6282557	0.7546472	1.5093187	3
4	$\bar{3}$ .8602521	1.3892786	2.7785572	4
5	3.0019201	2.1503086		5
6	4.0691536	3.0052195		6
7	5.0730299	3.9360158		7
8	6.0217255	4.9308926		8
9	8.9215307	5.9813553		9

$n$	$\log  S'_n(1.5) $	$\log  C'_n(1.5) $	$\log  E'_n(1.5) ^2$	$n$
0	$\bar{2}$ .8496479	$\bar{1}$ .9989107	0.0000000	0
1	$\bar{1}$ .7791071	$\bar{1}$ .7963649	$\bar{1}$ .8768448	1
2	$\bar{1}$ .5309177	0.2166335	0.4513504	2
3	$\bar{1}$ .0255107	0.9707768	1.9416096	3
4	$\bar{2}$ .3646908	1.7757294	3.5514589	4
5	$\bar{3}$ .5911161	2.6499909		5
6	4.7286677	3.5918444		6
7	5.7927320	4.5939692		7
8	6.7940914	5.6495725		8
9	7.7407389	6.7530141		9

*Bessel Functions of Half-Integral Order—continued.*

$n$	$S_n(1.6)$	$C_n(1.6)$	$ E_n(1.6) ^2$	$n$
0	·9995736	—·0291995	1·000000	0
1	·6539330	·9813239	1·390625	1
2	·2265508	1·869182	3·545166	2
3	·0540383	4·859869	23·62125	3
4	·0098667	19·39275	376·0787	4
5	·0014617	104·2243		5
6	·0001823	697·1495		6
7	·0000196	5560·116		7
8	·0000019	51428·93		8
9	·0000002	540872·3		9

$n$	$S'_n(1.6)$	$C'_n(1.6)$	$ E'_n(1.6) ^2$	$n$
0	—·0291995	—·9995736	1·0000000	0
1	·5908655	—·6425270	0·7619629	1
2	·3707445	—1·355153	1·973892	2
3	·1252290	—7·243073	52·47779	3
4	·0293716	—43·62200	1902·887	4
5	·0052989	—306·3083		5
6	·0007780	—2510·086		6
7	·0000964	—23628·36		7
8	·0000103	—251584·6		8
9	·0000010	—2990978·		9

$n$	$\log  S_n(1.6) $	$\log  C_n(1.6) $	$\log  E_n(1.6) ^2$	$n$
0	$\bar{1}$ ·9998148	$\bar{2}$ ·4653757	0·0000000	0
1	$\bar{1}$ ·8155333	$\bar{1}$ ·9918124	0·1432100	1
2	$\bar{1}$ ·3551656	0·2716516	0·5496366	2
3	$\bar{2}$ ·7327015	0·6866246	1·3733029	3
4	$\bar{3}$ ·9941701	1·2876393	2·5752787	4
5	$\bar{3}$ ·1648490	2·0179691		5
6	$\bar{4}$ ·2608239	2·8433259		6
7	$\bar{5}$ ·2932701	3·7450838		7
8	$\bar{6}$ ·2704195	4·7112075		8
9	$\bar{7}$ ·1985963	5·7330947		9

$n$	$\log  S'_n(1.6) $	$\log  C'_n(1.6) $	$\log  E'_n(1.6) ^2$	$n$
0	$\bar{2}$ ·4653757	$\bar{1}$ ·9998148	0·0000000	0
1	$\bar{1}$ ·7714886	$\bar{1}$ ·8078914	$\bar{1}$ ·8819338	1
2	$\bar{1}$ ·5690747	0·1319885	0·2953234	2
3	$\bar{1}$ ·0977051	0·8599229	1·7199756	3
4	$\bar{2}$ ·4679281	1·6397055	3·2794131	4
5	$\bar{3}$ ·7241892	2·4861588		5
6	$\bar{4}$ ·8909713	3·3996887		6
7	$\bar{5}$ ·9839202	4·3734335		7
8	$\bar{5}$ ·0139483	5·4006840		8
9	$\bar{7}$ ·9891208	6·4758132		9

*Bessel Functions of Half-Integral Order—continued.*

$n$	$S_n(1.7)$	$C_n(1.7)$	$ E_n(1.7) ^2$	$n$
0	·9916648	—1288445	1·0000000	0
1	·7121767	·9158740	1·346021	1
2	·2651177	1·745093	3·115636	2
3	·0675811	4·216751	17·78556	3
4	·0131575	15·61800	243·9221	4
5	·0020760	78·46679		5
6	·0002756	492·1083		6
7	·0000316	3684·714		7
8	·0000032	32020·07		8
9	·0000003	316516·0		9

$n$	$S'_n(1.7)$	$C'_n(1.7)$	$ E'_n(1.7) ^2$	$n$
0	—1288445	—·9916648	1·0000000	0
1	·5727373	—·6675939	·07737096	1
2	·4002736	—1·137176	1·453389	2
3	·1458569	—5·696234	32·46835	3
4	·0366224	—32·53149	1058·299	4
5	·0070515	—215·1667		5
6	·0011033	—1658·386		6
7	·0001455	—14680·24		7
8	·0000166	—146998·0		8
9	·0000017	—1643653·		9

$n$	$\log  S_n(1.7) $	$\log  C_n(1.7) $	$\log  E_n(1.7) ^2$	$n$
0	1·9963649	1̄·1100659	0·0000000	0
1	1̄·8525878	1̄·9618357	0·1290518	1
2	1̄·4234387	0·2418185	0·4935467	2
3	2̄·8298253	0·6249780	1·2500675	3
4	2̄·1191719	1·1936255	2·3872512	4
5	3̄·3172314	1·8946859		5
6	4̄·4402972	2·6920607		6
7	5̄·4996503	3·5664038		7
8	6̄·5035823	4·5054223		8
9	7̄·4584539	5·5003957		9

$n$	$\log  S'_n(1.7) $	$\log  C'_n(1.7) $	$\log  E'_n(1.7) ^2$	$n$
0	1̄·1100659	1̄·9963649	0·0000000	0
1	1̄·7579555	1̄·8245123	1̄·8885780	1
2	1̄·6023569	0·0558278	0·1623818	2
3	1̄·1639270	0·7555878	1·5114602	3
4	2̄·5637466	1·5123039	3·0246084	4
5	3̄·8482825	2·3327750		5
6	3̄·0426831	3·2196856		6
7	4̄·1628774	4·1667333		7
8	5̄·2199186	5·1673114		8
9	6̄·2219501	6·2158101		9

*Bessel Functions of Half-Integral Order—continued.*

$n$	$S_n(1.8)$	$C_n(1.8)$	$ E_n(1.8) ^2$	$n$
0	·9738476	—·2272021	1·0000000	0
1	·7682286	·8476242	1·308642	1
2	·3065333	1·639909	2·783265	2
3	·0832528	3·707679	13·75381	3
4	·0172277	12·77884	163·2991	4
5	·0028856	60·18653		5
6	·0004064	355·0278		6
7	·0000494	2503·903		7
8	·0000053	20510·83		8
9	·0000005	191209·5		9

$n$	$S'_n(1.8)$	$C'_n(1.8)$	$ E'_n(1.8) ^2$	$n$
0	—·2272021	—·9738476	1·0000000	0
1	·5470540	—·6981045	0·7866179	1
2	·4276360	—·9744971	1·132517	2
3	·1677786	—4·539556	20·63572	3
4	·0449691	—24·68975	609·5837	4
5	·0092122	—154·4060		5
6	·0015310	—1123·239		6
7	·0002143	—9382·372		7
8	·0000259	—88655·34		8
9	·0000028	—935536·6		9

$n$	$\log  S_n(1.8) $	$\log  C_n(1.8) $	$\log  E_n(1.8) ^2$	$n$
0	$\bar{1}$ ·9884910	$\bar{1}$ ·3564123	0·0000000	0
1	$\bar{1}$ ·8854904	$\bar{1}$ ·9282034	0·1168208	1
2	$\bar{1}$ ·4864777	0·2148198	0·4445545	2
3	$\bar{2}$ ·9203990	0·5691021	1·1384231	3
4	$\bar{2}$ ·2362268	1·1064915	2·2129838	4
5	$\bar{3}$ ·4602321	1·7794993		5
6	$\bar{4}$ ·6089333	2·5502623		6
7	$\bar{5}$ ·6937251	3·3986175		7
8	$\bar{6}$ ·7229634	4·3119832		8
9	$\bar{7}$ ·7030474	5·2815094		9

*Bessel Functions of Half-Integral Order*—continued.

$n$	$\log  S_n'(1.8) $	$\log  C_n'(1.8) $	$\log  E_n'(1.8) ^2$	$n$
0	$\bar{1}$ .3564123	$\bar{1}$ .9884910	0.0000000	0
1	$\bar{1}$ .7380302	$\bar{1}$ .8439204	$\bar{1}$ .8957638	1
2	$\bar{1}$ .6310743	$\bar{1}$ .9887805	0.0540448	2
3	$\bar{1}$ .2247366	0.6570134	1.3146196	3
4	$\bar{2}$ .6529141	1.3925167	2.7850333	4
5	$\bar{3}$ .9643632	2.1886641		5
6	$\bar{3}$ .1849668	3.0504723		6
7	$\bar{4}$ .3309626	3.9723126		7
8	$\bar{5}$ .4135565	4.9477049		8
9	$\bar{6}$ .4409759	5.9710608		9

$n$	$S_n(1.9)$	$C_n(1.9)$	$ E_n(1.9) ^2$	$n$
0	.9463001	— .3232896	1.000000	0
1	.8213422	.7761477	1.277008	1
2	.3505561	1.548786	2.521627	2
3	.1011738	3.299605	10.89763	3
4	.0221894	10.60765	112.5228	4
5	.0039339	46.94717		5
6	.0005860	261.1918		6
7	.0000753	1740.154		7
8	.0000085	13476.87		8
9	.0000009	118842.4		9
10	.0000001	1174947.		10

$n$	$S_n'(1.9)$	$C_n'(1.9)$	$ E_n'(1.9) ^2$	$n$
0	— .3232896	— .9463001	1.0000000	0
1	.5140147	— .7317883	0.7997253	1
2	.4523358	— .8541533	0.9341855	2
3	.1908080	— 3.661116	13.44018	3
4	.0544592	— 19.03230	362.2312	4
5	.0118370	— 112.9375		5
6	.0020835	— 777.8689		6
7	.0003085	— 6149.903		7
8	.0000395	— 55004.56		8
9	.0000044	— 549460.6		9
10	.0000004	— 6065087.		10



*Bessel Functions of Half-Integral Order* – continued.

$n$	$\log  S_n(1.9) $	$\log  C_n(1.9) $	$\log  E_n(1.9) ^2$	$n$
0	1.9760289	1.5095917	0.0000000	0
1	1.9145242	1.8899444	0.1061937	1
2	1.5447575	0.1899914	0.4016809	2
3	1.0050680	0.5184619	1.0373320	3
4	2.3461456	1.0256193	2.0512405	4
5	3.5948263	1.6716094		5
6	4.7678710	2.4169595		6
7	5.8767966	3.2405878		7
8	6.9300277	4.1295890		8
9	7.9340049	5.0749712		9
10	8.8938182	6.0700182		10

$n$	$\log  S_n'(1.9) $	$\log  C_n'(1.9) $	$\log  E_n'(1.9) ^2$	$n$
0	1.5095917	1.9760289	0.0000000	0
1	1.7109755	1.8643855	1.9029408	1
2	1.6554610	1.9315358	1.9704331	2
3	1.2805966	0.5636135	1.1284051	3
4	2.7360716	1.2794912	2.5589859	4
5	2.0732403	2.0528383		5
6	3.3187965	2.8909064		6
7	4.4893142	3.7888683		7
8	5.5961638	4.7403987		8
9	6.6476631	5.7399366		9
10	7.6501758	6.7828371		10

## PART IV.

*Tables of the ber, bei, ker, kei, &c. functions—(continued).*

*Introductory Note.*

§ 1. *Definitions* (Kelvin, 'Math. and Phys. Papers,' vol. iii. p. 491; Russell's 'Alternating Currents,' 2nd ed., vol. i., chap. 7).

$$\begin{aligned} \text{ber } x + i \text{ bei } x &= I_0(x\sqrt{i}) & (i = \sqrt{-1}) \\ \text{ber } x - i \text{ bei } x &= J_0(x\sqrt{i}) \\ \text{ker } x + i \text{ kei } x &= K_0(x\sqrt{i}) \\ \text{ker } x - i \text{ kei } x &= G_0(x\sqrt{i}) \end{aligned}$$

§ 2. *Expansions*

*In series of ascending powers.*

$$\begin{aligned} \text{ber } x &= 1 - \frac{x^4}{2^2 \cdot 4^2} + \frac{x^8}{(2 \cdot 4 \cdot 6 \cdot 8)^2} + \dots & \text{bei } x &= \frac{x^2}{2^2} - \frac{x^6}{(2 \cdot 4 \cdot 6)^2} + \dots \\ \text{ker } x &= (a - \log x) \text{ber } x + \frac{\pi}{4} \text{bei } x - \frac{3}{2} \frac{x^4}{2^2 \cdot 4^2} + \frac{50}{24} \frac{x^8}{2 \cdot 4 \cdot 6 \cdot 8)^2} - \dots \\ \text{kei } x &= (a - \log x) \text{bei } x - \frac{\pi}{4} \text{ber } x + \frac{x^2}{2^2} - \frac{11}{6} \cdot \frac{x^6}{(2 \cdot 4 \cdot 6)^2} + \dots \end{aligned}$$

general term,

$$\sum_{r=1}^{r=s} \left( \frac{1}{r} \right) \frac{x^{2s}}{(2 \cdot 4 \dots 2s)^2} \quad a = \log_e 2 - \gamma = \cdot 1159315. \dots$$

§ 3. *In semi-divergent series of descending powers.*

These are obtained from  $I_n(x) = (2\pi x)^{-\frac{1}{2}} \exp\left(x + \frac{m}{x} + \frac{m}{2x^2} + \frac{3m+m^2}{6x^3} + \frac{3m+2m^2}{4x^4} + \frac{15m+14m^2+m^3}{10x^5} + \frac{45m+51m^2+8m^3}{12x^6} + \frac{630m+807m^2+190m^3+5m^4}{56x^7} + \frac{315m+438m^2+132m^3+8m^4}{8x^8} + \frac{11840m+16704m^2+5925m^3+560m^4+7m^5}{72x^9} + \frac{14175m+21780m^2+8655m^3+1080m^4+32m^5}{20x^{10}} + \dots\right)$

where

$$m = \frac{1 - 4n^2}{8}.$$

(To derive these coefficients put in Bessel's equation for  $I_n x$ , viz.:  $y'' + \frac{1}{x} y' - y\left(1 + \frac{n^2}{x^2}\right) = 0$ ;  $y = \exp\left(\int u \cdot dx\right)$ , whence  $u^2 + u' + \frac{1}{x}u - \left(1 + \frac{n^2}{x^2}\right) = 0$ ; from this the coefficients are readily deduced.)

From this expansion, putting  $x\sqrt{i}$  for  $x$  and  $n=0$ , ber  $x=(2\pi x)^{-\frac{1}{2}}e^x \cos \beta$  and bei  $x=(2\pi x)^{-\frac{1}{2}}e^x \sin \beta$ , where

$$\alpha = \frac{x}{\sqrt{2}} + \frac{1}{8\sqrt{2}x} - \frac{25}{384\sqrt{2}x^3} - \frac{13}{128x^4} - \frac{1073}{5120\sqrt{2}x^5} - \frac{375733}{229376\sqrt{2}x^7} \\ + \frac{23797}{4096x^8} + \dots$$

$$\beta = \frac{x}{\sqrt{2}} - \frac{\pi}{8} - \frac{1}{8\sqrt{2}x} - \frac{1}{16x^2} - \frac{25}{384\sqrt{2}x^3} + \frac{1073}{5120\sqrt{2}x^5} + \frac{103}{192x^6} \\ + \frac{375733}{229376\sqrt{2}x^7} - \dots$$

Putting  $x\sqrt{i}$  for  $x$  and  $n=1$  since  $I'_0(x)=I_1(x)$ , ber'  $x=(2\pi x)^{-\frac{1}{2}}e^x \cos \phi$  and bei'  $x=(2\pi x)^{-\frac{1}{2}}e^x \sin \phi$  where

$$\eta = \frac{x}{\sqrt{2}} - \frac{3}{8\sqrt{2}x} - \frac{21}{128\sqrt{2}x^3} + \frac{27}{128x^4} + \frac{1899}{5120\sqrt{2}x^5} - \frac{543483}{229376\sqrt{2}x^7} \\ - \frac{32427}{4096x^8} - \dots$$

$$\phi = \frac{x}{\sqrt{2}} + \frac{\pi}{8} + \frac{3}{8\sqrt{2}x} + \frac{3}{16x^2} + \frac{21}{128\sqrt{2}x^3} - \frac{1899}{5120\sqrt{2}x^5} - \frac{27}{32x^6} \\ - \frac{543483}{229376\sqrt{2}x^7} + \dots$$

The corresponding series for ker  $x$ , kei  $x$ , &c., are obtained by putting  $-x$  for  $x$  and  $\left(\frac{\pi}{2x}\right)^{\frac{1}{2}} \cos n\pi$  for  $(2\pi x)^{-\frac{1}{2}}$

#### § 4. The 'Product Functions.'

In practical problems the functions usually appear in certain combinations. For the ber and bei functions they are as follows:

$$\begin{aligned} Xb^*(x) &= \text{ber}^2 x + \text{bei}^2 x &&= I_0(x\sqrt{i}) J_0(x\sqrt{i}) \\ Vb(x) &= \text{ber}'^2 x + \text{bei}'^2 x &&= I'_0(x\sqrt{i}) J'_0(x\sqrt{i}) \\ Zb(x) &= \text{ber } x \text{ ber}' x + \text{bei } x \text{ bei}' x = \frac{1}{2}(I'_0 J_0 + I_0 J'_0) \\ Wb(x) &= \text{ber } x \text{ bei}' x - \text{bei } x \text{ ber}' x = \frac{1}{2i}(I'_0 J_0 - I_0 J'_0) \end{aligned}$$

(In the last two the argument  $x\sqrt{i}$  is understood for  $I_0$  and  $J_0$ .)

\* This notation is adapted from that in Russell's *Alternating Currents*, second edition, vol. 1, chapter 7.

§ 5. The corresponding combinations of the ker and kei functions are :

$$Xk(x) = \text{ker}^2x + \text{kei}^2x = K_0(x\sqrt{i})G_0(x\sqrt{i})$$

$$Vk(x) = \text{ker}'^2x + \text{kei}'^2x = K'_0G'_0$$

$$Zk(x) = \text{ker } x \text{ ker}'x + \text{kei } x \text{ kei}'x = \frac{1}{2}(K'_0G_0 + K_0G'_0)$$

$$Wk(x) = \text{ker } x \text{ kei}'x - \text{kei } x \text{ ker}'x = \frac{1}{2i}(K'_0G_0 - K_0G'_0).$$

§ 6. Mixed (ber, ker, &c.) product-functions arise from

$$I_0(x\sqrt{i})G_0(x\sqrt{i}) \text{ \&c.}$$

and the real and unreal parts of this product will be called  $Xr(x)$  and  $Xu(x)$ ; and there are corresponding combinations analogous to the V, W, and Z functions already given :

$$\left. \begin{aligned} Xr(x) &= \text{ber } x \text{ ker } x + \text{bei } x \text{ kei } x \\ Xu(x) &= \text{ker } x \text{ bei } x - \text{ber } x \text{ kei } x \end{aligned} \right\} Xr(x) + iXu(x) = I_0(x\sqrt{i})G_0(x\sqrt{i})$$

$$\left. \begin{aligned} Vr(x) &= \text{ber}'x \text{ ker}'x + \text{bei}'x \text{ kei}'x \\ Vu(x) &= \text{ker}'x \text{ bei}'x - \text{ber}'x \text{ kei}'x \end{aligned} \right\} Vr(x) + iVu(x) = I'_0G'_0$$

$$Zr(x) = \frac{1}{2}(\text{ber}'x \text{ ker } x + \text{ber } x \text{ ker}'x + \text{bei}'x \text{ kei } x + \text{bei } x \text{ kei}'x)$$

$$Zu(x) = \frac{1}{2}(\text{ker } x \text{ bei}'x + \text{ker}'x \text{ bei } x - \text{ber}'x \text{ kei } x - \text{ber } x \text{ kei}'x)$$

$$Zr(x) + iZu(x) = \frac{1}{2}(I'_0G_0 + I_0G'_0).$$

$$Wr(x) = \frac{1}{2}(\text{ber } x \text{ kei}'x + \text{ker } x \text{ bei}'x - \text{ber}'x \text{ kei } x - \text{ker}'x \text{ bei } x)$$

$$Wu(x) = \frac{1}{2}(\text{ker}'x \text{ ber } x + \text{bei}'x \text{ kei } x - \text{ber}'x \text{ ker } x - \text{bei}'x \text{ kei } x)$$

$$Wr(x) + iWu(x) = \frac{1}{2i}(I_0G'_0 - I'_0G_0).$$

§ 7. The last four may be simplified by the following relations, which arise from the well-known property of the Bessel functions :—

$$I_0(x)K'_0(x) - I'_0(x)K_0(x) = -\frac{1}{x}.$$

Putting  $x\sqrt{i}$  for  $x$  and equating real and imaginary parts,

$$\text{ber } x \text{ ker}'x + \text{bei}'x \text{ kei } x - \text{ber}'x \text{ ker } x - \text{bei } x \text{ kei}'x = -\frac{1}{x}$$

$$\text{ber } x \text{ kei}'x + \text{bei } x \text{ ker}'x - \text{ber}'x \text{ kei } x - \text{bei}'x \text{ ker } x = 0.$$

§ 8. Hence

$$Zr(x) = \text{ber } x \text{ ker}'x + \text{bei}'x \text{ kei } x + \frac{1}{2x} = \text{ber}'x \text{ ker } x + \text{bei } x \text{ kei}'x - \frac{1}{2x}$$

$$Zu(x) = \ker x \operatorname{bei}'x - \operatorname{ber} x \operatorname{kei}'x = \operatorname{bei} x \operatorname{ker}'x - \operatorname{kei} x \operatorname{ber}'x$$

$$Wr(x) = \operatorname{ber} x \operatorname{kei}'x - \operatorname{ber}'x \operatorname{kei} x = \ker x \operatorname{bei}'x - \operatorname{ker}'x \operatorname{bei} x$$

$$Wu(x) = \ker'x \operatorname{ber} x - \ker x \operatorname{ber}'x + \frac{1}{2x} = \operatorname{bei} x \operatorname{kei}'x - \operatorname{bei}'x \operatorname{kei} x - \frac{1}{2x}.$$

It will be noticed that  $J_0(x\sqrt{i})K_0(x\sqrt{i}) = Xr(x) - iXu(x)$ , &c.

At the present time  $Vr(x)$  and  $Vu(x)$ , called by Dr. Russell\*  $S(x)$  and  $T(x)$  are the only mixed functions which have arisen in practical work, and tables of these two only are included here.

§ 9. As the four X- functions arise from the products  $I_0J_0$ ,  $K_0G_0$ , and  $I_0G_0$  (argument  $x\sqrt{i}$ ), they must each be related in the same way to their derivates; and we shall now show that they are four independent solutions of a linear differential equation of the fourth order; as are also the four V, the four Z, and the four W functions.

§ 10. *Differentiation of the X-, V-, Z-, W- functions.*—The argument  $x$  will be understood: X stands for  $Xb(x)$  or any of the other three X functions, and V, Z, W, for the corresponding V-, Z-, and W- functions.

Noticing that  $\operatorname{ber}''x = -\frac{1}{x} \operatorname{ber}'x - \operatorname{bei} x$  and  $\operatorname{bei}''x = -\frac{1}{x} \operatorname{bei}'x + \operatorname{ber} x$ †

$$X' = 2Z \qquad V' = 2W - \frac{2}{x}V$$

$$Z' = V - \frac{1}{x}Z \qquad W' = X - \frac{1}{x}W.$$

Further differentiation gives:

$$V'' + \frac{3}{x}V' = 2X = 2\left(W' + \frac{1}{x}W\right)$$

multiplying by  $x$  and successively differentiating

$$V^{n+1} + \frac{n+2}{x}V^n = 2X^{n-1} + \frac{n-1}{x}X^{n-2} = 2\left(W^n + \frac{n}{x}W^{n-1}\right).$$

Again  $X'' + \frac{1}{x}X' = 2V$ . Multiplying by  $x$  and successively differentiating

$$X^{n+1} + \frac{n}{x}X^n = 2\left(V^{n-1} + \frac{n-1}{x}V^{n-2}\right).$$

By these relations the successive derivates of X, V, W, and Z (which =  $\frac{1}{2}X'$ ) can be calculated.

\* *Alternating Currents, loc. cit.*

† Or we may obtain our results from  $Xb(x) = I_0(x\sqrt{i})J_0(x\sqrt{i})$ , &c. (§ 4).

§ 11. We can now find the linear differential equation solved by X. By eliminating V and its derivates from

$$\left. \begin{aligned} X^{IV} + \frac{3}{x}X^{III} &= 2(V^{II} + \frac{2}{x}V^I) \\ X^{III} + \frac{2}{x}X^{II} &= 2(V^I + \frac{1}{x}V) \\ X^{II} + \frac{1}{x}X^I &= 2V \\ 2X &= V^{II} + \frac{3}{x}V^I \end{aligned} \right\}$$

we obtain  $x^4.X^{IV} + 4x^3.X^{III} + x^2X^{II} - xX^I - 4x^4X = 0$ .

The corresponding equations for the V, Z, and W functions are :

$$x^4V^{IV} + 4x^3V^{III} - 3x^2V^{II} + 3xV^I - 4x^4V = 0.$$

$$x^4Z^{IV} + 4x^3Z^{III} - 3x^2Z^{II} - 3xZ^I + Z(3 - 4x^4) = 0.$$

$$x^4W^{IV} + 4x^3W^{III} + x^2W^{II} + xW^I - W(1 + 4x^4) = 0.$$

§ 12. These equations afford the best means of determining the coefficients in the expansions in series of the functions. The results are set out here; the appropriate solution is of course determined by multiplying out a few terms of the expansions of ber  $x$ , ker  $x$ , &c.

$$Xb(x) = 1 + \frac{(x/2)^4}{\underline{1} \underline{1} \underline{2}} + \frac{(x/2)^8}{\underline{2} \underline{2} \underline{4}} + \frac{(x/2)^{12}}{\underline{3} \underline{3} \underline{6}} + \dots$$

$$Vb(x) = (x/2)^2 + \frac{(x/2)^6}{\underline{1} \underline{2} \underline{3}} + \frac{(x/2)^{10}}{\underline{2} \underline{3} \underline{5}} + \frac{(x/2)^{14}}{\underline{3} \underline{4} \underline{7}} + \dots$$

$$Zb(x) = \frac{(x/2)^3}{\underline{1} \underline{2}} + \frac{(x/2)^7}{\underline{1} \underline{2} \underline{4}} + \frac{(x/2)^{11}}{\underline{2} \underline{3} \underline{6}} + \frac{(x/2)^{15}}{\underline{3} \underline{4} \underline{8}}$$

$$Wb(x) = (x/2) + \frac{(x/2)^5}{\underline{1} \underline{1} \underline{3}} + \frac{(x/2)^9}{\underline{2} \underline{2} \underline{5}} + \frac{(x/2)^{13}}{\underline{3} \underline{3} \underline{7}} + \dots$$

$$Xu(x) = \frac{\pi}{4} Xb(x) - \left( \frac{x^2}{2^2 \underline{1}} + \frac{x^6}{(2.6)^2 \underline{3}} + \frac{x^{10}}{(2.6.10)^2 \underline{5}} + \dots \right)$$

$$Vu(x) = \frac{\pi}{4} Vb(x) - \frac{1}{2} \left( 1 + \frac{x^4}{2^2 \underline{3}} + \frac{x^8}{(2.6)^2 \underline{5}} + \frac{x^{12}}{(2.6.10)^2 \underline{7}} + \dots \right)$$

$$Zu(x) = \frac{\pi}{4} Zb(x) - \left( \frac{x}{2^2} + \frac{x^5}{(2.6)^2 \underline{2}} + \frac{x^9}{(2.6.10)^2 \underline{4}} + \dots \right)$$

$$Wu(x) = \frac{\pi}{4} Wb(x) - \frac{1}{2} \left( \frac{1}{x} + \frac{x^3}{2^2|2} + \frac{x^7}{(2.6)^2|4} + \frac{x^{11}}{(2.6.10)^2|6} + \dots \right)$$

$$Xr(x) = (\alpha - \log x) Xb(x) + \frac{c_1(x/2)^4}{|1|1|2} + \frac{c_2(x/2)^8}{|2|2|4} + \frac{c_3(x/2)^{12}}{|3|3|6} + \dots, \text{ where}$$

$$c_1 = \frac{5}{4} \quad c_2 = \frac{43}{24} \quad c_3 = \frac{257}{120} \dots \dots \dots c_r = \frac{3}{4} \sum_{s=1}^{s=r} \left( \frac{1}{s} \right) + \frac{1}{2} \sum_{s=1}^{s=r} \left( \frac{1}{2s-1} \right)$$

$$Vr(x) = (\alpha - \log x) Vb(x) + \frac{3}{4} (x/2)^2 + \frac{37}{24} \frac{(x/2)^6}{|1|2|3} + \frac{79}{40} \frac{(x/2)^{10}}{|2|3|5} + \dots$$

The coefficients are  $c_1 - \frac{1}{2}$ ,  $c_2 - \frac{1}{4}$ ,  $c_3 - \frac{1}{6}$ ,  $\dots$

$$Zr(x) = (\alpha - \log x) Zb(x) - \frac{1}{2x} + \frac{(x/2)^3}{|1|2} + \frac{5}{8} \cdot \frac{(x/2)^7}{|1|2|4} + \frac{247}{120} \frac{(x/2)^{11}}{|2|3|6} + \dots$$

The coefficients are  $c_1 - \frac{1}{4}$ ;  $c_2 - \frac{1}{8}$ ;  $c_3 - \frac{1}{12}$ ;  $\dots$

$$Wr(x) = (\alpha - \log x) Wb(x) + \frac{1}{2} (x/2) + \frac{17}{12} \frac{(x/2)^5}{|1|1|3} + \frac{227}{120} \cdot \frac{(x/2)^9}{|2|2|5} + \dots$$

The coefficients are  $c_1 - \frac{3}{4}$ ;  $c_2 - \frac{3}{8}$ ;  $c_3 - \frac{3}{12}$ ;  $\dots$

$$Xk(x) = \left\{ (\alpha - \log x)^2 + \frac{\pi^2}{16} \right\} Xb(x) + 2(\alpha - \log x) \left\{ c_1 \frac{(x/2)^4}{|1|1|2} + c_2 \frac{(x/2)^8}{|2|2|4} \right. \\ \left. + c_3 \frac{(x/2)^{12}}{|3|3|6} + \dots \right.$$

$$\left. - \frac{\pi}{2} \left( \frac{x^2}{2^2|1} + \frac{x^6}{(2.6)^2|3} + \frac{x^{10}}{(2.6.10)^2|5} + \dots \right) + n_1 \frac{(x/2)^4}{|1|1|2} + n_2 \frac{(x/2)^8}{|2|2|4} \right. \\ \left. + n_3 \frac{(x/2)^{12}}{|3|3|6} + \dots \right.$$

where  $n_1 = 2$ ;  $n_2 = \frac{67}{18}$ ;  $n_3 = \frac{18467}{3600}$ ;  $n_4 = \frac{557659}{88200} \dots$

$$n_r = n_{r-1} + \frac{8r-3}{2r(2r-1)} \quad c_r - \frac{3(4r-1)}{8r^2(2r-1)}$$

$$Vk(x) = \left\{ (\alpha - \log x)^2 + \frac{\pi^2}{16} \right\} Vb(x) + 2(\alpha - \log x) \left\{ \frac{3}{4} (x/2)^2 + \frac{37}{24} \frac{(x/2)^6}{|1|2|3} + \dots \right\}$$

$$- \frac{\pi}{4} \left( 1 + \frac{x^4}{2^2|3} + \frac{x^8}{(2.6)^2|5} + \dots \right) + \frac{7}{8} \frac{(x/2)^2}{|1|1} + \frac{823}{288} \frac{(x/2)^6}{|1|2|3} + \dots$$

The new coefficients are  $\left(n_1 - c_1 + \frac{1}{8.1^2}\right)$ ;  $\left(n_2 - \frac{1}{2}c_2 + \frac{1}{8.2^2}\right)$ ;  
 $\left(n_3 - \frac{1}{3}c_3 + \frac{1}{8.3^2}\right) \dots \dots$

$$Zk(x) = \left\{ (a - \log x)^2 + \frac{\pi^2}{16} \right\} Zb(x) + 2(a - \log x) \left\{ -\frac{1}{2x} + \frac{(x/2)^3}{|1|2} \right. \\ \left. + \frac{5}{3} \frac{(x/2)^7}{|1|2|4} + \dots \right\} \\ - \frac{\pi}{2} \left( \frac{x}{2^2} + \frac{x^5}{(2.6)^2|2} + \dots \right) + \frac{11}{8} \frac{(x/2)^3}{|1|2} + \frac{943}{288} \frac{(x/2)^7}{|1|2|4} + \dots$$

The new coefficients are  $\left(n_1 - \frac{1}{2}c_1\right)$ ;  $\left(n_2 - \frac{1}{4}c_2\right)$ ;  $\left(n_3 - \frac{1}{6}c_3\right)$ ;  $\dots \dots$

$$Wk(x) = \left\{ (a - \log x)^2 + \frac{\pi^2}{16} \right\} Wb(x) + 2(a - \log x) \left\{ \frac{1}{2} \frac{(x/2)}{|2} \right. \\ \left. + \frac{17}{12} \frac{(x/2)^5}{|1|1|3} + \dots \right\} \\ - \frac{\pi}{4} \left( \frac{1}{x} + \frac{x^3}{2^2|2} + \frac{x^7}{(2.6)^2|4} + \dots \right) + \frac{1}{2} \frac{(x)}{|2} + \frac{89}{36} \frac{(x/2)^5}{|1|1|3} + \frac{14762}{3600} \frac{(x/2)^9}{|2|2|5} + \dots$$

The new coefficients are  $\left(n_1 - \frac{3}{2}c_1 + \frac{3}{8.1^2}\right)$ ;  $\left(n_2 - \frac{3}{4}c_2 + \frac{3}{8.2^2}\right)$ ;  
 $\left(n_3 - \frac{3}{6}c_3 + \frac{3}{8.3^2}\right) \dots \dots$

### § 13. Expansions in series of descending powers.

From the expansions, in descending powers, of ber  $x$ , &c., we have

$$Xb(x) = \frac{1}{2\pi x} e^{2x} \text{ and } Vb(x) = \frac{1}{2\pi x} e^{2\eta} \text{ (for } a \text{ and } \eta, \text{ see § 3).}$$

$$Zb(x). \text{ Putting } Zb(x) = \frac{C}{x} e^{2x}, \text{ we have } \frac{Zb(x)}{Xb(x)} = 2\pi C e^{2(x-a)}.$$

Now  $e^{2a} = 2\pi x Xb(x)$ . Taking logs and differentiating

$$\frac{Zb(x)}{Xb(x)} = a' - \frac{1}{2x} = \frac{1}{\sqrt{2}} - \frac{1}{2x} - \frac{1}{8\sqrt{2}x^2} + \frac{25}{128\sqrt{2}x^4} + \frac{13}{32x^5} + \frac{1073}{1024\sqrt{2}x^6} - \dots$$

$$\text{Then putting } C = \frac{1}{2\sqrt{2}\pi}, \quad 2(\xi - a) = \log \left( 1 - \frac{1}{x\sqrt{2}} - \frac{1}{8x^2} + \frac{25}{128x^4} \right. \\ \left. + \frac{13}{16\sqrt{2}x^5} + \dots \right).$$



From this, by expanding the logarithm, we obtain

$$Zb(x) = \frac{1}{2\sqrt{2}\pi x} e^{2x}, \text{ where } \zeta = \frac{x}{\sqrt{2}} - \frac{3}{8\sqrt{2}x} - \frac{3}{16x^2} - \frac{27}{128\sqrt{2}x^3} - \frac{9}{128x^4} \\ + \frac{1179}{5120\sqrt{2}x^5} + \frac{387}{512x^6} + \dots$$

$Wb(x)$ . We have  $\beta = \arctan \frac{\text{bei } x}{\text{ber } x}$ . Differentiating

$$\frac{Wb(x)}{Xb(x)} = \beta' = \frac{1}{\sqrt{2}} + \frac{1}{8\sqrt{2}x^2} + \frac{1}{8x^3} + \frac{25}{128\sqrt{2}x^4} - \frac{1073}{1024\sqrt{2}x^5} - \frac{103}{32x^7} - \dots$$

Proceeding as for  $Zb(x)$ , we obtain

$$Wb(x) = \frac{1}{2\sqrt{2}\pi x} e^{2\omega} \text{ where}$$

$$\omega = \frac{x}{\sqrt{2}} + \frac{1}{8\sqrt{2}x} + \frac{1}{16x^2} + \frac{23}{384\sqrt{2}x^3} - \frac{1}{128x^4} - \frac{1153}{5120\sqrt{2}x^5} - \frac{835}{1536x^6} \dots$$

§ 14. The differential equations of the 4th order (see § 11) are all unchanged by substitution of  $-x$ , or  $x$ , for  $x$ ; therefore the same coefficients furnish four independent solutions of each equation.

The ker, kei, &c., forms are of course obtained by substituting  $-x$  for

$x$  and  $\sqrt{\frac{\pi}{2}}$  for  $\sqrt{\frac{1}{2\pi}}$ . The expansions of the mixed functions are:

$$\left. \begin{aligned} Xr(x) &= \} \frac{1}{2x} \exp. \left( -\frac{13}{64x^4} + \dots \right) \left\{ \begin{array}{l} \cos \\ \sin \end{array} \right\} \left( x\sqrt{2} - \frac{1}{4\sqrt{2}x} - \frac{25}{192\sqrt{2}x^3} \right. \\ Xu(x) &= \} \left. + \frac{1073}{2560\sqrt{2}x^5} + \dots \right\} \end{aligned}$$

$$\left. \begin{aligned} Vr(x) &= \} -\frac{1}{2x} \exp. \left( +\frac{27}{64x^4} - \dots \right) \left\{ \begin{array}{l} \cos \\ \sin \end{array} \right\} \left( x\sqrt{2} + \frac{3}{4\sqrt{2}x} + \frac{21}{64\sqrt{2}x^3} \right. \\ Vu(x) &= \} \left. -\frac{1899}{2560\sqrt{2}x^5} - \dots \right\} \end{aligned}$$

$$\left. \begin{aligned} Zr(x) &= - \} \frac{1}{2\sqrt{2}x} \exp. \left( +\frac{3}{8x^2} - \frac{9}{64x^4} - \frac{387}{256x^6} + \dots \right) \left\{ \begin{array}{l} \sin \\ \cos \end{array} \right\} \left( x\sqrt{2} \right. \\ Zu(x) &= + \} \left. + \frac{3}{4\sqrt{2}x} - \frac{27}{64\sqrt{2}x^3} - \frac{1179}{2560\sqrt{2}x^5} + \dots \right\} \end{aligned}$$

$$\left. \begin{aligned} Wr(x) &+ \} \frac{2}{2\sqrt{2}x} \exp. \left( -\frac{1}{8x^2} - \frac{1}{64x^4} + \frac{835}{768x^6} + \dots \right) \left\{ \begin{array}{l} \sin \\ \cos \end{array} \right\} \left( x\sqrt{2} \right. \\ Wu(x) &- \} \left. -\frac{1}{4\sqrt{2}x} + \frac{23}{192\sqrt{2}x^3} + \frac{1153}{2560\sqrt{2}x^5} - \dots \right\} \end{aligned}$$

§ 15. The expansions of the ratios, similar to those given above for  $\frac{Zb(x)}{Xb(x)}$  and  $\frac{Wb(x)}{Xb(x)}$ , may be noted here.

From  $e^{2x} = 2\pi x Vb(x)$ ; taking logs and differentiating, and noticing that  $Vb'(x) = 2\left(Wb(x) - \frac{1}{x}Vb(x)\right)$

$$\frac{Wb(x)}{Vb(x)} = \eta' + \frac{1}{2x} = \frac{1}{\sqrt{2}} + \frac{1}{2x} + \frac{3}{8\sqrt{2}x^2} - \frac{63}{128\sqrt{2}x^4} - \frac{27}{32x^5} - \frac{1899}{1024\sqrt{2}x^6} + \dots$$

From  $e^{2x} = 2\sqrt{2}\pi x Zb(x)$ , differentiating as before and noticing that  $Zb'(x) = Vb(x) - \frac{1}{x}Zb(x)$

$$\frac{Vb(x)}{Zb(x)} = 2\eta' = 2 \left\{ \frac{1}{\sqrt{2}} + \frac{3}{8\sqrt{2}x^2} + \frac{3}{8x^3} + \frac{81}{128\sqrt{2}x^4} + \frac{9}{32x^5} - \frac{1179}{1024\sqrt{2}x^6} - \frac{1161}{256x^7} - \dots \right.$$

From  $e^{2x} = 2\sqrt{2}\pi x Wb(x)$ , noticing that  $Wb'(x) = Xb(x) - \frac{1}{x}Wb(x)$ .

$$\frac{Xb(x)}{Wb(x)} = 2\omega' = 2 \left\{ \frac{1}{\sqrt{2}} - \frac{1}{8\sqrt{2}x^2} - \frac{1}{8x^3} - \frac{23}{128\sqrt{2}x^4} + \frac{1}{32x^5} + \frac{1153}{1024\sqrt{2}x^6} + \frac{835}{256x^7} + \dots \right.$$

From  $\phi = \text{arc tan } \frac{\text{bei}'x}{\text{ber}'x}$ , differentiating

$$\frac{Zb(x)}{Vb(x)} = \phi' = \frac{1}{\sqrt{2}} - \frac{3}{8\sqrt{2}x^2} - \frac{3}{8x^3} - \frac{63}{128\sqrt{2}x^4} + \frac{1899}{1024\sqrt{2}x^6} + \frac{81}{16x^7} + \dots *$$

From  $\frac{Vb(x)}{Xb(x)} = \left\{ \frac{Zb(x)}{Xb(x)} \right\}^2 + \left\{ \frac{Wb(x)}{Xb(x)} \right\}^2$  (see §16).

$$\frac{Vb(x)}{Xb(x)} = 1 - \frac{1}{\sqrt{2}x} + \frac{1}{4x^2} + \frac{3}{8\sqrt{2}x^3} + \frac{13}{32x^4} + \frac{83}{128\sqrt{2}x^5} - \frac{25}{64x^6} - \frac{7719}{1024\sqrt{2}x^7} - \dots$$

The ker, kei, &c., functions yield similar series with the sign of  $x$  changed.

\* It will be seen that we may also obtain the coefficients in the series  $\zeta$  and  $\omega$  as follows:  $\zeta = \frac{1}{2} \int \frac{Vb(x)}{Zb(x)} dx = \frac{1}{2} \int \frac{dx}{\phi'}$ , &c.;  $\omega = \frac{1}{2} \int \frac{Xb(x)}{Wb(x)} dx = \frac{1}{2} \int \frac{dx}{\omega'}$ , &c.

§ 16. The following properties are useful in checking calculations :

$$Vb(x).Xb(x) = Zb^2(x) + Wb^2(x) \dots = I_0(x\sqrt{i}) I'_0(x\sqrt{i}) J_0(x\sqrt{i}) J'_0(x\sqrt{i})$$

$$Vk(x).Xk(x) = Zk^2(x) + Wk^2(x) \quad \&c.$$

$$Vr(x).Xr(x) = Zr^2(x) + Wr^2(x) - \frac{1}{4x^2}$$

$$Vu(x).Xu(x) = Zu^2(x) + Wu^2(x) - \frac{1}{4x^2}$$

$$Xb(x) Xk(x) = Xr^2(x) + Xu^2(x) = I_0(x\sqrt{i}). J_0(x\sqrt{i}). K_0(x\sqrt{i}). (G_0(x\sqrt{i}))$$

$$Vb(x) Vk(x) = Vr^2(x) + Vu^2(x) \quad \&c.$$

$$Zb(x) Zk(x) = Zr^2(x) + Zu^2(x) - \frac{1}{4x^2}$$

$$Wb(x) Wk(x) = Wr^2(x) + Wu^2(x) - \frac{1}{4x^2}$$

Table of the functions when  $x=6$ , to illustrate the foregoing expansions and properties :

$Xb(6)$	+ 132.2682	$Xk(6)$	+ .0000525042	$Xr(6)$	- .0471463	$Xu(6)$	+ .0687158
$Vb(6)$	+ 117.7264	$Vk(6)$	+ .0000590055	$Vr(6)$	+ .0550093	$Vu(6)$	- .0626138
$Zb(6)$	+ 82.1505	$Zk(6)$	- .0000413761	$Zr(6)$	- .0448258	$Zu(6)$	- .0391922
$Wb(6)$	+ 93.9296	$Wk(6)$	- .0000372298	$Wr(6)$	+ .0483902	$Wu(6)$	+ .0332545

TABLE V.

(Note.—Tables of ber  $x$ , &c., and of ker  $x$ , &c., will be found in the British Association Reports of 1912 and 1915 respectively.)

$x$	$Xb(x)$	$Vb(x)$	$Zb(x)$	$Wb(x)$
0·0	1	0	0	0
·2	1·00005	·0100001	·0005000	·100002
·4	1·00080	·0400053	·0040003	·200053
·6	1·00405	·090061	·0135046	·300405
·8	1·01281	·160341	·0320341	·401707
1·0	1·03129	·251303	·0626628	·505212
1·2	1·06498	·363892	·108584	·612981
1·4	1·12065	·499824	·173218	·728096
1·6	1·20655	·661920	·260379	·854893
1·8	1·33255	·854529	·374501	·999223
2·0	1·51046	1·08403	·520949	1·168755
2·2	1·75450	1·35944	·706429	1·37335
2·4	2·08193	1·69315	·93951	1·62553
2·6	2·51392	2·10186	1·23131	1·94108
2·8	3·07672	2·60770	1·59633	2·33986
3·0	3·80325	3·23967	2·05354	2·84679
3·2	4·73513	4·03545	2·62780	3·49329
3·4	5·92538	5·04380	3·35153	4·31898
3·6	7·44187	6·32750	4·26701	5·37411
3·8	9·37181	7·96737	5·42919	6·72254
4·0	11·82753	10·06727	6·90940	8·44578
4·2	14·9539	12·7608	8·8000	10·6482
4·4	18·9381	16·2199	11·2208	13·4636
4·6	24·0217	20·6660	14·3263	17·0643
4·8	30·5169	26·3848	18·3169	21·6720
5·0	38·8274	33·7452	23·4516	27·5728
5·2	49·4749	43·2237	30·0653	35·1364
5·4	63·1341	55·4372	38·5921	44·8401
5·6	80·6778	71·1843	49·5937	57·3015
5·8	103·235	91·500	63·7984	73·320
6·0	132·268	117·726	82·150	93·930
6·2	169·670	151·605	105·875	120·471
6·4	217·895	195·396	136·563	154·681
6·6	280·122	252·035	176·279	198·812
6·8	360·476	325·338	227·708	255·784
7·0	464·311	420·263	294·339	329·389
7·2	598·573	543·256	380·710	424·546
7·4	772·290	702·711	492·726	547·648
7·6	997·186	909·539	638·064	706·998
7·8	1288·51	1177·95	826·74	913·39
8·0	1666·08	1526·44	1071·78	1180·87
8·2	2155·69	1979·12	1390·15	1527·69
8·4	2790·90	2567·39	1803·99	1977·61
8·6	3615·41	3332·19	2342·13	2561·58
8·8	4686·14	4326·90	3042·17	3319·88
9·0	6077·21	5621·11	3953·18	4305·00
9·2	7885·26	7305·63	5139·16	5585·32
9·4	10236·23	9498·98	6683·64	7250·02
9·6	13294·4	12355·8	8695·7	9415·3
9·8	17273·9	16078·1	11317·6	12232·9
10·0	22454·3	20929·6	14735·4	15900·5

TABLE VI.

$x$	$Xk(x)$	$Vk(x)$	$-Zk(x)$	$-Wk(x)$
0	$\infty$	$\infty$	$\infty$	$\infty$
.2	3.578536	24.28511	8.701176	3.345845
.4	1.624504	5.62803	2.717202	1.326491
.6	.886757	2.24272	1.231493	.687150
.8	.525874	1.103742	.650496	.396591
1.0	.327220	.606639	.373568	.242799
1.2	.210158	.356545	.226108	.154291
1.4	.138048	.219118	.141870	.100606
1.6	.0922234	.1389881	.0913721	.0668513
1.8	.0624249	.0902563	.0600250	.0450694
2.0	.0427017	.0596793	.0400477	.0307342
2.2	.0294633	.0398631	.0269829	.0211286
2.4	.0204761	.0271615	.0184628	.0146726
2.6	.0143175	.0186069	.0127076	.0102431
2.8	.0100639	.0128489	.00880954	.00719042
3.0	.00710636	.00893315	.00614495	.00507167
3.2	.00503806	.00624709	.00430923	.00359218
3.4	.00358437	.00439086	.00303602	.00255363
3.6	.00255816	.00309989	.00214779	.00182127
3.8	.00183091	.00219708	.00152498	.00130273
4.0	.00131374	.00156261	.00108629	.000934262
4.2	.000944827	.001114834	.000776066	.000671600
4.4	.000680933	.000797598	.000555901	.000483822
4.6	.000491686	.000572080	.000399151	.000349232
4.8	.000355660	.000411271	.000287226	.000252534
5.0	.000257682	.000296286	.000207099	.000182913
5.2	.000186975	.000213858	.000149600	.000132688
5.4	.000135858	.000154635	.000108247	.000096390
5.6	.0000988426	.0001119950	.0000784476	.0000701132
5.8	.0000719989	.0000812348	.0000569341	.0000510620
6.0	.0000525042	.0000590055	.0000413761	.0000372298
6.2	.0000383282	.0000429148	.0000301073	.0000271735
6.4	.0000280072	.0000312498	.0000219332	.0000198533
6.6	.0000204844	.0000227814	.0000159960	.0000145187
6.8	.0000149953	.0000166254	.0000116779	.0000106269
7.0	.00001098614	.00001214503	.00000853371	.00000778478
7.2	.00000805511	.00000888036	.00000624176	.00000570725
7.4	.00000591042	.00000649898	.00000456930	.00000418727
7.6	.00000433977	.00000476016	.00000334768	.00000307426
7.8	.00000318862	.00000348930	.00000245455	.00000225860
8.0	.00000234430	.00000255965	.00000180100(5)	.00000166041
8.2	.00000172457	.00000187900	.00000132238(5)	.00000122138
8.4	.00000126940	.00000138028	.00000097160	.00000089896
8.6	.000000934870	.000001014568	.000000714306	.000000662009
8.8	.000000688858	.000000746207	.000000525462	.000000487771
9.0	.000000507837	.000000549146	.000000386762	.000000359572
9.2	.000000374563	.000000404349	.000000284827	.000000265194
9.4	.000000276390	.000000297888	.000000209866	.000000195677
9.6	.000000204038	.000000219567	.000000154710	.000000144446
9.8	.000000150688	.000000161917	.000000114104	.000000106674
10.0	.0000001113328	.0000001194581	.0000000841936	.0000000788102

TABLE VII. (See § 8, p. 110.)

$x$	$Vr(x)$	$Vu(x)$	$x$	$Vr(x)$	$Vu(x)$
0	0	-.500000	5.2	-.0371624	-.0886720
0.2	+.0247540	-.492179	5.4	-.0108757	-.0919472
0.4	+.0713026	-.469113	5.6	+.0143658	-.0881244
0.6	+.124040	-.431967	5.8	+.0368098	-.0779618
0.8	+.174894	-.382606	6.0	+.0550093	-.0626138
1.0	+.218643	-.323490	6.2	+.0679052	-.0435313
1.2	+.251844	-.257524	6.4	+.0748787	-.0223443
1.4	+.272422	-.187900	6.6	+.0757705	-.0007394
1.6	+.279458	-.117907	6.8	+.0708683	+.0196616
1.8	+.273040	-.050751	7.0	+.0608633	+.0374134
2.0	+.254128	+.010625(5)	7.2	+.0467809	+.0513408
2.2	+.223987	+.063413	7.4	+.0298904	+.0606091
2.4	+.186138	+.106494	7.6	+.0116026	+.0647682
2.6	+.141961	+.137681	7.8	-.0066396	+.0637662
2.8	+.094732	+.156626	8.0	-.0234668	+.0579349
3.0	+.047328	+.163403	8.2	-.0376797	+.0479480
3.2	+.002473	+.158757	8.4	-.0483291	+.0347564
3.4	-.037420	+.144036	8.6	-.0547744	+.0195065
3.6	-.070384	+.121081	8.8	-.0567175	+.0034470
3.8	-.094991	+.092096	9.0	-.0542104	-.0121671
4.0	-.1104176	+.0594913	9.2	-.0476367	-.0261681
4.2	-.1164649	+.0257313	9.4	-.0376694	-.0375586
4.4	-.1135359	-.0068231	9.6	-.0252095	-.0455787
4.6	-.1025796	-.0360562	9.8	-.0113098	-.0497534
4.8	-.0850008	-.0602179	10.0	+.0029099	-.0499173
5.0	-.0625442	-.0780156			

TABLE VIII.

$x$	$Vb(x)/Xb(x)$	$Zb(x)/Xb(x)$	$Wb(x)/Xb(x)$	$Zb(x)/Vb(x)$	$Wb(x)/Vb(x)$
0	0	0	0	0	$\infty$
.2	.010000	.0005000	.099997	.050000	10.00008
.4	.039973	.0039971	.199893	.099993	5.00067
.6	.089697	.0134501	.299193	.149949	3.33557
.8	.158314	.0316291	.396628	.199787	2.50532
1.0	.243678	.0607616	.489883	.249352	2.01037
1.2	.34169	.101959	.57558	.298395	1.68451
1.4	.44601	.154569	.64971	.34656	1.45671
1.6	.54861	.215804	.70854	.39337	1.29154
1.8	.64128	.281043	.74986	.43826	1.16933
2.0	.71768	.344896	.77378	.48057	1.07816
2.2	.77483	.40264	.78276	.51965	1.01023
2.4	.81326	.45127	.78078	.55489	.96006
2.6	.83609	.48980	.77213	.58582	.92351
2.8	.84756	.51884	.76050	.61216	.89729
3.0	.85181	.53994	.74852	.63388	.87873
3.2	.85224	.55496	.73774	.65118	.86565
3.4	.85122	.56562	.72890	.66449	.85630
3.6	.85026	.57338	.72215	.67436	.84933
3.8	.85014	.57931	.71731	.68143	.84376
4.0	.85117	.58418	.71408	.68632	.83893
4.2	.85334	.58848	.71206	.68962	.83444
4.4	.85647	.59250	.71093	.69179	.83007

TABLE VIII.—continued.

$x$	$Vb(x)/Xb(x)$	$Zb(x)/Xb(x)$	$Wb(x)/Xb(x)$	$Zb(x)/Vb(x)$	$Wb(x)/Vb(x)$
4.6	.86031	.59639	.71037	.69323	.82572
4.8	.86460	.60022	.71016	.69422	.82138
5.0	.86911	.60400	.71014	.69496	.81709
5.2	.87365	.60769	.71019	.69557	.81290
5.4	.87809	.61127	.71024	.69614	.80884
5.6	.88233	.61471	.71025	.69669	.80497
5.8	.88633	.61799	.71022	.69725	.80131
6.0	.89006	.62109	.71014	.69781	.79786
6.2	.89353	.62401	.71003	.69836	.79464
6.4	.89674	.62674	.70989	.69890	.79163
6.6	.89973	.62929	.70973	.69942	.78883
6.8	.90252	.63169	.70957	.69991	.78621
7.0	.90513	.63393	.70941	.70037	.78377
7.2	.90759	.63603	.70926	.70079	.78148
7.4	.90990	.63801	.70912	.70118	.77934
7.6	.91210	.63987	.70899	.70153	.77732
7.8	.91419	.64163	.70888	.70185	.77541
8.0	.91619	.64329	.70877	.70214	.77361
8.2	.91809	.64488	.70868	.70241	.77190
8.4	.91992	.64638	.70859	.70265	.77028
8.6	.92166	.64782	.70852	.70288	.76874
8.8	.92334	.64919	.70845	.70308	.76727
9.0	.92495	.65049	.70838	.70327	.76586
9.2	.92649	.65174	.70832	.70345	.76452
9.4	.92798	.65294	.70827	.70362	.76324
9.6	.92940	.65409	.70822	.70377	.76202
9.8	.93078	.65519	.70817	.70391	.76084
10.0	.93210	.65624	.70813	.70405	.75972
$\infty$	1.00000	.70711	.70711	.70711	.70711

*Note on the Graphs of these Ratio Functions.*

$Zb/Xb$  and  $Zb/Vb$  increase, and  $Wb/Vb$  decreases, with the argument.  $Vb/Xb$  increases up to a maximum value .85295 when  $x=3.1286$ , decreasing then to a minimum value .85006 when  $x=3.7233$ ; thereafter it increases towards the asymptotic value 1.

$Wb/Xb$  increases up to a maximum value .78812 when  $x=2.2534$ , then descends to a minimum value .71013 when  $x=4.9360$ ; it then rises slightly to a maximum .71025 when  $x=5.5727$ , thereafter it decreases towards the asymptotic value  $\frac{1}{2}\sqrt{2}=.70711$ .

There is an error in Prof. Webster's Table of  $bei'x$  which necessitated the recalculation of part of the Table. The error becomes considerable as the argument increases, and the corrected figures used in calculating the foregoing Tables are given below.

TABLE IX.

$x$	$\text{bei}'x$	$x$	$\text{bei}'x$
6·5	-14·129423	8·6	+12·832116
6·6	-14·670413	8·7	+17·883387
6·7	-15·146266	8·8	+23·465444
6·8	-15·543406	8·9	+29·598302
6·9	-15·847109	9·0	+36·299384
7·0	-16·041489	9·1	+43·582976
7·1	-16·109484	9·2	+51·459634
7·2	-16·032856	9·3	+59·935547
7·3	-15·792207	9·4	+69·011850
7·4	-15·367001	9·5	+78·683888
7·5	-14·735602	9·6	+88·940434
7·6	-13·875334	9·7	+99·762855
7·7	-12·762551	9·8	+111·124240
7·8	-11·372739	9·9	+122·988479
7·9	-9·680623	10·0	+135·309302
8·0	-7·660318	10·1	+148·029283
8·1	-5·285490	10·2	+161·078815
8·2	-2·529555	10·3	+174·375051
8·3	+0·634098	10·4	+187·820832
8·4	+4·231841	10·5	+201·303603
8·5	+8·289519		

The following simultaneous equation occurs in practice (see Russell's 'Alternating Currents,' 2nd ed., vol. i. p. 222):—

$$\begin{aligned} A \text{ber } x + B \text{bei } x + C \text{ker } x + D \text{kei } x &= 1 \\ A \text{bei } x - B \text{ber } x + C \text{kei } x - D \text{ker } x &= 0 \\ A \text{ber}'x + B \text{bei}'x + C \text{ker}'x + D \text{kei}'x &= 0 \\ A \text{bei}'x - B \text{ber}'x + C \text{kei}'x - D \text{ker}'x &= 0 \end{aligned}$$

From the relations (§ 7)

$$\begin{aligned} \text{ber } x \text{ker}'x + \text{bei}'x \text{kei } x - \text{ber}'x \text{ker } x - \text{bei } x \text{kei}'x &= -1/x \\ \text{ber } x \text{kei}'x + \text{bei } x \text{ker}'x - \text{ber}'x \text{kei } x - \text{bei}'x \text{ker } x &= 0 \end{aligned}$$

we may write the solution of the equation by inspection:—

$$A = -x\text{ker}'x \quad B = +x\text{kei}'x \quad C = +x\text{ber}'x \quad D = -x\text{bei}'x.$$



## PART V. (Prof. G. N. Watson.)

TABLE X.

*Table of the Logarithmic Gamma Function.*

$x$	$10 + \log_e \Gamma(1+x)$	$x$	$10 + \log_e \Gamma(1+x)$	$x$	$10 + \log_e \Gamma(1+x)$
.005	9.9971344334	.270	9.8974168067	.535	9.8810616420
.010	9.9943096921	.275	9.8964125776	.540	9.8814165100
.015	9.9915254813	.280	9.8954374731	.545	9.8817939466
.020	9.9887815107	.285	9.8944913366	.550	9.8821938554
.025	9.9860774933	.290	9.8935740128	.555	9.8826161405
.030	9.9834131461	.295	9.8926853481	.560	9.8830607072
.035	9.9807881899	.300	9.8918251905	.565	9.8835274612
.040	9.9782023489	.305	9.8909933893	.570	9.8840163092
.045	9.9756553510	.310	9.8901897955	.575	9.8845271585
.050	9.9731469275	.315	9.8894142616	.580	9.8850599172
.055	9.9706768132	.320	9.8886666413	.585	9.8856144942
.060	9.9682447463	.325	9.8879467900	.590	9.8861907991
.065	9.9658504682	.330	9.8872545645	.595	9.8867887421
.070	9.9634937237	.335	9.8865898228	.600	9.8874082343
.075	9.9611742605	.340	9.8859524244	.605	9.8880491873
.080	9.9588918298	.345	9.8853422303	.610	9.8887115136
.085	9.9566461857	.350	9.8847591026	.615	9.8893951263
.090	9.9544370852	.355	9.8842029049	.620	9.8900999390
.095	9.9522642886	.360	9.8836735020	.625	9.8908258662
.100	9.9501275587	.365	9.8831707599	.630	9.8915728231
.105	9.9480266616	.370	9.8826945461	.635	9.8923407254
.110	9.9459613659	.375	9.8822447293	.640	9.8931294895
.115	9.9439314431	.380	9.8818211791	.645	9.8939390324
.120	9.9419366675	.385	9.8814237669	.650	9.8947692718
.125	9.9399768159	.390	9.8810523647	.655	9.8956201261
.130	9.9380516678	.395	9.8807068462	.660	9.8964915140
.135	9.9361610054	.400	9.8803870858	.665	9.8973833553
.140	9.9343046133	.405	9.8800929595	.670	9.8982955699
.145	9.9324822788	.410	9.8798243441	.675	9.8992280788
.150	9.9306937913	.415	9.8795811177	.680	9.9001808031
.155	9.9289389431	.420	9.8793631594	.685	9.9011536649
.160	9.9272175284	.425	9.8791703495	.690	9.9021465865
.165	9.9255293442	.430	9.8790025693	.695	9.9031594912
.170	9.9238741894	.435	9.8788597013	.700	9.9041923026
.175	9.9222518655	.440	9.8787416287	.705	9.9052449448
.180	9.9206621760	.445	9.8786482362	.710	9.9063173427
.185	9.9191049267	.450	9.8785794093	.715	9.9074094215
.190	9.9175799255	.455	9.8785350343	.720	9.9085211071
.195	9.9160869826	.460	9.8785149990	.725	9.9096523259
.200	9.9146259100	.465	9.8785191917	.730	9.9108030049
.205	9.9131965220	.470	9.8785475020	.735	9.9119730714
.210	9.9117986349	.475	9.8785998202	.740	9.9131624535
.215	9.9104320669	.480	9.8786760379	.745	9.9143710797
.220	9.9090966382	.485	9.8787760472	.750	9.9155988790
.225	9.9077921709	.490	9.8788997415	.755	9.9168457808
.230	9.9065184892	.495	9.8790470148	.760	9.9181117153
.235	9.9052754189	.500	9.8792177623	.765	9.9193966129
.240	9.9040627878	.505	9.8794118800	.770	9.9207004045
.245	9.9028804256	.510	9.8796292647	.775	9.9220230218
.250	9.9017281636	.515	9.8798698140	.780	9.9233643966
.255	9.9006058349	.520	9.8801334265	.785	9.9247244614
.260	9.8995132746	.525	9.8804200017	.790	9.9261031491
.265	9.8984503191	.530	9.8807294399	.795	9.9275003930

Table of the Logarithmic Gamma Function—continued.

$x$	$10 + \log_e \Gamma(1+x)$	$x$	$10 + \log_e \Gamma(1+x)$	$x$	$10 + \log_e \Gamma(1+x)$
.800	9.9289161271	.870	9.9506418694	.940	9.9758086419
.805	9.9303502855	.875	9.9523273146	.945	9.9777337222
.810	9.9318028031	.880	9.9540302503	.950	9.9796755009
.815	9.9332736150	.885	9.9557506176	.955	9.9816339239
.820	9.9347626569	.890	9.9574883577	.960	9.9836089379
.825	9.9362698647	.895	9.9592434125	.965	9.9856004894
.830	9.9377951751	.900	9.9610157241	.970	9.9876085256
.835	9.9393385250	.905	9.9628052350	.975	9.9896329940
.840	9.9408998517	.910	9.9646118882	.980	9.9916738422
.845	9.9424790929	.915	9.9664356268	.985	9.9937310184
.850	9.9440761870	.920	9.9682763946	.990	9.9958044709
.855	9.9456910724	.925	9.9701341354	.995	9.9978941484
.860	9.9473236883	.930	9.9720087938	1.000	10.0000000000
.865	9.9489739740	.935	9.9739003142		

TABLE XI.

Table of the Integral of the Logarithmic Gamma Function.

$x$	$10 + \int_0^x \log_{10} \Gamma(1+t) dt$	$x$	$10 + \int_0^x \log_{10} \Gamma(1+t) dt$	$x$	$10 + \int_0^x \log_{10} \Gamma(1+t) dt$
.01	9.9999875846	.34	9.9896969629	.68	9.9725834399
.02	9.9999508093	.35	9.9891990301	.69	9.9721541702
.03	9.9998903733	.36	9.9886961491	.70	9.9717336117
.04	9.9998069658	.37	9.9881887854	.71	9.9713221100
.05	9.9997012663	.38	9.9876773998	.72	9.9709200084
.06	9.9995739448	.39	9.9871624486	.73	9.9705276475
.07	9.9994256625	.40	9.9866443836	.74	9.9701453654
.08	9.9992570712	.41	9.9861236524	.75	9.9697734976
.09	9.9990688145	.42	9.9856006982	.76	9.9694123772
.10	9.9988615270	.43	9.9850759598	.77	9.9690623348
.11	9.9986358354	.44	9.9845498721	.78	9.9687236987
.12	9.9983923582	.45	9.9840228658	.79	9.9683967947
.13	9.9981317060	.46	9.9834953678	.80	9.9680819463
.14	9.9978544815	.47	9.9829678008	.81	9.9677794747
.15	9.9975612803	.48	9.9824405838	.82	9.9674896989
.16	9.9972526903	.49	9.9819141321	.83	9.9672129355
.17	9.9969292922	.50	9.9813888569	.84	9.9669494991
.18	9.9965916600	.51	9.9808651662	.85	9.9666997019
.19	9.9962403605	.52	9.9803434641	.86	9.9664638540
.20	9.9958759540	.53	9.9798241513	.87	9.9662422636
.21	9.9954989940	.54	9.9793076250	.88	9.9660352364
.22	9.9951100280	.55	9.9787942789	.89	9.9658430763
.23	9.9947095968	.56	9.9782845034	.90	9.9656660852
.24	9.9942982352	.57	9.9777786856	.91	9.9655045628
.25	9.9938764720	.58	9.97727272093	.92	9.9653588069
.26	9.9934448302	.59	9.9767804551	.93	9.9652291134
.27	9.9930038268	.60	9.9762888003	.94	9.9651157760
.28	9.9925539734	.61	9.9758026197	.95	9.9650190869
.29	9.9920957760	.62	9.9753222842	.96	9.9649393361
.30	9.9916297350	.63	9.9748481622	.97	9.9648768117
.31	9.9911563457	.64	9.9743806190	.98	9.9648318002
.32	9.9906760982	.65	9.9739200170	.99	9.9648045862
.33	9.9901894773	.66	9.9734667158	1.00	9.9647954523
		.67	9.9730210722		

TABLE XII.

*Table of the Logarithmic Derivate of the Gamma Function.*

$x$	$\psi(x) = \frac{d}{dx} \log_e \Gamma(x)$	$x$	$\psi(x) = \frac{d}{dx} \log_e \Gamma(x)$	$x$	$\psi(x) = \frac{d}{dx} \log_e \Gamma(x)$
1	1.4227843350985	35	3.5409943255439	69	4.2268426248273
2	0.4227843350985	36	3.5695657541153	70	4.2413353784505
3	0.9227843350985	37	3.5973435318931	71	4.2556210927362
4	1.2561176684318	38	3.6243705589201	72	4.2697055997785
5	1.5061176684318	39	3.6506863483938	73	4.2835944886674
6	1.7061176684318	40	3.6763273740348	74	4.2972931188044
7	1.8727843350985	41	3.7013273740348	75	4.3108066323179
8	2.0156414779556	42	3.7257176179372	76	4.3241399656512
9	2.1406414779556	43	3.7495271417467	77	4.3372978603880
10	2.2517525890667	44	3.7727829557002	78	4.3502848733750
11	2.3517525890667	45	3.7955102284275	79	4.3631053861955
12	2.4426616799758	46	3.8177324506497	80	4.3757636140436
13	2.5259950133091	47	3.8394715810845	81	4.3882636140436
14	2.6029180902322	48	3.8607481768291	82	4.4006092930559
15	2.6743466616608	49	3.8815815101624	83	4.4128044150071
16	2.7410133283275	50	3.9019896734277	84	4.4248526077782
17	2.8035133283275	51	3.9219896734277	85	4.4367573696830
18	2.8623368577393	52	3.9415975165649	86	4.4485220755654
19	2.9178924132949	53	3.9608282857957	87	4.4601499825421
20	2.9705239922423	54	3.9796962103240	88	4.4716442354153
21	3.0205239922423	55	3.9982147288425	89	4.4830078717789
22	3.0681430398613	56	4.0163965470243	90	4.4942438268351
23	3.1135975853158	57	4.0342536898814	91	4.5053549379462
24	3.1570758461854	58	4.0517975495305	92	4.5163439489352
25	3.1987425128521	59	4.0690389288408	93	4.5272135141526
26	3.2387425128521	60	4.0859880813832	94	4.5379662023246
27	3.2772040513136	61	4.1026547480499	95	4.5486045001969
28	3.3142410883506	62	4.1190481906729	96	4.5591308159864
29	3.3499553740649	63	4.1351772229310	97	4.5695474826531
30	3.3844381326856	64	4.1510502388040	98	4.5798567610036
31	3.4177714660189	65	4.1666752388040	99	4.5900608426362
32	3.4500295305350	66	4.1820598541886	100	4.6001618527372
33	3.4812795305350	67	4.1972113693401	101	4.6101618527372
34	3.5115825608380	68	4.2121367424744		

TABLE XIII.

Table of the Logarithmic Derivate of the Gamma Function,  $\psi(x)$ , for halves of odd integers.

$x$	$\psi(x) = \frac{d}{dx} \log_e \Gamma(x)$	$x$	$\psi(x) = \frac{d}{dx} \log_e \Gamma(x)$	$x$	$\psi(x) = \frac{d}{dx} \log_e \Gamma(x)$
$1\frac{1}{2}$	0.0364899739786	$34\frac{1}{2}$	3.5263965629911	$68\frac{1}{2}$	4.2195167157917
$2\frac{1}{2}$	0.7031566406453	$35\frac{1}{2}$	3.5553820702375	$69\frac{1}{2}$	4.2341152559377
$3\frac{1}{2}$	1.1031566406453	$36\frac{1}{2}$	3.5835510843220	$70\frac{1}{2}$	4.2485037451463
$4\frac{1}{2}$	1.3888709263596	$37\frac{1}{2}$	3.6109483445960	$71\frac{1}{2}$	4.2626881423094
$5\frac{1}{2}$	1.6110931485818	$38\frac{1}{2}$	3.6376150112627	$72\frac{1}{2}$	4.2766741562954
$6\frac{1}{2}$	1.7929113304000	$39\frac{1}{2}$	3.6635890372367	$73\frac{1}{2}$	4.2904672597437
$7\frac{1}{2}$	1.9467574842461	$40\frac{1}{2}$	3.6889054929329	$74\frac{1}{2}$	4.3040727019205
$8\frac{1}{2}$	2.0800908175794	$41\frac{1}{2}$	3.7135968509575	$75\frac{1}{2}$	4.3174955207124
$9\frac{1}{2}$	2.1977378764029	$42\frac{1}{2}$	3.7376932364997	$76\frac{1}{2}$	4.3307405538250
$10\frac{1}{2}$	2.3030010342976	$43\frac{1}{2}$	3.7612226482644	$77\frac{1}{2}$	4.3438124492498
$11\frac{1}{2}$	2.3982391295357	$44\frac{1}{2}$	3.7842111540115	$78\frac{1}{2}$	4.3567156750563
$12\frac{1}{2}$	2.4851956512748	$45\frac{1}{2}$	3.8066830641239	$79\frac{1}{2}$	4.3694545285595
$13\frac{1}{2}$	2.5651956512748	$46\frac{1}{2}$	3.8286610861019	$80\frac{1}{2}$	4.3820331449117
$14\frac{1}{2}$	2.6392697253489	$47\frac{1}{2}$	3.8501664624460	$81\frac{1}{2}$	4.3944555051601
$15\frac{1}{2}$	2.7082352425903	$48\frac{1}{2}$	3.8712190940249	$82\frac{1}{2}$	4.4067254438104
$16\frac{1}{2}$	2.7727513716226	$49\frac{1}{2}$	3.8918376507259	$83\frac{1}{2}$	4.4188466559316
$17\frac{1}{2}$	2.8333574322287	$50\frac{1}{2}$	3.9120396709279	$84\frac{1}{2}$	4.4308227038358
$18\frac{1}{2}$	2.8905002893715	$51\frac{1}{2}$	3.9318416511259	$85\frac{1}{2}$	4.4426570233624
$19\frac{1}{2}$	2.9445543434255	$52\frac{1}{2}$	3.9512591268541	$86\frac{1}{2}$	4.4543529297951
$20\frac{1}{2}$	2.9958363947075	$53\frac{1}{2}$	3.9703067459017	$87\frac{1}{2}$	4.4659136234367
$21\frac{1}{2}$	3.0446168825123	$54\frac{1}{2}$	3.9889983346867	$88\frac{1}{2}$	4.4773421948652
$22\frac{1}{2}$	3.0911285104193	$55\frac{1}{2}$	4.0073469585399	$89\frac{1}{2}$	4.4886416298934
$23\frac{1}{2}$	3.1355729548637	$56\frac{1}{2}$	4.0253649765579	$90\frac{1}{2}$	4.4998148142509
$24\frac{1}{2}$	3.1781261463531	$57\frac{1}{2}$	4.0430640916022	$91\frac{1}{2}$	4.5108645380078
$25\frac{1}{2}$	3.2189424728837	$58\frac{1}{2}$	4.0604553959500	$92\frac{1}{2}$	4.5217934997565
$26\frac{1}{2}$	3.2581581591582	$59\frac{1}{2}$	4.0775494130440	$93\frac{1}{2}$	4.5326043105673
$27\frac{1}{2}$	3.2958940082148	$60\frac{1}{2}$	4.0943561357330	$94\frac{1}{2}$	4.5432994977331
$28\frac{1}{2}$	3.3322576445784	$61\frac{1}{2}$	4.1108850613528	$95\frac{1}{2}$	4.5538815083151
$29\frac{1}{2}$	3.3673453638766	$62\frac{1}{2}$	4.1271452239544	$96\frac{1}{2}$	4.5643527125036
$30\frac{1}{2}$	3.4012436689613	$63\frac{1}{2}$	4.1431452239544	$97\frac{1}{2}$	4.5747154068041
$31\frac{1}{2}$	3.4340305542072	$64\frac{1}{2}$	4.1588932554505	$98\frac{1}{2}$	4.5849718170605
$32\frac{1}{2}$	3.4657765859532	$65\frac{1}{2}$	4.1743971314195	$99\frac{1}{2}$	4.5951241013245
$33\frac{1}{2}$	3.4965458167224	$66\frac{1}{2}$	4.1896643069920	$100\frac{1}{2}$	4.6051743525807
		$67\frac{1}{2}$	4.2047019009769		

*Radiotelegraphic Investigations.*—*Report of the Committee, consisting of Sir OLIVER LODGE (Chairman), Dr. W. H. ECCLES (Secretary), Mr. S. G. BROWN, Dr. C. CHREE, Sir F. W. DYSON, Professor A. S. EDDINGTON, Dr. ERSKINE-MURRAY, Professors J. A. FLEMING, G. W. O. HOWE, H. M. MACDONALD, and J. W. NICHOLSON, Sir H. NORMAN, Captain H. R. SANKEY, Professor A. SCHUSTER, Sir NAPIER SHAW, and Professor H. H. TURNER.*

THE observational work done for the Committee during the past year has been carried out at about twenty-five stations distributed in Australia, the United States of America, Canada, New Zealand, Ceylon, Trinidad, Dutch East Indies, Fiji, and the Gold Coast.

Of the four kinds of Forms issued by the Committee for the collection of statistics, the first, relating to the number and strength of the strays at 11 A.M. and 11 P.M. Greenwich mean time, has been in most regular use, and the stock is almost exhausted. No further edition of this Form will be issued during the war, and thus the collection of these statistics will come gradually to an end.

The difficulty of obtaining clerical assistance for the work of reducing the Forms has greatly impeded progress, but a certain amount of work has been accomplished and has yielded results of interest. So soon as the several sections of the work are rounded off the results will be published.

The reduction of Form I. is proceeding by the collation of records and reports of excessive atmospheric disturbance since August 1914 in North America and Australia, and by their examination in conjunction with meteorological data from the corresponding daily weather charts.

The reduction of Form II. is proceeding by the correlation of instances of exceptionally good or bad transmission with meteorological data, and by analysis of statistics from Cocos, Fiji, Lagos, Malta, and Sierra Leone.

Several important exceptional phenomena have been reported which will, after discussion, be published. These include reports of:—

Aurora, strays, and signals in Alaska and Hudson Bay.

Severe atmospheric disturbances in Malta.

Simultaneous strays on both sides of the Atlantic.

Effect of tropical storm in the Gulf of Mexico, September 30, 1915.

The Committee desire to express their cordial thanks for the favours extended to them by the Colonial Office, the Governments of Australia, Canada, and New Zealand, the War Department and the Navy Department of the United States of America, the Telegraphic Department of the Dutch East Indies, the Marconi Companies in the United States of America and Canada, the United Fruit Company of New York, the Eastern, the Eastern Extension and African Direct Telegraph Companies, and Professors T. Agius, R. S. Hayes, and A. Hoyt Taylor.

The assistance of those who have taken part in investigations other than those herein referred to will be duly acknowledged in a future report.

---

*The Influence of Weather Conditions upon the Amounts of Nitrogen Acids in the Rainfall and Atmosphere in Australia.*—Report of the Committee, consisting of Professor ORME MASSON (Chairman), Mr. V. G. ANDERSON (Secretary), and Messrs. D. AVERY and H. A. HUNT.

DURING the period March 15, 1916, to March 31, 1916, daily samples of rain-water collected at sixteen stations suitably distributed over the continent of Australia have been quantitatively examined for nitric and nitrous nitrogen. Altogether about 1,000 samples have been examined. The results when compared with the daily weather records and isobaric charts confirm the following conclusions drawn from the results of experiments previously conducted by V. G. Anderson at Canterbury, Victoria.<sup>1</sup>

- i. For a given type of weather *the concentration* of oxidised nitrogen in the rainfall varies inversely as the amount of rainfall.
- ii. *The total amount* of oxidised nitrogen per unit area found in the rainfall accompanying a storm depends upon the type of weather, and is practically independent of the amount of rainfall.

The work carried out during the past year has also shown that

- i. Antarctic storms at different stations carry down amounts of oxidised nitrogen which do not differ greatly from the amounts previously found at Canterbury.
- ii. Rain falling at northern stations during the prevalence of trade winds contains amounts of oxidised nitrogen which are almost equal to the amounts found in the rain accompanying Antarctic depressions (rear isobars) at southern stations. This is shown to be probably due to the anticyclonic origin of winds accompanying both types of rain.
- iii. Passage over land modifies anticyclonic air only to a slight extent; but, if during the passage it is subjected to the influences accompanying monsoonal disturbances, comparatively large amounts of oxidised nitrogen are found in the subsequent rainfall.
- iv. The highest total amounts of oxidised nitrogen are found at southern and inland stations in rain-water resulting from monsoonal storms following a 'heat wave.'
- v. Rains occurring during 'divided control' weather contain less oxidised nitrogen than tropical rains, but more than Antarctic rains.

<sup>1</sup> V. G. Anderson, *Report Brit. Assoc.* 1914, 338; *Quart. J. Roy. Met. Soc.* 1915, 41, 99.

- vi. The nitrogen-fixing powers of inland monsoonal depressions tend towards the gradual enrichment, in respect of oxidised nitrogen, of the soil in south-eastern Australia.

A number of determinations of the volume concentration of nitrogen peroxide in the atmosphere during the prevalence of anticyclonic weather has shown that at Canterbury, Victoria, in the rear circulation of anticyclones the air contains a greater proportion of nitrogen peroxide than the air of the front circulation.

On the assumption that the oxidised nitrogen of the rainfall is derived from the atmosphere, the amounts of nitrogen peroxide in the latter were compared with the amounts of oxidised nitrogen found in the rainfall at Canterbury for the corresponding weather types. It is shown that air containing 0.56 volume of nitrogen peroxide per 10<sup>9</sup> volumes in the rear of an anticyclone would require to be washed out to a height of about 4,000 feet above ground-level in order to give the amount of oxidised nitrogen usually found in the rainfall accompanying this weather condition; similarly in the case of the front of an anticyclone it is shown that the height would require to be about 3,100 feet. The above are in fair agreement with the average altitude of rain-clouds (base), which according to leading authorities is about 3,500 feet.

The Committee wishes to place on record an acknowledgment of its indebtedness to the following lady and gentlemen for their able assistance in collecting rain samples for this investigation:—

Miss J. Heinrichsen, Ballarat, Victoria.

S. Hebbard, Esq., Technical School, Sale, Victoria.

A. H. Bisdee, Esq., Wihareja, Steppes, Tasmania.

W. M. Lee Bryce, Esq., The Resident Magistrate, Thursday Island, Queensland.

F. Fairley, Esq., M.I.E.E., F.R.M.S., Woombye, Queensland.

Dr. H. Priestley, Australian Institute of Tropical Medicine, Townsville, Queensland.

R. Gordon Edgell, Esq., Bradwardine, Bathurst, N.S. Wales.

E. J. Cook, Esq., P.M. Hergott Springs, South Australia.

Simon Ockley, Esq., Comaum, Penola, South Australia.

W. A. Doran, Esq., P.M. Eucla, Western Australia.

G. R. Kirkby, Esq., P.M. Carnarvon, West Australia.

Major G. T. Wood, The Resident Magistrate, Broome, West Australia.

G. G. Lavater, Esq., A.R.V.I.A., Narrogin, West Australia.

Dr. Edwin Tyrie, Playford Hospital, Pine Creek, N.T.

J. McKay, Esq., P.M. Alice Springs, Northern Territory (Central).

With the approval of the Sectional Committee it is proposed to send the complete results of this investigation to the Royal Meteorological Society for publication.

The Committee does not seek reappointment.

*List of Apparatus.*

- 26 doz. 4 oz. stoppered bottles.
- 26 doz. double-lined cardboard boxes ( $2\frac{1}{4}$  in.  $\times$   $2\frac{1}{4}$  in.  $\times$  6 in.).
- 16 Rain-collecting gauges, complete with wooden stand, iron spikes, funnel, glass container, bottle-brush, and  $\frac{1}{2}$  oz. glass wool.
- \*1 sixteen-hole water bath of copper, complete with wooden stand and attachments.
- \*1 distilling apparatus, consisting of 1.5 litre Jena flask, Liebig's condenser, retort stands, clamps and bossheads.
- \*1 $\frac{1}{2}$  doz. glass basins ( $3\frac{1}{2}$  in. diam.).
- \*4 $\frac{3}{4}$  doz. Erlenmeyer flasks of Bohemian glass, 100 c.c. capacity.
- \*1 $\frac{3}{4}$  doz. watch glasses ( $1\frac{1}{2}$  in. diam.).
- \*2 Nessler tubes (70 c.c.) graduated.
- 5 wooden trays.

Much of the above apparatus is distributed amongst observers in different parts of Australia. The items marked with an asterisk, however, are in Melbourne, and would be suitable for carrying on work of a similar character.

---

*Dynamic Isomerism.—Report of the Committee, consisting of Professor H. E. ARMSTRONG (Chairman), Dr. T. M. LOWRY (Secretary), Professor SYDNEY YOUNG, Dr. C. H. DESCH, Sir J. J. DOBBIE, and Dr. M. O. FORSTER. (Drawn up by the Secretary.)*

IMPORTANT new evidence, which has been accumulated during the past year, indicates even more clearly than before that liquids containing a single optically-active component, of definite composition and of fixed molecular structure, may be expected in the majority of cases to exhibit the 'simple' type of rotary dispersion expressed by the formula  $\alpha(\lambda^2 - \lambda_0^2) = \text{const.}$  This formula has been tested in the case of forty-two compounds of the terpene series, for which data have recently been supplied by Professor Rupe, of Basel,<sup>1</sup> with the remarkable result that all but three have been found to conform closely to the 'simple' dispersion law. In view of the complicated character of the molecular structure in these compounds (which contain one, two, or three asymmetric carbon atoms, complex ring systems, and unsaturated linkages), it is clear that 'simple' rotary dispersion is not dependent on simple molecular structure, provided that the active substance is strictly homogeneous. 'Complex' or 'anomalous' rotary dispersion in an optically-active liquid (and especially in a liquid of apparently simple character) may therefore be regarded as an *a priori* reason for suspecting the existence of some anomaly of chemical composition—*e.g.*, polymerism, association or dissociation, or dynamic isomerism.

<sup>1</sup> *Ann.*, 1915, 409, 327.

---



*Absorption Spectra and Chemical Constitution of Organic Compounds.*—*Report of the Committee, consisting of Sir J. J. DOBBIE (Chairman), Professor E. C. C. BALY (Secretary), and Dr. A. W. STEWART.*

IN presenting the subjoined Report on Absorption Spectra and Chemical Constitution the Committee would draw attention to the fact that a Committee, composed of Sir W. N. Hartley, Sir James Dobbie, and Dr. A. Lauder, presented reports on this subject to the meetings of the British Association held in 1900, 1901, 1902, and 1903. Since 1903 the investigation of Absorption Spectra has been very considerably extended, and it was thought advisable to bring the subject up to date.

The list is believed to include every compound the Absorption Spectrum of which has properly been measured in the infra-red, visible, or ultra-violet regions of the spectrum. An addendum has been made, containing a list of those compounds the fluorescence or phosphorescence of which has been measured.

The journals are denoted by the usual abbreviated titles, with the exception of the Journal of the Chemical Society (London), which is referred to simply as Trans.

*List of Organic Compounds, the Absorption Spectra of which have been measured in the visible and ultra violet.*

A

Acenaphthene.	Baly and Tuck.	Trans., 93,	1902 (1908).
„	Purvis.	Trans., 101,	1315 (1912).
Acenaphthenequinone.	Baly and Stewart.	Trans., 89,	502 (1906).
Acenaphthylene.	Baly and Tuck.	Trans., 93,	1902 (1908).
Acetaldehyde.	Purvis and McClelland.	Trans., 101,	1910 (1912).
„	Bielecki and Henri.	Compt. rend., 155,	456 (1912).
„	„	Ber., 45,	2819 (1912).
„	„	Phys. Zeit., 14,	516 (1913).
„	„	Ber., 46,	3627 (1913).
„	Henri and Wurmser.	Compt. rend., 156,	230 (1913).
„	„	Jour. de Phys., 3,	305 (1913).
Acetaldehyde- <i>p</i> -bromophenylhydrazone.	Baly and Tuck.	Trans., 89,	982 (1906).
Acetaldehydephenylhydrazone.	Baly and Tuck.	Trans., 89,	982 (1906).
„	Stobbe and Nowak.	Ber., 46,	2887 (1913).
Acetaldehydephenylmethylhydrazone.	Baly and Tuck.	Trans., 89,	982 (1906).
Acetaldoxime.	Hartley and Dobbie.	Trans., 77,	318 (1900).
„	Bielecki and Henri.	Compt. rend., 156,	1860 (1913).
Acetamide.	Bielecki and Henri.	Compt. rend., 156,	1860 (1913).
Acetanilide.	Baly, Tuck, and Marsden.	Trans., 97,	571 (1910).
„	Crymble, Stewart, Wright, and Glendinning.	Trans., 99,	451 (1911).
Acetic acid.	Hartley and Huntington.	Phil. Trans., 170,	I. 257 (1879).
„	Bielecki and Henri.	Compt. rend., 155,	456, 1617 (1912).
„	„	Ber., 45,	2819 (1912).
„	„	Ber., 46,	1304, 2596, 3627 (1913).
„	„	Phys. Zeit., 14,	516 (1913).
„	„	Compt. rend., 156,	550 (1913).
„	„	Compt. rend., 157,	372 (1913).

- Acetic acid. Bielecki and Henri. *Compt. rend.*, **158**, 567 (1914).  
 " " " " *Ber.*, **47**, 1690 (1914).  
 " " Hantzsch. *Zeit. phys. Chem.*, **86**, 624 (1913).  
 " " Hantzsch and Scharf. *Ber.*, **46**, 3570 (1913).  
 " " Henri. *Ber.*, **46**, 3650 (1913).  
 " " and metallic salts. *Ley. Ber.*, **42**, 354 (1909).  
 " " " " Hantzsch and Scharf. *Ber.*, **46**, 3570 (1913).  
 " " " " Wright. *Trans.*, **103**, 528 (1913).  
 " " " " *Trans.*, **105**, 669 (1914).  
 Acetic anhydride. Hantzsch and Scharf. *Ber.*, **46**, 3570 (1913).  
 Acetoacetic acid, ethyl ester, *see* Ethyl acetoacetate.  
 Acetone. Stewart and Baly. *Trans.*, **89**, 489 (1906).  
 " Gelbke. *Phys. Zeit.*, **13**, 584 (1911).  
 " Bielecki and Henri. *Compt. rend.*, **155**, 456 (1912).  
 " " " *Ber.*, **45**, 2819 (1912).  
 " Hantzsch and Voigt. *Ber.*, **45**, 85 (1912).  
 " Henri and Wurmser. *Compt. rend.*, **155**, 503 (1912).  
 " Purvis and McClelland. *Trans.*, **101**, 1810 (1912).  
 " Bielecki and Henri. *Ber.*, **46**, 3627 (1913).  
 " " " *Compt. rend.*, **156**, 884, 1322 (1913).  
 " " " *Phys. Zeit.*, **14**, 516 (1913).  
 " Henri and Wurmser. *Compt. rend.*, **156**, 230 (1913).  
 " " " *Jour. de Phys.*, **3**, 305 (1913).  
 " Brannigan, Macbeth, and Stewart. *Trans.*, **103**, 406 (1913).  
 " Clarke and Stewart. *Phys. Zeit.*, **14**, 1049 (1913).  
 " Stark. *Phys. Zeit.*, **14**, 845 (1913).  
 " Bielecki and Henri. *Ber.*, **47**, 1690 (1914).  
 " " " *Compt. rend.*, **158**, 567, 1022 (1914).  
 " Henderson, Henderson and Heilbron. *Ber.*, **47**, 876 (1914).  
 " Rice. *Proc. Roy. Soc.*, **91A**, 76 (1914).  
 " Stark and Lipp. *Zeit. phys. Chem.*, **86**, 36 (1914).  
 Acetone-*p*-bromophenylhydrazone. Baly and Tuck. *Trans.*, **89**, 982 (1906).  
 Acetonedicarboxylic acid, ethyl ester. Baly and Desch. *Trans.*, **87**, 766 (1905).  
 " " " " Bielecki and Henri. *Ber.*, **46**, 2596 (1913).  
 Acetone-*p*-nitrophenylhydrazone. Baly and Tuck. *Trans.*, **89**, 982 (1906).  
 Acetonephenylhydrazone. Baly and Tuck. *Trans.*, **89**, 982 (1906).  
 Acetonephenylmethylhydrazone. Baly and Tuck. *Trans.*, **89**, 982 (1906).  
 Acetonitrile. Bielecki and Henri. *Compt. rend.*, **156**, 1860 (1913).  
 Acetylacetone. Baly and Desch. *Trans.*, **87**, 766 (1905).  
 " Stewart and Baly. *Trans.*, **89**, 489 (1906).  
 " Bielecki and Henri. *Compt. rend.*, **156**, 1322 (1913).  
 " " " *Ber.*, **46**, 3627 (1913).  
 " " " *Ber.*, **47**, 1690 (1914).  
 Acetophenone. Baly and Collie. *Trans.*, **87**, 1332 (1905).  
 " Purvis and McClelland. *Trans.*, **103**, 1088 (1913).  
 " Bielecki and Henri. *Ber.*, **47**, 1690 (1914).  
 " Baly and Tryhorn. *Trans.*, **107**, 1058 (1915).  
 Acetophenone-*p*-nitrophenylhydrazone. Hewitt, Johnson, and Pope. *Trans.*, **105**,  
**364** (1914).  
 Acetophenoneoxime. Crymble, Stewart, Wright, and Glendinning. *Trans.*, **99**,  
**451** (1911).  
 Acetophenonephenylhydrazone. Baly and Tuck. *Trans.*, **89**, 982 (1906).  
 Acetoxime. Hartley and Dobbie. *Trans.*, **77**, 318 (1900).  
 " Bielecki and Henri. *Compt. rend.*, **156**, 1860 (1913).  
 Acetoxymethylenecamphor. Lowry and Southgate. *Trans.*, **97**, 905 (1910).  
 Acetyl chloride. Hantzsch and Scharf. *Ber.*, **46**, 3570 (1913).  
 Acetylacetone. Baly and Desch. *Trans.*, **85**, 1029 (1904).  
 " Hartley. *Trans.*, **87**, 1796 (1905).  
 " Baly and Desch. *Astrophys. Journ.*, **23**, 110 (1906).  
 " Purvis and McClelland. *Trans.*, **101**, 1810 (1912).  
 " Bielecki and Henri. *Compt. rend.*, **156**, 1322 (1913).  
 " Morgan and Moss. *Trans.*, **103**, 78 (1913).  
 " Morgan and Reilly. *Trans.*, **103**, 1494 (1913).

- Acetylacetone. Bielecki and Henri. *Compt. rend.*, **158**, 1022 (1914).  
 " Henderson, Henderson, and Heilbron. *Ber.*, **47**, 876 (1914).  
 " metallic derivatives. Baly and Desch. *Trans.*, **85**, 1029 (1904);  
     *Astrophys. Journ.*, **23**, 110 (1906).  
     Morgan and Moss. *Trans.*, **105**, 189 (1914).
- Acetylaminoozobenzene. Tuck. *Trans.*, **95**, 1809 (1909).
- 3-Acetylaminophenazthionium chloride. Pummerer, Eckert, and Gassner. *Ber.*, **47**,  
 1494 (1914).  
 " " Eckert and Pummerer. *Zeit. phys. Chem.*,  
**87**, 599 (1914).
- Acetylauramine. Grandmougin and Favre-Ambrumyan. *Ber.*, **47**, 2127 (1914).
- p-Acetylbenzeneazophenol. Hewitt, Mann, and Pope. *Trans.*, **105**, 2193 (1914).
- p-Acetylbenzeneazophenolphenylhydrazone. Hewitt, Mann, and Pope. *Trans.*,  
**105**, 2193 (1914).
- p-Acetylbenzeneazo- $\alpha$ -naphthol. Hewitt, Mann, and Pope. *Trans.*, **105**, 2193  
 (1914).
- p-Acetylbenzeneazo- $\beta$ -naphthol. Hewitt, Mann, and Pope. *Trans.*, **105**, 2193  
 (1914).
- Acetylcamphor. Lowry and Southgate. *Trans.*, **97**, 905 (1910).
- Acetylene. Hartley. *Trans.*, **39**, 153 (1881).  
 " Henri and Landau. *Compt. rend.*, **156**, 697 (1913).  
 " Stark and Lipp. *Jahrb. Radioak.*, **10**, 175 (1913).  
 " " *Zeit. phys. Chem.*, **86**, 36 (1914).
- Acetylenedicarboxylic acid, ethyl ester. Bielecki and Henri. *Ber.*, **46**, 2596 (1913).
- Acetylglyoxalic acid, ethyl ester. Bielecki and Henri. *Ber.*, **47**, 1690 (1914).
- Acetylmethyl hexyl ketone. Henderson, Henderson, and Heilbron. *Ber.*, **47**, 876  
 (1914).
- Acetyl- $\beta$ -naphthaquinonephenylhydrazone. Tuck. *Trans.*, **95**, 1809 (1909).
- Acetyloxindone. Hantzsch. *Zeit. phys. Chem.*, **84**, 321 (1913).
- 3-Acetyl-1-phenyl-4-methyl-1,3-cyclobutadiene-2-carboxylic acid. Purvis. *Trans.*,  
**99**, 107 (1911).
- 5-Acetyl-3-phenyl-4-methyl- $\Delta^3$ -cyclopentene. Purvis. *Trans.*, **99**, 107 (1911).
- Acetylsuccinic acid, ethyl ester. Baly and Desch. *Trans.*, **87**, 766 (1905).
- $\alpha$ -4-Acetyl-3,4-tolylenediazoimide. Morgan and Micklethwait. *Trans.*, **103**, 1391  
 (1913).
- $\beta$ -4-Acetyl-3,4-tolylenediazoimide. Morgan and Micklethwait. *Trans.*, **103**, 1391  
 (1913).
- Acid brown. Hartley. *Trans.*, **51**, 152 (1887).
- Aconitic acid. Stewart. *Trans.*, **91**, 199 (1907).  
 " " Bielecki and Henri. *Ber.*, **46**, 2596 (1913).  
 " " *Compt. rend.*, **157**, 372 (1913).
- Aconitine. Hartley. *Phil. Trans.*, **176**, 471 (1885).
- $\psi$ -Aconitine. Hartley. *Phil. Trans.*, **176**, 471 (1885).
- Acraldehyde. Bielecki and Henri. *Ber.*, **46**, 3627 (1913).  
 " Purvis and McClelland. *Trans.*, **103**, 433 (1913).
- Acridine methiodide. Tinkler. *Trans.*, **89**, 856 (1906).
- $\alpha$ -Alanine. Soret. *Arch. des Sciences*, **10**, 429 (1883).  
 " salts of. Ley. *Ber.*, **42**, 354 (1909).  
 " " " Ley and Winkler. *Ber.*, **45**, 372 (1912).  
 " " " Ley and Hegge. *Ber.*, **48**, 70 (1915).
- $\beta$ -Alanine, copper salt of. Ley and Hegge. *Ber.*, **48**, 70 (1915).
- Alizarin. Meyer and Fischer. *Ber.*, **46**, 85 (1913).  
 " Hüttig. *Zeit. phys. Chem.*, **87**, 129 (1914).  
 " Meek and Watson. *Trans.*, **109**, 544 (1916).
- Alizarin-cyanine. Meek and Watson. *Trans.*, **109**, 544 (1916).
- Allantoin. Soret. *Arch. des Sciences*, **10**, 429 (1883).
- Allochrysoketone-1-carboxylic acid. Hantzsch. *Ber.*, **49**, 226 (1916).
- Allochrysoketonic acid and ester. Stobbe. *Ber.*, **48**, 441 (1915).
- Alloxan. Hartley. *Trans.*, **87**, 1796 (1905).  
 " potassium salt. Hartley. *Trans.*, **87**, 1796 (1905).
- Alloxantin. Hartley. *Trans.*, **87**, 1796 (1905).
- Allyl alcohol. Hartley. *Trans.*, **39**, 153 (1881).  
 " " Drossbach. *Ber.*, **35**, 1486 (1902).

- Allyl alcohol. Magini. *Nuovo Cim.*, **6**, 343 (1903).  
 " " Bielecki and Henri. *Ber.*, **46**, 2596 (1913).  
 " " Purvis and McClelland. *Trans.*, **103**, 433 (1913).  
 Allyl bromide. Purvis and McClelland. *Trans.*, **103**, 433 (1913).  
 Allyl isothiocyanate. Pflüger. *Phys. Zeit.*, **10**, 406 (1909).  
 Allylacetic acid. Bielecki and Henri. *Ber.*, **46**, 2596 (1913).  
 " " " " " " *Compt. rend.*, **157**, 372 (1913).  
 " " " " " " *Ber.*, **47**, 1690 (1914).  
 Allylacetone. Bielecki and Henri. *Ber.*, **46**, 3627 (1913).  
 " Purvis and McClelland. *Trans.*, **103**, 433 (1913).  
 " Bielecki and Henri. *Ber.*, **47**, 1690 (1914).  
 " " " " " " *Compt. rend.*, **158**, 567, 1022 (1914).  
*o*-Aminoacetophenone. Baly and Marsden. *Trans.*, **93**, 2108 (1908).  
*p*-Aminoacetophenone. Baly and Marsden. *Trans.*, **93**, 2108 (1908).  
 4-Aminoantipyrine. Morgan and Reilly. *Trans.*, **103**, 1494 (1913).  
*p*-Aminoazobenzene. Pauer. *Ann. der Phys.*, **61**, 363 (1897).  
 " Tuck. *Trans.*, **95**, 1809 (1909).  
 " Hewitt and Thole. *Trans.*, **97**, 511 (1910).  
 " Purvis. *Trans.*, **105**, 590 (1914).  
 " Baly and Hampson. *Trans.*, **107**, 248 (1915).  
 Aminoazo- $\alpha$ -naphthalene. Hartley. *Trans.*, **51**, 153 (1887).  
 Aminoazo- $\beta$ -naphthalene. Hartley. *Trans.*, **51**, 153 (1887).  
*o*-Aminobenzaldehyde. Baly and Marsden. *Trans.*, **93**, 2108 (1908).  
*p*-Aminobenzaldehyde. Baly and Marsden. *Trans.*, **93**, 2108 (1908).  
 " Purvis. *Trans.*, **103**, 1638 (1913).  
*o*-Aminobenzaldoxime. Baly and Marsden. *Trans.*, **93**, 2108 (1908).  
*p*-Aminobenzeneazodimethylaniline. Hantzsch. *Ber.*, **46**, 1537 (1913).  
 5-*p*-Aminobenzeneazo-8-hydroxyquinoline. Fox. *Trans.*, **97**, 1337 (1910).  
*p*-Aminobenzeneazophenol. Hewitt and Thomas. *Trans.*, **95**, 1292 (1909).  
*m*-Aminobenzoic acid. Magini. *Nuovo Cim.*, **6**, 343 (1903); *J. Chim. phys.*, **2**, 410 (1904).  
*o*-Aminobenzoic acid. Magini. *Nuovo Cim.*, **6**, 343 (1903); *J. Chim. phys.*, **2**, 410 (1904).  
*p*-Aminobenzoic acid. Magini. *Nuovo Cim.*, **6**, 343 (1903); *J. Chim. phys.*, **2**, 410 (1904).  
 Aminochloromaleinimide. Ley and Fischer. *Ber.*, **46**, 327 (1913).  
 $\beta$ -Aminocrotonic acid, ethyl ester. Baly and Desch. *Trans.*, **85**, 1029 (1904).  
 1-Amino-6-8(9)-dihydroxynaphthacenequinone. Baly and Tuck. *Trans.*, **91**, 426 (1907).  
 Aminodimethyldihydroresorcin. Baly and Ewbank. *Trans.*, **87**, 1347 (1905).  
*p*-Aminodiphenylaminediazonium sulphate. Hantzsch and Lifschitz. *Ber.*, **45**, 3011 (1912).  
 $\omega$ -Aminoethylpiperonylcarboxylic anhydride. Hartley, Dobbie, and Lauder. *Brit. Ass. Report*, 1903, 126.  
 " " Dobbie and Lauder. *Trans.*, **83**, 605 (1903).  
 1-Amino-6-hydroxynaphthacenequinone. Baly and Tuck. *Trans.*, **91**, 426 (1907).  
 Aminomethylenecamphor. Lowry and Southgate. *Trans.*, **97**, 905 (1910).  
 Aminomethylmaleinimide. Ley and Fischer. *Ber.*, **46**, 327 (1913).  
 $\alpha$ -Aminocottinic acid. Ley and Engelhardt. *Zeit. phys. Chem.*, **74**, 1 (1910).  
*m*-Aminophenol. Purvis. *Trans.*, **103**, 1638 (1913).  
*p*-Aminophenol. Baly and Ewbank. *Trans.*, **87**, 1347 (1905).  
 Aminophenyl-naphthophenazonium chloride. Havas. *Ber.*, **47**, 994 (1914).  
 Aminophenylphenazonium chloride. Havas. *Ber.*, **47**, 994 (1914).  
 $\alpha$ -Aminopyridine. Ley and v. Engelhardt. *Zeit. phys. Chem.*, **74**, 1 (1910).  
 Aminosulphonic acid. Baly and Desch. *Trans.*, **93**, 1747 (1908).  
 Ammonium thiocyanate. Macbeth, Stewart, and Wright. *Trans.*, **101**, 599 (1912).  
 Amyl acetate. Hantzsch and Scharf. *Ber.*, **46**, 3570 (1913).  
*n*-Amyl alcohol. Massol and Faucon. *Bull. Soc. Chim.*, **11**, 931 (1912).  
*tert*-Amyl alcohol. Massol and Faucon. *Bull. Soc. Chim.*, **11**, 931 (1912).  
 Amyl butyrate. Hartley and Huntington. *Phil. Trans.*, **170**, I. 257 (1879).  
 Amyl camphorcarboxylate. Lowry, Desch, and Southgate. *Trans.*, **97**, 899 (1910).  
 Amyl camphorcarboxylate, acetate of. Lowry, Desch, and Southgate. *Trans.*, **97**, 899 (1910).

- Amyl chlorocamphorcarboxylate. Lowry, Desch, and Southgate. *Trans.*, **97**, 899 (1910).
- Amyl formate. Hartley and Huntington. *Phil. Trans.*, **170**, I. 257 (1879).
- „ „ Hantzsch and Scharf. *Ber.*, **46**, 3570 (1913).
- Amyl iodide. Crymble, Stewart, and Wright. *Ber.*, **43**, 1183 (1910).
- Amyl nitrite. Baly and Desch. *Trans.*, **93**, 1747 (1908).
- „ „ Harper and Macbeth. *Trans.*, **107**, 87 (1915).
- Amyl propionate. Hartley and Huntington. *Phil. Trans.*, **170**, I. 257 (1879).
- Amyl salicylate. Pfüger. *Phys. Zeit.*, **10**, 406 (1909).
- Amylene. Hartley. *Trans.*, **39**, 153 (1881).
- Anhydrobisdibenzylsilicanediol. Robison and Kipping. *Trans.*, **105**, 40 (1914).
- Aniline. Hartley and Huntington. *Phil. Trans.*, **170**, I. 257 (1879).
- „ Pauer. *Ann. der Phys.*, **61**, 363 (1897).
- „ Baly and Collie. *Trans.*, **87**, 1332 (1905).
- „ Grebe. *Zeit. wiss. Phot.*, **3**, 376 (1905).
- „ Ley and Ulrich. *Ber.*, **42**, 3440 (1909).
- „ Koch. *Zeit. wiss. Phot.*, **9**, 401 (1910).
- „ Purvis. *Trans.*, **97**, 1546 (1910).
- „ Baly and Tryhorn. *Trans.*, **107**, 1058 (1915).
- „ Baly and Tryhorn. *Trans.*, **107**, 1121 (1915).
- „ Witte. *Zeit. wiss. Phot.*, **14**, 347 (1915).
- Anilinoacetic acid, ethyl ester. Ley and Ulrich. *Ber.*, **42**, 3440 (1909).
- „ copper salt. Ley and Hegge. *Ber.*, **48**, 70 (1915).
- „ sodium salt. Ley and Hegge. *Ber.*, **48**, 70 (1915).
- 1-Anilino-6-hydroxynaphthacenequinone. Baly and Tuck. *Trans.*, **91**, 426 (1907).
- Anisaldehyde. Pfüger. *Phys. Zeit.*, **10**, 406 (1909).
- „ Tuck. *Trans.*, **95**, 1809 (1909).
- „ Purvis. *Trans.*, **105**, 2482 (1914).
- Anisaldehydephenylhydrazone. Stobbe and Nowak. *Ber.*, **46**, 2887 (1913).
- Anisaldehydephenylmethylhydrazone. Tuck. *Trans.*, **95**, 1809 (1909).
- o*-Anisidine. Baly and Ewbank. *Trans.*, **87**, 1347 (1905).
- „ Purvis. *Trans.*, **107**, 660 (1915).
- p*-Anisidine. Baly and Ewbank. *Trans.*, **87**, 1347 (1905).
- „ Purvis. *Trans.*, **107**, 660 (1915).
- Anisole. Hartley and Huntington. *Phil. Trans.*, **170**, I. 257 (1879).
- „ Baly and Collie. *Trans.*, **87**, 1332 (1905).
- „ Baly and Ewbank. *Trans.*, **87**, 1347 (1905).
- „ Baly and Rice. *Trans.*, **101**, 1475 (1912).
- „ Purvis and McClelland. *Trans.*, **101**, 1514 (1912).
- „ Purvis. *Trans.*, **107**, 660 (1915).
- „ Baly and Tryhorn. *Trans.*, **107**, 1058 (1915).
- „ Witte. *Zeit. wiss. Phot.*, **14**, 347 (1915).
- Anisole diazoniumcyanide. Hantzsch and Lifschitz. *Ber.*, **45**, 3011 (1912).
- Anisylideneacetone. Baker. *Trans.*, **91**, 1490 (1907).
- Anthracene. Hartley. *Trans.*, **39**, 153 (1881).
- „ Elston. *Astrophys. Journ.*, **25**, 155 (1907).
- „ Baly and Tuck. *Trans.*, **93**, 1902 (1908).
- „ McDowell. *Phys. Rev.*, **26**, 155 (1908).
- „ Stevenson. *J. Phys. Chem.*, **15**, 845 (1911).
- Anthracene-blue. Meek and Watson. *Trans.*, **109**, 544 (1916).
- Anthraflavine. Meyer and Fischer. *Ber.*, **46**, 85 (1913).
- iso*-Anthraflavine. Meyer and Fischer. *Ber.*, **46**, 85 (1913).
- Anthragallol. Meyer and Fischer. *Ber.*, **46**, 85 (1913).
- „ Meek and Watson. *Trans.*, **109**, 544 (1916).
- Anthranil. Scheiber. *Ber.*, **44**, 2409 (1911).
- Anthraquinone. Baly and Stewart. *Trans.*, **89**, 502 (1906).
- „ Meyer and Fischer. *Ber.*, **46**, 85 (1913).
- Anthrarufine. Meyer and Fischer. *Ber.*, **46**, 85 (1913).
- Anthroxanic acid. Scheiber. *Ber.*, **44**, 2409 (1911).
- Antipyrine-4-azo- $\beta$ -naphthylamine. Morgan and Reilly. *Trans.*, **103**, 1494 (1913).
- Antipyrine-4-azo- $\beta$ -naphthylamine-6'-sulphonic acid. Morgan and Reilly. *Trans.*  
*loc. cit.*
- Antipyrine-4-azoacetoacetic acid, ethyl ester. Morgan and Reilly. *Trans. loc. cit.*

- Antipyrine-4-azoacetylacetone. Morgan and Reilly. Trans. *loc. cit.*  
 Antipyrine-4-azobenzoylacetone. Morgan and Reilly. Trans. *loc. cit.*  
 Antipyrine-4-azoethyl methyl ketone. Morgan and Reilly. Trans. *loc. cit.*  
 Antipyrine-4-azoethyl- $\beta$ -naphthylamine. Morgan and Reilly. Trans. *loc. cit.*  
 Apiole. Crymble, Stewart, Wright, and Glendinning. Trans., **99**, 451 (1911).  
*iso*-Apiole. Crymble, Stewart, Wright, and Glendinning. Trans., **99**, 451 (1911).  
 Apotropine. Gompel and Henri. Compt. rend., **156**, 1541 (1913).  
 Apomorphine. Hartley. Phil. Trans., **176**, 471 (1885).  
 „ Gompel and Henri. Compt. rend., **157**, 1422 (1913).  
 Arsenic triphenyl. Purvis and McClelland. Trans., **101**, 1514 (1912).  
 Asparagine. Magini. J. Chim. phys., **2**, 410 (1904).  
 Atropic acid. Crymble, Stewart, Wright, and Glendinning. Trans., **99**, 451 (1911).  
 Atropine. Hartley. Phil. Trans., **176**, 471 (1885).  
 „ Dobbie and Fox. Trans., **103**, 1193 (1913).  
 „ Gompel and Henri. Compt. rend., **156**, 1541 (1913).  
 Auramine. Grandmougin and Favre-Ambrunyan. Ber., **47**, 2127 (1914).  
 Aurine. Hartley. Trans., **51**, 153 (1887).  
 Australine. Hartley and Huntington. Proc. Roy. Soc., **31**, 1 (1880).  
 Azobenzene. Hartley. Trans., **51**, 152 (1887).  
 „ Pauer. Ann. der Phys., **61**, 363 (1897).  
 „ Baly and Tuck. Trans., **89**, 982 (1906).  
 „ Tuck. Trans., **91**, 449 (1907).  
 „ Gorke, Köppe, and Staiger. Ber., **41**, 1156 (1908).  
 „ Hantzsch. Ber., **42**, 2129 (1909).  
 „ Crymble, Stewart, and Wright. Ber., **43**, 1188 (1910).  
 „ Hantzsch and Lifschitz. Ber., **45**, 3011 (1912).  
 „ Purvis and McClelland. Trans., **101**, 1514 (1912).  
 „ Hantzsch. Ber., **46**, 1537 (1913).  
 „ Purvis. Trans., **105**, 590 (1914).  
 „ Baly and Hampson. Trans., **107**, 248 (1915).  
 Azobenzenetrimethylammonium salts. See Benzeneazophenyltrimethylammonium salts.  
 Azoisobutyronitrile. Hantzsch and Lifschitz. Ber., **45**, 3011 (1912).  
 Azodicarbonamide. „ „ „ Ber., **45**, 3011 (1912).  
 Azodicarboxylic acid, potassium salt. Hantzsch and Lifschitz. Ber., **45**, 3011 (1912).  
 Azomethane. Hantzsch and Lifschitz. Ber., **45**, 3011 (1912).  
 Azophenetole. Tuck. Trans., **95**, 1809 (1909).  
*p*-Azophenol. Tuck. Trans., **95**, 1809 (1909).  
 $\alpha$ -*p*-Azophenol. Robertson. Trans., **103**, 1472 (1913).  
 $\beta$ -*p*-Azophenol. Robertson. Trans., **103**, 1472 (1913).  
 Azophenol hydrate. Hantzsch. Ber., **43**, 2512 (1910).  
 Azophenol sodium salt. Hantzsch. Ber., **43**, 2512 (1910).  
 Azoxyanisole. Purvis. Trans., **107**, 660 (1915).  
 Azoxybenzene. Purvis. Trans., **105**, 590 (1914).  
 Azoxyphenetole. Purvis. Trans., **107**, 660 (1915).

## B

- Barbituric acid. Hartley. Trans., **87**, 1796 (1905).  
 Benzaldehyde. Baly and Collie. Trans., **87**, 1332 (1905).  
 „ Pfüger. Phys. Zeit., **10**, 406 (1909).  
 „ Purvis and McClelland. Trans., **103**, 1088 (1913).  
 „ Bielecki and Henri. Ber., **47**, 1690 (1914).  
 „ Baly and Tryhorn. Trans., **107**, 1058, 1121 (1915).  
 „ Strasser. Zeit. wiss. Phot., **14**, 281 (1915).  
 Benzaldehyde sodium hydrogen sulphite. Purvis. Trans., **105**, 2482 (1914).  
 Benzaldehyde-*p*-nitrophenylhydrazone. Hewitt, Johnson, and Pope. Trans., **105**, 364 (1914).  
 Benzaldehydephenylhydrazone. Baly and Tuck. Trans., **89**, 982 (1906).  
 „ Stobbe and Nowak. Ber., **46**, 2887 (1913).  
 Benzaldehydephenylmethylhydrazone. Baly and Tuck. Trans., **89**, 982 (1906).  
 Benzaldoxime. Hartley and Dobbie. Trans., **77**, 509 (1900).  
 „ Purvis. Trans., **105**, 2482 (1914).

- Benzamide.** Hartley and Hedley. *Trans.*, **91**, 319 (1907).  
**Benzanilide.** Crymble, Stewart, Wright, and Glendinning. *Trans.*, **99**, 451 (1911).  
**Benzaurine.** Meyer and Hantzsch. *Ber.*, **40**, 3479 (1907).  
 " Meyer and Fischer. *Ber.*, **46**, 70 (1913).  
**o-Benzbetain.** Ley and Ulrich. *Ber.*, **42**, 3440 (1909).  
**Benzene.** Hartley and Huntington. *Phil. Trans.*, **170**, I. 257 (1879).  
 " Hartley. *Trans.*, **39**, 153 (1881); **47**, 685 (1885).  
 " Pauer. *Ann. der Phys.*, **61**, 363 (1897).  
 " Hartley and Dobbie. *Trans.*, **73**, 695 (1898).  
 " Baly and Collie. *Trans.*, **87**, 1332 (1905).  
 " " *Nature*, **72**, 630 (1905).  
 " Hartley. *Nature*, **72**, 557 (1905).  
 " Friedrichs. *Zeit. wiss. Phot.*, **3**, 154 (1905).  
 " Grebe. *Zeit. wiss. Phot.*, **3**, 376 (1905).  
 " Hartley. *Phil. Trans.*, **208 A.**, 475 (1908); *Zeit. wiss. Phot.*, **6**, 299 (1908).  
 " Grebe. *Zeit. wiss. Phot.*, **9**, 130 (1910).  
 " v. Kowalski. *Bull. Akad. Sci., Cracovie*, **1A**, 17 (1910).  
 " Ley and v. Engelhardt. *Zeit. phys. Chem.*, **74**, 1 (1910).  
 " Dickson. *Zeit. wiss. Phot.*, **10**, 166 (1911).  
 " Stark and Levy. *Jahrb. Radioak.*, **10**, 179 (1913).  
 " Stark and Lipp. *Zeit. phys. Chem.*, **86**, 36 (1914).  
 " Witte. *Zeit. wiss. Phot.*, **14**, 347 (1915).  
**Benzene hexachloride.** Hartley. *Trans.*, **39**, 153 (1881).  
**Benzeneazoanisole.** Gorke, Köppe, and Staiger. *Ber.*, **41**, 1156 (1908).  
**Benzeneazobenzenediazonium chloride.** Hewitt and Thole. *Trans.*, **97**, 511 (1910).  
**Benzeneazocarbamide.** Hantzsch and Lifschitz. *Ber.*, **45**, 3011 (1912).  
**Benzeneazocarbonylcoumaranone.** Merriman. *Trans.*, **103**, 1845 (1913).  
**Benzeneazocarbonylcoumaranone, acetyl derivative.** Merriman. *Trans.*, **103**, 1845, (1913).  
**Benzeneazocarbonylcoumaranonephenylhydrazone, acetyl derivative.** Merriman. *Trans.*, **103**, 1845 (1913).  
**Benzeneazo-*m*-cresetole.** Tuck. *Trans.*, **91**, 449 (1907).  
**Benzeneazo-*p*-cresetole.** Tuck. *Trans.*, **91**, 449 (1907).  
**Benzeneazo-*m*-cresol.** Tuck. *Trans.*, **91**, 449 (1907).  
**Benzeneazo-*p*-cresol.** Tuck. *Trans.*, **91**, 449 (1907).  
**Benzeneazo-2'6-dibromophenol.** Hantzsch and Robertson. *Ber.*, **43**, 106 (1910).  
**Benzeneazoethane.** Hantzsch and Lifschitz. *Ber.*, **45**, 3011 (1912).  
 " Stobbe and Nowak. *Ber.*, **46**, 2887 (1913); **47**, 578 (1914).  
**5-Benzeneazo-8-hydroxyquinoline.** Fox. *Trans.*, **97**, 1337 (1910).  
**Benzeneazomethane.** Baly and Tuck. *Trans.*, **89**, 982 (1906).  
 " Hantzsch and Lifschitz. *Ber.*, **45**, 3011 (1912).  
 " Stobbe and Nowak. *Ber.*, **47**, 578 (1914).  
**Benzeneazo- $\alpha$ -naphthol.** Tuck. *Trans.*, **95**, 1809 (1909).  
**Benzeneazo- $\alpha$ -naphthol, ethyl ether.** Tuck. *Trans.*, **95**, 1809 (1909).  
**Benzeneazo- $\beta$ -naphthol.** Tuck. *Trans.*, **95**, 1809 (1909).  
 " sulphonic acid. Hartley. *Trans.*, **51**, 152 (1887).  
**Benzeneazo- $\alpha$ -naphthyl acetate.** Tuck. *Trans.*, **95**, 1809 (1909).  
**Benzeneazo- $\beta$ -naphthyl acetate.** Tuck. *Trans.*, **95**, 1809 (1909).  
**Benzeneazophenetole.** Tuck. *Trans.*, **91**, 449 (1907).  
 " Gorke, Köppe, and Staiger. *Ber.*, **41**, 1156 (1908).  
 " Hantzsch and Robertson. *Ber.*, **43**, 106 (1910).  
 " Heilbron and Henderson. *Trans.*, **103**, 1404 (1913).  
**Benzeneazophenol.** Tuck. *Trans.*, **91**, 449 (1907).  
 " Gorke, Köppe, and Staiger. *Ber.*, **41**, 1156 (1908).  
 " Hantzsch. *Ber.*, **42**, 2129 (1909).  
 " Hantzsch and Robertson. *Ber.*, **43**, 106 (1910).  
 " Robertson and Brady. *Trans.*, **103**, 1479 (1913).  
**Benzeneazophenol, butyl ether.** Gorke, Köppe, and Staiger. *Ber.*, **41**, 1156 (1908).  
 " ethyl ether. " " " " " "  
 " methyl ether. " " " " " "  
 " phenyl ether. " " " " " "  
 " propyl ether. " " " " " "  
**Benzeneazophenol acetate.** " " " " " "

- Benzeneazophenol benzoate. Gorke, Köppe, and Staiger. Ber. **41**, 1156 (1908).  
 " butyrate. " " " " " "  
 " propionate. " " " " " "  
 Benzeneazophenyltrimethylammonium chloride. Hewitt and Thole. Trans., **97**, 511 (1910).  
 " " Hantzsch. Ber., **48**, 167 (1915).  
 " iodide. Hantzsch. Ber., **42**, 2129 (1909).  
 " " Baly and Hampson. Trans., **107**, 248 (1915).  
 " salts. Hantzsch. Ber., **46**, 1537 (1913).  
 Benzeneazothioanisole. Fox and Pope. Trans., **101**, 1498 (1912).  
 Benzenediazohydrate, potassium salt. Dobbie and Tinkler. Trans., **87**, 273 (1905).  
 " sodium salt. Hantzsch and Lifschitz. Ber., **45**, 3011 (1912).  
 Benzenediazonium chloride. Hantzsch and Lifschitz. Ber., **45**, 3011 (1912).  
 Benzenediazoniumsulphonic acids, salts of *syn* and *anti*. Dobbie and Tinkler. Trans., **87**, 273 (1905).  
 " " " " " " Hantzsch and Lifschitz. Ber., **45**, 3011 (1912).  
 Benzenehydrazocarbonylcoumaranone. Merriman. Trans., **103**, 1845 (1913).  
 Benzenesulphonic acid. Wright. Trans., **105**, 669 (1914).  
 Benzidine. Cain, Macbeth, and Stewart. Trans., **103**, 568 (1913).  
 " Purvis. Trans., **105**, 590 (1914).  
 Benzil. Baly and Stewart. Trans., **89**, 502 (1906).  
 " Hantzsch and Schuviète. Ber., **49**, 213 (1916).  
 Benzil-*o*-carboxylic acid. Hantzsch and Schuviète. Ber., **49**, 213 (1916).  
 Benzil-*o*-dicarboxylic acid. Hantzsch and Schuviète. Ber., **49**, 213 (1916).  
 Benzilosazone. Baly, Tuck, Marsden, and Gazdar. Trans., **91**, 1572 (1907).  
 Benziloxime. Hantzsch. Ber., **43**, 1651 (1910).  
 Benzilphenylhydrazone. Baly, Tuck, Marsden, and Gazdar. Trans., **91**, 1572 (1907).  
 Benzilphenylmethylhydrazone. Baly, Tuck, Marsden, and Gazdar. Trans., **91**, 1572 (1907).  
 Benzoic acid. Hartley and Huntington. Phil. Trans., **170**, I. 257 (1879).  
 " " Hartley and Hedley. Trans., **91**, 1572 (1907).  
 " " Dobbie and Fox. Trans., **103**, 1193 (1913).  
 " " Merriman. Trans., **103**, 1845 (1913).  
 " " Purvis. Trans., **107**, 966 (1915).  
 " " Strasse. Zeit. wiss. Phot., **14**, 281 (1915).  
 " " Hantzsch. Ber., **49**, 226 (1916).  
 " " salts of. Hartley and Hedley. Trans., **91**, 319 (1907).  
 " " " " Hewitt, Pope, and Willett. Trans., **101**, 1770 (1912).  
 " " " " Wright. Trans., **103**, 528 (1913).  
 Benzoimphenylhydrazone. Baly, Tuck, Marsden, and Gazdar. Trans., **91**, 1572 (1907).  
 Benzonitrile. Baly and Collie. Trans., **87**, 1332 (1905).  
 " Strasser. Zeit. wiss. Phot., **14**, 281 (1915).  
 " Purvis. Trans., **107**, 496 (1915).  
 " Baly and Tryhorn. Trans., **107**, 1058 (1915).  
 Benzophenone. Stobbe. Ber., **44**, 1481 (1911).  
 " Purvis and McClelland. Trans., **101**, 1514 (1912).  
 " " " " Trans., **103**, 1088 (1913).  
 " Baly and Tryhorn. Trans., **107**, 1058 (1915).  
 " Hantzsch and Schuviète. Ber., **49**, 213 (1916).  
 Benzophenoneanil hydrochloride. Reddelien. Ber., **47**, 1355 (1914).  
 Benzophenoneoxime. Crymble, Stewart, Wright, and Glendinning. Trans., **99**, 451 (1911).  
 " Lifschitz. Ber., **46**, 3233 (1913).  
*p*-Benzoquinone. Lifschitz and Jenner. Ber., **48**, 1730 (1915).  
 " Hartley. Trans., **53**, 641 (1888).  
 " Soret. Arch. des Sciences, **10**, 429 (1883).  
 " Hartley, Dobbie, and Lauder. Brit. Ass. Report, 1902, 99.  
 " Baly and Stewart. Trans., **89**, 502 (1906).  
 " Stewart and Baly. Trans., **89**, 618 (1906).  
 " Hartley and Leonard. Trans., **95**, 34 (1909).  
 " Hantzsch. Ber., **49**, 511 (1915).



- p*-Benzoquinoneazine. Baly, Tuck, and Marsden. *Trans.*, **97**, 1494 (1910).  
*p*-Benzoquinonebenzoylphenylhydrazone. Tuck. *Trans.*, **91**, 449 (1907).  
*p*-Benzoquinonechlorimide. Hartley, Dobbie, and Lauder. *Brit. Ass. Report*, 1902, 99.  
*p*-Benzoquinonediazide. Hantzsch and Lifschitz. *Ber.*, **45**, 3011 (1912).  
 " Cain. *Ber.*, **46**, 101 (1913).  
*p*-Benzoquinonedichlorimide. Hartley, Dobbie, and Lauder. *Brit. Ass. Report*, 1902, 99.  
*p*-Benzoquinonedioxime. Hartley, Dobbie, and Lauder. *Brit. Ass. Report*, 1902, 99.  
*p*-Benzoquinonehydrone. Lifschitz and Jenner. *Ber.*, **48**, 1730 (1915).  
 Benzoyl chloride. Purvis. *Trans.*, **105**, 2482 (1914).  
 Benzoylactic acid, ethyl ester. Baly and Desch. *Trans.*, **87**, 766 (1905).  
 Benzoylacetone. Baly and Desch. *Trans.*, **87**, 766 (1905).  
 " Morgan and Moss. *Trans.*, **103**, 78 (1913).  
 " aluminium derivative. Baly and Desch. *Trans.*, **87**, 766 (1905).  
 Benzoylazobenzene. Merriman. *Trans.*, **103**, 1845 (1913).  
 Benzoylazo-*p*-cresetole. Tuck. *Trans.*, **91**, 449 (1907).  
 Benzoylbenzeneazo-*p*-cresol. Tuck. *Trans.*, **91**, 449 (1907).  
*p*-Benzoylbenzeneazo-*p*-cresol. Hewitt, Mann, and Pope. *Trans.*, **105**, 2193 (1914).  
*p*-Benzoylbenzeneazo- $\alpha$ -naphthol. Hewitt, Mann, and Pope. *Trans.*, **105**, 2193 (1914).  
*p*-Benzoylbenzeneazo- $\beta$ -naphthol. Hewitt, Mann, and Pope. *Trans.*, **105**, 2193 (1914).  
 Benzoylbenzeneazophenol. Tuck. *Trans.*, **91**, 449 (1907).  
*p*-Benzoylbenzeneazophenol. Hewitt, Mann, and Pope. *Trans.*, **105**, 2193 (1914).  
*o*-Benzoylbenzoic acid, salts and ethyl ester of. Hantzsch and Schuviète. *Ber.*, **49**, 213 (1916).  
 Benzoylcarbinolphenylhydrazone. Baly, Tuck, Marsden, and Gazdar. *Trans.*, **91**, 1572 (1907).  
 Benzoyldianilinostilbene. Everet and McCombie. *Trans.*, **99**, 1752 (1911).  
*s*-Benzoylphenylhydrazine. Merriman. *Trans.*, **103**, 1845 (1913).  
 Benzoylpiperidine. Purvis. *Trans.*, **103**, 2283 (1913).  
 Benzoylsuccinic acid, ethyl ester. Baly and Desch. *Trans.*, **87**, 766 (1905); *As-trophys. Journ.*, **23**, 110 (1906).  
 Benzyl acetate. Pflüger. *Phys. Zeit.*, **10**, 406 (1909).  
 Benzyl alcohol. Baly and Collie. *Trans.*, **87**, 1332 (1905).  
 " " Pflüger. *Phys. Zeit.*, **10**, 406 (1909).  
 " " Purvis. *Trans.*, **107**, 496 (1915).  
 " " Baly and Tryhorn. *Trans.*, **107**, 1058 (1915).  
 " " Strasser. *Zeit. wiss. Phot.*, **14**, 281 (1915).  
 Benzyl benzoate. Pflüger. *Phys. Zeit.*, **10**, 406 (1909).  
 Benzyl chloride. Purvis. *Trans.*, **107**, 496 (1915).  
 Benzyl cyanide. *See* Phenylacetoneitrile.  
 Benzyl ethyl ether. Baly and Collie. *Trans.*, **87**, 1332 (1905).  
 " " " Baly and Tryhorn. *Trans.*, **107**, 1058 (1915).  
 " " " Strasser. *Zeit. wiss. Phot.*, **14**, 281 (1915).  
 Benzylacetophenone. Stobbe and Ebert. *Ber.*, **44**, 1289 (1911).  
 Benzylamine. Purvis. *Trans.*, **97**, 1546 (1910).  
 Benzylaniline. Purvis and McClelland. *Trans.*, **101**, 1514 (1912).  
 Benzylidene chloride. Purvis. *Trans.*, **105**, 2482 (1914).  
 Benzylideneacetone. Baker. *Trans.*, **91**, 1490 (1907).  
 " Baly and Schaefer. *Trans.*, **93**, 1808 (1908).  
 Benzylideneacetophenone. Stobbe and Ebert. *Ber.*, **44**, 1289 (1911).  
 Benzylideneaminoazobenzene. Pope and Willett. *Trans.*, **103**, 1258 (1913).  
 Benzylideneaniline. Baly, Tuck, and Marsden. *Trans.*, **97**, 571 (1910).  
 Benzylideneanisylideneacetone. Baker. *Trans.*, **91**, 1490 (1907).  
 Benzylidene-camphor. Lowry and Southgate. *Trans.*, **97**, 905 (1910).  
 Benzylidene-malonic acid. Baly and Schaefer. *Trans.*, **93**, 1808 (1908).  
 Benzylidene-*m*-nitroaniline. Baly, Tuck, and Marsden. *Trans.*, **97**, 571 (1910).  
 Benzylidene-*p*-nitroaniline. Baly, Tuck, and Marsden. *Trans.*, **97**, 571 (1910).  
 Berberidic acid. Dobbie and Lauder. *Trans.*, **83**, 605 (1903).  
 " Hartley, Dobbie, and Lauder. *Brit. Ass. Report*, 1903, 126.  
 Berberine. Dobbie and Lauder. *Trans.*, **83**, 605 (1903).  
 " Hartley, Dobbie, and Lauder. *Brit. Ass. Report*, 1903, 126.

- Berberine. Tinkler. Trans., **99**, 1340 (1911).  
 Biebrich scarlet. Hartley. Trans., **51**, 152 (1887).  
 Bis(anisylidenemethyl)pyrone. Boon, Wilson, and Heilbron. Trans., **105**, 2176 (1914).  
 „ salts. Boon, Wilson, and Heilbron. Trans., **105**, 2176 (1914).  
 „ tetrabromo derivative. Boon, Wilson, and Heilbron. Trans., **105**, 2176 (1914).  
 Bisbenzeneazodiphenol. Robertson and Brady. Trans., **103**, 1479 (1913).  
 Bis(benzylidenemethyl)pyrone. Boon, Wilson, and Heilbron. Trans., **105**, 2176 (1914).  
 „ salts. Boon, Wilson, and Heilbron. Trans., **105**, 2176 (1914).  
 2,3-Bis(*p*-dimethylaminoanilo)- $\alpha$ -hydrindone. Purvis. Trans., **99**, 1953 (1911).  
 Bis(furfurylidenemethyl)pyrone. Boon, Wilson, and Heilbron. Trans., **105**, 2176 (1914).  
 „ salts. Boon, Wilson, and Heilbron. Trans., **105**, 2176 (1914).  
 Bismarck brown. Hartley. Trans., **51**, 152 (1887).  
 Bistolueneazodiphenol. Robertson and Brady. Trans., **103**, 1479 (1913).  
 Biuret. Soret. Arch. des Sciences, **10**, 429 (1883).  
 Borneol. Hantzsch. Ber., **45**, 553 (1912).  
 Bornylene. Stark, Steubing, Enklaar, and Lipp. Jahrb. Radioak., **10**, 139 (1913).  
 Brassidic acid. Macbeth, Stewart, and Wright. Trans., **101**, 599 (1912).  
 4-Bromoacenaphthene. Purvis. Trans., **101**, 1315 (1912).  
*m*-Bromoaniline. Purvis. Trans., **103**, 1638 (1913).  
*o*-Bromoaniline. Purvis. Trans., **103**, 1638 (1913).  
*p*-Bromoaniline. Purvis. Trans., **103**, 1638 (1913).  
*p*-Bromoanisole. Purvis. Trans., **107**, 660 (1915).  
 Bromobenzene. Pauer. Ann. der Phys., **61**, 363 (1897).  
 „ Grebe. Zeit. wiss. Phot., **3**, 376 (1905).  
 „ Stewart and Baly. Trans., **89**, 618 (1906).  
 „ Ley and v. Engelhardt. Zeit. phys. Chem., **74**, 1 (1910).  
 „ Purvis. Trans., **99**, 811 (1911).  
 „ Witte. Zeit. wiss. Phot., **14**, 347 (1915).  
*p*-Bromobenzenediazonium sulphate. Hantzsch and Lifschitz. Ber., **45**, 3011 (1912).  
*p*-Bromobenzoic acid and sodium salt. Hewitt, Pope, and Willett. Trans., **101**, 1770 (1912).  
 Bromo-*p*-benzoquinone. Stewart and Baly. Trans., **89**, 618 (1906).  
 $\alpha$ -Bromocamphor. Lowry and Desch. Trans., **95**, 807, 1340 (1909).  
 $\beta$ -Bromocamphor. Lowry and Desch. Trans., **95**, 807 (1909).  
 Bromocamphorcarboxylicamide. Lowry, Desch, and Southgate. Trans., **97**, 899 (1910).  
 Bromocamphorcarboxylicpiperidide. Lowry, Desch, and Southgate. Trans., **97**, 899 (1910).  
 $\alpha$ -Bromocamphor- $\beta$ -sulpho-*p*-bromoanilide. Lowry and Desch. Trans., **95**, 1340 (1909).  
 $\alpha$ -Bromocamphor- $\pi$ -sulphonamide. Lowry and Desch. Trans., **95**, 1340 (1909).  
 $\alpha$ -Bromocamphor- $\pi$ -sulphonic acid, ammonium salt of. Lowry and Desch. Trans., **95**, 1340 (1909).  
 $d$ - $\alpha$ -Bromocamphor- $\beta$ -sulphonic acid, ammonium salt of. Purvis. Trans., **107**, 643 (1915).  
 Bromodinitromethane. Hedley. Ber., **41**, 1195 (1908).  
 „ Harper and Macbeth. Trans., **107**, 87 (1915).  
 Bromoformylcamphor. Lowry and Southgate. Trans., **97**, 905 (1910).  
 3-Bromo-4-hydroxy-2-methyl-5-isopropylbenzeneazoforamide. Heilbron and Henderson. Trans., **103**, 1404 (1913).  
 5-Bromo-4-hydroxy-*m*-tolueneazoforamide. Heilbron and Henderson. Trans., **103**, 1404 (1913).  
 Bromomaleinamide. Ley and Fischer. Ber., **46**, 327 (1913).  
 $\alpha$ -Bromomethylcamphor. Lowry and Desch. Trans., **95**, 807 (1909).  
 $\beta$ -Bromomethylcamphor. „ „ „ „ „ „  
 $\omega$ -Bromomethylcamphor. „ „ „ „ „ „

- $\alpha$ -Bromonaphthalene. Purvis. Trans., **101**, 1315 (1912).  
 $\beta$ -Bromonaphthalene. Purvis. Trans., **101**, 1315 (1912).  
 $\alpha\alpha'$ -Bromonitrocaphor. Lowry and Desch. Trans., **95**, 807 (1909).  
 $\beta$ -Bromonitrocaphor. Lowry and Desch. Trans., **95**, 807 (1909).  
 $\pi$ -Bromonitrocaphor. Lowry and Desch. Trans., **95**, 807 (1909).  
 Bromonitromalonic acid, ethyl ester. Hantzsch and Voigt. Ber., **45**, 85 (1912).  
 $p$ -Bromophenetole. Purvis. Trans., **107**, 660 (1915).  
 $p$ -Bromophenol. Purvis. Trans., **103**, 1638 (1913).  
 $p$ -Bromophenylhydrazine. Baly and Tuck. Trans., **89**, 982 (1906).  
 $p$ -Bromophenyloximidoxazolone. Hantzsch and Heilbron. Ber., **43**, 68 (1910).  
 " acetyl derivative. Hantzsch and Heilbron. Ber., **43**, 68 (1910).  
 " methyl ether. Hantzsch and Heilbron. Ber., **43**, 68 (1910).  
 $m$ -Bromotoluene. Purvis. Trans., **99**, 1699 (1911).  
 $o$ -Bromotoluene. Purvis. Trans., **99**, 1699 (1911).  
 Brucine. Hartley. Phil. Trans., **176**, 471 (1885).  
 Bulbocapnine. Dobbie and Lauder. Trans., **83**, 605 (1903).  
 " Hartley, Dobbie, and Lauder. Brit. Ass. Report, 1903, 126.  
 Butyl acetate. Bielecki and Henri. Compt. rend., **155**, 456, 1617 (1912); Ber., **45**, 2819 (1912); **46**, 1304 (1913).  
*iso*Butyl acetate. Hartley and Huntington. Phil. Trans., **170**, I. 257 (1879).  
*iso*Butyl alcohol. Hartley. Trans., **39**, 153 (1881).  
 $n$ -Butyl alcohol. Bielecki and Henri. Ber., **45**, 2819 (1912); Compt. rend., **155**, 456 (1912).  
 " Massol and Faucon. Bull. Soc. Chim., **11**, 931 (1912).  
*tert*Butyl alcohol. Massol and Faucon. Bull. Soc. Chim., **11**, 931 (1912).  
*iso*Butyl butyrate. Hartley and Huntington. Phil. Trans., **170**, I. 257 (1879).  
*iso*Butyl formate. Hartley and Huntington. Phil. Trans., **170**, I. 257 (1879).  
*iso*Butyl iodide. Crymble, Stewart, and Wright. Ber., **43**, 1183 (1910).  
*iso*Butyl valerate. Hartley and Huntington. Phil. Trans., **170**, I. 257 (1879).  
*tert*Butylbenzene. Baly and Collie. Trans., **87**, 1332 (1905).  
 " Baly and Tryhorn. Trans., **107**, 1058 (1915).  
*iso*Butylene. Stark, Steubing, Enklaar, and Lipp. Jahrb. Radioak., **10**, 139 (1913).  
 Butyraldehyde. Bielecki and Henri. Compt. rend., **155**, 456 (1912); Ber., **45**, 2819 (1912); **46**, 3627 (1913).  
*iso*Butyric acid. Hartley and Huntington. Phil. Trans., **170**, I. 257 (1879).  
 $n$ -Butyric acid. Hartley and Huntington. Phil. Trans., **170**, I. 257 (1879).  
 " " Stewart. Trans., **91**, 199 (1907).  
 " " Bielecki and Henri. Compt. rend., **155**, 456, 1617 (1912); **156**, 550 (1913); Ber., **45**, 2819 (1912); **46**, 1304 (1913).  
 " " Hantzsch and Scharf. Ber., **46**, 3570 (1913).  
 " " Wright. Trans., **103**, 528 (1913); **105**, 669 (1914).  
 " " salts. Hantzsch and Scharf. Ber., **46**, 3570 (1913).  
 " " Wright. Trans., **103**, 528 (1913); **105**, 669 (1914).  
 Butyrylcaphor. Lowry and Southgate. Trans., **97**, 905 (1910).

## C

- Caffeine. Hartley. Phil. Trans., **176**, I. 471 (1885); Trans., **87**, 1796 (1905).  
 Camphene. Stark, Steubing, Enklaar, and Lipp. Jahrb. Radioak., **10**, 139 (1913).  
 Camphor. Hartley. Trans., **39**, 153 (1881).  
 " Baly, Marsden, and Stewart. Trans., **89**, 966 (1906).  
 " Hartley. Trans., **93**, 961 (1908).  
 " Lowry and Desch. Trans., **95**, 807 (1909).  
 " Lowry and Southgate. Trans., **97**, 907 (1910).  
 " Henderson, Henderson, and Heilbron. Ber., **47**, 876 (1914).  
 " Purvis. Trans., **107**, 643 (1915).  
 Camphor- $\beta$ -anhydramide. Lowry and Desch. Trans., **95**, 1340 (1909).  
 Camphorcarboxylic acid. Lowry, Desch, and Southgate. Trans., **97**, 899 (1910).  
 " amide " " " " " "  
 " ethyl ester " " " " " "  
 " metallic salts " " " " " "

- Camphorcarboxylic methyl ester. Lowry, Desch, and Southgate. *Trans.*, **97**, 899 (1910).
- Camphoric acid. Hartley. *Trans.*, **39**, 153 (1881).  
 " " Scheiber and Knothe. *Ber.*, **45**, 2252 (1912).  
 " " Baly, Marsden, and Stewart. *Trans.*, **89**, 966 (1906).  
 " " Purvis. *Trans.*, **107**, 643 (1915).
- Camphorquinone. Stewart and Baly. *Trans.*, **89**, 489 (1906).
- Camphorquinone-*p*-bromophenylhydrazone. Baly, Tuck, Marsden, and Gazdar. *Trans.*, **91**, 1572 (1907).
- Camphorquinonediphenylhydrazone. Baly, Tuck, Marsden, and Gazdar. *Trans.*, **91**, 1572 (1907).
- $\alpha$ -Camphorquinonehydrazone. Lankshear and Lapworth. *Trans.*, **99**, 1785 (1911).
- $\beta$ -Camphorquinonehydrazone. Lankshear and Lapworth. *Trans.*, **99**, 1785 (1911).
- Camphorquinonephenylbenzylhydrazone. Baly, Tuck, Marsden, and Gazdar. *Trans.*, **91**, 1572 (1907).
- $\alpha$ -Camphorquinonephenylcarbamyhydrazone. Lankshear and Lapworth. *Trans.*, **99**, 1785 (1911).
- $\beta$ -Camphorquinonephenylcarbamyhydrazone. Lankshear and Lapworth. *Trans.*, **99**, 1785 (1911).
- $\alpha$ -Camphorquinonephenylhydrazone. Baly, Tuck, Marsden, and Gazdar. *Trans.*, **91**, 1572 (1907).  
 " " Lankshear and Lapworth. *Trans.*, **99**, 1785 (1911).
- $\beta$ -Camphorquinonephenylhydrazone. Lankshear and Lapworth. *Trans.*, **99**, 1785 (1911).
- Camphorquinonephenylmethylhydrazone. Baly, Tuck, Marsden, and Gazdar. *Trans.*, **91**, 1572 (1907).
- $\alpha$ -Camphorquinonesemicarbazone. Lankshear and Lapworth. *Trans.*, **99**, 1785 (1911).
- $\beta$ -Camphorquinonesemicarbazone. Lankshear and Lapworth. *Trans.*, **99**, 1785 (1911).
- Camphor- $\beta$ -sulphonamide. Lowry and Desch. *Trans.*, **95**, 1340 (1909).
- Camphor- $\beta$ -sulphonanilide. Lowry and Desch. *Trans.*, **95**, 1340 (1909).
- Camphoryl chloride. Scheiber and Knothe. *Ber.*, **45**, 2252 (1912).
- Cane sugar. Soret. *Arch. des Sciences*, **10**, 429 (1883).  
 " " Hartley. *Trans.*, **51**, 58 (1887).  
 " " Lyman. *Astrophys. Journ.*, **25**, 45 (1907).
- Caprylene. Stark, Steubing, Enklaar, and Lipp. *Jahrb. Radioak.*, **10**, 139 (1913).
- o*-Carbamyphenoxyacetic acid. Merriman. *Trans.*, **103**, 1838 (1913).
- Carbon tetrachloride. Hartley. *Trans.*, **39**, 153 (1881).  
 " " Liveing and Dewar. *Proc. Roy. Soc.*, **35**, 71 (1883).
- Carbostyryl. Hartley and Dobbie. *Trans.*, **75**, 640 (1899).
- Carvenone. Crymble, Stewart, Wright, and Rea. *Trans.*, **99**, 1262 (1911).
- o*-Carboxyphenoxyacetic acid, ethyl ester, monoamide. Merriman. *Trans.*, **103**, 1838 (1913).
- Caryophyllene. Hantzsch. *Ber.*, **45**, 553 (1912).
- Catechol. Hartley. *Trans.*, **53**, 641 (1888).  
 " " Magini. *Atti R. Accad. Lincei*, **12**, ii, 87 (1903); *J. Chim. phys.*, **2**, 410 (1904).  
 " " Baly and Ewbank. *Trans.*, **87**, 1347 (1905).  
 " " Purvis and McClelland. *Trans.*, **103**, 1088 (1913).
- Cedar-wood oil. Pflüger. *Phys. Zeit.*, **10**, 405 (1909).
- Cephaeline. Dobbie and Fox. *Trans.*, **105**, 1639 (1914).
- Cetyl alcohol. Massol and Faucon. *Bull. Soc. Chim.*, **11**, 931 (1912).
- Cevadine. Hartley. *Phil. Trans.*, **176**, 471 (1885).
- Chelidonic acid, ethyl ester. Baly, Collie, and Watson. *Trans.*, **95**, 144 (1909).  
 " " sodium salts. Baly, Collie, and Watson. *Trans.*, **95**, 144 (1909).
- Chloral. Purvis and McClelland. *Trans.*, **101**, 1810 (1912).
- Chloral hydrate. Purvis and McClelland. *Trans.*, **101**, 1810 (1912).
- 4-Chloroacenaephthene. Purvis. *Trans.*, **101**, 1315 (1912).
- Chloroacetic acid. Hantzsch. *Zeit. phys. Chem.*, **86**, 624 (1914).  
 " " Wright. *Trans.*, **103**, 528 (1913).  
 " " sodium salt. Wright. *Trans.*, **103**, 528 (1913).

- Chloroacetone. Purvis and McClelland. Trans., **101**, 1810 (1912).  
*m*-Chloroaniline. Baly and Ewbank. Trans., **87**, 1355 (1905).  
 ,, Purvis and McClelland. Trans., **103**, 1088 (1913).  
 ,, Purvis. Trans., **103**, 1638 (1913).  
*o*-Chloroaniline. Baly and Ewbank. Trans., **87**, 1355 (1905).  
 ,, Purvis and McClelland. Trans., **103**, 1088 (1913).  
 ,, Purvis. Trans., **103**, 1638 (1913).  
*p*-Chloroaniline. Baly and Ewbank. Trans., **87**, 1355 (1905).  
 ,, Purvis and McClelland. Trans., **103**, 1088 (1913).  
 ,, Purvis. Trans., **103**, 1638 (1913).  
*m*-Chlorobenzaldehyde. Purvis. Trans., **105**, 2482 (1914).  
*o*-Chlorobenzaldehyde. ,, ,, ,, ,, ,,  
*p*-Chlorobenzaldehyde. ,, ,, ,, ,, ,,  
 Chlorobenzene. Pauer. Ann. der Phys., **61**, 363 (1897).  
 ,, Baly and Collie. Trans., **87**, 1332 (1905).  
 ,, Grebe. Zeit. wiss. Phot., **3**, 376 (1905).  
 ,, Ley and v. Engelhardt. Zeit. phys. Chem., **74**, 1 (1910).  
 ,, Baly. Trans., **99**, 856 (1911).  
 ,, Purvis. Trans., **99**, 811 (1911).  
 ,, Baly and Tryhorn. Trans., **107**, 1058 (1915).  
 ,, Witte. Zeit. wiss. Phot., **14**, 347 (1915).  
*p*-Chlorobenzenediazocyanide. Dobbie and Tinkler. Trans., **87**, 273 (1905).  
*o*-Chlorobenzene-*anti*-diazosulphonic acid, salts of. Hantzsch and Lifschitz. Ber., **45**, 3011 (1912).  
*o*-Chlorobenzene-*syn*-diazosulphonic acid, salts of. Hantzsch and Lifschitz. Ber., **45**, 3011 (1912).  
*m*-Chlorobenzoic acid. Scheiber. Ber., **45**, 2398 (1912).  
 ,, Purvis. Trans., **107**, 966 (1915).  
*o*-Chlorobenzoic acid. Scheiber. Ber., **45**, 2398 (1912).  
 ,, Purvis. Trans., **107**, 966 (1915).  
*p*-Chlorobenzoic acid. Purvis. Trans., **107**, 966 (1915).  
 Chlorobenzoquinone. Stewart and Baly. Trans., **89**, 618 (1906).  
*o*-Chlorobromobenzene. Purvis. Trans., **107**, 496 (1915).  
*m*-Chlorobromobenzene. Purvis. Trans., **107**, 496 (1915).  
*p*-Chlorobromobenzene. Purvis. Trans., **107**, 496 (1915).  
*aa'*-Chlorobromocamphor. Lowry and Desch. Trans., **95**, 807 (1909).  
*α*-Chlorocamphor. Lowry and Desch. Trans., **95**, 807, 1340 (1909).  
*α*-Chlorocamphor-*β*-sulphonic acid, potassium salt. Lowry and Desch. Trans., **95**, 1340 (1909).  
*β*-Chlorocrotonic acid. Macbeth, Stewart, and Wright. Trans., **101**, 599 (1912).  
 ,, Hantzsch and Scharf. Ber., **46**, 3570 (1913).  
*β*-Chloroisocrotonic acid. Macbeth, Stewart, and Wright. Trans., **101**, 599 (1912).  
 Chloroform. Hartley. Trans., **39**, 153 (1881).  
 3-Chloro-4-hydroxybenzeneazofornamide. Heilbron and Henderson. Trans., **103**, 1404 (1913).  
 1-Chloro-6-hydroxynaphthacenequinone. Baly and Tuck. Trans., **91**, 426 (1907).  
*α*-Chloronaphthalene. Purvis. Trans., **101**, 1315 (1912).  
*β*-Chloronaphthalene. Purvis. Trans., **101**, 1315 (1912).  
*aa'*-Chloronitrocarnphor. Lowry and Desch. Trans., **95**, 807 (1909).  
*m*-Chlorophenol. Purvis and McClelland. Trans., **103**, 1088 (1913).  
*o*-Chlorophenol. Ley and v. Engelhardt. Zeit. phys. Chem., **74**, 1 (1910).  
 ,, Purvis and McClelland. Trans., **103**, 1088 (1913).  
*p*-Chlorophenol. Purvis and McClelland. Trans., **103**, 1088 (1913).  
 Chlorophyll. van Gulik. Ann. der Phys., **23**, 277 (1907), and **46**, 147 (1915).  
*m*-Chlorotoluene. Baly and Ewbank. Trans., **87**, 1355 (1905).  
 ,, Baly. Trans., **99**, 856 (1911).  
 ,, Purvis. Trans., **99**, 1699 (1911).  
*o*-Chlorotoluene. Baly and Ewbank. Trans., **87**, 1355 (1905).  
 ,, Baly. Trans., **99**, 856 (1911).  
 ,, Purvis. Trans., **99**, 1699 (1911).  
*p*-Chlorotoluene. Baly and Ewbank. Trans., **87**, 1355 (1905).  
 ,, Baly. Trans., **99**, 856 (1911).  
 ,, Purvis. Trans., **99**, 1699 (1911).

- Chlorotoluquinoneoxime. Hantzsch. Ber., **43**, 1651 (1910).  
 Chrysene. Baly and Tuck. Trans., **93**, 1902 (1908).  
 Chrysoidine. Hartley. Trans., **51**, 152 (1887).  
 Cinchonidine. Hartley. Phil. Trans., **176**, 471 (1885).  
 Cinchonine. Hartley. Phil. Trans., **176**, 471 (1885).  
 „ Dobbie and Lauder. Trans., **83**, 605 (1903).  
 „ Hartley, Dobbie, and Lauder. Brit. Ass. Report, 1903, 126.  
 „ Dobbie and Lauder. Trans., **99**, 1254 (1911).  
 Cineol. Hantzsch. Ber., **45**, 553 (1912).  
 Cinnamaldehyde. Purvis. Trans., **105**, 2482 (1914).  
 Cinnamic acid. Stewart. Trans., **91**, 199 (1907).  
 „ „ Baly and Schaefer. Trans., **93**, 1808 (1908).  
 „ „ Ley and v. Engelhardt. Zeit. phys. Chem., **74**, 1 (1910).  
 „ „ Stobbe. Ber., **43**, 504 (1910); **44**, 960 (1911).  
 „ „ Crymble, Stewart, Wright, and Glendinning. Trans., **99**, 451 (1911).  
 „ „ Stobbe and Ebert. Ber., **44**, 1289 (1911).  
 „ „ Purvis. Trans., **107**, 966 (1915).  
 „ „ ethyl ester. Baly and Schaefer. Trans., **93**, 1808 (1908).  
 „ „ „ Baly and Tryhorn. Trans., **107**, 1058 (1915).  
 „ „ sodium salt. Wright. Trans., **103**, 528 (1913).  
 Cinnamylideneacetone. Baly and Schaefer. Trans., **93**, 1808 (1908).  
 Cinnamylideneacetophenone. Stobbe. Ber., **44**, 960 (1911).  
 Cinnamylideneacrylic acid. Baly and Schaefer. Trans., **93**, 1808 (1908).  
 Cinnamylidenemalonic acid. Baly and Schaefer. Trans., **93**, 1808 (1908).  
 „ „ Stobbe. Ber., **44**, 960 (1911).  
 „ „ methyl ester. Baly and Schaefer. Trans., **93**, 1808 (1908).  
 Cinnamylidene-*p*-toluidine. Tinkler. Trans., **103**, 885 (1913).  
 Citraconic acid. Stewart. Trans., **91**, 199 (1907).  
 „ „ Bielecki and Henri. Ber., **46**, 2596 (1913); Compt. rend., **157**,  
 372 (1913).  
 Citral. Purvis and McClelland. Trans., **103**, 433 (1913).  
 „ Bielecki and Henri. Ber., **47**, 1690 (1914); Compt. rend., **158**, 567 (1914).  
 Citrazinic acid, ethyl ester. Baker and Baly. Trans., **91**, 1122 (1907).  
 „ „ sodium salt. Baker and Baly. Trans., **91**, 1122 (1907).  
 Citric acid. Bielecki and Henri. Ber., **46**, 2596 (1913).  
 Cocaine. Dobbie and Fox. Trans., **103**, 1193 (1913).  
 „ Gompel and Henri. Compt. rend., **156**, 1541 (1913).  
 Codeine. Hartley. Phil. Trans., **176**, 471 (1885).  
 „ Gompel and Henri. Compt. rend., **157**, 1422 (1913).  
 Collidinedicarboxylic acid, ethyl ester. Ley and v. Engelhardt. Zeit. phys. Chem.,  
**74**, 1 (1910).  
 Congo-red. Hantzsch. Ber., **48**, 158 (1915).  
 Coniine. Purvis. Trans., **97**, 1035 (1910).  
 Corybulbine. Dobbie and Lauder. Trans., **83**, 605 (1903).  
 „ Hartley, Dobbie, and Lauder. Brit. Ass. Report, 1903, 126.  
 Corydaldine. Dobbie and Lauder. Trans., **83**, 605 (1903).  
 „ Hartley, Dobbie, and Lauder. Brit. Ass. Report, 1903, 126.  
 Corydaline. Dobbie and Lauder. Trans., **83**, 605 (1903).  
 „ Hartley, Dobbie, and Lauder. Brit. Ass. Report, 1903, 126.  
 „ Dobbie and Fox. Trans., **105**, 1639 (1914).  
 Corydic acid. Dobbie and Lauder. Trans., **83**, 605 (1903).  
 „ „ Hartley, Dobbie, and Lauder. Brit. Ass. Report, 1903, 126.  
 Cotarnine. Hartley. Phil. Trans., **176**, 471 (1885).  
 „ Dobbie, Lauder, and Tinkler. Trans., **83**, 598 (1903).  
 „ Hantzsch. Ber., **44**, 1783 (1911).  
 „ salts. Hantzsch. Ber., **43**, 1783 (1911).  
 Coumaranonecarboxylic acid, ethyl ester. Merriman. Trans., **103**, 1838 (1913).  
 „ „ „ acetyl derivative. Merriman. Trans., **103**,  
 1838 (1913).  
*o*-Coumaric acid. Baly, Tuck, and Marsden. Trans., **97**, 571 (1910).  
 „ „ sodium salt. Baly, Tuck, and Marsden. Trans., **97**, 571 (1910).  
 Creatinine. Hartley. Proc. Roy. Soc., **43**, 529 (1888).  
*m*-Cresol. Hartley. Trans., **53**, 641 (1888).

- m*-Cresol. Baly and Ewbank. Trans., **87**, 1347 (1905).  
 ,, Purvis and McClelland. Trans., **103**, 1088 (1913).  
 ,, methyl ether. Baly and Ewbank. Trans., **83**, 1347 (1905).  
*o*-Cresol. Hartley. Trans., **53**, 641 (1888).  
 ,, Baly and Ewbank. Trans., **87**, 1347 (1905).  
 ,, Purvis and McClelland. Trans., **103**, 1088 (1913).  
 ,, Wright. Trans., **105**, 669 (1914).  
 ,, methyl ether. Baly and Ewbank. Trans., **87**, 1347 (1905).  
*p*-Cresol. Hartley. Trans., **53**, 641 (1888).  
 ,, Baly and Ewbank. Trans., **87**, 1347 (1905).  
 ,, Purvis and McClelland. Trans., **103**, 1088 (1913).  
 ,, Wright. Trans., **105**, 669 (1914).  
 Crocein scarlet. Hartley. Trans., **51**, 153 (1887).  
 Crotonaldehyde. Purvis and McClelland. Trans., **103**, 433 (1913).  
 Crotonic acid. Stewart. Trans., **91**, 199 (1907).  
 ,, ,, Purvis and McClelland. Trans., **103**, 433 (1913).  
 ,, ,, Bielecki and Henri. Compt. rend., **157**, 372 (1913).  
 ,, ,, ,, ,, Ber., **46**, 2596, 3627 (1913), **47**, 1690 (1914).  
 ,, ,, Hantzsch and Scharf. Ber., **46**, 3570 (1913).  
 ,, ,, ethyl ester. Hantzsch and Scharf. Ber., **46**, 3570 (1913).  
 Cryptopine. Dobbie and Fox. Trans., **105**, 1639 (1914).  
 Crystal ponceau. van der Plaats. Ann. der Phys., **47**, 429 (1915).  
 Crystal violet. van der Plaats. Ann. der Phys., **47**, 429 (1915).  
 ,, ,, Schlenk and Marcus. Ber., **47**, 1664 (1914).  
 Cumeneazo- $\beta$ -naphtholdisulphonic acid. Hartley. Trans., **51**, 152 (1887).  
 $\gamma$ -Cumenediazonium sulphate. Hantzsch and Lifschitz. Ber., **45**, 3011 (1912).  
 Cuminaldehyde. Purvis. Trans., **105**, 2482 (1914).  
 Cuminolphenylhydrazone. Stobbe and Nowak. Ber., **46**, 2887 (1913).  
 Cupreine. Dobbie and Lauder. Trans., **83**, 605 (1903).  
 ,, Dobbie and Fox. Trans., **101**, 77 (1912).  
 Cyanic acid, potassium salt. Hartley, Dobbie, and Lauder. Trans., **79**, 848 (1901).  
*iso*Cyanic acid, ethyl ester. Hartley, Dobbie, and Lauder. Trans., **78**, 848 (1901).  
 ,, methyl ester. Hartley, Dobbie, and Lauder. Trans., **79**, 848 (1901).  
 Cyanoacetic acid, ethyl ester. Brannigan, Macbeth, and Stewart. Trans., **103**, 406 (1913).  
*m*-Cyanobenzoic acid. Scheiber. Ber., **45**, 2398 (1912).  
*o*-Cyanobenzoic acid. Scheiber. Ber., **45**, 2398 (1912).  
 ,, methyl ester. Scheiber. Ber., **45**, 2398 (1912).  
 Cyanuric acid. Hartley and Huntington. Proc. Roy. Soc., **31**, 1 (1880).  
 ,, ,, Hartley. Trans., **41**, 45 (1882).  
 ,, ,, Hartley, Dobbie, and Lauder. Trans., **79**, 848 (1901).  
 ,, ,, ethyl ester. Crymble, Stewart, Wright, and Rea. Trans., **99**, 1262 (1911).  
*iso*Cyanuric acid, ethyl ester. Crymble, Stewart, Wright, and Rea. Trans., **99**, 1262 (1911).  
 ,, ,, methyl ester. Hartley, Dobbie, and Lauder. Trans., **79**, 848 (1901).  
 Cyanuric chloride. Hartley, Dobbie, and Lauder. Trans., **79**, 848 (1901).  
 $\Delta^{1,2}$ -Cyclohexadiene. Stark and Levy. Jahrb. Radioak., **10**, 179 (1913).  
 ,, Stark and Lipp. Zeit. phys. Chem., **86**, 36 (1914).  
 Cyclohexanone. Henderson, Henderson, and Heilbron. Ber., **47**, 876 (1914).  
 ,, Bielecki and Henri. Ber., **47**, 1690 (1914).  
 Cyclohexene. Stark and Levy. Jahrb. Radioak., **10**, 179 (1913).  
 Cymene. Hartley and Huntington. Phil. Trans., **170**, I. 257 (1879).  
 ,, Hartley. Phil. Trans., **203** A, 475 (1908); Zeit. wiss. Phot., **6**, 299 (1908).  
 ,, Hantzsch. Ber., **45**, 553 (1912).  
 Cymeneazo- $\beta$ -naphthalenedisulphonic acid. Hartley. Trans., **51**, 152 (1887).

## D

- Dehydracetic acid. Baly, Collie, and Watson. Trans., **95**, 144 (1909).  
*iso*Dehydracetic acid. Baly, Collie, and Watson. Trans., **95**, 144 (1909).  
 Dehydrocorydaline. Dobbie and Lauder. Trans., **83**, 605 (1903).  
 ,, Hartley, Dobbie, and Lauder. Brit. Ass. Report, 1903, 126.





- Dibromothymoquinone. Stewart and Baly. Trans., **89**, 618 (1906).
- 2·4-Dichloroaniline. Purvis. Trans., **103**, 1638 (1913).
- m*-Dichlorobenzene. Baly and Ewbank. Trans., **87**, 1355 (1905).  
 Baly. Trans., **99**, 856 (1911).  
 Purvis. Trans., **99**, 1699 (1911).
- o*-Dichlorobenzene. Baly and Ewbank. Trans., **87**, 1355 (1905).  
 Baly. Trans., **99**, 856 (1911).  
 Purvis. Trans., **99**, 1699 (1911).
- p*-Dichlorobenzene. Baly and Ewbank. Trans., **87**, 1355 (1905).  
 Baly. Trans., **99**, 856 (1911).  
 Purvis. Trans., **107**, 496 (1915).
- Dichlorobenzoinquinone. Stewart and Baly. Trans., **89**, 618 (1906).
- p*-Dichlorodioxytterephthalic acid. Hantzsch. Ber., **48**, 797 (1915).  
 ethyl ester. Hantzsch. Ann., **384**, 135 (1911).
- 3·5-Dichloro-4-hydroxybenzeneazofornamide. Heilbron and Henderson. Trans., **103**, 1404 (1913).
- Dichlorophenylphenazonium chloride. Balls, Hewitt, and Newman. Trans., **101**, 1840 (1912).
- 3·5-Dichloropyridine. Purvis. Trans., **103**, 2283 (1913).
- Dichlorothymoquinone. Stewart and Baly. Trans., **89**, 618 (1906).
- 5·7-Diethoxy-2-*mp*-diethoxyphenyl-4-ethyl-1·4-benzopyranol anhydrohydrochloride. Watson, Sen, and Medhi. Trans., **107**, 1477 (1915).
- 5·7-Diethoxy-2-*p*-ethoxyphenyl-4-ethyl-1·4-benzopyranol anhydrohydriodide. Watson, Sen, and Medhi. Trans., **107**, 1477 (1915).
- Diethyl camphorcarboxylate. Lowry, Desch, and Southgate. Trans., **97**, 899 (1910).
- Diethyl collidinedicarboxylate. Ley and v. Engelhardt. Zeit. phys. Chem., **74**, 1 (1910).
- Diethyl diethylmalonate. Brannigan, Macbeth, and Stewart. Trans., **103**, 406 (1913).
- Diethyl diethylxaloacetate. Hantzsch. Ber., **48**, 1407 (1915).
- Diethyl dimethylxaloacetate. " " " " " " " " " " " "
- Diethyl ketone. Bielecki and Henri. Compt. rend., **155**, 456 (1912).  
 Purvis and McClelland. Trans., **101**, 1810 (1912).  
 Bielecki and Henri. Ber., **45**, 2819 (1912); **46**, 3627 (1913).  
 Compt. rend., **156**, 1322 (1913).  
 Rice. Proc. Roy. Soc., **91 A**, 76 (1914).
- Diethyl ketone phenylhydrazone. Baly and Tuck. Trans., **89**, 982 (1906).
- Diethyl ketone phenylmethylhydrazone. Baly and Tuck. Trans., **89**, 982 (1906).
- Diethylamine. Hartley and Huntington. Phil. Trans., **170**, I. 257 (1879).  
 Bielecki and Henri. Compt. rend., **156**, 1860 (1913).
- Diethylaniline. Purvis. Trans., **97**, 1546 (1910).
- Diethyl-2·4-dinitroaniline. Hantzsch. Ber., **43**, 1662 (1910).
- Diethyl-3·4-dinitroaniline. Hantzsch. Ber., **43**, 1662 (1910).
- Diethylmalonic acid, ethyl ester. Brannigan, Macbeth, and Stewart. Trans., **103**, 406 (1913).
- Diethylnitrosoamine. Baly and Desch. Trans., **93**, 1747 (1908).
- Digitaline. Hartley. Phil. Trans., **176**, 471 (1885).
- Dihydroanthracene. Baly and Tuck. Trans., **93**, 1902 (1908).  
 Stevenson. J. phys. Chem. **15**, 845 (1911).
- 1·3-Dihydrobenzene. Zelinsky and Gorsky. Ber., **44**, 2312 (1911).
- 1·4-Dihydrobenzene. Zelinsky and Gorsky. Ber., **44**, 2312 (1911).
- Dihydrocarvone. Crymble, Stewart, Wright, and Rea. Trans., **99**, 1262 (1911).
- Dihydrocollidinedicarboxylic acid, ethyl ester. Baker and Baly. Trans., **91**, 1122 (1907).  
 Ley and v. Engelhardt. Zeit. phys. Chem., **74**, 1 (1910).
- 1·4-Dihydronaphthalene. Baly and Tuck. Trans., **93**, 1902 (1908).  
 Leonard. Trans., **97**, 1246 (1910).
- Dihydrophenylacridine. Dobbie and Tinkler. Trans., **87**, 269 (1905).
- 1·2-Dihydroxyanthraquinone. Meek and Watson. Trans., **109**, 544 (1916).
- 1·4-Dihydroxyanthraquinone. Meek and Watson. Trans., **109**, 544 (1916).
- 5·7-Dihydroxy-2-*mp*-dihydroxyphenyl-4-ethyl-1·4-benzopyranol anhydride and anhydrohydriodide. Watson, Sen, and Medhi. Trans., **107**, 1477 (1915).

- Dihydroxyfluorescein. Medhi and Watson. *Trans.*, **107**, 1579 (1915).
- 5-7-Dihydroxy-2-*p*-hydroxyphenyl-4-ethyl-1'-4-benzopyranol anhydride and anhydrohydriodide. Watson, Sen, and Medhi. *Trans.*, **107**, 1477 (1915).
- 1-6-Dihydroxynaphthacenequinone. Baly and Tuck. *Trans.*, **91**, 426 (1907).
- 1-7(10)-Dihydroxynaphthacenequinone. Baly and Tuck. *Trans.*, **91**, 426 (1907).
- 1-8 (9)-Dihydroxynaphthacenequinone. Baly and Tuck. *Trans.*, **91**, 426 (1907).
- 1-5-Dihydroxynaphthacenequinonesulphonic acid. Baly and Tuck. *Trans.*, **91**, 426 (1907).
- m*-Diiodobenzene. Purvis. *Trans.*, **99**, 2318 (1911).
- o*-Diiodobenzene. Purvis. *Trans.*, **99**, 2318 (1911).
- 1-2-Diketo-5-acetyl-3-phenyl-4-methyl- $\Delta^3$ -cyclopentene. Purvis. *Trans.*, **99**, 107 (1911).
- ” ” ” ” ” oxime. Purvis. *Trans.*, **99**, 107 (1911).
- ” ” ” ” ” phenylhydrazone. Purvis. *Trans.*, **99**, 107 (1911).
- 1-3-Diketo-2-anisylidenehydrindamine. Purvis. *Trans.*, **99**, 1953 (1911).
- 1-3-Diketo-2-benzylidenehydrindamine. Purvis. *Trans.*, **99**, 1953 (1911).
- Diketobutyric acid, ethyl ester. Bielecki and Henri. *Compt. rend.*, **158**, 1022 (1914).
- 1-3-Diketo-2-*p*-dimethylaminobenzylidenehydrindamine. Purvis. *Trans.*, **99**, 1953 (1911).
- 2-3-Diketo-4-5-diphenylpyrroline. Purvis. *Trans.*, **97**, 2533 (1910).
- ” phenylhydrazone. Purvis. *Trans.*, **97**, 2535 (1910).
- 1-4-Diketo hexamethylene. Hartley and Dobbie. *Trans.*, **73**, 598 (1898).
- Diketohydrindylidenediketohydrindamine. Purvis. *Trans.*, **99**, 1953 (1911).
- 2-3-Diketo-4-phenyl-5-*p*-anisylpyrroline. Purvis. *Trans.*, **97**, 2535 (1910).
- 2-3-Diketo-4-phenyl-5-*p*-cumylpyrroline. Purvis. *Trans.*, **97**, 2535 (1910).
- 2-3-Diketo-4-phenyl-5-piperonylpyrroline. Purvis. *Trans.*, **97**, 2535 (1910).
- 2-3-Diketo-4-phenyl-5-*m*-tolylpyrroline. Purvis. *Trans.*, **97**, 2535 (1910).
- 2-3-Diketo-4-phenyl-5-*o*-tolylpyrroline. Purvis. *Trans.*, **97**, 2535 (1910).
- 2-3-Diketo-4-phenyl-5-*p*-tolylpyrroline. Purvis. *Trans.*, **97**, 2535 (1910).
- 2-3-Diketo-4-phenyl-5-*p*-tolylpyrrolinephenylhydrazone. Purvis. *Trans.*, **97**, 2535 (1910).
- pp'*-Dimethoxy-2-5-diphenylpyrazine. Tutin and Caton. *Trans.*, **97**, 2535 (1910).
- pp'*-Dimethoxy-2-6-diphenylpyrazine. Tutin and Caton. *Trans.*, **97**, 2524 (1910).
- 6-7-Dimethoxy-2-methyl-3'-4-dihydroisoquinolinium chloride. Tinkler. *Trans.*, **101**, 1245 (1912).
- 6-7-Dimethoxy-2-methyltetrahydroisoquinoline. Tinkler. *Trans.*, **101**, 1245 (1912).
- 6-7-Dimethoxyisoquinoline-1-carboxylic acid. Dobbie and Fox. *Trans.*, **105**, 1639 (1914).
- Dimethyl camphorcarboxylate. Lowry, Desch, and Southgate. *Trans.*, **97**, 899 (1910).
- Dimethyl oxaloacetate. Hantzsch. *Ber.*, **48**, 1407 (1915).
- Dimethyl terephthalate. Hartley and Hedley. *Trans.*, **91**, 314 (1907).
- Dimethylamine. Hartley and Huntington. *Phil. Trans.*, **170**, I. 257 (1879).
- ” Bielecki and Henri. *Compt. rend.*, **156**, 1860 (1913).
- p*-Dimethylaminoazobenzene. Tuck. *Trans.*, **95**, 1809 (1909).
- ” Hantzsch. *Ber.*, **42**, 2129 (1909); **46**, 1537 (1913).
- ” Baly and Hampson. *Trans.*, **107**, 248 (1915).
- ” Hantzsch. *Ber.*, **48**, 167 (1915).
- p*-Dimethylaminoazobenzonic acid, ethyl ester. Hantzsch. *Ber.*, **46**, 1537 (1913).
- p*-Dimethylaminobenzaldehyde. Baly and Marsden. *Trans.*, **93**, 2108 (1908).
- ” Purvis. *Trans.*, **103**, 1638 (1913).
- Dimethylaminobenzeneazoaniline. Hantzsch. *Ber.*, **46**, 1537 (1913).
- Dimethylaminobenzeneazoanisole. Hantzsch. *Ber.*, **46**, 1537 (1913).
- p*-Dimethylaminobenzeneazophenol. Hewitt and Thomas. *Trans.*, **95**, 1292 (1909).
- m*-Dimethylaminophenol. Purvis. *Trans.*, **103**, 1638 (1913).
- Dimethylaniline. Baly and Collie. *Trans.*, **87**, 1332 (1905).
- ” Ley and v. Engelhardt. *Zeit. phys. Chem.*, **74**, 1 (1910).
- ” Purvis. *Trans.*, **97**, 1546 (1910).
- Dimethylanthranilic acid. Ley and Ulrich. *Ber.*, **42**, 3440 (1909).
- ” ” methyl ester. Ley and Ulrich. *Ber.*, **42**, 3440 (1909).

- Dimethylbenziminazolium iodide. Tinkler. Trans., **101**, 1245 (1912).  
 Dimethylbenziminazolol. Tinkler. Trans., **101**, 1245 (1912).  
 $\alpha$ -Dimethylbutadiene. Stark, Steubing, Enklaar, and Lipp. Jahrb. Radioak., **10**, 139 (1913).  
 $\beta$ -Dimethylbutadiene. Stark, Steubing, Enklaar, and Lipp. Jahrb. Radioak., **10**, 139 (1913).  
 Dimethyldihydroisoquinoline. Tinkler. Trans., **101**, 1245 (1912).  
 Dimethyldihydroresorcin. Baly and Ewbank. Trans., **87**, 1347 (1905).  
 Dimethyl-2,4-dinitroaniline. Hantzsch. Ber., **43**, 1662 (1910).  
 Dimethyl-3,4-dinitroaniline. Hantzsch. Ber., **43**, 1662 (1910).  
 Dimethylfulvene. Stark, Steubing, Enklaar, and Lipp. Jahrb. Radioak., **10**, 139 (1913).  
 Dimethylnitrobarbituric acid. Hantzsch and Voigt. Ber., **45**, 85 (1912).  
 Dimethylnitrosoamine. Baly and Desch. Trans., **93**, 1747 (1908).  
 3,3'-Dimethylphenazothionium chloride. Eckert and Pummerer. Zeit. phys. Chem., **87**, 599 (1914).  
 3,6-Dimethylphenazothionium chloride. Eckert and Pummerer. Zeit. phys. Chem., **87**, 599 (1914).  
 " " Pummerer, Eckert, and Gassner. Ber., **47**, 1494 (1914).  
 2-Dimethylpiperazine. Purvis. Trans., **103**, 2283 (1913).  
 3-Dimethylpiperazine. Purvis. Trans., **103**, 2283 (1913).  
 2,5-Dimethylpyrazine. Hartley and Dobbie. Trans., **77**, 846 (1900).  
 Dimethylpyrone. Baly, Collie, and Watson. Trans., **95**, 144 (1909).  
 Dimethylpyronecarboxylic acid. Baly, Collie, and Watson. Trans., **95**, 144 (1909).  
*o*-Dimethyltoluidine. Ley and v. Engelhardt. Zeit. phys. Chem., **74**, 1 (1910).  
 Dimethyl-*o*-toluidineazobenzenesulphonic acid. Hantzsch. Ber., **48**, 167 (1915).  
 Dimethylvioluric acid. Hantzsch and Robison. Ber., **43**, 45 (1910).  
 " " salts. Hantzsch and Robison. Ber., **43**, 45 (1910).  
 Dinaphthantracene. Homer and Purvis. Trans., **93**, 1319 (1908); **97**, 1155 (1910).  
 $\beta\beta$ -Dinaphthyl. Homer and Purvis. Trans., **93**, 1319 (1908).  
 3,5-Dinitroacetyl-*p*-aminophenol. Meldola and Hollely. Trans., **105**, 410 (1914).  
 2,6-Dinitro-4-aminoanisole. Meldola and Hewitt. Trans., **103**, 876 (1913).  
 1,3-Dinitro-5-aminobenzene. Hantzsch. Ber., **43**, 1662 (1910).  
 4,6-Dinitro-3-aminophenol. Morgan, Moss, and Porter. Trans., **107**, 1296 (1915).  
 3,5-Dinitro-4-amino-*o*-xylene. Morgan, Jobling, and Barnett. Trans., **101**, 1209 (1912).  
 " " Morgan, Moss, and Porter. Trans., **107**, 1296 (1915).  
 3,4-Dinitro-5-amino-*o*-xylene. Morgan, Jobling, and Barnett. Trans., **101**, 1209 (1912).  
 5,6-Dinitro-3-amino-*o*-xylene. Morgan, Jobling, and Barnett. Trans., **101**, 1209 (1912).  
 4,5-Dinitro-3-amino-*o*-xylene. Morgan, Jobling, and Barnett. Trans., **101**, 1209 (1912).  
 3,5-Dinitro-6-amino-*o*-xylene. Morgan, Jobling, and Barnett. Trans., **101**, 1209 (1912).  
 " " Morgan, Moss, and Porter. Trans., **107**, 1296 (1915).  
 2,4-Dinitroaniline. Morgan, Moss, and Porter. Trans., **107**, 1296 (1915).  
 3,5-Dinitro-4-anilino-*o*-xylene. Morgan, Moss, and Porter. Trans., **107**, 1296 (1915).  
 3,5-Dinitro-6-anilino-*o*-xylene. Morgan, Moss, and Porter. Trans., **107**, 1296 (1915).  
 3,5-Dinitro-4-*o*-anisidino-*o*-xylene. Morgan, Moss, and Porter. Trans., **107**, 1296 (1915).  
 3,5-Dinitro-4-*p*-anisidino-*o*-xylene. Morgan, Moss, and Porter. Trans., **107**, 1296 (1915).  
 3,5-Dinitro-6-*o*-anisidino-*o*-xylene. Morgan, Moss, and Porter. Trans., **107**, 1296 (1915).  
 3,5-Dinitro-6-*p*-anisidino-*o*-xylene. Morgan, Moss, and Porter. Trans., **107**, 1296 (1915).  
*m*-Dinitrobenzene. Purvis and McClelland. Trans., **103**, 1088 (1913).  
*o*-Dinitrobenzene. Purvis and McClelland. Trans., **103**, 1088 (1913).  
*p*-Dinitrobenzene. Purvis and McClelland. Trans., **103**, 1088 (1913).  
 3,3'-Dinitrobenzidine. Cain, Macbeth, and Stewart. Trans., **103**, 586 (1913).  
 3,5'-Dinitrobenzidine. Cain, Macbeth, and Stewart. Trans., **103**, 586 (1913).

- 3·5-Dinitro-4-benzylamino-*o*-xylene. Morgan, Moss, and Porter. Trans., **107**, 1296 (1915).
- 3·5-Dinitro-6-benzylamino-*o*-xylene. Morgan, Moss, and Porter. Trans., **107**, 1296 (1915).
- 2·4-Dinitrobenzylaniline. Morgan, Moss, and Porter. Trans., **107**, 1296 (1915).
- m**p*-Dinitrodiazaminobenzene. Smith and Watts. Trans., **97**, 562 (1910).
- 3·5-Dinitro-4-dimethylamino-*o*-xylene. Morgan, Moss, and Porter. Trans., **107**, 1296 (1915).
- 3·5-Dinitro-6-dimethylamino-*o*-xylene. Morgan, Moss, and Porter. Trans., **107**, 1296 (1915).
- 2·4-Dinitrodimethylaniline. Morgan, Moss, and Porter. Trans., **107**, 1296 (1915).
- 2·5-Dinitrodimethyl-*p*-toluidine. Morgan and Clayton. Trans., **99**, 1941 (1911).
- 2·6-Dinitrodimethyl-*p*-toluidine. Morgan and Clayton. Trans., **99**, 1941 (1911).
- 3·5-Dinitrodimethyl-*p*-toluidine. Morgan and Clayton. Trans., **99**, 1941 (1911).
- 2·6-Dinitro-*p*-dimethyltoluidine. Morgan, Jobling, and Barnett. Trans., **101**, 1209 (1912).
- 3·5-Dinitro-*p*-dimethyltoluidine. Morgan, Jobling, and Barnett. Trans., **101**, 1209 (1912).
- Dinitroethane. Hedley. Ber., **41**, 1195 (1908).
- 3·5-Dinitro-4-ethylamino-*o*-xylene. Morgan, Moss, and Porter. Trans., **107**, 1296 (1915).
- 3·5-Dinitro-6-ethylamino-*o*-xylene. Morgan, Moss, and Porter. Trans., **107**, 1296 (1915).
- Dinitrofluorene. Baly, Tuck, and Marsden. Trans., **97**, 571 (1910).
- Dinitromethane. Hedley. Ber., **41**, 1195 (1908).
- „ Hantzsch and Voigt. Ber., **45**, 85 (1912).
- 3·5-Dinitro-4-methylamino-*o*-xylene. Morgan, Moss, and Porter. Trans., **107**, 1296 (1915).
- 3·5-Dinitro-6-methylamino-*o*-xylene. Morgan, Moss, and Porter. Trans., **107**, 1296 (1915).
- 2·4-Dinitromethylaniline. Morgan, Moss, and Porter. Trans., **107**, 1296 (1915).
- 3·5-Dinitromethyl-*p*-toluidine. Morgan and Clayton. Trans., **99**, 1941 (1911).
- „ Morgan, Jobling, and Barnett. Trans., **101**, 1209 (1912).
- 2·5-Dinitrophenetole. Buttle and Hewitt. Trans., **95**, 1755 (1909).
- 2·4-Dinitrophenol. Buttle and Hewitt. Trans., **95**, 1755 (1909).
- „ Bortini. Zeit. phys. Chem., **87**, 104 (1914).
- „ Wright. Trans., **105**, 669 (1914).
- 2·6-Dinitrophenol. Buttle and Hewitt. Trans., **95**, 1755 (1909).
- Dinitrophenylmalonic acid, ethyl ester. Hantzsch and Picton. Ber., **42**, 2119 (1909).
- 2·4-Dinitrophenylpiperidine. Morgan, Moss, and Porter. Trans., **107**, 1296 (1915).
- 3·5-Dinitro-4-piperidino-*o*-xylene. Morgan, Moss, and Porter. Trans., **107**, 1296 (1915).
- m*-Dinitrotolidines. Morgan, Moss, and Porter. Trans., **107**, 1296 (1915).
- o*-Dinitrotolidines. Morgan, Moss, and Porter. Trans., **107**, 1296 (1915).
- 2·6-Dinitro-*p*-toluidine. Morgan, Jobling, and Barnett. Trans., **101**, 1209 (1912).
- 3·5-Dinitro-*p*-toluidine. Morgan, Jobling, and Barnett. Trans., **101**, 1209 (1912).
- 3·5-Dinitro-3-*p*-toluidino-*o*-xylene. Morgan, Moss, and Porter. Trans., **107**, 1296 (1915).
- 4·6-Dinitro-3-*p*-toluidino-*o*-xylene. Morgan, Moss, and Porter. Trans., **107**, 1296 (1915).
- 3·5-Dinitro-*p*-tolylmethylnitroamin Morgan and Clayton. Trans., **99**, 1941 (1911),  
„ Morgan, Jobling, and Barnett. Trans., **101**, 1209 (1912).
- 2·5-Dinitro-*p*-tolylmethylnitrosoamin Morgan and Clayton. Trans., **99**, 1941 (1911).
- 3·5-Dinitro-*p*-tolylmethylnitrosoamine. Morgan and Clayton. Trans., **99**, 1941 (1911).
- „ Morgan, Jobling, and Barnett. Trans., **101**, 1209 (1912).
- 3·4-Dinitro-*o*-xylene. Baly, Tuck, and Marsden. Trans., **97**, 571 (1910).
- 3·5-Dinitro-*o*-xylene. Baly, Tuck, and Marsden. Trans., **97**, 571 (1910).
- 4·5-Dinitro-*o*-xylene. „ „ „ „ „ „ „ „

- 1:4-Dioxyanthraquinone. Meyer and Fischer. Ber., **46**, 85 (1913).  
 1:5-Dioxyanthraquinone. " " " " " " "  
 2:6-Dioxyanthraquinone. " " " " " " "  
 Dioxyterephthalic acid. Hantzsch. Ber., **48**, 797 (1915).  
*p*-Dioxytriphenylmethane. Meyer and Fischer. Ber., **46**, 70 (1913)  
 Dioxyfumaric acid. Hantzsch. Ber., **48**, 1407 (1915).  
 Dipentene. Hantzsch. Ber., **45**, 553 (1912).  
 Diphenyl. Baly and Tuck. Trans., **93**, 1902 (1908).  
 " Purvis. Trans., **105**, 590 (1914).  
 " Baly and Tryhorn. Trans., **107**, 1058 (1915).  
 Diphenyl disulphide. Fox and Pope. Trans., **103**, 1263 (1913).  
 Diphenyl ether. Purvis and McClelland. Trans., **101**, 1514 (1912).  
 " Purvis. Trans., **105**, 590 (1914).  
 Diphenyl phthalate. Purvis. Trans., **105**, 1372 (1914).  
 Diphenyl sulphide. Fox and Pope. Trans., **103**, 1263 (1913).  
 Diphenylamine. Baker. Trans., **91**, 1490 (1907).  
 " Purvis and McClelland. Trans., **101**, 1514 (1912).  
 " Purvis. Trans., **105**, 590 (1914).  
 Diphenylbutadiene. Stobbe and Ebert. Ber., **44**, 1289 (1911).  
 Diphenylbutane. Stobbe and Ebert. Ber., **44**, 1289 (1911).  
 Diphenylbutenine. Stobbe and Ebert. Ber., **44**, 1289 (1911).  
*o*s-Diphenylcarbamide. Purvis. Trans., **105**, 1372 (1914).  
*s*-Diphenylcarbamide. " " " " " " "  
 Diphenyldiacetylene. Stobbe and Ebert. Ber., **44**, 1289 (1911).  
 Diphenylene oxide. Dobbie, Fox, and Gauge. Trans., **103**, 36 (1913).  
 Diphenylmaleinimide. Ley and Fischer. Ber., **46**, 327 (1913).  
 Diphenylmethane. Baker. Trans., **91**, 1490 (1907).  
 " Purvis and McClelland. Trans., **101**, 1514 (1912).  
 " Purvis. Trans., **105**, 590 (1914).  
 " Baly and Tryhorn. Trans., **107**, 1058 (1915).  
 2:5-Diphenylpyrazine. Tutin and Clayton. Trans., **97**, 2524 (1910).  
 2:6-Diphenylpyrazine. " " " " " " "  
 4:5-Diphenylpyrrolinophenazine. Purvis. Trans., **97**, 2535 (1910).  
*s*-Diphenylthiocarbamide. Purvis. Trans., **105**, 1372 (1914).  
 Diphenylthiovioluric acid and salts. Lifschitz. Ber., **47**, 1068 (1914).  
 Diphenylvioluric acid. Hantzsch and Robison. Ber., **43**, 45 (1910).  
 " Lifschitz. Ber., **47**, 1068 (1914).  
 " salts. Hantzsch and Robison. Ber., **43**, 45 (1910).  
 " Lifschitz. Ber., **47**, 1068 (1914).  
 Dipropargyl. Stark and Lipp. Jahrb. Radioak., **10**, 175 (1913).  
 " Zeit. phys. Chem., **86**, 36 (1914).  
 Dipropyl ketone. Bielecki and Henri. Compt. rend., **156**, 1322 (1913); Ber., **46**,  
 3627 (1913).  
 " Henderson, Henderson, and Heilbron. Ber., **47**, 876 (1914).  
 " Rice. Proc. Roy. Soc., **91A**, 76 (1914).  
 Diisopropyl ketone. Rice. Proc. Roy. Soc., **91A**, 76 (1914).  
 Dipropylamine. Bielecki and Henri. Compt. rend., **156**, 1860 (1913).  
 2-Dipyridyl. Hartley. Trans., **47**, 685 (1885).  
 " Purvis. Trans., **103**, 2283 (1913).  
 Dithiocarbonic acid, ethyl ester. Purvis, Jones, and Tasker. Trans., **97**, 2287 (1910).  
 " phenyl ester. " " " " " " "  
 Dithiofluorane. Meyer and Fischer. Ber., **46**, 70 (1913).  
 Dithioxalic acid, ethyl ester. Purvis, Jones, and Tasker. Trans., **97**, 2287 (1910).  
 " phenyl ester. " " " " " " "  
 " propyl ester. " " " " " " "  
 Doebner's violet. Meyer and Fischer. Ber., **46**, 70 (1913).

## E

- Emetine. Dobbie and Fox. Trans., **105**, 1639 (1914).  
 Eosine. Meyer and Marx. Ber., **41**, 2446 (1908).  
 " Nichols and Merritt. Phys. Rev., **31**, 376 (1910).  
 " Massol and Faucon. Bull. Soc. Chim., **13**, 217 (1913).

- Erucic acid. Macbeth, Stewart, and Wright. *Trans.*, **101**, 599 (1912).
- iso*Erucic acid. Macbeth, Stewart, and Wright. *Trans.*, **101**, 599 (1912).
- Erythrooxyanthraquinone. Meyer and Fischer. *Ber.*, **46**, 85 (1913).
- Erythrosine. Massol and Faucon. *Bull. Soc. Chim.*, **13**, 217 (1913).
- „ van der Plaats. *Ann. der Phys.*, **47**, 429 (1915).
- Ethaneazobenzene. *See* Benzeneazoethane.
- Ethoxycaffeine. Hartley. *Trans.*, **87**, 1796 (1905).
- $\beta$ -Ethoxycrotonic acid. Hantzsch and Scharf. *Ber.*, **46**, 3570 (1913).
- „ „ ethyl ester. Baly and Desch. *Trans.*, **85**, 1029 (1904).
- „ „ „ „ Hantzsch. *Ber.*, **43**, 3049 (1910); **45**, 559 (1912).
- „ „ „ „ Hantzsch and Voigt. *Ber.*, **45**, 85 (1912).
- „ „ „ „ Hantzsch and Scharf. *Ber.*, **46**, 3570 (1913).
- „ „ „ „ Hantzsch. *Ber.*, **48**, 772 (1915).
- „ „ „ „ dibromide. Hantzsch. *Ber.*, **48**, 772 (1915).
- „ „ „ „ sodium salt. Hantzsch and Scharf. *Ber.*, **46**, 3570 (1913).
- 3-Ethoxy-1,1-dimethyl- $\Delta^3$ -cyclohexenylidene-5-cyanoacetic acid, ethyl ester. Crossley and Gilling. *Trans.*, **97**, 518 (1910).
- Ethoxyfumaric acid, ethyl ester. Baly and Desch. *Trans.*, **87**, 766 (1905).
- $\gamma$ -Ethoxylutidine. Baker and Baly. *Trans.*, **91**, 1122 (1907).
- Ethoxymethylenecamphor. Lowry and Southgate. *Trans.*, **97**, 905 (1910).
- 8-Ethoxyquinoline. Fox. *Trans.*, **97**, 1119 (1910).
- Ethyl acetate. Hartley and Huntington. *Phil. Trans.*, **170**, I, 257 (1879).
- „ „ Bielecki and Henri. *Compt. rend.*, **155**, 456, 1617 (1912); **156**, 550 (1913); *Ber.*, **45**, 2819 (1912); **46**, 1304 (1913).
- „ „ Henri and Wurmser. *Compt. rend.*, **156**, 230 (1913); *Jour. de Phys.*, **3**, 305 (1913).
- „ „ Hantzsch and Scharf. *Ber.*, **46**, 3570 (1913).
- Ethyl acetoacetate. Baly and Desch. *Trans.*, **85**, 1029 (1904); *Astrophys. Journ.*, **23**, 110 (1906).
- „ „ Stewart and Baly. *Trans.*, **89**, 489 (1906).
- „ „ Hantzsch. *Ber.*, **44**, 1771 (1911).
- „ „ Hantzsch and Voigt. *Ber.*, **45**, 85 (1912).
- „ „ Baly and Rice. *Trans.*, **103**, 91 (1913).
- „ „ Morgan and Reilly. *Trans.*, **103**, 1494 (1913).
- „ „ Bielecki and Henri. *Ber.*, **46**, 3267 (1913); *Compt. rend.*, **156** 1322 (1913); **158**, 866 (1914).
- „ „ Henderson, Henderson, and Heilbron. *Ber.*, **47**, 876 (1914).
- Ethyl acetonedicarboxylate. Baly and Desch. *Trans.*, **87**, 766 (1905).
- „ „ Bielecki and Henri. *Ber.*, **46**, 2596 (1913).
- Ethyl acetylenedicarboxylate. Bielecki and Henri. *Ber.*, **46**, 2596 (1913).
- Ethyl acetylglyoxalate. Bielecki and Henri. *Ber.*, **47**, 1690 (1914).
- Ethyl acetylsuccinate. Baly and Desch. *Trans.*, **87**, 766 (1905).
- Ethyl alcohol. Hartley and Huntington. *Phil. Trans.*, **170**, I, 257 (1879).
- „ „ Bielecki and Henri. *Compt. rend.*, **155**, 456 (1912); *Ber.*, **45**, 2819 (1912).
- „ „ Massol and Faucon. *Bull. Soc. Chim.*, **11**, 931 (1912).
- „ „ Henri. *Ber.*, **46**, 3650 (1913).
- Ethyl aminocrotonate. Baly and Desch. *Trans.*, **85**, 1029 (1904).
- Ethyl anilinoacetate. Ley and Ulrich. *Ber.*, **42**, 3440 (1909).
- Ethyl antipyrine-4-azoacetoacetate. Morgan and Reilly. *Trans.*, **103**, 1494 (1913).
- Ethyl benzoate. Baly and Tryhorn. *Trans.*, **107**, 1058 (1915).
- Ethyl benzoylacetate. Baly and Desch. *Trans.*, **87**, 766 (1905).
- Ethyl benzoylsuccinate. Baly and Desch. *Trans.*, **87**, 766 (1905); *Astrophys. Journ.*, **23**, 110 (1906).
- Ethyl bromonitromalonate. Hantzsch and Voigt. *Ber.*, **45**, 85 (1912).
- Ethyl *isobutyl* ketone. Rice. *Proc. Roy. Soc.*, **91A**, 76 (1914).
- Ethyl butyrate. Hartley and Huntington. *Phil. Trans.*, **170**, I, 257 (1879).
- „ „ Bielecki and Henri. *Compt. rend.*, **155**, 1617 (1912); **156**, 550 (1913); *Ber.*, **46**, 1304 (1913).
- Ethyl camphorcarboxylate. Lowry, Desch, and Southgate. *Trans.*, **97**, 899 (1910).
- „ „ benzoate. Lowry, Desch, and Southgate. *Trans.*, **97**, 899 (1910).

- Ethyl camphorcarboxylate valerate. Lowry, Desch, and Southgate. *Trans.*, **97**, 899 (1910).
- Ethyl *o*-carboxyphenoxyacetate, monamide. Merriman. *Trans.*, **103**, 1838 (1913).
- Ethyl chelidonate. Baly, Collie, and Watson. *Trans.*, **95**, 144 (1909).
- Ethyl cinnamate. Baly and Schaefer. *Trans.*, **93**, 1808 (1908).
- "    "    Pflüger. *Phys. Zeit.*, **10**, 406 (1909).
- "    "    Baly and Tryhorn. *Trans.*, **107**, 1058 (1915).
- Ethyl citrazinate. Baker and Baly. *Trans.*, **91**, 1122 (1907).
- Ethyl collidinedicarboxylate. Ley and v. Engelhardt. *Zeit. phys. Chem.*, **74**, 1 (1910).
- Ethyl coumaranonecarboxylate. Merriman. *Trans.*, **103**, 1838 (1913).
- "    "    acetyl derivative. Merriman. *Trans.*, **103**, 1838 (1913).
- Ethyl crotonate. Bielecki and Henri. *Compt. rend.*, **158**, 866 (1914).
- Ethyl isocyanate. Hartley, Dobbie, and Lauder. *Trans.*, **79**, 848 (1901).
- Ethyl cyanoacetate. Brannigan, Macbeth, and Stewart. *Trans.*, **103**, 406 (1913).
- Ethyl cyanurate. Crymble, Stewart, Wright, and Rea. *Trans.*, **99**, 1262 (1911).
- Ethyl isocyanurate. Hartley, Dobbie, and Lauder. *Trans.*, **79**, 848 (1901).
- "    "    Crymble, Stewart, Wright, and Rea. *Trans.*, **99**, 1262 (1911).
- Ethyl diacetylsuccinate. Baly and Desch. *Trans.*, **87**, 766 (1905).
- Ethyl diazoacetate. Hantzsch and Lifschitz. *Ber.*, **45**, 3011 (1912).
- Ethyl dibenzoylsuccinate. Hartley and Dobbie. *Trans.*, **77**, 498 (1900).
- Ethyl *p*-dichlorodimethoxyterephthalate. Hantzsch. *Ber.*, **48**, 772 (1915).
- Ethyl *p*-dichlorodioxyterephthalate. Hantzsch. *Ann.*, **384**, 135 (1911); *Ber.*, **48**, 772 (1915).
- Ethyl diethylacetoacetate. Stewart and Baly. *Trans.*, **89**, 489 (1906).
- "    "    Hantzsch. *Ber.*, **43**, 3049 (1910); **45**, 559 (1912).
- "    "    Hantzsch and Voigt. *Ber.*, **45**, 85 (1912).
- "    "    Bielecki and Henri. *Compt. rend.*, **158**, 866 (1914).
- Ethyl dihydrocollidinedicarboxylate. Baker and Baly. *Trans.*, **91**, 1122 (1907).
- "    "    Ley and v. Engelhardt. *Zeit. phys. Chem.*, **74**, 1 (1910).
- Ethyl diketobutyrate. Bielecki and Henri. *Compt. rend.*, **158**, 1022 (1914).
- Ethyl dimethylacetoacetate. Hantzsch. *Ber.*, **43**, 3049 (1910); **45**, 559 (1912); **48**, 772 (1915).
- Ethyl *p*-dimethylaminoazobenzoate. Hantzsch. *Ber.*, **46**, 1537 (1913).
- Ethyl dimethylsuccinylsuccinate. Hantzsch. *Ber.*, **48**, 772 (1915).
- Ethyl dinitrophenylmalonate. Hantzsch and Picton. *Ber.*, **42**, 2119 (1909).
- Ethyl dioxyterephthalate. Hantzsch. *Ber.*, **48**, 772 (1915).
- "    "    dibromide. Hantzsch. *Ber.*, **48**, 772 (1915).
- Ethyl dithiocarbonate. Purvis, Jones, and Tasker. *Trans.*, **97**, 2287 (1910).
- Ethyl dithiooxalate. Purvis, Jones, and Tasker. *Trans.*, **97**, 2287 (1910).
- Ethyl  $\beta$ -ethoxycrotonate. Baly and Desch. *Trans.*, **85**, 1029 (1904).
- "    "    Hantzsch. *Ber.*, **43**, 3049 (1910); **45**, 559 (1912).
- "    "    Hantzsch and Voigt. *Ber.*, **45**, 85 (1912).
- "    "    Hantzsch and Scharf. *Ber.*, **46**, 3570 (1912).
- Ethyl 3-ethoxy-1-1-dimethyl- $\Delta^3$ -cyclohexenylidene-5-cyanoacetate. Crossley and Gilling. *Trans.*, **97**, 518 (1910).
- Ethyl ethoxyfumarate. Baly and Desch. *Trans.*, **87**, 766 (1905).
- "    "    Hantzsch. *Ber.*, **48**, 1407 (1915).
- Ethyl ethylacetoacetate. Baly and Desch. *Trans.*, **85**, 1029 (1904).
- "    "    Hantzsch. *Ber.*, **43**, 3049 (1910).
- "    "    Bielecki and Henri. *Ber.*, **46**, 3627 (1913); *Compt. rend.*, **158**, 866 (1914).
- Ethyl formate. Hartley and Huntington. *Phil. Trans.*, **170**, I. 257 (1879).
- "    "    Bielecki and Henri. *Compt. rend.*, **155**, 1617 (1912); **156**, 550 (1913); *Ber.*, **46**, 1304 (1913).
- "    "    Hantzsch and Scharf. *Ber.*, **46**, 3570 (1913).
- Ethyl hydrazinocoumaranonecarboxylate. Merriman. *Trans.*, **103**, 1845 (1913).
- Ethyl 3-hydroxy-1-1-dimethyl- $\Delta^3$ -cyclohexenylidene-5-cyanoacetate. Crossley and Gilling. *Trans.*, **97**, 518 (1910).
- Ethyl 3-hydroxy-1-1-dimethyl- $\Delta^3$ -cyclohexenylidene-5-cyanoacetate ethyl ethers. Crossley and Gilling. *Trans.*, **97**, 518 (1910).

- Ethyl hydroxymethylenesuccinate. Baly and Desch. *Trans.*, **85**, 1029 (1904).
- Ethyl iodide. Crymble, Stewart, and Wright. *Ber.*, **43**, 1183 (1910).
- “ “ Ley and v. Engelhardt. *Zeit. phys. Chem.*, **74**, 1 (1910).
- Ethyl levulate. Stewart and Baly. *Trans.*, **89**, 489 (1906).
- “ “ Bielecki and Henri. *Compt. rend.*, **158**, 567, 866 (1914); *Ber.*, **47**, 1690 (1914).
- Ethyl methylacetoacetate. Hantzsch. *Ber.*, **43**, 3049 (1910).
- Ethyl nitrite. Harper and Macbeth. *Trans.*, **107**, 87 (1915).
- Ethyl *m*-nitrocinnamate. Baly, Tuck, and Marsden. *Trans.*, **97**, 571 (1910).
- Ethyl *o*-nitrocinnamate. Baly, Tuck, and Marsden. *Trans.*, **97**, 571 (1910).
- Ethyl *p*-nitrocinnamate. Baly, Tuck, and Marsden. *Trans.*, **97**, 571 (1910).
- Ethyl nitromalonate. Hantzsch and Voigt. *Ber.*, **45**, 85 (1912).
- Ethyl isonitrosoacetoacetate. Baly, Marsden, and Stewart. *Trans.*, **89**, 966 (1906).
- Ethyl isonitrosomalonnate. Baly, Marsden, and Stewart. *Trans.*, **89**, 966 (1906).
- Ethyl orthoformate. Hantzsch and Scharf. *Ber.*, **46**, 3570 (1912).
- Ethyl oxalate. Hantzsch and Scharf. *Ber.*, **46**, 3570 (1912).
- Ethyl oxaloacetate. Baly and Desch. *Trans.*, **87**, 766 (1905).
- Ethyl oxindonecarboxylate salts. Hantzsch. *Zeit. phys. Chem.*, **84**, 321 (1913).
- Ethyl phenoxycetate. Baly and Collie. *Trans.*, **87**, 1332 (1905).
- Ethyl phenylacetate. Baly and Collie. *Trans.*, **87**, 1332 (1905).
- “ “ Baly and Tryhorn. *Trans.*, **107**, 1058 (1915).
- Ethyl phthalate. Scheiber. *Ber.*, **46**, 2366 (1913).
- Ethyl propionate. Hartley and Huntington. *Phil. Trans.*, **170**, I, 257 (1879).
- “ “ Bielecki and Henri. *Ber.*, **46**, 1304 (1913); *Compt. rend.*, **155**, 1617 (1912); **156**, 550 (1913).
- Ethyl propyl ketone. Bielecki and Henri. *Ber.*, **46**, 3627 (1913); *Compt. rend.*, **156**, 1322 (1913).
- “ “ “ Rice. *Proc. Roy. Soc.*, **81A**, 76 (1914).
- Ethyl pyruvate. Stewart and Baly. *Trans.*, **89**, 489 (1906).
- “ “ Bielecki and Henri. *Ber.*, **47**, 1690 (1914); *Compt. rend.*, **158**, 567, 866 (1914).
- “ “ Henderson, Henderson, and Heilbron. *Ber.*, **47**, 876 (1914).
- Ethyl succinylsuccinate. Hantzsch. *Ber.*, **48**, 772 (1915).
- “ “ dichloride and tetrabromide. Hantzsch. *Ber.*, **48**, 772 (1915).
- Ethyl thioacetate. Hantzsch and Scharf. *Ber.*, **46**, 3570 (1913).
- Ethyl thiocarbonate. Purvis, Jones, and Tasker. *Trans.*, **97**, 2287 (1910).
- “ “ Hantzsch and Scharf. *Ber.*, **46**, 3570 (1913).
- Ethyl thioncarbonate. Purvis, Jones, and Tasker. *Trans.*, **97**, 2287 (1910).
- “ “ Hantzsch and Scharf. *Ber.*, **46**, 3570 (1913).
- Ethyl thionthiocarbonate. Purvis, Jones, and Tasker. *Trans.*, **97**, 2287 (1910).
- “ “ Hantzsch and Scharf. *Ber.*, **46**, 3570 (1913).
- Ethyl thiooxalate. Purvis, Jones, and Tasker. *Trans.*, **97**, 2287 (1910).
- “ “ Hantzsch and Scharf. *Ber.*, **46**, 3570 (1913).
- Ethyl triacetate. Baly, Collie, and Watson. *Trans.*, **95**, 144 (1909).
- Ethyl trimethylidihydropyridinedicarboxylate. Baker and Baly. *Trans.*, **91**, 1122 (1907).
- “ “ Ley and v. Engelhardt. *Zeit. phys. Chem.*, **74**, 1 (1910).
- Ethyl trinitrophenylmalonnate. Hantzsch and Picton. *Ber.*, **42**, 2119 (1909).
- Ethyl trithiocarbonate. Purvis, Jones, and Tasker. *Trans.*, **97**, 2287 (1910).
- Ethyl valerate. Hartley and Huntington. *Phil. Trans.*, **170**, I, 257 (1879).
- Ethyl xanthochelidonate. Baly, Collie, and Watson. *Trans.*, **95**, 144 (1909).
- Ethylamine. Hartley and Huntington. *Phil. Trans.*, **170**, I, 257 (1879).
- “ “ Bielecki and Henri. *Compt. rend.*, **156**, 1860 (1913).
- Ethylaniline. Purvis. *Trans.*, **97**, 1546 (1910).
- “ “ Baly and Tryhorn. *Trans.*, **107**, 1058 (1915).
- Ethylbenzene. Hartley and Huntington. *Phil. Trans.*, **170**, I, 257 (1879).
- “ “ Pauer. *Ann. der Phys.*, **61**, 363 (1897).
- “ “ Baly and Collie. *Trans.*, **87**, 1332 (1905).
- “ “ Grebe. *Zeit. wiss. Phot.*, **3**, 376 (1905).
- “ “ Hartley. *Phil. Trans.*, **208A**, 475 (1908); *Zeit. wiss. Phot.*, **6**, 299 (1908).
- “ “ Grebe. *Zeit. wiss. Phot.*, **9**, 130 (1910).



- Ethylbenzene. Kowalski. Bull. Akad. Sci., Cracovie, IA, 17 (1910).  
 ,, Ley and v. Engelhardt. Zeit. phys. Chem., **74**, 1 (1910).  
 ,, Stobbe and Ebert. Ber., **44**, 1289 (1911).  
 ,, Weimer. Zeit. wiss. Phot., **12**, 33 (1913).  
 Ethylene. Hartley. Trans., **39**, 153 (1881).  
 ,, Stark, Steubing, Enklaar, and Lipp. Jahrb. Radioak., **10**, 139 (1913).  
 ,, Stark and Lipp. Zeit. phys. Chem., **86**, 36 (1914).  
 Ethylene iodide. Crymble, Stewart, and Wright. Ber., **43**, 1183 (1910).  
 Ethylenediamine. Bielecki and Henri. Compt. rend., **156**, 1860 (1913).  
 Ethylenexylidine. Purvis. Trans., **97**, 644 (1910).  
 Ethylnitroamine, cobalt derivative. Franchimont and Backer. Trans., **101**, 2256 (1912).  
 ,, copper salt. Franchimont and Backer. Rec. Trav. Chim., **32**, 158 (1913).  
 ,, nickel salt. Franchimont and Backer. Rec. Trav. Chim., **32**, 321 (1913).  
 Ethylnitrolic acid. Hantzsch and Kanasirski. Ber., **42**, 889 (1909).  
 ,, ,, salts. Hantzsch and Kanasirski. Ber., **42**, 889 (1909).  
 Ethylnitrosohydroxylamine, copper salt. Franchimont and Backer. Rec. Trav. Chim., **32**, 158 (1913).  
 Ethylthiocarbonic acid. Hantzsch and Scharf. Ber., **46**, 3570 (1913).  
 Eugenol. Pfüger. Phys. Zeit., **10**, 406 (1909).  
 ,, Crymble, Stewart, Wright, and Glendinning. Trans., **99**, 451 (1911).  
*iso*Eugenol. Crymble, Stewart, Wright, and Glendinning. Trans., **99**, 451 (1911).

## F

- Fast red. Hartley. Trans., **51**, 152 (1887).  
 Fenchone. Henderson, Henderson, and Heilbron. Ber., **47**, 876 (1914).  
 ,, semicarbazone. Henderson, Henderson, and Heilbron. Ber., **47**, 876 (1914).  
 Fluorane. Meyer and Fischer. Ber., **46**, 70 (1913).  
 Fluorene. Baly and Tuck. Trans., **93**, 1902 (1908).  
 Fluorene ketone. Stobbe. Ber., **44**, 1481 (1911).  
 2-Fluorenediazonium chloride. Hantzsch and Lifschitz. Ber., **45**, 3011 (1912).  
 Fluorenoneanil hydrochloride. Reddelien. Ber., **47**, 1355 (1914).  
 Fluorenoneoxime. Lifschitz. Ber., **46**, 3233 (1913).  
 Fluorescein. Meyer and Marx. Ber., **40**, 3603 (1907); **41**, 2446 (1908).  
 ,, Kaempf. Phys. Zeit. **12**, 761 (1911).  
 ,, Meyer and Fischer. Ber., **44**, 1944 (1911); **46**, 70 (1913).  
 ,, Massol and Faucon. Bull. Soc. Chim., **13**, 217 (1913).  
 ,, Medhi and Watson. Trans., **107**, 1579 (1915).  
 Fluorobenzene. Ley and v. Engelhardt. Zeit. phys. Chem., **74**, 1 (1910).  
 ,, Strasser. Zeit. wiss. Phot., **14**, 281 (1915).  
*p*-Fluorophenetole. Purvis. Trans., **107**, 660 (1915).  
 Formaldehyde. Bielecki and Henri. Compt. rend., **155**, 456 (1912); Ber., **45**, 2819 (1912).  
 Formaldehydephenylhydrazone. Baly and Tuck. Trans., **89**, 982 (1906).  
 Formic acid. Hartley and Huntington. Phil. Trans., **170**, I. 257 (1879).  
 ,, ,, Bielecki and Henri. Compt. rend., **155**, 456 (1912); **156**, 550 (1913); Ber., **45**, 2819 (1912); **46**, 1304 (1913).  
 ,, ,, Henri. Ber., **46**, 3650 (1913).  
 ,, ,, Hantzsch and Scharf. Ber., **46**, 3570 (1913).  
 ,, ,, Wright. Trans., **103**, 528 (1913); **105**, 669 (1914).  
 ,, ,, salts. Hantzsch and Scharf. Ber., **46**, 3570 (1913).  
 ,, ,, ,, Wright. Trans., **103**, 528 (1913); **105**, 669 (1914).  
 Formylcamphor. Lowry and Southgate. Trans., **97**, 905 (1910).  
 Formylcamphoranhydride. Lowry and Southgate. Trans., **97**, 905 (1910).  
 Fuchsine. Hantzsch. Ber., **46**, 1537 (1913); **48**, 167 (1915).  
 Fuchsone. Meyer and Fischer. Ber., **46**, 70 (1913).  
 ,, Schlenk and Marcus. Ber., **47**, 1664 (1914).  
 Fuchsoniumcarbinol. Meyer and Fischer. Ber., **46**, 70 (1913).  
 Fulminic acid. Hantzsch and Voigt. Ber., **45**, 85 (1912).

- Fumaric acid. Magini. *Phys. Zeit.*, **5**, 69 (1904); *J. Chim. phys.*, **2**, 410 (1904).  
 " " Stewart. *Trans.*, **91**, 199 (1907).  
 " " Bielecki and Henri. *Compt. rend.*, **157**, 372 (1913); *Ber.*, **46**, 2596 (1913).  
 " " Wright. *Trans.*, **103**, 528 (1913).  
 " " Hantzsch. *Ber.*, **48**, 1407 (1915).  
 " " sodium salt. Wright. *Trans.*, **103**, 528 (1913).  
 Furan. Purvis. *Trans.*, **97**, 1648 (1910).  
 Furfuraldehyde. Hartley and Dobbie. *Trans.*, **73**, 598 (1898).  
 " Purvis. *Trans.*, **97**, 1648 (1910).  
 Furfuramide. Hartley and Dobbie. *Trans.*, **73**, 598 (1898).  
 Furfuran. Hartley and Dobbie. *Trans.*, **73**, 598 (1898).  
 Furfurof. Bielecki and Henri. *Ber.*, **47**, 1690 (1914).

## G

- Gallein. Medhi and Watson. *Trans.*, **107**, 1579 (1915).  
 Gelatine. Hartley. *Trans.*, **51**, 58 (1887).  
 Geraniolene. Stark, Steubing, Enklaar, and Lipp. *Jahrb. Radioak.*, **10**, 139 (1913).  
 Glucosazone. Baly, Tuck, Marsden, and Gazdar. *Trans.*, **91**, 1572 (1907).  
 Glucosemethylsazone. Baly, Tuck, Marsden, and Gazdar. *Trans.*, **91**, 1572 (1907).  
 Glucosephenylhydrazone. Baly, Tuck, Marsden, and Gazdar. *Trans.*, **91**, 1572 (1907).  
 Glucosephenylmethylhydrazone. Baly, Tuck, Marsden, and Gazdar. *Trans.*, **91**, 1572 (1907).  
 Glycine, cobalt salt. Ley and Winkler. *Ber.*, **42**, 3894 (1909); **45**, 372 (1912).  
 " copper salt. Ley. *Ber.*, **42**, 354 (1909).  
 " " Ley and Hegge. *Ber.*, **48**, 70 (1915).  
 Glyoxal. Purvis and McClelland. *Trans.*, **101**, 1810 (1912).  
 Glyoxalphenylmethylsazone. Baly, Tuck, Marsden, and Gazdar. *Trans.*, **91**, 1572 (1907).  
 Glyoxalphenylsazone. Baly, Tuck, Marsden, and Gazdar. *Trans.*, **91**, 1572 (1907).  
 Gnoscopine. Dobbie and Lauder. *Trans.*, **83**, 605 (1903).  
 Guaiacol. Baly and Ewbank. *Trans.*, **87**, 1347 (1905).  
 " Purvis and McClelland. *Trans.*, **103**, 1088 (1913).  
 " Wright. *Trans.*, **105**, 669 (1914).  
 Guanine hydrochloride. Hartley. *Trans.*, **87**, 1796 (1905).

## H

- Helianthin. Hartley. *Trans.*, **51**, 153 (1887).  
 " Hantzsch. *Ber.*, **46**, 1537 (1913); *Ber.*, **48**, 167 (1915).  
 Heptane. Hartley and Huntington. *Phil. Trans.*, **170**, I. 257 (1879).  
 Heptyl alcohol. Massol and Faucon. *Bull. Soc. Chim.*, **11**, 931 (1912).  
 Hexachlorobenzene. Hartley. *Trans.*, **39**, 153 (1881).  
 " Purvis. *Trans.*, **107**, 496 (1915).  
 Hexachlorocyclohexane. Purvis. *Trans.*, **107**, 496 (1915).  
 2.3.4-Hexachloropicoline. Purvis. *Trans.*, **95**, 294 (1909); **103**, 2283 (1913).  
 2.4-Hexadiene. Stark, Steubing, Enklaar, and Lipp. *Jahrb. Radioak.*, **10**, 139 (1913).  
 " Stark and Lipp. *Zeit. phys. Chem.*, **86**, 36 (1914).  
 Hexahydrophenylnitromethane. Zelinsky and Rosanoff. *Zeit. phys. Chem.*, **78**, 629 (1912).  
 1.2.4.5.6.8-Hexahydroxyanthraquinone. Meek and Watson. *Trans.*, **109**, 544 (1916).  
 1.2.3.5.6.7-Hexahydroxyanthraquinone. " " " " " "  
 Hexamethylacetone. Henderson, Henderson, and Heilbron. *Ber.*, **47**, 876 (1914).  
 " Rice. *Proc. Roy. Soc.*, **91A**, 76 (1914).  
 Hexamethylbenzene. Ley and v. Engelhardt. *Zeit. phys. Chem.*, **74**, 1 (1910).  
 " Purvis. *Trans.*, **107**, 496 (1915).  
 Hexamethylene. Hartley and Dobbie. *Trans.*, **77**, 846 (1900).  
 " Zelinsky and Rosanoff. *Zeit. phys. Chem.*, **78**, 629 (1912).  
 Hexamethyl-*p*-rosaniline. van der Plaats. *Ann. der Phys.*, **47**, 429 (1915).  
 Hexane. Hartley and Huntington. *Phil. Trans.*, **170**, I. 257 (1879).  
 Hexanitrohydrazobenzene. Hantzsch and Lister. *Ber.*, **43**, 1685 (1910).

- Hexaphenylethane. Baker. Trans., **91**, 1490 (1907).  
 Hexatriene. Baly and Tuck. Trans., **93**, 1902 (1908).  
 Hexyl alcohol. Massol and Faucon. Bull. Soc. Chim., **11**, 931 (1912).  
 Hexylene. Stark, Steubing, Enklaar, and Lipp. Jahrb. Radioak., **10**, 139 (1913).  
 Hippuric acid. Hartley and Huntington. Phil. Trans., **170**, I. 257 (1879).  
 " " Soret. Arch. des Sciences, **10**, 429 (1883).  
 " " Wright. Trans., **103**, 528 (1913).  
 " " sodium salt. Wright. Trans., **103**, 528 (1913).  
 Hofmann's violet. Hartley. Trans., **51**, 152 (1887).  
 Hydrastine. Dobbie and Lauder. Trans., **83**, 605 (1903).  
 " Hartley, Dobbie, and Lauder. Brit. Ass. Report, 1903, 126.  
 Hydrastinine. Dobbie and Lauder. Trans., **83**, 605 (1903).  
 " Hartley, Dobbie, and Lauder. Brit. Ass. Report, 1903, 126.  
 " Dobbie and Tinkler. Trans., **85**, 1005 (1904).  
 Hydrazinocoumaranonecarboxylic acid, ethyl ester. Merriman. Trans., **103**, 1845 (1913).  
 Hydrazobenzene. Purvis and McClelland. Trans., **101**, 1514 (1912).  
 Hydrocarbon, C<sub>11</sub>H<sub>16</sub>. Homer and Purvis. Trans., **93**, 1319 (1908).  
 Hydrocarbon, C<sub>21</sub>H<sub>14</sub>. Homer and Purvis. Trans., **97**, 1155 (1910).  
 Hydrocarbon, C<sub>22</sub>H<sub>20</sub>. Homer and Purvis. Trans., **97**, 1155 (1910).  
 Hydrocarbon, C<sub>26</sub>H<sub>22</sub>. Homer and Purvis. Trans., **93**, 1319 (1908).  
 Hydrocinnamic acid. See  $\beta$ -Phenylpropionic acid.  
 Hydrocotarnine. Dobbie, Lauder, and Tinkler. Trans., **83**, 598 (1903).  
 " Hantzsch. Ber., **44**, 1783 (1911).  
 Hydrocyanic acid. Hartley. Trans., **41**, 45 (1882).  
 Hydrohydrastinine. Dobbie and Tinkler. Trans., **85**, 1005 (1904).  
 Hydroquinone. See Quinol.  
 Hydroxy. See also Oxy-.  
 Hydroxyaposafrone. Balls, Hewitt, and Newman. Trans., **101**, 1840 (1912).  
*m*-Hydroxybenzaldehyde. Purvis. Trans. **105**, 2482 (1914).  
*o*-Hydroxybenzaldehyde. " " " " " " " "  
*p*-Hydroxybenzaldehyde. Tuck. Trans., **95**, 1809 (1909).  
 " Purvis. Trans., **105**, 2482 (1914).  
 " " " " " " " "  
*p*-Hydroxybenzaldehydephenylmethylhydrazone. Tuck. Trans., **95**, 1809 (1909).  
 4-Hydroxybenzeneazoforamide. Heilbron and Henderson. Trans., **103**, 1404 (1913).  
 " acetyl derivative. Heilbron and Henderson. Trans., **103**, 1404 (1913).  
 3-Hydroxy-1:1-dimethyl- $\Delta^3$ -cyclohexenylidene-5-cyanoacetic acid, ethyl ester. Crossley and Gilling. Trans., **97**, 518 (1910).  
 1-Hydroxy-2:6(?)-dinitronaphthacenequinone. Baly and Tuck. Trans., **91**, 426 (1907).  
 3-Hydroxyfluorone. Watson and Meek. Trans., **107**, 1567 (1915).  
 Hydroxylamine. Hartley and Dobbie. Trans., **77**, 318 (1900).  
 Hydroxylaminedisulphonic acid, potassium salt. Baly and Desch. Trans., **93**, 1747 (1908).  
 1-Hydroxy-5-methoxynaphthacenequinone. Baly and Tuck. Trans., **91**, 426 (1907).  
 1-Hydroxy-8(9)-methoxynaphthacenequinone. Baly and Tuck. Trans., **91**, 426 (1907).  
 4-Hydroxy-3-methoxytoluene. Dobbie and Fox. Trans., **105**, 1639 (1914).  
 Hydroxymethylenecamphor. Baly and Desch. Trans., **87**, 766 (1905).  
 " Lowry and Southgate. Trans., **97**, 905 (1910).  
 Hydroxymethyleneindandione. Lifschitz. Ber., **47**, 1401 (1914).  
 Hydroxymethylenesuccinic acid, ethyl ester. Baly and Desch. Trans., **85**, 1029 (1904).  
 4-Hydroxy-3-methyl-5-isopropylbenzeneazoforamide. Heilbron and Henderson. Trans., **103**, 1404 (1913).  
 1-Hydroxynaphthacenequinone. Baly and Tuck. Trans., **91**, 426 (1907).  
 Hydroxyquinolbenzein. Medhi and Watson. Trans., **107**, 1579 (1915).  
 6-Hydroxyquinoline. Dobbie and Fox. Trans., **101**, 77 (1912).  
 8-Hydroxyquinoline. Fox. Trans., **97**, 1119, 1337 (1910).  
 Hydroxystilbene. Hewitt, Lewcock, and Pope. Trans., **101**, 604 (1912).  
 8-Hydroxytetrahydroquinoline. Fox. Trans., **97**, 1119 (1910).

- 4-Hydroxy-*m*-tolueneazofornamide. Heilbron and Henderson. *Trans.*, **103**, 1404 (1913).  
 Hyoscyamine. Hartley. *Phil. Trans.*, **176**, 471 (1885).  
 „ Dobbie and Fox. *Trans.*, **103**, 1193 (1913).  
 Hyoscine. Dobbie and Fox. *Trans.*, **103**, 1193 (1913).  
 Hypoxanthine. Soret. *Arch. des Sciences*, **10**, 429 (1883).

## I

- Indonecyclomethylacetoethylene. Purvis. *Trans.*, **99**, 107 (1911).  
 Iodine green. Hartley. *Trans.*, **51**, 153 (1887).  
 4-Iodoacenaphthene. Purvis. *Trans.*, **101**, 1315 (1912).  
*m*-Iodoaniline. Purvis. *Trans.*, **103**, 1638 (1913).  
*o*-Iodoaniline. Purvis. *Trans.*, **103**, 1638 (1913).  
*p*-Iodoaniline. Purvis. *Trans.*, **103**, 1638 (1913).  
 Iodoazobenzene. Hewitt and Thole. *Trans.*, **97**, 511 (1910).  
 Iodobenzene. Pauer. *Ann. der Phys.*, **61**, 363 (1897).  
 „ Grebe. *Zeit. wiss. Phot.*, **3**, 376 (1905).  
 „ Purvis. *Trans.*, **99**, 2318 (1911).  
 „ Ley and v. Engelhardt. *Zeit. phys. Chem.*, **74**, 1 (1910).  
*m*-Iodobenzoic acid. Purvis. *Trans.*, **107**, 966 (1915).  
*o*-Iodobenzoic acid. Purvis. *Trans.*, **107**, 966 (1915).  
*p*-Iodobenzoic acid. Purvis. *Trans.*, **107**, 966 (1915).  
 Iodoform. Crymble, Stewart, and Wright. *Ber.*, **43**, 1183 (1910).  
 „ Ley and v. Engelhardt. *Zeit. phys. Chem.*, **74**, 1 (1910).  
*p*-Iodophenol. Purvis. *Trans.*, **103**, 1638 (1913).  
*m*-Iodotoluene. Purvis. *Trans.*, **99**, 2318 (1911).  
*o*-Iodotoluene. Purvis. *Trans.*, **99**, 2318 (1911).  
 Isatin. Hartley and Dobbie. *Trans.*, **75**, 640 (1899).  
 Itaconic acid. Stewart. *Trans.*, **91**, 199 (1907).  
 „ „ Bielecki and Henri. *Ber.*, **46**, 2596 (1913).

## J

- Japaconitine. Hartley. *Phil. Trans.*, **176**, 471 (1885).

## K

- 4-Keto-3-acetyl-5-benzylidene-2-methylidihydrofuran. Purvis. *Trans.*, **99**, 107 (1911).  
 Keto-fluorene. Stobbe. *Ber.*, **48**, 441 (1915).  
 9-Keto-fluorene-4-carboxylic acid. Stobbe. *Ber.*, **48**, 441 (1915).  
 „ „ ethyl ester. Stobbe. *Ber.*, **48**, 441 (1915).

## L

- Lactic acid. Bielecki and Henri. *Ber.*, **46**, 2596 (1913).  
 Laudanine. Dobbie and Lauder. *Trans.*, **83**, 626 (1903); *Brit. Ass. Report*, 1903, 166.  
 Laudanosine. Dobbie and Lauder. *Trans.*, **83**, 626 (1903); *Brit. Ass. Report*, 1903, 166.  
 „ Dobbie and Fox. *Trans.*, **105**, 1639 (1914).  
 Lauric acid. Hantzsch and Scharf. *Ber.*, **46**, 3570 (1913).  
 Laurinol. Hantzsch. *Ber.*, **45**, 553 (1912).  
 Leucine. Soret. *Arch. des Sciences*, **10**, 429 (1883).  
 Limonene. Crymble, Stewart, Wright, and Rea. *Trans.*, **99**, 1262 (1911).  
 „ Hantzsch. *Ber.*, **45**, 553 (1912).  
 „ Stark, Steubing, Enklaar, and Lipp. *Jahrb. Radioak.*, **10**, 139 (1913).  
 Lithium urate. Hartley. *Trans.*, **87**, 1796 (1905).  
 2.4-Lutidine. Purvis. *Trans.*, **97**, 692 (1910).  
 2.6-Lutidine. Baker and Baly. *Trans.*, **91**, 1122 (1907).  
 „ Purvis. *Trans.*, **97**, 692 (1910).  
 $\gamma$ -Lutidone. Baker and Baly. *Trans.*, **91**, 1122 (1907).

## M

- Maleic acid. Magini. *J. Chim. phys.*, **2**, 410 (1904).  
 " " Stewart. *Trans.*, **91**, 199 (1907).  
 " " Bielecki and Henri. *Ber.*, **46**, 2696 (1913); *Compt. rend.*, **157**, 372 (1913).  
 " " Hantzsch. *Ber.*, **48**, 1407 (1915).  
 Malic acid. Bielecki and Henri. *Ber.*, **46**, 2596 (1913).  
 Malonamide. Brannigan, Macbeth, and Stewart. *Trans.*, **103**, 406 (1913).  
 Malonic acid. Bielecki and Henri. *Compt. rend.*, **155**, 456 (1912); *Ber.*, **45**, 2819 (1912); **46**, 2596 (1913).  
 " " Wright. *Trans.*, **103**, 528 (1913); **105**, 669 (1914).  
 " " sodium salts. Brannigan, Macbeth, and Stewart. *Trans.*, **103**, 406 (1913).  
 " " " " Wright. *Trans.*, **103**, 528 (1913); **105**, 669 (1914).  
 Mandelic acid. Ley and v. Engelhardt. *Zeit. phys. Chem.*, **74**, 1 (1910).  
 " " Purvis. *Trans.*, **107**, 966 (1915).  
 Mandelonitrite. Purvis. *Trans.*, **105**, 2482 (1914).  
 Melamine. Hartley, Dobbie, and Lauder. *Trans.*, **79**, 848 (1901).  
 Melisyl alcohol. Massol and Faucon. *Bull. Soc. Chim.*, **11**, 931 (1912).  
 Menthone. Henderson, Henderson, and Heilbron. *Ber.*, **47**, 876 (1914).  
 Mercuric acetate. Crymble. *Trans.*, **105**, 658 (1914).  
 Mercurydibenzyl. Ley and v. Engelhardt. *Zeit. phys. Chem.*, **74**, 1 (1910).  
 " " Purvis and McClelland. *Trans.*, **101**, 1514 (1912).  
 Mercurydiethyl. Crymble. *Trans.*, **105**, 658 (1914).  
 Mercurydimethyl. Crymble. *Trans.*, **105**, 658 (1914).  
 Mercurydiphenyl. Purvis and McClelland. *Trans.*, **101**, 1514 (1912).  
 Mercuryethyl chloride. Ley and Fischer. *Zeit. anorg. Chem.*, **82**, 329 (1913).  
 " " Crymble. *Trans.*, **105**, 658 (1914).  
 Mercuryethyl iodide. Crymble. *Trans.*, **105**, 558 (1914).  
 Mercuryethyl bromide. Crymble. *Trans.*, **105**, 658 (1914).  
 Mercuryethyl chloride. Ley and Fischer. *Zeit. anorg. Chem.*, **82**, 329 (1913).  
 " " Crymble. *Trans.*, **105**, 658 (1914).  
 Mercuryethyl iodide. Crymble. *Trans.*, **105**, 658 (1914).  
 Mercurypropionamide. Ley and Fischer. *Zeit. anorg. Chem.*, **82**, 329 (1913).  
 Mercurysuccinimide. Ley and Fischer. *Zeit. anorg. Chem.*, **82**, 329 (1913).  
 Mesaconic acid. Stewart. *Trans.*, **91**, 199 (1907).  
 " " Bielecki and Henri. *Compt. rend.*, **157**, 372 (1913); *Ber.*, **46**, 2596 (1913).  
 Mesidine. Purvis. *Trans.*, **97**, 1546 (1910).  
 Mesityl oxide. Purvis and McClelland. *Trans.*, **103**, 433 (1913).  
 " " Brannigan, Macbeth, and Stewart. *Trans.*, **103**, 406 (1913).  
 " " Henderson, Henderson, and Heilbron. *Ber.*, **47**, 876 (1914).  
 " " Bielecki and Henri. *Compt. rend.*, **158**, 567, 866, 1022 (1914); *Ber.*, **47**, 1690 (1914).  
 Mesitylsemicarbazone. Wilson and Heilbron. *Trans.*, **103**, 377 (1913).  
 Mesitylene. Hartley and Huntington. *Phil. Trans.*, **170**, 1, 257 (1879).  
 " " Hartley. *Phil. Trans.*, **208**, A, 475 (1908); *Zeit. wiss. Phot.*, **6**, 299 (1908).  
 " " Baly and Tryhorn. *Trans.*, **107**, 1058 (1915).  
 Mesotartaric acid. Stewart. *Trans.*, **91**, 1537 (1907).  
 Methaneazobenzene. *See Benzeneazomethane.*  
 Methazonic acid. Hantzsch and Voigt. *Ber.*, **45**, 85 (1912).  
 o-Methoxybenzaldehyde. Tuck. *Trans.*, **95**, 1809 (1909).  
 o-Methoxybenzaldehydophenylmethylhydrazone. Tuck. *Trans.*, **95**, 1809 (1909).  
 p-Methoxybenzeneazodimethylaniline. Hewitt and Thomas. *Trans.*, **95**, 1292 (1909).  
 " " Hantzsch. *Ber.*, **46**, 1537 (1913).  
 p-Methoxybenzeneazophenol. Tuck. *Trans.*, **95**, 1809 (1909).  
 p-Methoxybenzenediazocyanide. Dobbie and Tinkler. *Trans.*, **87**, 273 (1905).  
 o-Methoxybenzoic acid. Ley and v. Engelhardt. *Zeit. phys. Chem.*, **74**, 1 (1910).  
 " " sodium salt. Ley and v. Engelhardt. *Zeit. phys. Chem.*, **74**, 1 (1910).

- p*-Methoxybenzoic acid. Ley and v. Engelhardt. Zeit. phys. Chem., **74**, 1 (1910).  
 " " sodium salt. Ley and v. Engelhardt. Zeit. phys. Chem., **74**, 1 (1910).
- p*-Methoxybenzylideneaminoazobenzene. Pope and Willett. Trans., **103**, 1258 (1913).
- 6-Methoxyquinoline. Dobbie and Fox. Trans., **101**, 77 (1912).
- Methoxystilbene. Hewitt, Lewcock, and Pope. Trans., **101**, 604 (1912).
- Methyl acetate. Hartley and Huntington. Phil. Trans., **170**, 1, 257 (1879).  
 " " Bielecki and Henri. Compt. rend., **155**, 456 (1912); **156**, 550 (1913); Ber., **45**, 2819 (1912); **46**, 1304 (1913).
- Methyl acetoacetate. Bielecki and Henri. Compt. rend., **156**, 1322 (1913).
- Methyl alcohol. Hartley and Huntington. Phil. Trans., **170**, 1, 257 (1879).  
 " " Bielecki and Henri. Compt. rend., **155**, 456 (1912); Ber., **45**, 2819 (1912).  
 " " Massol and Faucon. Bull. Soc. Chim., **11**, 931 (1912).
- Methyl allyl ketone. Purvis and McClelland. Trans., **103**, 433 (1913).
- Methyl benzoate. Pfüger. Phys. Zeit., **10**, 406 (1909).  
 " " Crymble, Stewart, Wright, and Glendinning. Trans., **99**, 451 (1911).
- Methyl butyl ketone. Bielecki and Henri. Compt. rend., **156**, 1322 (1913); Ber., **46**, 3627 (1913).  
 " " " Rice. Proc. Roy. Soc., **91A**, 76 (1914).
- Methyl isobutyl ketone. Bielecki and Henri. Compt. rend., **156**, 1322 (1913); **158**, 567 (1914); Ber., **46**, 3627 (1913); **47**, 1690 (1914).  
 " " " Henderson, Henderson, and Heilbron. Ber., **47**, 876 (1914).  
 " " " Rice. Proc. Roy. Soc., **91A**, 76 (1914).
- Methyl butyrate. Hartley and Huntington. Phil. Trans., **170**, 1, 257 (1879).  
 " " Bielecki and Henri. Compt. rend., **155**, 1617 (1912); **156**, 550 (1913); Ber., **46**, 1304 (1913).
- Methyl camphorcarboxylate. Lowry, Desch, and Southgate. Trans., **97**, 899 (1910).  
 " " acetate. Lowry, Desch, and Southgate. Trans., **97**, 899 (1910).
- Methyl cinnamylidenemalonate. Baly and Schaefer. Trans., **93**, 1808 (1908).
- Methyl isocyanate. Hartley, Dobbie, and Lauder. Trans., **79**, 848 (1901).
- Methyl *o*-cyanobenzoate. Scheiber. Ber., **45**, 2398 (1912).
- Methyl isocyanide. Bielecki and Henri. Compt. rend., **156**, 1860 (1913).
- Methyl isocyanurate. Hartley, Dobbie, and Lauder. Trans., **79**, 848 (1901).
- Methyl dimethylanthranilate. Ley and Ulrich. Ber., **42**, 3440 (1909).
- Methyl ethyl ketone. Stewart and Baly. Trans., **89**, 489 (1906).  
 " " " Bielecki and Henri. Compt. rend., **155**, 456 (1912); **156**, 1322 (1913); Ber., **45**, 2819 (1912); **46**, 3627 (1913).  
 " " " Henderson, Henderson, and Heilbron. Ber., **47**, 876 (1914).  
 " " " Rice. Proc. Roy. Soc., **91A**, 76 (1914).
- Methyl formate. Hartley and Huntington. Phil. Trans., **170**, I, 257 (1879).  
 " " Bielecki and Henri. Compt. rend., **155**, 1617 (1912); **156**, 550 (1913); Ber., **46**, 1304 (1913).  
 " " Hantzsch and Scharf. Ber., **46**, 3570 (1913).
- Methyl hexyl ketone. Stewart and Baly. Trans., **89**, 489 (1906).  
 " " " Bielecki and Henri. Compt. rend., **156**, 1322 (1913); Ber., **46**, 3627 (1913).  
 " " " Henderson, Henderson, and Heilbron. Ber., **47**, 876 (1914).  
 " " " Rice. Proc. Roy. Soc., **91A**, 76 (1914).
- Methyl iodide. Crymble, Stewart, and Wright. Ber., **43**, 1183 (1910).
- Methyl malonate. Brannigan, Macbeth, and Stewart. Trans., **103**, 406 (1913).
- Methyl methylanthranilate. Ley and Ulrich. Ber., **42**, 3440 (1909).
- Methyl nonyl ketone. Stewart and Baly. Trans., **89**, 489 (1906).  
 " " " Henderson, Henderson, and Heilbron. Ber., **47**, 876 (1914).  
 " " " Rice. Proc. Roy. Soc., **91A**, 76 (1914).
- Methyl oxalate. Crymble, Stewart, Wright, and Rea. Trans., **99**, 1262 (1911).  
 " " Hantzsch and Scharf. Ber., **46**, 3570 (1913).
- Methyl *o*-oxybenzoate. Ley and v. Engelhardt. Zeit. phys. Chem., **74**, 1 (1910).
- Methyl propenyl ketone. Purvis and McClelland. Trans., **103**, 433 (1913).
- Methyl propiolate. Bielecki and Henri. Ber., **46**, 2596 (1913).

- Methyl propionate. Bielecki and Henri. *Compt. rend.*, **155**, 1617 (1912); **156**, 550 (1913); *Ber.*, **46**, 1304, 2596 (1913).
- Methyl propyl ketone. Stewart and Baly. *Trans.*, **89**, 489 (1906).
- "    "    Rice. *Proc. Roy. Soc.*, **91A**, 76 (1914).
- Methyl isopropyl ketone. Stewart and Baly. *Trans.*, **89**, 489 (1906).
- "    "    "    Henderson, Henderson, and Heilbron. *Ber.*, **47**, 876 (1914).
- "    "    "    Rice. *Proc. Roy. Soc.*, **91A**, 76 (1914).
- Methyl salicylate. Hartley and Huntington. *Phil. Trans.*, **170**, I. 257 (1879).
- "    "    Pfüger. *Phys. Zeit.*, **10**, 406 (1909).
- Methyl 2,3,4-trichloropicolinate. Purvis. *Trans.*, **103**, 2283 (1913).
- Methyl valerate. Hartley and Huntington. *Phil. Trans.*, **170**, I. 257 (1879).
- "    "    Bielecki and Henri. *Compt. rend.*, **155**, 1617 (1912); **156**, 550 (1913); *Ber.*, **46**, 1304 (1913).
- Methylacetanilide. Baly, Tuck, and Marsden. *Trans.*, **97**, 571 (1910).
- Methylacetylacetone. Baly and Desch. *Trans.*, **85**, 1029 (1904); *Astrophys. Journ.*, **23**, 110 (1906).
- "    Morgan and Moss. *Trans.*, **103**, 78 (1913).
- "    Morgan and Reilly. *Trans.*, **103**, 1494 (1913).
- "    Bielecki and Henri. *Compt. rend.*, **158**, 1022 (1914).
- Methylamine. Hartley and Huntington. *Phil. Trans.*, **170**, I. 257 (1879).
- "    Hartley and Dobbie. *Trans.*, **77**, 318 (1900).
- "    Bielecki and Henri. *Compt. rend.*, **156**, 1860 (1913).
- Methylaminomethylmalcinmethylimide. Ley and Fischer. *Ber.*, **46**, 327 (1913).
- Methylaniline. Baly and Collie. *Trans.*, **87**, 1332 (1905).
- "    Purvis. *Trans.*, **97**, 1546 (1910).
- Methylantranil. Scheiber. *Ber.*, **44**, 2409 (1911).
- Methylantranilic acid. Ley and Ulrich. *Ber.*, **42**, 3440 (1909).
- "    "    methyl ester. Ley and Ulrich. *Ber.*, **42**, 3440 (1909).
- $\beta$ -Methylbutadiene. Stark, Steubing, Enklaar, and Lipp. *Jahrb. Radioak.*, **10**, 139 (1913).
- "    Stark and Lipp. *Zeit. phys. Chem.*, **86**, 36 (1914).
- $\alpha$ -Methylcamphor. Lowry and Desch. *Trans.*, **85**, 807, 1340 (1909).
- Methylcarbostyryl. Hartley and Dobbie. *Trans.*, **75**, 640 (1899).
- Methyl- $\psi$ -carbostyryl. Hartley and Dobbie. *Trans.*, **75**, 640 (1899).
- Methylcarbylamine. Bielecki and Henri. *Compt. rend.*, **156**, 1860 (1913).
- m*-Methylcyclohexanone. Henderson, Henderson, and Heilbron. *Ber.*, **47**, 876 (1914).
- o*-Methylcyclohexanone. Henderson, Henderson, and Heilbron. *Ber.*, **47**, 876 (1914).
- p*-Methylcyclohexanone. Henderson, Henderson, and Heilbron. *Ber.*, **47**, 876 (1914).
- Methylene iodide. Crymble, Stewart, and Wright. *Ber.*, **43**, 1183 (1910).
- Methylene camphor. Lowry and Southgate. *Trans.*, **97**, 905 (1910).
- Methyleugenol. Pfüger. *Phys. Zeit.*, **10**, 406 (1909).
- Methylheptenone. Bielecki and Henri. *Compt. rend.*, **158**, 567, 1022 (1914); *Ber.*, **47**, 1690 (1914).
- "    Henderson, Henderson, and Heilbron. *Ber.*, **47**, 876 (1914).
- Methylhexamethylene. Zelinsky and Rosanoff. *Zeit. phys. Chem.*, **78**, 629 (1912).
- Methylisatin. Hartley and Dobbie. *Trans.*, **75**, 640 (1899).
- Methyl- $\psi$ -isatin. Hartley and Dobbie. *Trans.*, **75**, 640 (1899).
- Methylnitroamide. Baly and Desch. *Trans.*, **93**, 1747 (1908).
- "    cobalt salt. Franchimont and Backer. *Trans.*, **101**, 2256 (1912).
- "    copper salt. Franchimont and Backer. *Rec. Trav. Chim.*, **32**, 158 (1913).
- "    nickel salt. Franchimont and Backer. *Rec. Trav. Chim.*, **32**, 158 (1913).
- 1,1-Methylnitrocyclohexane. Zelinsky and Rosanoff. *Zeit. phys. Chem.*, **78**, 629 (1912).
- 1,1-Methylnitrocyclopentane. Zelinsky and Rosanoff. *Zeit. phys. Chem.*, **78**, 629 (1912).
- Methyloxindone. Hantzsch. *Zeit. phys. Chem.*, **84**, 321 (1913).
- "    salts. Hantzsch. *Zeit. phys. Chem.*, **84**, 321 (1913).
- Methylpentamethylene. Zelinsky and Rosanoff. *Zeit. phys. Chem.*, **78**, 629 (1912).
- Methylphenanthridine cyanide. Tinkler. *Trans.*, **89**, 856 (1906).

- Methylphenazonium salts. Hantzsch. Ber., **49**, 511 (1916).  
*n*-Methylphenylacridonium salts. Hantzsch. Ber., **42**, 68 (1909).  
Methylphenylacridonium chloride. Hantzsch. Ber., **44**, 1783 (1911).  
    "    iodide. Hantzsch. Ber., **44**, 1783 (1911).  
*α*-Methylphenylpicramide. Hantzsch. Ber., **43**, 1651, 1662 (1910).  
*β*-Methylphenylpicramide. Hantzsch. Ber., **43**, 1651, 1662 (1910).  
Methylisophthalamide. Scheiber. Ber., **45**, 2398 (1912).  
1-Methyl-2-pyridone. Baker and Baly. Trans., **91**, 1122 (1907).  
*n*-Methylthioacetanilide. May. Trans., **103**, 2272 (1913).  
*n*-Methylthiobenzanilide. May. Trans., **103**, 2272 (1913).  
*s*-Methylthiobenzanilide. May. Trans., **103**, 2272 (1913).  
Methyl-*o*-tolylpicramide. Hantzsch. Ber., **43**, 1662 (1910).  
Methyl-*p*-tolylpicramide. Hantzsch. Ber., **43**, 1662 (1910).  
Morphine. Hartley. Phil. Trans., **176**, 471 (1885).  
"    Dobbie and Lauder. Trans., **83**, 605 (1903).  
"    Hartley, Dobbie, and Lauder. Brit. Ass. Report, 1903, 126.  
"    Gompel and Henri. Compt. rend., **157**, 1422 (1913).  
"    Dobbie and Fox. Trans., **105**, 1639 (1914).  
Murexide. Hartley. Trans., **51**, 153 (1887); **87**, 1796 (1905).  
"    Lifschitz. Ber., **47**, 1068 (1914).

### N

- Naphthacenequinone derivatives. Baly and Tuck. Trans., **91**, 426 (1907).  
Naphthalene. Hartley. Trans., **39**, 153 (1881); **47**, 685 (1885).  
"    Baly and Tuck. Trans., **93**, 1902 (1908).  
"    Homer and Purvis. Trans., **97**, 280 (1910).  
"    Leonard. Trans., **97**, 1246 (1910).  
"    Purvis. Trans., **101**, 1315 (1912).  
"    Stark and Levy. Jahrb. Radioak., **10**, 179 (1913).  
"    Baly. Phil. Mag., **29**, 223 (1915).  
*α*-Naphthalenediazonium chloride. Hantzsch and Lifschitz. Ber., **45**, 3011 (1912).  
"    "    Cain. Ber., **46**, 101 (1913).  
*α*-Naphthaquinone. Baly and Stewart. Trans., **89**, 502 (1906).  
"    "    Purvis. Trans., **101**, 1315 (1912).  
*β*-Naphthaquinone. Purvis. Trans., **101**, 1315 (1912).  
*β*-Naphthaquinonephenylhydrazone. Tuck. Trans., **95**, 1809 (1909).  
*α*-Naphthaquinonephenylmethylhydrazone. Tuck. Trans., **95**, 1809 (1909).  
Naphthazarine. Meyer and Fischer. Ber., **46**, 85 (1913).  
*α*-Naphthol. Purvis. Trans., **101**, 1315 (1912).  
*β*-Naphthol. Purvis. Trans., **101**, 1315 (1912).  
*β*-Naphthol sulphides. Crymble, Ross, and Smiles. Trans., **101**, 1146 (1912).  
*α*-Naphthylamine. Purvis. Trans., **101**, 1315 (1912).  
*α*-Naphthylamine-*β*-naphtholdisulphonic acid, azo dye from. van der Plaats. Anu. der Phys., **47**, 429 (1915).  
*β*-Naphthylamine. Purvis. Trans., **101**, 1315 (1912).  
"    "    Morgan and Reilly. Trans., **103**, 1494 (1913).  
Naphthylaminochlorophenylphenazonium chloride. Balls, Hewitt, and Newman. Trans., **101**, 1840 (1912).  
Narceine. Hartley. Phil. Trans., **176**, 471 (1885).  
"    "    Dobbie and Lauder. Trans., **83**, 605 (1903).  
"    "    Hartley, Dobbie, and Lauder. Brit. Ass. Report, 1903, 126.  
Narcotine. Hartley. Phil. Trans., **176**, 471 (1885).  
"    "    Dobbie and Lauder. Trans., **83**, 605 (1903).  
"    "    Hartley, Dobbie, and Lauder. Brit. Ass. Report, 1903, 126.  
Nicotine. Hartley. Phil. Trans., **176**, 471 (1885).  
"    "    Purvis. Trans., **97**, 1035 (1910).  
"    "    Dobbie and Fox. Trans., **103**, 1193 (1913).  
Nitroacetaldoxime. Hantzsch and Voigt. Ber., **45**, 85 (1912).  
Nitroacetic acid. Hantzsch and Voigt. Ber., **45**, 85 (1912).  
"    "    "    potassium salt. Hantzsch and Voigt. Ber., **45**, 85 (1912).  
Nitroacetophenonephenylmethylhydrazone. Baly and Tuck. Trans., **89**, 982 (1906).  
Nitroaceto-*p*-toluidide. Baly, Tuck, and Marsden. Trans., **97**, 571 (1910).



- 2-Nitro-4-acetyl-*p*-phenylenediamine. Morgan, Moss, and Porter. Trans., **107**, 1296 (1915).
- Nitroamide. Baly and Desch. Trans., **93**, 1747 (1908).
- 2-Nitro-4-aminophenol. Morgan, Moss, and Porter. Trans., **107**, 1296 (1915).
- 2-Nitro-5-aminophenol. " " " " " " " "
- 3-Nitro-4-aminophenol. " " " " " " " "
- 4-Nitro-3-aminophenol. " " " " " " " "
- 5-Nitro-2-aminophenol. " " " " " " " "
- 2-Nitro-4-aminotoluene. " " " " " " " "
- 2-Nitro-5-aminotoluene. " " " " " " " "
- 2-Nitro-6-aminotoluene. " " " " " " " "
- 3-Nitro-2-aminotoluene. " " " " " " " "
- 3-Nitro-4-aminotoluene. " " " " " " " "
- 3-Nitro-6-aminotoluene. " " " " " " " "
- 4-Nitro-2-aminotoluene. " " " " " " " "
- 4-Nitro-3-aminotoluene. " " " " " " " "
- 5-Nitro-4-amino-*m*-xylene. " " " " " " " "
- 6-Nitro-4-amino-*m*-xylene. " " " " " " " "
- m*-Nitroaniline. Hartley and Huntington. Phil. Trans., **170**, I, 257 (1879).
- " Baly, Edwards, and Stewart. Trans., **89**, 514 (1906).
- " Baly, Tuck, and Marsden. Trans., **97**, 571 (1910).
- o*-Nitroaniline. Hartley and Huntington. Phil. Trans., **170**, I, 257 (1879).
- " Morgan, Jobling, and Barnett. Trans., **101**, 1209 (1912).
- " Cain, Macbeth, and Stewart. Trans., **103**, 568 (1913).
- " Purvis and McClelland. Trans., **103**, 1088 (1913).
- p*-Nitroaniline. Hartley and Huntington. Phil. Trans., **170**, I, 257 (1879).
- " Baly, Edwards, and Stewart. Trans., **89**, 514 (1906).
- " Baly, Tuck, and Marsden. Trans., **97**, 571 (1910).
- " Cain, Macbeth, and Stewart. Trans., **103**, 568 (1913).
- 2-Nitro-6-anilino-1-hydroxynaphthacenequinone. Baly and Tuck. Trans., **91**, 426 (1907).
- o*-Nitroanisole. Baly, Edwards, and Stewart. Trans., **89**, 514 (1906).
- " Baly, Tuck, and Marsden. Trans., **97**, 571 (1910).
- " Baly and Rice. Trans., **101**, 1475 (1912).
- " Purvis and McClelland. Trans., **103**, 1088 (1913).
- p*-Nitroanisole. Baly, Edwards, and Stewart. Trans., **89**, 514 (1906).
- " Baly and Rice. Trans., **101**, 1475 (1912).
- " Purvis and McClelland. Trans., **103**, 1088 (1913).
- Nitroanthrone. Hantzsch and Korczynski. Ber., **42**, 1216 (1909).
- Nitrobarbituric acid. Hantzsch and Voigt. Ber., **45**, 85 (1912).
- m*-Nitrobenzaldehyde. Purvis and McClelland. Trans., **103**, 1088 (1913).
- o*-Nitrobenzaldehyde. Purvis and McClelland. Trans., **103**, 1088 (1913).
- p*-Nitrobenzaldehyde. Purvis and McClelland. Trans., **103**, 1088 (1913).
- m*-Nitrobenzaldehydephenylhydrazone. Baly and Tuck. Trans., **89**, 982 (1906).
- o*-Nitrobenzaldehydephenylhydrazone. Baly and Tuck. Trans., **89**, 982 (1906).
- p*-Nitrobenzaldehydephenylhydrazone. Baly and Tuck. Trans., **89**, 982 (1906).
- " Hewitt, Johnson, and Pope. Trans., **105**, 364 (1914).
- " acetyl derivative. Hewitt, Johnson, and Pope. Trans., **105**, 364 (1914).
- m*-Nitrobenzaldehydephenylmethylhydrazone. Baly and Tuck. Trans., **89**, 982 (1906).
- o*-Nitrobenzaldehydephenylmethylhydrazone. Baly and Tuck. Trans., **89**, 982 (1906).
- p*-Nitrobenzaldehydephenylmethylhydrazone. Baly and Tuck. Trans., **89**, 982 (1906).
- p*-Nitrobenzantialdoxime. Hantzsch. Ber., **43**, 1651 (1910).
- " Brady. Trans., **105**, 2104 (1914).
- p*-Nitrobenzsynaldoxime. Hantzsch. Ber., **43**, 1651 (1910).
- " Brady. Trans., **105**, 2104 (1914).
- Nitrobenzene. Pauer. Ann. der Phys., **63**, 363 (1897).
- " Baly and Collie. Trans., **87**, 1332 (1905).
- " Crymble, Stewart, and Wright. Ber., **43**, 1191 (1910).

- Nitrobenzene. Purvis and McClelland. *Trans.*, **103**, 1088 (1913).  
 ,, Baly and Rice. *Trans.*, **103**, 2085 (1913).  
 ,, Baly and Tryhorn. *Trans.*, **107**, 1058 (1915).  
*p*-Nitrobenzeneazobenzeneazophenol. Pope and Willett. *Trans.*, **103**, 1258 (1913).  
*m*-Nitrobenzeneazodimethylaniline. Baly, Tuck, and Marsden. *Trans.*, **97**, 1494 (1910).  
*o*-Nitrobenzeneazodimethylaniline. Baly, Tuck, and Marsden. *Trans.*, **97**, 1494 (1910).  
*m*-Nitrobenzeneazo-*a*-naphthol. Baly, Tuck, and Marsden. *Trans.*, **97**, 1494 (1910).  
*o*-Nitrobenzeneazo-*a*-naphthol. Baly, Tuck, and Marsden. *Trans.*, **97**, 1494 (1910).  
*p*-Nitrobenzeneazo-*a*-naphthol. Baly, Tuck, and Marsden. *Trans.*, **97**, 1494 (1910).  
*m*-Nitrobenzeneazophenol. Baly, Tuck, and Marsden. *Trans.*, **97**, 1494 (1910).  
*o*-Nitrobenzeneazophenol. Baly, Tuck, and Marsden. *Trans.*, **97**, 1494 (1910).  
*p*-Nitrobenzeneazophenol. Baly, Tuck, and Marsden. *Trans.*, **97**, 1494 (1910).  
 ,, Pope and Willett. *Trans.*, **103**, 1258 (1913).  
*m*-Nitrobenzenediazoethylamino-*p*-nitrobenzene. Smith and Watts. *Trans.*, **97**, 562 (1910).  
*p*-Nitrobenzenediazoethylamino-*p*-nitrobenzene. Smith and Watts. *Trans.*, **97**, 562 (1910).  
*p*-Nitrobenzenediazohydroxide. Hantzsch and Lifschitz. *Ber.*, **45**, 3011 (1912).  
 ,, methyl ether. Hantzsch and Lifschitz. *Ber.*, **45**, 3011 (1912).  
 Nitrobenzenediazo- $\psi$ -semicarbazinocamphor. Forster. *Trans.*, **89**, 222 (1906).  
*p*-Nitrobenzenediazonium chloride. Hantzsch and Lifschitz. *Ber.*, **45**, 3011 (1912).  
*p*-Nitrobenzenemethylnitrosoamine. Hantzsch and Lifschitz. *Ber.*, **45**, 3011 (1912).  
*p*-Nitrobenzenenitrosoamine. Hantzsch and Lifschitz. *Ber.*, **45**, 3011 (1912).  
*m*-Nitrobenzenesulphonic acid. Baly and Rice. *Trans.*, **103**, 2085 (1913).  
*m*-Nitrobenzoic acid. Purvis. *Trans.*, **107**, 966 (1915).  
*o*-Nitrobenzoic acid. Purvis. *Trans.*, **107**, 966 (1915).  
*p*-Nitrobenzoic acid. Hewitt, Pope, and Willett. *Trans.*, **101**, 1770 (1912).  
 ,, Purvis. *Trans.*, **107**, 966 (1915).  
*p*-Nitrobenzylideneaminoazobenzene. Pope and Willett. *Trans.*, **103**, 1258 (1913).  
*p*-Nitrobenzyl cyanide. Lifschitz and Jenner. *Ber.*, **48**, 1730 (1915).  
*m*-Nitrobenzylideneaniline. Baly, Tuck, and Marsden. *Trans.*, **97**, 571 (1910).  
*o*-Nitrobenzylideneaniline. Baly, Tuck, and Marsden. *Trans.*, **97**, 571 (1910).  
*p*-Nitrobenzylideneaniline. Baly, Tuck, and Marsden. *Trans.*, **97**, 571 (1910).  
 Nitrocamphane. Lowry and Desch. *Trans.*, **95**, 807 (1909).  
 Nitrocamphor. Lowry and Desch. *Trans.*, **95**, 807 (1909).  
 Nitrocamphoranhydride. Lowry and Desch. *Trans.*, **95**, 807 (1909).  
 Nitrocarbamide. Baly and Desch. *Trans.*, **93**, 1747 (1908).  
*m*-Nitrocinnamic acid. Purvis. *Trans.*, **107**, 966 (1915).  
 ,, ethyl ester. Baly, Tuck, and Marsden. *Trans.*, **97**, 571 (1910).  
*o*-Nitrocinnamic acid. Purvis. *Trans.*, **107**, 966 (1915).  
 ,, ethyl ester. Baly, Tuck, and Marsden. *Trans.*, **97**, 571 (1910).  
*p*-Nitrocinnamic acid. Purvis. *Trans.*, **107**, 966 (1915).  
 ,, ethyl ester. Baly, Tuck, and Marsden. *Trans.*, **97**, 571 (1910).  
 Nitro-*p*-cresetole. Baly, Tuck, and Marsden. *Trans.*, **97**, 571 (1910).  
 Nitro-*p*-cresol. Baly, Tuck, and Marsden. *Trans.*, **97**, 571 (1910).  
 Nitrocyanoacetamide. Hantzsch and Voigt. *Ber.*, **45**, 85 (1912).  
 Nitrocyclohexane. Zelinsky and Rosanoff. *Zeit. phys. Chem.*, **78**, 629 (1912).  
 Nitrodiacetyl-*p*-phenylenediamine. Morgan, Moss, and Porter. *Trans.*, **107**, 1296 (1915).  
 1-Nitro-3,5-diaminobenzene. Hantzsch. *Ber.*, **43**, 1662 (1910).  
*m*-Nitrodimethylaniline. Baly, Tuck, and Marsden. *Trans.*, **97**, 571 (1910).  
*p*-Nitrodimethylaniline. Baly, Tuck, and Marsden. *Trans.*, **97**, 571 (1910).  
 2-Nitrodimethyl-*p*-toluidine. Morgan and Clayton. *Trans.*, **99**, 1941 (1911).  
 3-Nitrodimethyl-*p*-toluidine. Morgan and Clayton. *Trans.*, **99**, 1941 (1911).  
 ,, Baly, Tuck, and Marsden. *Trans.*, **97**, 571 (1910).  
 Nitroethane. Baly and Desch. *Trans.*, **93**, 1747 (1908).  
 ,, Hantzsch and Voigt. *Ber.*, **45**, 85 (1912).  
 ,, Zelinsky and Rosanoff. *Zeit. phys. Chem.*, **78**, 629 (1912).  
 Nitrofluorene. Baly, Tuck, and Marsden. *Trans.*, **97**, 571 (1910).  
 Nitroform. Hedley. *Ber.*, **41**, 1195 (1908).

- Nitroform. Hantzsch and Voigt. Ber., 45, 85 (1912).  
 ,, Harper and Macbeth. Trans., 107, 87 (1915).  
 Nitroguanidine. Baly and Desch. Trans., 93, 1747 (1908).  
 Nitrohydroxystilbene. Hewitt, Lewcock, and Pope. Trans., 101, 604 (1912).  
*chromo*Nitrolic acid. Hantzsch and Kanasirski. Ber., 42, 889 (1909).  
*iso*Nitrolic acid. Hantzsch and Kanasirski. Ber., 42, 889 (1909).  
 Nitromalonic acid, ethyl ester. Hantzsch and Voigt. Ber., 45, 85 (1912).  
 ,, salts. Hantzsch and Voigt. Ber., 45, 85 (1912).  
 Nitromesitylene. Baly, Tuck, and Marsden. Trans., 97, 571 (1910).  
 Nitromethane. Baly and Desch. Trans., 93, 1747 (1908).  
 ,, Hedley. Ber., 41, 1195 (1908).  
 ,, Hantzsch and Voigt. Ber., 45, 85 (1912).  
 ,, Zelinsky and Rosanoff. Zeit. phys. Chem., 78, 629 (1912).  
 ,, Purvis and McClelland. Trans., 103, 1088 (1913).  
 Nitromethoxystilbene. Hewitt, Lewcock, and Pope. Trans., 101, 604 (1912).  
 3-Nitromethylaceto-*p*-toluidide. Baly, Tuck, and Marsden. Trans., 97, 571 (1910).  
 3-Nitro-*p*-methyltoluidine. Baly, Tuck, and Marsden. Trans., 97, 571 (1910).  
 ,, Morgan, Jobling, and Barnett. Trans., 101, 1209 (1912).  
 $\alpha$ -Nitronaphthalene. Baly, Tuck, and Marsden. Trans., 97, 571 (1910).  
 ,, Purvis. Trans., 101, 1315 (1912).  
 $\beta$ -Nitronaphthalene. Baly, Tuck, and Marsden. Trans., 97, 571 (1910).  
 ,, Purvis. Trans., 101, 1315 (1912).  
 $\alpha$ -Nitro- $\beta$ -naphthylamine. Purvis. Trans., 101, 1315 (1912).  
*m*-Nitrophenetole. Baly, Tuck, and Marsden. Trans., 97, 571 (1910).  
*o*-Nitrophenetole. Baly, Tuck, and Marsden. Trans., 97, 571 (1910).  
*p*-Nitrophenetole. Baly, Tuck, and Marsden. Trans., 97, 571 (1910).  
*m*-Nitrophenol. Hartley and Huntington. Phil. Trans., 170, I, 257 (1879).  
 ,, Baly, Edwards, and Stewart. Trans., 89, 514 (1906).  
 ,, Baly, Tuck, and Marsden. Trans., 97, 571 (1910).  
*o*-Nitrophenol. Hartley and Huntington. Phil. Trans., 170, I, 257 (1879).  
 ,, Baly, Edwards, and Stewart. Trans., 89, 514 (1906).  
 ,, Baly, Tuck, and Marsden. Trans., 97, 571 (1910).  
 ,, Purvis and McClelland. Trans., 103, 1088 (1913).  
 ,, Wright. Trans., 105, 669 (1914).  
*p*-Nitrophenol. Hartley and Huntington. Phil. Trans., 170, I, 257 (1879).  
 ,, Baly, Edwards, and Stewart. Trans., 89, 514 (1906).  
 ,, Baly, Tuck, and Marsden. Trans., 97, 571 (1910).  
 ,, Hantzsch and Voigt. Ber., 45, 85 (1912).  
 ,, Bortini. Zeit. phys. Chem., 87, 104 (1914).  
 ,, Wright. Trans., 105, 669 (1914).  
*p*-Nitrophenylacetic acid, ethyl ester. Hewitt, Pope, and Willett. Trans., 101, 1770 (1912).  
 ,, ,, sodium salt. Hewitt, Pope, and Willett. Trans., 101, 1770 (1912).  
*p*-Nitrophenylacetone. Hewitt, Pope, and Willett. Trans., 101, 1770 (1912).  
 Nitro-*p*-phenylenediamine. Morgan, Moss, and Porter. Trans., 107, 1296 (1915).  
*p*-Nitrophenylhydrazine. Baly and Tuck. Trans., 89, 982 (1906).  
*m*-Nitrophenylnitromethane. Hedley. Ber., 41, 1195 (1908).  
*o*-Nitrophenylnitromethane. Hedley. Ber., 41, 1195 (1908).  
*p*-Nitrophenylnitromethane. Hedley. Ber., 41, 1195 (1908).  
 Nitropropane. Zelinsky and Rosanoff. Zeit. phys. Chem., 78, 629 (1912).  
*sec*-Nitropropane. Zelinsky and Rosanoff. Zeit. phys. Chem., 78, 629 (1912).  
 Nitroquinol dimethyl ether. Hantzsch and Staiger. Ber., 41, 1204 (1908).  
 ,, ,, Baly, Tuck, and Marsden. Trans., 97, 571 (1910).  
 ,, ,, Baly and Rice. Trans., 101, 1475 (1912).  
 Nitrosoacetanilide. Hantzsch and Lifschitz. Ber., 45, 3011 (1912).  
*iso*Nitrosoacetic acid. Baly, Marsden, and Stewart. Trans., 89, 966 (1906).  
 ,, ,, ethyl ester. Baly, Marsden, and Stewart. Trans., 89, 966 (1906).  
*iso*Nitrosoacetone. Baly, Marsden, and Stewart. Trans., 89, 966 (1906).  
*iso*Nitrosoacetylacetone. Baly, Marsden, and Stewart. Trans., 89, 966 (1906).  
 ,, Lifschitz. Ber., 46, 3233 (1913).  
 Nitrosobenzene. Baly, Edwards, and Stewart. Trans., 89, 514 (1906).

- Nitrosobenzene. Baly and Desch. Trans., **93**, 1747 (1908).  
*tert*-Nitrosobutane. Baly and Desch. Trans., **93**, 1747 (1908).  
*iso*Nitrosodibenzoylmethane. Lifschitz. Ber., **46**, 3233 (1913).  
*iso*Nitrosocamphor. Baly, Marsden, and Stewart. Trans., **89**, 966 (1906).  
 „ „ *o*-methyl ether. Baly, Marsden, and Stewart. Trans., **89**, 966 (1906).  
*p*-Nitrosodimethylaniline. Hartley. Trans., **85**, 1010 (1904).  
*iso*Nitrosodimethyldihydroresorcin. Lifschitz. Ber., **46**, 3233 (1913).  
*iso*Nitrosomalonic acid, ethyl ester. Baly, Marsden, and Stewart. Trans., **89**, 966 (1906).  
*iso*Nitrosomethylacetone. Baly, Marsden, and Stewart. Trans., **89**, 966 (1906).  
 Nitrosomethylurethane. Hantzsch and Lifschitz. Ber., **45**, 3011 (1912).  
*p*-Nitrosophenol. Hartley, Dobbie, and Lauder. Brit. Ass. Report, 1902, 107.  
 „ „ Baly, Edwards, and Stewart. Trans., **89**, 514 (1906).  
*iso*Nitrosophenylmethylpyrazolone. Lifschitz. Ber., **47**, 1068 (1914).  
 Nitrosopiperidine. Purvis. Trans., **103**, 2283 (1913).  
*tert*-Nitrosoisopropylacetone. Baly and Desch. Trans., **93**, 1747 (1908).  
 Nitrososulphonic acid, copper salt. Baly and Desch. Trans., **93**, 1747 (1908).  
 Nitrosourethane. Baly and Desch. Trans., **93**, 1747 (1908).  
 Nitrostilbene. Hewitt, Lewcock, and Pope. Trans., **101**, 604 (1912).  
 $\omega$ -Nitrostyrene. Baly and Desch. Trans. **93**, 1747 (1908).  
*m*-Nitrotoluene. Baly, Tuck, and Marsden. Trans., **97**, 571 (1910).  
 „ „ Purvis and McClelland. Trans., **103**, 1088 (1913).  
*o*-Nitrotoluene. Baly, Tuck, and Marsden. Trans., **97**, 571 (1910).  
 „ „ Purvis and McClelland. Trans., **103**, 1088 (1913).  
*p*-Nitrotoluene. Baly, Tuck, and Marsden. Trans., **97**, 571 (1910).  
 „ „ Purvis and McClelland. Trans., **103**, 1088 (1913).  
 3-Nitro-*p*-toluidine. Baly, Tuck, and Marsden. Trans., **97**, 571 (1910).  
 4-Nitro-2.5-tolylenediamine. Morgan, Moss, and Porter. Trans., **107**, 1296 (1915).  
 Nitrourethane. Baly and Desch. Trans., **93**, 1747 (1908).  
 3-Nitro-*o*-xylene. Baly, Tuck, and Marsden. Trans., **97**, 571 (1910).  
 4-Nitro-*o*-xylene. Baly, Tuck, and Marsden. Trans., **97**, 571 (1910).
- O
- Octane. Hartley and Huntington. Phil. Trans., **170**, I. 257 (1879).  
*n*-Octyl alcohol. Hartley and Huntington. Phil. Trans., **170**, I. 257 (1879).  
 „ „ Massol and Faucon. Bull. Soc. Chim., **11**, 931 (1912).  
*iso*Octyl alcohol. Hartley. Trans., **39**, 153 (1881).  
 Oxalic acid. Hartley and Huntington. Phil. Trans., **170**, I. 257 (1879).  
 „ „ Magini. Nuovo Cim., **6**, 343 (1903).  
 „ „ Bielecki and Henri. Compt. rend., **155**, 456 (1912); Ber., **45**, 2819 (1912); **46**, 2596 (1913); **47**, 1690 (1914).  
 „ „ Hantzsch and Scharf. Ber., **46**, 3570 (1913).  
 „ „ Wright. Trans., **103**, 528 (1913); **105**, 669 (1914).  
 „ „ salts. Hantzsch and Scharf. Ber., **46**, 3570 (1913).  
 „ „ Wright. Trans., **103**, 528 (1913); **105**, 669 (1914).  
 Oxaloacetic acid, ethyl ester. Baly and Desch. Trans., **87**, 766 (1905).  
 „ „ and salts. Hantzsch. Ber., **48**, 1407 (1915).  
 Oxalosuccinonitrile. Gelbke. Phys. Zeit., **13**, 584 (1912).  
 Oxaluric acid. Soret. Arch. des Sciences, **10**, 429 (1883).  
 Oximidoxazolone. Hantzsch and Heilbron. Ber., **43**, 68 (1910).  
 Oxindonecarboxylic acid, ethyl ester. Hantzsch. Zeit. phys. Chem., **84**, 321 (1913).  
*m*-Oxyanthraquinone. Meyer and Fischer. Ber., **46**, 85 (1913).  
 Oxyazobenzene. See Benzeneazophenol.  
*m*-Oxybenzoic acid. Hartley. Trans., **53**, 641 (1888).  
 „ „ Magini. Atti R. Accad. Lincei, **12**, ii. 87 (1903); J. Chim. phys., **2**, 410 (1904).  
 „ „ Ley and v. Engelhardt. Zeit. phys. Chem., **74**, 1 (1910).  
 „ „ sodium salt. Ley and v. Engelhardt. Zeit. phys. Chem., **74**, 1 (1910).  
*o*-Oxybenzoic acid. Hartley and Huntington. Phil. Trans., **170**, i. 257 (1879).  
 „ „ Hartley. Trans., **53**, 641 (1883).

- o*-Oxybenzoic acid. Magini. Atti R. Accad. Lincei, **12**, ii. 87 (1903); J. Chim. phys., **2**, 410 (1904).  
 ,, ,, Wright. Trans., **103**, 528 (1913).  
 ,, ,, methyl ester. Ley and v. Engelhardt. Zeit. phys. Chem., **74**, 1 (1910).  
 ,, ,, sodium salt. Wright. Trans., **103**, 528 (1913); **105**, 669 (1914).  
*p*-Oxybenzoic acid. Hartley. Trans., **53**, 641 (1888).  
 ,, ,, Magini. Atti R. Accad. Lincei, **12**, ii. 87 (1903); J. Chim. phys., **2**, 410 (1904).  
 ,, ,, sodium salt. Ley and v. Engelhardt. Zeit. phys. Chem., **74**, 1 (1910).  
 ,, ,, Wright. Trans., **105**, 669 (1914).  
*o*-Oxycarbanil. Hartley, Dobbie, and Paliatseas. Trans., **87**, 839 (1900).  
 ,, ethyl ethers. Hartley, Dobbie, and Paliatseas. Trans., **87**, 839 (1900).  
 Oxydiphenylphthalide. Meyer and Fischer. Ber., **44**, 1944 (1911); **46**, 70 (1913).  
 Oxyfumaric acid. Hantzsch. Ber., **48**, 1407 (1915).  
 Oxyhydrastinine. Dobbie and Lauder. Trans., **83**, 605 (1903).  
 ,, Hartley, Dobbie, and Lauder. Brit. Ass. Report, 1903, 126.  
 Oxynarcotine. Hartley. Phil. Trans., **176**, 471 (1885).  
 3-Oxyphenazothionium chloride. Eckert and Pummerer. Zeit. phys. Chem., **87**, 599 (1914).  
 Oxyphenylphthalide. Meyer and Fischer. Ber., **44**, 1944 (1911), **46**, 70 (1913).  
*p*-Oxytriphenylmethane. Meyer and Fischer. Ber., **46**, 70 (1913).

## P

- Papaverine. Hartley. Phil. Trans., **176**, 471 (1885).  
 ,, Dobbie and Lauder. Trans., **83**, 605 (1903).  
 ,, Hartley, Dobbie, and Lauder. Brit. Ass. Report, 1903, 126.  
 Pararosaniline. Baker. Trans., **91**, 1490 (1907).  
 ,, Hantzsch. Ber., **46**, 1537 (1913).  
 Pentachloropyridine. Baker and Baly. Trans., **91**, 1122 (1907).  
 ,, Purvis. Trans., **103**, 2283 (1913).  
 1.2.4.5.8-Pentahydroxyanthraquinone. Meek and Watson. Trans., **109**, 544 (1916).  
 Pentamethylacetone. Henderson, Henderson, and Heilbron. Ber., **47**, 876 (1914).  
 $\alpha$ -Phellandrene. Hantzsch. Ber., **45**, 553 (1912).  
 ,, Stark, Steubing, Enklaar, and Lipp. Jahrb. Radioak., **10**, 139 (1913).  
 $\beta$ -Phellandrene. Hantzsch. Ber., **45**, 553 (1912).  
 ,, Stark, Steubing, Enklaar, and Lipp. Jahrb. Radioak., **10**, 139 (1913).  
 Phenanthrene. Hartley. Trans., **39**, 153 (1881).  
 ,, Elston. Astrophys. Journ., **25**, 155 (1907).  
 ,, Baly and Tuck. Trans., **93**, 1902 (1908).  
 ,, Gompel and Henri. Compt. rend., **157**, 1422 (1913).  
 Phenanthrenequinone. Baly and Stewart. Trans., **89**, 502 (1906).  
 Phenanthridine methiodide. Tinkler. Trans., **89**, 856 (1906).  
 Phenazine. Hantzsch. Ber., **49**, 511 (1916).  
*o*-Phenetidine. Purvis. Trans., **107**, 660 (1915).  
*p*-Phenetidine. Purvis. Trans., **107**, 660 (1915).  
 Phenetole. Baly and Collie. Trans., **87**, 1332 (1905).  
 ,, Baly and Ewbank. Trans., **87**, 1347 (1905).  
 ,, Purvis. Trans., **107**, 660 (1915).  
 Phenetoleazofornamide. Heilbron and Henderson. Trans., **103**, 1404 (1913).  
 Phenol. Hartley and Huntington. Phil. Trans., **170**, I. 257 (1879).  
 ,, Hartley, Dobbie, and Lauder. Trans., **81**, 929 (1902).  
 ,, Baly and Ewbank. Trans., **87**, 1347 (1905).  
 ,, Ley and v. Engelhardt. Zeit. phys. Chem., **74**, 1 (1910).  
 ,, Purvis and McClelland. Trans., **103**, 1088 (1913).  
 ,, Wright. Trans., **103**, 528 (1913); **105**, 669 (1914).  
 ,, Witte. Zeit. wiss. Phot., **14**, 347 (1915).  
 Phenolphthalein. Meyer and Hantzsch. Ber., **40**, 3479 (1907).  
 ,, Meyer and Marx. Ber., **40**, 3603 (1907); **41**, 2446 (1908).

- Phenolphthalein. Meyer and Fischer. Ber., **44**, 1944 (1911); **46**, 70 (1913).  
 „ dimethyl ether. Meyer and Hantzsch. Ber., **40**, 3479 (1907).  
 Phenosafranin chloride. Balls, Hewitt, and Newman. Trans., **101**, 1840 (1912).  
 Phenoxycetic acid, ethyl ester. Baly and Collie. Trans., **87**, 1322 (1905).  
 Phenyl acetate. Crymble, Stewart, Wright, and Glendinning. Trans., **99**, 451 (1911).  
 Phenyl benzyl ether. Purvis and McClelland. Trans., **101**, 1514 (1912).  
 „ „ „ Purvis. Trans., **105**, 590 (1914).  
 Phenyl benzyl ketone. Purvis and McClelland. Trans., **101**, 1514 (1912).  
 Phenyl carbonate. Purvis, Jones, and Tasker. Trans., **97**, 2287 (1910).  
 Phenyl diphenylcarbamate. Purvis. Trans., **105**, 1372 (1914).  
 Phenyl dithiocarbonate. Purvis, Jones, and Tasker. Trans., **97**, 2287 (1910).  
 Phenyl dithioxalate. Purvis, Jones, and Tasker. Trans., **97**, 2287 (1910).  
 Phenyl ethyl ketone. Baly and Collie. Trans., **87**, 1332 (1905).  
 Phenyl mercaptan. Fox and Pope. Trans., **103**, 1263 (1913).  
 Phenyl oxalate. Purvis, Jones, and Tasker. Trans., **97**, 2287 (1910).  
 Phenyl *o*-oxybenzoate. Ley and v. Engelhardt. Zeit. phys. Chem., **74**, 1 (1910).  
 Phenyl styryl ketone phenylsemicarbazone. Heilbron and Wilson. Trans., **103**, 1504 (1913).  
 Phenyl styryl ketone semicarbazone. Heilbron and Wilson. Trans., **101**, 1482 (1912).  
 Phenyl thioncarbonate. Purvis, Jones, and Tasker. Trans., **97**, 2287 (1910).  
 Phenyl trithiocarbonate. Purvis, Jones, and Tasker. Trans., **97**, 2287 (1910).  
 Phenylacetic acid. Baly and Collie. Trans., **87**, 1332 (1905).  
 „ „ Purvis. Trans., **107**, 966 (1915).  
 „ „ Baly and Tryhorn. Trans., **107**, 1058 (1915).  
 „ „ ethyl ester. Baly and Collie. Trans., **87**, 1332 (1905).  
 „ „ „ „ Baly and Tryhorn. Trans., **107**, 1058 (1915).  
 „ „ sodium salt. Ley and v. Engelhardt. Zeit. phys. Chem., **74**, 1 (1910).  
 „ „ „ „ Hewitt, Pope, and Willett. Trans., **101**, 1770 (1912).  
 „ „ „ „ Wright. Trans., **103**, 528 (1913).  
 Phenylacetonitrile. Hewitt, Pope, and Willett. Trans., **101**, 1770 (1912).  
 „ Purvis. Trans., **107**, 496 (1915).  
 „ Baly and Tryhorn. Trans., **107**, 1058 (1915).  
 Phenylacetylene. Ley and v. Engelhardt. Zeit. phys. Chem., **74**, 1 (1910).  
 Phenylacridine. Hantzsch. Ber., **44**, 1783 (1911).  
 „ methiodide. Dobbie and Tinkler. Trans., **87**, 269 (1906).  
 Phenylacridonium sulphate. Hantzsch. Ber., **44**, 1783 (1911).  
 Phenylaminoacetic acid. Ley and v. Engelhardt. Zeit. phys. Chem., **74**, 1 (1910).  
 „ „ sodium salt. Ley and v. Engelhardt. Zeit. phys. Chem., **74**, 1 (1910).  
 Phenylaminochlorophenylphenazonium chloride. Balls, Hewitt, and Newman. Trans., **101**, 1840 (1912).  
 Phenylaminonaphthylaminochlorophenylphenazonium chloride. Balls, Hewitt, and Newman. Trans., **101**, 1840 (1912).  
 Phenylaminonaphthylaminophenylphenazonium chloride. Balls, Hewitt, and Newman. Trans., **101**, 1840 (1912).  
 Phenylazodimethylhydroresorcin. Lifschitz. Ber., **47**, 1401 (1914).  
 „ enol ether. Lifschitz. Ber., **47**, 1401 (1914).  
 Phenylbenzoylacetylene. Stobbe and Ebert. Ber., **44**, 1289 (1911).  
 Phenylcyanonitromethane. Hantzsch and Voigt. Ber., **45**, 85 (1912).  
 Phenyl-2,4-dinitroaniline. Hantzsch. Ber., **43**, 1662 (1910).  
 Phenyl dinitromethane. Hedley. Ber., **41**, 1195 (1908).  
 „ Harper and Macbeth. Trans., **107**, 87 (1915).  
*p*-Phenylenediamine. Purvis. Trans., **105**, 590 (1914).  
 Phenylglyoxal-methylsazone. Baly, Tuck, Marsden, and Gazdar. Trans., **91**, 1572 (1907).  
 Phenylglyoxal-sazone. Baly, Tuck, Marsden, and Gazdar. Trans., **91**, 1572 (1907).  
 Phenylglyoxalphenylsazone. Baly, Tuck, Marsden, and Gazdar. Trans., **91**, 1572 (1907).  
 Phenylhydrazine. Baly and Tuck. Trans., **89**, 982 (1906).  
 8-Phenylindoneacetic acid. Stobbe. Ber., **48**, 441 (1915).  
 7-Phenylindoneacetic acid. Stobbe. Ber., **48**, 441 (1915)

- $\gamma$ -Phenylindoneacetic acid methyl ester. Stobbe. Ber., **48**, 441 (1915).  
 Phenylmethylacridine cyanide. Tinkler. Trans., **89**, 856 (1906).  
 Phenylmethylacridol. Dobbie and Tinkler. Trans., **87**, 269 (1905).  
 Phenylmethylhydrazodimethylhydroresorcin. Lifschitz. Ber., **47**, 1401 (1914).  
 Phenylmethylnitrosoamine. Dobbie and Tinkler. Trans., **87**, 273 (1905).  
     "                    Baly and Desch. Trans., **93**, 1747 (1908).  
 Phenylnitromethane. Hantzsch and Voigt. Ber., **45**, 85 (1912).  
     "                    Zelinsky and Rosanoff. Zeit. phys. Chem., **78**, 629 (1912).  
 Phenylpicramide. Hantzsch. Ber., **43**, 1662 (1910).  
     "                    Hantzsch and Lister. Ber., **43**, 1685 (1910).  
 4-Phenylpiperidine. Purvis. Trans., **103**, 2283 (1913).  
 Phenylpropionic acid. Stewart. Trans., **91**, 199 (1907).  
     "                    Ley and v. Engelhardt. Zeit. phys. Chem., **74**, 1 (1910).  
     "                    Stobbe and Ebert. Ber., **44**, 1289 (1911).  
     "                    Purvis. Trans., **107**, 966 (1915).  
 $\beta$ -Phenylpropionic acid. Baly and Collie. Trans., **87**, 1332 (1905).  
     "                    Stewart. Trans., **91**, 199 (1907).  
     "                    Ley and v. Engelhardt. Zeit. phys. Chem., **74**, 1 (1910).  
     "                    Stobbe and Ebert. Ber., **44**, 1289 (1911).  
     "                    Wright. Trans., **103**, 528 (1913).  
     "                    Baly and Tryhorn. Trans., **107**, 1058 (1915).  
     "                    sodium salt. Wright. Trans., **103**, 528 (1913).  
 4-Phenylpyridine. Purvis. Trans., **103**, 2283 (1913).  
 Phenylthiazime. Pummerer, Eckert, and Gassner. Ber., **47**, 1494 (1914).  
     "                    hydrochloride. Eckert and Pummerer. Zeit. phys. Chem., **87**, 599  
     (1914).  
 4-Phenyl-5-*p*-tolylpyrrolinophenazine. Purvis. Trans., **97**, 2535 (1910).  
 Phenyltrimethylammonium salts. Ley and Ulrich. Ber., **42**, 3440 (1909).  
 Phenyl-2,4-xylylmethane. Purvis and McClelland. Trans., **101**, 1514 (1912).  
 Phlorizine. Hartley and Huntington. Phil. Trans., **170**, I. 257 (1879).  
 Phloroglucinol. Hartley, Dobbie, and Lauder. Trans., **81**, 929 (1902).  
     "                    Hedley. Trans., **89**, 730 (1906).  
     "                    trimethyl ether. Hartley, Dobbie, and Lauder. Trans., **81**, 929 (1902).  
 Phorone. Baker and Baly. Trans., **91**, 1122 (1907).  
     "                    Purvis and McClelland. Trans., **103**, 433 (1913).  
     "                    Bielecki and Henri. Ber., **47**, 1690 (1914); Compt. rend., **158**, 567, 1114  
     (1914).  
*m*-Phthalaldehyde. Purvis. Trans., **105**, 2482 (1914).  
*o*-Phthalaldehyde. Purvis. Trans., **105**, 2482 (1914).  
*p*-Phthalaldehyde. Purvis. Trans., **105**, 2482 (1914).  
 Phthalic acid. Hartley and Huntington. Phil. Trans., **170**, I. 257 (1879).  
     "                    Magini. J. Chim. phys., **2**, 410 (1904).  
     "                    Hartley and Hedley. Trans., **91**, 314 (1907).  
*iso*Phthalic acid. Hartley and Hedley. Trans., **91**, 314 (1907).  
     "                    Magini. J. Chim. phys., **2**, 410 (1904).  
     "                    potassium salt. Hartley and Hedley. Trans., **91**, 314 (1907).  
 Phthalic anhydride. Hartley and Hedley. Trans., **91**, 314 (1907).  
 Phthalide. Ley and v. Engelhardt. Zeit. phys. Chem., **74**, 1 (1910).  
 Phthalimide. Hartley and Hedley. Trans., **91**, 314 (1907).  
 Phthalyl chloride. Scheiber. Ber., **46**, 2366 (1913).  
 Picene. Homer and Purvis. Trans., **93**, 1319 (1908); **97**, 1155 (1910).  
 Picoline. Hartley. Trans., **41**, 45 (1882); **47**, 685 (1885).  
     "                    Baker and Baly. Trans., **91**, 1122 (1907).  
     "                    Purvis. Trans., **95**, 294 (1909); **97**, 692 (1910).  
 Picramic acid. Meldola and Hewitt. Trans., **103**, 876 (1913).  
*iso*Picramic acid. Meldola and Hewitt. Trans., **103**, 876 (1913).  
 Picramide. Morgan, Jobling, and Barnett. Trans., **101**, 1209 (1912).  
 Picric acid. Buttler and Hewitt. Trans., **95**, 1755 (1909).  
     "                    Baly and Rice. Trans., **103**, 2085 (1913).  
     "                    Wright. Trans., **103**, 528 (1913); **105**, 669 (1914).  
     "                    Bortini. Zeit. phys. Chem., **87**, 104 (1914).  
     "                    potassium salt. Franchimont and Bacher. Proc. K. Akad. Amsterdam,  
     **17**, 647 (19

- Picric acid sodium salt. Wright. Trans., **103**, 528 (1913); **105**, 669 (1914).
- Picrotoxine. Hartley. Phil. Trans., **176**, 471 (1885).
- Picrylmethylacetamide. Franchimont and Backer. Proc. K. Akad. Amsterdam, **17**, 647 (1914).
- Picrylmethylamide. Franchimont and Backer. Rec. Trav. Chim., **32**, 325 (1913); Proc. K. Akad., Amsterdam, **17**, 647 (1914).
- Picrylmethylaminoformic acid, esters of. Franchimont and Backer. Proc. K. Akad., Amsterdam, **17**, 647 (1914).
- Picrylmethylnitroamine. Franchimont and Backer. Rec. Trav. Chim., **32**, 325 (1913).
- Picrylmethylnitrosoamine. Franchimont and Backer. Proc. K. Akad., Amsterdam, **17**, 647 (1914).
- Picrylphenylmethylamide. Franchimont and Backer. Proc. K. Akad., Amsterdam, **17**, 647 (1914).
- Pinacolone. Stewart and Baly. Trans., **89**, 489 (1906).
- „ Bielecki and Henri. Compt. rend., **156**, 1322 (1913); Ber., **46**, 3627 (1913).
- „ Henderson, Henderson, and Heilbron. Ber., **47**, 876 (1914).
- „ Stark and Lipp. Zeit. phys. Chem., **86**, 36 (1914).
- „ Rice. Proc. Roy. Soc., **91A**, 76 (1914).
- α*-Pinene. Hantzsch. Ber., **45**, 553 (1912).
- „ Stark, Steubing, Enklaar, and Lipp. Jahrb. Radioak., **10**, 139 (1913).
- Piperazine. Purvis. Trans., **103**, 2283 (1913).
- Piperic acid. Dobbie and Fox. Trans., **103**, 1193 (1913).
- Piperidine. Hartley. Trans., **47**, 685 (1885).
- „ Purvis. Trans., **97**, 692 (1910); **103**, 2283 (1913).
- Piperidinium nitrite. Harper and Macbeth. Trans., **107**, 87 (1915).
- Piperidoacetic acid, copper salt. Ley and Hegge. Ber., **48**, 70 (1915).
- Piperine. Hartley. Phil. Trans., **176**, 471 (1885).
- „ Dobbie and Fox. Trans., **103**, 1193 (1913).
- „ Purvis. Trans., **103**, 2283 (1913).
- Piperonalphenylhydrazone. Stobbe and Nowak. Ber., **46**, 2887 (1913).
- Piperonylic acid. Dobbie and Lauder. Trans., **83**, 605 (1903).
- „ Hartley, Dobbie, and Lauder. Brit. Ass. Report, 1903, 126.
- Propiolic acid, methyl ester. Bielecki and Henri. Ber., **46**, 2596 (1913).
- Propionaldehyde. Bielecki and Henri. Compt. rend., **155**, 456 (1912); Ber., **45**, 2819 (1912); **46**, 3627 (1913).
- „ Purvis and McClelland. Trans., **101**, 1810 (1912).
- Propionaldehydephenylhydrazone. Baly and Tuck. Trans., **89**, 982 (1906).
- Propionaldehydephenylmethylhydrazone. Baly and Tuck. Trans., **89**, 982 (1906).
- Propionamide. Bielecki and Henri. Compt. rend., **156**, 1860 (1913).
- „ Ley and Fischer. Zeit. anorg. Chem., **82**, 329 (1913).
- Propionic acid. Hartley and Huntington. Phil. Trans., **170**, I, 257 (1879).
- „ „ Bielecki and Henri. Compt. rend., **155**, 456, 1617 (1912); **156**, 550 (1913); Ber., **45**, 2819 (1912); **46**, 1304, 2596 (1913).
- „ „ Hantzsch and Scharf. Ber., **46**, 3570 (1913).
- „ „ Wright. Trans., **103**, 528 (1913); **105**, 669 (1914).
- „ „ metallic salts. Wright. Trans., **103**, 528 (1913); **105**, 669 (1914).
- Propionylcamphor. Lowry and Southgate. Trans., **97**, 905 (1910).
- Propyl acetate. Magini. Nuovo Cim., **6**, 343 (1903).
- „ „ Bielecki and Henri. Compt. rend., **155**, 456, 1617 (1912); **156** (1913); Ber., **45**, 2819 (1912); **46**, 1304 (1913).
- Propyl alcohol. Hartley and Huntington. Phil. Trans., **170**, I, 257 (1879).
- „ „ Drossbach. Ber., **35**, 1486 (1902).
- iso*Propyl alcohol. Hartley. Trans., **39**, 153 (1881).
- n*-Propyl alcohol. Bielecki and Henri. Compt. rend., **155**, 456 (1912); Ber., **45**, 2819 (1912); **46**, 2596 (1913).
- „ „ Massol and Faucon. Bull. Soc. Chim., **11**, 931 (1912).
- Propyl aldehyde. See Propionaldehyde.
- Propyl butyrate. Bielecki and Henri. Compt. rend., **156**, 550 (1913).
- Propyl dithiooxalate. Purvis, Jones, and Tasker. Trans., **97**, 2287 (1910).
- Propyl formate. Bielecki and Henri. Compt. rend., **155**, 1617 (1912); **156**, 550 (1913); Ber., **46**, 1304 (1913).



- Propyl propionate. Hartley and Huntington. *Phil. Trans.*, **170**, I. 257 (1879).  
 " " Bielecki and Henri. *Compt. rend.*, **156**, 550 (1913).  
 Propyl valerate. Hartley and Huntington. *Phil. Trans.*, **170**, I. 257 (1879).  
 Propylamine. Bielecki and Henri. *Compt. rend.*, **156**, 1860 (1913).  
 Propylbenzene. Baly and Collie. *Trans.*, **87**, 1332 (1905).  
 Propylnitroamine. Franchimont and Backer. *Trans.*, **101**, 2256 (1912).  
 Psychotrine. Dobbie and Fox. *Trans.*, **105**, 1639 (1914).  
 Pulegone. Crymble, Stewart, Wright, and Rea. *Trans.*, **99**, 1262 (1911).  
 Purpurine. Meyer and Fischer. *Ber.*, **46**, 85 (1913).  
 " Meek and Watson. *Trans.*, **109**, 544 (1916).  
 Pyridine. Hartley. *Trans.*, **47**, 685 (1885).  
 " Pauer. *Ann. der Phys.*, **61**, 363 (1897).  
 " Hartley and Dobbie. *Trans.*, **77**, 509 (1900).  
 " Magini. *Nuovo Cim.*, **6**, 343 (1903).  
 " Baker and Baly. *Trans.*, **91**, 1122 (1907).  
 " Hantzsch. *Ber.*, **44**, 1783 (1910).  
 " Purvis. *Trans.*, **97**, 692 (1910).  
 " Baly and Rice. *Trans.*, **103**, 91 (1913).  
 " Baly and Tryhorn. *Trans.*, **107**, 1121 (1915).  
 Pyridine dicarboxylic acids. Hartley. *Trans.*, **41**, 45 (1882).  
 Pyridinemethylbromide. Hantzsch. *Ber.*, **44**, 1783 (1911).  
 Pyridinemethylchloride. Hantzsch. *Ber.*, **44**, 1783 (1911).  
 Pyridinemethyliodide. Hantzsch. *Ber.*, **44**, 1783 (1911).  
 $\alpha$ -Pyridone. Baker and Baly. *Trans.*, **91**, 1122 (1907).  
 $\beta$ -Pyridone. Baker and Baly. *Trans.*, **91**, 1122 (1907).  
 $\gamma$ -Pyridone. Baker and Baly. *Trans.*, **91**, 1122 (1907).  
 Pyrocatechol. *See* Catechol.  
 Pyrocinchonimide. Ley and Fischer. *Ber.* **46**, 327 (1913).  
 Pyrogallol. Hartley and Huntington. *Phil. Trans.*, **170**, I. 257 (1879).  
 " Hartley, Dobbie, and Lauder. *Trans.*, **81**, 929 (1902).  
 " Hedley. *Trans.*, **89**, 730 (1906).  
 Pyrogallolbenzein. Medhi and Watson. *Trans.*, **107**, 1579 (1915).  
 Pyromeconic acid. Baly, Collie, and Watson. *Trans.*, **95**, 144 (1909).  
 Pyromucic acid. Hartley and Dobbie. *Trans.*, **73**, 598 (1898).  
 4-Pyrone. Baly, Collie, and Watson. *Trans.*, **95**, 144 (1909).  
 Pyronine-G. Watson and Meek. *Trans.*, **107**, 1567 (1915).  
 Pyrrole. Hartley and Dobbie. *Trans.*, **73**, 598 (1898).  
 " Hartley, Dobbie, and Lauder. *Trans.*, **81**, 929 (1902).  
 " Purvis. *Trans.*, **97**, 1648 (1910).  
 Pyruvaldehydeosazone. Baly, Tuck, Marsden, and Gazdar. *Trans.*, **91**, 1572 (1907).  
 Pyruvaldehydephenylhydrazone. Baly, Tuck, Marsden, and Gazdar. *Trans.*, **91**, 1572 (1907).  
 Pyruvaldehydephenylmethylhydrazone. Baly, Tuck, Marsden, and Gazdar. *Trans.*, **91**, 1572 (1907).  
 Pyruvic acid. Bielecki and Henri. *Compt. rend.*, **156**, 1322 (1913); **158**, 866 (1914); *Ber.*, **47**, 1690 (1914).

## Q

- Quinazarine. Meyer and Fischer. *Ber.*, **46**, 85 (1913).  
 " Meek and Watson. *Trans.*, **109**, 544 (1916).  
 Quinhydrone. Hartley and Leonard. *Trans.*, **95**, 34 (1909).  
 Quinidine. Hartley. *Phil. Trans.*, **176**, 471 (1885).  
 Quinine. Hartley. *Phil. Trans.*, **176**, 471 (1885).  
 " Dobbie and Lauder. *Trans.*, **83**, 605 (1903); **99**, 1254 (1911).  
 " Hartley, Dobbie, and Lauder. *Brit. Ass. Report*, 1903, 126.  
 " Dobbie and Fox. *Trans.*, **101**, 77 (1912).  
 Quinol. Hartley. *Trans.*, **53**, 641 (1888).  
 " Magini. *Atti R. Accad. Lincei*, **12**, ii, 87 (1903); *J. Chim. phys.*, **2**, 410 (1904).  
 " Baly and Ewbank. *Trans.*, **87**, 1347 (1905).  
 " Hartley and Leonard. *Trans.*, **95**, 34 (1909).  
 " Purvis and McClelland. *Trans.*, **103**, 1088 (1913).

- Quinol dimethyl ether. Baly and Ewbank. *Trans.*, **87**, 1347 (1905).  
 „ „ „ Baly and Rice. *Trans.*, **101**, 1475 (1912).  
 „ monomethyl ether. Baly and Ewbank. *Trans.*, **87**, 1347 (1905).  
 Quinoline. Hartley. *Trans.*, **41**, 45 (1882); **47**, 685 (1885).  
 „ Ley and v. Engelhardt. *Zeit. phys. Chem.*, **74**, 1 (1910).  
 „ Hantzsch. *Ber.*, **44**, 1783 (1911).  
 „ Purvis. *Trans.*, **97**, 1035 (1910).  
 „ Dobbie and Lauder. *Trans.*, **99**, 1254 (1911).  
*iso*Quinoline. Ley and v. Engelhardt. *Zeit. phys. Chem.*, **74**, 1 (1910).  
 Quinolineazo-8-hydroxyquinoline. Fox. *Trans.*, **97**, 1337 (1910).  
 Quinolineazophenol. Fox. *Trans.*, **97**, 1337 (1910).  
 Quinolinemethylchloride. Hantzsch. *Ber.*, **44**, 1783 (1911).  
 Quinolinemethyliodide. Hantzsch. *Ber.*, **44**, 1783 (1911).  
*iso*Quinolinemethyliodide. Hantzsch. *Ber.*, **44**, 1783 (1911).  
 „ Tinkler. *Trans.*, **101**, 1245 (1912).  
 Quinolinic acid. Scheiber and Knothe. *Ber.*, **45**, 2252 (1912).  
 „ „ chloride of. Scheiber and Knothe. *Ber.*, **45**, 2252 (1912).  
 „ „ dimethyl ester. Scheiber and Knothe. *Ber.*, **45**, 2252 (1912).  
 Quinoliphthalein. Meyer and Marx. *Ber.*, **40**, 3603 (1907); **41**, 2246 (1908).  
 „ Meyer and Fischer. *Ber.*, **44**, 1944 (1911).  
 Quinone. *See p*-Benzoquinone.

## R

- Racemic acid. Stewart. *Trans.*, **91**, 1537 (1907).  
 „ Bielecki and Henri. *Ber.*, **46**, 2596 (1913).  
 Resorcinol. Hartley. *Trans.*, **53**, 641 (1888).  
 „ Magini. *Atti R. Accad. Lincei*, **12**, ii. 87 (1903); *J. Chim. phys.*, **2**, 410 (1904).  
 „ Baly and Ewbank. *Trans.*, **87**, 1347 (1905).  
 „ dimethyl ether. Baly and Ewbank. *Trans.*, **87**, 1347 (1905).  
 „ „ Baly and Rice. *Trans.*, **101**, 1475 (1912).  
 „ monomethyl ether. Baly and Ewbank. *Trans.*, **67**, 1347 (1905).  
 Resorcinolbenzein. Medhi and Watson. *Trans.*, **107**, 1579 (1915).  
 Resorufin. Nichols and Merritt. *Phys. Rev.*, **31**, 376 (1910).  
 Rosaniline. Hartley. *Trans.*, **51**, 153 (1887).  
 Rose Bengal. Massol and Faucon. *Bull. Soc. Chim.*, **13**, 217 (1913).  
 „ van der Plaats. *Ann. der Phys.*, **47**, 429 (1915).  
 Rufigallol. Meek and Watson. *Trans.*, **109**, 544 (1916).

## S

- Safrole. Pflüger. *Phys. Zeit.*, **10**, 406 (1909).  
 „ Crymble, Stewart, Wright, and Glendinning. *Trans.*, **99**, 451 (1911).  
*iso*Safrole. Pflüger. *Phys. Zeit.*, **10**, 406 (1909).  
 „ Crymble, Stewart, Wright, and Glendinning. *Trans.*, **99**, 451 (1911).  
 Salicine. Hartley and Huntington. *Phil. Trans.*, **170**, 1, 257 (1879).  
 Salicylaldehyde. Tuck. *Trans.*, **95**, 1809 (1909).  
 „ Purvis. *Trans.*, **105**, 2482 (1914).  
 „ Baly and Tryhorn, **107**, 1121 (1915).  
 Salicylaldehydephenylmethylhydrazone. Tuck. *Trans.*, **95**, 1809 (1909).  
 Salicylic acid. *See o*-Oxybenzoic acid.  
 Sandalwood oil. Pflüger. *Phys. Zeit.*, **10**, 406 (1909).  
 Serine. Soret. *Arch. des Sciences*, **10**, 429 (1883).  
 Sodium benzene-*anti*-azotate. Hantzsch and Lifschitz. *Ber.*, **45**, 3011 (1912).  
 Solanine. Hartley. *Phil. Trans.*, **176**, 471 (1885).  
 Starch. Hartley. *Trans.*, **51**, 58 (1887).  
 Stilbene. Baly and Tuck. *Trans.*, **93**, 1902 (1908).  
 „ Crymble, Stewart, and Wright. *Ber.*, **43**, 1188 (1910).  
 „ Stobbe and Ebert. *Ber.*, **44**, 1289 (1911).  
 „ Hantzsch and Lifschitz. *Ber.*, **45**, 3011 (1912).  
 „ Hewitt, Lewcock, and Pope. *Trans.*, **101**, 604 (1912).  
 Strychnine. Hartley. *Phil. Trans.*, **176**, 471 (1885).

- Styrene. Baly and Desch. *Trans.*, **93**, 1747 (1908).  
 " Ley and v. Engelhardt. *Zeit. phys. Chem.*, **74**, 1 (1910).  
 " Stobbe and Ebert. *Ber.*, **44**, 1289 (1911).  
 Succinic acid. Stewart. *Trans.*, **91**, 199 (1907).  
 " " Crymble, Stewart, Wright, and Rea. *Trans.*, **99**, 1262 (1911).  
 " " Bielecki and Henri. *Compt. rend.*, **155**, 456 (1912); **157**, 372 (1913);  
*Ber.*, **45**, 2819 (1912); **46**, 2596 (1913); **47**, 1690 (1914).  
 " " Wright. *Trans.*, **103**, 528 (1913); **105**, 669 (1914).  
 " " sodium salts. Wright. *Trans.*, **103**, 528 (1913); **105**, 669 (1914).  
 Succinimide. Ley and Fischer. *Ber.*, **46**, 327 (1913); *Zeit. anorg. Chem.*, **82**, 329 (1913).  
*p*-Sulphobenzeneazodimethylaniline. Hantzsch. *Ber.*, **46**, 1537 (1913).  
*p*-Sulphobenzene diazohydroxide, salts of. Dobbie and Tinkler. *Trans.*, **87**, 273 (1905).  
*o*-Sulphobenzoic acid. Scheiber and Knothe. *Ber.*, **45**, 2252 (1912).  
 " " chloride. Scheiber and Knothe. *Ber.*, **45**, 2252 (1912).  
 Sylvestrene. Hantzsch. *Ber.*, **45**, 553 (1912).  
 " Stark, Stenbing, Enklaar, and Lipp. *Jahrb. Radioak.*, **10**, 139 (1913).

## T

- Tartaric acid. Magini. *J. Chim. phys.*, **2**, 410 (1904).  
 " " Stewart. *Trans.*, **91**, 1537 (1907).  
 " " Bielecki and Henri. *Ber.*, **46**, 2596 (1913).  
 Terephthalic acid. Hartley and Hedley. *Trans.*, **91**, 314 (1907).  
 " " Magini. *J. Chim. phys.*, **2**, 410 (1904).  
 " " potassium salt. Hartley and Hedley. *Trans.*, **91**, 314 (1907).  
 Terpinene. Crymble, Stewart, Wright, and Rea. *Trans.*, **99**, 1262 (1911).  
 Terpinolene. Crymble, Stewart, Wright, and Rea. *Trans.*, **99**, 1262 (1911).  
 Tetraacetylene. Baly, Collie, and Watson. *Trans.*, **95**, 144 (1909).  
 Tetraacetylmorphine. Hartley. *Phil. Trans.*, **176**, 471 (1885).  
 $\alpha$ -Tetrabromo-*p*-azophenol. Robertson. *Trans.*, **103**, 1472 (1913).  
 $\beta$ -Tetrabromo-*p*-azophenol. Robertson. *Trans.*, **103**, 1472 (1913).  
 Tetrabromophenolphthalein. Meyer and Marx. *Ber.*, **41**, 2446 (1908).  
 " Meyer and Fischer. *Ber.*, **44**, 1944 (1911).  
 Tetrachloro-2-aminopyridine. Purvis. *Trans.*, **103**, 2283 (1913).  
 2.3.4.5-Tetrachloropyridine. Baker and Baly. *Trans.*, **91**, 1122 (1907).  
 " Purvis. *Trans.*, **103**, 2283 (1913).  
 Tetrahydrobenzene. Hartley and Dobbie. *Trans.*, **77**, 846 (1900).  
 " Zelinsky and Gorsky. *Ber.*, **44**, 2312 (1911).  
 Tetrahydroberberine. Dobbie and Lauder. *Trans.*, **83**, 605 (1903).  
 " Hartley, Dobbie, and Lauder. *Brit. Ass. Report*, 1903, 126.  
 " Dobbie and Fox. *Trans.*, **105**, 1639 (1914).  
 1.2.3.4-Tetrahydronaphthalene. Baly and Tuck. *Trans.*, **93**, 1902 (1908).  
 " Leonard. *Trans.*, **97**, 1246 (1910).  
 1.2.5.8-Tetrahydronaphthalene. Baly and Tuck. *Trans.*, **93**, 1902 (1908).  
 Tetrahydropapaverine. Dobbie and Lauder. *Trans.*, **83**, 605 (1903).  
 " Hartley, Dobbie, and Lauder. *Brit. Ass. Report*, 1903, 126.  
 " Dobbie and Fox. *Trans.*, **105**, 1639 (1914).  
 Tetrahydroquinoline. Hartley. *Trans.*, **41**, 45 (1882); **47**, 685 (1885).  
 1.2.5.8-Tetrahydroxyanthraquinone. Meek and Watson. *Trans.*, **109**, 544 (1916).  
 Tetraiododichlorofluorescein, sodium salt. van der Plaats. *Ann. der Phys.*, **47**, 429 (1915).  
*mm'**pp'*-Tetramethoxy-2.6-diphenylpyrazine. Tutin and Caton. *Trans.*, **97**, 2524 (1910).  
 4.4'-Tetramethyldiaminobenzhydrol. Watson and Meek. *Trans.*, **107**, 1567 (1915).  
 4.4'-Tetramethyldiaminobenzophenone. Baly and Marsden. *Trans.*, **93**, 2108 (1908).  
 " Grandmougin and Favre-Ambrumyan. *Ber.*, **47**, 2127 (1914).  
 Tetramethylnaphthalene. Homer and Purvis. *Trans.*, **97**, 280 (1910).  
 Tetranaphthyl. Homer and Purvis. *Trans.*, **93**, 1319 (1908).  
 Tetranitromethane. Zelinsky and Rosanoff. *Zeit. phys. Chem.*, **78**, 629 (1913).  
 " Harper and Macbeth. *Trans.*, **107**, 87 (1915).  
 " Macbeth. *Trans.*, **107**, 1824 (1915).

- Tetraphenylquinodimethane. Heilbron and Henderson. *Trans.*, **103**, 1404 (1913).
- Tetraphenylsilicane. Purvis. *Trans.*, **105**, 1372 (1914).
- Tetraphenylthiopurpuric acid. Lifschitz. *Ber.*, **47**, 1068 (1914).
- Tetrazine. Koenigsberger and Vogt. *Phys. Zeit.*, **14**, 1269 (1913).
- Thebaine. Hartley. *Phil. Trans.*, **176**, 471 (1885).
- Theobromine. Hartley. *Trans.*, **87**, 1796 (1905).
- Thiazime. Pummerer, Eckert, and Gassner. *Ber.*, **47**, 1494 (1914).
- „ hydrochloride. Eckert and Pummerer. *Zeit. phys. Chem.*, **87**, 599 (1914).
- Thiazone. Pummerer, Eckert, and Gassner. *Ber.*, **47**, 1494 (1914).
- „ Eckert and Pummerer. *Zeit. phys. Chem.*, **87**, 599 (1914).
- Thioacetanilide. *May. Trans.*, **103**, 2272 (1913).
- Thioacetic acid. Hantzsch and Scharf. *Ber.*, **46**, 3570 (1913).
- „ ethyl ester. Hantzsch and Scharf. *Ber.*, **46**, 3570 (1913).
- „ potassium salt. Hantzsch and Scharf. *Ber.*, **46**, 3570 (1913).
- Thiobenzamide. Hantzsch and Scharf. *Ber.*, **46**, 3570 (1913).
- Thiobenzanilide. *May. Trans.*, **103**, 2272 (1913).
- Thiobenzoic acid. Hantzsch and Scharf. *Ber.*, **46**, 3570 (1913).
- „ methyl ester. Hantzsch and Scharf. *Ber.*, **46**, 3570 (1913).
- „ metallic salts. Hantzsch and Scharf. *Ber.*, **46**, 3570 (1913).
- Thiocarbamide. Macbeth, Stewart, and Wright. *Trans.*, **101**, 599 (1912).
- Thioncarbonic acid, ethyl ester. Purvis, Jones, and Tasker. *Trans.*, **97**, 2287 (1910).
- „ phenyl ester. Purvis, Jones, and Tasker. *Trans.*, **97**, 2287 (1910).
- Thionin. Eckert and Pummerer. *Zeit. phys. Chem.*, **87**, 599 (1914).
- „ Pummerer, Eckert, and Gassner. *Ber.*, **47**, 1494 (1914).
- Thionthiocarbonic acid, ethyl ester. Purvis, Jones, and Tasker. *Trans.*, **97**, 2287 (1910).
- Thionylmethylphenylhydrazine. Hutchison and Smiles. *Ber.*, **47**, 514 (1914).
- Thionylphenylhydrazine. Hutchison and Smiles. *Ber.*, **47**, 514 (1914).
- Thiooxalic acid, ethyl ester. Purvis, Jones, and Tasker. *Trans.*, **97**, 2287 (1910).
- Thiophene. Pauer. *Ann. der Phys.*, **61**, 363 (1897).
- „ Hartley and Dobbie. *Trans.*, **73**, 598 (1898).
- „ Purvis. *Trans.*, **97**, 1648 (1910).
- Thymol. Hartley and Huntington. *Phil. Trans.*, **170**, I. 257 (1879).
- „ Wright. *Trans.*, **105**, 669 (1914).
- „ sodium salt. Wright. *Trans.*, **105**, 669 (1914).
- Thymoquinone. Baly and Stewart. *Trans.*, **89**, 502 (1906).
- Tolane. Stobbe and Ebert. *Ber.*, **44**, 1289 (1911).
- m*-Toluylaldehyde. Purvis. *Trans.*, **105**, 2482 (1914).
- o*-Toluylaldehyde. Purvis. *Trans.*, **105**, 2482 (1914).
- p*-Toluylaldehyde. Purvis. *Trans.*, **105**, 2482 (1914).
- Toluene. Hartley and Huntington. *Phil. Trans.*, **170**, I. 257 (1879).
- „ Pauer. *Ann. der Phys.*, **61**, 363 (1897).
- „ Baly and Collie. *Trans.*, **87**, 1332 (1905).
- „ Grebe. *Zeit. wiss. Phot.*, **3**, 376 (1905).
- „ Hartley. *Phil. Trans.*, **208A**, 475 (1908); *Zeit. wiss. Phot.*, **6**, 299 (1908).
- „ v. Kowalski. *Bull. Akad. Sci., Cracovie*, **1A**, 17 (1910).
- „ Cremer. *Zeit. wiss. Phot.*, **10**, 349 (1912).
- „ Baly and Tryhorn. *Trans.*, **107**, 1058 (1915).
- „ Witte. *Zeit. wiss. Phot.*, **14**, 347 (1915).
- p*-Tolueneazocarbonylcoumaranone. Merriman. *Trans.*, **103**, 1845 (1913).
- p*-Tolueneazo-*p*-cresetole. Tuck. *Trans.*, **91**, 449 (1907).
- p*-Tolueneazo-*p*-cresol. Tuck. *Trans.*, **91**, 449 (1907).
- p*-Tolueneazodimethylamine. Hantzsch and Lifschitz. *Ber.*, **45**, 3011 (1912).
- Toluenediazo- $\psi$ -semicarbazinocamphor. Forster. *Trans.*, **89**, 222 (1906).
- o*-Toluenesulphonic acid. Scheiber and Knothe. *Ber.*, **45**, 2252 (1912).
- „ chloride. Scheiber and Knothe. *Ber.*, **45**, 2252 (1912).
- Toluene-*p*-sulphonyl-1,6-dinitro- $\beta$ -naphthylamine. Morgan, Jobling, and Barnett. *Trans.*, **101**, 1209 (1912).
- Toluene-*p*-sulphonylmethyl-1-nitro- $\beta$ -naphthylamine. Morgan, Jobling, and Barnett. *Trans.*, **101**, 1209 (1912).

- Toluene-*p*-sulphonyl-1-nitro- $\beta$ -naphthylamine. Morgan, Jobling, and Barnett. Trans., **101**, 1209 (1912).
- m*-Toluic acid. Perkin and Simonsen. Trans., **91**, 840 (1907).  
 " " Purvis. Trans., **107**, 966 (1915).
- o*-Toluic acid. Purvis. Trans., **107**, 966 (1915).
- r*-Toluic acid. Purvis. Trans., **107**, 966 (1915).
- $\psi$ -*m*-Toluic acid. Perkin and Simonsen. Trans., **91**, 840 (1907).
- m*-Toluidine. Hartley. Trans., **47**, 685 (1885).  
 " Baly and Ewbank. Trans., **87**, 1355 (1905).  
 " Purvis. Trans., **97**, 1546 (1910).
- o*-Toluidine. Hartley. Trans., **47**, 685 (1885).  
 " Baly and Ewbank. Trans., **87**, 1355 (1905).  
 " Purvis. Trans., **97**, 1546 (1910).  
 " azo-benzene. Hantzsch. Ber., **48**, 167 (1915).  
 " " sulphonic acid. Hantzsch. Ber., **48**, 167 (1915).
- p*-Toluidine. Hartley. Trans., **47**, 685 (1885).  
 " Baly and Ewbank. Trans., **87**, 1355 (1905).  
 " Purvis. Trans., **97**, 644 (1910).  
 " acetaldehyde condensation compound. Purvis. Trans., **97**, 644 (1910).
- $\alpha$ -*p*-Toluidino- $\gamma$ -phenylisocrotonitrile. Tinkler. Trans., **103**, 885 (1913).
- m*-Toluenitrile. Baly and Ewbank. Trans., **87**, 1355 (1905).  
 " Purvis. Trans., **107**, 496 (1915).
- o*-Toluenitrile. Baly and Ewbank. Trans., **87**, 1355 (1905).  
 " Purvis. Trans., **107**, 496 (1915).
- p*-Toluenitrile. Baly and Ewbank. Trans., **87**, 1355 (1905).  
 " Purvis. Trans., **107**, 496 (1915).
- Toluquinone. Baly and Stewart. Trans., **89**, 502 (1906).
- m*-Tolyl-2,4-dinitroaniline. Hantzsch. Ber., **43**, 1662 (1910).
- o*-Tolyl-2,4-dinitroaniline. Hantzsch. Ber., **43**, 1651, 1662 (1910).
- p*-Tolyl-2,4-dinitroaniline. Hantzsch. Ber., **43**, 1662 (1910).
- 2-*p*-Tolyl- $\alpha\beta$ -naphthatriazole. Morgan and Micklethwait. Trans., **103**, 71 (1913).
- 3-*p*-Tolyl- $\alpha\beta$ -naphthaisotriazole. Morgan and Micklethwait. Trans., **103**, 71 (1913).
- o*-Tolylpicramide. Hantzsch and Lister. Ber., **43**, 1685 (1910).
- p*-Tolylpicramide. Hantzsch and Lister. Ber., **43**, 1685 (1910).
- Triacetic acid, ethyl ester. Baly, Collie, and Watson. Trans., **95**, 144 (1909).
- Triacetic lactone. Baly, Collie, and Watson. Trans., **95**, 144 (1909).
- Triaminoazobenzene. Hartley. Trans., **51**, 153 (1887).
- p*-Triaminotriphenylmethane, derivatives. Formanek. Zeit. Farb. Text Chem., **2**, 473 (1903).
- Trianhydrotrisdimethylsilicenediol. Robison and Kipping. Trans., **105**, 40 (1914).
- Trianisylcarbinol. Baker. Trans., **91**, 1490 (1907).
- Trianisylmethane. Baker. Trans., **91**, 1490 (1907).
- Tribenzoin. Purvis. Trans., **105**, 1372 (1914).
- Tribenzylamine. Purvis. Trans., **105**, 1372 (1914).
- Tribromobenzene-*anti*-azocyanide. Hantzsch and Lifschitz. Ber., **45**, 3011 (1912).
- Tribromobenzene-*syn*-azocyanide. Hantzsch and Lifschitz. Ber., **45**, 3011 (1912).
- 2,4,6-Tribromophenol. Purvis. Trans., **103**, 1638 (1913).
- Tricarballic acid. Stewart. Trans., **91**, 199 (1907).
- " " Bielecki and Henri. Compt. rend., **157**, 372 (1913); Ber., **46**, 2596 (1913).
- Trichloroacetic acid. Hantzsch. Zeit. phys. Chem., **86**, 624 (1914).  
 " " Wright. Trans., **103**, 528 (1913).  
 " " sodium salt. Wright. Trans., **103**, 528 (1913).
- Trichlorobenzoquinone. Stewart and Baly. Trans., **89**, 618 (1906).
- o*-Trichlorofuchsine. Mayer. Ber., **47**, 1161 (1914).
- 2,4,6-Trichlorophenol. Purvis. Trans., **103**, 1638 (1913).
- 2,3,4-Trichloropicolinamide. Purvis. Trans., **95**, 294 (1909); **103**, 2283 (1913).
- 2,3,4-Trichloropicolinic acid. Purvis. Trans., **95**, 294 (1909).  
 " methyl ester. Purvis. Trans., **95**, 294 (1909).
- 2,3,5-Trichloropyridine. Purvis. Trans., **103**, 2283 (1913).
- 3,4,5-Trichloropyridine. Baker and Baly. Trans., **91**, 1122 (1907).  
 " Purvis. Trans., **103**, 2283 (1913).

- Trichlorotoluquinone. Stewart and Baly. Trans., **89**, 618 (1906).
- 3.5.7-Triethoxy-2-*mp*-diethoxyphenyl-4-ethyl-1.4-benzopyranol anhydrohydriodide. Watson, Sen, and Medhi. Trans., **107**, 1477 (1915).
- 3.5.7-Triethoxy-4-*o*-methoxyphenyl-2-*mp*-diethoxyphenyl-1.4-benzopyranol anhydrohydrochloride. Watson, Sen, and Medhi. Trans., **107**, 1477 (1915).
- Triethylamine. Hartley and Huntington. Phil. Trans., **170**, I. 257 (1879).
- „ Bielecki and Henri. Compt. rend., **156**, 1860 (1913).
- Triethylmelamine. Hartley, Dobbie, and Lauder. Trans., **79**, 848 (1901).
- Triethylisomelamine. Hartley, Dobbie, and Lauder. Trans., **79**, 848 (1901).
- 1.2.3-Trihydroxyanthraquinone. Meek and Watson. Trans., **109**, 544 (1916).
- 1.2.4-Trihydroxyanthraquinone. Meek and Watson. Trans., **109**, 544 (1916).
- 3.5.7-Trihydroxy-2-*mp*-dihydroxyphenyl-4-ethyl-1.4-benzopyranol, anhydride, anhydrohydriodide, and anhydrohydrochloride triethyl ether. Watson, Sen, and Medhi. Trans., **107**, 1477 (1915).
- 3.5.7-Trihydroxy-2-*op*-dihydroxyphenyl-4-methyl-1.4-benzopyranol anhydride. Watson, Sen, and Medhi. Trans., **107**, 1477 (1915).
- 1.2.6-Trihydroxynaphthacenequinone. Baly and Tuck. Trans., **91**, 426 (1907).
- Triketohydrindene diphenyl hydrazone. Purvis. Trans., **99**, 1953 (1911).
- „ hydrate. Purvis. Trans., **99**, 1953 (1911).
- Trimethylamine. Hartley and Huntington. Phil. Trans., **170**, I. 257 (1879).
- „ Bielecki and Henri. Compt. rend., **156**, 1860 (1913).
- Trimethyldihydropyridinedicarboxylic acid, ethyl ester. Baker and Baly. Trans., **91**, 1122 (1907).
- „ „ Ley and v. Engelhardt. Zeit. phys. Chem., **74**, 1 (1910).
- Trimethylethylenc. Stark, Steubing, Enklaar, and Lipp. Jahrb. Radioak., **10**, 139 (1913).
- 2.4.6-Trimethylpyridine. Purvis. Trans., **97**, 692 (1910).
- 2.3.5-Trinitroacetylaminooisole. Meldola and Hewitt. Trans., **103**, 876 (1913).
- 2.3.6-Trinitroacetylaminooisole. Meldola and Hewitt. Trans., **103**, 876 (1913).
- 2.3.5-Trinitro-4-acetylaminophenol. Meldola and Kuntzen. Trans., **97**, 444 (1910).
- 2.3.5-Trinitroaminoanisole. Meldola and Hewitt. Trans., **103**, 876 (1913).
- 2.4.6-Trinitroanisole. Buttle and Hewitt. Trans., **95**, 1755 (1909).
- „ Baly and Rice. Trans., **103**, 2085 (1913).
- 1.3.5-Trinitrobenzene. Hantzsch and Picton. Ber., **42**, 2119 (1909).
- „ Hantzsch. Ber., **43**, 1662 (1910).
- „ Baly and Rice. Trans., **103**, 2085 (1913).
- „ Franchimont and Backer. Proc. K. Akad., Amsterdam, **17**, 647 (1914).
- 2.3.6-Trinitrodimethyl-*p*-toluidine. Morgan and Clayton. Trans., **99**, 1941 (1911).
- Trinitromethane. Hedley. Ber., **41**, 1195 (1908).
- „ Hantzsch and Voigt. Ber., **45**, 85 (1912).
- Trinitrophenylmalonic acid, ethyl ester. Hantzsch and Picton. Ber., **42**, 2119 (1909).
- 2.4.6-Trinitrophenylpiperidine. Morgan, Moss, and Porter. Trans., **107**, 1296 (1915).
- 3.4.5-Trinitro-*o*-xylene. Baly, Tuck, and Marsden. Trans., **97**, 571 (1910).
- 3.4.6-Trinitro-*o*-xylene. Baly, Tuck, and Marsden. Trans., **97**, 571 (1910).
- Triphenyl phosphate. Purvis. Trans., **105**, 1372 (1914).
- Triphenylacetic acid. Purvis. Trans., **105**, 1372 (1914).
- Triphenylamine. Baker. Trans., **91**, 1490 (1907).
- Triphenylcarbinol. Baker. Trans., **91**, 1490 (1907).
- „ Schlenk and Marcus. Ber., **47**, 1664 (1914).
- Triphenylchloromethane. Baker. Trans., **91**, 1490 (1907).
- Triphenylguanidine. Purvis. Trans., **105**, 1372 (1914).
- Triphenylmethane. Hartley. Trans., **51**, 152 (1887).
- „ Baker. Trans., **91**, 1490 (1907).
- Triphenylphosphine. Purvis. Trans., **105**, 1372 (1914).
- Tripropylamine. Bielecki and Henri. Compt. rend., **156**, 1860 (1913).
- Trithiocarbonic acid, ethyl ester. Purvis, Jones, and Tasker. Trans., **97**, 2287 (1910).
- „ „ phenyl ester. Purvis, Jones, and Tasker. Trans., **97**, 2287 (1910).
- Tri-*o*-tolyl phosphate. Purvis. Trans., **105**, 1372 (1914).
- Tri-*p*-tolyl phosphate. Purvis. Trans., **105**, 1372 (1914).

- Tropacolin. Hartley. Trans., **51**, 152 (1887).  
 $\alpha$ -Truxillic acid. Stobbe. Ber., **44**, 960 (1911).  
 Turpentine. Hartley. Trans., **37**, 676 (1880).  
 " Pflüger. Phys. Zeit., **10**, 406 (1909).  
 Tyrosine. Hartley and Huntington. Phil. Trans., **170**, I. 257 (1890).  
 " Soret. Arch. des Sciences, **10**, 429 (1883).

## U

- Urea. Soret. Arch. des Sciences, **10**, 429 (1883).  
 Urethane. Brannigan, Macbeth, and Stewart. Trans., **103**, 406 (1913).  
 Urethanediazohydroxide, salts. Hantzsch and Lifschitz. Ber., **45**, 3011 (1912).  
 " methylether. Hantzsch and Lifschitz. Ber., **45**, 3011 (1912).  
 Uric acid. " Hartley. Trans., **87**, 1796 (1905).  
 " " Soret. Arch. des Sciences, **10**, 429 (1883).  
 " " lithium salt. Hartley. Trans., **87**, 1796 (1905).

## V

- iso*Valeric acid. Wright. Trans., **103**, 528 (1913).  
 " " sodium salt. Wright. Trans., **103**, 528 (1913).  
*n*-Valeric acid. Bielecki and Henri. Compt. rend., **156**, 550 (1913); Ber., **46**, 1304 (1913).  
 Vanadium teracetylacetonate. Morgan and Moss. Trans., **103**, 78 (1913).  
 " terbenzoylacetonate. Morgan and Moss. Trans., **103**, 78 (1913).  
 Vanadyl bisacetylacetonate. Morgan and Moss. Trans., **103**, 78 (1913).  
 " bisbenzoylacetonate. Morgan and Moss. Trans., **103**, 78 (1913).  
 " bismethylacetylacetonate. Morgan and Moss. Trans., **103**, 78 (1913).  
 Vanillin. Purvis. Trans., **105**, 2482 (1914).  
 Veratric acid. Dobbie and Lauder. Trans., **83**, 605 (1903).  
 " " Hartley, Dobbie, and Lauder. Brit. Ass. Report, 1903, 126.  
 Veratrine. Hartley. Phil. Trans., **176**, 471 (1885).  
 Veratrol. Baly and Ewbank. Trans., **87**, 1347 (1905).  
 Violuric acid. Hartley. Trans., **87**, 1796 (1905).  
 " " sodium salt. Hartley. Trans., **87**, 1796 (1905).

## X

- Xanthic acid. Hantzsch and Scharf. Ber., **46**, 3570 (1913).  
 " " anhydride. Hantzsch and Scharf. Ber., **46**, 3570 (1913).  
 " " ethyl ester. Hantzsch and Scharf. Ber., **46**, 3570 (1913).  
 " " potassium salt. Hantzsch and Scharf. Ber., **46**, 3570 (1913).  
 Xanthine. Soret. Arch. des Sciences, **10**, 429 (1883).  
 Xanthochelidonic acid, ethyl ester. Baly, Collic, and Watson. Trans., **95**, 144 (1909).  
*m*-Xylene. Hartley. Trans., **47**, 685 (1885).  
 " Pauer. Ann. der Phys., **61**, 363 (1897).  
 " Baly and Ewbank. Trans., **87**, 1355 (1905).  
 " Grebe. Zeit. wiss. Phot., **3**, 376 (1905).  
 " Hartley. Phil. Trans., **208A**, 475 (1908); Zeit. wiss. Phot., **6**, 299 (1908).  
 " Mies. Zeit. wiss. Phot., **8**, 287 (1910).  
 " Baly and Tryhorn. Trans., **107**, 1058 (1915).  
*o*-Xylene. Hartley. Trans., **47**, 685 (1885).  
 " Pauer. Ann. der Phys., **61**, 363 (1897).  
 " Baly and Ewbank. Trans., **87**, 1355 (1905).  
 " Grebe. Zeit. wiss. Phot., **3**, 376 (1905).  
 " Hartley. Phil. Trans., **208A**, 475 (1908); Zeit. wiss. Phot., **6**, 299 (1908).  
 " Leonard. Trans., **97**, 1246 (1910).  
 " Baly and Tryhorn. Trans., **107**, 1058 (1915).  
*p*-Xylene. Hartley. Trans., **47**, 685 (1885).  
 " Pauer. Ann. der Phys., **61**, 363 (1897).  
 " Baly and Ewbank. Trans., **87**, 1355 (1905).  
 " Grebe. Zeit. wiss. Phot., **3**, 376 (1905).  
 " Hartley. Phil. Trans., **208A**, 475 (1908); Zeit. wiss. Phot., **6**, 299 (1908).  
 " Mies. Zeit. wiss. Phot., **7**, 357 (1909).

- p*-Xylene v. Kowalski. Bull. Akad. Sci., Cracovie, **1A**, 17 (1910).  
 „ Baly and Tryhorn. Trans., **107**, 1058 (1915).  
*m*-2-Xylidine. Purvis. Trans., **97**, 644 (1910).  
*m*-4-Xylidine. Purvis. Trans., **97**, 1546 (1910).  
*m*-Xylidine, acetaldehyde condensation compound. Purvis. Trans., **97**, 644 (1910).  
*o*-3-Xylidine. Purvis. Trans., **97**, 1546 (1910).  
 Xyloquinone. Baly and Stewart. Trans., **89**, 502 (1906).

*List of Organic Compounds the Absorption of which has been examined in the Infra-red.*

**A**

- Acetaldehyde. Weniger. Phys. Rev., **31**, 388 (1910).  
 Acetic acid. Coblenz. Pub. Carnegie Inst., **35** (1905).  
 Acetone. Coblenz. Pub. Carnegie Inst., **35** (1905).  
 Acetonitrile. Coblenz. Pub. Carnegie Inst., **35** (1905).  
 Acetylene. Burmeister. Deutsch. Phys. Ges. Verh., **15**, 589 (1913).  
 „ Coblenz. Pub. Carnegie Inst., **35** (1905).  
 „ Rubens and v. Wartenberg. Deutsch. Phys. Ges. Verh., **13**, 796 (1911).  
 „ Phys. Zeit., **12**, 1080 (1911).  
 Acetylenenol. „ Coblenz. Pub. Carnegie Inst., **35** (1905).  
 Aconitine. Spence. Astrophys. Journ., **39**, 243 (1914).  
 Allyl alcohol. Weniger. Phys. Rev., **31**, 388 (1910).  
 Allyl sulphide. Coblenz. Pub. Carnegie Inst., **35** (1905).  
 Allyl thiocyanate. Coblenz. Pub. Carnegie Inst., **35** (1905).  
*iso*Amyl acetate. Weniger. Phys. Rev., **31**, 388 (1910).  
 Amyl alcohol. Weniger. Phys. Rev., **31**, 388 (1910).  
*iso*Amyl alcohol. Weniger. Phys. Rev., **31**, 388 (1910).  
*tert*-Amyl alcohol. Weniger. Phys. Rev., **31**, 388 (1910).  
*iso*Amyl butyrate. Weniger. Phys. Rev., **31**, 388 (1910).  
*iso*Amyl isobutyrate. Weniger. Phys. Rev., **31**, 388 (1910).  
*iso*Amyl formate. Weniger. Phys. Rev., **31**, 388 (1910).  
*iso*Amyl propionate. Weniger. Phys. Rev., **31**, 388 (1910).  
*iso*Amyl isovalerate. Weniger. Phys. Rev., **31**, 388 (1910).  
 Aniline. Coblenz. Pub. Carnegie Inst., **35** (1905).  
 Anisole. Coblenz. Pub. Carnegie Inst., **35** (1905).  
 Atropine. Spence. Astrophys. Journ., **39**, 243 (1914).

**B**

- Belladonna. Spence. Astrophys. Journ., **39**, 243 (1914).  
 Benzaldehyde. Coblenz. Pub. Carnegie Inst., **35** (1905).  
 Benzene. Coblenz. Pub. Carnegie Inst., **35**, 1905.  
 „ v. Bahr. Ann. der Phys., **33**, 585 (1910).  
 „ Ångström. Ark. Mat. Astron. och Fysik, Stockholm, **8**, No. 26, 1 (1913).  
 Benzoic acid. Spence. Astrophys. Journ., **39**, 243 (1914).  
 Benzotrile. Coblenz. Pub. Carnegie Inst., **35** (1905).  
 Brucine. Spence. Astrophys. Journ., **30**, 243 (1914).  
 Butane. Coblenz. Pub. Carnegie Inst., **35** (1905).  
*iso*Butyl acetate. Weniger. Phys. Rev., **31**, 388 (1910).  
 Butyl alcohol. Weniger. Phys. Rev., **31**, 388 (1910).  
*iso*Butyl alcohol. Weniger. Phys. Rev., **31**, 388 (1910).  
*sec*-Butyl alcohol. Weniger. Phys. Rev., **31**, 388 (1910).  
 Butyl butyrate. Weniger. Phys. Rev., **31**, 388 (1910).  
 Butyric acid. Weniger. Phys. Rev., **31**, 388 (1910).  
*iso*Butyric acid. Weniger. Phys. Rev., **31**, 388 (1910).

- Caproic acid. Coblenz. Pub. Carnegie Inst., **35** (1905).  
*iso*Caproic acid. Coblenz. Pub. Carnegie Inst., **35** (1905).  
 Capryl alcohol. Weniger. Phys. Rev., **31**, 388 (1910).



- Carbon bisulphide. Rubens and v. Wartenberg. *Deutsch. Phys. Ges. Verh.*, **13**, 796 (1911).
- Carbon tetrachloride. Coblenz. *Pub. Carnegie Inst.*, **35** (1905).
- Carvacrol. Coblenz. *Pub. Carnegie Inst.*, **35** (1905).
- Cerotic acid. Coblenz. *Pub. Carnegie Inst.*, **35** (1905).
- Chlorobenzene. Coblenz. *Pub. Carnegie Inst.*, **35** (1905).
- Chloroform. Coblenz. *Pub. Carnegie Inst.*, **35** (1905).
- Chloroheptadecane. Coblenz. *Pub. Carnegie Inst.*, **35** (1905).
- Chlorotridecane. Coblenz. *Pub. Carnegie Inst.*, **35** (1905).
- Cinchonidine. Spence. *Astrophys. Journ.*, **39**, 243 (1914).
- Cocaine. Spence. *Astrophys. Journ.*, **39**, 243 (1914).
- „ hydrochloride. Spence. *Astrophys. Journ.*, **39**, 243 (1914).
- Codeine. Spence. *Astrophys. Journ.*, **39**, 243 (1914).
- Coniine. Spence. *Astrophys. Journ.*, **39**, 243 (1914).
- Cumene. Coblenz. *Pub. Carnegie Inst.*, **35** (1905).
- Cumenol. Coblenz. *Pub. Carnegie Inst.*, **35** (1905).
- Cyanine. Coblenz. *Pub. Carnegie Inst.*, **35** (1905).
- Cyanogen. Rubens and v. Wartenberg. *Deutsch. Phys. Ges. Verh.*, **13**, 796 (1911);  
*Phys. Zeit.*, **12**, 1080 (1911).
- „ Burmeister. *Deutsch. Phys. Ges. Verh.*, **15**, 589 (1913).
- Cymene. Coblenz. *Pub. Carnegie Inst.*, **35** (1905).

**D**

- Decylene. Coblenz. *Pub. Carnegie Inst.*, **35** (1905).
- Diethyl oxalate. Weniger. *Phys. Rev.* **31**, 388 (1910).
- Diethyl succinate. Weniger. *Phys. Rev.*, **31**, 388 (1910).
- Dimethylaniline. Coblenz. *Pub. Carnegie Inst.*, **35** (1905).
- Diphenyl. Coblenz. *Pub. Carnegie Inst.*, **35** (1905).
- Dodecane. Coblenz. *Pub. Carnegie Inst.*, **35** (1905).
- Dodecylene. Coblenz. *Pub. Carnegie Inst.*, **35** (1905).

**E**

- Egonine hydrochloride. Spence. *Astrophys. Journ.*, **39**, 243 (1914).
- Eserine. Spence. *Astrophys. Journ.*, **39**, 243 (1914).
- Ethane. Coblenz. *Pub. Carnegie Inst.*, **35** (1905).
- Ethyl acetate. Weniger. *Phys. Rev.*, **31**, 388 (1910).
- Ethyl alcohol. Coblenz. *Pub. Carnegie Inst.*, **35** (1905).
- „ „ Weniger. *Phys. Rev.*, **31**, 388 (1910).
- „ „ Rubens and v. Wartenberg. *Deutsch. Phys. Ges. Verh.*, **13**, 796 (1911);  
*Phys. Zeit.*, **12**, 1080 (1911).
- „ „ Ångström. *Ark. Mat. Astron. och Fysik, Stockholm*, **8**, No. 26, 1 (1913).
- Ethyl butyrate. Weniger. *Phys. Rev.*, **31**, 388 (1910).
- Ethyl cyanide. Coblenz. *Pub. Carnegie Inst.*, **35** (1905).
- Ethyl ether. Coblenz. *Pub. Carnegie Inst.*, **35** (1905).
- „ „ Rubens and v. Wartenberg. *Deutsch. Phys. Ges. Verh.*, **13**, 796 (1911);  
*Phys. Zeit.*, **12**, 1080 (1911).
- „ „ v. Bahr. *Ann. der Phys.*, **38**, 206 (1912).
- Ethyl hydrosulphide. Coblenz. *Pub. Carnegie Inst.*, **35** (1905).
- Ethyl iodide. Coblenz. *Pub. Carnegie Inst.*, **35** (1905).
- Ethyl malonate. Weniger. *Phys. Rev.*, **31**, 388 (1910).
- Ethyl oxalate. Weniger. *Phys. Rev.*, **31**, 388 (1910).
- Ethyl propionate. Weniger. *Phys. Rev.*, **31**, 388 (1910).
- Ethyl succinate. Coblenz. *Pub. Carnegie Inst.*, **35** (1905).
- „ „ Weniger. *Phys. Rev.*, **31**, 388 (1910).
- Ethyl sulphate. Coblenz. *Pub. Carnegie Inst.*, **35** (1905).
- Ethyl sulphide. Coblenz. *Pub. Carnegie Inst.*, **35** (1905).
- Ethyl thiocyanate. Coblenz. *Pub. Carnegie Inst.*, **35** (1905).
- Ethyl isothiocyanate. Coblenz. *Pub. Carnegie Inst.*, **35** (1905).
- Ethylene. Coblenz. *Pub. Carnegie Inst.*, **35** (1905).
- „ Rubens and v. Wartenberg. *Deutsch. Phys. Ges. Verh.*, **13**, 796 (1911);  
*Phys. Zeit.*, **12**, 1080 (1911).
- Ethylene bromide. Coblenz. *Pub. Carnegie Inst.*, **35** (1905).

- Ethylene glycol. Weniger. *Phys. Rev.*, **31**, 388 (1910).  
 $\beta$ -Eucaine. Spence. *Astrophys. Journ.*, **39**, 243 (1914).  
 Eucalyptol. Coblenz. *Pub. Carnegie Inst.*, **35** (1905).  
 Eugenol. Coblenz. *Pub. Carnegie Inst.*, **35** (1905).

**G**

- Glycerine. Coblenz. *Pub. Carnegie Inst.*, **35** (1905).  
 „ Weniger. *Phys. Rev.*, **31**, 388 (1910).

**H**

- Hexadecane. Coblenz. *Pub. Carnegie Inst.*, **35** (1905).  
 Hexadecylene. Coblenz. *Pub. Carnegie Inst.*, **35** (1905).  
 Hexane. Coblenz. *Pub. Carnegie Inst.*, **35** (1905).  
 Homatropine. Spence. *Astrophys. Journ.*, **39**, 243 (1914).  
 Hydrogen cyanide. Burmeister. *Deutsch. Phys. Ges. Verh.*, **15**, 589 (1913).

**I**

- Iodoform. Coblenz. *Pub. Carnegie Inst.*, **35** (1905).

**L**

- Limonene. Coblenz. *Pub. Carnegie Inst.*, **35** (1905).

**M**

- Menthol. Coblenz. *Pub. Carnegie Inst.*, **35** (1905).  
 Mesitylene. Coblenz. *Pub. Carnegie Inst.*, **35** (1905).  
 Methane. Coblenz. *Pub. Carnegie Inst.*, **35** (1905).  
 „ v. Bahr., *Ann. der Phys.*, **33**, 585 (1910).  
 „ Rubens and v. Wartenberg. *Deutsch. Phys. Ges. Verh.*, **13**, 796 (1911).  
 „ v. Bahr., *Ann. der Phys.*, **38**, 206 (1912).  
 Methyl acetate. Coblenz. *Pub. Carnegie Inst.*, **35** (1905).  
 „ „ Weniger. *Phys. Rev.*, **31**, 388 (1910).  
 „ „ Callow, Lewis, and Nodder. *Trans.*, **109**, 55 (1916).  
 Methyl alcohol. v. Bahr., *Ann. der Phys.*, **33**, 585 (1910).  
 „ „ Weniger. *Phys. Rev.*, **31**, 388 (1910).  
 „ „ Ångström. *Ark. Mat. Astron. och Fysik, Stockholm*, **8**, No. 26, 1 (1913).  
 Methyl butyrate. Weniger. *Phys. Rev.*, **31**, 388 (1910).  
 Methyl isobutyrate. Weniger. *Phys. Rev.*, **31**, 388 (1910).  
 Methyl carbonate. Coblenz. *Pub. Carnegie Inst.*, **35** (1905).  
 Methyl chloride. Rubens and v. Wartenberg. *Deutsch. Phys. Ges. Verh.*, **13**, 796 (1911); *Phys. Zeit.*, **12**, 1080 (1911).  
 Methyl cyanide. *See Acetonitrile.*  
 Methyl ether. Coblenz. *Pub. Carnegie Inst.* **35** (1905).  
 Methyl hexyl carbinol acetic ester. Weniger. *Phys. Rev.*, **31**, 388 (1910).  
 Methyl iodide. Coblenz. *Pub. Carnegie Inst.*, **35** (1905).  
 Methyl propionate. Weniger. *Phys. Rev.*, **31**, 388 (1910).  
 Methyl salicylate. Coblenz. *Pub. Carnegie Inst.*, **35** (1905).  
 Methyl thiocyanate. Coblenz. *Pub. Carnegie Inst.*, **35** (1905).  
 Methyl isothiocyanate. Coblenz. *Pub. Carnegie Inst.*, **35** (1905).  
 Methyl isovalerate. Weniger. *Phys. Rev.*, **31**, 388 (1910).  
 Methylaniline. Coblenz. *Pub. Carnegie Inst.*, **35** (1905).  
 Myricyl alcohol. Coblenz. *Pub. Carnegie Inst.*, **35** (1905).

**N**

- Narcotine. Spence, *Astrophys. Journ.*, **39**, 243 (1914).  
 Nicotine. Spence. *Astrophys. Journ.*, **39**, 243 (1914).  
 Nitrobenzene. Coblenz. *Pub. Carnegie Inst.*, **35** (1905).  
 Nitroethane. Coblenz. *Pub. Carnegie Inst.*, **35** (1905).  
 Nitromethane. Coblenz. *Pub. Carnegie Inst.*, **35** (1905).  
*p*-Nitrosodimethylaniline. Coblenz. *Pub. Carnegie Inst.*, **35** (1905).  
*o*-Nitrotoluene. Coblenz. *Pub. Carnegie Inst.*, **35** (1905).  
*p*-Nitrotoluene. Coblenz. *Pub. Carnegie Inst.*, **35** (1905).

## O

- Octadecane. Coblenz. Pub. Carnegie Inst., 35 (1905).  
 Octadecylene. Coblenz. Pub. Carnegie Inst., 35 (1905).  
 Octane. Coblenz. Pub. Carnegie Inst., 35 (1905).  
 Oleic acid. Coblenz. Pub. Carnegie Inst., 35 (1905).

## P

- Paraldehyde. Coblenz. Pub. Carnegie Inst., 35 (1905).  
 Pentadecylene. Coblenz. Pub. Carnegie Inst., 35 (1905).  
 Pentane. Rubens and v. Wartenberg. Deutsch. Phys. Ges. Verh., 13, 796 (1911)  
 Phys. Zeit., 12, 1080 (1911).  
 Phenol. Coblenz. Pub. Carnegie Inst., 35 (1905).  
 Phenyl acetate. Coblenz. Pub. Carnegie Inst., 35 (1905).  
 Phenyl Mustard Oil. Coblenz. Pub. Carnegie Inst., 35 (1905).  
 Phenyl thiocyanate. Coblenz. Pub. Carnegie Inst., 35 (1905).  
 $\alpha$ -Picoline. Coblenz. Pub. Carnegie Inst., 35 (1905).  
 „ Spence. Astrophys. Journ., 39, 243 (1914).  
 Pilocarpine. Spence. Astrophys. Journ., 39, 243 (1914).  
 Pinene. Coblenz. Pub. Carnegie Inst., 35 (1905).  
 Piperidine. Coblenz. Pub. Carnegie Inst., 35 (1905).  
 „ Spence. Astrophys. Journ., 39, 243 (1914).  
 Piperine. Spence. Astrophys. Journ., 39, 243 (1914).  
 Propionitrile. Coblenz. Pub. Carnegie Inst., No. 35 (1905).  
 Propyl alcohol. Weniger. Phys. Rev., 31, 388 (1910).  
*sec*Propyl alcohol. Weniger. Phys. Rev., 31, 388 (1910).  
 Propylene glycol. Weniger. Phys. Rev., 31, 388 (1910).  
 Pyridine. Coblenz. Pub. Carnegie Inst., 35 (1905).  
 „ Spence. Astrophys. Journ., 39, 243 (1914).  
 Pyrrol. Coblenz. Pub. Carnegie Inst., 35 (1905).

## Q

- Quinidine. Spence. Astrophys. Journ., 39, 243 (1914).  
 Quinoline. Coblenz. Pub. Carnegie Inst., 35 (1905).  
 „ Spence. Astrophys. Journ., 39, 243 (1914).  
 Quinine. Spence. Astrophys. Journ., 39, 243 (1914).  
 „ sulphate. Spence. Astrophys. Journ., 39, 243 (1914).

## R

- Resin. Coblenz. Pub. Carnegie Inst., 35 (1905).

## S

- Safrole. Coblenz. Pub. Carnegie Inst., 35 (1905).  
 Sodium ethoxide. Weniger. Phys. Rev., 31, 388 (1910).  
 Stearic acid. Coblenz. Pub. Carnegie Inst., 35 (1905).

## T

- Terpineol. Coblenz. Pub. Carnegie Inst., 35 (1905).  
 Tetrachloroethylene. Coblenz. Pub. Carnegie Inst., 35 (1905).  
 Tetracosane. Coblenz. Pub. Carnegie Inst., 35 (1905).  
 Tetracosylene. Coblenz. Pub. Carnegie Inst., 35 (1905).  
 Thiophene. Coblenz. Pub. Carnegie Inst., 35 (1905).  
 Thymol. Coblenz. Pub. Carnegie Inst., 35 (1905).  
 Toluene. Coblenz. Pub. Carnegie Inst., 35 (1905).  
 „ Angström. Ark. Mat. Astron. och Fysik, Stockholm, 8, No. 26, 1 (1913).  
 $o$ -Toluidine. Coblenz. Pub. Carnegie Inst., 35 (1905).  
 Triethylamine. Coblenz. Pub. Carnegie Inst., 35 (1905).

## V

- n*-Valeric acid. Coblenz. Pub. Carnegie Inst., 35 (1905).  
 Venice turpentine. Coblenz. Pub. Carnegie Inst., 35 (1905).

## X

- o-Xylene. Coblenz. Pub. Carnegie Inst., **35** (1905).  
 m-Xylene. Coblenz. Pub. Carnegie Inst., **35** (1905).  
 p-Xylene. Coblenz. Pub. Carnegie Inst., **35** (1905).  
 Xylidine. Coblenz. Pub. Carnegie Inst., **35** (1905).

*List of Organic Compounds of which the Fluorescence or Phosphorescence  
 has been Measured.*

## A

- Acetanilide. Ley and v. Engelhardt. Zeit. phys. Chem., **74**, 1 (1910).  
 α-Acetnaphthalide. Fischer. Zeit. wiss. Phot., **6**, 305 (1908).  
 β-Acetnaphthalide. Fischer. Zeit. wiss. Phot., **6**, 305 (1908).  
 Acetone. Stark and Steubing. Phys. Zeit., **9**, 661 (1908).  
 „ Gelbke. Phys. Zeit., **13**, 584 (1912).  
 Acetophenone. Goldstein. Deutsch. Phys. Ges. Verh., **12**, 376 (1910).  
 o-Aminobenzaldehyde. Baly and Krulla. Trans., **101**, 1469 (1912).  
 α-Aminonicotinic acid. Ley and v. Engelhardt. Zeit. Phys. Chem., **74**, 1 (1910).  
 α-Aminopyridine. Ley and v. Engelhardt. Zeit. Phys. Chem., **74**, 1 (1910).  
 Aniline. Stark and Steubing. Phys. Zeit., **9**, 481 (1908).  
 „ Ley and v. Engelhardt. Zeit. phys. Chem., **74**, 1 (1910).  
 „ v. Kowalski. Phys. Zeit., **12**, 956 (1911).  
 „ Dickson. Zeit. wiss. Phot., **10**, 166 (1912).  
 Anilinoacetic acid. Ley and v. Engelhardt. Zeit. phys. Chem., **74**, 1 (1910).  
 o-Anisidine. Ley and v. Engelhardt. Zeit. phys. Chem., **74**, 1 (1910).  
 p-Anisidine. Ley and v. Engelhardt. Zeit. phys. Chem., **74**, 1 (1910).  
 Anisole. Ley and v. Engelhardt. Zeit. phys. Chem., **74**, 1 (1910).  
 „ Baly and Rice. Trans., **101**, 1475 (1912).  
 Anthracene. Elston. Astrophys. Jour., **25**, 155 (1907).  
 „ v. Kowalski. Comptes Rendus, **145**, 1270 (1907).  
 „ Stark and Meyer. Phys. Zeit., **8**, 250 (1907).  
 „ Fischer. Zeit. wiss. Phot., **6**, 305 (1908).  
 „ McDowel. Phys. Rev., **26**, 155 (1908).  
 „ Stark and Steubing. Phys. Zeit., **9**, 481 (1908).  
 „ Stevenson. J. Phys. Chem., **15**, 845 (1911).  
 „ Dickson. Zeit. wiss. Phot., **10**, 166 (1912).  
 Anthranilic acid. Ley and v. Engelhardt. Zeit. phys. Chem., **74**, 1 (1910).  
 Anthranol. Stark and Steubing. Phys. Zeit., **9**, 481 (1908).  
 „ Dickson. Zeit. wiss. Phot., **10**, 166 (1912).  
 Anthraquinone. v. Kowalski. Comptes Rendus, **145**, 1270 (1907).  
 Azodicarbonamide. Stark and Steubing. Phys. Zeit., **9**, 661 (1908).  
 Azodicarboxylic acid, potassium salt. Stark and Steubing. Phys. Zeit., **9**, 661 (1908).

## B

- Benzamide. Ley and v. Engelhardt. Zeit. phys. Chem., **74**, 1 (1910).  
 o-Benzbetain. Ley and v. Engelhardt. Zeit. phys. Chem., **74**, 1 (1910).  
 Benzene. Stark and Meyer. Phys. Zeit., **8**, 250 (1907).  
 „ Stark and Steubing. Phys. Zeit., **9**, 481 (1908).  
 „ Ley and v. Engelhardt. Zeit. phys. Chem., **74**, 1 (1910).  
 „ v. Kowalski. Phys. Zeit., **12**, 956 (1911).  
 „ Dickson. Zeit. wiss. Phot., **10**, 166 (1912).  
 Benzenesulphonic acid. Stark and Steubing. Phys. Zeit., **9**, 481 (1908).  
 Benzil. Stark and Steubing. Phys. Zeit., **9**, 661 (1908).  
 Benzoic acid. Ley and v. Engelhardt. Zeit. phys. Chem., **74**, 1 (1910).  
 „ „ v. Kowalski. Phys. Zeit., **12**, 956 (1911).  
 Benzonitrile. Ley and v. Engelhardt. Zeit. phys. Chem., **74**, 1 (1910).  
 „ v. Kowalski. Phys. Zeit., **12**, 956 (1911).  
 Benzophenone. Stark and Meyer. Phys. Zeit., **8**, 250 (1907).  
 „ Stark and Steubing. Phys. Zeit., **9**, 481 (1908).  
 „ Goldstein. Deutsch. Phys. Ges. Verh., **12**, 376 (1910).

- Benzoyl acetone. Ley and v. Engelhardt. *Zeit. phys. Chem.*, **74**, 1 (1910).  
 Benzyl alcohol. Ley and v. Engelhardt. *Zeit. phys. Chem.*, **74**, 1 (1910).  
 Benzyl chloride. Ley and v. Engelhardt. *Zeit. phys. Chem.*, **74**, 1 (1910).  
 Benzyl cyanide. Ley and v. Engelhardt. *Zeit. phys. Chem.*, **74**, 1 (1910).  
 Benzylamine. Ley and v. Engelhardt. *Zeit. phys. Chem.*, **74**, 1 (1910).  
 „ v. Kowalski. *Phys. Zeit.*, **12**, 956 (1911).  
 Bromobenzene. Stark and Steubing. *Phys. Zeit.*, **9**, 481 (1908).  
 „ Ley and v. Engelhardt. *Zeit. phys. Chem.*, **74**, 1 (1910).

## C

- Camphor. Stark and Steubing. *Phys. Zeit.*, **9**, 661 (1908).  
 Camphorquinone. Stark and Steubing. *Phys. Zeit.*, **9**, 661 (1908).  
 Catechol. Stark and Meyer. *Phys. Zeit.*, **8**, 250 (1907).  
*m*-Chloroaniline. Ley and v. Engelhardt. *Zeit. phys. Chem.*, **74**, 1 (1910).  
*o*-Chloroaniline. Ley and v. Engelhardt. *Zeit. phys. Chem.*, **74**, 1 (1910).  
*p*-Chloroaniline. Ley and v. Engelhardt. *Zeit. phys. Chem.*, **74**, 1 (1910).  
 Chlorobenzene. Stark and Steubing. *Phys. Zeit.*, **9**, 481 (1908).  
 „ Goldstein. *Deutsch. Phys. Ges. Verh.*, **12**, 376 (1910).  
 „ Ley and v. Engelhardt. *Zeit. phys. Chem.*, **74**, 1 (1910).  
*o*-Chlorophenol. Ley and v. Engelhardt. *Zeit. phys. Chem.*, **74**, 1 (1910).  
*o*-Chlorotoluene. Ley and v. Engelhardt. *Zeit. phys. Chem.*, **74**, 1 (1910).  
*p*-Chlorotoluene. Ley and v. Engelhardt. *Zeit. phys. Chem.*, **74**, 1 (1910).  
 Cinnamic acid. Ley and v. Engelhardt. *Zeit. phys. Chem.*, **74**, 1 (1910).  
 Collidinedicarboxylic acid, ethyl ester. Ley and v. Engelhardt. *Zeit. phys. Chem.*, **74**, 1 (1910).  
*m*-Cresol. Ley and v. Engelhardt. *Zeit. phys. Chem.*, **74**, 1 (1910).  
 „ v. Kowalski. *Phys. Zeit.*, **12**, 956 (1911).  
*m*-Cresol methyl ether. v. Kowalski. *Phys. Zeit.*, **12**, 956 (1911).  
*o*-Cresol. Ley and v. Engelhardt. *Zeit. phys. Chem.*, **74**, 1 (1910).  
 „ v. Kowalski. *Phys. Zeit.*, **12**, 956 (1911).  
*o*-Cresol methyl ether. v. Kowalski. *Phys. Zeit.*, **12**, 956 (1911).  
*p*-Cresol. Ley and v. Engelhardt. *Zeit. phys. Chem.*, **74**, 1 (1910).  
 „ v. Kowalski. *Phys. Zeit.*, **12**, 956 (1911).  
*p*-Cresol methyl ether. v. Kowalski. *Phys. Zeit.*, **12**, 956 (1911).  
 $\psi$ -Cumene. v. Kowalski. *Phys. Zeit.*, **12**, 956 (1911).  
 Cymene. v. Kowalski. *Phys. Zeit.*, **12**, 956 (1911).

## D

- Diacetyl. Stark and Steubing. *Phys. Zeit.*, **9**, 661 (1908).  
 „ Gelbke. *Phys. Zeit.*, **12**, 584 (1912).  
 Dibenzyl. Fischer. *Zeit. wiss. Phot.*, **6**, 305 (1908).  
 „ Stark and Steubing. *Phys. Zeit.*, **9**, 481 (1908).  
 Dibromoanthracene. Fischer. *Zeit. wiss. Phot.*, **6**, 305 (1908).  
*p*-Dibromobenzene. Ley and v. Engelhardt. *Zeit. phys. Chem.*, **74**, 1 (1910).  
*p*-Dichlorobenzene. Ley and v. Engelhardt. *Zeit. phys. Chem.*, **74**, 1 (1910).  
 Diethyl ketone. Stark and Steubing. *Phys. Zeit.*, **9**, 661 (1908).  
 Dihydroanthracene. Stevenson. *J. Phys. Chem.*, **15**, 845 (1911).  
 Dihydrocollidinedicarboxylic acid, ethyl ester. Ley and v. Engelhardt. *Zeit. phys. Chem.*, **74**, 1 (1910).  
*p*-Dimethylaminobenzaldehyde. Baly and Krulla. *Trans.*, **101**, 1469 (1912).  
 Dimethyl aniline. Ley and v. Engelhardt. *Zeit. phys. Chem.*, **74**, 1 (1910).  
 Dimethylantranilic acid. Ley and v. Engelhardt. *Zeit. phys. Chem.*, **74**, 1 (1910).  
 Dimethylfulvene. Stark and Steubing. *Phys. Zeit.*, **9**, 661 (1908).  
*o*-Dimethyltoluidine. Ley and v. Engelhardt. *Zeit. phys. Chem.*, **74**, 1 (1910).  
*p*-Dimethyltoluidine. Ley and v. Engelhardt. *Zeit. phys. Chem.*, **74**, 1 (1910).  
 3'6-Dioxyxanthone. Stark and Meyer. *Phys. Zeit.*, **8**, 250 (1907).  
 „ Stark and Steubing. *Phys. Zeit.*, **9**, 481 (1908).  
 Diphenyl. Fischer. *Zeit. wiss. Phot.*, **6**, 305 (1908).  
 „ Stark and Steubing. *Phys. Zeit.*, **9**, 481 (1908).  
 „ Dickson. *Zeit. wiss. Phys.*, **10**, 166 (1912).  
 Diphenyl ketone. Stark and Steubing. *Phys. Zeit.*, **9**, 661 (1908).  
 Diphenylamine. Stark and Steubing. *Phys. Zeit.*, **9**, 481 (1908).  
 „ Dickson. *Zeit. wiss. Phot.*, **10**, 181 (1912).

- Diphenylmethane. Stark and Steubing. *Phys. Zeit.*, **9**, 481 (1908).  
 „                    Dickson. *Zeit. wiss. Phot.*, **10**, 166 (1912).  
 Durene. Stark and Steubing. *Phys. Zeit.*, **9**, 481 (1908).

**E**

- Eosin. Nichols and Merritt. *Phys. Rev.*, **31**, 381 (1910).  
 Ethyl benzoate. Ley and v. Engelhardt. *Zeit. phys. Chem.*, **74**, 1 (1910).  
 Ethylaniline. Ley and v. Engelhardt. *Zeit. phys. Chem.*, **74**, 1 (1910).  
 Ethylbenzene. Ley and v. Engelhardt. *Zeit. phys. Chem.*, **74**, 1 (1910).  
 „                    v. Kowalski. *Phys. Zeit.*, **12**, 956 (1911).  
 Ethylenecyanidemonooxalic acid, ethyl ester. Gelbke. *Phys. Zeit.*, **13**, 584 (1912).

**F**

- Fluorane. Stark and Meyer. *Phys. Zeit.*, **8**, 250 (1907).  
 „                    Stark and Steubing. *Phys. Zeit.*, **9**, 481 (1908).  
 Fluorescein. Stark and Meyer. *Phys. Zeit.*, **8**, 250 (1907).  
 „                    Kaempfer. *Phys. Zeit.*, **12**, 761 (1911).  
 „                    Mecklenberg and Valentiner. *Phys. Zeit.*, **15**, 267 (1914).  
 Fluorobenzene. Ley and v. Engelhardt. *Zeit. phys. Chem.*, **74**, 1 (1910).

**H**

- Hexamethylbenzene. Ley and v. Engelhardt. *Zeit. phys. Chem.*, **74**, 1 (1910).  
 Hydrocinnamic acid. *See*  $\beta$ -Phenylpropionic acid.  
 Hydroquinone. *See* Quinol.

**I**

- Iodobenzene. Stark and Steubing. *Phys. Zeit.*, **9**, 481 (1908).  
 „                    Ley and v. Engelhardt. *Zeit. phys. Chem.*, **74**, 1 (1910).

**M**

- Mandelic acid. Ley and v. Engelhardt. *Zeit. phys. Chem.*, **74**, 1 (1910).  
 Mercurydiphenyl. Ley and v. Engelhardt. *Zeit. phys. Chem.*, **74**, 1 (1910).  
 Mesitylene. Stark and Steubing. *Phys. Zeit.*, **9**, 481 (1908).  
 „                    v. Kowalski. *Phys. Zeit.*, **12**, 976 (1911).  
 „                    Dickson. *Zeit. wiss. Phot.*, **10**, 166 (1912).  
 Mesitylenic acid. Goldstein. *Deutsch. Phys. Ges. Verh.*, **12**, 376 (1910).  
 Methyl ethyl ketone. Stark and Steubing. *Phys. Zeit.*, **9**, 661 (1908).  
 Methylanthracene. Stark and Steubing. *Phys. Zeit.*, **9**, 481 (1908).  
 Methylanthranilic acid. Ley and v. Engelhardt. *Zeit. phys. Chem.*, **74**, 1 (1910).  
*o*-Methoxybenzoic acid. Ley and v. Engelhardt. *Zeit. phys. Chem.*, **74**, 1 (1910).  
*p*-Methoxybenzoic acid. Ley and v. Engelhardt. *Zeit. phys. Chem.*, **74**, 1 (1910).

**N**

- Naphthalene. Stark and Meyer. *Phys. Zeit.*, **8**, 250 (1907).  
 „                    Fischer. *Zeit. wiss. Phot.*, **6**, 305 (1908).  
 „                    Stark and Steubing. *Phys. Zeit.*, **9**, 481 (1908).  
 „                    Ley and v. Engelhardt. *Zeit. phys. Chem.*, **74**, 1 (1910).  
 „                    Dickson. *Zeit. wiss. Phot.*, **10**, 166 (1912).  
 $\alpha$ -Naphthol. Fischer. *Zeit. wiss. Phot.*, **6**, 305 (1908).  
 „                    Stark and Steubing. *Phys. Zeit.*, **9**, 481 (1908).  
 „                    Dickson. *Zeit. wiss. Phot.*, **10**, 181 (1912).  
 $\beta$ -Naphthol. Fischer. *Zeit. wiss. Phot.*, **6**, 305 (1908).  
 „                    Stark and Steubing. *Phys. Zeit.*, **9**, 481 (1908).  
 „                    Dickson. *Zeit. wiss. Phot.*, **10**, 181 (1912).  
 Naphthonitrile. Fischer. *Zeit. wiss. Phot.*, **6**, 305 (1908).  
 $\alpha$ -Naphthylamine. Fischer. *Zeit. wiss. Phot.*, **6**, 305 (1908).  
 „                    Stark and Steubing. *Phys. Zeit.*, **9**, 481 (1908).  
 „                    Dickson. *Zeit. wiss. Phot.*, **10**, 181 (1912).  
 $\beta$ -Naphthylamine. Fischer. *Zeit. wiss. Phot.*, **6**, 305 (1908).  
 „                    Stark and Steubing. *Phys. Zeit.*, **9**, 481 (1908).  
 „                    Dickson. *Zeit. wiss. Phot.*, **10**, 181 (1912).

- Nitroaniline. Dzierzlicki and v. Kowalski. *Bull. Akad. Sci., Cracovie*, **5**, 724 (1909).  
*o*-Nitroaniline. Ley and v. Engelhardt. *Zeit. phys. Chem.*, **74**, 1 (1910).  
 Nitrobenzene. Ley and v. Engelhardt. *Zeit. phys. Chem.*, **74**, 1 (1910).  
*o*-Nitrophenol. Ley and v. Engelhardt. *Zeit. phys. Chem.*, **74**, 1 (1910).  
*p*-Nitrophenol. Ley and v. Engelhardt. *Zeit. phys. Chem.*, **74**, 1 (1910).

## O

- Oxalosuccinonitrile. Gelbke. *Phys. Zeit.*, **12**, 584 (1911).  
*m*-Oxybenzoic acid. Ley and v. Engelhardt. *Zeit. phys. Chem.*, **74**, 1 (1910).  
 " " v. Kowalski. *Phys. Zeit.*, **12**, 956 (1911).  
*o*-Oxybenzoic acid. Ley and v. Engelhardt. *Zeit. phys. Chem.*, **74**, 1 (1910).  
 " " v. Kowalski. *Phys. Zeit.*, **12**, 956 (1911).  
*p*-Oxybenzoic acid. Ley and v. Engelhardt. *Zeit. phys. Chem.*, **74**, 1 (1910).  
 " " v. Kowalski. *Phys. Zeit.*, **12**, 956 (1911).  
 Oxyhydroquinone. Stark and Steubing. *Phys. Zeit.*, **9**, 481 (1908).

## P

- Phenanthrene. Elston. *Astrophys. Journ.*, **25**, 155 (1907).  
 " v. Kowalski. *Comptes rendus*, **145**, 1270 (1907).  
 " Stark and Meyer. *Phys. Zeit.*, **8**, 250 (1907).  
 " Fischer. *Zeit. wiss. Phot.*, **6**, 305 (1908).  
 " Stark and Steubing. *Phys. Zeit.*, **9**, 481 (1908).  
 " Dickson. *Zeit. wiss. Phot.*, **10**, 166 (1912).  
 Phenol. Stark and Steubing. *Phys. Zeit.*, **9**, 481 (1908).  
 " Ley and v. Engelhardt. *Zeit. Phys. Chem.*, **74**, 1 (1910).  
 " v. Kowalski. *Phys. Zeit.*, **12**, 956 (1911).  
 " Dickson. *Zeit. wiss. Phot.*, **10**, 181 (1912).  
 Phenolphthalein. Stark and Meyer. *Phys. Zeit.*, **8**, 250 (1907).  
 " Stark and Steubing. *Phys. Zeit.*, **9**, 481 (1908).  
 Phenoxylacetic acid. Ley and v. Engelhardt. *Zeit. phys. Chem.*, **74**, 1 (1910).  
 Phenylacetic acid. Ley and v. Engelhardt. *Zeit. phys. Chem.*, **74**, 1 (1910).  
 " " v. Kowalski. *Phys. Zeit.*, **12**, 956 (1911).  
 Phenylacetylene. Ley and v. Engelhardt. *Zeit. phys. Chem.*, **74**, 1 (1910).  
 Phenylamidoacetic acid. Ley and v. Engelhardt. *Zeit. phys. Chem.*, **74**, 1 (1910).  
 Phenylpropionic acid. Ley and v. Engelhardt. *Zeit. phys. Chem.*, **74**, 1 (1910).  
 $\beta$ -Phenylpropionic acid. Ley and v. Engelhardt. *Zeit. phys. Chem.*, **74**, 1 (1910).  
 Phenyltrimethylammonium chloride. Ley and v. Engelhardt. *Zeit. phys. Chem.*, **74**, 1 (1910).  
 Phenyltrimethylammonium iodide. Ley and v. Engelhardt. *Zeit. phys. Chem.*, **74**, 1 (1910).  
 Phloroglucinol. Stark and Steubing. *Phys. Zeit.*, **9**, 481 (1908).  
 Phorone. Stark and Steubing. *Phys. Zeit.*, **9**, 661 (1908).  
 Phthalamide. Ley and v. Engelhardt. *Zeit. phys. Chem.*, **74**, 1 (1910).  
 Phthalic acid. Stark and Meyer. *Phys. Zeit.*, **8**, 250 (1907).  
 " " Stark and Steubing. *Phys. Zeit.*, **9**, 481 (1908).  
 " " Ley and v. Engelhardt. *Zeit. phys. Chem.*, **74**, 1 (1910).  
 Phthalic aldehyde. Goldstein. *Deutsch. Phys. Ges. Verh.*, **12**, 376 (1910).  
 Phthalic anhydride. Ley and v. Engelhardt. *Zeit. phys. Chem.*, **74**, 1 (1910).  
 Phthalide. Ley and v. Engelhardt. *Zeit. phys. Chem.*, **74**, 1 (1910).  
 Propylbenzene. Ley and v. Engelhardt. *Zeit. phys. Chem.*, **74**, 1 (1910).  
 " v. Kowalski. *Phys. Zeit.*, **12**, 956 (1911).  
 Pyridine. Ley and v. Engelhardt. *Zeit. phys. Chem.*, **74**, 1 (1910).  
 Pyrocatechol. Stark and Steubing. *Phys. Zeit.*, **9**, 481 (1908).  
 Pyrogallol. Stark and Steubing. *Phys. Zeit.*, **9**, 481 (1908).  
 Pyruvic acid. Stark and Steubing. *Phys. Zeit.*, **9**, 661 (1908).

## Q

- Quinine sulphate. Stark and Steubing. *Phys. Zeit.*, **9**, 481 (1908).  
 " " Dickson. *Zeit. wiss. Phot.*, **10**, 181 (1912).  
 Quinol. Stark and Steubing. *Phys. Zeit.*, **9**, 481 (1908).  
 " Dickson. *Zeit. wiss. Phot.*, **10**, 181 (1912).  
 Quinol dimethylether. Baly and Rice. *Trans.*, **101**, 1475 (1912).

- Quinoline. Stark and Steubing. *Phys. Zeit.*, **9**, 481 (1908).  
 „ Ley and v. Engelhardt. *Zeit. phys. Chem.*, **74**, 1 (1910).  
 „ Dickson. *Zeit. wiss. Phot.*, **10**, 181 (1912).  
*iso*Quinoline. Ley and v. Engelhardt. *Zeit. phys. Chem.*, **74**, 1 (1910).  
 Quinone. Stark and Meyer. *Phys. Zeit.*, **8**, 250 (1907).  
 Quinonephthalein. Stark and Meyer. *Phys. Zeit.*, **8**, 250 (1907).  
 „ Stark and Steubing. *Phys. Zeit.*, **9**, 481 (1908).

**R**

- Resorcin. Stark and Meyer. *Phys. Zeit.*, **8**, 250 (1907).  
 „ Stark and Steubing. *Phys. Zeit.*, **9**, 481 (1908).  
 Resorcinol dimethylether. Baly and Rice. *Trans.*, **101**, 1475 (1912).  
 Resorufin. Wick. *Phys. Zeit.*, **8**, 681 (1907); **8**, 692 (1907).  
 „ Nichols and Merritt. *Phys. Rev.* **31**, 381 (1910).

**S**

- Styrol. Ley and v. Engelhardt. *Zeit. phys. Chem.*, **74**, 1 (1910).

**T**

- Tetrahydroquinoline. Ley and v. Engelhardt. *Zeit. phys. Chem.*, **74**, 1 (1910).  
*pp*-Tetramethyldiaminobenzophenone. Baly and Krulla. *Trans.*, **101**, 1469 (1912).  
 Tetramethyldiaminoxanthone. Stark and Meyer. *Phys. Zeit.*, **8**, 250 (1907).  
 „ Stark and Steubing. *Phys. Zeit.*, **9**, 481 (1908).  
 Toluene. Stark and Steubing. *Phys. Zeit.*, **9**, 481 (1908).  
 „ Ley and v. Engelhardt. *Zeit. phys. Chem.*, **74**, 1 (1910).  
 „ v. Kowalski. *Phys. Zeit.*, **12**, 956 (1911).  
 „ Dickson. *Zeit. wiss. Phot.*, **10**, 166 (1912).  
*m*-Toluic acid. Goldstein. *Deutsch. Phys. Ges. Verh.*, **12**, 376 (1910).  
 „ v. Kowalski. *Phys. Zeit.*, **12**, 956 (1911).  
*o*-Toluic acid. v. Kowalski. *Phys. Zeit.*, **12**, 956 (1911).  
*p*-Toluic acid. v. Kowalski. *Phys. Zeit.*, **12**, 956 (1911).  
*m*-Toluidine. Ley and v. Engelhardt. *Zeit. phys. Chem.*, **74**, 1 (1910).  
*o*-Toluidine. Ley and v. Engelhardt. *Zeit. phys. Chem.*, **74**, 1 (1910).  
*p*-Toluidine. Ley and v. Engelhardt. *Zeit. phys. Chem.*, **74**, 1 (1910).  
*o*-Tolunitrile. Ley and v. Engelhardt. *Zeit. phys. Chem.*, **74**, 1 (1910).  
*p*-Tolunitrile. Ley and v. Engelhardt. *Zeit. phys. Chem.*, **74**, 1 (1910).  
*m*-Toluonitrile. v. Kowalski. *Phys. Zeit.*, **12**, 956 (1911).  
*o*-Toluonitrile. v. Kowalski. *Phys. Zeit.*, **12**, 956 (1911).  
*p*-Toluonitrile. v. Kowalski. *Phys. Zeit.*, **12**, 956 (1911).  
 Triphenylamine. Stark and Steubing. *Phys. Zeit.*, **9**, 481 (1908).  
 Triphenylcarbinol. Baly and Krulla. *Trans.*, **101**, 1469 (1912).  
 Triphenylmethane. Stark and Steubing. *Phys. Zeit.*, **9**, 481 (1908).  
 „ Dickson. *Zeit. wiss. Phot.*, **10**, 166 (1912).

**X**

- Xanthone. Stark and Meyer. *Phys. Zeit.*, **8**, 250 (1907).  
 „ Fischer. *Zeit. wiss. Phot.*, **6**, 305 (1908).  
 „ Stark and Steubing. *Phys. Zeit.*, **9**, 481 (1908).  
*m*-Xylene. Stark and Steubing. *Phys. Zeit.*, **9**, 481 (1908).  
 „ v. Kowalski. *Phys. Zeit.*, **12**, 956 (1911).  
 „ Dickson. *Zeit. wiss. Phot.*, **10**, 166 (1912).  
*o*-Xylene. Fischer. *Zeit. wiss. Phot.*, **6**, 305 (1908).  
 „ Stark and Steubing. *Phys. Zeit.*, **9**, 481 (1908).  
 „ v. Kowalski. *Phys. Zeit.*, **12**, 956 (1911).  
 „ Dickson. *Zeit. wiss. Phot.*, **10**, 166 (1912).  
*p*-Xylene. Fischer. *Zeit. wiss. Phot.*, **6**, 305 (1908).  
 „ Stark and Steubing. *Phys. Zeit.*, **9**, 481 (1908).  
 „ v. Kowalski. *Phys. Zeit.*, **12**, 956 (1911).  
 „ Dickson. *Zeit. wiss. Phot.*, **10**, 166 (1912).  
 1,4,5-Xylenol. v. Kowalski. *Phys. Zeit.*, **12**, 956 (1911).



*Fuel Economy.*—*First Report of the Committee, consisting of* Professor W. A. BONE\* (*Chairman*), Mr. E. D. SIMON\* (*Secretary*), the Rt. Hon. LORD ALLERTON,\* Mr. ROBERT ARMITAGE, Professor J. O. ARNOLD, Mr. J. A. F. ASPINALL, Mr. A. H. BARKER, Professor P. P. BEDSON, Sir G. T. BEILBY,\* Sir HUGH BELL,\* Mr. E. BURY, Dr. CHARLES CARPENTER,\* Dr. DUGALD CLERK,\* Professor H. B. DIXON, Dr. J. T. DUNN,\* Mr. S. Z. DE FERRANTI, Dr. WILLIAM GALLOWAY, Professor W. W. HALDANE GEE, Professor THOS. GRAY, Mr. T. Y. GREENER,\* Sir ROBERT HADFIELD,\* Dr. H. S. HELE-SHAW,\* Mr. D. H. HELPS, Mr. GREVILLE JONES, Mr. W. W. LACKIE, Mr. MICHAEL LONGRIDGE, Dr. J. W. MELLOR, Mr. C. H. MERZ,\* Mr. ROBERT MOND,\* Mr. BERNARD MOORE, Hon. Sir CHARLES PARSONS,\* Sir RICHARD REDMAYNE,\* Professor RIPPER, Professor L. T. O'SHEA, Mr. R. P. SLOAN, Dr. J. E. STEAD,\* Dr. A. STRAHAN,\* Mr. C. E. STROMEYER, Mr. BENJAMIN TALBOT, Professor R. THRELFALL, Mr. G. BLAKE WALKER, Dr. R. V. WHEELER, Mr. B. W. WINDER, Mr. W. B. WOODHOUSE, Professor W. P. WYNNE, and Mr. H. JAMES YATES,\* *appointed for the investigation of Fuel Economy, the Utilisation of Coal, and Smoke Prevention.*

### *Introduction.*

THE national aspects of fuel economy may be considered from two somewhat different standpoints, namely, (1) in view of the economic situation created by the war, which will necessitate the general adoption of more scientific methods in the future development and utilisation of the nation's mineral reserves, and (2) in view of that remoter, but possibly not far distant, future when our available coal supplies will be restricted by approaching exhaustion. In approaching its task the Committee decided that it could best serve the national interest by concentrating its attention upon the more immediate aspect of the problem.

It can hardly be questioned that the chief material basis of the great industrial and commercial expansion of this country during the past century has been its abundant supplies of easily obtainable coal, which, until recent years, has given us a position of advantage over all other countries. It is also equally true that we can no longer claim any advantage in this respect over our two closest competitors.

There can be little doubt but that up to the present we have been wasteful and improvident in regard to our methods of getting and utilising coal, and that not only are great economies in both these

directions attainable, but also that the question of the general adoption of more scientific methods in regard to these matters is one of vital importance, in view of the trying period of economic recuperation which will immediately succeed the war.

For some years before the war the average price of coal at the pit-head had been decidedly on the up-grade, owing chiefly to deeper workings, higher wages, and greater precautions for ensuring the safety of the mines. The result of the great coal strike of 1912, and the legislation which it provoked, was to accentuate this tendency. And if, as seems probable, prices continue to rise for some time after the war at an accelerated rate, as compared with the pre-war period, the question of the best utilisation of fuels will be of increasing importance to the nation.

If anything ought to arouse public opinion to the gravity of the situation, it is surely afforded by the statistics published in the Report upon the World's Coal Resources, issued by the International Geological Congress in the year 1913. According to this estimate, the geographical distribution of the world's total possible and probable reserves of coal of all kinds available within 6,000 feet of the surface (amounting in all to 7,397,553 million metric tons) may be represented diagrammatically as follows:

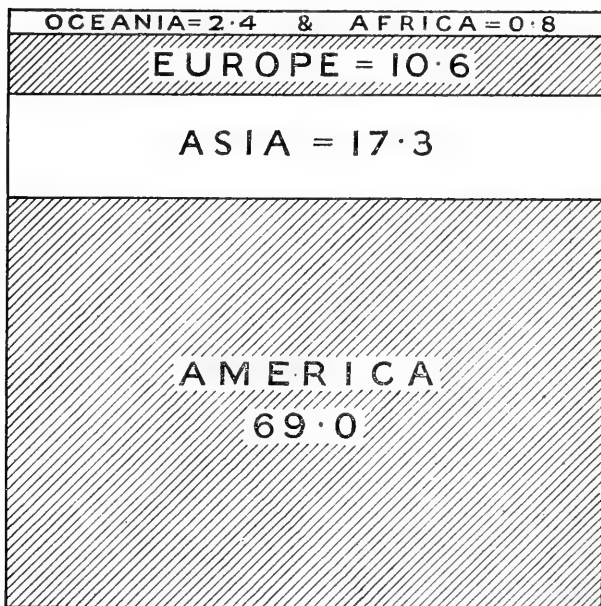

PERCENTAGES OF WORLD'S TOTAL COAL RESERVES.

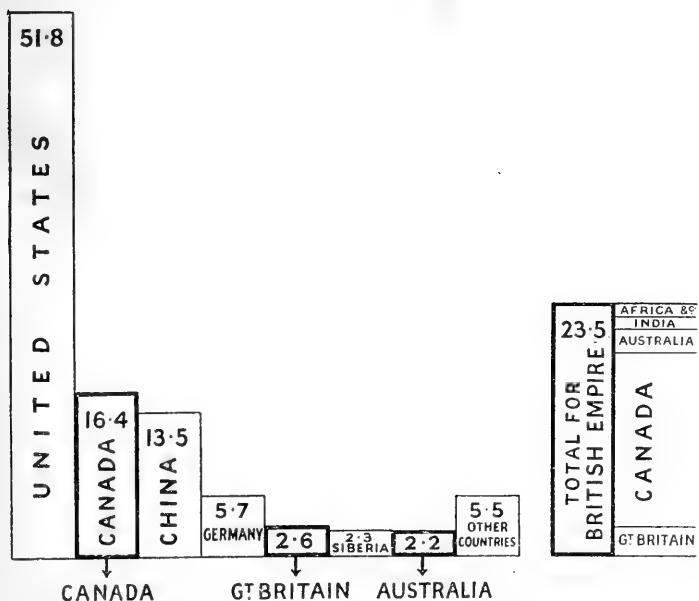

PERCENTAGES OF WORLD'S TOTAL COAL RESERVES.

The fact that the available reserves of coal in Great Britain only amount to about one-fortieth, whilst those of the whole Empire do not amount to more than about one-fourth, of the world's estimated total, is one which ought to be brought home to everyone responsible for the economic development of our national and imperial resources, especially in view of the fact that the United States, whose competition in the immediate future will probably be much more severely felt than ever before, possesses more than half the estimated world's coal, and that also in regard to the two prime considerations of quality and cost of production she probably compares favourably with Great Britain and the Empire.

Moreover, it may be pointed out that in the United States both the Government and the University of Illinois have, for some years past, conducted numerous important chemical investigations and large-scale trials upon the character of the principal American coal seams and their adaptation for various economic ends, and that, in consequence, American manufacturers have at their disposal much more complete and systematic information about their country's coal resources than is at present possessed by their British competitors. Also, the United States Government, which is continually extending its policy of the conservation of its natural resources, has already taken legislative steps to prevent the premature exploitation of the coalfields of Alaska.

Nor has Canada lagged behind her neighbour, as is proved by the recent exhaustive 'Investigation of the Coals of Canada with reference to their Economic Qualities,' conducted at the McGill University, Montreal, under the authority of the Dominion Government, and published in the years 1912 and 1913 by the Department of Mines in six imposing volumes. No such comprehensive investigations have ever been undertaken in this country, where they are much needed. The Committee is of opinion that the example of the United States and Canada might be followed with advantage to the industrial community by the Government of Great Britain, and that representations should be made with the object of inducing the Government to provide adequate funds in aid of further researches and investigations upon the chemical character of the principal British coal seams, the best means for their future development in the national interest, and upon problems of fuel economy, including the utilisation of all the by-products obtainable from coal.

The rapid increase during recent years in the world's demands for coal is shown by the following approximate figures covering the ten years' period immediately preceding the outbreak of war:—

Year	Approximate total Millions of Tons
1903 . . . . .	800
1908 . . . . .	1,000
1913 . . . . .	1,250

From these figures it would appear that, during the period in question, the world's demands have continuously increased at a compound interest rate of nearly 5 per cent. per annum. Another important fact is that these demands have been principally met by three countries, namely, the United States, Great Britain, and Germany, which, between them, have hitherto annually raised 83 per cent. of the total anthracite and bituminous coals consumed in the world. This being so, it is of interest to compare the relative rates of increase in the coal productions of these three countries during recent years, which may best be deduced from a comparison of quinquennial averages over a period of fifteen years, from 1900-1914 inclusive, as follows:—

*Coal Productions of the United States, Great Britain, and Germany—  
Quinquennial Averages 1900 to 1914.*

Period	Millions of Tons per annum		
	United States	Great Britain	Germany <sup>1</sup>
1900-04 . . . . .	288·2	226·8	112·5
1905-09 . . . . .	400·5	256·0	139·8
1910-14 . . . . .	519·2	269·9	168·3

<sup>1</sup> Excluding Lignites and Brown Coals.

From these figures it may be inferred that up to the outbreak of the war the coal output of the United States was increasing annually at a compound interest rate of about 6 per cent., that of Germany at a compound rate of about 4 per cent., whilst the British output was increasing at a compound rate of 2 per cent. only. During the period 1910-14 the United States produced nearly twice as much coal as Great Britain, and, assuming that these relative rates of increase are maintained after the war, it may be predicted that Germany's output of coal will overtake that of Great Britain about twenty years hence, when each country will be producing some 420,000,000 tons per annum.

The public cannot be too often reminded that not only is coal of prime importance as a fuel, but also that, when suitably handled by the chemist, it yields very valuable by-products, which are the raw materials of important industries. Thus from coal-tar, and other by-products of its distillation, are obtained the raw materials for the manufacture of both synthetic dyes and drugs and certain high explosives. Another important by-product obtainable is ammonia in the form of sulphate, which is chiefly used as a fertiliser in the production of foodstuffs. The use of artificial fertilisers, including ammonium sulphate, by agriculturists in Great Britain is still in its infancy, and the near future ought to see a large expansion in the home demands for nitrogenous fertilisers.

Among other products obtainable by the low-temperature distillation of coal are liquid hydrocarbons of the paraffin and naphthene series, and it is probable that large quantities of 'motor spirit' could be manufactured in this country from coal. There is no doubt that we in this country have not been sufficiently alive to the importance of recovering such by-products from the raw coal raised in our mines, and that we have been very much behind Germany in this respect. Thus, for example, whilst in the coking industry modern by-product recovery plants had been universally installed years ago throughout Germany, we were, in 1913, still carbonising about six and a half million tons of coal annually for metallurgical coke in old-fashioned bee-hive ovens. Also, whereas our total production of ammonium sulphate from coal was in 1913 about 318,000 tons, Germany produced nearly half a million tons from a very much smaller output of coal.

The community needs to be reminded that, at least so far as this country is concerned, progress in fuel economy involves something more than increased thermal efficiency in respect of power production and of heating operations generally, important as these undoubtedly are. It also involves the whole question of the better utilisation of our coal, including the recovery of by-products and the consequent abolition of the smoke nuisance, which at present, directly and indirectly, costs the country many millions of pounds per annum.

There are two outstanding features in the history of the British coal trade to which the Committee desires to draw attention. One is the remarkably steady increase in the total output of our mines, which, since 1870, has been maintained at an almost uniform compound interest rate of 2 per cent. per annum, as the following table of quinquennial averages over a period of forty-five years—1870-1914—shows:

*British Outputs of Coal 1870-1914.*  
*Coal Production in Great Britain—Quinquennial Averages,*  
*1870 to 1914—Millions of Tons per Annum.*

Period	Average Output	Calculated at 2 per cent. Compound Interest	Proportion of Total Output Exported
1870-74 . . .	121·5	121·5	0·13
1875-79 . . .	133·6	131·1	0·146
1880-84 . . .	156·4	148·1	0·172
1885-89 . . .	165·2	163·5	0·200
1890-94 . . .	180·3	180·5	0·220
1895-99 . . .	202·0	199·3	0·237
1900-04 . . .	226·8	220·1	0·27
1905-09 . . .	256·0	243·0	0·31
1910-14 . . .	269·9	268·2	0·326

The second feature is the phenomenal growth of our export trade, which, during the past sixty years, has increased something like twenty-fold, both as regards the quantities and the values of coal exported. Moreover, its value relative to other values exported has, during the same period, increased fourfold, until at the outbreak of war it constituted about 10 per cent. of our total exported values. We were then actually transacting over 70 per cent. of the total sea-borne coal trade of the world. It must, however, be borne in mind that a considerable proportion of the exported coal supplies the needs of our mercantile marine.

Another circumstance which demands attention is the fact that the proportion of the coal raised annually in the United Kingdom which is exported has been doubled within the past thirty-five years, trebled within half a century, and is still increasing. Three factors have operated in producing this result. One is the proximity of the finest coalfields to our ports, another is the increased demands for coal from Europe and South America, while a third has been the phenomenal growth of our mercantile marine.

The foregoing figures for the total outputs of our mines by no means represent the real rate of depletion of our available coal reserves. A vast amount of usable coal is left behind in the mine because, under present individualistic conditions, it does not pay to bring it to the surface. A larger profit on the capital of a colliery company can often be earned by working the better classes of coal and leaving the less valuable grades underground. According to figures issued in the Report of the 1905 Royal Commission on Coal Supplies, this wastage amounted to nearly 25 per cent. of the total raised in the larger coalfields. The question of checking this wastage by finding out in what ways the less valuable grades can be turned to good account commercially is one of supreme national importance, and the Committee desires to draw special attention to it. Much of the coal now left behind in the mines ought to be converted into useful forms of energy and products for public purposes, and one of the most important aspects of the fuel-economy problem in Great Britain is the devising and

organising of means for making it possible to raise this hitherto wasted coal at an economic advantage.

So much for the general statistics of coal production. Coming now to the possible saving in the coal consumed annually in this country at the outbreak of the war (nearly 200,000,000 tons), it will be remembered that the 1905 Royal Commission on Coal Supplies found that the possible saving in our then annual coal consumption (167,000,000 tons) amounted to between forty and sixty million tons. There are many competent judges who consider that, notwithstanding the improved apparatus which has been put into use in the best factories throughout the country during the last ten years, the average result obtained for the country as a whole still lags behind the best obtainable to-day in as great a proportion as it did in 1905. It will be the business of this Committee (1) to estimate as nearly as may be the present possible margin of saving, and (2) to point out the particular directions in which it can be attained from a national point of view.

#### *Organisation of the Committee's Work.*

Having regard to the magnitude of its work, and the fact that the coal question is one upon which almost every branch of manufacturing and transport industry is dependent, the original Committee of thirteen members appointed by the Association in October 1915 decided to exercise somewhat freely its powers of co-option, so as to make a General Committee sufficiently large and representative of all the important interests involved.

For the more detailed and special study of particular aspects of the fuel question the enlarged General Committee resolved itself into the following five Sub-Committees, each of which subsequently elected its own Chairman and, subject to its reporting from time to time to the General Committee, proceeded to make such arrangements as seemed best for the prosecution of its work:—

- (A) Chemical and Statistical.
- (B) Carbonisation.
- (C) Metallurgical, Ceramic, and Refractory Materials.
- (D) Power and Steam Raising.
- (E) Domestic Heating and Smoke Prevention.

The General Committee next appointed an Executive Committee, composed of the Chairman and Secretary of the General Committee, the Chairman of each Sub-Committee (*ex officio*), and twelve other members, which could meet frequently in London for the discussion of matters relative to the organisation and co-ordination of the work of the Committee as a whole, to deal with matters arising out of the proceedings of the Sub-Committees which might require immediate action or decision, and to receive and consider communications either from Government Departments or Technical Associations concerning subjects under investigation by the Committee.

The General Committee has met in London four times since its appointment in October 1915, the various Sub-Committees have each met about four times since their formation in January 1916, whilst the Executive Committee has met regularly on alternate Fridays since April 28 last. In all, thirty meetings have been held during the year.

At the first meeting of the General Committee it was decided to organise a series of conferences of manufacturers and others interested in the fuel question in a number of the larger industrial centres, for the purposes of arousing interest in the work of the Committee, of inviting co-operation and suggestions from large users of fuel, and of educating public opinion in respect of the national importance of the question.

The following six conferences have already been held:—

Date	Place	Under the Auspices of
1915. November 19 .	Stoke-on-Trent	{ English Ceramic Society, North Staffs Mining Institute.
1916. March 6 . . .	London . . .	London Section of the Society of Chemical Industry.
March 13 . . .	Middlesbrough . . .	Cleveland Institution of Engineers.
March 29 . . .	Nottingham . . .	Nottingham Section of the Society of Chemical Industry.
April 5 . . .	Manchester . . .	Manchester Section of the Society of Chemical Industry.
April 6 . . .	Sheffield . . .	Sheffield Society of Engineers and Metallurgists.

All but one of the above meetings were addressed by the Chairman and one or more of the other members of the Committee, and the discussions which invariably followed were productive of valuable suggestions or information regarding local conditions which demand special consideration. It may be also mentioned that the Chairman lectured at the Royal Institution of Great Britain, on Thursdays, January 20, 27, and February 3 last, on 'The Utilisation of the Energy of Coal.'

In March last the Committee was asked by the newly formed Central Coal and Coke Supplies Committee of the Board of Trade to make suggestions as to economies in fuel consumption which could be made at the present time, and, as the result of further correspondence upon the matter, it was arranged that Sir Richard Redmayne should act as the representative of the Board of Trade Committee on this Committee.

During the first year of its existence the attention of the Committee has been fully occupied with questions of organisation and a preliminary survey of the ground which must be explored later on. Already several important lines of investigation needing the co-operation of manufacturers have been instituted and are well in hand. But the returns are in most cases not yet sufficiently complete to justify publication in the Report, and, in view of the importance of the interests and issues involved, the Committee feels that it would be premature to issue any detailed report on particular aspects of the fuel question until its inquiries have reached a more advanced stage than at present.

The Committee recommends that it be reappointed to continue its investigations, as outlined and foreshadowed in this Report, and, in view of the considerable expense involved in carrying out such work, it feels justified in asking for a grant of 100l.



## APPENDICES.

*The Work of the Sub-Committees.*

The following memoranda concerning the work of each of the five Sub-Committees will sufficiently indicate the various matters which are at present chiefly under consideration, and the arrangements which have been made for their future investigation.

## A.

*Chemical and Statistical Sub-Committee.*<sup>2</sup>—Dr. J. T. DUNN (Chairman), Professor P. P. BEDSON, Dr. W. GALLOWAY, Professor THOS. GRAY, Mr. T. Y. GREENER, Professor L. T. O'SHEA, Sir RICHARD REDMAYNE, Dr. A. STRAHAN, and Dr. R. V. WHEELER.

The Sub-Committee is preparing a memorandum and a bibliography upon the question of the chemistry of coal, and is of the opinion that the time has now arrived for a re-investigation of the subject in order to clear up a number of outstanding points connected with the chemical constituents of coal, their mutual relations in the raw material, and their influence upon the character of the various products obtainable by its distillation or oxidation. Accordingly, some of its members have undertaken experimental work, partly on new lines and partly by way of check repetition, with the object of providing a basis for a more complete attack upon the subject in the near future. A group of research assistants is already working on the problem under Professor Bone's direction in the Department of Chemical Technology of the Imperial College of Science and Technology, London.

As an important part of the work, the Sub-Committee hopes later on to organise systematic investigations upon the chemical character of the principal British coal seams. Such an undertaking would, however, involve considerable labour and expense, and the prospect of achieving any useful result will depend entirely on the amount of funds which may be forthcoming in support. The Sub-Committee is of the opinion that the resources both of existing laboratories which have been established within recent years in this country for the special investigation of fuel problems, and of other laboratories where the technique of the subject has been developed, might be utilised more than they are at present in this connection, and that the time is ripe for the organisation of a scheme of systematic co-operative research, aided by national funds, in which all such laboratories may participate.

The Sub-Committee is also compiling statistical information relative to the different purposes for which coal is used, and has entered into communication with the Board of Trade upon the question, but the collection and analysis of such statistics has been greatly impeded by the war.

Another important matter into which the Sub-Committee proposes to inquire is the amount of wastage due to coal which, for one reason or another, is at present left behind in the pits. Part of such wastage,

<sup>2</sup> The Chairman and Secretary of the General Committee are *ex officio* members of each Sub-Committee.

for example that due to the occurrence of faults in the coalfields, is unavoidable, but when all such allowance has been made, there undoubtedly remains a large wastage in working which might be and ought to be avoided. A memorandum is being prepared on the reduction of such wastage by the adoption of hydraulic stowing, a practice which, although in vogue on the Continent, has not yet been established in Great Britain.

## B.

*Carbonisation Sub-Committee.*—Mr. T. Y. GREENER (Chairman), Professor P. P. BEDSON, Sir G. T. BEILBY, Mr. E. BURY, Dr. CHARLES CARPENTER, Dr. J. T. DUNN, Professor THOS. GRAY, Mr. D. H. HELPS, Mr. C. H. MERZ, Professor L. T. O'SHEA, Dr. J. E. STEAD, Mr. G. BLAKE WALKER, and Dr. R. V. WHEELER.

The total amount of coal carbonised in this Kingdom for the manufacture of metallurgical coke or for towns' gas in the year 1913 was probably about thirty-five to forty million tons, or approximately one-fifth of the total home consumption of coal for all purposes.

According to a recent Parliamentary Return relating to all Authorised Gas Undertakings in the United Kingdom, the total quantity of coal carbonised for towns' gas by 831 such undertakings in the year 1913 amounted to 16,971,724 tons, from which 195,826 million cubic feet of coal gas were produced, or say, on the average, about 11,500 cubic feet per ton of coal carbonised. There are a number of gasworks not included in this Parliamentary Return, and it is computed that they carbonise about one and a quarter million tons of coal per annum. Thus the total coal carbonised in gasworks throughout the Kingdom in the year 1913 would be about 18,200,000 tons.

The amount of ammonium sulphate produced by gasworks in that time in the United Kingdom was officially given as 182,180 tons, which on the above basis would represent an average yield of about 22.4 pounds per ton of coal carbonised.

No such complete returns are available in relation to the manufacture of metallurgical coke, but the amount of coal carbonised for this purpose in 1913 probably did not fall much short of twenty million tons. Of this coal, the larger proportion was carbonised in by-product ovens, producing, besides coke, tar, benzol, &c., some 133,816 tons of ammonium sulphate. Assuming an average yield of 22.5 pounds of ammonium sulphate per ton of coal, it would appear that approximately 13.3 million tons were carbonised in by-product ovens, and probably about half that amount in bee-hive ovens.

With regard to the coking industry, the Sub-Committee has already undertaken steps to secure a complete return of the number of by-product recovery ovens installed and working throughout the country, the character of each installation (whether waste heat or regenerative), its coking capacity, the description of the recovery plant connected with it (whether direct or indirect), the number of benzol recovery plants in operation, the quantities and yields of the by-products obtainable, and the purposes for which waste heat and surplus gas are being

employed. When completed, this return will enable the Committee to arrive at an approximate estimate of the margins of possible economies in the shape of improved utilisation of the coal carbonised which can now be effected in the coking industry and the directions in which further progress is likely to be made.

A memorandum is also in course of preparation describing the more important developments of the by-product coking industry, from its inception until the present day.

With regard to gasworks practice, inquiries have been instituted regarding the present practice in connection with the manufacture of towns' gas, and for this purpose the Institution of Gas Engineers is officially represented on the Sub-Committee. It is also intended later on to consider the question of low-temperature carbonisation from the point of view of its possible economic results, but up to the present time so little authentic information is available that the Committee would welcome the offer of proper facilities to enable them to investigate the matter.

### C.

*Metallurgical, Ceramic, and Refractory Materials Sub-Committee.*—Dr. J. E. STEAD (Chairman), Mr. ROBERT ARMITAGE, M.P., Professor J. O. ARNOLD, Sir HUGH BELL, Bart., Mr. E. BURY, Sir ROBERT HADFIELD, Mr. GREVILLE JONES, Dr. J. W. MELLOR, Mr. ROBERT MOND, Mr. BERNARD MOORE, Mr. BENJAMIN TALBOT, Mr. B. W. WINDER, and Mr. H. JAMES YATES.

The amount of coal consumed in metallurgical, ceramic, refractory materials, and cognate industries probably amounts to approximately 20 per cent. of the total home consumption. Of this, probably about three-fourths must be debited to the iron and steel industries.

The Sub-Committee has taken steps to ascertain from some of the larger manufacturers data which will assist it in determining the actual amount of fuel which is being used on the average in the manufacture of the various brands of pig iron, spiegeleisen, ferro-manganese, &c., throughout the Kingdom. A memorandum is in preparation concerning the heat balance of a blast furnace of modern construction for the manufacture of Cleveland No. 3 and other pig irons, and a description will be given of the best methods now available for the utilisation of the surplus gases from such a furnace. Inquiries are also being made as to the results of the application of dry air to blast furnaces.

In like manner a series of questions relative to fuel consumptions in steelworks has been prepared for circulation among the larger steel plants in the Kingdom, with a view to ascertaining both the present average consumption and the directions in which further economies may be looked for in the near future. In this connection the Sub-Committee will endeavour to draw up a statement as to the best lay-out and arrangement of a combined by-product coking, iron-smelting, and steel-making plant from the point of view of utilising as completely as possible surplus gases and waste heat, and thus realising the maximum fuel economy in the heavy-steel industry.

Similar inquiries will be instituted in regard to present-day practice and results in relation to (1) iron foundries, (2) manufacture of wrought iron, and (3) specialised steel industries.

Two members of the Sub-Committee specially connected with the ceramic industry have undertaken to prepare a memorandum showing the average present practice and the possible margins of fuel economy in relation to that industry, and information is invited by the Sub-Committee relative to glassworks and brickworks.

The Sub-Committee desires to state that all information communicated to it by individual manufacturers will be regarded as confidential,<sup>3</sup> and will be used merely as a basis for arriving at an approximate estimate of the present average fuel consumption per unit of output in the particular industry to which the information relates.

#### D.

*Power and Steam Raising Sub-Committee.*—Mr. C. H. MERZ (Chairman), Lord ALLERTON, Mr. J. A. F. ASPINALL, Dr. DUGALD CLERK, Mr. S. Z. DE FERRANTI, Sir ROBERT HADFIELD, Dr. H. S. HELE-SHAW, Mr. W. W. LACKIE, Mr. MICHAEL LONGRIDGE, Mr. ROBERT MOND, Hon. Sir CHARLES PARSONS, Professor RIPPER, Mr. R. P. SLOAN, Mr. C. E. STROMEYER, Professor THRELFALL, Mr. G. BLAKE WALKER, and Mr. B. W. WOODHOUSE.

The special duty of this Sub-Committee is to investigate the economies in fuel which would result from the use of improved methods, and it has been decided to deal with the subject under the following heads:—

- (1) To consider (a) the amount of fuel consumed, and (b) the corresponding power developed in the United Kingdom under the following heads: Factories, Mines, Railways, Ships, and Steam Raising for other purposes than power.
- (2) To consider the present position of central electrical power plants and gas undertakings as regards power supply.
- (3) To discuss the relative merits of the present methods for producing power by steam, gas, oil, and petrol engines respectively.
- (4) To investigate the possible saving of fuel which might be effected (a) by improved plant, (b) by greater centralisation of power production, (c) by co-ordination with metallurgical and other manufacturing processes, (d) by some measure of public control, (e) by better supervision, and (f) by the use of inferior grades of fuel which are at present wasted.

While, on account of the magnitude of the subject and the amount of investigation involved, it is not possible at present to submit any

<sup>3</sup> It is suggested that all such information should be sent in the first instance to Professor Bone (Chairman of the General Committee), at the Imperial College of Science and Technology, London, who will classify and summarise it under either alphabetical letters or numerals in such a way that the names of the manufacturers or firms concerned will not be divulged to any of the members of the Committee.

report, it may be mentioned that information has been sought as to the amount of fuel consumed and the corresponding power developed in such official publications as the Report of the Royal Commission on Coal Supplies in 1905, the Census of Production for the year 1907, and the Returns published annually by the Home Office for Mines and Quarries, and various Shipping and Customs Reports. But although, from such sources, fairly accurate figures can be obtained for the amount of coal used annually for industrial purposes and shipping, the corresponding figures of power produced are not obtainable from any published returns so far as can be ascertained.

The average figure of five pounds of coal per horse-power hour which was given in the Report of the Royal Commission on Coal Supplies in 1905 was, we believe, deduced from returns from a number of typical industrial concerns where information could be obtained, and it is probable that this estimate did not exaggerate the actual coal consumption per horse-power hour at that time.

In view of the impossibility of obtaining accurate returns of fuel consumption per horse-power hour from the whole of the power users in this country, it has been decided to investigate the matter by asking for detailed returns from typical factories in various trades and in different districts throughout the country, selected by members of the Sub-Committee who have special knowledge of particular trades.

Special memoranda are in course of preparation on questions of organisation of power production for industrial and transport purposes, the use of large turbine and gas engines, and other important aspects of the power question.

### E.

*Domestic Fuel Sub-Committee.*—Mr. E. D. SIMON (Chairman), Mr. A. H. BARKER, Professor H. B. DIXON, Professor W. W. HALDANE GEE, Professor W. P. WYNNE, and Mr. H. JAMES YATES.

The amount of coal actually consumed for domestic purposes in the United Kingdom probably does not fall far short of thirty-six million tons per annum—nearly one-fifth of the total consumption for all purposes in the Kingdom. To this would have to be added the 'coal equivalent' of the gas and electricity consumed for domestic purposes, if a correct estimate of the total domestic coal consumption is to be made. The Royal Commission of 1905 estimated that 50 per cent. of the coal consumed for domestic purposes might be saved by the installation of better appliances, so that there is clearly a vast field for economy.

The whole question of domestic uses of fuel bristles with difficulties and complications. In the first place, it is necessary to discriminate between fuel or energy consumed in the kitchen for cooking and other similar purposes, and that applied for the heating of ordinary living-rooms.

In the vast majority of the houses inhabited by the artisan population the kitchen fire or stove is the only place in the house where fuel is burnt; also in better-class houses it is only in the kitchen that fuel

is burnt daily throughout the whole year. Hence it would appear that the kitchen is responsible for the greater part of our annual domestic fuel bill, and, therefore, the question of the relative efficiencies of kitchen ranges, gas and electric cookers, and hot-water supply apparatus assumes considerable importance.

Again, the selection or recommendation of particular means or apparatus for domestic heating cannot always be based simply upon the question of thermal efficiency, because it also involves considerations of a physiological and even of a psychological character. Thus, for example, systems of central heating which have been recommended on grounds chiefly of thermal efficiency, and which are so universally used in America and on the Continent, are not usually acceptable to the average Englishman, who undoubtedly prefers to be warmed by the radiation from a bright fire.

This being so, the Sub-Committee feels that it will be wise to recognise at the outset that there is probably no single solution of the domestic heating problem which is likely to be universally adopted within any measurable period of time; and that, therefore, it should preferably concentrate its efforts upon questions of more immediate practical importance.

It will be generally agreed that any reform in domestic fuel consumption should aim at achieving one or more of the following objects, namely:—

- (1) Actual reduction in cost of domestic heating, either in the form of direct saving of fuel or labour, or both;
- (2) Mitigation or abolition of the domestic smoke nuisance; and
- (3) Better hygienic conditions in living-apartments generally.

The Sub-Committee can perhaps best discharge its duties by considering how far the various systems now available for domestic heating fulfil such requirements, and how they may severally be installed and operated to the best advantage.

In order to do this the Sub-Committee has arranged for experiments to be carried out with the object of determining how to produce in a given room suitably warm and healthy conditions at a minimum cost and with a minimum production of smoke, and how such conditions may be defined for any particular room. Also, experimental work is being carried out upon the relative efficiencies of coal fires, gas fires, electric heaters, and the like.

Inasmuch, however, as in this country the use of the open coal fire will probably continue for some time to come, and as there are undoubtedly great economies to be immediately realised by the wider adoption of improved fire-grates, the Sub-Committee will pay special attention to the question of improvements in the construction and installation of such grates, to which the attention of architects, builders, and the public generally ought to be drawn.

Arising out of the present extensive use of solid fuel in domestic fires, the Sub-Committee will also consider the important question of the prospects of substituting for raw coal some form of carbonised fuel

(semi-coke or coke). There can be no doubt but that if such a substitution could be effected, without either increasing the domestic coal bill or involving some other disadvantage, not only would there be a great addition to the amount of valuable by-products annually obtained from coal consumed in the Kingdom, but also the smoke nuisance in our large centres of population would be materially reduced.

Work on these lines is being carried out in the Department of Heating and Ventilating Engineering at the University College, London, at the Municipal School of Technology, Manchester, and at the Department of Chemical Technology at the Imperial College of Science and Technology, London.

*The Botanical and Chemical Characters of the Eucalypts and their Correlation.*—*Second Report of the Committee, consisting of Professor H. E. ARMSTRONG (Chairman), Mr. H. G. SMITH (Secretary), Mr. E. C. ANDREWS, Mr. R. T. BAKER, Professor F. O. BOWER, Mr. R. H. CABBAGE, Professors A. J. EWART and C. E. FAWSITT, Dr. HEBER GREEN, Dr. CUTHBERT HALL, Mr. J. MCLUCKIE, Professors ORME MASSON, E. H. RENNIE, and R. ROBINSON, and Mr. P. R. H. ST. JOHN.*

[PLATE II.]

DURING the year the Committee has held three meetings in Sydney, at which methods of procedure and results were discussed.

Mr. John McLuckie, M.A., B.Sc., of the Botanical Department, Sydney University, was added to the Committee.

Much of the official year had passed away before the Committee in Australia knew that its first Report had been accepted for printing and that the Committee had been reappointed with a grant of £30.

The serious drain on the young Australian scientists caused by the war has also been a factor in preventing the completion of certain work which it is considered desirable should be undertaken, so that no claim is made in the present Report upon the grant. The Committee ask to be reappointed, and that at least the sum allocated to them last year may again be placed at their disposal.

Work has been done during the year on

- (a) the phenols in Eucalyptus oils;
- (b) the variation in the amounts of the constituents of Eucalyptus oils;
- (c) *Eucalyptus Australiana* and its peculiarities.

(a) *The Phenols in Eucalyptus Oils.*

In the first Report it was stated that two distinct phenols were present in Eucalyptus oils (No. 10 in previous Bibliography), though only in very small quantities.

One of these phenols, *Tasmanol*, has now been isolated from the

oils in several species of the 'peppermint' and 'ashes' groups. Tasmanol is a liquid; it contains a methoxy-group and gives a characteristic colour with ferric chloride. It is usually associated with the ketone piperitone. The prepared oils from all the members of the groups mentioned are water-white, so that a possible reason is suggested for the occurrence of the two classes of *Eucalyptus* oils, those which are colourless and those tinged yellow.

The botanical characters of the species yielding oils which contain Tasmanol are also in agreement with this chemical character; thus the anthers are kidney-shaped (*Renantheræ*); the lanceolate leaves have the venation type 3,\* the timbers are white in colour, while the persistent portion of the fibrous barks is either that known as 'peppermint' or allied to this; the kinos contain neither Eudesmin nor Aromadendrin.

The presence or absence of cineol in the oils appears to have no directing influence, as oils equally rich in cineol may contain either phenol or perhaps both.

The second phenol, which occurs in the other large group of oils, has now been isolated in sufficient quantity to demonstrate its crystalline form. The accompanying photograph shows the crystals of natural size. These crystals were obtained from the phenol extracted from about 60 lb. of the crude oil of *Eucalyptus Woollsiana*.

It would be necessary to treat several hundreds of pounds of oil of the appropriate species to obtain sufficient of this crystallisable phenol to enable its chemical composition to be determined. It does not, so far, appear that it contains a methoxy-group; in this respect it differs from Tasmanol.

The crystallisable phenol is associated with the aldehyde Aromadendral in the oils of the typical 'Boxes,' the group to which *Eucalyptus Woollsiana* belongs; piperitone is absent; it possibly occurs also in the cineol-pinene oils from which both the ketone and the aldehyde are absent or only present in traces.

(b) *The Variation in the Amount of Constituents in Eucalyptus Oils in Material of Various Ages.*

There has long been some uncertainty on this point; it is now recognised, however, that the various products from particular species of *Eucalyptus* are remarkably constant from a chemical point of view, so much so that botanical diagnosis is assisted by their determination.

Differences in the amounts of the oily constituents of particular species are, however, to be expected, although in the case of *Eucalyptus* the variation is but slight, particularly when the material has been collected as for ordinary distillation. This fact is now recognised commercially and standards have been founded upon it.

*Eucalyptus Smithii*, the species chosen for these experiments, affords results from which a very good idea can be formed of the extent of variation to be expected in oils from trees of different ages.

\* These types of venation are illustrated in the first Report.





Crystallised Phenol from the Oil of *Eucalyptus Woolfsiana*.



The oil from this species of Eucalyptus belongs to the cineol-pinene group and the leaf has a venation of type 2. The oil contains cineol in larger amount, perhaps, than is found in that of any other species and has a less percentage amount of the constituents which are generally considered of an objectionable nature, as, for instance, the aldehydes, sesquiterpenes, &c.

The following tables illustrate the rate of diminution of the terpene and the corresponding increase in cineol as the trees grow older; but it may be observed that the figures published fourteen years ago for the oil of this species agree most closely with those now given for general material, although the foliage was collected over a hundred miles from the locality where the later material was gathered.

Extended data as well as numerous illustrations are given in the 'Journal of the Royal Society of New South Wales,' August 1915.

TABLE I.

- (a) Leaves from lopped trees, seven months' growth; collected May 1913.  
 (b) Leaves from lopped trees, fifteen months' growth; collected May 1913.  
 (c) Leaves from seedlings, twelve months' growth; collected June 1914.  
 (d) Leaves from seedlings two and a half years old; collected July 1914.  
 (e) Leaves from cultivated tree at Marrickville; collected June 1915.  
 (f) Leaves from general material, partly young; collected January 1915.  
 (g) Leaves from general material; collected three weeks later than (f).  
 (h) Leaves from old trees; collected March 1913.

The constants, &c., given by the crude oils from the above material were as follow:—

TABLE II.

—	Specific Gravity at 15° C.	Rotation $\alpha_D$	Refractive Index	Solubility in 70 per Cent. Alcohol	Saponification Number	Cineol per Cent.
(a)	0.9098	+ 7.6°	1.4636 at 20°	Required 1.6 vols.	4.8	67.4
(b)	0.9157	+ 6.5°	1.4635 at 20°	1.2 „	5.6	74.2
(c)	0.9116	+ 9.2°	1.4650 at 19°	2.1 „	1.3	61.5
(d)	0.9139	+ 7.6°	1.4634 at 18°	1.4 „	4.1	69.0
(e)	0.9198	+ 4.1°	1.4672 at 16°	1.2 „	2.7	75.0
(f)	0.9156	+ 5.3°	1.4571 at 26°	1.1 „	3.3	80.7
(g)	0.9154	+ 5.1°	1.4574 at 25°	1.1 „	3.1	79.0
(h)	0.9210	+ 4.2°	1.4604 at 22°	1.1 „	1.3	85.2

The cineol was determined by the resorcinol method, in all cases in the redistilled portion of the freshly obtained oil boiling below 190°. The alcohol for solubilities was 70 per cent. by weight.

(c) 'Eucalyptus Australiana' (*sp. nov.*) and its Peculiarities.

This species is plentifully distributed in New South Wales and Victoria. It is known vernacularly as 'Black peppermint,' 'Narrow-leaf peppermint' and also as 'Messmate.' Although morphologically this tree shows great resemblance to *Eucalyptus amygdalina* of Tasmania, yet the two trees are not identical. The yield of oil given by the Australian trees is remarkably high, sometimes reaching as high as 4½ per cent., from leaves with terminal branchlets. This oil has abnormal characters, due largely to the presence of an alcohol, of high boiling point, at present undetermined; the amount of this alcohol appears to be fairly constant. Phellandrene, which is present to a pronounced extent in the oil from higher altitudes, diminishes considerably in amount when the species grows naturally at a lower level, the cineol increasing correspondingly in amount. It was discovered several years ago that the cineol content of the oil from this species could be raised if the oil were fractionally separated when the leaves were being distilled. This fact has now commercial value and much of the water-white Eucalyptus oil containing about 70 per cent. cineol, which has recently reached the London market, has been prepared from this species in this way, the oil coming over during the first hour being sold as a pharmaceutical oil, that which distils later being used for other commercial purposes. It has been found that this 'first-hour oil' is remarkably constant in general characters; numerous analyses, made in Sydney, show that if separated at the first hour the figures have the following range:—

Relative density at 15° C. = 0·9179 to 0·9211.

Rotation  $\alpha_D = 1\cdot3^\circ$  to  $+1\cdot7^\circ$ .

Solubility in 70 per cent. alcohol 1·05 to 1·15 volumes.

Refractive index at 20° C. = 1·4614 to 1·4636.

Analyses of the second-hour oil gave 11·4 as saponification number for the ester and 95·1 for the acetylated oil. In the case of the third-hour oil the figures were 9·4 and 124·5 respectively.

It is very probable that this species of Eucalyptus will eventually become of even greater economic importance as an oil-producing plant than it is at the present time. (For further information see 'Journal of the Royal Society of New South Wales,' December 1915.)

Besides this species a few others have been described recently and named by Mr. Maiden, but the products these gave have not yet been chemically examined.

*Brown Coal.—Report of the Committee, consisting of Professor ORME MASSON (Chairman), Mr. P. G. W. BAYLY (Secretary), and Mr. D. AVERY, on the Utilisation of Brown Coal Bye-Products.*

OWING to pressure of work arising out of war conditions, no further work has been done in connection with experiments in the utilisation of brown coal.

The work will, however, be set in hand at an early date, as the importance of the investigation is emphasised by the necessity for developing our raw products.

The deposits of brown coal in Victoria (Australia) are enormous, covering several hundreds of square miles and varying in thickness up to 800 feet.

The analysis of the coal may be taken as

H <sub>2</sub> O	.	.	.	.	.	.	.	Per cent.
V.H.C.	.	.	.	.	.	.	.	53.00
F.C.	.	.	.	.	.	.	.	24.50
Ash	.	.	.	.	.	.	.	21.50
								1.00
								100.00
Nitrogen	.	.	.	.	.	.	.	0.30

The recovered distillation products are:—

(1) Ammonium sulphate	.	.	.	.	.	30 lb. per ton.
(2) Tar	.	.	.	.	.	68.5 lb. per ton.
(3) Gas, 360 B.T.U.	.	.	.	.	.	9,140 cubic feet.
(4) Carbonaceous residue	.	.	.	.	.	560 lbs.

The experiments in hand deal with the best form of retort or generator, and the examination of the tar for various oils and paraffins. The question of briquetting will also be reviewed.

---

*The Old Red Sandstone Rocks of Kiltorcan, Ireland.—Interim Report of the Committee, consisting of Professor GRENVILLE A. J. COLE (Chairman), Professor T. JOHNSON (Secretary), Dr. J. W. EVANS, Dr. R. KIDSTON, and Dr. A. SMITH WOODWARD, appointed for the Exploration thereof.*

FOLLOWING the publication of the Interim Report made in 1915, approved sets of duplicate specimens of *Archæopteris* and *Bothrodendron* in various stages have been sent, at the receiver's expense, to educational institutions in Canada, the United States, South Africa, and New Zealand. No applications have as yet been made by museums or universities in the United Kingdom.

The most interesting addition to our knowledge of the Kiltorcan flora during the year has been the discovery of seeds and pollen-grains,

the attribution of which to *Ginkgophyllum* or some other genus is still under investigation.

The Committee asks for reappointment, with a grant of 4*l*.

*The Plant-bearing Cherts at Rhynie, Aberdeenshire.—Report of the Committee, consisting of Dr. J. HORNE (Chairman), Dr. W. MACKIE (Secretary), and Drs. J. S. FLETT, W. T. GORDON, G. HICKLING, R. KIDSTON, B. N. PEACH, and D. M. S. WATSON, appointed to excavate Critical Sections therein. (Drawn up by the Chairman and Secretary.)*

#### CONTENTS.

	PAGE
I. <i>Introduction</i> . . . . .	206
II. <i>Investigations of the Committee</i> . . . . .	209
A. <i>Record of Evidence in the Trenches</i> . . . . .	209
B. <i>Evidence from other Sections in the Area</i> . . . . .	211
i. <i>Glamlach Burn</i> . . . . .	211
ii. <i>Easaiche Burn</i> . . . . .	211
iii. <i>Roadside Section</i> . . . . .	213
III. <i>Conclusions</i> . . . . .	215
<i>Report on the Plants. By Dr. KIDSTON, F.R.S.</i> . . . . .	216

#### I. *Introduction.*

THE Rhynie Old Red Sandstone outlier was first described in detail by Sir Archibald Geikie in his comprehensive paper on 'The Old Red Sandstone of Western Europe.'<sup>1</sup> He divided the beds into the following zones in descending order:—

6. Greenish grey shales, with beds of flagstone. Dryden.
5. Thick group of hard pale grey and reddish or purplish sandstones, with occasional pebble beds, and numerous pipes, 'galls,' and irregular veinings of red clay. Rhynie quarries, Burn of Craig, about 1,000 feet.
4. Band of diabase-porphyrite, seen between Contlach and Auchindoir Manse.
3. Very soft and crumbling, grey and red, pebbly sandstones, and conglomerates of well-rounded pebbles, with bands of red shale, 300 or 400 feet, seen below Glenbogie, where the valley is cut out of this soft series.
2. Red shales, with calcareous red nodules, 40 or 50 feet; seen in small ravine to east of Glenbogie.
1. Band of red and yellow conglomerate and breccia, sometimes with calcareous cement. This lowest deposit immediately underlies the shales at the last-named locality, and rests on the crystalline rocks.

The highest division (Dryden Flags) is practically the only one that falls within the scope of this report.

The beds of the Rhynie outlier are seen to lie unconformably on the igneous rocks (diorites and granites), and the members of the metamorphic series of West Aberdeenshire along the eastern margin of the area, and to dip at fairly uniform angles of 15° to 20° to the west, where they are cut off by a fault running north and south which throws down the whole series against the clay-slates, grits, and diorites on the west.

<sup>1</sup> *Trans. Roy. Soc.* vol. xxviii. p. 423.

The area was surveyed in detail by the Geological Survey, and the results, which confirm the conclusions previously arrived at by Sir Archibald Geikie as to the order of succession of the strata, are represented in the one-inch map (Sheet 76) published in 1886, and are briefly described in the explanatory memoir to that sheet published in 1890. The classification adopted in the memoir is given below<sup>2</sup>:—

- (5) Dryden flags and shales.
- (4) Quarryhill sandstones.
- (3) Tillybrachty sandstones with volcanic zone.
- (2) Lower red shales with calcareous bands.
- (1) Basal breccia and conglomerate.

Early in 1910 Dr. Mackie became aware that a narrow strip of sedimentary and volcanic rocks occurs to the west of the boundary fault as laid down on the Geological Survey Map (Sheet 76). This strip is situated about a quarter to half a mile due west of the village of the Muir of Rhynie, and extends both north and south of the Rhynie and Cabrach road. These beds present a much more ancient-looking facies than the Old Red Sandstone strata east of the fault, and were found on examination in detail to include cherts, silicified grits and conglomerates, together with a very acid andesite or rhyolite, which also shows silicification in places. The results were described by Dr. Mackie in a preliminary paper communicated to the British Association at the Dundee meeting in 1912,<sup>3</sup> and in greater detail in a paper read before the Edinburgh Geological Society in November 1913.<sup>4</sup> In addition to the series there described, Dr. Mackie brought to light a distinct band of volcanic ash just above the rhyolite and between it and the 'Upper Grit' of the same series. Late in 1912—too late for inclusion in the British Association paper—numerous blocks of a fine black chert were discovered by Dr. Mackie lying loose on the surface or built into the stone dykes along the sides of the adjacent fields. These appeared to radiate from a centre about seventy-five yards east of the bend of the road leading to Windyfield farmhouse. They were traced eastward for about three hundred yards, but up to that time they had nowhere been found in place. Their cherty character was at first the main point of interest, and for that reason, in the absence of field evidence of their stratigraphical position, they were naturally supposed to belong to the silicified 'Older Series' to the west of the Old Red Sandstone boundary fault. Between the date indicated and October 1913 numerous micro-sections of the chert were examined by Dr. Mackie, which proved to be exceptionally rich in plant remains in a remarkably perfect state of preservation. These were at once placed in the hands of Dr. Kidston for description in detail, and a brief account of them drawn up by him is appended to this report. Dr. Mackie believes that the microscopic sections of the plant-bearing cherts also show remains of small crustacea, which are still under investigation.

<sup>2</sup> Explanation of Sheet 76 (*Mem. Geol. Sur.*), p. 27.

<sup>3</sup> *British Assoc. Report*, Dundee 1912, p. 467.

<sup>4</sup> 'The Rock Series of Craigbeg and Ord Hill, Rhynie, Aberdeenshire,' *Trans. Edin. Geol. Soc.* vol. x. part 2, p. 205.

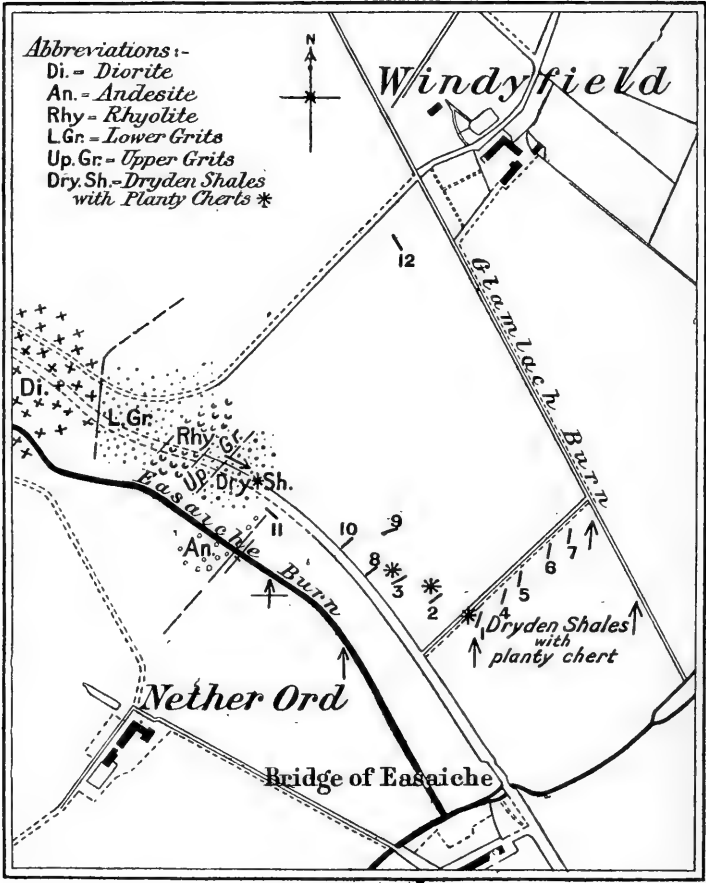

*Explanation of Signs*  
 ← Dip of strata.    X Highly inclined strata,    — Vertical strata  
 - - - - - Faults shown thus

FIG. 1.—Map showing the sites of the trenches 1 to 12, and position of the roadside section at Craigbeg.



In October 1913, Mr. D. Tait, of the Geological Survey, at the instance of the Assistant-Director, Dr. Flett, visited the area and made several excavations with the view of fixing definitely the stratigraphical position of these plant-bearing cherts. He proved their position within the Old Red Sandstone area and about two hundred yards east of the boundary fault, as laid down in the Geological Survey Map (Sheet 76). The main locality is in the position of Trench No. 1 of the accompanying map (Fig. 1). His results are summarised in his report, which is quoted in Dr. Mackie's paper communicated to the Edinburgh Geological Society.<sup>5</sup> His conclusion was that these plant-bearing cherts belonged to the Old Red Sandstone. For reasons given in the paper referred to, Dr. Mackie could not accept that conclusion, and the present investigation was undertaken with the view of determining the exact stratigraphical position of the plant-bearing cherts.

## II. *Investigations of the Committee.*

As the field of investigation lies almost wholly on agricultural land, the trenches had to be covered up by the end of March 1916. The work was much interrupted by unfavourable weather. Fortunately only a small part of the work as originally planned was not carried out. The Committee hope to be able to overtake the remainder in the late autumn of this year or nearly next spring, with the aid of a grant from the Royal Society. The work was conducted throughout under the personal supervision of Mr. Tait, of the Geological Survey.

The area of investigation lies to the west of the village of Muir of Rhynie. About a quarter of a mile from the centre of the village, and about a hundred yards to the N.W. of the bridge of the Easaiche Burn (see fig. 1), a small ditch between two fields occurs on the N.E. side of the road. This ditch was made the datum line for measurement from the road in a northern direction, while the road itself from the end of the ditch was made the line of measurement in an east and west direction. As many blocks of the chert were found lying along the margins of this ditch, it was cleared out and the rocks in place were exposed at a distance of about fifty yards N.E. from the road. The chert band was found in the ditch. A bed of clay was also found below it. The section in the ditch remains as a record of the work of the Committee.

### A. *Record of Evidence in the Trenches.*

The following are the records of the various trenches as drawn up by Mr. Tait. Their positions are indicated on the accompanying map (fig. 1):—

*Trench No. 1.*—In first field north of Easaiche Bridge, on south-east side of path and ditch separating the two fields, and 178 feet north-east of road. This trench is 38 feet long and about 3 feet wide. Its greatest depth is  $6\frac{1}{2}$  feet. The plant-bearing chert, which is about 8 feet in thickness, projects upwards to within 6 inches of the surface of the field and dips at an angle of  $45^{\circ}$  to the north.

<sup>5</sup> 'The Rock Series of Craigbeg and Ord Hill, Rhynie, Aberdeenshire,' *Trans. Edin. Geol. Soc.* vol. x. part 2, p. 223.

Soil and subsoil varies from 6 inches to 6½ feet (thickness).<sup>6</sup>

	Feet	Inches
O— (1) Cherty sandstone with carbonaceous fragments . . . . .	—	5
N— (2) Cherty sandstone with lenticles of chert . . . . .	—	6
M— (3) Chert with thin bands of sandstone . . . . .	—	9
L— (4) Chert with sandy layers . . . . .	1	—
K— (5) Bedded cherty sandstone . . . . .	—	3
I— (6) Sandy chert, lenticular . . . . .	—	3
H— (7) Bedded cherty sandstone, dark-coloured . . . . .	—	1
G— (8) Chert . . . . .	—	3
F— (9) Sandy chert . . . . .	—	5
E— (10) Chert . . . . .	1	1
D— (11) Cherty sandstone, dark-coloured . . . . .	—	3
C— (12) Clayey shale . . . . .	—	3
B— (13) Chert . . . . .	—	9
A'— (14) Dark cherty sandstone with carbonaceous markings . . . . .	—	6
A''— (15) Chert . . . . .	1	3
(16) Grey clay . . . . .	—	1
(17) White plastic clay, greenish tint and rusty spots, bedding obscure, but more distinct near bottom . . . . .	2	—
(18) Clay or clayey shale not so light in colour as that above . . . . .	2	—

Trench No. 2.—Lower trench in upper field (second field) north of Easaiche Bridge.

	Feet	Inches		Feet	Inches
Surface . . . . .	3	—	Chert blocks, fractured and		
Yellow clay, ? in place . . . . .	2	—	confused . . . . .	?	—
Solid bed of chert, 2-3 feet . . . . .	3	—	Light-coloured clay . . . . .	?	—

Dips of 50° to 60° to the north-east were indicated.

Trench No. 3.—Section in trench in upper field (second field), north of Easaiche Bridge, 70 feet north-east of road, and 180 feet north-west of the ditch separating the lower from the upper field.

	Thickness*	
	Feet	Inches
Surface material . . . . .	4	—
(1) Greenish-yellow clay . . . . .	1	—
(2) Red ochrey clay . . . . .	—	4
(3) Sandy chert and cherty sandstone in beds 1" to 2" and in small pieces . . . . .	1	—
(4) Greyish shale with pale and yellow bands . . . . .	3	—
(5) Yellowish clayey shale with grey bedding lines . . . . .	2	—
(6) Yellow plastic clay, ochrey at base, bedding obscure . . . . .	1	—
(7) Banded dark-grey and yellow clayey shale, micaceous . . . . .	2	—
(8) Hard, dark-brown, well-bedded sandstone with carbon- aceous films on bedding planes, and with blebs of black chert often ¼ inch in size . . . . .	—	-10
(9) Chert, lenticular, with plant remains . . . . .	—	-5
(10) Dark cherty sandstone . . . . .	—	-8
(11) Dark carbonaceous shale, micaceous . . . . .	1	9
(12) Chert with plant remains and dark cherty sandstone . . . . .	—	-6
(13) Cherty sandstone, much broken . . . . .	—	-10
(14) Chert with plant remains . . . . .	—	-3
(15) Chert, much broken, sandy . . . . .	—	-5
(16) Solid, massive bed of chert with brecciated internal structure . . . . .	2	6
Loose blocks of chert not <i>in situ</i> at greater depth . . . . .	—	?

Dips 50° to 55° to the east-north-east.

\* The capital letters A to O in the section of Trench No. 1 have been used by Dr. Kidston and Professor Lang to indicate the various sub-zones of the chert, in their joint paper 'On Old Red Sandstone Plants showing Structure from the Rhynie Chert Bed, Aberdeenshire,' communicated to the Royal Society of Edinburgh on July 3, 1916.

*Trench No. 4.*—In first field north of Easaiche Bridge, on south-east side of ditch, and 250 feet north-east of road.

A greenish and yellowish clayey and micaceous shale, with brown bands, was met with at a depth of 8 feet. This was weathered into a soft material that could be dug with a spade. The bedding planes indicated a dip to the north at  $35^{\circ}$ .

*Trench No. 5.*—In first field north of Easaiche Bridge, on south-east side of ditch, and 300 feet north-east of the road. This trench was 6 feet deep. At its north end, near the bottom, reddish clayey shale was found; at its south end, greenish shale. The rock was very much decomposed, but the fragments, often flat or lenticular in shape, dipped to the north. The section was not a good one, but there is little doubt that this material is *in situ* here.

*Trench No. 6.*—In first field north of Easaiche Bridge, on south-east side of ditch, and 400 feet north-east of road. This trench went to a depth of 8 feet, but no solid rock was reached. A gravelly sand was found at the bottom.

*Trench No. 7.*—In first field north of Easaiche Bridge, on south-east side of ditch, and 475 feet north-east of road. This trench went to a depth of about 5 feet. Brownish and greenish thin-bedded shale with a dip to the north was found in it.

*Trenches Nos. 8, 9, 10, 11* (sites as on map).—These trenches varied in depth from  $6\frac{1}{2}$  feet to 9 feet. No rock was met with in any of them.

*Trench No. 12.*—In north-east corner of field close to Windyfield farmhouse. A yellowish-green flaky sandstone was met with at about 7 feet from the surface. The dip was probably to the south-south-east.<sup>7</sup> A snowstorm interrupted operations, and the section was never clearly exposed.

## B. Evidence from other Sections in the Area.

### i. Glamlach Burn Section.

In the Glamlach Burn (fig. 1), on the north-east side of the field in which trenches 1, 4, 5, 6, and 7 were dug, there is a continuous section of shales and fine sandy flags, extending from the north end of the Cross Ditch down to within a few yards of the junction of the Glamlach Burn with the Easaiche Burn. The beds dip to the north at angles of about  $30^{\circ}$ , and belong to the Dryden Flag group. They overlie the plant-bearing cherts and associated strata exposed in trenches 1 and 2.

### ii. Easaiche Burn Section.

A few rock exposures occur in the Easaiche Burn (fig. 1), to the south-west of the field in which the trenches have been dug, at two localities—one about 400 feet, the other about 200 feet from the base line of the Cross Ditch. Flaggy sandstones cross the stream and dip with a high angle in a northerly direction. They belong to the Dryden

<sup>7</sup> As the sandstone found in this trench evidently belongs to the Dryden Flags the western boundary fault must run along the north-west side of this trench. Its exact position here has not been determined.

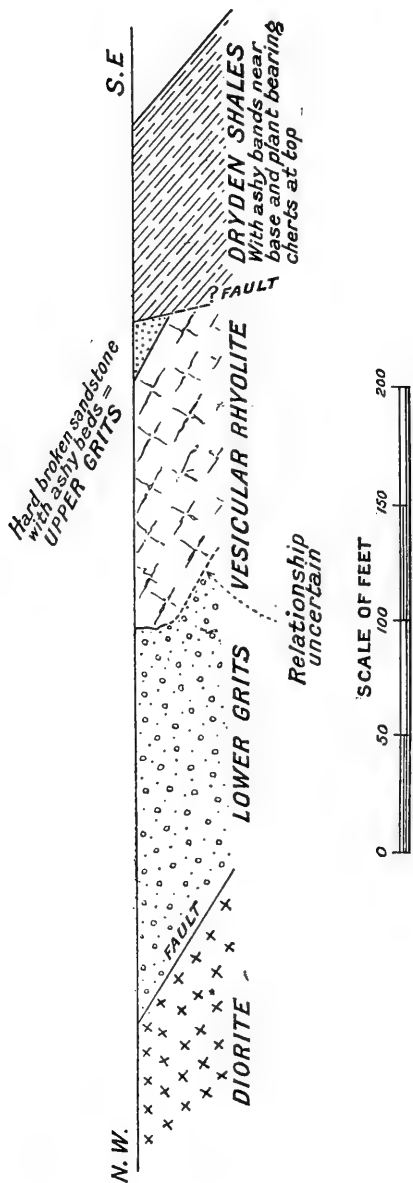

FIG. 2.—Roadside section, Craigbeg, half-mile N.W. of Rhyynie.

Flag group, and evidently underlie the plant-bearing cherts laid bare in the trenches in the field to the north-east.

Further up stream, at a point about 500 feet from the datum line, calcareous shales about 10 feet in thickness appear on the right bank, followed by flaky sandstones. The shales and sandstones are vertical, and have a north-east and south-west strike—features that suggest proximity to a fault. The strike of these beds is parallel to the trend of the boundary fault on the western margin of the Rhynie outlier of Old Red Sandstone. Immediately to the west, a band of hornblendic andesite crosses the stream. Its stratigraphical horizon is not clear, but it is referred provisionally to the Old Red Sandstone of the Rhynie outlier.

### iii. *Roadside Section, Craigbeg.*

With the sanction of the road authorities, the rocks were laid bare by the side of the road ascending Craigbeg between Rhynie and the farm of Newseat (fig. 2). On its north-east side the rocks form a steep bank, covered in part by soil and vegetation. The vegetation was removed, and a continuous rock section, 110 feet in length, was exposed. In a south-east direction, where the gradient is not so steep, this rock section ended in superficial materials. Trenches were dug to find the solid rock between this locality and trench No. 3 (the nearest point to the south-east at which rock was found), but without success owing to the covering of drift.

The interest of the roadside section centres in the following points: (1) The position of the fault between the diorite and the Craigbeg Series (the 'Older Series' of Dr. Mackie), (2) the junction of the rhyolite and the 'Lower Grits', (3) the probable position of the fault between the Old Red Sandstone of the Rhynie outlier and the 'Older Series,' and (4) the exposure of the chert band and other members of the Dryden Flag group.

Beginning at the diorite at the north-west end of the road section and descending towards Rhynie, we pass from lower to higher beds. Dips are, however, only plainly seen in the beds that overlie the rhyolite, their inclination increasing from  $25^{\circ}$  to about  $40^{\circ}$  where the section ends.

(1) The fault between the diorite and the Craigbeg Series was located at 1,045 feet from the datum line of the Cross Ditch. Its hade is about  $33^{\circ}$  to the east. Its position is defined by a band of dark-purplish clay which was excavated at the top of the bank and at the road-level. Here the 'Slit Rock' of Dr. Mackie's succession lies against the fault plane, the basal chert of the 'Older Series' being cut out by the fault. But it appears in place at the north-east corner of the old diorite quarry about 20 yards to the north of the point indicated.

(2) South-east from the fault, the 'Lower Grits' of Dr. Mackie's succession are exposed in the bank above the road, and their junction with the overlying rhyolite was laid bare for a distance of three or four feet, about 300 yards from the datum line. The junction line is more or less vertical, but follows an irregular zig-zag course. The two rocks are welded together, and the 'Lower Grit' is bleached to a depth of about an inch at the point of contact. Dr. Flett and Dr. Campbell

D R Y D E N S H A L E S

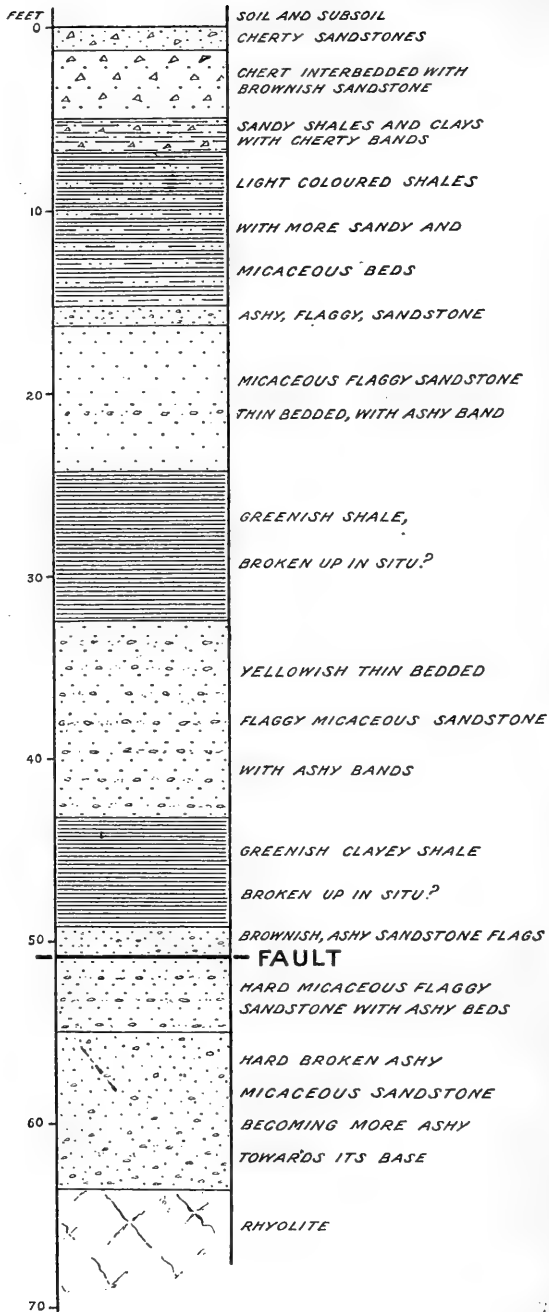

Fig. 3.—Section in N.E. bank of public road at Craigbeg between Windyfield and Nether Ord, Rhynie.

report that they have not detected any signs of contact alteration in the grit when examined under the microscope. Dr. Mackie has noted the occurrence of fine quartz veins between the two rocks in all his microscopic sections. The rhyolite weathers into a white plastic clay, with knots of less decomposed material. From its microscopic characters it may be classed as an andesite. Its outcrop along the road section measures 33 yards. It passes upwards into a band of volcanic ash with gritty partings, followed by the 'Upper Grits' of Dr. Mackie's succession, consisting of hard, flaggy, much broken, micaceous sandstones with interbedded tuffs.

(3) At the eastern margin of the 'Upper Grits' the beds are much disturbed, and there are clear indications of faulting. Dr. Mackie infers that these indications mark the position of the fault that bounds the Rhynie outlier of Old Red Sandstone on its western side.<sup>8</sup> The locality is 250 yards from the datum line and about 120 yards further to the west than the position of the fault laid down in the Geological Survey One-inch Map (Sheet 76).

(4) Eastwards beyond the boundary fault a continuous rock section was laid bare for about 20 yards. The strata exposed (fig. 3) dip to the east at angles varying from 35° to 40° and belong to the group of the Dryden Flags and Shales. They consist of greenish shales interbedded with soft, micaceous, flaggy sandstones, which contain in their lower part thin bands of tuff. Near the top of the section, bands of chert often sandy and nodular, sometimes more massive, are intercalated with these beds; one, containing plant remains, reaches a thickness of 2 feet, 3 inches. Beyond this point to the south-east excavations were made in the bank, but they failed to reach solid rock.

### III. Conclusions.

From the evidence obtained in the course of these excavations, the Committee have drawn the following conclusions:—

(1) The plant-bearing cherts found in the trenches are interbedded with the Dryden Flags and Shales, and are therefore of Old Red Sandstone age.

(2) The plant-bearing cherts exposed in the roadside section (fig. 3) are also interbedded with Dryden Flags and Shales. The band is probably the stratigraphical equivalent of the chert occurring in the trenches to the east. It contains the same plant (*Rhynia*), and rests on a similar bed of white clay.

(3) The strata exposed in the roadside section between the diorite on the west and the Dryden Flags on the east (the Craigbeg Series or the 'Older Series' of Dr. Mackie) lie between two faults, each of them having a downthrow to the east. Owing to the intense silicification which most of the rocks have undergone, their lithological characters differ considerably from those of the normal Old Red Sandstone strata of the Rhynie outlier. They may nevertheless be of Old Red Sandstone age. The precise stratigraphical horizon of these rocks has not been definitely determined.

<sup>8</sup> It is probable that there may be more than one fault on the west side of the Rhynie outlier.

The Committee, having obtained a grant for this research from the Royal Society, desire to be reappointed to carry on investigations regarding points which are still doubtful.

NOTE BY DR. MACKIE.—As the members of the 'Older Series' show locally intrusion and alteration by the younger granites of the North of Scotland, they probably represent an older stage of Old Red Sandstone than the other beds of the Rhynie outlier.

*Report on the Plants.* By DR. KIDSTON, F.R.S.

From a palæobotanical point of view the results of these investigations are of great interest and importance. A careful examination of the Rhynie chert zone has shown that it is composed of a number of peat-beds, attaining a thickness of 8 feet, whose formation was brought to a final close by infiltration with silica, supplied by geysers or fumeroles. The structure of the peat and its enclosed plants, in many cases, are preserved in great perfection. The condition of the silicified peat, so far as its structure and contents are concerned, is shown to-day very much as it existed at the time that its formation was brought to a close. The peat-beds, now the chert zone, lie on a bed of white clay, 4 feet thick, the top inch of which is a grey clay.

It contains two vascular plants, *Rhynia Gwynne-Vaughani* n. sp. and n. g., and *Asteroxylon Mackiei* n. sp. and n. g. The plants, named *Rhynia*, grew closely crowded together, and their remains formed a peat. The plant was rootless, consisting entirely of a system of cylindrical stems. Rhizomes were fixed in the peat by rhizoids, and tapering aerial stems grew up from them. These stems bore small hemispherical projections, and branched dichotomously and laterally. They had a thick-walled epidermis with stomata, and a simple central cylinder consisting of a strand of tracheides surrounded by phloem. Large cylindrical sporangia, containing numerous spores, were borne terminally on some of the leafless aerial stems. The plant is comparable with some of the specimens of *Psilophyton princeps*, figured by Dawson; and a new class of vascular cryptogams, the *Psilophytales*, is formed for their reception. This is characterised by the sporangia being borne at the ends of the branches of the stem without any relation to leaves or leaf-like organs.<sup>9</sup>

The peat is almost entirely formed of *Rhynia*, while *Asteroxylon* is of very rare occurrence.

<sup>9</sup> *Rhynia Gwynne-Vaughani* was described by Dr. R. Kidston and Professor Lang in a paper read before the Royal Society of Edinburgh on July 3, 1916. The description of *Asteroxylon Mackiei*, K. and L., is reserved for a future communication.



*Investigation of the Lower Carboniferous Flora at Gullane.—*  
*Report of the Committee, consisting of Dr. R. KIDSTON*  
*(Chairman), Dr. W. T. GORDON (Secretary), Dr. J. S. FLETT,*  
*Professor E. J. GARWOOD, Dr. J. HORNE, and Dr. B. N.*  
*PEACH.*

A NEW discovery of petrified plant-remains was made in 1914 at a point below high-water mark near Gullane, Haddingtonshire. The place could only be reached at certain states of the tide. In order to accelerate collecting, blasting operations were proposed, and a grant voted at last meeting of the Association to meet the expenses. The locality, however, lies within the area of the Forth Estuary, and, although the military and police authorities readily gave permission to blast on the foreshore, it was considered inadvisable to act on that permission meanwhile. No part of the grant was used therefore, but sufficient material has been collected to amplify considerably the data already obtained. Some 150 thin sections of the material have been prepared and examined.

The flora represented in these sections is as follows:—

<i>Lepidodendron veltheimianum</i> ,		<i>Bensonites fusiformis</i> , R. Scott.
Sternb.		<i>Pityls primæva</i> , Witham.
<i>Stigmaria ficoides</i> , Sternb.		<i>Pityls dayii</i> , sp. nov.
<i>Botryopteris (?) antiqua</i> , Kidston.		<i>Pityls</i> sp. nov.

Chief importance is attached to the specimens of *Pityls*, as so many well-preserved specimens have never been obtained elsewhere. Many of these examples had the bark preserved, while one of them consisted of a branch tip still clothed with needle-like leaves. Much light has been thrown on the stem structure of the genus, while the details of the connexion of leaf and stem have also been determined.

As regards the other plant types represented, it is interesting to note the similarity between the whole assemblage and the flora of the Pettycur Limestone at Pettycur, Fife. Indeed, the form *Bensonites fusiformis*, R. Scott, has not, so far, been recorded except from Pettycur. Both Gullane and Pettycur lie on the Forth, and the geological horizon of the rocks at both localities is not very different, so that the similarity of the floras is not surprising.

The specimens from Gullane occur in a greyish-white clastic rock, which, on examination, proved to be a highly decomposed volcanic ash. It is suggested that the decomposition of the ash, by vapours emitted from the volcano during its activity, produced solutions of mineral matter which caused the petrification of plant-fragments included in the ash. These plant-fragments occur quite sporadically through the rock, and they have evidently not been drifted in water. The petrifying solutions have been both calcareous and siliceous, so that some specimens are preserved in carbonate of lime, others in silica, while a few are partly in the one and partly in the other.

The perfection of the preservation is very striking, and it is proposed to continue collecting specimens when possible. The Committee, therefore, desires reappointment.

*Photographs of Geological Interest.—Eighteenth Report of the Committee, consisting of Professors E. J. GARWOOD (Chairman), W. W. WATTS and S. H. REYNOLDS (Secretaries), Mr. G. BINGLEY, Dr. T. G. BONNEY, Messrs. C. V. CROOK and W. GRAY, Dr. R. KIDSTON, Mr. A. S. REID, Sir J. J. H. TEALL, and Messrs. R. WELCH and W. WHITAKER. (Drawn up by the Secretaries.)*

THE Committee have to report that since the issue of the last Report in 1910 they have received 429 photographs for the national collection. The total number in the collection is now 5,656, and the yearly average amounts to about 210.

Since the issue of the last Report the Committee have suffered the loss of Professor James Geikie, their Chairman for twenty-six years. They have also lost Dr. Tempest Anderson and Mr. H. B. Woodward, both of whom took great interest in the work of the Committee and made contributions to the collection.

The geographical scheme appended shows the distribution of new accessions among the counties. Kincardineshire figures in the list for the first time, and considerable additions have been made from Cornwall, Durham, Somerset, Surrey, and Inverness; while Yorkshire, with an addition of 127, has now over a thousand prints in the collection.

Mr. Bingley adds still further to his photographic survey of the Yorkshire coast, as well as sending sets from the Yorkshire Dales, from Settle, and from Leeds. He also contributes a carefully selected set from the Magnesian Limestone of the Durham coast. To him we owe prints from Cumberland, Westmorland, Lancashire, and the Isle of Man.

Professor Reynolds has illustrated the coasts of Cornwall and Devon, with the Carboniferous Limestone districts of Gloucester and Somerset. The igneous and ancient rocks of many parts of Scotland are also illustrated by him, particularly in Argyll, Forfar, Inverness, and Sutherland. He also contributes prints from Galway and Mayo.

Mr. A. S. Reid records the growth of deltas in certain Scottish Lochs; his photographs should be compared with Nos. 1867 and 1868.

Mr. R. Welch contributes very interesting series of prints taken with his usual skill and finish, from Derbyshire and from several Irish counties, including Clare and Limerick.

The late Mr. Russell Gwinnell sent numerous photographs taken in Skye and on the mainland; and Mr. Zealley took photographs to illustrate his work in the North of Ireland.

Photographs sent by Mr. Wickham King record his discovery of Downtonian rocks in the South Staffordshire Coalfield. Mr. L. Richardson sends prints in illustration of his Rhætic work. Colonel Haywood has photographed the coast scenery of the Isle of Man, and Mr. Cornwell-Walker presents, through Mr. Whitaker, a record of the excavations for a reservoir in Tunbridge Wells Sand, near Lingfield.

Counties	Previous Collection	Additions (1916)	Total
<b>ENGLAND—</b>			
Cornwall . . . . .	92	30	122
Cumberland . . . . .	44	1	45
Derbyshire . . . . .	65	4	69
Devonshire . . . . .	208	9	217
Dorset . . . . .	174	1	175
Durham . . . . .	145	65	210
Gloucestershire . . . . .	123	8	131
Hertfordshire . . . . .	22	2	24
Lancashire . . . . .	80	6	86
Oxfordshire . . . . .	1	3	4
Shropshire . . . . .	64	1	65
Somerset . . . . .	169	36	205
Surrey . . . . .	75	16	91
Sussex . . . . .	26	1	27
Westmorland . . . . .	87	6	93
Worcestershire . . . . .	27	2	29
Yorkshire . . . . .	960	127	1,087
Others . . . . .	922	—	922
Total . . . . .	3,284	318	3,602
<b>WALES—</b>			
Carnarvonshire . . . . .	118	8	126
Others . . . . .	286	—	286
Total . . . . .	404	8	412
<b>CHANNEL ISLANDS</b>			
	38	—	38
<b>ISLE OF MAN</b>			
	102	7	109
<b>SCOTLAND—</b>			
Argyllshire . . . . .	40	4	44
Fifeshire . . . . .	64	1	65
Forfarshire . . . . .	7	5	12
Inverness-shire . . . . .	177	25	202
Kincardineshire . . . . .	—	4	4
Perthshire . . . . .	24	8	32
Ross-shire . . . . .	19	2	21
Sutherlandshire . . . . .	48	9	57
Others . . . . .	224	—	224
Total . . . . .	603	58	661
<b>IRELAND—</b>			
Antrim . . . . .	237	11	298
Clare . . . . .	15	3	18
Cork . . . . .	23	2	25
Donegal . . . . .	54	2	56
Galway . . . . .	46	6	52
Limerick . . . . .	3	1	3
Londonderry . . . . .	26	2	28
Mayo . . . . .	25	11	36
Others . . . . .	220	—	220
Total . . . . .	698	38	736
<b>ROCK STRUCTURES, &amp;c.</b>			
	98	—	98
<b>SUMMARY.</b>			
ENGLAND . . . . .	3,284	318	3,602
WALES . . . . .	404	8	412
CHANNEL ISLANDS . . . . .	38	—	38
ISLE OF MAN . . . . .	102	7	109
SCOTLAND . . . . .	603	58	661
IRELAND . . . . .	698	38	736
ROCK STRUCTURES, &c. . . . .	98	—	98
Total . . . . .	5,227	429	5,656

Other contributors include Professor Allen, Mr. Montague Cooper, Mr. Cameron, Mr. Pritchett, Mr. A. E. Kitson, Mr. C. B. Storey, the late Mr. J. Parker, Dr. G. Abbott, Mr. Evers-Swindell, the Yorkshire Speleological Association, and Mr. E. Simpson. To all these helpers the Committee owe and beg to tender their thanks.

Prizes for photographs of scenery illustrating geological features have been offered by the Tunbridge Wells Natural History Society.

The Geological Survey has followed up the publication of a list of its own English geological photographs by one of its Scottish pictures, and made arrangements by which prints and slides may be purchased, thus giving to students and teachers an excellent opportunity of getting characteristic and typical geological illustrations.

In spite of this it is thought that there will still be scope for the issue of a new series by the Committee, as the ground covered by its collection is at present wider than that of the Geological Survey. Unfortunately, want of time has delayed the publication of the new series, but it is hoped that a method has now been found to bring about the long-promised publication.

Few additions to the duplicate series have been made since the issue of the published sets. Lectures on this series have been given by Mr. Whitaker at several local scientific societies, including the Ipswich and District Field Club, the Sidcup Literary and Scientific Society, the Folkestone Natural History Society, and the Sutton Society; as well as at other Societies and Institutions at Croydon and Sutton.

Applications by Local Societies for the loan of the duplicate collection of prints or slides should be made to the Secretary. A descriptive account of them can also be lent. The carriage and the making good of any damage to slides are the only expenses to be borne by the borrowing Society.

The Committee recommend that they be reappointed, and that Professor S. H. Reynolds be Secretary. A financial statement, given in the appendix, shows that the assets of the Committee amount to £169 8s. 10d.

## EIGHTEENTH LIST OF GEOLOGICAL PHOTOGRAPHS.

FROM AUGUST 23, 1910, TO AUGUST 31, 1916.

List of the geological photographs received and registered by the Secretaries of the Committee since the publication of the last Report.

Contributors are asked to affix the registered numbers, as given below, to their negatives for convenience of future reference. Their own numbers are added in order to enable them to do so.

*\* indicates that photographs and slides may be purchased from the donors or obtained through the address given with the series.*

Copies of other photographs desired can, in most instances, be obtained from the photographer direct, or from the officers of the Local Society under whose auspices the photograph was taken. The cost at which copies may be obtained depends on the size of the print and on local circumstances, over which the Committee have no control.

The Committee do not assume the copyright of any photographs

included in this list. Inquiries respecting photographs, and applications for permission to reproduce them, should be addressed to the photographers direct.

Copies of photographs should be sent *unmounted* to

Professor S. H. REYNOLDS,  
The University, Bristol,

accompanied by descriptions written on a form prepared for the purpose, copies of which may be obtained from him.

The size of photographs is indicated as follows:—

L = Lantern size.	1/1 = Whole Plate.
1/4 = Quarter-plate.	10/8 = 10 inches by 8.
1/2 = Half-plate.	12/10 = 12 inches by 10, &c.

E. signifies Enlargement.

## ACCESSIONS, 1910-1916.

### ENGLAND.

CORNWALL.—*Photographed by* GODFREY BINGLEY, *Thorniehurst, Headingley, Leeds.* 1/2.

Regd.  
No.

<b>5211</b>	(7468)	Land's End . . .	Granite Coast. 1906.
<b>5212</b>	(7469)	„ „ . . .	Weathered Granite. 1906.
<b>5213</b>	(7474)	„ „ . . .	Marine erosion of Granite (1906).

*Photographed by* Professor S. H. REYNOLDS, *M.A., Sc.D., The University, Bristol.* 1/4.

<b>5214</b>	(2·13)	Crousa Common . . .	Gabbro blocks. 1913.
<b>5215</b>	(3·13)	Coverack Cove . . .	Basic dyke cutting Gabbro, cutting Serpentine. 1913.
<b>5216</b>	(4·13)	„ „ . . .	Basic dyke cutting Gabbro, cutting Serpentine. 1913.
<b>5217</b>	(5·13)	„ „ . . .	Plexus of Gabbro veins in Serpentine. 1913.
<b>5218</b>	(6·13)	„ „ . . .	Plexus of Gabbro veins in Serpentine. 1913.
<b>5219</b>	(7·13)	„ „ . . .	Raised Beach and Head on Serpentine veined with Gabbro. 1913.
<b>5220</b>	(8·13)	„ „ . . .	Weathered surface of Serpentine. 1913.
<b>5221</b>	(9·13)	„ „ . . .	Two basic dykes in Serpentine. 1913.
<b>5222</b>	(11·13)	Spernic Cove, near Coverack.	Plexus of Gabbro veins in Serpentine. 1913.
<b>5223</b>	(12·13)	Carrick Luz, near Coverack.	Inclusion of Serpentine in Gabbro. 1913.
<b>5224</b>	(14·13)	Carrick Luz, near Coverack.	Augen Gabbro. 1913.
<b>5225</b>	(15·13)	Carrick Luz from W. . .	Marine erosion of Gabbro. 1913.
<b>5226</b>	(16·13)	Beagle's Pt., W. of Coverack.	Weathering of Serpentine. 1913.
<b>5227</b>	(17·13)	Chynall's Pt., Coverack	„ „ „
<b>5228</b>	(18·13)	„ „ „	„ „ „
<b>5229</b>	(21·13)	Compass Cove, Lizard . . .	Gabbro cutting „ Serpentine cut by Epidiorite dykes. 1913.
<b>5230</b>	(23·13)	Poldourian, Lizard . . .	Banded Chromite Serpentine. 1913.
<b>5231</b>	(25·13)	Kennack Cove, Lizard . . .	Epidiorite dykes in Serpentine. 1913.
<b>5232</b>	(38·13)	Gunwalloe, near Helston	Contorted Manaccan beds (Devonian). 1913.

Regd.

No.

- 5233** (44·13) Porthleven . . . . The Giant's rock, an enormous Erratic of Granitic Gneiss. 1913.
- 5234** (44a·13) Loe Bar, near Helston The Sand bar holds up the water of the Helston river. 1913.
- 5235** (45·13) Porthleven Cliffs . . Sea Cave and Shore Platform, with large Erratic, the 'Giant's Rock.' 1913.
- 5236** (46·13) Lavarnick Pit, Kynance Rock fall probably due to under-cutting of the Serpentine. 1913.
- 5237** (49·13) Gew Graze, Kynance . Rock fall presumably due to under-cutting of the Serpentine. 1913.
- 5238** (50·13) Parc Bean, Kynance . Epidiorite dykes cutting Serpentine. 1913.
- 5239** (51·13) Mullion Island and Kynance Rocks. 1913.
- 5240** (52·13) Pentreath Beach, Lizard Veined Serpentine. 1913.

CUMBERLAND.—*Photographed by* GODFREY BINGLEY, *Thorniehurst, Headingley, Leeds.* 1/4.

(9114) Wasdale . . . . Screes. 1910.

DERBYSHIRE.—*Photographed by* R. WELCH,\* 49 *Lonsdale Street, Belfast.* 1/1.

- 5226** (4109) Miller's Dale . . . . Toadstone and Carboniferous Limestone. 1904.
- 5227** (4114) Blue John Mine, Castle-ton. Swallow Hole. 1905.
- 5228** (4111) Castleton . . . . Mouth of Windy Knoll Cave. 1905.
- 5229** (4112) Bradwell Dale . . . . Encrinite band in Carboniferous Limestone. 1905.

DEVONSHIRE.—*Photographed by* Professor S. H. REYNOLDS, M.A., *Sc.D., The University, Bristol.* 1/4.

- 5242** (1·10) Beer Head, from East . Chalk Cliffs, Upper Greensand in foreground. 1910.
- 5243** (2·10) Whitecliff and Seaton . Upper Cretaceous section. 1910. Upper Greensand to zone of *T. gracilis*.
- 5244** (4·10) Beer Harbour, north side Chalk section, from *R. Cuvieri* to *M. cor-testudinarium* zone. 1910.
- 5245** (5·10) Beer, Annie's Knob . Outcrop of *M. cor-testudinarium* zone. 1910.
- 5246** (6·10) West of Hooken Cliff, Beer. Upper Greensand at base of cliff. 1910.
- 5247** (8·10) Hooken and Under Slipped Upper Cretaceous Rocks. Hooken, Beer. 1910.
- 5248** (10·10) West of Lyme Regis . Small Slips. 1910.

*Photographed by* F. J. ALLEN, M.A., D.Sc., 8 *Halifax Road, Cambridge.* 1/4.

- 5249** ( ) Westleigh Quarry, near Burlescombe. Contorted Carboniferous Limestone. 1912.

*Photographed by* MONTAGUE COOPER,\* *Photographer, Taunton.* 12/10.

- 5250** ( ) Westleigh Quarry, near Burlescombe. Contorted Carboniferous Limestone. 1912.

DORSETSHIRE.—Presented by A. C. G. CAMERON, *Harcombe Bank, Uplyme.* 6/3.

Regd.  
No.

5251 ( ) Lyme Regis . . . Burning cliffs of Lias.

DURHAM.—Photographed by GODFREY BINGLEY, *Thorniehurst, Headingley, Leeds.* 1/2.

- |      |        |   |   |
|------|--------|---|---|
| 5252 | (9266) | Trow Rocks, S. Shields                        | Brecciated Magnesian Limestone thrust over well-bedded ditto. 1910.                   |
| 5253 | (9267) | „ „   | Thrust plane in disturbed Magnesian Limestone. 1910.                                  |
| 5254 | (9268) | „ „   | Mylonised band at thrust plane in Magnesian Limestone. 1910.                          |
| 5255 | (9269) | Frenchman's Bay, S. Shields.                  | Fissuring and thrust faulting in Magnesian Limestone. 1910.                           |
| 5256 | (9271) | Frenchman's Bay, S. Shields.                  | Magnesian Limestone thrust over well-bedded strata. 1910.                             |
| 5257 | (9272) | Frenchman's Bay, S. Shields.                  | Cellular Magnesian Limestone. 1910.   |
| 5258 | (9273) | Marsden Bay, Sunderland                       | Velvet beds, top of brecciated beds, Magnesian Limestone. 1910.                       |
| 5259 | (9274) | „ „   | Mass of Breccia filling fissure. 1910.  |
| 5260 | (9275) | „ „   | Twisted 'cleavage' in Upper Magnesian Limestone. 1910.                                |
| 5261 | (9276) | „ „   | Jointing in Upper Magnesian Limestone. 1910.  |
| 5262 | (9277) | Cliffs, Marsden Bay, Sunderland.              | Folding, buckling, &c., of Magnesian Limestone against horst (outside picture). 1910. |
| 5263 | (9278) | S. of Grotto, Marsden Bay, Sunderland.        | Jointing passing into brecciation of Magnesian Limestone. 1910.                       |
| 5264 | (9279) | Cliffs S. of Grotto, Marsden Bay, Sunderland. | Minute brecciation of Magnesian Limestone. 1910.                                      |
| 5265 | (9280) | S. of Grotto, Marsden Bay, Sunderland.        | Brecciation and contortion in Magnesian Limestone. 1910.                              |
| 5266 | (9282) | Marsden Quarry, Sunderland.                   | Block of stellate concretionary Magnesian Limestone. 1910.                            |
| 5267 | (9234) | Marsden Bay, Sunderland                       | Stack of Magnesian Limestone, concretionary and brecciated. 1910.                     |
| 5268 | (9236) | „ „   | Cliffs and stacks of Magnesian Limestone. 1910.                                       |
| 5269 | (9237) | „ „   | Sea stacks of Magnesian Limestone. 1910.  |
| 5270 | (9238) | Marsden Rock, Marsden Bay.                    | Marine erosion of Magnesian Limestone. 1910.  |
| 5271 | (9240) | Marsden Bay, Sunderland                       | Fissures in Magnesian Limestone Breccia. 1910.  |
| 5272 | (9241) | „ „   | Brecciated Magnesian Limestone. 1910.   |
| 5273 | (9242) | „ „   | Bedded and partly brecciated Upper Magnesian Limestone. 1910.                         |
| 5274 | (9243) | „ „   | Vertical 'Breccia-gash' standing out from cliff. 1910.                                |
| 5275 | (9244) | „ „   | Stack of Magnesian Limestone Breccia. 1910.   |
|      |        | 'The Chimney Rock.'                           |   |
| 5276 | (9247) | Marsden Bay, Sunderland                       | Sea cave. 1910.   |
| 5277 | (9248) | „ „   | Sea stacks of Magnesian Limestone Breccia. 1910.                                      |
| 5278 | (9231) | Between Sunderland and Marsden Bay.           | Sea stack of Permian Breccias. 1910.  |

Regd. No.		
<b>5279</b>	(9232) S. of Marsden Bay	Marine erosion of Permian Breccias. 1910.
<b>5280</b>	(9233) Coast near Lizard Point between Sunderland and Marsden Bay.	Sea stacks and cliffs of Permian Breccia. 1910.
<b>5281</b>	(9225) 'Holey-rock,' Roker, near Sunderland.	Sea caves in Magnesian Limestone. 1910.
<b>5282</b>	(9226) Roker, near Sunderland	'Cannon-ball' Magnesian Limestone. 1910.
<b>5283</b>	(9227) ,, ,,	'Cannon-ball' Magnesian Limestone. 1910.
<b>5284</b>	(9228) ,, ,,	'Cannon-ball' Magnesian Limestone. 1910.
<b>5285</b>	(9283) Fulwell Quarry, Sunderland.	Cellular concretionary Magnesian Limestone. 1910.
<b>5286</b>	(9284) Fulwell Quarry, Sunderland.	Honeycomb concretionary Magnesian Limestone. 1910.
<b>5287</b>	(9285) Fulwell Quarry, Sunderland.	Botryoidal Magnesian Limestone. 1910.
<b>5288</b>	(9286) Fulwell Quarry, Sunderland.	Cellular concretionary Magnesian Limestone. 1910.
<b>5289</b>	(9287) Fulwell Quarry, Sunderland.	Concretionary Magnesian Limestone. 1910.
<b>5290</b>	(9288) Fulwell Quarry, Sunderland.	Concretionary Magnesian Limestone. 1910.
<b>5291</b>	(9289) West Boldon, near Sunderland.	Breccia and Lower Magnesian Limestone. 1910.
<b>5292</b>	(9290) West Boldon, near Sunderland.	Breccia and Lower Magnesian Limestone. 1910.
<b>5293</b>	(9291) Down Hill Quarry, Boldon, near Sunderland.	Disturbed mass of Magnesian Limestone. 1910.
<b>5294</b>	(9292) Down Hill Quarry, Boldon, near Sunderland.	Fissuring in Lower Magnesian Limestone. 1910.
<b>5295</b>	(9293) Down Hill Quarry, Boldon, near Sunderland.	Sequence 'Yellow Sands' to Fossiliferous Limestone. 1910.
<b>5296</b>	(9294) Down Hill Sand Pit, Boldon, near Sunderland.	False-bedding and bands of MnO <sub>2</sub> in Permian Sands. 1910.
<b>5297</b>	(9305) Fulwell Quarry, near Sunderland.	Botryoidal Magnesian Limestone. 1910.
<b>5298</b>	(9306) Fulwell Quarry, near Sunderland.	Honeycomb concretionary Magnesian Limestone. 1910.
<b>5299</b>	(9295) Near Hylton Castle, Sunderland.	Disturbed Lower Magnesian Limestone. 1910.
<b>5300</b>	(9296) Near Hylton Castle, Sunderland.	Disturbed Lower Magnesian Limestone. 1910.
<b>5301</b>	(9249) Hendon, near Sunderland	Concretionary, Upper Magnesian Limestone. 1910.
<b>5302</b>	(9250) Cliffs at Hendon, S. of Sunderland.	Concretionary Magnesian Limestone, capped by Boulder Clay. 1910.
<b>5303</b>	(9251) Cliffs at Hendon, S. of Sunderland.	Honeycomb concretionary, Upper Magnesian Limestone. 1910.
<b>5304</b>	(9252) Hendon, near Sunderland	Bedding planes passing through Magnesian Limestone Concretions. 1910.
<b>5305</b>	(9253) Cliffs, Hendon, S. of Sunderland.	Middle Permian thrust over Upper Concretionary Beds. 1910.
<b>5306</b>	(9254) Cliffs, Hendon, near Sunderland.	Block-fractured rock and phacoidal structure developed above Thrust plane. 1910.
<b>5307</b>	(9255) 'Jane Jewison's Rock,' between Sunderland and Ryhope.	Slickensided Breccia. 1910.



- Regd.  
No.
- 5308** (9256) 'Jane Jewison's Rock,' Slickensided surface. 1910.  
between Sunderland and Ryhope.
- 5309** (9257) Cliffs near Ryhope, S. of Breccia resting on well-bedded Permian rocks. 1910.  
Sunderland.
- 5310** (9258) Marslack, near Ryhope, Breccia thrust over disturbed Magnesian Limestone. 1910.  
S. of Sunderland.
- 5311** (9259) Marslack, near Ryhope, Strata disturbed by small Thrust. 1910.  
S. of Sunderland.
- 5312** (9260) Grindon, near Sunderland Esker. 1910.
- 5313** (9261) Grindon, near Sunderland Gravel and sands of Esker. 1910.
- 5314** (9263) Claxheugh, by R. Wear, Rock-fall and section of Permian Beds. 1910.  
2 miles W. of Sunderland.
- 5315** (9264) Claxheugh, by R. Wear, False-bedded Yellow Permian Sandstone. 1910.  
2 miles W. of Sunderland.
- 5316** (9265) Near Claxheugh, Sunderland. Minutely faulted cellular Breccia. 1910.

GLOUCESTERSHIRE.—*Photographed by Professor S. H. REYNOLDS, M.A., Sc.D., The University, Bristol. 1/2.*

- 5317** (1-12) Sodbury Section (Carboniferous Limestone). Upper D Beds. 1912.
- 5318** (2-12) Sodbury Section (Carboniferous Limestone). Lower D and Upper S<sub>2</sub> Beds. 1912.
- 5319** (3-12) Sodbury Section (Carboniferous Limestone). The Base of the Concretionary Beds and *Seminula-Oolite*. 1912.
- 5320** (4-12) Sodbury Section (Carboniferous Limestone). Base of S<sub>2</sub> and S<sub>1</sub> Beds. 1912.
- 5321** (5-12) Sodbury Section (Carboniferous Limestone). S<sub>1</sub> and top of C<sub>2</sub>. 1912.
- 5322** (6-12) Sodbury Section (Carboniferous Limestone). *Caninia-Dolomites* and Swallet. 1912.
- 5323** (7-12) Sodbury Section (Carboniferous Limestone). *Laminosa-Dolomites*, &c. (C<sub>1</sub>). 1912.
- 5324** (8-12) Sodbury Section (Carboniferous Limestone). Z Beds. 1912.

HERTFORDSHIRE.—*Photographed by G. E. PRITCHETT, F.S.A., Oak Hall, Bishop's Stortford. 1/1.*

- 5325** ( ) Whitehall Farm, Bishop's Hertfordshire Puddingstone, 22 tons  
Stortford. estimated.
- 5326** ( ) Whitehall Farm, Bishop's Hertfordshire Puddingstone, 5 tons  
Stortford. estimated.

LANCASHIRE.—*Photographed by GODFREY BINGLEY, Thorniehurst, Headingley, Leeds. 1/2.*

- 5327** (7723) Hook Clough, Pendle Hill *Callograptus carboniferus*. 1906.
- 5328** (8455) Leck Beck . . . Current-bedded Carboniferous Sands and Shales. 1909.
- 5329** (8466) Sellet, near Kirkby Lonsdale. Limestone quarry. 1909.
- 5330** (8467) Sellet, near Kirkby Lonsdale. Quarry in Yoredale Sandstone. 1909.
- 5331** (8470) Whittington Quarry . Whittington Limestone, Yoredale Series. 1909.
- 5332** (8471) Penford Beck, near Whittington. Shales above Whittington Limestone, Yoredale Series. 1909.

OXFORDSHIRE.—*Photographed by A. E. KITSON, F.G.S., 109 Worple Road, Wimbledon, S.W. 1/4.*

Regd.  
No.

<b>5333</b>	( )	Blackthorn Hill, Bicester	Great Oolite and Cornbrash.	1908.
<b>5334</b>	( )	" "	" "	" "
<b>5335</b>	( )	" "	" "	" "

SHROPSHIRE—*Photographed by C. B. STOREY, M.A., F.G.S., Plas Nantyr, Glyn, Ruabon. 1/4.*

**5336** ( ) The 'Devil's Chair,' the Arenig Quartzite. 1902.  
Stiperstones.

SOMERSET.—*Photographed by Professor S. H. REYNOLDS, M.A., Sc.D., The University, Bristol. 1/2 and 1/4.*

<b>5337</b>	(07·59)	Burrington Combe	Silicified <i>Lithostrotion</i> in S <sub>2</sub> Beds.	1907.
<b>5338</b>	(07·60)	" "	'The Cave.'	1907.
<b>5339</b>	(07·61)	" "	Entrance to the Goatchurch Cave.	1907.
<b>5340</b>	(09·37)	" "	Quarry 1 (base of D <sub>1</sub> , top of S <sub>2</sub> ).	1909.
<b>5341</b>	(09·39)	" "	Quarry 1 and S <sub>2</sub> Beds.	1909.
<b>5342</b>	(09·40)	" "	Quarry 2, and hillside to the N.	1909.
<b>5343</b>	(09·41)	" "	Hillside between Quarries 1 and 2, and part of Quarry 2.	1909.
<b>5344</b>	(09·42)	" "	Quarry 2 (S <sub>1</sub> , and the lower part of S <sub>2</sub> ).	1909.
<b>5345</b>	(09·43)	" "	The section between Quarry 2 and 'The Cave.'	1909.
<b>5346</b>	(09·45)	" "	Quarry 3 and the C <sub>2</sub> scarp.	1909.
<b>5347</b>	(09·46)	" "	S <sub>1</sub> and C Beds from Quarry 2 to near Quarry 3.	1909.
<b>5348</b>	(09·47)	" "	S <sub>1</sub> and C <sub>2</sub> Beds.	1909.
<b>5349</b>	(09·50)	" "	Base of C <sub>2</sub> Dolomites of Quarry 3, and top of C <sub>1</sub> γ.	1909.
<b>5350</b>	(09·51)	" "	C <sub>1</sub> γ Beds.	1909.
<b>5351</b>	(09·52)	" "	Hillside between C <sub>2</sub> scarp and C <sub>1</sub> γ scarp.	1909.
<b>5352</b>	(09·54)	" "	Quarry 3 and scarps of C <sub>2</sub> and C <sub>1</sub> γ.	1909.
<b>5353</b>	(09·55)	" "	The Great Scarp of C <sub>1</sub> γ.	1909.
<b>5354</b>	(09·56)	" "	Great Scarp of C <sub>1</sub> γ from W.	1909.
<b>5355</b>	(09·57)	" "	Valley of W. twin Stream and Great Scarp of C <sub>1</sub> γ beyond it.	1909.
<b>5356</b>	(09·58)	" "	Upper part of Combe and side of valley of Eastern twin Stream.	1909.
<b>5357</b>	(09·61)	" "	The Eastern twin Stream.	1909.
<b>5358</b>	(09·63)	" "	Valley of the Western twin Stream.	1909.
<b>5359</b>	(09·65)	" "	Weathered surface of coarse Crinoidal Oolite, E. twin Stream.	1909.
<b>5360</b>	(11·1)	Vobster Old Quarry, general view, looking westward.	Overfolded S <sub>2</sub> and D <sub>1</sub> Beds.	1911.
<b>5361</b>	(11·2)	Vobster Quarry, eastern part of northern face.	Overfolded S. Beds planed down and capped by Lias.	1911.
<b>5362</b>	(11·3)	Vobster Quarry, western end.	Highest <i>Seminula</i> -Beds, overfolded.	1911.

Regd. No.			
<b>5363</b>	(11·4)	Vobster Quarry . .	Lias on planed down and overfolded Carboniferous Limestone. 1911.
<b>5364</b>	(11·5)	„ „ . .	Lias on planed down and overfolded Carboniferous Limestone. 1911.
<b>5365</b>	(11·6)	„ „ . .	Lias on planed down and overfolded Carboniferous Limestone. 1911.

*Photographed by the late JAMES PARKER, 21 Turl Street, Oxford.*

<b>5366</b>	( )	Vobster Quarry . .	Lias resting against Carboniferous Limestone. 1909.
-------------	-----	--------------------	---

*Photographed by L. RICHARDSON, 10 Oxford Parade, Cheltenham.  
1/2, 5/4, and 1/4.*

<b>5367</b>	(1)	Warren Farm section, near Watchet.	Disturbed Keuper Marls. 1904.
<b>5368</b>	(2)	Cleeve Bay, looking towards N. Hill, Minehead.	Coast scenery near Blue Anchor Point and Warren Farm section. 1904.
<b>5369</b>	(3)	Foreshore section, near Blue Anchor Point, Watchet.	Sully Beds and Rhætic Beds. 1904.
<b>5370</b>	(4)	Blue Anchor Point, Watchet	Anticlinal arrangement of Keuper and Rhætic Beds. 1904.
<b>5371</b>	(5)	Top of cliff, Blue Anchor Point, Watchet.	Rhætic (Cotham, Langport, and Watchet Beds) and Base of Lias. 1904.
<b>5372</b>	(6)	Blue Anchor Point, Watchet	Keuper Marls, with veins of Gypsum. 1904.

*SURREY.—Photographed by A. E. CORNEWALL-WALKER, Redhill, Surrey. 1/2.*

<b>5373</b>	( )	Dry Hill, near Lingfield. Reservoir for East Surrey Waterworks, looking north.	Tunbridge Wells Sand. 1912.
<b>5374</b>	( )	Dry Hill, near Lingfield. Reservoir for East Surrey Waterworks, looking north.	„ „ „ „
<b>5375</b>	( )	Dry Hill, near Lingfield. Reservoir for East Surrey Waterworks, looking north.	„ „ „ „
<b>5376</b>	( )	Dry Hill, near Lingfield. Reservoir for East Surrey Waterworks, looking north.	„ „ „ „
<b>5377</b>	( )	Dry Hill, near Lingfield. Reservoir for East Surrey Waterworks, looking north.	„ „ „ „
<b>5378</b>	( )	Dry Hill, near Lingfield. Reservoir for East Surrey Waterworks, looking south.	„ „ „ „
<b>5379</b>	( )	Dry Hill, near Lingfield. Reservoir for East Surrey Waterworks, looking south.	„ „ „ „
<b>5380</b>	( )	Dry Hill, near Lingfield. Reservoir for East Surrey Waterworks, looking south.	„ „ „ „
<b>5381</b>	( )	Dry Hill, near Lingfield. Reservoir for East Surrey Waterworks, looking south.	„ „ „ „
<b>5382</b>	( )	Dry Hill, near Lingfield. Reservoir for East Surrey Waterworks, looking south.	„ „ „ „

Regd.

No.

<b>5383</b>	( )	Dry Hill, near Lingfield. Reservoir for East Surrey Waterworks, looking west.	Tunbridge Wells Sand.	1912.
<b>5384</b>	( )	Dry Hill, near Lingfield. Reservoir for East Surrey Waterworks, looking west.	" " "	" "
<b>5385</b>	( )	Dry Hill, near Lingfield. Reservoir for East Surrey Waterworks, looking west.	" " "	" "
<b>5386</b>	( )	Dry Hill, near Lingfield. Reservoir for East Surrey Waterworks, looking east.	" " "	" "
<b>5387</b>	( )	Dry Hill, near Lingfield. Reservoir for East Surrey Waterworks, looking east.	" " "	" "
<b>5388</b>	( )	Dry Hill, near Lingfield. Reservoir for East Surrey Waterworks, looking east.	" " "	" "

SUSSEX.—*Photographed by* JOHNSON, BIRD, AND CO.,\* 20 High Street, Tunbridge Wells, and presented by Dr. G. ABBOTT. L.

<b>5389</b>	( )	Eridge Rocks, nr. Tun- bridge Wells.	False-bedding in Tunbridge Wells Sand.	1909.
-------------	-----	---	---	-------

WESTMORLAND.—*Photographed by* GODFREY BINGLEY, Thorniehurst, Headingley, Leeds. 1/2.

<b>5390</b>	(8445)	Brigsteer . . .	Carboniferous Limestone Escarpment.	1909.
<b>5391</b>	(8448)	Barbon Beck, Barbon .	Carboniferous Limestone in bed of stream.	1909.
<b>5392</b>	(8449)	" "	Junction of Carboniferous Limestone and Red Conglomerate.	1909.
<b>5393</b>	(8456)	R. Lune, Kirkby Lons- dale.	Red Conglomerate.	1909.
<b>5394</b>	(8472)	Hutton Roof Quarry .	Section in Yoredale Grits.	1909.
<b>5395</b>	(8474)	" " "	" " "	" "

WORCESTERSHIRE.—*Photographed by* H. S. EVERS-SWINDELL, Pedmore; and sent by W. WICKHAM KING, F.G.S., Stourbridge. 1/2.

<b>5396</b>	(L)	Hayes, near Halesowen .	Coal Measures resting unconformably on Ludlow and Downton Beds.	1912.
<b>5397</b>	(R)	" "	Coal Measures resting unconformably on Ludlow and Downton Beds.	1912.

YORKSHIRE.—*Photographed by* GODFREY BINGLEY, Thorniehurst, Headingley, Leeds. 1/2 and 1/4.

<b>5398</b>	(9207)	Roseberry Topping .	Cutting in Shales and Ironstone.	1910.
<b>5399</b>	(9211)	" "	Outlier.	1910.
<b>5400</b>	(9215)	Ayton . . .	Whin Sill as seen in quarry face.	1910.
<b>5401</b>	(9216)	" . . .	Quarry in Whin Sill.	1910.
<b>5402</b>	(9715)	Blea Hill Rigg . . .	End of Cleveland Dyke.	1912.
<b>5403</b>	(9716)	Foul Syke, Fylingdale Moors.	Peat cutting, with tree stumps.	1912.

Regd. No.		
<b>5404</b>	(9708) Yellow Sand Bight, near Whitby.	Roots from Lower Estuarine Series, penetrating Dogger and Upper Lias. 1912.
<b>5405</b>	(9709) Yellow Sand Bight, between Whitby and Saltwick Nab.	Fossil root in Upper Lias overlain by Dogger. 1912.
<b>5406</b>	(9710) Yellow Sand Bight, between Whitby and Saltwick Nab.	Hollow in Dogger due to decay of tree trunks. 1912.
<b>5407</b>	(9720) Near Robin Hood's Bay	Landslip on Cliffs. 1912.
<b>5408</b>	(9702) Robin Hood's Bay	Tan-pits beck fall. 1912.
<b>5409</b>	(9693) The Peak, near Whitby	Dogger and Estuarine Sandstone, S. side of Peak Fault. 1912.
<b>5410</b>	(9700) " " "	Bosses in Alum Shale on shore. 1912.
<b>5411</b>	(8525) Hayburn Wyke	Cliffs and Waterfall. 1909.
<b>5412</b>	(8562) Iron Scar, S. of Hayburn Wyke.	Ellerbeck Beds, Lower Estuarine Series. 1909.
<b>5413</b>	(8563) Iron Scar, near Hayburn Wyke.	Ripple-marked Ellerbeck Beds. 1909.
<b>5414</b>	(8564) Iron Scar, S. of Hayburn Wyke.	Ellerbeck Beds, Lower Estuarine Series. 1909.
<b>5415</b>	(8566) Iron Scar, S. of Hayburn Wyke.	Ellerbeck Beds, Lower Estuarine Series. 1909.
<b>5416</b>	(8552) Cloughton Wyke	Estuarine Series, Lower Oolite. 1909.
<b>5417</b>	(8553) " "	Estuarine Series. 1909.
<b>5418</b>	(8557) " "	Estuarine Series, Lower Oolite. 1909.
<b>5419</b>	(8558) " "	Ripple marked Middle Estuarine Sandstone. 1909.
<b>5420</b>	(8559) " "	Block of current-bedded Middle Estuarine Sandstone. 1909.
<b>5421</b>	(8547) Hundale Point, Cloughton Wyke.	Estuarine Sandstone, with ripple marks and worm tracks. 1909.
<b>5422</b>	(9317) Burmston Bay, N. of Scarborough.	Upper Estuarine Sandstone, with <i>Unio distorta</i> . 1911.
<b>5423</b>	(9319) Cromer Point, near Scarborough.	Current-bedding in Boulder of Upper Estuarine Sandstone. 1911.
<b>5424</b>	(6940) Scalby Bay, N. of Scarborough.	Estuarine Beds. 1905.
<b>5425</b>	(6941) Scalby Bay, near Scarborough.	" " "
<b>5426</b>	(6942) Scalby Bay, near Scarborough.	Boulder Clay, sands and gravel. 1905.
<b>5427</b>	(6943) Scalby Bay, near Scarborough.	Boulder Clay section. 1905.
<b>5428</b>	(6944) Scalby Bay, near Scarborough.	" " " "
<b>5429</b>	(6945) Scalby Bay, near Scarborough.	Boulder Clay, gravels and silt. 1905.
<b>5430</b>	(6947) Scalby Bay, near Scarborough.	Boulder Clay, sand and gravel. 1905.
<b>5431</b>	(6948) Scalby Bay, near Scarborough.	Pockets of gravel in Boulder Clay. 1905.
<b>5432</b>	(6949) Scalby Bay, near Scarborough.	Pockets of gravel in Boulder Clay. 1905.
<b>5433</b>	(6950) Scalby Bay, near Scarborough.	Pockets of gravel in Boulder Clay. 1905.
<b>5434</b>	(6951) Scalby Bay, near Scarborough.	Pockets of gravel in Boulder Clay. 1905.
<b>5435</b>	(6952) Scalby Bay, near Scarborough.	Boulder Clay, sands, &c. 1905.
<b>5436</b>	(6953) Scalby Bay, near Scarborough.	Gravels in Boulder Clay. 1905.

Regd. No.			
5437	(6954) Scalby Bay, near Scarborough.	Base of Boulder Clay Cliff.	1905.
5438	(6955) Scalby Ness, near Scarborough.		1905.
5439	(6957) Cliffs S. of Holbeck Gardens, Scarborough.	Strongly jointed Upper Estuarine Series.	1905.
5440	(6938) Carnelian Bay, Scarborough.	Boulder Clay on Lower Estuarine Series.	1905.
5441	(9310) Carnelian Bay, Scarborough.	Bedding of Upper Estuarine Sandstone.	1911.
5442	(9314) Carnelian Bay, Scarborough.	Landslip in cliff.	1911.
5443	(6929) Osgodby Nab, S. of Scarborough.	Estuarine Series capped by Boulder Clay.	1905.
5444	(6931) Osgodby Nab, S. of Scarborough.	Estuarine and Millepore Series capped by Boulder Clay.	1905.
5445	(6932) Osgodby Nab, S. of Scarborough.	Estuarine and Millepore beds.	1905.
5446	(6934) Osgodby Nab, S. of Scarborough.	" " " "	
5447	(6935) Osgodby Nab, S. of Scarborough.	" " " "	
5448	(6936) Osgodby Nab, S. of Scarborough, from Carnelian Bay	" " " "	
5449	(6926) Cayton Bay, S. of Scarborough.	Shingle spit and sand dunes.	1905.
5450	(6965) Red Cliff, Cayton Bay, S. of Scarborough.	Middle Oolite succession, cornbrash to Lower Calcareous Grit.	1905.
5451	(6967) Red Cliff, Cayton Bay, S. of Scarborough.	Lower Calcareous Grit, Oxford Clay, Kellaway Rock.	1905.
5452	(6969) Red Cliff, Cayton Bay, S. of Scarborough.	Kellaway Rock at base of cliff.	1905.
5453	(6966) End of Yons Nab, S. of Cayton Bay, Scarborough.	Estuarine Series.	1905.
5454	(8834) Beach near Reighton, S. of Filey.	Kimmeridge Clay, with nodules containing <i>Perisphinctes</i> .	1910.
5455	(8835) Speeton Gap, near Filey	Slipped Red Chalk.	1910.
5456	(8837) Speeton Cliffs, Flamborough Head.	Red Chalk.	1910.
5457	(7357) Speeton . . . .	Ammonites.	1906
5458	(7358) " . . . .	" "	
5459	(7359) " . . . .	" "	
5460	(7364) " . . . .	" "	
5461	(7360) " . . . .	" "	
5462	(7365) " . . . .	" "	
5463	(7361) " . . . .	" "	
5464	(7366) " . . . .	" "	
5465	(7362) " . . . .	" "	
5466	(7363) " . . . .	" "	
5467	(8845) Cliffs between S. Landing and High Stacks, Flamborough.	Chalk.	1910.
5468	(8847) Flamborough Head, N. side of S. Sea Landing.	Chalk capped by Boulder Clay.	1910.
5469	(8849) South Sea Landing, Flamborough.	Chalk Cliffs.	1910.
5470	(8851) High Stacks, Flamborough.	Marine Erosion of Chalk.	1910.
5471	(8852) N. of High Stacks, Flamborough.	Chalk Cliffs and Sea Caves.	1910.
5472	(8853) High Stacks, Flamborough.	Arch in Chalk.	1910.

Regd.

No

- 5473** (8855) Selwick Bay, Flamborough . Erosion of Chalk Cliffs. 1910.  
**5474** (8857) Flamborough Head . . . Marine Erosion of Chalk. 1910.  
**5475** (8858) " " " . . . Chalk Cliffs. 1910.  
**5476** (8869) Thornwick Bay, Flam- Arch in Chalk Cliff. 1910.  
 borough Head.  
**5477** (8846) Near Danes Dyke, Flam- Chalk Cliffs. 1910.  
 borough.  
**5478** (8843) Sewerby, near Bridlington . Boulder Clay against Pre-glacial  
 Chalk Cliff. 1910.  
**5479** (8844) Flamborough Head from Chalk and Boulder Clay. 1910.  
 Sewerby.  
**5480** (8477) Gannister Quarry, Meanwood Folded Gannister. 1909.  
 Valley, near Leeds.  
**5481** (8497) Gannister Quarry, Meanwood Disturbed Gannister. 1909.  
 Valley, near Leeds.  
**5482** (8498) Gannister Quarry, Meanwood Crushed Gannister. 1909.  
 Valley, near Leeds.  
**5483** (8797) Gannister Quarry, Meanwood Overthrust. 1909.  
 Valley, near Leeds.  
**5484** (8798) Gannister Quarry, Meanwood Coal seam. 1909.  
 Valley, near Leeds.  
**5485** (8908) Semmer Water, near Bain- 1910.  
 bridge.  
**5486** (8909) Semmer Water, near Bain- 1910.  
 bridge.  
**5487** (8912) River Bain, Wensleydale, 1910.  
 emerging from Semmer Water.  
**5488** (8913) River Bain, Wensleydale . Looking down stream from spot  
 whence No. 5487 was taken.  
 1910.  
**5489** (8926) Parker Gill Force . . . Yoredale Limestone undercut.  
 1910.  
**5490** (8929) Mill Gill, near Askrigg . Black Shales overlying Great Sea  
 Limestone. 1910.  
**5491** (8942) " " " . Yoredale Series. 1910.  
**5492** (8943) Whitfield Force, near Ask- The fall is over Yoredale Black  
 rigg. Shales. 1910.  
**5493** (8946) Cogill Beck, near Askrigg . Stream-bed showing jointing in  
 Yoredale Limestone. 1910.  
**5494** (8947) " " " . Stream-bed showing jointing in  
 Yoredale Limestone. 1910.  
**5495** (8948) " " " . Jointing and pitting in Yoredale  
 Limestone. 1910.  
**5496** (8804) Attermine Scars, Settle . Cliffs of Carboniferous Limestone.  
 1910.  
**5497** (8822) Attermine Scars, Settle . Scree of Carboniferous Limestone.  
 1910.  
**5498** (8819) Attermine and Langcliff Bare Scars of Carboniferous Lime-  
 Scars, near Settle. stone. 1910.  
**5499** (8807) Langcliffe Scar, near Settle, 1910.  
 with entrance to Victoria Cave.  
**5500** (9670) Entrance to Victoria Cave, 1912.  
 Settle.  
**5501** (8818) Warrendale Knotts, Atter- Scars of Carboniferous Limestone.  
 mine Scars, Settle. 1910.  
**5502** (8820) Warrendale Knotts, Atter- Carboniferous Limestone Scars.  
 mine Scars, Settle. 1910.  
**5503** (8806) Warrendale Knotts, Atter- Bare Scars of Carboniferous Lime-  
 mine Scars, Settle. stone. 1910.  
**5504** (9675) Black Hill, near Settle . Silurian below Millstone Grit. 1912.

Regd.

No.

<b>5505</b>	(9676)	Black Hill, near Settle	. Silurian below Millstone Grit. 1912.
<b>5506</b>	(9678)	Cowside Beck, near Settle	. Basement Conglomerate of Carboniferous Age. 1912.
<b>5507</b>	(9679)	„ „ „	. Basement Conglomerate of Carboniferous Age. 1912.
<b>5508</b>	(9366)	„ „ „	. Basement Conglomerate of Carboniferous Age. 1912.
<b>5509</b>	(9368)	„ „ „	. Basement Conglomerate of Carboniferous Age. 1912.
<b>5510</b>	(9370)	„ „ „	. Basement Conglomerate of Carboniferous Age. 1912.
<b>5511</b>	(9371)	„ „ „	. Basement Conglomerate of Carboniferous Age. 1912.
<b>5512</b>	(9372)	„ „ „	. Carboniferous Limestone and Rubble Beds. 1911.
<b>5513</b>	(9364)	Mealsbank Quarry, Ingleton	Carboniferous Limestone. 1911.
<b>5514</b>	(9365)	„ „ „	„ „ „
<b>5515</b>	(8810)	Kingsdale, near Ingleton	. Carboniferous Limestone Erratic. 1910.
<b>5516</b>	(8813)	Routen Pot, Kingsdale	. 1910.
<b>5517</b>	(9362)	Right bank of Greta, Ingleton.	Exposure of Coal Measures. 1911.
<b>5518</b>	(9374)	Near Manor Bridge, Kingsdale Beck, Ingleton.	Fault. 1911.
<b>5519</b>	(9377)	Mason Hill, near Ingleton	Upper Permian Conglomerate. 1911.
<b>5520</b>	(9640)	Hambleton Quarry, near Bolton Abbey Station.	Contorted Yoredale Limestone. 1912.
<b>5521</b>	(9641)	Hambleton Quarry, near Bolton Abbey Station.	Contorted Yoredale Limestone. 1912.
<b>5522</b>	(9642)	Hambleton Quarry, near Bolton Abbey Station.	Contorted Yoredale Limestone. 1912.

*Photographed by E. SIMPSON, 44 Sefton Terrace, Beeston Hill, Leeds, and presented on behalf of the Yorkshire Speleological Association.*  
12/10.

<b>5523</b>	( )	Rift Pot, Ingleborough	. Carboniferous Limestone; Surface. 1908 (?).
<b>5524</b>	( )	„ „ „	. First Chamber. 1908 (?).

## WALES.

CARNARVONSHIRE.—*Photographed by*

L.

<b>5525</b>	( )	Criccieth Bay	. . . 'Head' and Blown Sand. 1912.
<b>5526</b>	( )	„ „	. . . Rolled masses of Boulder Clay. 1912.
<b>5527</b>	( )	Criccieth	. . . Glacial Valley. 1912.
<b>5528</b>	( )	Rhydrosiau, Criccieth	. . . Rhyolite. 1912.
<b>5529</b>	( )	Dwyfawr, Criccieth	. . . Lower Llandoverly Beds, <i>fimbriatus</i> to <i>convolutus</i> zones. 1912.
<b>5530</b>	( )	„ „	. . . Tarannon Rocks. 1912.
<b>5531</b>	( )	Near Criccieth	. . . Tarannon Rocks, <i>turriculatus</i> zone. 1912.
<b>5532</b>	( )	Wern Quarry, near Portmadoc	Middle Lingula Flags. 1912.



## ISLE OF MAN.

Photographed by GODFREY BINGLEY, Thorniehurst, Headingley, Leeds.  
1/2.

Regd.

No.

**5533** (7720) Poyll Vaaish . . . *Desmograptus monensis*. 1906.

Photographed by Col. A. C. HAYWOOD, Rearsby, Blundellsands. 1/2.

**5534** (1) Elby Point, Dalby . . . Contorted Manx Slates. 1909.

**5535** (2) " " " . . . Disturbed Niarbyl Flags. 1909.

**5536** (3) " " " . . . " " " "

**5537** (4) " " " . . . " " " "

**5538** (5) Niarbyl Bay . . . Coast Scenery. 1910.

**5539** (6) " " . . . " " "

## SCOTLAND.

ARGYLLSHIRE.—Photographed by Professor S. H. REYNOLDS, M.A.,  
Sc.D., The University, Bristol. 1/4.

**5540** (11·7) Ardnamurchan Point from Gabbro Coast. 1911.  
the S.W.

**5541** (11·8) Ardnamurchan Point . . . Dykes in Gabbro. 1911.

Photographed by the late RUSSELL F. GWINNELL, 33 St. Peter's Square,  
London, W. 1/4.

**5542** (1) Achnacroich, Lismane, Oban . . . Raised Beach, with old Sea Cliff.  
1907.

**5543** (2) " " " . . . Travertine from stream on edge  
of Raised Beach. 1907.

FIFESHIRE.—Photographed by Professor S. H. REYNOLDS, M.A., Sc.D.,  
The University, Bristol. 1/4.

**5544** (16·12) Shore S. of Rock and Dome-shaped fold in the Calci-  
ferous Sandstone Series. 1912.  
Spindle, St. Andrews.

FORFARSHIRE.—Photographed by Professor S. H. REYNOLDS, M.A.,  
Sc.D., The University, Bristol. 1/4.

**5545** (51·12) Shore, N. of Arbroath . . . Unconformity between Upper and  
Lower Old Red Sandstone. 1912.

**5546** (52·12) " " " . . . Unconformity between Upper and  
Lower Old Red Sandstone. 1912.

**5547** (53·12) " " " . . . Marine erosion of Old Red Sand-  
stone. 1912.

**5548** (54·12) " " " . . . Mouth of Blowhole, 'The For-  
bidden Cave.' 1912.

**5549** (55·12) " " " . . . Blowhole, 'The Forbidden Cave.'  
1912.

INVERNESS-SHIRE.—Photographed by Professor S. H. REYNOLDS,  
M.A., Sc.D., The University, Bristol. 1/4.

**5550** (11·12) Eigg from the S.E. . . The Sgurr of Eigg. 1911.

**5551** (11·16) Lochalsh . . . Overfolded Torridonian rocks and  
Murchison Monument. 1911.

**5552** (11·17) Kylerhea, Skye . . . 100 ft. Raised Beach terrace. 1911.



PERTHSHIRE.—*Photographed by A. S. REID, M.A., F.G.S., Trinity College, Glenalmond. 1/2.*

Regd. No.				
5618	(13)	Loch Lubnag, near Callander	Delta of Balvag River.	1916.
5619	(12)	" " "	" " "	"
5620	(15)	" " "	" " "	"
5621	(14)	" " "	" " "	"
5622	(4)	" " "	" " "	"
5623	(3)	" " "	" " "	"
5624	(8)	Lochs Doine and Voil, near Callander.	Delta of Monachyle Burn dividing one Loch from the other.	1916.
5625	(7)	Lochs Doine and Voil, near Callander.	Delta of Monachyle Burn dividing one Loch from the other.	1916.

ROSS-SHIRE.—*Photographed by the late RUSSELL F. GWINNELL, 33 St. Peter's Square, London, W. 1/4.*

5579	(3)	Black Rock Gorge, Novar, Cromarty Firth.	Gorge eroded along Joint plane in Old Red Sandstone.	1908.
5580	(4)	Black Rock Gorge, Novar, Cromarty Firth.	Gorge eroded along Joint plane in Old Red Sandstone.	1908.

SUTHERLANDSHIRE.—*Photographed by Professor S. H. REYNOLDS, M.A., Sc.D., The University, Bristol. 1/4.*

5581	(21·12)	Oykell Bridge, W. of Lairg	Section of Moine Schists.	1912.
5582	(22·12)	Roadside W. of Inchnamdamff.	Torridonian Unconformable on Lewisian.	1912.
5583	(23·12)	Roadside W. of Inchnamdamff.	Torridonian Unconformable on Lewisian.	1912.
5584	(25·12)	Quinag from Loch Glencoul	Torridonian Mountain on platform of Lewisian Gneiss.	1912.
5585	(26·12)	N. side, Loch Glencoul	Glencoul Thrust, Lewisian Gneiss brought over Fucoid Beds (Cambrian).	1912.
5586	(27·12)	Head of Loch Glencoul	Glencoul Thrust bringing Lewisian Gneiss over Durness Limestone.	1912.
5587	(29·12)	Near head of Loch Glencoul.	Lewisian Gneiss.	1912.
5588	(30·12)	Inchnadamff	Durness Limestone.	1912.
5589	(32·12)	Roadside W. of Inchnamdamff.	Torridonian Unconformable on Lewisian.	1912.

## IRELAND.

ANTRIM.—*Photographed by R. WELCH,\* 49 Lonsdale Street, Belfast. 1/1.*

5630	(5218)	Frosses Bog, Ballymoney	Typical section in thick Peat.	1908.
------	--------	-------------------------	--------------------------------	-------

*Photographed by A. E. V. ZEALLEY, B.Sc., A.R.C.S., Geological Survey, Rhodesia, Buluwayo. 1/4.*

5590	(91)	Cliffs of Giant's Causeway	Curved Dolerite Columns.	1907.
5591	(93)	Part of Giant's Organ, Giant's Causeway.	Columnar Dolerite with Transverse Jointing.	1907.
5592	(103)	Fair Head, Ballycastle	Cliff of Columnar Dolerite.	1907.
5593	(106)	N.W. of Lough-na-Cranagh, Ballycastle.	Glaciated Lower Carboniferous Sandstone.	1907.

Regd. No.			
5594	(109)	Lough-na-Cranagh, Bally- castle.	Glaciated Rock-basin, erratic blocks. 1907.
5595	(111)	Murlough Bay, Ballycastle .	Glauconitic Conglomerate, resting unconformably on Trias. 1907.
5596	(116)	White Park Bay, Ballintoy .	Irregular and regular Columnar Jointing. 1907.
5597	(117)	„ „ „ .	Irregular and regular Columnar Jointing. 1907.
5598	(122)	Between Larry Bane and Carrick-a-raide, Ballintoy.	Solution grooves due to weathering in Chalk. 1908.
5599	(155)	Cushendun . . . .	Crushed Pebbles in Conglomerate of 'Dingle Beds.' 1907.

CLARE.—*Photographed by R. WELCH,\* 49 Lonsdale Street, Belfast. 1/1.*

5631	(5266)	Elder-Bush Cave, Newhall .	Entrance, Stratification, and Rect- angular Galleries. 1905.
5632	(5264)	Catacombs Cave, Ennis .	Entrance. 1905.
5633	(5265)	„ „ „ .	Interior, with Cross Chambers. 1905.

CORK.—*Photographed by R. WELCH,\* 49 Lonsdale Street, Belfast. 1/1.*

5634	(5268)	Mammoth Cave, Doneraile .	Entrance in Quarry. 1907.
5635	(5269)	„ „ „ .	Upper and part of Lower Stalag- mite Floors. 1907.

DONEGAL.—*Photographed by A. E. V. ZEALLEY, B.Sc., A.R.C.S,  
Geological Survey of Rhodesia, Buluwayo. 1/4.*

5600	(230)	Barnes Gap, Creeslough .	Weathered Metamorphosed Lime- stone. 1908.
------	-------	--------------------------	---

*Photographed by R. WELCH,\* 49 Lonsdale Street, Belfast. 1/1.*

5636	(5214)	Rosapenna . . . .	Section in Shell-sands. 1903.
------	--------	-------------------	-------------------------------

GALWAY.—*Photographed by Professor S. H. REYNOLDS, M.A., Sc.D.,  
The University, Bristol. 1/4.*

5601	(55·13)	Top of Bencorragh, Lough Nafaoey.	Pillow Lava (Spilite). 1913.
5602	(56·13)	Top of Bencorragh, Lough Nafaoey.	„ „ „ „
5603	(57·13)	Top of Bencorragh, Lough Nafaoey.	„ „ „ „
5604	(58·13)	Top of Bencorragh, Lough Nafaoey.	„ „ „ „
5605	(63·13)	Top of Bencorragh, Lough Nafaoey.	„ „ „ „
5606	(64·13)	Top of Bencorragh, Lough Nafaoey.	„ „ „ „

LIMERICK.—*Photographed by R. WELCH,\* 49 Lonsdale Street, Belfast.  
1/1.*

5637	(11169)	Castleconnell . . . .	Perforations in Limestone. 1905.
------	---------	-----------------------	----------------------------------

LONDONDERRY.—*Photographed by R. WELCH,\* 49 Lonsdale Street, Belfast.*

Regd.  
No.

<b>5638</b>	(5261)	Culbane, Portglenone . . .	Diatomaceous Clay of River Bann. 1903.
<b>5639</b>	(5262)	„ „ . . .	Diatomaceous Clay of River Bann. 1903.

MAYO.—*Photographed by Professor S. H. REYNOLDS, M.A., Sc.D., The University, Bristol. 1/4.*

<b>5607</b>	(11·10)	Derry Bay, Kilbride . . .	Ice-worn Islands. 1910.
<b>5608</b>	(12·10)	„ „ „ . . .	Clogduff, an Ice-worn Island. 1910
<b>5609</b>	(13·10)	N. shore of Kilbride Pen- insula.	Roche Moutonnée. 1910.
<b>5610</b>	(14·10)	N. shore of Kilbride Pen- insula.	„ „ „
<b>5611</b>	(15·10)	Derry Bay, Kilbride . . .	Clogduff, an Ice-worn Island. 1910.
<b>5612</b>	(16·10)	„ „ „ . . .	Ice-worn Shores. 1910.
<b>5613</b>	(61·11)	W. of Finny, Kilbride Pen- insula.	Chert in Spilite. 1911.
<b>5614</b>	(62·11)	N. of Finny, Kilbride Pen- insula.	Flow Brecciation (?) in Spilite. 1911.
<b>5615</b>	(63·11)	W. of Finny, Kilbride Pen- insula.	Strings and patches of Chert in Spilite. 1911.
<b>5616</b>	(64·11)	W. of Finny, Kilbride Pen- insula.	Spilite (Pillow Lava). 1911.
<b>5617</b>	(65·11)	W. of Finny, Kilbride Pen- insula.	Spilite (Pillow Lava) showing Con- centrically arranged Vesicles. 1911.

## APPENDIX.

## FINANCIAL STATEMENT.

As no meeting of the Committee has been practicable since 1908, there is give below a statement of the exact financial position :—

*Balance Sheet, 1910.*

<i>Cr.</i>	£	s.	d.	<i>Dr.</i>	£	s.	d.
Balance, September 1908 . . .	124	4	1	Publication expenses . . .	0	13	0
Sales published series . . .	8	5	0	Collection expenses . . .	2	6	9
				Balance . . .	129	9	4
<b>Total . . .</b>	<b>132</b>	<b>9</b>	<b>1</b>	<b>Total . . .</b>	<b>132</b>	<b>9</b>	<b>1</b>

*Interest Account since Close of Publication.*

	£	s.	d.
January 1904 to August 1908, at 2½ per cent. on £140 . . .	15	15	0
August 1908 to August 1915, at 2½ per cent. on £130 . . .	22	15	0
August 1915 to August 1916, at 4½ per cent. (War Loan) on £130 . . .	5	17	0
Balance as above . . .	129	9	4
<b>Total . . .</b>	<b>173</b>	<b>16</b>	<b>4</b>

*Balance Sheet, September 1916.*

<i>Cr.</i>	£	s.	d.	<i>Dr.</i>	£	s.	d.
Assets as above . . .	173	16	4	Subscription refunded . . .	1	5	0
				Collection expenses . . .	3	2	6
				Exchequer Bond (5%) . . .	100	0	0
				Cash . . .	69	8	10
<b>Total . . .</b>	<b>173</b>	<b>16</b>	<b>4</b>	<b>Total . . .</b>	<b>173</b>	<b>16</b>	<b>4</b>

*Nomenclature of the Carboniferous, Permo-Carboniferous, and Permian Rocks of the Southern Hemisphere.—Interim Report of the Committee, consisting of Professor T. W. EDGEWORTH DAVID (Chairman), Professor E. W. SKEATS (Secretary), Mr. W. S. DUN, Sir T. H. HOLLAND, REV. W. HOWCHIN, Mr. A. E. KITSON, Mr. G. W. LAMPLUGH, Dr. A. W. ROGERS, Professor A. C. SEWARD, Dr. D. M. S. WATSON, and Professor W. G. WOOLNOUGH, appointed to consider the above.*

DURING the past few months communications in response to the Secretary's circular letter (see last year's report in *Rep. Brit. Assoc.* for 1915, p. 263) have been received from Dr. A. W. Rogers and Dr. D. M. S. Watson, relating mainly to the classification in South Africa. Reports in reply to the Secretary's questions have also lately been received from Mr. A. E. Kitson (Gold Coast), Mr. F. Chapman (Melbourne), Mr. W. H. Twelvetrees (Tasmania), and Professor P. Marshall (New Zealand). It has been considered advisable to keep these contributions for printing along with others which have not yet come to hand owing to war conditions.

---

*Occupation of a Table at the Zoological Station at Naples.—Report of the Committee, consisting of Mr. E. S. GOODRICH (Chairman), Dr. J. H. ASHWORTH (Secretary), Mr. G. P. BIDDER, Professor F. O. BOWER, Dr. W. B. HARDY, Dr. S. F. HARMER, Professor S. J. HICKSON, Sir E. RAY LANKESTER, Professor W. C. McINTOSH, and Dr. A. D. WALLER.*

THE British Association table at Naples has not been occupied during the current financial year.

Mrs. Pixell-Goodrich has published<sup>1</sup> an account of the Gregarines of *Glycera siphonostoma*, founded on material obtained during her occupancy of the table in March and April 1914.

Intimation has been received that the administration of the Zoological Station is now in the hands of a Commission, with Professor F. S. Monticelli as President, appointed by the Italian Government. The Committee asks to be reappointed.

<sup>1</sup> *Quart. Journ. Micr. Sci.*, vol. 61, pp. 205-216, pl. xviii., 1916.

---

*Zoological Bibliography and Publication.*—Report of the Committee, consisting of Professor E. B. POULTON (Chairman), Dr. F. A. BATHER (Secretary), and Drs. W. E. HOYLE and P. CHALMERS MITCHELL.

THIS Committee represents the resuscitation of a Committee first appointed in 1895, with Sir W. H. Flower as Chairman and Dr. Bather as Secretary. That Committee reported in 1896 and 1897, and its Reports, in which a number of suggestions were made for the guidance of authors and editors, were widely distributed. Although the request of the Committee for reappointment with a small grant was not acceded to, its Secretary has continued to distribute those Reports, as well as a circular issued by the Committee, and has conducted correspondence arising therefrom. Whether or no it be in consequence of the action taken by the Committee of 1895 and thus continued, there can be no doubt as to the greater attention now paid by most publishing bodies to the points mentioned in the previous Reports. Others, however, have not yet fallen into line, and new publications, started without experience, fall into the old errors. For these reasons and also because the correspondence shows that interest in the subject tends to increase, this fresh Committee has been appointed, so as to reinvest the suggestions with their original authority, and to deal with any inquiries that may arise.

During the past year copies of the circular have been sent to the editors of two societies with satisfactory results, and several inquiries have been answered, especially from the Geological Society of Glasgow.

*Method of making References to Previous Literature.*

One of these inquiries related to this subject, which also was discussed in the pages of *Science* for October 1 and November 12, 1915. On this matter the Committee begs to offer the following suggestions:

The question is: What is the best way in which the author of a paper can introduce references to the works which he quotes or otherwise alludes to? No single method suits all cases. At the outset a distinction must be drawn between two classes of papers: first, brief articles, in which the references are correspondingly few and rarely repeated; secondly, long articles or memoirs, in which the references are correspondingly numerous and frequently repeated.

In articles of the first class, references may quite easily be worked into the text, and can be repeated by giving the cited author's name, with a distinguishing date when more than one of his works has been mentioned: This is more economical of time, space, and money than footnotes, and is far less fruitful of error than the irritating *ibid.* and *loc. cit.*, often used by writers who apparently do not know what the contractions really mean.

For memoirs of the second class, it is more convenient for both author and reader to have, either at the end or at the beginning of the

memoir, a 'List of Works referred to' (often erroneously termed a 'Bibliography,' even when lamentably lacking all bibliographic details). This should be arranged with the names of the authors in alphabetical order, and with the papers under each author's name in chronological order, the date of publication (month as well as year, if necessary) preceding the title of the paper. In those rare cases when two or more papers by a single author from a single year cannot be distinguished by the month, the letters *a*, *b*, &c., may be added. Examples:

LAMBERT, J. Jan. 1900. Étude sur quelques Échinides de l'Infra-Lias. *Bull. Soc. Sci. Yonne*, LIII., 3-57, pl. i.

MEYER, H. von. 1849*b*. Ueber die Laterne des Aristoteles. *Arch. f. Anat.*, Jahrg. 1849, pp. 191-196, pl. ii.

The references in the text will give the name of the author followed (or preceded) by the date, with the addition of a precise page-number where required. Examples:

'*Mesodiadema simplex* LAMBERT (Jan. 1900, p. 31), Middle Lias.'

'The term *Schaltstück*, used by H. v. MEYER (1849*b*), is open to objection.'

'So early as 1787, A. PARRA observed the epiphyses.'

The plan of arranging and numbering the quoted works in the order in which they happen to be mentioned in the text, and of referring to them by the number, saves trouble to nobody except the writer of the paper at the moment of writing. The method here advocated is nearly, often quite, as brief; it gives the historical perspective, and it is of itself enough to save a reader familiar with the subject from repeated application to the list at the end.

The system is essentially the same as that introduced by Professor E. L. Mark in October, 1881 (*Bull. Mus. Comp. Zool. Harvard*, VI., 232, footnote), and recommended in March, 1894, by H. H. Field (*Bull. Soc. Zool. France*, XIX., 44). Those authors, however, write '81 and '94, instead of 1881 and 1894, a system that could only have been defended had our science begun and ended with the nineteenth century.

As bearing on this particular question, the Committee would repeat two suggestions made in 1897. First, that the title of a paper (or at least its opening words) should be quoted, as well as the name of the journal from which it is taken. Secondly, that references should be given in full (*i.e.*, series, volume, pages, date), so that an error in one may be corrected by the help of the others.

The Committee asks for reappointment, and wishes to state that any inquiries or suggestions will be welcome, and should be addressed to its Secretary at the Natural History Museum, Cromwell Road, London, S.W.



*Political Boundaries.*By Colonel Sir T. H. HOLDICH, *K.C.M.G., K.C.I.E., C.B.*[Ordered by the General Committee to be printed *in extenso.*]

It is said that more wars have been caused by boundary disputes than any other source of political contention. Whenever there is a war, there is, inevitably, a boundary violated somewhere or other as the direct result of military movement, but this is an effect rather than a cause. The cause is to be sought for amongst a great complexity of human motives—it may be a spirit of aggression, the sheer lust of world power, or it may be and frequently is an irrepressible demand for more space for an expanding people. This everlasting changing and shifting of boundaries which, whether regarded as cause or effect, is the accompaniment of every great world war would, one would have thought, have led long ago to a most careful consideration of the principles which should govern the setting out of boundaries between nationalities in such manner as to render them the most efficient factors in the preservation of peace; and yet the amount of really useful literature on this subject is almost infinitesimal. The complexity and importance of it has, I think, hardly been realised, and certainly no other subject could lend itself better to scientific discussion from either the military, political, or the geographical standpoint, or start more free from preconceived notions and dogmatic opinion. One or two able writers have indeed attempted to define the requirements of an international boundary from a theoretical point of view in a manner which is wholly admirable in so far as it is based on a belief in the regeneration of humanity, and the existence of an honest desire for a millennium of peace and goodwill which should lead nations to dwell together in unity. Unfortunately there are very few signs of this happy tendency in these days. It does not much matter in what direction you look for signs of yearning loving kindness amongst people, who, being ordered and ruled from separate and distinct centres of government, still exist as rivals in the great world field of commercial development and wealth hunting; you will not find them. In no direction whatever are such symptoms significant enough to warrant the adoption of any scheme of boundary fixing which would lead to the commingling of the human fringes of the nations and promote mutual assimilation in a spirit of brotherly love and common ideals. Here we are faced with one of the difficulties which beset the discussion of the subject. What is a nation? or rather what are those conditions of government and geographical environment which constitute the basis of a nationality, binding all its individual members into one definite and complete whole in the consciousness of unity of purpose and ideals? An American writer defines a nation as ‘a population of an ethnic unity, inhabiting a geographic unity under a common form of government.’ He is careful to add that the exceptions are quite numerous enough to prove the rule. We had better leave it at that, and remember that under the universal political empires of the past there were no nations; and that with the increase of democracies in the world will come an inevitable increase of international boundaries. It is, however,

with the spirit of the nation, the sentiments which underlie its national ideals, that we have to deal in practice when laying out a line of separation, and this, so far as it affects boundary settlements between civilised communities, appears at first sight to be a very complicated problem. The bonds of ethnic affinity; a fervid community in religious sentiment; a mutual basis of agreement and aim as regards cultural development, or political aspirations, have all been cited as sentiments strong enough to ensure such a peace-loving and peace-promoting assimilation as should render the existence of a dividing line a merely nominal geographical incident. As a matter of fact none of these sentiments weigh for an instant against a certain form of fervid patriotism, which is a virtue inculcated by education and supported by the irresistible effects of environment and self-interest. I do not mean to say that self-interest is at the root of patriotism, but I do mean to say that it is very easy to place self-interest on a very high pedestal of morality, and then to imagine that it is patriotism; and that it is a matter of the very deepest concern to any Government which values the great principle of love for one's country, and the spirit of self-sacrifice in that country's cause, to see to it that the highest patriotic ideals, whilst yet uncontaminated by the breath of self-interest, are fostered and inculcated during the earliest phases of education. It might be thought that community of origin and of language would be a powerful agent in the promotion of peace between peoples who share it. Unfortunately, it seems to count for little or nothing when boundary disputes arise. Such international family quarrels are often the bitterest, nor can we say that community of religious faith is any stronger as a binding agency than community of language and ethnical affinity. Such influences may almost be ignored, as well as those which arise from common aspirations after certain forms of culture, when men's passions are aroused by the greed of territorial expansion or the bitter grievance of its curtailment. It is quite sufficient for all practical purposes if we lump all such matters of sentiment together and regard the total effect of them as the will of the people. The will of the people is, in effect, the outcome and expression of all these influences, together with that greater, nobler, and more inspiring sentiment which the Japanese know as 'bushido,' and which we call patriotism. I have been concerned officially in the settlement of many boundaries, but never have I experienced (nor have I ever heard of) a settlement in which the people concerned on either side were so happily disposed towards each other as to ask only for a fair division of interests, and such a nominal hedge between them as would permit of neighbourly fraternisation and the interchange of courtesies. On the contrary, boundary disputes seem to possess quite an unreasonable, and sometimes incomprehensible, faculty for stirring up the very worst elements of international hatred and passion, and we are forced to the conclusion that a boundary settlement involves the partition of conflicting interests which must be adjusted as far as possible so as to prevent those interests from ever clashing or morally interfering with each other again. So long as man is a fighting animal he must be prevented from physical interference with his neighbour by physical

means. I grant that this is not a high ideal, but what else can we suggest? We have had bitter experience of late years which should teach us again an old, old lesson of the value of high ideals and altruistic sentiment where men's passions are concerned in this unredeemed world so full of beauty and of desperate evil; and we must reluctantly admit that the best way to preserve peace amongst the nations is to part them by as strong and as definite a physical fence as we can find. In short, a boundary must be a barrier, and the position of it must be influenced largely by the will of the people. These, then, are the two governing conditions of boundary making. Let us consider the latter condition first. All authorities seem to agree (there are not many of them) that the annexation of any territory directly against the will of its inhabitants is a political blunder. The assimilation of its people with the conquering nation is a slow, and often an impossible process. The Germans have not assimilated the French of Alsace and Lorraine, the English have hardly assimilated the Irish, and where race antagonism is believed to be supported by self-interest real assimilation seems to be hopeless. An admixture, so to speak, may be effected mechanically, but real chemical fusion never takes place. Under such circumstances it is seldom indeed that the acquired territory is a safe and thoroughly sound unit in the political entity. It adds little or nothing to the strength of a nation, although it may be economically useful, and it is apt to be a very thorn in the side of any Government and an undoubted danger in times of stress and adversity. The expression of the peoples' will varies infinitely in form. In the savage and uncivilised countries of the black man there may be no possibility of consulting it. The questions at issue may lie between whole nations, and the black man has little to say to the disposition of his own property. But amongst civilised countries there is always a 'will,' and it is usually exceedingly definite. Various suggestions have been made as to the best way of ascertaining that will. A plebiscite even has been suggested. I cannot imagine a surer way of starting an armed conflict. The process of vote-catching is never one which lends itself to the promotion of good feeling and brotherly love at the best of times, even when the object is a political issue only half comprehended. When it is a matter of close personal interest involving a clear issue of local gain or loss it certainly would stir up to its very depths the identical dispute which the boundary is planned to decide. Nor in practice will it be found that any such resource is necessary. However complicated may be the admixture of those sentiments which together combine to form a definite will on the part of the disputants, the expression of a people's will in terms of the majority is usually definite and unmistakable. When opinions are fairly divided and the expression of them is weak and wobbly, inclining first one way and then another, weighing advantages against disadvantages, and coming to no decided conclusion, then indeed sentiment may well be allowed to give way to those physical conditions which should govern the selection of the line of partition, strong geographically, a barrier for defence against aggression, an age-long guarantee for the peaceful development of culture and commerce without interference or fear on either side. Let

me repeat that the reason for giving first consideration to the sentimental values in a boundary dispute is the obvious fact, long ago confirmed by history, that no nation gains in strength by the acquisition of a people latently hostile, and prevented by hereditary or ethnical instinct from any process of assimilation which will cement the bonds of political union. Setting aside, then, the question of international sentiment, we may consider those problems which beset the physical side of the questions, especially the relations and influence of geography and environment on a frontier, together with some few of the most important rules which should guide first the delimitation, and then the demarcation, of a boundary, and I should like to commence by insisting, as far as I can, on some definitions which seem to be called for, judging from certain reports dealing with boundary matters which I have lately read, and on which I have been asked to express an opinion. The 'delimitation' of a boundary is not the actual process of marking out its position in the field. That is better understood by the word 'demarcation.' Delimitation is a process of defining by means of maps and protocols where a boundary should be demarcated in the field, and it is usually the function of those high political authorities who meet together to represent the interests of either nation concerned and agree, on such geographical evidence as they can get, what either side is prepared to accept. Too often it is assumed that with the delimitation of a boundary the great question at issue is finally settled. If the delimitation is based on perfectly sound evidence, and if the protocols and other technical documents provided for the guidance of the demarcators is expressed both clearly and correctly, the subsequent business of demarcation becomes merely a secondary process giving effect in the field to that which has been decided in high conclave. This has seldom been the case in the past owing to a want of appreciation for the necessity for exact geographical knowledge, both practical and theoretical, on the part of the political delimitors, and it has happened that the terms of delimitation have led to far extended disputes and to a process of demarcation which, in one important instance at least, has lasted for more than a century and a half. Another matter on which some confusion of mind has been apparent, even amongst officers of special ability in this form of public service, is the distinction which lies between a frontier and a boundary. If you define this distinction shortly it amounts to this—a boundary denotes a line, and a frontier space. The boundary limits the frontier, and it is the expansion of the frontier which so frequently renders a boundary necessary; a frontier is but a vague and indefinite term until the boundary sets a hedge between it and the frontier of a neighbouring State.

There are, in my opinion, certain fixed principles which are applicable to all boundaries no matter where they may be traced, whether among the gloomy forests of the Upper Amazon or the peaks and pinnacles of the Andes, amongst the sun-baked hills of Africa or through the intricacies of the rugged borderland of India; whether in black man's wilderness or the white man's populous and overcrowded provinces; and these principles, which are dependent on physical attributes, can never be safely ignored. The last half-century has

witnessed a perfect orgy of boundary making, and latterly the demand of scientific requirements (notably of geographical exactitude in definition and demarcation) have been fairly met. We can certainly claim that of late years our boundaries have been shaped scientifically by competent demarcation guided by the text of delimitations which, if not technically perfect, have at least been free from the ridiculous elementary errors of past generations of politicians, who were ignorant of the very first principles of geography. I need not weary you with any repetition of past mistakes, mistakes that have cost us the value of many millions sterling, and have more than once reduced this country, as well as other countries, to the verge of war. I have referred to them often enough elsewhere. It is quite probable that we shall ere long be faced with a comparatively new phase of boundary problems where there can no longer be the excuse of want of sound map knowledge of the districts concerned to account for misleading and inaccurate delimitations, but where ethnical interests of the most important character will possibly present painfully complicated knots for disentanglement. In no case, however, can I imagine that the wishes of the majority of the people concerned will be difficult to ascertain, and in certainly the great majority of cases it will be those main principles involving physical attributes which will prove to be the most important factor in the settlement. We should, in the first place, be absolutely certain, that on both sides of the settlement there is the same governing idea of a contract which is to secure the permanent peace of the border. Whilst this is the just and righteous aim of the boundary maker, whilst he has nothing in view but that which is to develop the influences of peace and the interests, commercial and cultural, of the peoples between whom he has to set a hedge, he must beware of any reservation which may become apparent during the process of settlement which would indicate that a loophole is to be left in that hedge through which advantage may be taken hereafter, when the hour shall strike, of some weakness which may facilitate a sudden and determined overthrow of the whole construction. In the strongest sense of the term, then, I must insist that a boundary must be a sound and unbroken barrier as far as possible, and that it must be selected most assuredly with the great object in view of hindering in every possible way any proposed scheme of violation. As a barrier it may be natural or it may be artificial. In either case it must be made as secure as Nature or Art can make it. Peace can only be based in this imperfect world on security. Security, as one able writer has justly put it, means 'armament.' In blood and tears have we at last learnt this lesson. May no specious notions of a new millennium blot it out from our minds, and may our political representatives, impressed at last with the lessons of the War, set about designing new political boundaries with lines as strong as they can be made. Prevention of war is much better than cure; better by the lives, it may be, of millions of brave men and the tears of thousands of women, and it may quite easily be prevented to a very appreciable extent by limiting the capacity of angry disputants to get at each other. How are we to secure these strong boundaries? To a certain extent Nature helps us, and where Nature

steps in with a really sound and impracticable fence nothing in the world can be better. Almost every geographical feature has already been impressed into the service of the boundary maker. We have mountain ranges, rivers and lakes, seas and deserts, all doing duty, to say nothing of countless minor features which make up the topographical plan of the earth's surface. Incomparably the best of these are mountain ranges. It may happen that they stand alone, untouched for miles by artificial designs as great and impassable border lands, in the midst of which the boundary follows the great divides, majestic, unapproachable, immovable, subject to no vicissitudes of natural force short of violent earthquakes, requiring no artificial boundary marks for definition, no ridiculous waste of money over demarcation, no expenditure in boundary upkeep, presenting on either hand a magnificent wall of defence, unbroken, impressive, defiant. It is true that here and there across all the great mountain systems of the world there run the tortuous and narrow ways culminating in passes connecting the wide plains on either side. Over these passes and through their narrow ways armies have been conducted from time to time, and history records several notable instances of great invasions conducted across great mountain systems, but I venture to think this is not a phase of history which is likely to repeat itself. The power of scientific defence forbids it. Under such circumstances opportunities for transgressing the boundary and trespass into foreign fields are not many, and the trespassing is a matter which entails serious consideration and the delay of preparation. I need not enlarge on the value of mountain boundaries. You are all familiar with such notable instances as the great wall of the Pyrenees, the more intricate Alpine system, and the magnificent Continental divide of the Andine Cordillera, all of which have been pressed into international service; but to my mind the most amazing natural boundary in the world is that of the snowy Himalayan ranges which part India from the great northern uplands. These ranges, combined with the important offshoots of the Hindu Kush and its extensions, absolutely and securely hedge in India from any northern threat of invasion, leaving but one comparatively short north-western gateway doubtfully available through the whole wide extended frontier between Burma and Persia. If we cannot guard that gateway we had better leave India. Next to an impressive mountain system we must be content with lesser divides, lesser in altitude, and inferior in the quality of difficult approach. If we cannot have Himalayas we may make good use of Carpathians. I need hardly refer to the excellent use which has been made of this formidable, but by no means unapproachable, mountain system, not only historically, but notably during the varying phases of the present war. The Crown Colony of Galicia, lying flat beyond these mountains, has proved to be nothing but weakness to the Austrian Empire, which has been forced to defend her south-eastern frontier by the Carpathian ridges rather than by the fortresses and rivers of Galicia. Whatever may be the significance of the mountain system as a geographical divide between the nations, it is of obvious importance that the actual boundary should follow the parting of the waters. To take a remarkable instance of the weakness

which results from a failure to observe this condition I may refer to the northern Italian frontier. Here the main watershed has been intermittently abandoned; valleys are crossed; local interests are divided; racial and social affinities are disregarded; mountain crests are traversed with an air of readiness which betokens a nominal rather than an actual boundary, and a permanent international grievance has been established which this war may, or may not, set right.

Failing a definite uplifted watershed, the ordinary divide between the heads of minor affluents of a river basin is quite a useful alternative. The advantages are those of permanence, definiteness, and economy, added to a certain command in altitude which renders it important as a military feature. It is seldom that a divide alters its position from the action of natural causes: on the whole it may be regarded as a permanent feature unlikely to be shifted or affected by the wear and tear of nature's destructive forces; and it is definite and often unmistakably recognisable without the aid of artificial landmarks, which cost money and are perishable. Consequently, it is readily and quickly adapted to the purpose of boundary making. Judging from the map of Europe, it may be said that these advantages have not been overlooked in the past. To a very great extent it is the divide between the rivers, and not the rivers themselves, that have been adopted for international purposes. Rivers, perhaps, rank next in value to mountain chains, and they certainly play an important part in the great political partitioning of the world. They are at least unmistakable and definite features requiring little artificial assistance; and they do often serve the purpose of a barrier. Indeed, it entirely depends on the conditions of environment whether a river makes a good boundary or a very bad one. Where the surrounding country is a waste of trackless forest or of wild upland, and where the river is confined to a narrow channel in a rock-bound bed, it may be admirably adapted for a boundary. The Oxus, from the plains of Badakshan to its glacier sources in the Pamirs, forms a typical boundary of this nature; but where it leaves the hills and, spreading into the plains, it changes its banks and its channels, swallowing up acres of good alluvial soil here, pushing up sandbanks and islands there, and laying out new islets or streamlets which wander irresponsibly over the surface of the plains confusing the issue as to what are its banks, it forms no boundary at all. Moreover, where it is broad enough and deep enough to warrant navigation, it has a tendency to lapse into the exclusive possession of the most pushing nation.

The Oxus of the plains from Charjui to Badakshan has become a Russian highway. The Rhine, when indeed it formed a boundary, was always claimed as 'our river' by the Germans. Rival claims for right of way and disputes about land or local irrigation claims are far more likely to arise from the common possession of an intermediate river than the friendly interchange of civilities and international amenities. When the Germans shifted their boundary from the Rhine to the Vosges Mountains they strengthened their own frontier greatly, whilst incidentally they also strengthened that of France, as we have every reason to know. The strength of the German frontier lies in

the Vosges and the heights above the Meuse, not in the Meuse, the Moselle, or the Rhine. The annexation of the provinces of Alsace and Lorraine did nothing to damage the efficacy of their national frontier from the military point of view. It rather improved it. That it proved to be a great political blunder is due to German incapacity to appreciate the force of that fundamental consideration which deals with the will of the people and their national incapacity for assimilation.

Lakes and deserts play approximately the same useful part as barriers between rival States. In Europe, Africa, and America lakes have been largely claimed in support of boundary demarcation and, like deserts, they have on the whole proved efficient, even if the exact position of the dividing line is but ill-defined in their midst. There is, indeed, this great advantage about both of these geographical features: it is seldom matter of importance that there should be exact demarcation. There may be islands in lakes, or oases and wells in deserts which have to be accounted for in the partition; but beyond them in the great wide sweep of inland water or the sand spaces of a sun-dried wilderness there is seldom the necessity for striking a distinct artificial line. It would be interesting had we time to trace a geographical analogy between a desert frontier and a sea frontier; and to show how it has happened that through long ages of history a desert-girt land of promise and development has owed continued peace and progress to its environment just as much as a sea-girt island. It may happen that no geographical features of any significance are available for the satisfaction of the boundary maker, and that continuous and obvious artificial means have to be employed to make a boundary plain. Even with the best assistance of nature artificial methods of marking a boundary will always be necessary where man's own artificial impress on the earth's surface is encountered. Passes over the heights and roads traversing less conspicuous divides have to be denoted, and the gateways of a country or a State demand careful acknowledgment, but independently of such obvious points, on which it is not necessary to dwell, it very frequently happens that for thousands of miles the natural features (whether divide or river) are not marked enough to advertise the existence of a boundary without a line of pillars or marks of some sort at distances of intervisibility. A divide even may include marshy flats from which rivers drain in opposite directions, or cultivated areas may intervene, so that at the best of times there is no getting away from artificial expression altogether. It is, however, the employment of means such as are wholly and purely artificial, where nature not only has no hand in the arrangement, but where her gentler efforts are traversed and discarded that so many ridiculously bad boundaries come to grief. The straight line, for instance, whether it represents a parallel of latitude, a meridian, or just a line projected on some particular bearing, is almost invariably bad. It possesses no elasticity, it is often most difficult to determine, it is expensive, and terribly tedious in the process of evolution. It may cut in two local interests of great importance and play the mischief with a well-defined frontier. The worst mistakes in delimitation have occurred where a meridian (undetermined by exact geodetic measurement) or a parallel



of latitude has been the weak resource of an ignorant arbitration which is dealing with a strictly geographical problem without waiting for proper geographical illustration. A straight line is generally an indication of geographical ignorance, a last resource when topographical information is wanting, so that it need not surprise us that it has in the ignorant past been distinctly popular. It has always proved to be immensely expensive, and I could occupy your time for hours in recounting historical instances of its adoption, with the evil financial results thereof. It is, however, to the credit of European diplomacy of the past that there are not many straight lines in Europe; there has indeed been no excuse for them, for there cannot be many square miles of the Continent that have not served as the basis for military action leading to a certain amount of exact topographical knowledge since Cæsar first conquered Gaul. What interests us at present chiefly is that particular phase of boundary making in the future which is to provide for the security and, through security, for the peace of the quasi-civilised communities of Europe and the Near East. If I am right in assuming the general principle governing the selection of a boundary line to be that of securing a barrier, clearly we are landed at once in questions of military defence as a necessary corollary.

At the present time the principle for which we are fighting is that of maintaining the integrity of small nations; and the principle which apparently tends to govern the evolution of national societies, both small and great, is that of the democracy. As democracies increase, and Empires are restricted, so will boundaries, together with the division of international interests, increase; but it must be remembered that the bed-rock of all social evolution is the everlasting question of population. Thus the right of expansion in order to meet the imperious demand of multiplying people will promote boundary disputes and frontier wars as long as the world lasts. So that the security of a frontier is a matter of increasing importance in the world's economy, inasmuch as we can never expect an international convention to regulate the output of population in the same way that the output of armament or ships may be regulated, although one is just as important as the other in the interests of peaceful international evolution.

What, then, is to be the nature of the political boundary of the future from the military point of view if we wish to attain the security which is the only guarantee (and which will continue to be the only guarantee) for peace? So far, as regards the actual line which denotes the boundary and limits the frontier on either side, there will be no great departure from those principles of selecting strong natural features to which I have already alluded, and these natural features will in most cases lend themselves readily to military defensive purposes. Consequently, we may assume that the mountain ridge or the divide will be adopted wherever possible. If we have learnt anything from the war, we have learnt the enormous advantage to defence which is given even by a slight command in altitude. It is true that river flats and marshes have figured largely in the strategy of the war in Poland, on the Russo-German frontier, and in Mesopotamia; and that the skilful use of marshes and inundations has largely affected the results

of the campaign; but we may very safely say that no such accidents of topographical configuration would ever be selected as the basis of a boundary in preference to the advantages conferred by an elevated line. An open space of marshland, even if traversed by a definite river channel in its midst, could not often occur in European configuration as a useful alternative to the divide, so that I do not imagine that in the redistribution of political boundaries at the close of the war, no matter where they may take place, will there be any great departure from the old order which adopted elevations and placed strong fortresses at intervals to guard frontiers. Nothing has occurred which need shake our faith in the value of this military precaution for the security of the frontier. Where the dividing line is unsupported by strong geographical features, such as are of themselves of military significance, the construction of fortresses, wherein may be gathered large military forces of sufficient strength to render it impossible to pass them by or ignore them, will still be considered imperative. It was the strength of the line of French forts from Belfort to Verdun facing the Vosges Mountains and the Meuse which determined the initial strategy of the German campaign, and directed the advance through Belgium as indicating the line of least resistance to Paris. It was the gallant defence of Liège which destroyed the full effect of the great initiative and gave priceless opportunity for mobilisation to the Allies. It is the Rhineland fortresses, and not the Rhine itself, which will protect the western frontiers of Germany when the hour comes for France to strike back. The unexpected collapse of Antwerp, of Namur, and of Maubeuge does little to modify this opinion. I shall be surprised if in the long future history does not point to the defence of Verdun as the pivot on which the fortunes of the war turned. Along with fortresses and with the controlling system of railways (with which we cannot be concerned just now) there will be new developments on or near the boundary which will be the outcome of present experiences. The rôle of trench-digging and of earthworks, which is comparatively new to European campaigning and which has time and time again proved the one insuperable obstacle to rapid advance, will not be lost sight of or neglected in favour of more impressive permanent works. Boundaries will be selected that admit of the linking up of natural features by a tracery of trenches and field works, infinitely intricate, whilst artillery and all the mechanical paraphernalia of war with which we have lately become familiar will find their place in the general scheme. Indeed, it seems that the European boundary of the future will be something more than the artificial impress of a line on the face of Europe, having no further significance than that of a hedge. It may well become an actual military barrier bristling with obstruction and points of steel, so complete and effective in its appointments as to approach very closely to realising an ideal of absolute security. Thus will it really serve to diminish the probability of attack, and at any rate to induce long and very careful consideration before its violation is undertaken. It may be said that I am suggesting a defensive fence round every State that has any consideration for its own security such as might prove a serious bar to the exchange of friendly amenities.

I fear that it is so; but my suggestion only indicates that which will, it seems to me, inevitably happen. Anyhow, it is freely open to discussion, and I claim to do no more than briefly outline the principles which, I consider, must govern a subject on which there has been so far singularly little opinion expressed.

*The Question of Fatigue from the Economic Standpoint.—Second Interim Report of the Committee, consisting of Professor J. H. MUIRHEAD (Chairman), Miss B. L. HUTCHINS (Secretary), Mr. P. SARGANT FLORENCE (Organising Secretary), Mr. C. K. OGDEN (Special Investigator), Miss A. M. ANDERSON, Professor CHAPMAN, Professor STANLEY KENT, Dr. MAITLAND, Miss M. C. MATHESON, Mrs. MEREDITH, Dr. C. S. MYERS, Mr. J. W. RAMSBOTTOM, and Dr. J. JENKINS ROBB.*

## CONTENTS.

	PAGE
Introduction . . . . .	251
I. Accumulated Fatigue in Warfare . . . . .	253
II. Daily Course of Fatigue in Type-setting . . . . .	256
III. Fatigue as a Cause of Accidents . . . . .	258
IV. The Applicability of Psychology to Problems of Industrial Fatigue . . . . .	262
V. Bibliographical Material . . . . .	270

*Introduction.*

THE publication of the first (interim) Report of the Committee of the British Association appointed to investigate 'Fatigue from the Economic Standpoint' has aroused interest both among the general public and among business men. As the Committee was appointed with the definite practical aim of influencing industrial organisation, it has tried through its Investigator to keep in touch with the attitude of practical organisers to the subject during the past year. Public reference to Fatigue has therefore as far as possible been noted. The reception of the Report itself showed that the publication occurred at a moment when scientific discussion was felt to be a necessity owing to the conditions of overtime, night work, Sunday work, and women's employment in the munition industry. The matter was particularly taken up in the leading trade papers; in many cases correspondence ensued, in which managers, foremen, and others contributed their experiences. The appointment by the Minister of Munitions of a Committee to deal with Industrial Fatigue and Health of Munition Workers early in September gave additional stimulus to the study of the subject, and in the Memoranda published by this Committee our interim report was frequently mentioned.

The Medical Research Committee of the National Health Insurance, indeed, decided itself to promote investigation, which proceeded on the lines developed in our 1915 Report—namely, by the collation of actual factory statistics. The danger of overlapping has, however, been

avoided by the fact that the investigators have been conversant with one another's work, and a line of demarcation was drawn whereby the Medical Research investigation continued on the lines of our first Report while the British Association Committee approached the separate problem of accumulated fatigue, and concentrated more particularly on questions of method, endeavouring also to facilitate the co-ordination of previous investigations, and compiling a complete Bibliography of Fatigue in all its aspects, which should be of the greatest assistance to students in the future. This laborious task has been rendered yet more formidable by the interruption of communications with the Continent, but the resources of the University Library and the Psychological Library at Cambridge have once more been freely drawn upon. This Bibliography, already comprising close upon 1,000 entries, under the threefold classification of years, subjects, and authors, has not yet reached the final stage necessary for publication; but, as an example, is submitted the list of entries classified under the heading 'General,' that is to say, dealing with the whole subject rather than with any special aspect.

Owing to circumstances also arising out of the continuance of hostilities, memoranda on changes in factory hours and the experience of managers promised by members from their various localities have been held over, and the present Report is based for the most part on research undertaken by the Investigator (Mr. C. K. Ogden) and by Mr. P. S. Florence. The co-operation has been secured, amongst others, of Professor Lee, of Columbia University, Mr. Cyril Burt, Psychological Adviser to the L.C.C., Miss May Smith, of Cherwell Hall, Oxford, and Mr. E. J. Dingwall, of the Cambridge University Library. The effect of Fatigue on Women Workers is being studied by Miss A. M. Anderson, Chief Lady Inspector of Factories, a translation has been made of those portions of Bücher's *Arbeit und Rhythmus* that are relevant to modern industrial conditions,<sup>1</sup> while Miss B. L. Hutchins has presented a memorandum reviewing the steps by which public attention has been gradually directed to the effects of fatigue in production.

The Committee was appointed in the first instance to consider the problem of Fatigue from the Economic Standpoint. This might have been interpreted only to cover the effect of fatigue upon the output of particular groups of workers. But the Committee has felt from the beginning that behind this there was the larger question of the effect of fatiguing employments on the general health of the working population, the frequency of sickness, the period of industrial efficiency, the mortality rate in particular industries. Difficult though this investigation is, the Committee has thought that it ought not to be shirked; and in the attempt to deal with this problem under the title of accumulated fatigue they are able to present a memorandum (Section I.) from Dr.

<sup>1</sup> The effect of rhythm in enabling the organism to perform with ease an amount of work which, if it were absent, would cause acute distress and fatigue is well known, as for instance in the ground covered by fragile people at a ball. The noise, regularity, 'swing' and team-work of so many processes in modern industry present very favourable ground for the application of rhythm, and the Committee have already made studies of some of its aspects.

Gwynne Maitland, who during the war in Serbia has had special opportunities of observation; while the co-operation has been secured of Professor T. Loveday, of Armstrong College, Newcastle-on-Tyne, and of Dr. Major Greenwood (Statistician to the Lister Institute). They submit their results rather as an indication of what the Committee hope to achieve in the coming year than as claiming completeness in their present form.

## SECTION I.

*Accumulated Fatigue in Warfare.*

Dr. MAITLAND.

The present war supplies unlimited material for the study of fatigue, but there is little opportunity afforded for experimental examination; one must for the most part be content with clinical observations.

There is one outstanding advantage in these cases as compared with civil cases; it is that they show much greater severity, and so enable one to realise to what extent fatigue may be responsible not only for functional disorders, but ultimately for permanent constitutional lesions.

There is, however, this great disadvantage, that there is no opportunity for submitting these, as one can submit civil cases, to experiment. It is obviously impracticable to be in the position and to select the opportunity for measuring work before and after the strain of field and trench work.

By experience of work in the field and by the observation of cases, useful conclusions can be reached, and some measure of reform has already been forced upon the Army.

The soldier has a limited capacity for work, but if he has been carefully trained that capacity may be increased; on the other hand, if his capacity is exceeded, and recuperation is not permitted to him, that capacity may undergo so much diminution as to render him quite unfit for military purposes.

Military necessity, the impossibility of bringing up relays for replacement, the inability to provide sufficient rest and uninterrupted sleep, prevent the Army from getting the greatest possible value out of the unit.

It was, indeed, found that long-continued trench strain resulted in cases of breakdown which certainly recovered after a period of rest, but such cases were left with a shorter period of utility on their return to the trenches, and, breaking down again, frequently discharged as of no further use. Not only was the period of activity shortened, but the quality of their work deteriorated, as evinced by their inaccurate shooting, by their inability to time hand-grenade fuses, by hesitation in matters which demanded quick and intelligent decision, and in various other ways.

In estimating the predisposing factors causing the acute cases of fatigue it would have been of the greatest importance to classify the various field operations in such a way as to obtain a common denominator, whereby forced marching, trench-digging, gun-moving, stretcher-bearing, and so on, might be schematised, and an ideal number of hours

allotted to each task. Unfortunately, of course, the actual strain involved varies with the occasion, and the matter is further complicated by various other conditions, such as the time and amount of the place for rest and sleep, the adequacy and sufficiency of food, the amount of noise and sensory disturbances generally, and the nervous strain of exposure to fire, and so on.

It is obvious we must therefore dispense with the hope of obtaining an ideal working day for each military unit.

All that we can reasonably hope for is that, with the present greater ability to supply reinforcements, we can diminish the strain as well as more frequently replace the actual fighting units; and it becomes a matter of the greatest urgency that with this ability, and with the growing delicacy of perception in the anticipation of the breaking-point, a greater discretion might be employed to prevent it.

Now we have two degrees of acute fatigue always coming up for notice. The one is the occasional case which is sent to the rear in a state of collapse.

The case is often confused with shock, and in some respects it resembles a case of shock: there is extreme pallor of the face, the extremities are cold, and there is a fine muscular tremor. The blood pressure of the brachial artery in such a case is very low, usually below 80 mm. Hg, the pulse is thready and the heart sounds are feeble and fluttering. It is, in fact, to be distinguished from shock only by its history and course.

Now, such a case follows the usual physiological course. Thus, after compensation has been established in the process of strain—*i.e.* 'second wind' has been obtained, the heart is relieved, the vessels of the working part are dilated, and the respiratory embarrassment subsides—no further trouble may ensue if rest occurs in due course, but if the work is greatly increased, or if it continues too long, the chief organ to give out is the heart, which is working at high speed and at higher pressure to supply the greater need of the working parts. The heart begins to display its weakness by failing to contract completely, the right heart over-loaded begins to show its distress in the laboured breathing of the lungs. The working parts, making the same demand for oxygenated blood, fail to be adequately supplied, owing to the growing weakness of the heart, and the fatigue products beginning to accumulate interfere therefore with the efficiency of the muscles.

The discomfort under ordinary conditions may become so acute as to make a worker cease his work; the initiative, however, which drives the soldier on, may so obsess his mind as to render him insensitive to these flags of distress and so he continues to the danger-point. The heart, still labouring on, fails, owing to congestion of the right heart, to get itself supplied with oxygenated blood, and the condition is therefore aggravated and it undergoes dilatation. At this stage a failure of cerebral supply brings about syncope, the restitution of cerebral function with the horizontal position may even fail to bring back the mental stimulus, but usually only brings into consciousness the acute feeling of helplessness in the body.

The soldier may then be fortunate enough to be carried straight away.

to the field hospital or even to the base, where apparently complete recuperation takes place, and he may once more take his place in the fighting line.

This is the case usually which, through insufficient rest at the base, may return again suffering in the same way but more severely, and he may be eventually considered unfit to return.

These are the cases that provoke attention; but the cases which are more important to consider from the point of view of military values is the great class of combatants which do not collapse in the field but yet betray to some extent the symptoms of these graver cases. They manage to come through without collapse, but they too display extreme pallor, their blood pressure is extremely low, their heart feeble, and they also exhibit an extreme and incessant restlessness of the hands and feet—*faiblesse irritable*. In this condition they are practically useless as a fighting unit, and are in fact a genuine encumbrance. Fatigue here again has gone slightly beyond the possibility of sound physiological recuperation, and the tissues show depreciation by the celerity with which fatigue is induced on the next occasion for great physical strain. It becomes then a matter of the greatest urgency to see these soldiers are replaced before this excessive fatigue is established; that of course can only be done empirically by a knowledge of the endurance of the soldier in the present type of warfare. It is essential that these soldiers return to the fighting line with their capacity for work undiminished, and it is with this object in view that the hours in the fighting line have lately been limited and the period of rest increased.

Finally the result we have to expect if the demand for adequate rest and recuperation is not satisfied is that a permanent lesion is established.

From this last type of case we perhaps ought to exclude those cases which after great exposure and great strain betray or develop on the one hand tubercular trouble, on the other those cases which, through inherent heart-weakness, develop dilated hearts and incompetent heart-valves. The cases which are especially instructive are those cases which show no other lesion than the arterial.

It was extraordinary to observe how many Serbian soldiers, who have lived through the Balkan wars culminating in this present war, revealed *arterio sclerosis*. Their temporal vessels were always markedly tortuous, and, on examination, almost all palpable vessels were found to be thickened and tortuous.

There seems no better illustration of the result of hard work on arteries than this continued war strain. Hard work has long been stated to be an alternative to the acute specific toxins in the productions of fibrosis in arteries, but has never received much attention.

It was in almost all the above cases possible to exclude the mineral poisons, alcohol, and specific toxins, and by exclusion the only conclusion which could be arrived at was that accumulative fatigue bodies themselves act as an arterial toxin. Moreover, it is necessary to remember the great demands made upon the vasomotor system, which is constantly in requisition in hard work, and therefore constantly

demanding oxygen. With the tax made upon the heart in extreme stress the heart may fail to remove the fatigue bodies, which, accumulating, may irritate the delicate muscular mechanism in the arterial walls. This irritation, with the relative absence of anabolic bodies and oxygen, results in a degeneration of muscular tissue, and the artery in self-defence undergoes fibrous degeneration.

The history of six years of Balkan wars prove beyond dispute that the strain of forced marching, inadequate food, insufficient rest and sleep, resulting in a temporary and functional fatigue to begin with, may ultimately, through a gradual depreciation of tissue, cause a genuine degenerative lesion.

## SECTION II.

### *The Daily Course of Fatigue in Type-setting.*

The Committee have succeeded in securing<sup>1</sup> an hourly output curve of the process of type-setting. Type-setting, whether by machine or hand, is work requiring the closest attention and must be sharply distinguished from the uniform and regular work that can so easily be performed automatically. The reading of the manuscript and the setting of the different combinations of letters and points require judgment and care. Working by hand, there is in addition the task of taking the type from the right box in the compositor's tray and of placing the type correctly on the stick. The piece-hands also often made their own corrections. Work on a typograph machine is much like that of typewriting. The matter to be set was of a uniform nature throughout.

The factory was situated in the country and built spaciouly; there were no special conditions likely to be unfavourable to health.

*Type-setting by Typograph Machines. Operated by men. Average number of 'ens' over period of ten full working days in February 1916.*

—	Chester	Marshall	Newman	Stringer	Average
8-9	3,180	4,880	3,440	2,030	3,382
9-10(a)	3,740	5,730	4,000	2,520	3,997(a)
10-11	3,530	5,320	3,650	2,450	3,737
11-12	3,300	5,520	3,300	2,740	3,715
Dinner Interval.					
1-2	3,570	5,550	3,500	2,800	3,855
2-3 (b)	3,750	5,750	3,780	2,530	3,952
3.15-4.15	4,000	5,840	3,400	2,560	3,950
4.15-5.15	3,780	4,980	2,780	2,120	3,415

*Note.*—(a) There is a mid-spell break of ten minutes from 9 to 9.10. The output for the period 9 to 10 is averaged up to the full hour. (b) There is no break in the work from 3 to 3.15.

<sup>1</sup> By courtesy of Mr. Stanley Unwin, of Messrs. Allen & Unwin, and of Messrs. Unwin Brothers.



Type-setting by hand.—'Piece-hands.' Average number of 'ens' over period of ten full working days (February 1916).

—	Miss Randall	Miss Howells	Bickerton	Smith	Fletcher	Average
8-9	1,420	1,430	1,290	1,140	1,500	1,356
9-10(a)	1,730	1,380	1,430	1,280	1,090	1,383(a)
10-11	1,620	1,530	1,190	1,150	1,110	1,320
11-12	1,640	1,430	1,170	0,900	1,140	1,256
Dinner Interval.						
1-2	1,500	1,300	1,060	1,050	1,330	1,248
2-3	1,550	1,580	1,170	1,100	1,330	1,346
3.15-4.15(b)	1,440	1,750	1,340	940	1,500	1,394(b)
4.15-5.15	1,370	1,300	1,120	860	1,290	1,188

Notes.—There are two mid-spell breaks of ten minutes :—

(a) From 9 to 9.10.

(b) Round 3.30, when tea is taken. For the periods 9 to 10 and 3.15 to 4.15 the output is averaged up to the full hour. There is no break in the work from 3 to 3.15.

The average curve of the output for all the individuals engaged on these type-setting processes follows very closely the curves which were given last year for soldering and labelling tins, and which were then suggested as the normal curve for all work requiring concentration and attention.

Here again the two spells show a similar level of output and a similar curve. On the machines the afternoon output is 2 per cent. higher, in the hand-work it is 2 per cent. lower than the morning output. In both spells, with one exception, the output is at a maximum in the second hour and falls off in the third and fourth. In the afternoon the fall in the fourth hour of the spell (and the last of the day) is particularly marked. The one exception to the rule of a maximum in the second hour occurs in the afternoon spell of the type-setting by hand, when the maximum is in the third hour (from 3.15 to 4.15).

If we may venture on an explanation of the above facts, the usual rise in output between the first and second hours of a spell would seem to be due to the worker getting practised, the fall occurring after the second hour to be due to fatigue. As for the exception in the time of the maximum output, the explanation probably lies in the cup of tea and the break of ten minutes given to the piece-hands at 3.30. The effect of the similar break at 9 A.M. in the case of machine operators as well as piece-hands no doubt adds its weight to that of practice in producing the morning maximum in the 9 to 10 hour.

The above table also records the average output of each individual separately. As might be expected in industry where so many different factors contribute to the result, individuals show some wide deviations from the average curve of output for the day.<sup>3</sup>

<sup>3</sup> The extent of these deviations from the curve can only be measured clearly if the hourly output of each individual be expressed as a percentage of his average hourly rate. Otherwise individual deviations in the level of output will interfere and affect the deviation.

However, in the type-setting by hand, Bickerton represents the average direction of curve in both spells, while Smith does so in the morning spell and Howells and Fletcher in the afternoon. Five spells out of ten are therefore roughly typical. In the type-setting by machine, Chester represents the average direction of curve in both spells, while Newman does so in the morning and Marshall in the afternoon. Four spells out of eight are therefore roughly typical.

No distinctive characteristic seems common to the two women piece-hands, Randall and Howells.

### SECTION III.

#### *Fatigue as a Cause of Accidents.—Introduction.*

In the Interim Report published last year (1915), Section III., page 17, an attempt was made to estimate how far the number of accidents in each working hour could be expected to vary with fatigue. It was there submitted that 'in the causation of many accidents the psycho-physiological state of the victim was probably one of the elements, though generally only as a condition enabling some mechanical cause to take effect,' and further, that fatigue, the most important of psycho-physiological states, would be evidenced by an increase of such accidents towards the end of the working period.

In testing the degree of fatigue by means of the accident curve, the question, therefore, becomes important how far the mental or bodily state of the injured men contributes to the occurrence of industrial accidents. As an experiment a list was made from the particulars of the causes of accidents presented by the Federation of Master Cotton Spinners' Associations to the Departmental Committee on Accidents 1911 (Cd 5540), and in answer to the above question causes were separated according to whether they indicated the state of body and mind and hence fatigue to be contributable to the accident or not; the term 'contributable' being applied to any factor that might possibly be said to have contributed towards the accident.

This list, which found only 75 out of 1,362 accidents to which fatigue was not 'contributable,' has been so often quoted since the publication of the Report (notably in the Brief prepared by Louis Brandeis in defence of the Oregon Ten-hour Working Day) that a more detailed study of the subject seems desirable.

In particular it appears important that the possible contribution to an accident of the injured man's state of mind and body be measured more accurately; in fact, that the possibility of such contribution be 'graded' according to whether it was very great, great, fair, and so on. As will be seen below, in the classification of accidents at the munition factory seven such grades are distinguished.

The usefulness of such a measurement of the degree of contribution to an accident by the victim himself lies mainly in the chance it offers of a more accurate test of the influence of fatigue. In plotting the time-distribution of accidents, only those types of accidents should now be chosen that are attributable in great measure to the victim himself. If fatigue is the main determinant, then in these classes the increase in

accidents as the day proceeds is likely to be steeper than it is for all types of accident taken together. The matter can be brought to the proof.

### *The Victim's Degree of Responsibility.*<sup>3</sup>

An accident is by derivation an injury that was not premeditated. A wound from a mortal enemy's bullet is not an accident, but a casualty or murder, according to circumstance. It is only when injuries occur in industry, where the main purpose is the making of goods, or in any other peaceful pursuit, that they can be called accidents.

Now, this terminology puts us on the track of the most essential characteristic of an accident, the fact that it occurs owing to some unusual circumstance.

Confining ourselves purely to injuries occurring to human beings, it is obvious that such injury<sup>4</sup> is due to some contact of the human body with itself or with a material object, whether solid, fluid, or gas.

The unusual circumstance to which an accident is due must, therefore, occur, either in the movements (or position) of the human body, or in the movements (or position) of some material object, at the time the accident occurred. Where a man injures himself by falling, or places his hand between two cogwheels, or bruises himself against a door-post, it is his body that is behaving unusually; floor, cogwheels, and post are just persisting as usual. Where a load drops on a man, or a tool breaks in his hand, or an explosion blows him up, it is the material, not he, that is acting unusually; or, where a man in the course of his work steps on a plank with a nail in it which enters his foot, it is the material that lay, presumably, in an unusual position.

This analysis of the causes of an industrial accident is undertaken in order to disclose the human element, the degree of responsibility of the injured man at the time; to say that some object acted unusually is, therefore, insufficient. The question must be raised as to what force, human or natural, caused the unusual action. In shell factories the most frequent cause of accidents is the dropping of a shell on to one's own foot; here it was the object that made an unusual movement, but the man who was the motive force. On the other hand, the action of a material object may be due to a fellow workman, or (though the distinction is irrelevant to the injured man's responsibility) where shells fall off a table, or sparks fly out of a wheel, action may be caused by purely natural and mechanical causes.

Where it was the body of the injured man that made an unusual movement, or was in an unusual position at the time, rather than any material object, this may have been caused by something unusual in the external circumstances beyond the man's control. A man may have fallen down a hole because the floor was more slippery than he was accustomed to find it, or he may have tripped up over an object not usually placed in that position; or, again, he may have taken a

<sup>3</sup> Based upon research undertaken by Mr. P. S. Florence under a grant from the Medical Research Committee (National Health Insurance).

<sup>4</sup> Injury is not taken to cover cases of poisoning, strain, sprain, or fainting.

'header' into his machine because the tool on which he was putting his weight slipped.

This last case is, however, somewhat complicated, and is illustrated by several of the examples given below. The exact stages in the occurrence would usually be somewhat as follows:—

1. The man applies too much pressure.
2. The tool slips and thus removes all support from the man.
3. The man falls into, or part of his body moves into, a dangerous spot.
4. The machine inflicts an injury.

Here Stage 4 is due to the usual action of the machine, but the other stages are all unusual.

This case might be classified separately as 'unusual position of the injured man due to unusual action of material due in turn to unusual action of the injured man at the time,' but to avoid a profusion of classes the Stages 1 and 2 may be considered as cancelling out, and therefore forming an absence of, external circumstances beyond the injured man's control at the time. If the tool slipped, not because of excessive human pressure, but because it had become worn or was otherwise defective, then, of course, such external circumstance would be present.

The analysis has now proceeded far enough to show what is the influence of the human element in each class of accident. The human factor, with its liability to recklessness, to inattention and to insufficient muscular co-ordination, obviously preponderates wherever, amid usual conditions, it was an action or position of the human body that was unusual at the time, or else wherever an unusual movement or position of a material object was caused by a human being at the time.

But even in one of the classes of causes of accident that remain, namely, where the dangerous movement of the material object was due to natural causes, the fact that an accident ensued in some cases depends on a human element. Suppose that in hoisting a load on a crane the load swings over and hits a man on the head,<sup>5</sup> he might have avoided it. What chance of escape such a man actually has, depends firstly on whether the hoisting was part of his own work to which he should have been attending, and, secondly, what length of warning the unusual move of the material would give. If the material object fell noiselessly from a height, and to watch it was not part of the injured man's work, then no human element was present in the causation of the accident whatever. A human element would, however, be introduced if the man had been inattentive, or else attentive but slow in escape.

It is now possible to place in order each class of causes of accidents that has been formed, according to the degree to which the human element enters into them. First would come the accidents due to the action of the material which no human capacity could have foreseen or avoided at the time; secondly, accidents which a high degree of attention might just have foreseen; thirdly, accidents which a quick reaction (*i.e.*, presence of mind) might have escaped; fourthly, accidents which

<sup>5</sup> See example D below.

either great attention to the work in hand might just have foreseen and a quick reaction might just have escaped; next, accidents due to some positive inattention or lack of muscular control (usually a muscular inaccuracy) either with extenuating circumstances (fifthly) or not (sixthly); and, finally, accidents due either to a lack of muscular control (often a lack of muscular co-ordination) or to inattention *plus* a slow reaction that misses the chance of escape.

After the enumeration of each class of causes, accidents caused lately under such classes at a large munition factory will be given, being typical or specially complicated examples, as described by the foreman in his report to the head office. It will be noted that the wording often omits one stage in the 'modus operandi' or else is somewhat ambiguous, the tendency being to attribute accidents to an unusual behaviour in the material rather than in the man. Thus a ladle 'coming away' when being handled by the operative is rather like the frequently attested cup-breaking in the housemaid's hands, while to say that 'working at a steam hammer, tongs flew off job,' does not tell us how exactly the hammer affected the tongs. Where necessary, I have appended the explanation of the accident supervisor.

#### *Examples of the Causation of Accidents.*

1st. Unusual action of material objects at the time. Outside scope of injured man's work, no escape possible.

A. 'By valve flying out and catching him on the head.'

B. 'Carrying shell and passing machine a turning flew and burnt eye.'

2nd. Unusual action or position of material objects at the time, within scope of injured man's work, no escape possible.

Includes all injuries from sparks or cuttings flying out of work in hand.

3rd. Unusual action or position of material objects at the time, outside scope of injured man's work, escape possible.

C. 'Shell rolled off a bench and fell on his foot.'

Includes most injuries from fellow workers' carelessness.

4th. Unusual action or position of material objects at the time, within scope of injured man's work, escape possible.

D. 'While slinging job with crane, the job slung round and caught him on leg.'

E. 'While setting the bar, the machine started, and his hand was caught between the bar and the shell-carrier.'

F. 'While throwing water on scar from furnace, steam scalded his arm.'

G. 'While walking across the shop, stepped on to a piece of wood with a nail in it. The nail penetrated his boot, and entered his foot.'

5th. Unusual action or position of injured man at the time attributable to unusual circumstances beyond his control.

H. 'While removing a 12-inch punching-die off press, he stepped back to keep clear and in doing so fell over a 12-inch shell-block which was lying behind him.'

I. 'Slipped on piece of sheet-iron and wrenched his back, when lifting 4.5 forging.'

6th. Unusual action or position of injured man at the time not attributable to unusual circumstances beyond his control. Consists

mainly of injuries from falls, and also from catching in the machine, as follows:—

- J. 'While reaching over to stop the machine, his sleeve was caught by the drill.'
- K. 'While fastening shell in chuck, elbow caught reamer and caused the machine to be in motion.'
- L. 'In pushing G. M. ring in lathe to fix it with the dogs, his hand slipped off edge which had just been faced and was cut, making a very nasty wound.'
- M. 'While filing work in machine, finger came in contact with a rough edge of job and was lacerated.'
- N. 'In lifting the ladle from the boiling resin, the ladle, which had stuck, came away suddenly and splashed the boiling resin over hand and a little on face.'
- O. 'While standing waiting for turn at steam forging hammer, a job which was being forged got fastened in tool, and as he was in the act of knocking it out it jumped out and fell on his foot.'
- P. 'Wooden stick which is used for cleaning shell slipped, and hand caught on shell, cutting it on the back.'
- Q. 'Cleaning machine while running slow, belt pulled in waste, also three fingers.'

7th. Unusual action or position of material due to the injured man at the time.

- R. 'In throwing shunting stick on back of engine after coupling waggons, the hook of stick caught him on wrist.'
- S. 'While gauging a shell it slipped and fell on his right foot.'
- T. 'Filing rag off edge of hole, the file caught the slot in chuck and jammed hand on tool.'
- U. 'Grinding chisel, which slipped and cut palm of left hand.'
- V. 'While working at steam hammer, tongs flew off job with the force of bat striking him in the face.'

*Note to V.*—The man in all probability had been holding the tongs at an unusually high angle.

#### SECTION IV.

##### *The Applicability of Psychology to Problems of Industrial Fatigue.*

###### *(a) Laboratory Experiment.*

One of the most important general differences between laboratory experiments and the normal conditions of the factory is to be found in the difficulty of ensuring any degree of *natural affective behaviour* in any kind of experiments suitable for laboratory investigation. Thus the very important factor constituted by the subject's every-day interests is not likely to show in the laboratory even where instructions are given to 'behave naturally.' The chief 'interest' which the subject is likely to feel is a certain curiosity as to the results of the experiment itself—a state of mind which has no precise parallel in the industrial field.

Moreover, the conditions of experimentation imply a very high average degree of tension, and of concentration on the operation or reaction of the moment, with no reference to the affective side of the personality taken as a whole. In the factory, on the other hand, the worker spends the greater part of his life; on his work the continuation of his existence largely depends. Boredom or joy in work may here exercise a peculiar influence on output—not less than economic considerations based on desires of the most far-reaching character.

Hence in experimental work the immediate conditions of attention are chiefly of an objective nature, such as the intensity, extent, and duration of the stimulus; in the factory, attention is more frequently determined by the mental relation of the worker to his work, by his needs and desires, by his moods and by his 'interests.'

On the other hand, laboratory work is able to study certain factors in isolation in a manner which the complicated conditions of factory and school life render impossible; and the problem with which we are concerned is to discover how far factory investigation can profit by the analysis of the experimenter, and how far the artificiality of laboratory conditions is detrimental to the transference of conclusions from one field to another.

First of all, we are confronted by the general problem which arises when we bear in mind the sudden accessions of *energy* of which every-day life shows so many examples, but which only occur on a small scale under artificial conditions:—

'It is the possibility of these sudden accessions of energy,' says Dr. McDougall, 'that has rendered well nigh futile all the many attempts hitherto made to obtain reliable objective measures of degrees of fatigue of the organism as a whole.' He refers to the recent work of Dr. Rivers, which shows how even in ergographic work suggestion and expectation are often distinctly disturbing factors and essentially involve the bringing into play of one or more of these special sources of energy.

Physiologists in particular are accused of neglecting this general consideration. 'It seems impossible to get the physiologists of the laboratory, the physiologists who are chiefly concerned with the organs rather than with the organism, to consider this conception seriously and on its merits. If they occasionally refer to it, it is only to put it aside contemptuously as a naïve survival from the dark ages. Yet those who are in the habit of dealing with the problems of the organism as a whole, the physician and the psychologists, constantly make use of this conception, for they find it impossible to make progress in the understanding of their problems without it. That fact gives the conception a claim to a more serious consideration than it has commonly received from the physiologists.'

But it is not only in their neglect of such general conceptions of every-day life as energy that the psychologists of the laboratory are in need of correction. They are too apt to work under conditions which in the case of fatigue practically *exclude the production of any true fatigue as we meet with it in industry*. And it is therefore not surprising to note with regard to the general question of method, that MM. Binet and Henri have shown the inadequacy of the various methods supposed to estimate the fatigue of the organism *as a whole* employed previous to the date of publication of their work 'La Fatigue Intellectuelle' (1898); and in a recent critical study of the principal methods Messrs. Ellis and Shipe<sup>6</sup> have arrived at the conclusion that none of those investigated by them are reliable.

<sup>6</sup> *American Journal of Psychology*.

Nevertheless, a good deal has been achieved in spite of the absence of universally accepted criteria, and in his 'Manual of Mental and Physical Tests' Professor G. M. Whipple, of Cornell, has given a useful account of some of the leading methods employed so recently as 1910 with sundry references to fatigue.

The study of these methods is a good index of the difference between laboratory and industrial work.

First in importance comes the Ergograph, which records the *endurance* of a group of muscles, and is also used as an index of the effect of all forms of work. The ergograph, though objections have been raised to it on the ground that it fails properly to isolate a single muscle, is very much more confined in its fatiguing effects than any industrial process.

The tapping test secures an index of various forms of *motor ability*, speed, &c., and also of the fatigue effects of rapid movements. It is even further removed from the operations of industry than is the ergograph.

With the claims of the æsthesiometer as a direct index of fatigue we have dealt in connection with school experiments. Of the various methods of producing and testing mental fatigue, which include cancellation (the crossing out of assigned letters or words from a printed sheet), completion (Ebbinghaus's test mentioned below under (b)), tests of memory, computation and simultaneous operations, only the two last call for special remarks here.

Almost all analyses of the work-curve have been based on experiments in computation, and the same is true of pauses. Computation in its various forms is assumed to imply perception, movement, attention and retention, as well as associative activity; and Kraepelin and his followers have confined themselves chiefly to addition. In order to produce greater fatigue Thorndike has used four- and five-place numbers both for addition and multiplication. It need hardly be remarked that the kind of fatigue produced by work of this sort is reliable chiefly for certain problems of refined analysis. It is obviously peculiar, and largely temporary in its effects, and is considerably complicated by the elements of boredom and practice, to say nothing of mental types.

Similarly, the experiments hitherto conducted on simultaneous activities have only a remote connection with the complex operations found in industry. Binet has suggested various methods of testing ability to execute concurrent motor activities, but most of the work has been done on purely intellectual operations.

One of the most recent and successful pieces of laboratory apparatus is that devised by Dr. W. McDougall<sup>7</sup> and described by him in the 'British Journal of Psychology,' 1904-5. The process has more in

<sup>7</sup> Dr. McDougall has written as follows (B.A. Report, 1908, p. 487) of the further utility of his apparatus: 'The Kraepelin methods seek to avoid disturbances by keeping interest at a minimum. But the human subject is not easily kept in such a state; he will become interested if only in the approaching end of his task, and hence great irregularities. In view of these difficulties I have suggested a method of estimating fatigue, which follows the opposite principle, and seeks to keep interest at a maximum throughout, the task set being of the nature of a sprint.'



common with many processes of industry than any ergographic or mental test, and consists essentially in successfully jabbing with a pen at a series of spots in irregular succession on a cylinder. The rate of rotation may be increased or decreased, and the subject may be given any other task to be performed concurrently. It is claimed that the method enables us to measure, after an interval of half-an-hour's duration, the degree of fatigue produced by an effort sustained for about three minutes only.

This method is not dissimilar from the operations involved, *e.g.* in working on the dial-feed cartridge-making machine, and when its value has been more generally recognised, it should provide a more practical measure of the effects both of monotonous and complex operations, and of the value of pauses, than has hitherto been available.

A question naturally arises as to the value for industrial purposes of experimental work which does not reproduce the actual processes and machinery of the factory itself. On the one hand, we have the very natural objection that any abstraction from the actual conditions must, to some extent, vitiate the applicability of the results obtained. On the other hand, Muensterberg has pointed out that unless concrete situations are reproduced *in toto* we can never be sure that the omission is not an essential factor. He illustrates the argument by the contention that a reduced copy of an external apparatus may arouse ideas, feelings, and volitions which have little in common with the processes of actual life. The man to be tested for any industrial achievement would have to think himself into the miniature situation, and especially uneducated persons are often very unsuccessful in such efforts. This can clearly be seen from the experiences before naval courts, where it is usual to demonstrate collisions of ships by small ship models on the table in the court-room. Experience has frequently shown that helmsmen, who have found their course all life long among real ships in the harbour and on the sea, become entirely confused when they are to demonstrate by the models the relative positions of the ships.

Hence Muensterberg urges the necessity of concentrating on the essentials of the process involved; *e.g.* in the case of street-car accidents a peculiar strain on the attention, &c.

It is obvious that such a selection of essentials may be of the greatest value for the study of fatigue in certain cases—especially where attention is involved. On the other hand, there are many other kinds of operations which are simple enough to reproduce *in toto*, and which can be better studied under laboratory conditions than in the factory itself. Particular interest attaches to the controlled experiments of Bogardus designed to get a degree of monotony and speed and strain equivalent to that produced by a longer spell of similar operations in the factory; and showing that two-thirds of the muscular inaccuracies occurred in the last half of the period.

### (b) *Educational Psychology.*

Scepticism with regard to the possibility of obtaining any satisfactory conclusions as to the effect of fatigue in schools seems to have

given place quite recently to a more hopeful attitude, chiefly as a result of various studies by Winch, in which definite results are claimed as the result of a strictly scientific procedure.

It is possible, therefore, that interest in the relations of fatigue in industry and education will now revive; but there are many important respects in which the conditions of school and factory respectively affect the study of fatigue. First of all, there is the general consideration that according to many modern educationists any conception of the school which approximates educational to industrial conditions is in itself a gross abuse. The object of the school should be to avoid all that leads to premature fatigue, and it is therefore only in ill-managed undesirable cases that we can casually step into the school in the expectation of finding measurable fatigue.\*

Even where modern conditions still allow of fatigue it must be regarded very differently from the fatigue of the factory. In *The Great Society* Graham Wallas writes: 'The stimulation of our nervous system along any given line of discharge makes a further stimulation along the same line more easy. It also "uses up" something in the nervous structure which requires time to repair. Every teacher knows that if a boy has to spend two hours in doing a succession of elementary sums of the same kind, he will do them with growing ease *qua* habit and growing difficulty *qua* fatigue. After a period of rest the fatigue wears off and the habit remains, so that a boy may then prove to have been making most progress towards accuracy in sum-working when he was too tired to work his sum accurately.'

This fatigue in the process of learning, this conception of progress cannot easily be paralleled in the factory. Extra effort is never stimulated in the factory with a view to the formation of habit! The majority of mental tests as employed on school children are the same as those of the laboratory, and have not been essentially modified in the past sixteen years. Leuba's remarks of 1899 still hold good:—

'The mental test,' he then wrote, 'has been extensively applied. It is Kraepelin's method and the method of Burgerstein, Haser, Kemsies, and many others. The form may vary widely; firstly, in the character of the work required, which may be either a long series of simple examples (*v.* Laser, Holmes, Richter), or a few pieces of more difficult work (*v.* Sikorsky, Friedrich, Kemsies); and secondly, in the method of measuring fatigue, which may be either by the decrease in the rapidity with which the work is done or by the increase in the number of errors which occur. A test which has been called the "combination method" was devised by Ebbinghaus, who used paragraphs of text from which here and there words had been erased. The subjects were required to fill in all the blanks, within a given time, with words which made sense with the context. Measurement was by the number of errors occurring.

'The apparatus for all such mental tests is simple; it requires only the preparation of a set of arithmetical problems or the mutilating of

\* On the other hand, over-pressure will show itself in its pernicious effects on health in general and in the production of nervous or bovine dispositions. See *e.g.* Hertel's *Over-pressure*, p. 33.

a printed page. Its method of reading results is likewise easy, since it consists in a mere counting and averaging of errors. The truth of its interpretation is, however, by no means so certain. The test does not get at the phenomenon to be studied at all directly or unequivocally, unless the distinction between fatigue and weariness is to be overlooked altogether. The material from which the results are read is the product of the total set of mental conditions obtaining at the time of the investigation, and the number of errors in any given case will as readily be affected by a feeling of rivalry between the pupils or by a momentary distraction as by the influence of fatigue itself. These influences cannot unconditionally be set down as constant factors, which are, therefore, eliminable. The anticipation of recess or the conclusion of work may very well be potent in establishing a law of rhythmical increase and decrease in the number of errors, which will well combine with the actual exhaustion effects to produce a curve which does not at all truly represent the rise in fatigue. The results of practice, likewise, interfere with the purity of the fatigue curve when it is determined by the numbers of errors occurring.'

As Weber has pointed out, Kraepelin himself was very cautious in his attitude to the subject; but other investigations at the end of the last century raised the hopes of educationists and produced those strange obsessions as to the value of the æsthesiometer, which occupied so much space in psychological literature for a number of years.

R. MacDougall summarises the scale of values and recommendations which these æsthesiometric investigations endeavoured to establish, as follows:—

'Mathematics and classics stand high in all the lists; singing, drawing, and religion come far down, as does also the study of German. That is, studies which demand close application tax the pupil heavily, while those in which practice and mechanical routine can play a part are marked by slight fatigue. Gymnastic exercise, instead of being recuperative, ranks among the most fatiguing forms of school work. Only light exercise is recreation. Even the recess period is marked by deep fatigue in those who indulge in violent exercise. Instead of the customary intervention, the various investigators agree in recommending a shorter pause after each hour's work, during which noisy games shall be discouraged and the children taught to seek rest, fresh air, and gentle movement. In these lies the solution of the problem of fatigue in school.'

It is clear that many of these views would be supported by educational reformers on grounds of common experience, but it has been demonstrated by Leuba, Germann, and others that the æsthesiometric method is quite inadequate to establish such far-reaching conclusions.

### (c) *The Need for Co-operation.*

On the whole, however, in spite of their experiments in school and laboratory, the work of psychologists is still for the most part the reverse of illuminating for the problems of industry. The writers of

general text-books are content to introduce fatigue in the most cursory manner, and the student can obtain from them little idea of the problems which now demand attention.<sup>9</sup> Dr. Myers, in Chapter xiv. of his 'Text-book of Experimental Psychology,' Vol. I., has recently made a welcome step in the right direction.

The results of industrial investigation have now clearly indicated

\* It is worth while to present a brief analysis of the way in which even such an authority as Kuelpe introduces Fatigue into his well-known *Outlines of Psychology*. After defining a sensation as a simple conscious process standing in a relation of dependency to particular nervous organs, he states that sensations are compared by means of 'sensible discrimination,' and are experienced and communicated by 'sensitivity' which may be either direct or indirect (pp. 31 and 33). Sensible discrimination and sensitivity are improved amongst other things by a greater degree of attention and expectation: habituation facilitates attention and expectation, but too great habituation nullifies their effects and dulls the subject's interest in the experiment.

Practice in a process increases delicacy of perception and readiness of judgment by increasing attentional concentration and capacity of reproduction. Fatigue decreases all these things. Both practice and fatigue may be general or special (p. 43).

Peripherally excited sensations (p. 87) are of various kinds—cutaneous, tactile, olfactory, visual, and organic. There are also 'common sensations' in which one or more of these are compounded; and there is the sensation of giddiness which may be the function of a particular sense organ, the static sense. The common sensations include hunger and thirst, tickling, itching, and shivering; cardiac and respiratory sensations, the sensation of being 'all right,' and finally the sensations of exertion and fatigue (pp. 146-148).

Centrally excited sensations, all of which have previously been peripherally excited, are reproduced (through the mediation of direct or indirect recognition and association) modified in various degrees in memory and in imagination. This reproduction, like sensitivity and sensible discrimination, is conditioned by attention, by practice, and by fatigue, general and special. Relaxation after a sleepless night weakens memory in all departments. Persistent occupation with a particular object fatigues the memory. Kuelpe (p. 212) regards it as uncertain whether fatigue influences associability and reproductivity directly, or only indirectly—i.e. by way of attention. The abnormal increase of central excitability at a certain stage of fatigue (evidenced by vivid dreams, multiplication of illusions, &c.) seems to indicate that the diminution of associability and reproductivity resulting from fatigue does not affect the central sensations themselves so much as the arrangement, connection, and direction which are normal to them under the guidance of voluntary attention. An analysis of the influence of practice leads to a similar conclusion. We must therefore suspend judgment upon the question whether practice and fatigue are conditions of centrally excited sensations co-ordinate with attention. The forgetfulness of old age is probably to be explained by reference to fatigue (p. 217).

Affective states, the pleasantness and unpleasantness of a sensation, are adversely influenced by fatigue, which (p. 261) weakens what would otherwise be a pleasure, and increases what would normally be a moderate unpleasantness.

Fatigue is apt to retard the work of auditory analysis (p. 303). It is far more difficult to distinguish the individual tones in a clang or to reduce a compound clang to its simpler constituents when the mind is fatigued than when it is fresh. The effect of fatigue, therefore, seems to be restricted to the increase of fusion degree, to the reinforcement of the unitariness of the total impression. Fatigue also diminishes the accuracy of estimating time intervals, brightness contrast, and:

Fatigue lengthens reaction time in experiments.

Though there is a relation between fatigue and sleep, sleep can hardly be regarded as a special instance of the general phenomenon of fatigue, as it is often impossible under circumstances of extreme exhaustion. A theory

several directions in which further assistance from psychologists is urgently needed.

A. The effect of the following factors in predisposing or retarding the onset of Fatigue:—

I. The *Intelligibility* of the work. What types of workers, if any, can take more pleasure in their work when each action has its place in some definite whole whose purpose they can understand. Are Kerschesteiner's conclusions on this subject ('The Schools and the Nation,' p. 121, &c.) valid also for Industry?

II. *Spurt*, on account of rush orders, &c. The investigations of Kraepelin require more detailed examination in their application to the factory.

III. *Rhythmisation*.—Since industrial operations are usually complex—*i.e.* consist of several co-ordinated movements—rhythm requires further analysis into two elements:—

(a) Regularising of the time of the whole complex operation.

(b) Regularising of the method of operation—*i.e.* the timing of the separate movements within the whole operation.

How far is there an adaptation of work rhythm to some natural (physiological) rhythm?

IV. *Concentration and attention* over long periods. How exactly is Attention affected by Fatigue, *e.g.* at the end of a long spell of work (four or five hours)? What explanations can be given of the rise in accidents near the end of such a spell? Is it a case of momentary lapses or a general failure in intensity of application? Why does the number of accidents fall again in the very last hour of the spell before the meal-breaks? (See 1915 Report.)

B. What apparatus now at the service of Experimental Psychologists is most suitable for use in factory investigations? What further contrivances can be devised to facilitate such research?

of sleep must therefore include a reference to the attention, the importance of which for its induction or prevention is well known. There is no surer means of producing sleep than to tire the attention.

Kuelpe's standpoint throughout is that of the laboratory experimenter. His references to fatigue are either designed to put the experimenter on his guard against influences disturbing normal conditions, or are of the nature of *obiter dicta*.

## SECTION V.

*Bibliography.*

The classification adopted for the Subject Bibliography is as follows :

A. *Non-Industrial.*

- I. (a) General.
- (b) Attention, Interest, Suggestion.
- II. Mental Work.
- III. Physical Aspects.
  - (a) General.
  - (b) The Senses (ocular, auditive, tactile, olfactory).
  - (c) Muscles.
  - (d) Nerves.
  - (e) Brain.
  - (f) Circulation and Respiration.
  - (g) Chemical analysis.
  - (h) Temperature.
  - (i) Food ; Drugs ; Alcohol.
  - (j) Athletics.
  - (k) Typewriting.
  - (l) Reaction.
- IV. Apparatus and Method.
  - (a) General.
  - (b) Ergography.
  - (c) Æsthesiometry.
- V. Practice.
- VI. Rhythm.
- VII. Pauses.
- VIII. Hygiene. Sleep.
- IX. Educational.
- X. Abnormal.
- XI. Supplementary and Various.

B. *With special reference to Industry.*

Entries grouped under Section B (Industrial) were for the most part printed in the Index of Sources at the end of our 1915 Report. The following selections comprising the group '1 (a) General' in the above classification give an idea of the scope of the work, and include only those entries which do not fall under any of the special groups into which it has been found convenient to divide the whole.

- AMAR, J. . . . . Effets physiologiques du travail et 'degré de fatigue.' 'C.R. Acad. d. Sci.,' CLVII. 646-649. 1913.  
 A useful paper which confines itself to a discussion of the phenomena of circulation and respiration in connection with various kinds of work, and shows when the conditions of work are no longer normal by a series of experiments upon rhythm and arterial pressure.
- . . . . . Observations sur la fatigue professionnelle. 'J. de Physiol. et Path. Gén.' XVI. 178-188; 192-202. 1914.
- BAUR, A. . . . . Die Grenzen Ermüdung und Uebermüdung. 'Studien Päd.-psychol.' v. 17-19. 1904.
- BETTMANN, S. . . . . Ueber die Beeinflussung einfacher psychischer Vorgänge durch körperliche und geistige Arbeit. 'Psychol. Arb.' 152-208. 1896. Influence of walking or adding on reactions.
- BEVAN-LEWIS, W. . . . . The Neuron Theory: Fatigue, Rest and Sleep. 'Rep. Brit. Ass.' LXXVI. 722-723. 1906. A brief statement.
- BIBROWICZ, W. . . . . See Leubuscher, P.

- BULKLEY, L. D. . . . Fatigue as an element of menace to health in the industries. '39th Annual Meeting of the American Academy of Medicine.' 1914.
- BURNHAM, W. H. . . . The Problem of Fatigue. 'Amer. J. of Psychol.' XIX. 385-399. 1908. A short suggestive enumeration of factors under influence of James.
- CANCELLIERI, D. . . . Della Fatica. 'Riv. ped.' I. 183. 1908.
- CARRIEU, M. . . . De la fatigue et de son influence pathogénique. Paris, pp. 131. 1878.
- DE SANDRO, D. . . . The significance of physical fatigue. 'La Rif. med.', No. 31. 1910.
- DESSY, S., and GRANDIS, V. . Contribution à l'étude de la fatigue. 'Arch. ital. de Biol.' XLI. 225-233. 1904. Criticising and supplementing the work of Abelous, Langlois, and Albanese.
- DRESSLEN, F. B. . . . 'Fatigue.' 'Ped. Sem.' II. No. 1, 102-106. Also 'Amer. Jour. of Psychol.' IV. 514-517. 1892.
- FÉRÉ, C. . . . Etude expérimentale de l'influence des excitations agréables et des excitations désagréables sur le travail. 'Année Psychol.' VII. 82-129. 1901.
- . . . Etudes expérimentales sur le travail chez l'homme et sur quelques conditions qui influent sur sa valeur. 'J. de l'Anat. et de la Physiol.' XXXVII. 1-79. 1901. A brief review of the physiological and psychological conditions which bear upon the performance of work.
- . . . Les variations de l'excitabilité dans la fatigue. 'Année Psychol.' VII. 69-81. 1901.
- . . . Travail et Plaisir. Paris, 1904. Sums up Féré's work to that date. Enterprising and suggestive but rather unreliable.
- . . . L'économie de l'effort et de travail attrayant. 'J. de l'Anat. et de la Physiol.' XLII. 253-292. 1906. An interesting study, with many detailed experiments bearing on the subject in question.
- FISHER, I. . . . Report on National Vitality. 'Yale Univ.' July 1909.
- FLÜGEL, J. C. . . . Some observations on local fatigue in Illusion of Reversible Perspective. 'Brit. J. of Psychol.' VI. 60-77. 1913.
- FOSTER, M. . . . Weariness. 'Nineteenth Century.' Sept. 1893.
- FOURNOL, L. . . . Contribution à l'étude du surmenage. Paris, 1879.
- FRANZ, S. I. . . . Fatigue factors in certain types of occupations. 'Trans. xv. Intern. Cong. of Hygiene,' III. 512-517. 1913. Psychologist to Government Hospital for Insane, Washington.
- GLEY, E. . . . Etudes de Psychologie. Paris, 1903. Correlation of mental work and automatic processes.
- GRANDIS, V. . . . See Dessy, S.
- HARLESS, E. . . . Das Problem der Ermüdung und Erholung. 'Aerztl. Int.-Bl.' 1861. München, VIII. 1.
- HENRI, V. . . . Etude sur le travail psychique et physique. 'Année Psychol.' III. 232-278. 1897. A select bibliography of forty-four items is appended.
- HILL, D. S. . . . Fatigue: Some of its Scientific and Practical Aspects. 'Methodist Qt. Rev.' Pp. 19. Oct. 1909.
- HILLGRUBER, A. . . . Fortlaufende Arbeit und Willensbetätigung. 'Untersuch. zur Psychol. u. Phil. hrsg. v. Ach. N.' I. Bd. 6 H. pp. 50. Leipzig: Quelle and Meyer, 1912.
- HOLLINGWORTH, H. L. . . . Variations in Efficiency during the Working Day. 'Psychol. Rev.' XXI. 473-491. 1914.
- IMBERT, A. . . . Fatigue as a result of occupation. '14th Intern. Cong. of Hyg. and Demography.' Berlin, 1907.

- JOTEYKO, J. . . . . Le quotient de la fatigue H/N. 'C.R. Acad. d. Sci.' cxxx. 667-669. 1900.
- . . . . . Excitabilité et fatigue. 'Rev. de l'Univ. de Brux.' 125-143. 1901.
- . . . . . Le siège de la fatigue. 'Rev. gén. d. Sci.' XIII. 294-300. 1902.
- . . . . . La fatigue. 'Dictionn. de Physiol.' Richet, vi. 185. With bibliography. 1903.
- . . . . . La fatigue. Paris, Alcan, 1902.
- . . . . . Les Défenses Psychiques. 'Rev. Psychol.' xxxviii. 113-134; 262-273. 1913. Review in 'Année Psychol.' p. 381. 1914.
- KIPIANI, V. . . . . Lois de la fatigue. 'Rev. Scient.' 5 S., iv. 367-369; 398-403. 1905. Reviewing some of the work of Joteyko on Ergography.
- KOCHMANN, WILHELM . . . Ueber die Verhältnis von Arbeitszeit und geistiger Aufnahmefähigkeit der Arbeiter. 'Archiv für S.' 873. 1913.
- A prescription of the methods that can be used in establishing how far the worker is really in a position to develop his faculties after accomplishing his day's work; whether he is not obliged to dispense with all recreation that is of cultural value and tends to develop his personality, having to fall back on the public-house, the cinematograph, music-halls, football, and such like. Deals also with changes in the working capacity of the workman outside his professional activity, a province where the automatization of functions cannot enter.
- KRAEPELIN, EMIL . . . . Die Arbeitskurve. 'Philos. Studien.' 459-508. 1902.
- and RIVERS, W. H. R. . . Ueber Ermüdung u. Erholung. 'Psychol. Stud.' 627-678. 1896.
- LADD, G. T., and WOOD-  
WORTH, R. S. . . . . Elements of Physiological Psychology. 'Scribner,' chap. vii. sec. 32-37. 1911.
- LAGRANGE, FERNAND . . . La fatigue et le repos. Pp. 357. Paris, Alcan, 1912. The most comprehensive general study.
- This book contains the most comprehensive general survey of the whole subject. M. Lagrange divides the work into three parts. In the first he discusses the physiological, psychological, and other aspects of fatigue itself. In the second he mentions various therapeutic measures, and in the third he deals very fully with the meaning and value of rest.
- LAHY, J. M. . . . . Les effets comparés sur la pression du sang de la fatigue physique produite par une marche prolongée et de la fatigue psychique résultant d'un travail d'attention. 'C.R. Acad. d. Sci.' clviii. 1913-1916. 1914.
- LEE, F. S. . . . . Fatigue. 'Harvey Lectures.' 1906. See also 'J. of Amer. Med. Assoc.' XLVI. 1491-1500. 1906.
- . . . . The Nature of Fatigue. 'Pop. Sci. Mo.' 1910.
- . . . . The Physiology of Exercise and Rest. 'Journal of Outdoor Life.' June 1911. Lee's three general studies are the clearest and most reliable statements extant.
- LEUBUSCHER, P., and  
BIBROWICZ, W. . . . . Neurasthenie i. Arbeiterkreis. 'Deutsche Med.' May 1905.
- LINDHEIM, A. R. VON . . . The Morbidity and Mortality of Occupations. '14th Intern. Cong. of Hyg. and Demography.' Berlin, 1907.



- LINDLEY, E. H. . . . Ueber Arbeit und Ruhe. Leipzig, 1900. Also 'Psychol. Arb.' v. 3, pp. 491-517. 1901. With many detailed statistics and calculations.
- LORENTZ, F. . . . Die Ermüdung und das Antikenotozin. 'Zs. f. päd. Psychol.' xv. 482-484. 1914.
- MACDOUGALL, R. . . . A Review of Fatigue. 'Psychol. Rev.' vi. 203-208. 1899. Rather favourable summing up of æsthesiometry.
- MCDUGALL, W. . . . Fatigue. 'Rep. Brit. Assoc.' 1906. Very important study; especially conception of energy.
- MANASEINA, M. . . . Le surmenage mental dans la civilisation moderne. Translated from the Russian. Paris, 1890.
- MARSH, H. D. . . . The Diurnal Course of Efficiency. Diss. New York, Science Press, 1906.
- MIESEMER, K. . . . Ueber psychische Wirkungen körperlicher und geistige Arbeit. 'Psychol. Arb.' iv. 375-434. 1902.
- MOORE, J. M. . . . Studies in Fatigue. 'Yale Studies,' v. 3, pp. 68-95. 1895. General conclusion that fatigue makes work less rapid, accurate, and regular.
- MOSSO, ANGELO . . . La Fatica. 1891. English Trans. Drummond. New York, 1904. London, Allen and Unwin, 1914. Remains a mine of suggestive work even to-day.
- OEHREN, AXEL . . . Experimentelle Studien zur Individual Psychologie 'Inang. Dis. Dorpat,' 1889. Yoakum speaks of it as 'beginning' the work of the Kraepelin school.
- OLIVER, Sir T. . . . Occupational Fatigue. 'Journal of State Medicine.' Oct. 1914.
- PALMEN, E. . . . Ueber die Einwirkung verschiedener Variabeln auf die Ermüdung. 'Skand. Arch. f. Physiol.' xxiv. 197-225. 1910.
- PATRICK, C. T. W. . . . The Psychology of Relaxation. 'Pop. Sci. Mo.' LXXXIV. 590-604. 1914.
- POFFENBERGER, A. T., and TALLMAN, G. C. . . . Variability in Performance during Brief Periods of Work. 'Psychol. Rev.' xxii. 371-376. 1915.
- POORE, G. V. . . . On Fatigue. 'Lancet,' ii. 163. 1875.
- REVILLIOD, L. . . . La fatigue. 'Bull. Soc. méd. de la Suisse Rom.' xiv. 250, 279. Lausanne, 1880.
- RITZMANN, F. . . . Arbeit, Ermüdung und Erholung. 'Concordia: Zs. der Zentralstelle für Volkswohlfahrt.' Nov. 1907.
- RIVERS, W. H. R. . . . See KRAEPELIN, E.
- RUDNEV, V. I. . . . Ueber Ermüdung [Russian]. 'Kazanĭ, Med. Žurn.' i. 525-529. 1901.
- SACHNINE, H. . . . Etude sur l'influence de la durée du travail quotidien sur la santé générale de l'adulte. Thèse. Lyon, 1900.
- SAVAGE, J. H. . . . Overwork as a Cause of Insanity. 'Lancet,' ii. 127. 1875.
- LE SAVOUREUX, H. . . . L'ennui normal et l'ennui morbide. 'J. de Psychol. norm. et path.' xi. 131-148. 1914.
- SCHMIDT, A. . . . Uebermüdung. 'Med. Klinik,' ix. 567-568. 1913.
- SCHOENHALS, P. . . . Neurasthenie und Hysterie bei Arbeitern. 'Monats. für Unfallheilkunde,' 289. Aronheim, 1906.
- SCHUYTEN, C. . . . Qu'est-ce que le surmenage? 'Rev. psychol.' i. 142-158. 1908.
- SHAW, E. R. . . . Fatigue. 'Addr. and Proc. Nat. Educ. Assoc.' 550-554. 1898.
- SPECHT, W. . . . Zur Analyse der Arbeitskurve. 'Zs. f. päd. Psychol.' ii. 19-31. 1910.
- STIRLING, W. . . . Health, Fatigue, and Repose. 1913. 'Lady Priestley Lecture,' 1914. Popular account of various modern views.

- STRONG, E. K. . . . . Fatigue, Work and Inhibition. 'Psychol. Bull.' x. 444-450. 1913. Very useful summary of recent work.
- . . . . . Fatigue, Work and Inhibition. 'Psychol. Bull.' xi. 412-417. 1914.
- STUPIN, S. . . . . Beiträge zur Kenntniss der Ermüdung beim Menschen. 'Skand. Arch. f. Physiol.' xii. 149. 1902.
- SUDDUTH, W. X. . . . . Fatigue in its relation to Consciousness. 'Alien. and Neurol.' xxii. 467-474. 1901.
- THORNDIKE, E. L. . . . . The Curve of Work. 'Psychol. Rev.' xix. 165-194. 1912. Vigorous criticism of Kraepelin school.
- . . . . . Fatigue in a Complex Function. 'Psychol. Rev.' xxi. 402-407. 1914.
- TISSÉ, P. . . . . La Fatigue et l'entraînement physique. Paris, 1897. A popular study, with interesting remarks on the results of gymnastics.
- TRÈVES, Z. . . . . Contributo critico-sperimentale allo studio dei fenomeni soggettivi di fatica nel lavoro volontario. 'Riv. di Patol. nerv. e ment.' x. 201-219. 1905.
- VERWORN, M. . . . . Ermüdung und Erholung. 'Berlin Klin. Wochensch.' xxxviii. 125-132. 1901.
- WELLS, F. L. . . . . Fatigue. 'Psychol. Bull.' viii. 390-395. 1911. Incomplete summary of new work in 1910-1911.
- . . . . . Fatigue. 'Psychol. Bull.' ix. 416-420. 1912. Summary of recent work.
- WEYGANDT, W. . . . . Ermüdung und Erschöpfung. 'Sitz. Ber. physik. ges.' 37. Würzburg, 1901.
- WOODWORTH, R. S. . . . . See LADD, C. T.
- WRIGHT, W. R. . . . . Some Effects on Incentives on Work and Fatigue. 'Psychol. Rev.' xiii. 23-24. 1906.  
A series of ergographic experiments are here described, which confirm the great importance of interest. Among other conclusions drawn from the experiments is the fact that the subject accomplished more work when working with a definite aim, and that the fatigue accompanying such work is less than that acquired under no such direct stimulus.
- ZUNTZ, N. . . . . Die Merkmale der Ermüdung. vii. 741-744. Umschau, Frankfurt a. M. 1903.

---

*Industrial Unrest.*—Abstract of the Report of the Committee, consisting of Professor A. W. KIRKALDY (Chairman), Mr. E. J. W. JACKSON (Secretary), the Rt. Hon. CHARLES BOOTH, the Rt. Hon. C. W. BOWERMAN, Sir HUGH BELL, Sir C. W. MACARA, the Ven. Archdeacon CUNNINGHAM, Professors S. J. CHAPMAN, E. C. K. GONNER, W. R. SCOTT, and Messrs. S. BALL, H. GOSLING, HOWARD HEATON, and PICKUP HOLDEN.

The Report was drawn up in three sections:—

- A. The causes of industrial unrest.
- B. Attempts at diminishing industrial unrest.
- C. Recommendations.

*A. Causes.*

1. The desire for a higher standard of living.
2. The desire of workpeople to exercise a greater control over their lives, and to have some determining will as to conditions of work.
3. The uncertainty of regular employment.
4. The monotony in employment.
5. Suspicion and want of knowledge of economic conditions.
6. The complaint that some labour is irregular and less satisfactory.
7. The effects of war measures.

*B. Attempts at Diminishing Industrial Unrest.*

These include :

1. Conciliation and Arbitration Boards.
2. Arbitration (a) Voluntary.  
(b) Compulsory.
3. Profit-sharing and co-partnership.
4. Co-operation.

*C. Recommendations.*

The aim of this investigation was to discover certain general principles which must underlie an harmonious economic organisation. Before the problems of industrial unrest can be solved, these principles must be applied to particular industries. With their special application this Committee has not dealt, and the recommendations put forward include only broad principles possible of wide application.

They may be divided into groups as they concern :

1. The general attitude and outlook of employers and workmen.
  2. The machinery for dealing with disputes.
  3. The organisation of industry.
  4. Post-war arrangements.
1. (i) That there should be greater frankness between employers and workpeople, and that they should discuss industrial matters together or through duly accredited representatives.
  - (ii) That employers should consider the cost of labour, and not the wages earned by individual workmen.
  - (iii) That the fundamental facts and principles of industrial and economic life should be known by both.
  2. (i) That employers and workpeople should improve their organisations with a view to determining jointly the conditions under which industries should be carried on.
  - (ii) That in each industry permanent boards or committees be set up to consider all matters of common interest.
  - (iii) That there be a joint National Board to which local boards could refer unsettled disputes.
  3. (i) That the necessity for co-operation between employers and employed be recognised by both.

(ii) That employers establish :

- (a) Associations of one trade in a given district.
- (b) National Associations of one Trade.
- (c) Local Federations of Trades.
- (d) National Federations of Trades.

(b and d being organised under a system of representation.)  
That workpeople establish unions and federations corresponding to the above.

(iii) From the two National Federations there be elected an Industrial Council.

(iv) That the State give recognition to approved associations, unions, and federations under carefully devised regulations, the State being the representative of the consumer and of the community.

4. (i) On demobilisation, that district boards of really practical men be established to consider and adjust difficulties, especially as to replacement in industry of men who have joined the Forces.

(ii) As to agreements and regulations in abeyance for the period of the War. The industrial community will have an opportunity for considerable reconstruction. The new organisation suggested should take this in hand.

*Replacement of Men by Women in Industry.—Abstract of the Report of the Committee, consisting of Professor W. R. SCOTT (Chairman), Mr. J. CUNNISON (Secretary), Miss ASHLEY, the Rt. Hon. C. W. BOWERMAN, Professor S. J. CHAPMAN, Ven. Archdeacon CUNNINGHAM, Mr. W. J. DAVIS, Professor E. C. K. GONNER, and Mr. ST. G. HEATH.*

THE activity of the Ministry of Munitions, the schemes for the 'dilution of labour,' and the scarcity of skilled male labour have brought about in the second year of the war a marked development in the demand for female labour. At the present time (July 1916) over half a million women have replaced men who have left their occupations for more urgent national service.

The women who have taken the men's places have for the most part had previous industrial experience, though seldom (in industry proper) of the kind of work they are now doing. Many of them are married women, or single women transferred from other occupations. Generally the supply has been drawn from the neighbourhood, but some of the munitions establishments have attracted women from a wide geographical area, not always limited to the British Isles.

Besides the employment of women on trams and railways, in banks, and as postal servants (positions open to the public view), replacement has occurred through the whole of industry. Few women are to be

found taking the place of highly skilled men; but large numbers have released the unskilled and those termed, in engineering, 'semi-skilled.' But when the work of the men involved a degree of skill and experience which women seldom possess, new machinery of a more automatic kind has been introduced (sometimes to such an extent as almost to transform an industry), and subdivision of processes has changed highly skilled work into a series of repetition operations which can be accomplished by relatively untrained workers. This has to be borne in mind when women are stated to be doing the work of skilled men.

The success of the women on these repetition processes is marked. They learn quickly; they are good time-keepers; they have, so far at least, stood the strain of long hours extremely well, and their manual dexterity enables them to achieve good results in the way of output on repetitive processes. On work demanding greater judgment and adaptability the evidence of their success is not so great; but their industrial training has been short.

For some time the employment of women on men's processes was opposed by Trade Unions, which still in some industries bring forward strong objections to replacement. But in the most important industries agreements have been reached between men and employers as to the conditions on which replacement may be carried out during the period of the war. Those conditions usually include an agreement as to women's wage-rates and a guarantee of the re-employment of the men replaced.

The wages of women in war-time have been influenced by the fixing of a minimum for certain kinds of munition workers in certain classes of munitions establishments; by the competition of munitions with other industries in the demand for female labour; by the pressure of the Trade Unions; and by the general rise in prices. The fact that even in districts where the competition of munitions is keenest the wage-rates for women in other industries, on processes involving similar skill and exertion, have not always risen to the munition level, suggests that the withdrawal of the minimum regulation, twelve months after the war, will lead to a fall in women's wages. But it is unlikely that they will fall to their general pre-war level.

The fact that not a great proportion of the women war workers were previously occupied suggests that after the war the problem of a large surplus of women may not be so serious as has been feared. The married women are for the most part in industry only for the period of the war; and inquiry among women workers generally shows that many of them have no desire to remain in competition with men. But this involves the question of the increased demand for women on repetitive processes; and if, as seems likely, the subdivision of processes and the highly automatic machinery introduced owing to war conditions have come to stay, there may be a change in the relative demand for skilled and for unskilled labour to the disadvantage of the former.

---

*The Effects of the War on Credit, Currency, and Finance.—Report (Abstract) of the Committee, consisting of Professor W. R. SCOTT (Chairman), Mr. J. E. ALLEN (Secretary), Sir EDWARD BRABROOK, Professor C. F. BASTABLE, Professor L. R. DICKSEE, Professor F. Y. EDGEWORTH, Mr. BARNARD ELLINGER, Mr. A. H. GIBSON, Professor E. C. K. GONNER, Mr. FRANCIS W. HIRST, Professor A. W. KIRKALDY, Mr. D. M. MASON, Professor J. SHIELD NICHOLSON, Sir R. H. INGLIS PALGRAVE, and Mr. E. SYKES.*

### I. Introduction.

COMMUNICATIONS invited from America and allied countries. The Committee records its thanks to Professor Gide (Paris), Professors Einaudi, Loria, and Supino (Italy), and Mr. S. Metz (Argentina).

### II. Credit.

Last year's Report dealt with the period of transition from peace to war; 'Credit has now adapted itself to a state of war.' The marked increase in banking deposits is apparently anomalous, but explained by various considerations—*e.g.*, calling in of floating foreign balances from abroad, decrease in outstanding London acceptances, subscriptions by the public and by banks to War Loans, Exchequer bonds, Treasury bills, issue of currency notes, &c.

### III. Currency.

Since last year's Report the credit position has become less abnormal, and the need for emergency currency less; but it is now desirable to concentrate the country's stock of gold. Notes should be marked convertible into gold at Bank of England, though actual conversion undesirable. Adequate gold reserve against notes essential: no increase since last year, while the note issue has been trebled. It is difficult to estimate quantity of gold in country before the war: some of it hoarded, and hoarding seems to have increased.

How far is issue of currency notes an addition to the circulation? The Mint calculation gave 78,000,000*l.* of gold in hands of public on June 30, 1914: notes in hands of public now may not be much more. It is conceivable that there is no increase in money in circulation; but it is possible that the Mint calculation is an over-estimate. Mr. A. H. Gibson thinks pre-war amount under 50,000,000*l.*

### IV. Prices.

What has caused rise in prices? Many reasons offered, 'prompted by certain aspects of the situation which are forced upon the attention of each writer by his own personal experience.' Thus those engaged in monetary transactions explain rise by alterations of the currency; those engaged in manufacture and distribution explain it by quasi-monopoly of producers, intensity of demand of home and foreign Governments, increased cost of production (plant, labour, capital),

and increased taxation. The theory of money must be applied with great care at present, as this is a 'short period,' and it must be distinguished from a normal period. 'Index numbers' afford a fair guide to amount of rise, but are not exhaustive. Professor Charles Gide, of Paris, thinks that the issue of notes, which has been specially large in France, has had very little influence on prices, since in France prices have not risen as much as they have in England.

#### V. *Foreign Exchanges.*

Report first combats impression prevalent abroad (as communicated by Professor Achille Loria, of Turin) that there is 'a moral prohibition on the export of gold,' and that England has in fact 'a non-exportable gold standard.' No doubt great exports have been made. The British Empire controls two-thirds of world's output of gold, therefore no good reason for any moral or patriotic impediment to the most perfect freedom of gold export. Difficulties of American exchange successfully removed by Dollar Securities Scheme. Professor Gide holds that the depreciation of its exchange does not necessarily indicate impoverishment of a country.

#### VI. *Economy, Individual and National.*

There are various types of saving which are of unequal value to the nation. Mistakes arise from thinking in terms of money. We ought to think 'in terms of commodities.' It is clear that the best saving is in imported goods; next in goods which 'are produced under conditions of diminishing return'—*e.g.*, 'saving in the use of wool, coal, food of all kinds, cotton, &c., is highly beneficial.' Economy in public expenditure is 'even more necessary.'

#### VII. and VIII. *War Taxation and Finance.*

Report discusses relative advantages of financing war by loans and by taxation. It is a matter of some doubt whether much additional revenue can be obtained by further taxation of commodities except petrol and spirits. If further revenue is required it must be obtained by a more scientific and equitable income-tax. At present taxation of working-classes is based on their consumption of necessities (apart from tobacco and intoxicants); canon of 'ability to pay' ignored. Amount of tax paid by working man through sugar, tea, and other duties depends on size of his family and not of his income. Conclusion.—Contributions required from working-classes should be taken by income-tax on wages collected through the employer at time of payment.

#### IX. *Economic Conditions after the War.*

#### APPENDIX.

*Diagram illustrating Day-by-day Borrowing.*

By Mr. D. DRUMMOND FRASER.

---

*Stress Distributions in Engineering Materials.—Interim Report of the Committee, consisting of Professor J. PERRY (Chairman), Professors E. G. COKER and J. E. PETAVEL (Secretaries), Professor A. BARR, Dr. C. CHREE, Mr. GILBERT COOK, Professor W. E. DALBY, Sir J. A. EWING, Professor L. N. G. FILON, Messrs. A. R. FULTON and J. J. GUEST, Professors J. B. HENDERSON, F. C. LEA, and A. E. H. LOVE, Dr. W. MASON, Dr. F. ROGERS, Mr. W. A. SCOBLE, Dr. T. E. STANTON, Mr. C. E. STROMEYER, and Mr. J. S. WILSON, to report on certain of the more Complex Stress Distributions in Engineering Materials.*

## [PLATE III.]

DURING the past year the time of the various members of the Committee has been, to a large extent, taken up by work in connection with the war, and some of the researches carried out by Professor Coker and others, although having a direct bearing on the work of the Committee, cannot, at present, be included in the report.

Papers have been received from Mr. Stromeyer, Dr. Stanton, and Dr. Mason, and are published as appendices.

Mr. Stromeyer submits results of tests in tension, compression, and tension and shear made on a number of steels of different compositions.

Dr. Mason has carried out some experiments with the alternating stress machine he recently designed; these show that when the range of cyclic strain in alternating bending or in alternating torsion is not entirely elastic, the range of non-elastic strain varies largely with change of frequency of cycle. Some experiments have been made to investigate the recovery or apparent recovery that takes place when a piece showing 'cyclical permanent set' is allowed to rest. Similar 'recovery' has been found, under certain circumstances, after alteration of frequency of cycle, during tests wherein the range of stress was constant throughout.

Dr. Stanton gives a description of a new machine for tests of materials in combined bending and torsion.

The general result of his work is a confirmation of Guest's hypothesis for the material used.

The Committee ask for reappointment with a grant of 80*l.*

## APPENDIX I.

*An Experimental Comparison of Simple and Compound Stresses.*

By C. E. STROMEYER.

The following experiments were carried out on twenty-six samples of mild steel of which the chemical analyses and many mechanical tests have been previously reported. *Vide* 'Journal Iron and Steel Inst.' 1907 I., 1907 III., 1909 I.; 'Proceedings R.S.,' 1915; 'Trans. Inst. Naval Architects,' 1915.

The object of the present set of experiments was in part to trace a relationship between tension, compression, and shear stresses, in order



to test the applicability of Guest's law with regard to elastic limits, plastic limits, and ultimate strengths, for each of which breakdown points the tension and compression stresses should according to Guest's law be equal and twice as great as their combinations: the shearing stresses.

*Ultimate Strengths.* TABLE I.

The ultimate crushing strengths were not obtainable. The ordinary tensile strengths, T, were obtained by the usual method of dividing the original cross-section of the samples into the maximum loads recorded during the tests. The tenacities per reduced section, T<sub>r</sub>, were, as the name implies, obtained by dividing the reduced section of the sample, at the point of fracture, into the smallest recorded load at the moment of fracture. On account of the unsteady conditions near the moments of fracture it was not always possible to determine these loads with

TABLE I.  
*Ultimate Strengths.*

Samples	Ultimate Tenacities		Tenacities per Reduced Sections		Ultimate Shearing Strengths		S/T	S/T <sub>r</sub>
	Estimated	Observed T	Estimated	Observed T <sub>r</sub>	Estimated	Observed S		
	Tons	Tons	Tons	Tons	Tons	Tons		
D	23·78	23·60	40·20	36·57	20·72	21·23	0·90	0·58
A	24·22	24·11	48·16	50·48	27·44	22·00	0·91	0·44
M	25·18	24·90	53·96	58·22(-)	24·42	—	—	—
X	25·38	24·60	50·52	48·17	23·12	21·05	0·86	0·44
U	25·94	25·30	49·66	53·12	23·29	22·86	0·90	0·43
P	26·33	25·50	54·64	56·74	24·50	24·10	0·95	0·42
S	26·56	26·00	54·24	53·33	24·54	22·90	0·88	0·43
B	27·31	27·40	52·52	56·24	25·10	24·90	0·91	0·44
T	27·33	28·20	54·10	62·62(-)	24·42	25·72	0·91	0·41(+)
L	27·40	26·30	56·32	60·56(-)	25·39	24·40	0·93	0·40(+)
BB	27·43	27·60	54·32	51·20	24·44	23·34	0·85	0·46
N	27·57	26·27	55·38	58·62(-)	24·85	23·72	0·90	0·40(+)
E	27·57	30·60	51·28	58·42(-)	24·45	23·12	0·76	0·40(+)
J	27·85	28·10	54·14	67·86(-)	24·63	24·85	0·89	0·36(+)
Q	28·81	28·50	54·76	58·77	25·06	29·93	0·91	0·44
V	28·90	29·60	54·70	54·88	24·79	25·00	0·85	0·46
Z	28·97	29·70	55·72	49·33	24·94	24·74	0·83	0·50
F	29·51	28·90	58·78	57·00	27·10	26·60	0·92	0·47
K	29·94	27·80	55·02	54·96(-)	25·33	25·15	0·90	0·46(+)
G	30·66	31·30	57·84	60·88	25·85	27·50	0·88	0·45
R	31·26	32·10	60·68	62·80	27·35	27·65	0·86	0·44
W	31·59	31·80	57·48	61·26(-)	25·90	27·11	0·85	0·43(+)
H	32·60	33·70	58·40	64·81(-)	26·65	28·37	0·84	0·44(+)
C	33·84	33·30	55·76	51·72(-)	25·73	26·41	0·80	0·51(+)
Y	37·69	37·40	68·58	66·96	28·97	29·70	0·79	0·44

The above estimated stresses are found by the formulæ

$$\begin{aligned}
 T_1 &= 19\cdot75 + 25(C + C^2) + 11\cdot5 Si + 30 P + 205 N - 11\cdot5 S + 36\cdot5 As \\
 T_r &= 50\cdot5 + 20 C \quad \quad \quad + 20 Si + 40 P + 200 N - 80 S \\
 S &= 22\cdot2 + 9 C \quad \quad \quad + 6 Si + 20 P + 100 N - 20 S.
 \end{aligned}$$

(-) These stresses may be too high. (+) These ratios may be too low.

TABLE II.

*Elastic and Plastic Limits.*

	TENSION				COMPRESSION		SHEAR			
	Elastic Limits		Plastic		Elastic Limits		Elastic Limits		Plastic	
			Limits	Drops					Limits	Drops
	T <sub>e</sub>	T <sub>c</sub>	T <sub>p</sub>	T <sub>d</sub>	C <sub>c</sub>	C <sub>c</sub>	S <sub>c</sub>	S <sub>c</sub>	S <sub>p</sub>	S <sub>d</sub>
Tons	Tons	Tons	Tons	Tons	Tons	Tons	Tons	Tons	Tons	
D	15·5b	16·50b	18·0	18·0	20·0bb	22·63	9·0	11·66	10·9	9·7
A	16·6b	20·90!	Grad	ual	14·6b	15·99	8·0	11·87	12·0	10·6
M	16·5!	—	17·5	17·5	20·2!	19·61	9·0b	11·79	10·7	9·0?
X	16·3b	19·13!	18·4	18·4	14·1b	12·56	9·4	9·50	10·4	9·4
U	18·81!	18·61!	19·7	19·5	—	—	10·5	11·38	11·5	10·4?
Q	17·45	18·03b	18·1	18·1	—	—	11·0	12·24	11·2	10·4
S	17·2bb	21·31b	21·2	20·9	15·1b	15·80	10·0b	12·30	10·1	9·9
B	17·4!!	17·84!	19·0	—	16·9!	17·25	9·0	12·50	11·6	10·1
T	13·0bb	17·35b	—	—	13·4b	18·77	9·0	12·00	11·2	10·4
L	17·9b	19·11b	21·3	21·2	15·7!!	19·78	11·7	12·42	12·3	11·0?
BB	19·8b	20·01b	21·2	21·3	14·1b	18·66	9·0b	13·20	11·9	10·8?
N	11·4bb	13·01b	16·4	16·1	14·6!	16·80	9·0	10·84	9·2	8·0?
E	21·4b	26·08!!	28·4	28·4	14·5b	18·45	13·6	16·15	14·6	13·4
J	18·7b	17·92b	20·0	20·0	16·6b	17·65	11·8b	13·59	12·9	—
Q	22·9!	24·58!	23·2	23·1	17·0bb	20·60	14·6	15·09	14·5	12·6
V	20·0b	24·89!	23·	23·0	16·7!	18·38	10·5	15·50	13·4	12·6
Z	20·0!	21·20b	20·3	20·3	15·6bb	14·94	10·0	12·60	11·8	—
F	19·5!	20·01!!	20·2	20·2	16·7b	18·98	10·5b	14·00	12·6	11·3
K	18·8!	18·46!	21·0	21·0	18·2!	20·13	11·3	13·20	12·2	—
G	13·7bb	24·51!	23·5	23·2	15·1bb	19·58	12·5	14·35	13·6	11·9
R	17·6bb	24·90!	23·0	22·6	18·0bb	20·68	12·7	16·50	14·2	12·5
W	20·1b	24·38b	23·1	23·1	16·0!!	18·94	9·0	13·40	12·2	11·0?
H	21·3b	24·29!	24·4	24·4	17·0bb	22·14	14·8	15·50	14·9	12·9
C	17·71	18·00!	21·0	—	16·1b	18·87	12·0	13·60	12·7	11·3
Y	20·8bb	25·64b	Grad	ual	25·0!!	23·12	14·5	15·92	15·7	14·6

(!) Well defined limits.

(?) In these cases there were too few observed stresses to make accurate estimates of the 'drops.'

(b) Ill defined limits.

accuracy. The ultimate shearing strengths, S, were obtained from the torsion tests as explained below. In these cases, too, the unsteady conditions at the ends of the tests interfered with the accuracy. Nevertheless we find that the ratio S/T<sub>p</sub> is fairly constant but rather less than 0·5 as required by Guest's law. The ratios S/T vary from 0·756 to 0·946 and seem to be of no value.

Table I. also contains the estimated ultimate strengths estimated from three formulæ there given. The agreement between the estimated and actual stresses is remarkably good in the case of T. The two other formulæ are of interest because the constants for T<sub>p</sub> are approximately twice as great as those for S.

Possibly with an increased number of experiments the agreement may prove to be a closer one. It should be noted that the influence of nitrogen

TABLE III.

Samples	Ratios of Shear Limits to Tension and Compression Limits					
	$S_c/T_e$	$S_c/C_e$	$S_c/T_c$	$S_c/C_c$	$S_p/T_p$	$S_d/T_d$
D	0.58	0.45	0.71	0.51	0.60	0.54
A	0.48	0.55	0.57	0.74	—	—
M	0.54	0.45	—	0.60	0.61	0.51(?)
X	0.58	0.66	0.50	0.76	0.56	0.52
U	0.56	—	0.61	—	0.58	0.53(?)
P	0.63	—	0.68	—	0.62	0.57
S	0.58	0.66	0.58	0.78	0.47	0.47
B	0.52	0.53	0.70	0.72	0.60	—
T	0.69	0.67	0.69	0.64	—	—
L	0.66	0.78	0.65	0.63	0.58	0.52(?)
BB	0.45	0.64	0.66	0.71	0.56	0.51(?)
N	0.79	0.48	—	—	—	—
E	0.67	0.62	0.84	0.65	0.56	0.50
J	0.63	0.94	0.62	0.88	0.51	0.47
Q	0.63	0.71	0.76	0.77	0.64	—
V	0.74	0.86	0.61	0.73	0.62	0.54
Z	0.52	0.63	0.62	0.84	0.59	0.54
F	0.50	0.64	0.59	0.84	0.58	—
K	0.54	0.63	0.70	0.74	0.62	0.56
G	0.60	0.62	0.71	0.65	0.98	—
R	0.91	0.83	0.59	0.73	0.58	0.51
W	0.72	0.70	0.66	0.80	0.62	0.55
H	0.45	0.56	0.55	0.71	0.53	0.48(?)
C	0.69	0.87	0.64	0.70	0.61	0.53
Y	0.68	0.75	0.76	0.72	0.60	—
Y	0.70	0.62	0.58	0.69	—	—

(?) See footnote Table II.

is about ten times greater than that of carbon, and that therefore analyses which omit this constituent are valueless for comparisons like the present.

Tables II. and III. deal with elastic and plastic limits on the above lines, but as these limits are badly defined it has seemed desirable to record not only the first indications of curvature in the elastic lines, viz.  $T_e$ ,  $C_e$ , and  $S_e$  for tension, compression and shear, but also those stresses  $T_c$ ,  $C_c$ , and  $S_c$  when the strain-indicator pointers commenced to creep after the additions of small loads. Under the tension and shearing stresses the material seemed to break down at certain badly defined stresses, which might be called plastic limits  $T_p$  and  $S_p$ , and sometimes this breakdown resulted in what is generally known as 'drop'  $T_d$  and  $S_d$ , the steel-yard dropping without additional loading. Both  $S_p$  and  $S_d$  have been estimated from the torsion tests as explained in the note at the end of the paper.

As will be seen from Table III. the several ratios vary within the following limits:—

Ratios	$S_c/T_e$	$S_c/C_e$	$S_c/T_c$	$S_c/C_c$	$S_p/T_p$	$S_d/T_d$
From	0.448	0.448	0.497	0.515	0.474	0.472
To	0.908	0.938	0.836	0.876	0.645	0.575

It will be seen that only the last two ratios, and especially the last one, are at all steady. The conclusion may therefore be drawn that

Guest's law does not apply to elastic limits as at present defined, but only to the drop stresses. This is perhaps natural, for the drop or minimum stress after the general breakdown is probably the natural resistance of the material, whereas the elastic limits may have been affected by preliminary strainings and by ageing effects. It should also be mentioned that the changes of curvature of the elastic lines are very much more marked in the tension and compression cases  $T_e$  and  $C_e$  than in the shearing (torsion) cases, for in these latter it is only the outer fibres of the samples which are affected.

Both in the tension and the compression experiments two strain indicators were used and corrections were made in the final results for eccentricity of pull. These corrections were less than 10 ton for the tension tests. Duplicate tests on the same material demonstrated that these corrections are necessary and that the methods adopted are fairly correct.

#### *Note on Shearing Stress Strain Diagrams.*

The problem is to determine the shearing stress strain curve from the torsion moment or stress strain curve.

Assume that two similar cylindrical shells of the respective semi-diameters  $x_1$  and  $x$  and the thicknesses  $dx$  and  $dx$  are subjected to equal circumferential shearing stresses  $S$ , then the respective torsion moments  $dM_1$  and  $dM$  stand in the relation

$$dM_1/dM = x_1^3/x^3.$$

This relation holds good for a number of concentric cylindrical shells constituting a solid bar, provided of course that the stress distribution is similar in each bar of the respective radii  $r_1$  and  $r$ .

$$M_1/M = r_1^3/r^3.$$

Let  $r_1 = r + dr$ , then  $M_1 = M(r + dr)^3/r^3 = M\left(1 + \frac{3dr}{r}\right)$ .

Assume that the smaller of the two rods of the radius  $r$  receives the addition of a thin cylindrical shell of the thickness  $dr$ , then its diameter will be the same as the other bar, and if this added cylinder be stressed circumferentially with the stress  $S$ , which exists in its original outer fibre, then the torsion moment  $M_2$  for this compounded bar is:—

$$M_2 = M + 2\Pi \cdot Sr^2 \cdot dr.$$

These two torsion moments  $M_1$  and  $M_2$  would be obtained with one and the same bar if in the first one, the shear strain angle at the surface, were  $a_1$ , and if in the second it were:—

$$a_2 = a_1(r + dr)/r = a_1\left(1 + \frac{dr}{r}\right), \text{ then as } da = a_2 - a_1 = a \frac{dr}{r}$$

we may in the above equations replace  $dr/r$  by  $da/a$ , and combine them as follows:—

$$M_2 - M_1 = dM = 2 \cdot \Pi \cdot Sr^2 \frac{da}{a} - 3M \frac{da}{a}$$

and we have:—

$$S = \frac{2}{\Pi r^3} \left( \frac{3}{4} M + a \frac{dM}{da} \right).$$

As long as the elastic limit of the material of a bar of the diameter  $d = 2r$  is not exceeded, the torsional resisting moment is

$$M = S_e \cdot d^3 \pi / 16 = S_e \cdot r^3 \pi / 2.$$

If therefore from the observed torsion moment we estimate shearing stresses  $S_e$  as if the material were perfectly elastic, then the plastic stresses are

$$S = S_e \left( \frac{3}{4} + \frac{1}{4} \frac{\alpha}{M} \frac{dM}{d\alpha} \right).$$

This formula has been used for estimating the plastic shearing limits and drops from the torsion curves. Beyond these limits  $dM/d\alpha$  is negligibly small and the ultimate shearing stresses are therefore

$$S = \frac{3}{4} S_e.$$

## APPENDIX II.

### *On the Hysteresis of Steel under Repeated Torsion.*

By W. MASON, D.Sc.

Recent experiments<sup>1</sup> have shown that elastic hysteresis becomes rapidly greater with increasing range of stress. At a range of 8.5 tons per square inch, the width of the hysteresis loop for an annealed steel tube, measured in stress, amounted to 0.15 tons per square inch.

The question arises whether the hysteresis found with stress-ranges which extend beyond what are believed to be the natural elastic limits is or is not of the same nature as elastic hysteresis.

The following set of experiments was one of several made in order to get further information on this point.

A turned and bored hollow specimen (see figure) of the dead mild steel provided by the Stress Distribution Committee of Section G of the British Association was fixed in an alternating torsion-testing machine wherein the torque, direct and reverse, was applied by a lever which could be operated either by mechanism or loaded by dead weights. The grips holding the ends of the specimen were centred inside ball-bearings, and care was taken to eliminate any friction that might affect the value of the applied torque. The range of the angle of twist was measured by mirrors bolted to the specimen (see figure). The image of a fixed scale was reflected in turn by each mirror, and was received in a fixed telescope. The mirrors remained fixed to the specimen throughout, and neither the scale nor telescope was moved during the experiments; but if any small displacement of these latter, for any cause, did occur, there could be no effect on the range of torsional strain or width of hysteresis loop observed.

The Table explains the scheme of the experiments.

The readings in columns *a*, *b*, *c*, *d*, *e* are accurate to within  $\pm 0.1$  scale divisions, and the accuracy of the range of strain and of the width of hysteresis loop is certainly well within  $\pm 0.2$  scale divisions. The arrangement for observing the torsional strain is intended for measurement of comparatively large ranges of angular twist, and not for the accurate measurement of the elastic hysteresis.

<sup>1</sup> 'Elastic Hysteresis in Steel,' F. E. Rowett.—*Proc. Roy. Soc. A.*, Vol. 89, 1914.

All the readings given in columns *a*, *b*, *c*, *d*, and *e* are for the tests in which the torque was applied by weights. During the intermediate runs of repeated stressing at the frequency of 200 per minute, readings were taken of the range of strain which corresponded very fairly (see Table)—up to Test No. 7—with the ranges obtained in the dead-weight tests at the same ranges of stress. The former readings, *i.e.* at 200 per minute, are read to the nearest .05 scale division. It will be noticed that there was a distinct increase of range of strain and of width of hysteresis loop during the 36,000 cycles at  $\pm 5.50$  tons per square inch; and a larger increase in both of these during the 228,000 cycles at  $\pm 5.62$  range. Also at the change of speed, after the run of 228,000, from 200 to 8 cycles per minute, the range of strain altered from 6.90 to 7.24; this is an example of the speed effect already found by the author in previous work.<sup>2</sup>

It appears, then, that for the steel tested there is a limit to elastic ranges of strain in the neighbourhood of  $\pm 5.50$  tons per square-inch range of stress. A torsion test, made with continuously increasing torque, of another specimen (solid) cut next in order to the specimen of these tests from the same bar of steel, gave a yield point of 9.85 tons per square inch, and a limit of proportionality in the neighbourhood of 5.80 to 6 tons per square inch.

After Test No. 8 (see Table), a succession of tests at smaller ranges of stress showed the hysteresis loop to be wider even than at the higher ranges of stress of the cycles imposed before the limit to the elastic ranges

TEST SPECIMEN.

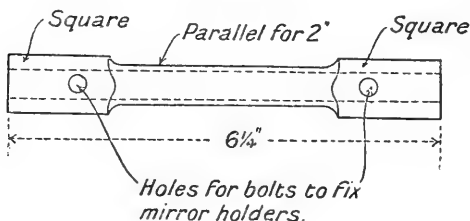

of stress had been passed. The apparent recovery of elasticity with rest in Test No. 15 is presumably the counterpart for alternating cycles of the well-known phenomenon of recovery with rest after overstrain.

The foregoing experiments illustrate the following points:—

At a range of stress—applied by equal direct and reverse torsion—which may be determined with considerably more accuracy than the elastic limit in a static test (*i.e.* with slowly increasing stress in one direction), the hysteresis increases largely with continued application of the cycles. At a smaller range of stress, the increase of hysteresis, if any, is very small and may probably be regarded as an increment of elastic hysteresis. Other of the author's tests have shown that 250,000 cycles

<sup>2</sup> 'On Speed Effect and Recovery in Slow-speed Alternating Stress Tests.'—*Proc. Roy. Soc. A*, vol. 92, 1916.

TABLE IV.

No. of Test	Conditions of Test	Range of Stress		Range of Load on Lever		Readings on Scale					Range of Strain	Width of Hysteresis Loop
		Tons per Sq. In.	Lb.	No Load	Max <sup>m</sup>	No Load	Max <sup>m</sup>	No Load	Max <sup>m</sup>	No Load		
		$a$	$b$	$c$	$d$	$e$						
1	After putting specimen into machine . . . . .	±5.00	±10.45	12.60	15.51	12.59	9.65	12.56			5.86	0.03
Specimen given 31,600 cycles at 200 per minute at Range of Stress ±5.00. Range of Strain 5.90												
2	After 31,600 cycles of ±5.00 tons sq. in. . . . .	±5.00	±10.45	12.55	15.50	12.58	9.65	12.55			5.85	0.03
3	Following Test No. 2 . . . . .	±5.25	±10.97	12.55	15.66	12.57	9.50	12.53			6.16	0.04
Specimen given 12,400 cycles at 200 per minute at Range of Stress ±5.25. Range of Strain 6.15												
4	After 12,400 cycles of ±5.25 tons sq. in. . . . .	±5.25	±10.97	12.56	15.64	12.60	9.51	12.55			6.13	0.05
5	Following Test No. 4 . . . . .	±5.50	±11.50	12.55	15.80	12.59	9.35	12.54			6.45	0.05
Specimen given 36,000 cycles at 200 per minute at Range of Stress ±5.50. Range of Strain 6.45, but increasing to 6.50												
6	Test after 36,000 cycles of ±5.50 tons sq. in. . . . .	±5.50	±11.50	12.55	15.84	12.61	9.34	12.53			6.50	0.08
7	Following Test No. 6 . . . . .	±5.62	±11.75	12.53	15.87	12.61	9.28	12.53			6.59	0.08
Specimen given 228,000 cycles at 200 per minute at Range of Stress ±5.62. Range of Strain increasing from 6.60 to 6.90.*												
8	Immediately after 228,000 cycles at ±5.62 tons sq. in. . . . .	±5.62	±11.75	12.32	16.21	12.85	8.97	12.31			7.24	0.54
9	Cycles at smaller ranges of stress, following Test No. 8	±4.78	±10.0	12.35	15.58	12.73	9.57	12.40			Loop not closed	
10		±4.78	±10.0	12.40	15.56	12.72	9.57	12.41			6.01	0.31
11		±3.82	±8.00	12.41	14.90	12.64	10.22	12.49			Loop not closed	
12		±3.82	±8.00	12.49	14.90	12.64	10.24	12.49			4.66	0.15
13		±2.87	±6.00	12.49	14.28	12.58	10.82	12.50			3.46	0.08
14	±2.87	±6.00	12.50	14.27	12.57	10.84	12.50			3.43	0.07	
Specimen allowed 52 hours' rest at zero stress												
15	After 52 hours' rest . . . . .	±2.87	±6.00	12.50	14.25	12.55	10.85	12.50			3.40	0.05

\* At the end of this run the range of strain at the frequency of 8 cycles per minute was 7.24.

of a range of stress somewhat below the above-mentioned limiting range do not cause an increment of hysteresis measurable by the same apparatus as used for the tests cited in this note.

The large increase of hysteresis due to repetitions of a range slightly exceeding this limiting range cannot be regarded as increased elastic hysteresis for two reasons :—

(1) Because on subsequent application of much less ranges of stress the hysteresis retains an augmented value which appears to be much more than what can be regarded as elastic hysteresis, and (2) the large increase of range of strain is not independent of the speed of cycle ; for, as previously shown by the author<sup>3</sup> (see also Test No. 8), a reduction of frequency of cycle gives an increase of range of strain, and *vice versa* ; whereas Rowett<sup>4</sup> has found that the area of the elastic hysteresis loop is the same at low and high speeds within 5 per cent.

At this limiting range of stress there appears to be a definite impairment of elasticity with repetition of cycle, and the increased hysteresis is most probably the coarser form of hysteresis believed to be due to crystalline slipping.

### APPENDIX III.

#### *On the Fatigue Resistance of Mild Steel under Various Conditions of Stress Distribution.*

By Dr. T. E. STANTON and Mr. R. G. BATSON.

The material on which the experiments described in this Report were made was a special sample of mild steel procured for the Committee by Dr. F. Rogers. The ordinary mechanical properties of the steel have been investigated fairly completely, and the results of the tests are given in the Report for 1915. It should be mentioned that the specimens used were prepared from the 1-5/16" bar, and were not heat-treated before testing. The results of a tensile test on the bar used give results which were practically identical with those obtained by Mr. Cook (see Report 1915, p. 160), and were :—

Yield Stress . . . .	13·5 tons per sq. inch.
Maximum Stress . . . .	22·4 " " "
% Extension $\left(\frac{l}{d}=3\cdot5\right)$ . . . .	49·0 " " "
% Contraction of Area at Fracture . . . .	70·8
Modulus of Elasticity . . . .	$29\cdot7 \times 10^6$ lb. per sq. inch.

The scheme of experiments was the determination of the fatigue resistance of solid cylindrical specimens subject to rapid alternations of a combined bending and twisting moment of given value and such that the ratio of bending moment to twisting moment could have any

<sup>3</sup> *Proc. Royal Soc. A*, vol 92.

<sup>4</sup> *Proc. Royal Soc. A*, vol. 89.



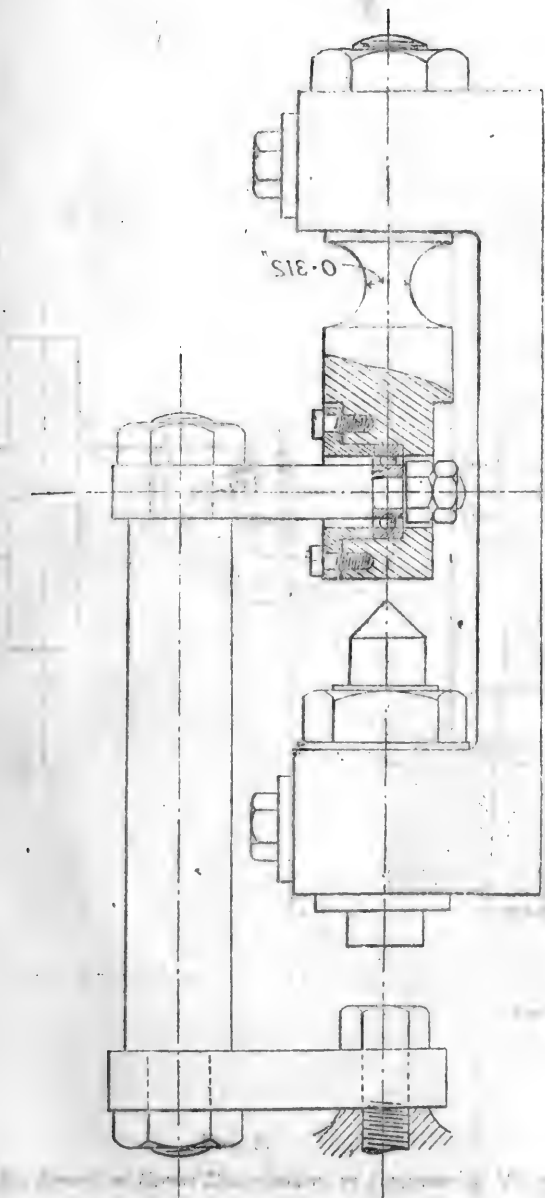

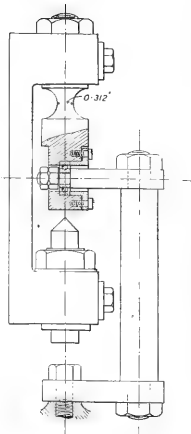
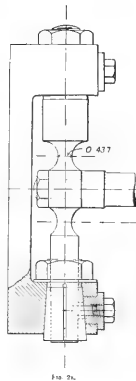
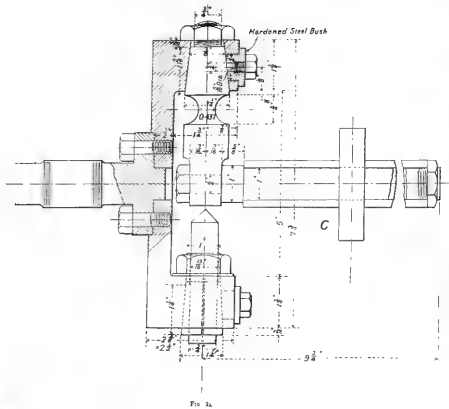

FIG. 2  
Illustrating the Report on Stress Distributions in Engineering Materials.

desired value between the extreme cases of reversals of simple bending and reversals of simple torsion.

The fatigue-testing machine in which the experiments were made was specially designed and constructed for the purpose of the research in the engineering workshop of the National Physical Laboratory. The general principle of the machine will be seen from fig. 1, which is a diagrammatic representation of the manner in which the combination of bending and

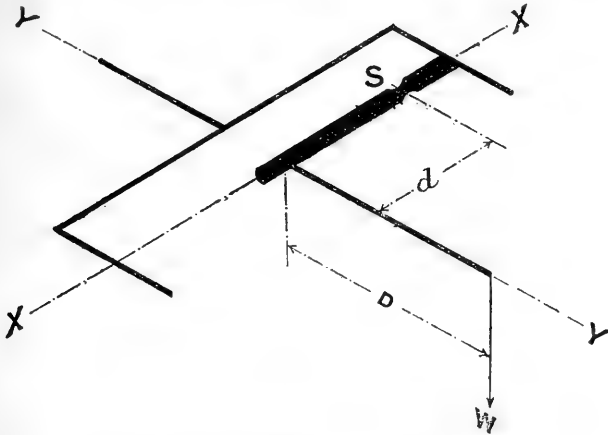

FIG. 1.

twisting is applied to the specimen. In the position shown, the cross-section of the specimen at  $S$  is subject to a twisting moment  $WD$ , and to a bending moment  $Wd$ . When the head has turned through  $180^\circ$  the moments will be equal in amount but opposite in sign. When the head has turned through  $90^\circ$  from the position shown the maximum stress will be that due to a bending moment  $WD$  plus that due to the direct loading, but as in all cases this stress is below the known fatigue limit of the material under reversals of simple bending, its effect is supposed to be negligible, and the specimen is assumed to be subject to reversals of the combination of bending and twisting moment alone.

The form of specimen adopted is shown in fig. 2A,<sup>5</sup> which represents a plan of the testing head with the specimen and hanger in position. By varying the length of the collar  $c$ , and also, if necessary, the position of the neck of the specimen, relative to the axis of rotation of the specimen, it will be seen that the ratio of bending moment to twisting moment can be varied within fairly wide limits.

For the experiments in which the stresses were practically reversals of simple shear, the arrangement described above was not suitable, and the method of making the torsion tests is shown in fig. 2B. In this case it will be seen that the fatigue of the specimen takes place simultaneously

<sup>5</sup> It was found on trial that the variation of sectional area in the neighbourhood of the neck of the specimen, shown in fig. 2A, was a source of weakness and in the tests, of which the results are given in Table V., the form of the specimen was slightly modified.

over two sections symmetrically placed about the axis of rotation. In the tests the distance of the hanging weight from the axis of the specimen was  $8\frac{1}{2}$  inches, so that the ratio of the twisting moment to the bending moment was about 20.

For reversals of simple bending, a test of a specimen in an ordinary fatigue-testing machine of the Wöhler type would have been sufficient for the prediction of the fatigue limit. It was considered, however, of fundamental importance to determine if the effect of the reversals of bending produced in this machine were of the same amount as those produced by the continuous rotation of a loaded bar as in the ordinary Wöhler test, and for this purpose a special device was employed, which is illustrated in fig. 2c, which is an elevation of the testing head with the specimen in position. It will be seen that the axis of the load is made to intersect the axis of the specimen, *i.e.* the torsional moment is made zero, by extending the hanger so as to envelop the head when rotating, and the load is transmitted to the specimen through the ball-bearing in the specimen itself. In this way reversals of simple bending are produced in the specimen, the essential difference between this case and the Wöhler test being that in the former the maximum stress is confined to the axial plane in the specimen perpendicular to the axis of rotation.

#### *The Method of Carrying Out the Tests.*

In the ordinary system of testing for the prediction of the limiting fatigue range of stress it is customary to have a fairly large number of specimens, and to commence by imposing a range of stress which will probably cause fracture after a few thousand reversals. The next specimen is then tested under a smaller stress range, and so on until a range is found which the specimen will bear indefinitely. In the present case the cost of each specimen was so considerable that the reverse method to the above was adopted, *i.e.*, a comparatively small range was first imposed, and if after three million reversals fracture had not occurred, the load was increased by about five per cent., and the test carried on. Finally a stage was reached when fracture took place with less than three million reversals. A new specimen was then fitted to the machine and tested at what was considered to be the limiting range. In this method the time taken in the series of tests required for the prediction of the fatigue limit is longer than in the former case, but considerable economy in the cost of preparation of specimens is effected.

*Results of the Tests.*

The results obtained up to the present are given in the following table:—

TABLE V.

*Limiting Fatigue Range of Stress for British Association Mild Steel Specimens prepared from the 1-5/16 in. round bar and not heat-treated.*

Ratio of Twisting Moment to Bending Moment	Pounds per Square Inch				Remarks
	Tensile Stress on Plane Perpendicular to Axis of Specimen	Shear Stress on Plane Perpendicular to Axis of Specimen	Maximum Principal Stress	Maximum Shear Stress	
0	±25000	—	±25000	±12500	Experiments made on testing machine of Wöhler type running at 2,000 revs. per minute.
0	±25000	—	±25000	±12500	Combined Stress Testing machine running at 2,000 revs. per minute.
1·16	±15700	± 9100	±19750	±11900	Ditto.
1·45	±13700	± 9800	±18750	±11900	Ditto.
1·83	±11500	±10300	±17550	±11800	Ditto.
2·50	± 9000	±11100	±16500	±12000	Ditto.
About 20	± 1260	±12580	±13230	±12600	Ditto.

## REMARKS ON THE TESTS.

It will be seen in the first place that the results under alternations of bending in one plane are in agreement with those obtained under alternate bending in rotating planes as in the Wöhler test, so that results obtained in the two types of machines are comparable.

Further, the limiting shear stresses in the pure bending and in the pure torsion tests are seen to be in close agreement.

Finally, although in the four cases of combined stress the limiting maximum shear stresses seem to be appreciably below the values for pure bending and pure torsion, the general agreement is so close that further investigation is required before it can be stated definitely that the result indicated is a real one. This investigation is now in hand.

## GENERAL CONCLUSIONS.

Although the number of tests carried out up to the present does not justify any general conclusion as to the nature of the criterion for ultimate failure, the general results of the investigation appear to demonstrate that, as a first approximation, Mr. Guest's hypothesis that failure is due to a particular value of the maximum shear stress may be applied to this particular steel.

*Gaseous Explosions.*—*Interim Report of the Committee, consisting of Dr. DUGALD CLERK (Chairman), Professors DALBY (Secretary), W. A. BONE, F. W. BURSTALL, H. L. CALLENDAR, E. G. COKER, and H. B. DIXON, Drs. R. T. GLAZEBROOK and J. A. HARKER, Colonel H. C. L. HOLDEN, Professors B. HOPKINSON and J. E. PETAVEL, Captain H. RIALI SANKEY, Professors A. SMITHELLS and W. WATSON, Mr. D. L. CHAPMAN, and Mr. H. E. WIMPERIS.*

DURING the session most of the members of the Committee were engaged on work in connection with the war, and no Notes were submitted for consideration. Only one meeting to deal with routine business and to consider as to future arrangements was therefore held. Consequently the grant of 50*l.* made to the Committee at the Manchester meeting of the Association in 1915 was not drawn upon by the Chairman.

The Committee recommend that they be reappointed, and that a sum of 50*l.* be granted to them for the ensuing session, so that should the war come to an end during that time the work of the Committee could be resumed without delay.

*Exploration of the Palaeolithic Site known as La Cotte de St. Brelade, Jersey.*—*Report of the Committee, consisting of Dr. R. R. MARETT (Chairman), Mr. G. F. B. DE GRUCHY (Secretary), Dr. A. KEITH, Dr. C. ANDREWS, the late Dr. A. DUNLOP, Colonel R. GARDNER WARTON, and Mr. H. BALFOUR.*

#### *Report of Work done in 1916.*

*Scheme of Operations.*—The collapse of the cave roof in September 1915 caused the workings to be encumbered by some 500 tons of rock rubbish, to which the winter rains added another 200. These accumulations were cleared away in February and March 1916, the work occupying eight weeks and three days. To save expense, the heavier stuff was dumped into the part of the cave already dug out, so as only to leave a sufficient fairway some 15 feet broad. In July and August for seven weeks excavation of the implementiferous bed was resumed. This bed now lay 30 feet from the entrance in the middle of the cave and 8 feet further in along the western wall. The superincumbent débris had been removed down to 15-20 feet above floor-level, as far back as a line 50 feet from, and parallel with, the entrance. Behind this line the débris rose sheer for 50-70 feet above floor-level, being especially dangerous at the N.E. corner. It was decided to limit exploration to the western side of the cave, corresponding to the Working A of former years, as being the easier and safer task. In the meantime it was found possible to attack the débris of the N.E. corner from the back—viz., from the cliff face to the north, and so eventually to break right through into the cave, after removing everything loose down to the level of the top of the human deposit. Thus this year's programme entailed a relatively large amount of labour spent on the sterile portions

of the cave-filling—labour which, however, has rendered it probable that the work can be brought to a finish next year. On the other hand, Working A proved fairly rich up to the point to which it was carried—namely, 53 feet from the entrance; and the archæological spoil is of considerable value.

*Bone.*—Bone was plentiful, but in a bad state owing to damp. It was distributed in pockets, in one case a magma of bone-fragments, mostly of reindeer and horse, occupying a space of some two cubic feet. The best specimens have been forwarded to the British Museum, where they still await full determination. A large and complete tine from the antler of a deer shows striations which are seemingly due to human use, if hardly human design. A well-developed rodent bed occurred beyond the 50-foot line at an unexpectedly high level, and may turn out to have stratigraphical value when this part of the bed is more thoroughly excavated. Three fresh species of rodents have already been determined from this year's finds.

*Stone Implements.*—As regards flint, out of 803 pieces no less than 610 showed signs of use, and of these 420 were trimmed, including 33 implements of first quality. Among the implements of second quality, to adopt the classification already employed (see *Archæologia*, LXVII., 97f), 43 are long flakes with two trimmed side-edges, 89 long flakes with one trimmed side-edge, 84 square, 25 hollowed, none curved, 1 sharpened, 25 keeled, 39 discoidal, and 81 dwarf. Whereas in the outer portions of the cave the ratio of trimmed to untrimmed pieces was less than one in three, at the back it was about equal, presumably because most of the knapping responsible for the flint refuse was done near the entrance where the light was good. As regards stone other than flint, of 311 hammer-stones (182 being of granite and 129 of greenstone) nearly all showed signs of use, while 175 were more or less fractured. Such hammer-stones, to use the term without prejudice, occurred chiefly in conjunction with the pockets of bone-fragments. It is a remarkable fact that whereas the ratio of such hammer-stones to the flint pieces was but  $5\frac{1}{2}$  per cent. in the outer part of the cave, here at the back it actually amounted to  $37\frac{1}{2}$  per cent. Evidently the back of the cave served some specialised use, possibly a culinary one, which brought these pebbles into play. It may be noted that 63 per cent. of the hammer-stones from this Mousterian cave are 40-80 mm. long (700 being measured), whereas from the Neolithic kitchen-midden of Le Pinacle in Jersey  $64\frac{1}{2}$  per cent. were below 40 mm. in length (600 being measured), the inference perhaps being that the later people had smaller or weaker hands. A selection of the 1916 implements is being presented, with the consent of the Société Jersiaise, to the Universities of Oxford and Cambridge.

*Acknowledgments.*—The Chairman and Secretary were in charge of the work throughout. Mr. R. de J. F. Struthers, M.A., B.Sc., Mrs. Holland and her son, Mrs. Jenkinson and Miss Moss came from Oxford and rendered invaluable aid. Many local helpers also assisted, notably Mr. E. T. Nicolle, Mr. H. J. Baal, Mr. E. F. Guiton, and Mr. G. Le Bas, B.Sc. Mr. E. Daghorn, the contractor, showed his usual skill, taking risks freely, and, indeed, twice narrowly escaping

a serious accident. The funds were furnished partly by the British Association and partly by the Government Grant Committee of the Royal Society.

---

*Archæological Investigations in Malta.—Report of the Committee, consisting of Professor J. L. MYRES (Chairman), Dr. T. ASHBY (Secretary), Mr. H. BALFOUR, Dr. A. C. HADDON, and Dr. R. R. MARETT.*

*The Excavations conducted at Ghar Dalam (Malta) in July 1916.*  
By Mr. G. DESPOTT.

A GRANT of 10*l.* having been accorded by the British Association for conducting further excavations in Malta, Ghar Dalam was again chosen as the most important and promising site. As this is not, however, yet Government property, permission had to be asked from its proprietor, Mr. G. Bezzina, P.L., who very kindly gave us full liberty to carry on the work.

Since the excavations conducted by Dr. Ashby in May 1914, at which I had the good fortune to be present,<sup>1</sup> a good amount of digging has been done by irresponsible persons, and this can be seen from the considerable enlargement of one of the trenches which were dug during that time. We have been assured, moreover, that many bones from the cave have been recently sold to several persons of the locality and to many others who are only affected by the craze of collecting.

For the present excavations Mr. C. Rizzo, P.A.A., who is undoubtedly one of the best authorities on the geology of these islands, suggested that some digging should be done around a large stalagmite 115 feet from the entrance and about 10 feet from the left side of the cave, in the hope that it might have served to obstruct the way to carcasses which the flood may have once washed inside, and to see also if stalagmite has been found on any of the animal remains.

Taking up this suggestion, a trench from 5 to 6 feet wide was dug along the whole width of the cave, which at this point is 30 feet wide.

The roof over the part where the present trench was dug contains two groups of stalactites, one on each side, those in the middle having been detached, as can be seen from the parts of them still adhering to the roof, upon which stalactitic formations are again appearing. Mr. Rizzo observed that the stalactites are all formed below fissures of the rock.

The larger of these groups is the one towards the left side, and several of the stalactites composing it are as much as 3 feet in length and nearly 2 feet in diameter; to one of these corresponds the large stalagmite, which is 5½ feet high and 2½ feet in diameter. The top of this stalagmite projected for over one foot over the surface of the cave earth, and this projecting part is probably one of the large semi-circular bosses alluded to by Cooke, and which he describes as 'bases of stalagmites.'

The superficial layer consisted of rounded boulders, many of which

<sup>1</sup> *Man*, Jan. and Feb. 1916, Nos. 1, 14.



were as much as  $1\frac{1}{2}$  or 2 feet in diameter: the greater part of these was heaped up to a height of about 3 feet along both sides of the cave; the middle part, around the large stalagmite, must have been cleared of them, evidently to form the pathway which runs inwards from the mouth of the cave to a distance of over 200 feet. Among the boulders both pottery and organic remains were found; the former consisted chiefly of sherds of various textures, the majority being very rough and poorly baked, and several of them were as much as three-quarters of an inch in thickness; the latter consisted of lumps of seaweed (*Posidonia oceanica*), which is often used here even at the present day for bedding for cattle instead of straw, and of limb bones, vertebræ, and jaws of cow, pig, and sheep or goat. These bones were, however, so very friable that they would not suffer the least handling, and, with the exception of the crown of some of the molars, all crumbled to dust as soon as touched.

All the boulders having been cleared away, the surface of the cave earth was laid bare before us, so that we could begin digging the second layer, upon which many land shells (*Helix aspersa*) were strewn.

This layer varied in depth from 1 to  $1\frac{1}{2}$  feet; it consisted chiefly of small stones, none of which was over 4 inches in its greatest dimension; these were embedded in a very fine earth of a deep brick-red colour. The organic remains met with in it consisted of some roots and the remains of cow, pig, horse, and sheep or goat. The majority of these bones were in a very fragmentary state; none of them, however, were so friable as those met with amongst the boulders in the superficial layer. The only remains of the horse consisted of a molar which was found close to the large stalagmite, at a depth of  $\frac{1}{2}$  foot from the surface. The remains of the stag were met at the very bottom of this layer, and they consisted chiefly of limb bones, jaws, vertebræ, and a few broken antlers; these last were very much like our globigerina limestone, both in colour and consistency. Land shells were also met with in this layer, but only towards the right side of the cave; these consisted mostly of *Helix vermiculata* and *Rumina decollata*, a few *Helix Caruanæ*, one or two *Helix aperta*, a *Helix cellaria*, a *Cyclostoma melitense*, and a few *Clausilia bidens*. We also noted many fragments of land shells which it is quite impossible to identify. The pottery met with in this layer consisted of sherds of various texture, mostly belonging to the neolithic period.

The next or third layer consisted of a very fine red earth with hardly a single stone in it; it contained, however, many broken stalactites, varying in length from only a few inches to two or three feet, and in diameter from one-eighth or one-sixth inch to nearly one foot. They lay at different depths in this layer, which in some parts was as much as 3 feet thick. Many of these stalactites, which had evidently been detached from the roof just above, must have been lying in the position in which we found them for a considerable time, as was clear from the stalagmites which were subsequently found above them, and which in some cases were as much as one foot in height.

Two large stalactites covered with a very thick stalagmitic formation, which had fallen from the part of the roof just above, as

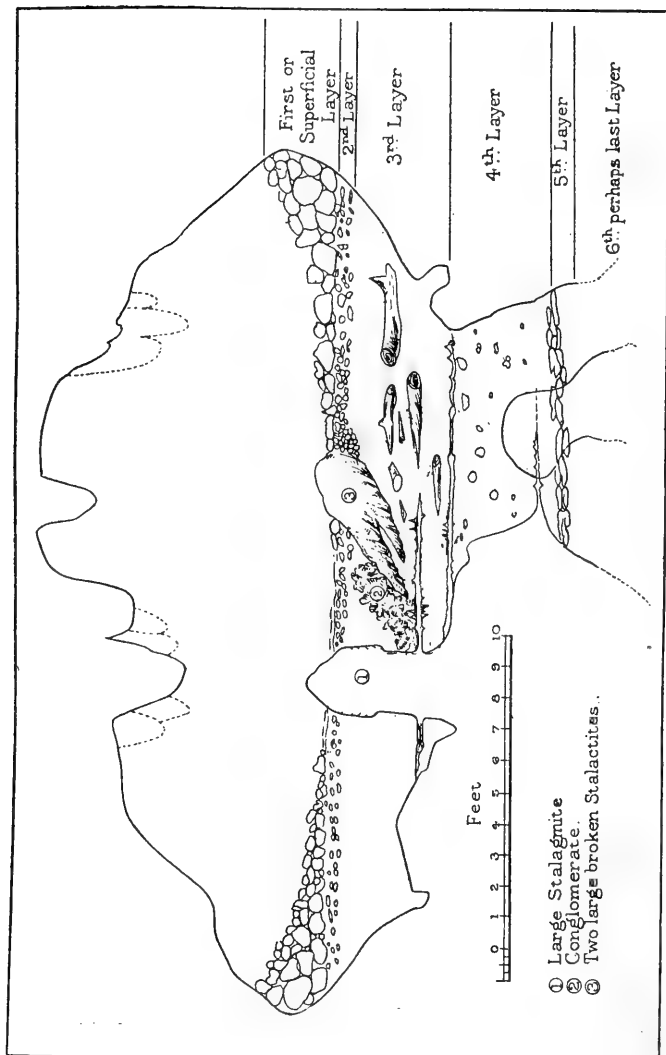

seen from their parts still adhering there, lay in a slanting position, embedded midway into this layer, through all the foregoing and projecting for over one foot over the surface. These stalactites we shall call 'the large broken stalactites.' The organic remains found in this layer were as follows. Just at the top of it human remains were met with; these consisted of four phalanges, a metacarpal bone, a milk molar, and one of the first bicuspid. Land shells were also met with in abundance at this level and a little further down: the majority of them were much fractured, and all of them so friable as to be very difficult to extract. I managed, however, to obtain seven or eight nearly perfect specimens. I compared these with those met with by Cooke when he excavated this cave, and I found them quite different. In size these shells (fig. 1a) are equal to the *Helix vermiculata*; in shape, however, they are identical with the *Helix melitensis* (fig. 2a).

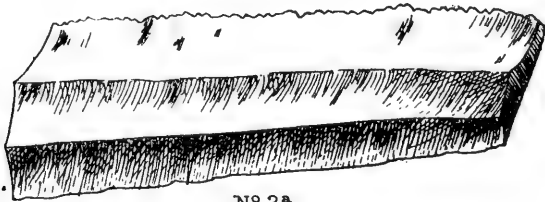
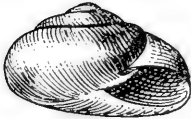
N° 3<sup>a</sup>N° 1<sup>a</sup>N° 2<sup>a</sup>

NAT. SIZE.

This struck me so much that I asked the opinion of my friend the Contino Dr. R. Caruana Gatto, who is the first authority on the land shells of these islands, and he considers them to be a new undescribed variety which he denotes as *var. Despottii*. Besides the land shells three marine species were met with; these consisted of the upper four or five whorls of a *Triton nodiferum*, a broken *Murex trunculus*, and an *Euthria cornea*. These were of the colour and consistency of chalk, and, though rather far from one another, were found at a uniform depth of 3 feet or so from the surface—*i.e.*, in the middle of the present layer.

Stag remains were found in considerable quantities almost all through this layer. Between the two large broken stalactites and the large stalagmite there was a conglomerate of stalagmitic formations and stag bones; this was in some places over 2 feet thick.

Between the large stalagmite and the left side of the cave small

bones, probably belonging to mammals the size of a rat, were found in great abundance, and they were met with from the very surface of this layer down to a depth of 3 feet; with them a few avian remains were also found. Both these and the foregoing, however, will have to be sent for identification, together with some other doubtful specimens, to the specialists of the British Museum, who are always so kind as to offer us their valuable aid.

The inorganic remains consisted of a fine flint knife (fig. 3a), which was found at the same level with the human bones; potsherds were also met with until about the middle of this layer, where two sling stones were also found. The sherds were of various textures, some being rough; others, on the contrary, rather fine, and having a fine slip; some had even ornaments engraved upon them, and these, according to Professor Zammit, who is our most competent authority on the subject, belong to the bronze age.

At a depth of nearly two feet from the surface of this layer a stalagmitic incrustation varying in thickness from a half to one-eighth of an inch projected circularly from the sides of the large stalagmite to a distance varying from two to four feet. Stag bones were found beneath it, and these were of a peculiarly dark colour; the earth here was also blackish, but it continued so from the very surface of the cave floor. This might be due to the excrement of bats, which congregate in great numbers between the large stalagmites just above.

A little more than one foot further down than this incrustation another one similar to it, but somewhat thicker and extending to a greater length, was found broken for the greater part; this is very probably due to the fall of the two large broken stalactites.

Just beneath this stalagmitic formation came the next, or fourth, layer; this was composed of red earth, having only a few stones sparingly scattered through it. The animal remains met with in it were stag bones, the most abundant parts of which consisted of fragments of antlers, belonging to animals ranging from the fawn to full-grown individuals; so abundant, in fact, were these antlers that it is difficult to explain why the number of other bones found together with them is so comparatively small.

The bones found close to the rock from which the large stalagmite rises are of a black colour, the majority being very heavy, and almost of the consistency of pebbles. A foot from the bottom of this layer a third stalagmitic formation projects out of the rock towards the right side of the cave; this had to be broken away, and beneath it the bones met with were of a charcoal-black colour, and still heavier than those met with just above. A few bits of these bones were of a reddish-brown colour, and their consistency was almost like that of flint. The majority of these bones were broken and rounded, showing evident signs of their having been rolled considerably. Close to the rock on the right side, at a level with this last incrustation, a part of an elephant's molar (*E. mnaidrensis*) was found. This, too, is very much worn by rolling; its colour, however, is not dark.

The fifth layer consisted of flat angular stones larger than any yet met with, excepting those in the superficial layer. Many pieces of

stalagmitic formations and stalactites were embedded between them, and the whole was conglomerated by a loamy red earth, mingled with whitish dust and bits of clay. The animal remains met with in this layer consisted of a few stag bones.

We come now to the sixth layer, which may be the last. Its depth cannot yet be given, as it still continues further down; four feet or more of it have, however, already been excavated. It is difficult to give a good account of this layer, as, properly speaking, there is no stratification in it. On one side we find pure clay, on another we find dust and coarse sand intermingled with it; in some parts we meet again with the usual red earth, which at this level is rather clayey, and so on.

In this layer the remains of the two hippopotami (*Hip. penlandi* and *H. minor*) appeared; with them, however, were associated the remains of elephants (*E. mnaidrensis*) and stags.

The remains of the hippopotami and elephants which can be well identified consist chiefly of molars and tusks; those of the stags of fragments of antlers. The other bones are in such a fragmentary state that no more can be said about them than that they belong to either the hippopotamus or to the elephant. They are very black, very heavy, and much rounded, and at first sight rather difficult to distinguish from the pebbles with which they are also associated. The pebbles here are of various colours and consistency, and very much like the pebbles found all along the beach of Marsascirocco harbour; with them some bits of stalactites are to be met with; these, too, are perfectly rounded, showing that, like the bones, they have undergone a good deal of rolling about. Among these pebbles, the majority of which are not more than four inches in diameter, some rounded boulders of very hard stone were met with, some of these being as much as  $1\frac{1}{2}$  foot in diameter.

This is, of course, only a preliminary report on the animal remains found during these excavations, and as they consist of several thousands of bones, it is quite clear that a considerable time is required for the compilation of a detailed report. The want of specimens for comparison is also to be taken into consideration, as well as the fact that consequently some of the specimens will have to be sent to the British Museum for identification. Amongst these species hitherto unknown in this locality might also be found.

The most important fragments of pottery found during these excavations were the following:—

(1) A sherd of a reddish and poorly baked clay having two lines very roughly incised upon it; its thickness is nearly  $\frac{3}{4}$  inch, and it was found at  $1\frac{1}{2}$  foot from the surface.

(2) Another fragment of a blackish and red colour, having a slip on the inside and on the outside a line of very coarse ornaments, probably done by means of the thumb nail. The thickness is the same as that of (1), but (2) was found one foot lower down.

(3) A fragment of very poorly baked clay having bits of shells in it; the inside is very rough and of a blackish colour on the outside; however, there is a thin coating of a buff colour, which seems to be of

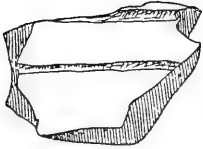

1

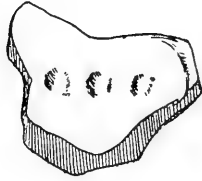

2

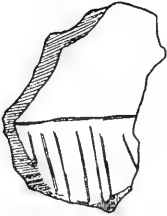

3

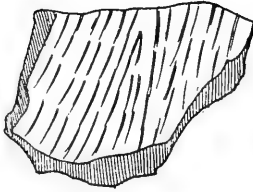

4



5



6

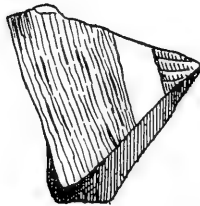

7

HALF NAT. SIZE.

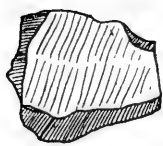

8

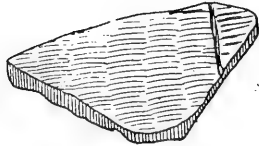

9

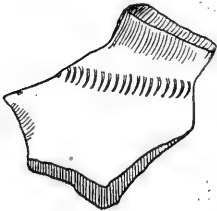

10

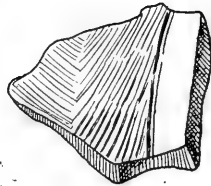

11



14

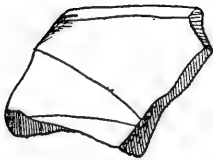

12



13

HALF NAT. SIZE.

finer texture. Some incision may also be seen upon it; its thickness is  $\frac{1}{2}$  inch. It was found at a depth of 1 foot from the surface.

(4) A very rough sherd  $\frac{1}{2}$  inch in thickness, and having many fragments of shells in it; on the inside it is of a reddish colour and on the outside black. Upon the black, however, it has a very thin coating of buff colour. The incisions on it are rather coarse, and are apparently made by means of the finger nail. It was found at a depth of 3 feet from the surface.

(5) A fragment of the same texture as the foregoing, wanting, however, the buff coating, and having more coarse incisions upon it. It was found at a depth of  $2\frac{3}{4}$  feet from the surface.

(6) A very rough and poorly baked sherd of a slate colour, having a perfectly black coating on the inside; the ornaments incised upon it, though more elaborate, are also coarse. Its thickness is a little more than  $\frac{1}{4}$  inch; it was found at a depth of  $2\frac{1}{2}$  feet.

(7) Another fragment of a very rough texture; its colour is a slate grey, and it has a more elaborate ornament engraved on it. Its thickness is about  $\frac{1}{2}$  inch, and it was found at a depth of 2 feet from the surface.

(8) A bit of very poorly baked pottery  $\frac{1}{2}$  inch thick, having rather coarse incisions upon it; it is also of a slate-grey colour, and was found at a depth of 3 feet.

(9) A fragment of pottery of a slate colour, having a perfectly black coating on the inside. The greater part of the incisions on it are rather faint, but it has also a band of a well-marked ornament. Its thickness is  $\frac{1}{4}$  inch, and it was found at a depth of 3 feet from the surface.

(10) A fragment of much better baked pottery of finer texture; it is probably a part of a bowl; it has a fine band engraved around it, which is probably made with the finger nail. In colour it is grey, with a black coating on the inside. Its thickness is  $\frac{1}{4}$  inch, and it was found at the same level with (8) and (9).

(11) This is similar in texture to No. 8; the incisions on it are, however, finer. It was found a little higher up than Nos. 8, 9, and 10.

(12) This sherd is of almost the finest quality met with during these excavations. Its colour is black, with a reddish slip on the outside. It is a fragment from the rim of a vase; the incisions upon it are fine and straight. Its thickness is less than  $\frac{1}{4}$  inch, and it was found at a depth of 2 feet from the surface.

(13) A sherd of very rough texture, very poorly baked. In colour it is dark grey, with a whitish slip on the outside. The ornaments upon it consist of two incised parallel lines; it is  $\frac{1}{3}$  inch in thickness, and it was found at a depth of only  $\frac{1}{2}$  foot from the surface.

(14) This is undoubtedly the finest piece of pottery found during the excavations. It is of a black or very dark-grey colour; its thickness is less than  $\frac{1}{8}$  inch; the incisions upon it are also more perfect than any of those on the foregoing sherds. They are filled with a material quite like chalk, both in colour and consistency. This sherd was found at a depth of a little over 3 feet from the surface.

---



*Artificial Islands in the Lochs of the Highlands of Scotland.—*  
*Report of the Committee, consisting of Professors BOYD*  
*DAWKINS (Chairman), J. L. MYRES (Secretary), T. H.*  
*BRYCE, and W. RIDGEWAY, Dr. A. LOW, and Mr. A. J. B.*  
*WACE, appointed to investigate and ascertain the Distribu-*  
*tion thereof.*

*Excavation Work on the Crannog in Loch Kinellan, Strathpeffer.*  
*Report from HUGH A. FRASER, M.A.*

As mentioned in the 1913 Report of this Sub-Committee, a grant was made by the Carnegie Trust to Dr. Munro for the excavation of the island in Loch Kinellan. In August 1914 Mr. Hugh A. Fraser started work on the island, with the assistance at the outset of the Rev. Odo Blundell and later of Dr. Munro.

The work done in 1914 established the island as an artificial one, a point on which there was previously some doubt.

Pits dug over the surface of the crannog revealed in every case a platform of logs or brushwood, or compact occupation-débris, underneath a superincumbent mass of earth, clay, and stones, some four feet thick.

Unfortunately, digging was greatly interfered with by water percolating through the structure of the island from the loch. This not only delayed the work, but caused additional labour which exhausted the grant before the work had reached anything like a conclusive stage.

Persuaded that more could be gleaned from a careful examination of the pits than was learned in 1914, I started work again in 1915.

On examining the woodwork with care I found quite a number of logs with checks, mortise-holes, &c. In no instance, however, did the most careful examination reveal these checks and mortise-holes as serving any primary purpose. Everything drove one to the conclusion that part at least of the wood used for strengthening the structure of the island had previously been employed for some other purpose.

At the east end of the island the overlying mass of earth and stones appears to rest on a platform of brushwood; in the centre and at the west end it rests on wooden platforms. Two pits at the east end, dug to the base of the island, showed underneath the surface-material successive layers of occupation-débris right down to the original lake bottom, some seven feet below the present surface. In selected pits situated at the centre and west end of the island the wooden platforms were pierced, and were found to consist of three layers of logs or tree-stems. Underneath the platforms there seems to be a succession of layers of habitation-débris corresponding to those found at the east end of the island.

In course of the excavations, bones, whole and broken, and other kinds of food-refuse, were found in profusion, as were also pottery shards in the upper strata. The bones have been examined and reported on by Professor Bryce of Glasgow University, while the pottery has been reported on by Mr. Curle, Director of the Royal

Scottish Museum. The pottery is at present being compared with the pottery found in the Glastonbury lake-dwellings.

The archæological relics include a number of stone implements, one or two whorls, and an ivory playing piece.

Late in the season a dug-out canoe was discovered supporting the logs in one of the pits. A length of twenty feet was exposed when the late autumn floods stopped work for the year.

From the point of view of structure the results obtained have been interesting, and if continued may prove very valuable archæologically. Any approximation as to the date of the island, or to the dates of its various eras, can only be made after careful comparison of the results obtained with those got at other sites—work that involves much labour and time. While further work on the island is very desirable, such work, to be of value, must be on a more ambitious scale than the funds available have hitherto permitted.

The facts that continuous layers of occupation-refuse exist right down to the original bed of the lake and that much of the woodwork overlying these layers and supporting the surface-material shows signs of having been previously used structurally would point to the site's having been originally the location of a pile dwelling or palifite, the débris from which formed the basis of the more modern crannog. While this suggestion is made tentatively, the theory was not sought for, but was arrived at as a possible and a very probable explanation of many circumstances noted in course of the investigation.

---

*The Structure and Function of the Mammalian Heart.—Report of the Committee, consisting of Professor C. S. SHERRINGTON (Chairman), Professor STANLEY KENT (Secretary), and Dr. FLORENCE BUCHANAN, appointed to make further Researches thereon. (Drawn up by the Secretary.)*

THE work of the Committee since the date of the last Report<sup>1</sup> has progressed slowly, owing to numerous interruptions which have occurred. The Secretary was for some time engaged in the training of officers for the new armies. Afterwards he devoted the whole of his time to an inquiry into industrial fatigue. Under the circumstances it was thought best to devote such time as was available to the preparation of material and the accumulation of facts rather than to attempt the publication of any detailed statement of results. The work that has been done is satisfactory, and will greatly assist future progress.

The Committee ask to be reappointed with a grant of 50*l*.

<sup>1</sup> *Annual Report, 1915, p. 226.*

---

*The Ductless Glands.*—*Report of the Committee, consisting of Professor Sir EDWARD SCHÄFER (Chairman), Professor SWALE VINCENT (Secretary), Dr. A. T. CAMERON, and Professor A. B. MACALLUM. (Drawn up by the Secretary.)*

THE work of the Committee has been carried on during the past year by the Secretary and by Messrs. Austmann and Halliday under his direction.

The subjects of investigation have been the effects of prolonged anæsthesia on the adrenalin content of the blood, and the morphological position of the islets of Langerhans in the pancreas.

The results are generally confirmatory of previous work on the subject, but they involve questions of detail in technique which will be more appropriately described elsewhere.

The Committee ask to be reappointed with a grant of 25l.

*Electromotive Phenomena in Plants.*—*Report of the Committee, consisting of Dr. A. D. WALLER (Chairman), Mrs. WALLER (Secretary), Professors J. B. FARMER, T. JOHNSON, and VELEY, and Dr. F. O'B. ELLISON.*

THE object of the work this year has been to determine whether, for the practical purpose of 'seed germination testing,' if the whole seed be used a sufficiently strong electrical response is obtained.

The extraction of the radicle in small seeds is a delicate and troublesome process, so that it would be an advantage to be able to use the whole seed.

The following table shows the difference in response of the whole pea intact and its radicle:—

PEAS SOAKED TWENTY-FOUR HOURS.

1. Whole pea blaze	. . . . .	·0070	volt.
Its radicle	. . . . .	·0350	„
2. Whole pea	. . . . .	·0125	„
Radicle	. . . . .	·0350	„
3. Whole pea	. . . . .	·0050	„
Radicle	. . . . .	·0300	„
4. Whole pea	. . . . .	·0110	„
Radicle	. . . . .	·0400	„
5. Whole pea	. . . . .	·0160	„
Radicle	. . . . .	·0200	„
6. Whole pea	. . . . .	·0100	„
Radicle	. . . . .	·0250	„

*Experimental Studies in the Physiology of Heredity.*—Report of the Committee, consisting of Professor F. F. BLACKMAN (Chairman), Mr. R. P. GREGORY (Secretary), Professors W. BATESON and F. KEEBLE, and Miss E. R. SAUNDERS.

THE experiments have been carried on during the present year in spite of labour difficulties.

The work on *Primula sinensis* has mainly devolved on Miss Killby, Captain Gregory having been occupied with military duties. The seed harvest in 1915 was a large one, and it has been necessary to hold over some of the material to be dealt with in the coming season. The results already obtained have added considerably to our knowledge of the genetics and cytology of the peculiar (tetraploid) races which contain double the normal number of chromosomes. Some of these races produce types which in the form of leaves and corolla and in certain colour characters find no parallel among the races with the normal number of chromosomes ('Proc. Roy. Soc.,' December 1915). Progress has been made with the work of fixing certain types which have not as yet bred true, and in the course of the work a new form has been produced, the existence of which had been predicted though it had not previously been obtained.

Miss Killby has also continued her work on beans and marrows, but two unfavourable seasons have delayed the work, and a further crop of plants will have to be raised before any definite statement can be made.

Miss Gairdner has continued her experiments with wallflowers, but the work is not yet complete.

Miss Saunders has carried out further work on stocks, foxgloves, and lobelia.

From the new stock, intermediate in surface character between the ordinary fully hoary type and the wallflower-leaved variety obtained last year, another new form has been bred, intermediate again between its parent and the glabrous form. The gap between the two extreme types is thus being gradually bridged, and it is hoped that the production of these new forms may furnish a clue to the curious and unexplained relation between surface character and sap colour. Progress has been made with the attempt to synthesise an eversporting form, but further generations will need to be raised before any definite result can be expected.

Of foxgloves a considerable number of first-year plants have been grown, and it is hoped that they will yield important results next year. In the meanwhile they are being utilised as far as possible for the supply of digitalin.

It is expected that the results obtained this year with lobelia will complete the work on the inheritance of doubleness in that form.

It is hoped that it will be found possible to renew the grant, as a number of the experiments are still in progress.

---

*The Renting of Cinchona Botanic Station in Jamaica.—Report of the Committee, consisting of Professors F. O. BOWER (Chairman), R. H. YAPP (Secretary), R. BULLER, F. W. OLIVER, and F. E. WEISS.*

THE diminished rent of 12l. 10s. was duly paid to the Jamaican Government and acknowledged. Owing to the continued state of war, no student made use of the station during the year.

Following on the letter from the Colonial Secretary, printed in the 1915 Report, the Jamaican Government have now entered into correspondence with Professor Duncan Johnson, of Baltimore, with a view to a lease from October 1, 1916, and with a provision that it should be made free to botanists of both countries (see letter of Assistant Colonial Secretary, March 21, 1916). In the latest communication (see letter of Acting Colonial Secretary, June 8, 1916), Mr. Cousins adds: 'That it is now suggested that Johns Hopkins or Cornell Universities may consent to act in the matter of the lease, and that this may start from October 1 next, when the British Association tenancy would end.' It is also added that the Jamaican Government 'will negotiate for a free admission of British botanists as desired,' and that we shall be informed later of any arrangements made.

As it thus appears that the British Association will obtain the object desired, viz., the accommodation of students at the Cinchona Station without any payment at all, the Committee ask that they be reappointed for the purpose of receiving applications from students; but they do not apply for any renewal of grant.

*Mental and Physical Factors involved in Education.—Report of the Committee, consisting of Dr. C. S. MYERS (Chairman), Professor J. A. GREEN (Secretary), Professor J. ADAMS, Dr. G. A. AUDEN, Sir E. BRABROOK, Dr. W. BROWN, Mr. CYRIL BURT, Professor E. P. CULVERWELL, Mr. G. F. DANIELL, Professor B. FOXLEY, Professor R. A. GREGORY, Dr. C. W. KIMMINS, Mr. W. McDougall, Professor T. P. NUNN, Dr. W. H. R. RIVERS, Dr. F. C. SHRUBSALL, Professor H. BOMPAS SMITH, Dr. C. SPEARMAN, and Mr. A. E. TWENTYMAN, appointed to inquire into and report upon the methods and results of research into the Mental and Physical Factors involved in Education.*

#### *Norms in Mechanical Arithmetic.*

THE Committee has had under consideration the question of so-called 'normal performances' of school children. It would be of great service to teachers to determine what may be considered reasonable

requirements from children of particular ages. In regard to most attainments such determinations present problems of great complexity. Individual children vary greatly in their powers and in the circumstances of their out-of-school lives. So far as it is the outcome of experience, knowledge can hardly be measured; and there is by no means a general agreement about what ought to be taught to children of eight or to children of eleven. In the case of the fundamental instruments of social intercourse the problem is simpler. The mastery of these is generally expected as a result of school training; progress in these is more or less steady throughout the school career. Arithmetic, reading, spelling, and writing provide instances. Arithmetical skill is largely dependent upon the rapid and accurate use of the fundamental processes—addition, subtraction, multiplication, and division—which function best when they have reached the level of mechanical habit. In reading and writing mechanical habit again plays a chief part in their efficient use. But these subjects are psychologically more complex; and it is disputable whether any real value can come from isolating the ‘habitual’ elements and attempting to measure progress in the development of mere mechanism. In the case of the arithmetical habits, no such disadvantage arises. Accordingly, the Committee has restricted its inquiries to the four ‘fundamental rules’ of arithmetic—addition, subtraction, multiplication, and division.

#### *General Principles.*

In constructing test-sheets for each kind of process a definite, written scheme has been followed. Consequently, for the same kind of test it is possible to construct any number of test-sheets of approximately equal difficulty.

As far as possible, all the available figures and combinations of figures in pairs are used with equal frequency. The tests are so constructed that any child, after working through the first quarter (or in some tests, half) of the paper, has worked through all possible pairs of numbers (up to 9) once each. And, as far as possible, the pairs are scattered over the paper by pure chance. Every other column for addition sums involves ‘carrying.’ Similarly, half the pairs for subtraction involve ‘borrowing.’ No ‘remainders’ are involved in the division sums. To facilitate computation of marks the sums were printed in rows of five or ten. One mark was awarded for each correct operation,—each column correctly added, each pair of figures correctly subtracted, multiplied, or divided.

The children worked the sums upon sheets already printed. The tests were set, timed and marked by the investigators themselves or under their immediate superintendence.

#### *London Schools.*

Four elementary schools were chosen: the boys’ department of an ordinary school attended by children in a ‘good’ neighbourhood; the girls’ department of an ordinary school in a ‘poor’ neighbourhood;

the boys and girls of an ordinary mixed school in a 'moderate' neighbourhood; and the boys and girls of the junior mixed and elder (girls) departments of a special school for the mentally defective.

*Numbers.* (Table I.)

In all, 936 'normal' children and 111 'defective' children have been examined in London with the same series of tests (series 11). Taken in isolation, the numbers in some of the age-groups are small. Those above 13 and below 8 years of age are so few, and so highly selected, as to be negligible for general comparison.

*Age-Averages.* (Tables II. and III.)

The results, for the most part, show a steady progress from year to year. The average rate of progress in addition, subtraction, multiplication, and division, is about 3, 5, 7, and  $4\frac{1}{2}$  marks per annum respectively. At 10 years, the children attain on an average 22, 44, 40, and 26 marks: *i.e.*, they work at the rate of 8 or 9 operations a minute in multiplication and subtraction, and at about half that rate in division and addition. At the age of 11 the rate of progress declines; and at 13 the average may even fall. In this decline, an important, but not the sole factor, is doubtless the transference of the best scholars to secondary and central schools. If we assume that, with a complete sample for the higher ages, progress would continue at nearly the same rate, then the following regression-equations would serve to calculate very approximately the norm from the age last birthday:—

Addition-mark	=	$4 \times \text{age} - 18$
Subtraction-mark	=	$8 \times \text{age} - 36$
Multiplication-mark	=	$10 \times \text{age} - 60$
Division-mark	=	$8 \times \text{age} - 54$

*Standard Deviation* (Table IV.) *and Range* (Table V.).

Within each age, the variation of individuals is considerable. The standard deviation increases absolutely with increase of age, but diminishes relatively to the age-average from about half the average to about a third.

The best performance at the age of 9 usually surpasses the average performance at the age of 13; the worst performance at the age of 13 usually falls to the average performance at the age of 8. The best performance in any age-group is double the average for that group, but occasionally may be four or five times as large.

*Overlap of Ages.* (Figure 1.)

Owing to the wide individual variation, the overlap between the several ages in any single test is enormous. The knowledge of the 'norm' or average for a given age, without knowledge of the amount

MARKS

Z  
U  
B  
T  
R  
A  
C  
T  
I  
O  
N

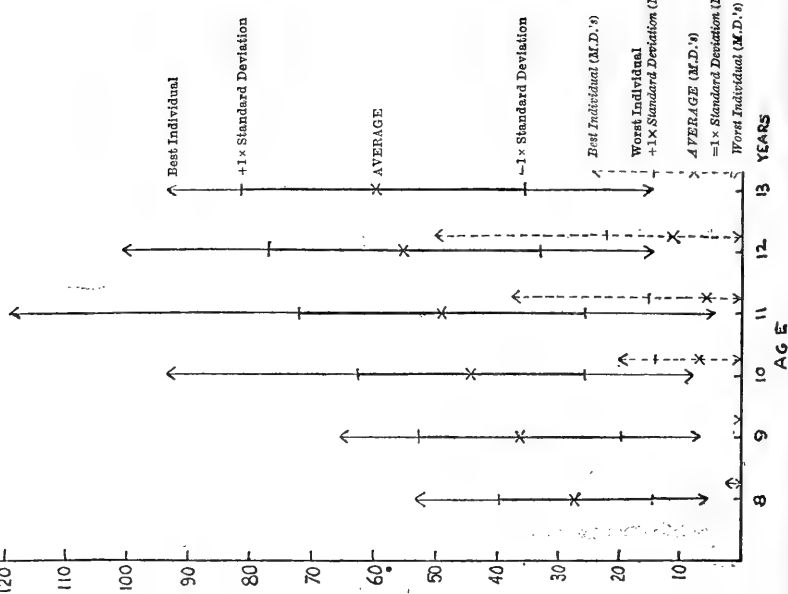

MARKS

A  
D  
D  
I  
T  
I  
O  
N

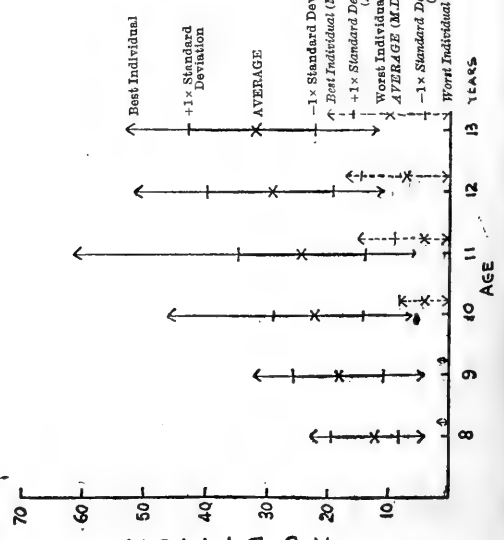



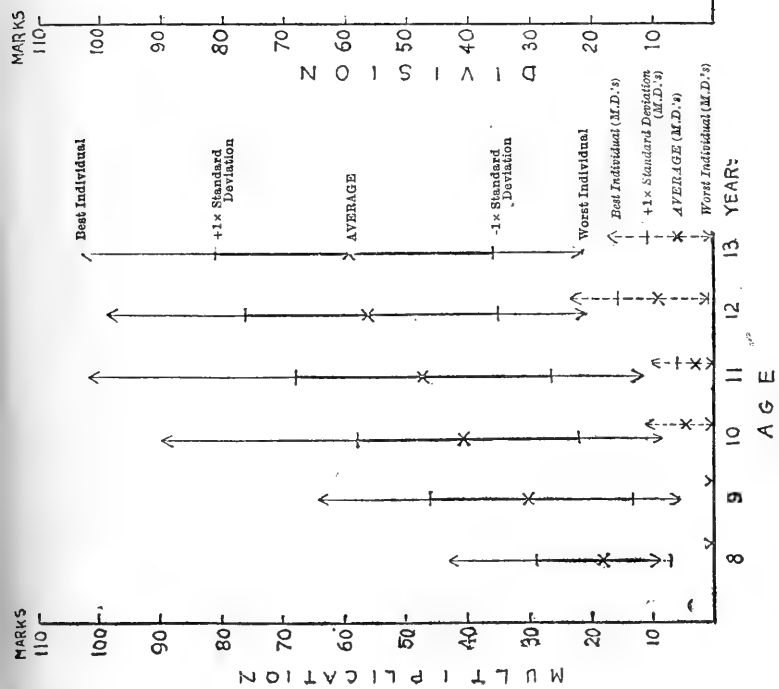

Figure 1.—Average, Standard Deviation, and Range for each Age-Group in Schools 'G,' 'M.(B.),' 'M.(G.),' 'P.,' and 'M.D.'

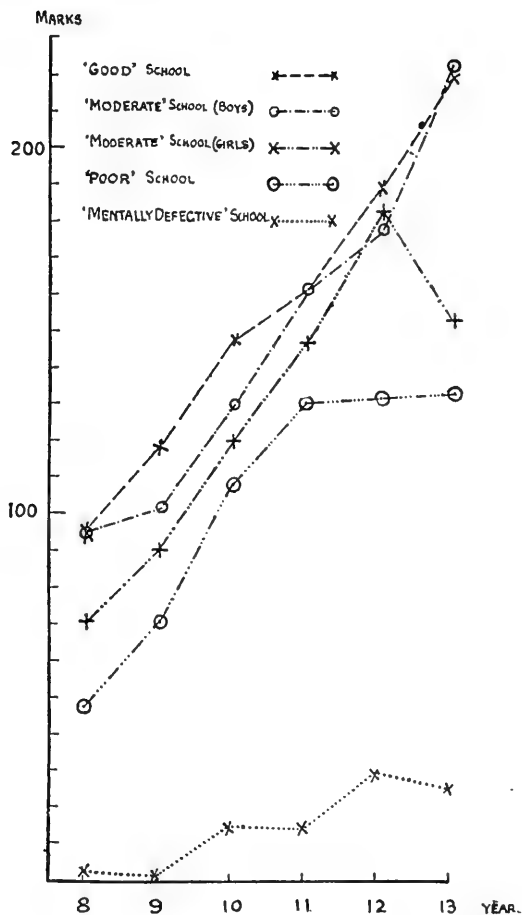

FIGURE 2.—Averages for the several Ages in the several Schools (Marks for all Tests).

of deviation around that average, is thus of little value. In consequence, however, of the incomplete, though high, correlation between performances in the several tests (Table VII.) and the high correlation with age, the overlap in the totals for the tests is smaller than the overlap in each test taken singly.

#### *Sex and Social Status.* (Table V.)

The children in the 'Good' school gain about 50 per cent. more marks than the children in the 'Poor' school, despite the fact that especial care is taken with the teaching of mechanical arithmetic in the latter. In the 'Moderate' school the average marks as a rule fall between those gained at the 'Good' and 'Poor' schools respectively. Except at 12, the averages of the boys in the mixed school surpass those of the girls in every age.

#### *Defectives.*

Even in the highest and largest age-group (age 12), the averages for the defectives are less than half those for the normal children of the age of 8. Roughly, they appear to be backward by nearly half their age; and deviate below the average for their age by nearly three times the standard deviation.

There is often, however, an appreciable overlap (Figure 1). In nearly every ordinary school tested there are performances which are worse than the best found among defectives of the same age.

#### *Correlations between the Several Tests.* (Table VII.)

Within each class the correlations between the several tests are moderately high. Within each age-group they would, of course, be enormously higher. No decided hierarchy appears in the averages. There is doubtless a common general factor. But this cannot be mere general ability, since in general ability each class should be nearly homogeneous; and, overlying the general factor, there seem also to be specific factors in cyclic overlap,—multiplication is most closely correlated with division; division nearly as closely with subtraction; subtraction somewhat less closely with addition; addition less closely still with multiplication, and least of all with division.

#### *Sheffield Schools.* (Tables VIII. and IX.)

Four Sheffield schools have worked tests which were built up on the same lines as those used in London, though the actual examples used were different. The four schools included one large mixed school in a neighbourhood rather above the average, a boys' school in an average artisan district, a girls' school in a poor district, and a mixed junior school in a district similar to the first school. There is, however, some difficulty in using these necessarily inexact descriptive terms of

schools in provincial towns where districts are not usually so clearly defined as in London.

Unfortunately, the figures for the four schools are not yet completely worked through. It is hoped to present them at the meeting. In comparison with the London figures, it should be noted that the age groups are larger, the averages are higher, the standard deviations are larger, and the range is wider.

The correlations between the pairs of subjects for School C worked out for the several age groups, although not in detail comparable with those in Table VII., are considerably higher in the general averages at the foot of each column than those for the London schools. It is perhaps worth noting, however, that the correlation between multiplication and division is highest in both tables, and that between subtraction and division is next highest also in both cases.

For the rest, the same generalisations emerge. There is a steady progress from year to year. But the age-differences are swamped by the large variation and wide range exhibited by the individuals of each age-group.

The Committee desires to be reappointed with a grant of 10*l*.

(NOTE.—Tables I.—VII. refer to London schools; Tables VIII.—IX. to Sheffield schools.)

TABLE I.  
*Number of Children Tested.*

Age	'G.' School	'M.' School (Boys)	'M.' School (Girls)	'P.' School	Total Ordinary	'M.D.' School	Total All Schools
16-						3	3
15-	1	1			2	15	17
14-	8	3	1	1	13	8	21
13-	47	12	12	31	102	25	127
12-	42	15	37	34	128	28	156
11-	79	21	25	35	160	15	175
10-	101	33	38	36	208	6	214
9-	97	28	34	39	198	4	202
8-	42	11	8	36	97	6	103
7-				27	27	1	28
6-				1	1		1
Total	417	124	155	240	936	111	1,047

TABLE II.  
Averages in the Several Tests for each Age-Group.

Age	ADDITION						SUBTRACTION				
	'G.' School	'M.' School (Boys)	'M.' School (Girls)	'P.' School	'M.D.' School	'G.' School	'M.' School (Boys)	'M.' School (Girls)	'P.' School	'M.D.' School	
16-					6.6					1.7	
15-	22.0	43.0			9.2	25.0	47.0			2.7	
14-	25.6	44.0	36.0	40.0	7.7	59.6	71.7	77.0	71.0	4.2	
13-	36.8	37.2	24.2	28.0	9.7	69.3	63.0	38.4	47.1	7.8	
12-	30.5	37.6	28.1	25.8	6.9	57.6	51.6	55.6	53.5	11.0	
11-	26.0	27.5	21.5	19.9	4.1	51.1	48.7	46.0	46.7	5.4	
10-	23.8	22.0	19.5	17.2	4.0	47.7	40.8	39.2	41.6	6.8	
9-	20.8	17.0	14.7	14.5	0.7	40.0	33.8	30.2	29.6	0.0	
8-	16.9	14.3	12.5	10.3	0.7	33.2	29.9	21.7	20.3	0.7	
7-				6.0	0.0				10.3	0.0	
6-				5.0					1.0		
Average (ages 8- to 13-)	25.8	25.9	20.1	19.3	4.3	49.8	46.6	38.5	39.8	5.3	

TABLE II.—continued.  
Averages in the Several Tests for each Age-Group.

Age	MULTIPLICATION						DIVISION								
	'G.' School	'M.' School (Boys)	'M.' School (Girls)	'P.' School	'M.D.' School	'G.' School	'M.' School (Boys)	'M.' School (Girls)	'P.' School	'M.D.' School					
16-					6.6										
15-	55.0	46.0			10.5	45.0	47.0								2.0
14-	50.4	83.3	82.0	54.0	7.6	44.4	67.0	60.0	45.0						1.8
13-	67.4	70.7	56.2	43.0	5.7	48.4	51.3	34.9	21.1						2.1
12-	58.1	53.3	61.7	48.2	9.0	43.0	37.0	37.4	27.2						2.8
11-	49.2	52.4	47.4	40.0	2.3	35.7	33.6	32.5	23.5						1.3
10-	44.5	45.0	36.1	32.2	4.7	31.6	28.9	26.1	16.4						1.0
9-	34.8	31.6	27.3	17.8	0.0	22.2	19.1	17.8	8.7						0.0
8-	27.4	32.1	21.5	13.3	0.0	17.0	18.7	15.0	3.5						0.0
7-					0.0				1.4						0.0
6-					1.0				0.0						
Average (ages 8- to 13-)	46.9	47.5	41.7	32.4	3.6	33.0	31.4	27.3	16.7						1.2

TABLE III.  
*Average Marks for the Several Tests.*  
*(Ordinary Elementary Schools.)*

(The marks for the several age-groups in the several schools have been weighted according to the number of children in each.)

Age	Addition	Subtraction	Multiplication	Division	All Tests
15-	32.5	36.0	50.5	46.0	41.2
14-	31.8	64.6	61.5	50.8	49.7
13-	31.7	58.2	59.0	39.1	47.0
12-	29.4	54.9	56.0	37.3	44.4
11-	24.0	48.8	47.3	32.3	38.1
10-	21.6	44.0	40.3	27.1	33.2
9-	18.1	36.1	29.9	13.4	24.4
8-	13.8	27.1	18.1	12.2	17.8
7-	5.9	10.3	7.6	1.4	6.3
6-	5.0	1.0	1.0	0.0	1.7
Average (ages 8- to 13-)	23.1	44.8	41.8	26.9	34.1

TABLE IV.  
Standard Deviations in the Several Tests for each Age-Group.

Age	ADDITION								SUBTRACTION				
	'G,' School	'M,' School (Boys)	'M,' School (Girls)	'P,' School	Average (Weighted)	'M.D,' School	'G,' School	'M,' School (Boys)	'M,' School (Girls)	'P,' School	Average (Weighted)	'M.D,' School	
16-						8.0						1.3	
15-	0.0	0.0				7.4	0.0	0.0				2.0	
14-	11.0	10.8	0.0	0.0		5.6	28.7	19.3	0.0	0.0		2.6	
13-	11.2	11.3	8.3	11.1	10.8	5.9	23.3	18.0	13.8	28.2	23.1	6.5	
12-	9.1	14.9	11.0	9.5	10.4	7.7	22.2	20.9	21.3	23.3	22.1	10.8	
11-	10.5	16.2	5.4	10.5	10.4	4.7	24.9	29.9	13.4	20.8	23.0	9.6	
10-	6.7	9.1	7.6	7.9	7.4	4.0	20.6	16.1	19.5	17.2	18.6	7.5	
9-	8.7	4.0	6.6	6.1	7.2	0.9	18.1	11.8	16.6	15.2	16.4	0.0	
8-	6.3	3.6	3.8	6.0	5.6	0.7	13.7	9.3	10.2	12.8	12.5	1.1	
7-				5.0		0.0				6.4		0.0	
6-				0.0						0.0			
Average (ages 8- to 13-)	8.8	9.8	7.1	8.5	8.7	4.0	20.5	17.7	15.8	19.5	19.3	5.9	



TABLE IV.—continued.  
Standard Deviations in the Several Tests for each Age-Group.

Age	MULTIPLICATION							DIVISION				
	'G.' School	'M.' School (Boys)	'M.' School (Girls)	'P.' School	Average (Weighted)	'M.D.' School	'G.' School	'M.' School (Boys)	'M.' School (Girls)	'P.' School	Average (Weighted)	'M.D.' School
16-						3.4						0.8
15-	0.0	0.0				7.4	0.0	0.0				1.9
14-	23.1	25.1	0.0	0.0		5.4	22.7	29.0	0.0	0.0		1.1
13-	20.6	23.4	22.4	27.0	23.1	5.1	22.4	16.0	18.4	15.0	18.9	3.5
12-	21.8	16.9	21.2	21.6	21.1	7.1	18.5	16.9	14.1	11.3	15.1	4.8
11-	21.8	24.4	14.8	20.1	20.6	2.9	22.2	31.1	12.2	18.1	20.9	2.1
10-	18.2	18.6	18.6	14.7	17.8	4.3	16.6	13.3	15.2	9.4	14.5	2.2
9-	21.0	13.3	13.0	9.3	16.2	0.0	16.2	9.6	11.8	7.3	12.7	0.0
8-	10.3	11.1	8.6	9.3	10.9	0.0	11.1	6.0	8.7	5.0	8.1	0.0
7				5.8		0.0				2.5		0.0
6				0.0						0.0		
Average (ages 8- to 13-)	18.9	17.9	16.4	17.0	18.3	3.2	17.8	15.5	13.4	11.0	15.0	2.1

TABLE V.  
*Extreme Range in the Several Tests in each Age-Group.*  
*(Best and Worst Performances.)*

Age	ADDITION						SUBTRACTION					
	'G.' School	'M.' School (Boys)	'M.' School (Girls)	'P.' School	Average	'M.D.' School	'G.' School	'M.' School (Boys)	'M.' School (Girls)	'P.' School	Average	'M.D.' School
16-						18-1						3-0
15-	22-22	43-43				20-1	25-25	47-47				6-0
14-	40-8	59-34	36-36	40-40	43·9-29·5	18-1	48-0	90-45	77-77	71-71	71·5-48·2	9-1
13-	59-10	59-17	39-12	54-9	52·7-12·0	20-0	110-9	88-34	68-16	106-0	93·0-14·7	29-0
12-	48-8	67-16	67-11	43-6	56·2-10·5	17-0	108-5	88-22	117-27	88-5	100·2-14·7	50-0
11-	60-3	94-9	28-9	43-0	61·2-5·2	15-0	144-3	162-0	67-14	101-1	118·5-4·5	38-0
10-	45-2	56-11	40-2	44-7	46·2-5·5	8-0	106-2	82-8	83-1	122-21	98·2-8·0	20-0
9-	40-3	27-12	30-0	31-0	32·0-3·7	2-0	84-4	56-22	63-1	59-0	65·5-6·7	0-0
8-	33-8	19-6	17-3	21-0	22·5-4·2	2-0	79-5	52-14	37-2	42-0	52·5-5·2	3-0
7-				24-0		0-0				29-0		0-0
6-				5-5						1-1		

TABLE V.—continued.  
*Extreme Range in the Several Tests in each Age-Group.*  
*(Best and Worst Performances.)*

Age	MULTIPLICATION						DIVISION					
	'G.' School	'M.' School (Boys)	'M.' School (Girls)	'P.' School	Average	'M.D.' School	'G.' School	'M.' School (Boys)	'M.' School (Girls)	'P.' School	Average	'M.D.' School
16-						10-2						3-1
15-	55-55	46-46				27-0	45-45	47-47				6-0
14-	81-3	120-49	82-82	54-54	84.2-47.0	15-1	68-5	108-46	60-60	45-45	70.2-39.0	3-0
13-	111-21	114-34	86-23	103-6	103.5-21.0	22-0	105-6	71-11	74-12	60-0	77.5-7.2	17-0
12-	101-15	94-34	111-23	88-11	98.5-20.7	23-0	78-16	69-8	79-17	46-7	68.0-12.0	19-0
11-	108-11	140-22	77-17	82-0	101.7-12.5	10-0	103-6	166-0	66-13	75-0	102.5-4.7	6-0
10-	80-7	108-13	91-4	79-9	89.5-8.2	11-0	62-2	61-4	62-0	35-0	55.0-1.5	6-0
9-	82-0	71-21	66-0	38-0	64.2-5.2	0-0	76-2	46-6	50-0	27-0	49.7-2.0	0-0
8-	57-10	48-20	28-4	38-0	42.7-8.5	0-0	44-2	28-4	29-2	19-0	30.0-2.0	0-0
7-				26-1		0-0				11-0		0-0
6-				1-1						0-0		

TABLE VI.

*Total Marks (All Tests) for the Several Schools.*

Age	'G.' School	'M.' School (Boys)	'M.' School (Girls)	'P.' School	'M.D.' School
16-					16.9
15-	147.0	183.0			24.2
14-	180.0	266.0	255.0	210.0	20.6
13-	219.8	222.2	153.7	139.8	25.3
12-	189.3	179.5	183.8	132.4	29.7
11-	161.5	162.2	147.0	130.1	13.1
10-	147.6	129.9	120.9	107.9	16.5
9-	117.8	101.6	90.2	70.6	0.7
8-	95.1	95.0	70.7	47.8	1.4
7-				25.3	0.0
6-				7.0	
Average (ages 8- to 13-)	155.2	148.6	127.7	104.8	14.4

TABLE VII.

*Correlations between the Several Tests.*

Standard	Addition and Sub- traction	Addition and Mul- tiplica- tion	Addition and Division	Subtrac- tion and Multipli- cation	Subtrac- tion and Division	Multipli- cation and Division	Average
VII.A	.40	.55	.58	.77	.61	.79	.617
VII.B	.57	.31	.18	.32	.46	.81	.442
VI.A	.46	.32	.18	.41	.27	.71	.392
VI.B	.55	.51	.46	.58	.55	.49	.523
V.A	.55	.51	.32	.58	.37	.65	.497
V.B	.34	.34	.47	.34	.41	.62	.420
IV.	.29	.47	.16	.32	.62	.70	.427
III.A	.21	.29	.07	.28	.50	.50	.308
III.B	.46	.46	.67	.57	.51	.46	.522
II.	.46	.40	.32	.50	.46	.51	.442
Average	.429	.416	.341	.467	.476	.624	.459

TABLE VIII.

C. (Boys') School.

## I.—Addition (Series 12).

Age . . . . .	8½	9½	10½	11½	12½	13½
Number . . . . .	7	63	72	66	75	29
Average mark . . . . .	10	18	26	35	36	43
Standard deviation . . . . .	8·91	8·52	9·25	14·02	13·57	15·14
Highest mark . . . . .	27	43	49	66	74	85
Lowest mark . . . . .	0	0	4	16	3	12
Average error . . . . .	6·3	2·96	2·4	2·45	2·6	3·4

## 2.—Subtraction (Series 12).

Age . . . . .	8½	9½	10½	11½	12½	13½
Number . . . . .	7	63	72	66	76	29
Average mark . . . . .	22	35	45	64	74	81
Standard deviation . . . . .	13·27	21·56	20·14	23·97	29·56	29·11
Highest mark . . . . .	50	84	95	128	134	145
Lowest mark . . . . .	7	0	0	0	14	17
Average error . . . . .	8·6	9·2	7·5	7·1	5·5	5·6

## 3.—Multiplication (Series 12).

Age . . . . .	8½	9½	10½	11½	12½	13½
Number . . . . .	7	63	72	67	76	33
Average mark . . . . .	23	32	40	61	69	80
Standard deviation . . . . .	10·84	12·98	17·65	23·24	28·48	27·71
Highest mark . . . . .	48	62	86	121	136	136
Lowest mark . . . . .	12	10	8	18	7	30
Average error . . . . .	3·1	3·57	5·0	3·03	4·1	3·66

## 4.—Division (Series 12).

Age . . . . .	8½	9½	10½	11½	12½	13½
Number . . . . .	7	63	72	67	76	33
Average mark . . . . .	14	19	26	46	57	63
Standard deviation . . . . .	9·56	11·09	13·63	24·41	30·9	26·33
Highest mark . . . . .	35	65	68	102	143	119
Lowest mark . . . . .	2	2	0	8	0	16
Average error . . . . .	7·0	5·52	7·0	3·8	7·2	5·4

TABLE IX.

*W. R. (Mixed) School.*

## 1.—Addition (Series 12).

Age . . . . .		8½	9½	10½	11½	12½	13½
Number . . . . .	B.			33	66	67	35
	G.	30	58	69	74	78	48
Average mark . . . . .	B.			38	46	48	49
	G.	20	26	33	40	44	46
Standard deviation . . . . .	B.			11·92	19·9	17·5	16·3
	G.	7·22	11·0	13·11	20·1	25·2	13·6
Highest mark . . . . .	B.			64	100	154	110
	G.	37	60	81	80	178	85
Lowest mark . . . . .	B.			12	17	16	23
	G.	5	5	8	12	19	26
Average error . . . . .	B.			2·1	2·2	2·0	2·0
	G.	1·17	1·45	2·2	1·3	1·55	1·75

## 2.—Subtraction (Series 12).

Age . . . . .		8½	9½	10½	11½	12½	13½
Number . . . . .	B.			33	67	67	35
	G.	30	58	69	74	78	48
Average mark . . . . .	B.			72	82	90	97
	G.	36	50	65	78	81	98
Standard deviation . . . . .	B.			21·22	42·13	36·83	30·6
	G.	16·6	24·1	27·4	30·04	26·4	38·9
Highest mark . . . . .	B.			119	194	184	152
	G.	68	115	128	165	182	185
Lowest mark . . . . .	B.			19	15	16	35
	G.	7	9	12	11	37	30
Average error . . . . .	B.			6·4	6·9	5·0	4·6
	G.	4·0	5·93	4·93	3·86	4·0	4·85

## 3.—Multiplication (Series 12).

Age . . . . .		8½	9½	10½	11½	12½	13½
Number . . . . .	B.			33	66	68	35
	G.	30	58	69	74	78	48
Average mark . . . . .	B.			58	69	74	81
	G.	25	41	51	61	71	83
Standard deviation . . . . .	B.			17·8	30·95	23·41	22·46
	G.	8·5	18·6	20·1	19·09	22·38	28·3
Highest mark . . . . .	B.			116	164	140	124
	G.	39	83	101	105	159	156
Lowest mark . . . . .	B.			18	24	18	25
	G.	7	13	16	17	36	41
Average error . . . . .	B.			3·7	3·9	4·4	4·9
	G.	2·8	2·6	1·6	3·2	2·9	3·9

## 4.—Division (Series 12).

Age . . . . .		8½	9½	10½	11½	12½	13½
Number . . . . .	B.			33	66	68	35
	G.	30	58	69	74	78	48
Average mark . . . . .	B.			45	60	66	69
	G.	14	27	26	55	62	66
Standard deviation	B.			18·56	38·9	26·67	23·41
	G.	6·9	16·5	20·3	28·2	29·8	29·64
Highest mark . . . . .	B.			82	177	124	133
	G.	29	61	89	150	172	131
Lowest mark . . . . .	B.			20	10	3	14
	G.	2	0	1	6	5	20
Average error . . . . .	B.			4·75	3·75	3·9	5·3
	G.	3·4	3·5	2·5	2·6	2·5	2·87

TABLE X.

*Correlation between the Age Groups of School C (Sheffield) (Boys).*

Age	Addition and Subtraction	Addition and Multiplication	Addition and Division	Subtraction and Multiplication	Subtraction and Division	Multiplication and Division	Average
8	·806	·400	·580	·390	·868	·758	·634
9	·623	·574	·643	·573	·492	·744	·608
10	·706	·622	·664	·669	·783	·727	·695
11	·492	·628	·703	·794	·700	·908	·704
12	·771	·864	·900	·752	·693	·910	·815
13	·87	·776	·726	·728	·770	·784	·776
Average	·711	·644	·703	·651	·718	·805	·705

*Popular Science Lectures.—Interim Report of the Committee, consisting of the PRESIDENT and GENERAL OFFICERS, Professor H. E. ARMSTRONG, Professor W. A. BONE, Sir EDWARD BRABROOK, Professor S. J. CHAPMAN, Professor A. DENDY, Professor R. A. GREGORY (Hon. Sec.), Professor W. D. HALLIBURTON, Dr. H. S. HELE-SHAW, Professor F. KEEBLE, Mr. G. W. LAMPLUGH, and Dr. E. J. RUSSELL, appointed by the Council to consider and report on the Popularisation of Science through Public Lectures. (Drawn up by the Secretary.)*

#### INTRODUCTION.

At the meeting of the Council in June 1916 representations were made by the Organising Committee of Section L (Educational Science) that much less attention is given to popular lecturing now than was formerly the case; and it was suggested that efforts should be made to promote increased public interest in science by means of such lectures. The Council, therefore, appointed a Committee representative of all the Sections of the Association to institute inquiries into this subject and prepare a Report upon it. Many local Scientific Societies, Universities, University Colleges, and similar institutions have organised popular science lectures; and the Committee has endeavoured to secure the results of the experience obtained, with the object of discovering the elements of success or failure.

A schedule of twelve questions was drawn up and was widely distributed. To prevent misunderstanding, it was pointed out in an explanatory letter that the inquiry referred only to single pioneer lectures for the general public, and was not concerned with students' courses, such as are arranged by University Extension authorities, the Workers' Educational Association, and other organisations.

A circular containing the schedule of questions was addressed to (1) Principals and Registrars of all Universities (except Oxford and Cambridge) and University Colleges in the United Kingdom; (2) Principals, or Directors, of all Technical Colleges represented in the Association of Technical Institutions; (3) Secretaries of every University Extension Delegation, or Board, of the Workers' Educational Association, the Gilchrist Trust, and like organisations; (4) Secretaries of all Corresponding Societies and of forty other local Scientific Societies; (5) Curators of the chief provincial Museums; (6) a few individuals having special knowledge of the subject.

By the middle of August, about 150 circulars had been returned, nearly all of them containing replies to the questions and also many valuable comments. The whole of these replies—about 1,500 in all—have been classified, and a digest of their substance is here given. The first question asked for the name of the society or institution providing the information.



## ABSTRACT OF REPLIES TO QUESTIONS.

(2) *Are arrangements made for the delivery of public lectures upon scientific subjects each session? If so, (a) are the lectures free? (b) What are the lowest and highest charges for admission?*

In most cases local scientific societies arrange for the delivery of occasional popular lectures each session. These lectures, however, are not usually intended for the general public, but for members of the societies and any friends who may accompany them. The lectures are thus more of the nature of scientific meetings than public assemblies, and the fee for admission to them is the membership subscription, which varies from 1s. to a guinea per session. In a few cases one or more public lectures are arranged each session, and admission to these is free, or at nominal charges varying from 1d. to 6d.

Series of public lectures are arranged by several Corporations in connection with museums, libraries, and other institutions, as well as by Universities and Technical Colleges. The annual series of Corporation Free Lectures at Liverpool includes scientific subjects; at the Horniman Museum, Forest Hill, S.E., twenty free lectures are given on Saturday afternoons from October to March; at the Manchester Museum, sixteen public lectures are arranged each year; at the National Museum of Wales, Cardiff, lectures are given from time to time in connection with special exhibits in the museum; at the Technical School, Barrow-in-Furness, a course of popular lectures is delivered on Saturday evenings; and at the Museum, Free Library, and Bentlif Art Gallery, Maidstone, free popular lectures were successfully arranged every winter before the War. The Secretary of the Buchan Club, Aberdeen, remarks of public lectures: 'They were formerly given until they declined for want of suitable lecturers and variety of lectures'; and the Principal of Battersea Polytechnic says: 'We have discontinued the arrangement of popular lectures as the attendance was discouraging. We have found that the people in this district will not attend popular lectures, whatever the subject. We have offered lectures by such men as Max O'Rell, E. T. Reed, J. Foster Fraser, T. P. O'Connor, Sir J. D. McClure, F. Villiers, Fred Enoch, and H. Furniss; and the response of the public was disappointing, although the charge for admission was only 3d. We arranged for a lecture on "Air-ships" in the Spring of this year, but failed to secure an audience and had to cancel the lecture.'

(3) *Where are the lectures usually given? (a) What is approximately the average attendance?*

Lectures given in rooms of Museums, Public Libraries, Universities, Technical Schools, and like institutions, attended by members of scientific societies and their friends, have usually audiences of about 30 in number, and the limit of accommodation does not often exceed about 200. The average attendance of the whole of the lectures of which particulars have been received is about 300. In the Town Hall, Stockport, the average is 1,250, 'but this is a decreasing number'; at the Mechanics' Institution, Burnley, it is 800-1,200; at the Town

Hall, Portsmouth, 500-2,000; at the Merchant Venturers' Technical College, Bristol, 600-800; at the Birmingham and Midland Institute, 700; at the Albert Institute, Dundee, 500-800; at various towns distributed through England, Wales, and Ireland the average attendance at Gilchrist Lectures is about 600; and at the Geographical Institute, Newcastle, about 500.

(4) *What subjects attract the largest audiences?*

From the point of view of local scientific societies, the most popular subjects are local archæology and antiquities, animal and bird life, and other aspects of natural history. The most popular public lectures are those on travel and adventure by explorers whose names are widely known. Astronomy is rarely mentioned, but this is probably because local scientific societies are mostly concerned with natural history and there are few good lecturers on astronomy. Science lectures must be illustrated by lantern slides or experiments if they are to appeal to a large public, and their titles should arrest attention. The chief point, however, is that lectures should deal with recent discoveries or topics which have been mentioned frequently in the daily newspapers. The largest audiences are usually attracted not by descriptive lectures on such subjects as mimicry, the descent of man, prehistoric animals, trade processes, and so on, but by those which are concerned with questions of wide economic or sociological interest, such as industrial research in America, wireless telegraphy in war, the wages problem, munitions of war, &c. One correspondent says: 'Purely scientific lectures do not attract, however eminent the lecturer. The most attractive lectures are the least scientific.'

(5) *Do you attach as much importance to the lecturer as to the subject?*

As much, or more, importance is usually attached to the lecturer as to the subject. Most of the replies are in this sense, and the following are typical of them: 'The society does not, but the audience does'; 'In order to attract subscribers, the chief importance is attached to the personality and celebrity of the lecturer'; 'The lecturer practically determines the audience'; 'Undoubtedly, if the lecturer is well known'; 'Yes, more, for popular lectures'; 'More to the lecturer, if known: if not known, to the subject.' The best combination is, of course, an attractive subject and a celebrated lecturer, and the public soon forms its own estimate of the two factors. 'The subject attracts in the first instance, but a poor lecturer would not draw a second time.'

'Under the conditions here [Forest Hill, S.E., Horniman Museum], where there is a large population to draw on, title and subject are probably more important than lecturer. Nevertheless, some lecturers are always fairly sure of a good audience, and a series which begins with lectures by relatively poor lecturers soon suffers a reduction in size of audiences.' In many cases the lectures are given by members of the staffs of local museums, universities, or other institutions, but this limitation of choice of lecturer and subject soon exhausts the public interested in them.

(6) *Are lectures by strangers generally more or less successful than those by local lecturers?*

When the visitor is a celebrated lecturer, it is natural that larger audiences should be secured than in the case of local lecturers. Probably strangers are not invited to lecture unless they have more than a local reputation, and this accounts for the general opinion that they are more successful as regards size of audience. Typical replies to this question are: 'Lectures by strangers, especially when they are celebrities, are far more attractive'; 'Yes, as they are usually well-advertised: otherwise, I doubt if the numbers would be increased'; 'Except for lecturers of world-wide fame, we find the attendance about the same for local lecturers as for outside lecturers'; 'A known name, local or otherwise, is generally more attractive than that of a completely unknown person'; 'Strangers distinguished in literature, science, or public life generally attract good audiences. In the case of scientific lectures, local lecturers appeal more to the general public owing to the fact that it is a difficult matter for an outside lecturer to provide adequate experiments. The majority of these lectures in the past have been delivered by our own staff' (University College, Nottingham). 'It depends on the lecturer; when a local lecturer lectures repeatedly in the same district he ceases to draw really large audiences' (Manchester).

The general conclusion seems to be that for lectures to local societies, with audiences numbering from about 30 to 100, local lecturers 'draw' as much as visiting lecturers of the same standing, but the visitor has to depend more upon the subject and title to attract an audience. 'The fact that a prophet is not without honour save in his own country somewhat discounts the popularity of local lecturers; but a distinguished local man will attract a larger audience than a much less distinguished stranger' (Manchester).

(7) *If fees are paid to lecturers, what is the usual amount for (a) Lectures with or without lantern slides, (b) Lectures with experimental illustrations?*

Few local societies have sufficient funds to pay lecturers: the result is that most scientific lectures arranged by these societies are given free or for out-of-pocket expenses. Members of the staffs of colleges and other institutions also usually give public lectures locally without fees. The general fee to professional lecturers, with lantern slides or experimental illustrations, or both, varies from three to ten guineas. Dr. Wertheimer, Principal of the Merchant Venturers' College, Bristol, says, in answer to this question: 'Varies with the lecturer. We have found some dear at five guineas and others cheap at fifteen guineas.' The Stockport Science Lectures Committee usually pays ten guineas for a lecture, but in exceptional cases, as for Sir Ernest Shackleton and Sir H. B. Tree, forty guineas have been paid.

(8) *With admission free, or at a nominal charge, and excluding the cost of the hire of a room or hall, what is the usual profit or loss upon a popular science lecture? (a) If there is a loss, how is it met?*

(9) *Are any local funds available for people's lectures?*

As lectures to members of local scientific societies and their friends are usually given free, expenses are low and are met by the general funds of the societies. The Secretary of the Buteshire Natural History Society says: 'Some years we have had lectures for the public for which a charge was made—about 6*d*. There was usually a profit, after paying everything, of a few shillings.' There is, however, rarely a profit upon a public lecture. The Buchan Club, Aberdeen, estimates the loss at 1*l*. to 2*l*. per lecture, and it is paid from the funds of the society. Even with the well-arranged Gilchrist Lectures delivered in various parts of the country, the average loss is about 10*l*. a lecture and is met by a grant from the Gilchrist Trustees. At Stockport 'the hall has been hired, with charges for admission. The greatest profit in the early years was approximately 20*l*. In recent years there has been a loss. A number of local gentlemen guaranteed a guinea each in case of loss. No call has been made upon them.'

At University College, Nottingham, the loss per lecture is from 2*l*. to 5*l*., but no allowance is made for the services of the lecturer and his assistant, or for the use of apparatus. In such cases the loss is met out of College funds. Lectures are likewise given in many places as part of the educational work of museums and the cost is paid out of the incomes of the institutions. When the museum is a municipal institution, or lectures are arranged by a Free Public Library Committee, any loss comes out of the rates. Thus, the Secretary of the Albert Institute, Dundee, says: 'As the lectures are all delivered within the premises of the Free Library Committee, any charge for admission is prohibited by the Public Libraries Acts. The Albert Institute Lectures have proved so popular that they are regarded as a branch of the work of the Free Library Committee. A sum of about 25*l*. is usually taken in the estimates of that Committee for expenses—lantern operator, making slides, arranging halls, &c. All my lectures are gratuitous.'

Similarly, the Chief Librarian of the Liverpool Public Libraries remarks: 'The public libraries are rate-supported, and lectures are part of the public library work. This library was established by special Act of Parliament, and not under Ewart's Library Act. Authority was included in our Act to pay for lectures. The vote by our Council for lectures during the past few years has been about 1,100*l*. per year.'

In other cases the cost of popular lectures is paid by the local Education Committee or out of the grant made to the institution by the Board of Education.

Very few localities have special funds available for the expenses of public lectures. The Secretary of the Kilmarnock Glenfield Ramblers' Society says, however: 'The Kilmarnock Philosophical Society has considerable funds for providing lectures, but has not done so for many years.' At Dundee, 'the late Lord Armitstead gave, about twenty-five years ago, a sum to establish "The Armitstead Lectures." No local lecturers are engaged. A nominal charge for admission is made. These were formerly well attended, but latterly the attendance has fallen off. The Albert Institute Lectures now tax the full accommodation of the Albert Hall. They are absolutely free to the public.'

There is at Perth a local Trust Fund, called the Duncan Bequest, for lectures; and at Maidstone the popular lectures are provided out of the Bentlif Wing Trust Fund of the Museum, Free Library, and Bentlif Art Gallery. The Midland Institute, Birmingham, has a small endowment of about 30*l.* a year for science lectures; and the Royal Technical College, Glasgow, has an endowment fund for popular lectures on astronomy. The Gilchrist Educational Trust is referred to in detail later. One of the purposes of the Chadwick Trust (40 Queen Anne Chambers, Westminster, S.W.) is to provide for 'the delivery by competent persons of lectures on Sanitary Science,' and a number of successful lectures have been given in pursuance of it, particularly during the War. Among the subjects of these recent lectures are: Racial Hygiene and the Wastage of War; War and Disease; Food in War-time; Typhus in Serbia; Prevention of Disease and Frostbite in the Army. The Trust pays all expenses of fees, hall, lantern, advertising, and printing, though halls and lanterns are often lent.

(10) *Has public interest in popular science lectures increased or decreased in your district during the past ten or twenty years?*

The analysis of replies to this question is inconclusive. About one-third of the correspondents report that interest has increased, another third that it has decreased, and the remaining third that it has remained stationary or no decided change has been noticed. Museums mostly report an increase of interest, and technical institutions a decrease. No general conclusion can be derived from the replies from scientific societies, in which so much depends upon the energy of the secretary and the constitution of the committee. For example, the Birmingham and Midland Institute Scientific Society reports an increase, while the Birmingham Natural History and Philosophical Society records a decrease.

As regards public interest in science lectures Dr. M. E. Sadler remarks: 'I should say that it has increased and might be greatly stimulated by further efforts.' Other replies to this effect are: 'I do not believe that public interest in popular science lectures has decreased, but it certainly has less opportunities of manifesting itself' (School of Technology, Manchester). 'There has been a marked increase of interest within the past five years' (University College, Aberystwyth); 'In that time the public interest in our lectures has increased considerably' (Kilmarnock); 'The interest in the Manchester Geographical Society's weekly lectures has greatly increased during the past fifteen years.'

The chief causes of decrease of interest in many districts are indicated in the following replies: 'The public interest has doubtless decreased slightly during the past ten years. This is to some extent accounted for by the fact that during recent years scholars from the secondary and other schools in the city have continued their education at the college and other institutions, attending two and three evenings per week, and therefore do not attend single lectures as in former years. The opening of picture-houses has probably also affected the attendance at lectures' (University College, Nottingham). 'Decreased. The

lectures are no longer novel, there is increasing difficulty in obtaining new and good lecturers, and there are many counter-attractions, *e.g.* kinema, other lectures in the same town, &c.' (Stockport Science Lectures Committee). 'Decreased: representatives on public bodies either have not the time (through commercial claims), or the interest, to devote any attention to the matter' (Chelmsford). 'I should say decreased with the quality of the lecture. Good lectures are rare and generally well attended' (Plymouth).

The whole matter is admirably summed up by Mr. D. B. Morris, Town Clerk, Stirling, as follows:—

'Comparing the position of matters now with that of thirty years ago, the popular lecture does not now occupy the place in public esteem which it did. For this there are various causes. With the better type of young persons, attendance at continuation classes, with their organised schemes of study, takes the place of attendance at popular lectures. To the non-studious the picture-house is the habitual place of resort. Many of the films there shown are such as would be exhibited at a popular science lecture.

'As regards older people, some find that life has to be lived more strenuously nowadays, and rest or quiet recreation are sought in the evening rather than anything distinctly intellectual. The great popular interest which used to be taken in natural history arising out of the "evolution" controversy, and inspired also by the writings of Darwin, Wallace, Huxley, Lubbock, Kingsley, and others, has passed entirely away. Such interest now centres in subjects like wireless telegraphy, aviation, and, at present, all matters connected with the war.

'Serious students will always be found to attend courses where educational value is to be got, but popular lectures will not succeed unless illustrated by kinematograph, lantern, or experiments, or by all three. The element of entertainment must be present, which implies novelty. Arrangements might be made with local picture-houses to have a fortnightly or monthly scientific evening, which would take the form of a popular lecture with illustrations. Tickets, containing a short syllabus of the series, could be sold at cheap prices, a local organisation assuming financial responsibility.'

(11) *Can you suggest any course of action to follow in order to increase public interest in science in your district by means of popular lectures?*

The chief needs referred to are: (1) a supply of trained popular lecturers; (2) co-ordination of effort of educational institutions, University Extension Committees, Municipal Corporations, Trades Councils, and similar bodies; (3) adequate advertisement and interesting Press notices; (4) lectures dealing more especially with subjects of present-day interest, or relating to the needs of the district; (5) endowment of popular science lecturers so as to enable lectures to be provided at a moderate cost; (6) the use of the kinematograph in science lectures.

Many correspondents seem to think that popular lectures are necessarily of the instructive kind and intended to induce people to take up courses of study at educational institutions. They have little faith in such a means of increasing the number of students, and rightly so.

The purpose of public lectures may be, however, not so much to create desire to study as to enlighten the community upon the relation of science to individual and national life. The point of view is thus entirely different from that of the local educational institution or the local scientific society, both of which regard popular lectures as possible means of securing new students or members. The position is clearly stated by Principal Garnett, School of Technology, Manchester, in the following reply: 'A more general realisation by competent lecturers of the benefits which popular lectures may confer upon the community and a greater readiness on the part of Universities and Colleges to spend money on the provision and advertisement of such lectures. At the present time eminent men of science are, with few (if any) exceptions, rendering in other ways more valuable national service than they could render by the delivery of popular lectures. Moreover, the restricted financial resources of Governing Bodies are probably more usefully employed in the conduct of research and in providing the education required by men who are to occupy responsible positions in the various industries. The financial difficulty would disappear if an inspiring account of the broad outlines of natural science formed part of the curriculum of every elementary and secondary school. This "science for all" is to be carefully distinguished from the science training given to those who are to pursue further the study of science in some institution of higher education or are to use it in their daily work.'

Mr. R. J. Moss (Royal Dublin Society) says: 'Much more attention must be given to science in school education. It should be made interesting and taught as much as possible by demonstration and experiment. In this way the coming generation may be enabled to appreciate science and to take an interest in the progress of knowledge. A great deal of good might be done by the creation of travelling lectureships to be held for a limited time by men who show an aptitude for the work.'

(12) *What do you consider are the chief elements of success, or reasons for failure, of public lectures upon scientific subjects?*

Among the conditions of success mentioned in replies to this question are: (1) The reputation and personality of the lecturer, (2) effective advertisement and newspaper reports, (3) energy and efficiency of local secretaries and committees, (4) attractive titles, and choice of topical or popular subjects, (5) plenty of lantern slides, use of bioscope films, or good experimental illustrations. It is obvious that a lecturer should adapt himself to his audience, and should possess expository power, so as to deal with his subject in a clear and interesting manner, without degenerating into the style of a public entertainer.

Professor Herdman states the chief element of success to be 'a good lecturer who can be heard, has a definite story to tell, and can tell it in plain language.' This is also the view of Principal Garnett, who says: 'The chief elements of success seem to me to be that the lecturer should be vividly conscious of the closest relation that exists, or that can be established, between his subject and the daily lives of his audience; and that he should possess an expert knowledge of his subject, a power of lucid exposition, and a pleasant and forcible delivery.'

The replies received show that these conditions are rare among lecturers; and failure is often ascribed to the absence of them. A subject and style appropriate to a lecture at the Royal Institution are unsuitable for a working-class audience such as that at the Royal Victoria Hall, though this is sometimes forgotten. The Librarian and Director of the Sunderland Public Libraries, Museum, and Art Gallery, remarks: 'The expertness of the lecturer and his constant association with experts often causes him to be ignorant of the ignorance of his audience. On the other hand, he is occasionally patronising. In failing to approach his subject from their point of view he is occasionally "over their heads," and, despite his specialisation, frequently fails where "a man of the people," or a non-expert, will succeed with less knowledge, but better judgment. There should be the same difference between a "popular lecture" and a scientific discourse, as between an interesting primer and an advanced scientific treatise in literature. The successful "popular" lecturer is, I think, more rare than the advanced or scientific lecturer. Failure may possibly be attributed to the growth of light-entertainment halls, or maybe to a wider and more popular treatment of subjects in the Press. There is also a greater literature now, and a wider circulation of it through libraries.'

Even in lectures to local scientific societies the subjects are frequently treated in too advanced a manner, and are therefore unintelligible to many of the audience. It is suggested by some correspondents that if more attention were given to science in schools there would be a larger attendance at popular lectures; but much depends upon the nature of the science teaching. The Principal of the Technical School, Barrow-in-Furness, writes: 'I am afraid that one of the causes lies in the dreary nature of the instruction in "science" given in the day-schools (secondary). No one here who has learnt chemistry, for instance, in a day-school seems to wish to learn more.'

The thirst for amusement and excitement, no doubt, accounts largely for want of interest in science by the great majority of the public. There are now so many counter-attractions, such as picture palaces, music-halls, and other places of entertainment, that the general public is attracted to them rather than to lectures which require mental effort to understand them. 'People want recreation after the day's work, and prefer amusement rather than instruction.'

Experience shows that in an ordinary provincial town there is usually a small minority of intelligent persons who profit considerably from popular or semi-popular science lectures, but that the general community of the district is untouched by them. 'Such attempts as have been made to reach larger audiences, with a low standard of education, by means of ultra-popular lectures have proved failures' (Gloucester). In this, as in most cases, lectures of the instructive type are referred to, and not those which aim at the appreciation of science as a living force in social economics or State affairs. Mr. H. J. Lowe, Secretary of the Torquay Natural History Society, remarks: 'The only way I can see to helping science into its proper position as an essential in national development is by the recognition and proclamation by the Government and educational authorities of its



immeasurable importance in attaining national efficiency. This should be followed by some general scientific knowledge being required in all passing examinations, as a guarantee of an acquaintance with science method and reasoning.'

The provision now made for the study of scientific and technical subjects accounts, no doubt, for the failure of popular lectures in many districts. When there were few institutions of higher education, the thoughtful section of the population took advantage of such lectures to extend their knowledge, but now the same class is provided for in educational institutions and courses. The public science lectures of the present times, therefore, need not be of the same kind, or on the same subjects, as those of a past generation, but should be adapted to more modern needs and interests. Above all, they should be intended for the people as a whole, and not for students or others who propose to devote systematic attention to the subjects of the lectures or devote their careers to them. This distinction is not recognised in the sub-joined remarks by Mr. C. F. Procter (Hon. Sec., Hull Scientific and Field Naturalists' Club), which represent the views of many scientific societies as to the present position, yet it is most important.

Mr. Procter says: 'Scientific lectures can only be made popular in the sense that you attract the crowd of unscientific people, with a profusion of experiments, or, failing that, lantern illustrations. People will flock to the Egyptian Hall and are vastly entertained and educated a little by an exhibition of what is often clever scientific acrobatics. Human nature loves to see what it cannot understand, and twenty years ago represents a period when the commonplaces of science were a wonderland to the average mind. The trend of education has altered that, and has sharply divided the same people into a minority of scientific enthusiasts who "ask for more," and a majority of indifferents who remain cold at a display of the old elementary stuff. Education (and that includes very largely the popular science lectures of the past) has created in this, as in all the arts, a small aristocracy of intellect, or, rather, comparatively small. These are not satisfied with anything that can possibly be popular. They are long past that, but will feverishly attend anything which proposes further to explore the deep water. The crowd—the man in the street and his women-kind—has had its wonder-bump excised in the school laboratory. Modern sensationalism in amusement and the plethora of scrappy yet crisp literature (which religiously exploits every new thing, scientific or otherwise, that may entertain) has calloused this excision. The application of the film-pictures to microscopy, &c., is about the only way to popularise science lectures, but—why bother? We cannot all be men of science, and the present system provides that any who get the call may answer it, whilst popular lectures only attempt to entertain individuals of an age who are already past the slightest hope of ever being useful scientists. The proper thing is already being done by our schools, universities, and University Extension lecturers with our budding professors.'

The following letter from the Acting Registrar of University College, Nottingham, bears upon some of the foregoing points: 'Popular

lectures have been delivered for the past thirty-five years at this college. During the past few years the numbers delivered on science subjects have been less than in previous years, but there is good reason to believe that if some pecuniary assistance from a central fund could be devoted to lectures on science much progress might be made, not only in this city but throughout the whole of the East Midland area. At one time it was the practice to arrange during each session two or three series of lectures on scientific subjects during the winter terms. These series consisted of three or four weekly lectures on each subject and were generally delivered by professors of the college. The professors received no extra remuneration for this work and as the ordinary college work grew it was almost impossible for the time to be spent in the preparation, which, it can be well understood, was very extensive. Ten to fifteen years back we always had crowded audiences, but these were cut down owing to the opening of so many picture-houses in the city and also to the fact that many of the senior scholars from the secondary and other schools now continue their education at the college and other institutions, attending two and three evenings per week.'

#### CONSTRUCTIVE PROPOSALS.

Many correspondents are of the opinion that the formation of a panel of lecturers who would be prepared to assist small societies by lecturing for a small fee would be of great assistance. Mr. H. V. Thompson, Hon. Sec. of the North Staffordshire Field Club, says: 'It would greatly facilitate matters if the British Association prepared a list of lecturers on various scientific subjects who, although not necessarily in the first rank of scientific attainment, could be relied upon to give lectures which would hold and interest a normal popular audience. This course would much assist local clubs and societies in the difficult choice of lecturers and also enable them to gauge the interest in science in the district. Furthermore, promising young men would be introduced to districts where they are unknown at the present time.'

Mr. H. E. Forrest, Hon. Sec. of the Caradoc and Severn Valley Field Club, makes much the same suggestions, as follows: 'I think local societies might help each other a great deal more than they do. In almost every society there are one or two members who are good lecturers on some particular branch of natural science. These might, in many instances, be willing to lecture to other societies for their expenses or a nominal fee. I suggest that you prepare a list of these gentlemen (giving addresses), with the subjects on which they lecture, and send the list to all corresponding societies, leaving it to their secretaries to make arrangements direct with the respective lecturers.'

Mr. Herbert Bolton, Curator of the Bristol Museum and Art Gallery, suggests that there should be an exchange system of lecturers among museum curators: 'If, say, a dozen curators had all to work up lectures upon subjects with which they are familiar, they could, by arrangement, deliver the lecture at eleven other places in addition to their own, and so put in a good winter's work and make a good lecture reach a wide audience.' Similar suggestions are made by several correspondents for the exchange of lecturers among local scientific societies.

## GENERAL OBSERVATIONS.

In addition to the replies to the individual questions, some valuable general remarks have been received, and a selection from them is here given. Dr. Alex. Hill, Principal, University College, Southampton, writes: 'Twenty years' experience as a Gilchrist lecturer has taught me that the success of a popular lecture depends wholly upon organisation. Not once in a score of Gilchrist lectures is there a seat vacant in the largest hall in the town, wherever it may be. A committee is formed long before the Gilchrist lectures are to be given: on it the representatives of all working-class organisations, Y.M.C.A., churches and chapels in the place. Very commonly every ticket for the course is sold before the lectures commence. It is needless to say that the Gilchrist lectures have a high reputation; but the public has little, if any, knowledge of the qualifications of an individual lecturer. The only chance of drawing an artisan population to a lecture is to let them have a share of the responsibility of arranging for it, and therefore of securing a large audience. There has been no diminution in interest in popular scientific lectures in my time—say, forty years—but there has been a great falling off in the trouble taken in organising audiences.'

Dr. W. B. Burnie, Principal of the Brighton Technical College, says: 'The reasons of success or failure depend on what you want your popular lectures to accomplish. The objects can be:—

- (a) To give a little scientific knowledge to the general public.
- (b) To remove prejudices against scientific work and attempt to make the public more sympathetic.
- (c) To interest individuals in scientific work so that they take up seriously some branch of science.

'(a) seems to me to have been achieved so far as popular lectures, without effort on the part of the public, can accomplish it.

'(b) seems not able to be accomplished by popular lectures. The numerous people who distrust and dislike science do not attend popular lectures.

'(c) is a reasonable object for the lectures; but where it is the object the lectures are more likely to be successful where they are arranged to display the resources of a particular institution, as in the case of the lectures we have here.

'The most important constructive proposal for the popularising of science is the proposal to put it on the same footing as literary knowledge for examinations for the Civil Service and the like. So long as the scientific man is subordinated to the literary man in our public work—so long as the entrance examinations to the Universities and the Army and other professions may be mainly literary and cannot be mainly scientific—so long will the general public regard science as either a hateful innovation or a rather interesting by-product which does not pay. In face of this you cannot popularise science.'

Frequent reference is made by correspondents to the success of Gilchrist lectures. These lectures are arranged under the auspices of the Gilchrist Educational Trust, which has the administration of a fund amounting originally to 70,000*l.* The trustees have founded scholar-

ships, made considerable grants of money from time to time to educational institutions, and expended, in the forty-one years from 1868 to 1909, nearly 40,000*l.* on lectures on scientific and other subjects to working-men in the various towns of Great Britain and Ireland. Lord Shuttleworth, Chairman of the trustees, described the work of the trust in an address to the Bolton Education Society in 1910, and the address is published in pamphlet form. The Secretary of the trust is Dr. A. H. Fison, who has prepared for the present Committee the subjoined valuable statement of its work and his own views based upon long and successful experience as a public lecturer.

In framing the report Dr. Fison has had the advantage of advice and suggestions from Lord Shuttleworth, who, as Sir Ughtred Kay-Shuttleworth, became one of the trustees in 1877, and has ever since taken the keenest interest in all the work of the trust.

#### REPORT ON THE GILCHRIST POPULAR LECTURES.

By Dr. A. H. Fison, Secretary to the Gilchrist Trustees.

The Gilchrist Lectures were first given in 1866, and were then organised by Dr. W. B. Carpenter, at that time secretary to the trustees. Dr. Carpenter died in 1885, and was succeeded after a short interval by Dr. R. D. Roberts, who acted as secretary until his death in 1911, after which date it became my duty to continue the work. Like Dr. Roberts, I have taken a keen interest in the lectures, that constitute only a part of the activities of the trustees, and my experience has given me some definite ideas of the possibilities of popular lectures on science, as well as some upon the caution that it is necessary to exercise in their organisation if they are to achieve their highest educational purpose.

The number of Gilchrist Lectures arranged annually has varied from time to time, but, for a considerable period, about one hundred lectures have been arranged for each winter, and this number may, I think, be taken as a fair average. These hundred lectures have been given at twenty selected towns, a course of five being allotted to each, and delivered at fortnightly intervals. In early years at least one endeavour was made to give continuity to a course, though the lectures were given by different lecturers, but the lectures have more generally been upon different subjects, which again have been so selected as to open up as many different views of science as possible. The trustees have from the beginning exercised great care in their invitation to the gentlemen they have asked to lecture for them, in regarding, as essential qualifications, high academic distinction as well as the possession of the personal qualification that enables some men to treat a subject with worthy dignity and at the same time to hold the attention of a popular audience. Among the names of the many distinguished men who have assisted the trustees as lecturers those of Prof. Dallinger, Sir Robert Ball, and Prof. Vivian Lewes at once occur as those of lecturers who have been pre-eminently successful, as well as those to whom the success of the Gilchrist Lectures has been largely due. For the first thirty-two years the lectures dealt exclusively with scientific subjects, but in 1898 Sir Charles Waldstein lectured for the trustees upon Greek Art. The

experiment was so successful that further lectures upon Art and upon History have been introduced since, and, although about four-fifths of the lectures are still devoted to Science, there appears no reason to regard lectures dealing with Art and History as being less attractive to the working-classes, at any rate so long as they are introduced in a series in which the greater number of lectures are devoted to Science, than those dealing with Natural Science.

The trustees are accustomed to ask their lecturers to accept an honorarium of ten guineas, with first-class travelling-expenses, for each lecture, and the towns at which lectures are arranged are if possible so combined that a lecturer may conveniently visit several in succession. Most of the lecturers have generally devoted two weeks, one before and the other after Christmas, in the winter to this work, giving five lectures in each week.

As regards organisation, the trustees are accustomed to receive early in every year a number of applications for grants of lectures for the following winter. The applications come from local education authorities, from committees of public libraries, from local philosophical and scientific societies, and from other bodies. In the event of a favourable reply, and with the view of arousing the widest interest in the lectures, the committee applying is asked to form a Local Lectures Committee on which all educational interests as well as all labour organisations in the locality are represented. Whenever possible, it was the custom of my predecessor, Dr. Roberts, to visit the local committee, and sometimes to address preliminary public meetings on the subject of the forthcoming lectures. I have been very careful to follow this precedent, and have during the past four years addressed a number of public meetings arranged for dates a few weeks preceding the lectures upon different subjects of educational interest, and I am convinced of the usefulness of these meetings as a step towards ensuring the success of the course. When suggesting their arrangement to the local committee, I always request them to endeavour to obtain the support of the Mayor or some other person of influence as chairman, and I have generally been happy in obtaining this support.

The usual financial arrangement with the local committee is for them to defray all strictly local expenses. A regular lanternist, who accompanies the lecturers on their rounds, is appointed by the trustees, and receives 2*l.*, plus his travelling-expenses, for each lecture. The lanternist's fee was originally paid by the local committee, but the trustees have recently consented to defray one-half of it. To raise funds necessary to meet local expenses, the committee is empowered to devote one-tenth of the seating capacity of the hall to reserved seats, the price of these being left to its discretion. The rest of the hall is open to artisans at the nominal charge of sixpence for the five lectures, perforated tickets of admission being attached to a small book containing syllabuses of the lectures and portraits of the lecturers. Certain modifications are allowed in cases where the local committee makes a contribution to the cost of the lectures.

The average attendance at the Gilchrist Lectures from 1911 to 1913, the three years immediately preceding the war, was slightly over 600.

In former times the average exceeded this considerably, but the difference is accounted for in part, though possibly not entirely, by the fact that the trustees have in later years made grants of lectures to smaller towns. A very great deal depends upon the energy and enthusiasm displayed by the members of the local committee, and, above all, by the secretary—it is impossible to exaggerate the importance of this point. Much as the masses of the British people appreciate a good lecture when they attend it, it needs hard work and a perfect organisation to secure good attendance at the lecture-hall, however attractive the subject and however eminent the lecturer.

From my own twenty-five years' experience as a lecturer, and from the similar experiences of many other lecturers with whom I have discussed the question, I am inclined to think that the interest of the working-classes of the country in popular lectures has somewhat decreased during the past quarter of a century. The marked decrease in the demand for Gilchrist Lectures that has taken place might appear to be definite evidence of this, but it is difficult to judge how far this is due to the increased stringency of the conditions that have been imposed by the trustees from time to time. Except in special circumstances, grants of lectures are now made only to those towns where the trustees are assured that a *bona-fide* attempt will be made to follow them by a course of more sustained study; no grant is made where a course of lectures has been given during the eight years preceding unless a contribution is received towards the cost, and grants are not made to county boroughs and large towns in possession of funds for educational purposes without a very substantial contribution, usually from 30*l.* to 40*l.*, being made towards their cost.

The following causes may, in my opinion, have contributed to a decreased interest in the lectures:—

1. The keen interest now taken by working-men in their trades unions and in labour problems in general. In a few cases, the outbreak of labour troubles has seriously interfered with the success of courses actually in progress.

2. The facilities for entertainment supplied by music-halls, kinema exhibitions, and football, as well as in other ways.

3. The increased educational facilities now provided locally in a great many towns, either by universities or technical institutes. Towards the foundation of many of the latter the trustees believe the Gilchrist Lectures to have contributed, partly because of the interest in natural science they have aroused, but also partly in consequence of pressure exerted and conditions imposed by the trustees in by-gone years before promising courses of lectures in a big town.

Although there appears to be some evidence of a general diminution of interest in popular lectures, there are still many cases where no such decrease is apparent. Some of these, illustrated by the great success that has recently attended courses of Gilchrist Lectures at Blackpool, Norwich, and Yarmouth, it seems difficult to classify, but the general experience supplied by the Gilchrist Lectures seems to be that in industrial towns that lie off the well-beaten track of civilisation, such as, for instance, those of the colliery districts in South Wales and Cumber-

land, interest is as keen as ever, while it is well maintained in the smaller manufacturing towns. In these towns too, especially in many of those of the former class, the interest developed by the lectures appears to be particularly intense in raising the thoughts of the audiences above their immediate surroundings, and in opening up visions of new aspects of nature hitherto unsuspected. In many cases, the lecturer will be invited to accompany members of his audience to their homes, and the discussion of the lecture will be continued as far into the night as human nature allows, while the same lecture, delivered at a large town on the more beaten track, may more likely be received with merely polite attention and there will generally be less impressive evidence of interest in the subject of the lecture being maintained beyond its conclusion.

The experience of the Gilchrist Lectures has been mainly derived from England and Wales. Some courses have been arranged in Ireland and in Scotland. A few applications are still received from Ireland, but there has been no demand for lectures in Scotland in recent years. No steps have been taken to publish the readiness of the trustees to consider applications for grants, the reputation of the lectures themselves having hitherto proved sufficient each year before the war to cause far more towns to ask for lectures than it has been possible to include in the succeeding winter's programme.

A note of warning should, I think, be added with regard to the possibility of popular lectures doing occasional harm by developing a taste for them that may be inimical to more serious work. My attention was directed to this point some years ago by the secretaries of the Oxford and Cambridge University Extension Boards, both of whom instanced cases where, as they alleged, Gilchrist Lectures had had an injurious effect upon their own classes. I was at first very reluctant to accept this conclusion, but later experience has convinced me that it may not have been without foundation. In a few cases within my own experience, where I have urged the importance of establishing classes, either in connection with the University Extension movement or classes of a similar character, in sequence with courses of Gilchrist Lectures, I have been met with remarks to the effect that 'The Gilchrist Lectures have been so successful that our audiences very much prefer courses of unconnected lectures on similar lines,' and I have not always been successful in overcoming these difficulties. A large number of courses of disconnected lectures, varied by performances of popular entertainers, are given every winter throughout the country. They are, no doubt, useful as recreative entertainments and as counteractions to undesirable attractions, but their educational influence would appear to be small, and they may do occasional harm in discouraging educational endeavour that might lead to higher achievement. These considerations have been recognised by the trustees, who now insist in most instances on imposing conditions as to work of higher educational value being organised as the outcome of a course of lectures.

The main conclusions to which the experience supplied by the Gilchrist Lectures would appear to point are consequently:—

1. Although the demand for popular lectures among the working-

classes may not be quite as great as it formerly was, they are still capable of achieving as great success as ever in towns that lie off the more beaten track, and appreciable success in the smaller manufacturing towns.

2. In every case the success of a course of lectures requires thorough local organisation and the hearty co-operation of all classes.

3. The best popular lecture deals rather with the important part of education that concerns the spiritual side of man than the side that deals with the immediate acquisition of knowledge. The effect is in the main stimulating and suggestive, and a course only fulfils its full purpose when such a result follows and is utilised in supplying an inspiration for further endeavour of higher educational value.

4. Popular lectures that degenerate into mere forms of entertainment, while they doubtless fulfil a useful purpose in supplying counter-attraction to entertainments of less desirable character, may be harmful to the cause of real education by discouraging more worthy endeavours.

---

Dr. Fison's report embodies the results of experience gained by others and himself in organising popular lectures under the direction of the Gilchrist Trustees during a period of fifty years. A similar historical account of the free lectures movement in Liverpool, prepared for the Liverpool Library, Museum, and Arts Committee by Mr. G. T. Shaw, Chief Librarian, on the fiftieth anniversary (1865-1914-15), has been published by the Corporation and is here abridged. These two accounts show clearly the position of popular lectures in large towns both in the past and at the present time.

#### LIVERPOOL CORPORATION FREE LECTURES.

Lectures to which the public are admitted free are regarded to-day as necessary auxiliaries of public library work, and many committees of public libraries in the United Kingdom have organised such lectures, while many more would do so if funds and accommodation could be provided. The Public Libraries Acts under which so many libraries are established do not authorise payments for lectures. Liverpool was fortunate in securing a private Act of Parliament for the establishment of its public library and museum, and the promoters of that Act were wise enough and enterprising enough to include in it a clause giving authority to organise those free lectures, the jubilee of which in this city we have now attained.

No action was taken under this power until the year 1865. That the matter was not overlooked, however, is proved by the fact that care was taken to provide for a lecture-hall capable of seating 350 people in the plans of the building for the library and museum which Sir W. Brown generously presented to Liverpool. This must have been one of the first gifts of a building for a public library and museum in England, and it was certainly the first public library and museum in this country, built after the passing of the Public Libraries Act, to possess a lecture-



hall. To-day the Liverpool Public Library, Museum, and Arts Committee possess two lecture-halls, the one above referred to, and the Picton Lecture Hall (opened 1882), capable of seating 1,200 people, and both are used in connection with the lecture-work of the institutions.

In the year 1861 there was founded the Liverpool School of Science, to 'promote a knowledge of Science and Art and the application thereof to the various industries.' The school was successfully conducted in the lecture and class rooms in the new Public Library and Museum building, but as time passed a want was felt of popular lectures to supplement the instruction given in the school. These the Committee of the School of Science could arrange, but could not afford to pay for; consequently, in the year 1865, the Committee of the Public Library and Museum were approached to undertake the work. The Library Committee considered that the suggestion came within the scope of their commission, and arranged for four courses of ten lectures on each of the following subjects: Geology, Chemistry, Geometry, and Natural Philosophy. Admission to the lectures was, of course, free, and the attendances numbered 2,666. The total cost was 100*l*.

This was regarded as a success from the Library Committee's point of view, and 'confirmed the Committee of the School of Science in the opinion which they entertained: that, whilst there is a fair demand for scientific instruction in Liverpool, the class which seeks such instruction is unable to pay much for it.' But it also had to be reported that 'the attendance at the lectures of the School of Science had further diminished in consequence of the opening of the free lectures.' The Committee of the School of Science considered that the continuance of a double course of lectures alike in aim and character might prove injurious to both, and recommended that 'only one suitable programme of scientific lectures should be issued for the future and that that should emanate from the Library and Museum Committee.' This recommendation was adopted, and since the year 1865 Liverpool has never been without its annual series of Corporation free lectures.

The Liverpool Corporation free lectures as organised to-day have been subjected to the criticism that through being single lectures on many subjects they are less effective from an educational standpoint than they would be if divided into courses of lectures on fewer subjects. In view of this criticism it will be interesting, and may be useful, to trace the developments of our lectures from 1865 to 1896, when the present system was adopted.

As already stated, the first series of lectures in 1865 consisted of 40 lectures divided into 4 courses of 10 lectures each, and were on strictly scientific subjects. During the succeeding 9 years, courses of lectures in Literature and Art as well as Science were continued, the number of lectures in the courses varying from 12 to 2. In 1875 40 lectures were given, of which 5 were single lectures and the remainder short courses varying in number but not exceeding 6 lectures in one course.

In 1878 there were 41 lectures divided into 1 course of 3 lectures, 10 courses of 2 each, and 18 single lectures. In 1865 there were 40 lectures and 4 lecturers; in 1875 40 lectures and 14 lecturers, while

in 1878 there were 41 lectures and 29 lecturers. Though the popularity of the single lecture was established, the Committee were evidently reluctant to discontinue courses of lectures, as in 1878 they divided the programme into two sessions, allocating courses of lectures to the autumn and single lectures to the winter months.

Neither labour nor money was spared to make the autumn courses of lectures popular, useful, and successful. As this policy was continued from 1878 until 1892 it must have met with encouraging success. But with the growth of the University and the development of other educational agencies in the city, the needs of those people who wanted the more detailed study of literary and scientific subjects that courses of lectures afford were supplied. Statistics show that the attendances at the lectures were not maintained. Courses which had four or five hundred people at the first lecture ended with an attendance of sixty or seventy. On the other hand, the winter series of single lectures maintained their popularity. Consequently in 1893 the Committee discontinued the courses of lectures and made the autumn series consist of single lectures. In 1896 the Lectures Sub-Committee abolished the division of autumn and winter series and substituted the present series extending from November to March.

In the year 1906 special lectures for children were introduced. At first six lectures were provided, but that number was increased to sixteen the following year, and in 1913 twenty-one were given. The Sub-Committee exercise a care in the selection of both lectures and lecturers which fully justifies the popularity of these lectures—a popularity which taxes the seating capacity of all the halls they are delivered in.

The policy of the Lectures Sub-Committee may be defined as an endeavour to present in popular form the results of the latest developments and discoveries in literature, art, and science—including travel, sport, and geographical exploration. As far as possible the lectures have always been illustrated by diagrams, specimens, and objects from the museum, exhibitions of books, and scientific experiments. The oxyhydrogen light was first used in connection with these lectures in 1876: electric light has long since been substituted for lime-light, and now the bioscope film is superseding the lantern-slide.

But while endeavouring to make the lectures entertaining, instructive, and popular, the Sub-Committee never lose sight of the fact that they are an important part of the library work. A list of books obtainable at the Reference and Branch Libraries on the subject of each lecture is printed under the title of the lecture in the programmes, and when possible the list is written on a lantern-slide and projected on to the screen just before the commencement of the lecture.

In the year 1865 there was a total attendance of 2,666 people at the 40 lectures then delivered—an average of 66 per lecture. Last Session (1913-14) 72,613 people attended 169 lectures—an average of 430 per lecture. In 1865 the amount expended on lectures was 100*l.*, and in 1913 it was 1,100*l.* Since the inauguration of these lectures 3,801 have been delivered to a total number of 2,324,090 people.

---

## LECTURE TYPES.

Three types of popular lectures may be distinguished, namely: (1) Lectures to members of local scientific societies and others interested in scientific subjects; (2) people's lectures, with lantern-slides and experiments. These are of a recreative kind and somewhat of the nature of entertainments; (3) lectures showing the relation of science to various aspects of national life, such as industry, education, practical politics, and so on. These have for their object the creation of a large body of opinion in support of the claims of science to an influential position in the State.

(1) The programmes of local scientific societies show that a wide range of subjects is covered, and that a valuable service is rendered by the opportunities which the meetings and lectures afford of obtaining sound ideas upon scientific matters and developments. A few subjects may be mentioned from many hundreds referred to in the reports submitted: Aerial Navigation; Heredity; The Daylight Saving Bill; Medieval Alchemy; The Story of Moving Pictures; Roger Bacon; Colliery Explosions; Wheat; The Food We Eat; How to Distinguish Wild Birds; Lord Lister and his Work; Gyroscopes and Gyroscopic Devices; Wireless Telegraphy; The Web of Life; Afforestation; From Grub to Butterfly; The Splendours of the Heavens; Insect Mimicry; A Piece of Limestone; Insects as Carriers of Human and Animal Diseases; Radium; Coal and Fuel Economy; Chemical Science and Industry; Drops and Bubbles; Humble-bees; The Air We Breathe; Creatures of Other Days; Spectrum Analysis; Migration of Birds; The Distribution of Wealth; Bacterised Peat; Tuberculosis; Civilisation and Food; The Alternation of Generations; Colour Photography; Ancient Herbals; Volcanoes: their Origin and Nature; Astronomical Sidelights on Archæological Problems; The Study of Splashes; Romance of Insect Life; The Calendar; Light and Vision; Mendelism; Poisonous Plants; Aphides (Green Flies); Bees and their Diseases; Bacteria in Daily Life; Protective Colouration; Shooting Stars; The Senses—News-agents of the Mind; Munitions of War; The Life of a Star; The Colours of a Soap Bubble.

It is obvious from an examination of reports and syllabuses that, in most districts, local societies and institutions provide already for the needs of the circle of people interested in scientific work and development. The societies seem, however, to make up their programmes independently, and depend very largely upon local lecturers. It would be an advantage if each society and institution would send to a central committee a list of about half-a-dozen lecturers and their subjects who would be prepared to lecture at other centres. The list could then be printed and distributed to all the bodies contributing to it, and each body would thus have before it not only many possible subjects of lectures, but also be able to secure outside lecturers for them if so desired.

(2) Outside the circle of local societies and educational institutions is the large mass of the community completely apathetic to scientific development and with no desire for knowledge. This part of the

population can be reached only by entertainment or by an appeal to what may be termed their political interests. The members of it do not wish to be instructed in their leisure hours, but seek for amusement and wonderment, though they are often keenly interested in subjects of national or economic importance. The best avenue to their attention to scientific discovery and teaching is the picture-house, and it should be frankly recognised that the films shown must not demand much mental effort to comprehend them. By a selection of suitable films of geographical, industrial, and scientific subjects, it would be possible to enlighten the mass of the people as to the varying aspects of Nature and life in many parts of the world, the resources of the Empire, the wonders of natural history, and the services of science to national life and industrial progress.

Increasing use is being made of bioscope films to illustrate popular lectures, and in the future these moving pictures will, in many cases, supersede the lantern-slides which attracted the public in former years. When there is a large demand for such pictures, producers of them will be glad to meet it, but at present they mostly devote attention to sloppy sentiment, stupid antics, and Wild West sensationalism. Messrs. Pathé Frères formerly possessed a number of very fine films illustrating the circulation of the blood and the phenomenon of phagocytosis, sleeping sickness, the development of the axolotl, and similar subjects treated in a way to interest and instruct popular audiences, but they now say, in reply to an inquiry, 'A short time ago all these original productions were taken out of stock, owing to the very bad condition they were in.' Letters have been sent to a number of firms believed to possess films of scientific, geographical, and industrial subjects which may be hired for lecture purposes, and the following lists should be of service in making suitable selections. It would usually be possible to arrange with a local picture-house for the hire of the hall and the exhibit of the films selected:—

*Kineto, Ltd., 80-82 Wardour Street, London, W.*

*Animals, Birds, Fish, Reptiles, &c.*

Among the Reptiles (400 ft.); Walk through an Aquarium (500 ft.); Butterfly Farming (415 ft.); Pussy's Cousins (480 ft.); Fun in a Bear Pit (465 ft.); British Birds of Prey (455 ft.); Curiosities of Insect Life (480 ft.); Humours of Animal Life (430 ft.); Birds of Moorland, Marsh, and Mountain (320 ft.); Microscopic Pond Dwellers (440 ft.); Snapshots at the Zoo (405 ft.); An Otter Study (510 ft.); Studies of Aquatic Life (450 ft.); Nature's Little Tragedies (440 ft.); Trout Farming in Surrey (540 ft.); Studies in Furs and Feathers (470 ft.); Unique Studies of Nature, No. 1 (330 ft.); Unique Studies of Nature, No. 2 (380 ft.); Unique Studies of Nature, No. 3 (380 ft.); Four-footed Friends (385 ft.); Friends in Feathers (380 ft.); Unattractive Pets (420 ft.); Pigeon Studies (310 ft.); Cormorant Study (340 ft.); Peculiar Pals (435 ft.); In Field and Hedgerow (425 ft.); Life of a Wasp (505 ft.); Life on a Rocky Shore (490 ft.); From Egg to Fry (360 ft.); Bird Studies, No. 1 (305 ft.); Wild Silk Moth (380 ft.); Bird Studies, No. 2 (315 ft.); Unfamiliar Animals (305 ft.); The Jackdaw (380 ft.); The Life of a

Plaice (420 ft.); Confessions of Pongo (445 ft.); Animal Drolleries (460 ft.); Birdland Studies (355 ft.); Nature's Aviators (360 ft.).

#### *Industrial.*

An Eastern Industry (330 ft.); Making a Modern Railway Carriage (560 ft.); How a Railway Line is made (345 ft.); Making a Motor Cycle (740 ft.); Modern Methods of Repairing Tram Lines (265 ft.); On a Coffee Plantation (476 ft.); Construction of a 4-Cylinder Engine (745 ft.); Salmon Fisheries at Sooke (475 ft.); Timber Industry of British Columbia (510 ft.); Life on a Ranch (410 ft.); Experiment in Chemistry of Combustion (535 ft.); Irish Cloth Industry (365 ft.).

#### *Scientific.*

Wonders of Crystallization (400 ft.); From Egg to Chick (455 ft.); Sugar Industry in Jamaica (405 ft.); Electrolysis of Metals (410 ft.); Chemical Crystals (340 ft.); Birth of a Flower (500 ft.); Germination of Plants (430 ft.); Horticultural Pests (420 ft.).

#### *Miscellaneous Films.*

A Day in the Life of a Coal Miner (595 ft.); Native Oyster Fishing (375 ft.); Ancient Delhi (420 ft.); Roaming through India (375 ft.); Scenes in New Zealand (530 ft.); Glimpses of Ceylon (475 ft.); Benares (310 ft.); Crossing the Line (370 ft.); Llandudno (375 ft.); Temples and Religious Ceremonies of Java (395 ft.); Winter Climbing at Snowdon (510 ft.); Trip through North Wales (450 ft.); Through Rob Roy's Country (420 ft.); What the Eye does not See (480 ft.); Some Wonderful Waterfalls (295 ft.); The Care of Horses (480 ft.); Travels in Belgium (585 ft.); From Antwerp to Ostend (475 ft.); Scenes in Hungary (450 ft.); The Emerald Isle (445 ft.); Sand Siftings (325 ft.); Rambles in Sweden (455 ft.); A Trip through Norway (375 ft.); Kill that Fly! (455 ft.); Milford Sound, N.Z. (425 ft.); Wonders of Static Electricity (330 ft.); Floral Favourites (405 ft.); Trip up the Clyde (460 ft.); Venice and the Grand Canal (395 ft.); The Shantung Silk Moth (360 ft.); The Scottish Lowlands (400 ft.); North Wales, the British Tyrol (415 ft.); Genoa and its Surroundings (475 ft.); Picturesque Japan (475 ft.); Rome (485 ft.).

*Butcher's Film Service, Ltd., Camera House, Farringdon Avenue, London, E.C.*

#### *Travel, Sporting, Industrial, and Educational Pictures. Taken in the British Colonies.*

*New Zealand.*—The Maori at Home (375 ft.); Running Waters of New Zealand (271 ft.); A Day in the New Zealand Bush (340 ft.); Scenes in a Kauri Forest, N.Z. (458 ft.); New Zealand's Wonder Land (253 ft.); Familiar Sightings in Geyserland (420 ft.); City of Wellington, N.Z. (345 ft.); New Zealand River Scenery (283 ft.); Trout-fishing on Lake Taupo, N.Z. (350 ft.); The N.Z. Flax Industry (455 ft.); Modern Cheesemaking in Taranaki, N.Z. (420 ft.).

*South Africa.*—Life in a Kaffir Kraal (250 ft.); Rail and River Trip up the beautiful Umkommas, Natal (220 ft.); Scenes in and around Cape Town (435 ft.); Views of Durban (260 ft.); A Railway Ride to Delagoa Bay (345 ft.); Sunday Morning Scenes in a Kaffir Compound (510 ft.); Pretoria, Capital of United South Africa (360 ft.); Bloemfontein and Kimberley (330 ft.); Johannesburg—The Golden City (315 ft.); Holiday on the Zambezi (495 ft.); Visit to Khama's Country, Bechuanaland (455 ft.); Scenes in the Province of Mozambique (335 ft.); Diamond-seeking on the Vaal River (265 ft.); How the Natives of South Africa are Educated (342 ft.); From Ostrich Egg to Feather Boa (430 ft.); The Rhodesian Tobacco Industry (360 ft.); The Whaling Industry of Natal (500 ft.); Gold-mining in Rhodesia (255 ft.); Native Industries on the Rhodesian Railway (445 ft.); The Wattle Bark Industry of Natal (340 ft.); The Mechanical Coaling of Ships at Durban (275 ft.); An Old Dutch Grape Farm, Groot Constantia, Cape Colony (275 ft.); The Home of the Famous Cullinan Diamond (How diamonds are found on the Premier Diamond Mine, Pretoria) (500 ft.).

*Canada.*—Picturesque Niagara (420 ft.); Lachine Rapids, Montreal, Canada (320 ft.); Canoe Trip on the French River (280 ft.); A Canadian Summer Resort (Lake of Bays) (370 ft.); A Trip to the Muskoka Lakes (400 ft.); A Trip through the Thousand Islands (460 ft.); Scenes on the Grand Trunk Pacific (335 ft.); A Fishing Trip in Northern Ontario (340 ft.); Deer-hunting in the Highlands of Ontario (425 ft.); Harvesting Scenes in Western Canada (300 ft.); Silver-mining in Cobalt, Canada (375 ft.); Timber Industry on the Fraser River (460 ft.); Peach-growing in the Niagara Peninsula, Canada (380 ft.); Fruit and Vegetable Farming in the Garden of Canada, St. Catherine's (255 ft.); The Building of a Trans-continental Railway in Canada (630 ft.); Apple Industry in Canada (225 ft.); Peterborough Hydraulic Lift Lock, Ontario (400 ft.).

*Australia.*—Among the Ferns and Waterfalls of the Blue Mountains (250 ft.); A Visit to the Jenolean Caves, N.S.W. (250 ft.); The Cockle Industry near Sydney (420 ft.); Constructing the Dam at Barrinjack, N.S.W. (395 ft.); Wool Industry in New South Wales (466 ft.).

*Various.*—The City of York: The Eboracum of the Romans (403 ft.); Salt Industry at Hyères (France) (260 ft.); The Manufacture of Golf Clubs (350 ft.); Royal Porcelain Works, Worcester (485 ft.).

*Charles Urban Trading Company, Ltd., Urbania House, Wardour Street, Shaftesbury Avenue, London, W.*

Chemical Action; Chemical Experiments; Microscopical Animosities; Curious Caterpillars; Life in a River Backwater; Fish Life; The Winshurst Machine; Pond Life (micro-kinematograph); The Life of a Bee; Little Drops of Water (micro-kinematograph).

*Pathé Frères Cinema, Ltd., 84 Wardour Street, London, W.*

Sunny Spain; In Ancient Seville; The Environs of Mount Dore; Village Life in Central India; Here and There in Spain; On the Catalonian Side of the Pyrenees; Winter in the Pyrenees.

Mr. J. Fairgrieve, who has given particular attention to the use of the kinematograph in geographical teaching, says in reply to an inquiry: 'The only really extensive detailed catalogue of geographical films for sale is that published by the Charles Urban Trading Co., Ltd. There are a few short films of 50 or 60 feet taking approximately a minute to run through, such as Old Street, Colombo, or Camel Caravans crossing the Nile Bridge, Cairo, and there are a few long composite films of 800 feet, such as Cairo to Khartum, but the usual length is from 300 to 400 feet. Such scenic pictures are Yellowstone National Park (350 ft.); From Salonica to Smyrna (365 ft.); Railway Trip in the Tyrol (400 ft.); Railway over the Andes (400 ft.). Some films dealing with processes are Slate Mining in North Wales (360 ft.); Trapping Salmon (75 ft.); Distilling (900 ft.); Logging in Norway (180 ft.).

'Messrs. Pathé Frères have an enormous stock of valuable geographical films, many on a non-flam base, both for sale or hire, but the absence of a published catalogue makes it extremely difficult to find out what films are really suitable for geographical work. Among many others the following should be of considerable use: Pau from a Dirigible (412 ft.); The Rubber Industry in Malaysia (360 ft.); Cultivation of Coffee at Santos (480 ft.).

'Jury's Imperial Pictures, 7A Upper St. Martin's Lane, and M. P. Sales Agency, 86 Wardour Street, also supply films.

'The High Commissioners for the Commonwealth of Australia, 72 Victoria Street, S.W., and for New Zealand, 13 Victoria Street, have films illustrating the life industries and scenery of these lands, which are lent free of charge to lecturers or societies of repute.'

(3) There is especial need at the present time of lectures showing the relation of science to many aspects of national life. Science and scientific method mean progress and efficiency, and the more this is recognised the greater will be the interest taken in the promotion of scientific study and investigation. The majority of the people in these islands regard science as a thing apart from their everyday lives; and even when they admire devotion to it or appreciate the advantages given them by scientific research, they think it is outside the world of practical affairs, whether commercial, industrial, or administrative. It is time that a systematic effort was made to remove this common impression and to bring science into close touch with social and political movements. By this means alone can a large body of opinion be created in support of the claims of science to an influential position in the State. The people as a whole will remain untouched by descriptive science lectures, however good the lecturer or important the subject, but they are ready to respond to a call for national efficiency associated with science in the place of the opportunisms of political parties of the past. What is particularly wanted to gain this end is lectures by advocates of science and scientific method, whether they are themselves professional men of science or not. The lecturers need not be original investigators or distinguished professors, provided that they are good speakers and have sufficient knowledge of the history of science and industry to show to an audience the debt which civilisation owes to

its scientific workers whether in the laboratory, the field, or the workshop. The time has come for the organisation of this propaganda work, and every encouragement should be given to societies or men who will take part in it. Political parties send lecturers all over the country to expound their principles: there should now be lecturers who will similarly spread the message of science and efficiency and secure support for the men who will promote these factors in all departments of State.

As titles of lectures having this intention, the following may be suggested: England's Neglect of Science and Some of the Results; Unscientific Ministers and their Muddles; Politics and Trade; The Problem of Food; The Claims of Scientific Method; Lost Industries and How to Regain Them; Neglected Resources of the Empire; Politics and Education; State Control by Amateurs; Administration without Science; The Representation of Science and Efficiency in Parliament; Industrial Organisation and its Benefits; The Education of our Masters; Science in National Affairs; What a Ministry of Commerce might do for the Empire; The State as a Co-operative Society; Practical Education; National Waste and its Consequences; The Alliance of Science and Industry; Needs of Modern Life; How to Increase Work and Wages; A New Policy of Progress; The Promotion of Industrial Enterprise; National Economy in Fuel; Capital and Labour; Workshop Hustle and Fatigue; Healthy Homes; Nationalisation of the Highways; Railways as State Services.

#### SUMMARY.

(1) Many local societies arrange for the delivery of occasional popular or semi-popular science lectures, but the audiences are mostly made up of members and their friends.

(2) In most places there is a small circle of people interested in scientific work and development, and sufficient means exist to enable them to extend their acquaintance with diverse branches of natural knowledge, but the great bulk of the community is outside this circle and is untouched by its influence.

(3) Popular lectures on scientific subjects do not usually attract such large audiences as formerly in most parts of the Kingdom. To make a wide appeal to the general public the same principles of organisation, advertisement, and selection of lecturer and subject must be followed as are adopted by agents of other public performances.

(4) Increase in the number of educational institutions has provided for the needs of most persons who wish to study science, either to gain knowledge or prepare for a career. Other people seek entertainment rather than mental effort in their leisure hours, and they require subjects of topical interest, or of social and political importance, to attract them to lectures.

(5) Few popular lectures pay their expenses, and scarcely a single local society has a special fund upon which it can draw in order to meet the cost involved in the provision of a first-rate lecturer and adequate advertisement.



(6) Expenses of public lectures are usually paid from (a) general funds of local societies; (b) college or museum funds; (c) rates; (d) education grants; or (e) Gilchrist and other trusts.

(7) After the war there will be a new public for lectures and courses on a wide range of subjects; but one of the main purposes of the lectures should be to show as many people as possible that they are personally concerned as citizens with the position of science in the State, in industry, and in education.

Certain recommendations arising out of this Report are now under consideration by the Committee.

---

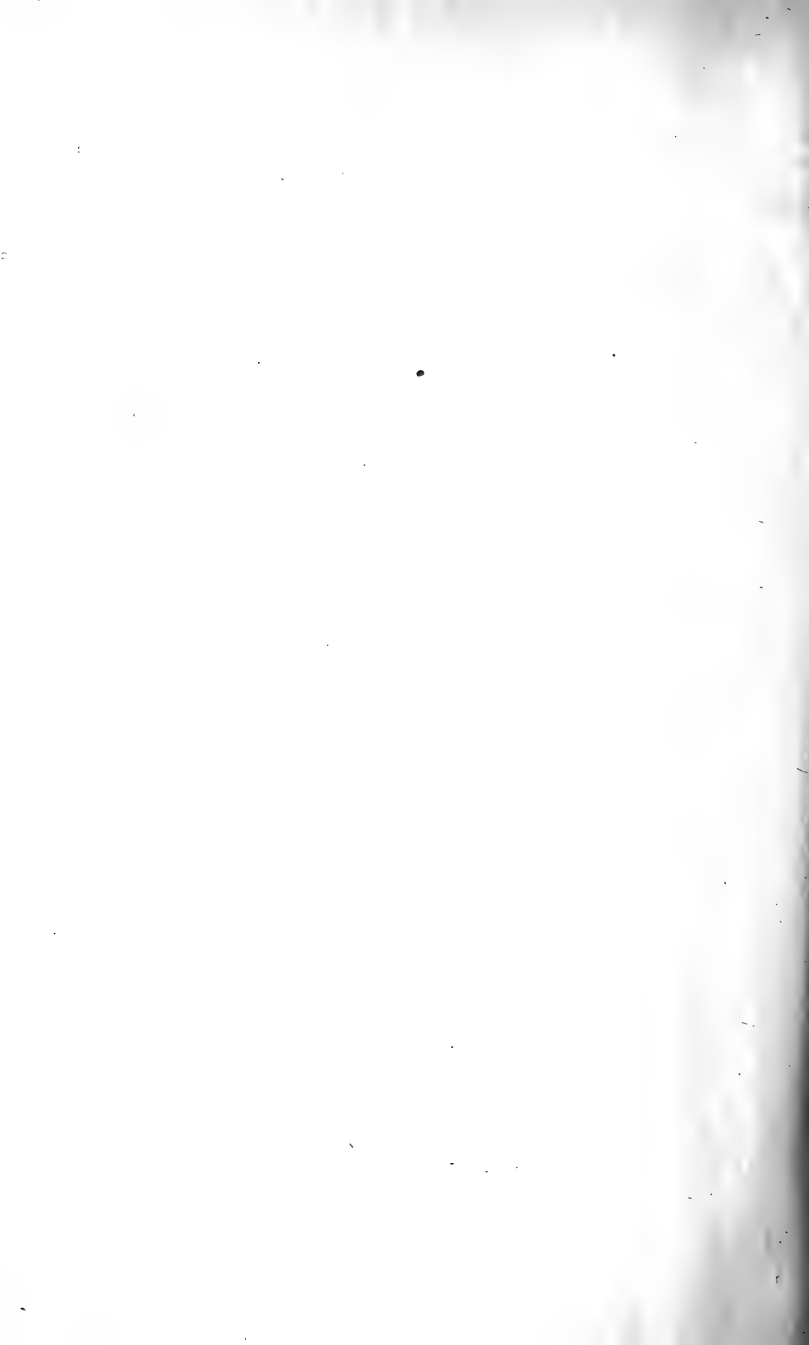



TRANSACTIONS OF THE SECTIONS.



# TRANSACTIONS OF THE SECTIONS.

---

## SECTION A.—MATHEMATICAL AND PHYSICAL SCIENCE.

PRESIDENT OF THE SECTION: PROFESSOR A. N. WHITEHEAD,  
D.Sc., F.R.S.

---

WEDNESDAY, SEPTEMBER 6.

The President delivered the following Address:—

### *The Organisation of Thought.*

THE subject of this address is the organisation of thought, a topic evidently capable of many diverse modes of treatment. I intend more particularly to give some account of that department of logical science with which some of my own studies have been connected. But I am anxious, if I can succeed in so doing, to handle this account so as to exhibit the relation with certain considerations which underlie general scientific activities.

It is no accident that an age of science has developed into an age of organisation. Organised thought is the basis of organised action. Organisation is the adjustment of diverse elements so that their mutual relations may exhibit some predetermined quality. An epic poem is a triumph of organisation, that is to say, it is a triumph in the unlikely event of it being a good epic poem. It is the successful organisation of multitudinous sounds of words, associations of words, pictorial memories of diverse events and feelings ordinarily occurring in life, combined with a special narrative of great events: the whole so disposed as to excite emotions which, as defined by Milton, are simple, sensuous, and passionate. The number of successful epic poems is commensurate, or, rather, is inversely commensurate with the obvious difficulty of the task of organisation.

Science is the organisation of thought. But the example of the epic poem warns us that science is not any organisation of thought. It is an organisation of a certain definite type which we will endeavour to determine.

Science is a river with two sources, the practical source and the theoretical source. The practical source is the desire to direct our actions to achieve predetermined ends. For example, the British nation, fighting for justice, turns to science, which teaches it the importance of compounds of nitrogen. The theoretical source is the desire to understand. Now I am going to emphasise the importance of theory in science. But to avoid misconception I most emphatically state that I do not consider one source as in any sense nobler than the other, or intrinsically more interesting. I cannot see why it is nobler to strive to understand than to busy oneself with the right ordering of one's actions. Both have their bad sides; there are evil ends directing actions, and there are ignoble curiosities of the understanding.

The importance, even in practice, of the theoretical side of science arises from the fact that action must be immediate, and takes place under circumstances which are excessively complicated. If we wait for the necessities of action before we commence to arrange our ideas, in peace we shall have lost our trade, and in war we shall have lost the battle.

Success in practice depends on theorists who, led by other motives of exploration, have been there before, and by some good chance have hit upon

the relevant ideas. By a theorist I do not mean a man who is up in the clouds, but a man whose motive for thought is the desire to formulate correctly the rules according to which events occur. A successful theorist should be excessively interested in immediate events, otherwise he is not at all likely to formulate correctly anything about them. Of course, both sources of science exist in all men.

Now, what is this thought organisation which we call science? The first aspect of modern science which struck thoughtful observers was its inductive character. The nature of induction, its importance, and the rules of inductive logic have been considered by a long series of thinkers, especially English thinkers, Bacon, Herschel, J. S. Mill, Venn, Jevons, and others. I am not going to plunge into an analysis of the process of induction. Induction is the machinery and not the product, and it is the product which I want to consider. When we understand the product we shall be in a stronger position to improve the machinery.

First, there is one point which it is necessary to emphasise. There is a tendency in analysing scientific processes to assume a given assemblage of concepts applying to nature, and to imagine that the discovery of laws of nature consists in selecting by means of inductive logic some one out of a definite set of possible alternative relations which may hold between the things in nature answering to these obvious concepts. In a sense this assumption is fairly correct, especially in regard to the earlier stages of science. Mankind found itself in possession of certain concepts respecting nature—for example, the concept of fairly permanent material bodies—and proceeded to determine laws which related the corresponding percepts in nature. But the formulation of laws changed the concepts, sometimes gently by an added precision, sometimes violently. At first this process was not much noticed, or at least was felt to be a process curbed within narrow bounds, not touching fundamental ideas. At the stage where we now are, the formulation of the concepts can be seen to be as important as the formulation of the empirical laws connecting the events in the universe as thus conceived by us. For example, the concepts of life, of heredity, of a material body, of a molecule, of an atom, of an electron, of energy, of space, of time, of quantity, and of number. I am not dogmatising about the best way of getting such ideas straight. Certainly it will only be done by those who have devoted themselves to a special study of the facts in question. Success is never absolute, and progress in the right direction is the result of a slow, gradual process of continual comparison of ideas with facts. The criterion of success is that we should be able to formulate empirical laws, that is, statements of relations, connecting the various parts of the universe as thus conceived, laws with the property that we can interpret the actual events of our lives as being our fragmentary knowledge of this conceived interrelated whole.

But, for the purposes of science, what is the actual world? Has science to wait for the termination of the metaphysical debate till it can determine its own subject-matter? I suggest that science has a much more homely starting-ground. Its task is the discovery of the relations which exist within that flux of perceptions, sensations, and emotions which forms our experience of life. The panorama yielded by sight, sound, taste, smell, touch, and by more inchoate sensible feelings, is the sole field of its activity. It is in this way that science is the thought organisation of experience. The most obvious aspect of this field of actual experience is its disorderly character. It is for each person a *continuum*, fragmentary, and with elements not clearly differentiated. The comparison of the sensible experiences of diverse people brings its own difficulties. I insist on the radically untidy, ill-adjusted character of the fields of actual experience from which science starts. To grasp this fundamental truth is the first step in wisdom, when constructing a philosophy of science. This fact is concealed by the influence of language, moulded by science, which foists on us exact concepts as though they represented the immediate deliverances of experience. The result is that we imagine that we have immediate experience of a world of perfectly defined objects implicated in perfectly defined events which, as known to us by the direct deliverance of our senses, happen at exact instants of time, in a space formed by exact points, without parts and without

magnitude : the neat, trim, tidy, exact world which is the goal of scientific thought.

My contention is that this world is a world of ideas, and that its internal relations are relations between abstract concepts, and that the elucidation of the precise connection between this world and the feelings of actual experience is the fundamental question of scientific philosophy. The question which I am inviting you to consider is this : How does exact thought apply to the fragmentary, vague *continua* of experience? I am not saying that it does not apply, quite the contrary. But I want to know how it applies. The solution I am asking for is not a phrase however brilliant, but a solid branch of science, constructed with slow patience, showing in detail how the correspondence is effected.

The first great steps in the organisation of thought were due exclusively to the practical source of scientific activity, without any admixture of theoretical impulse. Their slow accomplishment was the cause and also the effect of the gradual evolution of moderately rational beings. I mean the formation of the concepts of definite material objects, of the determinate lapse of time, of simultaneity, of recurrence, of definite relative position, and of analogous fundamental ideas, according to which the flux of our experiences is mentally arranged for handy reference : in fact, the whole apparatus of common-sense thought. Consider in your mind some definite chair. The concept of that chair is simply the concept of all the interrelated experiences connected with that chair—namely, of the experiences of the folk who made it, of the folk who sold it, of the folk who have seen it or used it, of the man who is now experiencing a comfortable sense of support, combined with our expectations of an analogous future, terminated finally by a different set of experiences when the chair collapses and becomes fire-wood. The formation of that type of concept was a tremendous job, and zoologists and geologists tell us that it took many tens of millions of years. I can well believe it.

I now emphasise two points. In the first place, science is rooted in what I have just called the whole apparatus of common-sense thought. That is the *datum* from which it starts, and to which it must recur. We may speculate, if it amuses us, of other beings in other planets who have arranged analogous experiences according to an entirely different conceptual code—namely, who have directed their chief attention to different relations between their various experiences. But the task is too complex, too gigantic, to be revised in its main outlines. You may polish up common sense, you may contradict it in detail, you may surprise it. But ultimately your whole task is to satisfy it.

In the second place, neither common sense nor science can proceed with their task of thought organisation without departing in some respect from the strict consideration of what is actual in experience. Think again of the chair. Among the experiences upon which its concept is based, I included our expectations of its future history. I should have gone further and included our imagination of all the possible experiences which in ordinary language we should call perceptions of the chair which might have occurred. This is a difficult question, and I do not see my way through it. But at present in the construction of a theory of space and of time, there seem insuperable difficulties if we refuse to admit ideal experiences.

This imaginative perception of experiences, which, if they occurred, would be coherent with our actual experiences, seems fundamental in our lives. It is neither wholly arbitrary, nor yet fully determined. It is a vague background which is only made in part definite by isolated activities of thought. Consider, for example, our thoughts of the unseen flora of Brazil.

Ideal experiences are closely connected with our imaginative reproduction of the actual experiences of other people, and also with our almost inevitable conception of ourselves as receiving our impressions from an external complex reality beyond ourselves. It may be that an adequate analysis of every source and every type of experience yields demonstrative proof of such a reality and of its nature. Indeed, it is hardly to be doubted that this is the case. The precise elucidation of this question is the problem of metaphysics. One of the points which I am urging in this address is that the basis of science does not depend on the assumption of any of the conclusions of metaphysics; but that

both science and metaphysics start from the same given groundwork of immediate experience, and in the main proceed in opposite directions on their diverse tasks.

For example, metaphysics inquires how our perceptions of the chair relate us to some true reality. Science gathers up these perceptions into a determinate class, adds to them ideal perceptions of analogous sort, which under assignable circumstances would be obtained, and this single concept of that set of perceptions is all that science needs; unless indeed you prefer that thought find its origin in some legend of those great twin brethren, the Cock and Bull.

My immediate problem is to inquire into the nature of the texture of science. Science is essentially logical. The nexus between its concepts is a logical nexus, and the grounds for its detailed assertions are logical grounds. King James said, 'No bishops, no king.' With greater confidence we can say, 'No logic, no science.' The reason for the instinctive dislike which most men of science feel towards the recognition of this truth is, I think, the barren failure of logical theory during the past three or four centuries. We may trace this failure back to the worship of authority which in some respects increased in the learned world at the time of the Renaissance. Mankind then changed its authority, and this fact temporarily acted as an emancipation. But the main fact, and we can find complaints<sup>1</sup> of it at the very commencement of the modern movement, was the establishment of a reverential attitude towards any statement made by a classical author. Scholars became commentators on truths too fragile to bear translation. A science which hesitates to forget its founders is lost. To this hesitation I ascribe the barrenness of logic. Another reason for distrust of logical theory and of mathematics is the belief that deductive reasoning can give you nothing new. Your conclusions are contained in your premises, which by hypothesis are known to you.

In the first place this last condemnation of logic neglects the fragmentary, disconnected character of human knowledge. To know one premise on Monday, and another premise on Tuesday, is useless to you on Wednesday. Science is a permanent record of premises, deductions, and conclusions, verified all along the line by its correspondence with facts. Secondly, it is untrue that when we know the premises we also know the conclusions. In arithmetic, for example, mankind are not calculating boys. Any theory which proves that they are conversant with the consequences of their assumptions must be wrong. We can imagine beings who possess such insight. But we are not such creatures. Both these answers are, I think, true and relevant. But they are not satisfactory. They are too much in the nature of bludgements, too external. We want something more explanatory of the very real difficulty which the question suggests. In fact, the true answer is embedded in the discussion of our main problem of the relation of logic to natural science.

It will be necessary to sketch in broad outline some relevant features of modern logic. In doing so I shall try to avoid the profound general discussions and the minute technical classifications which occupy the main part of traditional logic. It is characteristic of a science in its earlier stages—and logic has become fossilised in such a stage—to be both ambitiously profound in its aims and trivial in its handling of details. We can discern four departments of logical theory. By an analogy which is not so very remote I will call these departments or sections the arithmetic section, the algebraic section, the section of general-function theory, the analytic section. I do not mean that arithmetic arises in the first section, algebra in the second section, and so on; but the names are suggestive of certain qualities of thought in each section which are reminiscent of analogous qualities in arithmetic, in algebra, in the general theory of a mathematical function, and in the analysis of the properties of particular functions.

The first section—namely, the arithmetic stage—deals with the relations of definite propositions to each other, just as arithmetic deals with definite numbers. Consider any definite proposition; call it '*p*.' We conceive that there is always another proposition which is the direct contradictory to '*p*'; call it '*not-p*.' When we have got two propositions, *p* and *q*, we can form derivative

<sup>1</sup> *e.g.*, in 1551 by Italian schoolmen.



propositions from them, and from their contradictories. We can say, 'At least one of  $p$  or  $q$  is true, and perhaps both.' Let us call this proposition ' $p$  or  $q$ .' I may mention as an aside that one of the greatest living philosophers has stated that this use of the word 'or'—namely, ' $p$  or  $q$ ' in the sense that either or both may be true—makes him despair of exact expression. We must brave his wrath, which is unintelligible to me.

We have thus got hold of four new propositions, namely, ' $p$  or  $q$ ,' and ' $\text{not-}p$  or  $q$ ,' and ' $p$  or  $\text{not-}q$ ,' and ' $\text{not-}p$  or  $\text{not-}q$ .' Call these the set of disjunctive derivatives. There are, so far, in all eight propositions,  $p$ ,  $\text{not-}p$ ,  $q$ ,  $\text{not-}q$ , and the four disjunctive derivatives. Any pair of these eight propositions can be taken, and substituted for  $p$  and  $q$  in the foregoing treatment. Thus each pair yields eight propositions, some of which may have been obtained before. By proceeding in this way we arrive at an unending set of propositions of growing complexity, ultimately derived from the two original propositions  $p$  or  $q$ . Of course, only a few are important. Similarly we can start from three propositions,  $p$ ,  $q$ ,  $r$ , or from four propositions,  $p$ ,  $q$ ,  $r$ ,  $s$ , and so on. Any one of the propositions of these aggregates may be true or false. It has no other alternative. Whichever it is, true or false, call it the 'truth-value' of the proposition.

The first section of logical inquiry is to settle what we know of the truth-values of these propositions, when we know the truth-values of some of them. The inquiry, so far as it is worth while carrying it, is not very abstruse, and the best way of expressing its results is a detail which I will not now consider. This inquiry forms the arithmetic stage.

The next section of logic is the algebraic stage. Now, the difference between arithmetic and algebra is that in arithmetic definite numbers are considered, and in algebra symbols—namely, letters—are introduced which stand for any numbers. The idea of a number is also enlarged. These letters, standing for any numbers, are called sometimes variables and sometimes parameters. Their essential characteristic is that they are undetermined, unless, indeed, the algebraic conditions which they satisfy implicitly determine them. Then they are sometimes called unknowns. An algebraic formula with letters is a blank form. It becomes a determinate arithmetic statement when definite numbers are substituted for the letters. The importance of algebra is a tribute to the study of form. Consider now the following proposition,

The specific heat of mercury is 0.033.

This is a definite proposition which, with certain limitations, is true. But the truth-value of the proposition does not immediately concern us. Instead of mercury put a mere letter which is the name of some undetermined thing: we get,

The specific heat of  $x$  is 0.033.

This is not a proposition; it has been called by Russell a propositional function. It is the logical analogy of an algebraic expression. Let us write  $f(x)$  for any propositional function.

We could also generalise still further, and say,

The specific heat of  $x$  is  $y$ .

We thus get another propositional function,  $F(x, y)$  of two arguments  $x$  and  $y$ , and so on for any number of arguments.

Now, consider  $f(x)$ . There is the range of values of  $x$ , for which  $f(x)$  is a proposition, true or false. For values of  $x$  outside this range,  $f(x)$  is not a proposition at all, and is neither true nor false. It may have vague suggestions for us, but it has no unit meaning of definite assertion. For example,

The specific heat of water is 0.033

is a proposition which is false; and

The specific heat of virtue is 0.033

is, I should imagine, not a proposition at all; so that it is neither true nor false, though its component parts raise various associations in our minds. This

range of values, for which  $f(x)$  has sense, is called the 'type' of the argument  $x$ .

But there is also a range of values of  $x$  for which  $f(x)$  is a true proposition. This is the class of those values of the argument which *satisfy*  $f(x)$ . This class may have no members, or, in the other extreme, the class may be the whole type of the arguments.

We thus conceive two general propositions respecting the indefinite number of propositions which share in the same logical form, that is, which are values of the same propositional function. One of these propositions is,

$f(x)$  yields a true proposition for each value of  $x$  of the proper type;

the other proposition is,

There is a value of  $x$  for which  $f(x)$  is true.

Given two, or more, propositional functions  $f(x)$  and  $\phi(x)$  with the same argument  $x$ , we form derivative propositional functions, namely,

$f(x)$  or  $\phi(x)$ ,  $f(x)$  or not- $\phi(x)$ ,

and so on with the contradictories, obtaining, as in the arithmetical stage, an unending aggregate of propositional functions. Also each propositional function yields two general propositions. The theory of the interconnection between the truth-values of the general propositions arising from any such aggregate of propositional functions forms a simple and elegant chapter of mathematical logic.

In this algebraic section of logic the theory of types crops up, as we have already noted. It cannot be neglected without the introduction of error. Its theory has to be settled at least by some safe hypothesis, even if it does not go to the philosophic basis of the question. This part of the subject is obscure and difficult, and has not been finally elucidated, though Russell's brilliant work has opened out the subject.

The final impulse to modern logic comes from the independent discovery of the importance of the logical variable by Frege and Peano. Frege went further than Peano, but by an unfortunate symbolism rendered his work so obscure that no one fully recognised his meaning who had not found it out for himself. But the movement has a large history reaching back to Leibniz and even to Aristotle. Among English contributors are De Morgan, Boole, and Sir Alfred Kempe; their work is of the first rank.

The third logical section is the stage of general-function theory. In logical language, we perform in this stage the transition from *intension* to *extension*, and investigate the theory of denotation. Take the propositional function  $f(x)$ . There is the class, or range of values for  $x$ , whose members satisfy  $f(x)$ . But the same range may be the class whose members satisfy another propositional function  $\phi(x)$ . It is necessary to investigate how to indicate the class by a way which is indifferent as between the various propositional functions which are satisfied by any member of it, and of it only. What has to be done is to analyse the nature of propositions about a class—namely, those propositions whose truth-values depend on the class itself and not on the particular meaning by which the class is indicated.

Furthermore, there are propositions about alleged individuals indicated by descriptive phrases: for example, propositions about 'the present King of England,' who does exist, and 'the present Emperor of Brazil,' who does not exist. More complicated, but analogous, questions involving propositional functions of two variables involve the notion of 'correlation,' just as functions of one argument involve classes. Similarly functions of three arguments yield three-cornered correlations, and so on. This logical section is one which Russell has made peculiarly his own by work which must always remain fundamental. I have called this the section of functional theory, because its ideas are essential to the construction of logical denoting functions which include as a special case ordinary mathematical functions such as sine, logarithm, &c. In each of these three stages it will be necessary gradually to introduce an appropriate symbolism, if we are to pass on to the fourth stage.

The fourth logical section, the analytic stage, is concerned with the investigation of the properties of special logical constructions, that is, of classes and

correlations of special sorts. The whole of mathematics is included here. So the section is a large one. In fact, it is mathematics, neither more nor less. But it includes an analysis of mathematical ideas not hitherto included in the scope of that science, nor, indeed, contemplated at all. The essence of this stage is construction. It is by means of suitable constructions that the great framework of applied mathematics, comprising the theories of number, quantity, time, and space, is elaborated.

It is impossible even in brief outline to explain how mathematics is developed from the concepts of class and correlation, including many-cornered correlations, which are established in the third section. I can only allude to the headings of the process which is fully developed in the work, 'Mathematica Principia,' by Mr. Russell and myself. There are in this process of development seven special sorts of correlations which are of peculiar interest. The first sort comprises one-to-many, many-to-one, and one-to-one correlations. The second sort comprises serial relations, that is, correlations by which the members of some field are arranged in a serial order, so that, in the sense defined by the relation, any member of the field is either before or after any other member. The third class comprises inductive relations, that is, correlations on which the theory of mathematical induction depends. The fourth class comprises selective relations, which are required for the general theory of arithmetic operations, and elsewhere. It is in connection with such relations that the famous multiplicative axiom arises for consideration. The fifth class comprises vector relations, from which the theory of quantity arises. The sixth class comprises ratio relations, which interconnect number and quantity. The seventh class comprises three-cornered and four-cornered relations which occur in Geometry.

A bare enumeration of technical names, such as the above, is not very illuminating, though it may help to a comprehension of the demarcations of the subject. Please remember that the names are technical names, meant, no doubt, to be suggestive, but used in strictly defined senses. We have suffered much from critics who consider it sufficient to criticise our procedure on the slender basis of a knowledge of the dictionary meanings of such terms. For example, a one-to-one correlation depends on the notion of a class with only one member, and this notion is defined without appeal to the concept of the number one. The notion of diversity is all that is wanted. Thus the class  $a$  has only one member, if (1) the class of values of  $x$  which satisfies the propositional function,

$$x \text{ is not a member of } a,$$

is not the whole type of relevant values of  $x$ , and (2) the propositional function,

$$x \text{ and } y \text{ are members of } a, \text{ and } x \text{ is diverse from } y,$$

is false, whatever be the values of  $x$  and  $y$  in the relevant type.

Analogous procedures are obviously possible for higher finite cardinal members. Thus, step by step, the whole cycle of current mathematical ideas is capable of logical definition. The process is detailed and laborious, and, like all science, knows nothing of a royal road of airy phrases. The essence of the process is, first to construct the notion in terms of the forms of propositions, that is, in terms of the relevant propositional functions, and secondly to prove the fundamental truths which hold about the notion by reference to the results obtained in the algebraic section of logic.

It will be seen that in this process the whole apparatus of special undefinable mathematical concepts, and special *a priori* mathematical premises, respecting number, quantity, and space, has vanished. Mathematics is merely an apparatus for analysing the deductions which can be drawn from any particular premises, supplied by common sense, or by more refined scientific observation, so far as these deductions depend on the forms of the propositions. Propositions of certain forms are continually occurring in thought. Our existing mathematics is the analysis of deductions, which concern those forms and in some way are important, either from practical utility or theoretical interest. Here I am speaking of the science as it in fact exists. A theoretical definition of mathematics must include in its scope any deductions depending on the mere forms

of propositions. But, of course, no one would wish to develop that part of mathematics which in no sense is of importance.

This hasty summary of logical ideas suggests some reflections. The question arises, How many forms of propositions are there? The answer is, an unending number. The reason for the supposed sterility of logical science can thus be discerned. Aristotle founded the science by conceiving the idea of the form of a proposition, and by conceiving deduction as taking place in virtue of the forms. But he confined propositions to four forms, now named A, I, E, O. So long as logicians were obsessed by this unfortunate restriction, real progress was impossible. Again, in their theory of form, both Aristotle and subsequent logicians came very near to the theory of the logical variable. But to come very near to a true theory, and to grasp its precise application, are two very different things, as the history of science teaches us. Everything of importance has been said before by somebody who did not discover it.

Again, one reason why logical deductions are not obvious is that logical form is not a subject which ordinarily enters into thought. Common-sense deduction probably moves by blind instinct from concrete proposition to concrete proposition, guided by some habitual association of ideas. Thus common sense fails in the presence of a wealth of material.

A more important question is the relation of induction, based on observation, to deductive logic. There is a tradition of opposition between adherents of induction and of deduction. In my view, it would be just as sensible for the two ends of a worm to quarrel. Both observation and deduction are necessary for any knowledge worth having. We cannot get at an inductive law without having recourse to a propositional function. For example, take the statement of observed fact,

This body is mercury, and its specific heat is 0.033.

The propositional function is formed,

Either  $x$  is not mercury, or its specific heat is 0.033.

The inductive law is the assumption of the truth of the general proposition, that the above propositional function is true for every value of  $x$  in the relevant type.

But it is objected that this process and its consequences are so simple that an elaborate science is out of place. In the same way, a British sailor knows the salt sea when he sails over it. What, then, is the use of an elaborate chemical analysis of sea-water? There is the general answer, that you cannot know too much of methods which you always employ; and there is the special answer, that logical forms and logical implications are not so very simple, and that the whole of mathematics is evidence to this effect.

One great use of the study of logical method is not in the region of elaborate deduction, but to guide us in the study of the formation of the main concepts of science. Consider Geometry, for example. What are the points which compose space? Euclid tells us that they are without parts and without magnitude. But how is the notion of a point derived from the sense-perceptions from which science starts? Certainly points are not direct deliverances of the senses. Here and there we may see or unpleasantly feel something suggestive of a point. But this is a rare phenomenon, and certainly does not warrant the conception of space as composed of points. Our knowledge of space properties is not based on any observations of relations between points. It arises from experience of relations between bodies. Now a fundamental space relation between bodies is that one body may be part of another. We are tempted to define the 'whole and part' relation by saying that the points occupied by the part are some of the points occupied by the whole. But 'whole and part' being more fundamental than the notion of 'point,' this definition is really circular and vicious.

We accordingly ask whether any other definition of 'spatial whole and part' can be given. I think that it can be done in this way, though, if I be mistaken, it is unessential to my general argument. We have come to the conclusion that an extended body is nothing else than the class of perceptions of it by all its percipients, actual or ideal. Of course, it is not any class of perceptions, but a certain definite sort of class which I have not defined here, except by

the vicious method of saying that they are perceptions of a body. Now, the perceptions of a part of a body are among the perceptions which compose the whole body. Thus two bodies  $a$  and  $b$  are both classes of perceptions; and  $b$  is part of  $a$  when the class which is  $b$  is contained in the class which is  $a$ . It immediately follows from the logical form of this definition that if  $b$  is part of  $a$ , and  $c$  is part of  $b$ , then  $c$  is part of  $a$ . Thus the relation 'whole to part' is transitive. Again, it will be convenient to allow that a body is part of itself. This is a mere question of how you draw the definition. With this understanding, the relation is reflexive. Finally, if  $a$  is part of  $b$ , and  $b$  is part of  $a$ , then  $a$  and  $b$  must be identical. These properties of 'whole and part' are not fresh assumptions, they follow from the logical form of our definition.

One assumption has to be made if we assume the ideal infinite divisibility of space. Namely, we assume that every class of perceptions which is an extended body contains other classes of perceptions which are extended bodies diverse from itself. This assumption makes rather a large draft on the theory of ideal perceptions. Geometry vanishes unless in some form you make it. The assumption is not peculiar to my exposition.

It is then possible to define what we mean by a point. A point is the class of extended objects which, in ordinary language, contain that point. The definition, without presupposing the idea of a point, is rather elaborate, and I have not now time for its statement.

The advantage of introducing points into Geometry is the simplicity of the logical expression of their mutual relations. For science, simplicity of definition is of slight importance, but simplicity of mutual relations is essential. Another example of this law is the way physicists and chemists have dissolved the simple idea of an extended body, say of a chair, which a child understands, into a bewildering notion of a complex dance of molecules and atoms and electrons and waves of light. They have thereby gained notions with simpler logical relations.

Space as thus conceived is the exact formulation of the properties of the apparent space of the common-sense world of experience. It is not necessarily the best mode of conceiving the space of the physicist. The one essential requisite is that the correspondence between the common-sense world in its space and the physicists' world in its space should be definite and reciprocal.

I will now break off the exposition of the function of logic in connection with the science of natural phenomena. I have endeavoured to exhibit it as the organising principle, analysing the derivation of the concepts from the immediate phenomena, examining the structure of the general propositions which are the assumed laws of nature, establishing their relations to each other in respect to reciprocal implications, deducing the phenomena we may expect under given circumstances.

Logic, properly used, does not shackle thought. It gives freedom and, above all, boldness. Illogical thought hesitates to draw conclusions, because it never knows either what it means, or what it assumes, or how far it trusts its own assumptions, or what will be the effect of any modification of assumptions. Also the mind untrained in that part of constructive logic which is relevant to the subject in hand will be ignorant of the sort of conclusions which follow from various sorts of assumptions, and will be correspondingly dull in divining the inductive laws. The fundamental training in this relevant logic is, undoubtedly, to ponder with an active mind over the known facts of the case, directly observed. But where elaborate deductions are possible, this mental activity requires for its full exercise the direct study of the abstract logical relations. This is applied mathematics.

Neither logic without observation, nor observation without logic, can move one step in the formation of science. We may conceive humanity as engaged in an internecine conflict between youth and age. Youth is not defined by years, but by the creative impulse to make something. The aged are those who, before all things, desire not to make a mistake. Logic is the olive branch from the old to the young, the wand which in the hands of youth has the magic property of creating science.

The following business was then transacted :—

1. *Discussion on Gravitation.* Opened by E. CUNNINGHAM.  

---
2. *Report on the Determination of Gravity at Sea.*  
 See Appendix p. 549.  

---
3. *Efficiency of Sunspots in relation to Terrestrial Magnetic Phenomena.*<sup>1</sup> By Rev. A. L. CORTIE, S.J.  

---
4. *Report of the Seismological Committee.*—See Reports, p. 29.  

---
5. *The Mean Distances of Stars of different Magnitudes.*<sup>2</sup>  
 By Sir F. W. DYSON, F.R.S.  

---

THURSDAY, SEPTEMBER 7.

The following business was transacted :—

1. *Discussion on Osmotic Pressure.* Opened by Professor A. W. PORTER, F.R.S.  

---
2. *The Measurement of Time.* By Professor H. II. TURNER, F.R.S.<sup>3</sup>  

---
3. *Ionisation Potential.* By Professor J. C. McLENNAN.

FRIDAY, SEPTEMBER 8.

The following Papers were received :—

1. *X-Ray Spectra of the Elements.*<sup>4</sup> By Sir E. RUTHERFORD, F.R.S.  

---
2. *Propagation of a Signal in a Dispersive Medium.*  
 By Professor T. H. HAVELOCK, F.R.S.

DEPARTMENT OF GENERAL PHYSICS.

3. *Can the Frequencies of Spectral Lines be represented as a Function of their Order?*<sup>5</sup> By Professor W. H. HICKS, F.R.S.  

---

<sup>1</sup> See *Monthly Notices, R.A.S.*, vol. lxxvi., pp. 15-16, 631-634. *Ibid.*, vol. lxxiii., pp. 539-543.

<sup>2</sup> Published in *Monthly Notices, R.A.S.*, vol. lxxvii., No. 1.

<sup>3</sup> Published in *The Observatory*, vol. xxxix., p. 419-425.

<sup>4</sup> See *Engineering*, October 6, 1916, p. 320.

<sup>5</sup> See the *Astrophysical Journal*, November 1916, vol. xlv., p. 229.

4. *Measurement of the Energy in Spectral Lines.*<sup>6</sup>  
By Dr. R. T. BEATTY.

DEPARTMENT OF MATHEMATICS.

5. *Oscillating and Asymptotic Series.* By Professor G. N. WATSON.

The author, after referring to the work of Cauchy and Abel, gave an account of the more recent researches of Poincaré, Borel, Cesàro, and others. For references to these and other investigations on related topics the following may be consulted: Borel, *Leçons sur les Séries Divergentes*; Bromwich, *Infinite Series*; Whittaker and Watson, *Modern Analysis*.

6. *Suggestions for the Practical Treatment of the Standard Cubic Equation and a Contribution to Substitution Theory.*<sup>7</sup> By Professor R. W. GENESE.

7. *Note on a Problem of Boltzmann's and its Relation to the Theory of Radiation.* By Dr. H. R. HASSÉ.

8. *Report on the Calculation of Mathematical Tables.*  
See Reports, p. 59.

<sup>6</sup> See *Phil. Mag.*, February 1917.

<sup>7</sup> See *Mathematical Gazette*, March 1917.

## SECTION B.—CHEMISTRY.

PRESIDENT OF THE SECTION: Professor G. G. HENDERSON,  
D.Sc., LL.D., F.R.S.

WEDNESDAY, SEPTEMBER 6.

The President delivered the following Address:—

FOR the third time in succession the Section meets under the shadow of the war cloud, but there is some slight consolation for the indescribable suffering and sorrow which have been imposed upon millions of our fellow creatures in the hope and belief that this cloud also may have a silver lining. It is perhaps no exaggeration to say that nothing less than such an upheaval of existing habits and traditions as has been caused by the war would have sufficed to arouse the British nation from the state of apathy towards science with which it has been fatuously contented in the past. Now, however, the sleeper has at least stirred in his slumber. The Press bears witness, through the appearance of innumerable articles and letters, that the people of this country, and even the politicians, have begun to perceive the dangers which will inevitably result from a continuance of their former attitude, and to understand that in peace, as in war, civilisation is at a tremendous disadvantage in the struggle for existence unless armed by science, and that the future prosperity of the Empire is ultimately dependent upon the progress of science, and very specially of chemistry. If, as one result of the war, our people are led to appreciate the value of scientific work, then perhaps we shall not have paid too high a price, high although the price must be. As concerns our own branch of science, we cannot rest satisfied with anything less than full recognition of the fact that chemistry is a profession of fundamental importance, and that the chemist is entitled to a position in no respect inferior to that of a member of any of the other learned professions.

Reference to the Annual Reports of the Association shows that former Presidents of the Section have availed themselves to the full of the latitude permitted in the choice of a subject for their Address, and that some have even established the precedent of dispensing with an Address altogether. On the present occasion a topic for discussion seems to be clearly indicated by the circumstances in which we stand, because, since the outbreak of the war, chemists have been giving more earnest consideration than before to the present position and future prospects of the chemical industry of this country. It will, therefore, not be inappropriate if I touch upon some aspects of this question, even although unable to add much to what is, or ought to be, common knowledge.

The period which has elapsed since the last meeting of the Section in Newcastle has witnessed truly remarkable progress in every branch of pure and applied chemistry. For fully fifty years previous to that meeting the attention of the great majority of chemists had been devoted to organic chemistry, but since 1885 or thereabouts, whilst the study of the compounds of carbon has been pursued with unflagging energy and success, it has no longer so largely monopolised the activities of investigators. Interest in the other elements, which had been to some extent neglected on account of the fascinations of carbon, has been revived with the happiest results, for not only has our knowledge of these elements been greatly extended, but their number also has been notably increased by the discovery of two groups of simple substances possessed of new and remarkable properties—the inert gases of the argon family and the radio-active elements. In addition, the bonds between mathematics and physics on the one hand and chemistry on the other have been drawn



closer, with the effect that the department of our science known as physical chemistry has now assumed a position of first-rate importance. With the additional light provided by the development and application of physico-chemical theory and methods, we are beginning to gain some insight into such intricate problems as the relation between physical properties and chemical constitution, the structure of molecules and even of atoms, and the mechanics of chemical change; our outlook is being widened, and our conceptions rendered more precise. Striking advances have also been made in other directions. The extremely difficult problems which confront the bio-chemist are being gradually overcome, thanks to the indefatigable labours of a band of highly skilled observers, and the department of biological chemistry has been established on a firm footing through the encouraging results obtained within the period under review. Further, within the last few years many of our ideas have been subjected to a revolutionary change through the study of the radio-active elements, these elusive substances which occur in such tantalisingly minute quantities, and of which some appear so reluctant to exist in a free and independent state that they merge their identity in that of another and less retiring relative within an interval of time measured by seconds. In truth, if a Rip Van Winkle among chemists were to awake now after a slumber of thirty years, his amazement on coming into contact with the chemistry of to-day would be beyond words.

The more purely scientific side of our science can claim no monopoly in progress, for applied chemistry, in every department, has likewise advanced with giant strides, mainly of course through the application of the results of scientific research to industrial purposes. An attempt to sketch in the merest outline the recent development of applied chemistry would, I fear, exhaust your patience, but I may indicate in passing some of the main lines of advance. Many of the more striking results in the field of modern chemical industry have been obtained by taking advantage of the powers we now possess to carry out operations economically both at very high and at very low temperatures, and by the employment on the manufacturing scale of electrolytic and catalytic methods of production. Thanks largely to the invention of the dynamo, the technologist is now able to utilise electrical energy both for the production of high temperatures in the different types of electric furnace and for electrolytic processes of the most varied description. Among the operations carried out with the help of the electric furnace may be mentioned the manufacture of graphite, silicon, and phosphorus; of chromium and other metals; of carbides, silicides, and nitrides; and the smelting and refining of iron and steel. Calcium carbide claims a prominent place in the list, in the first place because of the ease with which it yields acetylene, which is not only used as an illuminant, and, in the oxy-acetylene burner, as a means of producing a temperature so high that the cutting and welding of steel is now a comparatively simple matter, but also promises to serve as the starting-point for the industrial synthesis of acetaldehyde and many other valuable organic compounds. Moreover, calcium carbide is readily converted in the electric furnace into calcium cyanamide, which is employed as an efficient fertiliser in place of sodium nitrate or ammonium sulphate, and as a source of ammonia and of alkali cyanides. Among the silicides carborundum is increasingly used as an abrasive and a refractory material, and calcium silicide, which is now a commercial product, forms a constituent of some blasting explosives. The Serpek process for the preparation of alumina and ammonia, by the formation of aluminium nitride from beauxite in the electric furnace and its subsequent decomposition by caustic soda, should also be mentioned. Further, the electric furnace has made possible the manufacture of silica apparatus of all kinds, both for the laboratory and the works, and of alundum ware, also used for operations at high temperature. Finally, the first step in the manufacture of nitric acid and of nitrites from air, now in operation on a very large scale, is the combustion of nitrogen in the electric arc.

In other industrial operations the high temperature which is necessary is obtained by the help of the oxy-hydrogen or the oxy-acetylene flame, the former being used, amongst other purposes, in a small but I believe profitable industry, the manufacture of synthetic rubies, sapphires, and spinels. Also, within a comparatively recent period, advantage has been taken of the characteristic

properties of aluminium, now obtainable at a moderate price, in the various operations classed under the heading aluminothermy, the most important being the reduction of refractory metallic oxides, although, of course, thermite is useful for the production of high temperatures locally.

The modern methods of liquefying gases, which have been developed within the period under review, have rendered possible research work of absorbing interest on the effect of very low temperatures on the properties and chemical activity of many substances, and have been applied, for instance, in separating from one another the members of the argon family, and in obtaining ozone in a state of practical purity. Moreover, industrial applications of these methods are not lacking, amongst which I may mention the separation of nitrogen and oxygen from air, and of hydrogen from water-gas—processes which have helped to make these elements available for economic use on the large scale.

Electrolytic methods are now extensively employed in the manufacture of both inorganic and organic substances, and older processes are being displaced by these modern rivals in steadily increasing number. It is sufficient to refer to the preparation of sodium, magnesium, calcium, and aluminium, by electrolysis of fused compounds of these metals; the refining of iron, copper, silver, and gold; the extraction of gold and nickel from solution; the recovery of tin from waste tin-plate; the preparation of caustic alkalis (and simultaneously of chlorine), of hypochlorites, chlorates, and perchlorates, of hydrosulphites, of permanganates and ferricyanides, of persulphates and percarbonates; the regeneration of chromic acid from chromium salts; the preparation of hydrogen and oxygen. As regards organic compounds, we find chiefly in use electrolytic methods of reduction, which are specially effective in the case of many nitro compounds, and of oxidation, as for instance the conversion of anthracene into anthraquinone. At the same time a number of other compounds, for example iodoform, are also prepared electrolytically.

Within recent years there have been great advances in the application of catalytic methods to industrial purposes. Some processes of this class have, of course, been in use for a considerable time, for example the Deacon chlorine process and the contact method for the manufacture of sulphuric acid, whilst the preparation of phthalic anhydride (largely used in the synthesis of indigo and other dyestuffs), by the oxidation of naphthalene with sulphuric acid with the assistance of mercuric sulphate as catalyst, is no novelty. More recent are the contact methods of obtaining ammonia by the direct combination of nitrogen and hydrogen, and of oxidising ammonia to nitric acid—both of which are said to be in operation on a very large scale in Germany. The catalytic action of metals, particularly nickel and copper, is utilised in processes of hydrogenation—for example, the hardening of fats, and of dehydrogenation, as in the preparation of acetaldehyde from alcohol, and such metallic oxides as alumina and thoria can be used for processes of dehydration—*e.g.*, the preparation of ethylene or of ether from alcohol. Other catalysts employed in industrial processes are titanous chloride in electrolytic reductions and cerous sulphate in electrolytic oxidations of carbon compounds, gelatine in the preparation of hydrazine from ammonia, sodium in the synthesis of rubber, &c.

Other advances in manufacturing chemistry include the preparation of a number of the rarer elements and their compounds, which were hardly known thirty years ago, but which now find commercial applications. Included in this category are titanium, vanadium, tungsten, and tantalum, now used in metallurgy or for electric-lamp filaments; thoria and ceria in the form of mantles for incandescent lamps; pyrophoric alloys of cerium and other metals; zirconia, which appears to be a most valuable refractory material; and compounds of radium and of mesothorium, for medical use as well as for research. Hydrogen, together with oxygen and nitrogen, are in demand for synthetic purposes, and the first also for lighter-than-air craft. Ozone is considerably used for sterilising water and as an oxidising agent, for example in the preparation of vanillin from isoeugenol, and hydrogen peroxide, now obtainable very pure in concentrated solution, and the peroxides of a number of the metals are also utilised in many different ways. The per-acids—perboric, percarbonic, and persulphuric—or their salts are employed for oxidising and bleaching purposes, and sodium hydrosulphite is much in demand as a reducing agent—*e.g.*, in

dyeing with indigo. Hydroxylamine and hydrazine are used in considerable quantity, and the manufacture of cyanides by one or other of the modern methods has become quite an important industry, mainly owing to the use of the alkali salts in the cyanide process of gold extraction. These remarkable compounds the metallic carbonyls have been investigated, and nickel carbonyl is employed on the commercial scale in the extraction of the metal. Fine chemicals for analysis and research are now supplied, as a matter of course, in a state of purity rarely attained a quarter of a century ago.

In the organic chemical industry similar continued progress is to be noted. Accessions are constantly being made to the already enormous list of synthetic dyes, not only by the addition of new members to existing groups, but also by the discovery of entirely new classes of tinctorial compounds; natural indigo seems doomed to share the fate of alizarine from madder, and to be ousted by synthetic indigo, of which, moreover, a number of useful derivatives are also made. Synthetic drugs of all kinds—antipyrine and phenacetin, sulphonal and veronal, novocain and  $\beta$ -eucaine, salol and aspirin, piperazine and adrenaline, atoxyl and salvarsan—are produced in large quantities, as also are many synthetic perfumes and flavouring materials, such as ionone, heliotropine, and vanillin. Cellulose in the form of artificial silk is much used as a new textile material, synthetic camphor is on the market, synthetic rubber is said to be produced in considerable quantity; and the manufacture of materials for photographic work and of organic compounds for research purposes is no small part of the industry. However, it would serve no useful purpose to extend this catalogue, which might be done almost indefinitely.

British chemists are entitled to regard with satisfaction the part which they have taken in the development of scientific chemistry during the last three decades, as in the past, but with respect to the progress of industrial chemistry it must be regretfully admitted that, except in isolated cases, we have failed to keep pace with our competitors. Consider a single example. Although there still remain in South America considerable deposits of sodium nitrate which can be worked at a profit, it is clear that sooner or later other sources of nitric acid must be made available. The synthetic production of nitric acid from the air is now a commercial success; several different processes are in operation abroad, and Germany is reported to be quite independent of outside supplies. Electrical energy, upon the cost of which the success of the process largely depends, can be produced in this country at least as cheaply as in Germany, and yet we have done nothing in the matter, unless we count as something the appointment of a committee to consider possibilities. This case is only too typical of many others. A number of different causes have contributed to bring about this state of affairs, and the responsibility for it is assigned by some to the Government, by others to the chemical manufacturers, and by still others to the professors of chemistry. I think, however, it will be generally admitted that the root of the matter is to be found in the general ignorance of and indifference to the methods and results of scientific work which characterises the people of this country. For many years past our leaders in science have done all that lay in their power to awaken the country to the inevitable and deplorable results of this form of 'sleeping sickness,' but hitherto their reception has been much the same as that accorded to the hero of 'The Pilgrim's Progress,' as depicted in the following passage:—

'He went on thus, even until he came at a bottom where he saw, a little out of the way, three Men fast asleep with Fetters upon their heels.

'The name of the one was *Simple*, another *Sloth*, and the third *Presumption*.

'Christian, then seeing them in this case, went to them, if peradventure he might awaken them. And cried, You are like them that sleep on the top of a Mast, for the Dead Sea is under you, a Gulf that hath no bottom. Awake therefore and come away; be willing also, and I will help you off with your irons. He also told them, If he that goeth about like a *Roaring Lion* comes by, you will certainly become a prey to his teeth.

'With that they lookt upon him, and began to reply in this sort: *Simple* said, *I see no danger*; *Sloth* said, *Yet a little more sleep*; and *Presumption* said, *Every Vat must stand upon his own bottom*. And they lay down to sleep again, and *Christian* went on his way.'

I believe that a brighter day is dawning, and that, if only we rise to the occasion *now*, chemistry in this country will attain the position of importance which is its due. Meantime it is of no avail to lament lost opportunities or to indulge in unprofitable recrimination; on the contrary, it should be our business to find a remedy for the 'arrested development' of our chemical industry, and the task of establishing remedial measures should be taken in hand by the State, the universities and the chemical manufacturers themselves. As regards another very large group of interested persons, the consumers of chemical products, or in other words the nation as a whole, it is surely not too much to expect that they have been taught by the course of events since the outbreak of the war the folly of depending solely upon foreign and possibly hostile manufacturers, even although fiscal and other advantages may enable the alien to undersell the home producer. Considering that the future prosperity of the Empire depends largely upon the well-being of its chemical industries, it is simply suicidal to permit these to be crippled or even crushed out of existence by competition on unequal terms.

The Government has taken a most significant step in advance by appointing an Advisory Council for Scientific and Industrial Research and providing it with funds; incidentally, in so doing, it has recognised the past failure of the State to afford adequate support to scientific work. The Advisory Council has lost no time in getting to work and has already taken steps to allocate grants in support of a number of investigations of first-rate importance to industry. In order to be in a position to do justice to the branches of industry concerned in proposed researches which have been submitted by institutions and individuals it has decided to appoint standing committees of experts and has already constituted strong Committees in Mining, Metallurgy, and in Engineering; a Committee in Chemistry will no doubt be appointed in due course. The Council also makes the gratifying intimation that the training of an adequate supply of research workers will be an important part of its work.

It is safe to prophesy that the money expended by the Advisory Council will sooner or later yield a goodly return, and this justifies the hope that the Government will not rest satisfied with their achievement, but will take further steps in the same direction. This desire for continued action finds strong support in the Recommendations made by a Sub-Committee of the Advisory Committee to the Board of Trade on Commercial Intelligence, which was appointed to report with respect to measures for securing the position, after the war, of certain branches of British industry. Of these recommendations I quote the following:—

1. *Scientific Industrial Research and Training.* (a) Larger funds should be placed at the disposal of the new Committee of the Privy Council, and also of the Board of Education, for the promotion of scientific and industrial training. (b) The universities should be encouraged to maintain and extend research work devoted to the main industry or industries located in their respective districts, and manufacturers engaged in these industries should be encouraged to co-operate with the universities in such work, either through their existing trade associations or through associations specially formed for the purpose. Such associations should bring to the knowledge of the universities the difficulties and needs of the industries, and give financial and other assistance in addition to that afforded by the State. In the case of non-localised industries trade associations should be advised to seek, in respect of centres for research, the guidance of the Advisory Committee of the Privy Council. (c) An authoritative record of consultant scientists, chemists and engineers, and of persons engaged in industrial research, should be established and maintained by some suitable Government Department for the use of manufacturers only.

2. *Tariff Protection.* Where the national supply of certain manufactured articles which are of vital importance to the national safety or are essential to other industries has fallen into the hands of manufacturers or traders outside this country, British manufacturers ready to undertake the manufacture of such articles in this country should be afforded sufficient tariff protection to enable them to maintain such production after the war.' (It is also recommended by the Sub-Committee that in view of the threatened dumping of stocks which may be accumulated in enemy countries, the Government should take

such steps as would prevent the position of industries, likely to be affected, being endangered after the war.)

'3. *Patents.* (a) The efforts which have been made to secure uniformity of Patent Law throughout the Empire should be continued. (b) The provisions of the law as to the compulsory working of patents in the United Kingdom should be more rigorously enforced, and inspectors should be appointed to secure that such working is complete and not only partial.'

The adoption by the Government of these weighty recommendations would go far to establish British chemical industry on a secure basis, and would undoubtedly lead to the expansion of already existing branches and the establishment of new ones. Meanwhile, the Australian Government has set an example which might be followed with great advantage. Shortly after the British scheme for the development of scientific and industrial research under the auspices of the Advisory Council had been made public, the Prime Minister of Australia determined to do still more for the Commonwealth, with the object of making it independent of German trade and manufactures after the conclusion of the war. He therefore appointed a committee representative of the State Scientific Departments, the universities, and industrial interests, and within a very short period the committee produced a scheme for the establishment of a Commonwealth Institute of Science and Industry. The Institute is to be governed by three directors, two of whom will be scientific men of high standing, while the third will be selected for proved ability in business. The directors are to be assisted by an Advisory Council composed of nine representatives of science and of industry; these representatives are to seek information, advice, and assistance from specialists throughout Australia. The chief functions of the Institute are (1) To ascertain what industrial problems are most pressing and most likely to yield to scientific experimental investigation, to seek out the most competent men to whom such research may be entrusted, and to provide them with all the necessary appliances and assistance. (2) To build up a bureau of scientific and industrial information, which shall be at the service of all concerned in the industries and manufactures of the Commonwealth. (3) To erect, staff, and control special research laboratories, the first of which will probably be a physical laboratory somewhat on the lines of our National Physical Laboratory. Other functions of the Institute are the co-ordination and direction of research and experimental work with a view to the prevention of undesirable overlapping of effort, the recommendation of grants of the Commonwealth Government in aid of pure scientific research in existing institutions, and the establishment and award of industrial research fellowships.

This admirable scheme is more comprehensive and more generous than that of our Government, but it could be rivalled without much difficulty. We already possess an important asset in the National Physical Laboratory, and there now exists the Advisory Council with its extensive powers and duties. What is lacking in our scheme, so far as chemistry is concerned, could be made good, firstly, by providing the Advisory Council with much larger funds, and, secondly, by the establishment of a National Chemical Laboratory—an institute for research in pure and applied chemistry—or by assisting the development of research departments in our universities and technical colleges (as is now being done in America), or, better still, by moving in both directions. With respect to the second alternative, I do not mean to suggest that research work is neglected in the chemistry departments of any of our higher institutions; what I plead for is the provision of greater facilities for the prosecution of investigation not only in pure but also in applied chemistry. As things are at present, the professors and lecturers are for the most part so much occupied in teaching and in administration as to be unable to devote time uninterruptedly to research work, which demands above all things continuity of effort. The ideal remedy would be the institution of research professorships, but, failing this, the burden of teaching and administrative work should be lightened by appointing larger staffs.

It has been suggested by Dr. Forster that the State could render assistance to chemical industry in another way, namely, by the formation of a Chemical Intelligence Department of the Board of Trade, which should be concerned with technical, commercial, and educational questions bearing upon the industry.

Under the first head the proposed Department would have the duty (a) of collecting, tabulating, and distributing all possible information regarding chemical discoveries, patents, and manufacturing processes, and (b) of presenting problems for investigation to research chemists, of course under proper safeguards and with suitable remuneration. The more strictly commercial side of the Department's activities would be concerned with the classification of the resources of the Empire as regards raw materials, and of foreign chemical products in respect of distribution throughout the world, with ruling prices, tariffs, cost of transport, and if possible cost of production. On the educational side it is suggested that the Department should collect data regarding opportunities for chemical instruction and research in various parts of the Empire, and should consider possible improvements and extensions of these. The Department would of course be in charge of a highly trained chemist, with a sufficient number of chemical assistants.

This proposal, which has been widely discussed and on the whole very favourably received by chemists, has much to recommend it; to mention only one point, the unrivalled resources of the Board of Trade would facilitate the acquisition of information which might otherwise be difficult to obtain, or which would not be disclosed except to a Government Department. The principal objections which have been raised are based upon the fear that the proposed Department, however energetic and enterprising it might be at the start, would soon be so helplessly gagged and bound down by departmental red tape as to become of little or no service. This danger, however, could be obviated to a great extent by the institution of a strong Advisory Committee, representative of and elected by the Societies concerned with the different branches of chemistry, which would keep closely in touch with the Chemical Intelligence Department on the one hand and with the industry on the other, and which would act as adviser of the permanent scientific staff of the Department. There is, I fear, little chance of seeing Dr. Forster's proposal carried into effect unless all the Societies concerned move actively and unitedly in the matter; they must do the pioneer work and must submit a definite scheme to the Government, if the desired result is to be attained. In the not improbable contingency that the Board of Trade will decline to take action, I trust that the scheme for the establishment of an Information Bureau—on lines similar to but somewhat less wide-reaching than those which I have just indicated—which has been under the careful consideration of the Council of the Society of Chemical Industry, will be vigorously prosecuted. Difficulties, chiefly financial, stand in the way, but these are not insuperable, especially if the sympathy and support of the Government can be enlisted.

Unless the conditions and methods which have ruled in the past are greatly altered it is hardly possible to hope that the future prospects of our chemical industry will be bright; it is essential that the representatives of the industry should organise themselves in their own interest and co-operate in fighting the common enemy. More than ever is this the case when, as we are informed, three different groups of German producers of dyes, drugs, and fine chemicals, who own seven large factories, have formed a combination with a capital of more than 11,000,000*l.*, and with other assets of very great value in the shape of scientific, technical, and financial efficiency. Hence it is eminently satisfactory to be able to record the active progress of a movement, originated by the Chemical Society, which has culminated in the formation of an Association of British Chemical Manufacturers. The main objects of the Association are to promote co-operation between British chemical manufacturers; to act as a medium for placing before the Government and Government officials the views of manufacturers upon matters affecting the chemical industry; to develop technical organisation and promote industrial research; to keep in touch with the progress of chemical knowledge and to facilitate the development of new British industries and the extension of existing ones; and to encourage the sympathetic association of British manufacturers with the various universities and technical colleges.

Needless to say, the progress of this important movement will be assisted by everyone who is interested, either directly or indirectly, in the welfare of our chemical industry, and, moreover, the support of the scientific societies will

not be lacking, for, as the result of a conference convened by the President and Council of the Royal Society, a Conjoint Board of Scientific Societies has been constituted, for the furtherance of the following objects:—Promoting the co-operation of those interested in pure or applied science; supplying a means whereby scientific opinion may find effective expression on matters relating to science, industry, and education; taking such action as may be necessary to promote the application of science to our industries and to the service of the nation; and discussing scientific questions in which international co-operation seems advisable.

In an Address given to the Society of Chemical Industry last year, I indicated another way in which chemical manufacturers can help themselves and at the same time promote the interests of chemistry in this country. In the United States of America individual manufacturers, or associations of manufacturers, have shown themselves ready to take up the scheme originated by the late Professor Duncan for the institution of industrial research scholarships tenable at the universities or technical colleges, and the results obtained after ten years' experience of the working of this practical method of promoting co-operation between science and industry have more than justified the anticipations of its originator. The scheme is worthy of adoption on many grounds, of which the chief are that it provides definite subjects for technical research to young chemists qualified for such work, that it usually leads to positions in factories for chemists who have proved their capacity through the work done while holding scholarships, and that it reacts for good on the profession generally, by bringing about that more intimate intercourse between teachers and manufacturers which is so much to be desired.

In this connection the recent foundation of the Willard Gibbs Chair of research in pure chemistry at the University of Pittsburgh is extremely significant, for it shows that even in such a purely industrial community as Pittsburgh it is recognised that the most pressing need of the day is the endowment of chemical research and the creation of research professorships. Mr. A. P. Fleming, who recently made a tour of inspection of research laboratories in the United States, points to the amount of work done by individual firms and the increased provision now being made for research in universities and technical institutions. He reports that at the present time there are upwards of fifty corporations having research laboratories, costing annually from 20,000*l.* to 100,000*l.* for maintenance, and states that 'some of the most striking features of the research work in America are the lavish manner in which the laboratories have been planned, which in many cases enables large scale operations to be carried out in order to determine the best possible methods of manufacturing any commodity developed or discovered in the laboratories; the increasing attention given in the research laboratories to pure science investigation, this being, in my opinion, the most important phase of industrial research; and the absorption of men who have proven their capacity for industrial research in such places as the Mellon Institute, the Bureau of Standards, &c., by the various industries in which they have taken scientific interest.' It is evidently the view of American manufacturers that industrial research can be made to pay for itself, and that to equip and maintain research laboratories is an excellent investment.

It cannot be too often reiterated that no branch of chemical industry can afford to stand still, for there is no finality in manufacturing processes; all are capable of improvement, and for this, as well as for the discovery and the application of new processes, the services of the trained chemist are essential. Hence the training of chemists for industrial work is a matter of supreme importance. We may therefore congratulate ourselves that the opportunities for chemical instruction in this country are immensely greater than they were thirty years ago. The claims of chemistry to a leading position have been recognised by all our universities, even the most ancient, by the provision of teaching staffs, laboratories, and equipment on a fairly adequate if not a lavish scale, and in this respect many of the technical colleges fall not far behind. The evening classes conducted in a large number of technical institutions are hardly fitted to produce fully trained chemists, if only because lack of the necessary time prevents the student from obtaining that prolonged practice in the labora-

tory which cannot be dispensed with, unless indeed he is prepared to go through a course of study extending over many years. At the same time these evening classes play a most important part, firstly in disseminating a knowledge of chemistry throughout the country, and secondly in affording instruction of a high order in special branches of applied chemistry. Finally, in a large and increasing number of schools a more or less satisfactory introduction to the science is given by well-qualified teachers. With our national habit of self-depreciation we are apt to overlook the steady progress which has been made, but at the same time I do not suggest that there is no room for improvement of our system of training chemists. Progress in every department of industrial chemistry is ultimately dependent upon research, and therefore a sufficient supply of chemists with practical knowledge and experience of the methods of research is vital. This being so, it is an unfortunate thing that so many students are allowed to leave the universities in possession of a science degree but without any experience in investigation. The training of the chemist, so far as that training can be given in a teaching institution, must be regarded as incomplete unless it includes some research work, not, of course, because every student has the mental gifts which characterise the born investigator, but rather because of the inestimable value of the experience gained when he has to leave the beaten track and to place more dependence upon his own initiative and resource. Consequently one rejoices to learn that at the University of Oxford no candidate can now obtain an Honours degree without having produced evidence that he has taken part in original research, and that the General Board of Studies at Cambridge has also made proposals which, if adopted, will have the effect of encouraging systematic research work. Perhaps it is too much to expect that practice in research will be made an indispensable qualification for the ordinary degree; failing this, and indeed in every case, promising students should be encouraged, by the award of research scholarships, to continue their studies for a period of at least two years after taking the B.Sc. degree, and to devote that time to research work which would qualify for a higher degree. In this connection an excellent object-lesson is at hand, for the output of research work from the Scottish Universities has very greatly increased since the scheme of the Carnegie Trust for the institution of research scholarships has come into operation. Thanks to these scholarships, numbers of capable young graduates, who otherwise for the most part would have had to seek paid employment as soon as their degree courses were completed, have been enabled to devote two or more years to research work. Of course it must be recognised that not every chemist has the capacity to initiate or inspire investigation, and that no amount of training, however thorough and comprehensive, will make a man an investigator unless he has the natural gift. At the same time, whilst only the few are able to originate really valuable research work, a large army of disciplined men who have had training in the methods of research is required to carry out experimentally the ideas of the master mind. Moreover, there is ample scope in industrial work for chemists who, although not gifted with initiative as investigators, are suitably equipped to supervise and control the running of large-scale processes, the designing of appropriate plant, the working out on the manufacturing scale of new processes or the improvement of existing ones—men of a thoroughly practical mind, who never lose sight of costs, output, and efficiency, and who have a sufficient knowledge of engineering to make their ideas and suggestions clear to the engineering expert. Further, there has to be considered the necessity for the work of the skilled analyst in the examination of raw materials and the testing of intermediate and finished products, although much of the routine work of the industrial laboratory will advisedly be left in the hands of apprentices working under the control of the chemist. Lastly, for the buying and selling of materials there should be a demand for the chemist with the commercial faculty highly developed. There is, indeed, in any large industrial establishment room for chemists of several different types, but all of these should have had the best possible training, and it must be the business of our higher teaching institutions to see that this training is provided.

On more than one occasion I have expressed the opinion that every chemist who looks forward to an industrial post should receive in the course of his training a certain amount of instruction in chemical engineering, by means of lectures



and also of practical work in laboratories fitted out for the purpose. The practicability of this has been proved in more than one teaching institution, and experience has convinced me that chemists who have had such a course are generally more valuable in a works—whether their ultimate destination is the industrial research laboratory or the control of manufacturing operations—than those who have not had their studies directed beyond the traditional boundaries of pure chemistry. (I used the word 'traditional' because to my mind there is no boundary line between the domains of pure and of applied chemistry.) A course in chemical engineering, preferably preceded by a short course in general engineering and drawing, must, however, be introduced as a *supplement to*, and not as a *substitute for*, any part of the necessary work in pure chemistry, and consequently the period of undergraduate study will be lengthened if such a course is included; this is no disadvantage, but quite the contrary. I am glad to say that the University of Glasgow has recently instituted a degree in Applied Chemistry, for which the curriculum includes chemical engineering in addition to the usual courses in chemistry, and I hope that a place will be found for this subject by other universities.

On the whole, there is not much fault to be found with the training for chemists supplied by the universities and technical colleges, but there is still room for improvements which could and would be carried out if it were not that the scientific departments of these institutions are as a rule hampered by lack of funds. The facilities for practical instruction with respect to accommodation and equipment are generally adequate, but, on the other hand, the *personnel* could with advantage be largely increased, and at least the junior members of the staffs are miserably underpaid. It would doubtless be regarded as insanity to suggest that a scientific man, however eminent, should receive more than a fraction of the salary to which a music-hall 'artiste' or a lawyer politician can aspire; but if the best brains in the country are to be attracted towards science, as they ought to be, some greater inducement than a mere living wage should be held out. Hence no opportunity should be lost of impressing upon the Government the necessity for increasing the grants to the scientific departments of our higher teaching institutions, and for the provision of research scholarships. It is much to be desired also that wealthy men in this country should take an example from America and acquire more generally the habit of devoting some part of their means to the endowment of higher education. The private donations for science and education made in the United States during the last forty-three years amount to the magnificent sum of 117,000,000*l.*, and recently the average annual benefactions for educational purposes total nearly 6,000,000*l.* Of course there are few, if any, of the universities and colleges in this country which are not deeply indebted to the foresight and generosity of private benefactors, but the lavish scale on which funds are provided in America leads to a certain feeling of admiring envy.

After all, the chief difficulty which confronts those who are eager for progress in educational matters is that so many of our most famous schools are still conducted on mediæval lines, in the sense that the 'education' administered is almost wholly classical. Consequently, 'though science enters into every part of modern life, and scientific method is necessary for success in all undertakings, the affairs of the country are in the hands of legislators who not only have little or no acquaintance with the fundamental facts and principles signified by these aspects of knowledge, but also do not understand how such matters can be used to strengthen and develop the State. Our administrative officials are also mostly under the same disabilities, on account of their want of a scientific training. They are educated at schools where science can receive little encouragement, and they do not take up scientific subjects in the examinations for the Civil Service, because marks can be much more easily obtained by attention to Latin and Greek; and the result of it all is that science is usually treated with indifference, often with contempt, and rarely with intelligent appreciation by the statesmen and members of the public services whose decisions and acts largely determine the country's welfare. The defects of a system which places the chief power of an organisation which needs understanding of science in every department in the hands of people who have not

received any training in scientific subjects or methods are obvious.'<sup>1</sup> The remedy is also obvious.

Here, again, the prospects are now brighter than ever before, because the warnings and appeals of men of science have at last, and after many years, begun to bear fruit, or perhaps it would be more correct to say the lessons of the war have begun to make an impression on the powers that be. Within the last few weeks it has been intimated that the Government, giving ear to what has been uttered, incessantly and almost *ad nauseam*, with regard to British neglect of science, propose to appoint a committee to inquire into the position of science in our national system of education, especially in universities and secondary schools. The duty of the committee will be to advise the authorities how to promote the advancement of pure science, and also the interests of trade, industries, and professions dependent on the application of science, bearing in mind the needs of what is described as a liberal education. It is stated that the committee will include scientific men in whom the country will have confidence, some of those who appreciate the application of science to commerce and industry, and some who are able from general experience to correlate scientific teaching with education as a whole. I am sure that we may look forward with confidence to the recommendations of such a committee, and we shall hope, for the sake of our country, that their recommendations will be adopted and put in force with the least possible delay.

The following Papers were then read :—

1. *The Future of Organic Chemical Industry.* By F. H. CARR.
2. *The British Coal Tar Colour Industry in Peace and War.*  
By C. M. WHITTAKER.
3. *The Preparation of Chemicals for Laboratory Use.* By W. RINTOUL.

THURSDAY, SEPTEMBER 7.

The following business was transacted :—

1. *Joint Discussion with Section C on the Investigation of the Chemical and Geological Characters of different varieties of Coal, with a view to their most effective utilisation as fuel, and to the extraction of bye-products.*—See Section C, p. 395.
2. *The Papers read on Wednesday by Messrs. CARR, WHITTAKER, and RINTOUL were discussed.*
3. *Description and Exhibition of an Apparatus for Grinding Coal in Vacuo.* By Dr. P. PHILLIPS BEDSON.
4. *Papers by Dr. J. E. STEAD, F.R.S. :—*
  - (a) *On the Oxidation of Nickel Steel.*
  - (b) *On the Reduction of Solid Nickel and Copper Oxides by Solid Iron.*
  - (c) *On the Disruptive Effect of Carbon Monoxide at 400° to 500° C. on Wrought Iron.*

<sup>1</sup> 'Nature,' Feb. 10, 1916.

5. *A Modified Chlorination Process.* By Dr. J. A. SMYTHIE.
- 
6. *On the Stepped Ignition of Gases.* By Professor  
W. M. THORNTON.
- 
7. *Report on Dynamic Isomerism.*—See Reports, p. 130.
- 
8. *Report on the Transformation of Aromatic Nitroamines.*
- 
9. *Report on Plant Enzymes.*
- 
10. *Report on the Correlation of Crystalline Form with Molecular Structure.*
- 
11. *Report on the Study of Solubility Phenomena.*
- 
12. *Report on the Influence of Weather Conditions on the Amount of Nitrogen Acids in Rainfall and the Atmosphere.*—See Reports, p. 128.
- 
13. *Report on Non-aromatic Diazonium Salts.*
- 
14. *Second Report on the Botanical and Chemical Characters of the Eucalypts.*—See Reports, p. 201.
- 
15. *Report on the Absorption Spectra and Chemical Constitution of Organic Compounds.*—See Reports, p. 131.
- 
16. *Report on the Study of Hydroaromatic Substances.*
- 
17. *Report on the Natural Plant Products of Victoria.*
- 
18. *Report on the Utilisation of Brown Coal Bye-products.*  
See Reports, p. 205.
- 
19. *Report on Fuel Economy, the Utilisation of Coal, and Smoke Prevention.*—See Reports, p. 187.
- 

FRIDAY, SEPTEMBER 8.

*Joint Discussion with Section G on the Report of the Committee on Fuel Economy.*

---

## SECTION C.—GEOLOGY.

PRESIDENT OF THE SECTION: Professor W. S. BOULTON, D.Sc., F.G.S.

WEDNESDAY, SEPTEMBER 6.

The President delivered the following Address:—

WHEN I came to the serious consideration of a subject for this Address, two dominant thoughts emerged: the first, that we should be assembled here in Newcastle-on-Tyne, the heart of a great industrial community, where coal, the very life-blood of industry, has been raised for more than three centuries in ever-increasing amount—and of all minerals which our science has helped us to win from the earth for man's comfort and use, coal must assuredly take pride of place. My second thought was a reminder not of strenuous and peaceful achievement in the past, but of the fateful present and the grim and stressful future.

Those of us who have closely followed the opinions of the average educated man since the opening of the war must have been profoundly impressed with the revolution taking shape in his mind as to the attitude of the Government and the State towards science, and especially as to the relation of science to our industry and commerce. We now realise that this country, this Empire, has for the future vastly greater possibilities in the development and utilisation of its natural and industrial resources than in the past; that as far as possible it is imperative for our progress and safety that we become more self-contained, and less dependent upon the foreigner for the absolute necessities for our manufactures and industry. Chemists, engineers, and metallurgists have become keenly exercised as regards the application of their respective sciences, not only to the making of munitions of war, but to the advancement of industry after the war.

In these grave questionings, in this general stock-taking of science in its relation to industry and the State, what of our own particular science? Will geology take its rightful share in ministering to our material wants and in furthering the Empire's needs?

It has been the custom for the President of this Section to deal with some large, outstanding question of theoretic interest, as in the luminous and eloquent Address by Professor Cole last year. On this occasion I wish to deal with the present outlook of Economic Geology, more especially in this country.

If we attempt to compare the growth of applied geology in Britain with that, say, in the United States of America, or even in our great self-governing Dominions, or to appraise the knowledge of, and respect for, the facts and principles of geology as directly applicable to industry in these countries and in our own, or to compare the respective literatures on the subject, I think we shall have to confess that we have lagged far behind the position we ought by right of tradition and opportunities now to occupy. The vast natural resources of the countries I have named have doubtless stimulated a corresponding effort in their profitable development. But making due allowance for the fact that

Britain is industrially mature as compared with these youthful communities, we cannot doubt that in this special branch of geology, however splendid our advances in others, we have been outstripped by our kinsmen abroad.

To attempt an explanation of this comparative failure to apply effectively the resources of geology to practical affairs would demand a critical analysis of the whole position of science in relation to industry and education which is being so vigorously debated by public men to-day. It is unquestionably due, in no small measure, to our ignorance and neglect of, and consequent indifference to, science in general, more especially on the part of our governing classes. This war, with all its material waste and mental anguish, may bring at least some compensation if it finally rouses us from complacency and teaches us to utilise more fully the highly trained and specialised intelligence of the nation.

### *The Geological Survey.*

In any discussion of the present outlook of economic geology in Britain we naturally turn first to the work of the Geological Survey. When in 1835 the National Survey was founded with De la Beche as its first Director, it was clearly realised by the promoters that its great function was to develop the mineral resources of the Kingdom, which involved the systematic mapping of the rocks, and the collection, classification, and study of the minerals, rocks, and fossils illustrative of British Geology. For upwards of eighty years this work, launched by the enthusiasm and far-sighted genius of De la Beche, has been nobly sustained. We geologists outside the Survey are ever willing to testify to the excellence, within the Treasury-prescribed limits, of the published maps and memoirs. Indeed, it would be difficult to name a Government service in which the officers as a body are more efficient or more enthusiastic in their work.

We have ceased to hear rumours of Treasury misgivings as to whether the Geological Survey can justify, on financial grounds, its continued existence. When we call to mind the untold wealth of information and fact in the published maps, sections, and memoirs, the enormous value of such knowledge to mining, civil engineering, agriculture, and education, and indirectly to the development of the mineral resources of the whole Empire, and then reflect that the total annual cost of the Geological Survey of England, Wales, Scotland, and Ireland is somewhere near 20,000*l.*—less, that is to say, than the salary and fees we have been accustomed to pay every year to a single Law Officer of the Crown—we should find it difficult to bear patiently with any narrow or short-sighted official view.

But the time is opportune, I think, when we may ask whether the Survey is fulfilling all the functions that should be expected of it; whether it is adequately supported and financed by the Government; whether it should not be encouraged to develop along lines which, hitherto, from sheer poverty of official support, have been found impracticable.

It will be admitted that the re-mapping of the coalfields, which were originally surveyed on the old 1-inch Ordnance Maps more than half a century ago, before much of the mining information now available could be utilised, is a primary duty and a pressing public necessity. But it would be a great mistake to allow other areas which have apparently little or no mineral wealth, and are destitute, so far as we at present know, of any geological problem of outstanding interest, like the problem of the Highland Schists, to remain, as at present, practically unsurveyed. Take, for example, the great spread of Old Red Sandstone in South Wales and the Border counties of England, which on the present Government maps is indicated with a single wash of colour, and here and there an outcrop of cornstone. It is true that the southern fringe of this area has been recently surveyed in more detail in re-mapping the South Wales Coalfield; but there remain upwards of 2,000 square miles of Old Red Sandstone unsurveyed. A map indicating merely the outcrop of the main bands of sandstone, conglomerate, marl and limestone would be of great assistance to engineers in such works as water-supply and sewage, as well as to agriculture. I am aware that many other areas more clamorously demanding a survey could be cited; but I give this example because it happens that a few months ago the Survey Maps of the area were found to be useless for the

purposes of an engineering work which had necessarily to be based upon the local geology.

It is sometimes said, and with truth, that the great function of a Survey is to produce a geological map which should be a 'graphic inventory,' so far as its scale permits, of the mineral resources, actual and potential, of a country. After all, such a map, even when accompanied with its horizontal section and used by the trained geologist, is a very imperfect instrument by which to summarise and accurately to interpret the results of the surveyor's work. There is so much to express that a single map will not always suffice. It may be desirable to show not only the outcrops of the strata at the present surface, but the thickness of the beds, and even the shape of a buried landscape or sea-plain surface, now unconformably overlaid by newer rocks. That the Geological Survey are alive to the importance of such work is shown by some of their recent publications. The memoir on the 'Thicknesses of Strata in the Counties of England and Wales, exclusive of rocks older than the Permian,' published this year, is a most valuable compilation, bringing together officially for the first time a vast amount of useful fact, mainly from open sections and borings. May we not look forward to the time when the Survey can issue maps with 'isodiametric lines' showing the thicknesses in the case of important beds; for example, sheets of productive coal measures, water-bearing beds, and so forth? In any case, we may confidently expect maps that will show by contours the shape and depth of those buried rock-surfaces, whether unconformities or otherwise, which limit strata of peculiar economic value. The Director of the Survey has already given us a foretaste in his valuable and suggestive maps of the Palæozoic platform of South-East England,<sup>1</sup> and in the contoured maps of the base of the Keuper and of the Permian to the east of the Yorkshire, Nottingham, and Derby Coalfield, and the rock-surface below sea-level in Lincolnshire.<sup>2</sup>

Some of the new edition one-inch colour-printed maps, excellent though they are, suffer by being overburdened with detail already, and we ought to consider whether it is not possible to issue maps of selected districts in series, as is done in the beautifully printed atlases of the United States Geological Survey, where each map of the series shows one particular set of features.

As regards the Descriptive Memoirs which accompany the new maps, the matter is often so compressed that it is little more than a record of bare fact. No one desires the prolixity and the repetition that mar many of the publications of the United States Survey, but we can surely afford a reasonable space for proper description, illustration, and argument; nor, seeing that the memoirs are permanent records of high scientific value, is it desirable to have them cheaply printed on poor paper. It is said that some Treasury 'Minute' lays it down that the cost of production of a Government publication must be covered by the anticipated sales of the same; and to comply with this 'Minute' the public has to pay upwards of 1*l.* for a single geological sheet, because it happens to include a little detailed geology which adds somewhat to the cost of colouring up. Why not demand that the person living on an island off the West Coast of Scotland shall pay, say, 3*s.* 6*d.* for every letter he receives by post, that being, approximately, what it costs the State to deliver it?

We have yet to realise that technical knowledge, of the highest value to the country and obtained at great cost and labour, should be distributed as widely as possible, and at the lowest or even at a nominal charge. I would go further, and put much of the technical information in a simple and attractive form. We might even hope, for example, to eradicate the lingering superstition of the water divining-rod, which is still requisitioned by some public bodies. How admirably clear, simple, and direct is the information on water-supply in the little Survey Memoir entitled 'Notes on Sources of Temporary Water Supply in the South of England and Neighbouring Part of the Continent,' price 2*d.*, evidently produced under the stress of war conditions, and all the better for it.

<sup>1</sup> A. Strahan, Pres. Address to Geol. Soc. 1913.

<sup>2</sup> *Mem. Geol. Surv.* 'Thicknesses of Strata,' pp. 88 and 110.

During the last few months a series of much more important publications by the Geological Survey has appeared. I refer to the Special Reports on the Mineral Resources of Great Britain, of which some six volumes are completed. The Survey is to be congratulated upon starting a line of investigation and report which is a return to some of its oldest and best traditions. The Preface, by the Director, to the first volume of the series, that on the 'Tungsten and Manganese Ores,' is illuminating and symptomatic, for it reveals a consciousness of our shortcomings in the past and points the way to reform in the future.

He says: 'The effects of the war, in increasing the demand for certain minerals of economic value, have led to many inquiries as to the resources in Britain of some materials for the supply of which dependence has been placed upon imports, and have raised the question whether further exploitation and improvements in method of preparation of those minerals would now be justified.'

Valuable mineral deposits in old workings, the delimitation of still unworked ground, old waste-products now of great value under changed conditions of demand, are vital matters dealt with in these volumes. In a pregnant passage the Director says: 'It has become apparent also that some of our home products would be at least equal to material we have been importing, provided that they could receive equally careful preparation for the market, and that with improved treatment and greater facilities for transport, they would be fit to compete with some of the foreign materials.'

In the volume on 'Barytes and Witherite' it is stated that 'apart from the very highest qualities, there is no scarcity of barytes in Great Britain, but that notwithstanding that fact more than half the amount used in this country has been imported, and that 34 per cent. of the amount used came from Germany.' Owing to fineness of grinding and low freights, the imports of this mineral from Germany have increased at a bigger rate than our own output, a state of things that surely will never recur.

At a meeting of the Organising Committee of this Section in February last, the following recommendation was sent to the Council of the British Association:—

'In view of the numerous important instances which have been brought to its notice of the exploitation in alien interests of minerals in the British Empire, the Council of the British Association for the Advancement of Science realises the national importance of preparing for publication special reports on the mineral resources of Great Britain, and recommends the extension of the inquiry to the whole of the British Empire. The Council expresses a hope that it may be possible to expedite this work by utilising the services of persons with expert or special local knowledge. For this purpose an addition to the annual vote for the Geological Survey would be required.'

It is gratifying to learn that the Council has forwarded this Recommendation, with others, to the proper Government authorities, and we may hope that adequate facilities will be given to continue and extend this most valuable work.

#### *The Geological Survey and the Imperial Institute.*

The terms of the Recommendation I have just read remind us that an institution under State control, and supported by Government funds, has already attempted some such work as is here contemplated. I refer to the Imperial Institute at South Kensington. From the Scientific and Technical Research Department reports and papers appear from time to time on the mineral resources of Britain and the Colonies. Thus, 'The Occurrence and Utilisation of Tungsten Ores' appeared in 1909, and similar reports on the ores of chromium, titanium, zinc, &c., and on the coal and iron resources of the British Crown Colonies and Protectorates have been published. These reports are all unsigned, although presumably written by competent persons. Such investigations, although primarily dealing with the Colonies, necessarily overlap to some extent similar work undertaken by the Geological Survey in this country. The point, however, I wish to make is that the work, both for Britain and the Crown Colonies and Protectorates in so far as it relates to prospecting, mapping, and reporting on mineral resources, could be done more

effectively by the staff of the Geological Survey. There is no need to duplicate such a staff in the Government service. Men of the standing of our Government surveyors, specially trained on the economic side, who are at present investigating our home mineral resources, are admirably fitted to do similar work in the Crown Colonies. As for the self-governing Dominions and India, they have their own Geological Surveys and may be relied upon to develop their own mineral wealth.

We are told in the Bulletin of the Imperial Institute<sup>3</sup> that 'Mineral surveys, under the supervision of the Director of the Imperial Institute, and conducted by surveyors selected by him, are in progress in several countries'—Ceylon, Northern Nigeria, Southern Nigeria, Nyasaland—and reports thereon are published from time to time. Should not such Surveys be undertaken by the highly trained staff and the tried organisation of the Geological Survey?

So far as I am aware, there is not even an official connection between the Imperial Institute and the Geological Survey; and it is to be regretted that in the recent Act of Parliament whereby the management of the Institute is definitely transferred to the Colonial Office, and which provides for the appointment of an Executive Council of twenty-two members to supersede the present Advisory Committee, no provision is made for the co-operation of the Geological Survey in the geological and mineralogical side of the Institute's work. And may I say, in passing, that I think it is also a grievous mistake to develop a Research Department at the Institute without making some attempt to collaborate with the neighbouring Imperial College of Science and Technology, which, with its fine equipment and expert staff of researchers and teachers, should constitute a real Imperial College of Science and Research, in fact as in name?

But, these matters apart, it will be recognised on all hands that an ample field remains open for the energy and enterprise of the Imperial Institute as a great central Clearing House of scientific and technological knowledge for the whole Empire, and especially for bringing the results of scientific investigation into touch with the main streams of industry and commerce. For my own part, I believe that the Imperial Institute, without trespassing upon the legitimate duties and functions of the Geological Survey, could and ought to perform most of the functions which Sir Robert Hadfield recently referred to<sup>4</sup> when he suggested the creation of a new 'Central Imperial Bureau.'

#### *The Development of Concealed Coalfields.*

I pass on to consider what is, or should be, another phase of the work of our National Survey, namely, the discovery and development of concealed coalfields.

The Royal Coal Commissions of 1866 and 1901, and frequent addresses and reports by leading geologists in recent years upon the extension of our coalfields under newer rocks, bear witness to the sovereign importance of this branch of economic geology. One after the other the coalfields are being re-mapped by the Geological Survey, and we confidently expect the work to continue. But as the known coalfields become opened up and gradually exhausted, the question of the survey and development of concealed coalfields becomes ever more pressing and vital to our position as a great industrial nation.

In the Yorkshire, Nottingham, and Derby Coalfield the rapid extension of workings eastward under the Permian and Triassic cover during recent years has been remarkable; and although the estimates of its buried Coal Measures adopted by the Commission of 1901, at that time thought conservative, have since come to be regarded as too liberal, we may still rely upon a buried field of workable coals larger in area than the exposed Coal Measure ground of this great coalfield, so that the whole combined field will prove the richest in our islands.

The Kent Coalfield has made a peculiar appeal to popular imagination,

<sup>3</sup> January-March 1916, p. v.

<sup>4</sup> Inaugural Meeting of the Ferrous Section of the Metallurgical Committee of the Advisory Council for Scientific Research (*Nature*, May 25, 1916).



partly because of its proximity to London, and its distance, amid England's fairest garden, from the great and grimy industrial areas of the North. A recent address by Dr. Strahan vividly describes the rapid exploitation of this field.<sup>5</sup>

A problem of perhaps wider geological interest than that of the Kent Coalfield, and certainly of greater complexity, and containing the possibility of an even richer economic harvest, is the occurrence of buried Coal Measures under the great sheet of red rocks between the Midland coalfields, and under newer beds in the area to the south and east of them, towards London.

For the ultimate solution of this problem an appeal will have to be made to many geological principles of which the high theoretical interest is universally acknowledged, although their practical importance is not so immediately apparent. Thus the minute zonal work in the Chalk, the laborious studies among Jurassic Ammonites, as well as the detailed investigations of minor transgressions and non-sequences in the Mesozoic rocks generally, will all have their value when estimating the nature and thickness of cover over the buried Coal Measures.

But the shape and structure of the buried Palæozoic foundation of East and South-central England, with its possible coal-basins, is a more difficult because a more obscure question. It has already claimed the serious attention of geologists, and will doubtless demand in the near future a more rigid and exhaustive study.

Professor Watts, in his Presidential Address to the Geological Society in 1902, dealt in considerable detail with the possible methods of extending our knowledge of this problem, and Dr. Strahan has returned to the problem again and again in recent years.<sup>6</sup>

One obvious line of attack is the more intensive study of the structure of the exposed coalfields, which is made possible by our ever-widening knowledge obtained largely from coal workings, present and past.

And here I digress for a moment to lay stress upon a great and needless loss of valuable and detailed knowledge of our Coal Measure geology. It is well known that the Home Office Regulations demand that plans of workings in the different seams at a colliery shall be made and maintained by the colliery officials; and that on the abandonment of the mine copies of such plans shall be kept at the Mines Department of the Home Office for future reference. For ten years, however, they are regarded as confidential. Such information is recorded primarily with a view to the prevention of accidents due to inrushes of water and accumulations of gas.

Unfortunately, as mining men can testify, the plans are often woefully incomplete, inaccurate, and positively misleading as regards such features as faults, rolls, wash-outs, and so forth, and this is notoriously so along the margin of the plans where workings have been abandoned. Cases have been brought to my notice where plans of old workings have been consulted when adjacent ground was about to be explored, and subsequently the plans have proved to be grossly inaccurate, with the consequent risk of serious economic waste. I believe this unfortunate state of things is partly the effect of the complete official severance of the Geological Survey and the Mines Department of the Home Office. When the Geological Survey was first established, and for many years afterwards, a Mining Record Office for the collection and registration of all plans relating to mining operations was attached to it; but subsequently the Mining Record Office was transferred to the Home Office.

I would suggest that it ought to be made possible for all mining plans to be periodically inspected by Government officials with geological knowledge, not merely after the plans are deposited in a Government office, but during the working of the mine; so that, if desirable or necessary, the geological facts indicated by the mine-surveyor on the plan can be tested and verified. If accurate and properly attested plans of old workings were always available, the opening up of new ground would be greatly facilitated and much waste of time and money would be avoided.

<sup>5</sup> 'The Search for New Coalfields in England.'—Royal Institution of Great Britain, March 17, 1916.

<sup>6</sup> Presidential Address to Section C, Brit. Assoc., 1904; Presidential Address to Geol. Soc., London, 1913.

*Geological Features of the Visible Coalfields which bear upon the Distribution and Structure of Concealed Coalfields in the South Midlands of England.*

In touching upon this question of possible buried coalfields in the South Midlands of England, I wish briefly to refer to a few points connected with our detailed knowledge of already explored coalfields which must be taken into account. They may be grouped under two heads—

- (1) The stratigraphical breaks which are said to exist within the Coal Measures themselves; and
- (2) The post-Carboniferous and pre-Permian folding, and its relation to pre-Coal-Measure movements.

Geologists who have made a close study of the detailed sequence of any British coalfield are fairly agreed that, while sedimentation was accompanied by a general subsidence, the downward movement was discontinuous, possibly oscillatory, as evidenced, on the one hand, by the occurrence of marine bands in a general estuarine series, and, on the other hand, by those coal seams, particularly, which consist of terrestrial accumulations of plant-material. But on a critical analysis of prevalent views we meet with considerable difference of opinion as to the inferences to be drawn from the known facts.

Jukes-Browne, referring to Coal Measure time, says 'that it was a period of internal quiescence, a period in which terrestrial disturbances were at a minimum,'<sup>7</sup> and this notwithstanding his advocacy of the tremendous plication of the Malvern and Abberley Hills in the middle of the Coal Measure period, that is, in the interval between the Middle and Upper Coal Measures of England. Another high authority says 'The Coal Measure Period as a whole was one of crust movement.'<sup>8</sup>

Dr. Gibson, after a detailed survey of the North Staffordshire Coalfield, where the Middle and Upper Coal Measures are fully and typically developed, asserts that 'no break has been detected in the Coal Measure sequence';<sup>9</sup> and a like conclusion is to be drawn from the work of the Government surveyors and from borings in the Yorkshire, Derby, and Nottingham Coalfield and that of East Warwickshire.

Mr. Henry Kay<sup>10</sup> would fix a local unconformity at the base of the Halesowen Sandstone of South Staffordshire, and another at the base of the Keele Beds (or so-called Lower Permian Marls); while in the Coalbrookdale Coalfield the well-known Symon Fault, described by Marcus Scott as a great erosion-channel in the Middle or Productive Measures, subsequently filled up by the unproductive Upper Coal Measures,<sup>11</sup> was interpreted by W. J. Clarke in 1901<sup>12</sup> as a pronounced unconformity, a view which has been generally accepted ever since, and which was eagerly seized upon by those who hold that the Malvernian disturbance occurred at this time.

The interrelation of the divisions of the Coal Measures is, in view of the search for hidden coalfields, so important that I wish to pause for a moment to consider the significance of the evidence for this unconformity which is said to exist in the Midlands between the Middle and Upper Coal Measures.

The plate which illustrates Marcus Scott's paper on the Symon Fault<sup>13</sup> shows the upper beds plotted out from the lowest workable seam in the older measures, which he assumes to be horizontal (their original position); while Clarke, using Scott's data, plots his sections from the base of the Upper Measures, which he uses as a horizontal datum-line.<sup>14</sup> Incidentally I may remark that in both cases the sections are drawn with a much-exaggerated vertical scale, and, of course, correspondingly exaggerated dips.

In my opinion, both these interpretations are misleading (apart from the question of scale), because in neither case is the adoption of the horizontal datum-

<sup>7</sup> *The Building of the British Isles*, 1911, p. 169.

<sup>8</sup> *Q.J.G.S.*, 1901, vol. lvii., p. 94.

<sup>9</sup> *Q.J.G.S.* 1901, vol. lvii., p. 264.

<sup>10</sup> *Q.J.G.S.* 1913, vol. lxix., pp. 433-453.

<sup>11</sup> *Q.J.G.S.* 1861, vol. xvii., pp. 457-467.

<sup>12</sup> *Q.J.G.S.* 1901, vol. lvii., pp. 86-95.

<sup>13</sup> *Ibid.*

<sup>14</sup> *Ibid.*

line strictly justified by the facts. In the one case the curvature of the basin is made too great, and, in the other, the dips in the Middle Measures are unduly increased; for, as mining plans show, the base of the Upper Measures is by no means horizontal. The fact is that the undulations in the measures throughout the coalfield are extremely slight, there being scarcely any perceptible dip in the strata, as noted by Scott, except near what is called the 'Limestone Fault,' where the dips, as will presently appear, can be otherwise accounted for. Furthermore, there is a significant absence of faults other than those which affect Middle and Upper Measures equally.

I believe there is another and a simpler explanation of this classic disturbance, and one which harmonises, in part, the views of both Scott and Clarke; and at the same time helps to give us a reasonable interpretation of the apparently conflicting statements which have been made by working geologists respecting the relationship of the Coal Measure divisions in the Midlands.

The Keuper Marls of the Midlands occur either in horizontal or very gently undulating sheets, but Dr. Bosworth has shown that around Charnwood Forest they dip in all directions, 'sometimes to the extent of 20 or even 30 degrees,' and that everywhere the inclination is in the direction of the rock-slope beneath, though always at a smaller angle than the slope. This local dip (or 'tip,' as he calls it) 'seems most likely to have been largely caused by contraction of the marls under pressure and by loss of moisture.'<sup>15</sup>

In a paper dealing with the Coal Measures of the Sheffield district published this year,<sup>16</sup> Professor Fearnside directs attention to a research by Sorby, embodied in a memorable contribution to the Geological Society of London in 1908<sup>17</sup> upon the contraction of clay sediment due to loss of water. It appears to me that the penetrating genius of Sorby, with that clarity of vision which comes from patient and exact quantitative experiment, may help us to clear up some of the difficulties to which I have referred. If the Coal Measure clays have lost something like five-sixths of the original thickness they possessed as mud or slime, as Sorby's quantitative experiments seem to indicate, is it not possible that the discordance we are discussing between the Middle and Upper Coal Measures is due, in part at all events, to differential contraction and consequent local sagging during the extremely slow squeezing out of the water by the pressure of overlying sediment? We must remember that the Middle Coal Measures consist essentially of clays, and that over a large part of the Midlands they were deposited on a very uneven floor, and that to start with they were therefore of very variable thickness. It is easy to see, also, that an arenaceous fringe of sediment where the measures abut against a rise in the floor would suffer far less vertical contraction from this cause than the clay, because of the very diminished 'surface energy' of the constituent sand particles, and that this would have the effect of accentuating the dip due to the sag.

It is to be noted that Scott's observations and the bulk of his section referred to the central parts of the coalfield, while Clarke deals primarily with the district just north of Madeley and along the south-eastern fringe of the 'Limestone Fault,' which may prove to be, in my opinion, in its early stage at all events, a pre-Coal Measure ridge of limestone.

It is quite possible, indeed probable, that portions of the undulating surface of the Middle Coal Measures suffered local erosion, which, however, need not imply folding of the beds with prolonged subaerial denudation; for it seems likely that such local erosion was subaqueous, producing a non-sequence similar in character (and origin perhaps) to the relatively small stratigraphical breaks which have been recognised recently in the Jurassic strata in the West of England and elsewhere.

Thus, in North Staffordshire, where the Midland Coal Basin is deepest, no break between the Upper and Middle Measures exists; but approaching the southern margin of the basin, to the south of the South Staffordshire Coalfield, where the Middle Coal Measures are rapidly thinning, there are, if Mr. Kay's observations are correct, signs of a non-sequence or local unconformity. The

<sup>15</sup> *The Keuper Marls around Charnwood, 1904-1911*, pp. 47-50.

<sup>16</sup> *Trans. Inst. Min. Eng.*, vol. 1., Part 3, 1916.

<sup>17</sup> *Q.J.G.S.* 1908, vol. lxiv., pp. 171 *et seq.*

same is true, but on a larger scale, in the Symon Fault of the Coalbrookdale Coalfield,<sup>18</sup> and is to be explained, if the above reasons are valid, by the rapid variation in thickness of the Middle Measures, due to the irregular floor upon which they rest, to the consequent sagging of the beds, and also to local sub-aqueous erosion. Further, such partial unconformities or non-sequences would generally indicate the proximity of that marginal fringe where the Upper Measures overlap the Middle, and rest on pre-Coal Measure strata.

The Middle and Upper Coal Measures of the Midlands record general but intermittent subsidence, with a considerable pause at the end of Middle Coal Measure time, followed by a much more general depression, as shown by the extended and overlapping sheet of Upper Coal Measures. But there is no evidence which I regard as convincing that regional elevation or great orogenic movements occurred until after the Upper Coal Measures were laid down.

The floor upon which the Middle Coal Measures were deposited along the southern fringe of the Midland Coalfields was a sinking and already folded and denuded floor, and it is to be expected, therefore, that these measures rest in submerged gulfs and estuaries, which would mean that some, at any rate, of the several coal basins were originally isolated wholly or in part, and their separation is not to be interpreted as due to folding and subsequent denudation.

Dr. Newell Arber has argued that the Middle Coal Measures of Coalbrookdale, the Forest of Wyre, and the Clee Hills were deposited in three separate basins, which as regards the Sweet Coal or Productive Measures were never continuous.<sup>19</sup> On the other hand, just as it is certain that the Productive Measures on either side of the South Pennines were originally continuous, so it is probable that as we go northward from this southern fringe the Productive Measures spread out into more extensive sheets.

Before leaving the subject I should like to make it clear that I do not wish dogmatically to assert that the conditions were exactly as I have just outlined. We want many more careful observations before the case can be proved. But I do submit that the facts so far as known are capable of the interpretation I have put upon them; and that such an interpretation is more consonant with the results obtained by workers among the Coal Measures of the Midlands generally than that which has been in vogue since Clarke's paper on the Symon Fault was published.

The folding and faulting impressed upon the measures after their deposition, as determining the position and structure of exposed and concealed coalfields alike, are obviously of prime importance; but involved in these movements are those of pre-Coal Measure time. So complex and confused are these combined disturbances that our main hope of grasping their salient features and of applying the knowledge to further the development of new mineral ground is to study more closely the tectonics of our already-worked coalfields and their immediate borders.

As an example of such intensive geological work, I should like to refer to the detailed plotting by Mr. Wickham King of the Thick Coal of South Staffordshire on the 6-inch maps. For more than twenty years he has been engaged in collecting and tabulating an immense number of levels and other data from colliery officials, and from old and sometimes half-forgotten borings; and he has now produced a contoured map and a model to the same scale, showing in great detail the folds and faults in the Thick Coal. In 1894 Professor Lapworth, to whose initiative this work was due, emphasised the value of such 'plexographic maps' of coal seams, and predicted that such maps would be drawn in all the coalfields.<sup>20</sup> The data obtained in South Staffordshire also enable us to determine, at some places exactly, at others approximately, the shape of the pre-Coal Measure floor and the outcrops of its constituent formations; and to disentangle, in part, the pre- and post-Coal Measure movements. Thus we get

<sup>18</sup> Mr. Wedd has recently described a similar break between the Middle and Upper Coal Measures of the northern part of the Flint Coalfield. (See Summary of Progress of Geol. Surv. for 1912, pp. 14, 15.)

<sup>19</sup> *Phil. Trans. Roy. Soc., London*, Series B, vol. cciv., pp. 431-437. 'On the Fossil Floras of the Wyre Forest, &c.'

<sup>20</sup> *Fed. Inst. Min. Eng.*, vol. viii., 1894-5, p. 357.

additional evidence to show that before Middle Coal Measure time, denuded folds, with a north-west or Charnian trend, and other folds with a north-east or Caledonian trend prevailed. The post-Carboniferous and pre-Permian movements emphasised and enlarged some of these folds. As already remarked, a matter of great practical importance is as to how far these pre-Coal Measure folds interfered with the continuity of deposition of the productive series, with, for example, the original extension of the Thick Coal of South Staffordshire. Since Jukes' time it has been known that the Thick Coal group as a whole thins, and the coal itself deteriorates, southward towards the Clent and Lickey Hills. It is the discontinuity and local deterioration in an *east* and *west* direction, beyond the Boundary Faults, due to pre-Coal Measure flexures, and irrespective of post-Carboniferous movement, that I have been emphasising.

The powerful disturbances of post-Carboniferous and pre-Permian age, which have affected all our coalfields, I have no intention of discussing here. Professor Stainier, the Belgian geologist, has just published a lengthy and able discussion of the subject,<sup>21</sup> while the lucid account by Dr. Strahan in his Presidential Address in 1904 and his recently summarised views in a lecture to the Royal Institution will be in the minds of all geologists.

I do not think, however, that it is generally realised what a great part the two dominant pre-Carboniferous systems of folding played in determining the trend of the post-Carboniferous flexures. In the South Pennines, in the Apedale disturbance of North Staffordshire and in the Malverns we have nearly north and south folds due to a great easterly thrust; but elsewhere in the Midlands and the North the movements were taken up, to the west of these north and south lines by the Caledonian folds, and to the east by the Charnian flexures. It is very instructive to watch in the centre of the South Staffordshire Coalfield the old Charnian fold of Silurian rocks that make up Dudley Castle Hill, the Wren's Nest and Sedgley Hill struggling, as it were, against the newer post-Carboniferous easterly squeeze, which has impressed a north and south strike upon each of the domes, arranging them *en échelon* from north-west to south-east, and incidentally permitting the great laccolitic intrusion of Rowley Regis.

It will be found, however, that the vast majority of the folds and faults in the Midland and Northern Coalfields are not along what may be called strict Hercynian lines—that is, north to south and east to west—but along the locally older Caledonian and Charnian directions. It was as if the great north and south flexures of the Southern Pennines and Malverns, and the east and west Armorican folds of the South of England, to a large extent exhausted the mighty attack of the Hercynian movements coming from the South and East of Europe; while smaller intervening and relatively sheltered areas were allowed to yield along their old north-west and north-east lines.

#### *Need for Systematic Survey by Deep Borings.*

After all, when we turn our attention to the possible extension of the Coal Measures under the newer strata of South-Central England, the geological data at our disposal are lamentably and surprisingly few. Notwithstanding our eagerness to unravel the difficulties, and so to open up new fields for mining activity, very little positive progress has been made in the last twenty years. Of late a few deep borings have been sunk; one near High Wycombe, after piercing the Mesozoic cover, ended in Ludlow rocks; another at Batsford in Gloucestershire, fifteen miles north of the well-known Burford boring, struck what are regarded as Upper Coal Measures, also resting on Silurian rocks.

At the present time it seems specially fitting to call attention once again to our haphazard method of grappling with this great economic question. Are we to go on indefinitely pursuing what is almost 'wild-cat' boring, to use the petroleum miner's expressive slang? Or shall we boldly face the fact that systematic exploration is demanded; and that this pioneer work is a national obligation, the expense of which should be a national charge?

At the meeting of the Organising Committee of Section C, already referred to, a recommendation was forwarded to the Council in the following terms:—

<sup>21</sup> *Trans. Inst. Min. Eng.*, vol. li., Part I., 1916, pp. 99-153.

'The Council of the British Association for the Advancement of Science recommends that the site, depth, and diameter of every borehole in the British Isles, exceeding 500 feet in depth, be compulsorily notified and registered in a Government Office. That all such boreholes be open to Government inspection during their progress. That copies of the journals and other information relating to the strata penetrated by the boring be filed in a Government Office under the same restrictions as those relating to plans of abandoned mines.'

I would go further and urge that the Government should undertake the sinking of deep borings at selected points. This is no new idea. In his Presidential Address to the Geological Society of London in 1912 Professor Watts pleaded most forcibly the vital importance of a State-aided underground survey of the area to which I have referred. The work is too vast for individual effort, or even for a private company to undertake. It is not suggested that deep borings should be sunk with the express purpose of finding coal. What is wanted is a systematic survey by borings at such spots as are likely to throw light upon the structural framework of the Palæozoic floor and the thickness of its cover.

Of course, there are difficulties in the way of such a scheme. There is the expense. But in view of the enormous economic possibilities of the work, and remembering that it is now possible to sink a boring to a depth of, say, 1,200 feet, and to bring up 18-inch cores at a cost of less than 2,000*l.*, it cannot be reasonably argued that the expense is beyond the nation's power to bear. A levy of a farthing a ton on the coal output of the United Kingdom for a single year would yield something like 300,000*l.*, a capital sum that would provide in perpetuity an additional yearly grant to the Geological Survey of 15,000*l.*, which would suffice not only to carry on this work, but would enable the Survey to extend its functions in the other directions I have indicated.

As to legal obstacles and vested mineral rights I wish to say nothing, except that if the country could be convinced that this work is urgently needed on national grounds, all scruples and doubts, so agitating to the official mind, would speedily vanish.

For many years I lived near our great exporting centres of the finest steam coal in the world; and as I watched the steady and incessant streams of coal-waggons, year in, year out, coming down from the hills, I was constantly reminded that we are rapidly draining the country of its industrial life-blood. Is it an extravagant demand to ask that an infinitesimal fraction of this irreplaceable Nature-made wealth should be set aside to provide the means for the discovery and development in our islands of new mineral fields?

#### *Chemical and Microscopical Investigation of Coal Seams.*

The recovery of bye-products in the coking of coal, which up to the beginning of the War was almost exclusively undertaken by the Germans, is likely in the future to become an important British industry. This will ultimately demand a thorough knowledge of the microscopic and chemical structure of all the important coking seams in our coalfields.

Remembering how varied both in microscopical structure and chemical composition the individual laminæ of many of the thick coal-seams are, it will readily appear how important such a detailed investigation may become, having regard to the great variety of these bye-products and their industrial application. Moreover, thin seams, hitherto discarded, may pay to be worked, as may also an enormous amount of small coal, estimated at from 10 to 20 per cent. of the total output, which up to the present has been wasted.

#### *Geology of Petroleum.*

It has been frequently remarked that in order to account for the vast accumulation of coal in the Carboniferous strata, it is necessary to postulate a special coincidence over great areas of the Northern Hemisphere of favourable conditions of plant growth, climate, sedimentation, and crustal subsidence; conditions which, although they obtained at other geological periods over relatively small areas, were never repeated on so vast a scale. Having regard to the estimates of coal deposits in Cretaceous and Tertiary strata, published in our

first International Coal Census, the 'Report on the Coal Resources of the World,'<sup>22</sup> it would appear that we might reasonably link the Cretaceo-Tertiary Period with the Carboniferous in respect of these peculiar and widely prevalent coal-making conditions. For I find that of the actual and probable reserves of coal in the world, according to our present state of knowledge, about 4½ million million tons of bituminous and anthracite coal exist, the vast bulk of which is of Carboniferous age; while there are about 3 million million tons of lignites and sub-bituminous coals, mostly of Cretaceous and Tertiary age.

When we look to the geological distribution of *Petroleum*, we note that it is to be found in rocks of practically every age in more or less quantity, but that it occurs *par excellence*, and on a great commercial scale, in rocks of two geological periods (to a smaller extent in a third); and it is significant that these two periods are the great coal-making periods in geological history—the Carboniferous and the Cretaceo-Tertiary. It would take me beyond my present purpose to explore the avenues of thought and speculation opened up by this parallel. I will only remark that it seems to afford some support for the view that coal and petroleum are genetically as well as chemically related. While the terrestrial vegetation of the two periods was accumulating under specially favourable physiographical conditions ultimately to be mineralised into seams of coal, the stores of petroleum believed to be indigenous to strata of the same periods were probably derived from the natural distillation of the plankton which must have flourished, too, on an enormous scale in the shallow, muddy waters adjacent to this luxuriant land growth. The phytoplankton, including such families as the Diatomaceæ and Peridinæ, may well have played the chief rôle in this petroleum formation, while affording unlimited sustenance to the small and lowly animal organisms, like Entomostraca, whose fatty distillates doubtless contributed to the stores of oil. It is possible, then, that a prodigious development of a new and vigorous flora during both periods—the spore-bearing flora, in the main, of the Carboniferous, and the seed-bearing flora of the Cretaceo-Tertiary period—was the chief contributory factor in the making of the world's vast store of solid and liquid fuel. It contributed directly by supplying the vegetable matter for the coal, and indirectly by stimulating the development of a prolific plankton, from which the oil has been distilled.

The world's production of petroleum has trebled itself within the last fifteen years. In 1914 the United States of America produced 66·36 per cent., and North and South America together nearly three-fourths of the world's total yield; while the British Empire (including Egypt) produced only a little more than 2 per cent. In the near future Canada is likely to take its place as a great oil- and gas-producing country, for large areas in the middle-west show promising indications of a greatly increased yield. But Mexico is undoubtedly the country of greatest potential output. Its Cretaceous and Tertiary strata along the Gulf Coastal Plain are so rich that it has been stated recently on high authority that 'a dozen wells in Mexico, if opened to their full capacity, could almost double the daily output of the world.'<sup>23</sup>

As is well known, natural supplies of petroleum are not found in the British Isles on a commercial scale; but for many years oil and other valuable products have been obtained from the destructive distillation of the Oil Shales of the Lothians. If Mr. Cunningham Craig is right in his views recently expressed,<sup>24</sup> these shales, or rather, their associated freestones, have been nearer to being true petroliferous rocks than we thought; for he believes that the small yellow bodies, the so-called 'spores' in the kerogen shales, are really small masses of inspissated petroleum, absorbed from the porous and once petroliferous sandstones with which the shales are interstratified.

If recent experiments on peat fulfil the promise they undoubtedly show, we shall have to take careful stock of the peat-bogs in these islands. It is well

<sup>22</sup> Report on 'The Coal Resources of the World' for the Twelfth Intern. Geol. Congress, 1913.

<sup>23</sup> Ralph Arnold, 'Conservation of the Oil and Gas Resources of the Americas,' *Econ. Geol.*, vol. xi., No. 3, 1916, p. 222.

<sup>24</sup> Institution of Petroleum Technologists, April 1916.

known that peat fuel has been manufactured in Europe for many years. But my attention has been called to a process for the extraction of fuel-oil from peat, which has been tried experimentally in London, and is now about to be launched on a commercial scale, utilising our own peat deposits, like those of Lanarkshire and Yorkshire.

The peat is submitted to low-temperature distillation at ordinary pressure, or at a slight negative pressure, the highest temperature reached being about 600° C. From a ton of Lanarkshire peat, after the moisture is reduced to 25 per cent., 40 gallons of crude oil, 18 to 20 lbs. of ammonium sulphate, about the same quantity of paraffin wax, 30 to 33 per cent. of coke, and 5,000 to 6,000 cubic feet of combustible gas are obtained. The coke is said to be of very good quality. By the same process it is hoped to get satisfactory results from the lignites of Bovey Tracey.

Considering the rapid development of oil as fuel, and its supreme industrial importance in many other ways, it is remarkable that British geologists should have given such little attention to the *origin and occurrence of petroleum*. Among American geologists a lively interest in this subject has been aroused and a voluminous technical literature is already published. And yet the fact remains that we are still in a cloud of uncertainty as to this vital question, upon the solution of which depends whether the prospector of the future is to work by hazard or on scientific and reasoned lines.

Mr. Murray Stuart, now of the Indian Geological Survey, offered in 1910<sup>25</sup> a simple explanation of the occurrence of petroleum, based upon his own observations in Burma, a research which seems to have attracted far more attention in America than in this country. He showed that the oil of the streams and swamps in Burma is carried down to the bottom of the water in small globules by adhering tiny particles of mud. Thus there is formed a deposit of mud containing globules of oil and saturated with water. If subsequently this deposit is covered by a bed of sand, the oil and part of the water, as the pressure of overlying sediment increases, are squeezed into the sand, so that by a repetition of the process a petroliferous series of clays and sands may be accumulated. In examining lately a large quantity of the well-known 'landscape marble' from the Rhætic of Bristol, I obtained from it small but appreciable amounts of petroleum; and towards the end of my investigation I was pleased to discover that I was in thorough agreement as to the origin of this curious landscape structure with Mr. Beeby Thompson, whose research was published more than twenty years ago.<sup>26</sup> In these thin deposits of hydrocarbons among laminated silts, with their striking tree-like growths and hummocky surfaces, may we not have, in miniature, an illustration of the deposition and partial migration of petroleum which occurs on so vast a scale in the oilfields of the world?

It is not suggested that all petroleum deposits have had such an origin. I am convinced, however, that in all geological ages such sedimentary accumulations have occurred; and that, except where the conditions of cover have been favourable for its imprisonment, the oil is, and has been throughout geological time, incessantly escaping at the surface. Thus we may conceive the earth as continuously sweating out these stores of oil, either in the liquid or gaseous form, especially where rocks are being folded and rapidly denuded.

It is sometimes asked whether the adoption of mineral oil as a power-producer is likely to supplant coal, and thereby seriously reduce the output of that mineral. The world's yield of petroleum will doubtless go on increasing at a very great rate; but from the experience gained in some of the fields in the United States and Eastern Canada, it seems unlikely that this increase can continue for a very long period. Practically complete exhaustion of the world's supply is to be looked for within 100 years, says one authority.<sup>27</sup> Even if the output rose to ten times the present yield, it would represent only about half the present world output of coal, and it is practically certain that so high a yield of

<sup>25</sup> *Rec. Geol. Surv. India*, vol. xl., 1910, pp. 320-333: 'The Sedimentary Deposition of Oil.'

<sup>26</sup> *Q.J.G.S.* 1894, pp. 393-410.

<sup>27</sup> H. S. Jevons, *British Coal Trade*, 1915, p. 710.



oil could not be maintained for many years. Owing to the almost certain rapid increase in the output of coal, estimates made by the authority already quoted indicate that the total production of petroleum could never reduce the world's output of coal by more than about  $6\frac{1}{2}$  per cent.<sup>28</sup>

For us, and probably for those of the next generation, the geology of petroleum will continue to be of immense practical importance; but coal will doubtless remain our great ultimate source of power.

An obligation rests upon us to see that the oil resources of the British Empire and of territories within our influence are explored, if possible, by British geologists, with all the specialised knowledge that can be brought to bear; and I am glad to think that the University of Birmingham and the Imperial College of Science and Technology, London, with this end in view, are doing pioneer work in giving a systematic and specialised training to our young petroleum technologists.

#### *Underground Water.*

It is pleasant to recall that this Section of the British Association has in the past done yeoman service in stimulating investigation and in collecting valuable data which have a direct practical and economic application. As far back as 1874 a Committee of Inquiry was 'appointed for the purpose of investigating the Circulation of Underground Waters in the Permeable Formations of England and Wales, and the quantity and character of the water supplied to various Towns and Districts from these Formations.' For many years this Committee compiled records of borings, which might otherwise have been lost, and some of the local Scientific Societies affiliated to this Association did similar work in their respective districts.

Since the year 1856, when the Frenchman, Darcy, attempted by a mathematical formula to express the law governing the transmission of water through a porous medium, nearly all investigation upon this important engineering question has been carried on in the United States; and many of the results have been published in the valuable Water Supply and Irrigation Papers of the United States Geological Survey. Particular reference should be made to the work of Hazen, King, Darton, and Slichter, the last of whom has given us the clearest and most convincing explanation of the behaviour of water percolating through a porous rock. He and his co-workers have experimentally investigated the factors which determine the underground flow, and expressed their relationship by mathematical formulæ; and they have made it clear, by careful measurement extended over long periods, that the rate of flow through average porous water-bearing rocks and under ordinary pressure gradients is extremely small, something like a mile a year, or even less.<sup>29</sup>

Geologists who are in touch with the application of these principles to such engineering matters as water-supply, sewage, and drainage will readily appreciate the great value of such researches. At the same time, one must reluctantly confess that, with few exceptions, these investigations have not been adequately grasped and utilised in present-day engineering practice in this country. As to their geological bearing, we have only to be reminded of the important processes of solution, cementation, and fossilisation in rocks in order to comprehend the value of a just estimate of the behaviour of this vast and slow-moving chemical medium in which the superficial rocks of the crust are immersed.

A wide and fertile field of research has been opened up to the mining geologist by the recognition of the important rôle played by ground-water in ore-genesis and in the 'secondary enrichment' of ores. In this country, however, the circulation of underground water, and especially the relation of rainfall and 'run-off,' concern the civil engineer more than the miner. There exist, unfortunately, much confusion and uncertainty in engineering practice in regard to such geological questions; and this is due partly to a want of precision in the use of terms, though mainly to a lack of reliable data. One finds, for example, frequent discrepancies in statistics of rainfall in relation to percolation and

<sup>28</sup> H. S. Jevons, *British Coal Trade*, 1915, p. 716.

<sup>29</sup> Water Supply Paper, No. 67, *U.S. Geol. Sur.*: 'The Motions of Underground Waters.'—Slichter.

'run-off,' because the term 'run-off' is used in two senses—either to express the total river-discharge in a catchment area, when it would obviously include practically all percolation within such area; or to express the local surface run-off, which could be utilised for reservoir-storage in the area in question, as distinct from the fraction of the rainfall which percolates into the ground and subsequently emerges at lower levels.

Another source of error arises from a disregard of the fact that the percolating water in any area may be regarded as a storage-reservoir which tends to equalise the surface stream-flow during periods of varying rainfall; and that in pumping operations on a large scale the natural equilibrium becomes disturbed, not only water of percolation but also part of the surface run-off in the form of springs, seepages, and streams being drawn upon.

The conditions are so complex and the controlling factors vary so much in different river-basins that it is impossible to obtain for the whole country anything like an accurate and reliable expression for the relationship between rainfall, percolation, and run-off. The interminable and costly legal wrangles during the passage of a Water Bill through Parliament bear witness to the truth of this statement. What is needed is a continuous record in the different catchment areas of the country of observations on river discharge, percolation, and so forth, extended over many years. Fortunately, our rainfall observations, thanks to the British Rainfall Organisation, are now, or could be made, ample for this purpose. But except for attempts by local water companies and corporations to obtain the data I have referred to, there exists no public control to deal with the matter.

In 1906 a Committee of the Royal Geographical Society, with Dr. Strahan as Chairman, and with the aid of a grant from the Royal Society, undertook to investigate river discharge, suspended and dissolved matter, rainfall, area, and geological conditions in some specially selected river-basins. The final report, which has now appeared, dealing with the Severn above Worcester, the Exe, and the Medway, constitutes a most valuable record.

The mean discharge of the Severn above Worcester from 1882 to 1889 comes out as 46.2 per cent. of the rainfall, and for the Exe 55.9 per cent. The Severn may be taken as an average river for these purposes, and we note that the discharge is distinctly higher than what we should expect from figures usually given in text-books.

It will be obvious to all geologists that important theoretical questions, such as the rate of denudation and deposition, and vital engineering matters, such as the position and permanency of harbour works, would be greatly assisted by exact quantitative estimates of the material carried down by rivers.

In 1878 Joseph Lucas urged the importance of a Hydro-geological Survey of England, and the Royal Commission on Canals and Waterways in their final report in 1909 recommended the appointment of some public authority to do for the whole country what this Committee has so admirably done for these three river-basins.

#### *Organisation of Expert Knowledge.*

We are reminded by the report of a later Royal Commission—that on Coast Erosion in 1911—that systematic observations and the collation and organisation of geological and engineering knowledge are urgently needed in connection with the protection of our coasts and the reclamation of new lands. For it will be remembered that the Commission found that during the last thirty-five years the gain of land, as shown by Ordnance Survey maps, has been more than seven times the loss by erosion.

Here, again, the British Association may reflect with pride that it paved the way for this national inquiry. For many years its Committee on Coast Erosion gathered and collated evidence on erosion, and induced the Admiralty to instruct the Coastguard to observe and report upon changes that take place from time to time.

After recommending 'that the Board of Trade should be constituted the Central Sea-Defence Authority for the United Kingdom for the purpose of the administration of the coast-line in the interest of sea defence,' the Commissioners go on to urge that 'that Department should have the assistance of scientific experts to collate information and to secure systematic observations

with regard to questions such as the changes taking place below the level of low water, the travel of materials in deep water, the movements of outlying sand-banks, etc., which are continually happening on the coasts of the Kingdom, and with regard to which the information at present is scanty and vague.<sup>30</sup>

Is it not abundantly clear that in economic geology, as in the case of other applied sciences, we must rely in the future less upon chance individual effort and initiative? We must concentrate, centralise, and organise; and at every stage we shall need expert control and advice as regards those larger scientific issues of national importance which have a direct practical bearing.

The following Papers and Report were received :—

1. *The Local Geology.* By Professor G. A. LEBOUR, F.G.S.

2. *Some Notes on the Permian of Durham.*

By Dr. D. WOOLACOTT, F.G.S.

See 'Stratigraphy and Tectonics of the Permian of Durham, Northern Area,' *Proc. of the Univ. of Durham Phil. Soc.*, vol. iv. pt. 5, 1911-12; and 'Geology of N.E. Durham and S.E. Northumberland,' *Proc. of Geologists' Assoc.*, May 1912.

3. *A Plexographic Model of the Thick Coal of South Staffordshire.*

By W. WICKHAM KING, F.G.S.

[PLATE IV.]

Mr. E. B. Marten, C.E., of Stourbridge, between 1865 and 1893 collected over 400 levels of the thick coal of South Staffordshire and located them on maps. At Professor Lapworth's suggestion, Mr. Marten and the author in 1893-4 endeavoured to make a map showing the contours in the thick coal, based upon these levels, but the information was insufficient.

Subsequently, with the kind help of many persons, the author increased these levels to 1,798 and constructed therefrom a map on 6-inch scale depicting the contours of the thick coal. The model exhibited (see plate) is made from this map and is to the horizontal scale of 6 inches to the mile, while the vertical scale is enlarged  $1\frac{1}{2}$ . The object of the work is to throw light on the tectonics of the adjacent concealed coalfields by ascertaining the detailed structure of the visible coalfield.

The 2,500 feet declivity to Hampstead is well shown. One photograph will not bring out that there is a corresponding declivity of from 1,200-2,500 feet from the Himley-Sedgley arête to Baggeridge.

In this preliminary account of the model, the general structure may be summarised thus :

- (1) A Central (Rowley) ridge, with a general Charnian trend (N.N.W.-S.S.E.) about 12 miles long, running through Blackheath to Sedgley.
- (2) Two minor ridges, sub-parallel to the central ridge: the first from Great Barr to Essington ( $6\frac{1}{2}$  miles), N.E. of which the thick coal splits up into several seams; the second from Hagley, near Stourbridge, to Kingswinford (6 miles).

The intervening troughs are :—

- (a) The wide Oldbury-Tipton basin E.N.E. of the central ridge.
- (b) The narrower Cradley-Pensnett syncline W.S.W. of the central ridge.
- (c) The still narrower and deeper Stourbridge-Kingswinford trough W.S.W. of its corresponding ridge.

<sup>30</sup> Royal Commission on Coast Erosion, etc., 1911. Third (and Final) Report, pp. 160-161.

The central or Rowley ridge is sagged at three equidistant (4 miles) places, (a) near Halesowen, (b) S.S.E. of Dudley, and (c) N.N.W. of Sedgley, and at these places it is crossed by three Caledonian trend-lines with a general S.S.W.-N.N.E. direction. The middle one of these trend-lines connects up the anticlinal arête of Netherton, the synclinal ravine of Tividale, and the Walsall plateau, each of these elements being four miles long. The north-western consists of the Himley to Sedgley Park arête (4 miles), beyond which it sinks into a shallow syncline (3 miles), and rises again, near to and beyond Essington, into a narrow arête. The south-eastern one forms an arête, not shown on the model, from near Hagley in the direction of Halesowen, which sinks into a long and broad synclinal ravine towards and far beyond Halesowen (5 miles), and then becomes a well-developed anticlinal arête from Spon Lane to beyond Great Barr. The Central Caledonian trend-line therefore divides the two synclines on the opposite sides of the central Charnian ridge, each into two parts, that to the W.S.W. being divided by a sharp anticlinal arête, and that to the E.N.E. by a narrow and deep synclinal ravine.

The Central Charnian and Caledonian trend-lines form an X.

The evidence, derived from over fifty pits sunk into, and the outcrops of, the Pre-Carboniferous rocks, shows that movement in both Charnian and Caledonian directions, accompanied by and followed by faulting and denudation, had taken place in the district previous to middle coal-measure time, and that this denudation was greatest at the S.S.E. ends of the Charnian anticlines, and less on the Caledonian anticlines.

The Central Charnian ridge, from Sedgley to south of Blackheath, combined with the east to west faults of the Tipton and Cradley synclines, closely approach to the form of the letter S. The throw of the most important of these faults is in the Tipton syncline to the south,<sup>1</sup> and in the Cradley syncline to the north. They invariably die out to the east in both these synclines, against the S.S.E. ends at Blackheath and Walsall, of the more denuded parts of the Charnian ridges, whilst they succeed to the west, with greatly diminished throws, in breaking through and laterally shifting the N.N.W. end of the Charnian and the S.S.W. end of the Caledonian ridges at Sedgley and Lye, which had been elevated much less by these two older movements.

The Central Caledonian trend-line, comprising, as the middle limb, the anticlinal arête of Netherton and the synclinal ravine of Tividale, if combined with the Langley N.-S. and the Stourbridge-Kingswinford S.S.E.-N.N.W. arêtes also forms the letter S.

The plexography of South Staffordshire is markedly reflected in the plexography.

A plexographic map of the South Wales syncline made by some person who could collect information therefor, before the Cardiff meeting, should materially increase our knowledge.

---

#### 4. *Underground Contours of the Black Mine.* By Dr. G. HICKLING.

---

#### 5. *Underground Contours of the Barnsley Thick Coal.* By Professor W. G. FEARNSIDES.

---

*Joint Meeting with Section K.*—See p. 493.

---

<sup>1</sup> Compare Jukes' Memoir, 2nd ed., p. 165.

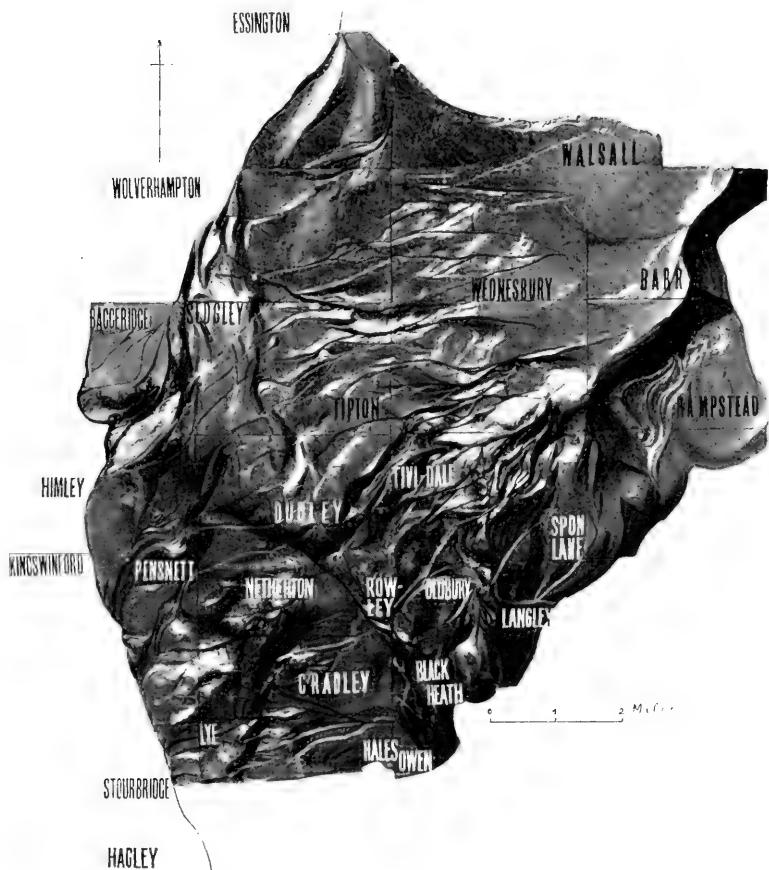

*Illustrating Mr. W. Wickham King's Paper 'A Plexographic Model of the Thick Coal of South Staffordshire.'*



THURSDAY, SEPTEMBER 7.

Joint Meeting with Section B.

*Discussion on the Investigation of the Chemical and Geological Characters of different varieties of Coal, with a view to their most effective utilisation as fuel, and to the extraction of bye-products.*

Professor G. A. LEBOUR, in opening the discussion, dealt with the various aspects from which coal may be studied, and showed that, while certain of these fall within the province of the geologist alone, any satisfactory classification of the various types of coal, and the elucidation of the varying characters of seams as traced from place to place, can be achieved only by the close co-operation of geologists and chemists.

Professor W. A. BONE briefly summarised the limited knowledge so far attained regarding the chemical constitution of coal, pointing out that the great bulk of the analyses hitherto made were directed merely to estimation of the fuel value of samples. In his opinion no great progress was likely to be made except on the lines of some well-considered scheme of research in which the various workers would find their place and collaborate.

Professor KENDALL addressed himself particularly to the question of the nature and origin of the ash in coal-seams. He recognised three sources of the mineral matter: (1) the residue of the mineral constituents of the plants; (2) detrital mineral matter; (3) the calcite, iron-pyrites, &c., segregated as veins in the seams. It was shown that the different modes in which these several types of ash are distributed in the coal are of great economic consequence, some being separable, others inseparable. The bearing of ash on the mode of origin of the coal was also discussed.

Dr. DUNN gave some account of the highly variable chemical nature of the ash of coals. He dwelt on the necessity for the analysis of coal-samples specially selected with a view to their suitability as bearing on the geological history of the deposit, for the purpose of arriving at a philosophical theory of coals and their classification. The work and expenditure involved would be such that the matter could only be dealt with on a national basis.

Professor BEDSON drew attention to the reports of a Committee of Section B, published in the Transactions of the Association in 1894 and in 1896, dealing with the action of various solvents on coal. Though some further progress had been made on these lines we were still lacking exact information as to the natures of the substances dissolved and of the undissolved portions.

Mr. D. TREVOR JONES and Dr. R. V. WHEELER presented a report on the chemical constitution of coal. The coal conglomerate may be resolved into cellulosic and resinic portions, the former containing molecules with the furan structure and yielding phenols on distillation. The resinic derivatives contain compounds in which alkyl, naphthene, and unsaturated hydroaromatic radicles are attached to larger and more complex groupings. Under the influence of pressure the bulk of the resinic derivatives have become highly polymerised. The oxygenated resinic derivatives are chiefly oxides, probably cyclic oxides; esters, lactones, anhydrides, acids and ketones are absent or present only in small quantity. Hydrocarbons exist in the resinic portions of coal; saturated hydrocarbons (paraffins) are, however, present in small quantities only. The temperature to which coals have been subjected must have fallen short of 300° C.

Dr. MARIE C. STOPES dealt with the palæobotany of coal in relation to chemical constitution. It was well known that sufficiently thin sections of coal showed themselves under the microscope to have been formed from a variety of plant tissues, and on the analogy of living plants it was therefore to be presumed that a corresponding variety of chemical substances contributed to the formation of the coal. Living vegetable tissues could by no means be simply

divided into 'cellulosic' and 'resinic' types. Each constituent tissue might be supposed to have given rise to characteristic decomposition-products in the coal; and, in conjunction with Dr. R. V. Wheeler, she was now engaged in testing this point. Such tissues as spore-walls and cuticles proved insoluble in pyridine, and could thus be separated and separately analysed. It was hoped to track down the characteristic products of other tissues in a similar way. Co-operation between the chemist and palaeobotanist was clearly essential.

Dr. HICKLING desired to support all that Dr. Stopes had said regarding the importance of microscopic study as a guide in the interpretation of the chemistry and geology of coal. He wished only to question the necessity of any very close connection between the chemical constitution of the vegetable 'tissues' now distinguishable in coal and that of the original tissue of the living plant. It seemed probable that very extensive substitution of material might have occurred, and that the present character of the coal might be dependent more largely on the extent and character of the 'decomposition' processes than on the original composition of the tissues involved.

Professor FEARNSIDES dealt with coal as a rock-genus, within which a number of essentially different species have already been recognised, and asked that chemists should express these specific differences in terms of chemical constitution. He suggested that the methods of etching used by metallographers might be applied to the study of polished surfaces or cleat surfaces of coal. It was to be desired that the same blocks of coal analysed by the chemist should be studied by the palaeobotanist, and that the geologist and mine-worker should combine in choosing samples worthy of investigation. In particular, co-operation between chemists and geologists was to be desired to secure a knowledge of the lateral variations in composition within the individual lenticles of coal which in sum constitute the coal-seam.

Professor BOYD DAWKINS wished to emphasise the probability that the original substance of the plant-tissues whose remains are seen in coal may have been largely replaced by other materials. He quoted examples of such replacement in fossils of all types, showing that replacement is the rule and not the exception. Some indication of the organic form of the fossil may even be imparted to the mineral matter which may be deposited around or within it. In his opinion, the greater part, if not the whole, of the organic element in the coal had been subjected to mineral change.

Professor W. S. BOULTON (who presided) expressed his gratification at the opportunity for an interchange of ideas among chemists and geologists upon a subject of vital importance to the nation. Already much valuable research upon the nature and composition of coal had been done, both on the analytical and on the microscopical and palaeobotanical side. He felt sure that when the printed records of the discussion were published they would serve to stimulate fresh and more vigorous research, and more especially to co-ordinate and mutually assist the work of the chemist and geologist, and so enormously increase the value of our greatest industrial asset.

---

The following Papers were then read:—

1. *A Method of indicating the Age of Geological Formations on Maps in Black and White.* By Dr. J. W. EVANS.

All Pre-Cambrian rocks are represented by shading having a N.W. and S.E. trend; the older Palaeozoic by shading with a N.E. and S.W. trend; the younger Palaeozoic by N. and S. shading, and the Mesozoic by E. and W. shading. The earlier metamorphic Pre-Cambrian is indicated by continuous lines, the later metamorphic by broken lines having the intervals in adjoining lines alternating with each other; and the unmetamorphosed Pre-Cambrian by those having the intervals opposite. The Cambrian, Ordovician, and Silurian (older Palaeozoic) are distinguished in a similar manner, and so are the



Devonian Carboniferous and Permian (younger Palæozoic); and the Trias, Jurassic, and Cretaceous. The Kainozoic (Tertiary) is indicated by small crosses, diagonal for the Eocene and Oligocene, and upright for the Miocene and Pliocene. In each case the earlier division is distinguished by the crosses in adjoining rows (following the direction of the arms) alternating, and the later by crosses opposite each other in such adjoining rows. The Anthropozoic (Quaternary) is shown by rows of small circles or dots, the former being reserved for the Pleistocene and the latter for the Recent.

Minor divisions may be distinguished (1) by varying the size, thickness, or spacing of the lines or other symbols, (2) by adding new symbols. Where desirable, the recognised symbols of lithological characters may be added to those denoting the formation. Passage Beds between two formations may be shown by a combination of shading.

For volcanic rocks the symbols employed for sedimentary rocks are very much thickened. When the age of intrusive rocks is known, it may be indicated by the corresponding shading for sedimentary rock, with the white and black interchanged; or, if preferred, their nature may be shown by white letters on black.

## 2. *The Acid Rocks of Iceland.* By LEONARD HAWKES, M.Sc.

An account was given of the preliminary results of an investigation of the Tertiary acid series. It is known that these rocks are widely developed in East Iceland, but hitherto definite information as to their extent, nature, and mode of occurrence has been lacking. Whilst they have been stated to be partly intrusive and partly extrusive (I., p. 269), it has generally been accepted that they are dominantly intrusive in character (I., p. 232; II., p. 5; III., p. 783), a view which has probably been influenced by the general intrusive nature of the British Tertiary acid rocks (IV., p. 364).

The main exposures of acid rocks in East Iceland from Borgarfjord to Berufjord have been studied in the field. Evidence was brought forward to show that these rocks are in the main extrusive in character. In places (*e.g.* the Borgarfjord district) the acid series is at least 2,000 feet in thickness. Tuffs and spherulitic liparites and obsidians are very common. The author holds that the old view that the acid rocks are dominantly intrusive, being thus marked off from the basic rocks, is incorrect. Tertiary volcanic activity was similar to that which has obtained in Iceland in post-glacial times, when acid rocks have been extruded along with the basic, but in a smaller amount. Acid eruptions seem to have taken place almost continuously during the building-up of the Tertiary plateau. The uneroded character of the liparite lava streams shows how rapidly the successive basalts which submerge them were poured out, and this throws some light on the problem of the intrusive or extrusive origin of the Antrim rhyolites.

Since the close of the Tertiary volcanic period enormous denudation has obtained, and the varying resistance offered to erosive agents by acid and basic rocks has produced some remarkable effects.

Thoroddsen (I., p. 159) has described some peculiar streams of acid rocks which he regards as post-glacial lava flows, formed by the extrusion of liparite blocks in a half-melted condition from the mountain-sides. The most noteworthy of these occurs in the Lodmundarfjord. The rocks of the district are Tertiary bedded basalts, with the exception of an acid series, contemporaneous with the basalts, revealed in a huge cirque excavation in a side valley. The valley is full of a chaotic assemblage largely composed of spherulitic liparite reaching down from the cirque (Skúmhöttur) on to the bottom of the main (Lodmundarfjord) valley. The author holds that these blocks do not represent a lava-stream but a moraine. All the rocks of the stream occur *in situ* in the Skúmhöttur mountain. The theory of morainic origin has been previously rejected partly on account of the reported exclusive liparite composition where a mixture of acid and basic rocks would be expected. It was found, however, that the stream is not exclusively composed of acid types, though dominantly so. The large proportion of liparite present results from its lesser resistance to ice-erosion compared with basalt, whereby the huge cirque has been excavated

where the acid rocks occur, and the material deposited to form the present remarkable stream. It has also been objected that none of the blocks are ice-scratched, but this is not to be expected owing to the exceptional fissility of liparite and its rapid degradation under weathering influences—the author has never seen an ice-scratched boulder in Iceland.

I. TH. THORODDSEN. 'Island: Grundriss der Geographie und Geologie.' No. 152. Pet. Mitt. 1905.

II. H. PJETURSS. 'Island: Handbuch der Regionalen Geologie.' 1910.

III. C. W. SCHMIDT. 'Der Liparite Islands in geologischer und petrographischer Beziehung.' 'Zeitschrift der Deut. geol. Gesell.' Vol. xxxvii. 1885.

IV. Sir A. GEIKIE. 'Ancient Volcanoes of Great Britain.' Vol. ii. 1897.

### 3. *The Petrology of the Arran Pitchstones.* By ALEXANDER SCOTT, M.A., D.Sc.

Although the Arran pitchstones are so widely known, no extensive examination of them has ever been made. The intrusions, which number about eighty, may be divided into the following groups:—

- (a) Non-porphyrific glasses with abundant microlites which are generally hornblende. These are chiefly found in the district round the coast and include the Corriegills and Monamore Glen occurrences.
- (b) Pitchstone-porphyrifics with large phenocrysts of quartz and felspar and scarce augite and with hornblende microlites. This group includes many of the dyke-rocks intrusive into the Goatfell granite.
- (c) Pitchstone-porphyrifics with phenocrysts of felspar and pyroxene and subordinate quartz. The pyroxene includes both augite and enstatite, and scarce crystals of an iron-rich olivine are also found. Microlites of pyroxene and of hornblende occur. This group is typical of the intrusions of the south end of the island.
- (d) More basic type with scarce phenocrysts and great abundance of pyroxene microlites. This group is represented by two occurrences in Glen Cloy and several around the great Tertiary volcanic vent.

Analyses have been made of each type, and the results show the existence of considerable variation in composition.

An attempt has been made to determine the cooling histories from the examination of the field relations and the microscopic structures of the various types, and also to indicate the conditions which are responsible for such a large development of glassy intrusive rocks.

---

FRIDAY, SEPTEMBER 8.

#### *Joint Meeting with Section E.*

The following Paper was read:—

#### *The Physical Geography and Geology of the Northern Pennines.* By Dr. A. WILMORE.

This paper attempts a brief summary of the structure of the Northern Pennines for geologists and geographers, especially for those who are interested in the relation of geographical form to geological structure. It is, for the most part, a re-statement, and advances little that is new; but it is thought that the present visit of the Association to the North may be a fitting opportunity to summarise our knowledge of the structure of an interesting region, especially as considerable progress has been made in our detailed knowledge of the Northern Pennines since the visit of the Association to Newcastle in 1889.

By 'The Northern Pennines' as treated in this paper, we mean that well-

defined part between the two great gaps—the Tyne Gap and the Craven or Aire Gap. In this part of the Pennines the mountain masses are broader and higher, and the structure is somewhat different from that of the Pennines south of the Craven Gap. The familiar anticline is not so conspicuously developed as in the southern half of the Pennines.

In the Northern Pennines the student may see very clearly indeed the broad dependence of the topography upon rock-character, rock-position, and geological history.

The Craven or Aire Gap may be taken as a convenient starting-point. This is a lowland region of roughly triangular form drained by four local river systems: the Wharfe, the Aire with Broughton Beck, the Ribble with the Lancashire Calder, and the Wenning (one of the feeders of the Lune). Each of these outlets of the 'gap' is utilised by a railway. The Leeds and Liverpool Canal follows the valleys of the Lancashire Calder and the Aire, and crosses the Pennines at an elevation of a little over 500 feet (the highest point is at Foul-bridge Tunnel, near Colne).

The Middle Pennine Gap is determined by the great Craven Fault system and the folding of the strata to the South and South-West of the fault. The general direction of the folding is from W.S.W. to E.N.E. Near the Fault there is considerable and somewhat intense local folding, and probably some repetition of the beds.

North of the Craven Gap—and stretching to the Tyne Gap—is the Plateau or Block-country—the Northern Pennines of this paper—determined mainly by the three great western fault systems; these are the Pennine, the Dent, and the Craven Faults. Three 'blocks' of the Northern Pennines are thus formed: (1) the Cross Fell block, (2) the Mallerstang or Dent block, (3) the Ingleborough-Penygent block. On these plateau-blocks the mountains stand, excellent examples of mountains of circumscription or residual mountains. Ingleborough or Penygent may be taken as a type of these mountain masses, standing on the plateau-floor of the Great Scar Limestone and capped by outliers of Millstone Grit. The Great Scar Limestone is gradually replaced towards the north by the coming in of the Bernician type. The Great Scar Limestone of the Penygent block is a region famous for pot-holes and underground streams, such pot-holes as Gaping Ghyll and Alum Pot being well known. On the great plateau numerous streams disappear to reissue in the valleys below, frequently at the unconformity where the limestone, with or without its basement conglomerate, lies almost horizontally on the upturned edges of the Older Palæozoic rocks.

These plateau-blocks are not all similarly related to the adjacent westerly regions. On the east of the great Pennine Fault is the wedge-shaped Vale of Eden, filled with Permian and Triassic strata. There is an interesting inlier chiefly of Older Palæozoic rocks occurring between the Carboniferous plateau-block and the New Red beds of the plain. This is known as the Cross Fell inlier, and is characterised by a series of magnificent 'pikes,' like a narrow strip of the Lake Country tacked on to the western edge of the Pennines. This inlier stretches from near Brough in the south to Melmerby in the north. The *Dent Fault* has its downthrow to the east, and along the complex fault-line the Carboniferous Limestone is in contact with the Older Palæozoic rocks of the Howgill Fells and the moors to the north and north-east of Kirkby Lonsdale. The Carboniferous block to the east of this fault is the Mallerstang block of this paper. It is remarkable for the great number of mountain masses which rise to between 2,000 and 2,400 feet. An eastern part of this block is the original region of the Yoredale of Professor Phillips (Wensleydale is Yoredale or Uredale). The Craven Fault system throws the Carboniferous Limestone, chiefly the Great Scar Limestone, against Permian, or Coal-measures, or Millstone Grit, or the higher divisions of the Carboniferous Limestone itself.

To the geographer the change of scenery in crossing these faults is most interesting. The view from the western limestone scars of the Cross Fell block across the Vale of Eden to the Lake District mountains is one of the finest in Britain. The change from the Older Palæozoic Howgill Fells, Grayrigg Fells, Middleton and Barbon Fells eastward across Garsdale or Dentdale to the Carboniferous Fells of the Yoredale country of Mallerstang is, perhaps, not so

striking but is yet very marked. The change from the Penygent block—with its great plateau floor, its step-like Yoredale mountains, capped with grits, and its steep-sided gorges—to the rolling country of Bowland and the Craven Lowlands provides one of the best geographical contrasts in the North of England.

To the geologist there are many interesting problems, in which considerable progress has been made in the last quarter of a century, but many points in which are still obscure. Some of these are: the change in the type of stratification from the Pendleside type and Bowland type at the southern end of the region through the Yoredale type to the Bernician of the north, and the satisfactory correlation of the different facies; the relation of the now famous 'knoll' limestones, best seen immediately south of the Craven Fault, to the Lower and Upper Carboniferous Limestones of more normal type, and the whole problem of knoll-structure; the sharp folding immediately in front of the faults. Dr. Marr has pointed out the knoll-like structure produced in the Keisley Limestone of the Cross-Fell inlier, and has compared it with the limestone of Draughton Quarry to the south of the Craven Fault. There are many folded greyish-white limestones in the knolls of Craven which are very much like those of Keisley; the Carboniferous Limestone floor and the different times of its submergence, on which new light has been thrown by Prof. Garwood's recent work. An interesting paper on this subject was presented by Dr. Vaughan last year—his last paper; the relation of the pre-Pennines—a part of the old Caledonian system, the rocks of which seem to have had cleavage developed in them during the early Devonian folding, and which suffered denudation in later Devonian and early Carboniferous times; the immense thickening of the Millstone Grit to the south, and the precise relation of its rock-material to the denudation of the Caledonian Alps; and the age of the various foldings and faultings which have determined (in the main) the present Pennines.

All these problems have their geographical aspect. The old Palæozoic floor in Ribblesdale and the bit of wild scenery of another type—an inlier in the Carboniferous of the Penygent plateau; the striking rounded and ovoid form of the Craven knolls; the apparently great thickness of grit of the Bowland Fells, and especially of the Pendle Range—these and many similar phenomena interest alike the geologist and the student of Physical Geography.

The age of the faults and folds has been discussed by several distinguished workers. There was, of course, the pre-Pennine folding in Devonian times; faulting was possibly in progress in Carboniferous times as taught by Mr. Tiddeman; great earth-movements occurred at the end of the Carboniferous period; Professor Kendall has shown that there was upward movement of the Pennines in early Permian times, between the deposition of the Lower Brockram and the Upper Brockram; the great faults, especially the Pennine and Craven Faults, and the earlier folding were probably Permo-Triassic and possibly in part post-Triassic (the Craven Fault is, in the main, later than the Dent Fault, as it cuts the latter sharply at the southern end near Kirkby Lonsdale); the great continent- and mountain-building movements of mid-Tertiary time probably gave (according to Dr. Marr) the final broad form to the Northern Pennines, and determined the *general* consequent drainage system of the region.

Dr. Marr, Professor Kendall, Professor Fearnside, and others have dealt with some of the interesting and important Glacial and post-Glacial changes of drainage of which there are many examples in the Northern Pennines. These Pleistocene changes may be studied especially well in the Howgill Fells, the Bowland Fells, and the Craven Lowland country.

---

The following Papers and Reports were then received in Section C. :—

1. *Note on the Occurrence of Refractory Sands and Associated Materials occurring in Hollows in the Surface of the Mountain Limestone District of Derbyshire and Staffordshire.* By Professor W. G. FEARNSIDES and Dr. P. G. H. BOSWELL.

2. *Some Geological Characters of Sands used in Glass Manufacture.*

By P. G. H. BOSWELL, D.Sc., F.G.S.

At a time when it is necessary to know the extent and value of our national resources of sands suitable for various industrial purposes, including glass-manufacture, it is especially desirable that we should realise the particular properties of such sands and the geological conditions under which the deposits occur in the field.

(a) In chemical composition, for all general purposes of glass-making, the sand should contain a very high proportion of silica ( $\text{SiO}_2$ ), if possible, over 99 per cent. The percentage of iron (estimated as  $\text{Fe}_2\text{O}_3$ ) should be as low as possible. For optical glass, table-ware ('crystal'), &c., it should not rise above 0.05 per cent.; for laboratory-ware, globes, and all second-grade glass-ware, a percentage up to 0.08 is permissible; for plate- and window-glass and good white bottle-glass the proportion may reach 0.1 or 0.2 per cent.; and for rough bottle-glass and other similar work a limit of 2 per cent. may be admitted. For refractory glass, such as that used for thermometers, gauges, certain laboratory-ware, &c., it is an advantage to find a sand bearing 4 per cent. or more alumina. Unfortunately, most British sands bearing alumina carry also iron and other undesirable impurities. Other bases, such as lime, magnesia, titanium, and alkalis, should, if present at all, exist only in negligible quantities. In the analyses the loss on ignition should also appear; it yields an indication of the amount of water and organic substances present. The latter are not objectionable as they usually 'burn out.'

The analysis of one of the best British glass-sands, a sample of Lower Greensand from Aylesbury, indicates:  $\text{SiO}_2$ , 99.80 per cent.;  $\text{Al}_2\text{O}_3$ , 0.32 per cent.;  $\text{Fe}_2\text{O}_3$ , 0.03 per cent.; loss on ignition, 0.22 per cent.; total, 100.37 per cent. With this may be compared a well-known German glass-sand from Lippe:  $\text{SiO}_2$ , 99.88 per cent.;  $\text{Al}_2\text{O}_3$ , 0.18 per cent.;  $\text{Fe}_2\text{O}_3$ , 0.02 per cent.; loss on ignition, 0.21 per cent.; total, 100.29 per cent.

(b) For all but the highest-quality glass, where the cost of crushing the raw material to a fine even state, with suitable subsequent treatment, is not prohibitive, the mechanical composition is of the utmost importance. The sand used should, if possible, be perfectly graded: that is, it should be composed of grains all of the same size. Such perfection of grading is not attained as a result of natural agencies; the best-graded natural deposits contain over 90 per cent. of grains of one grade, which, for glass-making purposes, is preferably the medium-sand grade (diameter  $> \frac{1}{4}$  and  $< \frac{1}{2}$  mm.). A high percentage of the fine-sand grade (diameter  $> \frac{1}{4}$  and  $< \frac{1}{10}$  mm.) would be even more preferable, but suitable sands with a high proportion of this grade are not of common occurrence in this country. Coarser sand-grains are not desirable, and, if present, should be removed by sieving. Very fine sand, silt, and clay-grades are inimical, and must be removed by washing. As examples of well-graded glass-sands may be mentioned:—Dutch sand,  $> \frac{1}{2}$  and  $< 1$  mm. diameter, 0.4 per cent.;  $> \frac{1}{4}$  and  $< \frac{1}{2}$ , 94.4 per cent.;  $> \frac{1}{10}$  and  $< \frac{1}{4}$ , 5.1 per cent.;  $> \frac{1}{100}$  and  $< \frac{1}{10}$ , 0.1 per cent.;  $< \frac{1}{100}$  mm., 0.0 per cent.; total sand-grade,  $> \frac{1}{10}$  mm. diameter, 99.9 per cent. King's Lynn (Lower Greensand),  $> \frac{1}{2}$  and  $< 1$  mm., 0.0 per cent.;  $> \frac{1}{4}$  and  $< \frac{1}{2}$ , 94.8 per cent.;  $> \frac{1}{10}$  and  $< \frac{1}{4}$ , 4.9 per cent.;  $> \frac{1}{100}$  and  $< \frac{1}{10}$ , 0.2 per cent.;  $< \frac{1}{100}$  mm., 0.1 per cent.; total sand-grade,  $> \frac{1}{10}$  mm. diameter, 99.7 per cent.

(c) The mineral composition should be as simple as possible. Briefly put, the sand should as far as possible contain only quartz, or quartz and felspar, and the heavy detrital minerals present should be small in quantity and simple in composition.

The treatment of sands (whether chemical, to remove iron, or mechanical, to ensure good grading) often involves prohibitive expense. It is therefore of considerable importance, as well as of some interest, to look into the geological conditions under which desirable glass-sands occur. We may thus receive clues to the existence of further supplies by knowing the kind of deposits in which they are met, and the special conditions under which we may expect to find them. The important supplies of glass-sands occurring in Western Europe are associated with organic matter of planty origin. In support of this statement we may enumerate: Lippe sand, associated with rafts of braunkohle, in beds

of Miocene age; Hohenbocka sand, of the same age, containing carbonaceous layers; Fontainebleau sand, in Upper Oligocene deposits, with lignites; Inferior Oolite sands in the Yorkshire and Northampton districts, containing planty matter and roots; Burythorpe sand (Callovian), containing carbonised woody material and peaty matter; Aylesbury and Leighton Buzzard sands (Lower Greensand) with peaty bands; Headon Hill and Bagshot sands from Alum Bay, Wareham, and other places (Eocene, &c.), interbedded with lignites. Numerous other examples may be adduced. Attention may also be drawn to the very pure sandstones of the Coal Measures, associated with coal-seams, and to the white sandstones found with the Brora coals of Scotland (Callovian). The bleaching of the reddish sands for a foot or two in depth upon our heaths is a similar phenomenon. In each case the freedom from iron may be attributed to the reducing action of the planty matter, in changing the ferric salts to the more soluble ferrous state, when they are more easily removed by percolating waters.

The beds of white sand seem always to be of limited thickness, and frequently to be laid down under lagoon or estuarine conditions favouring the development of plant life.

Cementation is objectionable, either because of the introduction of impurities or because of the cost of subsequent crushing. It is desirable, however, that the deposits should be incoherent. The most widely-used sands are thus of comparatively late geological age. Most of them occur in Tertiary deposits, but some are Cretaceous in age. A strong tendency also exists for the simplification in mineral constitution (due to elimination of more easily decomposable minerals) and greater perfection of grading in the later geological sediments—a result of their constituents having passed through many geological cycles.

---

3. *Report on the Lower Carboniferous Flora at Gullane.*

See Reports, p. 217.

---

4. *Interim Report on the Old Red Sandstone Rocks of Kiltorcan, Ireland.*—See Reports, p. 205.

---

5. *Report of the Geological Photographs Committee.*

See Reports, p. 218.

---

## SECTION D.—ZOOLOGY.

PRESIDENT OF THE SECTION: PROFESSOR E. W. MACBRIDE,  
M.A., D.Sc., F.R.S.

---

WEDNESDAY, SEPTEMBER 6.

The President delivered the following Address:—

THE British Association meets for the third time in the midst of a great European war, which is taxing to their utmost all the resources of the Empire, although we may express the confident hope that these resources will in the future prove themselves as adequate to the strain put on them as they have done in the past. All of us are agreed that our country has entered into this conflict with clean hands, and is striving to attain high and noble aims; but many of us think that the attainment of those aims has been to a considerable extent hindered by a neglect on the part of our rulers and organisers to take advantage of the results obtained by scientific research, and also by their neglect to provide adequate means for the continuance of that research. Hence the Organising Committee of the Section has very wisely sought to encourage the production at this meeting of papers setting forth those results of zoological research which have either a direct economic value as bearing on the rearing of useful animals, or an indirect economic one as teaching us how to combat harmful parasites both of animals and man. But we must never forget that whilst the justification of a science in the long run—at any rate in the eyes of the many—may reside in the value of its applications, yet the first condition of its assured progress is the resolute adherence to the investigation of its underlying laws; and surely of all these laws the most fundamental in the case of biology are the laws of inheritance. These laws, as we are all aware, have been the subject of the most intensive research, especially during the last sixteen years. In these researches, however, the method which has been almost exclusively employed has been that of selective mating between different strains, and attention has been too exclusively focussed on the adult characters of the offspring. Another set of researches which may eventually throw a good deal of light on the laws of inheritance have been going on simultaneously with the experiments on cross-breeding. These researches have had as their object the determination of the laws governing the development of the germ into the adult organism, and researches of this kind are generally denoted by the term *EXPERIMENTAL EMBRYOLOGY*. Even in this time of storm and stress, it seemed to me to be not inappropriate if I were to endeavour in a necessarily brief sketch to take stock of the positive results which have been gained as the harvest of thirty years' work in this branch of zoology.

The founder of the science may be said to be the German anatomist His, who in 1874 published a small volume entitled '*Unsere Körperform und das physiologische Problem ihrer Entstehung*,' in which he defined the scope of the new science and distinguished between what he called the physiological and the phylogenetic interpretations of embryology. He says: 'In the whole series of phases which a developing organism traverses, each previous phase is the necessary preparation for the succeeding one,' and, further, 'The physiological explanation of the forms of the bodies of animals, and the investigation of

their phylogenetic history, are two undertakings whose ways for the present lie in different directions. The more difficult task falls to the lot of the physiological study of form. But if the pursuit of this study demands a concentration of energy and a renunciation of the pleasure of frequent indulgence in wide generalisations, nevertheless it affords the priceless compensation of close contact with the basis of our knowledge of Nature, and to him who follows it with care and perseverance will be granted that sharpness of insight and confidence of judgment which are the characteristics and reward of every exact method.'

His laid down two laws as the basal principles of the new science. The first is the principle of 'SPECIFIC ORGAN-FORMING REGIONS OF THE GERM,' the second is the 'PRINCIPLE OF DIFFERENTIAL GROWTH.' The first principle affirms that the apparently undifferentiated germ is divided into different regions in each of which are situated the materials for the formation of a definite primary organ. It follows that development really consists in the formation of a mosaic of rudiments, each gifted with its own specific rate of growth. The second principle affirms that the rate of growth of these various rudiments are unequal, and that in consequence of the lateral pressures thus set up various types of folding invagination, and other forms of embryogenetic process must result: thus, for instance, His endeavours to explain the separation of the myotomes from the lateral plate in the chick-embryo by the arching up of the dorsal surface which takes place between the second and third days of incubation. Since, according to His, the myotome is attached to the skin, it is pulled upwards along with this and torn away from the lateral plate, which remains below, as this is tied to the yolk.

Indeed, this book, which may be termed the first primer of Experimental Embryology, is largely occupied by showing how secondary displacements of embryonic organs must result from inequalities of growth: its great defect is the absence of experiments to prove that these secondary changes really are the consequences of the primary changes to which His referred them.

To Roux belongs the credit of being the first to make the decisive appeal to experiment. In 1888 he published an account of how he had been able to produce half-embryos of the frog by stabbing and killing one of the first two blastomeres of the developing egg with a red-hot needle. In this way he obtained half-blastulæ and half-gastrulæ, and even older half-embryos, with half a nerve cord and half a notochord. Later he extended his experiments to destroying the anterior two cells or the posterior two cells of the four-cell stage, and claimed in this way to have obtained anterior and posterior half-embryos.

These experiments seemed to supply a solid basis of fact for the first principle of His, viz. that of specific organ-forming areas in the germ; but a most unexpected further discovery by Roux was that of the phenomenon which he termed 'POST-GENERATION.' These half-embryos carried about attached to them the dead blastomere (or blastomeres) which had been destroyed by the experiment. This mass occupied, of course, the position which should have been taken by the missing half of the embryo if the embryo had been a perfect one. Now the half-embryos occasionally survived, and when this occurred the missing half was regenerated, or, as Roux phrased it, POST-GENERATED. According to Roux this took place by the migration of nuclei from the living into the dead half by which the latter was recalled to life, and began to divide into cells which then became moulded into the missing half of the embryo.

Roux's position was strongly attacked by Hertwig, who maintained that Roux had not succeeded in producing any real half-embryos, but that when one blastomere had been killed the other began to develop into a whole embryo; that the processes of folding, invagination, &c., which normally lead to this result were impeded by the presence of the mass of dead yolk, and thus a distorted embryo was produced which Roux had mistaken for a half one. Hertwig pours ridicule on Roux's idea that nuclei could migrate into and revivify a mass of protoplasm killed by being scorched by a red-hot needle, and in subsequent publications Roux receded to the position that the post-generation was due to the production of new cells by the uninjured half of the egg, and that the dead half was only used as food; but he steadfastly



maintained that the embryos which he obtained were real half-embryos and not merely distorted whole ones. Hertwig's position seemed to be upheld by the remarkable experiments of Driesch on the eggs of the sea-urchin. Many of these experiments have become so well known that they have, so to speak, escaped from zoological literature into popular literature, and have even become incorporated in current philosophy. It will therefore be necessary to examine Driesch's work critically, although limits of space forbid us dealing with his experiments in detail, and a very brief description of the more important must suffice.

The first and in many ways the most striking of Driesch's experiments was that of separating the first two blastomeres of the sea-urchin's egg from one another by violent shaking. When this was done he found that each of the separated blastomeres developed into a perfect larva of reduced size. Driesch hailed this as a final proof that the doctrine of 'Specific organ-forming areas' of His which had been endorsed by Roux was fundamentally false. This conclusion he was able to back up by further experiments, especially after his methods had been improved by the discovery made by his friend and co-worker Herbst that when sea-urchin eggs were allowed to develop in artificial sea-water from which lime had been excluded the blastomeres separated from one another spontaneously. Driesch showed that one of the first four blastomeres would develop into a perfect larva, and that in some few cases one of the first eight blastomeres would do likewise.

Driesch asserted that the *fate of a cell was a function of its position in the embryo*, not of its inborn specific quality. He showed that when eggs were allowed to develop under pressure the first eight cells, instead of forming two tiers of four cells each, were spread out in one plane. If the membrane of the egg had been burst these cells did not return to their positions when the pressure was removed, but at the next cleavage formed a double-layered plate of sixteen cells, eight in each layer; and yet this structure would in favourable circumstances develop into a perfectly normal embryo. Now it follows from this that cells which under normal circumstances would have formed the lower pole of the larva must form the sides. To similar conclusions Hertwig was led when he examined the development of frogs' eggs submitted to pressure, either by being sucked into narrow glass tubes or by being pressed between glass plates. He maintained that the dividing planes separating the blastomeres were formed along the lines of pressure, or, in other words, that growth took place at right angles to the pressure: that the *nuclei of the developing egg could be juggled about like a handful of marbles without altering the result.*

Driesch then showed that if the blastula into which the sea-urchin egg develops be cut into pieces, these pieces if not too small will close up and form miniature blastulæ which will develop by the invagination of their lower poles into gastrulæ and further into the well-known pluteus larvæ. Previously to the occurrence of invagination, cells are budded from the lower pole into the cavity of the blastula; these are termed mesenchyme. If the blastula be cut in pieces *after* this has occurred, these pieces may still heal up and form miniature blastulæ; but only blastulæ derived from the lower pole of the original blastula will become converted into gastrulæ and form guts—those derived from the upper pole remain gastrulæ until they die. Another instance of the same thing was observed in the case of the gastrulæ of the star-fish. These are sausage-shaped—not hemispherical, like the gastrulæ of the sea-urchin—and hence comparatively easy to cut across. The gut reaches from the posterior pole only about half-way up. When the gastrula is bisected the stump, including the fragment of the gut attached to the blastopore, will regenerate the missing parts and form a smaller gastrula which will develop into a perfect larva. But if, before bisection has been performed, the apex of the gut has grown out into the thin-walled vesicle from which the cœlom is developed and this is removed by the operation, then, although the stump will heal up and a miniature gastrula will be formed, this gastrula will never form a cœlom.

Driesch talks of **POSITIVE AND NEGATIVE DETERMINATION OF THE POTENCIES** of portions of the growing embryo. To take an instance; when the mesenchyme has been formed in the blastula of the sea-urchin, the lower portion of the

blastular wall is *positively* determined by having conferred on it the power of producing a gut, whilst the upper portion of the blastular wall is *negatively* determined in being deprived of the power of producing a gut: whereas, as we have seen, previous to the formation of mesenchyme either half could produce a gut.

Driesch then began experiments on a totally different kind of eggs, viz. those of the ctenophore *Beroë*. These eggs are much larger than those of the sea-urchin and have an abundant supply of yolk. The first step in development is the division of the egg by longitudinal furrows into a wreath of eight cells. Now it is a comparatively easy matter to separate one or two of these from the rest; and the remainder will then develop into an imperfect ctenophore with seven or six, instead of the customary eight, ciliated ribs. It is therefore evident that the material for one particular rib must be localised in one particular blastomere. Driesch even succeeded in proving that this specialisation existed before the egg had divided into cells at all, for he cut pieces of protoplasm from unfertilised eggs, and those that survived developed into ctenophores with an imperfect number of ribs.

Driesch and Hertwig, on the one hand, and Roux, on the other, drew opposite conclusions from the results of their experiments.

Roux regarded—as He did before him—each element of the embryo as imbued with its own specific organ-forming capacity, which he attributed to a substance termed by him its 'IDIOPLASSON.' The power of regenerating lost parts could not be attributed to the Idioplason; so, in order to account for it, a new substance, the 'RESERVE-IDIOPLASSON,' was invented, which came into play only when by experiment or accident one part was separated from the rest. Driesch, as we all know, boldly asserted the existence of an 'ENTELECHY' or arranging spirit which out of the material at its disposal constructed the organism which it knew and willed. Thus the inability of the upper half of a blastula, once the mesenchyme was formed, to produce a perfect larva was explained by Driesch on the assumption that as development proceeded the protoplasm became relatively more *stiffened* or stereotyped and less easy of manipulation by the entelechy, and the fact that the egg of a ctenophore would not endure the removal of a blastomere without giving rise to an imperfect organism was attributed to an early or precocious 'stiffening' of the protoplasm. Roux would have attributed many of Driesch's results to the action of his Reserve-idioplason, to which Driesch retorted that by a parity of reasoning all development might be construed as regeneration: 'everything is wanting at the beginning except a single cell, which regenerates all the rest.'

Hertwig did not go so far as Driesch in calling up spirits from the void; but his explanation must be characterised as vague and misty: he speaks, as we have seen, of the fate of a cell being a function of its position, and of the development of organs being a result of the reciprocal action of different cells on each other. But it is obvious that if differentiation is to spring from this an initial difference must exist; for the reciprocal action of similar cells on one another would give everywhere a similar result.

The next step in advance came from the study of molluscan eggs first by Crampton and then by E. B. Wilson, who confirmed and extended Crampton's results. In the eggs of certain Mollusca the first cleavage of the egg seems to divide it, not into two, but into three cells. The third 'cell' is, however, devoid of a nucleus, and, before the next cleavage, it melts into one of the two remaining cells. This transitory cell is known as the 'FIRST POLAR LOBE.' At the next cleavage five cells are apparently produced, but again one of these is a transitory 'SECOND POLAR LOBE' which melts into one of the remaining four before the cleavage following. After this cleavage a THIRD POLAR LOBE is extended and reabsorbed in the same way. The egg of a mollusc normally gives rise to a characteristic larva termed a TROCHOPORE: this, as all know, is a more or less spherical structure girdled by a belt of powerful cilia known as the PROTOTROCH, and having at the apex of one hemisphere a thickened plate—the APICAL PLATE bearing a tuft of long cilia. This hemisphere is known as the PRE-TROCHAL hemisphere; at the end of the other hemisphere, termed the POST-TROCHAL, is situated the embryonic mouth or blastopore. This opening leads into a sac-like gut, at the sides of which are situated two masses of mesoderm. Now

it is a comparatively simple matter to cut off either the first or second polar lobes by means of a very fine scalpel, and this is what Crampton and Wilson did. If the first polar lobe be cut off and the egg survives, it develops into a most peculiar trochophore. The shape is no longer spherical but hemispherical, and the flat surface is bordered by the prototroch; in a word, there is no post-trochal region. The apical plate, with its tuft of cilia, is entirely absent: the pre-trochal region is covered instead with a uniform layer of very fine cilia. No mesoderm is formed: the interior is filled up with a mass of endoderm in which a cavity is obscurely or not at all developed. If, instead of cutting off the first polar lobe, the second polar lobe be removed, a very similar larva is produced; as before, there is no post-trochal region produced and no mesoderm is differentiated, but a distinct apical plate with its wisp of cilia produced. We can only conclude from these experiments that there are distinct substances whose presence is necessary for the formation of the post-trochal region and of the apical plate respectively, that both these stuffs are concentrated in the first polar lobe, but that only the stuff necessary for the formation of the post-trochal part of the embryo is contained in the second polar lobe. Before the second cleavage of the egg has taken place the material necessary for the formation of the apical plate has become redistributed, and Wilson has been able to track it to its new destination. For, when the segmenting molluscan egg is subjected to the influence of sea-water free from lime, it breaks up into its constituent cells just as does the sea-urchin egg. When these cells are now replaced in ordinary sea-water they develop further, but they do not, like the separated cells of the sea-urchin egg, produce miniature perfect embryos, but, on the contrary, each continues its development as if it still formed part of the original embryo. The eight-cell stage in a molluscan egg consists of four large cells termed macromeres, and of four small cells termed micromeres. Now when these micromeres are separated and left to develop separately, in certain molluscan eggs at any rate, only one of the four micromeres will give rise to an apical plate, and this cell must therefore contain the special substance which was formerly in the first polar lobe. Therefore, in view of these facts, we are led to what I consider the great epoch-making discovery of experimental embryology, viz. the existence of SPECIFIC ORGAN-FORMING SUBSTANCES.

This conclusion is bitterly resisted by Driesch. He has no difficulty in showing that the conception of the developing organism as a machine composed of juxtaposed parts is a perfectly untenable one. For no conceivable machine could have its parts so arranged that one could cut a large portion out of it anywhere at random and yet have the possibility of forming out of the remainder an exactly similar machine of smaller size; and yet this is true of the blastula of the sea-urchin before the mesenchyme is formed. But if all the cells of this blastula contained a similar organ-forming substance, then we can understand how any sufficiently large portion of the blastula wall can round itself off and give rise to a perfect embryo. To this Driesch replies that it is impossible to form a clear conception of what an 'organ-forming' substance is. It is, of course, not an ordinary chemical substance: for the molecules of an ordinary chemical substance have not the power of 'crystallising' into arms and legs and other organs, and it can hardly be supposed that substances exist the individual molecules of which are miniature arms and legs. He therefore maintains that all these substances are merely 'conditions' which limit the powers of the entelechy to whose efforts the real activity in organ-formation must be ascribed. Now, this objection of Driesch raises a really fundamental question, which is: In what, after all, does 'explanation' consist? I think that close reflection on this subject will convince one that we think we have 'explained' a new phenomenon when we have successfully compared it with some older phenomenon which we regard as familiar and well known. Thus we imagine that we have 'explained' the eruption of a volcano when we have compared it, rightly or wrongly, to the explosion of an overheated steam boiler, and the law of gravitation which 'explains' the movements of the heavenly bodies is merely a comparison of these movements with the movements of an apple which falls from its parent tree to the earth. The explanation of development by an entelechy is at bottom a comparison of the forces moulding

an embryo to the purposeful endeavours of a man who is bent on building a house of a particular type and who takes whatever materials he can lay his hands on in order to effect his object. Now certainly purposeful endeavour is the most familiar of all the activities which we see around us, and there is therefore nothing wrong in Driesch selecting this most familiar of all phenomena in order to throw light on the development of the germ. The great objection to it is, I think, that it is unfruitful: it does not enable us to compare one kind of development with another. For we simply have to instal a different kind of entelechy with a different purpose in every kind of egg, and there the matter ends. On the other hand, there are records of phenomena, rapidly increasing in number with the extension of research, of which we can only give a rational account by postulating some form of the hypothesis of organ-forming substances: for in some cases these substances are actually visible to the naked eye in the living egg. We shall give a short account of the most striking instance of this, viz. the development of the egg of the Ascidian *Cynthia partita* as described by Conklin. This egg before fertilisation contains the usual large bladder-like nucleus or germinal vesicle characteristic of immature eggs. The mass of the egg consists of a cytoplasm rendered a slaty-grey colour by inclusions of yolk, but in its outermost zone are included many particles of a bright yellow pigment. When the egg ripens the germinal vesicle bursts and the clear fluid which it contains spreads out in a cap at one pole of the egg. Now, fertilisation takes place and the spermatozoon enters the egg at the opposite pole from that at which this cap of clear matter is situated. The effect of this entry—long before the male pronucleus has reached the female pronucleus—is as if the egg were struck by a whirlwind. All the yellow particles of pigment are sucked downwards towards the entering spermatozoon and so is the original clear substance. The female pronucleus descends from the upper pole to the centre of the egg, where it meets the male pronucleus and the yellow and clear substances form two concentric crescents around the posterior half of the egg. When segmentation of the egg begins and the egg divides into two, the yellow mass is likewise divided into two, and each half receives an inclusion from the yolky cytoplasm which becomes incorporated with it. Thereafter, during the subsequent stages of development, the clear, blue and yellow cytoplasm remain distinct from one another and as cell-division progresses they become gradually confined to definite cells. Then it becomes evident that the clear substance forms the ectoderm, the blue stuff the endoderm, whilst the yellow stuff forms the mesoderm and in particular the longitudinal muscles which flank the Ascidian tadpole's tail. That these substances are in reality essential for the formation of the organs in which they are situated is shown by the fact that when one of the first four cells is killed, and thereby one half of the yellow substance removed, the resulting tadpole has muscles only on one side of the tail. That the arrangement of these substances in the egg is due to some attractive influence radiating from the male pronucleus is proved by the circumstance that when an egg is entered by two spermatozoa the yellow material forms two crescents, one embracing each male pronucleus. Another most interesting conclusion to be drawn from the study of this development is that the separation of these substances corresponds to the DIFFERENTIATION OF THE GERMINAL LAYERS about which so much dispute has raged, and that the cutting up of the developing organism into cells is a phenomenon of secondary importance. For we find that both notochord and nerve cord arise from the same group of cells, termed by Conklin the CHORDA-NEURAL CELLS: but this is not to be interpreted as meaning that these organs were differentiated out of a common ancestral organ, because when these chorda-neural cells are closely examined they are found to include within themselves areas of both the clear and blue cytoplasm, and when they divide the clear and the blue regions are assigned to different daughter-cells, and the clear daughter-cells give rise to the nerve-tube whilst the blue daughter-cells grow into the notochord. We find in this an additional confirmation of Hertwig's view that the nuclei are all alike and endowed with all the potentialities of the organism, and that it is the cytoplasmic areas which become unlike each other. Of course Driesch may reply that the organ-forming substances are merely the conditions and not the effective causes of organ-formation. Putting aside the obvious retort that the

distinction between 'condition' and 'effective cause' is rather a metaphysical one, we may proceed to show that the supposititious indwelling entelechy can be entirely balked and misled in its aim by slightly different arrangements of the organ-forming substances. The eggs of the frog contain two different cytoplasmic substances easily distinguishable by the naked eye; one of these is of a dark colour, and the other of a light colour. When the experiment was performed of fixing a frog's egg upside down to a slide so that it could not rotate, and allowing it to develop in this position, it was found that the nervous system of the tadpole was still produced on the side of the egg which was uppermost. This can be understood when it is realised that the dark substance is of a lesser specific gravity than the white substance, and that the substances re-arrange themselves under the influence of gravity. If, however, frogs' eggs are fixed to one slide and compressed by having another slide clamped on the top of them, and are allowed to divide into two in this position, and if the slides be then turned upside down and the development allowed to continue, a double monster is produced—that is, a tadpole sometimes with two heads and sometimes with two tails. Now, Driesch defines his entelechy as a 'rudimentary psychoid which knows and wills what it wants to produce'; but we may safely affirm that no intelligent psychoid ever desired to produce a result like this, and in this case nothing has been either added to or subtracted from the egg. But if we try to give an explanation in terms of organ-forming substance, we succeed much better. We may assert with confidence *that the formation of a normal embryo is the consequence of the arrangement of the dark and light substances in a certain spatial relation to one another.* When the egg is inverted this fixed relation is maintained owing to the influence of gravity, since, as we have seen, the two substances have different specific weights; but when the egg has been divided into two and is then inverted, then the division plane between the two cells causes a readjustment of the positions of the two substances within each cell as if each cell were a whole egg, and thus arises the tendency for each cell to develop into a whole embryo. If the same experiment be tried with a newt's egg—in which, however, the various organ-forming substances are not distinguishable by the naked eye—the result is to produce, not a double monster, but two completely separate embryos. Now, if we analyse closely wherein lies the difference, in the distribution of these substances in the two-cell stage of a normal egg and of an egg which has been compressed and inverted during the first cleavage, we find that it can only consist of a slight re-entrant angle in the outline of the black substance as it crosses the division plane separating the two cells. In the normal egg the black substance forms an evenly curved cap in the two-cell stage; in the compressed egg this cap is bent inwards in the middle. Yet this slight difference is supposed to be sufficient to deceive the entelechy and balk it of the fulfilment of its purpose. In the newt's egg, where the materials are apparently more mobile, the re-entrant angle is more acute, and here the duplicity becomes so great as to produce two completely separate embryos. That the difference in outline is in reality the factor which causes the doubling is proved by a large number of additional experiments. Thus Herlitzka, experimenting, not with the segmenting egg but with the blastula of the newt, was able to show that, by constricting it with a fine hair so as to indent the anterior outline, he was able to produce a two-headed embryo; Loeb, by placing the blastulæ of the sea-urchin *Arbacia* before they had escaped from the egg membrane in water of diminished salinity, was able to cause them to swell so as to tear rents in the membrane and to produce extrusions of the blastular wall. These rounded extrusions begin to develop like separate embryos, forming their own guts.

We thus come to the conclusion that for the present we may dismiss the conception of the entelechy from our minds as a working hypothesis and adopt instead the conception of organ-forming substances, and we may now proceed to inquire what further can be learnt about these extraordinary materials. In some cases it can be shown that what determines the fate of a particular region of the embryo is, not the presence or absence of a certain substance, but its presence in greater amount than in neighbouring regions. The classic example of this kind of thing is the egg of *Ascaris*, the Nematode worm as worked out by Boveri. We are, most of us, aware that the development of this egg used

to be cited as the most convincing proof that the differentiation of the germ is the result of the differentiation of the nuclei. For when it divides into two cells the nucleus of the upper cell undergoes the remarkable change known as DIMINUTION OF THE CHROMATIN. There are at most four chromosomes in the fertilised egg: in the upper cell just after division a large portion of these is cast forth into the cytoplasm and absorbed, whilst the remainder breaks up into a large number of minute chromosomes. The upper cell gives rise only to ectoderm, whereas the lower gives rise to all the internal organs. Now, if an egg happens to be fertilised by two spermatozoa, a curious monster results, which may have any one of three forms in the four-cell stage. It may consist of two upper and two lower cells, and in this case it will develop into a complete twin embryo; it may consist of one upper and three lower cells—in this case it will develop into a monster with three sets of internal organs; or, finally, it may consist of three upper cells and one lower cell, in which case it will develop into a fairly normal embryo with an unusually voluminous amount of ectoderm. Now, Boveri, by an exhaustive analysis, shows that the assumption that the cause of the diminution of chromatin lies in the nucleus leads to conclusions which are totally at variance with the facts: that it must lie in some peculiar substance collected in one region of the cytoplasm; and that the different results obtained by double fertilisation are due to the accident that, of the four nuclei resulting from the first cleavage, one, two, or three may lie in the region containing this substance. But the most convincing proof is furnished by an ingenious experiment which we have been able to repeat in the laboratory of the Imperial College. If the fertilised eggs of *Ascaris* be fixed to a slide and put into a centrifugalising machine and a high speed of rotation be maintained for a considerable time, and the eggs divide into two whilst undergoing this rapid rotation, then it will chance that the planes of division of some of them from their position on the slide will be exactly radial. When this occurs both cells are exactly alike—neither nucleus undergoes diminution, and each cell gives rise to a set of internal organs; but the least obliquity of the plane of this division to the axis of rotation results in the formation of two cells, one of which exhibits diminution of chromatin in the normal manner, and gives rise to the ectoderm, whereas the other nucleus remains unaffected and the cell containing it gives rise to the internal organs. We may assume that the peculiar substance which causes diminution is driven to the outer part of the egg by the centrifugal force, but it is impossible to avoid the conclusion that, in an egg the plane of whose first division lies slightly oblique with regard to the axis of rotation, both the first cells must receive some of the substance, and yet only one nucleus undergoes diminution. Therefore the fact that one cell receives more of the substance than its fellow must determine the diminution of the chromatin and its subsequent development.

Having studied the general properties of these marvellous substances so far as the evidence at our disposal will permit, we must try to find out something of their origin. In the case of the egg of the Ascidian *Cynthia* the origin of one of them at least is obvious. For, as we have seen, the ectoderm owes its origin to the nuclear sap. But a little reflection will render it clear that in the last resort all these organ-forming substances must arise from the chromatin. For the father's contribution to the fertilised egg is merely a small mass of chromatin—the spermatozoon head—and yet organs are inherited from the father just as well as from the mother. Now, Schaxel has shown that when the unripe egg is examined it is possible by appropriate methods of staining to detect streams of chromatin granules both inside and outside the nuclear membrane, forming in many cases accumulations against the nuclear membrane and pointing in the clearest manner to the conclusion that chromatin material is being poured into the cytoplasm and is modifying its character. This is especially obvious in the unripe egg of *Cynthia*. Even the nuclear sap must be regarded as a by-product of the chromatin: for Gates has shown that when, as happens in the ripening of the pollen-cells of *Oenothera*, a piece of chromatin becomes detached from the nucleus of one cell and discharged into the cytoplasm of its neighbour, this piece acts like a miniature nucleus and surrounds itself with a nuclear membrane inside which is nuclear sap. It is thus seen that nuclear membrane and sap are both produced by the reaction of chromatin

with cytoplasm. A great deal of confirmatory evidence can be brought in favour of the view that the cytoplasm of the egg is at first homogeneous but is modified as growth proceeds by the agency of material emitted by the nucleus. Thus if the unfertilised egg of the Nemertine worm *Cerebratulus* be broken into fragments and spermatozoa added, the fragment which contains the nucleus alone will develop into a larva. If, however, we wait until the nuclear membrane has dissolved and the contents of the nucleus have diffused into the cytoplasm, then, when the egg is broken into fragments and the fragments fertilised with spermatozoa, each will develop into a larva. It is obvious that the whole quality of the cytoplasm has been changed by what has been discharged into it from the nucleus. And the same thing can be observed in the egg of *Ascaris*. We have just learnt that this egg when ripe has its cytoplasm sharply differentiated into zones, one of which contains the peculiar substance which determines diminution of the chromatin. But if the unripe eggs of *Ascaris* be subjected to centrifugal force, they can lose large portions of their cytoplasm and yet the diminished remnants containing the nuclei, if fertilised, will produce perfectly normal embryos of reduced size, showing that when the egg is unripe the cytoplasm is perfectly homogeneous. We are all aware that Weismann in his famous theory of the GERM-PLASM anticipated many of these conclusions. He also regarded the peculiar cytoplasmic qualities of the various cells of the body as caused by the emission of peculiar materials from the nuclei, but there is one fundamental difference between Weismann's theory and the view which we have been led to take as a result of all the experiments which have been described. Weismann supposes that the division of the nucleus, though it results in the formation of two apparently similar daughter-nuclei, is in reality in many cases a differential division and separates two different kinds of chromatin: and that the differences in the cytoplasm of various cells which become obvious as development processes are due to differences in the constitution of the nuclei which they contain. He supposes that the nuclei of certain cells from the beginning of development retain the constitution of the nucleus of the egg and that some of the descendants of these cells do the same and eventually give rise to the germ-cells, and he termed the supposititious pre-determined lineage of cells leading from the fertilised egg to the germ-cell a GERM-TRACK: these germ-tracks are then imagined to stretch in a continuous chain from generation to generation, transmitting their characters unaltered, whereas the other cells which constitute the body are a sort of by-product of these. Now, we have seen that it has been experimentally demonstrated that the nuclei in the blastula of the sea-urchin and in the earlier segmentation stages of the frog's egg are alike and can be interchanged with one another with impunity, and yet at the very period of the development at which this obtains most definite and distinct cytoplasmic differentiation can occur—at any rate in the frog's egg; therefore we are led to agree with Hertwig that all the nuclei of an embryo are potentially alike, and that in the case of many animals definite pre-determined 'germ-tracks' do not exist. Quite recently evidence strongly confirmatory of this view has been brought forward by Gatenby. This observer finds that in the common frog every season a new generation of egg-cells is formed by the modification of ordinary peritoneal cells. Previous observers had traced the first origin of the germ-cells back to a very early stage in the development of the tadpole and had maintained the existence of definite germ-tracks in this animal. But Gatenby, whilst admitting the truth of their observations, points out that these primitive germs would not suffice for the supply of eggs even for the first spawning season, and that the much more numerous eggs that are spawned in subsequent seasons are derived by the gradual modification of typical peritoneal cells, and that the first indication of this modification consists in the appearance of a blush of chromatin surrounding the nucleus—a blush which we may surely interpret as an emission of organ-forming materials into the cytoplasm.

We have so far discussed the appearance of organ-forming substances as if they were elaborated and discharged from the nucleus solely during the period of the ripening of the egg. This appears to be the case in such highly specialised eggs as those of Ctenophores, Mollusca, and Nematoda, but we have to consider the case of eggs like those of the sea-urchin and star-fish, which are

apparently quite undifferentiated in the earlier periods of development. Now, in our discussion of Driesch's experiments we have seen that when development reaches a certain point, the embryo ceases to be equipotential in all its parts. In the case of the sea-urchin this point is reached when the primary mesenchyme cells are being formed; now Schaxel has shown that the nuclei of these cells are surrounded by the familiar blush of chromatin, which points to the conclusion that the nuclei are again emitting organ-forming materials into the cytoplasm. It is after this event that we find that the upper half of the blastula is incapable of forming a gut. We cannot, however, conclude that ectodermic and endodermic substances are first formed at this stage, because then we could not account for the fact that in an earlier period of development any part of the blastula will, if cut off, heal up and form a small blastula capable of forming a gut. Rather the evidence forces us to assume that ectodermic and endodermic organ-forming substances begin to be formed shortly after fertilisation and continue to be formed for some time, but that at first they are not separated from one another, so that when segmentation occurs they exist side by side in the same cell; as development proceeds, the endodermic substances become gradually segregated towards one pole and the ectodermic substances towards another. We must think of the cell-walls as permeable to these substances; indeed, we must regard the protoplasm of the embryo as a whole in spite of its apparent division into cells. The best proof of this view is furnished by Herbst's well-known experiment of exposing the developing eggs of the sea-urchin to the action of the salts of lithium. We all know that eggs which have undergone this treatment develop into motionless blastulæ, whose walls later become differentiated into two regions—one corresponding to the ectoderm and one to the endoderm of a normal embryo. Such embryos, if replaced in normal sea-water, acquire the power of motion, and the part corresponding to the gut of a normal gastrula often shows signs of differentiation into œsophagus, stomach, and intestine—turned inside out. This 'LITHIUM LARVA,' however, is not formed unless the eggs are placed in the lithium solution immediately after fertilisation, or at least during the early stages of segmentation, and continue in it until they attain the blastula stage. Now, as the intensity of the action of the lithium salts increases, so does the proportion of the wall of the lithium blastula, which takes on endodermic characters till in extreme cases only a minute button representing the ectoderm remains, and in a few cases even this can disappear. It is obvious that the effect of the lithium is to increase the amount of endoderm-forming substance, and therefore this substance must be manufactured during the period of the egg's exposure to lithium salts; that is, after fertilisation up till the formation of the blastula. We see then that in eggs of this type the emission of organ-forming substances goes on after fertilisation: that these are only gradually localised and, *pari passu*, with their restriction to definite regions the power of all parts of the embryo to develop the whole organism is lost. Even Driesch was able to show that when 16-cell segmentation stages are broken into groups of cells, though all groups of any size can form miniature larvæ, those groups which belong to the lower half of the blastula develop more easily than the others, since their cells contain a larger proportion of endodermic substance.

The discovery that, in the case of some animals at least, the emission of organ-forming substances from the nucleus goes on after fertilisation encourages the thought that even in those cases where the organ-forming substances appear all to be formed before fertilisation and the nuclei are relatively passive during early development the nuclei may later resume their active rôle. Now, in two cases where, by the separation of the first two blastomeres, we are enabled to get half-embryos, it can be shown that the missing half is later regenerated. This is true of the frog, and is also true of the ctenophore. The ctenophore furnished us with such a beautiful instance of the limited potentialities of isolated blastomeres that it comes as a shock to learn that the exquisite half-embryos produced by separating the first two blastomeres can regenerate the missing half. This fact was first noticed by Chun, but has been confirmed by Mortensen. Now, the most natural way to explain this regenerative power is to attribute it to a renewed activity on the part of the nuclei in producing organ-forming substances. If we accept this view a good many curious facts about



regenerating organs receive an appropriate explanation. For instance, when the tail of a lizard is broken off it not infrequently happens that two tails are regenerated. This result can be artificially brought about by slightly injuring the regenerating surface. Here, then, we have another illustration of the principle that the number of organs of a given type produced by organ-forming substance depends on the outline of the germ. Where this is in a uniform curve, one is produced; if it is indented, two are produced.

Besides regeneration the phenomenon of budding is almost certainly to be referred to renewed nuclear activity in the production of organ-forming substances. It has long been a puzzle why in so many cases the development of the bud pursued a different course from that of the fertilised egg. Thus in the development of the bud of *Ascidians* the central nervous system is developed from the pharyngeal sac, whereas in the development of the ovum it is formed, as in the higher *Vertebrates*, from the ectoderm. But the ectoderm of the early embryo, as Hjört points out, is a layer of cells consisting of undifferentiated protoplasm, whereas the ectoderm of the bud is an extension of the maternal adult ectoderm, a layer of cells of hopelessly specialised cells irrevocably committed to the production of cellulose for the formation of the test, whose character could not be changed by the injection of any amount of organ-forming substance. Therefore the organ-forming substances are differently distributed, and chiefly poured by the active nuclei into the cells of the more plastic inner layer. If this view be admitted, we can see at once why the capacity of reproduction by means of buds is in general limited to animals of lowly organisation. It is not that the nuclei of the higher animals become limited in their potentialities: it is that their cytoplasm becomes too specialised to be modified in new directions. This is true even in the case of animals of simple organisation if they possess a strongly specialised cytoplasm, as, for instance, the *Nematode* worms.

We have now taken a brief survey of the evidence for the existence of organ-forming substances, elaborated by and emitted from the nucleus, which confer on the cytoplasm the power of forming the primary organs of the embryo. We have learnt that these substances aggregate themselves in centres, each of which tends to form an organ, and we can easily see that any influence, external or internal, which would tend to increase or diminish the number of the centres would correspondingly increase or diminish the number of similar organs formed from such substance. But, as we all know, these primary organs undergo further differentiation during the course of development into the secondary and definitive organs; and we shall now submit evidence that the formation of these secondary organs is determined, not by substances emitted from the nuclei of the primary organs to which they belong, but by substances absorbed from the blood or body fluid which have been produced by other organs. The first striking case of this was discovered by Herbst. As is well known, *Crustacea* are able to regenerate their limbs if these be cut off. Now, Herbst found that this is also true of the eye-stalk; if this be removed from a young shrimp, it will in time regenerate a new eye. But if the optic ganglion which lies beneath the eye be likewise removed, then, when the wound heals up, there will be produced, not a new eye, but an extra antenna. There seems to be no escape from the conclusion that, in normal development, the influence which compels the ectoderm to modify itself into the lenses, crystalline cones, and rhabdomes of the compound eye must be emitted by the ganglion cells of the optic ganglion.

Another striking case has been brought forward by Lewis. In the development of the Frog, as in that of other *Vertebrata*, the retina is formed by an outpushing of the embryonic brain known as the primary optic vesicle, and the lens is formed as an inpushing of the ectoderm of the side of the head. Now these newt embryos are very tolerant of operations: it is perfectly possible to slit open the skin and cut off the optic vesicle and yet the wound will heal up and the embryo will survive, only in this case no lens will be formed by the ectoderm on the operated side. But a still more wonderful experiment has been performed. The amputated optic vesicle has been inserted under the skin in a hinder region of the body: the wound has healed up, and the optic vesicle has

continued to live in its new situation and has caused the skin covering it to become modified into a lens-like structure. Hence we must conclude not only that the optic vesicle secretes a substance which acts on the skin covering it and compels this skin to become modified into a lens, but that all the skin of the body is capable of undergoing this modification if acted on by the appropriate stimulus.

A third instance of the same kind has come under my own notice. During the past few years I have been engaged in rearing large numbers of the pluteus of the *Echinus miliaris* in the tanks of the laboratory at the Imperial College. This pluteus is exceptionally favourable for observation because of its extreme transparency. Since the development of Echinoderms is a somewhat specialised branch of embryology, with which it is sufficient for most zoologists to cultivate only a bowing acquaintance, I may perhaps be forgiven for recalling to your minds the salient features of the development of this species. The plutei with which Driesch experimented were reared up till the stage when they possessed only four arms and a single pair of cœlomic sacs lying at the sides of the œsophagus. In their subsequent development, however, the number of arms is increased to eight, symmetrically arranged. Each cœlomic sac becomes divided into anterior and posterior portions, and from the anterior portion of the left side a small rounded vesicle, termed the HYDROCŒLE, is nipped off, which is the rudiment of the adult water-vascular system of the ring, the radial canals, and the canals of the tube feet. After its formation an invagination of the overlying ectoderm can be observed—this is the AMNIOTIC INVAGINATION. Its opening becomes constricted, so that the invagination becomes flask-shaped and finally closed, thus cutting off the sac from all connection with the exterior, so that we have an ectodermic sac overlying a cœlomic one. From the floor of this ectodermic sac are developed a series of pointed spines each with the characteristic neuro-muscular ring surrounding its base and also the sensory nervous ectoderm clothing the tube feet and from which the adult nervous system is developed. The posterior cœlomic sac extends forwards and intervenes between the stomach and the hydrocœle. From this sac are formed five outgrowths surrounding the hydrocœle, which form the pockets of Aristotle's lantern in the adult, from whose walls the teeth are developed. The stomach develops an outgrowth in the centre of this circle which is the rudiment of the œsophagus of the adult. On the right side of the larva there are normally developed two pedicellariæ each supported by a little calcareous plate on which later little square-topped spines make their appearance. Now, it occasionally happens, for reasons which I am investigating but have only succeeded in partially elucidating, that on the right side of the larva a second hydrocœle is developed from the right anterior cœlomic sac, and in certain circumstances it continues to develop. When this occurs, a second amniotic invagination is formed on the right side of the larva, from whose floor a second series of pointed spines is developed, whilst the pedicellariæ and square-topped spines, which should normally be formed, fail to put in an appearance. The right posterior cœlomic sac extends forwards between the second hydrocœle and the stomach and develops a series of pockets which give rise to a second Aristotle's lantern; whilst the stomach gives rise to a second larval œsophagus in the centre of these. We are thus driven to the conclusion that the ectoderm of the right side of the larva is just as capable as that of the left side of forming a nervous system and pointed spines, and that the right posterior cœlom can form just as well as the left posterior cœlom the complex structure known as Aristotle's lantern.

When I brought these facts to the notice of Driesch as being very difficult to explain on his theory of entelechy, he replied that he regarded them as an instance of twinning, *i.e.*, the formation of partial wholes, comparable to cases of the formation of Siamese twins. Now, undoubtedly such twinning can occur in Echinoderm larvæ. Gemmill has published a most interesting account of such twin larvæ of the star-fish *Luidia*, which he found developing from segmenting eggs which had been fertilised in the West of Ireland and sent to him by post. Gemmill rightly attributes the twinning to the partial separation of the blastomeres due to the shaking which they endured on their journey. But no

such explanation will fit the case we are considering. For the additional hydrocœle shows all degrees of development, and according to the degree of its development is the amount of influence which it exercises on the tissues of the right side. When it is comparatively small it may cause the formation of an amniotic invagination but may not be able to inhibit the formation of pedicellariæ, so that the characteristics of both sides of the larva are present together on the same side, and I have observed cases where it is still smaller and then it is unable to produce even an amniotic invagination, although it shows by its lobes, &c., that it is an unmistakable hydrocœle.

These observations show that we must accept the view that this marvellous structure, when once established, really does effect these wonderful transformations in what are relatively indifferent tissues by the materials which it exudes, and it seems impossible to suggest any modification of the theory of the entelechy which will fit this case. We can gather a suggestion of the possible answer to an objection raised by Driesch to the theory of organ-forming substances. Driesch says in effect this: If, considering the case of the regeneration of the legs of the tadpole when they have been cut off, we assume the existence of a material with the capacity of developing into a leg, how are we to explain the circumstance that when the leg is cut off at the knee the stump containing this supposititious substance regenerates not a whole leg but only the missing part? Now we find that the formation of a second hydrocœle can not only effect great changes in the adjacent tissues; it can also inhibit the formation of pedicellariæ. So we may well believe that when regeneration of an organ takes place, the presence of a portion of the organ to be regenerated may inhibit the organ-forming substance from producing a second edition of the same.

We cannot close this survey without allowing ourselves to reflect on the light which the fact we have related may throw on the cause of variation, which is one of the root problems of biology. We have been gradually led to view the nucleus as a storehouse of all the characters of the species, and to look for the cause of the first differentiations seen in development in the modification of the cytoplasm through the emission of substances from the nucleus; but to attribute much of the later development to the modification of one organ through the influence of materials emitted into the body-fluids by another organ, so that we may compare the organs of the growing body to an assemblage of semi-independent organisms which constitute an environment for one another. We all know from medical evidence that there exist certain organs of the body—the so-called ductless glands or ENDOCRINE ORGANS—whose secretions have enormous influence both on the growth and the function of all the other organs of the body. The question then inevitably occurs to our minds whether all the organs of the body may not exercise the same kind of influence on each other to a lesser degree. As St. Paul puts it: 'If one member suffers, all the rest of the body suffers with it.' Now, Dr. Cunningham put forward the idea that when an organ becomes modified in response to new conditions—as we know that organs can become modified—its chemical influence on other organs changes, and amongst others its influence on the genital cells. The substances which it emits are, we may suppose, taken up by these cells, and perhaps stored up by them in the genital nuclei. When these substances have been changed by reaction with a changed environment, these changed substances will be absorbed by the genital cells, and when these cells develop into new organisms the altered materials which they emit into the cytoplasm will tend to produce in it the same alterations as were produced by the changed environment even before the latter can act. In this way characters originally acquired in response to a changed environment may be conceived to become ingrained, as it were, in the organism. It has always been one of the great difficulties of the theory of the inheritance of acquired characters to conceive how a change in an external organ could, so to speak, cause a corresponding change in a genital cell; and if the change in the external organ be a mere mutilation, such as is produced by cutting off the tail of a mouse, for example, this difficulty is insurmountable, and there is no evidence whatever that such mutilations are ever inherited. And yet the negative evidence derived from such experiments has been adduced to prove the impossibility of the inheritance of acquired qualities! But when

the change in the external organ is of the nature of a reaction to a stimulus and when we contemplate the marvellous changes in growth due to minute quantities of organ-forming substances, then the problem becomes altogether changed, and the possibility of its solution brought nearer. The whole study of comparative embryology seems to support some such conclusion as this, for we find a constant tendency in the more specialised types of development for changes which must have corresponded to changes in environment to be pushed back to successively earlier stages in the life-history. As Hyatt has shown, the study of youth-stages of fossil Cephalopoda where the evidence is available points in the same direction. Now, we can find evidence of the same thing in these organ-forming stimuli. We have seen that the formation of an eye in the shrimp is due to an influence emanating from the optic ganglion, and that if eye and ganglion be both removed the wounded ectoderm heals up and forms an antenna. But if the same experiment be performed on the more modified crab a different result follows: whether the optic ganglion be removed or not, a new eye is regenerated. We may regard the optic ganglion as forming, as it were, a kind of internal environment for the ectoderm, and in the more modified crab the influences which radiate from this internal environment have become, so to speak, stored up in the nuclei of the ectoderm, so that these now have in themselves the capacity of the formation of an eye independently of any stimulus.

Of course, by experimental embryology we can never demonstrate the fact that the action of the environment ever is imprinted on the genital cells and that acquired characters actually are inherited. At most we can find examples of possible *modus operandi* of this influence. The final proof must be sought in breeding experiments. Before, however, we complain of the paucity of results obtained from these, let us clearly grasp the difficulties of obtaining a definite result at all in such a case. We may expose animals to a changed environment and observe that changes in their structure result; if we obtain offspring from them, and rear these in the normal environment, we shall most probably find that the change in structure has been entirely lost, and therefore many biologists infer that these environmental changes are not inheritable. But in drawing this conclusion such biologists entirely forget that, if a change from one environment to another causes a change in structure in one generation, a change in the opposite direction should be sufficient to reverse it in an equal amount of time. On the other hand, if a change in structure is only caused by a changed environment after exposure to it through a number of generations, then, when the changed offspring are retransferred to a normal environment, the changed structure should persist in a diminishing degree for a number of generations; but the successful carrying out of such an experiment would require a long period of years, and very few such experiments have been attempted. Kammerer, however, has published an account of such an experiment proving the inheritability of the effects of environment in the skin colour of the Salamander, which in my opinion is conclusive; and he rightly says that those who would follow in his footsteps and perform similar experiments must be prepared to consecrate to them a considerable portion of their lives.

In conclusion, we may say that the labours of experimental embryologists have allowed us to obtain a glimpse into the nature of the forces which transform the apparently simple and formless germ into the complicated adult animal, and, though at present we are unable to compare these forces with forces which act on non-living matter, yet at any rate we are enabled to classify them and to learn something about their laws of action; and this knowledge is an indispensable preliminary to any deeper knowledge of their nature to which we may hope that in the future we may be able to attain.

We have seen that Driesch's conception of an indwelling entelechy, though logically defensible, is useless and unworkable in practice, and that the conception of the existence of organ-forming substances fits in much better with the facts, although these hypothetical substances are very different in their nature from the ordinary chemical substances found in inorganic nature. Finally, we have seen that the growing organs of the individual constitute, so to speak, an environment for one another, and many features of the adult are due to

their interaction and the modifications they induce in one another, and that these modifications are similar in nature to those produced by the external environment, and, like the results of external influences, tend in time to become ingrained in the constitution of the organs on which they act. We are only at the outset of our knowledge of the subject, but the successes already gained in the brief period during which investigations of this kind have been carried on, and the paucity of the labourers in the field, justify our expectation of the most far-reaching results if investigations on these lines are perseveringly carried on.

It is a matter of the deepest interest that we are being driven step by step to a position which is in essential agreement with the underlying idea of that theory of PANGENESIS which was put forward by the founder of modern biology, at the conclusion of his long and patient study of the variation of the animals and plants under domestication, as the only conception which he could form of the causes of variation.

---

The following Papers and Reports were then received:—

1. *Exhibition of Lantern-slides illustrating the Mussel-fishery and the Life of Alcide d'Orbigny at Esnandes (La Rochelle).* By E. HERON-ALLEN, F.L.S.

---

2. *Bionomics of the Egyptian Bilharzia Worms.*<sup>1</sup> By Dr. R. T. LEIPER.

---

3. *Some Points of Bionomic Interest observed during the Visit of the British Association to Australia.*<sup>2</sup> By Dr. F. A. DIXEY, F.R.S.

---

4. *Report on the Occupation of a Table at the Zoological Station at Naples.*—See Reports, p. 238.

---

5. *Report on the Collection of Marsupials.*

---

6. *Report on Zoology Organisation.*

---

7. *Report on the Nomenclator Animalium Generum et Sub-generum.*

---

8. *Report on the Occupation of a Table at the Marine Laboratory, Plymouth.*

---

9. *Report on the Biological Problems incidental to the Belmullet Whaling Station.*

---

10. *Report on Biology of the Abrolhos Islands.*

---

11. *Chemical Entomology.* By F. M. HOWLETT.

---

<sup>1</sup> See *Proc. R. Soc. Medicine*, vol. ix. (1916), pp. 145-172.

<sup>2</sup> See *Entomologists' Monthly Magazine*, January-June 1916.

12. *Likes and Dislikes of Flies.*<sup>3</sup> By Miss O. C. LODGE.

13. *Military Entomology.* By F. M. HOWLETT.

---

THURSDAY, SEPTEMBER 7.

The following Papers were received :—

1. *The Exploitation of British Inshore Fisheries.*<sup>4</sup>  
By Professor HERDMAN, F.R.S.

2. *The Coastal Fisheries of Northumberland.*<sup>5</sup>  
By Professor A. MEEK, M.Sc.

3. *The Further Development of the Shell-fisheries.*<sup>6</sup>  
By Dr. JAMES JOHNSTONE.

4. *The Scheme of Mussel-purification of the Conway Fishery, a brief Description of the Method devised by the Board of Agriculture and Fisheries.*<sup>6</sup> By Dr. A. T. MASTERMAN, F.R.S.

5. *The Scales of Fishes and their Value as an Aid to Investigation.*  
By Professor A. MEEK, M.Sc.

6. *Some Notes on the Determination of the Age of Fishes by their Scales.* By Dr. A. T. MASTERMAN, F.R.S.

7. *Review of the Fluctuations of the Herring, Mackerel, and Pilchard Fisheries off the South-West Coasts in the light of Seasonal Variations of Hydrographical Factors.*<sup>6</sup> By Dr. E. C. JEE.

---

FRIDAY, SEPTEMBER 8.

The following Papers were received :—

1. *Amœbæ in relation to Disease.*<sup>7</sup> By Dr. PIXELL-GOODRICH.

<sup>3</sup> *Proc. Zool. Soc. London* (1916), part iii., pp. 481-518.

<sup>4</sup> See *Nature*; also *Annual Sea Fisheries Laboratory Report for 1916* (Trans. Biol. Soc. Liverpool for 1916-17).

<sup>5</sup> See 'Fisheries,' *History of Northumberland*, vol. vii.; also Report of Inshore Fisheries, Board of Agriculture and Fisheries.

<sup>6</sup> To be published in the 'Fishery Investigations' Series of the Board of Agriculture and Fisheries.

<sup>7</sup> See H. Pixell-Goodrich and M. Moseley, *Journ. R. Micr. Soc.*, December 1916.

2. *Notes on the Amœbæ from the Human Mouth.*<sup>8</sup> By Dr. T. GOODEY.3. *The Flagellate Protozoa associated with Diarrhœa and Dysentery.*  
By H. B. FANTHAM, M.A., D.Sc., and ANNIE PORTER, D.Sc.

At the present time, when the conservation of life is so important, it is well that attention should be directed to all the pathogenic organisms producing disease in man. *Entamœba histolytica*, causing amœbic dysentery and liver abscess, has had much attention directed to it, but until recently less notice has been taken of the Mastigophora associated with diarrhœa or dysentery in man. Between January and April 1916 we have taken an active share in and supervised the examination of some 3,800 stools from dysentery patients, and have conducted research on the same. The patients mostly contracted the infections in Gallipoli, but a few had never left England until they went to Flanders, while a very few became infected in England and had never been outside the country. More recently, one of us (H.B.F.) has examined the stools of a number of cases of diarrhœa and dysentery in the East, especially in Salonika.

The Mastigophora found in the stools include *Trichomonas hominis* (also called *T. intestinalis*), *Chilomastix (Tetramitus) mesnili*, *Giardia (Lambli) intestinalis*, *Cercomonas hominis* and *C. parva*. Both single and multiple infections of these flagellates with each other and with *Entamœba histolytica*, *E. coli*, *Isospora*, *Eimeria*, *Spirochæta eurygyrata* and *Blastocystis* occurred some patients exhibiting as many as five different organisms in their stools. The periodicity of the appearance of the parasites in the stools was found to vary with the different parasites. A short account of the essential features of each of these organisms will now be given.

*Trichomonas hominis* or *T. intestinalis* as found in the human intestine is pear-shaped, with three free flagella at the blunt or anterior end, a lateral flagellum being attached to the body by an undulating membrane, and an axial rod running towards the pointed end of the body from near the anteriorly placed nucleus. The flagellate measures about  $10\mu$  to  $15\mu$  by  $5\mu$ . Rounded contracted forms may be found in the fœces. Similar Trichomonads occur in rodents such as rats, mice, and rabbits. Possibly rats and mice act as reservoirs of the parasites. Trichomonads may also be water-borne. Mello Leitao (1913) found *T. hominis* in cases of relatively benign dysentery in Rio de Janeiro. Escomel (1913) found 152 cases of dysentery in Peru solely due to *Trichomonas*. We have found *Trichomonas* in some patients from Gallipoli, while in certain cases in Egypt these parasites were the cause of severe diarrhœa. With regard to treatment, the use of turpentine, thymol, and calomel, methylene blue and iodine irrigations have been recommended by different workers. Prophylaxis is directed to the prevention of contamination of food and water supplies by infected material, by rodent reservoirs and insect carriers, and to the isolation of pronounced human parasite carriers.

*Chilomastix (Tetramitus) mesnili*. This flagellate is allied to *Trichomonas*, but possesses a large cytostome, hence its former name of *Macrostoma mesnili*. Three anterior flagella are present, and a fourth one (perhaps attached to an undulating membrane) vibrates in the cytostome. An axial rod or axostyle is absent. The parasite measures about  $14\mu$  by  $7\mu$ . Encystment occurs. It has been found to be the cause of a colitis. Cases of *Tetramitus* diarrhœa have been frequently found in Salonika, and the disease also occurs in Egypt and Gallipoli. Pure infections of *Chilomastix (Tetramitus)* have been seen, and mixed infections of *Chilomastix* and *Trichomonas* have occurred in cases of persistent diarrhœa.

*Giardia (Lambli) intestinalis* exhibits bilateral symmetry. Eight flagella, arranged in four pairs, are present. The axostyle may be double, and two karyosomatic nuclei are present. A concave sucking disc occurs on the under surface. Two parabasal granules, often situated near the middle of the

<sup>8</sup> See *Parasitology*, vol. ix., part ii., 1917.

axostyle, are seen. The organism is from  $10\mu$  to  $2\mu$  long and  $5\mu$  to  $12\mu$  broad. Multiplication by longitudinal binary and multiple fission occurs. Resistant cysts are produced. These finally contain four nuclei, the remains of the axostyle and the parabasal bodies. The cysts serve to spread the parasite. *Giardia* was found to be the commonest flagellate infection in the stools of soldiers from Gallipoli examined by us, 471 stools out of 3,800 examined in three months containing this Protozoon, while on 137 occasions it was the only Protozoon present. The stools were sometimes of peculiar colours and consistencies, and were often bulky and diarrhœic in character. There was a distinct increase in the number of mononuclear leucocytes and lymphocytes in the blood of the patients. By enumerative methods it was found that there was a greater uniformity of distribution of cysts in a diarrhœic stool than in a semi-solid or formed one. The number of cysts in a bulky stool was calculated to be 14,400,000,000, the bulk of the stool being 950 c.c. In a stool of average volume the number was 324,000,000, the bulk being 150 c.c., while in a small stool of 50 c.c. volume 10,000,000 cysts were found. As each cyst, produced from a suctorial form, is resistant, efforts should be made to attack the flagellate form, which is probably most numerous in the intestine when cysts are few in the fæces. The periodicity in the appearance of the maximum crops of cysts varies slightly in different cases, the period being about a fortnight in some and a little less in others. *Giardia* may produce severe diarrhœa in children.

We have shown experimentally that *Giardia* of human origin is pathogenic to kittens and to mice. Animals fed with contaminated food became emaciated, suffered from either persistent or recurrent diarrhœa, and in most cases died. Erosion of the intestinal cells by the *Giardia* occurred, and blood and shed epithelial cells were found in the fæces. Sections of the intestine showed such epithelial erosion and abscessed conditions. The virulence of different strains of *Giardia* varies, and the cysts can remain infective for some time. Rats, mice, and cats can act as reservoirs of the disease. By contaminating the food or drink of man with their excrement, they may propagate lambliasis. Noc and others have found lambliasis among patients whose homes were infested with rodents. Bismuth salicylate was found effective in reducing the number of parasites, the cysts disappearing in some cases.

*Cercomonas hominis* and *C. parva* occurred in some of the dysenteric stools examined by us. They were not very common. The parasites were active, the nucleus was distinct, and the flagellar movements were pronounced.

#### References.

Fantham, H. B. (1916). The Nature and Distribution of the Parasites observed in the Stools of 1305 Dysenteric Patients. *Lancet*, June 10, 1916, pp. 1165-1166.

Fantham, H. B. (1916). Protozoa in 'The Animal Parasites of Man.' Bale and Danielsson, London. See pp. 54-62, 623-625, and 734-737.

Fantham, H. B., and Porter, A. (1915). Protozoa found in cases of Dysentery from the Mediterranean. *Proc. Cambridge Philosoph. Soc.*, vol. xviii., pp. 184-188.

Fantham, H. B., and Porter, A. (1916). The Pathogenicity of *Giardia* (*Lamblia*) *intestinalis* to Men and Experimental Animals. *Brit. Med. Journ.* July 29, 1916, pp. 139-141.

Porter, A. (1916). An Enumerative Study of the Cysts of *Giardia* (*Lamblia*) *intestinalis*. *Lancet*, June 10, 1916, pp. 1166-1169.

---

#### 4. War and Eugenics. By HUGH RICHARDSON, M.A.

---



## SECTION E.—GEOGRAPHY.

PRESIDENT OF THE SECTION: EDWARD A. REEVES, F.R.G.S.

WEDNESDAY, SEPTEMBER 6.

The President delivered the following Address:—

*The Mapping of the Earth—Past, Present, and Future.*

[PLATES V. AND VI.]

WE meet to-day under exceptional circumstances. The great war is affecting us all; those of us who are not actually engaged in it find that our lives are more and more under the influence of the great struggle that is now taking place, and are being called upon to do what we can to carry on the work of the men who have gone, as well as our own. This is the explanation of my presence here to-day. Mr. D. G. Hogarth, who was to have been our President this year, has been compelled to resign owing to his absence from England on important military duties; and a week or two ago I received a letter from the Secretary of the Association asking if I could help out of the difficulty in which our Section was placed by agreeing to take the chair during the meeting. Well, there seemed nothing else for me to do but accept, so I am here, and will do the best I can to fill the gap. With your kind indulgence, and the invaluable help and guidance of the recorder, secretaries, and committee, I trust we shall manage to get through somehow without bringing discredit on ourselves.

You will understand that, as the notice was so short, I have had no time to prepare an address such as I should like to place before you; and that which I shall now give has been hastily put together during a few days' holiday at the seaside, from notes and jottings I have recently made for other purposes, combined with such remarks as I feel may be appropriate to the circumstances and conditions under which we meet.

This is a great testing time—a crisis in our history when theories are put to practical trial, and I fear many of them will be weighed in the balances and found wanting. Scientific training is specially being tested, and almost every branch of human knowledge has, either directly or indirectly, been called upon to do its utmost in connection with the great War. This is no less true of surveying and geography generally. There has always been of necessity a close connection between military operations and map-making, and it is not too much to say that one of the essential conditions of successful warfare is a good and accurate knowledge of the geographical features of the theatre upon which the operations have to be carried out. Many a battle has been lost in the past, as we ourselves know to our cost, through imperfect topographical or geographical knowledge. The South African campaign, without referring to any others, produces more than enough evidence of the serious results ensuing from imperfect maps; and at the present time the general staffs of all combatants seem more than ever alive to the importance of this subject.

There are various ways in which this War will affect the map-maker; not only will new boundaries have to be surveyed and laid down; but outside of Europe districts will have to be mapped of which little information has hitherto

existed, so that, after all is over, our present maps and atlases will be out of date, and the publisher will find himself called upon to produce new ones.

It therefore appears to me that this is a suitable occasion for taking stock of our position, and I will endeavour to give you :

- (1) A brief general summary of what has been done in the past towards the mapping of the earth's surface;
- (2) a sketch of how things stand at the present time; and
- (3) finally add a few remarks upon future work, specially as regards instruments and methods.

You will perceive at once that this is a large subject, and in the time at my disposal I shall only be able to deal with it in the briefest possible manner.

The acquirement of knowledge has always been progressive, sometimes moving slowly, at others more rapidly, but ever advancing; and this is specially true of the subject we have to consider. Our present knowledge of the earth, its form, size, the configuration of its surface features, their measurement and representation on maps as we see them to-day, are the result of many centuries of strenuous endeavour and conquest over obstacles, and at times almost insurmountable difficulties, the record of which constitutes a striking monument to indomitable courage and perseverance such as cannot be excelled in the history of mankind.

Of all branches of human research and discovery that of geographical exploration and representation of the surface features of the earth is doubtless one of the oldest; in fact, it is difficult to imagine a time in the history of intelligent man when it did not in some manner or other exist. The earth's surface is, by the nature of things, man's present dwelling-place, and, however high and far he may soar in imagination and thought, as to his bodily presence his movements and operations are restricted to the crust of the comparatively small planet he inhabits. By his very nature man is an adventurer and a restless wanderer; and, since his physical constitution does not permit of his travelling more than a comparatively few feet vertically, his only chance of expansion is laterally or horizontally; and geographical investigation and measurement became a natural consequence.

From the earliest days there would arise the need of some sort of plans and maps; there would soon be boundary questions to settle, and the limits of pasture-lands, and irrigation rights, mining-claims and other matters would call for maps of some kind, however rough they may have been; so it is quite impossible to say when surveying commenced. It certainly must be one of the oldest departments of knowledge, and, like all others, has slowly advanced as the centuries have passed and greater accuracy was required until it has reached the refinement and precision of the present day.

Probably the earliest attempts were those which naturally resulted from the necessity of representing in some kind of plan the limits of private property, and several interesting examples of this have been brought to light during archaeological investigations and discoveries in Egypt and other ancient sites.

A careful reader of the account of the dividing of the land of Canaan among the tribes of Israel can hardly fail to come to the conclusion that Joshua had some sort of a map of the land before him when he proceeded to apportion the various districts, the boundaries of which are so minutely and carefully described; and it is also more than probable that he and others who had been sent beforehand to spy out the land 'had in view quantity as well as quality,' as Gore says in his 'Geodesy,' which implies some kind of rough survey and sketch map.

At a later period we have the vision of the man with the measuring line in his hand, measuring out his thousands of cubits, apparently much as a chainman does his work to-day.

So long as the district concerned was of no great extent there could have been little difficulty about making a rough plan or map of it. For lineal measurements the most natural units would be the lengths of various parts of the human body, the cubit, the pace, the foot and the span were evidently amongst the earliest standards of all, and most of these have remained in use until this day. With these, and an elementary knowledge of some of the simpler geometrical

figures, it would be easy for quite useful plans to be constructed, as indeed we know was the case.

The longer distances were reckoned by the time it took to travel from one place to another, days' journeys, &c.; and later on in stadia, of which it is generally assumed that there were 600 to a degree according to the ordinary Greek measure.

When distinctive features were visible it would be comparatively easy to map roughly a route travelled, much as a man in the present day can make an approximate sketch to show any journey he has taken, even without a compass or other instruments; or natives have been able to draw rough sketches to explain to explorers the direction of any coast line, or course of a river. One of the most recent examples of this is the map reproduced by Mr. Beaver, which was drawn in the sand by a native of Papua to show the relative position and names of the various tributaries of a river he was exploring (see 'Geogr. Journal,' April 1914).

Long before the magnetic compass was known, at any rate in Europe, navigators and travellers had to find their way somehow, often through little-known regions, and, when they had no landmarks to direct them, would have to seek some other means of guidance. Early nomad peoples of the desert would soon become acquainted with the heavenly bodies and their general movements and positions, and would naturally turn to them for the guidance they sought. Their positions at certain times and seasons would, through being continually observed, become quite familiar, and so doubtless before any instrumental astronomical observations for fixing positions were made, men learned to march and steer their ships by the sun by day and the stars by night. It is interesting to note that the art of marching by stars has been considerably revived in the last few years, specially in the rapid movement of troops at night.

So long ago as the seventh century B.C., Thales had taught the Ionian sailors to steer by the Little Bear, as did the Phœnicians.

One of the most interesting exploring expeditions of ancient times was that of Pytheas, the discoverer of Britain, in the third century B.C., who had not only learnt to sail by the stars, but determine the latitudes of points throughout his voyage by astronomical observations, made with a gnomon or sort of sundial, with which he seems to have fixed the latitude of Marseilles with far greater accuracy than might have been expected.

The gnomon used by Pytheas was probably of the earlier form, which consisted merely of an upright rod in the centre of a flat disc, but Aristarchus, in the third century B.C., introduced a decided improvement in the design of this interesting old instrument, which deserves to be borne in mind by all surveyors, since it seems to have been the first by which angles could be measured directly without computation. He substituted for the flat disc, or plate, a hemispherical bowl, in the centre of which an upright rod was fixed equal in length to the radius of the bowl. Concentric equidistant semi-circles were drawn on the interior of the bowl, which became a scale for the direct measurement of angles of altitude as indicated by the shadow of the rod or gnomon.

The voyage of Pytheas is of special importance, since it shows that even at that early date serious attempts were made at carrying out geographical exploring expeditions, by sea at any rate, on scientific lines.

The first record of anything that could be considered as the beginning of geodetic surveying was the well-known attempt of Eratosthenes to ascertain the size of the earth by the measurement of an arc of the meridian. This wonderful old philosopher was born in Cyrene in B.C. 276, and was so noted for his learning that he was put in charge of the famous library at Alexandria. The method he adopted was much the same in principle as that upon which geodesists at the present time work, but it seems impossible to say how near the truth his results were, as there is a doubt as to the length of the stadium he used.

The subject of the true form and dimensions of the earth is a most important one in many respects, and considerably affects survey questions, since it must form the basis of all exact measurements on the earth's surface. Right on to the present day geodesists have been working at it, and although they have brought down the probable error in the measurements to a minimum, yet even now the question cannot be taken as finally settled.

As regards the maps of very early date, it has always been a question as to how far they were the outcome of mere information collected by travellers without any attempt at instrumental measurement, and how far they were based upon some kind of route-surveying and astronomical determinations. At sea, as has been shown, occasional observations were made to determine latitude, but the actual charting of the coast-line, it is more than probable, was sketched in in the roughest possible manner, with little assistance from any kind of instruments. After repeated voyages the navigators would naturally obtain some acquaintance with the general configuration of the coast-lines and be able to draw a fairly accurate chart. These rough sketches were sent from one to another and copied by hand by cartographers; so in course of time quite a good representation was produced. It is indeed remarkable how accurate some of these old charts were. A rough latitude could always be obtained from observation, but it was quite another thing with longitude. Even at the present day there is far more uncertainty about a longitude observation than a latitude, and in early days, before the construction of accurate chronometers, to obtain the difference of time or longitude between two places was a problem which could not be satisfactorily solved with the rough instruments and tables available. Consequently the longitudes on early maps were, as a rule, very wrong. They were generally much too great, as the tendency was, as it is indeed at the present time, to exaggerate the distance travelled.

As might be expected, now and then serious mistakes seem to have been made in the fitting together of sections of charts received from various sources. This was probably due to the fact that in many cases they were rough copies from other copies of the originals, and, with no proper means of settling the orientation, the chart would, as likely as not, be fitted on to another at quite a wrong angle. This is doubtless the explanation of some of the grosser errors on many of the old maps. For instance, in the early editions of Ptolemy's maps, 1462(72)-1490, to the north of England there is a remarkable mass of land running something like east and west, and projecting a long way in the former direction. This is, of course, meant for Scotland, but it is difficult to see how it could have got so wrongly drawn. Yet if you suppose the whole mass turned round at right angles, so that the part that goes to the east is placed to the north, you get a much better representation. There seems little doubt that somehow or other the whole thing has got wrongly joined on to England. In later editions of Ptolemy it was corrected.

The best-known of all the old instruments is the Astrolabe, which is generally supposed to have been invented by Hipparchus about B.C. 150. Ptolemy, and many others after him, introduced modifications in it, some of which were doubtless improvements, while others, as is the case with many so-called improvements in more modern instruments, were of doubtful value or merely unnecessary incumbrances. Divested of all elaborations, the astrolabe consisted of a somewhat heavy metal ring suspended from the thumb, or, in the case of the larger instruments, hung on some form of tripod arrangement. Pivoted at the centre was the movable sighting rule or alidade, and the altitude of the sun or star was read off on the graduated circle round the circumference of the disc.

During the mediæval ages things were at a standstill, or rather went backwards, as regards all scientific pursuits, at any rate in Europe. This in a special manner affected geography and map-making. The advance that had been made by the Greeks was arrested, and the knowledge they had gained was lost sight of; instead of maps being improved by more accurate surveys of explorers and travellers, they were frequently drawn in monasteries by monks from imagination, more or less distorted by religious bigotry. Cartography fared somewhat better in the hands of the Arabs, but many of the maps seem to have been constructed under the impression that the outlines of all parts of the world must be formed by straight lines and arcs of circles, drawn with a ruler and compass, so that they are of little real value. There were, however, a few notable exceptions.

It was not until the latter part of the fifteenth century, the time of the great Portuguese and Spanish discoveries, that any real advance was made, but then Europe seemed to awake from a long sleep, and a grand new start was made.

One of the first acts of King John II. of Portugal (1481-95), whose memory

deserves to be equally held in respect with that of his great uncle Prince Henry, was the calling together of the Committee, or 'Junta,' of learned men to consider the best means of finding the latitude when the Pole-star was too low to be of service, to decide upon the most approved form of instrument for the taking of observations, and to furnish suitable tables of declination, &c., for the computations. Equipped with the new tables, which may, perhaps, be considered the first Nautical Almanac, and the simplified astrolabe, the Portuguese navigators started on the famous voyages, with a much better chance of properly fixing positions than their predecessors. The vernier had not yet been invented, and so the difficulty of obtaining accurate readings of the circles was still considerable. To overcome this difficulty it was decided to construct astrolabes with very large circles, and the instrument carried by Vasco da Gama in his famous voyage round the Cape in 1497 had a circle which measured just over two feet in diameter. The size of the instrument certainly made it unwieldy, and so it was necessary to suspend it from some sort of stand, which meant that it could not have been used with much success on board ship. Vasco da Gama seems to have been fully alive to this, and so we find him, when he arrived at St. Helena Bay, not far from the Cape, bringing his instrument on shore and fitting it up on a stand. His observation and method of obtaining the latitude of this spot is of considerable interest, and may perhaps be taken as a fair example of the kind of work that was then done.

The sun's meridian altitude measured was  $76^{\circ} 20'$ , which gave a zenith distance of  $13^{\circ} 40'$ . The declination found from the tables was  $19^{\circ} 21'$  S., so by adding this to the zenith distance the resulting latitude was  $33^{\circ} 0'$  S. I have recently tried to find out how near this was to the true latitude, but it seems to be difficult to say exactly where the instrument was erected. If we take the head of the bay as the spot, the error is apparently  $13'$ , since the latest Admiralty chart gives  $32^{\circ} 47'$  S. This error appears to be somewhat larger than might have been expected, but still, taking all things into consideration, it was not so bad after all. I have on several occasions made altitude observations with rough home-made instruments of the astrolabe type, to see what could reasonably be expected, and have found that with care it is possible to get a latitude with an error not exceeding  $5'$  to  $7'$ , taking a mean of several readings.

The difficulty of taking anything like accurate observations at sea was for centuries a very serious one, and long before the invention of the reflecting quadrant or sextant many were the attempts to devise some instrument for accomplishing this.

Next to the astrolabe, and various forms of quadrants with a sighting arrangement and plumb-bob, the old cross-staff came into use. This consisted of two rods or pieces of wood at right angles to each other. The shorter piece had a hole in the centre, and was made to slide along the other. The eye was placed at the end of the long piece, and the sliding piece or cross moved along until one end of it cut the sea horizon and the other the sun. The altitude was then read off on the long staff, which was graduated for the purpose. This was essentially a seaman's instrument, and was in common use about 300 years ago—in fact, until the famous old Arctic explorer, Capt. John Davis, of the sixteenth century, improved upon it by bringing out his 'Back-staff,' which enabled a man to take altitudes with his back to the sun instead of half blinding himself by looking straight at it.

With instruments such as these only the roughest measures could be obtained, and it was not until the ingenious invention of the reflecting octant, suggested first of all by Sir Isaac Newton, that anything approaching accuracy was possible. Hadley's quadrant was the first of such instruments to be put into actual use, but there is no doubt that the idea should be ascribed to the famous Sir Isaac Newton, although the instrument was probably independently invented by Hadley.

With the invention of the sextant, or its predecessors the octant and quadrant, rapid progress was made in improvements in navigation and surveying instruments.

The introduction of the Nonius by Peter Nuñez in the middle of the sixteenth century, and later of the Vernier by the Frenchman Francis Vernier, which,

owing to its simplicity, soon superseded the former, were of great importance, since it was no longer necessary to construct the enormous large arcs and circles which had hitherto been indispensable to give anything like accuracy.

The magnetic compass not only made an enormous difference in navigation and exploration by sea, since it enabled the sailor to launch boldly out into the unknown oceans with confidence, but it soon began to leave its mark on land-surveying and geographical exploration. Much has been written on the invention of the compass, and many have been the disputes upon the subject, but it was certainly in use in Mediterranean countries of Europe as early as the twelfth and thirteenth centuries. The date when it was first used for land-surveying is not known exactly, but in Europe it was probably about the early part of the sixteenth century.

For the filling-in of the topographical features early forms of the plane-table, or their prototypes the trigonometrer and graphometer, came into use in the sixteenth and seventeenth centuries. Besides these the surveying perambulator, such as is used at the present time, was a favourite instrument in measuring distances along roads, and many of the road maps of England before the Ordnance Survey were made by its means, combined with compass-bearings and circumfactor angles.

It is supposed that Ptolemy was fully alive to the fact that it was not necessary to actually measure the whole length of an arc of the meridian, but that some parts could be computed, or perhaps graphically obtained, much as is now done in plane-tying; but, so far as we know, the first to introduce triangulation from a measured base and angles was Willebrod Snell, a mathematician of the Netherlands, who lived in the seventeenth century. The account of his triangulation for obtaining the distance between Alkmaar and Bergen-op-Zoom, in Holland, is well known, and it is not necessary for me to refer to it in detail here; but its importance cannot be overestimated, since it laid the foundation for all future work. Much has been done in later years, but this has only meant the improvement of Snell's system, the perfecting of instruments for the measurement of angles and bases, and more refinement in the computations.

Of all the instruments used by the surveyor, there is doubtless none more important than the theodolite, which seems to have been first of all invented by Leonard Digges. His invention is described in his book on surveying, which was completed by his son and published in 1571.

There is an interesting old theodolite of much the same design in Bleau's famous Dutch Atlas of the latter part of the eighteenth century.

The 'common theodolite,' as it was called, since it had no telescope, carried by Mason and Dixon to the United States, and used by them in their survey of the boundary between Maryland and Pennsylvania in 1763-9, is now in the R.G.S. Museum. It was made by Adams, of London, and was evidently only intended for observing horizontal angles. It resembles what is generally known as a circumferator more than a theodolite. The famous Ramsden theodolite, which was used on the primary triangulation of the British Isles and later on in India, has often been shown in books, and doubtless many of you are quite familiar with its appearance. This has found a final resting-place in the Ordnance Survey Office, Southampton.

The surveying equipment of the pioneer explorer of early days, say, of from twenty to sixty years ago, usually consisted of a sextant and artificial horizon, a chronometer or watch, prismatic compass, boiling-point thermometers, and aneroid. With the sextant and artificial horizon the astronomical observation for latitude and longitude were taken, as well as those for finding the error of the compass. The route was plotted from the compass bearings and adjusted to the astronomically determined positions. The latitudes were usually from meridian altitudes of the sun or stars, and longitudes from the local mean time derived from altitudes east or west of the meridian, compared with the times shown by the chronometer, which was supposed to give Greenwich mean time.

The sextant, in the hands of a practical observer, is capable of giving results in latitude to within 10" or 20", provided it is in adjustment, but the difficulty is that the observer has no proper means of testing for centering and graduation errors.

The great drawback to the sextant for survey work is that it is impossible to take accurate rounds of horizontal angles with it, since, unless the points are all on the same level, the angles must be too large. It is essentially a navigator's instrument, and nowadays has been almost entirely superseded by the theodolite for land-surveying.

As regards the longitude, the difficulty was always to obtain a steady rate for the chronometer, owing principally to the unavoidable oscillations and concussions met with in transit. Formerly it was customary to observe lunar distances for getting the Greenwich mean time instead of trusting to the chronometers, but these, even with the utmost care, are very unsatisfactory.

In more recent years the occultation of a star method of finding the Greenwich mean time superseded almost entirely the lunar distance, but all of these so-called 'absolute' methods of finding longitude are fast becoming out of date since the more general introduction of triangulation and wireless telegraphy.

Heights of land were usually obtained by the boiling-point thermometer or aneroid.

This then was the usual equipment of the pioneer. With such an outfit the greater part of the first mapping of Africa and other regions of the world was carried out, with results that were more or less reliable according to the skill of the explorer and the time and opportunities at his disposal.

In recent years considerable improvement has been made in the instruments and methods of the geographical surveyor: the introduction of the Invar tape for the measuring of the baselines, the more general application of triangulation, the substitution of the theodolite for the sextant, the use of the plane-table for filling in the topographical details of the survey, the application of wireless telegraphy to the determination of longitudes, these and other improvements have all tended to greater accuracy and efficiency in geographical and topographical mapping, so that in many respects the rough approximate methods of the earlier explorers are fast being superseded by instruments and methods more in keeping with modern requirements in map-making.

Still, the principle underlying all surveying is the same, and the whole subject really amounts to the best and most accurate methods of measurement with a view to representing on a plane, on a greatly reduced scale, the leading features of a certain area of the earth's surface in their relatively correct positions; and so it resolves itself into geometrical problems of similar angles and proportional distances. This being the case, it is clear that it becomes in the main a question of correct angular and linear measurements, and all the improvements in survey methods have had for their object the increased accuracy of accomplishing this, together with greater facility for computing the results.

What we do now is exactly what was attempted by the early Greek geometers and others in ancient times, only we have far more accurate instruments. If, for instance, we compare our modern micrometer theodolite with the old scaph of the Greeks the contrast is striking, although both had the same object in view as regards taking altitudes of heavenly bodies. Many of the old instruments, in spite of their great size, were extremely rough, and the angles could only be read with approximation or to a great extent by estimation, while the theodolite, which is now generally used on geographical surveys, although it has circles of only five inches in diameter, can, by means of the micrometers, be read to 2" of arc, or even to 1" by careful estimation. This, when one comes to think of it, is a triumph of refinement, since it really means that we can measure to within about  $\frac{1}{83333}$  part of an inch, which is the space occupied by 1" on the arc of a circle of five inches diameter. At least this is the theoretical accuracy, but in practice there are, of course, errors in sighting, setting the micrometer wires, and those arising from other sources which have to be taken into consideration.

The continued striving after greater accuracy of measurement applies not only to angular measuring instruments, but to linear distance measurement as well; and the improvements in apparatus for this purpose, could we follow them in detail, would be most interesting. From the rough methods that would suggest themselves naturally to early intelligent men, and some of which I referred to in the earlier part of this address, to the modern baseline apparatus, and accurately computed sides of a geodetic triangulation, is a far cry, and the advance

in this matter is certainly remarkable. What would the ancient geographers have said if they were told of the accuracy of a modern first-class triangulation, such as that of our own Ordnance Survey or of the Survey of India?

Still absolute accuracy of measurement of any kind seems to be an impossibility, and the best we can do, after all, is to approach it as near as we can, and to arrange matters so that the inevitable errors will tend to balance one another. Nature herself seems to object to perfection in measurement. For instance, when we attempt to measure a distance, and have taken all precautions we can, changes of temperature occur and alter the length of our measuring-tape, and, in spite of all that has been done by manufacturing tapes of alloys of different metals in order to counteract this effect, uncertainty must exist to some extent. Then as regards our angular measuring instruments, not only must there always be personal error and some imperfections in the graduation and centering, but the change of temperature again comes in, affecting the metal, and attempting to defeat our object of obtaining perfection. If we desire to measure the true vertical angle, there is always the troublesome and uncertain effect of the refraction of the atmosphere, which makes the mountain-top appear in a different place from where it really is, according to the heat, moisture in the air, and all sorts of other unknown causes which, in spite of all the corrections we may apply, occasion at least some uncertainty as to our result, whilst, in the case of the sun or star, it is considerably worse. So great is this refraction that when the sun appears to be just above the horizon, as you see it over the sea, it is actually not there at all, and has gone down below the horizon. Of course tables have been constructed to correct for all this, but no one can say that they are really accurate, as the results depend so much upon local conditions, and they must after all be considered merely devices for making the best of a bad job. Then, again, when we have taken all possible care with the levelling of a theodolite, Nature, through inequalities of gravity, has an unsuspected trick of drawing the level out of its normal position, which introduces uncertainty, and is often most bewildering in its result. But enough has been said on this subject. The only safe rule for a surveyor to follow is never to assume that he is correct, and to take his observations so that they tend to compensate one another, whenever it is possible to do so.

So far what I have said has had chiefly to do with some of the earlier attempts at surveying and map-making, and the instruments and methods by which these have been carried out; and I will now try to give you an outline of what has been done in comparatively recent times, and state briefly the present position of various parts of the world as regards the condition of their mapping and the survey basis upon which their maps depend.

Little by little civilised man, by his daring, his love of adventure, and the necessities of events and circumstances, has penetrated into the unexplored parts of the earth and pushed back the clouds and mists that so long shrouded them from his knowledge, until at the present time the regions that are entirely unmapped are very few indeed, and do not amount to more than about one-seventh of the whole land-surface of the globe, including the unexplored areas of the Polar regions, which may be either land or water. Not content with a mere vague acquaintance, he has striven for greater accuracy, and has turned to various branches of science and called them to his aid, in order that he may obtain more correct knowledge and a better comprehension of the earth's features. To enable him to fix with definiteness the position of places upon its surface, map out the various land-forms, and obtain their accurate measurements, he has consulted the astronomer and mathematician. Commencing, as we have seen, with the rudest instruments and measuring apparatus, these, as greater accuracy was required, have gradually been improved, until the present-day appliances and equipment of a surveyor are a wonder of refinement and delicacy.

In order that we may obtain a general idea of what parts of the world have been mapped and what have not, as well as ascertain something of the value of the survey basis for maps of the various parts of the world at the present time, I will now show a map I have recently drawn. It is merely an outline, and diagrammatic in character; but I trust will help to make the matter plain. By way of comparison I have drawn another map showing what was surveyed



870

1860

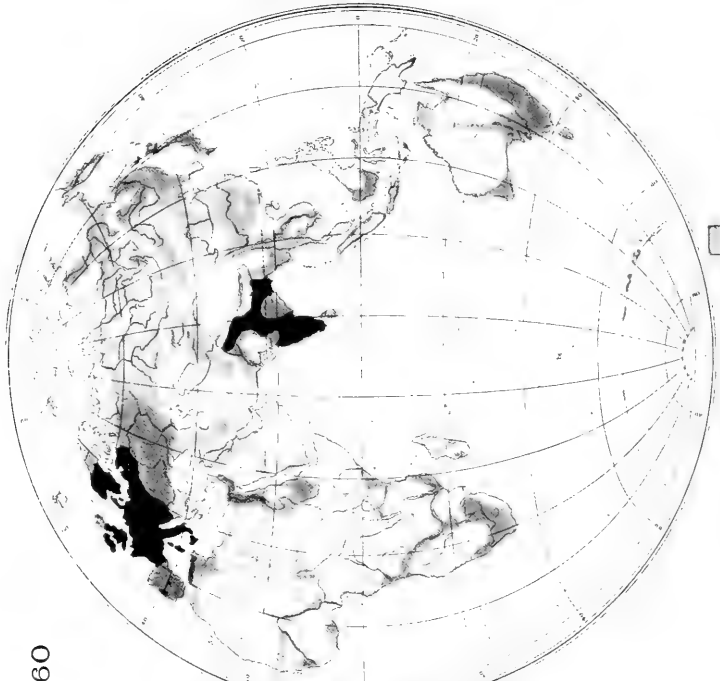

Mapped from Route Traverses and Sketches  
 Entirely Unmapped.....

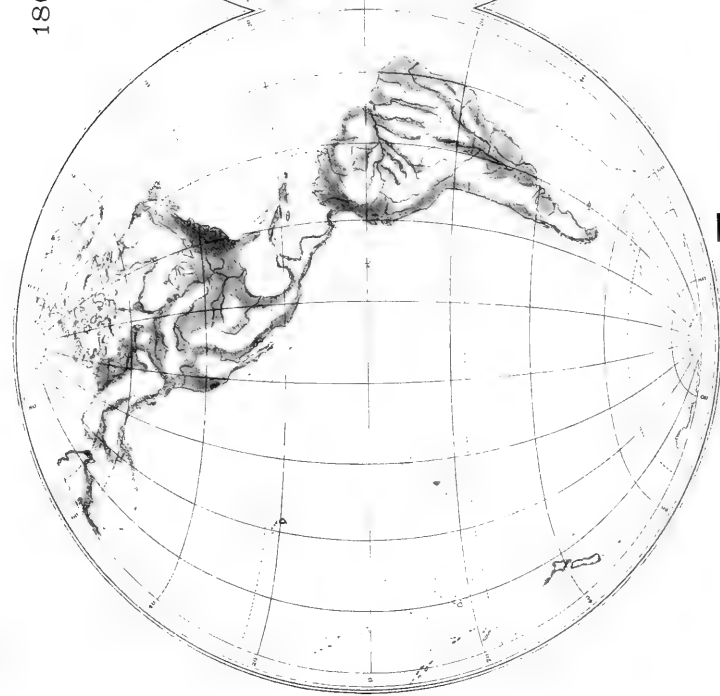

Mapped from accurate Topographical Surveys  
 Mapped from Less Reliable Surveys (chiefly Non-Topographical)

1916

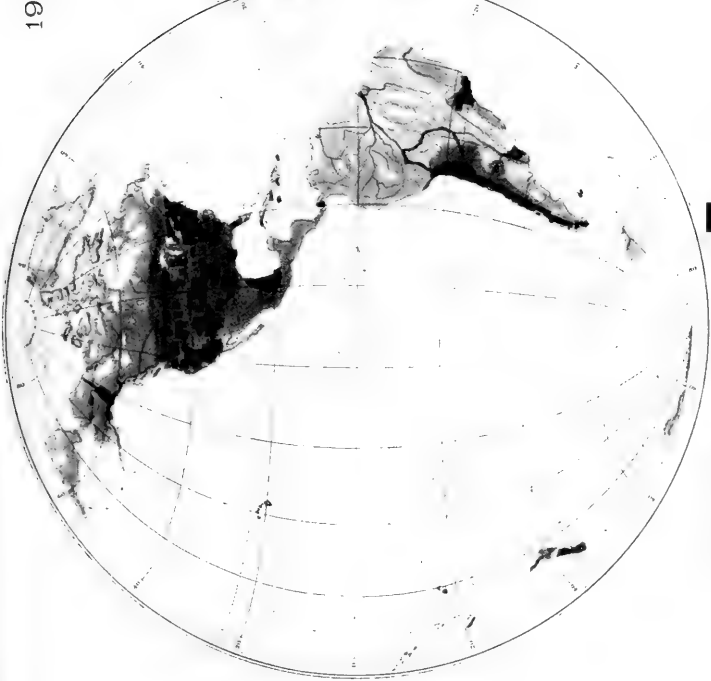

Mapped from accurate Topographical Surveys  
Mapped from Less Reliable Surveys (Chiefly  
Non-Topographical)

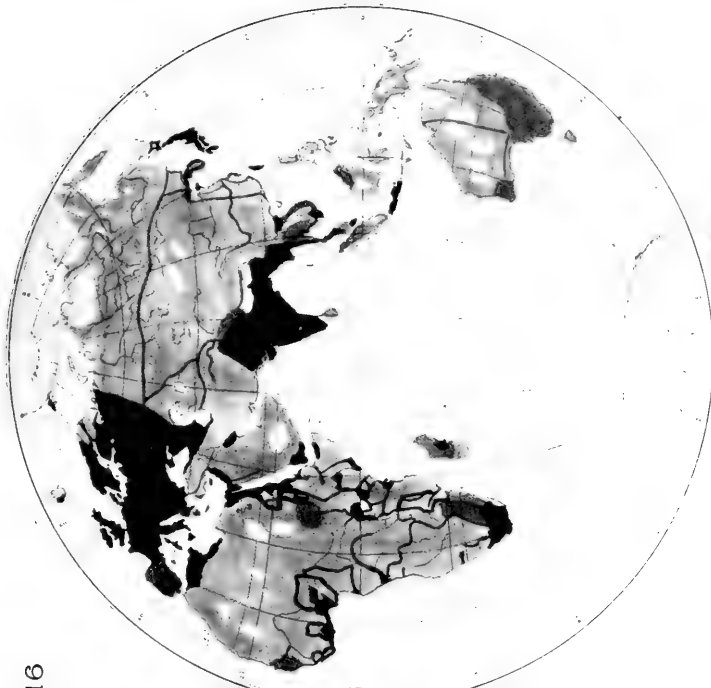

Mapped from Route Traverses and Sketches  
Entirely Unmapped

*Illustrating President's Address—Geographical Section.*



at all accurately, mapped from rough surveys and entirely unsurveyed and unmapped in 1860—that is, nearly sixty years ago. These maps (Plate V.) will, I hope, make the subject clearer to you than if I placed before you mere tables of figures and statistics, which, though important in their place, do not convey to the eye at a glance the facts and proportions that can be furnished by diagrammatic maps and diagrams.

For the sake of comparison of relative areas, the maps are all drawn on an equal area projection, that is to say, a certain area on the map, such as a square inch, everywhere represents the same area on the earth's surface. The idea kept in view in drawing the maps is that the shade deepens as the accuracy of the surveys increases. (1) The parts that are topographically mapped from triangulation or rigorous traverses are shown by the darkest tint; (2) those that are less accurately mapped from surveys chiefly non-topographical, and of which in many places the basis consists to a great extent of disconnected land-office and property plans, are shown by the tint next in density; and then the next lightest tint (3) represents the parts of the world that are only mapped from route-surveys or rough traverses of explorers. Although these traverses vary greatly in degree of accuracy, they cannot be considered so reliable as the surveys shown by either of the other two shades, and in many cases the mapping consists of the roughest sketches. (4) The regions that are entirely unsurveyed and unmapped are indicated by the lightest tint of all, almost white.

Before dealing with the present-day map, I desire to call attention to the 1860 map. Referring to the state of surveys in the Eastern Hemisphere in 1860, it will be seen at once that outside the continent of Europe, where a considerable extent of accurate surveying had been carried out, the only country where any mapping, based upon triangulation, had been done was India. These areas are shown in the darkest shading. In Europe, France, British Isles, Germany, Austria, Italy, Russia, Switzerland, Denmark, the Netherlands, and Scandinavia had already made a good commencement with their Government maps based upon trigonometrical surveys, but these were in several cases by no means complete, and it is interesting to note that even of Scotland there existed at that time no Ordnance Survey for the northern part. The southern part had been surveyed and mapped on the one-inch scale long before this, but the survey was afterwards carried on in England, and, later on, on the six-inch scale in Ireland, so that the northern part of Scotland was not done in 1860. India has been noted for the excellency of its surveys ever since the days of Major Lambton, who started the work in 1804, and Colonel Everest, who succeeded him as head of the surveys after Lambton's death in 1823. As will be seen, in 1860 a considerable extent of India had been mapped from trigonometrical surveys. Even before Lambton's time India had been well ahead of any other country outside Europe with its surveys, which was entirely due to the energy and skill of Major James Rennell, who as Surveyor-General of Bengal surveyed the Ganges and lower Bramaputra rivers, as well as the districts of Bengal, with Behar, between 1763 and 1782.

In the parts of the Eastern Hemisphere that were surveyed and mapped in the second degree of accuracy according to our system, that is, those shown by the next tint, may be included most of the remaining parts of Europe, Egypt, and parts of Algeria near the coast. For the rest such mapping as was done was based upon rough route-sketches, shown by the third tint. In this must be included practically all that was known of the African continent, such as the explorations of Mungo Park, Beke, Livingstone, Speke and Grant, and others, as well as the early exploratory surveys in Central Asia and Australia. The regions that were entirely unsurveyed and unmapped at this time were, as you see, enormous in their extent, and included not only the Polar regions, but vast areas of Central Africa, Asia, and Australia.

Turning to the Western Hemisphere, we find that at this date no triangulation of any extent had been carried out. The U.S. Coast and Geodetic Survey had made a good start, but their work had been confined to the coastline or districts near the coast. There had been La Condamine's attempt at measuring an arc of the meridian near Quito in South America in 1736, the measurement of the Mason and Dixon line, and their survey of the boundary between Pennsylvania and Maryland, in the latter part of the same century; but neither of these

resulted in any serious topographical mapping. Such surveys as existed of the interior parts of the United States in 1860, although they varied as regards their merits and degree of dependence, could not be considered as anything but approximate. Some parts of the eastern States are, as you see, shaded with a tint of the second density, but, with this exception, such mapping as had been done either in North or South America cannot be considered of a higher order than route-traversing and sketching, and is tinted accordingly.

Vast areas of Central Asia, and a still larger portion of the interior of Africa, were entirely unmapped in 1860, as was also the case with South America away from the courses of the great rivers, North America and the Arctic regions. Attempts had been made to penetrate and traverse the desert-like interior of Australia, but to a great extent this region was still entirely unmapped. Several important expeditions had commenced the exploration and mapping of the coast-line of the Antarctic continent, such as that of Captain James Ross, who had penetrated a considerable distance south in the neighbourhood of South Victoria Land, Captain Wilkes and others, who had sighted land to the west of this region. But, after all, little had been done in the way of surveying and mapping in the Antarctic regions.

Referring now to the 1916 map on which the same shades of tints have the same meaning as on the previous map, you will see at once that the parts that are accurately surveyed from a topographical point of view, based upon triangulation or rigorous traverses, have greatly increased in extent, and these now represent, according to a rough estimate I have made, about one-seventh of the total area of the land-surface of the earth, instead of only one-thirtieth, as was the case in 1860. Remarkable progress has also been made with regard to both of the less accurate kinds of surveying and mapping, while the parts that are now entirely unsurveyed and unmapped only amount to about one-seventh instead of a little over one-half, which was roughly the amount in 1860.

I have attempted to form an estimate of the condition of the world's surveys as represented by the differently tinted areas on the maps for 1860 and 1916; and, taking the total area of the land-surface of the earth together with the unknown parts of the Arctic and Antarctic regions which may be either land or water, to be 60,000,000 square miles, I have obtained the following results:—

	1860		1916	
	Sq. Stat. Miles	Proportion to Whole	Sq. Stat. Miles	Proportion to Whole
1. Mapped from accurate topographical surveys based on triangulation or rigorous traverses	1,957,755	= 0·0326 or roughly $\frac{1}{30}$	8,897,238	= 0·1482 or roughly $\frac{1}{7}$
2. Mapped from less reliable surveys, chiefly non-topographical	2,017,641	= 0·0336 or roughly $\frac{1}{30}$	5,178,008	= 0·0866 or just over $\frac{1}{12}$
3. Mapped from route traverses and sketches	25,024,360	= 0·4170 or roughly $\frac{2}{5}$	37,550,552	= 0·6258 or little less than $\frac{2}{3}$
4. Entirely unsurveyed and unmapped	30,997,054	= 0·5166 or just over $\frac{1}{2}$	8,350,794	= 0·1391 or little less than $\frac{1}{7}$

These proportions can perhaps be more clearly seen from the following diagram (Plate II.), on which numbers and tints have the same significance as on the maps and table.

From the figures here given it is plain that with the same rate of progress as that of the past sixty years or so it would take just over four hundred years more to complete the accurate trigonometrical surveying and topographical mapping of the earth's land-surface, including the parts of the Polar regions that may possibly be land—that is, the 60,000,000 square miles which we have taken for this total area; but this will certainly not be the case, since the rate at which such surveys have been carried out has been greatly accelerated during recent years, owing to the rapidly increasing demands for accurate topographical maps, improvements in methods, and other causes, so that it will possibly not

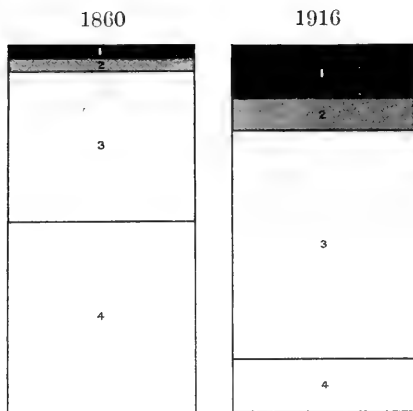





be half this time before all the parts of the earth's surface that are likely to be of any use to man as settlements, or capable of his development, are properly surveyed and mapped. There are, of course, regions, such as those near the Poles and in the arid deserts, that are never likely to be accurately triangulated and mapped to any extent, and it would be mere waste of time and money to attempt anything of the kind.

As might be expected, the parts of the earth's land-surface that are accurately surveyed, about one-seventh of the whole, are those inhabited by the most civilised nations and their dominions. The areas so mapped include the European countries (with the exception of some parts of the Balkan States), India, Japan, Algeria, Tunis, Egypt, and other parts of Africa under the dominion of European nations, United States, parts of Canada and Mexico, the international boundaries between some of the South American countries, and very restricted areas of Australasia. These have all regular Government topographical surveys based on accurate triangulation, and are therefore shown in the darkest shade on the map. The parts that are still unsurveyed and unmapped in any sense are, as will be seen, certain remote unexplored regions near the Poles, a few small patches in Central Asia, much of the interior of Arabia, parts of the Sahara and certain other comparatively small areas in Central Africa, a considerable amount of the interior of South America, specially those parts between the great rivers, and certain areas of the interior of Australia. These are shown by the lightest shade on the map, and at the present day represent slightly less than the area that is accurately mapped. Between these two extremes the surveying and mapping varies in merit and degree of reliability from that of a fairly accurate nature, such as land-office plans (which as a rule make no pretence at showing topographical features) and the more accurate plane-tableing and compass-traversing, which altogether may be taken as covering about one-twelfth of the earth's land area, and that enormously extensive area only roughly mapped from route-traverses of explorers and others, which now constitutes about two-thirds of the whole of the earth's land surface.

Many and varied have been the influences that have led to the surveying and mapping that have already been accomplished, and it would be interesting if we had time to analyse them. Among the preliminary surveys, I think it would be found that military operations would hold an important place. Many an unexplored region has been mapped for the first time as the result of frontier expeditions, such as those of the frontier regions of India and parts of Central and South Africa, while the need of a more exact acquaintance with the topographical features for military requirements have frequently led to more exact trigonometrical surveys. Our own Ordnance Survey is indeed an example of this, for in the first place it resulted from the military operations in Scotland in the latter part of the eighteenth century.

Among other causes that have resulted in surveying and mapping might be mentioned the delimitation of boundaries, commercial or industrial undertakings, such as gold-mining and land-development, projects for new railways, all of which have at times been fruitful in good cartographical results. Nor must we forget Christian missions. The better-trained missionary has always recognised the importance of some sort of a survey of the remote field of his operations, and the route to it, if for no other reason, with a view to the good of his fellow-workers and those who come after him; and in the earlier days specially perhaps most of all pioneer mapping was done by the self-sacrificing service of the missionary. We have only to think of such men as Moffat, Livingstone, Arnot, Grenfell, and others of the same sort, to be reminded of the debt due to the missionary from all interested in geographical mapping.

Still, few of the expeditions referred to so far have had surveying as their primary object, and such mapping as has been carried out has been incidental and necessary for the prosecuting of the main purpose in view. Properly equipped surveying expeditions that have been despatched from this and other countries have during recent times added enormously to our knowledge of the surface configuration of the earth.

The survey of British possessions in Africa and other parts of the world under the Colonial Office have recently made rapid progress, and full particulars

of the work done are given from year to year in the Annual Report of the Colonial Survey Committee, which was first published in 1905. These reports, accompanied by plans and diagrams, contain most valuable information and show exactly what has been done, the method employed, cost of surveys, &c. All who are interested in these matters would be well repaid by a careful perusal of these valuable publications, which only cost a few shillings.

From its very foundation the Royal Geographical Society has had a remarkable influence on the surveying and mapping of the earth's surface, and especially those parts of it which have been previously but very imperfectly known or entirely unexplored. I think it must be admitted that this influence has increased as years have gone by, and it is no exaggeration to say that it has done more in this respect than any other body. It is therefore perhaps fitting that I should give some account of what has been accomplished, as it has a direct bearing on route-surveying and mapping by travellers and explorers. It is not only by the awarding of annual medals to explorers whose journeys have resulted in an increase to our geographical knowledge, and the more accurate surveying and mapping of little-known parts, that the Society has stimulated and encouraged geographical research, but it has also assisted financially numerous expeditions, and the money thus granted has enabled many a man to carry out his explorations to a successful issue, which he otherwise could not have done for the want of funds. Still more frequently has it been the case that travellers going into little-known parts of the world have been granted loans of surveying instruments which they could not otherwise have taken, and encouraged to do what mapping they found possible. Altogether 331 expeditions have been lent instruments, and about 38,500*l.* have been devoted to grants of money by the Society to further geographical exploration and surveying.

There is still another way, by no means the least important, in which the Royal Geographical Society has done much to promote geographical surveying, and that is by providing suitable instruction in the work of surveying for travellers. It is all very well to grant money and lend instruments, but the important thing is to know how to make good use of the money and the instruments so as to take proper advantage of opportunities afforded and to do the best surveys and maps of the regions visited. In the early days of the Society a man had to pick up the requisite knowledge as best he could, but in 1879 a scheme of proper instruction was started at the suggestion of the late Sir Clements Markham, who was then one of our Honorary Secretaries. This had small beginnings, but in recent years has made rapid strides, until at present it forms one of the most important parts of the Society's work. This course of instruction in geographical surveying, which has now been in existence for about thirty-eight years, was first conducted by my predecessor, the late Mr. John Coles, and, since he resigned in 1900, has been under my charge. Altogether 725 surveyors and explorers have received instruction, without reckoning special large classes of forty or fifty men which during the past few years, until the outbreak of war, have been sent to us by the Colonial Office to learn the more elementary parts of compass-traversing and mapping.

Now as regards the future. The demand for properly trained geographical surveyors has been steadily increasing in past years, and is likely to be still greater as time goes on. After the termination of the war there will be much work to be done, especially as regards the surveying of new boundaries, and freshly acquired districts in Africa and elsewhere; and it would be wise to make preparations for this well ahead.

The future surveyor will be in a much better position than his predecessors, not only on account of the improvements in instruments and apparatus for his work, but because, in many parts, a good beginning has been made with the triangulation to which the new surveys can be adjusted. In Asia a considerable amount of new work of this kind has been done over the frontier of India in recent years by the Survey of India, among the more important of which is the connecting of the Indian triangulation with that of Russia by way of the Pamirs. The many boundary surveys that have been carried out in Africa, the triangulations of Egypt, the Sudan, East and South Africa, and other parts of the continent are well advanced, and will be of the utmost value to the future

surveyor. One of the most important lines is the great triangulation which, it is hoped, will some day run across the continent from south to north, from the Cape to Egypt. Owing to the energies of the late Sir David Gill, this important chain of triangles has already got as far as the southern end of Lake Tanganyika; the part to the west of Uganda near Ruwenzori has also been finished, and it now remains to carry the chain through German East Africa and down the Nile Valley. The latter, it is hoped, will by degrees be accomplished by the Soudan and Egyptian Survey Departments, although it may be delayed for some years yet; and the former, which was to have been undertaken by the Germans, it is to be hoped will after the war be accomplished by British surveyors, through—not German East Africa—but newly acquired British territory. Running right through parts of Africa that are but imperfectly mapped in many districts, the stations of this triangulation will be invaluable for the adjustment of any network of triangulation for future surveys in the interior, and, indeed, have already been utilised for the purpose.

The carefully carried out boundary surveys between various countries of South America will be of the greatest assistance in future exploration and survey in the interior of that continent, wherever they are available, while the Survey Departments of Canada and the United States are doing excellent work and extending their surveys far into the imperfectly-mapped regions of North America. So, altogether, the surveyor of the future will soon have a good foundation of reliable points to work from. It is important to remember that running a chain of triangles across a country, though important as a framework, does not constitute a map of the country; and what is wanted, at any rate in the first place, is a series of good topographical maps, based upon triangulation, showing the leading features with sufficient accuracy for the purposes of ordinary mapping, so that on scales of 1 : 250,000, or even 1 : 125,000, there is no appreciable error.

As regards instruments, the Astrolabe à Prisme is being increasingly used for taking equal altitude observations with most excellent results, but at the present time the five-inch transit micrometer theodolite, already referred to, is perhaps all that is required for general work. It has now been thoroughly tested and found most satisfactory. As regards smaller instruments there is the four-inch tangent-micrometer theodolite, and for rapid exploratory survey, where weight is a great consideration, a little three-inch theodolite has been found useful.

For base-line measurement the invar type should be taken on all serious work, and for filling in the topographical features a good plane-table is doubtless the instrument to use. In mountainous regions and in some other special conditions photographic surveying doubtless has a future before it, and in military operations when the photographs are taken from aircraft it has proved itself invaluable; but in ordinary surveying it is, I think, not likely to take the place of well-established methods. The introduction of wireless telegraphy for the determination of longitude is likely to increase in usefulness. Good examples of the work done with it have lately been given in the 'Geographical Journal' and elsewhere.

Time does not permit of my going more fully into this subject, and I must now bring this address to a close.

---

The following Papers were then read :—

1. *France: A Regional Interpretation.* By PROFESSOR H. J. FLEURE, D.Sc.

---

2. *Generalisations in Geography, and more especially in Human Geography.*<sup>1</sup> By G. G. CHISHOLM.

---

3. *The Weddell Sea.* By Dr. W. S. BRUCE.

<sup>1</sup> Published in the *Scottish Geographical Magazine*, vol. xxxii., November 1916.

## THURSDAY, SEPTEMBER 7.

The following business was transacted :—

1. *Discussion on Political Boundaries.* Opened by Colonel Sir T. H. HOLDRICH, K.C.M.G.—See Reports, p. 241.

---

2. *Italy and the Adriatic.* By Miss M. NEWBIGIN.

---

3. *Recent Exploration in the Japanese Alps.* By Rev. WALTER WESTON.

## FRIDAY, SEPTEMBER 8.

Joint Meeting with Section C.—See p. 398.

The following Papers were then read in Section E :—

1. *The Evolution of the Port of Hull.* By Captain RODWELL JONES.

---

2. *Economic Maps.* By G. PHILIP.

---

3. *Annual Variations in Temperature and Salinity of the Waters of the English Channel.* By Dr. E. C. JEE.

---

4. *Periodicity of Sea-surface Temperature in the Atlantic Ocean.*  
By Dr. E. C. JEE.

---

5. *Salonika: Its Geographical Relation to the Interior.*<sup>2</sup>  
By H. C. WOODS.

---

6. *Some Geographical Aspects of a War Indemnity.* By B. C. WALLIS.

<sup>2</sup> Published in the *Scottish Geographical Magazine*, vol. xxxiii., February 1917.

---

## SECTION F.—ECONOMIC SCIENCE AND STATISTICS.

PRESIDENT OF THE SECTION: PROFESSOR A. W. KIRKALDY,  
M.A., B.Litt., M.Com.

-----  
WEDNESDAY, SEPTEMBER 6.

The President delivered the following Address :—

WHEN the British Association held its meeting in Australia in August 1914 the war cloud had only just burst, and thus the distinguished economist who occupied the Presidential Chair of this Section could deal freely with the normal economic problems of old and young communities, disregarding the new and disastrous problems resulting from a great world war. Last year, however, my predecessor was compelled to take account of the critical events of the preceding twelve months. The war which so many presumably well-informed people expected to be over in less than a year is still with us, and the economic difficulties have increased in number and intensity. It is true that one of our statesmen has declared that the war may end sooner than some of us think—a not very hopeful utterance, but still I feel warranted from various signs in dealing in this address rather with the period of reconstruction after the war than with the existing situation, for, owing to kaleidoscopic changes, what is written as to present conditions in August will probably be quite out of date by September, whilst the work of reconstruction may last for the best part of a century, and continue to affect the well-being of the community throughout succeeding history.

*Some Thoughts on Reconstruction after the War.*

We have been at war for two years, and the war has been waged more strenuously than any that human history records. It used to be said that a great European war under modern conditions could not last more than six months; but this prediction, like so many other preconceptions, has been falsified by a world calamity that to the great mass of mankind was entirely unforeseen.

In every sphere this great war has worked, and will yet work, great changes, but in the economic sphere the effects that can already be noted far exceed those in any other.

Up to the present the man in the street will tell you that the war has cost us over 2,000,000,000*l.* In mentioning that sum he probably thinks of sacks of sovereigns, a printing-press feverishly turning out Treasury notes, and the various devices with which he is familiar for making currency or credit. But it would probably sound strange to him to hear that the number of sovereigns in the country is, if anything, greater than when the war commenced, and that currency generally has been enormously increased during the past twenty-four months, for it is not currency that has been consumed. The same man in the street, especially if he live in a munitions district, will discover that there is money in plenty in circulation, that the people all look well-to-do and are living as they seldom or never have before, and he may conclude that war is, after all, not such a bad thing—at any rate, it brings prosperity.

What is the truth? When we say that the war has cost 2,000,000,000*l.* we mean that we have consumed that amount of commodities and services, that

we have diverted capital and labour into new channels of production, but that these channels, unlike those connected with a good scheme of irrigation which may make the wilderness to blossom like the rose, have emptied themselves in the desert and the runnels are now dry and worthless. To put it plainly, the warring Powers have, some entirely, others more or less partially, turned their attention from profitable production, the output of wealth, the exchange or use of which will produce new wealth, to the production of instruments of destruction. When these instruments are utilised they not only consume themselves and leave practically nothing remaining, but they carry out a work of destruction which entails the loss of other accumulations or possibilities of wealth. Nor is the consumption of the instruments and munitions of war the sole or chief material loss to the combatants. The men handling those weapons have to be trained and transported to the field of action, fed during the period of their service, tended when sick or wounded, and clothed and housed in some sort. All these operations consume a quantity of food, clothing, and other materials of various descriptions, and there is absolutely nothing tangible to show for this expenditure.

To take our own case, five million men trained to industry, helping to carry on the business and trade of this country, would consume almost as much food and clothing and other materials as the men in the field and on the sea, but as a return for that consumption there is more than corresponding production of useful commodities, machines, ships, and railway stock, which in turn assist in the work of developing the natural resources of the world or of directly taking part in the work of further production. Thus the position is that for two years we have been consuming our wealth, and to that extent must remain the poorer and be short of many of the goods and services we used to consider necessities of life, until we have, by renewed efforts and a return to the industries and commerce of peace, taken measures to restore those useful things which have been consumed.

When the war ends, it will be incumbent on us all to redouble our activities, increase the productivity of mill, factory, and field; for, so long as there is a deficiency in excess of what we were accustomed to, so long must some of us, and especially the poorer members of the community, feel the pinch occasioned by this devastating war.

But, it may be asked, how are we to increase our productivity? The war, in spite of the suffering and loss occasioned, has not been all loss. As a nation—nay, as an Empire—we have found ourselves; but this thought, if developed, would lead us into spheres foreign to the work of this Section. We have taken measures which must result in improving the physique of our race. Of the many thousands of men who have been trained to arms and submitted to discipline the great majority happily will return when peace is made. The self-sacrifice practised by these men will act as a leaven among our population—it has already done so. We shall emerge from this war a better-disciplined, a more serious people, better equipped mentally and physically to cope with new conditions. We have learned what hitherto had only been suspected or at most known to a few, that we have not produced anything like our industrial maximum.

An insidious element of friction threatening to develop into class war has been sapping our energies. There have been faults on both sides, but daylight is being thrown over the situation, and the waste and loss of this friction have been laid bare. If we do not take to heart this great experience and alter our ways for the better, then we deserve to go down as a nation; but I am persuaded that the lesson is being learned, that the picture now visible of industrial waste and loss—a loss that falls most hardly on the masses of the people—will not pass before our eyes unheeded.

Not only was there loss through friction between employers and employed, but in many industries we were continuing to use out-of-date tools and methods long after they should have been discarded. A long era of prosperity had not, indeed, caused decadence, but was threatening to do so. The war has shaken us up and shown us the realities of life, making the mistakes of the material side with which we have to do here plain and unmistakable.

To beat the national enemy we had to re-equip our workshops, and the new equipment will be available to a great extent for future work. Moreover, we

have been taught by a bitter lesson that up-to-date equipment is as necessary, if we are to maintain our position as an industrial and commercial nation, as it was to enable us to maintain our international position.

Friction between employers and workpeople led to restrictions on output, indifference led to utilising old tools and methods; both meant decrease of productivity. The necessary increase can be readily obtained by remodelling our system in these respects. How this can be carried out so far as reorganisation of the industrial forces of this country is concerned will be developed later, and is dealt with in greater detail in the Report presented by a Committee of investigation which has been working for this Association.

*Attempted Forecast of our Industrial Future.*

I want to attempt now to make a forecast of what may be expected in the commercial and industrial spheres when we sheathe the sword. Germany has overrun some important manufacturing districts. Belgium, North-Western France, and Poland have not only been occupied by the enemy, but machinery and industrial equipment have in many cases been removed to Germany. It is reported that railway tracks have been torn up in order that their materials might be used for military purposes elsewhere. The busy industrial areas mentioned have undoubtedly suffered very considerably, and will require to reconstruct and re-equip towns and factories, and to reorganise the labour-force. To set commerce and industry at work again on anything like the previous scale must be a work of some time. On the other hand, in spite of every effort, Germany has found it impossible to interfere with the industries of the United Kingdom either by force or intrigue; nor have the Entente Powers as yet invaded Germany. Indeed, for the purpose of this forecast it is wise to assume that German industrial equipment will not be affected detrimentally by the war. Even though we should invade Germany with a view to inflicting, not only defeat, but punishment, our purpose will not include industrial destruction. We shall undoubtedly do our utmost to punish those, whatever their rank, who have been responsible for the many crimes committed against humanity during the past two years. But this does not necessitate the ruthless destruction of mill, factory, or mine. We can quite adequately punish Germany without putting ourselves on a par with her in methods of destruction and brutality. The military caste must be summarily punished and the entire nation must be made to realise the sentiments of horror that their delight in the sinking of the *Lusitania*, the executions of Miss Cavell and Captain Fryatt, have aroused throughout the world. Every instance of insensate brutality must be atoned for by the guilty parties, and the nation as a whole must be taught such a lesson as shall make a repetition of those savage methods impossible. We feel our ability to carry through this salutary work, but when this is effected and when once again the world begins to get into its normal stride, so far as one can foresee, England and Germany will for some time be the only two European nations prepared to take any considerable part in international trade.

Meantime during the period of the war, two countries—the United States of America and Japan—have enjoyed new and unlooked-for trading advantages. So far as competition from the United States is concerned, it is probable that we need not feel unnecessarily pessimistic. The South American States are at the beginning of a period of development which may well prove to be rapid. The possibilities opened up by the Panama Canal route, even though the present canal should prove a failure, will not be resigned before another attempt is made to pierce the isthmus; that a cutting will eventually be made is in my opinion beyond question. American developments, then, may be expected to take place principally on the American continent, in the Pacific, and in the Far East. In these regions there is ample room for both British and American enterprise.

Nor will Japan, for some time to come at any rate, compete with our staple manufactures.

The development made by Japan during the war would seem to indicate that it is Germany, and not Great Britain, that will have to bear the brunt of Japanese competition. Small goods and fancy articles which came freely into our markets from Germany and Austria before the war are now being made in Japan. Our merchants, being unable to get supplies of these goods, sent

samples to Japan, with the most satisfactory results as to price, finish, and quality. Thus we have been able to extend our business relations with our ally at the expense of our enemy. Moreover, although there is no certain information on the subject, it is more than possible that when normal trading is resumed it will be found that Japan has been extending her business in these and other classes of goods into other markets hitherto the preserve of the Central Powers.

Hence it is of special interest to attempt to forecast to what extent and with what prospects England and Germany will be in competition in international trade after the war. This will depend for the most part on two sets of factors: (i) the internal industrial condition of each country and (ii) commercial factors. So far as the former are concerned, there is much that this country should realise and take to heart.

The United Kingdom, in spite of the war and its heavy drain on our resources, has been enjoying an exceptional time of seeming prosperity. A large section of the workpeople have been earning high wages, whilst some employers have been earning handsome profits. High prices, high wages, high profits have been the order of the day. The return of peace will very considerably modify the last two of these, and how will those affected face the change?

To understand how the parties will answer this question, certain agreements must be remembered. Foremost among these is the State guarantee that certain Trade Union restrictions and Government regulations which have been in abeyance for the period of the war shall be reimposed when peace is restored. If we were reverting to pre-war conditions there would be much to be said for this, but one hopes that both parties realise fully that conditions have radically changed, and that in consequence both employers and workpeople must be prepared to meet the new situation in a new spirit. Why were these agreements and regulations set aside? Because it was known that they hampered output, and our military success depended upon our producing the greatest possible amount of munitions of war. Our commercial success will now equally depend on getting the utmost possible production out of our industrial equipment. Are we then going to restore these obstacles just at the most critical moment?

With the return to more normal times the national necessity for war stores and munitions will cease, and our industrial forces will have to rely on the home and foreign markets for employment. Foreign competition will almost certainly be greatly intensified. There may be at first a great demand for manufactured goods of all kinds, as a consequence of decreased supplies during the war, but all the principal trading nations will strain every nerve to get the greatest possible share of orders. If, under such circumstances, we indulge in an internal struggle between Capital and Labour, instead of bending our whole energies to retain and extend our hold on markets, we shall lose an opportunity which is not likely to return. And yet there is a widespread expectation among employers and workpeople that the European war will be succeeded by serious industrial strife.

So far as the commercial factors are concerned we have almost everything in our favour. We have not outraged the sentiments of humanity by employing inhuman methods in waging war. We have retained our position as the headquarters of the money market. We have our shipping resources and equipment practically intact. Our merchants and exporters are keen and ready to carry on their business with even greater energy than before the war. We have arrears to make up, but have the will, and, with harmony at home, the ability to carry on a more extended trade. Our capital has not been seriously affected, and there are no signs that it will be—our financial establishments and banks are prepared to do their share.

Turning to Germany, there is a most interesting condition of affairs to study. If beaten in the war Germany will be a poor country; the economic position will be deplorable, but hardly irreparable. Every section of the community has already felt to some degree the effects of the war. When peace comes there will be a determined attempt to regain the old position. A disciplined people, acting under a Government that will be compelled by circumstances to foster every possible means for repairing the broken machine



of trade and for restoring the national wealth, will without any doubt be prepared to make heavy sacrifices to regain what has been lost. The Government will offer advantages in the shape of low railway rates and canal facilities, and, as far as possible, bounties on export business and on shipping to encourage and extend foreign trade. Manufacturers and merchants will cut down profits, and workpeople will be carefully taught that only by increased productivity and by a period of low wages can that which has been lost be regained. One foresees a remarkable attempt by a united and determined nation to make good in as short a period as possible the waste and loss occasioned by the war and the blockade. German goods for export will be cheap, and the low price will be still further emphasised by the depreciation of the mark. For so long as the mark is at a discount there will be a *pro tanto* advantage to export trade, and although the mark may eventually regain its par value, a few months or even weeks will have an appreciable influence on reopening foreign business.

Thus a comparison of English and German possibilities in foreign trade on the resumption of peace shows that there are certain advantages on both sides. The German advantages are solid and appreciable, but if England is seething with industrial friction the advantages she possesses will be neutralised and her failure a certainty.

This leads us to consider whether a policy can be devised which will remove causes of friction and assure to our industries a new era of prosperity.

#### *The Need for National Organisation.*

It is at first sight curious, but still very natural, that Press and public should from time to time be obsessed with one idea. As the war developed there has been a growing tendency to demand Organisation in every sphere of national life. The striking successes scored by Germany have been universally, and probably rightly, ascribed to thoroughness of organisation and complete preparedness before provoking the conflict. As a consequence, a comparison has been made between English and German military policy, greatly to the detriment of the former. And, not content with this, further comparisons have been made, with the result that, if one believed all that was printed in the newspapers or accepted what passes in private conversation, we should be led to believe that rule of thumb has been the leading British characteristic. It has been forgotten that Germany has for many decades prided herself on her Army, even as England has relied on her Navy. One has been a great military power; the other equally great at sea. The test of war has proved that Germany was a very difficult country to oppose by land, but that in naval matters England is supreme. The economist, however, has to go further and investigate into those matters which are connected with his science—namely, the production, the distribution, and the consumption of wealth. Can it be said that the want of organisation and other faults of our military system are typical of what has been going on in the industrial and commercial sphere? I for one cannot bring myself to accept the truth of this. Had our economic interests been carried on under so-called War Office principles we could not have built up the great position we occupy as world traders. What, then, are the facts? To answer this question one should remember the leading facts connected with our industrial development. This brings out some points which the superficial observer inevitably misses. For upwards of a century our industries have been gradually developing, and the progress has on the whole been along healthy lines—each decade has seen some advance more or less great.

German attention to industry and commerce is much more recent. She was able to benefit by our experience, nor was she slow in doing so. To take a simple illustration. A manufacturing firm of fifty years' standing has developed a system and has equipped factory and workshop as occasion demanded. A rival, seeing the possibility of competing successfully in the same business, organises a new company, raises the necessary capital, and is able to commence operations with plant, machinery, and equipment of all kinds absolutely up to date, and even with some new improvements. In these circumstances, provided that the management be good and that there is a demand for the goods produced, the new firm has on the manufacturing side considerable advantages. The older

firm, however, is not devoid of advantages. It has a certain connection, a goodwill, and with able management these will enable it to compete with the newcomer, whilst the managers will have time to consider how to put the manufacturing side of their business on a par with that of the rival firm. The position in a simple instance like this is fairly easy to understand. In the case of a nation, with its many and varied interests, it takes a very much longer time for the situation to develop. The agitation for Tariff Reform and Colonial Preferences is a proof that several years before the war broke out some Englishmen were awake to the fact that a new condition had come into existence, and that, if we were to preserve our advantageous position, we must take careful stock of newly-arisen factors in world-trade. For Germany was not the only one, nor perhaps the most serious, of these factors. The United States of America, from the time of the Civil War, had bent her energies to the work of internal development. Having concentrated on this for nearly forty years, she began to expand a world-policy both political and commercial. Japan, too, emerged with unexpected suddenness into the arena. Thus, as the nineteenth century drew to a close, the economic interests of England required careful and earnest attention. The fiscal controversy undoubtedly had the great and important effect of waking English traders out of the lotus-eating condition into which they were in danger of sinking. All our principal and many of our less important industries were carefully reviewed, with results that can be realised by a study of the annual statistics published by the Board of Trade. There was, however, a very subtle policy being pursued, which required very minute knowledge and wide experience to grasp. It was our proud boast that we left trade free and untrammelled, that we believed in the health-giving effects of open competition. It needed the stern lesson of the war to make known how this generous policy could be utilised to our detriment by a rival commercial nation. The facts as to the exploiting of the mineral resources of the Empire, as to how the dye and colour industry and various by-product industries have been developed so that certain vital trades almost passed under foreign control, came to light only just in time.

It became plain, as these facts leaked out, that we needed a better system of industrial and commercial intelligence. There was also a lack of unity of working among our principal industries incompatible with the growing interdependence which has been a marked feature of modern economic life.

Hitherto, apparently, it has been no one's business to survey comprehensively the resources whence our raw materials are drawn. Even those resources within the Empire have been nervelessly left to be exploited by the first comer, and the mask of an English name has enabled foreign capital and energy to divert some of our valuable minerals to foreign countries, whence we have been compelled to purchase them at unnaturally enhanced prices. Sufficient of the facts have been made public to warrant the demand for reconstruction and improved organisation of those departments responsible for the national trade.

It would be most unwise as well as ungenerous to attempt to blame our Board of Trade. That department has, on the whole, worked hard and well for British interests. But it is both wise and necessary to criticise the policy that has overweighted this one Government department. And although there should be very careful consideration before either recommending or making a drastic change, attention ought to be given to the frequently expressed opinions of both Chambers of Commerce and individual traders in favour of the creation of a Ministry of Commerce. To this Ministry there might be transferred some of the functions of the Board of Trade, whilst at the same time the new Ministry might be responsible for maintaining that general survey over trade and commerce without which any organisation we may attempt would be incomplete.

If this view be accepted, it is not fair to charge our industrial interest with lack of organisation. An examination of any one of our industries—ship-building, shipping, the manufacture of various goods for export—shows that each has been well, and in many cases exceptionally well, organised; but the organisation requires to be completed by some machinery with responsible officials to co-ordinate the organisation of the several interests. Even in this direction something has been attempted. The Associated Chambers of Com-

merce give, at any rate, the germ of an organisation for attending to this great need. We may ask whether this could be still further elaborated so as to give the country what is wanted. Have our Chambers of Commerce sufficient standing to make their association strong enough for the work; or should we look to the State to supply the keystone to the arch? The answer to this will depend on the views of the individual attempting to give it. Perhaps the time has come when a word of warning should be uttered. Are we not getting rather too prone to fall back upon the State? We were, and perhaps still are, the most self-dependent people in existence. Both the employer and the Trade Union have in the past been but little inclined to turn to the State. Can the completion of our industrial and commercial organisation be adequately attained by the interests concerned, or must we look to another State department or sub-department to effect what is required? Our past history seems to suggest that before turning to the State we try the initiative of the interests at stake. This brings us to a further section of the subject.

#### *Industrial Organisation.*

The organisation that has grown up with the development of our industries includes two very important but unequally developed sets of organisation. The Industrial Army of Labour force of this country includes all those who either organise industry or take any part, however important or however humble, in its working. From the captain of industry, or *entrepreneur* as our brave allies call him, down to the humblest weekly wage-earner, we have a labour force which ought to be looked upon as one and indivisible. In connection with this force we now have two sets of organisations whose interests some people consider to be antagonistic. I would emphasise the fact that these two are really one force, their main interests are identical, and they can best serve those interests by striving to minimise differences and by doing all that is possible to work in harmony.

Though theoretically one, the labour force has internally developed two sets of organisations. Manual labour has its Trade Unions; the organisers of industry have their Associations; British Trade Unions have a fairly long history behind them, and may be said to be in advance of any similar unions the world over. But the fact that of recent years there has been a tendency for small unofficial sections of given unions to kick over the traces and disregard the policy and agreements of their leaders shows that perfection of organisation has by no means been attained.

Employers' Associations are of more recent formation, nor have they so far attained to anything like the same completeness. Both organisations, especially the employers', are in need of further development. It is hardly for the economist to show how this can be effected. He can point to imperfections and make suggestions—only those conversant with practical working facts can formulate a practical policy. The most patent defects of these associations are due to the very virtues of their members. The individual British business man is unexcelled by the business man of any other country. In times of rapid transition and crisis he has again and again shown his leadership. He knows his business thoroughly, and as a working unit he has taken a very high place. But one of the most marked developments of modern trade is a growing interdependence of industries. Hand in hand with this we have become familiar with another phenomenon, the amalgamation of businesses of various dimensions into one great company or corporation. This phenomenon is common to both commercial and manufacturing interests. It is as marked among banks as among steel and iron companies. The comparatively small manufacturer or business man is giving place to bigger and inclusive organisations. These two and somewhat parallel developments are making a new demand on the individual. He and his predecessors exemplified individualism; the new stage upon which we have entered demands a modification of the old policy. Business, like everything else, is subject to evolution, and evolution on healthy lines can only be obtained by grasping fundamental facts and applying experience in accordance with economic laws. There need be nothing revolutionary about the required changes in our business organisation. We merely have to note what has already occurred, mark healthy tendencies, and clear away or prevent obstructions to natural growth. Our past history amply justifies us in pursuing

this policy without uncertainty as to the result. Our entire industrial history is one of the best examples of steady and on the whole well-ordered evolution. We have shown our ability to adapt ourselves to the needs of the moment. As a race we are healthily conservative without being reactionary. That is to say, we know how to preserve what is good in the old and amalgamate it with the new. In other words, our organisation enjoys that useful quality of elasticity which enables us to keep abreast of the times.

Bearing this in mind, where are the defects of our business man, and to what does he need to give attention in order to come into line with the most recent requirements?

As I have just said, our business man's qualities emphasise his defects. For generations our business men have worked as units, and individualism has become almost second nature. The call now is that the individual shall sink a part of his personality and become, so far as one side of his activities is concerned, a member of an association. We have had Employers' Alliances, Federations, and Associations. Some have failed, some have managed to keep afloat, others have had a certain amount of success. None have hitherto quite attained to what is required. To the onlooker it would appear that when our employers meet as an association there is a lack of sympathy among the members, and if this should persist it would be fatal. Each individual knows his own business; he does not know, and perhaps it would be true to say he does not care to know, his neighbour's concerns. At any rate, as a result there is a lack of cohesion; there is a lack, too, of that co-operation which is required if the association is to be really successful and accomplish the objects for which it has been formed. This working in co-operation, the large organisations of capital, and the working together in associations, are comparatively new things to our business community. Time and experience will put things right; at present we have not accustomed ourselves to a newly-developing condition of affairs. Our business men, then, need to focus their attention on these early ailments of the movement and get them removed as soon as possible.

A second group of defects arises indirectly but almost inevitably from that which has just been considered. Some alliances, rings, and associations have failed and come to an end. And in certain cases the cause has been unmistakable, for there has been a lamentable want of loyalty, and even in some cases it must be said honesty, to the agreements entered into by the association.

Only to mention one group as an instance of this—the New Trades Combination Movement, which caused quite a considerable stir during the late 'nineties of last century, especially in the Midlands among the metal trades. Articles appeared in the journals, and a book<sup>1</sup> was written explaining the movement and great hopes were entertained that a new era had opened out before both Capital and Labour. But all ended in a failure. There was for a time a kind of Syndicalism—a syndicated industry enabling employers to increase their profits, and the workpeople to earn abnormally high wages. So long as competition could be kept out of the market, things went swimmingly and a specious prosperity developed. But the consumer was being exploited—the increased prices charged for such goods as metal bedsteads gave would-be competitors and unscrupulous members of the alliance their chance. The cheap wooden bedstead, however, made its appearance on the one hand, and on the other there were such things as secret discounts and commissions, and this special alliance ended in failure. The history of that short, but industrially instructive, movement has yet to be written. Its cardinal facts should be known to those who now have an opportunity for shaping the industrial future of this country.

Three lessons stand out from this experience :—

- (i) We must learn to work together in association.
- (ii) All members of an association must be absolutely loyal and honest to their engagements, either written or implied.
- (iii) Such associations must be regulated or the community will be exploited.

Nor is it impossible to suggest a method by means of which this may result. When Employers' Associations have justified themselves it should be possible to obtain State recognition for them, and it would be practical politics, when both

<sup>1</sup> *The New Trades' Combination Movement*. E. J. Smith. Rivingtons. 1899.

Employers' Associations and Trade Unions have developed to the point at which both merit State recognition, to enforce under penalty agreements made between them on all those, either employers or workpeople, who wished to work at the industry within the area under the recognised organisations. Thus it would not be necessary to make membership compulsory; self-interest would be the extent of the pressure.

Turning to workpeople's unions we also find defects which require removing. The policy of union has been practised among the workers for upwards of a century, and for at least half that time with well-marked success in certain directions. In the first instance it was the aristocracy of labour that realised the advantage of collective action, but, notably since the late 'eighties of last century, efforts have been made to extend the policy to all grades of labour. Hence the ailments which have to be noted are rather more mature than those affecting Employers' Associations. Success in certain directions has perhaps led some of the more ardent spirits to expect more from their unions than working conditions allow. The experience of old and tried leaders has led them to adopt a more cautious policy than the young bloods are inclined to accept. Hence there has been a want of loyalty, different, it is true, from that met with among employers, but equally disastrous if persisted in to the object in view.

All the men in a given industry should be members of the union, provided that the union is well organised and ably administered. This should, however, be the result of self-interest and a regard for the good of fellow-workers, rather than of compulsion; how that may be attained has been suggested. Perfection of organisation will come when workpeople not only realise the real possibilities of collective action, but are prepared to follow loyally leaders who have been constitutionally elected. The leaders are in a better position to know the facts of the case immediately under review, but if their leadership has been found faulty there should be adequate machinery for replacing them with men who command the confidence of the majority of the members. When agreements have been entered into, the terms should be implicitly observed, even though they may turn out to be less advantageous than was expected. Periodical revision would make it possible to rectify mistakes or misapprehensions. But it cannot be too strongly emphasised that for both sets of organisations the great factor making for smooth and satisfactory working is absolute loyalty to the pledged word. A large employer of skilled labour, writing to me on this point, said: 'In my opinion no industrial harmony can exist between employers and employees until Trade Unions, through their Executives, can compel their members to adhere to and honourably carry out all agreements entered into with the employers. . . . In fact, until a more honest code of morals exists on both sides no improvement can be looked for.'

Further, there is a need for a more complete and authoritative central authority, both for individual industries and for federated trades. The machinery for this exists; it merely requires development. When the local and central machinery has been perfected, the right to *strike*, which, in common with the right to *lock out* as a final resource, should be jealously maintained, would be carefully regulated, and would only be resorted to as the considered judgment of the most experienced men on either side. It should be impossible for either an individual association or a section of it to order a strike or a lock-out on its own responsibility.

What, then, do I consider should be the main outline of industrial organisation? Employers should be organised into:—

- (a) Associations of one trade in a given district.
- (b) National Associations of one trade.
- (c) Local Federations of trades.
- (d) National Federations of trades.

Of these, *b* and *d* should be organised under a system of representation.

Workpeople should have unions and federations corresponding to those of the employers, and in both cases the National Federations should be carefully organised Councils who would enjoy a large measure of authority, tempered by the necessity to win and preserve the confidence of their electors. From these two representative bodies there could be elected an Industrial Council as a Court of Appeal, representative of the whole industrial activity of the country, and so

far as these various bodies were approved by the State they would enjoy far-reaching powers.

Approval by the State should depend on the observance of moderation and working in conformity with carefully devised regulations. For the State in this matter would be the representative of the consumer and of the national interest. Without this you get something not very far removed from Syndicalism, but under careful regulation abuses might be avoided.

At the head of the organisation there would be a real Industrial Council representing the industry of the country. The Industrial Council established in the year 1911 has never had a fair chance to show its mettle. It was established at a critical time; perhaps the Government did not feel justified to throw a great responsibility on an untried body. Nevertheless it exemplified a very wise policy, and one regrets that it has not been tested, for even now both employers and workpeople feel that some such Council is preferable to State interference, and there is a clearly articulated distrust on both sides of official arbitration.

We do not need at the present juncture to attempt a new experiment. Our old system, whatever its failings, has been tried and proved sound. Its elasticity has been its salvation, and it is capable of still further evolution without calling for drastic changes. The improved organisation that is now suggested would contain nothing that is new or untried. It would consist of natural developments of what already exists. Employers and workpeople have organised themselves into associations and unions, some of these have developed federations of similar or even of unconnected interests; and both parties have their national congresses, or at any rate the germ of them. The demand now is that the organisations already in existence be perfected, and that those perfected organisations shall in all their agreements be loyally and honestly supported by their members. Success depends on absolute loyalty to the pledged word.

Here we have a practical policy suited to the needs of this critical stage in our history. The ideal organisation has yet to be formulated, but what is here proposed would form a definite step in advance, and the very elasticity of the system would be a good augury for the future.

Among the innovations recently introduced into this country, and one calculated to have important effects on our industrial well-being, is automatic and semi-automatic machinery. We have been accustomed to the use of labour-saving machines—indeed, this country was the birthplace of many of them. The re-equipment, however, of our factories for war purposes, both in tools and workpeople, has wrought a revolution comparable with that effected by the introduction of the steam-engine.

From the point of view of craftsmanship our old system had much in its favour. Our mechanics in certain trades had to be highly skilled, for the description of work turned out made considerable demands on the operative. In America and Germany standardisation has been carried very much further than in this country, and consequently repetition work was much more generally practised than with us.

One may grieve over the passing of our old methods, as one is sometimes tempted to regret the days of cottage industries. Neither, however, is compatible with modern conditions, and an important part of the work of reconstruction and reorganisation will be connected with standardisation and the further introduction of repetition work. This will call for the exercise of careful and experienced industrial statesmanship, if trouble is to be avoided, for agreements will have to be framed which will in the long run work equitably and satisfactorily to all the parties concerned.

A Committee of this Association has been investigating for the past two years into the extent to which women have recently replaced men in industry. A certain amount of exaggeration exists as to the number of women who have entered our factories or undertaken services left vacant by men who have joined the Forces. The total number is in round figures about 600,000, as against five million men who have joined either the Navy or the Army as a consequence of the war.

The entry of large numbers of women into industry has been viewed with a certain amount of alarm by the men; and Trade Unions have naturally stipulated, where possible, that these women shall receive the same rates of pay

for the same work as the men, and that when the men return the women shall give place to them.

That there was little ground for alarm as to the influx of women can be realised by a consideration of a few facts and figures. The majority of men who enlisted were workpeople of one sort or another; of these, unhappily, some have been killed in battle or have been rendered incapable for work. Even so, the majority will come home requiring occupation. What opportunities will they find?

To answer this question at all satisfactorily it is necessary to consider some determining factors. Thousands of men have left indoor occupations and their accustomed town life, and have been trained, drilled, and disciplined under open-air conditions. They have lived, worked, and fought in the open country in some cases for many months. The new experience has had potent effects. Physique has improved, the outlook on life has changed, in many cases new hopes for the future have been formed. Inquiry shows that there is a division of opinion as to the extent to which disbanded members of the Forces will decide on making a radical change in their mode of life. Yet the experience of what occurred after the South African War warrants us in assuming that considerable numbers will only return to indoor occupations and town life if there be no alternative. It is too soon yet to form an opinion as to what opportunities there will be for land settlement. But it is known that offers will be made both at home and in various parts of the Empire. A moderate estimate of those accepting these offers, and of our losses of killed and permanently disabled, would be at least one million. Then we shall undoubtedly require, at any rate for some years, a much larger standing Army. Even on a peace footing this at a moderate computation may be put at a million men. These two figures, and neither of them errs on the side of exaggeration, will absorb two million men who will be permanently lost to the old occupations.

Moreover, there is good ground for anticipating that if the war concludes before our resources are unduly strained, and there is every prospect that it will, there will be a period of good trade. We have to restore our own depleted stocks of goods, our mercantile marine demands a large amount of new tonnage, railways and other transport services will require much new equipment. Turning to the Continent, parts of France, Belgium, and other of the Entente countries will need reconstruction works of considerable proportions, and in this work we shall play a great part. World markets, too, have been kept short of many manufactured goods. We shall be in a position both to finance and carry on a greatly extended system of industry and commerce, for not only is our banking system prepared to face this, but our man force has been greatly improved, and our industrial equipment to a great extent remodelled.

Reverting to the somewhat thorny question of the women who have been engaged on what were men's occupations, I see no cause for alarm. Many women came forward from motives of patriotism and will gladly resume their former state. The question, I believe, will rather be, how can we obtain the labour necessary to cope with the post-war demand?

The new equipment of our factories will place us in a position to increase very greatly our output, and this should enable us not only to face a possible labour shortage, but, if the recommendations made by this Section of the Association meet with a favourable response, our labour force should enter upon a new period of prosperity consequent on a remodelling which has been rendered possible by a reorganisation of our industrial machinery. This new epoch for labour would include higher wages, shorter hours, and better working conditions. To effect these salutary advances both employers and employed need to exercise sanity of judgment, frankness in mutual discussions, and a recognition of the fact that the prosperity and material well-being of each is bound up in a common effort to maintain and develop our industrial and commercial position.

---

The following Report was then presented and discussed:—

*On Industrial Unrest.*—See Reports, p. 274.

---

## THURSDAY, SEPTEMBER 7.

The following Report and Paper were received :—

1. *Outlets for Labour on the Land.* By CHRISTOPHER TURNOR.

---

  2. *Report on the Replacement of Men by Women in Industry.*  
See Reports, p. 276.
- 

## FRIDAY, SEPTEMBER 8.

The following Report and Paper were received :—

1. *Report on the Effects of the War on Credit, Currency, and Finance.*—See Reports, p. 278.

---

2. *The English Historical Method in Economics.*—Rent.  
By T. B. BROWNING.

1. This paper opened with two questions: (1) Has the war introduced any substantial change in the nation's attitude towards economic problems? And (2), if so, is it likely to be permanent and induce a corresponding change in national policy? Answering both questions in the affirmative, the writer selected for consideration the subject of rent, because the main schools of economic thought, both at home and abroad, diverge at that point.

2. Then followed the body of the article, dealing, first, with the founder of economic induction in England, Dr. Richard Jones (1790–1855); secondly, with his classification of rents, his summation of their incidents, and inferences from the facts ascertained; and, thirdly, with later developments of the inquiry in respect to proprietorship and tenancy, redemption of the soil, and the relation of price to rent and wages.

3. The view thus obtained is contrasted with the deductive or speculative conception usually associated with the name of Ricardo; with the outcome of that conception as applied to India and as embodied in current doctrines of increment, State-assumption of rent, and theoretic Socialism; its adaptability to statistical and social investigation respecting the individual, the family, the State; and its relation to the prime elements of national welfare, consumption and production, price of goods, and value of industries.

4. In conclusion the author expressed the conviction that a similar success would accompany and follow a more intense application of the comparative method to political economy as has signalised its application to philology, law, and the several branches of sociology.

---

## SATURDAY, SEPTEMBER 9.

The following Paper and Report were received :—

1. *The Decimal System in Currency, Weights, and Measures.*  
By Sir RICHARD BURBIDGE and Dr. G. B. HUNTER.

It is of vital importance to prepare for the necessary reform in British weights, measures, and coinage now, in order that at the end of the war we shall be able to start on equal terms with our trade adversaries. An immense competition for the trade of neutral countries is coming, and orders will



naturally be placed with countries which use the weights and measures to which they are accustomed. There is every reason to suppose that the United States realises this, and already a Bill has been introduced into Congress which will make the metric system the only legal one from July 1, 1920.

France would welcome this change being made by Britain, which would undoubtedly make trade conditions easier between the two countries.

Italy expresses the same opinion. But, while preferring to buy British goods, German and Austrian merchandise (not handicapped by complicated weights, measures, and coinage) are flooding and being purchased in that country.

Similar reports come from the French Riviera.

The Consul-General of Bolivia strongly advocates the use by Britain of the metric system as an aid to recovering her trade with South America.

The *Buenos Ayres Standard* gives figures contrasting the amount of machinery supplied by Germany and by Britain to Argentina before the war.

The Overseas Dominions are prepared to make the reform, but are waiting for the Mother Country to move first.

The advantages to be gained at home by the reform comprise great saving of time educationally, and also a saving of time and labour in industrial and commercial undertakings of every description.

- 
2. *Second Interim Report on Fatigue from the Economic Standpoint.*  
See Reports, p. 251.
-

## SECTION G.—ENGINEERING.

PRESIDENT OF THE SECTION: GERALD G. STONEY, B.A., F.R.S.

---

WEDNESDAY, SEPTEMBER 6.

The President delivered the following Address :—

At times such as these the mind naturally turns to problems to be considered both at the present time and after the war, and in considering such problems a review of some of the errors committed in the past is most necessary.

Such a review enables methods which should be adopted both now and in the future to be considered.

As this is an address to the Engineering Section of the British Association for the Advancement of Science, only such problems will be considered as affect engineering and its allied industries.

One thing which has handicapped our industries is the reluctance of firms to utilise highly educated labour or to adopt scientific methods. In looking round the industries of the district one is struck by the small number of men who have undergone a thorough scientific training at one of the Universities or at one of the leading technical colleges, and who occupy a prominent place in the firms in this district.

The general complaint is that University and college men are too theoretical and not practical.

It is the usual thing for a bad workman to blame his tools, and is it not because employers do not know how to make use of such labour that they utilise it to such a small and imperfect extent?

Things are very different in some other countries with which we have competed in the past, and with which there will be in all probability still fiercer competition in the future. There we find the fullest use made of highly educated scientific labour.

How many engineering firms in this district have a skilled chemist on their staff, and what percentage of these pay him a decent salary? And how many heads of firms have sufficient chemical knowledge to appreciate the work of and utilise the services of such a man because unless there is appreciation of the work done by such a man his services are useless and he becomes discouraged, generally finding himself up against the blank stone wall of there being no appreciation of his services, and yet chemical problems are continually cropping up in engineering work. There is the question of the supply of materials; as a rule the manufacturer trusts to the name of the contractor and assumes that he gets materials of the composition and purity he ordered. Every now and then something goes wrong and the question arises, why? Without a chemist to analyse the material it is often most difficult to say. Apart from this question of the analysis of raw or partly manufactured materials received, there is the chronic question as to the mixtures of the metals in both the metal and brass foundry, and large economies can be effected by systematic analyses.

Another direction in which scientific labour is invaluable is in seeing that instruments are in proper order and that tests are accurately carried out. Tests carried out with inaccurate instruments and without proper scientific precautions to see that they are accurate and reliable are worse than useless, and in fact most misleading and dangerous, as entirely unreliable inferences may be drawn

from them and far-reaching troubles caused in the future. How many tests of steam engines are unreliable because there is no standardisation of the pressure and vacuum gauges and thermometers used, and in how many cases is even the reading of the barometer omitted? An absolute pressure stated as so many inches of vacuum has no meaning unless the barometer reading is also given or the inches of vacuum are stated as reduced to 'Bar. 30.' How many firms using steam have any arrangements for testing vacuum and pressure gauges? And yet there are no instruments more liable to error than these gauges. When one tries to analyse the results of steam tests one is constantly up against the elementary question 'Were the gauges, &c., accurate? What a misfortune it is that there were no means of testing their accuracy.' Under scientific supervision arrangements are made to avoid such troubles and get reliable results which can be depended on for future designs.

What has been said about pressure gauges and the measurement of pressure applies, of course, to all other instruments and measurements. In most works, it may be said with sorrow, that the only moderately accurate measurements that can be made are those of dimensions and weight. It is only by accurate testing of existing plant that reliable deductions can be drawn enabling safe progress to be made in future designs.

One of the great things which helped forward the steam turbine in the early days was accurate and full testing of each plant as soon as it was completed and before it left the works. The late Mr. Willans was probably the first, or one of the first, to recognise the importance of accurate testing of steam plant, and the success his well-known engine had was largely due to this. From the earliest days of the steam turbine, Sir Charles Parsons recognised the necessity of such testing, and the test house has always been a prominent feature of Heaton Works. And then in the higher ranks of engineering works it requires a scientific mind to draw safe conclusions from tests carried out and to see in what directions progress can be safely made. Such methods have enabled the steam turbine during the writer's acquaintance with it, now extending over some twenty-eight years, to grow from 50 horse-power to some 45,000 or more in each unit, and the steam consumption to be reduced from 40 lb. per h.p. hour to about  $7\frac{1}{2}$  lb. or less than one-fifth.

And closely allied to such work in engineering works is the general question of scientific research, and here a trained scientific mind is of the utmost importance to see that reliable results are obtained and to make true logical deductions from those results. Without suitable training a man is liable to be unable to grasp all the conditions of an experiment and to make deductions from the data obtained which are totally unjustified and often lead to most disastrous results in the future.

Such research is generally carried out in four places—engineering works, private laboratories, engineering colleges, and national laboratories.

The first has already been dealt with.

The second is of comparatively small importance in practice.

As regards the third a great deal of good work has been done in engineering colleges, often under great difficulties for want of plant and money, and it is greatly to the credit of our professors and others that they have succeeded in doing so much with the very inadequate appliances at their disposal, and handicapped for want of funds. How inadequate their income is can be understood when it is remembered that Leipzig University alone has an annual income from the German Government of 100,000*l.*, as against a total Government grant to *all* the Universities here of about 45,000*l.*, or less than half.

Of national laboratories we have only one, the National Physical Laboratory at Teddington, and here again the support given to it is totally inadequate. The total income from all sources last year was only 40,000*l.*, and of this 23,000*l.* was charges for work done, such as testing meters and other instruments and such commercial work; the Government grant is only 7,000*l.* a year, and besides this 7,500*l.* was received for experiments in connection with aeronautics, which is really war work. The balance was made up of subscriptions, grants from technical societies, and miscellaneous receipts. Compare this with the German equivalent, the Reichsanstalt of Berlin, which has an income of 70,000*l.* a year from the Government, or ten times that given to our N.P.L. The Bureau of Standards, the similar institution in U.S.A., has

a Government grant of 140,000*l.*, or twenty times ours. In the Civil Service Estimates there is an allowance of 40,000*l.* for research, an increase of 15,000*l.* over that allotted last year. The total estimates are over 20,000,000*l.*, so that less than one-fifth per cent. is allotted to research.

It is difficult to realise what benefits might be gained by investigations which could be carried on by the N.P.L. if only sufficient funds were available, and of what importance they might be to industry at large. One example may suffice. Some time ago the Reichsanstalt carried out a most complete set of tests on a certain class of machine, an investigation which must have cost several thousands of pounds sterling, apart from the time it occupied. The results of this investigation are available to German manufacturers of this machine, and just before the war preparations were being made to take advantage of this, and from figures stated a large extra economy was expected. This, of course, would enable them, provided the cost of manufacture was not too high, to have an enormous advantage over such machines manufactured without this special knowledge. The Institution of Mechanical Engineers saw the importance of this problem and appointed a Research Committee to deal with the question, but the first question met with is that of finance. Should this be the case in a wealthy country such as this that depends on its manufactures for its very existence? And that such an investigation is required is obvious from the fact that the designs of no two independent manufacturers of this machine in this country agree among themselves. Of course, each claims his is the best, but this cannot be so.

Investigations in engineering shops do not meet such a case. The question of finance has to be carefully watched, and as soon as results sufficiently good are obtained they are generally accepted, and in any case the problem is rarely thrashed out to the bottom, an almost universal defect in commercial research work. Without the help of the National Physical Laboratory the position of the aeroplane in this country would be very different from what it is, and what has been done for the aeroplane requires to be done in many other directions.

But what firm here would do what has been done in the commercial synthesis of indigo, on which it is said that seventeen years' work and over 1,000,000*l.* has been spent by one firm alone abroad? Here, in chemical investigations and manufactures, the Government refuse to *even* give the help of allowing cheap alcohol to be obtainable, and much of such work is impossible in this country on this account, as in many cases methylated and denatured alcohol are not suitable. Recently under pressure the restrictions have been somewhat relaxed by the Government, but many manufacturers have found that the privileges granted are so tied up in red tape that the concessions are practically useless.

And it is not only on the scientific side that there is so much to be done in the way of putting our house in order; there is much to be done in the way of putting the management and commercial sides of engineering and other allied works in a position to compete.

The great growth of engineering works and their being formed into limited liability companies have not been without their drawbacks.

In the old days engineering works were comparatively small, and, as a rule, one man, generally a clever engineer, was at the head. After his death, and often before, the place was turned into a limited liability company, and gradually fell into the hands of a body of men, many of them not technical, who had no further interest in the firm than to draw their salaries as directors and managers, and who had no financial stake in the concern beyond the 500*l.* or 1,000*l.* in shares necessary to qualify them as directors. The result is that the place gradually degenerates, initiative ceases, and it finally gets to a stage of not paying any dividends, and really being kept going, not for the sake of the shareholders, but of the directors and other officials.

Such a firm as a rule does not put enough aside for depreciation, and thus its machinery and buildings degenerate and become obsolete, which makes it still less able to compete with more modern firms. At the same time it is not able to afford the money necessary to carry on the experimental and research work which is a necessity for any progressive firm, and thus its manufacturers cease to progress with the times. As Sir Charles Parsons truly said, a man or firm in the face of financial difficulties cannot carry on research work, and,

further, that the minimum spent on research work should be at least one per cent. of the turnover, and that the amount it is advisable to spend is three per cent. Unless a firm makes good profits it cannot keep up to date, and will sooner or later go to the wall.

But the workman says that he should have his share. What is his share under the present state of things? The average capital expended in engineering works per individual employed is about 200*l.* An investigation the writer made some years ago gave this figure, and it was confirmed by an investigation of shipbuilding yards, which gave 185*l.*, and of the Census of Production, which gives a capital of 1,500,000,000*l.* for 7,000,000 workers, or 214*l.* per man. An investigation of the dividends paid shows them to be about 4 per cent. on the capital employed. Here it must be remembered that firms paying 10 to 15 per cent. on their ordinary capital have often a large preference and debenture capital, on which a much lower rate of interest is paid, and also that often part of the ordinary capital was issued at a premium. Also account has to be taken of the large number of companies that do not pay any dividend on their ordinary stock, and often none on their preference. Little is as a rule heard of the finances of such companies; it is the ones paying good dividends that public attention is drawn to.

It thus means that the shareholders get about 8*l.* per year per individual employed.

On the other hand, the average wages for men and boys, skilled and unskilled, is about 70*l.* per annum in normal times. This means that the worker gets between eight and nine times as much as the capitalist, and shows on what a very small margin the capitalist works. And without the capitalist, under our present system of individualism, there would be no factories erected and run, and therefore no work for the working-man, a thing it is well for him to remember, and also that without profits the capitalist will not invest in engineering and other works in this country, but will seek for a more profitable field for his capital elsewhere. Every 200*l.* invested in this country in a factory means work and livelihood for one British working-man.

At the same time I am sorry to say the employer does not look after the welfare of his workmen as he might. In a small factory the head of the firm, as a rule, knows all the leading men among the workmen, many of them having been with him for years. As the place grows he loses touch with his men, and as an actual fact knows fewer of those under him when he has 1,000 or more employees than he did when he had 400 or under. This state of things gets worse when the place is turned into a limited liability company, as nearly all large places are at present. The result is that a most deplorable state of things has come to pass. The workman says, 'Put not thy trust in employers'; the master says, 'Put not thy trust in workmen'; and the official who is between the master and the workman says, 'Put not thy trust in either.'

It is difficult to say what is to be done to remedy this state of things, but one cannot help feeling much might have been done in the past to have prevented such a regrettable state of affairs as there is at present. Much of this trouble might have been avoided if employers had shown more consideration for the welfare of their workmen. Of course there are some notable exceptions, but they are few and far between. An example is the necessity of the Factory Acts to ensure proper light and air and other arrangements necessary for the health of the workmen. But much more should be done. Why is it that canteens are being rushed up all over the country, and why were there so few before? In many works to this day the provisions for getting food and drink warmed are most primitive and inefficient, and as to getting anything to eat if one has to work overtime unexpectedly, it is in most works impossible. As a rule the only thing available was a drink at the public house outside the gates, and even this is now closed at five o'clock. Why if a man works overtime should he also starve? And how can efficient work be expected under such conditions? Why also should there not be provision for drying clothes after walking to work on a wet morning, and each man be provided with a cupboard where he could keep a change of boots? Why are not sanitary arrangements decently private, and why are they not kept clean and wholesome? They are often in a disgraceful state. These are only a few samples of the directions in which much might be done.

The adjustment of the wages to be paid to the workman is a most difficult one. There are three principal ways of paying workmen: on time, on piece, and on bonus.

On time is the only way of paying a man who is on various classes of work, where the fair time required for each job is not known, and in many cases the most highly skilled men are on such work and as a result only make time wages. This results often in the highly skilled man making less money than the less skilled man who is on repetition work and as a consequence is working on piece or bonus, and this is obviously unfair. For example, a man may have the setting up and adjusting of a number of machines on repetition work, and he often makes less money than the less skilled men under him who are on piece or bonus, although their nominal rate of wages is less than his.

Again, highly skilled erectors who go outside the works to erect machinery, often worth thousands of pounds, and set it to work, are only paid on time, and often make less money than their fellows who are on piece inside the works.

The adjusting of piece prices is a most difficult one. They should be adjusted so as to be fair both to master and man, but too often such fixing of prices is left to subordinate officials who have in many cases their own axe to grind. There should in all works be a special department for such fixing of prices, and once a price is fixed it should not be altered without good reason. The practice of cutting prices by the masters in the past is, in the opinion of the writer, largely responsible for the present limitation of output by the men about which we hear so much. There is a rule that if a man makes more than time and half or time and third the price of the job is to be cut. If the price has been fairly fixed why should it be reduced because the man makes large wages due to his skill and industry? The larger the output from his vice or lathe the better for the master, as he is getting a larger output from his plant with a certain capital expenditure, and thereby establishment charges are reduced. This is especially the case in machine work, as the hourly value of the machine employed often far exceeds the wages of the workman employed.

A fair rating for machine tools is 4*d.* per hour per 100*l.* value, and as the time rating of the man is generally about 9*d.*, it is easily seen that if the average value of the machine tools exceed 225*l.* machine charges exceed time wages, and the average value of machine tools is generally largely in excess of this figure, in fact often about double it. It is therefore obvious that it is much more important to get large output than to pay small wages.

The result of this 'time and half' rule is that a good man, by working up to the limit of his capacity, 'spoils the job' for the next man who comes along and may not be of the same calibre as the first man. It has therefore been found advisable and necessary by the workmen to limit the output of all men to a certain standard, and this results in the end by the pace being set by the slowest man on a particular job.

A fair bonus system is perhaps the ideal way of paying men, but here, again, although the times for a job are supposed to be fixed and unalterable, in too many cases they have been altered by various devices, and as a result the system is looked on with suspicion by the workman.

Gradually bit by bit the pernicious doctrine that the less work done by a man the more employment there will be has grown up, he not seeing that the cheaper an article can be produced the larger will be the sale for it and the better it will be able to compete with the products, not only of other producers in this country but of those abroad. And also that very cheapness, combined with good quality, induces the sale for such articles to be large.

Laziness is inherent in man, and *on an average* no man will work unless compelled to do so, and still less will work his best unless there is a great inducement. This is true not only of the working-man but of all other classes. Therefore the policy of 'Ca' Canny' has been only too readily adopted on the ground not only that it was pleasant for the man himself but also he believed that it tended to the welfare of his fellow-workmen.

The writer has very reluctantly come to the conclusion that the workman of to-day is not doing as much work as was done some thirty years ago when he was in the shops, and not only this, but that timekeeping is not as good. In this connection, however, it must be remembered that excessive overtime inevitably leads to bad timekeeping.

Bad timekeeping causes much more loss than that due to the actual time lost, as not only does machinery and other plant lie idle, but the disorganisation caused in works by lost time is most serious.

With the growth in strength of the Trades Unions, which at first were for the legitimate object of seeing that the workman got fair play, and providing out-of-work and old-age benefits, &c., has grown up a system of Trades Union officials who live by agitation, and whose job would be gone if there were no supposed grievances to agitate about. These men keep the labour world in a constant state of agitation, and make the employers' and officials' existence a burden to them by constant demands of all sorts, many of them utterly impracticable and unfair. When they cannot agitate against the employer they agitate against another Trades Union, and thus endless disputes spring up on the demarcation of work. Some of the worst strikes in the past have been due to disputes between two Trades Unions.

Unless something can be done to bring master and man together and make both work for the common good, English trade must inevitably go down, and the supremacy that England has in the engineering of the world will come to an end.

Nothing ever was a truer statement than that recently made by Lord Joicey that this country, unless it produces as cheap or cheaper than other countries, cannot in the long run keep her trade, and this is true in spite of any tariff walls which may be set up. And if the present state of affairs is maintained of unscientific management and obsolete machinery, combined with limitation of output and high wages, or, in other words, high cost of production, we must, sooner or later, go to the wall.

What is really wanted is common honesty and common sense on both sides, for one side is as bad as the other at present.

And now about the official, who is in all grades from the manager down to the foreman, and who comes between the master and the man. Unless he is treated fairly by the master, and unless he treats his men fairly, there is sure to be friction and loss of efficiency. He must also work with his fellow-officials, who move in lines more or less parallel to his, and here, to prevent jealousies and to prevent the more unscrupulous among them taking unfair advantages, demarcation of each official's duties and work is most important. This is a point often omitted to be taken sufficiently into account in the organisation of works, and often causes most disastrous results. The duties of each man should be clearly defined by the master, and no interference with those of others tolerated. The master also should remember that the official has no Trades Union or similar organisation to protect him, and should act accordingly. Much more could be said about the relations of the official both with his fellow-official who is on the same level as himself, with his master who is above him, and the workman who is under him, but time forbids. On all three sides much improvement could be effected. The fact remains, however, that for success it is essential that all from the apprentice to the head of the firm should work as one homogeneous whole.

Apart from the considerations set out above, combinations among the firms employed in any one trade are most essential for the well-being of that trade. It is by such combination that much of the progress made of late years by our competitors has been effected. Some of these combinations have been international, and at least two such in the engineering trade before the war were so. These now, of course, are, and it is expected will be after the war, confined to the allied and possibly to neutral countries, but such combinations, whether among all the engineering firms in one district or among firms employed in one particular trade, to be successful must be worked fairly to all members, and the larger firms must not override the smaller, as, it is regrettable to say, has been done in combinations of employers in some districts. For example, in a district where there is one firm very much larger than any of the others, it is not unknown for it to act the bully and insist on everything being done as would suit its requirements, regardless of the rights of others. And, further, such combinations are, unless directed by men with broad minds and able to take a wide view of things, apt, especially in case of emergency, to do much harm.

If the Armament Ring in this country had taken such a view when it was found what an enormous supply of munitions was required, it is doubtful if there would have been such a shortage as there has been. Hundreds of firms were willing and anxious to help in the production of munitions, but when they offered their services they were met in many cases with a blank refusal, and in all cases with little encouragement. And when, under pressure from the Government, the Ring accepted outside help, in many cases the conditions imposed on the sub-contractors were unfair in the extreme, apparently the whole idea of the Ring being to make all the profit they could out of the troubles of the Empire. It has been just as difficult to persuade the Armament Ring to give up what they thought was their monopoly and to bring in outside works to help in the production of munitions as it has been to persuade the Trades Unions to forgo trade customs and to enable outside sources of labour to be employed, such as women and other unskilled labour. But both have had to do it. In other words, 'Dilution of Works' has been as difficult to effect as 'Dilution of Labour,' and the position of both the Armament Ring and of the workman would have been very different if they had consented freely to it when it became obviously necessary for the safety of the Empire.

Combination among workmen is admittedly a necessity if they are to have fair play, but combination among employers has come later and is equally a necessity.

At present most of the principal federations of employers deal only with wages questions and questions affecting labour, but they require to be extended so as to take in all branches of the business of engineering. Labour has long seen the importance of federation; it is now for Capital to do the same. One of the great difficulties has been that certain firms would not join, and a very small proportion acting thus weakens the whole to a much greater extent than the actual ratio of this small proportion of the whole. It is easy to see how alive Labour is to this by the constant trouble over the Non-Union question, and this is well put in the notice addressed last March to the Transport Workers of the Mersey district, 'To be outside a Union is to be disloyal not only to your own class but to yourselves individually.' What applies to Labour also applies to firms; for a firm to be outside the Federation is to be disloyal, not only to its fellow-firms but to itself.

Such a state of affairs is not tolerated in some of the countries competing with us, and it is questionable whether action by the Government is not advisable.

An example of the mischief done by a few who would not fall into line with the many is seen by the necessity for the Act compelling the early closing of shops one day a week. The great majority were ready to close, but the action of a small minority prevented their doing so, and in the end compulsion had to be used on the minority. Legislation has not been necessary to prevent 'black-legging' in the labour world since other methods have been used which have been practically successful, but it is quite possible it may be necessary to use compulsion to make firms toe the line.

Such combinations are not only for labour questions but also for all other subjects affecting the engineering industry at large, and more especially the special industries in which any one firm deals. Thus they resolve themselves into general federations of all engineering industries and minor ones dealing with particular trades.

The former deal chiefly with labour questions and questions affecting the industry as a whole, the latter with those affecting any particular trade.

Among the questions coming up to be considered by the latter class is the standardisation of specifications and conditions of contracts as well as in some cases the adjusting of prices to avoid unfair competition and to put the whole trade on a paying basis. Much has been done in this direction with most advantageous results in certain cases, but much more remains to be done if this country is going to hold its place in the world.

The necessities of research work have already been dealt with, and by the pooling of such research work enormous advantages in any one trade could be obtained. Such pooling of information has been effected with most beneficial results, especially in the chemical trade abroad. Any workable scheme which



would enable this to be done and get over the jealousies between one firm and another would be of enormous benefit to the trade in general.

Another thing that must not be lost sight of is the urgent need of improving our educational system. It is little short of a disgrace that the older Universities are closed to those without a knowledge of Latin and Greek.

Languages are of the greatest importance to an engineer—not dead languages but live ones. And these should be properly taught, so that the student should not only be able to read and write them but also to speak and understand them. It is quite a different knowledge of a language to be able to read, write, speak, or understand it. Many people can read a language without being able to write, speak, or understand it, and conversely it is not uncommon to meet people who can speak and understand a language without being able to any large extent to read or write it. And it is only in live languages that a man is trained to speak and understand a language.

Why is it that we are so wedded to the dead languages? There is, of course, the tradition that such are necessary for a liberal education, and there is the argument that modern languages are not as good a training for the mind. Granted that they are not quite so good from the point of view of learning to read and write them, does not the fact that they can also be taught as a live language to be spoken and understood make them on the whole the best educationally for a man? This is entirely apart from the fact that modern languages are useful and ancient useless to the man in commercial work. There is, of course, bitter opposition from that most conservative man, the schoolmaster, and one great reason is that it is much easier and cheaper to get a man to teach Latin and Greek than modern languages which have to be taught orally. The teaching of Latin and Greek as they are usually taught has been standardised to the last degree, and as a result they can be taught by the 'semi-skilled' man, and a 'skilled' man is not necessary, to use engineers' phraseology. In fact, teaching of Latin and Greek is a pure 'repetition job.' At the same time no education is complete unless science is combined with languages and also literature, and here lies one great danger of modern technical education.

And after the boy has left school and enters the shops more facilities should be given to enable him not only to keep up but continue his education. In the shops and drawing office too often the boy is left to pick up a knowledge of his trade as best he can. The apprentice who asks questions is often looked on as a nuisance, and requests for information are generally met by a blank refusal or worse. Often the foreman or chief draughtsman is afraid to answer questions for fear of being charged with giving away so-called 'trade secrets,' but an immense deal of information can be given to an apprentice without doing so.

Evening classes are all very good in their way, but more facilities should be given for the diligent apprentice to attend day classes, and this can be arranged in various ways if the employer has a will to do it. A thing that at present often prevents boys desirous of educating themselves getting on is the fact that overtime is allowed as soon as a boy is eighteen, and often he is compelled to work overtime regardless of classes that he ought to be attending.

It is important to remember that the boy of to-day is the man of to-morrow.

One complaint is that after a lot of trouble is taken about a boy he leaves after a few years and goes to another employer. The good of the trade in general must be considered, and a man who has had experience of various classes of work is generally a much more valuable man than one whose knowledge is confined to one class only. In any case the other employer gets the benefit of what has been done by the first, and thus the trade in general benefits.

It is felt that this is a very imperfect review of things as they are at present, but if this address induces all classes engaged in engineering to consider how things can be bettered the author feels that a part, at all events, of his object has been attained.

The following Paper was then read :—

*Limit Gauges.*<sup>1</sup> By Dr. R. T. GLAZEBROOK, C.B., F.R.S.

---

THURSDAY, SEPTEMBER 7.

The following Papers and Reports were received :—

1. *The Principle of Similitude in Engineering Design.*<sup>2</sup>  
By Dr. T. E. STANTON, F.R.S.

---

2. *Standardisation and its Influence on the Engineering Industries.*<sup>3</sup>  
By C. LE MAISTRE (with a Foreword by Sir JOHN WOLFE-BARRY, K.C.B., F.R.S.).

---

3. *Pressure Oil Film Lubrication.*<sup>4</sup> By H. T. NEWBIGIN.

---

4. *The Influence of Pressure on the Electrical Ignition of Methane.*<sup>5</sup>  
By Professor W. M. THORNTON, D.Sc.

---

5. *Some Experiments on the Possibility of working Diesel Engines with Low Compression Pressures.*<sup>6</sup> By Professor W. H. WATKINSON.

---

6. *Interim Report on Gaseous Explosions.*—See Reports, p. 292.

---

7. *The Calculation of the Capacity of Aerials, including the Effects of Masts and Buildings.*<sup>7</sup> By Professor G. W. O. HOWE, D.Sc.

---

8. *Some Characteristic Curves for a Poulsen Arc Generator.*<sup>8</sup>  
By N. W. MCLACHLAN.

---

9. *Interim Report on Complex Stress Distribution.*  
See Reports, p. 280.

---

10. *Report on Engineering Problems affecting the Future Prosperity of the Country.*

---

<sup>1</sup> Published in *Engineering*, vol. 102, p. 236.

<sup>2</sup> Published in *Engineering*, vol. 102, p. 266.

<sup>3</sup> Published in *Engineering*, vol. 102, p. 240.

<sup>4</sup> Published in *Engineering*, vol. 102, p. 264.

<sup>5</sup> Published in *The Electrician*, vol. 77, p. 775.

<sup>6</sup> Published in *Engineering*, vol. 102, p. 290.

<sup>7</sup> Published in *The Electrician*, vol. 77, pp. 761, 880.

<sup>8</sup> Published in *The Electrician*, vol. 77, p. 883.

## FRIDAY, SEPTEMBER 8.

*Joint Discussion with Section B of the Report of the Committee  
on Fuel Economy.*

Professor W. A. Bone, Dr. J. T. Dunn, Dr. J. E. Stead, Mr. H. J. Yates, Mr. C. H. Merz,<sup>1</sup> Sir Hugh Bell, Professor H. Louis, Sir Chas. Parsons, Dr. Dugald Clerk, Professor H. B. Dixon, Dr. des Voeux, Dr. E. F. Armstrong, Mr. C. E. Stromeyer, Mr. Blackett, Professor G. G. Henderson, Mr. Gerald Stoney, Mr. R. P. Sloan,<sup>2</sup> Mr. McLaurin, Mr. Woodhouse, Mr. Chamen, Mr. A. H. Barker, and Mr. Highfield took part in the discussion.<sup>3</sup>

<sup>1</sup> Mr. Merz's contribution to the discussion was published as a paper in *Engineering*, vol. 102, p. 262, and in *The Electrician*, vol. 77, p. 915.

<sup>2</sup> Mr. Sloan's contribution was similarly published in *Engineering*, vol. 102, p. 293, and in *The Electrician*, vol. 77, p. 917.

<sup>3</sup> An abstract of the whole discussion was published in *Engineering*, vol. 102, p. 272.

---

## SECTION H.—ANTHROPOLOGY.

PRESIDENT OF THE SECTION: R. R. MARETT, D.Sc.

The President delivered the following Address on Friday, September 8:—

*Anthropology and University Education.*

HAD Fate been more kindly, we of this Section would to-day have been listening to a Presidential Address delivered by Sir Laurence Gomme. Thus, on meeting together, our first thought is about the gap in the ranks of science caused by his death. He studied and enriched Anthropology chiefly on the side of folklore, having been in no small part responsible for the foundation and subsequent development of the well-known society that devotes itself to this branch of the subject. As one who is officially connected with the society in question, I am under a special obligation to honour his memory. If its researches have all along been conducted on strictly scientific lines, if it be not unworthy to take its place by the side of the Royal Anthropological Institute as a body of co-workers and co-helpers who participate in precisely the same intellectual ideals (and a proof of such a recognised community of aim is to be found in the fact that most of us are proud to be members of both organisations alike), the credit is largely due to Sir Laurence Gomme, to Lady Gomme who shared in his labours to such good purpose, and to those many personal friends of his who, kindled and kindling by mutual give and take, inspired each other to cultivate Anthropology in the form in which it lies nearest to our doors. A busy Londoner, if ever there was one, and, what is more, a Londoner loving and almost worshipping his London, Sir Laurence Gomme yet managed to cultivate the sense of the primitive, and, amid the dusty ways of the modern city, could himself repair, and could likewise lead others, to fresh and quiet spots where one may still overtake the breath of the morning.

I shall not attempt now to deal in detail with his diverse contributions to science. They have become classical, forming by this time part and parcel of our common apparatus of ideas. But it may be in point here to suggest some considerations of a general nature touching his enlightened conception of anthropological method. In the first place, he would never suffer Anthropology to be thrust into a corner as a mere sub-section of History. On the contrary, he perceived clearly that History in the sense of the history of European civilisation is but a sub-section of the universal history of man, in other words, of Anthropology; which is just such a history of universal man conceived and executed in the spirit of science. Perhaps the folklorist is in a better position to appreciate the continuity of human history than his anthropological colleague, the student of backward races. For it is constantly borne in upon him how the civilised man is only a savage evolved; whereas how the actual savage is ever to be civilised is, alas! usually not so evident. Moreover, Sir Laurence Gomme's interests lay chiefly among such problems as pertain

to the transitional period in the history of this country that connects the chronologically primitive with the modern. We need more students willing and able to undertake such bridge-work. So long as we merely attack human history at its two ends (so to speak), there will be on the part of the several groups concerned a tendency to lose touch. They will thus be apt to exaggerate such divergence in respect to working methods as must inevitably occur whenever there is the slightest difference as regards quality of subject-matter. There is much that I could say, did time allow, about the value of proto-history, as it is sometimes termed, that is, the study of the emergence of civilisation out of barbarism, as a means of fostering a deeper sense of solidarity between those who study human development from the contrasted standpoints of a rudimentary and a matured culture. All honour, then, to Sir Laurence Gomme as a pioneer in this little-frequented field. Again, let us honour him as an early promoter of that so-called ethnological method of which so much has lately been heard. This point is well brought out in a very sympathetic account of Sir Laurence Gomme's life-work from the pen of Dr. Haddon. I need not here anticipate what I have to say about the scientific and educational importance of such a method and point of view. My only concern at present is to lay stress once more on those qualities of the true pioneer, the initiative, the self-reliance, the divinatory impulse, which we shall always associate with the memory of Sir Laurence Gomme. Science as well as war has its roll of honour; and therein, for our encouragement, let us reverently inscribe his name.

The question to which I beg to call attention on the present occasion is, What function ought Anthropology to fulfil among the higher studies of a modern University? The subject may be commonplace, but it is certainly not untimely. At the present moment those of us who are university teachers in any of the warring countries are feeling like fish out of water. Our occupation is to a large extent suspended; and already it seems a lifetime since we were assisting, each after his own fashion, in the normal development of science.

*Usus abit vitæ: bellis consumpsimus ævum.*

Can the hiatus be bridged, the broken highway mended? Never, if memories are to prevail with us; but, if hopes, then it goes equally without saying that we shall somehow manage to carry on more actively and successfully than ever. So the only problem for brave and hopeful men is, How? Ignoring our present troubles, we are all thinking about the future of University education, and reform is in the air.

Of course, every University has difficulties of its own to meet; and my own University of Oxford, with eight centuries of growth to look back on, is likely to be more deeply affected by the sundering of traditions due to the War than such of its sister-institutions as are of more recent stamp. Now, when I discuss University matters, the case of Oxford is bound to weigh with me predominantly; and, indeed, no man of science could wish me to neglect what after all is bound to be my nearest and richest source of experience. But various kind friends and colleagues hailing from other Universities in Great Britain, France, and the United States have furnished me with copious information concerning their home conditions; so that I shall not altogether lack authority if I venture to frame conclusions of a general nature. Besides, it is not on behalf of any University but rather as representing the interests of the science of Anthropology, that I am entitled to speak in my present capacity. I do indeed firmly hold that anthropological teaching and research can be admitted to the most ample status in the curriculum of any modern University without injury to established industries and activities. But even if this were not so—even if it needed a sort of surgical operation to engraft the new in the old—we anthropologists must, I think, insist on the fullest recognition of our science among University studies, realising as we are especially able to do its immense educational value as a humanising discipline. Let me not, however, rouse prejudice at the outset by seeming to adopt an aggressive tone. 'Live and let live' is the safest motto for the University reformer; and I have no doubt that the peaceful penetration whereby Anthropology has of late been almost imperceptibly coming to its own in the leading Universities of the world will

continue to accomplish itself, if we, who make Anthropology our chief concern, continue to put forth good work in abundance. For, like any other science, the science of man must be justified of its children.

Now, it is customary to contrast what are known as technical studies with University studies proper; and such a distinction may prove helpful in the present context, if it be not unduly pressed. Thus, in particular, it will afford me an excuse for not attempting to travel afresh over the ground covered by Sir Richard Temple in his admirable Presidential Address of three years ago. What he then demanded was, as he termed it, a school of Applied Anthropology, in which men of affairs could learn how to regulate their practical relations with so-called 'natives' for the benefit of all concerned. Let me say at once that I am in complete agreement with him as to the need for the establishment or further development of not one school only but many such schools in this country, if the British Empire is to make good a moral claim to exist. Indeed, I have for a number of years at Oxford taken a hand in the anthropological instruction of probationers and officers belonging to the public services, and can bear witness to the great interest which students of this class took at the time, and after leaving Oxford have continued to take, in studies bearing so directly on their life-work.

What I have to say to-day, however, must be regarded as complementary rather than as immediately subsidiary to Sir Richard Temple's wise and politic contention. The point I wish to make is that, unless Anthropology be given its due place among University studies proper, there is little or no chance that technical applications of anthropological knowledge will prove of the slightest avail, whether attempted within our Universities or outside them. Anthropology must be studied in a scientific spirit, that is, for its own sake; and then the practical results will follow in due course. Light first, fruit afterwards, as Bacon says. So it has always been, and must always be, as regards the association of science with the arts of life. That Sir Richard Temple will heartily subscribe to such a principle I have no doubt at all. As a man of affairs, however, whose long and wide experience of administration and of the problems of empire had convinced him of the utility of the anthropological habit of mind to the official who has to deal with 'all sorts and conditions of men,' he naturally insisted on the value of Anthropology in its applied character. On the other hand, it is equally natural that one whose career has been wholly academic should lay emphasis on the other side of the educational question, maintaining as an eminently practical proposition—for what can be more practical than to educate the nation on sound lines?—the necessity of establishing Anthropology among the leading studies of our Universities.

How, then, is this end to be attained? The all-important condition of success, in my belief, is that all branches of anthropological study and research should be concentrated within a single School. For it is conceivable that a University may seek to satisfy its conscience in regard to the teaching of Anthropology by trusting to the scattered efforts of a number of faculties and institutions, each of which is designed in the first instance to fulfil some other purpose. Thus for Physical Anthropology a would-be student must resort to the medical school, for Social Anthropology to the faculty of arts, for Linguistics to the department of philology, for Prehistorics to the archaeological museum, and so on. Such a policy, to my mind, is a downright insult to our science. Is the anthropologist no better than a tramp, that he should be expected to hang about academic back-doors in search of broken victuals? Fed on a farrago of heterogeneous by-products, how can the student ever be taught to envisage his subject as a whole? How, for instance, is he ever to acquire the comprehensive outlook of the competent field-worker? Such a makeshift arrangement can at the most but produce certain specialists of the narrower sort. In 'The Hunting of the Snark' they engaged a baker who could only bake bride-cake. Anthropological expeditions have, perhaps, been entrusted before now to experts of this type; but they have not proved an entire success. I am not ashamed to declare that the anthropologist, be he field-worker or study-worker—and, ideally, he should be both in one—must be something of a Jack-of-all-trades. This statement, of course, needs qualification, inasmuch as I would have him know everything about something as well as something about everything. But

the pure specialist, however useful he may be to society in his own way, is not as a rule a man of wide sympathies; whereas the student of mankind in the concrete must bring to his task, before all else, an intelligence steeped in sympathy and imagination. His soul, in fact, must be as many-sided as that complex soul-life of humanity which it is his ultimate business to understand.

Suppose it granted, then, that the anthropological studies of a University must be united in a single School, how is this to be done? In this examination-ridden land, the all-important first step is that Anthropology be admitted to an independent place in the examination-system of the University concerned. Whether such a principle would hold good of other countries, as, for instance, of the United States, I am not sure. In America, indeed, the simplest way to start a subject would seem to be to get a millionaire to endow it. But here let it suffice to deal with the conditions most familiar to us; amongst which alas! millionaires are hardly to be reckoned. Now, much depends, of course, on what sort of place the subject is accorded; for there are higher and lower seats at the feast of reason which a British University in its examinational capacity provides for its hungry children. It is largely a question of the form of distinction—the degree or other badge of honour—with which success is rewarded. Thus the examination in Anthropology may be made an avenue to the Bachelor's degree, to some higher degree such as that of Master, or to some special certificate or diploma. Further, ambition will be stimulated accordingly as classes or other grades of achievement are recognised within the examination itself. But these are matters of occasion and circumstance, such as must be left to the discretion of the *genius loci*. The essential requirement is that Anthropology should figure in the examination-system with a substantive position of its own.

If there is to be an examination in Anthropology, some official body must exist in order to arrange and administer it. It is possible, indeed, to hand over such a function to an organisation already saddled with other duties. In that case it is extremely improbable that the new and, as it were, intrusive subject will be given its fair chance. Preferably, then, Anthropology should be committed to the charge of a special Board. The members of such a Board need not one and all be professionally concerned with the teaching of Anthropology; though, as soon as a teaching staff comes into being, its leading members will naturally be included. On the contrary, it is advisable that representatives of a goodly number of those disciplines which take, or ought to take, an interest in human origins should participate in the deliberations of such a governing body. Biology, Human Anatomy, Archæology, Geology, Geography, Psychology, Philology, History, Law, Economics, Ethics, Theology—here are a round dozen of organised interests from which to select advisers. To be effective, of course, an organising committee must not be too large; and it may be necessary, if the Board of Anthropological Studies be constituted on the wide basis here suggested, that it should depute its executive functions to a Sub-Committee, merely retaining a right of general superintendence. But the principle that Anthropology is a blend or harmony of various special studies is so important that its many-sidedness must somehow be represented in the constitution of the central authority which controls the destinies of the subject.

Least I seem to dwell too long on questions of mere machinery, I do not propose to deal at length with the activities which such a Board is bound to develop. When we come to consider presently how the subject of Anthropology needs to be conceived with due regard alike to its multiplicity and to its unity, we shall in effect be discussing the chief function of a Board of Studies, which is to prescribe, for examination purposes, an ordered scheme of topics based on an accurate survey of the ground to be covered. Everything turns on providing an adequate curriculum at the outset. The teaching arrangements will inevitably conform thereto; and, unless the division of labour correspond to a sound and scientific articulation of the subject, chaos will ensue. For the rest, the powers granted to such a Board can hardly be too wide. Thus at Oxford the experiment has answered very well of constituting a Committee of Anthropology which not only examines, prescribes the programme of studies, and arranges courses of instruction, but is likewise authorised to manage its own finances, to organise anthropological expeditions, to make grants for research, and, generally, to advance the interests of Anthropology in whatever way may seem to it good and feasible. So much for what is, indeed, the obvious principle

that, if there is to be a school of Anthropology at all, it must enjoy a liberal measure of self-government.

Given, then, an independent, centrally governed school of Anthropology, must it be housed within the walls of a single Institution? Such a requirement is perhaps to be regarded as a counsel of perfection; since it may be necessary to make a start, as, for instance, we had to do at Oxford, without commanding the resources needful for the providing of accommodation on a suitable scale. Nevertheless, to bring all the anthropological studies together within the same building is, I think, highly desirable in the interests both of science and of education; and this building, I suggest, should be for choice an ethnological museum, such as the Peabody Museum of Harvard University. Lacking such a museum altogether, a University can scarcely aspire to teach Anthropology in any form. On the other hand, for teaching purposes the museum need not be a very elaborate or costly affair. I am not competent, indeed, to deal with the vexed question of museum organisation, and must altogether avoid such a problem as whether an ethnological collection should primarily be arranged on a geographical or on a typological plan. But this much at least I would venture to lay down, that it is salutary for any ethnological museum, and especially for one connected with a University, to be associated with the systematic teaching of Anthropology. When this happens it soon becomes plain that, in order to serve educational ends, a museum should abound rather in the typical than in the rare. The genuine student of Anthropology pays no heed to scarcity values, but finds the illustrative matter that he needs largely in common things which have no power to excite the morbid passion known as collector's mania. Or, again, if both the instructor and the pupil have had a sound anthropological education, they will have no use for objects torn by some 'globe-trotter' from their ethnological context and hence devoid of scientific meaning; and yet the museums of the world are full of such *bric-à-brac*, and in former less-enlightened times have done much to encourage this senseless and almost sacrilegious kind of treasure-hunting.

Further, if all courses of anthropological instruction are held in the immediate neighbourhood of a rich store of material, osteological, archæological, and technological, no teacher can afford to treat his particular topic as one wholly relative to ideas as distinct from things. I can conceive of no branch of the subject, with the possible exception of linguistics, that does not stand to gain by association with objects that appeal to the eye and touch. There is a real danger lest Anthropology on its social side be too bookish. Much may be done to supplement a purely literary treatment by the use of a lantern, not to mention the further possibilities of a cinematograph supported by a phonograph; and I was much struck on the occasion of a recent visit to Cambridge by the copious provision in the way of slides which Professor Haddon has made for lecturing purposes. Even more, however, is to be gathered from experience of the things themselves, more especially if these be so arranged as to bring out their functional significance to the full. Thus, however carefully we might have studied the works of Sir Baldwin Spencer beforehand, those of us who had the privilege two years ago of visiting the Melbourne Museum under his guidance must have felt that but half the truth about the Australian aborigines had hitherto been revealed to us. Or, again, if our buildings and, let me add, our finances were sufficiently spacious, how valuable for educational purposes it would be to follow the American plan, so well exemplified in the great museums of Washington, New York, and Chicago, of representing pictorially, by means of life-size models furnished with the actual paraphernalia, the most characteristic scenes of native life!

There are many other aspects of this side of my subject on which I could enlarge, did time allow. For example, I might insist on the value of a collection illustrating the folklore of Europe, and that of our own country in particular, as a means of quickening those powers of anthropological observation which our students may be taught to exercise on Christians no less intensively than on cannibals. But I must pass on, simply adding that, of course, such an anthropological institution must be furnished with a first-rate library, including a well-stocked map-room. America, by the by, can afford us many useful hints as to the organisation of a library in connection with University education. Thus I lately noted with admiration, not unmixed with envy, how



the University of California furnishes each class of students with a special sanctum where the appropriate literature is collected for them ready to hand. To arrange such seminar libraries, as they may be termed, is quite simple, if only the library officials and the teaching staff can be induced to co-operate intelligently.

I come at length to the root of the problem. It has sometimes been objected that, however much we strive by means of organisation to invest Anthropology with an external semblance of unity, the subject is essentially wanting in any sort of inner cohesion. Nor does such criticism come merely from the ignorant outsider; for I remember how, when the programme for our Diploma Course at Oxford was first announced to the world, Father Schmidt found fault with it in the columns of 'Anthropos' on the ground that it was not the part of one and the same man to combine the diverse special studies to which we had assigned a common anthropological bearing. In the face of such strictures, however—and they were likewise levelled at us from quarters nearer home—we persisted in our design of training anthropologists who should be what I may call 'all-round men.' Let them, we thought, by all means devote themselves later on to whatever branch of the subject might attract them most; but let them in the first instance learn as students of human life to 'see it steadily and see it whole.' Since this resolve was taken, a considerable number of students has passed through our hands, and we are convinced that the composite curriculum provided in our Diploma Course works perfectly in practice, and, in fact, well-nigh amounts to a liberal education in itself. It is true that it cuts across certain established lines of demarcation, such as, notably, the traditional frontier that divides the faculty of arts from the faculty of natural science. But what of that? Indeed, at the present moment, when the popular demand is for more science in education—and I am personally convinced that there is sound reason behind it—I am inclined to claim for our system of combined anthropological studies that it affords a crucial instance of the way in which natural science and the humanities, the interest in material things and the interest in the great civilising ideas, can be imparted conjointly, and with a due appreciation of their mutual relations.

Now, there is tolerable agreement, to judge from the University syllabuses which I have been able to examine, as to the main constituents of a full course of anthropological studies. In the first place, Physical Anthropology must form part of such a training. I need not here go into the nature of the topics comprised under this head, the more so as I am no authority on this side of the subject. Suffice it to say that this kind of work involves the constant use of a well-equipped anatomical laboratory, with occasional excursions into the psychological laboratory which every University ought likewise to possess. It is notably this branch of Anthropology which some would hand over entirely to the specialist, allowing him no part or lot in the complementary subjects of which I am about to speak. I can only say, with a due sense, I trust, of the want of expert knowledge on my part, that the results of the purely somatological study of man, at any rate apart from what has been done in the way of human paleontology, have so far proved rather disappointing; and I would venture to suggest that the reason for this comparative sterility may lie, not so much in the intrinsic difficulties of the subject, as in a want of constructive imagination, such as must at once be stimulated by a fuller grasp of the possibilities of anthropological science as a whole.

In the next place, Cultural as distinct from Physical Anthropology must be represented in our ideal course by at least two distinct departments. The first of these, the Department of Prehistoric Archaeology and Technology, involves the use of a museum capable of illustrating the material culture of mankind in all its rich variety. Here instruction will necessarily take the form of demonstration-lectures held in the presence of the objects themselves. To a limited extent it should even be possible to enable the student to acquire practical experience of the more elementary technological processes, as, for instance, flint-knapping, fire-making, weaving, the manufacture of pottery, and so on. May I repeat that, to serve such educational purposes, a special kind of museum-organisation is required? Moreover, it will be necessary to include in the museum staff such persons as have had a comprehensive training in Anthropology, and are consequently competent to teach in a broad and humanising way.

The other department of Cultural Anthropology is one that embraces a considerable complex of studies. At Oxford we term this branch of the subject Social Anthropology, and I do not think that there is much amiss with such a title. Among the chief topics that it comprises are kinship- and marriage-organisation, religion, government, law, and morals. Further, economic and aesthetic developments have to be examined in their reference to the social life, as apart from their bearing on technology. In one aspect, all these subjects lend themselves to a sociological method of treatment; and, though no one is more concerned than myself to insist on the paramount importance of psychology in the equipment of the perfect anthropologist, I would concede that the sociological aspect ought as far as possible to be considered first, as lending itself more readily to direct observation. To reveal the inner workings of the social movement, however, nothing short of psychological insight will suffice. Indeed, all, I hope, will agree that the anthropologist ought to be so trained as to be able to fulfil the functions of sociologist and psychologist at once and together.

It remains to add that no training in Social Anthropology can be regarded as complete that does not include the study of the development of language. On the theoretical side of his work the student should acquire a general acquaintance with the principles of comparative philology, and, in particular, should pay attention to the relations between speech and thought. On the practical side he should be instructed in phonetics as a preparation for linguistic researches in the field. But detailed instruction in particular languages, more especially if these are not embodied in a literature, is hardly the business of a School of Anthropology such as every University may aspire to possess. For this reason I welcome whole-heartedly the creation of the London School of Oriental Studies, which obtained its charter of incorporation only some three months ago. It is probably sufficient for the practical needs of the Empire that the teaching of the chief vernacular languages of the East and of Africa, when the object sought is primarily their colloquial use, should be concentrated in a single institution, and this may appropriately have its place in the metropolis. The new School likewise proposes to give instruction not only in the literature (where there is a literature), but also in the history, religion, and customs of the peoples whose languages are being studied. I do not speak with any intimate knowledge of the full scheme contemplated, but would venture to suggest that, if this additional task is to be adequately discharged, the new institution must be organised on a twofold basis, comprising a School of Anthropology with a specially trained staff of its own by the side of the school of languages, whether these be living or classical. If, on the other hand, the study of customs were to be subordinated to the study of languages, being carried out under teachers selected mainly for their linguistic attainments, I fear that this part of the training would prove little better than a sham. Fortunately the University of London already possesses a School of Anthropology, which under the guidance of an exceptionally brilliant staff has already done work which we all know and appreciate. Other Universities, too, have similar schools, and could not acquiesce in the centralisation of anthropological studies in London, least of all in connection with an organisation that is primarily concerned with the teaching of languages. But I have no doubt that a just and satisfactory co-ordination of functions can be arranged between the different interests concerned; and, in the meantime, we, as anthropologists, can have nothing but hearty praise for the enterprise that has endowed with actuality the magnificent and truly imperial idea represented by this new School.

So much, then, for the multiplicity which an anthropological curriculum must involve if it consist, as has been suggested, of Physical Anthropology, Technology with Prehistoric Archæology, and Social Anthropology with Linguistics. And now what of its unity? How best can these diverse studies be directed to a common end? I would submit that there are two ways in which the student may most readily be made to realise the scope of Anthropology as a whole, the one way having reference to theory and the other to practice.

The theoretical way of making it plain that the special studies among which the student divides his time can and must serve a single scientific purpose is to make his work culminate in the determination of problems concerning the movement of peoples and the diffusion of culture—in a word, of ethnological problems (if, as is most convenient, the term 'ethnology' be taken to signify

the theory of the development of the various ethnic groups or 'peoples' of the world). A great impetus was given to the investigation of such matters by Dr. Rivers in a now famous Presidential Address to this Section, followed up as it was shortly afterwards by a monumental work on the ethnology of the Pacific region. But it would be quite a mistake to suppose that anthropologists were not previously alive to the importance of the ethnological point of view as a unifying interest in anthropological theory. As far back as 1891, when the second Folklore Congress met in London under the presidency of the late Andrew Lang, the burning question was how far a theory of diffusion and how far a theory of independent origins would take us in the explanation of the facts with which the science of folklore is more particularly concerned. It is true that there has been in the past a tendency to describe the theory of independent origins as the 'anthropological' argument; but such a misnomer is much to be regretted. Anthropology stands not for this line of explanation or for that, but for the truth by whatever way it is reached; and Ethnology, in the sense that I have given to the term, is so far from constituting the antithesis of Anthropology that it is rather, as I have tried to show, its final outcome and consummation. Recognising this, the Oxford School of Anthropology from the first insisted that candidates for the Diploma should face an examination-paper in Ethnology, in which they must bring the various kinds of evidence derived from physical type, from arts, from customs, and from language to bear at once on the problem how the various ethnic individualities have been formed. The result, I think, has been that our students have all along recognised, even when most deeply immersed in one or other of their special studies, a centripetal tendency, an orientation towards a common scientific purpose, that has saved them from one-sidedness, and kept them loyal to the interests of Anthropology as a whole. Let me add that, as our anthropological course ends in Ethnology, so it begins in Ethnography, by which I mean the descriptive account of the various peoples considered mainly in their relation to their geographical environment. Thus, from the beginning to the end of his work, the student of Anthropology is reminded that he is trying to deal with the varieties of human life in the concrete. He must first make acquaintance with the peoples of the world in their unanalysed diversity, must next proceed to the separate consideration of the universal constituent aspects of their life, and then finally must return to a concrete study of these peoples in order to explain, as well as he can, from every abstract point of view at once how they have come to be what they are. If this theoretical path be pursued, I have little fear lest Anthropology appear to the man who has really given his mind to it a thing of rags and tatters.

The second way in which the unity of Anthropology may be made manifest is, as I have said, practical. The ideal University course in Anthropology should aim directly and even primarily at producing the field-worker. I cannot go here into the question whether better work is done in the field by large expeditions or by small. For educational purposes, however, I would have every student imagine that he is about to proceed on an anthropological expedition by himself. Every part of his work will gain in actuality if he thinks of it as something likely to be of practical service hereafter; and, to judge from my own experience as a teacher, the presence in a class of even a few ardent spirits who are about to enter the field, or, better still, have already had field-experience and are equipping themselves for further efforts, proves infinitely inspiring alike to the class and to the teacher himself. Once the future campaigner realises that he must prepare himself so as to be able to collect and interpret any kind of evidence of anthropological value that he comes across, he is bound to acquire in a practical way and as it were instinctively a comprehensive grasp of the subject, such as cannot fail to reinforce the demand for correlation and unification that comes from the side of theory.

Let me at this point interpolate the remark that recruits for anthropological field-service are to be sought among women students no less than among men. We shall have an opportunity during the present meeting of congratulating Miss Freire-Marreco, Miss Czaplicka, and Mrs. Scoresby Routledge—all members of the Oxford School—on the courage with which they have braved all sorts of risks in order that anthropological science might be

increased. After all, Anthropology is the science of man in the sense that includes woman; and the woman's side of human life, more especially among primitive folk, must always remain inaccessible to the mere male. I hope that our Universities will give this fact due weight, not only when forming their anthropological classes, but also when constituting their teaching staffs. For the rest, even those who for one reason or another are unable to obey 'the call of the wild' may find plenty to do in the way of field-research in the nearest village; and my experience of the work of women, whether as collectors of folklore or as searchers after prehistoric objects, has led me to regard them as capable of responding practically to an anthropological education, to the lasting benefit both of science and of themselves.

So far I have insisted on the need of training the anthropologist to be an 'all-round man.' It stands to reason, however, that in the course of such an education special aptitudes will declare themselves; and it is all for the interests of science that the student should later on confine his activities to some particular field or branch of research. The sole danger lies in premature specialisation. Nor will a short and sketchy course of general anthropology suffice as a propædeutic. A whole year of such preliminary study is the minimum I should prescribe, even for the man or woman of graduate standing who is otherwise well grounded. Thus we find at Oxford that the system works well of encouraging students first to take the Diploma Course, for which at least a year's study is required, and then to proceed to a Research Degree such as is awarded for a substantial thesis embodying the results of some special investigation. In this way we try to educate the only type of specialist for which Anthropology has any use—namely, the type that is capable of concentration without narrowness.

So long as the nucleus of the Anthropological School of a University consists in students who devote themselves to the subject as a whole, there can be no objection, I think, to the inclusion of those who, though primarily interested in distinct if allied subjects, desire to study some branch of Anthropology up to a certain point. Thus at Oxford the classes given in the department of Social Anthropology are attended by theologians, philosophers, lawyers, students of the classics, economists, geographers, and so forth; while elsewhere, as, for instance, at Harvard University, medical students, including those who are interested in special subjects such as dentistry, are attracted by the courses in Physical Anthropology. There is all the more to be said for such a hospitable policy on the part of a University School of Anthropology, inasmuch as our subject is one especially suitable for the graduate student; though at Oxford we have thought it wiser not to limit admission to this class of students, simply requiring that all who enter the school shall produce evidence of having already obtained a good general education. Hence, if students proceeding to the Bachelor's degree along one of the ordinary avenues are brought betimes into touch with anthropological teaching, there is all the better chance of gathering them into the fold after graduation. There is also another good reason why a school of Anthropology should open its classes freely to the votaries of other subjects. It thereupon becomes possible to institute a system of give-and-take, whereby the student of Anthropology can in turn obtain the benefit of various courses of instruction dealing with other subjects akin to his own. Thus at Oxford the School of Anthropology is able to indicate in its terminal lecture-list a large number of sources whence supplementary instruction is forthcoming such as will serve to broaden the student's mind by making him aware of the larger implications of the science of man.

I have been speaking all along as if general education and scientific research were the only objects which a University should keep in view. But I have explained that my sole reason for not discussing education on its technical side was because Sir Richard Temple has already discoursed so weightily on the need for an Applied Anthropology. I should like, however, to submit a few observations concerning this matter. We have had some experience at Oxford in the anthropological training of officers for the public services. The Sudan Probationers, by arrangement with the Governor-General of the Sudan, have received systematic instruction in Anthropology for a number of years.

Again, members of the University and others serving or about to serve in Africa have more recently attended our classes in considerable numbers, and with the express sanction of the Colonial Office. If the Indian probationers have so far had less to do with Anthropology, it is simply because the programme of studies which they are expected to carry out within the space of a year is already so vast. The following are some of the impressions I have formed as to the most suitable way of training students of this type. In the first place, each set of officers destined for a particular province should be provided with a course in the ethnography of their special region. In the second place, all alike should be encouraged to attend some of the general courses provided by the School, if only in order that they may associate with the regular students, and so gain insight into the scientific possibilities of the subject. Thirdly, such official students ought not to be subjected to any test-examination in Anthropology at the end of their course, unless they elect on their own account to enter for the ordinary examinations of the School. We need to deal somewhat tenderly with these men who, after many years of University training, are about to go out into the world; for it is fatal to send them out tired. For this reason, among others, I am in favour of every University retaining its own *alumni* during their probationary period. By this time they are thoroughly at home in their own University; and nowhere else are they likely to be treated with so much consideration as regards their spiritual needs. I am sure that the picked University man who stands on the threshold of a public career can be trusted to make the most of his time of training, if he be not badgered with too many set courses and examinations, but is allowed, under discreet supervision, to follow the promptings of his own common sense. Certainly, in regard to Anthropology, it has answered well at Oxford not to press students of this class too hard. If they have shown keenness at the time, and have done much good work afterwards, it is at least partly because there were no associations of the prison-house to mar their appreciation of the intrinsic interest of the subject.

Though I have indulged in a somewhat lengthy disquisition, I fear that I have not done justice to many aspects of my theme. But I feel less compunction on this score inasmuch as I believe that we who belong to this Section are in close agreement as to the importance of Anthropology as an element in University education, and likewise as to the principles according to which it ought to be taught as an academic subject. The difficulty is rather to make the public realise the need for the fuller encouragement of anthropological studies. Fortunately for the future of our science, Anthropology is an imperial necessity. Moreover, at this crisis in its fortunes, the country is likely to pay heed to the sound maxim that national education must issue in activities of a practical and useful nature; so let us by all means place the practical argument in the forefront of our case. Sir Richard Temple has set us an excellent example in this respect. The contention, however, which I have now to put forward by way of supplement is this, that in order to be practical one must first of all be scientific. In other words, an Applied Anthropology is bound to be a hollow mockery unless it be the outcome of a Pure or Theoretical Anthropology pursued in accordance with the ideal of truth for truth's sake. Nowhere, I believe, so well as within our Universities is it possible to realise the conditions favourable to the study of Anthropology in its practical and imperial bearing; for nowhere else ought the spirit of research to be more at home.

The conclusion, then, of the whole matter is that, for practical and scientific reasons alike, our Universities must endow Schools of Anthropology on a liberal scale, providing funds not only for the needs of teaching, but likewise for the needs of research. Money may be hard to get, but nevertheless it can be got. We must not hesitate, as organisers of education, to cultivate the predatory instincts. For the rest, it is simply a question of rousing public opinion in respect to a matter of truly national importance. If anything that I have said to-day can help in any way to improve the position of Anthropology among University studies, I shall be satisfied that, trite as my subject may have seemed to be, I have not misused the great opportunity afforded to every holder of my present office.

## WEDNESDAY, SEPTEMBER 6.

The following Papers were received :—

1. *Magic and Religion.*<sup>1</sup> By Dr. F. B. JEVONS.

---

2. *The Origin of the Actor.*<sup>2</sup> By Professor W. RIDGEWAY, F.B.A.

---

3. *Is the British Facial Type Changing?*<sup>3</sup>  
By Professor A. KEITH, F.R.S.

---

4. *The Evolution of the (Weaving) Spool and Shuttle.*  
By H. LING ROTH.

---

5. *The Anthropometric Characters of Asylum and Normal Population.*  
By Dr. J. F. TOCHER.

---

6. *Some Beliefs and Customs of the Aborigines of the Malay States.*  
By J. A. N. EVANS.

---

7. *Megalithic Remains on Easter Island.* By SCORESBY ROUTLEDGE.

---

8. *The Roman Wall.* By Professor HAVERFIELD.

---

9. *Monuments of the Early Christian Type in Northumbria.*  
By W. G. COLLINGWOOD.

## THURSDAY, SEPTEMBER 7.

The Section joined the Cumberland and Westmorland Antiquarian and Archæological Association in an Archæological Field Day.

## FRIDAY, SEPTEMBER 8.

After the President had delivered his Address (p. 458) the following Papers and Report were received :—

1. *The Main Cultures of New Guinea.* By Dr. A. C. HADDON, F.R.S.

---

2. *The Cultivation of Taro.*<sup>4</sup> By Dr. W. H. R. RIVERS, F.R.S.

<sup>1</sup> To be published in full in *Folk Lore*.

<sup>2</sup> See Professor Ridgeway's *Dramas and Dramatic Dances of Non-European Races, with special reference to the Origin of Tragedy*. (Cambridge, 1915.)

<sup>3</sup> To be published in full in the *Journ. R. Anthropol. Inst.*

<sup>4</sup> Published in *Proc. Lit. and Phil. Soc. Manchester*.

3. *Transpacific Migrations.* By Dr. A. HRDLICKA.

4. *Recent Archæological Discoveries in the Channel Islands.*<sup>5</sup>  
By Dr. R. R. MARETT.

5. *Organisations of Witches in Great Britain.*<sup>6</sup> By Miss M. MURRAY.

6. *A Summer and Winter among the Tribes of Arctic Siberia.*<sup>7</sup>  
By Miss CZAPLICKA.

7. *Report on the Artificial Islands in the Lochs of the Highlands of Scotland.*—See Reports, p. 303.

8. *Excavation Work on the Artificial Island of Loch Kinellan, Strathpeffer.* By H. A. FRASER. See Reports, p. 303.

SATURDAY, SEPTEMBER 9.

The following Papers were received :—

1. *A Contribution to the Study of the Physical Type of the North-Western Tungus.*<sup>8</sup> By Miss CZAPLICKA.

2. *Recent Culture on Easter Island and its Relation to Past History.*  
By Mrs. SCORESBY ROUTLEDGE.

3. *Personal Experience as an Element in Folk Tales.*  
By Miss B. FREIRE MARRECO.

4. *The Witton Gilbert Stone Axe.* By Rev. ARTHUR WATTS.

<sup>5</sup> See 'Report of Committee for the Excavation of a Palæolithic Site in Jersey' on p. 292 of present volume; *Bulletins de la Société Jersiaise*, 1915, 1916, 1917; and especially *Archæologia*, lxxvii. (1916), 75-118, 'The Site, Fauna, and Industry of La Côte de St. Brelade, Jersey.' By R. R. Marett.

<sup>6</sup> To be published in *Folk Lore*.

<sup>7</sup> Published in full in *Man*, September 1916.

<sup>8</sup> Published in *Man*, September 1916.

## SECTION I.—PHYSIOLOGY.

PRESIDENT OF THE SECTION: PROFESSOR A. R. CUSHNY, M.A.,  
M.D., F.R.S.

---

WEDNESDAY, SEPTEMBER 6.

The President delivered the following Address:—

*On the Analysis of Living Matter through its Reactions to Poisons.*

I AM told that the chair of Section I has not been held by a pharmacologist for many years, and I wish to express the pleasure I feel in the honour that has been done me personally, and even more in the recognition vouchsafed to one of the youngest handmaidens of medicine. Pharmacology has too often shared the fate of the bat in the fable: when we appeal for support to the clinicians we are told that we represent an experimental science, while when we attempt to ally ourselves with the physiologists we are sometimes given the cold shoulder as smacking too much of the clinic. As a matter of fact, we should have a footing in each camp, or, rather, in each division of the allied forces. And the more recent successes in the application of pharmacology to diseased conditions are now beginning to gain it a rather grudging recognition from clinicians, while the alliance with the biological sciences is being knit ever more closely. The effect of chemical agents in the living tissues has assumed a new and sinister aspect since the enemy has resorted to the wholesale use of poisons against our troops, but I must leave this for the discussion to-morrow.

I wish to-day to discuss an aspect of pharmacological investigation which has not been adequately recognised even by the pharmacologists themselves and which it is difficult to express in few words. In recent years great advances have been made in the chemical examination of the complex substances which make up the living organism, and still greater harvests are promised from these analytic methods in the future. But our progress so far shows that, while general principles may be reached in this way, the chemistry of the living organ, like the rainbow's end, ever seems as distant as before. And, indeed, it is apparent that the chemistry of each cell, while possessing general resemblances, must differ in detail as long as the cell is alive. No chemistry dealing in grammes, nor even microchemistry dealing in milligrammes, will help us here. We must devise a technique dealing with millionths to advance towards the living organism. Here I like to think that our work in pharmacology may perhaps contribute its mite; perhaps the action of our drugs and poisons may be regarded as a sort of qualitative chemistry of living matter. For chemical investigation has very often started from the observation of some qualitative reaction, and not infrequently a good many properties of a new substance have been determined long before it has been possible to isolate it completely and to complete its analysis. For example, the substance known now as tryptophane was known to occur in certain substances and not in others long before Hopkins succeeded in presenting it in pure form. And in the same way it may be possible to determine the presence or absence of substances in living tissues, and even some of their properties, through their reaction to chemical reagents,



that is, through the study of the pharmacology of these tissues. A simple example may render the point clearer: It is possible that, if the toxicity of the saponins to different cells were accurately known, the relative importance of the lecithins in the life of these cells might be estimated, and this might give a hint to the chemist in approaching their analysis. I do not claim that pharmacological investigation can at present do much more than the qualitative testing of the tyro in the chemical laboratory, but even a small advance in the chemistry of living matter is worthy of more attention than this has received hitherto.

All forms of living matter to which they have free access are affected by certain poisons, and some of these have obvious chemical properties which suggest the method of their action; thus the effects of alkalies and acids and of protein precipitants hardly need discussion. Others, such as quinine and prussic acid, which also affect most living tissues, have a more subtle action. Here it is believed that the common factor in living matter which is changed by these poisons is the ferments, and quinine and prussic acid may therefore be regarded as qualitative tests for the presence of some ferments, notably those of oxidation, and, in fact, have been used to determine whether a change is fermentative in character or not. Formaldehyde was stated by Loew to be poisonous to living matter through its great affinity for the  $\text{NH}_2$  group in the proteins, a suggestion which has perhaps not received enough attention of late years, during which the importance of this group in proteins has been demonstrated. The toxicity of other general poisons, such as cocaine, is more obscure. But what has been gained already in this direction encourages further investigation of the action of the so-called general protoplasm poisons, and further efforts to associate it with the special constituents of the cell.

In other poisons the action on the central nervous system is the dominating feature, and among these the most interesting group is that of the simple bodies used as anæsthetics and hypnotics, such as ether, chloroform, and chloral. The important use of this group in practical medicine has perhaps obscured the fact that they act on other tissues besides the central nervous system, though we are reminded of it at too frequent intervals by accidents from anæsthesia. But while they possess this general action, that on the nervous tissues is elicited more readily. Not only the nerve-cell, but also the nerve-fibre, react to these poisons, as has been shown by Waller and others. And even the terminations are more susceptible than the tissues in which they are embedded, according to the observations of Gros. The selective action on the nervous tissues of this group of substances has been ascribed by Overton and Meyer to the richness in lipid substances in the neurons, which leads to the accumulation of these poisons in them, while cells containing a lower proportion of lipid are less affected. In other words, Overton and Meyer regard these drugs as a means of measuring the proportion of lipoids in the living cell. This very interesting view has been the subject of much discussion in recent years, and, in spite of the support given it by several ingenious series of experiments by Meyer and his associates, no longer receives general acceptance. Too many exceptions to the rule have to be explained before the action of these bodies can be attributed wholly to their coefficients of partition between lipoids and water. At the same time the evidence is sufficient to justify the statement that the property of leaving water for lipid is an important factor in the action of the bodies, although other unknown properties are also involved in it. And whatever the mechanism of the characteristic action, these substances in certain concentrations may be regarded as tests for the presence of nervous structures and have been employed for this purpose.

Other bodies acting on the nervous system have a much narrower sphere. Morphine and strychnine, for example, appear to be limited to the region of the nerve-cells, but there is still doubt whether they affect the cell-body alone or the synapses between certain of its processes. They have not been shown to act on peripheral nervous structures in vertebrates, nor on any but specific regions of the central nervous system. Nor has it been established that they affect invertebrates. The substance with which they react is obviously limited by very narrow boundaries around the nerve-cell.

More interest has been displayed in recent years in the alkaloids which act on the extreme terminations of various groups of nerves. These are among

the most specific reagents for certain forms of living matter which we possess. Thus, if an organ reacts to adrenalin, we can infer that it contains the substance characteristic of the terminations of sympathetic fibres, with almost as great certainty as we infer the presence of a phenol group from the reaction with iron. And this sympathetic substance can be further analysed into two parts by means of ergotoxine, which reacts with the substance of the motor sympathetic ends, while leaving that of the inhibitory terminations unaffected. Similarly the endings of the parasympathetic nerves are picked out with some exceptions by the groups represented by atropine and pilocarpine, and here again there must be some definite substance which can be detected by these reagents.

Further, some light has been thrown on, at any rate, one aspect of these nerve-end substances by the observation that they all react to only one optical isomer in each case. Thus the dextro-rotatory forms are ineffective in both atropine and adrenalin, and this suggests strongly that the reacting body in the nerve-ends affected by these is itself optically active, though whether it bears the same sign as the alkaloid is unknown. This very definite differentiation between two optical isomers is not characteristic of all forms of living matter. For example, the heart muscle seems to react equally to both lævo- and dextro-camphor. The central nervous system contains substances which react somewhat differently to the isomers of camphor and also of atropine, but the contrast is not drawn so sharply as that in the peripheral nerve-ends.

Another test alkaloid is curarine, the active principle of curare, which in certain concentrations selects the terminations of the motor nerves in striated muscle as definitely as any chemical test applied to determine the presence or absence of a metal.

The tyro in the chemical laboratory is not often fortunate enough to be able to determine his analysis with a single test. He finds, for example, that the addition of ammonium sulphide precipitates a considerable group of metals, which have then to be distinguished by a series of secondary reactions. The pharmacologist, as an explorer in the analysis of living matter, also finds that a single poison may affect a number of structures which appear to have no anatomical or physiological character in common. But as the chemist recognises that the group of metals which react in the same way to his reagent have other points of resemblance, so perhaps we are justified in considering that the effects of our poison on apparently different organs indicate the presence of some substance or of related substances in them. A great number of instances of this kind could be given, and in many of these the similarity in reaction extends over a number of poisons, which strengthens the view that the different organs involved have some common reacting substance.

One of the most interesting of these is the common reaction of the ends of the motor nerves in striated muscle and of the peripheral ganglia of the autonomic system. It has long been known that curare and its allies act in small quantities on the terminations of the motor nerves in ordinary muscle, while larger amounts paralyse conduction through the autonomic ganglia. More recently it has been developed by the researches of Langley that nicotine and its allies, acting in small quantities on the ganglia, extend their activities to the motor-ends in large doses. Some drugs occupy intermediate positions between nicotine and curare, so that it becomes difficult to assign them to either group. These observations appear to leave no question that there is some substance or aggregate common to the nerve-ends in striated muscle and to the autonomic ganglia. As to the exact anatomical position of this substance, there is still some difference of opinion. Formerly it was localised in the terminations of the nervous fibres in the muscle and ganglia, but Langley has shown that in the latter the point of action lies in the ganglion-cell itself, and his researches on the antagonism of nicotine and curare in muscle appear to show that the reacting substance lies more peripherally than was supposed, perhaps midway between the anatomical termination of the nerve and the actual contractile substance. Another analogy in reaction has been shown to exist between the ganglia and the terminations of the post-ganglionic fibres of the parasympathetic, for Marshall and Dale have pointed out that a series of substances, such as tetramethyl-ammonium, affect each of these in varying degrees of intensity. The specific character of the reaction is shown by the

fact that while it is possessed by the tetramethyl-ammonium salts, the tetraethyl-ammonium homologues are entirely devoid of it.

Another close relationship is shown by the reaction of the glucosides of the digitalis series on the heart and vessels. These all act on the muscle of the heart, and in higher concentration on that of the vessel-walls. There must therefore be a common base in these which is affected by the drugs. And the existence of this is perfectly intelligible in view of the fact that the heart is developed from the vessels. A more obscure relationship is shown by the reaction of this group to the inhibitory cardiac centre in the medulla, which is thrown into abnormal activity by their presence in the blood, as has been shown alike by clinical and experimental observations. A similar relation is shown by the common reaction of the heart-muscle and the vagus centre to aconitine and some other related alkaloids. On the other hand, the saponin series, which shows a closer relationship to the digitalis bodies in the heart-muscle, is devoid of its characteristic action on the medulla. The reacting substance in the heart is thus capable of responding to digitalis, saponin and aconitine, while that in the vagus centre can associate only the first and last and is not affected by the saponins; the common reactions indicate that the two are related, while the distinctive effect of saponin shows that they are not identical. A similar relationship may be drawn from the action of morphine and the other opium alkaloids on pain sensation, on respiration, and on the movements of the alimentary tract. Exact determinations of the relative power of these alkaloids in these regions are not at our disposal as yet, but sufficient is known to suggest that while morphine affects a common substance in the medullary centre and the intestinal wall, the other members of the series act more strongly in one or other position.

It was long ago pointed out that caffeine affects both kidney and muscle-cell, and Schmiedeberg has attempted to correlate the intensity of action of the purine bodies at these points and to measure the probable diuretic action by the actually observed effect on the contraction of muscle. Other reactions of the kidney suggest a relationship to the wall of the bowel. For example, many of the heavy metals and some other irritant bodies act strongly on the kidney and bowel, and again, according to one view of renal function, many of the simple salts of the alkalies affect the kidney in exactly the same way as the bowel-wall. This last may, however, be due to the physical properties of the salts, and the likeness in reaction to those of kidney and bowel, which is striking enough, may arise rather from a likeness in function of the epithelium rather than from any specific relationship to the salts which is not common to other forms of living matter.

Many other examples might be cited in which organs which are apparently not related, either morphologically or in function, react to poisons in quantities which are indifferent to the tissues in general. And this reaction in common can only be interpreted to mean that there is some substance or group of related substances common to these organs. The reaction may differ in character; thus a drug which excites one organ to greater activity may depress another, but the fact that it has any effect whatever on these organs in preference to the tissues in general indicates some special bond between them, some quality which is not shared by the unaffected parts of the body. I have, therefore, not differentiated between excitation and depression in discussing this relation. One is tempted to utilise the nomenclature introduced by Ehrlich here, and to state that the common reaction is due to the presence of haptophore groups while the nature of the reaction (excitation or depression) depends on the character of the toxophore groups. But while these terms may be convenient when applied to poisons whose chemical composition is altogether unknown, they merely lead to confusion when the question concerns substances of ascertained structure. Thus, as Dale has pointed out, it is impossible to suppose that such substances as tetramethyl-ammonium and tetraethyl-ammonium owe the difference in reactions to specific haptophore groups in the one which are absent in the other. It seems more probable that in this instance and in others the difference in the effect of these bodies in the tissues arises from differences in the behaviour of the molecule as a whole than in differences in the affinities of its special parts; that is, that the action of these poisons is due to their physical properties rather than to their chemical structure, although this, of course, is the final determining cause.

In the same way the common reaction of tissues, which I have so far ascribed to their possessing some substance in common, may arise from community of physical relationship, and I wish to avoid the implication borne by the word 'substance,' which I have used in the widest sense, such as is justified perhaps only by its historical employment in theological or philosophical controversy. The reaction of living tissue to chemical agents may arise from a specific arrangement in its molecule, but may equally be attributed to the arrangement of the molecules themselves. And the curious relationships in the reactions of different tissues may indicate, not any common chemical factor, but a common arrangement of the aggregate molecules. We are far from being able to decide with even a show of probability which of these alternatives is the correct one, and my object to-day has been to draw attention to these relationships rather than to attempt their elucidation. Hitherto the speculative pharmacologist has been much engaged in comparing the chemical relationship of the drugs which he applies to living tissues; much useful knowledge has been incidentally acquired, and the law has been formulated that pharmacological action depends directly on, and can be deduced from, chemical structure. This view, first elaborated in this country, has in recent years shared the fate of other English products in being advertised from the housetops and practically claimed as the discovery of more vociferous investigators. On examining the evidence, old and new, one cannot help feeling that attention has been too much directed to those instances which conform to the creed, while the far more numerous cases have been ignored in which this so-called rule fails. The difficulties are very great; for example, what chemical considerations can be adduced to explain why the central nervous tissues react differently to bromide and chloride, while to the other tissues these are almost equally indifferent; or how can the known chemical differences between potassium and sodium be brought into relation with the fact that they differ in their effects in almost every form of living tissue?

Less attention has been paid to the other factor in the reaction, the properties of the living tissue which lead one cell to react to a poison, while another fails to do so. I have pointed out some curious relations between different organs, but much needs to be done before any general view can be obtained. Further detailed examination of the exact point at which poisons act, and much greater knowledge of the physical characters of the drugs themselves and of the relation of colloid substances to these characters, are needed. We must attempt to classify living tissues in groups not determined by their morphological or even functional characters, but by their ability to react to chemical agents. Advance is slow, but it is continuous, and if no general attack on the problem is possible as yet, our pickets are at any rate beginning to give us information as to the position of the different groups to be attacked. And when a sufficient number of these qualitative reactions have been ascertained for any form of living matter, it may be possible for some Darwin to build a bridge from the structural chemistry of the protein molecule to the reactions of the living cell. We can only shape the bricks and mix the mortar for him. And my purpose to-day has been to indicate how the study of the effects of drugs on the living tissue may also contribute its mite towards the great end.

---

The following Reports and Papers were then received :—

1. *Report on the Ductless Glands.*—See Reports, p. 305.

---

2. *Report on the Structure and Function of the Mammalian Heart.*  
See Reports, p. 304.

---

3. *Report on the Significance of the Electromotive Phenomena of the Heart.*

---

4. *Report on Electromotive Phenomena in Plants.*

See Reports, p. 305.

5. *Report on Anæsthetics.*6. *The Effect of Pituitary Extract on the Secretion of Cerebro-spinal Fluid.*<sup>1</sup> By Professor W. D. HALLIBURTON, F.R.S.

## THURSDAY, SEPTEMBER 7.

The following Papers were received :—

1. *Arginine and Creatine Formation (further investigations).*  
By Professor W. H. THOMPSON, M.D.2. *The Secretion of Urea and Sugar by the Kidney.*<sup>2</sup>  
By Professor A. R. CUSHNY, F.R.S.3. *The Action of Thyroid on the Suprarenals and Heart.*  
By Professor P. T. HERRING, M.D.4. *The Effect of Thyroid-feeding on the Pancreas.*<sup>3</sup> By Dr. KOJIMA.

## FRIDAY, SEPTEMBER 8.

Joint Discussion with Sub-Section I and Section L on the Report on the Mental and Physical Factors involved in Education (p. 307).

The following Papers were then received :—

1. *The Action of Ovarian Extracts.* By Dr. ITAGAKI.2. *The Properties required in Solutions for Intravenous Injections.*<sup>4</sup>  
By Professor W. M. BAYLISS, F.R.S.3. *Food Standards and Man-Power.*  
By Dr. A. D. WALLER, F.R.S.4. *The Nutrition of Living Organisms by Simple Organic Compounds.*  
By Professor B. MOORE, F.R.S., and J. E. BARNARD.<sup>1</sup> See Halliburton, W. D., and Dixon, W. E., *Journ. of Physiology*, vol. 1., pp. 198-216, 1916.<sup>2</sup> To be published in full in *Journal of Physiology*, vol. II.<sup>3</sup> Published in full in the *Quarterly Journal of Experimental Physiology*.<sup>4</sup> See 'Methods of Raising a Low Arterial Pressure,' *Proc. Roy. Soc. B.* 89, p. 381.

## SUB-SECTION OF PSYCHOLOGY.

WEDNESDAY, SEPTEMBER 6.

The following Papers and Report were received :—

1. *Experiments upon the Effectiveness of War-Economy Posters.*<sup>5</sup>  
By Miss EDGELL.

---

2. *An Investigation of London Children's Ideas as to how they can help in Time of War.*<sup>6</sup> By Dr. C. W. KIMMINS.

---

3. *Report on the Organisation of Research into Psychological Problems arising out of the War.*

THURSDAY, SEPTEMBER 7.

The following Papers were received :—

1. *Some Notes on the Concept of Instinct.* By Professor NUNN, M.A.

---

2. *Emotional Disturbances from a Biological Point of View.*  
By Dr. MURRAY.

---

3. *Some Aspects of Infancy and Childhood in the Light of Freudian Principles.* By Miss TURNER.

FRIDAY, SEPTEMBER 8.

*Joint Discussion with Sections I and L on the Report on the Mental and Physical Factors involved in Education (p. 307). Opened by Professor J. A. GREEN, M.A.*

The following Papers were then read :—

1. *Sociology and Psychology.*<sup>7</sup> By Dr. W. H. R. RIVERS, F.R.S.

---

2. *Psychological Research and Race Regeneration.* By Dr. ABELSON.

<sup>5</sup> See *The Government as Advertiser* in the *Sociological Review*.

<sup>6</sup> To be published in the *Journal of Experimental Pedagogy*, March 1917.

<sup>7</sup> Published in full in the *Sociological Review*.

## SECTION K.—BOTANY.

PRESIDENT OF THE SECTION: A. B. RENDLE, M.A., D.Sc., F.R.S.

WEDNESDAY, SEPTEMBER 6.

The President delivered the following Address:—

SINCE our last meeting the Great War has continued to hold chief place in our lives and thoughts, and in various ways, and to a greater or less degree, has influenced our work. In the case of many Botany has had for the time being to be set aside, while others have been able to devote only a part of their time to scientific work. On the other hand, it is gratifying to note that some have been able to render helpful service on lines more or less directly connected with their own science. The trained botanist has shown that he may be an eminently adaptable person, capable, after short preparation on special lines, of taking up positions involving scientific investigation of the highest importance from the standpoints of medicine and hygiene.

We have to regret the loss of a promising young Cambridge botanist, Alfred Stanley Marsh, who has made the supreme sacrifice for his country. Happily, in other cases lives have been spared and we are able to welcome their return to the service of botany.

In common with our fellow-botanists throughout the world, we have learnt with sorrow of the death of one of the kindest and most versatile exponents of the science, Count Solms-Laubach, whom we have welcomed in years past as a guest of our Section.

May I also refer to the recognition recently given by the Royal Society to the services of two of our Colonial botanists?—Mr. J. H. Maiden, of Sydney, who has done so much in Australia for the development of botany and its applications in his position as Government Botanist and Director of the Botanic Gardens at Sydney, and whose kindness some of us have good cause to remember on the occasion of the visit of this Association to Sydney in 1914; and Professor H. H. W. Pearson, of Cape Town, who is doing useful work of botanical exploration in South-West Africa.

A little more than two years ago, during the enforced but pleasant leisure of our passage across the Indian Ocean to Australia, I was discussing with our President for the year the possibility of a war with Germany. He was confident that sooner or later it was bound to come. I was doubtful. 'But what will prevent it?' asked my companion. 'The common sense of the majority,' was my reply. He was right and I was wrong, but I think he was only less surprised than myself when next evening we heard, by wireless, rumours of the outbreak of what rapidly developed into the great European war. But even a few weeks later, when Germany was pressing westwards, and the very existence of our Empire was threatened, we hardly began to appreciate what it would mean, and we still talked of the possibility of an International Botanical Congress in 1915.

We know more now, and I need not apologise for considering in my Address the part which botanists can take in the near future, especially after the war. For one thing at least is certain: we are two years nearer the end than when it began, and let us see to it that we are not as backward in preparing for post-war as we were for war problems.

Some months ago the various Sectional Committees received a request to consider what could be done in their respective Sections to meet problems which would arise after the war. Your Committee met and discussed the matter, with the result that a set of queries was sent round to representative botanists asking that suggestions might be presented for consideration by the Committee. A number of suggestions were received of a very varied kind, indicating that in the opinion of many botanists at any rate much might be done to utilise our science and its trained workers in the interests of the State and Empire. Your Committee decided to arrange for reports to be prepared on several of the more important aspects by members who were specially fitted to discuss these aspects, and these will be presented in the course of the meeting. These reports will, I am convinced, be of great value, and may lead to helpful discussion; they may also open up the way to useful work.

For my own part, while I might have preferred to consider in my Address some subject of more purely botanical interest, I felt that under the circumstances an academic discourse would be out of place, and that I too must endeavour to do something to effect a more cordial understanding between botany and its economic applications.

For many of us this means the breaking of new ground. We have taken up the science because we loved it, and if we have been able to shed any light on its numerous problems the work has brought its own reward. But some of us have on occasion been brought into touch with economic problems, and such must have felt how inadequate was our national equipment for dealing with some of these. In recent years we have made several beginnings, but these beginnings must expand mightily if present and future needs are to be adequately met and if we are determined to make the best use of the material to our hand.

Whether or not we have been living for the past forty years in a fool's paradise, it is certain that our outlook will be widely different after the war, and may the stimulus of a changed environment find us ready to respond!

Sacrifice must be general, and the botanist must do his bit. This need not mean giving up the pursuit of pure science, but it should mean a heavy specialisation in those lines of pure science which will help to alleviate the common burden, will render our country and the Empire less dependent on external aid, and knit more closely its component parts.

It may be convenient to consider, so far as they are separable, Home and Imperial problems.

Without trenching on the domain of Economics, we may assume that increased production of foodstuffs, timber, and other economic products will be desirable. The question has been raised as to the possibility of increasing at the same time industrial and agricultural development. But as in industry perfection of machinery allows a greater output with a diminished number of hands, so in agriculture and horticulture perfection of the machinery of organisation and equipment will have the same result.

There are three factors in which botanists are primarily interested—the plant, the soil, and the worker.

The improvement of the plant from an economic point of view implies the co-operation of the botanist and the plant-breeder. The student of experimental genetics, by directing his work to plants of economic value, is able, with the help of the resources of agriculture and horticulture, to produce forms of greater economic value, kinds best suited to different localities and ranges of climate, those most immune to disease and of the highest food-value. Let the practical man formulate the ideal, and then let the scientist be invited to supply it. Much valuable work has been done on these lines, but there is still plenty of scope for the organised Mendelian study of plants of economic importance. It is a very large subject, and we are hoping to hear more about it before we separate.

A minor example occurs to me. Do the prize vegetables which one sees at shows and portrayed in the catalogues represent the best products from an economic point of view; in other words, is the standard of excellence one which considers solely their value as foodstuffs? A chemico-botanical examination would determine at what point increase in size becomes disproportionate to increase in food-value, and thus correct the standard from an economic point of



view. And, presumably, the various characters which imply greater or less feeding value offer scope for the work of the Mendelian.

The subject of intensive cultivation offers a series of problems which are primarily botanical. It would be a useful piece of investigation to work out the most profitable series which can be grown from year to year with the least expenditure on manures and the minimum of liability to disease. A comparatively small area would suffice for the work.

The introduction of new plants of economic value is within the range of possibility; our *répertoire* has increased in recent years, but an exhaustive study of food plants and possible food plants for man and stock would doubtless yield good results. It is matter of history that the introduction of the tea plant into further India was the result of observations by Fortune, a botanical collector. The scientific botanist may find pleasant relaxation in the smaller problems of horticulture.

We have heard much lately as to the growing of medicinal plants, and experience would indicate that here is opportunity for investigation, and, unless due care is taken, also danger of waste of time, money, and effort. A careful systematic study of species, varieties, and races is in some cases desirable in order to ensure the growth of the most productive or valuable plants, as in the case of the Aconites; and such a study might also reveal useful substitutes or additions. Here the co-operation between the scientific worker and the commercial man is imperative. I have recently been interested to hear that the special properties of medicinal plants are to be subjected to experiment on Mendelian lines.

During the past year there has been considerable activity in the collecting of wild specimens of various species of medicinal value, frequently, one fears, involving loss of time and waste of plants, owing to want of botanical or technical knowledge and lack of organisation. In this connection a useful piece of botanical work has recently been carried out by Mr. W. W. Smith, of Edinburgh, on the collection of sphagnum for the preparation of surgical dressings. The areas within the Edinburgh district have been mapped and classified so as to indicate their respective values in terms of yield of sphagnum. By the indication of the most suitable areas, the suitability depending on extent of area, density of growth, freedom of admixture of grass or heather, as well as facility of transport and provision of labour, the report is of great economic value. The continuity of supply is an important question, and one which should be borne in mind by collectors of medicinal plants generally. And while it is not the most favourable time to voice the claims of protection of wild plants, one may express the hope that the collector's zeal will be accompanied by discretion.

The advantages arising from a closer co-operation between the practical man and the botanist are illustrated by the research laboratories recently organised by the Royal Horticultural Society at Wisley. Such an institution forms a common meeting-ground for the grower of plants and the botanist. The former sets the problems, and the latter takes them in hand under conditions approaching the ideal and with the advantages of mutual discussion and criticism. Institutions such as these will give ample opportunity to the enthusiastic young botanist who is anxious to embark on work of investigation. The student of plant physiology will find here work of great interest. The grower has perforce gained a great deal of information as to the behaviour of his plants under more or less artificial conditions, but he is unable to analyse these conditions, and the co-operation of the physiologist is an invaluable help. Experiments in the growth of plants under the influence of high-tension electricity are at the present time being carried out at Wisley. Such experiments may be conducted anywhere where land and power are available, but it is obviously advantageous that they should be conducted by an expert plant-physiologist versed in scientific method and not directly interested in the result. Dr. Keeble's recent series of lectures on Modern Horticulture at the Royal Institution deal with matter which is full of interest to the botanist. For instance, he shows how the work of Continental botanists on the forcing of plants has indicated methods, in some cases simple and inexpensive, which have proved of considerable commercial value, and that there is evidently scope

for work in this direction, which, while of interest to the plant-physiologist, may be also of general utility.

The subject of the soil offers problems to the botanist as well as to the chemist and proto-zoologist. In the plant we are dealing with a living organism, not a machine; and an adequate knowledge of the organism is essential to a proper study of its nutrition and growth. The facility with which a considerable sum of money was raised just before the war to improve the equipment at Rothamsted, where work was being done on these lines, indicates that practical men are ready to come forward with financial help if work which promises to yield results of economic importance is being seriously carried out. And it is significant of the attitude of botanists to such problems that there is only one trained botanist on the staff of this institution.

The study of manures and their effect on the plant should attract the botanist as well as the chemist. In this connection I may refer to Mr. Martin Sutton's recent work at Reading on the effects of radio-active ores and residues on plant-life. A series of experiments was carried out in two successive years with various subjects selected for the different character of their produce, and including roots, tubers, bulbs, foliage, and fruit. From the immediate point of view of agriculture and horticulture the results were negative; the experiments gave no hope of the successful employment of radium as an aid to either the farmer or gardener. Speaking generally, the produce from a given area was less when the soil had been treated with pure radium bromide, or various proprietary radio-active fertilisers, than when treated with farmyard manure or a complete fertiliser, while the cost of dressing was very much greater. To quote Mr. Sutton's concluding words, 'The door is still open to the investigator in search of a plant fertiliser which will prove superior to farmyard dung or the many excellent artificial preparations now available.' But though the immediate result was unsatisfactory to the grower, there were several points of interest which would have appealed to the botanist who was watching the course of the experiments, and which, if followed up, might throw light on the effect of radium on plant-life and lead in the end to some useful result. As Mr. Sutton points out, many of the results were 'contradictory,' while a close examination of the trial notes, together with the records of weights, will furnish highly interesting problems. For instance, there was evidence in some cases that germination was accelerated by presence of radium, though subsequent growth was retarded; and the fact that in several of the experiments plants dressed with a complete fertiliser in addition to radium have not done so well as those dressed with the fertiliser only may be regarded as corroborating M. Truffaut's suggestion that radium might possess the power of releasing additional nitrogen in the soil for the use of plants, and that the plants in question were suffering from an excess of nitrogen. Certain remarkable variations between the duplicate unmanured control plots in several of the experiments led to the suggestion that radium emanations may have some effect, apparently a beneficial one. I have quoted these experiments as an example of a case where the co-operation of the botanist and the practical man might lead to useful results, and at the same time afford work of much interest to the botanist.

As an introduction to such work, University Professors might encourage their advanced students to spend their long vacation in a large nursery or botanic garden where experimental work is done.

As regards the worker in agriculture and horticulture, how can the botanist help? Apart from well-staffed and well-equipped schools of agriculture and horticulture, which require the botanist's assistance, a wider dissemination of the botanist would be advantageous. Properly trained botanists distributed through the country with their eyes open might be a valuable asset in the improvement of production; botanist and cultivator might be mutually helpful; the former would meet problems at first hand, and the latter should be encouraged by the co-operation. A kind of first-aid class suggests itself, run by a teacher with a good elementary knowledge of botany, upon which has been erected a general knowledge of horticultural operations. This would afford a vocation for students of scientific bent who cannot spare the time for a long University course. Some of us may remember the courses arranged by various County Councils thirty years or so ago, financed by the whisky money, out of

which have grown some useful permanent educational institutions. But these courses were often barren of result, owing partly to insufficient 'sympathy' between the lecturer and his audience. A young man fresh from the University who was waiting for a more permanent job was brought into touch with the practical man in the lecture hall, and the contact was, so to speak, not good. Between the two was a gulf across which the lecturer shouted, and his words often conveyed little meaning to those on the other side. A great deal of money must have been spent with incommensurate results.

On the other hand, we must be careful to work economically and not wear out high-class tools on rough work. I think there is some danger of this in connection with certain courses in horticulture for women. Girls who have had a good general education enter, at the age of seventeen or eighteen, on a course of study, lasting for two or three years, of horticultural methods and the kindred sciences. So far, good; but after all this training the finished product should aspire to something more than market gardening in competition with the man who left school at twelve or fourteen, has learnt his business practically, and has a much lower standard of living.

The utilisation of waste lands is a big subject and trenches on the domain of Economics. But important botanical problems are involved and careful ecological study will prepare the way for serious experimental work. The study of the growth of plants in alien situations is fraught with so many surprises and apparent contradictions that successful results may be looked for in most unlikely situations. I remember a striking instance near Lake Tarawera, in the North Island of New Zealand. The area in question had been completely devastated in the great eruption of Mount Tarawera in 1886, the ground being covered with ash to a depth of several feet. When I saw it two years ago the vegetation of a considerable area was almost purely Central European. The trees were poplar, *Robinia*, and elder, with an undergrowth of dog-rose, bramble, &c. I was not able to find out the recent history of the locality and there were very few signs of habitation, but it was not the kind of vegetation one would expect to find growing so naturally and freely in such a locality. But the subject of utilisation of waste lands will occupy us later.

The study of the diseases to which plants are liable, and their prevention and cure, offers a wide and increasing field for inquiry, and demands a larger supply of trained workers and a more definite and special system of training. For the study of those which are due to fungi it is obviously essential that a thorough general knowledge of fungi and laboratory methods should be acquired, preferably at some Pathological Institution which would also be in touch with the cultivator and naturally approached by those requiring advice and help in connection with disease, on the same principle that a medical school is attached to a hospital. An important part of the training should be the study of the disease in the field and the conditions under which it arises and flourishes. From the point of view of Mycology much useful scientific work remains to be done on the life history of the fungi which are or may be the causes of disease. The study of preventive methods must obviously be carried out in the field, and, while these are mainly mechanical processes, they need careful supervision; the question of the subsequent gathering and disposal of a crop must not be overlooked. Experiments in the use of dust instead of spray as a preventive of fungous and insect attack have recently been carried out in America. Other plant diseases afford problems for the physiologist, who is a necessary part of the equipment of the Pathological Institute.

The anatomical and chemical study of timbers might with advantage occupy a greater number of workers. The matter is of great economic importance. Questions of identity are continually arising, and in the present vague state of our knowledge it is often difficult or impossible to give a satisfactory answer. Samples of timber are put on the market shipped, say, from West Africa under some general name such as mahogany; the importer does not supply leaves and flowers for purpose of identification, and in the present incomplete state of our knowledge it is often impossible to make more than a vague attempt at determination. Or a merchant brings a sample

which has been sent from X as Y, which it obviously is not; but what is it, whence does it probably come, and what supply of it is likely to be forthcoming? These are questions which it would be useful to be able to answer with some greater approach to accuracy than at present. And it should be the work of definitely trained persons. I recall a sample of wood which some months ago, coming from a Government Department, went the round of the various institutions which were at all likely to be able to supply the required information as to its identity. It should have been matter of common knowledge where to apply, with at the same time reasonable certainty of obtaining the information required.

It is possible also that a more systematic study of minute structure would help to solve questions of affinity. A chemical study has proved of value in the discrimination of the species of *Eucalyptus* in Australia.

Apart from co-operation between the botanist and the practical or commercial man, there is need for co-ordination between workers. I give the following incident from real life. At the meeting of an advisory committee the head of a certain institution stated that he had set one of his staff to work at a certain disease which was then under discussion, but had learnt shortly after that a student at another institution was engaged on the same piece of work. A conference led to a useful division, one of the workers to study the life history of the organism in the laboratory, the other to work at conditions of life, &c., in the field. But it also transpired that another institution, as well as another independent worker, were engaged on the same problem, and while it was suggested that in one case co-operation might be invited, it was deemed inadvisable to approach the other. The problem in this case was not one of such special difficulty as to require so much attention, and even if it had been some co-ordination between the various working units would have been helpful. Similar instances will occur to you. The measure of efficiency of our science should be the sum of the efficiency of its workers. It should be possible to devise some means for informing fellow-workers as to the piece of work in hand or proposed to be undertaken, and thus on the one hand to avoid wasteful expenditure of time and effort, and not infrequently the hurried publication of incomplete results, and on the other to ensure where practicable the benefits of co-operation.

The various illustrative suggestions which I have made would imply a close co-operation between the schools of botany and colleges and institutions of agriculture, horticulture, and forestry; to pass from the former to one or other of the latter for special work or training should be a natural thing. While on the one hand a University course is not an essential preliminary to the study of one or other of the applied branches, the advantages of a broad, general training in the principles of the science cannot be gainsaid. The establishment of professorships, readerships, or lectureships in economic botany at the University would supply a useful link between the pure and applied science, while research fellowships or scholarships would be an incentive to investigation.

There is the wider question of a rapprochement between the man of science and the commercial man. Its desirability is obvious, and the advantages would be mutual; on the one hand it would secure the spread and application of the results of research, and on the other hand the man of science would be directed to economic problems of which otherwise he might not become cognisant. The closer association between the academic institution and those devoted to the application of the science would be a step in this direction.

Our British possessions, especially within the tropics, contain a wealth of material of economic value which has been only partially explored. One of the first needs is a tabulation of the material. In the important series of Colonial floras inception by Sir Joseph Hooker, and published under the auspices of Kew, lies the foundation for further work. Consider, for instance, the 'Flora of Tropical Africa,' now rapidly nearing completion. This is a careful and, so far as possible with the material at hand, critical descriptive catalogue of the plants from tropical Africa which are preserved in the great British and European Herbaria. The work has been done by men with considerable training in systematic work, but who know nothing at first hand of the country the vegetation of which they are cataloguing. Such a 'Flora' must be regarded as

a basis for further work. Its study will indicate botanical areas and their characteristics, and suggest what areas are likely to prove of greater or less economic value, and on what special lines. It will also indicate the lines on which areas may be mapped out for more detailed botanical exploration. That this is necessary is obvious to any botanist who has used such a work. A large proportion of the species, some of which may, on further investigation, prove to be of economic value, are known only from a single incomplete fragment. Others, for instance, which may be of known economic value, doubtless exist over much larger areas and in much greater quantity than would appear from the 'Flora.' The reason of these shortcomings is equally obvious. The collections on which the work is based are largely the result of voluntary effort employed more or less spasmodically. The explorer working out some new route, who brings what he can conveniently carry to illustrate the plant products of the new country; the Government official or his wife, working during their brief leisure or collecting on the track between their different stations; the missionary or soldier, with a penchant for natural history; to these and similar persons we are largely indebted for additions to our knowledge of the plant-life. Advantage has sometimes been taken of a Government expedition to which a medical man with a knowledge of or taste for natural history, or, in rare cases, a trained botanist, has been attached.

The specimens brought home by the amateur collector often leave much to be desired, and little or no information is given as to precise locality or the nature of the locality, the habit of the plant, or other items of importance or interest. There may be indications that the plant is of economic value, but no information as to whether it is rare or plentiful, local or occurring over a wide area.

Samples of wood are often brought, but generally without any means of identification except a native name; and it must be borne in mind that native names are apt to be misleading; they may be invented on the spur of the moment to satisfy the white man's craving for information or when genuine are often applied to more than one species.

A large proportion of the more extensive collections are due to German enterprise, and the best representation of this work is naturally to be found in Germany, though it is only fair to state that the German botanists have been generous in lending material for work or comparison. The botanical investigation of German East Africa and the Cameroons has been carried out by well-trained botanists and collectors, and the results of their work published both from botanical and economic points of view. I may refer to the large volume on German East Africa, which contains not only a general account of the vegetation and a systematic list of the genera and species comprising the flora, but also an account of the plants of economic value classified according to their uses. The exploration of the Belgian Congo has been seriously undertaken by the Belgian Government, and a number of large and extensively illustrated botanical memoirs have been issued. Some of us may be familiar with the fine Congo Museum near Brussels.

It is time that pioneer work gave place to systematic botanical exploration of our tropical possessions and the preparation of handy working floras and economic handbooks. Work of botanical exploration should be full of interest to the young botanist. But if he is to make the best use of time and opportunity he must have had a proper course of training. After completing his general botanical course, which should naturally include an introduction to the principles of classification, he should work for a time in a large Herbarium and thus acquire a knowledge of the details of systematic work and also of the general outlines of the flora of the area which he is to visit later. He should then be given a definite piece of work in the botanical survey of the area. From the collated results of such work convenient handbooks on the botanical resources of regions open to British enterprise could be compiled. There will be plenty of work for the systematist who cannot leave home. The ultimate elaboration of the floristic work must be done in the Herbarium with its associated library. There is also need of a careful monographic study of genera of economic value which would be best done by the experienced systematist at home, given a plentiful supply of carefully collected and annotated material. An example of such is the systematic

account of the species of *Sansevieria* by Mr. N. E. Brown, recently issued at Kew. Closely allied species or varieties of one and the same species may differ greatly in economic value, and the work of the monographer is to discover and diagnose these different forms and elucidate them for the benefit of the worker in the field.

If we are to make the best use of our resources botanical research stations in different parts of the Empire, adequately equipped and under the charge of a capable trained botanist, are a prime necessity. We seem to have been singularly unfortunate, not to say stupid, in the management of some of our tropical stations and botanical establishments.

The island of Jamaica is one of the oldest of our tropical possessions. It is easy of access, has a remarkably rich and varied flora, a fine climate, and affords easy access to positions of widely differing altitude. It is interesting to imagine what Germany would have made of it as a station for botanical work if she had occupied it for a few years. The most recent account of the flora which pretends to completeness is by Hans Sloane, whose work antedates the Linnæan era. A flora as complete as available material will allow is now in course of preparation in this country, but the more recent material on which it is based is due to American effort. Comparatively recently a mycologist has been appointed, but there is no Government botanist to initiate botanical exploration or experimental work or to advise on matters of botanical interest. A botanical station ideal for experimental work in tropical botanical problems is a mere appendage of a Department of Agriculture, the Director of which is a chemist.

A botanical station for research to be effective must be under the supervision of a well-trained botanist with administrative capacity, who must have at his disposal a well-equipped laboratory and ground for experimental work. He must not be expected to make his station pay its way by selling produce or distributing seedlings and the like; a botanical station is not a market-garden. The Director will be ready to give help and advice on questions of a botanical nature arising locally, and he will be on the look-out for local problems which may afford items of botanical research to visiting students. Means must be adopted to attract the research student, aided if necessary by research scholarships from home. The station should have sufficient Imperial support to avoid the hampering of its utility by local prejudice or ignorance. The permanent staff should include a mycologist and a skilled gardener.

The botanical station does not preclude the separate existence of an agricultural station, but the scope of each must be clearly defined, and under normal conditions the two would be mutually helpful. Nor should the botanical station be responsible for work of forestry, though forestry may supply problems of interest and importance for its consideration.

Finally, I should like to suggest the holding of an Imperial Botanical Congress at which matters of general and special interest might be discussed. The visit of the British Association to Australia was, I think, helpful to the Australian botanists; it was certainly very helpful and of the greatest interest to those coming from home. Many of the addresses and papers were of considerable interest and value, but of greater value was the opportunity of meeting with one's fellow-workers in different fields, of conversation, discussion, and interchange of ideas, the better realisation of one's limited outlook and the stimulus of new associations. A meeting which brought together home botanists and botanical representatives from oversea portions of our Empire to discuss methods of better utilising our vast resources would be of great interest and supremely helpful. Let us transfer to peace purposes some of the magnificent enthusiasm which has flowed homewards for the defence of the Empire in war.

In this brief address I have tried, however imperfectly, to indicate some lines on which botanists may render useful service to the community. To a large extent it means the further development and extension of existing facilities added to an organised co-operation between botanists themselves and between botanists and the practical and commercial man; this will include an efficient, systematic cataloguing of work done and in progress. We do not propose to hand over all our best botanists to the applied branches and to

starve pure research, but our aim should be to find a useful career for an increasing number of well-trained botanists and to ensure that our country and Empire shall make the best use of the results of our research. Incidentally there will be an increased demand for the teaching botanist, for he will be responsible for laying the foundations.

Complaint has been made in the past that there were not enough openings for the trained botanist; but if the responsibilities and opportunities of the science are realised we may say, rather, 'Truly the harvest is plentiful, but the labourers are few.' Botany is the *alma mater* of the applied sciences, agriculture, horticulture, forestry, and others; but the *alma mater* who is to receive the due affection and respect of her offspring must realise and live up to her responsibilities.

The following Discussions then took place:—

1. *On Economic Mycology and the Necessity for Further Provision for Pathological Research.*

(a) *Introductory Statement by Professor M. C. POTTER, Sc.D.*

The real importance of this branch of botany to the nation and the vital necessity of a study of the causes contributing to the enormous food-wastage throughout the Empire need to be strongly emphasised.

A very large proportion of the world's commercial products are of vegetable origin, and all the plants providing such products are subject to the attacks of fungoid or bacterial parasites, the loss resulting from diseases of this nature being of enormous extent. It has been estimated that on the average about one-third of the various crops are destroyed. The loss to the German Empire on the cereal crop in one year was over twenty millions sterling, and Australia suffered to the extent of two and a-half millions through 'rust' of wheat alone. In England about one million tons of potatoes are lost by disease per annum, and in Northumberland and Durham alone about 250,000 tons of turnips and swedes, valued at 125,000*l.* The destruction of timber everywhere is most serious, and all Colonial crops such as sugar, rubber, coffee, &c., together with every kind of fruit, pay a heavy toll to the attacks of plant parasites.

It is rather remarkable that so little interest is shown in the study of economic mycology. Hitherto little encouragement has been given to the prosecution of research in phytopathology, and *problems of importance equal to any in any branch of science await solution in this section of botany.*

Our ordinary botanical courses should include a wider treatment of the fungi; and, while appreciating to the full the valuable results of cytological work, one may claim at the same time that it might reasonably be supplemented by study of the life-histories of the fungi from the point of view of their work in Nature. More students might thus be led to take up research upon economic lines who would be equipped with a broad scientific training founded upon sound principles of physiology, bio-chemistry, and bio-physics. There is great danger in a narrowly technical education, and it is to be feared that at present there is not a sufficient supply of suitably qualified men to undertake the investigation of problems in the etiology of disease.

The problems are extremely complicated, and large questions are involved which demand the application of fundamental principles of physiology and plant hygiene. The relation of host to parasite, the reaction of both to internal and external conditions open up a wide field of research. The therapeutics of the plant must be considered from the same point of view as animal therapeutics; and conditions of environment, predisposition, and questions affecting infection and immunity, must all form the subject of definite scientific investigation.

A close study of the life-history of a fungus often reveals some weak spot where it is specially vulnerable, and a knowledge of methods of natural infection and of conditions favouring the spread of the disease will often lead to an effective means of prevention.

The fundamental question of food-constituents and the associated theories of

manurial treatment, though much discussed, remain in a state not altogether satisfactory, and there is room for a more scientific basis of experiments.

Nitrogen may be cited as one of the most important of the food elements which are liable to abuse. Much has been written about the supply of combined nitrogen, but the harmful effect of excessive nitrogen has not received the attention it deserves. Numerous cases can be indicated in which plants are rendered specially susceptible to fungoid diseases through the improper use of this element.

The chemical effects of lime upon the soil have received great attention, but its action in neutralising soil-acidity is not sufficiently recognised. This is a most important factor in certain diseases, and it has been shown that alkalinity of the soil secured immunity of the host from attacks of *Plasmodiophora*, and that the soil calcium has not necessarily any relation to the disease. How far soil acidity or alkalinity are factors in other plant diseases is another point awaiting elucidation.

It is a matter for further research to determine how far such processes as transpiration, respiration, &c., may be modified by manurial treatment, and within what limits it may so alter the constituents of the cell-sap as to be usefully employed as a prophylactic treatment.

Great strides have been made in recent years towards a recognition of the needs of economic mycology, which have naturally shown how much more remains to be accomplished. The Destructive Insects and Pests Act has been put in operation by the Board of Agriculture as a necessary means of coping with the devastating spread of certain diseases in this country. The provision made for economic mycology under the Board of Technical Instruction for Ireland has been productive of great results. In some districts in England centres for pathological research are already established, but to cope with the manifold questions which present themselves many more investigators are wanted.

The establishment of the Phytopathological Laboratory at Kew, in touch with mycologists in all parts of the Empire, is another forward step which cannot fail to be of the utmost importance to our Colonies and at home. But more is required. Phytopathological Laboratories should be set up in various centres of Great Britain, these being linked up with the main central establishment at Kew. The variations of our soil and climate demand that stations should be distributed according to special local requirements; each district creates its own problems. Each station should be superintended by a thoroughly qualified botanist whose equipment should be such as to enable him to deal with the important pathological problems involving a knowledge of bio-chemistry and bio-physics.

The foundation of a central laboratory for the cultivation and distribution of pure cultures of fungi and bacteria would also be a development of great value to the nation. Dr. Kral's laboratory fulfilled a very important function in the distribution of organisms in pure culture of pathogenic and non-pathogenic bacteria and certain fungi; and now that this supply is no longer available we find ourselves in a position similar to that created by the lack of aniline dyes, optical glass, &c. The establishment was strongly advocated of a National Institution for pure cultures which would be comparable to the National Physical Laboratory, from which type specimens could always be procured and critical determinations assured, and which would be of sufficiently wide scope to serve the needs of the medical bacteriologist, the plant pathologist, the agriculturist, brewer, tanner, &c.

At the present time there is no catalogue of British fungi similar to the London catalogue of flowering plants, but through the assiduity of Mr. J. Ramsbottom a list of the Uredinales, Discomycetes, and Phycomycetes has now been published by the British Mycological Society.

Great value is attached to research in plant hygiene. A distinction must be drawn between mycology and plant pathology. The mere working out of life-histories is only the preliminary step, behind this lies a whole series of researches in chemical physiology and pathology which may throw light upon problems connected with both the animal and the plant. It may not be unreasonable to suppose that the plant may possess bodies analogous to the protective anti-bodies of the animal so well known in medical bacteriology.



Already animal pathology has gained much by botanical discoveries, and it behoves the botanist to seek in the advances of physiological chemistry, as affecting animal pathology, their significance in relation to plant diseases and immunity.

(b) *The Organisation of Phytopathology.* By W. B. BRIERLEY.

The need is evident for some body which will co-ordinate phytopathological science throughout the British Empire, and it is suggested that this may best be met by the establishment of an Imperial Bureau of Mycology. Attention may be drawn to the Imperial Bureau of Entomology, and the excellent work carried out by that body. The two bureaus would work in intimate correlation, and this would best be achieved were they autonomous sub-divisions of an Imperial Bureau of Phytopathology.

The principal functions that a bureau of mycology would perform are as follows :—

- I. It would publish a bulletin of mycological research, and an up-to-date and complete review of applied mycology. These, together with the corresponding entomological publications, would cover the entire field of phytopathology.
- II. It would encourage the collection of specimens and secure their authoritative identification with a reasonable degree of promptitude.
- III. Card indexes would be compiled relating to the various aspects of mycology, such as literature, diseases, parasites, census, &c.
- IV. The bureau would apportion grants, and appoint persons to investigate problems of special importance.
- V. It would function as a pure culture supply laboratory for the British Empire, and work in intimate contact with other similar institutions.
- VI. A complete collection of specimens illustrating plant pathology would be formed for reference, loan, and exchange.
- VII. The bureau would work in intimate and reciprocal relationship with the Universities and teaching institutions and be a centre of post-graduate studies.
- VIII. Together with the Entomological Bureau it would organise a biennial or triennial Imperial Congress of Phytopathology for the discussion of problems of international value or general importance throughout the British Empire.
- IX. It would co-ordinate mycology with certain areas of medical science.
- X. Finally it would be a centralising institution for the co-ordination of workers in all branches of the science, and as such would tend to further valuable collaboration and to eliminate useless duplication and waste of energy.

Such a bureau should be housed in a specially built institution containing large and well-equipped laboratories, with library, museum, and other accommodation for the performance of its functions; possess convenient and extensive experimental grounds, and be staffed adequately by experts in the several branches of the science. It should be of University rank and independent status, and absolutely free to express its own 'personality' in its development. It should be supported by grants from the British and Colonial Governments, and be managed by an honorary committee representative of British and Colonial mycology.

(c) *Training in Plant Pathology.*<sup>1</sup> By J. RAMSBOTTOM, M.A., F.L.S.

In this country and in our Colonies we have very few economic mycologists who rank in the first class. It cannot be denied that this is almost entirely due to a lack of proper training. A plant pathologist must know his general botany, but what seems usually to be forgotten is that he should also have a knowledge of soils and their properties, of manures and their effects, and of

<sup>1</sup> To be published in full in *Trans. British Mycological Soc.* for 1916.

the general principles and practices of agriculture and horticulture, if not also of forestry. It is suggested that such extended knowledge could be best obtained by having diploma courses of four or five years in economic mycology and in economic zoology. Further, a central pathological laboratory and experimental station should be founded in this country and the best economic botanists appointed to it. (Similar stations are also requisite in the tropics.) Here men who are to receive Government appointments could take their final year's study, having special facilities in the way of specimens, literature, apparatus, &c., and the most recent methods of attacking economic problems could be studied. Every branch of the subject should be treated at this institution from its practical side. From this station would go out the advice to farmers in the form of simple directions and explanations, while the full discussions of results could be published in the form of bulletins.

A definite policy should be adopted in the training and appointment of economic mycologists in place of the present haphazard system.

*(d) Some Problems connected with the Treatment of Fungous Diseases by Spraying.* By E. S. SALMON and Dr. J. VARGAS EYRE.

It may be taken as a sign of the recent agricultural progress that spraying against fungous diseases has been adopted permanently, as being both necessary and profitable, by the English farmer, more particularly by the fruit-grower.

A close acquaintance with the practical side of the subject, however, soon convinces one that a great deal remains to be done to make the work thoroughly efficient. The farmer, protected against fraudulent artificial manures by the operations of the Fertilisers and Feedingstuffs Act, is still unprotected by any legislation forbidding the sale of spurious fungicides, the use of which too often nullifies spraying operations involving a considerable expenditure in labour and materials. The remedy for this waste lies for the most part, undoubtedly, in the dissemination of scientific information, but valuable assistance would be given by legislation—such as that now in force in the United States—requiring that a certain standard is maintained.

It is clear that there is now among farmers in the best fruit-growing districts a strong tendency to make use of that technical advice which is brought to them as the result of research. The method of using the recently introduced lime-sulphur wash is one evidence of this. The sight of the farmer and his fruit foreman using the hydrometer in the process of diluting down the concentrated wash is now not uncommon in Kent.

While on the one hand we have the stimulating fact that in this branch of agriculture the farmer welcomes scientific guidance, we find on the other hand that research has proceeded—at any rate in this country—but a little way. The absence of scientific information on many points vital to efficient and economic spraying is due probably to the fact that, for the elucidation of the problems concerned, co-ordinated work is required of the mycologist, the botanist, and the chemist. If we consider the field of work, we find that its problems must be approached from three sides, concerning as they do (1) the fungus, (2) the host-plant, (3) the chemical substances of the fungicide.

The problem for the mycologist is to ascertain whether different fungi, showing approximately the same structure and mode of living on or in the tissues of the host-plant, show the same susceptibility to the same class of fungicide. For this purpose parasitic fungi may be divided into (i) those with a superficial mycelium which can be dealt with by the class of active (or direct) fungicides; (ii) those with a deep-seated mycelium, some of which can be dealt with by the class of potential (or preventive) fungicides; and a third division, of those fungi which expose the mycelium to attack by rupturing the cuticle of the leaf and which can be dealt with by the active fungicide, or the potential fungicide, according to the amount of vulnerable surface exposed.

The problem for the botanist is the investigation of the nature of the susceptibility to injury from fungicides shown by many cultivated varieties of plants. This susceptibility, which varies in degree and may be very marked, is evident when a fungicide containing either copper or sulphur is used. Thus, to mention instances, the two varieties of apple known as Cox's Orange Pippin and Duchess's Favourite are so susceptible to the effects of copper that when

Bordeaux mixture is used on them, at the lowest concentration at which it is efficacious as a fungicide, their leaves are affected to the extent that they drop off, while on other varieties of apples Bordeaux mixture at double the concentration can be used without causing injury. A remarkable case of injury caused by the vapour rising from solutions of soluble sulphides is observed with the variety of gooseberry called Yellow Rough. A lime-sulphur wash at a concentration which causes no injury when sprayed on the leaves of other varieties of gooseberry causes almost complete defoliation when sprayed on the leaves of Yellow Rough, or even when sprayed on adjoining bushes, or on the ground under the bush. Whether this susceptibility is correlated with any morphological characters, or is due to specific differences in protoplasmic reactions of the cells, are questions which should be answered by the botanist, and will give valuable help in solving the problem of the efficient spraying of the manifold varieties of cultivated plants.

The problem presented to the chemist is obviously that of finding materials which are able to cause death to the fungus without causing injury to the host-plant—a problem which is based upon knowledge of the behaviour towards plant tissue of different chemical substances. Much remains to be done in the direction of accumulating such information, and it is felt that some systematic work should be undertaken to ascertain what are the effects produced by different types of chemical substance, such as oxidising agents, colloidal substances, hormones, &c., towards living plant tissue.

With information of this kind it may be possible to classify chemical substances which have fungicidal properties according to the degree of intensity of their action in this respect and, also, with regard to their behaviour towards the host-plant.

The results which have been obtained from work of this kind in the case of copper fungicides are of sufficient importance to justify such work being largely extended. It is only by careful systematic study that the mode of action of fungicidal substances will become known. It will be necessary in this connection to study not only behaviour of a substance itself towards the fungus and towards the host-plant, but also the behaviour of substances which are closely related to it. For example, when investigating the mode of action of soluble sulphide spray fluids, it is necessary to carry out trials not only with different sulphides of the same element, but also with the corresponding sulphides of similar elements, because, by so doing, the particular action or activity may be observed to be toned down or otherwise modified so that the mode of action may become detectable.

Another aspect of the problem under discussion, and an important one, is the examination of the part played by certain attendant substances, not of themselves possessing recognisable fungicidal properties, but which cause the fungicidal property of another substance with which they are intimately mixed or in solution to become much more marked. It is thought probable that an instance of this kind is to be found in the case of paraffin, which when present in small quantity appears to increase the fungicidal intensity of a soluble sulphide spray fluid. Another case of a similar character is that where an increase in the concentration of soap renders solutions of liver-of-sulphur fungicidal. The importance of gaining information as to the behaviour of attendant substances towards the host-plant as well as towards the fungus will be obvious in view of the desirability for combining insecticides with fungicidal washes, the insecticide, from this point of view, being regarded as the attendant substance.

In the class of active sprays it is of paramount importance that the fungicide chosen should be brought into intimate contact with the fungus, and when this presents a surface which is difficult to wet owing to the presence of air films, some substance has to be added which will lower the surface tension of the fluid. It seems highly desirable that some reliable method should be devised for testing the wetting power of different spray fluids, and that a careful study of this problem be made.

---

2. *Discussion on the means to bring into Closer Contact those carrying out Scientific Breeding Experiments and those Commercially Interested in the Results of such Experiments.*

The discussion was opened by Miss E. R. SAUNDERS, who stated that it should be unnecessary at the present day to insist upon the extreme importance—in fact, the absolute necessity—for commercial success, of close contact between industry and science. The practical value of the results obtained by the scientific breeder could scarcely be over-estimated—in illustration one need only mention for example such experiments as those of Professor Biffen on the production of strains of wheat immune from rust—yet it could not be said that in general any real contact existed between the scientific breeder and the trades and industries to whose interest it was to apply the discoveries made by the breeder. This lack of co-operation had been brought out strongly at the meeting of the Association last year at Manchester in the case of the cotton trade. As a result steps had now, she understood, been taken by the manufacturers to remedy this state of affairs. In another case the trade had taken the initiative. A number of growers in a district in Hertfordshire had recently formed a society (Nursery and Market Garden Industries' Development Society) and started an experiment station for the investigation of the growers' problems by scientific methods. The inauguration of this scheme had been so successful that the station was now in receipt of a considerable grant from the Board of Agriculture and Fisheries. Instances such as those mentioned were, however, exceptional, and a more general and organised means of intercourse between the commercial man and the scientific breeder was much to be desired. Before considering what steps could be taken to facilitate such intercourse it would be well to consider the nature of the existing facilities to this end. These might conveniently be considered under the different heads of agriculture, horticulture, pure science, &c.

*Agriculture.*—Under the scheme recently drawn up by the Board of Agriculture and Fisheries it was proposed that for the purpose of educational work of university type in agriculture the counties of England and Wales should be grouped into twelve divisions or provinces, each associated with a central college engaged in teaching and investigating agricultural subjects, with skilled practical instructors in each county. The scheme provides for

1. Research to be carried on at National Research Institutes devoted to the study of different sections of agricultural science.
2. Consultative work by workers, stationed at collegiate centres serving groups of counties, who are concerned with the application of the results of research to practice, and who make a special study of the needs of particular localities.
3. Teaching by (a) Lecturers in Universities and colleges; (b) Teachers at farm schools; (c) Instructors employed in peripatetic work.

Eleven of these National Research Institutes had begun work by December 1915. Among those having relation to our present subject might be mentioned one at the University of Cambridge, of which Professor Biffen is director, for breeding new crops. It has not yet been found practicable to arrange for an Institute at which experiments in genetics on the larger farm animals could be carried out. Pending the establishment of such an institute a grant has been made by the Development Commissioners to Professor Punnett of Cambridge for the promotion of breeding experiments with small animals. At the Research Institute in Fruit-Growing at the University of Bristol some breeding experiments on Mendelian lines have formed a part of the work which has already been started.

With the object of furthering research, grants in aid are made from the Development Fund for Experiments and Research. The grants available for distribution under the scheme fall into four groups :—

1. Grants to Research Institutes.
2. Special Research Grants.

[In the Annual Report of the Distribution of Grants for Agricultural Education and Research for 1912-13, for example, mention is made of special grants for the carrying out of breeding work to University

College, Reading (Experiments on Wheat by Professor Percival), and to the South-Eastern Agricultural College, Wye (Experiments on Hops by Mr. E. S. Salmon).]

3. Grants for the provision of technical advice and for the investigation of local problems.
4. Grants for the provision of research scholarships.

Grants in aid of research institutes are payable only to certain institutions approved by the Development Commissioners. These institutions are required, as a condition of grant, to specialise in particular branches of agricultural science. Now the papers containing an account of the research work carried out at these institutes are published in various periodicals, but the majority appear in *The Journal of Agricultural Science* and *The Journal of the Board of Agriculture*. It must be borne in mind that both these Journals are concerned with all matters agricultural, and hence breeding results naturally constitute a very small proportion of the whole.

In addition to the Journal, leaflets are also issued by the Board from time to time containing information on practical agriculture, to which the same remark applies.

*Horticulture*.—A Horticultural Branch of the Board of Agriculture has lately been formed, which issues an annual report. This report deals for the most part only with plant diseases and pests.

The Royal Horticultural Society has its gardens and its own Journal. The Society has a large membership, and articles on Mendelian work appearing in the Journal would have a wide distribution, and should be of great use. But the Journal is intended to deal with all branches of the subject of horticulture, and, therefore, as in the case of the Journal of the Board of Agriculture, naturally only a small fraction of the contents relates to scientific breeding experiments. The Society's Shows might afford opportunity to some extent of giving ocular demonstration of results of breeding work, and this idea was, she believed, under consideration. Possibly arrangements might be made for exhibitions of this kind as a regular feature of the Royal Agricultural Society's Shows.

*Pure Science*.—Facilities under this head for bringing breeders and growers into contact might be regarded as almost negligible, since the original papers in which the scientific results are recorded, usually appearing in various scientific journals devoted to the subject of heredity, were as a rule of little use to the practical man not acquainted with the terminology, or with the earlier work in the subject.

After this brief statement of the position Miss Saunders brought forward the following proposals for discussion. These proposals were not to be regarded as resolutions in final form. They embodied various suggestions made by those with whom she had had an opportunity of discussing the matter, and were intended merely to serve as a basis of discussion :—

#### *Suggestions proposed for Discussion.*

1. That a memorial should be sent to the Board of Agriculture and Fisheries calling attention to the urgent need of bringing into closer contact the scientific breeder and those commercially interested in the results of breeding work, and urging upon the Board the advisability, as a preliminary step, of calling the trades concerned together, with the object of inducing them to organise Research Departments. These Research Departments would constitute the natural channels for the interchange of information between those concerned with the industrial application of the discoveries in genetics and the scientific workers.

The formation, by those engaged in the study of genetics, of a body (or centre)—a Genetics Association, with (if possible) some easily accessible headquarters—might do much to facilitate intercourse of this kind and to promulgate information on the subject of genetics generally. Such a body might make arrangements, *e.g.*, for

- (a) Periodic visits, by those interested, to different experimental stations and growing centres.

- (b) More frequent meetings at which breeders and growers would have an opportunity of meeting and of seeing exhibits or hearing discussions.

2. The publication in easily accessible form of

- (a) A record of the literature of genetics.  
 (b) Abstracts of the more important papers.

In regard to a record, a start might be made by the immediate preparation of a bibliography, to include the period from 1900 until the present time. Henceforward a number might be issued annually—a Year-Book of Genetics—containing the author's name and the title and place of publication of all papers on the subject, with (or without) an abstract or brief statement of the line of work. At intervals, e.g. every tenth year, a volume might be issued in which the contents of the ten previous Year-Books were all incorporated. In this work America might be willing to co-operate, and possibly other countries. In view of the practical advantages which the wider distribution of a knowledge of the results of experimental breeding would ensure the Board of Agriculture and Fisheries should be approached with a view to their undertaking the publication of an Annual Supplement to the *Journal of the Board of Agriculture*, containing an abstract or short account of the more important papers on the subject of genetics. Possibly co-operation might be arranged between the Board and the Royal Horticultural Society so that the work could be shared and the information be put in the hands of readers of both the Horticultural and the Agricultural Journals.

3. The formation of a Sub-Section Genetics in connection with Sections D, K, and M.

Professor BATESON supported the first proposal. As a preliminary step the Board of Agriculture might be asked to call together representatives of the trades concerned, with a view to the creation of a permanent organisation. This suggestion had been made by Mr. A. D. Hall, of the Development Commission, who had experience of similar cases. Such an organisation would facilitate the application of science at large. These things could not be forced down people's throats, and till the need for scientific aid were felt by the practical men nothing could be done. In the interests of the science it was certainly desirable that a Genetics Society should be created, if only to promote inter-communication between the workers in this country. The Society would also aid in the direction of Miss Saunders' first proposal. As to her second suggestion he was more doubtful. A bibliography of genetic work would be of little use to practical men. It would be a laborious undertaking; and, moreover, at the present time the bibliographies published by the *Zeitschr. f. Vererbungslehre* and by the *Zeitschr. f. Pflanzenzüchtung* provided all that was required by scientific workers.

Professor BOWER and Professor SEWARD supported the proposal to form a Sub-section Genetics in connection with Sections D, K, and M. Professor Bower considered that the proposal might even have been extended and a recommendation made to constitute Genetics a Section instead of a Sub-section.

Professor WEISS said that he doubted whether this proposal would have the desired effect of inducing the local commercial man to attend the meetings. He thought that the ordinary type of paper read at the British Association meeting would not attract these men, and that they would not be disposed to pay the membership subscription. He suggested instead that a Conference on Genetics might be held on a particular day during the meeting to which such individuals should be invited as delegates, at which suitable papers, discussions, or exhibits might be arranged.

Mr. A. M. SMITH said that so far as his experience went he thought farmers were quite ready to apply new methods when these were pointed out to them, and that the outlook was perhaps more hopeful than some speakers had indicated.

The PRESIDENT, in closing the discussion, suggested the formation of a Committee to consider further the proposals which they had had before them, and take such steps as it might decide upon to carry them into effect.

[A Joint Committee of Sections D, K, and M has been approved.]

*Joint Meeting with Section C.*

The following Report and Paper were received :—

1. *Report of the Committee for Excavating Critical Sections in the Old Red Sandstone Rocks at Rhynie, Aberdeenshire.*—See Reports, p. 206.

---

2. *On Rhynia Gwynne-Vaughani.*

By Dr. R. KIDSTON, *F.R.S.*, and Professor W. H. LANG, *F.R.S.*

At Rhynie, in Aberdeenshire, well-preserved silicified plant-remains occur in a chert bed, not younger than the Middle Old Red Sandstone. There are two vascular plants—*Rhynia Gwynne-Vaughani* and *Asteroxylon Mackiei*, discovered by Dr. Mackie. The present paper deals only with *Rhynia*, an illustrated account of which is in course of publication by the Royal Society of Edinburgh. *Asteroxylon* is still under investigation.

The plants of *Rhynia Gwynne-Vaughani* grew closely crowded together, and their remains formed a peat. The plant was rootless and leafless, consisting entirely of a system of cylindrical stems. The rhizome was fixed in the peat by rhizoids and tapering aerial stems grew up from it. The plant probably attained a height of 8 inches or more, and the stems range in diameter from 6 mm. to under 1 mm. The stems bore small hemispherical projections. In place of some of these projections lateral branches developed. Dichotomous branching also occurred sparingly.

The aerial stems had a thick-walled epidermis with stomata; a cortex, distinguished into a narrow zone of outer cortex and a broad inner cortex; and a simple central cylinder, consisting of a strand of tracheides surrounded by phloem.

Large cylindrical sporangia, containing numerous spores, were found in the peat. They were evidently borne terminally on some of the leafless aerial stems.

*Rhynia*, and some of the specimens of *Psilophyton princeps* figured by Dawson, cannot be placed in any of the main classes of the Vascular Cryptogams (Filicales, Lycopodiales, Equisetales, Sphenophyllales, Psilotales) at present defined. A new class, for which the name Psilophytales is proposed, is therefore founded for their reception. This is characterised by the sporangia being borne at the ends of branches without any relation to leaves or leaf-like organs.

---

THURSDAY, SEPTEMBER 7.

The following business was transacted :—

1. *On Leaf Architecture.*<sup>1</sup> By Professor F. O. BOWER, *F.R.S.*

2. *Discussion on the Utilisation and Improvement of Waste Lands.*  
Opened by Professor F. W. OLIVER, *F.R.S.*

The present collection of short papers dealing with the general subject of Waste Lands were delivered before the Botanical Section (K) of the British Association at the request of the President of the Section. The question of the utilisation and improvement of Waste Lands was one of a large number which had come under the notice of the Sectional Committee. Several members of the Section having had practical experience—botanical, geological, or economic—of ground of this kind, it was decided that a sufficient number of communications should be arranged with a view to forming the basis of a discussion

<sup>1</sup> Published in *Trans. R. S. Edin.*, 1916, vol. iii., part iii., p. 21.

on a topic of current interest and considerable national importance. The abstracts which follow represent the subject-matter of the papers communicated on the occasion referred to.

Waste lands may be defined as ground not hitherto exploited, or, at any rate, utilised only to a slight extent. They are capable of great improvement in respect of fertility and of being put to unaccustomed uses.

As the recent tendency for land has been to fall from a higher to a lower economic plane, waste lands, which from this point of view lie at the bottom, have received relatively little consideration.

With the changed conditions brought by the war, it has become necessary that food and other raw products should be raised at home in increasing quantities. Thus in some measure our imports will be restricted, money will be kept in the country, and additional rural occupations found for our people.

Lands remain waste, *i.e.*, unproductive, in an old country like Great Britain from some obstinate physical or chemical defect, or from lack of intelligence or imagination in the matter of their exploitation. The principal causes may be grouped under the following heads:—

- (1) *Poverty* in some ingredient directly or indirectly essential to plant growth, *e.g.*, nitrogen, potassium, phosphorus, or lime.
- (2) *Mobility*: liability to erosion by sea, rivers, rain, or wind. Animals such as rabbits have a similar effect on light sandy soils.
- (3) *Toxicity*, from acidity of soil or presence of salt.
- (4) *Dryness*, which can be corrected by irrigation.
- (5) *Remoteness*.
- (6) *Ignorance*, inertia, deliberate intention, and general 'cussedness.'

Roughly speaking, there are two ways of exploiting such terrains.

- (1) *Utilisation*—the fostering of the spontaneous vegetation which may have an economic value by the introduction of method and technique.

Thus a salt-marsh might be utilised for the cultivation of an economically valuable halophyte.

- (2) *Conversion or reclamation*—the terrain may be transformed by stabilising, draining, irrigating, or altering in other ways involving great expense and labour, so that the land may be used for raising crops that would not grow upon it were it not so treated.

According to this system, a salt-marsh would be banked and drained, and transformed into arable ground.

It is often forgotten that waste land is rich in many things, that it is a soil on which the sun shines. Ideas and unremitting toil in carrying them out are here, as elsewhere, the only road to success. The exploitation of waste lands has the especial attraction of being pioneer work; for, generally speaking, exploitation will involve doing something with them which has never been done before.

The communications which follow deal with several types of such land and from a variety of points of view.

### I. *The Planting of Pit Mounds.* By P. E. MARTINEAU.

Waste lands are of two kinds, natural and artificial, and this paper deals solely with the latter. It relates to experimental work of the Midland Reafforesting Association in the districts of South Staffordshire and North Worcestershire, known as the Black Country.

The Association came into existence in 1903, and completed its first two plantations at the end of 1904, some five acres. The total area now under trees is about eighty acres.

The district lies high, from 500 to 700 feet above the sea, and is on the main watershed of England. Part of it therefore slopes rapidly S.W. towards the Severn and the greater part very gradually northwards towards the Trent. The rainfall is approximately 30 inches per annum. The wind is strong and the banks are much exposed to it.

The banks are of three main types, furnace-slag, clunch or shale, and burnt out coal-waste or carbonaceous shale. Of these, the first may be neglected as



the stuff has its price and is all being removed by degrees for railway ballast. The third kind generally takes fire and the fires may burn for twenty years. When burnt out the resulting soil is a red and friable ash.

The general result of the Association's experiments is that the black alder will grow anywhere, on stiff clunch or on loose ash; the white alder, so successful on dry mounds in France and Belgium, has not done quite as well as the black, but is making good fertilising nodules and will ultimately do well. On the loose ash, birch does very well, except where fumes are unusually dense. Where a richer growth of grass indicates a better soil, ash and sycamore have been planted, and are now beginning to do well. Wych-elm, the commonest tree of the district, is also doing very well.

The plantations formed in 1905 to 1908 are now from 18 to 24 feet in height. Black poplars, which surround some of the plantations, have reached a height of nearly 30 feet.

There are fourteen thousand acres (estimated) of pit-bank in the Black Country, and the other coal-fields of Britain present many times that area. The Association has only a few acres successfully planted, but sufficient to show that, with proper precautions, the whole of this waste area could be utilised for the growing of timber. In some districts larch, Scots pine or spruce might be grown, and the Association has begun to experiment with Sitka spruce, but the Black Country atmosphere is not suitable for conifers, and some other district would make more useful experiments.

The cultivation is of the simplest. Pits have been made a spade deep, and the rough turf or weeds put in the bottom of them. The labour has been entirely of the casual type, and has proved quite satisfactory, as was indicated by the Association's evidence before the Royal Commission on Coast Erosion. The cost of planting must vary with local conditions, but may be generally stated at about 6*l.* per acre, with a charge of about 1*s.* per linear yard for the necessary fencing (1,742 trees per acre, *i.e.*, five feet apart).

The commercial side of the experiment has not yet matured, but birch and alder are both marketable in Birmingham and the Black Country at a good price, being much in demand for handles of small tools, of electric switches, and of numerous utensils. It is reckoned that in five or six years the Association will be able to put on the market some tons of timber at a price much higher than that which growers of coniferous wood expect after forty years of waiting.

A medal was awarded at the Royal Agricultural Show, Shrewsbury, 1914, to the Association for an exhibit showing the uses to which small alder and birch timber are put, and the progress made in furnishing a new source of supply.

Closer planting would be a great improvement; the best distance has proved to be four feet apart, or 2,722 trees per acre at a proportionately higher cost.

## II. Maritime Waste Lands. By Professor F. W. OLIVER.

These include, in particular, sand-dunes, shingle-beaches, and salt-marshes. It is proposed to draw attention here to certain ways in which the first and last named are capable of exploitation. The suggestions made are not intended to be exhaustive, but merely as illustrations that have come under the notice of the writer of what may be done.

*Sand-dunes.*—These have a primary significance in coastal defence, and the utilisation of dunes should be subject to that condition.

Dunes are commonly fixed by marram-grass (*Psamma arenaria*), and for the fixing to be efficient the marram should be planted.

In this country no very urgent necessity has ever been felt to treat sand-dunes seriously because they are relatively small and their wandering has not raised acute problems as in Gascony and on the Baltic. In the Netherlands, of course, the existence of the country largely depends on the proper upkeep of the dune barrier. It would be easy to show the folly of our slovenly neglect and carelessness were not the space available needed for the consideration of other aspects.

Australia, New Zealand, and South Africa have found it necessary to put

their sand-dunes to rest, and the most valuable of recent contributions on the strategy and technique of dune planting come to us from overseas.<sup>1</sup>

We have, however, a fine object-lesson in the pine-woods (Austrian, Corsican, and Scots) which have been raised on the dunes of Lord Leicester's estate at Holkham in Norfolk. As originally planted these woods were not intended for exploitation, but by natural regeneration they are attaining to the condition of exploitable forests.

If it is a matter of urgency that more timber be raised in this country, and nobody is likely to deny it, then our dune systems should be considered from that point of view. And this is the more urgent as in not a few cases extensive dune areas are no longer being fed by sand from the original source but are being gradually blown away, and in another fifty to a hundred years will have ceased to exist. A case in point is the Brancester-Burnham dune system on the north coast of Norfolk, where the evidence of shrinkage from this cause is incontrovertible. If the dunes are not planted within a reasonable period there will be no ground left to plant.

An alternative to conversion to forest is the utilisation of dune areas for the improved cultivation of marram-grass. Paper experts have reported very favourably on the prospects of marram as a raw material for the manufacture of paper,<sup>2</sup> though I have not heard that it has been commercially exploited in this sense hitherto. The fibre obtained belongs to the same class as Esparto-grass, and can be dealt with in the mills where Esparto is treated. Before the war we imported some 200,000 tons of esparto-grass from Southern Spain and the North African coast at a cost to the paper manufacturer of 3*l.* 10*s.* the ton.

During the present summer I cut in Norfolk trial areas of rough uncultivated marram dunes and found the yield to be about 2½ tons of dry grass per acre. If this result be corroborated in other cases, it is evident, having regard to the prices mentioned, that the matter deserves serious attention.

We have still to find out how often an area can be cut, the most economical distribution of shelter belts so that the sand shall not be blown away from the stubble, the effects of manures, and the possibility of applying reaping machinery on ground of this kind.

For a maximum output it will be necessary to plant the dunes with marram, an operation well understood and costing where the most approved methods are followed, according to Gerhardt's estimate 4*l.* per acre, and according to the Australian exploitation at Port Fairy, Victoria, 4*l.* 5*s.*—all charges included. The subsequent details of cultivation for regular cropping have, of course, to be ascertained by trial.

I should estimate that the cut of closely grown, planted marram-grass should approximate to four tons dry grass per acre. In selecting areas for marram production it would be well to avoid those where there is a tendency to stagnate; moreover, extensive, homogeneous areas seem preferable to the narrow coastal fringe. In this case, then, we should look to Cornwall, North Wales, the coast of Scotland, and the well-known Southport area as the headquarters of this kind of exploitation.

There are other methods of dune conversion that should also be considered by any supreme body that may take over the control of our waste lands; but what has been said above may suffice for the immediate object of drawing attention to the potentialities of these neglected areas.

*Salt-marshes.*—These being tidal require banking before they can be exploited for cultivation. The fertility of banked marshes is well known, and requires no emphasising here.

Extensive areas are ripe for banking without prejudice to navigation, and the only remark to be made is that the inevitable period of transition between the disbanding of our armies and their reabsorption into civil life should afford the opportunity for putting through works of this kind, works analogous in nature to the entrenchments which soldiers are accustomed to undertake.

<sup>1</sup> L. Cockayne, *Report on the Sand-dunes of New Zealand*, N.Z. Department of Lands, 1909. J. H. Maiden, *The Sand-drift Problem in New South Wales*, in *The Forest Flora of N.S.W.*, pt. lvii. 1915.

<sup>2</sup> *Kew Bulletin of Misc. Information*, 1912, p. 396; 1913, p. 363.

What is required without delay is the means for making the necessary decisions as to the areas to be reclaimed and the preliminary organisation in preparation for the work. Time probably is still available for these preliminaries, as labour from the source indicated is not likely to be available for a considerable period.

Should we ever be in a position to follow a policy in reclamation thought out some years in advance, it would be possible to expedite the process of silting up of marshes by appropriate planting. The study of the sequence of natural plant successions has shown that measures of this kind are perfectly feasible.

In addition to avoiding haphazard and piecemeal reclamation, another useful duty that would fall to the lot of a department in supreme control should be to determine how far a proposed reclamation is consistent with the maintenance of proper navigation to ports in the vicinity. Whoever studies the present state and previous history of the dead ports of the north coast of Norfolk can hardly fail to agree that their decayed state is mainly attributable to imprudent methods of land-reclaiming that have prevailed in past times.

Before leaving the subject of the salt-marsh there is the question of direct utilisation in contradistinction to conversion or reclamation. The species of plants that flourish on tidal marshes are, as is well known, limited in number; not more than 1½ per cent. of all British plants are halophytes, and this of course circumscribes the possibilities of utilisation.

There is, however, on the South Coast a plant which has latterly appeared in enormous quantities on the mud flats of Southampton Water and Poole Harbour, and which is certain to penetrate into other areas. Public attention was first called to the spread of *Spartina Townsendii*, some nine years ago, by Lord Montagu of Beaulieu, and a good deal of precise information as to this plant has been made available by Dr. O. Stapf. *Spartina* now occupies thousands of acres in the areas named and is still rapidly spreading—particularly in Poole Harbour, where it was first detected in 1899. Nothing, however, seems to have been done to put this gift of Providence to any definite use, though cattle are reported to come down to graze on it with avidity where the ground has become sufficiently consolidated. Curious to know whether the paper-maker might not be able to find some use for *Spartina*, a sufficient sample for technical treatment was obtained through the good offices of Mr. B. K. Hunter and a 'mixed' squad from a school within reach of Poole Harbour. The expert report based on an investigation of this sample is altogether favourable to the idea that good paper can be derived from *Spartina Townsendii*, and, should the quantitative results based on the treatment of further material prove equally satisfactory, it is permissible to hope that a thriving industry may spring from the exploitation of this plant. The present situation, which must tend to restrict the supply of imported raw materials for the paper-mills, is, of course, favourable to the recognition of the good qualities of a home-grown plant, and it is to be hoped that by intelligent and energetic exploitation *Spartina* may become one of the staples of our paper-manufacturers.

The above examples of the possible utilisation of waste lands by the sea could easily be multiplied. They indicate the existence of a considerable field well deserving a closer investigation than it has yet received. The writer believes the time is ripe for the preparation of a much fuller survey and report of this type of ground than has hitherto been considered necessary. And what is true of maritime waste lands applies with equal force to other types. It is much to be hoped that a powerful central authority, such as the Board of Agriculture and Fisheries, may be able to direct attention to these matters, to institute the necessary inquiries, and do what can be done in the way of initiating exploitation in promising cases. In our view, the whole question might be referred to a permanent or semi-permanent department competent to deal with all sorts of waste grounds. This plan seems preferable to separate or 'water-tight' action, as the problems of utilisation and conversion of the different types of ground have much in common, and the experience gained in one case should be directly applicable to another. Such an authority, once in operation for the British Isles, should soon find itself working in close touch with similar bodies representing the larger and lesser units of the Empire. The scope of the field thus opened up would, of course, be practically unlimited.

### III. *Utilisation of Northern Mountain and Heath Land.*

By Dr. WILLIAM G. SMITH.

This is land which has never been ploughed, except a small proportion of old cultivation now reverted to a more or less wild condition. The herbage may be grouped into vegetation on peat, heather land of the dark-toned hills, and several types of green hill, consisting of various grasses, sedges, rushes, and bracken. The area of this vegetation is considerable. Recent returns of the Board of Agriculture for Scotland show the following subdivisions of the land, nineteen million acres, exclusive of water:—

- Crops and cultivated grasses, about 25 per cent.
- Woods and plantations, about 4·5 per cent.
- Mountain and heath land used for grazing, about 48 per cent.
- Remaining area, about 22·5 per cent.

The last item includes urban and industrial land, and hill land not specified as used for grazing; the proportion is high in the Highland counties, where it is mainly deer-forests and grouse-moors. Hence about 60 per cent., say 18,000 square miles, of Scotland is uncultivated land of the kind under consideration. For the Northern Counties of England the proportion is about 25 per cent., say 3,000 square miles. This hilly land is not waste, because almost every acre brings in some income and is utilised in some way. The income, however, is small while the area is large, so that there is a great opportunity for improvement, since a slight increase in food-production—directly or indirectly—amounts to a large aggregate.

The vegetation is considerably varied, in accordance with a wide range of topographic, climatic, and edaphic conditions. Hence no uniform system of utilisation is applicable. The problem is further complicated by existing economic conditions. The pasturage of sheep and cattle is a direct means of maintenance for a local population and of food-production for the nation. Forestry brings with it local maintenance and the production of wealth in the form of timber. On the other hand, grouse-moors and deer-forests are not directly productive, and yet they constitute a means of utilisation of considerable importance. As regards the merits of the types of land exploitation indicated, there is room for wide variations of opinion, and the different aspects have not been simplified by controversy often conducted with insufficient knowledge. The subject is therefore a thorny one for generalisation. On the present occasion what is required is the simplest possible statement, mainly rudiments and commonplace to anyone who has studied the subject in detail.

Improvement and increased production from hilly areas can only follow on a closer examination of existing modes of utilisation. Indeed, the stages leading up to present utilisation are themselves improvements in some direction or another, and are suggestive for the future. Such improvements fall into two groups—simple and complex. Simple improvements under present conditions include amelioration of the herbage, such as might be effected by perfecting the system of grazing, or by the application of manures or other methods. Again, the yield of commercial timber from woodlands might be considerably improved. The simpler methods involve relatively little expenditure and will give a direct return in a short time. Complex improvements include increased tillage of the valleys, accompanied by increased production of crops and stock, and better facilities for transport and distribution of produce available for sale. In another direction, forests might be established on land of low value. These and allied systems of improvement involve economic readjustment, and seem to demand some degree of co-operative or State initiation and control.

*Deer-forests.*—Deer for the greater part of the year frequent the higher ground. The herbage includes the dwarf turf of the more exposed summits and slopes, the mixed grass and sedge herbage of more sheltered slopes and valleys, and the extensive peat-vegetation of high peaty plateaux. This summer grazing lies most above 2,000 feet altitude: that is above the tree-limit, and unsuitable for sheep and shepherding except in the few summer months. In winter the deer migrate to the lower valleys, and the provision of wintering grounds within the deer-fence has led to displacement of tillage, sheep, and

cattle with their dependent population. Deer also damage the valley woods and discourage extension of forestry there. The reason for the extension of deer-forests is a demand for them, and the consequent increase of the landowner's income. The value of each stag to the shooting tenant is from 25*l.* to 30*l.*; the rent resulting to the landowner is from 1*s.* to 3*s.* per acre. For the high summering ground the summer grazing of sheep brings in from one penny to threepence per acre. The following example is instructive:<sup>3</sup>—The average aggregate rental of a certain block of deer-forest is 5,300*l.*; if this were only utilised as summer pasturage for sheep the rental is estimated at 500*l.*; with the addition of rent for grouse and other game it might reach 2,000*l.*; the balance in favour of deer is obvious.

*Grouse-moors.*—These centre round the heather (*Calluna*) and other *Ericaceæ*, &c., the shoots, seeds, and berries of which form the chief food-supply for grouse and allied game. The *Calluna* zone of the Highlands lies below the summit region, and this zone is mostly suitable for sheep-pasturage and forestry, so that grouse-moors are competitive with sheep and timber. There is a large demand for shooting-moors in normal times, and the landowner's income varies from one or two shillings up to even five shillings per acre. This may be doubled if sheep are grazed over the same ground, and if the shooting and grazing are under one control this arrangement works well. With dual control of gamekeeper *versus* shepherd, the general result is that sheep are discouraged on the more highly rented grouse-moors. Cases could be quoted where the sheep-stock has been deliberately reduced on the plea of disturbance of game. In practice, and in spite of the recommendations of reports such as those of the Grouse Disease Committee, the average keeper tends to maintain his heather in a condition not the best for sheep.

*Pasturage.*—A century or more ago, the grazing-stock of the hill districts included more cattle than is now the case. The summer grazing of cattle in the more inaccessible localities was effected by the 'shieling' system, corresponding to the 'chalet' or 'Sennhütte' system on the Alps, or the 'Sæter' of Norway. Gradually sheep-pasturage has increased, and now there are extensive areas entirely under sheep, or with a few cattle grazed on the lower slopes. At first the sheep belonged to many small holders who had the right of common pasturage over large areas of hill-grazings. But from various causes the small holdings have gradually become grouped under one occupier, so that now the greater part of the hill-grazing consists of large holdings of several thousand acres each. In Scotland the holdings exceeding 300 acres (the largest given in the Returns) numbered in 1914 only 2,600, of which some are lowland arable farms, and of the hill-farms a single owner or tenant often holds more than one. This transition from mixed stock to sheep alone, and from small holdings to large, is probably a natural process of concentration and cheaper working. Along the trail of the movement there has been rural depopulation, accompanied by a shrinkage of the ploughland, and the lack of home-raised young cattle has forced the lowland farmer to find in Ireland the cattle to consume his crops.

Since sheep-grazing is the greatest and most direct source of food-production on the northern hills, it is natural to suggest increase of the flocks. This, however, is not quite simple. The stock maintained depends chiefly on the available food-supplies during critical periods, during snow or when herbage is adversely affected by cold or drought, *e.g.* in the spring months. It is a common practice to move part of the flock from the higher sheep-farms to lowland farms in autumn to be wintered. The sheep remaining at home utilise the lower ground with grass and heather. During snow they are fed with hay, some of which is grown in fields on the farm itself, but frequently the fodder has to be brought from the lowlands. Increase of locally produced hay requires further inclosure and tillage of suitable valley alluvial deposits. In the case of existing enclosed grasslands a considerable increase of hay and grazing is possible by the use of artificial manures.

Pasturage during the more favourable parts of the year extends over the whole grazing area: that is, up to 3,000 feet or more on the better grazing hills of the Highlands. To facilitate shepherding each flock is divided into units ('hirsels') or still smaller units ('hefts'), and it is important that the grazing

<sup>3</sup> Lovat and Stirling, *Afforestation in Scotland*, p. 15; Edinburgh, 1911.

allotted to each unit should include several types of herbage, since these vary in nutritive value and at different times of the year. The following plants form types of vegetation, pure or in mixture: Heather (*Calluna*) is one of the more important plants, and furnishes grazing for Black-face and other hill-breeds of sheep all through the year. Cotton-sedge (*Eriophorum*) occurs on peat, and is valuable during the flowering season in spring. Purple heath-grass (*Molinia*) has some grazing value in early summer, and this is increased where the plant association includes heather. *Nardus stricta* is another widely distributed type, but it is less useful. Grassland on stream alluvia and on slopes flushed by spring-water is an essential item of the herbage of every flock-unit.<sup>4</sup> The proportion of each type of vegetation varies with the district. Thus, *Calluna* is relatively more abundant in the eastern districts than in the western, where there is a preponderance of greener herbage and peat vegetation. Because of the local variation of the herbage there is no fixed number for a flock-unit, nor can any definite area be allotted; some of the better hill-grazings carry one sheep to the acre, others are nearer four acres to a sheep. There is considerable opportunity for improvement in the production of the hill-grazings. Amongst methods in actual operation the following may be indicated:—

*Drainage.*—Surplus water is generally removed by open surface drains. In the case of peat this dries the surface and encourages heather. It also localises the peaty water which causes deterioration, e.g., of good grassland on slopes, into *Nardus*. On fine-soiled alluvia, drainage encourages the finer grasses to replace *Juncus* and *Carex* spp., which are less useful.

*Irrigation*, or artificial flushing.—In some districts (e.g., S.E. Scotland), where *Calluna* is in excess and grassland deficient, the latter can be encouraged by leading spring water, emerging on the valley slopes, by means of open ditches so arranged that the water overflows on to heather, which is thereby rapidly displaced by grassland. This is the result of constant or periodic watering by more or less hard water, accompanied by surface aeration and by top-dressing with fine mineral matter.

*Periodic burning.*—The types with dominance of *Calluna*, *Eriophorum*, *Molinia*, and *Nardus* are treated by periodic burning. Heather (*Calluna*) at some age (15 to 25 years) begins to lose vigour; it assumes a grey colour due to scarcity of fresh green shoots, hence low feeding value; the flowering is also reduced. When this is fired, generally in the spring months up to middle of April, the old plants are destroyed and the ground is left bare. *Calluna* returns mainly by seedlings, less frequently from renewal-shoots arising from dormant or adventitious buds at the base of old stems. The time required for renewal of a close covering varies from five years upwards, and depends partly on the age of *Calluna* when burned, partly on the soil. The slowest return is after *Calluna* burned old on 'hard' soils with a scanty surface layer of humus. The quickest return is after *Calluna* burned young on surface-drained peat or on soils with several inches of humus. During the period after burning the area may be occupied by a transitional vegetation, e.g., *Erica cinerea* on dry soils, *Erica tetralix* on moist soils, *Vaccinium Myrtilus*, *Nardus*, *Molinia*, *Juncus squarrosus*, &c.; these may become more or less permanent and displace *Calluna*. The maintenance of the maximum food-supply requires that the heathery herbage be burned in patches or blocks, the total area of which varies according to the rotation. With pure heather the annual proportion for any given area should be one-fifteenth for a fifteen-year burning rotation; some moors are burned over every ten or twelve years. Where the heather is mixed with cotton-sedge, &c., as on peat, a seven-year rotation is preferable. If the herbage is mainly *Molinia* or *Nardus*, better grazing is supplied by burning every two to four years. The number of years applies only where abundant seedlings or renewal-shoots come within two years after burning. These proportions to be burned annually are seldom attained in practice, although the recommendations of the Grouse Disease Committee<sup>5</sup> have been beneficial. With increased burning

<sup>4</sup> Cf. 'Types of Upland Grazings,' D. Macpherson and W. G. Smith, British Association, Sect. M., Manchester, 1915.

<sup>5</sup> 'The Grouse in Health and Disease.' *Report of the Committee of Inquiry*, 1911. Popular edition, London, 1912.

the sheep-stock can be increased in numbers and quality, and the grouse-bag is increased, hence a higher rental.

Some wider schemes for improvement can only be indicated. Restriction of areas of deer-forests and grouse-moors to the more inaccessible parts would precede an opening-up of the lower valleys for increased wintering of sheep and for tillage. Increased grazing of cattle along with sheep would lead to better utilisation of the herbage, especially that of the *Nardus*, *Molinia*, and bracken (*Pteris*) zones. Increased tillage with oats, turnips, and grass would provide wintering for the cattle. An important scheme by Lord Lovat and Captain Stirling<sup>6</sup> outlines the afforestation of considerable areas of high valley slopes in such a way that existing sheep-farms and deer-forests would not be interfered with. The scheme is based on experience of areas bordering the Caledonian Canal, and is treated in considerable detail; hence it is an important guide in adding forestry to the local resources of the land.

#### IV. Waste Moorlands. By Professor W. B. BOTTOMLEY.

On the slopes of the Pennines, stretching from Derbyshire northwards into Scotland, there are hundreds of acres of waste moorlands. The top of these moors is usually covered with peat, whilst the slopes form very poor grazing-land, carrying only a few sheep to the acre. That this land can be rendered productive is shown by the cultivated fields around the sparsely scattered farm-houses along the moor-side.

Drainage, fencing, cultivation, &c., might be too expensive to attempt reclamation of these poor lands on a large scale, but recent experiments have proved that by the application of suitable manures the grazing value can be greatly increased. Farmyard manure, lime, and phosphates are the chief essentials. Unfortunately, farmyard manure in necessary quantities is difficult to obtain in these localities. Nature has provided, however, in the peat of these districts a substance which by simple and inexpensive treatment can be converted into a valuable manure. This raw mountain-peat, although wholly organic and often containing two to three per cent. organic nitrogen, is useless as a manure owing to its acid nature. When treated with bacteria, incubated and sterilised, the acidity is destroyed, a large amount of the organic matter is rendered soluble and available for plant-food, and certain growth-promoting substances are formed. Experiments conducted during the past summer at the Imperial College of Science, London, on the growth of *Lemna* plants in water-culture solutions, have demonstrated that the growth-promoting substances, known as auximones, obtained from bacterised peat have a remarkable effect on plant-growth.

Two series of water-cultures, ten dishes in each series, with twenty *Lemna* plants in each dish, were started on June 9, 1916, series A with complete Detmer-culture solution only; series B with Detmer solution plus the soluble extract of one gramme of bacterised peat in 1,000 c.c. of water. After six weeks' growth the following results were obtained:—

	Number of Plants.	
	At commence- ment.	After six weeks.
Detmer . . . . .	20	326
Detmer + peat-extract . . . . .	20	6,722

#### Dry Weight of 100 Plants in Milligrammes.

	At commence- ment.	After six weeks.
Detmer . . . . .	12 mgs.	5.4 mgs.
Detmer + peat-extract . . . . .	12 mgs.	16.5 mgs.

The effect of the peat-extract was evident not only in the more rapid multiplication of the peat-plants, but also in the size and weight of the individual

<sup>6</sup> *Afforestation in Scotland*, Edinburgh, 1911.

plants. The practical value of this treated peat in increasing the productivity of moorlands has recently been demonstrated on a small scale. On the moors above Entwistle, near Bolton, Lancs., there is an extensive bed of peat. Some of this peat was bacterially treated and used on the adjoining moorland. One portion dressed at the rate of one ton to the acre produced a crop of hay. On another portion which had been ploughed and limed the previous year the bacterised peat doubled the yield of oats and mangolds.

The method of treating the peat is simple and inexpensive. The necessary plant consists of shedding, bins in which to bacterise the peat, a disintegrator, and a boiler and engine. For an outlay of 250*l.* a plant could be erected capable of producing twenty to thirty tons of bacterised peat per week. As there are unlimited amounts of mountain-peat available, the manufacture of bacterised peat ought to be commenced at once in a number of peat districts. By converting a waste material into a valuable manure and applying it to the neighbouring poor land the home production of food would be materially increased.

### V. Reclamation of Peat-lands in Carnarvonshire.

By Professor J. LLOYD WILLIAMS and G. W. ROBINSON.

Scattered throughout the county of Carnarvon there are thousands of acres of peaty soils. The character of the peat varies greatly, but there can be no doubt that large areas could be reclaimed with profit and made to contribute to the wealth of the nation. The types surveyed can be illustrated from examples occurring in the South Carnarvonshire peninsula, extending in a south-west direction from the foot-hills at the base of the Snowdon mass. The reclaimable areas quoted are strictly confined to such as have already shown by actual experiment that they are capable of yielding good results.

I. *The Quarry Districts along the Foot-hills of the Snowdon Range.*—Here, at altitudes of 700 to 900 feet, are numerous large tracts of thin peat over a hard, stony, boulder clay. The natural vegetation is chiefly *Nardus*, *Molinia*, *Festuca ovina*, short heather, and ling and tormentil, with *Sphagnum*, cotton grass, and sedges in the wetter parts. In spite of the unpromising appearance of these tracts, frequent enclosures are walled off—small holdings reclaimed during leisure hours. The massive stone walls indicate the nature of the reclamation practised, for they consist of the boulders cleared from the waste. No special methods are employed, but good crops of oats and potatoes are grown, and, though in most cases only 'home' grass seeds are sown, these yield good pasture and hay; in two cases excellent crops of timothy were observed—one of these fields had been laid down eight years previously. The contrast between these oases of lush green and the brown heathery wastes surrounding them is most striking.

Along strips of hill-slopes, aggregating a length of about thirty miles, many hundreds of these reclaimed holdings have been made by the quarrymen during the last eighty years. The soil in many cases is a strong loam containing a high proportion of organic matter. The following figures may be instructive: they are the analysis, A of the soil of a small holding near Llanllyfni (Glan y Gors), and B of the soil of the adjacent waste.

	A	B
Organic matter . . . . .	16.6	43.1
Nitrogen . . . . .	.49	1.1
Potash (K <sub>2</sub> O) . . . . .	.43	.42
Phosphoric acid (P <sub>2</sub> O <sub>5</sub> ) . . . . .	.14	.14

The soil B is a thin peat over a bouldery loam, and somewhat wet. The smaller proportion of organic matter in A may be due to the portion reclaimed being originally less peaty, but it is also probable that it is to some extent the result of aeration consequent on tillage. Generally speaking, the thin peats are not extremely deficient in potash and phosphoric acid, although the availability is rather low. In all the Carnarvonshire peats calcium carbonate is entirely lacking.

It will at once be recognised that this system of scattered quarrymen's holdings is in essence the 'garden city' idea—an excellent system, for, while



the country as a whole is enriched, the workman lives under conditions that make for health of body, of mind, and of morals—such a system as this ought to be encouraged to the utmost. Alas! our 'enlightened' economic system has brought all this kind of work to a standstill, and quarrymen are more and more crowded into squalid streets of small, gardenless houses at the bottom of narrow valleys, where they are tempted to spend their money and spare time in cinemas and public-houses. This change is primarily due to the fact that all improvements are penalised by increases of rents and of rates, and the latter are generally heavier proportionately on small holdings than on large farms. This is one of the ways in which we encourage our people to compete with German agriculture!

II. *Thin Peats at Lower Altitudes* (200 to 400 feet).—Of these there are numerous very extensive tracts, especially between the Moel Hebog range and The Rivals, where one could walk the greater part of the distance on this kind of soil. The flora is similar to that of the hill peatlands, but a little more varied. Thus, using the numbers 1–10 to indicate the scale of comparative frequency, we have in four typical localities :

- (a) *Calluna* 9, *Molinia* 6, *Festuca ovina* 4, *Juncus squarrosus* 4, Tormentil, &c.  
 (b) *Festuca ovina* 6, *Cynosurus* 2, *Plantago lanceolata* 1, *Scabiosa succisa* 3, *Carex panicea* 4, &c.

The next two localities were damper :

- (c) *Juncus effusus* 6, *Nardus* 5, *Festuca ovina* 5, *Carex panicea* 4, *Agrostis vulgaris* 3, *Molinia* 3, *Juncus squarrosus* 4, *Sphagnum* 2, Yorkshire Fog 2, Tormentil, *Scabiosa succisa*, *Thrinicia hirta*, &c.  
 (d) *Anthoxanthum* 6, *F. ovina* 3, *Luzula campestris* 3, Taraxacum, Lousewort, Cotton-grass, *Sphagnum*, &c.

The underlying boulder clay in this district is much less stony, but rather more sticky than in the foot-hills. It is of different origin, being the product of Northern glaciation, while the subsoil of the peat of Class I. is local material scraped down by Welsh glaciers. The peat over a large part of this area, notably in Lley, is extremely thin. Though there is good slope for drainage, this is rendered difficult by the unevenness of the surface of the boulder clay and the consequent numerous 'pockets,' each requiring separate draining. Certain parts cannot be efficiently dealt with except under a joint scheme, but in most cases it is difficult to get neighbouring landowners to co-operate for the common good. In a portion of the area there are numerous small holdings reclaimed within the last fifty or sixty years, and their flourishing condition shows what can be done, even with very ordinary methods. Most of the peaty tracts, however, go with the large farms adjacent to them. The farmers make no attempt to improve them; they are quite content with the rough grazing obtained from them in the summer. In one place this tract abuts on the old 'mountain wall,' above which there is a fairly large colony of small holders. Pointing to the peaty waste, we asked an old man, 'Is the land below as hopeless as it looks?' 'Oh, no!' said he, 'if one could only get some of it out of the clutches of the farmers one could turn it to very good use.'

It is worthy of note, as showing the importance of ownership and of security of tenure, that, in a number of cases where tenants have recently bought their farms, they have at once proceeded to drain and cultivate the waste portions of their land. There can be no doubt that much more of this beneficial work would be undertaken were there a sound scheme for extending financial assistance to farmers who lack the necessary capital.

III. *Deep Peat*.—This is of two kinds. The greater part is inland: it is over boulder clay and is very acid. In certain localities it is cut for fuel. Where this is not done it is generally reserved for grazing. The 'skin,' as the surface layer is called, is thick and tough; being firmly compacted *Molinia*, *Juncus squarrosus*, *Nardus*, *Festuca ovina*, and often *Salix herbacea* with other plants, it is strong enough to support the cattle grazing upon it. This peat type corresponds to the German 'Hochmoor'; from a few analyses it would appear to be very poor in potash, but moderately supplied with phosphoric acid.

Although it is well known to most farmers that the addition of mineral

matter to a peaty soil improves the herbage, it is rarely that this knowledge is acted upon. In one case a portion of peaty pasture looked far better than the rest: the farmer explained this as being the result of the application of road scrapings to the plot two years previously. On another farm some old mortar and gravel, after building, had been spread over a peaty tract. The parts not treated had the usual thick tufts of withered *Nardus*, sedges, and *Festuca ovina*, while the treated part had succulent, closely-grazed grass, with numerous patches a foot or more in diameter of white clover. Yet with this object-lesson before him the farmer had made no attempt to apply its teachings. In one case where the peat was not very deep it was suggested to the farmer that if he ploughed two furrows deep so as to bring up some of the boulder clay it might be beneficial. This he did, with the result that the crop of oats he obtained the following season was the best in the whole district.

Experiments have been carried out by the North Wales University College Agricultural Department in the use of mineral fertilisers for improving the herbage of peaty pastures: these show conclusively that phosphates, particularly slag and lime, encourage the growth of the finer grasses and of white clover, and the treated plots show the difference in the greater closeness with which they are grazed.

The second type of deep peat is found along the coast of Cardigan Bay, and in one or two bogs further inland, but at an altitude not much above sea-level. The peats appear to be of lacustrine or estuarine origin, and may be comparable to the German 'Niederungsmoor.' They differ, however, from peats of this class in other localities in their lack of calcium carbonate. Their vegetation is, however, slightly more varied than the 'Hochmoor' peats, suggesting less acidity. Some of them are half-cultivated; others yield only rough grazing, and at present no systematic attempts are made at draining and improving them, so that they only produce a fraction of what they are capable of under proper treatment. The greatest trouble is drainage. As mentioned above, this involves co-operation, together with some amount of compulsion to induce the farmers to keep the drains clear. So long as a farmer has dry, loamy soil on his farm, he will not trouble to improve the wetter portions. In one very instructive case a farmer gave up his 'rough grazing' to a small holder, who now has made out of the rushy, sedgy, reedy tract of wet peat an excellent little farm, producing heavy crops.

In most of the cases under discussion there are, close by, large banks of sand and gravel which might, at a very trifling cost, be utilised to ameliorate the peat and to correct its too great richness in organic matter. Strange to say, no attempt is ever made to carry out this obvious method of improvement. As for any of the special methods employed on the Continent, such as the Rimpau system, trenching, &c., it is needless to say that they are quite unknown in the district.

In conclusion, we maintain that, though the extensive peaty areas in the county are very acid and cold, and, as such, inferior to ordinary loams, they can still be made productive. It is evident that before they can be satisfactorily tackled some amount of experimental work must be done. Investigations should be carried out, partly on the lines of the Continental work, and partly on lines which suggest themselves to the local scientific workers. It is to be regretted that up to the present we have very few experiments on peat in Britain.

Much might be done at once in the light of knowledge at present available. Such improvements need not consist of large schemes. The cultivator could try to effect improvements on his patch of waste, bearing in mind the chief needs for amelioration:

1. Thorough drainage.
2. Addition of inorganic matter to correct excess of organic matter (on deep peats).
3. Correction of acidity by use of lime or ground limestone.
4. Addition of plant food—chiefly phosphates.

The obstacles to improvement are to a great extent economic. Some of them have already been mentioned: there are others, such as the high cost of labour, the want of recognition of the value of land, and the lack of organised assistance

from the Government. To some extent the evil is consequent on the peculiarities of rural human nature, which, without being definitely opposed to progress and sceptical as to the possibilities of improvement, possesses an inertia of incredible magnitude. It is to be regretted that this inertia in agricultural matters is not confined to the cultivators of the soil, but is equally evident, and probably less excusable, in the landowning class. When one compares the active enthusiasm of this class in the closing years of the eighteenth century and the first half of the nineteenth with present-day indifference, it would be difficult to resist a feeling of pessimism if there were not some signs of an increasing interest in rural affairs on the part of landowners. It is not so much that landlords are oppressive in the economic relation as that, instead of initiating and encouraging schemes of improvement, they stand aloof and show no interest in the problem beyond receiving their rents; or, still worse, by their adherence to the worst features of an outworn system, they discourage all attempts at reclamation. Not long ago we were invited to see some hill farms that had been bought a few years previously by a gentleman not of the landowning class. The new owner had been supplying his tenants with slag and other fertilisers, and with drain-pipes; he paid them bonuses on work done in blasting and removing boulders and in clearing wild land of bracken and hawthorn and gorse; he sought expert advice as to the treatment of certain local problems, and he communicated the knowledge to the tenants, with the result that hay crops were six times heavier than formerly, grazing areas were extended, and the land itself had quadrupled its value. From the hillside which was thus laboriously being improved one looked down on wide parklands, where all the wide, smooth ground—the best land in the neighbourhood—was in grass; this was let by auction every year and the hay carted off, and this gradually impoverished land had not received an ounce of fertiliser in forty years. The owner does not live there, for the 'house' is in ruins, and there is not the consolation (?) of good shooting—it seems to be a case of sheer indifference. Not only this, but landlords are often obstructive—they refuse to sell waste land at reasonable prices for reclamation, and in many cases they have refused to agree on conditions that would have made possible large schemes for arterial drainage and pumping.

On some of the thinner soils timber-growing might succeed. Even if this were not possible as a commercial proposition, the shelter afforded by belts of timber would be of immense service to the cultivator, and other indirect benefits might also accrue. Hitherto it has been impossible to get anything done on the lines indicated; it is to be hoped that after the war, with the aid of the Development Commissioners, a more fruitful policy will be adopted.

Lastly, we hope that the authorities will take up a scheme of small holdings which depends not on the taking of already well-cultivated land and giving it to inexperienced men, but on the gradual improvement of the thousands of acres of land now lying waste. Assistance should be forthcoming towards the initial expenses, and the use of the land free of rent and rates should be guaranteed for a number of years. In a word, men should be *encouraged* to improve the land instead of being penalised for it. Far more use should be made of existing facilities for agricultural education, and a well-considered scheme of extension *classes* (not mere popular lectures) should be instituted where special methods and the principles underlying them should be explained. Most important in this connection would be the extension of facilities and equipment for research in local problems.

### 3. *On Afforestation after the War.*

*By Sir JOHN M. STIRLING-MAXWELL, Bart.*

The author remarked on the difficulty experienced in the importation of timber during the war. The consumption of timber in military operations alone was tremendous, and our dependence on foreign countries was a heavy handicap. The bulk of our supplies were drawn from virgin forests abroad. Every year the demand increased, prices rose, and quality deteriorated. He was sanguine enough to believe that the planter in England would get his money back; but

we must have forests even though afforestation were not a profitable enterprise. We could not become a self-supporting country. We should rather aim at making the Empire as a whole self-supporting, contenting ourselves in the British Isles with the provision of sufficient timber to last us in emergency for five years.

In the discussion which followed, Dr. A. W. BORTHWICK emphasised the importance of educational work in training those engaged in forestry. This must be carried out in adequately staffed and equipped institutions.

Professor SOMERVILLE pleaded for effective Government action, and drew a vivid picture of the delays to progress as a result of inaction on the part of the Government and the various hindrances which were put in the way of advance.

Mr. MIDDLETON, as representing a Government Department, thought Professor Somerville a little severe. It was necessary to examine projects before they were embarked upon, and he pleaded the necessity of the preliminary survey which Professor Somerville had deprecated.

---

FRIDAY, SEPTEMBER 8.

The following business was transacted :—

1. *Discussion on the Bearing of Botanical Science on Coal.*

The discussion was opened by Dr. MARIE STOPES, who laid emphasis on the importance of the collaboration of palæobotanist, chemist, and geologist in answering the three chief questions about coal: what it is; where it is; and how it may best be used. A very wide and also very detailed knowledge of *all* fossil plants, not only the attractive or specially interesting ones, is requisite. Parts of plants generally ignored by botanists dealing with the recent flora are often the key to knowledge of fossil plants—fragments of angiospermic wood, for example, of which a systematised knowledge in recent families is urgently needed. It may be said that for the discovery of *where* coal is a knowledge of *species* and their outward characteristics is necessary; while for the discovery of *what* it is and how it may best be used a knowledge of tissues and special internal cell structures may prove of most value. Already tentative researches show the possibility of particular by-products from coal being associated with definite *portions* of plants.

Owing to the fact that the coal of this country was nearly all carboniferous in age, an idea seems prevalent that the study of fossil plants of other epochs has no bearing on the coal question. This is very mistaken if we look at things imperially, for the coal supplies of parts of our Empire are of differing geological ages—*e.g.* the coal in India is nearly all either of Tertiary or 'Glossopteris-flora' age, while Canada has vast Cretaceous resources. This justifies the claim that every branch of palæobotanical study may have its bearing on some aspect of the coal question in one part of our Empire or another. Though something has been done in studying coal in sections, a much more intensive study is needed, and methods are wanted for investigating it without sections—*e.g.* when it is already finely powdered. Reference was made to the enlightened encouragement and employment by the State of specially trained palæobotanists in a number of the leading countries.

Professor WEISS referred to the recent advance in the preparation of microscopical slides exhibiting the structure of coal, and referred to the work of Mr. James Lomax, who had made an extensive microscopical investigation of various portions of coal seams, from which we learnt that certain portions of a seam are much richer in spores than others. The presence or absence of these spores makes a material difference in the chemical nature of various portions of a seam, and while some of the coal may be more suitable for household use, other portions may be more suitable for the manufacture of gas and coke. It is important, therefore, that all seams should be systematically investigated both microscopically and chemically, so that the coal may be put to the best use.

Professor A. C. SEWARD was of the opinion that, from the economic point of view, the chemical investigation of coal was of greater importance than the purely botanical examination, the results of which, he was afraid, would, from a utilitarian standpoint, be comparatively meagre.

## 2. Discussion on the Collection and Cultivation of Medicinal Plants.

The discussion was introduced by Professor H. G. GREENISH, of the Pharmaceutical Society of Great Britain.

After pointing out the shortage which had been produced by the state of war, and to which attention had been drawn so early as 1914 by the Board of Agriculture, he proceeded to give an account of the efforts that had been made to remedy this by fostering home production. In the autumn of 1915 the Herb Growing Association, which had sprung into existence for this purpose, made serious attempts to organise on co-operative lines, but they had the misfortune to lose their drying-shed by fire, and the Central Committee of the National Patriotic Organisation came forward to endeavour to place the new industry on a sound basis.

To this end a circular letter was issued, urging landowners to devote a portion of their land to medicinal plants, and a leaflet with lists of plants and hints for drying, &c. A conference was then held, at which the Central Committee, the Herb Growing Association, and the Agricultural Organisation Society were represented, and as a result a scheme has been drafted for the establishment of the herb industry on a proper footing.

Only the future can show whether this industry can be made a financial success, but, notwithstanding the pessimistic views which have been expressed, Professor Greenish was of the opinion that the high quality of the home-grown and dried article would command a price sufficient to warrant the trial. There is scope also for research and experiment on the production of plants of higher yield or greater medicinal intensity.

The PRESIDENT then read a paper sent by Mr. E. M. HOLMES, F.L.S., F.E.S., also of the Pharmaceutical Society of Great Britain, on the cultivation of medicinal plants and the collection of wild herbs in Britain.

The author suggested the collection of herbs by instructed children, the establishment of public drying-houses, and the *cultivation* of certain plants, Belladonna, Henbane, Digitalis, in the particular place in which they flourish.

The industry can only be extended to an export trade by establishing the *superiority* of the British-grown article. The Colonies are attempting to grow their own herbs on account of the inferior material exported to them from this country.

From the scientific point of view, which is naturally that of the British Association, there are several matters in connection with the cultivation of medicinal plants that deserve serious consideration.

1. The possible improvement in the alkaloidal value of the plants.
2. The possible improvement in the yield of essential oils, and especially the increased percentage of the more valuable constituents of the oils.
3. The most favourable conditions of cultivation for each particular species.

Some experiments have been already made by the Agricultural Departments in the United States, in Germany, Austria, and other countries on these lines, but two mistakes have been made by these Departments :

(a) They have not sought the best outside expert advice.

(b) They have published too soon such results as they have obtained, on a small scale, without comparing them with results obtained elsewhere by practical men working on a large scale with the plants, and without stating the comparative conditions of soil, climate, and general environment.

Thus an American experimentalist states that the Biennial Henbane does not revert to the annual form, whereas I could show him in my own ground all stages between the two in different soils and with different treatment.

1. With regard to the possible improvements in the alkaloidal value of important medicinal plants, I may mention a few of the points that seem to me to demand careful experiments.

(a) The ascertaining the ingredients of the ash when the plant is calcined, as showing what the plant actually removes from the soil, and the consequent necessity of replacing the loss of these ingredients.

(b) The relation of moisture and good tilth (*i.e.*, soil kept porous and absorbent by the presence of decayed animal or vegetable matter, or by the use of coarse sand or breeze for clayey soils) to the vigour of the plant.

(c) The effect of exposure to wind and sunlight.

It will be understood that vigorous vegetation may be due to abundance of moisture, and that the amount of alkaloid or essential oil may seem greater or less in proportion to the succulence of the foliage, so that dwarfed growth may be mistakenly supposed to indicate a higher percentage of either alkaloid or essential oil. But it must not be forgotten that, unless the conditions for healthy growth are attended to, the plants soon become a prey to disease, and what is apparently gained in produce is lost in the expense of repeated replanting of the ground necessitated by disease.

(d) Another point is the selection of particular individuals for improvement of the species. In a field of cultivated herbs there will always be some that show more vigorous growth, deeper green colour, and an aspect of good health. These plants should be selected for analysis to see if their alkaloidal value is different from or superior to the average amount, and the seed of the first-developed capsules of healthy and vigorous plants should be saved for propagation. The conditions of the soil in the spot where these particular plants have grown should be recorded.

(e) Yet another point is the observation of various forms, varieties, or hybrids that occur under cultivation, and their separate cultivation for experimental purposes. It is these that have much to do with success.

Thus the Japanese menthol plant occurs in several varieties. The first that was imported into this country did not yield anything like the percentage of menthol that the Japanese stated was to be obtained, and it is only lately that the best variety has been brought to Europe, *i.e.*, the kind that yields the full amount of menthol.

The English peppermint plant yields the highest-priced oil that is obtainable in any country, and I have shown<sup>1</sup> that this is due to the fact that the French and American plants belong to different varieties of *Mentha piperita* from the English plant, and that the Chinese and Japanese belong to another species.

The best variety of Angelica in cultivation is grown in Saxony, apparently in micaceous soil, and the most highly prized caraway is grown in the North of Russia.

These might be experimented with in this country to ascertain if, under conditions found or obtainable here, these varieties would retain their peculiarities.

There are about twenty-four varieties of *Aconitum Napellus*, but these have never been separately cultivated to ascertain which is the best variety for use in medicine.

The chamomile needs similar experimentation as regards its volatile oil. There is a variety of *Anthemis nobilis* var. *b. floscula* which has a specially strong odour, but it has not, that I am aware of, yet been cultivated for the oil, although it might prove superior to any of the forms under commercial cultivation.

The ordinary double-flowered chamomile easily reverts under cultivation to the single form, but the conditions that cause it and the means of preventing it have not, I believe, as yet been published.

I will not at present refer to the foreign cultivation of medicinal plants, save to allude to the fact that several important plants, such as the Siam benzoin tree, the insect-powder plant, and the best Chinese rhubarb plant, deserve the attention of our Colonies.

Sir SYDNEY OLIVIER, Secretary of the Board of Agriculture and Fisheries, observed that the problem of supplying raw materials for drugs during the early part of the war had had to be dealt with as a matter of emergency, and the co-operation of all persons who are willing to help in it had been sought far and wide. Such voluntary and unorganised effort, however, could not suffice to

<sup>1</sup> *Perfumery and Essential Oil Record*, vol. iii., p. 10.

supply the needs of the drug market continuously, and under normal conditions. If, therefore, Great Britain was to be made self-supporting in regard to the principal lines of medicinal plants, it must be demonstrated that they could be grown by market gardeners as a remunerative crop. In that case there would be plenty of skilled professional horticulturists fully capable of providing the necessary supply. Assistance might have to be given to them in regard to the preparation of their material so that a uniform sample could be supplied to the wholesale dealers. As large quantities of the principal drugs, belladonna, henbane, &c., are already grown in this country by pharmaceutical manufacturers, it appeared reasonable to expect that the country could supply itself in this manner. But it appeared desirable that there should be more co-operation and organisation between the various agencies which were now interesting themselves in this matter.

MISS SAUNDERS pointed out the need for co-operation between the breeder and the chemist. She asked Professor Greenish if the frog method was still employed for the assay of digitalin, and what quantity of fresh leaves was required for comparative assays.

MR. CLARIDGE DRUCE considered that the cultivation of drugs for the British market should be in the hands or under the control of those having a practical knowledge of a highly technical industry, since the difference between profit and loss depended upon such knowledge. He did not think, except in the case perhaps of a few plants, that school children could be advantageously employed in herb collecting.

DR. E. N. THOMAS raised the question of the relative merit, in certain cases, of extraction from dried and from fresh leaves.

PROFESSOR WEISS supported the opinion of Sir Sydney Olivier that the cultivation of drugs could only be placed upon a satisfactory basis if the industry became specialised, and only the most remunerative varieties were grown. He referred to the experimental work which had been carried out in America on the effects of selection in the cultivation of belladonna.<sup>2</sup> It was essential that similar experiments should be carried out in the United Kingdom on all important medicinal plants with regard to their richness in alkaloids and other specific substances. The botanical departments of the various universities and colleges would, without doubt, be ready to co-operate in this matter with the Board of Agriculture.

THE PRESIDENT thanked the visitors to the Section most cordially for their kindness in contributing to so interesting and fruitful a discussion.

3. *Are Endemics the Oldest or the Youngest Species in a Country?*  
By Dr. J. C. WILLIS.

4. *Geographical Distribution of the Compositæ.*<sup>3</sup> By J. SMALL.

5. *The Origin and Fate of Salt-marsh 'Pans.'*<sup>4</sup>  
By Professor R. H. YAPP, M.A.

6. *A Contribution to the Plant Geography and Flora of the Arfak Mountains in Dutch N.W. New Guinea.*<sup>5</sup> By Miss L. S. GIBBS,  
F.L.S., F.R.M.S.

The author's chief collecting area was in the vicinity of the two small Angi lakes, situated at an altitude of 7,000 and 8,000 feet respectively, on the southern

<sup>2</sup> Bull. No. 306, United States Department of Agriculture.

<sup>3</sup> See *Pharm. Jour.*, December 1916-February 1917.

<sup>4</sup> A full account of the work dealt with is included in a paper on 'The Salt-marshes of the Dovey Estuary,' by R. H. Yapp and D. Johns; see *Journal of Ecology*, vol. iv., part iii., 1916.

<sup>5</sup> Published by Taylor & Francis, Red Lion Court, Fleet Street, E.C.

portion of the Arfak. Previous botanical collections in these mountains have been made by Drs. Beccari and Gjellerup.

*General Plant Formations.*—Access to the lakes is from the coast, of which only the immediate shore line is sparsely inhabited. A huge intervening low-lying belt of sago swamps and high forest, growing on sterile 'korang' or coral limestone, extends to the lower foot-hills of the Arfak. This tract of country, intersected by the alluvial terraces and large inundation areas of the rivers, which pour down from the mountains in the rainy season, is devoid of inhabitants and suggests very recent elevation.

Native houses are first met with at about 2,000 feet on the subsidiary spurs and lower ranges. From thence upwards, on the slopes and crests of the ridges, there is evidence of extensive cultivation, past and present. At about 7,000 feet on the crest of the main range human habitation again ceases, and a zone of small virgin mountain forest obtains to 9,000 feet, the limit of the range. This small forest, from 8–9,000 feet moss-grown to mossy in character, is chiefly marked by coniferous trees of *Dacrydium*, *Phyllocladus*, *Podocarpus*, and *Libocedrus* sp. In the larger forest of the same type which clothes the sheltered slopes of the lakes, groups of a handsome *Araucaria* are conspicuous.

Open spaces break this prevailing forest in parts along the ridges. These are either natural landslips of loose granite, gravel, or small artificial clearings made by the Papuans for rest and camping purposes. Where this clearing occurs over larger areas, on exposed plateau summits at about 9,000 feet, a xerophytic, open type of what may be called a *Claydonia Association* is found—*Myrmecodia*, *Hydnophytum*, prostrate or stunted shrubs with herbaceous plants, being dotted on a lichen-covered surface. To a certain extent marshland extends round the margin of the lakes, where splendid *Rhododendrons*, *Zingiberaceae* sp., and fine clumps of orchids formed splashes of brilliant colouring.

The shores of both the lakes are inhabited by small Alfuro or mountain tribes.

Phytogeographical results may be summarised as follows:—

1. *Wide distribution in New Guinea of endemic mountain types.*—Not only have species common to the Arfak proved identical with several collected recently by Kloss on the Utkwa Expedition to Mount Carstenz in the S.W., but also new species have been established in new genera or in genera first recorded for New Guinea on that occasion. The same results apply to the mountains of the N.E. and the S.E., for, amongst other striking instances, *Libocedrus*, already known from both regions, is now established for the N.W. as well, while two new species of *Didiscus* link up the Arfak with the Owen Stanley range, on which one species of this genus was already known.

2. *Further evidence of New Guinea as the centre of distribution for many so-called Australian and also Polynesian types.*—This fact is a marked feature of recent German and Dutch exploration, and has been emphasised by the well-known botanists who have worked out those results. To quote only a few examples on the present occasion, *Hibbertia*, a genus hitherto supposed to be limited to Australia and New Caledonia, is represented in the Arfak by a species closely allied to the Australian *H. volubilis*; and the occurrence of *Putersonia* and *Centrolepis* connects New Guinea both with Australia and with the summit of Kinabalu, in North Borneo, and Mount Halcon, in the Philippines, while *Centrolepis* is also known from South China. Both genera are new to the New Guinea flora.

*Systematic results.*—These comprise several new genera, whilst a large proportion of the plants collected have proved new to science. Amongst the latter, a *Dacrydium*, *Libocedrus*, and *Kentia* sp. are perhaps the most interesting. Myrtaceae, Araliaceae, Ericaceae, Vacciniaceae, and Orchidaceae were the natural orders most largely represented.

Collections made round Manokoeari (Dorei Bay), on some of the islands along the coast, and at Humboldt Bay have been separately enumerated, as no two species proved common to both mountain and coast flora. Though many new plants and interesting new records are included in this list, the larger portion naturally comprises better-known Malayan types, though wide endemic distribution is again emphasised.



7. *Survey Work near Bellingham.*<sup>6</sup>  
By Miss CHARLOTTE E. C. MEASHAM.

---

8. *On the Movements executed by Young Fern Fronds, with especial reference to Geotropism.* By Miss T. L. PRANKERD.

Young fern fronds are capable of at least seven types of movement—viz. geotropic, heliotropic, epinastic, nutational, autotropic, thigmotropic, and the sagging due to weight. These are exhibited to a greater or less degree in the three phases into which the life-history of a fern frond falls, both morphologically and cytologically.

The rate of migration of the chlorostoliths and the reaction time are much greater than those corresponding for the Angiosperm, and the former is decreased by severance of the frond.

The loss of geotropic irritability corresponds roughly (probably accurately) with the disappearance of the statenchyma during the second phase of existence while the frond is still capable of growth.

---

9. *On the Distribution of Starch in the Branches of Trees, and its Bearing on the Statolith Theory.* By Miss T. L. PRANKERD.

*Facts.*—Starch is almost always to be found in the buds and twigs of trees in the winter, and is invariably embedded in the protoplasm.

In the spring, before the buds open, the starch content increases, and in certain of the cells of the stem the grains always become free to fall—*i.e.*, form statoliths. As the bud opens the contained starch is gradually used up, except that in the stelar sheath of the developing stem, which is converted into statoliths.

In the summer, statoliths are developed in the appendicular organs, and die away in the stems remote from these. Behaviour of trophic starch is variable.

Production of autumn statoliths is under investigation.

*Theory.*—On the whole the statolith theory derives some measure of support from these facts, in that:—

- (1) Statoliths are produced in spring, and are absent in winter and in the older parts of the stem.
- (2) Statolith starch is constant in time and place; trophic starch is variable in both, especially in the former.
- (3) The degree of development of the statolith apparatus shows some amount of correspondence with geotropic activity, whether comparison be made *inter se*, or the group as a whole be compared with other biological groups.

<sup>6</sup> To be published in *The Vasculum*.

---

## SECTION L.—EDUCATIONAL SCIENCE.

PRESIDENT OF THE SECTION: REV. W. TEMPLE, M.A.

---

WEDNESDAY, SEPTEMBER 6.

The President delivered the following Address:—

It is a great responsibility, as it is a great honour, to be allowed the opportunity of delivering the Presidential Address to the Education Section of the British Association this year. The whole subject of education is more before the public mind than it has been for a generation at least, and one is tempted, therefore, to range over the whole field. I shall indeed range pretty far, but of course an individual's opinions are only of real value so far as they reflect at least some experience of his own. My experience has been entirely with education of the secondary school and University type, and with the effort, of which I shall speak incidentally, to supply University teaching to adult working men and women; this is indeed an instance of the University type of education. Of elementary schools, which I suppose constitute, for the present at least, the main part of our problem, I know nothing directly and very little indirectly. But I see two things with regard to them: first, that all reform is conditional upon our securing smaller classes; and, secondly, that the elementary schools ought not to be the most important part of our English problem, for we ought to be turning our attention to the building up of an adequate secondary system. It is in the sphere of secondary education that our whole equipment is most conspicuously and lamentably deficient.

One other word of introduction. The present interest of Englishmen in education is partly due to the fact that they are impressed by German thoroughness. Now let there be no mistake. The war has shown the effectiveness of German education in certain departments of life, but it has shown not only its ineffectiveness but its grotesque absurdity in regard to other departments of life, and those the departments which are, even in a political sense, the most important. In the organisation of material resources Germany has won well-merited admiration, but in regard to moral conduct, and with regard to all that art of dealing with other men and other nations which is closely allied to moral conduct, she has won for herself the horror of the civilised world. If you take the whole result, and ask whether we prefer German or English education, I, at any rate, should not hesitate in my reply. With all its faults, English education is a thing generically superior to the German. It is to perfect our own, and not to imitate theirs, that we must now exert ourselves. And so I turn to the discussion of some parts of this task.

There is a great deal of public interest at the present time, and very nearly as much mental confusion, with regard to education generally, and especially with regard to the place of technical training in education. The discussion in the public Press and elsewhere follows the lines of a number of cross-divisions. We sometimes have the division into literary and scientific

education, sometimes the division into general and technical; and there are those again who confuse these two divisions.

It is worth while, perhaps, to point out the particular confusions which are thus involved. There is no contrast in principle between a literary and a scientific education; the study of literature is a mere dabbling with amusements if it is not a scientific study. The real distinction, at which one only hints, concerns not the method of inquiry but the subject considered. It is the distinction between the study of man and the study of the physical universe; and as soon as this is clearly realised it becomes apparent that no education can pretend to completeness at all which does not in a very considerable degree, at least, cover both fields. Human faculty being what it is, the time available is for most people too short to make possible a thorough study of both human and natural science, which we may take to designate the inquiry into the behaviour of man and the inquiry into the behaviour of the physical world. But an education which leaves either entirely out of sight, and indeed which fails to implant in the mind the governing principles and ideas of both, can hardly be said to deserve the name of education at all.

Before pursuing this theme it is worth while to turn for a moment to the other distinction, which, as I have said, is sometimes identified with this. Here, again, the principle of the distinction is false. A general education must include, if it is to be truly general, the training of all the faculties, and this plainly covers manual work as well as mental work. Moreover, it appears to be established that manual work is for children the best means of developing brain faculty, and therefore has a direct value for the purely mental side of education.

Anyone who has taken any part in administering our present educational methods must surely be convinced that we are relying far too much upon books as our method of instruction. There are many people of very decided intelligence and capacity who can hardly learn anything at all out of books. One of the developments which we need is the far freer use of manual and productive work as a means of education in the strictest sense; as a means, that is, of developing human faculty quite irrespective of the practical or commercial value of such faculty when developed.

But here again, as in the former case, there is, underlying the false distinction, a real distinction between education whose aim is the employment of leisure, and that whose aim is the practical work of life. But inasmuch as work and leisure are both of them essential and necessary parts of human life, it is clear that the distinction, though quite real, ought not to be allowed to become a contradiction, so that the dilemma can arise whether we are training people for work or for leisure; plainly we must aim at training them for both.

At this point it will assist the clearness of the subsequent discussion if we refer to yet one more distinction which arises out of what has already been said—namely, the distinction between technical education and technical instruction, if by the latter of these words I may be allowed to indicate the training which aims at supplying some specific skill quite irrespective of the general human development of the personality, and by the former phrase such a training in either physical science or its practical application as may be a real part of the development of an entire human being. If the words are used in this sense I should desire to say that technical instruction may be of commercial value, and should, for aught I know, be definitely encouraged or even enforced by the State for the sake of its commercial value. But it has nothing to do with education, and we, as interested in education, have nothing to do with it, except indeed this: That we need vehemently to protest against such early specialisation as may develop the wealth-producing capacities at the cost of dwarfing the human nature as a whole.

When we analyse the prevailing conceptions current in most educational discussion in the way in which I have attempted, it appears that there are two broad divisions of the subject, one concerned with the matter of study, and the other concerned with the educational needs of human nature. The former gives us the broad distinction of human studies and physical studies; the latter gives us the broad distinction of spiritual and intellectual. The confusion to which allusion has been made arises in large part from the natural tendency to identify these two methods of division, as though it could be said

that the study of man developed the spiritual but not the intellectual side of our nature, and physical studies the intellectual and not the spiritual. But the fact is that both of the main elements in human nature with which education is chiefly concerned can be developed by means of either of the two broad sections into which we have divided the possible subjects of study. The study of literature can be so conducted as to develop a scientific habit of mind, and natural science can be so studied as to expand the imagination and, through that, the sympathies.

There is indeed one side of human nature of which I have said nothing, namely, the physical; but though a complete education must concern itself with this, it is a part of the subject capable of separate treatment, and we may here omit it, only remarking that education is very vitally concerned to see that the physical condition is such as may be the basis for the intellectual and moral life. It is now a commonplace of the subject that it is impossible to teach, and indeed cruelty to try to teach, those who are hungry or who are over-tired. It is not always recognised, however, that, apart from physical condition at the time when teaching is given, vigorous intellectual work, and still more moral character, can hardly be expected when the physical system is either stunted or disproportionately developed. I suppose it is technically possible to extract perfect melody from a violin whose strings are not in tune, and for aught I know it may be strictly possible for a perfect character to work itself out upon the basis of an ill-developed physical system; but it is clear that the difficulty is for all practical purposes insuperable.

I am told that an inquiry made in our Industrial Schools and Reformatories has shown that those children who are most difficult from the point of view of discipline, and as to whose future in the matter of moral development there is least ground for hope, nearly always prove to be in some way physically under-developed or mis-developed. Certainly if the body is in a condition of instability we should expect the mind and soul to be correspondingly fretful and irritable. The whole matter therefore of physical health and development is one that is vital to education, not only as a part of education itself in the largest sense, but as a condition which must be satisfied before education in the narrower sense can satisfactorily do its work.

From this we may return to the two broad divisions of human personality which are the actual concern of education in the narrower sense—the spiritual and the intellectual. The spiritual side of human nature, the capacity for fellowship and for devotion, is best trained by the life of membership in a society. No instruction or study can take the place of this. This is the great inheritance that comes down to us, in England at any rate, from the Middle Ages. The side on which those great private institutions which are called Public Schools, and the older Universities, are particularly strong is the social life which is their most leading characteristic. As the personality begins to develop it requires some society of which it may be a member, other than the home on the one side and the nation on the other. The nation is clearly far too big for the child to realise, or indeed to possess any effective membership in it; and the home, though not too small, is yet unsuitable in one respect, namely, that it is bound to be too much under the direction of the parents. Where life in a school-room is possible and where there is a large family to share that life, some of the conditions which we require are present, but what is needed is a society which shall indeed be under general supervision but of which the members actually determine the character and life, so that each feels that he is a member of this community in the fullest sense, that its welfare depends upon his loyalty, while his welfare depends upon its general character. I confess that I doubt the possibility of securing this fully realised membership otherwise than in a boarding school, but here I speak with great ignorance; at any rate I am sure that for the spiritual development of the rising generation we urgently need that corporate life in schools which the so-called Public Schools possess in so large a measure. Every member of one of these schools, or of one of our older Universities, knows quite well that what has been most valuable to him in his training has been the whole life of the place, and not the specific teaching of the class-room or laboratory. It is probably true that the educational institutions which have especially cherished this ideal have

tended to be slack, as they have certainly been amateurish, with regard to the intellectual or scientific life; but they have maintained this fundamental principle, that the spiritual nature is best developed through life as a member of a society, and that a society of such a kind that the membership can be real and effective. Recent experiments, such as that of the 'Young Republic,' are carrying into new developments precisely this idea, and their success—for I think we may already pronounce them a success—is a great vindication of the idea itself. But for the supreme testimony to the value of this education we must turn to our colonial and imperial administration. There has been nothing to equal it in the history of the world. It has faults, of course, and some of them arise from just such an amateurishness as we have noticed in our Public Schools. Yet there has been the sense of 'fair-play,' the readiness to take whatever comes as part of the day's work, the absence of self-advertisement and personal 'push,' the capacity to take command and act with authority when called upon, which are the very qualities most developed by Public-School life and most vitally needed in the public servants of a world-wide Empire. The great evil has been that the boys of a Public School all come from one social class, so that, though their public spirit is keen, their horizon is very narrow and they do not see the need or even the opportunity to exercise public spirit except in the ways traditional in their class.

In order that this social life may exist in any real completeness it is necessary that its control should be in the hands of members of the school itself. There should, of course, be supervision by masters or mistresses, who can in case of necessity take complete charge and prevent the occurrence of disaster; but the normal life should be under the control of senior members of the community itself. This will involve the acceptance within that community of boy or girl standards, and this is wholesome. It is not desirable that the growing conscience should be perpetually confronted with standards which are forced upon it but which it does not accept; it should be left free to form and to follow its own judgment under the stimulus of wise leaders who, without impatience at its youthfulness, will yet guide it onward to fuller and fuller development. The things that are important to a child may often seem trivial to the adult, but they are genuinely important to the child, and provided that his growth is being encouraged, and not artificially arrested, it is quite right that at each stage he should take interest in those things that are appropriate to that stage. Moreover, when children are thrown into a social life of this kind they immediately exhibit the root principle of all morals, namely, the sense of membership in the community and of obligation to serve it. The community in question is a narrow one. The boy of fourteen on arriving at a Public School hardly regards himself as standing in any ethical relation, for instance, to the masters. If he can outwit them, that is just a score for him. So, for example, dishonest work, when the boy cheats in order to avoid punishment, is very leniently judged by his fellows; whereas precisely the same act, if done for the sake of gaining promotion over others, is regarded as disgraceful. The schoolmaster is often tempted to class both of these together under 'cheating,' because he does not realise that the latter is a sin against a community to which obligation is recognised, while the former is merely an act of hostility against a natural foe. But so it is; and there is no harm in it provided it is only a stage in development. After all, if Jael had treated Barak in the way in which she did treat Sisera, Deborah would not have sung her praises.

Now, one main activity of a society composed of children or adolescents will necessarily be found in games. This is partly because physical growth is one of the main businesses of life at that stage, and it is right that the growing boy or girl should delight in developing and exercising the physical faculties. But it is also because a game is felt to be more communal than school work. With work arranged as it now is, it inevitably follows that school work is regarded as being done for one's own sake, while the boy who plays hard is regarded as serving the community; he does it for his house or the school as much as for himself. I shall suggest in a moment that experience shows that by changes, which are otherwise desirable, with regard to school work itself a good deal of this difficulty may be overcome, but it will still remain true, at any rate with

boys, that games are the dominant interest, and athletic heroes more admired than boys of intellectual promise; and I desire to insist that this is a perfectly right thing provided only that the elders, whether parents or teachers, do not themselves adopt the boy's standard, and so fix it in the boy's mind, but while sympathising with the boyish interests yet constantly lead the mind forward to a truer perspective.

I have already said that we give too exclusive a place to books in school education. Many boys, not at all really stupid, are failures at school because they are bad at books. If manual work is given a larger place, it can be so arranged that the great moral difficulty about school work is removed—namely, its individualistic and competitive character. Co-operation cannot be carried far in book work. If a boy does the work of another, as I used when at Rugby to write all the Latin prose for the boys in the Army class in my house, he may benefit himself, but the others lose. Learning from books must be done by each for himself. But manual work can be done in teams, so that a large co-operative element comes in, which is of great value as a training for citizenship.

It is possible to do something of this sort with regard to book work. At Repton a challenge-shield is at this time being presented, to be held by the house whose members together gain most marks according to a scheme which allots so many marks to a form prize, so many to a school prize, and so forth. This, in so far as it is successful in its aim, will bring the communal and co-operative spirit into the school work.

Before we leave this question of social life in the school or college and its influence as an instrument of spiritual education, let me point out what the adoption of this view involves. It requires in the first place that the school should have some individuality which ought to be expressed in its buildings and institutions. Improvement is already being made in this respect, but it is a monstrous crime that our big towns should be studded with vast barrack-like buildings which have no individuality whatever, and are merely, as it were, blocks of class-rooms and laboratories. It is much better to have a definitely ugly building than a building with no sort of feature. The school must be recognised as having a real life of its own in which its members must find their place; for instance, the monstrous regulation which allows a child to leave school on a certain day because his or her individual birthday is come, is full of the evil suggestion that the school exists for the child but has no claim upon it. Then, again, real playing-fields are needed in the neighbourhood of each school—not just an asphalt yard for the children to run about in, but grounds where organised games as part of the normal life of the school are possible. This is needed for physical growth, but it is also vitally needed for the production of that social spirit in the school which is the best of all trainings in good citizenship. The teachers in our elementary schools have in many cases done wonders in developing such a social spirit even under present conditions, but their good work is grievously hampered. I confess that unless such a social life can be developed I take comparatively little interest in the actual subjects of study; for I agree strongly with Plato that the primary aim of education is to fashion the inclinations and mould the growing will; and if this is not done, if there is either no real will developed at all, or a self-seeking anti-social will, I would rather that there should be no intellectual training. If a man is going to be a knave, for Heaven's sake let him also remain a fool.

In discussing the general atmosphere in which teaching is given, and the effect which by its constant though often unnoticed influence it produces upon the character, something must be said about the suggestion implied and offered by our present educational system, and the changes which are needed to remedy its evils. In the first place it is clear that the system rests on the belief that for most people all that is really required is a beggarly minimum. This is most of all apparent in that curious regulation which permits clever children who might profit by continued education to leave school earlier than others, while those who are more slow-witted and less likely to profit by prolonged education are kept at school for the full time. Clearly this regulation rests on and suggests the belief that there is a definable minimum to which all citizens should attain, but beyond which there is no vital necessity that they should pass. The point selected is unfortunate in the last degree, and that in two

ways. First, it releases children from the discipline of school just at the moment when discipline begins to be most essential. Down to the beginning of adolescence what we need is something that may more fitly be called supervision, and for myself I have great sympathy with those who hold that under a general supervision there should be the utmost possible freedom for the child. But with adolescence there comes a temporary chaos in the psychological make-up, and during that period there is an urgent need, not only for supervision, but expressly for discipline as that word is commonly understood, namely, the imposition of restraint, forcible if need be, in order that certain impulses may not break loose and destroy the harmony of the whole nature. But the school-leaving age is unfortunate in another respect also. We teach the child to read, and then send him away from school at a time when it is too early to have begun the training of his taste and judgment. We have made him a prey to all manner of chance influences but have not supplied him with the power of selection between these, or the means of resisting those which his better judgment condemns.

Something no doubt can be done by means of continuation classes provided that the time for them is taken out of the hours of employment and not added on to these; but nothing will really meet the case except an all-round raising of the school-age. And even then we still need to get away from the conception of a necessary minimum. What we have to aim at is the maximum attainable by each scholar, not the minimum that will make him a tolerable member of a civilised community. If we aim at a minimum that will be what most of the scholars also aim at. But how are we to make this change? The obvious method is a large system of exhibitions, maintenance grants, and the like, and we must welcome the proposals of the Consultative Committee presided over by Mr. Acland which were made public during July last. The proposals are better than the Report, which, as was pointed out in *'The Times Educational Supplement,'* is too much under German influence. But here, again, we come to another false suggestion. Any system of scholarships and exhibitions is false in principle, because it inevitably suggests to the child that it is to pursue its studies for the sake of its own advancement; the whole system coheres with the ideal of the educational ladder, by means of which men and women may climb from one section of society to another. Now it is undoubtedly true that the State is bound to secure for its own interest that brain-capacity wherever found shall be fully developed, and that if a child of a dock labourer has capacities fitting him to be a great statesman or a great artist it is for the public interest that these capacities should be fully developed. But we have also to remember that when by education you lift a child from one section of society to another, you expose him to one of the most insidious of all temptations, the temptation to despise his own people. And if once his native sympathies are thus broken up, it is unlikely that he will grow any more. An educational system which depends upon the ladder is in a fair way to train a nation of self-seekers. Our demand, and here I know that I am speaking for the whole community of labour, must be for the educational highway. Our aim must be, not chiefly to lift gifted individuals to positions of eminence, but to carry the whole mass of the people forward, even though it be but a comparatively little way. We want the whole system to be all the while suggesting that the child's faculties are being trained, not for its own advancement, but for the benefit which the community is to receive. And the right way to suggest this, while also securing for the community the maximum benefit, is, as it seems to me, nothing less than a system of free education from the elementary school to the University, which instead of offering exhibitions to enable those who are capable to proceed, will on the contrary exclude at certain wisely chosen stages those who are unable to benefit further by school education. At each of such stages there should be for those who are excluded from further advance some form of apprenticeship, and if the stage comes early this should be conducted as far as possible according to the principles of school life, with all its discipline as well as supervision.

But while I regard that as the ideal, of course I recognise that it cannot be achieved at once, and for the moment the line of advance must be that

suggested by Mr. Acland's Committee, supplemented by the greatest possible development of the tutorial-class system which owes its origin to the Workers' Educational Association, and for a full account of which I must refer to Mr. Mansbridge's book 'University Tutorial Classes.' The great feature of the tutorial-class system is its freedom from the spirit of competition and worldly self-advancement. It is an effort on the part of working people, with the help which the Universities have been nobly ready to supply, to equip themselves more perfectly to meet their responsibilities as citizens and as members of their own class. Within each tutorial class the element of competition is entirely absent, and any proposal which might have the indirect effect of introducing such a spirit is regarded by the whole movement with extreme anxiety and disfavour. By this system real University teaching is brought within the reach of the working people without their being drawn away from their own class. The Universities have responded nobly to the appeal, as I have said. But they simply cannot from their own resources meet the need which really exists. Either the State or private generosity must come to the help of the movement. The Board of Education has already shown its approval not only by a most valuable report which it has issued, but also by revising its code so as to enable it to give a higher grant to this work than was possible under the old regulations. But still more is needed. There must be munificent endowment of this work either by benefactors or by the State if the opportunity is to be genuinely taken.

The tutorial-class movement has made two important discoveries. The first is that there is a very great amount of literally first-class ability in the country going to waste for lack of opportunity. That many of us had formerly been convinced must be the case; it is now proved. The other discovery is this. A man who has had no secondary education at all can take up work of the University type when he is of full age if his mind has remained alert. I believe many continuation classes fail through ignorance or neglect of this fact. We always tend to restart the teaching process at the exact point which the student had reached when he left school. That is a mistake. The man or woman whose education ends at fourteen or thirteen, and who becomes desirous of more at twenty-one or later, has lost much in the way of knowledge; but if the mind has remained alert the development of faculty has gone on and the appropriate method of study is that of the University, not that of the secondary school. This is of the utmost importance. We shall not for many years to come secure such a raising of the school-age or such a re-modelling of our system as shall guarantee the full development of every child and adolescent. Thousands will continue to be dropped by our educational system at fifteen, if not sooner. Of course a healthy-minded boy who leaves school at fifteen means to have done with his books. He promptly throws them away unless he is Scotch, and then he sells them. But six or more years later he may wake up to his need for more knowledge and intellectual training. Our tendency has been to give him school teaching; that is wrong; he is of the age to which University teaching is adapted, and only in that will he find what he is wanting.

I turn now to problems connected with subjects of study. Provided there has been established such a social life as I have described, there will be less harm than otherwise resulting from some degree of specialisation in secondary schools. The students of different subjects will be mixing with one another, and will learn from one another a great deal of those subjects which they are not themselves definitely studying. Certainly one of the great advantages of the college system at the Universities is that it gathers together in very intimate social intercourse students of different subjects. It would be impossible for me, for example, to express what I owe to my intercourse with students of natural science during my time at Balliol in Oxford. My own study of natural science lasted for one term, during which I turned the age of thirteen. We rubbed glass rods on fur mats and then held them over strange instruments in which gold leaves behaved in a manner which I now forget, and that was all; but I venture to think that I have acquired sufficient knowledge of how scientists interpret the world to be of real service to me, and this I owe almost entirely to being a member of a college which contained



people who studied natural science while I was studying classical languages, ancient history, and philosophy. I believe that the influence in the other direction is still more important. At the present time there is a great denunciation of the prevalence of classical studies and a demand for education in natural science. But I remember a candidate for a scholarship in natural science who presented himself for examination while I was a Fellow of Queen's College, who had apparently not read a line of poetry, who knew absolutely no history at all, had never read a novel, nor even a magazine that was not scientific; he assured us with conscious pride that since he was thirteen he had read no printed matter except such as concerned natural science. An effort to engage him in conversation showed that his mind was very much what might be expected. He came from a day school, and had had very little intercourse with people engaged in the study of other pursuits. That is an extreme instance. But it is worth while just now to insist that specialisation in mathematics or natural science, if divorced entirely from the more humane studies, or from intercourse with those who are pursuing such studies, may be educationally disastrous in the last degree. Of course it is sometimes suggested, as I remarked earlier, that the study of natural science produces a scientific type of mind. But this is one form of the confusion to which I alluded at the outset, which results from our speaking of natural science by the general name of 'science.' The study of languages and history can be, and ought to be, just as scientific as the study of physics.

We may state the question perhaps in this way. In order that a man may live his life and discharge his responsibilities as a citizen he needs knowledge. What is the most important sort of knowledge to have? None can be put on a level with the knowledge of human nature. Whatever a man is going to do he will have to deal with his fellow-men and find his own place among them. This knowledge cannot be adequately obtained from books alone, and, as I have said already, training through membership in a social life is the best means to it. But it may be also fostered in a very high degree by what are called the humane studies: the study of the best that men have thought in philosophy, the study of their highest aspirations and deepest woes in literature, the study of their attempts and their achievements in history. This is the most serviceable of all scientific studies that a man can undertake. But it is no doubt true that we have allowed two evil things to happen. In the first place we have not sufficiently recognised the value of natural science in education, and, still more disastrous, we have tended to identify the study of the humanities with the study of the classical languages.

The upholders of the classics, taken as a group, have no one but themselves to blame if the studies in which they believe are an object of very general attack, for they have been defiant in manner and retrograde in practice. And yet the attack upon the classics is unintelligent. It is very noticeable that the most elaborate study which has ever been compiled of the British Empire, and of the problems which it must face in the near future, should find it necessary to begin its survey with an account of the civilisation of ancient Greece and Rome. I am referring, of course, to 'The Commonwealth of Nations,' by Mr. Lionel Curtis. European history and civilisation are indeed only intelligible in the whole sense of the word by means of some knowledge of those two ancient nations. And there is this great advantage in the study of Greece and Rome, that we can trace there the complete rise and fall of a particular system of civilisation. The modern system is not complete, perhaps it never will be. For that very reason it is impossible to see the events in a perspective determined by an apprehension of the whole. But the history of ancient Greece is a complete thing, so is the history of ancient Rome, and it is possible to study their thought and achievements with a perspective and proportion due to the fact that the whole is known to us. I am not saying that this is always done, for much time is too often spent on studying events which led to no appreciable result at all; but at least the thing is possible. The study of ancient Greece has this further advantage, that the ancient Greeks asked all the elementary questions of philosophy in the simplest form. All subsequent European thought is to some extent sophisticated, precisely because it takes up its problems where the Greek philosophers left them. It is

undoubtedly best for the student to begin at the beginning, and the beginning of European thought is to be found in the pages of Æschylus, Sophocles, and Euripides, of Plato and Aristotle, of Herodotus and Thucydides. But the study of these great literatures with their attendant history is largely ruined by two facts. One is that far more boys are driven into this study than will ever seriously profit by it, and for this Universities are on the whole to blame, though it is to be remembered that nearly all professional examinations make a fetish of elementary Latin, requiring not enough of it to be any kind of use, but quite enough to waste a great deal of the student's time. And the other ruinous fact is that we have continued a system appropriate to a time when there were few subjects to supply the place of mental gymnastics, and therefore use the history of two great peoples, and two noble literatures, for this menial office.

I should like to suggest that certain authors should be altogether excluded from the curriculum of schools. In the choice of authors for school reading it is always what a writer says, not how he says it, that should be considered. My list of condemned authors would certainly include Cicero and Demosthenes. Further, I would suggest that either some special part of the term, or some special author studied through the term, should be selected for close and grammatical study in classical forms, but that beyond this there should be a large amount of reading, for the preparation of which the use of a translation should not only be permitted but obligatory. Perhaps Cicero and Demosthenes might come in under the former heading as museums of idioms and grammatical constructions. Moreover, and to this I attach the utmost importance, composition should be entirely given up except at the very elementary stage where 'sentences' are necessary for the mastering of even elementary constructions; and again at the most advanced stage, where the pupils have reached a point at which it is clear that they can with advantage be carried forward some distance in pure scholarship. The amount of time that is wasted over Latin and Greek prose seems to me something entirely deplorable. To gain the whole of this time for reading or for history would be an incalculable boon. I know this is a heresy, and so I emphasise it. No doubt any mental grind brings some benefit. But I believe the time given to Latin and Greek prose is as near wasted as any time of tolerably hard work can be. The climax of horror is reached when boys are made to read a dull author because it will be good for their prose, or are not allowed to read a quite interesting author because it would be bad for their prose.

But, after all, the chief point that I wish to urge is that the classics are not the only available form of humane study. I should like to see an experiment conducted on the following lines. The staple of the school curriculum to be European history and English literature. At the bottom of the school there should be elementary Latin, which undoubtedly provides good mental gymnastics, and of course elementary mathematics and natural science. Perhaps also French, though of this I am more doubtful. Those boys who showed real facility in Latin should, if they so desired, begin to study Greek at about the age of sixteen or sixteen and a half. They should then have one term in which they would do very little except Greek. Experiments suggest that in forms consisting only of boys who have already shown some aptitude for a classical language, one term's concentrated study will bring them to the point reached by efforts of several years according to our present methods, and the devotion of a single term to this would not seriously interrupt the general course. There would not be a classical side and a modern side, for the staple study of the whole school would be history; but there would be, above the point indicated, divisions for Latin and Greek as there now are in classical schools for mathematics. These would have allotted to them all the hours on the time-table that were not required for the history and literature, for it is of no use, broadly speaking, to read classics after that time unless they are given almost the whole of the student's attention. The study of ancient civilisation, which is what the study of the classics ought to be, is itself something far too rich to come under any condemnation of specialism. Boys who do not take this classical course would take mathematics, science, and at least one modern language, the mathematics and the science being as far as possible combined;

specialisation either in the linguistic or the scientific branch would be encouraged in the highest departments. There would also, of course, be opportunity for specialisation in history by means of divisions which would provide a course of study supplementary to that which formed the staple of the school curriculum.

Meanwhile there is one serious evil which could be remedied at once. It is the business of the Universities to be the guardians and upholders of a true educational ideal against the natural utilitarianism of the man of affairs. By their scholarship system the Universities exercise a far-reaching influence on secondary schools. They give far more scholarships for classics than there are deserving candidates; they do a good deal for natural science and mathematics; they do something, though absurdly little, for history; but they practically do nothing at all for modern languages. To this branch of study they give no encouragement such as might help the schools to treat it in a truly educational way. I want to see boys and girls who study modern languages reading the great literatures which constitute the value of those languages as boys at the top of a classical side read Æschylus and Plato. But we shall not reach that without help from the Universities, and at present the Universities refuse their help.

But, after all, important as are the subjects of study and the machinery for pursuing them, all of this is subordinate to the spirit which should direct and inspire the whole. I say the less about this because it has been so admirably dealt with by Mr. Clutton-Brock in his recent little book 'The Ultimate Belief,' which I could wish that all my hearers would read. Broadly, however, my contention, like his, would be that the aim of education is primarily spiritual, and that there are three, and only three, primary aims of the spiritual life. These are Goodness, Truth, and Beauty. It must always be insisted that these are ends in themselves. School discipline must be so conducted as to suggest constantly that goodness of character is not to be sought as a means to happiness or any form of success, but as an end in itself. So much is commonly admitted though seldom acted on, but the same principle must be impressed with regard to Truth and Beauty. With regard to Truth, probably most educators already believe it but they are shy of appealing to it, and industry is recommended not as a means to the fulfilment of the spirit's destiny but as a means to success in life, or at best as a means to effective moral goodness. In the case of Beauty our education hardly recognises at all that it is an end, with the result that those whose spiritual activity most naturally takes this form find themselves in rebellion against the upholders of Truth, and still more against the upholders of Goodness.

There is danger at the present time that we are about to be plunged into great efforts for educational development resting on purely utilitarian motives. Such efforts may succeed for a time, but in the long run they are doomed to failure because they take their stand upon a lie. Beauty, Truth, and Goodness cannot in the end of the day be sought for the sake of anything beyond themselves, though it is true that innumerable benefits follow even the partial attainment of them. But the search is doomed from the outset if it is not concentrated upon them as themselves being the prize of the soul.

Now this contention that Beauty, Truth, and Goodness are ends in themselves, which is the characteristic mark of a truly spiritual faith, really implies that these three are a unity, and there is no way of making that unity intelligible except by faith in God as at once perfect Power and perfect Love. This is my last point. We are all agreed in desiring scientific education, but the method which we have followed for many years precludes our ever reaching such a goal. For to all intents and purposes we have said: Let us leave the existence of God an open question, and then be scientific about the rest. The thing cannot be done. The existence of God is not a matter of private opinion which can be added to other views of life and the world without making any difference. It either governs the whole of our thinking or else it is not really accepted at all. Consequently the scientific ideal of education is simply unattainable as long as this question is treated as an open one. There are two possible educational systems, each of which would be scientific at least in its spirit. One is the religious, the other is the atheistic. It will very

seriously affect the teaching of history, for example, whether or not we believe in a Divine Providence; if we do, it is absurd to teach history without reference to it. I am very likely to be told that this simply means that as the Being of God is itself not something susceptible of proof we are condemned for ever to unscientific methods in this respect, and, realising that, must set out to be as scientific as we can. But that I desire to deny. I desire that any scheme of education should state clearly whether belief in God is its governing principle or not. If it is not, that system of education is in its effect atheist, even though it is conducted in a school that has a chapel and compulsory services. But we can only have clear thinking, and it is for that I am now pleading, if we recognise that we must take our stand on one side or the other. The question cannot be left open because it is one which, if not answered in one way, answers itself in the other. If we teach history without reference to Providence, we also teach that Providence does not guide history. I am not exceedingly interested in the maintenance of religious instruction as something apart from the rest of education, as if religion could be one subject of study side by side with chemistry and mathematics. Of course it can be so studied, and that by an atheist as much as by a believer. The only religion worth having is one that colours and governs the whole of life and thought. If we wish to exclude this let us say so plainly and follow our principle scientifically. If on the other hand we believe that the religious view is right, then let us affirm that also, and teach every subject in the light of it. The only religious education which is going to stand the test of an alert criticism conducted by scientifically trained minds is not instruction given in certain isolated periods, but a presentation of the whole universe of being as filled with the Glory of God.

The only way to this goal is to secure that the training colleges are filled and inspired by living faith. The future teachers must learn the science of the spiritual world, which is called theology, in some degree at least—no outrageous demand if all citizens are to learn something of the science of the material world. They must be taught how to handle the documents at once appreciatively (which means reverently) and scientifically (which means critically). Above all, their whole study and training must be in the atmosphere of faith. The State training colleges virtually or entirely ignore all this side of things; I fear that partly owing to the crowding of the time-table and partly owing to rigidity of method the Church training colleges are in this matter far from efficient. I often marvel that the champions of religious education seem virtually to ignore training colleges, for it is clear that in them is the key to the whole position.

Beyond all questions, however, of method, or even of fundamental principle, there lies the supreme task of persuading the people of England, I will not say of Scotland, to believe in education, for it may be broadly said that the English people at present do not really believe in it at all. Of the three great aims of the spirit—Beauty, Goodness, and Truth—that with which education as organised by the State must mainly concern itself is Truth. It may, so to speak, make provision for the pursuit of the other two, but its main efforts must be concentrated, when once such provision is made, upon the training of the intellect, or, in other words, upon the pursuit of Truth. But the English people as a whole do not care about Truth. When an Englishman speaks of telling the truth he usually means saying what is in his mind quite irrespective of whether it is the truth or not. We are disposed to value knowledge only for results beyond itself, and for this reason, with the exception of a perhaps almost uniquely large number of distinguished individuals, we acquire as a nation singularly little knowledge either for the satisfaction of our intellects or for the practical work of the world. At the present time there is indeed a kind of flutter about education, but the discussions show that it has behind it very little enthusiasm for the Truth, and it will therefore fail even of its practical object, if indeed it does not as may be expected die down as quickly as it has sprung up. The main purpose of education may be summed up in the great phrase of St. Paul: 'Whatsoever things are true, whatsoever things are honourable, whatsoever things are just, whatsoever things are pure, whatsoever things are lovely, whatsoever things are of good

report, if there be any virtue, and if there be any praise, think on these things.' It should lift us above that material world, absorption in which is the occasion of all strife and enmity. For the material goods are at any given moment limited in amount, so that the more one has the less there is for others, and if all are aiming at these they are bound to be brought into conflict. Education should lift us to the pursuit of the spiritual goods—love, joy, peace, loyalty, beauty, knowledge; of which it is true to say that the more one has the more everyone else will have on that account. Such an education would save our nation from its divisions which weaken it far more than any deficiencies in technical skill, and would lift all the nations of the world that followed it to that plane of being where each would rejoice in bringing its contribution to the general weal, and none would seek an advantage that could only be won at a loss to humanity as a whole. That is a far-off goal; but it must be towards far-off goals and on lofty ideals that we set our aspiration, if out of the terrors of this time we are to win a result that shall be commensurate with the suffering through which we are passing.

Meanwhile there is in many quarters, and most conspicuously in the ranks of labour, a disinterested desire for knowledge as a real emancipation of the soul, which all who care for education should watch and help to the utmost of their power. It must be from the aspiration of the common people that the salvation of the people comes. Nothing that is really good can be imposed upon people by well-wishing superiors. In education, as in everything that concerns the spirit, freedom is the one condition of progress. It is for freedom that we are fighting in the war; it is for freedom that those who care for education are struggling at home; for there is nothing that so much hinders the effective freedom of our people as the fact that they are left without facilities for the whole development of their faculties. In the name of those who have died for the freedom of Europe, let us go forward to claim for this land of ours that spread of true education which shall be the chief guarantee of freedom to our children for ever.

The following Paper was then read :—

*The Place of Handicraft in Schools.* By J. G. LEGGE.

A few notes on the early history of manual instruction.—Importance of even a brief survey.—Impetus given to the movement towards handwork by Rousseau, Pestalozzi, and Basedow in latter part of eighteenth century.—The nineteenth century.—First administrative steps in England in the early 'eighties of last century.—The part played by the British Association, and Sir Philip Magnus's paper in 1886.—The fourfold argument in favour of handicraft, including domestic work in schools, (a) physiological, (b) psychological, (c) moral, and (d) social.—Increased importance which manual instruction will derive from experience of war.—Effect of continued education up to age of eighteen.—Danger of making this too much a period of text-book cram.—Association of physical exercise and drill with manual work.—Intimate connection of manual instruction and the teaching of science at early stages.—Supposed conflict between science and the Humanities.—Between the school workshop and the class-room.—These fears due to a misapprehension of terms, and of the distinction between principles and the application of principles, as in mathematics pure and applied.—Coming demand for trade schools, or pre-apprenticeship schools, or manual training high-schools.—Where are the instructors to be found? Probable dearth of men teachers in the next few years.—Necessity for men in boys' schools.—The possibility of finding new sources of supply.—Training of wounded soldiers, a fine type of men to introduce into our schools to act as instructors.—A suggested scheme for student-teachers, worked in connection with new trade schools, &c.—Danger of destruction of local initiative, local responsibility, by central bureaucracy bent not only on laying down general lines of policy, and supervising policy, but on administering every detail of that policy.—The hope of the future, the working out of our own salvation under control of an unambitious, unselfish, central authority, with some sense of humour, whose aim is guidance,

encouragement, and co-operation, not forcible feeding on a diet of codes and regulation.—Only by hard, honest, skilful, intelligent work, with a living element of spontaneity in it, hand-work as well as head-work of every kind possible to man, can we redeem our future as we should.

---

THURSDAY, SEPTEMBER 7.

The following business was transacted :—

1. *A Scheme of Secondary Education for Children.*  
By Mrs. T. W. WALLIS.

2. *The Present Position of Science in Secondary Schools.*  
By J. TALBOT.

3. *The Importance of Combining Literary and Scientific Subjects in the Course of General Education.* By Rev. H. B. GRAY, D.D.

The general principle sought to be enforced in this paper was that a due balance should be maintained between naturalistic studies on the one hand and literary studies on the other in the education of all boys up to a certain limit of age—which limit should vary in accordance with the age at which they are destined to end their school life altogether.

I. *The Preparatory School.*

To begin with the preparatory school, where children of the prosperous classes are generally educated.

The subjects to be taught may be summed up as follows :—

(a) English, to include reading aloud (with just emphasis and elocution) of simple literature.

(b) History grouped round lives and characters.

(c) Arithmetic, with mensuration.

(d) The elements of mechanics.

(e) Nature study on a gradually expanding scale from local to national environments.

(f) Geography on a modern and scientific basis.

(g) One modern language, which should be French.

(h) Manual training, to be taught for one-third of the weekly periods now spent in non-productive games, such games to be limited to three afternoons a week, while one afternoon at least should be devoted to physical training.

II. *The Continuation and the Technical Schools.*

These should be made compulsory on all boys up to the age of eighteen, on the plan known as the Cincinnati system, according to which two boys, pursuing the same trade, are paired, one pupil attending the school, and the other the works or shop, every alternate week.

III. *The Public and the Secondary Schools.*

For the purpose of dealing with the subject in hand, a distinction must be drawn between the (so-called) public school, where the leaving age ranges from seventeen to nineteen, and the secondary school, where it ranges from fifteen to sixteen. This distinction of name is in itself illogical, but the variation in the leaving age involves slightly different problems and therefore somewhat different treatment.

(a) In the public school the educational curriculum should, from the age of twelve or thirteen to sixteen, be conducted on the Grand Trunk principle. There should be no such line of demarcation as that now in vogue, known as 'the Classical and the Modern Sides.'

The subjects should be :—

1. Science—that is, the ascertained facts and principles of mechanics, chemistry, physics, biology, geography, and geology.

2. Mathematics, studied with a view both to their commercial utility and their applicability to scientific pursuits.

3. English Language and Literature, together with training in elocution and in composition. Easy précis-writing and essayship should form part of the course.

4. French, taught orally and practically, and with due regard to literature.

(b) In the secondary school the course should be the same as in the public schools till fourteen, and *after the age of fourteen*—

i. English, French, Science, and Mathematics, or, alternatively,

ii. English, French, one other modern language, and commercial mathematics.

As regards ii., Science will have been previously studied between twelve and fourteen.

The alternative courses i. and ii. are arranged so as to suit those boys who are entering on technical and commercial careers respectively.

(c) In the public schools, after the age of sixteen, specialisation could begin, and be organised as the boy is to enter

(a) The literary professions.

(b) i. The commercial professions.

(b) ii. The scientific professions.

(a) On the literary side, one or both ancient languages should be studied on a reformed method, while mathematics and science might be dropped.

(b) i. On the commercial side, one further modern language should be combined with French, according to the career which the pupil is likely to enter, but History and Economics should form part of the classical curriculum.

(b) ii. On the scientific side, one or two special branches of science should be pursued, adapted also to the pupil's future career.

The principles of biology should be a subject of study for all boys over sixteen, whether on the literary, the commercial, or the scientific side.

Finally, a graduated system of manual training for all boys in public and secondary schools should be insisted upon as part of the course, and should take up one-third of the hours now devoted to non-productive games, while one-third of such periods should be devoted to military drill.

It is necessary to insist upon the importance of a real educational touch between those who are training pupils of all grades and ages in literary and naturalistic studies respectively. There has hitherto been, specially in our public schools, an unnatural divorcement between the methods of the two, both in sentiment and practice. In the lower grades of education a teacher, equipped by his own school training with both kinds of knowledge, would apply scientific method to the teaching of languages, and literary expression to lectures on the natural sciences. There must be, in fact, no watertight compartments in knowledge on the part of teachers any more than on the part of pupils.

All that can be ventured here is that, if a balanced scheme of education, such as has been set forth in this paper, is carried out, it will bear its natural fruits in producing the right kind of teachers and the right kind of teaching in the following generation. This is as much as can safely be predicted.

---

4. *Science in the Universities.* By Principal W. H. HADOW.

---

5. *Science in relation to Industry.*<sup>1</sup> By Dr. E. F. ARMSTRONG.

---

<sup>1</sup> Published in full in *School World*, 1916, vol. xviii., pp. 366-368.

6. *Discussion on the Place of Science in the Education of Boys.*

7. *Science Training which should be given to Girls who propose to become Teachers of Domestic Craft or to devote themselves to a Domestic Life.* By MARY E. MARSDEN.

The influence of school education upon professional training is deep and far-reaching. The latter depends largely upon habits formed at school.

Success in professional training in Domestic Craft depends mainly upon manipulative skill, accuracy of work, and knowledge of Physics and Chemistry.

A knowledge of Mathematics, Physics, and Chemistry up to matriculation standard should have been attained at school by intending teachers of Domestic Craft.

The fundamental ideas of Physics and Chemistry play a much larger part in Housecraft than those gained from the study of any other science, *e.g.* Botany. The school course in Physics should include measurement and the general properties of matter and heat. The Chemistry course should include an outline of the chemistry of air and water, natural waters, hardness of waters, acids, alkalies and salts, chalk, carbon and its principal compounds, combustion and elementary chemical theory. If time permits, it is advisable for girls to study the outlines of the chemistry of such substances as common foodstuffs, soap, &c. In order to prove the necessity for the study of these subjects as a preliminary to a course of professional training, a brief outline is given of the science included in the Battersea Polytechnic Training Department for Teachers of Domestic Subjects.

The Physics course includes general measurement, specific gravity and heat, accuracy in observation and in measurement being one of the paramount aims. The Chemistry course comprises the chemistry of air and water, elementary chemical theory; the common acids, alkalies and salts; coal-gas, fuel; sugars, starch, alcohol; the study of the principal foodstuffs; textile fabrics, soap; the outlines of the bacteriology of the air, water, milk, meat; preservation and purification of foodstuffs; antiseptics and disinfectants. Much time could obviously be saved if the earlier portion of the work had been efficiently done in Secondary Schools. There are also additional courses in Experimental Cookery and Laundrywork, of which the object is mainly to apply the knowledge gained in Physics and Chemistry to practical Housecraft. Much importance is attached to the study of Hygiene, which is treated as a science based largely upon Physiology, Chemistry, Physics, and Bacteriology. The course includes personal, domestic, and public hygiene; infant feeding and care; the common physical and mental defects of children, &c.

For those students who show special aptitude for the scientific side of the training, an additional one-year course has been in operation for some years at Battersea Polytechnic. This course includes Physics, Chemistry, Bacteriology, Physiology and Hygiene, and the work is much more advanced than in the earlier course, both as regards pure Science and its application to Housecraft. Domestic Craft is full of possibilities for invention and research. It is an essential factor in the reconstruction which must follow after the war. Women must take their share if that reconstruction is to be accomplished, and in no sphere can they do so more adequately than in Domestic Craft. Efficiently trained women are necessary in order to spread the knowledge which will lead to the substitution of wise economy of time, labour, and money for the almost universal thriftlessness of English households, to check the appalling wastage of infant and child life, and to make it impossible for the present physical unfitness of so large a proportion of our adult population to be repeated in future generations.

8. *Science in the Education of Girls, particularly those hoping to be Medical Students.* By Dr. MARY H. WILLIAMS.

I. Why science teaching should become an integral part of the girl's education. Aim of education is to manufacture the best possible citizen; one with the highest moral standard and equipped with that special knowledge which shall enable her to do the work for which she is best fitted.



It is urged that languages teach perseverance: this is learned by 'sticking at' any branch of study. The Humanities may give a quality which we used to call 'culture,' but, if so, it can only be gained by those few who learn enough to read masterpieces in the original with ease. Sufficient knowledge of languages to give definition of language should be taught.

Science study is the best method of learning to weigh evidence. Investigating the evidence on which scientific statements are based induces a habit of mind afterwards invaluable.

## II. Order of choice of various branches of science.

1. First, Biology, because it has most bearing on every-day life; in Biology, I include Botany, Elementary Zoology, and Physiology.

(A) Mistakes are commonly made from ignorance of this subject: *e.g.* (a) in the interests of economy we are urged to forgo sugar, though it is a most important food; (b) the Daylight Saving Act, accepted as a war emergency measure, has been passed with no consideration of its possible pathological effects. It is seriously lessening the amount of sleep of the children, as they will not, or cannot, get to sleep in daylight.

(B) A knowledge of the origins of life in plants, protozoa, insects, birds, and mammals is essential, in order to give a rational, consecutive account of the origin of human life when our children begin to question us. Ignorance on this subject leads to harm.

2. Chemistry and the various branches of physics should be included so far as time permits. An elementary knowledge of the facts of heat, light, and electricity makes life more interesting, and a thorough knowledge of these subjects is needed for a medical student. Sufficient chemistry should be taught to make physiology intelligible.

III. Information concerning present amount of science teaching in various large girls' schools.

---

## 9. Discussion on the Place of Science in the Education of Girls.

---

FRIDAY, SEPTEMBER 8.

The following Reports were received:—

1. *Report on the Character, Work, and Maintenance of Museums.*

---

2. *Report on the Influence of School Books upon Eyesight.*

---

3. *Report on the Free-place System in Education.*

---

4. *Report on Popular Science Lectures.*—See Reports, p. 326.

---

5. *Report on the Mental and Physical Factors involved in Education.*  
See Reports, p. 307.

---

6. *Discussion on the Report on the Mental and Physical Factors involved in Education.*

---

## SECTION M.—AGRICULTURE.

PRESIDENT OF THE SECTION: E. J. RUSSELL, D.Sc.

WEDNESDAY, SEPTEMBER 6.

The President delivered the following Address:—

WE are met this year under peculiar conditions such as may never recur in our history. We have had a demonstration, more striking than ever before, of the vital part that agriculture plays in the life of the community; we have seen how in time of war the supply of food might easily become the factor determining the issue, and it is already clear that in time of peace a vigorous rural civilisation is indispensable to the stability of the social structure of the nation.

I am going to deal to-day with the possibilities and the prospects of increased crop production, which, both in its narrow aspect as a source of national wealth, and in its wider significance as the material basis of rural civilisation, must always remain one of the most important of human activities.

We may take it as an axiom that the developments of the future will in the main grow out of those of the past. There are no breaks in the continuity of progress in agriculture; the farmer's unit of time—the four- or five-year rotation—is too big to allow of sudden jumps and short cuts from one stage to another; and so, if we want to find the most promising lines of progress for the future, we must first discover the lines along which progress has been made in the past.

The rotations and methods now in use are based on those of mediæval times, which in turn go back to a high antiquity. The early system was very simple; the arable land grew corn to provide food and beer for man, while the grass-land, meadows, commons, &c., provided food for beasts. The arable crops were wheat and rye for bread, and barley for beer; peas, oats, beans, and certain mixtures of cereals were also grown for the sake of variety. For our purpose we can group these simply as winter corn, chiefly wheat, rye, and some mixtures—and as spring corn—barley, peas, &c.

Agriculturists speedily discovered—what anyone can find out for himself by simple trial—that it is very difficult to get winter corn to grow on the same land year after year. The crop has to be sown in autumn or early winter if it is to have the best chance of success; the old crop is not removed till August, the land is often too dry to plough in September, and there is not enough time to plough and seed it all in October. So the likeliest chance for sowing the winter corn would be on land on which the preliminary preparations had been made in the summer, so that the final preparations could easily be made in autumn.

On the other hand, spring-sown corn could easily follow winter corn. The land could be left for ploughing at any convenient time in winter; the final operations could be deferred until March without jeopardising the crop.

But, as everyone soon learns to his cost, corn-crops harbour weeds, so that after a couple of years of corn-cropping the land is pretty full of weed-seeds and has to be cleaned.

These troubles could only be met in one way—by growing first winter corn,

then spring corn, and then leaving the land fallow and ploughing it so as to bury the weeds that grew up. Thus, the rotation became,

Winter corn,  
Spring corn,  
Fallow;

and it would be adopted for the best of all possible reasons—because there was no better way. So we find Tusser saying<sup>1</sup> :—

'First rie and then barlie the champion saies  
Or wheat before barlie be champion waies :  
But drink before bread corne with Middlesex men,  
Then lay on more compas, and fallow agen.'

The 'compas' or farmyard manure was obtained from beasts fed on hay drawn from the meadows. There was also some grazing on the stubbles.

Thus there was a transfer of fertility from the grass-land to the arable, which, together with the growth of leguminous weeds on the stubbles, seems to have kept up the fertility of the arable land and allowed of the production of crops that have been estimated at about ten bushels of wheat to the acre.

When improvements first began to be recorded they were made in two directions : in the system of tenure, and in the method of working.

On the usual system of tenure the arable land was divided into strips, which each year were distributed among the villeins and cotters in such manner that each should have his share of good and of poor land. But as each man only had the strip for a year there was no great inducement to make laborious permanent improvements. It was not till the land was enclosed that the cultivator was encouraged to do his best. And so the enclosure of the land—though at the time attended by much trial and tribulation—is now recognised as having been an essential condition to progress. Under these new conditions the yields have been estimated in certain districts at about twenty bushels of wheat, thirty of barley, and forty of oats and pulse.

The second defect of the old system was the lack of food for stock. Nothing beyond a certain amount of hay was provided for the cattle to eat during winter. So long as the grass held out they were well enough off, but from October onwards there was little for them to live upon, and so many were slaughtered and salted.

This lack of winter-keep does not seem to have worried the common people. A dry summer must have given mediæval beasts a bad time, but the country proverbs are in favour of dry summers, probably because they suit the corn best, and corn of some sort formed the chief item in the countryman's diet. Only at killing time, when there was more meat than could be disposed of, would they come in for any great share, and then the village feasts were held, which still survive in many places in an attenuated and modified form.

'At Hallowtide slaughter time entereth in,  
And then doth the husbandman's feasting begin,'

said Tusser.

The first improvements came from Flanders, which has always been a centre of high farming. At a time when history was moving in a different course, and Royalist refugees from England were finding shelter in Flanders, Sir Richard Weston, a Royalist landowner in Surrey, tells us of a conversation he had with a Flemish merchant in 1644 as to the reason why the farmers on the light and apparently poor land between Ghent and Antwerp were accounted the richest in Flanders. 'I will tell you (said hee) the reason, why it yeildeth more profit, is because that Land is naturel to bear Flax, which is called the *Wealth of Flanders* . . . and after the Flax is pulled, it will bear a Crop of *Turneps* . . . after that Crop is off, you may sowe the same Land with *Oats* : and upon them *Clover grass* seed onelie harrowing it with bushes, which will come up after the *Oats* are mowed, and that year yield you a verie great *Pasture* till Christmas; and the next year following you may cut that grass three times, and it will everie time bear such a burden, and so good to feed all sorts of

<sup>1</sup> *Five Hundred Points of Husbandry*, 1573.

Cattel, as the best meadows in the Countrie do not yield the like.' All of which set Sir Richard reflecting 'what an huge *Improvement* I might make of my own Estate, . . . if God Almighty pleased to permit mee quietly to enioie it.'<sup>2</sup>

But Sir Richard was never to carry out his intention, and then, as now, it took a long time to introduce an improvement simply by recommending it. For already the writers on agriculture had begun to spoil matters by putting forth visionary schemes, characterised by more enthusiasm than discernment. In 1580 the first English poultry book appeared,<sup>3</sup> showing, like a multitude of successors, 'how, by the Housebandrie, or rather Housewiferie of Hennes, for five hundred Frankes or Frenche pounds (making Englishe money 55*l.* 11*s.* 1*d.*) once employed, one maie gaine in the yere fower thousande and five hundred Frankes (whiche in Englishe money, maketh five hundreth poundes) of honeste profite: all costes and charges deducted.' In the same spirit Speed wrote later on 'shewing, among many other things, an Aprovement of ground by Rabbits from 200*l.* annual Rent, to 2000*l.* yearly profit, all charges deducted.'<sup>4</sup>

Not till the middle of the eighteenth century was the large-scale test forthcoming. In 1730 Charles, 2nd Viscount Townshend, retired from political life to Raynham, near Fakenham, in Norfolk, to make his famous experiments with turnips and clover, and finally solved the problem of combining animal husbandry with crop-growing—two branches of farming which in the past had often been found mutually antagonistic. Lord Townshend's method was to grow turnips on a large scale, and then allow the animals to eat the crop *in situ*, so that their manure might fertilise the land for the next crop and their treading might consolidate it and so improve it as a seed-bed. After turnips a crop of barley was taken, and after this a crop of grass and clover, part of which could be cut as hay to supply food for the animals during the winter, and the remainder eaten in the field by the animals in order to fertilise the ground for the wheat crop. After wheat, turnips were taken again. The plan was thoroughly sound, and both animals and crops flourished: it survives to this day under the name of the Norfolk rotation, and many progressive farmers still use it with but the small modification that they often grow two corn-crops in succession after the turnips.

But Townshend's improvements were not immediately adopted; certain difficulties also arose which he did not overcome. Turnips are liable to attacks of a minute beetle, *Phyllotreta nemorum*, commonly known as the 'fly,' which in dry weather sometimes almost destroyed the crop and left the animals without food for the winter. Red clover (the ordinary variety grown) will not always grow every fourth year, but sometimes fails after the second or third time. Thus under the combined attacks of turnip-fly and of clover sickness the farmer might find himself with a number of animals on his hands and no food for them, an awkward predicament from which he rarely extricated himself without considerable financial loss.

Fortunately another public-spirited landowner in the same district came forward and continued the experiments: Thomas William Coke, afterwards Earl of Leicester, who inherited in 1776 his uncle's estate at Holkham, about twelve miles north of the scene of Lord Townshend's labours. Although Coke did not surmount these difficulties (no one has entirely done so even yet) he got round them by increasing the range of crops so that he should not be wholly dependent on turnips and clover. Instead of having the whole of his land in four crops he devoted some of it to others, such as sainfoin, winter- and spring-grown tares, mangolds, cocksfoot, potatoes, &c. He purchased oil-cakes for his animals, and thus not only fattened them more rapidly, but also increased the amount of fertilising material in the manure. In this way he imported fertility from other districts to his own, a process which has now become a regular part of British husbandry. Thus sheep and cattle remained the central features of the farm, but the margin of safety was increased by growing other fodder crops

<sup>2</sup> Hartlib, *Husbandry in Flanders*, 1650.

<sup>3</sup> *A Discourse of Housebandrie, no lesse profitable than delectable etc.*, by Prudens Choiselat . . . translated into Englishe by R. E. 1580.

<sup>4</sup> Ad. Speed. *Adam out of Eden*. 1659.

not liable to the same ills as clover and turnips, so that if one set of troubles intervened there would still be a reserve of food for the animals.

These experiments had all been made on light land, but they slowly spread to the heavier soils. It had early been found that some of the new crops could be grown in such a way as to give all the benefits of a bare fallow without the waste. Jethro Tull's drill enabled the seed to be sown in rows; he was not the first to get the idea; Platt had already in 1600 made a wheat dibbler worked by two men 'whereof the one maketh the holes and the other setteth the seed.' Tull, however, was the first to make a machine that actually worked on a farm. And along with the drill he introduced from the vineyards of the south of France the idea of cultivating between the rows. Thus the necessity for bare fallows disappeared, and by the end of the eighteenth century Young considered himself justified in conducting a campaign in his usual vigorous way against them.

The process took a long time to develop, and it is not absolutely complete yet; in 1915 there were still nearly 310,000 acres of bare fallow in England alone. Usually this is on heavy land, where no way has yet been found for dispensing entirely with the bare fallow.

The introduction of clover had the immediate effect of providing more food for the animals by increasing the stock of hay. But soon a new and important effect became manifest. The clover actually benefited the succeeding crops by that wonderful process of nitrogen fixation which took nearly fifty years to discover and is not fully understood even yet.

Thus, by the beginning of the nineteenth century a very much improved system of agriculture was available to farmers. In place of the old mediæval rotation (which some of them were still practising) in which only two-thirds of the arable land was utilised, the remainder being fallow, they now had a rotation enabling them to use all their land, giving them more cattle-food, more farmyard manure, and consequently more human food; further, the clover crop directly enriched the ground.

In consequence the yields went up, and instead of the 10 bushels of wheat of mediæval times, it was not uncommon to get 25 or more bushels; in Hertfordshire, a great corn-raising district, the yields varied from 20 to 40 bushels.<sup>5</sup>

The yields might not have gone much higher, but for a new idea which came in as a result of scientific investigations—an idea which developed till it led to so vast an extension of agriculture and of industry that it may well rank as one of the greatest achievements of science.

Up to 1840 it had always been supposed that crop production must necessarily be limited by the amount of farmyard manure available, and the aim of the agricultural improvers had therefore been to increase the quantity of farmyard manure on the farm.

It had long been known to chemists and physiologists that certain substances were favourable to plant growth, but they were all expensive materials, purchasable only by the ounce, and the observations were regarded as of academic interest only. Thus, Francis Home in 1775 had made pot experiments showing that saltpetre, Epsom salt, and 'vitriolated tartar' (*i.e.* potassium sulphate) all led to increased plant-growth. These and similar observations, though interesting, must have seemed to the pundits of the day about as useless and ill-assorted a collection of material as could well have been got together. All these, however, were straightened out and systematised by Liebig's brilliant generalisation in 1840.

Liebig declared that the need of the plant was not farmyard manure, but the mineral substances contained in its ash. If these were supplied it could dispense with farmyard manure, and draw on the illimitable reserves of nitrogen, carbon dioxide, and oxygen of the air for all the rest of the materials it wanted. A prodigious controversy arose, and although many of the details proved to be wrong, there emerged the general truth, first demonstrated at Rothamsted, that crops can be raised perfectly well without any farmyard manure by supplying the necessary simple nutrients. Chemists speedily found out what these were and the forms in which they were most easily given. The

<sup>5</sup> Arthur Young, *General View of the Agriculture of Hertfordshire*, 1804.

first to be introduced was superphosphate of lime, patented by Lawes in 1843, which had so striking an effect that for years farmers were willing to pay about 7*l.* per ton for it.<sup>6</sup> The list of artificial manures has since been extended; as a result, the farmer has been able to increase his manurial operations very considerably, and to fertilise great areas of arable and of grass land that could not possibly have been treated on the old system. The artificial-fertiliser industry has now assumed enormous dimensions, and satisfactorily enough has, in this country, continued mainly in British hands.

The improvements in cropping thus rendered possible stimulated progress in other directions. Since those days implements have been improved out of all recognition: seeds have been improved, and even that interesting figure the agricultural labourer, while largely unimpressed by our scientific achievements, has also advanced in the external comforts of his life, though not as much as he deserves.

Looking back on the brief sketch I have been able to give you, the three great lines of progress have been:—

1. The introduction, usually from Flanders, of crops that had not previously been grown on British farms.
2. The removal of obstacles which prevented crops from making as full growth as they might.
3. The introduction of new methods for increasing the growth of the plant.

These are the methods that have answered in the past, and as they represent the most promising starting-points for the future we shall therefore discuss their application to different types of soil to see what possibilities they offer of further increases in crop-production. We shall first discuss yields per acre and then yields per farm.

The main obstacles to increased plant-growth lie in the climate and in the soil. Climate apparently cannot be altered; we have to adapt ourselves to it by growing crops and varieties suiting the conditions that happen to obtain. But soil can be altered, and it is possible to do a good deal in the way of changing it to suit the crops that are wanted.

In improving the soil the scientific method has proved to be the safest; this consists in first finding out what has to be done and then discovering the best way of doing it. The two problems are very different, and usually require different men; one of an analytical turn of mind, and the other severely practical.

On light soil the two great obstacles to be overcome are the lack of water and the poverty in plant nutrients. Both arise from the same cause, the lack of colloidal substances, such as clay and humus, which have the power of absorbing and retaining water and plant nutrients. There are two ways of dealing with the problem; one is to get round it by increasing the depth of soil through which the roots can range, and the other is to remedy the defect by adding the necessary colloidal substances—clay, marl, or organic matter. In practice it is not possible to add sufficient to overcome the defect entirely, and therefore both methods have to be used.

Depth of soil is perhaps the most important single test that can be applied to light sands. If the soil is shallow, and is underlain by solid rock, pebbles, or gravel, the case has hitherto been hopeless, excepting where the climate is persistently moist. I know of no instance of successful treatment in tolerably dry regions; the areas are generally left alone. They form picturesque heaths, some are used as rabbit-warrens or golf-courses, some are recommended for afforestation.

If the rock, instead of being solid, is simply a thin layer separating the sand above from a great depth of sand below, then improvement can be effected by removing it. This used to be done by hand labour; good instances are afforded by Cox Heath, Maidstone, once a waste, now good cultivated land. Probably a cheaper way now would be to blow the rock out with dynamite or some of the high explosives that will presumably be available after the war. But the improvement is not entirely permanent: in certain conditions the thin

<sup>6</sup> The early superphosphate contained ammonium salts, so that the difference between the old and the modern prices is not as great as it looks.

layer of rock has a tendency to reform which can only be prevented by occasionally ploughing to greater depths than usual.

Once the light soil is made deeper it can be still further improved. The most permanent improvement is to add clay, or preferably marl; this used to be done in many parts of England, but it now only survives on certain fen or peaty soils. Here the soil is not sand but almost pure organic matter; it is, however, very light. The operation in the fens is simple: the marl (mainly clay, and containing only a few per cents. of calcium carbonate) lies about four or five feet below the surface, and is reached by digging a series of holes across the field; it is then thrown up to surface and spread. Another set of holes is then dug about 18 yards away, and the process is repeated until the whole field is covered. The operation is done about every twenty years; it is admittedly very successful, though I have been unable to obtain precise figures to show the value of the improvement; it would be more extensively carried out but for the circumstance that much of the marl lies below the water-table, and cannot be reached by ordinary means.

More usually the marl does not occur under the sand but at some distance away, so that it has to be carried, and this has killed the process in England. Transit difficulties, however, need not be permanent, and they have a way of disappearing in large-scale operations; this was successfully achieved in the intensively cultivated tract of land known as the Pays de Waes in Belgium. The soil is very light: in places it is even blown about by the wind. But clay lies near; it was brought in tramways, and laid on to a depth of about four inches. The soil then became very productive. Excellent results have also been obtained in Denmark, where perhaps more than anywhere else the work has been put on a sound scientific and economic basis. Usually a district is marled by co-operation between farmers whereby the cost of marl on the land is reduced to about 2 kroner (2s. 3d.) per cubic metre. This has necessitated the construction of light railways from the marl pit to the farm, and the work has been carried out by co-operative associations, often working on a loan from the State, free of interest and repayable in twenty-five years. Another method has been for the Society to buy moveable tracks and tip trucks and to let them out to the farmer.

The more usual method of increasing the absorptive power of light sandy soils is to add organic matter, either by dressings of farmyard manure, by feeding crops to sheep on the land, or by a method that wants much further investigation, ploughing crops or crop residues straight into the soil. But the organic matter disappears at a very rapid rate, so that the process needs repeating in one form or another every second or third year. In few cases only can this be dispensed with: where the soil is deep and lies in a valley or even in a saucer-shaped depression there may be enough seepage from the higher land to ensure regularity in water-supply. More usually the addition of organic matter becomes necessary: in the Norfolk Chamber of Agriculture field experiments on light soils no mixture of artificials proved as effective as farmyard manure.

The addition of organic matter must generally be accompanied by the addition of lime or limestone, otherwise the soil may become 'sour'—a remarkable condition, detrimental to plant-growing, but not yet fully understood by chemists, and therefore more easily detected by the vegetation than by analysis. Few light-land farmers use lime or chalk as regularly as they should for the best results. There are two reasons for this. The first is that all crops do not benefit by lime. The potato-crop in particular, which, as we shall see later, is one of the most valuable crops on light lands, responds neither to lime nor chalk in an ordinary way; indeed, lime is considered to be actually harmful by favouring scab. But although the potato- and even the oat-crop may not benefit by liming, the clover certainly does, and this reacts on the corn-crops that follow. Experiments are much needed to determine at what point in the rotation lime or limestone should be added.

The second reason against liming or chalking is the old one of transit. The problem is solving itself wherever finely ground limestone is to be had, but over considerable tracts of country natural deposits of chalk, especially

<sup>7</sup> A sample analysed in our laboratory contained 1.8 per cent. calcium, 24 per cent. clay, and 31 per cent. fine silt (British units).

if it could be broken, would be cheaper. As already stated, the difficulty has been solved in Denmark by co-operative associations. In Belgium lime used to be carried at half-rate at two periods, spring and autumn, when the railways were less busy than usual.

Further, it is necessary to add all the plant-nutrients, for sand is usually deficient in these, excepting in places calcium phosphate. The common English practice is to import feeding-stuffs to be eaten by sheep on the land, so that the great proportion of the nitrogen, potash, and phosphates thus brought on to the farm shall get straight into the soil. This is not sufficient, however, and artificial manures should be used as well and far more extensively than at present: nitrogen, potash, and phosphates are all wanted.

These additions do not end the matter. Light sandy soils are very prone to weeds, and constant cultivation is necessary to keep them down. Fortunately the cultivation serves another purpose as well; it helps to retain the moisture content of the soil.

Thus the management of a light sandy soil is a constant struggle: it demands constant surface cultivations, frequent additions of fertilisers, of organic matter and lime, and periodical deep ploughings to check any tendency to pan formation. When all this is done the light soils become very productive; they will grow almost any crops, and they can be cultivated easily and at almost but not quite any time. One of their chief defects is that cereal crops do not produce as much grain as might be expected: in the words of the practical man, they will not 'corn out.' This phenomenon requires further investigation.

On the other hand, neglect in any of these directions soon leads to failure. For light soils more than any others, *facilis descensus Averni*: an idle or incompetent man may in a few seasons let down a farm that has been patiently built up by his industrious predecessors. It is easy to find tragic instances of this; and, if any colonisation scheme is attempted on a large scale, it is to be hoped that steps will be taken to prevent falling back.

These are the conditions for the successful management of light soils: how far can they be attained? This is a purely economic question. It is obvious that success is only possible if the gross returns are sufficient to cover the costs. Now, a very great deal of experience has shown that the ordinary farm-crops—wheat, barley, swedes, &c.—do not bring in sufficient gross return to encourage good farming. Numerous instances occur on the tracts of light Bagshot sands running westwards from Woking and Staines to beyond Aldershot and Wokingham. Some of the old four-course farms still survive—wretched little affairs, the tenants of which are constantly struggling against chronic poverty. Again, considerable areas of light land in Hertfordshire caused their cultivators to go bankrupt in the 'nineties when only these ordinary crops were grown. The old Townshend and Coke method of feeding sheep on the land is satisfactory, but it requires the triple, and not very common, qualifications of capital, good knowledge of sheep and of crop management. The situation in Hertfordshire was saved by the potato-crop which, on these farms, brings in a gross return of 25*l.* or more per acre against a return of 7*l.* from wheat at pre-war prices. Of course the expenditure on potatoes is much greater than on wheat, but that does not matter; the point is that the expenditure has to be incurred in any case if the land is to be kept in good cultivation, and potatoes bring in the necessary return, while wheat does not. Potatoes are the commonest of money-finding crops, but they are not the only ones. Greens are in some places very successful, bringing in 17*l.* or more gross return. In North Kent various market-garden crops are used. In parts of Norfolk blue peas have answered satisfactorily. Clover-seed is a useful adjunct in places, but it is not sufficiently reliable for the chief money-maker. One finds in Suffolk, for example, areas of light land where farmers depend on a lucky haul in clover seed, and consequently are unable to do their sheep and their land as well as they should. Sugar-beet would also serve the purpose; so would potatoes grown to provide starch. The same end is achieved if two or more crops can be raised in a single season, as in some of the schemes suggested by Wibberley. There is great scope here for the ingenious-minded agriculturist.

It is not necessary to take the money-finding crop very often; once in four years may prove sufficient. But the system is capable of considerable intensifica-



tion if the farmer has sufficient capital, or if his holding is so small that his capital can be more intensively used. It is possible to grow nothing but crops bringing in a large gross return; in districts round Sandy, Biggleswade, &c., the market-garden crops have been exclusively grown for very many years with great success<sup>8</sup>; this method also proves very successful on the Bagshot sands. It is not clear, however, that this type of farming could be indefinitely extended.

The best hope for improvement of these light soils lies in increasing the number of money-finding crops, improving the methods of growing them—e.g., the introduction of the boxing and spraying of potatoes—and their relation to the other crops or the live-stock, and improving the organisation for disposing of them, so that farmers will feel justified in spending the rather considerable sums of money without which light soils cannot be successfully managed.

We can now leave these light soils and pass to the opposite extreme—the heavy clay soils. These suffer from the fundamental defect that the clay easily deflocculates and assumes a sticky, pasty condition when wet, and a hard, lumpy condition when dry. In spite of a good deal of laboratory work, deflocculation is not well understood; it is known, however, to be a special case of a very general phenomenon—flocculation of suspended colloids—and it will presumably succumb to treatment when the general problem is solved. Important advances have been made in the last few years by Perrin,<sup>9</sup> and it would be interesting to apply his methods to clay.

For the time being the only feasible method of flocculating clay is to add lime or chalk, but experience shows that liming and chalking must be accompanied by drainage to be a complete success. Any attempt to improve crop production on heavy lands involves these as the first steps.

Liming and chalking present no serious difficulties beyond those of transit already discussed; but drainage does.

The old drains laid down in the great reclamation schemes of the '60s, and still often called the Government drains, are in many places blocked up, and new ones are wanted. The old system is too costly for modern use, but fortunately mole drainage promises to be an efficient and much cheaper substitute. Already one or two large companies are at work in Oxfordshire and the surrounding counties ploughing either by the acre or the chain, and already good results have been obtained in Oxfordshire, Essex, and elsewhere. But if drainage is to be a complete success there must be co-ordination and a certain amount of control over the whole drainage area. This control already exists in some places: the Fens, Romney Marsh, &c., and it can be worked satisfactorily. But in the great clay areas there is no unified control, and it is left to each individual to act or refrain from acting just as he pleases. One man may drain his land, but if his neighbour a little lower down does not choose to keep the ditch clean there may be endless trouble. Further, if his successor chooses to neglect the drains, they may get blocked up, and much of the capital sunk in them may be wasted. It is obviously undesirable that a great fundamental improvement should thus be at the mercy of individuals, and the whole matter requires careful considered action.

Where clay soils are drained and limed it is possible to begin to do something with them. Wheat, beans, mangolds, cabbages, and grass can all be produced. There is often a tendency to shallow ploughing resulting in the formation of a rather solid plough-sole a few inches below the surface. Marked improvement has resulted on some of the Essex land by breaking this up with a subsoiler every four or five years; the practice, unfortunately, is not common, and demonstration plots on heavy soils in different parts of the country are much needed to extend it.

But, when all is said and done, clays still suffer from two disadvantages: they are only suited to a limited number of crops, and they are difficult to cultivate. The land may be too hard in autumn to be ploughed for winter

<sup>8</sup> In 1808 they were said to have been grown from time immemorial.—Batchelor, *General View of the Agriculture of Bedford*.

<sup>9</sup> *Brownian Movement and Molecular Reality*. Perrin (London, Taylor & Francis, 1910).

corn; too wet in winter to be ploughed for spring corn; and too dry in spring to be prepared for mangolds. There are times in between when something can be done, but only the man who is skilful enough to take full advantage of these intervals has much hope of success. Most men, therefore, prefer not to run the risk of cultivation, and lay the land down to permanent grass.

There are two directions in which the risk can be reduced, though it will still remain a serious factor.

The great difficulty of cultivation arises largely from the circumstance that only on a relatively small number of days are both soil and weather suitable for ploughing. The result is that much of the work is left till late, and late work tends to be bad work. This can only be overcome by speeding up the process of ploughing during the favourable opportunities, and so far as I can see this is only possible by the use of motors. I believe, therefore, that motor-ploughs and cultivating implements will play a considerable part in the improvement of heavy land.

A second direction in which the risk can be reduced is by keeping up the supply of organic matter in the soil. The action of organic matter is partly mechanical, partly more complex, but the result is that the soil becomes lighter, works down more readily to a tilth, and shows less tendency to fluctuations in crop. The Broadbalk plot at Rothamsted, receiving farmyard manure, gives a steadier yield, showing far less fluctuation than the plots receiving dressings of artificial manures.

Probably the cheapest and most satisfactory way of increasing the supply of organic matter in the soil is by ploughing in crop residues, such as, for example, are left by a seeds mixture, a clover ley, or ploughed-up grass-land. Their effect is well seen by comparing the wheat-yields on the Agdell field at Rothamsted, where clover is ploughed in prior to the wheat, with those on Broadbalk, where wheat only is grown, and where, therefore, nothing bigger than wheat stubble and its accompanying weeds is ever ploughed in. The Broadbalk plot receives far more manure than the Agdell plot, and in good years it gives higher yields, but in poor years it comes down much lower; the fluctuations are considerably greater.

*Steadying Effect of Crop Residues on Yield of Wheat.*

	Agdell Field. After Clover ploughed in. Complete Artificial	Broadbalk. After previous Wheat. Complete Artificial
Average of all . . . . .	35 bushels	30 bushels
Highest yield, 1863 . . . . .	46 "	56 "
Low yields, 1871 . . . . .	25 "	13½ "
" " 1875 . . . . .	31 "	11 "
" " 1879 . . . . .	13 "	5 "
" " 1903 . . . . .	28 "	24 "

Land that went down to grass in the '90s because cultivation was too risky has now gained so much organic matter that it can safely be cultivated again. Mr. Strutt has done this satisfactorily on some of the heavy Essex clays. The Duke of Marlborough has ploughed up some of the grass in Blenheim Park, though here, as a matter of fact, the land is not all clay but includes corn-brash that never need have gone down to grass at all. At Rothamsted we have recently ploughed up a poor grass field that for some years had barely paid its rent, and the crops promise to be considerably more remunerative than anything we have had before. The conditions for success seem to be that the soil shall be turned right over in the ploughing, and then rolled down so as to prevent the grass from growing up between the furrows; and, further, that measures should at once be taken against weeds, either by growing hoed crops like potatoes or beans drilled in rows sufficiently far apart, or some dense crop like winter oats that will smother everything else. In our ploughed-up field wherever the trial crops are thin we had a brilliant display of charlock and

poppies, neither of which were prevalent in the adjoining arable fields; the causes of this are under investigation.

Thus, the movement in favour of ploughing up some of our grass land is eminently sound. But sooner or later the organic matter now stored in the soil will be much reduced, and trouble may then be anticipated. The difficulty ought not to be insuperable; the way out seems to be the North Country system of alternate grass and tillage; leaving the land in arable cultivation for four or five years, and then in grass for four or five years. I think that a few demonstrations started on these lines in heavy-land districts would resolve many of the farmers' doubts as to the advisability of breaking up some of their grass-land. Some grass, however, there will always be on the clays, and the great need is to improve it. Methods have been worked out in several places, and they should now be more generally applied. In most cases basic slag is sufficient to begin with, and it produces an improved herbage which may well repay further treatment.

We now turn to the loams. These present no special difficulties to be overcome, but their productiveness is, of course, subject to all the usual factors influencing plant-growth, viz., sufficient supply of water, air and plant nutrients, proper temperature, root-room, and absence of injurious factors. Water-supply, air-supply, and temperature do not usually cause much trouble, but the crop may be hampered by lack of root-room, in which case periodical deep ploughing or subsoiling may bring about a substantial improvement. It is not necessary always to plough deeply; the point is to vary the depth, and once in about four years to go deeply, so as to stir up the subsoil. On our land we have done this for potatoes, and we found that subsoiling at a cost of about 3s. per acre was followed by an increase of 10 cwt., worth 35s., in the yield per acre. One of our neighbours does much more, and once in every five years ploughs 17 inches deep with a steam plough; this is done in July, and the results appear to be satisfactory.

Once these great fundamental things have received attention, all these soils—loams, sands, and clays—can be further improved by proper treatment with fertilisers. A great deal of good work has been done on this subject, and the results are steadily being diffused among farmers.

When the results of field experiments are plotted they fall into two groups:—

1. An increase in the fertiliser causes an increase in crop production, but beyond a certain stage the increase falls off. This is especially the case with nitrogenous fertilisers.

The Rothamsted experiments with wheat give the following results:—

—	Grain	Increase per 200 lb. Ammo- nium Salts	Straw	Increase per 200 lb. Ammo- nium Salts
	Bushels	Bushels	Cwt.	Cwt.
Mineral manure alone .	14.5	—	12.1	—
Mineral manure + 200 lbs. Ammonium salts . . .	23.2	8.7	21.4	9.3
Mineral manure + 400 lbs. Ammonium salts . . .	32.1	8.9	32.9	11.5
Mineral manure + 600 lbs. Ammonium salts . . .	36.6	4.5	41.1	8.2

In the Irish experiments carried out on a uniform scheme at a large number of centres, when the quantity of sulphate of ammonia was varied, the yields of potatoes were:—

Standard Manure of Potash and Phosphates +		
1 cwt. Sulphate of Ammonia.	1½ cwt. Sulphate of Ammonia	2 cwt. Sulphate of Ammonia
Tons Cwt.	Tons Cwt.	Tons Cwt.
11 2	11 6	11 11

Phosphatic fertilisers show the same kind of effect, but less frequently. In the Aberdeen experiments increases in the dressing of superphosphate up to the extraordinary dressing of 10 cwt. per acre still gave increases in the turnip crops, while in the Cambridge experiments on the fen soils increases in superphosphate up to 6 and 8 cwt. gave marked increases in mangolds and potatoes.

2. But, when for any reason such as climate, supply of other nutrients, or some soil condition, the crop has reached its limit of growth, then the extra fertiliser has no effect; not until the limiting factor is removed can it begin to act. In our own experiments swedes did not respond to increased dressings of manure, because the climate does not allow of more growth than about 12 tons to the acre; so that, unlike the Aberdeen results, the extra dressings of manure were without effect. In the Irish experiments already quoted, increasing dressings of superphosphate had no effect on the yield of potatoes so long as only 1 cwt. of sulphate of ammonia was given.

Standard Dressing of Nitrogen and Potash +			
3 cwt. of super		4 cwt. of super	5 cwt. of super
Tons Cwt.		Tons Cwt.	Tons Cwt.
10	16	11 2	11 3

Whitney considers that this is the general rule in the United States, and, in summarising the results of several thousand fertiliser experiments on wheat, cotton, and potatoes, finds little indication of any significant difference in productivity due to different amounts of fertiliser used.<sup>10</sup>

There is no real discrepancy between the two cases. What happens in the first is that there is more tillering of the cereals, so that the number of individual leaves and stems keeps on increasing, as the dressings of fertiliser increase. The effect of phosphates on the root-crops is probably to facilitate swelling of the roots, or, in the case of potatoes, to increase the number of tubers, either of which would probably facilitate the deposition of storage products from the sap. In these experiments there is no indication of any end-point, and apparently the more the crop is fed the larger would be the yield. But the process does come to an end. The final limit is reached by the inability of the plant to stand up any longer or to grow any bigger. When the corn-crop gets beyond a certain size it is almost invariably beaten down by the wind and rain, so that the difficulty of getting it in becomes considerable. Heavy dressings of nitrogenous manures also predispose the crop to fungoid disease; attacks apparently being facilitated by the thinning of the cell-walls and the change in composition of the cell-sap.

The way for further progress is then to seek new varieties that can stand up and resist disease. And here a good deal has been done. Biffen has shown how desirable properties may be transferred from one wheat to another, and his investigations are revealing the limits within which it is possible to construct a variety of wheat according to the growers' specification. Similar work is badly wanted for other crops. Fortunately our great seedsmen are fully alive to the possibilities in this direction, and have already done much useful work. It is not only in the case of cereals and potatoes that new varieties can be sought; there is great scope also for new varieties of all other crops. The striking superiority of wild white clover over the ordinary cultivated varieties, and the great differences demonstrated at Woburn between varieties of rape and lucerne, show that there is a considerable future for this sort of work. It need not stop with varieties of crops at present in cultivation: the net might be thrown further afield. Elliot boldly introduced some unconventional constituents into his mixture with considerable success. Swiss pastures look strange mixtures to English agriculturists, accustomed to recognise only grasses and clovers as pasture crops, and yet the Swiss agriculturists assure us of the value of some of the other plants. When I see a light-land farmer spending time and money in trying to make a fodder-crop grow, and time and money

<sup>10</sup> U.S. Dept. of Agric., Bureau of Soils, Bull. 62, 65, 66.

in trying to prevent ragwort from growing, I cannot help thinking how much the problem would be simplified if a plant-breeder would evolve a ragwort with the vigour of the weed and the value of the fodder crop. The great value of new varieties is the diversity that can thus be introduced. Only rarely does a crop find precisely suitable conditions, and only rarely can the conditions be altered to suit the crop entirely. There is always a gap between what the crop wants and what it can get. It is the realisation of this fact that makes the farmer a chronic grumbler.

Now, this gap can be bridged to some extent from both ends. The soil conditions can be changed somewhat by the methods already discussed, and the plant requirements can be varied by altering its construction. It is on these lines that new varieties ought to be studied. When a variety is fixed by the breeder the proper course is to find the conditions to which it is specially suited. This, I think, is much better than trying to put the varieties in a definite order of merit by making a number of tests over the whole county, and then averaging the lot. To begin with, the results of one season rarely agree with those of another over any large area, and in three successive years three different varieties may turn out to be the best—a result which is easily intelligible when put this way, though it looks very odd when set out baldly in a seedsman's catalogue without reference to the fact that the results were obtained in different seasons. Even when an average can be obtained it is not entirely useful. Averages want interpreting for the ordinary farmer, for average conditions never seem to arise on any particular farm.

It would be a useful thing to multiply simple combined variety and manurial tests, such as are being made by Mr. Dudding on Lord De Saumarez's estate, where varieties run in one direction and a few selected manurial dressings run in the other.

There seems considerable prospect of increased production by securing better co-ordination between the soil conditions and the variety used, and I am very hopeful of advances in this direction.

The question arises: How far can the plant-breeder go? Is there any prospect of putting something into the plant that is not there already, or can he only transfer a property from one variety to another? Can the physiologist make the plant do more than its normal growth, or do anything beyond ensuring that it shall have the conditions it wants?

These questions are difficult to discuss: nothing but the *fait accompli* being really satisfactory. I shall not deal with the breeding work, but may refer to some of the physiological attempts to stimulate or in some similar way increase plant growth. Many have been made, but so far there is no indication of success. Laboratory evidence is periodically adduced to show that certain substances or electrical or other treatments stimulate plant growth. One of the earliest was manganese sulphate: then came other substances, and in due course radium. All these were tried in crop production, and all failed. Manganese salts were tested by Dr. Winifred Brenchley and by Dr. Voelcker; radium by Mr. Martin H. Sutton. At the present time auximones are under investigation.

All these things are, of course, perfectly legitimate objects of investigation in the laboratory and experiment station. Some of them may succeed: Miss Dudgeon's experiments at Dumfries show that the last word has not yet been said about the effect of the electrical discharge on plants; in any case no man can set limits to the achievements of science: the impossible of yesterday has often become the commonplace of to-day. Unfortunately the investigators have sometimes let their enthusiasm outrun their discretion, and instead of waiting for properly conducted field trials they have rushed the laboratory results out to the public, sometimes accompanying the account with picturesque multiplication sums showing what would happen if the flower-pot were multiplied up to an acre, and the acre multiplied up to a million acres.

If this were done by a business house to push a proprietary article we might safely leave the matter to economic forces and the County Council experts, but the sad thing is that it has been done in the name of Science: tests of the roughest description have been circulated as if they had satisfied the canons of scientific criticism, and the farmer is left under the impression that the

method is on a sound basis and is going to increase very considerably the crop-production of the country.

Now, this is distinctly unfortunate. During the last twenty years the farmers' appreciation of science has been steadily rising, and the most cordial relationships exist between the men of science at the Agricultural Colleges and Research Institutions and the best farmers and agricultural journalists. Promises made in the name of Science are taken seriously and remembered, and if they are not fulfilled Science will be blamed. Those of us who are trying to apply Science to Agriculture are placed in the very awkward position of either having to disclaim a piece of work that may finally turn out very useful, or else appearing to acquiesce in a promise—real or implied—that will never be kept.

The position we have reached is that crop-production may be increased :—

1. On light soils by more extended cultivation of crops that bring in a high return per acre, and therefore provide the money for the constant cultivations and manurings necessary on this class of land. This would involve improvements in the machinery for distribution of the produce.
2. On heavy land by chalking or liming, followed by drainage. To obtain the best results a better system of control of main drains and ditches is needed. Cultivation of this land is always risky, but the risk can be reduced :—
  - (a) By quicker ploughing in autumn so as to bring the work well forward : this seems only possible by the use of the motor-plough.
  - (b) By keeping up the supplies of organic matter in the soil ; the simplest plan seems to be the adoption of the North Country system, in which the land is alternately in grass and in tillage. There still remains a risk which on present conditions the farmer may not feel able to take.
3. On all soils increased yields may be obtained by increasing the supply of fertilisers.
4. Finally, however, there comes a point where further increases in fertiliser dressings cease to be effective : the plant either cannot grow any bigger, or it cannot stand up any longer.
5. Further crop increases can only be obtained by finding new varieties that can grow bigger or stand up better. Considerable improvements may be anticipated by a closer co-ordination of crop variety and soil and climatic conditions.

But there is another way in which Science can further the problems of crop-production. Instead of aiming solely at increased yields per acre, attempts may be made to reduce the cost per acre and increase the certainty of production.

One of the most hopeful ways of attacking this problem is to increase the efficiency of the manurial treatment. No manurial scheme is perfect ; no farmer ever recovers in his crop the whole of the fertilising constituents applied to the soil ; there is always a loss. In our Broadbalk experiments, where wheat is grown year after year on the same land and large dressings of artificials are used, we do not recover in the crop more than about 30 to 40 per cent. of the added nitrogen.

Now, whilst we can never hope for perfect efficiency, *i.e.* for 100 per cent. recovery, we can hope to do better than this. On our own fields we improve considerably on it every year by the adoption of a proper rotation. Thus, whereas we apply 400 lb. of ammonium salts every year in addition to potash and phosphate on the continuous wheat-plots, and only get 32 bushels of wheat in return, we get the same yield on the rotation-plots without any addition of ammonium salts and even without clover : when clover is introduced we get an even higher yield. There are several causes at work which I need not now discuss. The broad conclusion is that the efficiency of a manurial scheme can be enhanced by arranging a proper rotation, with the practical result that the same yields can be got at less expenditure on manure.

Further experiments on the relationship between the efficiency of fertiliser action and the rotation are very desirable. Rotation experiments have a way of

becoming involved unless one keeps them rigidly to one point: but there should be no difficulty in working out a relatively simple scheme for any one locality.

Intimately bound up with all this is the more economical use of fertilisers generally—not the more restricted use, but the more effective use. To a considerable extent the question is one of nitrogen. Nitrates wash out of the soil so readily that it is never safe to assume that any will survive the winter, so that anything left untouched by the standing crop may easily be lost. The Broadbalk results show that more nitrogen is taken up by the crop, and therefore the fertiliser is more economically used when potash and phosphates are present in sufficient quantities than when either is lacking. The efficiency of the nitrate is therefore increased by properly balancing the manure.

Attempts to calculate the best-balanced fertiliser have all failed. Chemists have long since given up the idea that the composition of the crop afforded any clue to its fertiliser requirements, although this idea still persists in places. Nothing but actual trials can show what the crop needs. A great many trials have been made in the counties during the last twenty years which have added considerably to our knowledge of the action of fertilisers. Unfortunately much of the work lies buried in County Council Reports and Bulletins, some of which seem to have disappeared almost entirely—at any rate we have not succeeded in getting them at Rothamsted, in spite of great efforts to do so. I have recently been through many of these Reports, and have been struck with the value of much of the work. Its main disadvantage is that no uniform scheme was applied all over the country: each county made its own scheme, or did without one if it preferred. It was assumed that soil and climate must profoundly affect the action of fertilisers, and consequently that uniformity would be unnecessary. In Ireland, on the other hand, one and the same scheme was adopted everywhere, and the results are of considerable value.

I hope that our own county authorities will be able to agree on a uniform scheme after the War: this would simplify very considerably the experimental work on the economical use of fertilisers.

Some of these old experiments served the useful purpose of showing that better returns were got from dung combined with artificials than from dung alone, and the theme, though somewhat hackneyed, is by no means exhausted. Thus, in an experiment by the Leeds University Agricultural Department, 20 tons of dung supplemented by artificials gave larger returns than 38 tons of dung without artificials. In the Irish experiments carried out over the eleven years 1901-1911 at 353 centres, additions of superphosphate and of potash to dressings of dung considerably increased the yield, and, of course, the utilisation of nitrogen:—

	Tons Cwt.
No manure . . . . .	4 0
15 tons farmyard manure per acre . . . . .	8 4
20 tons farmyard manure per acre . . . . .	9 2
15 tons farmyard manure per acre + 1 cwt. sulphate of ammonia . . . . .	9 3
15 tons farmyard manure per acre + 1 cwt. sulphate of ammonia + 4 cwt. superphosphate . . . . .	9 19
15 tons farmyard manure per acre + 1 cwt. sulphate of ammonia + 4 cwt. superphosphate + 1 cwt. muriate of potash . . . . .	10 17

More experiments of this sort are wanted. Generally the experiments have been reported for single crops only. But the farmer works on a different basis; his unit is the rotation, and therefore the effect should be shown over the rotation.

Again, it is known in a general way (though there are remarkably few published experiments on the point, and there ought to be more) that phosphates increase the feeding value of crops, and therefore that a crop intended to be fed to live stock will be improved by dressings of phosphate, even if no increased growth is obtained. In many cases the crops are fed on the land to sheep frankly with the idea of benefiting subsequent crops. What is the effect of the phosphate here? How are the subsequent crops affected by improving the feeding value to the folded crop?

Again, potash and phosphates are known to benefit the clover crop, and

clover residues to benefit succeeding crops. How would a dressing of potash and phosphates to the clover react on the next crops? Practically no farmer gives it; would it not be worth while? These and similar questions can only be answered by actual experiments, and in view of the importance of making the best use of our manures over the whole rotation, it is desirable that they should be put in hand.

Another direction in which great economy is possible is in the management of farmyard manure. It has been a common complaint against agricultural investigators that they have concerned themselves exclusively with artificials, and left untouched the greater problem of the manure-heap. For farmyard manure is the staple manure of the countryside; no direct estimate of the amount used annually appears to be available, but the statistics show that  $9\frac{1}{2}$  million tons of straw, wheat, barley, and oats, are grown in the country. If we assume that all this is made into manure, and that one ton of straw gives on an average four tons of manure, we arrive at 37 million tons of farmyard manure made per annum. The value at 5s. per ton is 9,250,000l.; all the artificial manures consumed in Great Britain probably do not much exceed 6,500,000l. in value each year.

Through the generosity of the Hon. Rupert Guinness, we have been able at Rothamsted to attack this important subject, and Mr. Richards has obtained some striking results, showing what losses may take place and indicating methods of avoiding them. The great sources of loss are the air and the weather. Heaps made up in the orthodox manner—compacted but left out in the field without shelter—lost in three months 39 per cent. of their dry matter and 87 per cent. of their original ammoniacal nitrogen. When the heap was stored under cover the loss was smaller, being 30 per cent. of the dry matter and 55 per cent. of the ammoniacal nitrogen, so that the provision of shelter added materially to the value of the manure. These analytical results were confirmed by field trials. Ten tons of the sheltered manure gave nine tons of potatoes per acre, against 7.4 tons given by ten tons of the exposed manure. Reckoning the potatoes as worth 70s. per ton, the extra crop obtained by sheltering the manure is worth 5l. 12s. per acre, without taking into account the fact that less dung is required to make ten tons of sheltered manure.

But there is still a loss even from the sheltered heaps, amounting in our various experiments to some 50 per cent. of the ammoniacal nitrogen, and some 30 per cent. of the total. Below this we see no way of going at present so long as the manure is stored in heaps. Laboratory experiments, however, indicate a much better method of storage.

If the manure is kept entirely out of contact of air it can be preserved absolutely without loss; and if, further, it is warm enough (about 26° C.) it will even improve by the ammoniacal fermentation which sets in. No heap we have seen in practice reaches this happy condition, and we have no indication that any heap ever could. The only perfect storage would appear to be in pits or tanks that could be closed absolutely air-tight. Whether this could be done in practice is a matter that can only be settled by experiments. These we hope to put in hand next season, and in the first instance we are starting with liquid manure, the storage of which, especially on dairy farms, is admittedly a weak point in farm management.

Another direction in which saving is possible is in the soil itself. It is now 46 years since Lawes and Gilbert built those remarkable drain gauges at Rothamsted which for the first time enabled chemists to determine precisely the quantity of fertilising material washed out from the soil by rain. When there was no crop on the ground the soil lost by drainage about 40 lb. of nitrogen in the form of valuable nitrates, a quantity as great as is contained in a 24 lb. bushel crop of wheat. This was soil without manure. More recently the subject has been investigated in another way. The amount of nitrate in certain plots has been determined at ten days' intervals for a period of two years. In the early part of the year the nitrate is low in amount; it rises rapidly in spring or early summer—the rise coinciding with the rise in soil temperature. During summer there is considerable increase in fallow land, but not in cropped land—partly because the crop is taking up



nitrate, and partly also apparently because the growing crop seems to interfere with bacterial activity. But in autumn, when the crop is off, there is a great rise in nitrate production, which becomes particularly marked if the land is broken up immediately and given a late fallow. Finally, in early winter the soil is left with a large amount of nitrate. If the soil lies bare through the winter the nitrate is lost; last winter the December and February rains were specially disastrous, so that when spring came in we were left on some of our plots with only 40 lb. of nitrogen as nitrate out of an autumn stock of 70 to 100 lb.—having lost no less than 30 lb., and on some of the plots considerably more, during the winter.

Unfortunately the heaviest loss falls on the best manured land, and the crops that suffer most are those like wheat or oats, that are grown on the residues of the previous year's dressings. Some years ago Sir Napier Shaw startled agriculturists by stating that every inch of rain falling during the months of September, October, and November caused a falling-off of two bushels of wheat per acre from an ideal standard of 46 bushels per acre over the whole of the Eastern Counties. There can be no doubt that the washing out of nitrates is an important factor in this fall, and it is no exaggeration to say that our losses from this cause are enormous. All this, of course, emphasises the need of spring dressings of quick-acting nitrogenous manures, and accounts for the marked improvements that set in on many soils when spring dressings are given.

A good way of getting round this difficulty is to sow a catch-crop in autumn, and either to plough it in before the main crop is sown or to feed it to stock, whichever is the more convenient. The practice is an old one, but, apart from the usual case of sowing clover in the growing corn, it is not very common; there are several practical difficulties, chiefly arising from the dryness of the ground at harvest time. This can be met by shallow cultivations immediately the corn is cut, and without waiting for it to be carried. The problem is under investigation. At Rothamsted we find mustard answers very well; it grows more easily than most other things do in September, and it has a great capacity for taking up nitrates. *Trifolium* is also valuable where it will stand the winter. It likes a firm seed bed, so that it only wants harrowing in to the stubbles, and it not only takes up nitrate, but it can fix nitrogen as well, though we do not know how far it actually does so under these conditions. In Belgium carrots and turnips are both grown as catch-crops. Carrot seed is broadcasted in winter wheat just before the ears begin to form, and, although it can neither be rolled nor harrowed in, it has no difficulty in germinating; by the time the wheat is cut the plant is already established, and it is about  $2\frac{1}{2}$  to 3 inches high. It is still weak, but after a harrowing to tear out weeds, and, if necessary, a dressing of liquid manure, it begins to grow more vigorously, and finally yields a valuable crop. Turnips are sown after harvest. The corn stooks are set in rows so as to leave fairly wide strips of the field, which are at once lightly ploughed; the seed is then sown, and the land harrowed down and rolled. The strips on which the stooks were placed are similarly sown at the earliest opportunity. It is essential, however, that the ploughing and harrowing should be done immediately after cutting, as otherwise soil moisture is lost, and germination may not take place. A dressing of phosphate is usually given.

It thus appears that the wastage of nitrates in winter can be greatly reduced, but the process requires suitable crops and rapid cultivation methods. Neither of these ought to be beyond the power of the agriculturist to provide. The possibilities are many. Wibberley has discussed several schemes of continuous cropping that satisfy these requirements, giving a succession of crops which cover the land at the critical time when losses would occur. And our implement makers are steadily increasing the number and effectiveness of the implements, while motor traction promises also to increase the speed of working.

Our experiments indicate two difficulties, which, however, ought not to be beyond control:—

1. This close succession of crops reduces the opportunities of fallowing and cleaning the land. A fallow seems to have an effect on the soil nothing else can quite produce. Thus in the season of 1913 the yields on the Hoosfield barley

plots, which had been fallowed during 1912, were higher than they had been for nearly sixty years—since 1854 and 1857: several of the plots yielded over 60 bushels of grain, 30 cwt. of straw, and 7,000 lb. of total produce per acre. Part of this result was due to the season, which was very favourable to barley—the spring being moist, and the summer damp and cool. But a considerable part must be attributed to the fallow, for on the Agdell rotation-field, where there had been no fallow in the preceding year, the yields were by no means extraordinary, the highest crop being 33 bushels of grain, 15 cwt. of straw, and 3,500 lb. of total produce—results which are frequently obtainable on the same plots. The fields are not contiguous, and comparisons must not be pushed too far; nevertheless, where the conditions were comparable the yields were not dissimilar: the unmanured plot in Agdell field (which had virtually been fallowed during the preceding year, the turnip crop having failed) gave 18·5 bushels of grain and 8 cwt. of straw, nearly the same as the unmanured Hoosfield plot, 21 bushels of grain and 10 cwt. of straw. Only where the turnip crop on Agdell had succeeded in 1912 were the barley yields markedly less than on Hoosfield. But so far as our experiments go these effects can all be obtained with late summer or autumn fallows. On a farm near to our own it is found worth while in a dry year to break up the seeds ley immediately after the first cut so as to get some summer cultivation done, and give a bastard fallow before putting in the winter corn.

On a well managed farm on the Brick Earth of the Sussex coast the corn is got in July: the steam tackle is put on to break up the land at once, and a fallow is given during August and September. If these months are fairly dry, as is usually the case, the loss of nitrate is not great and the cultivations kill weeds. If, in addition, the weather is hot, the soil benefits further. Hot-weather cultivation improves nearly all soils, probably because it has some partial sterilising action: the only soils that do not benefit so far as I know are the fen soils, and I do not quite understand why this should be. Thus the possibility of co-ordinating the cropping with the biochemical activities in the soil promises considerable saving of valuable soil materials.

2. The more serious difficulty is the pests, of which the number seems amazing. The more intensive the cropping the greater the opportunity for the various pests to live, till finally in the glass-house nursery industry the trouble becomes acute. At present our methods of dealing with them are not very discriminating, and in practice we only attempt to control two in the open field—finger-and-toe by liming, and potato disease by spraying, while two or three—wireworm and turnip-flea—are more or less kept in check by the adoption of special cultivation or other devices. All the rest are simply suffered. This year, for instance, our corn was attacked in various places by wireworm, by turnip-flea, by rats and by rust, by smut, frit-fly and aphid, to say nothing of birds, rabbits, game, against many of which the farmer is at present powerless.

In glass-houses it is possible to adopt the heroic method of sterilising the soil and killing everything, but this is not yet practicable on the farm, and even if it were it does not prevent re-population. Further, most pests have their parasites, and wholesale sterilisation may help the pest by destroying the parasites. Imms has recently noted two cases where this is said to have happened: scale insects, which are helped by spraying the parasitised insects; and a wheat-pest (*Diplosis tritici*, a Cecidomyiid) which was helped rather than hindered by burning the cavings from affected wheat, because the pupæ thus destroyed were parasitised, while those remaining in the soil were not.

Nothing much can be done to deal with soil-pests until we know more about them, and it is to obtain this knowledge that recent work is being done.

When intensive cultivation is carried to an extreme it is followed by a falling off of bacterial efficiency, finally leading to 'sickness' in soil, which has been investigated in some detail in our laboratory.

But the waste of nitrates is not the only nitrogen loss taking place in the soil. On certain of our plots a nitrogen balance-sheet is set up: an analysis of the soil is made every twenty years, account is taken of the nitrogen put in as manure and taken out again by the crop, and a statement can then be drawn up showing the income, the known outgoings, and the residue left in the soil. Three distinct cases are found. On the poor unmanured soil a balance is obtained, the nitrogen removed in the crop being about equal to that supplied

by rain, &c., and lost from the soil. On land laid down to grass no balance is obtained: there is an excess of soil nitrogen, which at first could not be explained, but was finally attributed to the activities of nitrogen-fixing organisms living either in the free state, or in association with the various leguminous crops. Nor is a balance obtained on arable soils heavily dressed with farmyard manure, but here there is a deficit, the nitrogen in the crop being considerably less than that given up by the manure and the soil. Some of the deficit undoubtedly arises from the loss of nitrates already discussed; but there is evidence of a further loss, which is attributed to the evolution of gaseous nitrogen. It is impossible at present to draw a sharp line of demarcation between these two processes in the field, and the investigation is therefore being made in the laboratory. In the meantime the trouble may, however, be met in two ways:

1. The land may be left in grass for a few years so that the gain in nitrogen during this period may balance the loss during the arable period. This is already done in several rotations, but it suffers from the disadvantage that the land during its recuperative grass period is producing less than during the arable period.

2. The land may be kept in arable cultivation, but the loss diminished by increasing the efficiency of the manurial scheme, a problem that has already been discussed.

It is obvious that a knowledge of the times and ways of leakage of nitrogen from the soil puts us in possession of means of reducing the wastage. Field data of the kind required take a long time to accumulate because the normal season that the agricultural investigator desires never seems to arrive. Only when observations have gone on for a number of years can safe conclusions be drawn.

A further direction in which improvement is possible is in cultivation. Reference has already been made to the necessity for increasing the speed of ploughing so as to get the work forward, and enable the farmer to plough just as much as he likes in autumn, or, if he wishes, to get in a bastard fallow or a catch-crop. The motor plough seems the only solution, and as soon as the difficulties of engine construction are got over and the price comes sufficiently low, I think it must displace the horse-plough as inevitably as the railway displaced the stage-coach. Both the soil and the human factors tend this way. So long as a man and two horses, and in some parts of the country a man and a boy and three horses, can only manage to plough an acre a day, it is obvious that the farmer cannot afford to pay more than a small wage for the work; but when a man on a motor plough can do several acres a day a considerably higher wage becomes possible.

The work of ploughing can in many cases be lightened by dressings of chalk, and its effectiveness increased by making a more economical use of tilths left after certain crops. Experiments of this sort have been started at Rothamsted, and might with advantage be made elsewhere. Cultivation is at present the most empirical branch of soil management: the underlying principles are hardly yet known, and the current explanations are for the most part mere guesses, and sometimes not very happy guesses. We want more definitely ascertained facts than we have got before we can begin to straighten out this difficult subject. Further, we want better means of spreading the knowledge of good implements and of testing new ones.

The last economy to which I shall refer is the choice of crops. The farmer grows his crops for profit, and clearly ought to select the most profitable for the purpose. This can only be done by keeping accounts. No crop ought to be grown that does not pay its way; it should be displaced by one that does. On our own farm we find that wheat, oats, and barley are about equally profitable; but the crops in the root- or fallow-break vary enormously—potatoes bringing in most profit, while swedes, on the other hand, are invariably grown at a loss on our land. I believe this would be found not uncommon in the southern part of England. Amos and Oldershaw have recently gone into the cost of silage crops in these conditions. More experiments and inquiries are greatly needed to widen the range of this class of crops, and give us something that will be as useful as swedes but more profitable.

Besides these improvements in crop-production which affect all farmers, even the best, there are two other ways in which we can hope for further developments.

One is to raise up the ordinary farmer to the level of the good one. The average crop of wheat for the country is officially reported to be 32 bushels, but no good farmer would be content with less than 40. If we accept the official average there must be a great amount of wheat grown at much less than the best that is possible even now. A vast amount of educational work has to be done to spread the knowledge of the best methods, varieties, manures, &c. We have all met the type of farmer who had no nitrate of soda and so used superphosphate instead. The county instructor will always retain his important position; unfortunately the more backward his county the less sympathy he is likely to get.

The other is to extend the area of land under cultivation. There are still wastes to be reclaimed, as Mr. Hall is reminding us, while even on farmed land the proportion under the plough each year is only small, and is constantly decreasing. Grass-land only produces about one-half of what arable land yields, and it is imperative to the proper development of the country that some of it should be broken up. The farmer knows this, but he does not put his knowledge into practice. It is futile to abuse him, or to try to find excuses: the better method is to try and find the causes at work. So far as I can see there are two main reasons why he does not adopt all possible devices for increasing crop-production. In the first place he cannot always afford the risk. There is one fundamental distinction between farming and manufacturing that is often overlooked in discussions on the subject. Except in rare cases—sugar beet and some kinds of seeds—the farmer does not grow for contracts, but always for what manufacturers would call 'stock.' The manufacturer makes a contract to supply certain goods at a certain price: he knows what his machinery will do, he can insure against many of his risks, and get out of the contract if others befall him. He knows to a penny how much he will be paid, and so he can calculate to a nicety how much he can afford to spend, and how far he can go in introducing new methods. Now the farmer cannot do this. He cannot be certain what yield or what price he will get. He starts spending money in August on a crop that will not be sold for fifteen months, and he has no idea how much money he will receive in return. The whole thing is a hazard which cannot be covered by insurance. Obviously, then, the farmer must leave a big margin for safety, so he balances his risks by laying down some of his land to grass where the risks are at a minimum. But when you ask him to intensify his methods, and, as a necessary corollary, to break up some of his grass-land, he has a perfect right to ask who is going to bear the extra risk.

I have indicated two ways in which the risks can be reduced, but they will always remain, and their magnitude greatly affects the total production of the farm. Mr. Middleton has recently made a very striking comparison between the average farm produce in Germany and in Great Britain, showing that each hundred acres of cultivated land

	In Great Britain		In Germany
Feeds	45 to 50 people	Feeds	70 to 75 people
Grows	15 tons of corn	Grows	33 tons of corn
	11 tons of potatoes		55 tons of potatoes
	4 tons of meat		4½ tons of meat
	17½ tons of milk		28 tons of milk
	Negligible quantity of sugar		2¾ tons of sugar

The German cultivator is not better than ours, nor is he more enterprising, neither is his soil or his climate better. The result is attained because in Germany the risks are balanced when only one-third of the cultivated area is in grass, leaving two-thirds for arable cultivation: whilst here the farmer believes they can only be balanced by putting two-thirds of the land into grass, and leaving only one-third for arable cultivation.

The problem has been burked in the past, but it must be faced in the future. It is essentially a question of distribution of risk, and it ought not to be

beyond the political insight and economic wisdom of those whose business it is to settle these matters.

Another factor operates against the most intense production, and it is more difficult because it is more deep-seated.

Agriculture is more than a trade; it is a mode of life, and the system in vogue profoundly modifies the life and the outlook of the whole countryside. The farmer lives on the top of his work; he has few evenings away from it, no week-ends, not much holiday and still less prospect of retiring on a fortune; his life has to centre on his farm. Few people set out solely to make money, and most farmers and landowners look to find their pleasure as well as their profit on their land. And so it comes about that things are not always arranged to ensure the maximum of crop-production. Trees and hedges are left because they make up a pleasing landscape: excuses are found for them, and in some places they may be really useful, but over much of the country the land would produce more without them. Copses are left, pheasants are bred, foxes and hares are preserved, and rabbits spared, not because they add to the food-supply, but because they minister to the pleasure of the countryside, and in spite of the facts that the crops would be bigger without them and that the plague of sparrows might be considerably less if it were not for the gamekeeper.

It would be wholly unreasonable to expect the farmer to lead a life of blameless crop-production unrelieved by any pleasure, and it would be social folly of the highest order to make the young farmer exchange the innocent pleasure of an occasional day's shooting or hunting in the country for the night's pleasure in town. I am not going to attempt to justify the syndicate-shoot or the reservation of great areas of land for the pleasure of a few. But I think we shall always have to be content with getting less crop-yields than the land might produce because we must always keep up the amenities and the pleasures of the countryside. We must maintain the best equilibrium we can between these somewhat—but not wholly—conflicting interests.

And as agriculture strikes more deeply at the roots of human life than any mere trade, so agricultural science possesses a human interest and dignity that marks it off sharply from any branch of technology: it is, indeed, one of the pillars of rural civilisation. For the farmer's daily task brings him into continuous contact with the great fundamental processes of Nature, and the function of agricultural science is to teach him to read the book of Nature that lies always open before him, and to see something of the infinite wonder of every common object in the fields around him. The investigator in agricultural science is out to learn what he can of these things, and to pass on his knowledge to the teacher, who in turn has to put it into a systematic form in which the young men and women of the countryside can assimilate it. After knowledge comes control. When we know more about the soil, the animal, the plant, &c., we shall be able to increase our crop-yields, but we shall lose the best of our work if we put the crop-yield first. Our aim should be to gain knowledge that will form the basis of a true rural education, so that we may train up a race of men and women who are alive to the beauties and the manifold interest of the countryside, and who can find there the satisfaction of their intellectual as well as their material wants. If we can succeed in that, we shall hear far less of rural depopulation; instead we may hope for the extension of that type of keen healthy countryman which has always been found among the squires, farmers, and labourers of this country, and which we believe was already increasing before the war. With such men and women we can look forward with full confidence to the future.

The following Papers were then read:—

1. *Soil Protozoa and Soil Bacteria.* By Dr. T. GOODEY.

2. *British Forestry, Past and Future.*<sup>1</sup>

By Professor W. SOMERVILLE, D.Sc.

<sup>1</sup> Published in *The Political Quarterly* for February 1917 (Oxford: The University Press).

3. *The Utilisation of Forest Waste by Distillation.*  
By S. H. COLLINS.
- 

THURSDAY, SEPTEMBER 7.

The following business was transacted :—

1. *Discussion on Motor Cultivation.*

---

2. *Discussion on Ensilage.*

---

3. *Climate and Tillage.* By T. WIBBERLEY.

---

FRIDAY, SEPTEMBER 8.

The following Papers were received :—

1. *Economy in Beef Production.*<sup>2</sup>  
By Professor T. B. WOOD and K. J. J. MACKENZIE.

---

2. *The Relation of Manuring and Cropping to Economy in Meat Production.* By Professor D. A. GILCHRIST.

---

3. *The Inheritance of Mutton Points.*  
By K. J. J. MACKENZIE and Dr. F. H. A. MARSHALL.

---

4. *The Composition of British Straws.*<sup>3</sup> By Professor T. B. WOOD.

---

5. *Losses from Manure Heaps.*  
By Dr. E. J. RUSSELL and E. H. RICHARDS.

---

6. *The Fixation of Nitrogen in Fæces.* By E. H. RICHARDS.

<sup>2</sup> See *Journal of Agricultural Science*, vol. viii.

<sup>3</sup> Published in the *Journal of the Board of Agriculture*.

---

## APPENDIX I.

*The Determination of Gravity at Sea.*—*Report of the Committee, consisting of Professor A. E. LOVE (Chairman), Professor W. G. DUFFIELD (Secretary), Mr. T. W. CHAUNDY, and Professors A. S. EDDINGTON and H. H. TURNER.*

[PLATES VII.—XVIII.]

*Report upon the Comparison of the Aneroid and Mercury Barometers.*  
*Drawn up by the SECRETARY.*

1. *Preliminary.*

IN 1866<sup>1</sup> attention was drawn to the possibility of employing an aneroid in conjunction with a mercury barometer for the measurement of gravity at certain land stations, but the variability of the elastic properties of the metal boxes constituted a difficulty to its successful application. As it was the opinion of meteorologists that aneroids had been greatly improved in material and in construction, I took advantage of a generous offer from the Cambridge Scientific Instrument Company to provide an aneroid wherewith to test the method anew, this time at sea, during the voyage of the British Association to and from Australia in 1914.

It had scarcely been hoped that the investigation would lead at the first attempt to the successful determination of gravity at sea, but it was hoped to gain experience and information which might serve to disclose any defects which might be capable of subsequent remedy. On account of the exigencies of war-time, the report has been condensed and the bulk of the tables omitted. The original report is filed at the offices of the British Association, where it may be consulted by those closely interested in the subject. It sets forth the present state of science with regard to the aneroid method of measuring the intensity of gravity over the oceans, and the primary object in compiling it has been to place in the hands of future investigators a record of the experience already gained.

The results, which are discussed with some reserve in sections 8, 9 and 10, have, however, an interest of their own, and future work will be eagerly awaited to see if the fall in the value of gravity between Australia and India is real, or due to a systematic error to which the aneroid is liable, or to some other uncorrected vagary of this instrument.

In future experiments fuller acquaintance with the lag and the pumping of the aneroid barometer for long periods previous and subsequent to the voyage should solve the question whether Helmert's formula holds good or not over the deep oceans. At present the indication, though not the conclusion, is that it does not, gravity being apparently less over the deep ocean than over land areas; over inland seas, on the other hand, the normal value may be exceeded.

<sup>1</sup> Von Wüllerstorff Urbair, *Zeitschrift der österreichischen Gesellschaft für Meteorologie*, Band I, 1866.

## 2. *The Marine Barometer.*

In the original Report the characteristics and behaviour of this instrument are considered with particular reference to the work of Stokes, Chree, and Hecker. It must suffice here to indicate the nature of the discussions.

1. *Construction.*—Hecker claims advantages over the Kew pattern for a capillary constriction with symmetrical funnel-shaped ends and a large space above the mercury.

2. *Lag.*—It is clear from Stokes' and Chree's investigations upon the lag of marine barometers at land stations that the viscous resistance to the flow of mercury in the capillary is not the dominant cause of lag. Surface tension effects must be taken into account.

Chree concludes from land observations that the barometer with the smaller lag possesses a smaller mean error. Hecker, from sea observations, comes to the opposite conclusion.

Without going so far as Chree in saying that 'at sea the effect of lag upon the average marine barometer is exceedingly small,' the present research favours the view that at sea the lag is less important than on land, probably because the regular throbbing of the engines is more efficacious in eliminating unsymmetrical surface tension effects than perfunctory tapping on land. In view of the theoretical uncertainty and the practical difficulty of reading a barometer at sea, it would appear preferable to place the barometer and the other apparatus with which its readings are to be compared in a chamber in which the rate of change of pressure can be controlled and measured and reduced to a small and determinate quantity, if not to zero, rather than to trust to measurements of the variations of the atmospheric pressure, which, since the ship is moving, are likely to be more rapid even than those encountered by a fixed barometer at a land station, and which are seldom linear for any considerable period.

It is suggested that the chamber should be large enough to contain photographically recording aneroid and mercury barometers and furnished with an auxiliary aneroid which could be used as a regulator; by means of an electric contact operating a relay working a rotatory pump it should be possible to maintain a nearly constant pressure.

The error introduced by fluctuating pressure is shown in fig. 14 for a harbour station; compared with other consecutive *Morea* deviations at sea, fig. 9, the deviations are large.

3. *Pumping.*—A vertical acceleration of the barometer may be occasioned by the rise or fall of the ship as a whole, or by rolling and pitching about a longitudinal and transverse axis respectively, if the apparatus is not in the centre of the ship. The vertical motion adds an acceleration to that due to gravitational attraction, and the problem is complicated by the fact that this dynamic acceleration may not be symmetrical.

The constriction is introduced for the purpose of freeing the static attraction from the dynamic acceleration, but though it reduces it does not eliminate the pumping. The damping is always such that the free vibration of the mercury is aperiodic.

When the mercury is pumping it is necessary to take the mean of successive maxima and minima readings. The practice of reading only the highest (or lowest) point, which at one time received official sanction, is deprecated. It is difficult to set and read the barometer and to record the reading in the half period of the wave, but with a dial form of instru-



ment it is not impossible. If successive readings cannot be taken, an equal number of maxima and minima should be measured. It would be preferable to employ an assistant to read and record the dial indications, but if the experiment is conducted in a refrigerator the presence of a second observer must be avoided. Telephonic communication with an assistant outside should be arranged.

If the instrument records photographically the film may be studied at leisure, and only those portions chosen for measurement in which the pumping is small and fairly regular. It is found simplest not to measure each crest and hollow separately, but to set the wires in the eyepiece first along the mean line of crests and then along the mean line of hollows: these can be judged with considerable accuracy. The mean of these two readings is then taken as the level of the undisturbed mercury surface. Unfortunately the photographic record involves difficulties, arising from the density of the photographic image and from parallax.

If the ship's motion is regular, and the barometer free from unsymmetrical errors, it is impossible to improve upon the height of the barometer as given by the mean of the lines of crests and of hollows. Hecker, however, finds that the Kew pattern barometer gives unsymmetrical pumping, but his experimental evidence is open to criticism. (See O. R.) When the ship's motion is irregular, the pumping is necessarily unsymmetrical. It is doubtful if it is practicable to deal usefully with observations made when the photographic trace shows the dissymmetry to be marked. A prolonged comparison between the readings of the marine barometer carried on board a ship straining at anchor in seas of all kinds, and a standard barometer on a neighbouring pier or headland, might settle this point; or it might be feasible to imitate the motion of a ship with the aid of a lift oscillating about the floor containing a standard barometer.

Rolling and pitching produce pumping both by adding to the vertical acceleration of the point of support of the apparatus and by throwing the barometer slightly out of the vertical position, an inevitable accompaniment of the motion, since friction at the suspension cannot be completely avoided. The former, which is the more important, is dependent upon the position of the apparatus in the ship, and could be eliminated by taking the mean of simultaneous readings of similar barometers placed equidistant from the two axes, and on opposite sides of them. The usefulness or otherwise of introducing linear terms to correct for the various types of pumping is briefly discussed in the original Report.

4. *Temperature Correction.*—Since an error of  $0.1^{\circ}$  introduces an uncertainty in the value of gravity of  $.02$  cms./sec.<sup>2</sup>, accurate measurement of the stem temperature is essential. Inequalities of lagging may occasion a temperature gradient which is difficult to allow for, and it would be preferable to immerse the barometer in a well-stirred water bath. This would obviate difficulties such as are occasioned by the approach of the observer, which is especially troublesome if the observations are carried out in a refrigerator, since there is usually a difference in the temperature of the attached thermometer and that of the mercury in the stem of the barometer.

5. Other matters to be considered are the capacity correction, capillary depression, pressure of mercury vapour, and the loading of the ship. The consumption of fuel and food lightens the ship and may tilt the apparatus if it is not suspended.

### 3. *The Aneroid Barometer.*

This instrument was constructed by the Cambridge Scientific Instrument Company at very short notice. It was then kindly placed at the disposal of the writer by Mr. Horace Darwin. Fig. 1 represents its main features.

The series of boxes B mounted on the horizontal axis A is suspended by the thin steel springs CC, 0.45 mm. thick, from a pair of square bars shown in section, which are supported by pairs of pillars DD mounted on a solid metal base EE. The axis is under no other constraint, but a loose link, pointed at each end, and fitting into cones on either side, makes a connexion between it and the screw which passes through one end of the base. The extension of the boxes, which is a measure of the atmospheric pressure, is measured by finding the amount through which the divided head H must be turned in order to press the other end of the axis against the stop G. Contact is determined by flicking a spring along one side of which, at a distance of 7.5 cms. from the support, the contact piece G is fixed, and as the screw head is slowly turned, noting the instant at which a tinkle indicates that the axis is in contact with the vibrating spring. If the boxes pump there is a tendency for the contact to be registered too early, which gives too low a value for the pressure.

To obviate the effects of the ship's motion, Mr. Horace Darwin devised the suspension also shown in fig. 1.

The box K, containing the instrument, was suspended by springs from three arms at 120° with one another, which were united over a central pivot supported upon a frame fixed to a firm base. A dash-pot L containing oil and a plunger to damp the vertical vibrations was fixed to the top of the instrument case.

During the voyage a level and sliding weights were added and a thermometer arranged to record the temperature within the case. The instrument gave very steady readings (consistent to 0.025 millibars at land stations), but at sea the pumping was unfortunately very apparent.

The calibration of the instrument in a closed chamber is difficult, as it requires two hands for every manipulation, one for turning the milled head and the other for flicking the spring by a device which extends through the wooden side of the box.

Though, as will eventually appear, the instrument has certain failings, its investigation at sea has brought to light certain points which will prove of value to the future designing of an instrument of sufficient delicacy for the object of this research.

### 4. *The Observations.*

As explained in the Interim Report (1915), the apparatus was carried in *ss. Ascanius* on the outward and in *R.M.S. Morea* on the homeward voyage. Observations were made three times a day as a rule during both voyages. Each set of observations consisted of the following :—

- (1) Reading of temperature of special chamber from outside by thermometer projecting through wall.
- (2) Entering chamber and closing door quickly.
- (3) Temperature of aneroid and five observations of the pressure recorded.

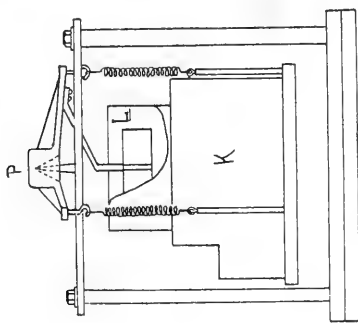

Suspension of the Aneroid Barometer.

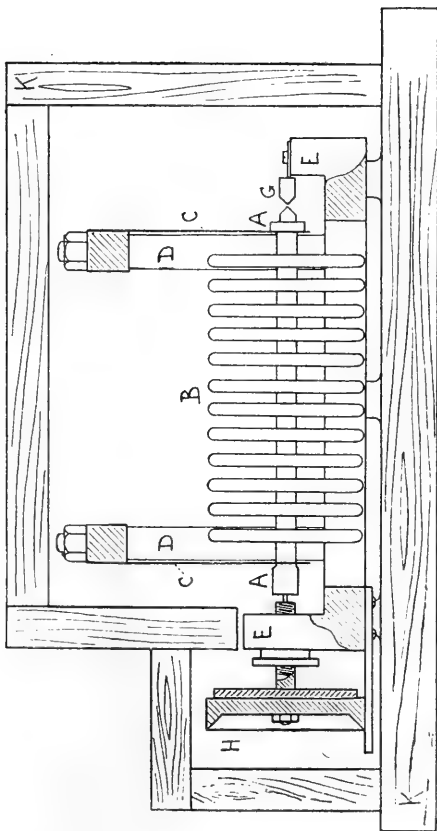

The instrument is cut away in places to show the central section (shaded).

FIG. 1.

THE ANEROID BAROMETER.

(4) Temperature of mercury barometer and ten readings taken.

(5) Five readings of aneroid and its temperature recorded.

(6) Observations (made by the ship's officer) of speed, course, depth, latitude and longitude.

When the barometers pumped more than usual a larger number of observations were recorded.

In Table I. are typical sets of readings.

TABLE I.  
TYPICAL SETS OF READINGS.

July 19, 1.45 P.M.				Sept. 21, 11.55 A.M.				Oct. 5, 3.40 P.M.			
Aneroid		Mercury		Aneroid		Mercury		Aneroid		Mercury	
Temp.	Reading.	Temp.	Reading.	Temp.	Reading.	Temp.	Reading.	Temp.	Reading.	Temp.	Reading.
4°·75	553·4	278·8	1002·10	6°·1	599·6	—	1014·08	8°·8	600·9	282·0	1013·10
—	3·5	—	3·60	—	600·2	—	4·01	—	0·9	—	·12
—	2·5	—	3·75	—	599·9	—	4·30	—	0·9	—	·15
—	4·0	—	2·48	—	600·0	—	3·90	—	0·9	—	·16
—	3·8	—	2·75	6°·2	599·7	—	4·30	8·8	601·0	—	·16
—	5·5	—	3·65	6°·3	598·2	279°·6	3·85	8·9	0·8	282·2	·16
—	4·8	—	2·35	—	599·4	—	4·38	—	0·9	—	—
—	3·8	—	4·45	—	599·0	—	3·86	—	0·9	—	—
—	4·3	—	4·00	—	599·0	—	3·80	—	0·9	—	—
4°·90	3·7	279·0	2·21	6°·5	598·7	—	4·30	8·9	0·7	—	—
Means 4°·82	553·73	278·9	1003·13	6°·3	599·37	7279·6	1014·08	8·85	600·88	282·1	1013·14

Table II. gives the means of the land and harbour station observations which were used for the calibration of the aneroid.

Table III. gives the observations made at sea.

[These tables are not reproduced in full; the original Report should be consulted for details.]

### 5. The Reduction of the Aneroid Readings. .

The aneroid was not delivered to the experimenter until the eve of his departure for Australia, when a test was out of the question. Fortunately the instrument had passed through the hands of Mr. F. J. W. Whipple, who had compared its reading with that of a standard barometer at the Meteorological Office. Comparisons with the mercury barometer were made at each port of call on the voyages; and subsequently in University College, Reading, and at the Meteorological Office, London: Table II. The results show considerable changes in the value of the aneroid reading corresponding to any particular pressure, the readings rising with time. The problem has been to find the value in millibars of an aneroid reading at any stage in the voyage.

TABLE II.—TYPICAL LAND AND HARBOUR OBSERVATIONS.

Obs.	Date	Time	Mercury Barometer				Aneroid Barometer				Deviations from Gravity at Lat. 45°			
			Temp.	Mean Reading	Reading corrected for Temp.	Reading corrected for Temp. and Gravity	Temp.	Mean Reading	Pressure calculated from Aneroid Readings	$p_a$	$p_b$	$p_c$	$\delta g_a$	$\delta g_b$
R.M.S. <i>Morea</i> , Fremantle Harbour. Lat. 32° 3' S. Long. 115° 44' E.														
Sept.														
n	14	{ 11.30 a.m.	279.4	1021.00	1021.77	1020.62	5° 00	638.20	1020.69	1020.52	1020.65	-1.04	-1.20	-1.08
o	14	{ 2.19 p.m.	280.1	1019.48	1020.11	1018.95	6° 21	630.98	1019.12	1018.94	1019.07	-0.95	-1.11	-0.99
											Mean $\delta g$	-0.99	-1.16	-1.04
											( $\delta g - \delta \gamma_0$ )	+ .14	- .03	+ .09
R.M.S. <i>Morea</i> , Colombo Harbour. Lat. 6° 54' N. Long. 79° 50' E. { $g'' = 978.161$ (Budik, 1897) $\gamma_0 = 978.105$ , $\delta \gamma_0 = -2.512$														
d <sub>1</sub>	22	{ 5.22 p.m.	282.4	1011.91	1012.12	1009.57	9° 2	588.23	1009.71	1009.52	1009.59	-2.34	-2.53	-2.45
e <sub>1</sub>	23	{ 5.43 p.m.	282.6	1011.70	1011.87	1009.6	9° 9	587.12	1009.46	1009.27	1009.32	-2.34	-2.53	-2.47
											Mean $\delta g$	-2.34	-2.53	-2.46
											$\delta g - \delta \gamma_0$	+ .17	- .02	+ .05

$\gamma_0$  and  $\delta \gamma_0$  represent the theoretical value for gravity and its deviation from the value of gravity at Lat. 45°;  $g''$  the observed value of gravity by pendulum observations.

TABLE III.—VOYAGE OF R.M.S. *Morea*. TYPICAL OBSERVATIONS AT SEA.

Observation	Date	Time	Latitude South	Longitude	Depth m.	Course	Speed k.	Mercury Barometer		Aneroid Barometer		Pumping		Temp. Change	
								Temp.	Mean Reading	Temp.	Mean Reading	Mercury	Aneroid	Merc.	An.
p	14	6.50 p.m.	31° 19'	114° 36'	300	N.W.	16	278.1	1019.45	5.06	632.90	.30	.07	—	—
r	15	6.27 p.m.	26° 38'	109° 52'	6130	N.44W.	16.25	279.1	6.70	644.71	.62	.15	—	—	-2

TABLE IV.

Observation	Mercury Barometer corrected for Temp.	Pressure in mbs. from Aneroid Reading				$\delta g = (p - B_s)g_0/B_s$				Corrections for Station Errors				Correc- tion for Ship's Motion	$\Delta ig = \delta g + m$				$\Delta_{2g} = \Delta ig + l$																
		B <sub>s</sub>	P <sub>a</sub>	P <sub>b</sub>	P <sub>c</sub>	$\delta g_a$	$\delta g_b$	$\delta g_c$	$\delta g_d$	l <sub>a</sub>	l <sub>b</sub>	l <sub>c</sub>	l <sub>d</sub>		$\Delta ig_a$	$\Delta ig_b$	$\Delta ig_c$	$\Delta ig_d$		$\Delta_{2g}a$	$\Delta_{2g}b$	$\Delta_{2g}c$	$\Delta_{2g}d$												
p q r	1023.43 1021.06 1023.90	1019.54 1019.99 1022.08	1019.36 1019.80 1021.89	1019.49 1019.93 1022.02	-85 -102 -175	-1.62 -1.20 -1.92	-90 -1.08 -1.81	-038 -043 -045	+13 +12 +11	+04 +04 -04	-07 -07 -07	.92 1.09 1.82	-1.10 -1.28 -1.99	.97 1.15 1.88	.96 1.14 1.87	.94 1.16 1.88	.93 1.11 1.24																		
																								∆c.											

The methods will only be briefly referred to here. From Table II. curves were drawn connecting the readings of the aneroid at land stations with the corresponding atmospheric pressure in millibars obtained from the reduced readings of the marine barometer (fig. 2); the graphs are nearly linear, the slopes varying with time. It was found simplest to correct separately for (a) alteration of scale division value with time, and (b) creeping of the zero. Details of the method are given in the full Report. The calculated pressures corresponding to a given aneroid reading are designated  $p_a$  in the Tables.

A second method lay in drawing fig. 3 from the data of Table II. and fig. 2, relating the aneroid reading with the data of observation for particular values of the pressure. The degree of imperfection of the aneroid method of determining 'g' is shown by the deviations of individual readings from the graphs. Some of the discrepancies may be due to the transport and re-setting up of the instrument between the Meteorological Office, s.s. *Ascanius*, R.M.S. *Morea*, and Reading. When the observations were continuous the readings are more consistent—hence more reliance is to be placed on the *Morea* observations. During the *Ascanius*' voyage the suspension and levelling were altered several times.

The reduction factor being known at any date, it was simple to find the atmospheric pressure corresponding to any aneroid reading at a given date. These pressures are designated  $p_b$  in the Tables.

A further value for an aneroid division was calculated on the assumption that the *Morea* readings could be treated quite separately from the rest, and that the graph was a straight line; this appeared to be an extreme assumption providing a useful check upon the other methods. These values are designated  $p_c$ . When corrected for station errors there is very little difference between the results of the different methods of treatment.

The aneroid was not suitable for the investigation of its properties in an experimental chamber, consequently other means were employed for investigating the effects of (1) temperature; (2) rate of change of temperature; (3) rate of change of pressure (see O.R.). The pumping of the aneroid was lessened but not obviated by the mounting; though the boxes were on a horizontal axis placed parallel to the keel, rolling affected the reading. Except in harbour its pumping was less than that of the mercury barometer. The effect of different ships is shown in fig. 4. Though the aneroid was mounted on springs on R.M.S. *Morea*, the vibration of the ship had a greater effect upon the pumping of the aneroid.

But the most troublesome feature of the pumping is that contact is registered too early, as already explained. The amount depends upon the relative frequencies of the pumping and of testing. When the head is turned very slowly contact occurs only at one end of the travel of the boxes; great rapidity would be required to make it equally probable that the other end of the travel is recorded. The error is indeterminate, but the value of gravity is systematically too low by a small amount.

In a subsequent section this point is further considered. For inclusion in the final diagrams the criterion has been an amount of pumping half that permitted for the mercury barometer. For future work an aneroid recording photographically by a reflected spot of light method is recommended. The essential thing is to measure the extremes of the pumping on each side of the mean.

### 6. Calculation of the value of Gravity from the readings of the Aneroid and Mercury Barometers.

The height of the mercury barometer reduced to 0° C. and corrected for scale errors but not for latitude is given in the column headed  $B_s$  in Table IV.

As latitude has not been allowed for, the units are not true millibars.

The corresponding atmospheric pressure is given in the same Table under the heading  $p_a$ ,  $p_b$ , or  $p_c$ , according to the method of reduction. The value of gravity is found from the following equation:

$$g = g_{45^\circ} \times p/B_s,$$

$$\text{or } \frac{g - g_{45^\circ}}{g_{45^\circ}} = \frac{p - B_s}{B_s},$$

$$\text{or } \delta g = \delta p \frac{g_{45^\circ}}{B_s}.$$

Where  $\delta g$  is the deviation from the value of gravity in latitude 45°. In Table IV. the columns  $\delta g_a$ ,  $\delta g_b$ ,  $\delta g_c$ , are calculated from the values  $p_a$ ,  $p_b$ , and  $p_c$ , respectively.

The application of corrections to these on account of the ship's motion and the errors at land stations is discussed in later Sections.

### 7. Correction for the Ship's Horizontal Motion.

The ship's motion along the surface of the water involves a correction for gravity equivalent to the extra centrifugal force upon the ship.

The modification of the curvature of the ship's course relative to the centre of the earth as she sails over the crests or hollows of ocean swells operates as a pumping term and is treated in the same way. The error is small if the swell is symmetrical and if the mean level of the mercury be taken.

The form in which the term is introduced in the present investigation is  $2 \omega v \cos \lambda \sin \alpha$ , where  $\alpha$  is the angle between the true north and south line and the direction of the ship,  $\omega$  the angular velocity of the earth's rotation, and  $\lambda$  the latitude. It neglects the term involving the square of the ship's velocity and the component of the ship's velocity in the North-South direction. The appropriate correction for each observation is included in Table IV. under the column headed  $m$ .

The theoretical reasons for introducing this term were pointed out by von Eötvös, but as its introduction appeared to cause the results of Hecker's determinations of gravity at sea to diverge appreciably from Helmert's formula doubt was cast upon the necessity for it.<sup>2</sup> Voyages on the Black Sea enabled Hecker<sup>3</sup> to test this point, and he found that the barometric height differed by .08 mm. if the ship went east instead of west, and therefore that it was necessary to include the term.

Any uncertainty in measuring the velocity and direction of the ship

<sup>2</sup> Helmert, *C. R. 6ième Conférence générale de l'Association Géodésique Internationale*, 1909, p. 22.

<sup>3</sup> *Loc. cit.*



occasions an error which varies according to the latitude. For equatorial regions the gravity error due to an error of one degree in the course varies per knot from '00013 when the course is N. or S. to '000012 when it is E. or W. An error of one knot in determining speed produces a gravity error which varies from 0 on a meridian course to '0073 on an E.-W. course. Elsewhere these amounts are to be multiplied by the cosine of the latitude.

While the average speed of the ship over 24 hours is capable of measurement with considerable accuracy from the dead reckoning, the speed during the five minutes required for an observation is less certain.

The chief difficulty lies in the uncertainty of the tides, and it would be preferable to anchor the ship before starting the observations; it is feared that this can only be done on a few occasions, but otherwise, especially in places near the coast, like the Scilly Isles, an appreciable error is involved. There may frequently be an uncertainty of about '015 cm./sec<sup>2</sup>, which, though unimportant in the present research, may in future work prove a relatively large source of error.

For high accuracy it is very essential to secure close co-operation between the observer and the executive officers of the ship.

If the speed of the vessel is ascertained by dead reckoning, pitching introduces a small modification of the instantaneous values calculated above, and tends to diminish them, but the precise amount is incalculable.

### 8. Variation of Gravity with Latitude.

In Table IV. the deviations of gravity from its value in latitude 45° are shown corrected for the ship's motion in columns headed  $\Delta_{1g_a}$ ,  $\Delta_{1g_b}$ ,  $\Delta_{1g_c}$ , according to the aneroid method of reduction. These values, together with the theoretical curve derived from the formula

$$\gamma_0 = 978.030 \left\{ 1 + 0.005302 \sin^2 \lambda - 0.000007 \sin^2 2 \lambda \right\},$$

are plotted in figs. 5 (1), 6 (1), 7 (1). The large open circles represent harbour observations, the small circles represent sea observations, of which those which are open are less reliable than those which are black. The aneroid method is clearly capable of showing the general trend of gravity with latitude, but we try to push it further:—fig. 5 (1) showed that many of the harbour readings were too high, which threw doubt upon the method of reduction, and led to the trial of the other methods already described and shown graphically in figs. 6 (1) and 7 (1). In none of these is there complete coincidence between the harbour observations and the theoretical curve, though in fig. 6 (1) they lie close to it; this is therefore the most satisfactory graph, and it shows a defect of gravity between Bombay and Australia.

The reason why the harbour observations show deviations is not clear; it may be that the effect of lag upon the mercury barometer is more serious when the ship is at rest, when changes of atmospheric pressure introduce considerable errors, fig. 14, or it may be that there are short period changes in the elastic properties of the aneroid. Though there is no obvious reason why any short period variation should begin and end during a stay in port, the only possible way of improving the curves lay in plotting the station errors against a horizontal scale,—assuming

that the errors grew continuously and linearly with time between the stations, and obtaining the corrections to be applied to any period of the voyage from the graph. These are given in Table IV. under the columns headed  $l_a$ ,  $l_b$ , and  $l_c$ , and the final corrected values in columns  $\Delta_2g_a$ ,  $\Delta_2g_b$ , and  $\Delta_2g_c$ .

In figs. 5(2), 6(2), 7(2) these values are plotted against the latitude of the ship at the time of observation, the stations chosen as standards being indicated by arrows at the base of the diagrams. Sydney and Reading are omitted.

The mean of the Adelaide and Fremantle Harbour observations was chosen as a standard (*i.e.* they were made equidistant from the theoretical curve) on account of the paucity of the observations at these two ports. For certain reasons the Adelaide readings are the least reliable, and I now believe it would have been preferable to have taken the Fremantle Harbour observations as correct.

Even when, as in fig. 5(2), only the Australian ports, Bombay, Aden, and Tilbury were chosen as reference ports, the intervening stations Colombo, Malta, Suez Canal, and Plymouth Harbour fall close to the theoretical line, which to some extent justifies the assumption made in correcting for station errors; moreover, the continuity of the dots between Australia and Bombay suggests that in this region there has been no sudden change in the properties of the aneroid.

In order to see if the systematic error introduced by the pumping of the aneroid could be responsible for these low values of gravity, the deviations from the theoretical formula were plotted against the pumping, *i.e.* the maximum difference from the mean of each set of aneroid readings, fig. 8. No general dependence is to be discerned, for though a defect of gravity is usually accompanied by moderate pumping there are almost as many instances of excess values under the same conditions. A further examination showed that the defects in gravity between Fremantle and Aden were greater (nearly twice as great) than could be explained even on the assumption that the aneroid readings were too low by an amount as large as the extreme measured pumping of that instrument. The only evidence in favour of a connexion between the pumping and the defect of gravity is derived from the early part of the voyage of ss. *Ascanius*, fig. 12, when the pumping was great because the aneroid was not mounted on the spring support. On this occasion, the deviation from the theoretical curve was great also, but it is just as possible that this was due to the instrument not having been levelled. On the other hand, the curves reproduced in figs. 9 and 13, in which pumping and defect of gravity are plotted together against time, show little correlation, and on the whole, the evidence is against this particular instrumental defect having vitiated the results; it is possible that over-caution has been shown in labouring this point; nevertheless, it is one which must not be overlooked in the design of future aneroids to be used for gravity determinations at sea.

Thus, as far as the evidence goes, the conclusions arrived at by Hecker as a result of his investigation by means of the boiling-point thermometer are not confirmed, and one may seriously doubt whether Helmert's formula holds over ocean depths as closely as has been supposed.

3. *Variation of Gravity with Depth.*

In fig. 9 are shown the contours of the ocean floors and the corresponding deviations of gravity from the theoretical formula. As the horizontal line represents time, the steepness of the contour is not accurately represented. Each circle represents one observation, an open circle indicating that the observation is not quite so reliable. The results are to be accepted with caution, for reasons already discussed. Nevertheless, there is a certain consistency about the results which justifies their being brought forward. There is, for example, a well-marked defect of gravity over the Indian Ocean and over its northern extension, the Arabian Sea, and there is a surprising agreement in the contours of the lines of soundings and of gravity, which is particularly noticeable in the part of the voyage from Fremantle to Aden, and would have been more pronounced if the Fremantle observations had been taken as reference points. It is with considerable satisfaction that I note a certain measure of agreement between these results and those made by means of the apparatus I have described elsewhere.<sup>4</sup> The only part of the voyage subjected to a test by this instrument was the approach to Colombo and thence onwards half-way to Bombay. A comparison of the two is shown in fig. 10. The dotted line represents the aneroid results taken from fig. 9, and the black circles the observations made with the 'gravity barometer.' The agreement is not complete, and I have emphasised it by leaving as open circles those which are not in accord. The discrepancy shown by the last three observations may perhaps be accounted for by a break in the thread of mercury which ultimately led to the abandonment of the test (*loc. cit.*).

In view of this corroboratory evidence for a fraction of the voyage, I feel justified in venturing upon the following brief discussion of the results obtained from the aneroid method, especially as it indicates the type of problem involved in an investigation of this nature.

Starting from Fremantle the ocean descends to 6000 metres, and gravity falls too; this defect of gravity is displayed until the island of Ceylon is approached, and indeed continues after the water has got shallow, perhaps due to the influence of the western slope of the mountains of which Adam's Peak is the prominent feature. In Colombo Harbour the value is high again, though that port is not much farther from the mountains. On leaving Colombo the depth increases rapidly as the Gulf of Manar is traversed, and gravity falls at the same time in a very remarkable way. The subsequent shoaling as India is approached is accompanied by a rise in gravity, but not quite to the normal value, and there is a persistent defect until Bombay is reached. The suggestion is made that the range of mountains along the Indian coast, the Western Ghâts, is concerned with this defect, which curiously enough reaches its maximum where Mount Hadar 6215 feet, and another 6660 feet, slope down to the coast from summits about 25 miles inland. North of lat.  $14^{\circ} 30'$  the coastal range is less pronounced and tails off considerably before reaching Bombay, where gravity regains its normal value (Bombay was taken as a standard station).

The dip down of the contour into the Arabian Sea coincides with a deficiency in the value of gravity; the oscillations are probably due to experimental errors, but the mean curve is considerably below the normal

<sup>4</sup> 'Apparatus for the Determination of Gravity at Sea.' Duffield. *Roy. Soc. Proc.*  
1916

line, and the contour of the bed of the Arabian Sea and the Gulf of Aden is followed closely. The floor of the Red Sea is nowhere deep, and there is a defect of gravity which is very pronounced as a coral shoal is approached, very small in the centre of the sea, and again marked in the neighbourhood of Suez. In the Canal a defect of gravity appears which is not easily explicable if it is real. The Mediterranean shows an excess at first, but a defect over the deepest part. The approach to Malta is characterised by a rise in the value of gravity (in conformity with the known tendency of island stations), which increases before leaving the shallow water south of Sicily and again when on the ridge south of Sardinia. One may infer either that this ridge is of great density, which may account for its capability of supporting Corsica-Minorca, or else that the graph should have been dropped down on account of some vagary of the aneroid, when the gravity and sea-floor contours would fit together reasonably. In either case some tendency for gravity to increase as the bed of the Mediterranean rises is apparent. The approach to the Straits of Gibraltar occasions a pronounced fall in the value of gravity; such has previously been observed on the edge of a land mass, even though the water is shallow, *e.g.*, south of Colombo and Bombay and in the Red Sea.

Finally, in the extension of the Atlantic Ocean known as the Bay of Biscay there is an indication of a defect in gravity, but not as pronounced as in the Indian Ocean, where the depth is the same.

In fig. 11 the depths are plotted against deviations from the normal values of gravity. For shallow water there is little regularity, though a general reduction below the normal value, perhaps corresponding to the known defect of gravity at coastal stations, but beyond a certain depth a diminution of gravity is associated with increasing depth.

The results, if confirmed, will very seriously limit the application of the isostatic theory of the earth's equilibrium, since over the Indian Ocean the value of gravity is  $\cdot 2$  to  $\cdot 3$  cms./sec.<sup>2</sup> less than that demanded by the mathematical expression of Pratt's hypothesis, a very appreciable amount in gravitational units. The compensation appears to be less complete than the simple theory had led us to hope.

The above suggestions are put forward tentatively, and with due regard to the nature of the evidence upon which they are based.

#### 10. *The Preliminary Experiments on ss. Ascanius.*

Various changes in the disposition of the aneroid were made during the voyage, and additions were introduced as experience was gained; for example: (1) the instrument was mounted on the support designed for it instead of being allowed to rest on the table, an advantage clearly shown in fig. 12; (2) oil damping was substituted for air damping; (3) a level and sliding weights were added to enable the instrument to be adjusted horizontally whenever necessary. Discontinuities were thus introduced which probably account for the discrepancies in the harbour station observations in Cape Town, Fremantle, and Adelaide (fig. 3). On account of these the reduced results are scarcely of sufficient value to justify a description of them in further detail than is conveyed in figs. 12 and 13, the data for which have been obtained from the first method of reduction described above:—

(1) The low values of the north latitude observations, fig. 12, are due to

the change in the disposition of the aneroid when mounted on springs, not to the pumping being greater, since equal pumping later on occasioned no such drop in the value of  $g$ . Las Palmas shows a high value with a defect on approaching and leaving the island, perhaps because the island is built up of material taken from the neighbourhood, but probably this is accidental.

(2) The non-success of the reduction of the aneroid for the latter part of the voyage is shown by the impossibly large departure from the theoretical values shown in fig. 12.

(3) The observations have been corrected by taking those of Cape Town, Fremantle, and Adelaide as reference stations. Plotting the deviations from the theoretical curve against ocean depths, fig. 13 has been obtained.

The defect of gravity between  $0^\circ$  and Cape Town may be due to the absence of a port of reference to the left of the diagram. It is, however, suggestively in agreement with the *Morea* readings in deep water, fig. 9.

(4) The continuity of the observations between Cape Town and Fremantle (fig. 13) was broken by various disturbances to the instruments already mentioned, but the average divergence of a reading from the theoretical value is not more than  $\cdot 03$  cms. sec.<sup>2</sup>; if these readings stood alone they would support Helmert's formula and Hecker's conclusions, though the probable error is large in this part of the voyage, the differences between successive readings sometimes amounting to such improbable values as  $\cdot 6$  cms./sec.<sup>2</sup>. This may be attributed to the pumping of the mercury barometer, which was so large that a very large proportion of the readings would have been omitted if the same standard had been demanded as was required for the *Morea* observations. The pumping of the aneroid was, however, within the limits allowed. Between Fremantle and Adelaide the theoretical formula is followed approximately, high values being observed as the ship rounded Cape Leeuwin, as in the *Morea* observations.

### 11. *Temperature Regulation on Board Ship.*

The Interim Report of the Committee (1915) paid a tribute to the generosity of Messrs. Alfred Holt & Sons, of the Blue Funnel Line of steamships, for erecting a special chamber for these experiments in the refrigerator of ss. *Ascanius*.

The chamber was conveniently situated on the level of the dining saloon, and was a little above sea-level. Access to it was through the 'handling-room,' which was at a temperature of about  $40^\circ$  F. The chamber had its own system of brine pipes, which could be connected up to an auxiliary engine, and it was possible to adjust the number of pipes in operation within the chamber.

An electric fan placed on the floor kept the air stirred continuously within. The temperature was read from without by a thermometer which could be withdrawn through a hole in the wall. This was read at intervals seldom greater than one hour throughout the whole of the twenty-four hours by one of the refrigerating engineers, and brine pumped through accordingly.

Fig. 15 is shown as an example of the success achieved in regulating and in compensating for the entrance of the observer. I am indebted to Mr. Latham for this diagram, which was drawn from his observations. It will be seen that it is possible to maintain an experimental chamber

at sea sufficiently constant for most experimental purposes. If these experiments possessed no other value they would be still useful from the demonstration of this result. One may congratulate Messrs. Alfred Holt also upon it.

The outbreak of the war occasioned the transfer of the apparatus to the refrigerator of the P. & O. R.M.S. *Morea* (see Interim Report). It was difficult to instal the apparatus, as the refrigerator was only 14 feet above the keel and 12 feet below sea-level, and was approached by three narrow ladders, but, thanks to the care of Mr. Charlewood and his mate (butchers' department), this was safely accomplished. The writer obtained permission to partition a good space of the handling-room, but as it was done with matchboarding it did no more than isolate it from the hanging joints of meat and other articles which are more appreciated on the upper decks than in the bowels of the ship. At midnight, alone in these depths, on a rough night, with carcases waving to and fro in the light of a ruby lamp (some of the other apparatus was photographic), a whizzing fan blowing a blast of snow and air, and the floor frozen and slippery, the conditions were not those to be deliberately sought by a scientific investigator.

The chambers on the *Morea* were cooled by air which was blown into and extracted from them. The same facilities for maintaining a constant temperature were not available, and so the two systems cannot be properly compared. I think, though, that the brine system is more satisfactory and more rapid in compensating for the introduction of the observer. It was found preferable on s. *Ascanius* to introduce the brine at a temperature as little below that required by the room as possible.

As the engineers on R.M.S. *Morea* did not find it practicable to run the engines more than twice or three times a day, I arranged my fan in such a way that it sucked from a neighbouring cold-chamber a quantity of cold air which it was hoped would compensate for my entry, but it did not make much difference.

It will be seen from fig. 16 that the conditions in the experimental chamber on the homeward voyage were much less favourable as regards temperature.

## 12. *Influence of Gravity Deviations upon Meteorological Phenomena.*

Though the effect is necessarily very small, it is just possible that under some conditions the influence of variations in gravity upon meteorological conditions may prove appreciable. For example, the change in the value of  $g$ , which a body experiences when it moves E. or W., will apply to the motion of a mass of air. A current going east (*i.e.* a westerly wind), being attracted less, tends to rise, whereas an easterly wind tends to descend. A velocity of 13.7 knots per hour in an E. or W. direction at the Equator is equivalent to a change of barometric pressure equal to 0.1 mb.

There is a considerable difference between the gravitational attraction upon a mass of air moving N. or S. according to whether it assumes the velocity of the earth below it or not; for example, the decrease in gravity for motion from Lat.  $50^\circ$  to Lat.  $45^\circ$  is equivalent to a change of pressure of nearly 0.5 mb.

Then, again, any wide departure from isostatic equilibrium, such as is suggested by this research over the Indian Ocean, may show itself over

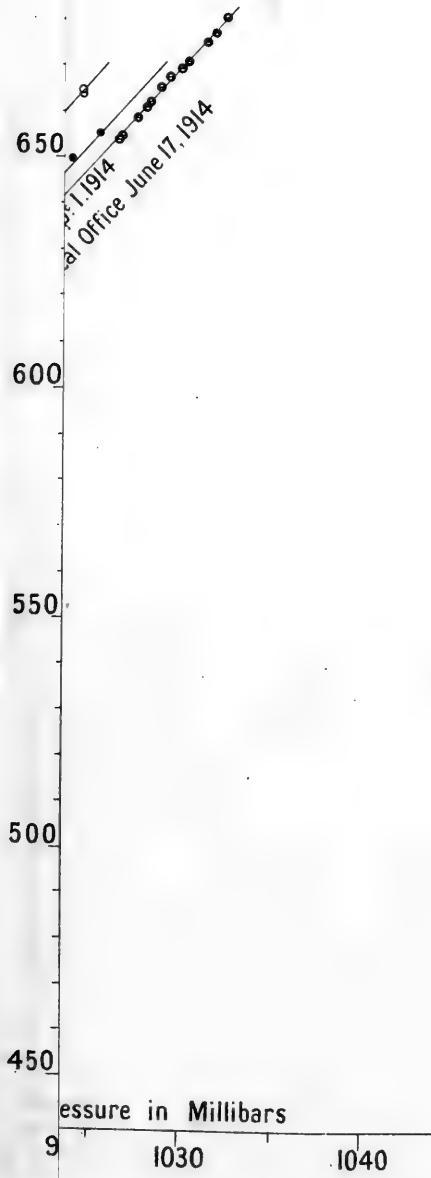

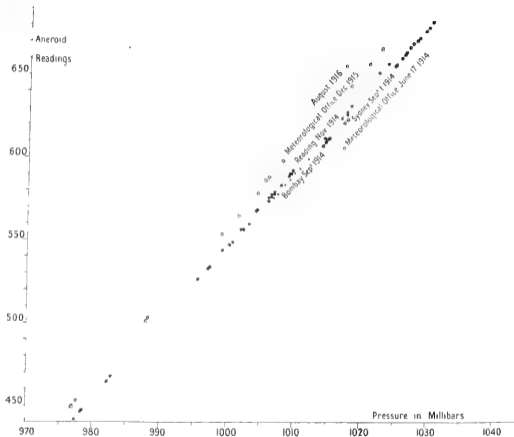

Illustrating the Report on the Determination of Gravity at Sea.

FIG. 2



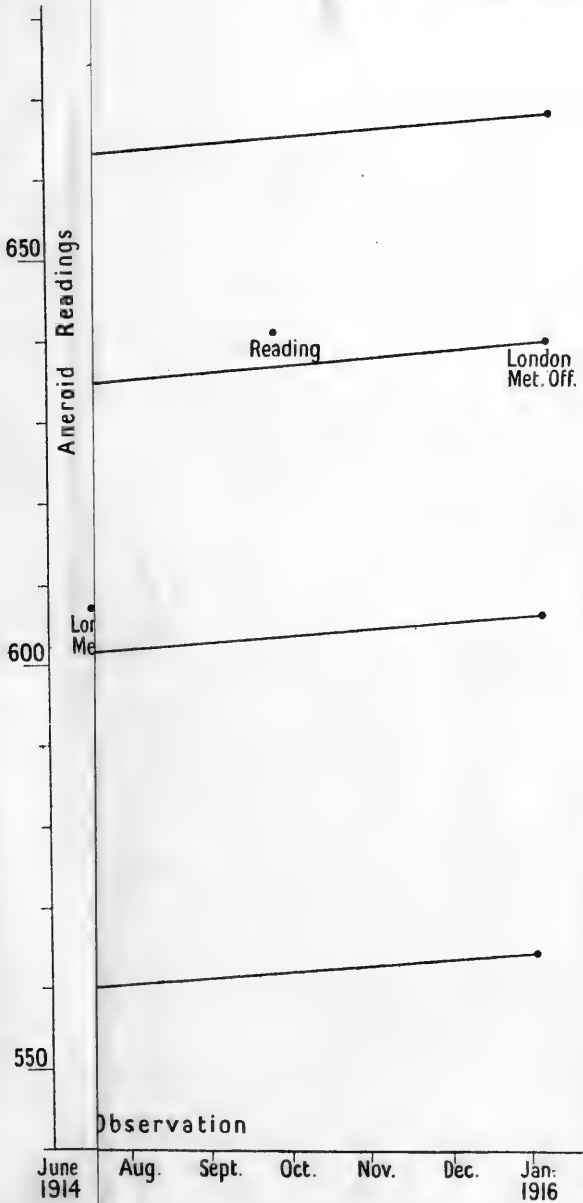

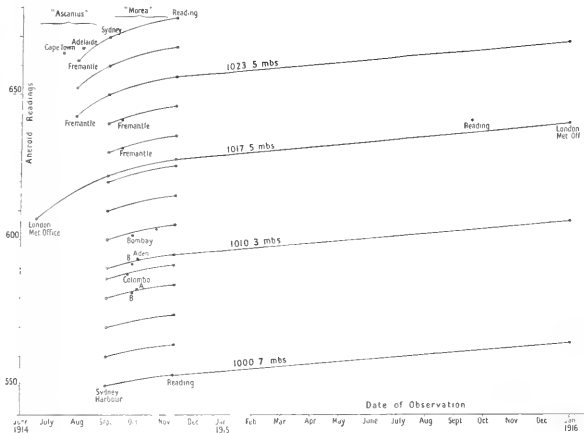

Illustrating the Report on the Determination of Tendency at Sea.

FIG. 8

f  
rs  
gs  
gs

.

o

o

0 ————— 1.2 millibars

FIG. 4.

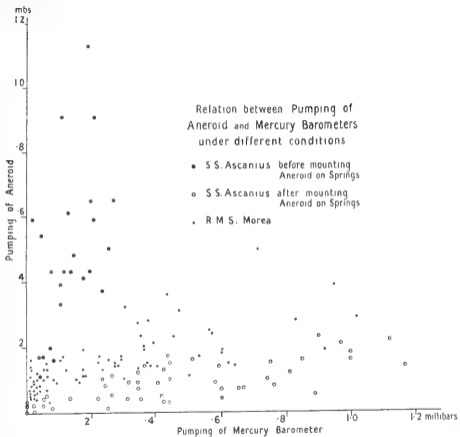

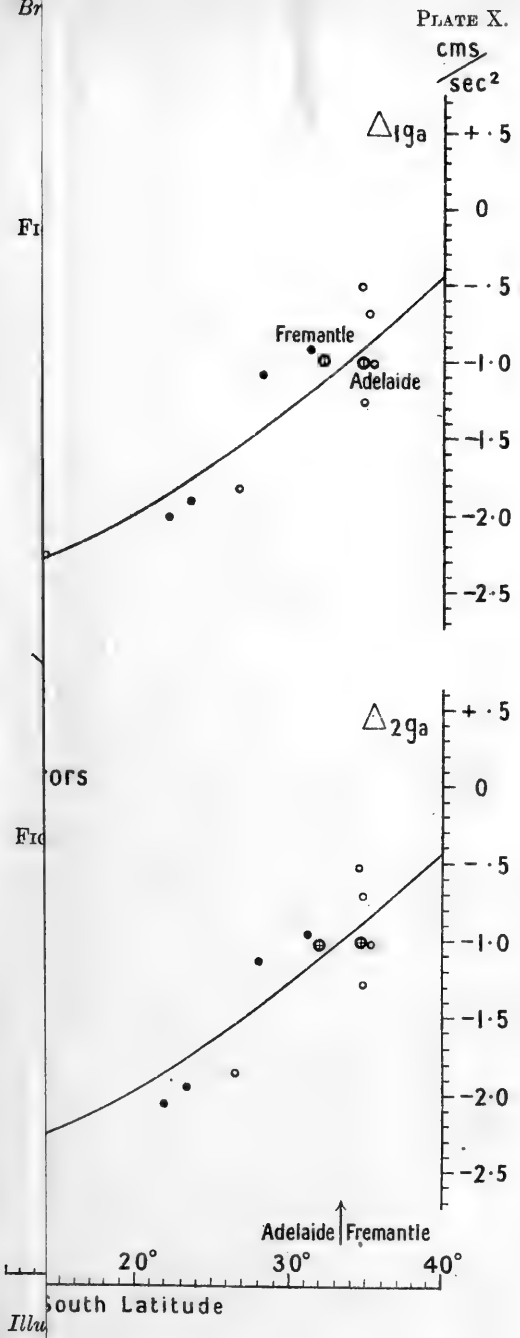

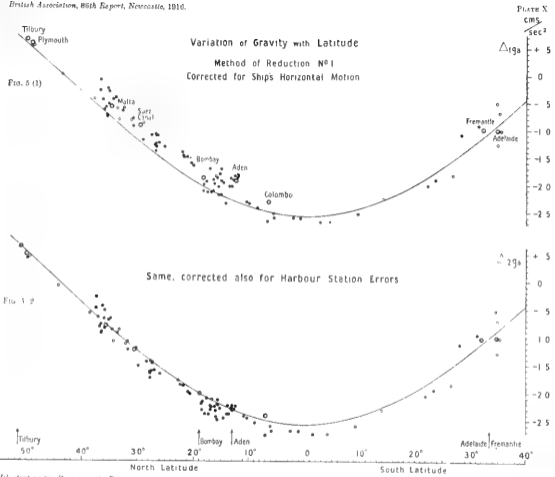

*Illustration of the Report on the Determination of Gravity at Sea*

FIGS 5 (1) and 5 (2)

cms  
sec<sup>2</sup>

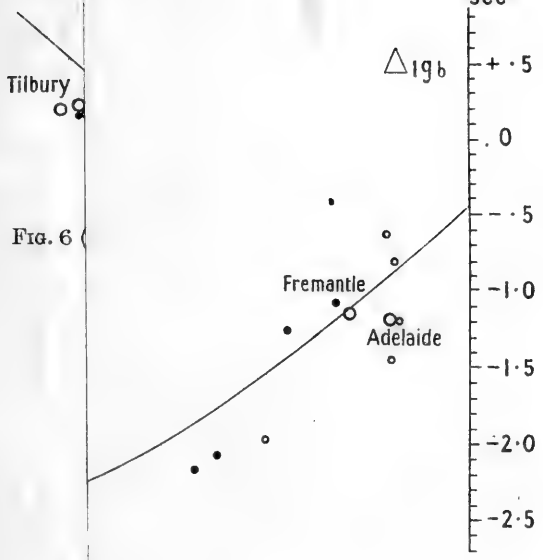

FIG. 6

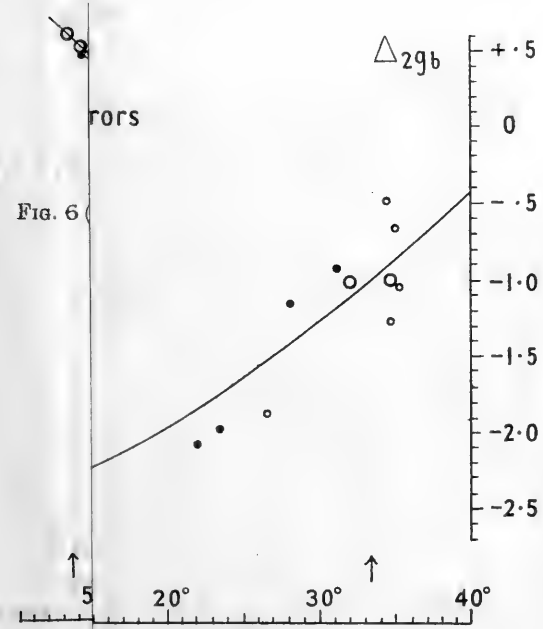
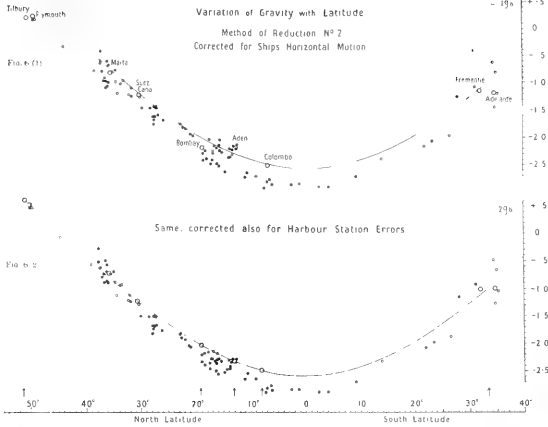

FIG. 6



Illustrating the Report on the Determination of Gravity at Sea

Figs 6 (1) and 6 (2)



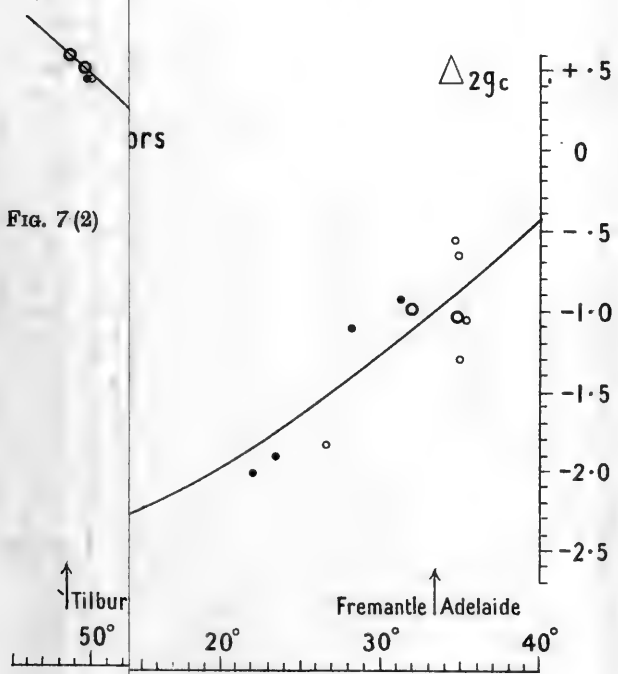
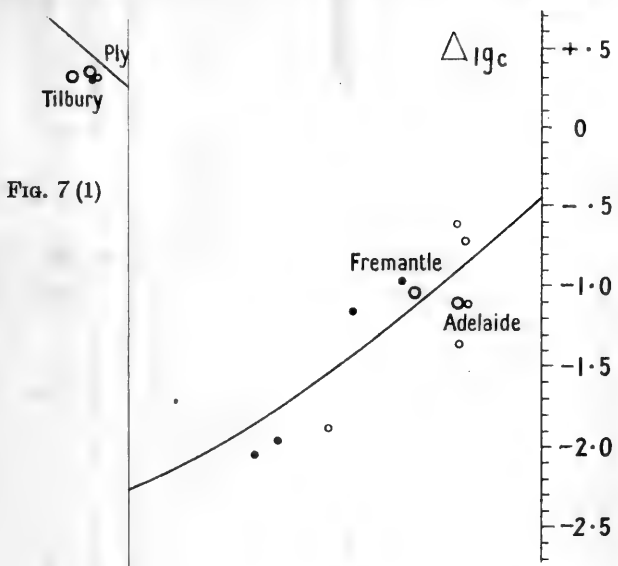



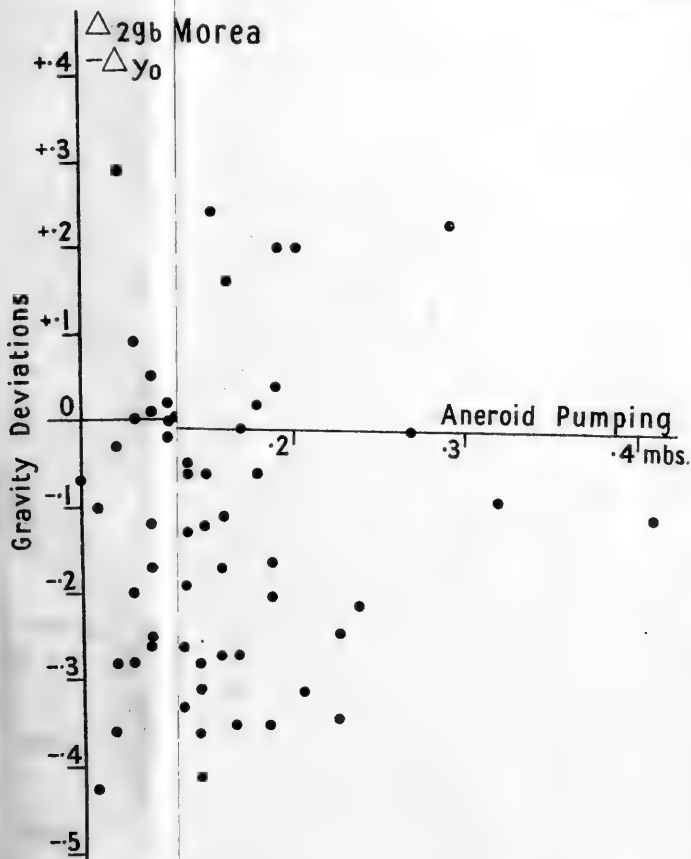

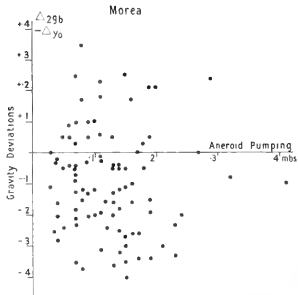
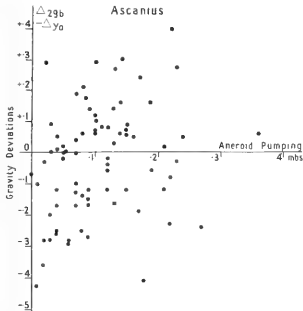

Illustrating the Report on the Determination of Gravity at Sea.

FIG. 8

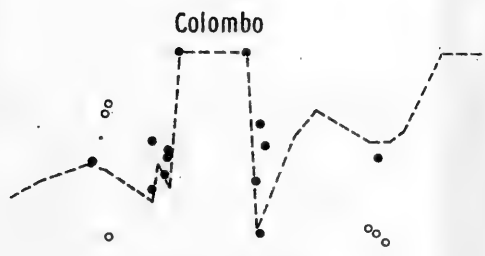
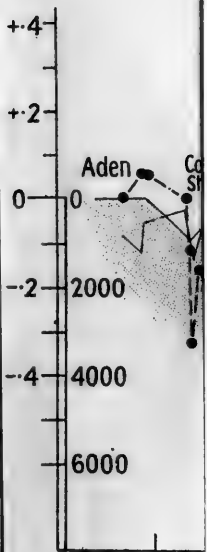
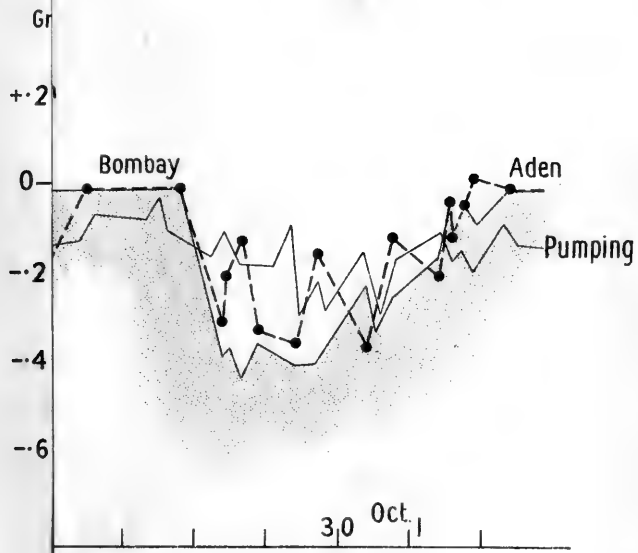

Broken Curve Aneroid Method  
 Circles Gravity Barometer Method  
 Preliminary Trial

FIG. 10.

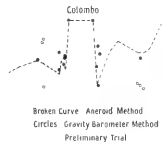
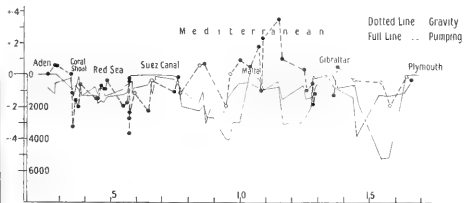
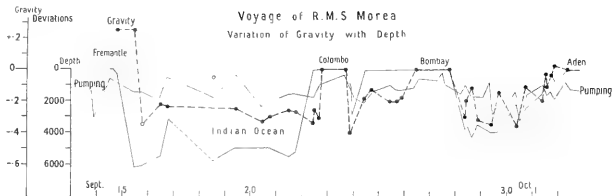

Illustrating the Report on the Determination of Gravity at Sea.

FIG. 10

PLATE XV.

•

•  
•

6000 METRES

d Depths

es

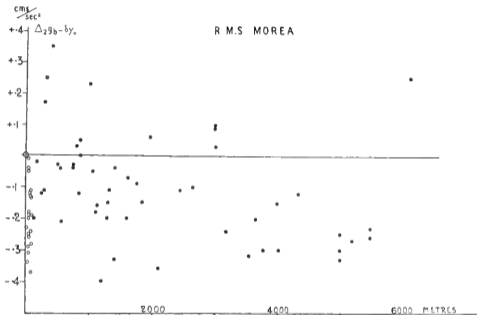

Deviations from Theoretical Value of Gravity and Depths

Open Circles represent Depths less than 100 Metres

Land and Harbour Stations omitted

*Illustrating the Report on the Determination of Gravity at Sea*



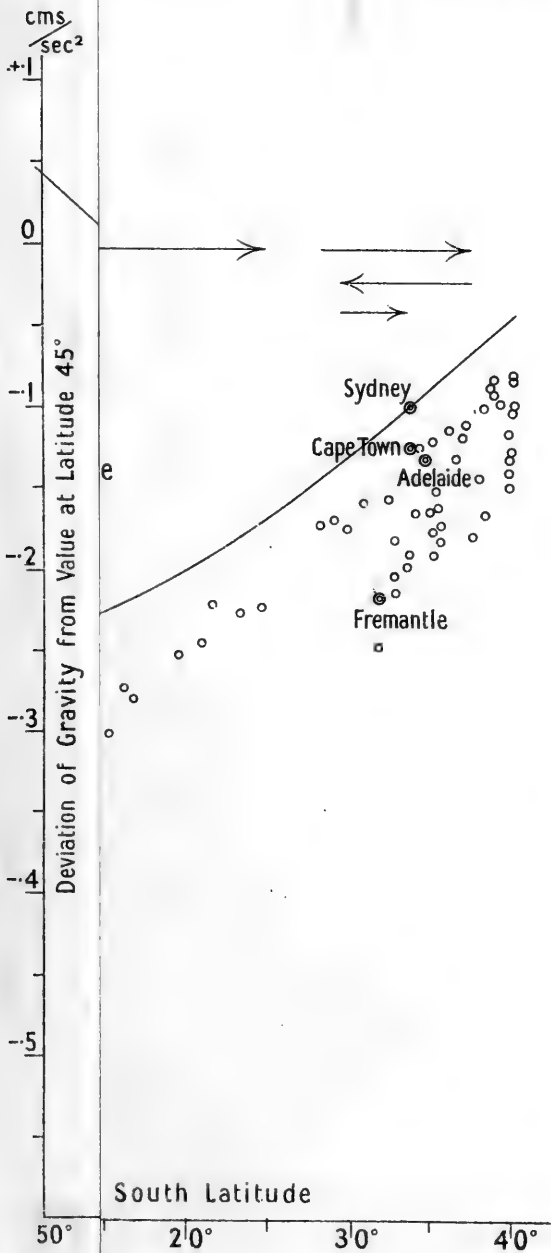

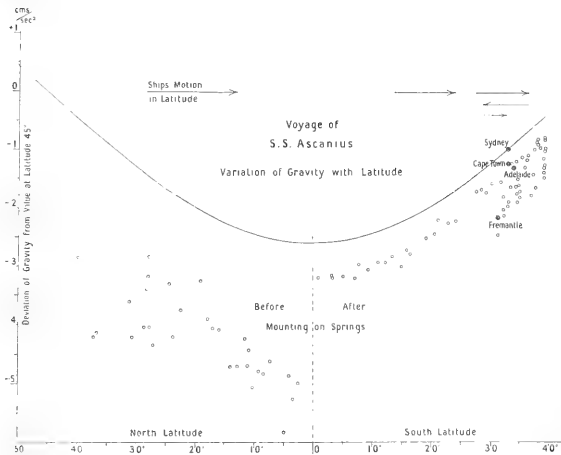

*Illustrating the Report on the Determination of Gravity at Sea.*

FIG. 12

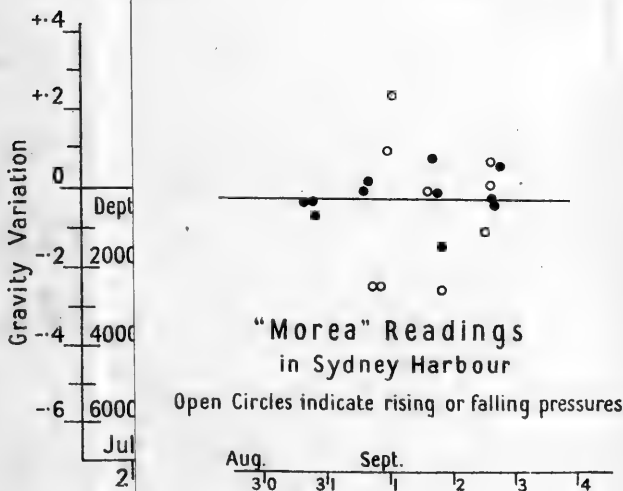
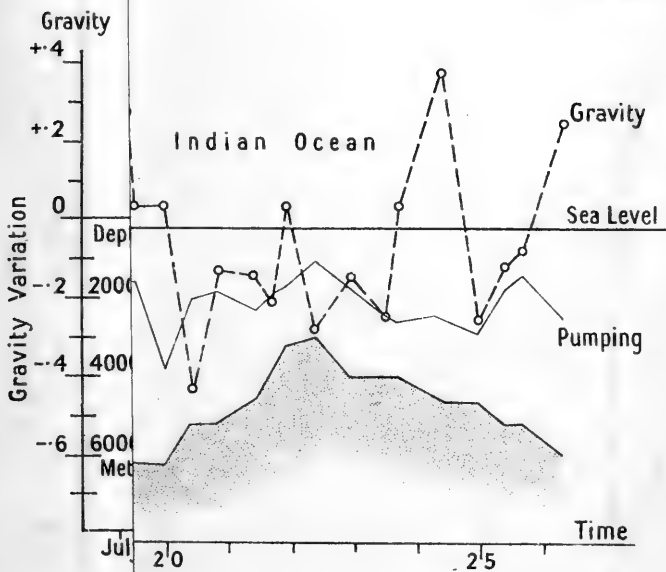

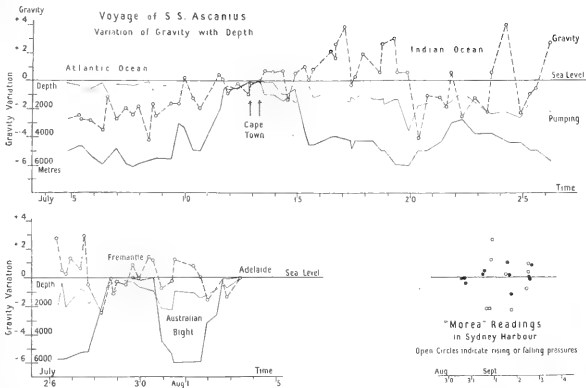

Illustrating the Reports on the Determination of Gravity at Sea.

FIG 14.

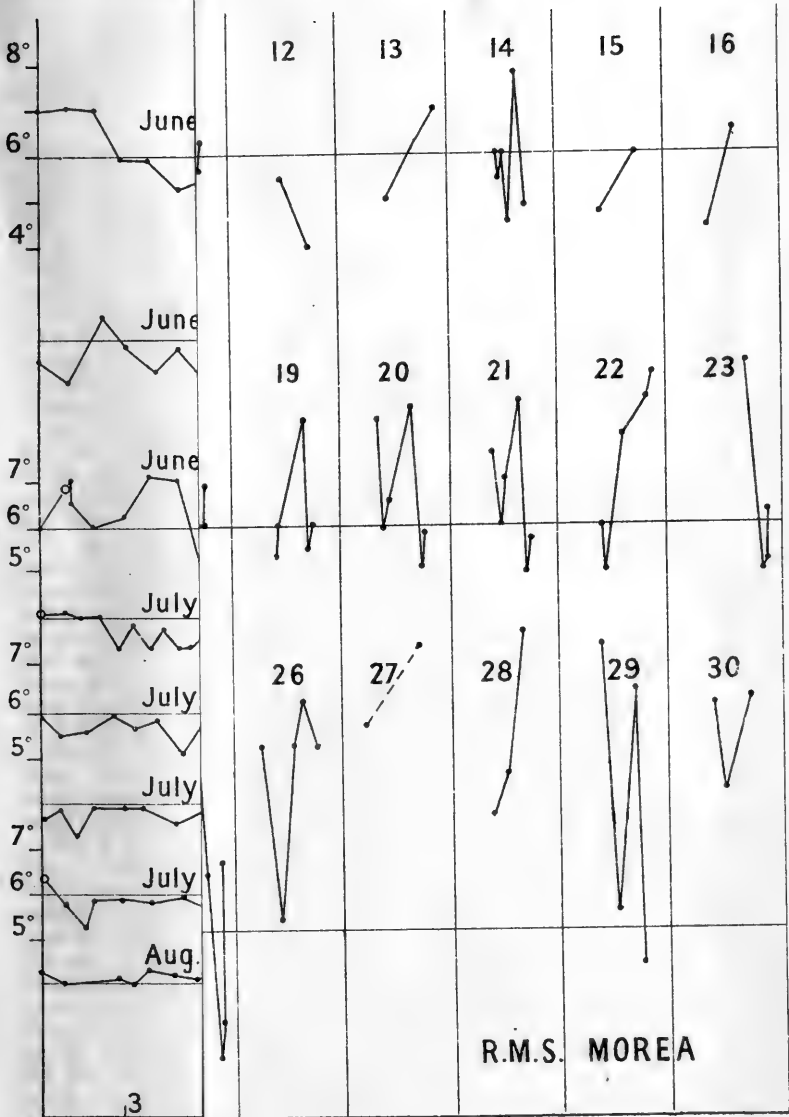

FIG. 16.

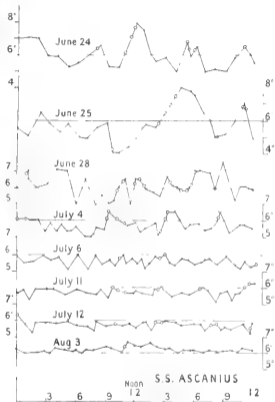
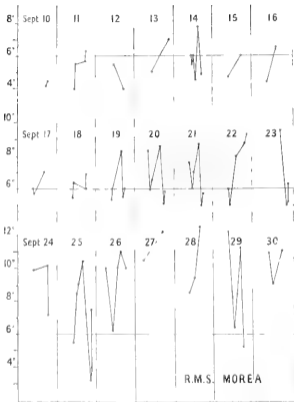

FIG. 16

Illustrating the Report on the Determination of Gravity at Sea.

Regulation  
of  
Refrigerating  
Chambers



R.M.S. MOREA

FIG. 18

a long series of observations as superposed upon other and larger effects due to temperature changes, and in the same way differences between coastal and inland gravity values might be looked for in the average yearly barometric pressures.

### 13. Conclusion.

In conclusion this paper is intended to be an examination of a particular method of measuring gravity at sea, and does not claim more than that it shows the limitations of the method. I think, however, that from these preliminary observations it may be confidently asserted that the general deviation of gravity from the theoretical value over oceans of depth of 6000 metres is not of greater order of magnitude than 0.3 cms./sec.<sup>2</sup>, i.e.  $\delta g/g \gtrsim 3 \times 10^{-4}$ . Certain divergences have been found; it cannot be definitely asserted that they are real. Nevertheless, in view of the difficulties of a research of this nature, the results have been given in some detail in the hope that subsequent researches will benefit by their discussion, and that the problem of the distribution of the material of the earth's crust may be carried a step nearer solution.

Such evidence as has been adduced points to a defect of gravity over deep oceans; there is also some evidence that there is a defect of gravity on the edge of a continental mass, especially if there is a coastal mountain range, and that gravity has higher values over island stations than over deep seas.

In the Interim Report (B. A. Report, 1915) the Committee has expressed its thanks to the Directors of the Blue Funnel and the P. & O. lines of steamships, and to the captains and officers of ss. *Ascanius* and R.M.S. *Morca*, for assistance in installing the apparatus and in arranging for the conduct of the experiments. In addition to those who have already been mentioned, the experimenter is indebted to Mr. William Haddow, officer of ss. *Ascanius*, for working out the ship's positions at the times when the observations were taken, and to Sy. Chief Officer Sandberg, of R.M.S. *Morca*, for similar services on the return voyage.

Mr. Chaundy assisted in the reduction of the preliminary observations on ss. *Ascanius*, but the bulk of the reductions on both voyages were carried out by Miss C. Mallinson, B.Sc. of University College, Reading, under the supervision of the Secretary.

Mr. F. J. W. Whipple, of the Meteorological Office, has been consulted upon a number of occasions upon points which have arisen in connection with this research, and in particular with regard to the determination of the aneroid constant; the observations made at the Meteorological Office were kindly carried out by him, and his help is gratefully acknowledged. The two barometers used in this research were made by the Cambridge Scientific Instrument Company. The marine barometer had been presented to the Meteorological Office, and it was with the Scientific Instrument Company's consent that Sir Napier Shaw kindly placed this instrument at the disposal of the writer. The aneroid was specially constructed for this research and kindly lent to the experimenter. It is with very much appreciation that the Secretary acknowledges his indebtedness to the Cambridge Scientific Instrument Company, and in particular to Mr. Horace Darwin. It was due to this generous action that a test of the aneroid method at sea was rendered possible.

## APPENDIX II.

*Corresponding Societies Committee.*—*Report of the Committee, consisting of Mr. W. WHITAKER (Chairman), Mr. WILFRED MARK WEBB (Secretary), Rev. J. O. BEVAN, Sir EDWARD BRABROOK, Sir GEORGE FORDHAM, Dr. J. G. GARSON, Principal E. H. GRIFFITHS, Dr. A. C. HADDON, Mr. T. V. HOLMES, Mr. J. HOPKINSON, Mr. A. L. LEWIS, Rev. T. R. R. STEBBING, and the PRESIDENT and GENERAL OFFICERS. (Drawn up by the Secretary.)*

THE Committee recommends that 'The Wimbledon Natural History Society' and 'The Letchworth and District Naturalists' Society' should be admitted as Associated Societies.

Professor G. A. Lebour, M.A., D.Sc., F.G.S., has been appointed President of the Conference of Delegates to be held at Newcastle, and Mr. Thomas Sheppard, M.Sc., F.S.A. (Scot.), has been appointed Vice-President.

The following subjects will be discussed at the Conference:—

1. The Encouragement of Public Interest in Science by means of Popular Lectures.
2. The Desirability of forming Federations of Societies with Cognate Aims.
3. The Importance of Kent's Cavern as a National Site.

The Committee asks to be reappointed with the addition of Sir Thomas Holland, and applies for a grant of 25*l.*

*Report of the Conference of Delegates of Corresponding Societies held at Newcastle-on-Tyne on Wednesday, September 6, and Friday, September 8.*

*President:* Professor G. A. LEBOUR, M.A., D.Sc., F.G.S.

*Vice-President:* THOMAS SHEPPARD, M.Sc., F.G.S., F.S.A. Scot.

*Secretary:* WILFRED MARK WEBB, F.L.S.

## FIRST MEETING, WEDNESDAY, SEPTEMBER 6.

The Chair was taken by Professor LEBOUR, who delivered the following Presidential Address:—

*Co-operation.*

Quite a number of our Corresponding Societies are either entirely or in part of the nature of Naturalists' Field Clubs, and it is to these that this Address is chiefly directed. The great specialised Societies of London and elsewhere to some extent conform to the spirit of the Charter of the Royal Society as expounded by De Morgan in his *Budget of Paradoxes*, viz. 'that all who are fit should be allowed to promote natural knowledge in association, from and after the time at which they are both fit and willing.' In other words, a certain amount of special knowledge is essential to membership.



No such qualification is needed before joining a Field Club. Anyone fond of Nature in any of her aspects may join freely. There is no probation. Mere interest in natural objects suffices, and I take it that the cultivation of such an interest is pre-eminently the *raison d'être* of Field Clubs. What may be called professional men of science are only accidentally members of such clubs. In the early days of these associations, when Oxford and Cambridge were the only universities in England, and did but little to popularise Natural Science, the club members were either collectors of natural objects or friends of these collectors who enjoyed sociable rambles with some reputable aim rather than solitary country walks.

The collectors who at first gathered plants, animals, or fossils merely as curiosities soon became observers as well, and afterwards all-round naturalists of an excellent if somewhat limited kind. Their friends caught the collecting ardour, learnt more or less correctly the names of many plants and animals, and acquired by actual experience some knowledge of their ways and habits. In very varied degrees each Field Club had become a group of real outdoor or practical naturalists. Inevitably small sub-groups began to develop, each devoted to some particular department—entomologists, ornithologists, conchologists, fossil-seekers, and so forth. But still, in the days I am referring to, many remained interested in all branches and truly all-round naturalists. It must be remembered that many things were then new which are now well known. A species, even of fair size, new to science, or at least new to Britain or to some county, was not the infrequent or almost impossible prize it has now become. Captures and finds such as these enheartened the members, sub-group vied with sub-group in the search for rarities, and real study of these was fostered amongst the keener and more active. In this way some became specialists or at the least local specialists. Publication naturally followed. At first, perhaps, brief accounts of excursions and presidential addresses, the latter often by local magnates wisely avoiding matters too technical. Next, lists were issued of plants, birds, or molluscs noticed during the season. These lists, as we all know, are valuable but unequally so. There is a tendency nowadays to sneer at lists—a mistaken tendency, I think. The construction of lists (good lists, I mean) entails an immense amount of labour of an arid and purely systematic kind, and requires accuracy before all things—accuracy of determination and accuracy of localities. It cannot be said to require much in the way of originality or genius, but it is necessary and useful work all the same, and work without which complete Floras or Faunas could scarcely get compiled. If such lists had been the only outcome of the Field Clubs' energies they would still have justified their existence.

But the clubs did much more. They all of them probably, at one period or another, have been the means of encouraging and fixing the scientific bent of minds which without their help would have been lost to science. I refer specially to those many remarkable men who, without special training, often without any but the slightest elementary education, have done so much towards the advancement of Biology and Geology. Every district has produced excellent naturalists of this type, and in most cases their success has been greatly due to the opportunities given by local Field Clubs. To take as an instance the region in which this meeting is being held, it may be said that without the old-established Tyneside Field Club the names of Thomas Atthey, Albany and John Hancock, George Tate—to mention a few only—would in all probability never have been known. Clubs like these gave the requisite assistance to young men of sagacity and intuition, and started them on a career of fruitful observation and discovery.

I am anxious to claim the utmost credit in the past for Field Clubs in the performance of functions such as these. The question now arises: are these functions performed with equally good results at the present time? I think that anyone who has had long and practical acquaintance with the working of such associations will, on consideration, answer this question in the negative.

A turning-point in the history of local societies, and more especially of those of the Field Club character, came some forty or fifty years ago. It coincided, I firmly believe, with the great increase in the number of subjects taught to the masses of the people and with the establishment of college after college and

university after university in every part of the country. We are here concerned with the scientific results of the new order of things. One of these results was a marked—though some will think by no means sufficiently marked—increase in the number of young men trained in the principles of science and practised in some branch of it. This was all to the good. A class of potential workers in science had come into being. At the same time, however, a still larger class had been turned into the world with what may not unjustly be termed a smatter of science. It need not be insisted on that the smatterers were not by any means always the less noisy, the less self-assertive, or the less pretentious of these two sets of men. It could scarcely be otherwise.

What was the effect of this change on the provincial Field Clubs? The newly created class of workers were soon busy at their professional labours—too busy for the most part to become active members of the clubs. The smatterers on the other hand either joined the clubs in a condescending manner or thought themselves too good for them. The influence of this on the clubs was a curious one. The old genuine Field Club naturalist was no smatterer. What he knew he knew well, from personal observation and from hard private reading, carried on often at great sacrifice, for the love of Nature and knowledge. The new smatterers were not to his taste; their long words and arrogance drove him to silence and spoil for him the old feeling of club brotherhood and equality as learners and seekers of the less academic days of the past. His modesty produced diffidence. Only the more sturdy and independent members resisted and went on as before. The others gradually dropped off. The character of the club had sensibly changed.

Again, in the course of years all the flowers, beetles, butterflies, birds, and beasts of a limited tract of country have practically been gathered. The lists of all the larger objects are complete or nearly so. Only on the luckiest occasion can even a new variety be found. Hence the purposes which actuated the eager searchers of the past are much diminished in force. Only microscopic organisms are left to be sought for. These hitherto unpopular creatures represent almost the only remaining quarry, and their search is often difficult, and needs study and patient application, together with the use of instruments beyond the reach of many. Research of this kind is undoubtedly going on, but it must remain in the hands of the few, and these few soon merge into experts and specialists and find their way into one or other of the learned bodies dealing with the subjects of their predilection. They cease to be general naturalists of the old Field Club type.

A third cause of change in the constitution and outlook of our Field Clubs is one which has been effective for a long time. The distance from the metropolis, which formerly kept outlying groups of naturalists together, has largely disappeared with the ease and cheapness of modern means of communication. The old insularity of places far from town was an asset as regards the solidarity of their scientifically inclined dwellers. This insularity has broken down. A Fellow of one of the great London societies, though he reside at Penzance or Newcastle, can occasionally attend meetings at Burlington House and listen to or even read papers there and meet leaders of science whose names alone were formerly known to him. This state of things is no doubt a gain to many a worker in the provinces, but it is far from favourable to the Field Clubs as they used to be.

I have now enumerated and briefly commented on some of the chief factors which, in the past half-century or so, have, as it seems to me, been active in the evolution of the Field Club type of scientific society. The Field Clubs are no longer quite what they were. In some respects they have improved, in others they have deteriorated. On the whole they are perhaps more scientific than they used to be. I think they produce rather less original work properly so called. They perhaps contain more well-known scientific names in their lists of members, but a smaller number of their members remind one of the enthusiastic, self-taught, coadjutant crowds of the past. They are less popular in the best sense of that word. Evolution, here as elsewhere, has been of two kinds—both progressive and retrogressive.

If it be admitted that I am in any way right in the views I have endeavoured to lay before you, we may now proceed to consider whether some means can be

found by which to make the most of the progress and to check or remedy the decadence which has set in. It is pleasing to note that already methods have been adopted by several of our societies admirably calculated to do good in the right directions. I wish to avoid invidious distinctions, but, as an instance, the system of fruitful and promising co-operation amongst local societies in Yorkshire, so capably conducted by our indefatigable Vice-President, Mr. Sheppard, may be referred to without fear of criticism.

In some form of Co-operation I believe the remedy to be sought for lies. That word in the present connection is, to my mind, preferable to Federation. Federation connotes a certain amount of subordination of the federated units to the Union. Subordination, however useful, economical, and wholesome, is normally hateful to bodies of the local Field Club kind. The smaller the State the greater its devotion to Liberty. Co-operation, on the other hand, if of the very mild nature which it is my object to suggest, would, I think, much increase the total value of the work done by the smaller societies, satisfy their sense of autonomy, which is always strong, and would provide incentives for carrying out actual observational work by even the least of their members.

The kind of co-operation advocated, as it must necessarily vary in particulars according to the subject dealt with, will be best understood if I limit myself to explaining its proposed mode of action in connection with Geology—the only branch of science with regard to which I can claim any right to speak.

The sort of geological work which members of Field Clubs can be supposed to undertake is by no means inconsiderable, but a great deal of what is done as things stand at present is lost either altogether, or lost for the time being, and, like a post-dated cheque, cannot be made use of when it is most wanted. It consists (*a*) of long-continued observations having a definite object in view, the final results of which may provide the materials for a memoir of some importance; or (*b*) of a number of disconnected records with no one leading object in view to which short notes will do full justice [N.B.—Short notes, often containing information of the very first importance, are time after time buried in hidden corners of obscure Transactions and Proceedings, and thus lie *perdu* often for years. They are amongst the worst features, in one sense, of out-of-the-way local publications]; or (*c*) of mere collections, both useful and useless, palæontological or petrological, made according to some sensible plan or not, and which may or may not comprise contributions to science worthy of permanent notice.

Under (*a*) many important subjects of investigation may be cited; for instance, the detailed mapping of stratigraphical subdivisions too small or too poorly defined to be included in maps of the Geological Survey. A great deal of excellent work of this sort is possible which, while primarily of local value, may become of more general interest and utility if it be carried on simultaneously in adjoining areas by members of neighbouring clubs.

Or, if the region have a coast-line, a systematic record of the changes caused by frost, wind, rain, and tide along it, as they take place, carefully kept and entered periodically—say every five or ten years—in some form agreed upon in common with several other sea-board clubs, must, as the years roll on, become of national importance. The lack of such information was strongly impressed upon me when, a few years ago, I was asked to gather together all the evidence required by the late Government Inquiry on Coast Erosion relating to the shore between Tees and Tweed. The authoritative evidence was scrappy in the extreme, and landslips, which, by their disastrous effects must have created much local interest and excitement at the time of their occurrence, were frequently found to be without history of any kind or else reported by contemporaries in a manifestly exaggerated or fabulous manner.

All clubs have rivers, large or small, within their purview. Very few of these rivers, however, are watched day by day or even season by season by careful geological eyes. Yet there is much to be observed in connection with them. The wasting of their banks, the variations in their channels, the rate of their flow in their successive reaches, the constantly changing nature and quantity of the sediments which they carry, the causes and effects of their spates, to say nothing of the chemical examination of their waters—these are all good subjects for investigation by club members living on their banks. One

club may undertake the work in one portion of the river and another above or below, as the case may be. The joint tabulated results, on a pre-arranged and carefully considered system, would be of permanent value.

Again, as regards Fossils. Now that zoning has become so much the fashion, the recognition of zones in adjoining areas by means of preconcerted simultaneous collecting in the same beds may lead to far-reaching generalisations. In a comparatively short time the value of a zone or supposed zone may be determined. It may be shown to be a case of mere local distribution, or it may prove to be of vast extent and become a stratigraphical landmark of great utility. In this connection I would especially like to call attention to the case of strata in which occur coal-seams, oil-shales, ironstones, and other deposits of industrial interest. The recent work of many competent geologists has shown the great value that may attach to certain beds charged with special plant-remains, fish and shell-bands, algal layers, and other horizon-fixing organisms in such rocks. Such things have been noticed for years by isolated observers, very few of whom have troubled to make their occurrence generally known. Lately the continuity of some of these fossil horizons over large areas has at last been recognised, and the great value of some of them in fixing the position of workable beds of one kind or another has been abundantly proved. But there is room for much more intelligently-conducted research in this field, and especially for much more rapidly acquired knowledge of this sort. Let every Field Club fossil-collector in our coalfields record his finds of such fossil 'indicators'—if I may so call them; let his records be properly combined with those of every other club similarly situated, and it will not be long before a really authoritative schedule can be drawn up in which every such 'indicator' is placed in its proper relative position in the column of strata and its horizontal extension, upon which its practical utility largely depends, is correctly shown. Some of these zones will be then known as of great value, others as of less constancy, and some will be discarded as too uncertain for use in practice, though they may retain much interest from the purely scientific point of view.

As regards Glacial Deposits something has already been done in the way of co-operation, and that too very successfully. Boulder committees exist in connection with several societies, and some have combined their results. I should like to see such committees multiplied, and the results of all sifted and tabulated on some well-thought-out system, so that all the vast amount of work they represent may become readily accessible and ultimately bear fruit.

In the collection of Borings and Sinkings also a good deal has been effected by costly publications issued by some of the great mining institutes, and by the invaluable well-sinking records so carefully preserved for us by our past-President, Mr. Whitaker. But there is no end to this form of work, and all our societies, if they are willing to co-operate, can take part in it with great advantage.

The above are some only of very many directions in which the clubs and societies, working on pre-arranged lines with each other, may, in the field of our branch of science alone, induce their individual members to take part in wide-reaching research with the certainty that no bit of work, however small, will, so long as it is honestly and carefully done, be lost (as it now is nine times out of ten), but will find its place as a stone in some worthy edifice erected by the joint efforts of many others. Co-operation of the sort I have in my mind should be so planned that the maximum value in useful results will be obtained from the maximum number of co-workers. The enormous saving of time to be arrived at by such methods will be patent to all. The use at last found for odd notes and notelets, the reduction of size in publications, with the saving of money which follows—these are some of the points I rely on in submitting my suggestions to the consideration of our delegates. The machinery to carry out such schemes must be left to those in whose hands lies the management of the different societies if they should think any of them worth trying. This brings me to my last suggestion. It is that the co-operation I mean could probably be made practically effective by the delegates themselves acting as plenipotentiaries in special assembly for the purpose during the annual meetings of the British Association.

In conclusion I wish to say that I regard the views I have expressed as in

no sense opposed to those of my predecessor in this chair, Sir Thomas Hollaud, whose proposals could, one and all, be adopted concurrently with mine, as, indeed, I trust they some day may be.

Sir EDWARD BRABROOK (Balham and District Antiquarian and Natural History Society) proposed a vote of thanks to the President, whose Address had shown conclusively the value which attached to Conferences such as these. With regard to the first question which was about to be discussed, he asked leave to explain that the Report which had been laid upon the table was that of a Committee of the Council of the Association appointed to consider the subject of Popular Scientific Lectures, and was, in fact, an interim report awaiting further consideration by that Committee. It mainly consisted of a valuable digest, prepared by Professor Gregory at the Committee's request, of the answers received by the Committee to their inquiries; but it also contained certain recommendations, with which the speaker himself entirely concurred, but for which the Committee as a body were not responsible, and, as these were at present without official sanction, their free discussion by the Conference would be welcome and desirable.

The Rev. T. R. R. STEBBING (Tunbridge Wells Natural History and Philosophical Society), in seconding the vote, said: Our President is so sensible of the value of time that the rapid delivery of his Address has left my slow-working mind unable to grasp at once all the valuable suggestions he has been offering, or even to formulate the compliments you would wish me to offer him in return. On one point I venture to make a remark. The faunistic lists drawn up without expert knowledge may introduce many errors in regard to distribution. For this reason I myself in presenting such a list endeavour to supplement it with some information which may enable other students to test my trustworthiness. The President gives a valuable warning against the publishing, or, rather, concealing of important facts in obscure Reports. Much time, also, is wasted by the inadequate description of species which celebrated naturalists of old often thought sufficient; moreover, rising naturalists in the present do not always recognise the increasing need for full illustration by pen and pencil.

The first subject for discussion was 'The Encouragement of Public Interest in Science by Means of Popular Lectures.' The Corresponding Societies Committee had introduced it at the request of the Council of the British Association, the reason being that the special Committee, with Professor R. A. Gregory as Secretary, mentioned by Sir Edward Brabrook, had been brought into existence to consider the matter.

The following paper was read by Mr. PERCIVAL J. ASHTON, Extension Lecture Secretary of the Selborne Society:—

### *The Encouragement of Public Interest in Science by means of Popular Lectures.*

It has been recently said that much less attention is now given to popular lectures than was formerly the case; and if such be the fact, then it is highly desirable, at a time when the need for educating the public in science is manifest, that the scientific societies should bestir themselves in this matter.

The report of the Committee appointed by the British Association to investigate this question will show whether the above statement is correct, and it is to be hoped that it will give much valuable information thereon. Whatever the consensus of opinion may be as to the relative importance given in the past and at present to the spread of popular scientific education, it is incontestable that the most pronounced effort of the past would be inadequate to deal with the vast opportunities of the future.

Science must play an all-important rôle, both during and after the war, and the scientific societies will have to deal with the problem in a broad, enlightened manner, and make a determined effort to instil into the minds of the people the need of a sound scientific training, treating science in its broadest aspect, and applying the tenets of scientific thought to the various ramifications of trade and industry.

We are concerned here with a discussion as to what the scientific societies are able to do in this matter. The problem must be approached carefully and with discrimination. Some societies may find that their organisation enables them to work out their destinies by themselves; others may require considerable help; others, again, are in a position to give the help required.

I conceive that to obtain a proper estimate of the value of the meetings of a scientific society their objects must be clearly grouped into two main divisions: (a) They should be the ways of educating the people in scientific thought, presenting by means of lectures or other activities the fundamental principles and modern achievements of science in a manner which will at once arouse an interest and enthusiasm amongst beginners; (b) they should endeavour to promote and record all local activities in the various branches of thought. Without a due regard for the first object, talent will remain hidden, and the second object becomes difficult or even impossible to attain.

The difficulties to be met with in seeking an improvement upon the present system are principally three in number: (1) The objects of many societies are so framed by their rules as to limit their activities to local pursuits and debar them from taking up their proper rôle as popular educators; (2) where attempts are made to remedy the defect, too much reliance is often placed on amateur lecturers (do not mistake my meaning; a man may be the most learned scientist of his day, but the merest tyro as a popular lecturer), and well-meant efforts lose much of their value by the imperfect or unattractive manner in which the remarks are delivered. Versed in technical lore, a lecturer often forgets that his audience can only understand difficult problems when explained in simple language and well illustrated by lantern-slides or experiments. As a means of recording local activities this criticism does not apply to the same extent, though I suggest that research work loses some of its value by being inadequately explained; (3) the inability of the society to call in the aid of a professional lecturer by reason of lack of funds. These difficulties are probably applicable to many societies represented at this meeting.

There is, further, to be combated the criticism, often made against a professional lecturer, that he is not always scientifically accurate. If he has had a careful scientific training he should be strictly accurate; and if he understands his business he should deal with technical points in a clear and simple manner, and should realise that his audience want to be interested, and not to be compelled to listen to facts which do not appeal to them.

Such being the difficulties which had to be contended with, the Selborne Society endeavoured to found a scheme which would assist local societies in securing competent popular lecturers, and I would ask the indulgence of this meeting in briefly explaining the steps taken. For some years the Manchester Microscopical Society have organised an Extension Section by which their members are available to lecture to neighbouring societies; and, taking this scheme as a basis for investigation, it was decided that a similar scheme would only be possible if material changes in the proposals were made; for we desired to offer the services of our lecturers to any town in the United Kingdom. Apart from other considerations, lack of funds necessitated the employment of professional lecturers.

Accordingly, we have secured the services of some forty lecturers on natural history and antiquarian topics, all of whom have had considerable experience in lecturing, and synopses of their lectures have been set forth in a published handbook, which is circulated amongst various societies and schools. The scheme was inaugurated at an unfortunate time, *i.e.*, just prior to the outbreak of war; but, despite the most adverse conditions, it has in a limited way proved most successful. Experience has shown that there is a great demand for lecturers who are willing to accept moderate fees, but who have the ability to deal with their subject in an adequate manner.

There have been difficulties in getting in touch with the most suitable societies in connection with these lectures, whilst in many cases societies have written to say that, the non-professional character of their meetings having become established, the present time has naturally not been chosen to make a new departure. It is, further, essential that if the societies of moderate means are to avail themselves of professional lecturers, the visits must be arranged in

the way of organised tours. I will take a case in point. Until certain of the societies temporarily suspended their meetings, we were able to send our lecturers on successive evenings to societies at Teignmouth, Liskeard, Launceston, Exeter, Taunton, and Bridgwater, and in each of these cases lecturers were secured at fees which would otherwise have been impossible.

The scheme is at present undeveloped in certain directions, and I would mention that we intend to broaden its scope and include more physics and chemistry, as well as science as applied to the home and to various industries. We should naturally welcome any suggestions towards an improvement of these efforts, and at the same time should be pleased to be of assistance to local societies.

In conclusion, I suggest, as the basis of discussion, certain concrete steps which could be taken to carry out the needed changes:—

1. The objects of the various societies should be carefully scrutinised to see whether any alterations in the rules are necessary in order to widen the scope of their activities.

2. A central bureau for the supply of lecturers should be established in order that professional or other competent lecturers could be at the service of the societies, regulating their visits in a manner which would compensate them for their services, and be within the financial scope of the societies.

3. Where the funds of the society will not permit of direct payment of fees, the difficulty of raising the necessary expenses can be overcome by dividing the meetings into two classes: (a) special members' evenings for discussion of local or advanced topics; (b) popular evenings, to which a charge for admission could be made, and the public admitted. This method has been adopted with success in many societies, including, recently, the Selborne Society. Our subscription (five shillings per annum) being manifestly inadequate to meet the expenses of professional lecturers and guides, the lectures and rambles have been subdivided, the members' excursions, under voluntary guidance, being continued side by side with a new series of public rambles and lectures under professional leadership.

Since preparing this paper I have, by the courtesy of Professor Gregory, been able carefully to read the report of his Committee, and as the same is now placed before you I would offer a few criticisms on the suggested recommendation, for I observe that by paragraph 7 of the 'Recommendations' suggestions are invited.

The recommendations are as follows:—

(1) That an annual list of public lecturers on science subjects be prepared and published, with titles of their lectures. No fees should be mentioned in the list, but addresses should be given so that committees organising lectures may make their own arrangements with lecturers. Local scientific societies, museums, and institutions of higher education should be invited to send the names of members of their bodies prepared to deliver lectures to similar bodies elsewhere without fee other than travelling expenses, and the names of such voluntary lecturers should be indicated in the list by a distinguishing mark.

(2) That committees organising public science lectures should include representatives of as many interests as possible, such as Municipal Corporations, Trades Councils, Co-operative Societies, Religious Bodies, University Extension Committees, Chambers of Commerce, Educational Institutions, local Scientific Societies, and like organisations concerned with the daily work and intellectual life of the district.

(3) That to extend interest in science, and belief in its influence, beyond the narrow circle of serious students, increased use of the bioscope in illustrating natural objects, scenes, and phenomena is desirable; and an appeal should be made to the interests of all classes of the community by addresses intended to show the relation of science and scientific method to national life and modern development.

(4) That to carry on the propaganda of efficiency through science, local committees should endeavour to secure financial support from manufacturers and others affected by national progress, and that local educational authorities be asked to provide funds to enable free popular lectures of a descriptive kind.

for children as well as for adults, to be well advertised and for reasonable fees to be paid for lecturers and their illustrations.

(5) That more encouragement should be given at University institutions and training colleges to the art of exposition and public speaking for the benefit of those students and teachers whose aptitudes may later be usefully exercised in promoting interest in science.

(6) That, while the training of an adequate number of scientific workers is of prime importance, it is desirable that everyone should be made acquainted with the broad outlines of natural science while at school, and that public appreciation of scientific knowledge as an essential factor of modern progress should afterwards be created and fostered by means of popular lectures.

(7) That this report be brought under the notice of each Section of the Association with the object of obtaining suggestions upon which organised action may be taken in connection with the Gilchrist Trust or independently.

(8) That the Committee be reappointed as a Committee of Section L, its constitution remaining, as at present, representative of all the Sections of the Association, but with power to add to its numbers.

The suggestions framed by Professor Gregory are admirable, and contain much valuable information, but I respectfully disagree with them in certain directions :—

(1) I doubt very much whether the proposed list of lecturers will be adequately utilised by the societies, for if the list be confined to merely the names and addresses of the lecturers and the titles of the lectures which they offer, there is very little on which the society could base its conclusions as to whether the lecturer is suitable or not. Every society has different conditions to contend with, and only an intermediary between the society and the lecturer can judge of the suitability of the lecture. The lecturer himself, when approached, will naturally express himself as able to meet its requirements. Such lists have been prepared by certain federations (including one of the Corresponding Societies), but, I believe, with varying success.

(2) A list in which is inserted the name of any lecturer so submitted does not carry with it any weight of authority. To be really valuable the list must only specify the lectures and lecturers passed as suitable by a recognised body.

(3) The proposed classification of the list into professional and voluntary lecturers is an excellent one, but somewhat difficult of application. Many lecturers frequently lecture voluntarily under special circumstances, but their names would not be placed on the voluntary list, and by describing them specifically as professional lecturers their services are lost to a struggling society.

(4) Not only scientific societies and similar institutions should have the benefit of such proposals as are finally agreed upon, but these should be communicated to public and private schools, as well as lecture-societies. Schools can, however, generally pay fees, and by arranging for a lecture at a school in the afternoon and before a society in the evening, both organisations benefit. My previous comments as to touring arrangements are aptly illustrated in this connection.

(5) The recommendations as to the extended use of the bioscope are admirable, but some of you will probably instance numerous difficulties in the way of carrying out the proposals. Certain cinema-theatres have arranged for cinema lectures, and greater co-operation between the cinema and the lecturing profession is essential. The Selborne Society has had such co-operation in view for some time, and we hope shortly to have definite proposals to submit.

The above criticisms are put forward as the basis of a discussion which, I hope, will contain that critical analysis essential to all constructive proposals.

A discussion then took place.

Professor R. A. GREGORY said : I desire to state here that the report on popular science lectures to which Mr. Ashton has referred is an interim report, and that the recommendations are of the nature of suggestions rather than definite conclusions for immediate action. The Committee realises the difficulties involved in the preparation of a list of lecturers, and would welcome any practical assistance which scientific societies may be able to give in connection with such a list. Many societies have suggested that a list should



be compiled by the Association, and the suggestion made in the report indicates one way of helping them. The difficulty as to paid and voluntary lecturers is no doubt real, but it is not impossible to find a working plan to overcome it. As to the qualifications of lecturers, probably the best plan would be to give with the name of each lecturer the name of the society responsible for its admission to the list. Societies and committees would soon learn upon whose nominations they could depend for good lecturers. What is wanted also is lecturers who are advocates rather than scientific investigators, who will carry on propaganda work, showing that science and scientific method are essential to modern life and national existence.

The Committee has been reappointed by the Council, and it is hoped that by the next meeting a practical scheme will be ready.

Mr. MARK L. SYKES (Manchester Microscopical Society) pointed out that about twenty-one years since he suggested to the Manchester Microscopical Society the formation of a section<sup>1</sup> for the purpose of extending its work by giving to outside societies lectures and addresses on microscopical and biological subjects and demonstrations in practical microscopy by members of the Society who were known to be qualified for the work by both knowledge of their subjects and ability to impart it in an interesting and intelligent manner. A committee was appointed and the extension section established, its objects being the extension of the knowledge of microscopy and natural history to outside associations, by means of lectures and demonstrations. A list of lectures and demonstrations was printed and distributed to the secretaries of other societies, kindred, literary, co-operative, political, and others, and to a number of schools in the neighbourhood of Manchester, and in Lancashire and Cheshire generally. The movement has been a success from its commencement, demonstrations in mounting, manipulation, light, optics, and other branches of microscopy being given, and a fairly wide range of subjects lectured upon, chiefly in relation to the main objects for which the Microscopical Society was founded.

The work done is entirely voluntary on the part of the members, it not being the intention of the Society to compete with the professional lecturer. Fees are, in some instances, asked for from societies who can afford to pay them, but these go to the funds of the Microscopical Society, and are devoted to the purchase of apparatus, lantern slides for lectures, and similar objects, but in some cases not even expenses have been charged. The object has been solely to advance interest in science and natural history by means at the Society's disposal, care being taken that only lecturers qualified for the work shall be admitted to the lecture list.

The Manchester Microscopical Society welcomes any extension of the movement, feeling that the work done in the past has been justified by its results, and any assistance which can be given will be rendered with pleasure.

Mr. THOMAS SHEPPARD (Yorkshire Naturalists' Union and Yorkshire Philosophical Society) congratulated the Conference upon the great value of the report prepared by Professor Gregory, and sincerely hoped that something definite would be done to assure that his recommendations were carried out. Mr. Sheppard referred to the work the Yorkshire Naturalists' Union had done by its lecture scheme, in providing popular lectures each winter among the forty affiliated societies. It was, of course, obvious that after the present great crisis much will have to be done to show that science must take its proper place in the life and existence of the country. That can be largely carried out by securing properly qualified and able popular scientific lecturers.

Mr. H. SOWERBUTTS (Manchester Geographical Society) said that the tendency nowadays seemed to be for the majority of lecturers (outside the members of one's own Society) to require fees, instead of it being the exception as was formerly the case; then they seemed only too pleased to have the opportunity to speak on the subjects in which they were interested.

He also reminded the Conference that the Manchester Geographical Society formed a lecturing section of its members in 1887. The lectures were called Victorian from the year of formation, and a full account of them was given by Mr. J. Howard Reed, F.R.G.S., at the Association Meeting at Liverpool in 1896 (p. 858 of the Annual Volume).

<sup>1</sup> Mentioned in Mr. Ashton's paper.

Mr. ALFRED W. OKE (Brighton and Hove Natural History and Philosophical Society and South-Eastern Union of Scientific Societies deprecated the payment of lecturers.

Mr. WILFRED MARK WEBB (the Selborne Society) pointed out that things had changed of recent years, and that it was unfair to ask a man to do what was really part of his professional work for nothing.

The Rev. W. JOHNSON (Yorkshire Philosophical Society) reported that a larger series of lectures than ever before was being given in York, mostly without fee other than expenses. These attracted as large audiences as before.

On the general question we had to contend with the fact that all science schools were giving these lectures, covering the ground of our earlier lecturers, and so only lecturers on advanced subjects were able to attract audiences in general.

The Rev. T. R. R. STEBBING said, with reference to the payment of scientific lecturers: In *Nature* recently it was urged, as a reason why science was so little thought of in Great Britain, that so much scientific work was done without remuneration. Thoughtless persons were only too apt to apply the dictum current among lawyers that advice gratis is worth just what is paid for it.

Dr. F. A. BATHER (Museums Association) suggested that a fresh sub-committee was unnecessary. It would be simpler if delegates having proposals to make would send them to Professor Gregory, and if the actual work of organising were left in the hands of bodies already doing it so well as was the Selborne Society.

Mr. PERCIVAL J. ASHTON said, in reply, that the discussion had shown a difference of opinion among the delegates; there were (a) those who held that to secure competent lecturers fees must be paid; (b) those who considered it more in accordance with the dignity of a scientific society that the voluntary system should be maintained. For the latter a list of voluntary lecturers would be useful, for the former the Selborne Society's scheme might be welcome. Instances could be cited of the professional lecturers on the Society's staff giving voluntary lectures before scientific societies, whilst in a number of cases fees which merely covered expenses were accepted.

The remarks of Professor Gregory as to the advent of a new type of lecture were of great value, and a beginning in that direction by one of the Society's staff was instanced, and at least a professional lecture scheme in this connection could be promoted irrespectively of the vexed question above alluded to. The discussion had produced valuable criticism, and the British Association's Committee could be relied on to evolve the most suitable solution of the problem.

The Conference then adjourned.

## SECOND MEETING, FRIDAY, SEPTEMBER 8.

The Vice-President, Mr. THOMAS SHEPPARD, took the Chair, and Alderman ARTHUR BENNETT, President of the Warrington Society, read a paper entitled

### *The Federation of Cognate Societies.*

According to one of the older standard dictionaries, the word federation is derived from the Latin word *fœdus*, a league or treaty, and signifies 'the act of uniting in a league; a league; a union for purposes of government.' But, like many other words, it has gradually acquired a wider meaning, and the New English Dictionary, published in 1901, describes it as 'the action of federating or uniting in a league or covenant. Now chiefly the formation of a political unity out of a number of separate states, provinces, or colonies, so that each retains the management of its internal affairs; a similar process applied to a number of societies, &c.' In a little book I wrote in 1892, 'The Dream of an Englishman,' I ventured to define it as 'union for common purposes, liberty in matters of separate concern,' and essayed to show that, in this broader sense, it is a clue to the solution of a host of difficulties, the golden key which would unlock great doors of difficulty hitherto most obstinately closed.

In my youthful enthusiasm for the new idea, which had dawned upon me

with something of the splendour of a revelation, I tried to prove that, properly interpreted, it would not only solve the Irish question and pave the way to a really United Empire, but by gradual and easy stages lead to a series of similar federations and culminate in Tennyson's sublime ideal, 'the Parliament of man, the Federation of the world.'

But my imagination 'grew with what it fed upon,' and, 'following the Gleam,' I saw this simple principle not only uniting the nations without in any way obliterating their nationality or interfering with their own traditions and their local freedom, but gradually linking up the churches, and leading to a Christendom in which genuine unity was consistent with infinite diversity, and the church catholic was something more than a name.

A good deal of water has flowed under the Tyne bridges since those early years, but I am more convinced than ever that all these things and more may be accomplished by the right interpretation of the magic word.

Events, indeed, have justified my faith, for, since that date, we have seen the principle applied with great success in Australia and South Africa, and found men of every party feeling towards the simple truth that federation is the only way to solve the riddle of these islands consistently with the satisfaction of the claims of the various parts of them to what is popularly called Home Rule, and to organise the future of our far-flung Empire on a basis which will harmonise the interests of the King's dominions as a whole. And, to give one instance only in the realm ecclesiastical, the various Nonconformist bodies in the country have long ago drawn close together through the medium of a Free Church Council, and are rapidly advancing towards still closer union on the same elastic lines.

And the principle is so simple and so absolutely logical that it cannot fail to make increasing headway as the years go by. Why should not any group of nations, or of churches, unite in the pursuit of the things on which they are agreed, retaining their full liberty of action in the things on which they differ? And why should the principle be limited to nations, or to churches, or, indeed, be limited at all? The wisdom underlying it has percolated into ever-widening channels. Capital and Labour are largely organising on these lines; and though, even yet, not many really understand its meaning and its implications, it has, almost unconsciously, extended its increasing sway to almost every field of human activity, and its peaceful triumphs grow from day to day.

Encouraged by the rapid strides which everywhere the new idea was making, in 1905 I ventured to pursue it further in an address which I had the privilege of delivering to the members of the Warrington Literary and Philosophical Society. 'The interest in intellectual topics, if we gauge it by the average attendance at our meetings, has not,' I said, 'kept pace with the growth of the town. And it is dispersed among a dozen small societies instead of being concentrated in one really strong, and representative, and energetic body capable of drawing to its meetings all the best life of the place.' I pleaded for a 'general home, a joint committee, an interchange of meetings and amenities,' suggesting that the Old Academy, the headquarters of the Society I have the honour to represent (which set out with a similar ideal in 1898), might well become the nucleus of such a scheme, and went on to say: 'But even more important than a common meeting-place is a common policy, a principle of mutual assistance and co-operation. We want to bring together all the folks in Warrington who really take an interest in intellectual pursuits. To merge the whole of these societies in one great organisation is neither practicable nor desirable, perhaps; but it would surely be easy for them to *federate*; to each send representatives to a general council, which would regulate their procedure, avoid any overlapping, or any clashing of dates or of subjects, secure an interchange of lectures, and arrange occasional joint meetings. In matters intellectual as well as military, "union is strength." . . . .

'I believe that each particular society would benefit by such an arrangement as I have sketched, and I am confident, however disappointing individual societies may seem, that, organised upon this basis, and properly encouraged and supported, our collective force would be a revelation. But, if a federation of local societies is desirable, why not a national federation of a similar kind? Nearly every organised interest in these days has its central council, its

affiliated associations, its annual conference. One thinks at once of the Museums and Libraries Associations, or, in a widely different sphere, of the Association of Chambers of Commerce, of which, especially, I have some personal experience. The Museums and Libraries Associations carry the idea even further, and have sprouted out into district associations, with occasional district conferences. And, if museums and libraries derive so much advantage from periodical opportunities of mutual consultation, and the local chambers of commerce attach so much importance to collective influence and frequent interchange of views, why should not these methods apply to literature and to philosophy—immeasurably wider in their scope than all the rest together?’

Digging into our forgotten archives, somebody was good enough to disinter my old suggestion, and, on the 6th May, 1914, I had the privilege of presiding over a meeting of the principal societies of the town which had been specially convened to consider it, and, appropriately enough, it was held at the Old Academy. The proposal met with general approval, a committee was appointed to prepare a definite scheme, and, at a subsequent meeting, on the 10th of June, at which delegates from thirteen local societies, representing practically every branch of local intellectual activity, were present, the following resolutions were unanimously passed :—

‘1. That a Federation be formed of local societies interested in literature, science, and philosophy, or any allied subject.

‘2. That the Council consist of two members from each constituent society.

‘3. That the object of the Federation be to co-ordinate and stimulate the activities of the various societies interested in all or any of the aforesaid subjects.

‘4. That each society contribute to the expenses of the Federation *pro rata*.

‘5. That, if possible, a common place of meeting, with suitable equipment, be provided.

‘6. That the Federation arrange for the publication of a Handbook of Warrington Societies.’

It was agreed to send a copy of these proposals to all local societies which might be interested, with a request for their support, and to invite those societies which decided to identify themselves with the scheme to send two members each to a meeting of the Federation to be called early in the forthcoming session.

And, ‘after that, the deluge.’ This frightful War broke on us, like a storm of hell, before the project had matured, and, like many other hopeful and progressive movements, it is still in abeyance.

I owe the meeting an apology for having ventured to trouble them with all these personal and local details, but, after careful consideration, I came to the conclusion that I could not put my views before you in any simpler way than by telling you, as briefly as I could, the story just as it occurred. I am sure that the idea which underlies it is sound, and I am anxious that, when peace returns, it should not only be revived in Warrington, but adopted in other towns.

The object which I am anxious to promote is the gradual mobilisation of all the intellectual forces of this country. And surely the need was never more acute than now. It has become a commonplace, since the Great War started, that we are, or have been, one of the worst-organised countries in the world. The fact was visible enough before to those with eyes to see, and thoughtful men have clamoured for reforms in practically every department of our national and imperial life for years and years. But too often they were as ‘voices crying in the wilderness.’ And the lesson had to be written in lightning before our slumbrous realm would learn. Instead of developing into an ordered commonwealth, we had degenerated into a fortuitous concourse of contending atoms! Our politics had become a mere scramble for the loaves and fishes. Our churches wrangled over things irrelevant, and overlapped and competed at every turn. Have you ever seen a threshing-machine working without any supply of wheat or oats? The wheels revolve, the paddles beat, the sieves go churning to and fro, and the hum and noise of it may be heard at quite a long distance. But one peers into the open sacks and misses the expected stream of golden grain. So our politics hum and bustle, whilst the people vainly wait for the fulfilment of their dreams. And thus our churches

keep their vast machinery in motion whilst 'The hungry sheep look up and are not fed.'

Our industries were animated mainly by the greed of gain, and those of them which needed extra brains, and newer methods, and better scientific skill, were quietly appropriated by more enterprising lands. Instead of combining to make the most of their common country, the classes and the masses stood aloof and glared at each other, and ever and anon growled like two packs of hungry wolves. Although we were spending more on education than ever before, nobody was really educated, and we have not found our educational Eirenicism even yet. As for our Empire, with all its greatness and its latent loyalty, with all its untold possibilities in men and in material, it was such a ramshackle arrangement that one cannot wonder at the Germans for thinking that, when the grim hour struck, it would incontinently fall to pieces. And as for the world, the best that it could do, after an infancy of unimaginable years, was to use its ever-growing powers for purposes of sheer destruction, 'plot mutual slaughter,' and 'reel back into the beast.' But amid the chaos there has been the vision of the 'men with growing wings.' This welter of blood and sorrow has revealed such heights of human nobleness as we had never dreamed of; such possibilities of properly co-ordinated effort, turned to less ignoble uses, as the bravest hitherto had scarcely ventured to conceive.

One of the most disheartening experiences which comes to us all, at times, is the sense of loneliness in the pursuit of any great ideal, and this is particularly true in the realm of science, literature, and art. The people who really care about these things, especially in small provincial places, are so few, the discouragements so many, that sometimes we are half inclined to abandon the pursuit as hopeless, and echo the lament of Elijah in the Wilderness, 'And I, even I only, am left.' But Elijah was a moody misanthrope, and, while he was egotistically hugging to his breast the delusion that he was the only genuine prophet that remained in Israel, it was revealed to him, in the very depths of his despair and darkness, that there were seven thousand others, every one of them perhaps as loyal and as staunch as he. It is so easy to lose faith, and so futile. And appearances are often so misleading. How many of us who have been working patiently for any good and worthy cause, especially in matters intellectual, have been disposed to echo the old cry, and, seeing all our efforts unavailing, 'and the high purpose thwarted by the worm,' have felt inclined to give it up. Little Belgium might have felt like that, and Serbia, and Montenegro, and French's 'contemptible' but ever glorious 'little army.' But, instead of this, they 'stuck their corner,' and the months went by, and now the tramp of the innumerable millions comes to cheer them, and the 'forlorn hopes' of yesterday are the splendid and triumphant armies of to-morrow.

But, just as in the War we are learning to organise and mobilise our forces, on land and in the air, and on the sea and under it, in workshop and in factory, at the forge and at the plough, and thus are building an unconquerable force to fight for freedom and for righteousness, so we ought to mobilise the whole of our intellectual resources and lay them all upon the altar of the common weal. The individual, feeling helpless and disheartened, seeks for congenial spirits, and they unite to form a society. But the societies themselves are often isolated and comparatively ineffectual. Yet in nearly every town there are other men and women, and other societies with similar objects, feeling lonely too, and often enough unconscious of the neighbourhood, or even of the existence, of the rest. Taken separately, they have a curious sense of impotence. If they could but be brought together, and organised, and co-ordinated, a new enthusiasm would inspire them all. Instead of competing, they ought to co-operate. Societies with identical aims might unite, or form small federations of their own.

The idea which I have thus endeavoured to expound was intended, in the first instance, as I have said, to apply to literary and philosophical societies. But there is not any earthly reason why it should be restricted to them. The local federation whose foundations have been laid in Warrington, for instance, included, in addition to our own Society, which is primarily antiquarian, the Arts and Crafts, the Literary and Philosophical, the Philomathic, the Musical, the Photographic, the Shakespearean, the Esperanto, the Caledonian and the Welsh National Societies, the Field Club, the Municipal Officers' Guild, and

the Workers' Educational Association, and the list might be extended, reduced, or modified at will. Each of these bodies will, of course, if our scheme matures, retain its own officers and manage its own affairs, but matters common to them all will be decided by the Federation as a whole, or by its Executive Committee.

A somewhat formidable list of questions has been sent out to the members of the British Association, inviting their opinion as to the reason for the comparative unpopularity, in recent years, of scientific lectures. May I respectfully suggest that such a federation as we contemplate would probably do much to solve the problem? In my own town, for example, we have at least three institutions, the Warrington Society, the Literary and Philosophical Society, and the Philomathic Society, whose activities, upon one side, at any rate, are practical identical. But not one of them is able to obtain, except on rare occasions, a really satisfactory audience. Their dates sometimes conflict; if, as often happens, the same people are members of two or more of the societies, they cannot, in these crowded days, find time for all the lectures. Suppose that, under such a scheme as I outline, they held their lectures on alternate dates, gave interchangeable privileges of membership, organised joint lectures, and, from time to time, by pooling their resources, obtained the services of some prominent outsider, their united efforts would achieve success. Then possibly lecturing might cease to be a lost art, or a rambling and discursive talk round lantern slides or moving pictures, as it very often is to-day.

That brings me to another point we contemplated in our local scheme. The different societies at present meet in different places—ranging from 'pubs.' to clubs, and from masonic halls to church parlours. These are not always available, are often inconvenient, and are seldom able to offer the facilities which such societies require. And the rooms are either too small for the occasional, or too big for the accustomed, audiences. A federation might secure, or even build, in every town, appropriate premises containing a hall for public lectures, fitted up with a screen and lantern and the other requisite appliances, a reading room and library, with smaller rooms for less important meetings and other necessary purposes. This is quite beyond the power of separate societies as a rule. It might be practicable if they concentrated their resources. They would find a common home, and common interests, and their zeal would soon become contagious and each encourage and inspire the rest. Possibly club privileges might be added, as in the case of the Old Academy. The suburbs and adjacent villages might be linked up more or less closely with these urban federations, or form smaller federations of their own. On these lines, we might light, in every part of England, a series of intellectual candles which all the world's indifference would not readily put out.

Of course, my project would not end with towns, or suburbs, or even with adjoining places. District federations, as I have already indicated, would be a natural corollary, and each of these, in turn, would stimulate and co-ordinate the intellectual life of its own area. I have already given illustrations, and I need not labour the matter. Just as the adjacent towns were linked up with the district federations, so these, in turn, would be linked up with the central organisation, national, imperial, or cosmopolitan, as the case might be. Every branch of intellectual activity might have its corresponding groups of small societies united in a series of federations—say, a federation of field clubs, or astronomical, or geological, or geographical, or botanical, or zoological, or antiquarian, or literary, or musical societies. The principle is sufficiently elastic to embrace them all. Whenever there is a common purpose there ought to be united effort to secure it. Wherever there is room for local independence and initiative they ought to be maintained. Suppose, for the sake of argument, that all the scientific societies in the Kingdom sent representatives to the British Association! Suppose that all the societies interested in letters sent representatives to the Royal Society of Literature, or some new central body! One of the latest is an International Institute of British Poetry, by the way. Suppose the Royal Society of Arts became the foster-mother of a federation of societies interested in painting, in sculpture, in music, and the rest! Individual membership, as in the case of some of the existing organisations—the British Association itself, for example—might be supplemented by representative authority. And, if existing institutions did

not lend themselves to these developments, new institutions might be started on more liberal and democratic lines. And all these different bodies might be linked together in their turn. As a matter of fact, this Annual Conference of Corresponding Societies, in some respects, might well be taken as a sort of working model. It is, at any rate, an admirable illustration. A number of societies with cognate aims, each busy with its own activities and managing its own affairs, unite for consultation by sending delegates to a central meeting, which appoints its own officials and brings the various scattered units into closer touch. That, according to my view, is federation. The process simply needs extending, the Annual Conference developing into a definite system of continuous co-operation, and the scheme I advocate, in one particular department of our intellectual activity, at any rate, is actually achieved.

But why should we stop at this? Literature and Art are the 'beautiful, but ineffectual, angels' who have too long been 'beating in the void their luminous wings in vain.' They want to 'plump their exquisite proportions on bread and butter;' to apply a little practical common sense to their methods.

Thus I end where I began. If in the simple principle of 'union for common purposes and liberty in matters of separate concern' we may unite our forces for social progress and imperial safety; may harmonise the claims of nationality and empire; of human brotherhood and patriotic pride in our own land; of separate worship and of the great common faith; if it will subdue the strife of races and the clash of creeds, till

'All in their unlikeness blend  
Confederate to one golden end,'

and war becomes a thing impossible—a hideous nightmare of a dark and dreadful past—the magic word may likewise be the 'Open Sesame' to not less notable achievements in the things which matter most of all—the realm which embraces all knowledge, and is as wide as that 'universal creation which,' in the language of Camille Flammarion, 'is an immense harmony, of which the Earth is but an insignificant, rather uninteresting, and unfinished fragment.'

Mr. WILLIAM WHITAKER (Croydon Natural History and Scientific Society) expressed his appreciation of the paper, and thought that much might be done. He strongly objected, however, to the way in which the author ran down our own country, for he held that we organised grandly.

Dr. J. F. TOCHER (Buchan Field Club) said that in the North of Scotland a Federation of Northern Scientific Associations had existed for many years. At the meetings of the combined societies, held annually in various centres in succession, papers were read and ideas exchanged with great benefit to the individual bodies. For a specific object federation was an excellent principle. He did not fully agree with the view of Mr. Whitaker that organisation of effort was a special feature in the British Isles, but he had no doubt whatever that the capacity of organisation of Britons was high. He cordially supported the idea of federation, not only in scientific matters, but also in the political field. It should not, however, be imagined that federation was an instrument which could secure the maintenance or increase of racial fitness.

Mr. H. SOWERBUTTS mentioned that about four years ago the Educational Societies of Manchester joined together in a loose kind of federation. Each of about 30 Societies sent two representatives, usually the Chairman and the Secretary, to form a 'Committee of the Associated Educational Societies'; this Committee elected a small Executive Committee of about a dozen forming a permanent body. Each Society paid a contribution of 5s. per year to cover postage, printing, &c. The three main objects were to hold an Annual Reunion of all the members, to avoid clashing of the ordinary meetings of the Societies with one another, and to arrange, if possible, for open meetings to be held by the different Societies. Of course, each Society goes on as before with its ordinary proceedings.

He further remarked that, with reference to the suggestion of a common room for a Federation of Societies, especially if arranged for by an outside body, there seemed to be two difficulties, (1) as to who should have preference, and (2) if there were many Societies in the Federation, and as there are only six weekdays, one room might not suffice.

The CHAIRMAN (Mr. Sheppard) regretted very much that the War prematurely

concluded the excellent scheme which the author had formulated at Warrington. He hoped that in a few years' time Mr. Bennett would come forward and inform the Conference what real success had attended his efforts. Mr. Sheppard referred to the work of certain Unions, which cover districts; and saw no reason why a similar scheme should not be successful in a town where many different societies exist.

Dr. WILLIAM LAWSON (Statistical and Social Inquiry Society of Ireland) supported the views in the paper. He hoped that more Societies would be affiliated to the Association, and dwelt on the advantage to Societies in Ireland being brought in touch with the Association by being represented at its meetings.

Mr. M. A. B. GILMOUR (Andersonian Naturalists' Society) showed how natural history societies of the south-west of Scotland are coming together.

The Rev. T. R. R. STEBBING said: Sir Daniel Morris has kindly left it to me to explain how in some respects Mr. Bennett's desires have been already satisfied. Besides the great organisation of science in the north of England with which our vice-president, Mr. Sheppard, is so intimately connected, we have in the south-west of England the Devonshire Association for the Advancement of Science, Literature, and Art, founded in 1862, and for the past twenty years the South-Eastern Union of Scientific Societies has been doing its best to carry out the principle of co-operation on which it was founded. Its title is commonly abbreviated into S.E.U.S.S., suggesting that we wish to see ourselves as others see us. The objects indeed at which Mr. Bennett is aiming are no doubt highly desirable. But the attainment of such aims seems ever to be tinged with Utopian romance, for it can scarcely be forgotten that the present war broke out on August 4, 1914, while, I believe, the 15th of that very month, by the fine irony of coincidence, had been arranged for the opening of the International Peace Congress in Austria!

Mr. JOHN ASHWORTH (Manchester Geological and Mining Society) pointed out that the Manchester Geological and Mining Society was federated with the Institution of Mining Engineers, Professor Louis being its delegate, along with the other Mining Institutes, except that of South Wales, which in time may join. Consequently his Society received all the other transactions, and the scheme so far works satisfactorily.

Alderman BENNETT, in replying, said that he did not intend to suggest that England was not able to organise, but that, as a matter of fact, she had not organised. He felt that, if she really rose to the height of her opportunities, there was not any nation in the world which was capable of greater things. In spite of all the horrors of the war, he was still a believer in Utopia, and was of opinion that the universe would stultify itself if 'good' were not the 'final goal of ill.' He was deeply grateful to the audience for their kind reception of his paper, and was delighted to find that the idea he had so long been advocating was making such satisfactory progress. He was more and more convinced that Federation was the clue to the solution of many of our difficulties, social, political, religious and intellectual, and, if he were in order, he should like to bring the discussion to a practical conclusion by moving:

'That the Committee of the Conference of Delegates be requested to recommend the various constituent societies to consider the desirability of forming local and national federations of societies with kindred aims.'

This proposition was put to the meeting and carried.

Mr. WILLIAM WHITAKER, in the absence of Mrs. HESTER FORBES JULIAN (Torquay Natural History Society) owing to illness, read her paper on

### *The Importance of Kent's Cavern as a National Site.*

It is the unanimous opinion of geologists and anthropologists that the site of Kent's Cavern is of national importance, and, as such, should be properly secured. This question, and the larger one of the nationalisation of similar places, will be discussed by the delegates, and in this paper I shall confine myself to a brief description of the explorations conducted by my father, William Pengelly, F.R.S. The intervening years have served to securely establish their value, for, in the words of the late Lord Lister, 'the importance of



his acutely planned and perseveringly conducted cave exploration is recognised throughout the scientific world.'

The accounts of the different deposits and the various remains found therein are here only briefly alluded to, for the 16 yearly reports of the Kent's Cavern explorations, written by William Pengelly himself, have been published in full in the Reports of the British Association. For want of time I also pass over the question as to which of the implements exhumed may be considered to be of the Magdalenian, Acheulean, or Chellean type.

As long ago as 1846 William Pengelly and his friends, Mr. Vivian and Dr. Battersby, received from the Torquay Natural History Society a small grant to enable them to make some researches in Kent's Hole. It was visited and slightly investigated by Mr. Northmore and Sir W. Trevelyan in 1824, and partially explored by the Rev. J. MacEnery in 1825, and by Mr. R. A. C. Godwin-Austen in 1840. The results of these fresh investigations by William Pengelly and his colleagues were communicated to their own Society and to the Geological Society, and an account of all the earlier work done at the cavern has been given by my father in the Transactions of the Devonshire Association. Although important results were obtained, and it was proved that the flint implements and the remains of extinct animals did occur together in the same deposits, public opinion was unprepared to accept some of the most striking conclusions. It was not until nearly twenty years had elapsed, and after the exploration of Brixham Cavern, that a committee was appointed at the Bath meeting of the British Association in 1864 for the regular exploration of the cave.

This exploration at Kent's Hole was undertaken by a committee, but, again, practically almost the whole of the work fell on William Pengelly. The excavations commenced in March 1865, and were concluded in June 1880. The proprietor, the late Lord Haldon, placed the cavern entirely in the custody of the committee, but since his death it has fallen into other hands.

The cavern is about a mile east from Torquay Harbour in a small wooded limestone hill on the western side of a valley which terminates about half a mile southwards on the northern shore of Torbay. There are two entrances to the cavern, about fifty feet apart, in the face of the same low, vertical natural cliff, running nearly north and south, on the eastern side of the hill. Both these entrances are about six feet in height and rather more in width, thus affording easy access to the cave.

Much ground still remained intact, although Mr. MacEnery and other explorers had broken up some portions of the deposits. William Pengelly therefore selected for the first attempt a part of the cavern called the Great Chamber, which was not only intact, but also seemed likely to present few difficulties in exploration. The material which composed the floor of the cave exhibited, as a rule, the following downward succession: blocks of limestone, sometimes very large, which had clearly fallen from the roof, a layer of mould, almost black, ranging from only a few inches to upwards of a foot in depth, known as the black mould. Beneath this was found a floor of granular stalagmite, firmly attached to the walls, seldom less and frequently more than a foot in thickness, doubtless formed by the drip of water from the roof. Next a local band of black earth showing evidences of fire. Then a red cave-earth or loam, containing many limestone fragments, varying in size from bits not larger than a sixpence to masses hardly less than those lying on the surface of the mould; this exhibited no signs of stratification, and contained numerous interesting remains. Later the crystalline stalagmite was discovered, and the oldest deposit, a breccia-detritus of Devonian grits, containing 'nodule' tools and bones of cave bear.

When the explorations commenced, only three deposits were known, namely, the black mould, succeeded by the granular stalagmite, overlying the cave-earth. However, as the work proceeded, a section was laid bare, which clearly showed in downward sequence the floor of granular stalagmite, then the cave-earth, next the crystalline stalagmite, and finally the breccia.

The importance of my father's discoveries in Kent's Hole of flint tools and weapons rudely chipped by prehistoric man was increased by the evidence of a gradual advance in the character of the implements, and supplemented by the further bringing to light of bone needles and harpoons. The revolution

which Darwin's theory (promulgated in 1859) made in the conception of the order and inter-relation of life-forms was scarcely more momentous than that wrought by the discoveries of various geologists, to which William Pengelly himself contributed through his work at Brixham Cave and Kent's Hole, since the old beliefs concerning man gradually gave way before the proofs of his slow advance from savagery to civilisation. The exploration soon rewarded the geologist by yielding many remarkable specimens, and in the reports rendered at Birmingham in 1865, and at Nottingham in 1866, he described the various objects met with, which included implements of human origin, together with remains of mammoth, cave-bear, and their extinct contemporaries.

In the report for the year 1867 (the third) which he read at the meeting at Dundee, my father mentioned the human jaw in which so much interest has recently been taken by Dr. Duckworth. This was found deeply embedded in granular stalagmite, and was described in the following manner:—

'The human remains are a tooth and a portion of an upper jaw containing four teeth. They were found lying together in the vestibule about thirty feet from the northern entrance of the cavern, and deeply embedded in the floor, which was twenty inches thick. These interesting relics—the most ancient remains of man's osseous system which the cavern has yet yielded—were found on the 3rd of January 1867.'

'There is reason to believe that a few persons continue to be sceptical respecting the artificial character of even the best unpolished flint implements found in the cavern or elsewhere. The Committee venture to entertain the opinion that the evidence which the last twelve months have put into their possession renders it impossible for anyone to doubt that man occupied Devonshire when it was also the home of the now extinct lion, hyæna, rhinoceros, mammoth, and their contemporaries.'

'Of the tools, two . . . the bone awl and the harpoon [were] found in the black band, beneath the stalagmitic floor in the vestibule. . . . In this same thin band there occurred, with the implements just mentioned, teeth of rhinoceros, hyæna, and other of the common cave mammals; and the story they tell is at once clear and resistless. These, however, are neither the only nor the best bone implements which have been exhumed. Two others have been met with, and both of them in the red cave-earth below the black band. One is a portion of a highly-finished harpoon two and a quarter inches in length, and differing from that previously mentioned in the form of its point, and being barbed on two sides. . . . This implement was met with in the vestibule, in the second foot-level of red cave-earth. Vertically above these two feet of loam there lay the black band about three inches thick, and containing flint flakes and remains of extinct animals. Over this again came the stalagmitic floor eighteen inches thick, granular towards its base, crystalline and laminated towards the upper surface, continuous in all directions, unquestionably intact, and without fracture or crevice of any kind, and superposed on this was the ordinary black mould, with Romano-British potsherds. . . . The second bone tool from the cave-earth is a well-finished pin three and a quarter inches in length.' A bone needle, partially covered with stalagmite, was also found during the year's exploration.

Professor Boyd Dawkins and Mr. Ayshford Sandford visited Torquay in the autumn of 1868 for the purpose of inspecting and assisting in the classification of the bones found in the cavern.

According to his invariable custom, the explorer attended the British Association which met at Exeter in 1869, and, the city being near Torquay, many of the geologists present took the opportunity of visiting the cave under his guidance, and discussing the various problems suggested by the deposits. At the gatherings of the Association at Liverpool in 1870, and at Edinburgh in the following year, the discoveries made at Kent's Hole excited exceptional interest and attention, especially in the northern capital.

My father announced an important 'find' in the following words at the close of his annual report (read before the Geological Section at Brighton): 'The other specimen is a well-marked incisor of *Machairodus latidens*, found July 29, 1872. One of the hopes of the Cavern Committee, in commencing their researches, was that they might find some traces of *Machairodus*. This they have never abandoned, though year after year passed away without success, and they cannot but express their gratitude to the body whose patience and

liberality has enabled them to continue their labours until this hope was realised.'

William Pengelly was President of the Geological Section of the British Association at Plymouth in 1877, and chose for the subject of his address 'The History of Cavern Exploration in Devonshire.' A strong body of geologists attended, and afterwards came to Torquay to witness the memorials of a vanished past under the President's direction. They were enthusiastic in their appreciation of the wonders of the cave and the specimens disinterred from it.

The sixteenth and last report, presented at Swansea, records the completion of the work in June 1880, and gives an account of a second and deeper excavation in that part of the cavern named the Long Arcade. This was especially interesting, being carried to an additional depth of five feet below the bottom of the four-feet excavation, making a total depth of nine feet below the bottom of the floor of granular stalagmite; it was thus made almost entirely in the well-known breccia. Only eighteen finds were made. Three good 'nodule' tools were met with in the eighth foot-level, and several flint chips in the ninth or lowest. Of the animal remains two were bear's teeth, and one the crown of the tooth of a rhinoceros. No animal relic was found beneath the seventh foot-level.

It is worthy of remark that this second and deeper excavation yielded a greater number of archeological than of palæontological finds.

A list comprising the more important mammals found in the cave-earth of Kent's Hole may be of interest, and is therefore appended:—

<i>Felis leo</i> , var. <i>spelæa</i> , cave lion . . . . .	abundant.
<i>Machairodus latidens</i> , sabre-toothed tiger . . . . .	very rare.
<i>Hyæna crocuta</i> , var. <i>spelæa</i> , cave hyæna . . . . .	very abundant.
<i>Canis lupus</i> , wolf . . . . .	rare.
<i>Canis vulpes</i> , var. <i>spelæus</i> , large fox . . . . .	rare.
<i>Gulo luscus</i> , glutton . . . . .	very rare.
<i>Ursus spelæus</i> , cave bear . . . . .	abundant.
<i>Ursus ferox</i> , grizzly bear . . . . .	abundant.
<i>Ursus arctos</i> , brown bear . . . . .	scarce.
<i>Elephas primigenius</i> , mammoth . . . . .	not very common.
<i>Rhinoceros tichorhinus</i> , woolly rhinoceros . . . . .	abundant.
<i>Equus caballus</i> , horse . . . . .	very abundant.
<i>Bos primigenius</i> , urus . . . . .	scarce.
<i>Bison priscus</i> , bison . . . . .	abundant.
<i>Cervus megaceros</i> , Irish elk . . . . .	not uncommon.
<i>Cervus elaphus</i> , stag . . . . .	abundant.
<i>Cervus tarandus</i> , reindeer . . . . .	abundant.
<i>Lepus timidus</i> , hare . . . . .	rare.
<i>Lagomys spelæus</i> , cave pika . . . . .	very rare.
<i>Arvicola amphibius</i> , water vole . . . . .	rare.
<i>Arvicola agrestis</i> , field vole . . . . .	rare.
<i>Arvicola pratensis</i> , bank vole . . . . .	very rare.
<i>Castor fiber</i> , beaver . . . . .	scarce.

The fauna of the breccia consisted almost exclusively of remains of bear, but there were traces also of lion, fox, and deer.

Calling attention to a matter of great importance in comparing the implements found in the breccia and the cave-earth, my father writes:—

'A glance at the implements from the two deposits shows that they are very dissimilar. Those from the breccia are much more rudely formed, more massive, have less symmetry of outline, and were made by operating, not on flakes purposely struck off from nodules of flint or chert, as in the case of those from the cave-earth, but directly on the nodules themselves, all of which appear to have been obtained from accumulations of supracretaceous flint gravel, such as occur about four miles from the cavern. There seems no doubt that the breccia men were ruder than those of the cave-earth, and this is borne out by the fact that, whilst the men represented by the less ancient deposit made bone tools and ornaments—harpoons for spearing fish, eyed needles or bodkins, probably for joining skins together, awls, perhaps to facilitate the passage of

the slender needle or bodkin through the tough thick hides, pins for fastening the skins they wore, and perforated badgers' teeth for necklaces or bracelets—nothing of the kind has been found in the breccia. In short, the stone tools, though both sets were unpolished and coeval with extinct mammals, represent two distinct civilisations. It is equally clear that the ruder men were the more ancient, for their tools were lodged in a deposit, which, whenever the two occurred in the same vertical section, was invariably the undermost.'

The deposits differed very markedly in character, being frequently separated by stalagmite, a breaking up of which and partial clearing out of the breccia having preceded the deposition of the cave-earth; my father, therefore, drew the inference that there must have been a period of time between the two, incapable of compression within narrow limits, and representing a great chronological interval.

The trouble of inspecting the disinterring of the cavern-remains from their resting-place, and the patience and skill required in identifying them, can hardly be estimated by those who have not undertaken similar work. In 1896 Professor Boyd Dawkins writes thus of William Pengelly's labours: 'Day by day, except when the work was stopped, he visited the cave and recorded on maps and plans the exact spot where each specimen was found, for no less than sixteen years. The vast collection of palæolithic implements and fossil bones, each of which bears traces of his handiwork, is represented in most of the museums in this country, and the annual reports, listened to with so much pleasure by crowds at the meetings of the British Association, are the most complete that have ever been published. It may be objected that the accumulation of so much evidence of the existence of man in the Pleistocene age in the South of England was unnecessary. It was, however, necessary to sweep away the mass of prejudice, and this could best be done by repeating the evidence. Had this not been done, man would not occupy the recognised position which he now holds in the annals of geology.'

As already stated, the cavern has now passed into private hands, and Dr. Duckworth writes in 1912: 'A visit to Kent's Cavern will convince even the uninitiated that this treasury is by no means exhausted. And a word of protest must be uttered against the seemingly indiscriminate disposal of bones and possibly also of implements which seems to proceed daily. On June 20, 1912, a fine flake of Magdalenian aspect was obtained. Two days later when I visited the cavern a new passage of about twenty-five feet in depth had just been broken into. It is therefore expedient to impress upon all who are interested in prehistoric archaeology the sad fact of this continual leakage and the loss of material of the greatest possible value.'

Professor Keith, who inspected Kent's Hole somewhat later, also felt the advisability of securing a site of such national importance, as its further careful investigation might be a great boon to science.

The CHAIRMAN said that as to the value and scientific importance of the caves so ably worked by Pengelly there can be no question, and it would certainly be a calamity if anything happened to the caves at the hands of the vandals. He himself had recently received some bones and teeth from a friend, not at all interested in geology, who obtained them from a person at Torquay, who had taken them from the cave a little while ago. The National Trust or some other body should take the question of the future preservation of the Torquay caves in hand. Possibly the Torquay Naturalists' Society might do something.

Mr. MARK L. SYKES considered that the work carried out by the late Mr. Pengelly at Kent's Cavern was of the highest importance, as having given positive and unimpeachable proof of the enormous antiquity of man, such as has been exceeded and probably approached by no other evidence. For the cave to pass into the hands of irresponsible persons, who had neither the knowledge nor appreciation of its value, was nothing less than a calamity, especially in view of the statements which had been made as to what is now being done there. Immediate steps should be taken to secure the cave in the interests of science, and he felt this so strongly that he was prepared to take active personal steps, and participate in raising sufficient funds for the purchase and preservation of the cave and placing it under proper control, so that further investigations may be conducted on a systematic and scientific basis.

The Rev. T. R. R. STEBBING heartily supported the proposal that Kent's Cavern should be included among our national treasures, as a fitting memorial of Mr. Pengelly's great services to science in its exploration. So undeviating was his assiduity in the work that on one occasion, when he was kept at home by illness; although the age of miracles is past, his boots (they say) started cavewards without him. In familiar intercourse with him, which Mr. Stebbing enjoyed for several years, he could not say that Pengelly himself ever vouched for the fact. He was in truth a sturdy upholder of scientific morality and scientific accuracy. He could not agree with those who claimed, as their own, ideas which they had consciously borrowed from others or who would not acknowledge frankly their own mistakes. In his essay, 'Is it a fact?' he issued a challenge to irrational absurdities in general.

Other speakers, including Mr. WHITAKER and Sir EDWARD BRABROOK, expressed their appreciation of the paper and the need for securing Kent's Cavern. The Secretary was instructed to see what possibilities existed of acquiring the site.

In conclusion, it was resolved, on the proposition of Mr. WHITAKER, seconded by Mr. MARK SYKES, that the Council of the Association be requested to take steps for the preservation of Kent's Cavern.

The following Delegates attended the Conference and signed the attendance book, their attendance being indicated by the figures 1, 2, which refer respectively to the first and second meeting.

#### AFFILIATED SOCIETIES.

1 2 Andersonian Naturalists' Society . . . . .	M. A. B. Gilmour, F.Z.S.
1 Ashmolean Natural History Society of Oxfordshire . . . . .	G. Claridge Druce, M.A.
1 2 Belfast Naturalists' Field Club . . . . .	Dr. J. K. Charlesworth,
1 Berwickshire Naturalists' Field Club . . . . .	G. P. Hughes, J.P.
1 2 Bournemouth Natural Science Society . . . . .	Sir Daniel Morris, K.C.M.G.
1 Brighton and Hove Natural History and Philo- sophical Society . . . . .	Alfred W. Oke, F.G.S.
2 Buchan Field Club . . . . .	J. F. Tocher, D.Sc.
1 2 Caradoc and Severn Valley Field Club . . . . .	Prof. W. W. Watts, F.R.S.
1 2 Croydon Natural History and Scientific Society . . . . .	W. Whitaker, F.R.S.
1 2 Dorset Natural History and Antiquarian Field Club . . . . .	Sir Daniel Morris, K.C.M.G.
1 Edinburgh Field Naturalists' and Microscopical Society . . . . .	R. C. Millar.
1 Edinburgh Geological Society . . . . .	R. C. Millar.
1 Elgin Literary and Scientific Association . . . . .	J. S. Flett.
1 Glasgow Geological Society . . . . .	Prof. J. W. Gregory, F.R.S.
1 2 Glasgow Natural History Society . . . . .	Mrs. E. R. Ewing.
1 Glasgow Royal Philosophical Society . . . . .	C. R. Gibson, F.R.S.E.
1 Hampshire Field Club and Archæological Society . . . . .	W. Dale, F.S.A.
1 2 Hertfordshire Natural History Society and Field Club . . . . .	W. Whitaker, F.R.S.
2 Holmesdale Natural History Club . . . . .	Miss M. C. Crosfield.
1 2 Hull Geological Society . . . . .	T. Sheppard, F.G.S.
1 2 Hull Scientific and Field Naturalists' Club . . . . .	T. Sheppard, F.G.S.
1 Ipswich and District Field Club . . . . .	Dr. P. G. H. Boswell, F.G.S.
1 Ireland, Statistical and Social Inquiry, Society of . . . . .	William Lawson, LL.D.
1 Leicester Literary and Philosophical Society . . . . .	Miss C. Measham.
1 2 London: Selborne Society . . . . .	W. M. Webb, F.L.S.
2 Manchester Geographical Society . . . . .	Harry Sowerbutts.

2	Manchester Geological and Mining Society	John Ashworth.
1	Manchester Microscopical Society	Mark L. Sykes.
1	Museums Association	Dr. F. A. Bather, F.R.S.
1 2	Northumberland, Durham, and Newcastle-on-Tyne Natural History Society	C. E. Robson.
1 2	Paisley Philosophical Institution	John Woodrow, F.R.Met.S.
1	Rochdale Literary and Scientific Society	J. R. Ashworth, D.Sc.
1	Vale of Derwent Naturalists' Field Club.	R. S. Bagnall, F.L.S.
1	Worcestershire Naturalists' Club	W. H. Barnes.
1 2	Yorkshire Geological Society.	T. Sheppard, F.G.S.
1 2	Yorkshire Naturalists' Union.	T. Sheppard, F.G.S.
2	Yorkshire Philosophical Society	Rev. W. Johnson, B.A.

## ASSOCIATED SOCIETIES.

1 2	Balham and District Antiquarian and Natural History Society	Sir Edward Brabrook, C.B.
1 2	Hastings and St. Leonards Natural History Society	G. Willson.
1 2	Leeds Naturalists' Club and Scientific Association.	Greevz Fysher.
1 2	Lewisham Antiquarian Society	Sir Edward Brabrook, C.B.
1 2	School Nature Study Union	Mrs. White, D.Sc.
1 2	Tunbridge Wells Natural History and Philosophical Society	Rev. T. R. R. Stebbing, F.R.S.
2	Warrington Society	Arthur Bennett, J.P.
1	Wimbledon Natural History Society	Dr. F. A. Bather, F.R.S.

THE CORRESPONDING SOCIETIES OF THE BRITISH ASSOCIATION FOR 1916-1917.  
*Affiliated Societies.*

Full Title and Date of Foundation	Headquarters or Name and Address of Secretary	No. of Members	Entrance Fee	Annual Subscription	Title and Frequency of Issue of Publications
Andersonian Naturalists' Society, 1888	Royal Technical College, Glasgow. Harry G. Channing	210	2s. 6d.	2s. 6d.	Annals, occasionally.
Ashmolean Natural History Society of Oxfordshire, 1828	Miss A. L. Stone, 2 St. Margaret's Road	280	None	5s.	Proceedings and Report, annually.
Belfast Natural History and Philosophical Society, 1821	Museum, College Square. J. M. Finnigan	200	None	1l. 1s.	Report and Proceedings, annually.
Belfast Naturalists' Field Club, 1863	Museum, College Square	330	5s.	5s.	Report and Proceedings, annually.
Berwickshire Naturalists' Club, 1881	Rev. J. J. M. L. Aiken, B.D., Manse of Ayrton, Berwickshire	300	10s.	7s. 6d.	History of the Berwickshire Naturalists' Club, annually.
Birmingham and Midland Institute Scientific Society, 1859	H. M. Francis, Birmingham and Midland Institute, Paradise Street, Birmingham	117	None	10s. 6d. and 5s.	Records of Meteorological Observations, annually.
Birmingham Natural History and Philosophical Society, 1858	Arebury House, Newhall Street, Birmingham. W. H. Foxall, F.R.G.S.	207	None	1l. 1s.	Proceedings, annually.
Bournemouth Natural Science Society, 1903	R. A. de Paiva, 13 Carysfort Road, Bournemouth	398	None	10s.	Proceedings, annually.
Brighton and Hove Natural History and Philosophical Society, 1864	J. Colbatch Clark, 9 Marlborough Place, Brighton	121	None	10s.	Report, annually.
Bristol Naturalists' Society, 1862	Dr. O. V. Darbishire, The University, Bristol	150	5s.	10s. and 5s.	Proceedings, annually.
British Mycological Society, 1898	Carleton Rea, 34 Foregate Street, Worcester	141	None	10s.	Transactions, annually.
Buchan Club, 1887	J. F. Tocher, D.Sc., Crown Mansions, Union Street, Aberdeen	180	5s.	5s.	Transactions, annually.
Burton-on-Trent Natural History and Archaeological Society, 1876	A. Slator, D.Sc., 174 Ashby Road, Burton-on-Trent	150	None	6s.	Report, annually; Transactions, occasionally.
Canada, Royal Astronomical Society of, 1884	Canadian Institute Building, Toronto, J. R. Collins	550	None	2 dollars	Journal, monthly; Handbook, annually.
Caradoc and Severn Valley Field Club, 1893	H. E. Forrest, 37 Castle Street, Shrewsbury	185	5s.	5s.	Transactions and Record of Bare Facts, annually.
Cardiff Naturalists' Society, 1867	G. D. Shepherd, Gresham Chambers, Kingsway, Cardiff	500	None	12s. 6d.	Transactions, annually.
Chester Society of Natural Science, Literature, and Art, 1871	Grosvenor Museum, Chester. G. P. Milin	900	None	5s. and 2s. 6d.	Report and Proceedings, annually.
Cornwall, Royal Geological Society of, 1814	The Museum, Public Buildings, Penzance. F. H. Uren	82	None	1l. 1s.	Transactions, annually.
Cornwall, Royal Institution of, 1818	Henry Jenner, F.S.A., County Museum, Truro	191	None	1l. 1s.	Journal, annually.
Cornwall, Royal Polytechnic Society, 1833	E. W. Newton, Pendarves Road, Camborne, Cornwall	300	None	10s.	Report, annually.
Cotteswold Naturalists' Field Club, 1846	L. Richardson, 10 Oxford Parade, Cheittenham	121	1l.	15s.	Proceedings, annually.
Croydon Natural History and Scientific Society, 1870	Public Hall, Croydon. Miss G. Bigby	130	None	10s., 5s., and 2s. 6d.	Proceedings and Transactions, annually.
Dorset Natural History and Antiquarian Field Club, 1875	Rev. Herbert Pentin, M.A., St. Peter's Vicarage, Portland	400	10s.	10s.	Proceedings, annually.

## Affiliated Societies—continued.

Full Title and Date of Foundation	Headquarters or Name and Address of Secretary	No. of Members	Entrance Fee	Annual Subscription	Title and Frequency of Issue of Publications
Dublin Naturalists' Field Club, 1885 . . . . .	Mrs. Long, 4 Palmerston Villas, Upper Rathmines, Dublin	67	5s.	5s.	'Irish Naturalist,' monthly; Report, annually.
Dumfriesshire and Galloway Natural History and Antiquarian Society, 1862 . . . . .	R. Wallace, Ewart Public Library, Dumfries	350	None	5s.	Transactions and Proceedings, annually.
Durham, University of, Philosophical Society, 1896 . . . . .	J. A. Smythe and J. W. Bullerwell, Armstrong College, Newcastle-on-Tyne	200	None	10s. and 5s.	Proceedings, half-yearly.
East Anglia, Prehistoric Society of, 1908 . . . . .	W. G. Clarke, 12 St. Philip's Road, Norwich	250	None	5s.	Proceedings, annually.
East Kent Scientific and Natural History Society, 1867 . . . . .	A. Lander, J.P., 17 High Street, Canterbury	60	None	10s. and 5s.	Transactions, annually.
Esthorne Natural History, Photographic, and Literary Society, 1867 . . . . .	Miss Jay, Technical Institute, Eastbourne	220	2s. 6d.	5s.	Transactions and Journal, quarterly.
Edinburgh Field Naturalists' and Microscopical Society, 1869 . . . . .	Allan A. Pinkerton, 20 George Street, Edinburgh	208	None	5s.	Transactions, annually.
Edinburgh Geological Society, 1834 . . . . .	Synod Hall Buildings, Castle Terrace, Edinburgh. J. J. McBeath	250	10s. 6d.	12s. 6d.	Transactions, annually.
Elgin and Morayshire Literary and Scientific Association, 1836 . . . . .	H. B. Mackintosh, Redythie, Elgin . . . . .	130	None	5s.	Transactions, occasionally.
Essex Field Club, 1880 . . . . .	Essex Museum of Natural History, Romford Road, Stratford, W. Oole	300	None	15s.	'Essex Naturalist,' half-yearly.
Glasgow, Geological Society of, 1858 . . . . .	Peter Macnair, F.R.S.E., and H. R. J. Conacher, 207 Bath Street, Glasgow	197	None	10s.	Transactions and Proceedings, annually.
Glasgow, Natural History Society of, 1851 . . . . .	Alex. Ross, 409 Great Western Road, Glasgow	235	None	7s. 6d.	'Glasgow Naturalist,' quarterly.
Glasgow, Royal Philosophical Society of, 1802 . . . . .	Prof. Peter Bennett, 207 Bath Street, Glasgow	1,000	17. 1s.	17. 1s.	Proceedings, annually.
Hampshire Field Club and Archeological Society, 1885 . . . . .	W. Dale, F.S.A., F.G.S., The Lawn, Archer's Road, Southampton	260	5s.	10s. 6d.	Proceedings, annually.
Hampstead Scientific Society, 1899 . . . . .	C. O. Barrtrum, B.Sc., and R. W. Wylie, M.A., 32 Willowghy Road, Hampstead, N.W.	308	None	Minimum 5s.	Report and Proceedings, annually.
Hertfordshire Natural History Society and Field Club, 1875 . . . . .	John Hopkinson (Librarian), Westwood, Watford	160	None	10s.	Transactions, one or two parts annually.
Holmesdale Natural History Club, 1857 . . . . .	Mrs. Perrin, Clears Corner, Reigate	74	None	10s. and 5s.	Proceedings, occasionally.
Hull Geological Society, 1889 . . . . .	J. W. Stather, F.G.S., Newland Park, Hull . . . . .	70	None	5s.	Transactions, occasionally.
Hull Scientific and Field Naturalists' Club, 1886 . . . . .	T. Steinforth, B.A., The Museum, Hull . . . . .	140	None	5s.	Transactions, annually.
Institution of Mining Engineers, 1889 . . . . .	Percy Strzelecki, 33 Victoria Street, London, S.W.	3,600	None	None	Transactions, monthly.
Ipswich and District Field Club, 1903 . . . . .	Miss M. Fitcher, Nacton Road Schools, Ipswich	115	None	2s. 6d.	Journal, occasionally.
Ireland, Statistical and Social Inquiry Society of, 1847 . . . . .	W. Lawson, Dr. N. M. Falkiner, and Herbert Wood, 95 Stephen's Green, Dublin	80	None	1s.	Journal, annually.
Leeds Geological Association, 1873 . . . . .	E. Hawkesworth, Cross Gates, Leeds	116	None	5s.	Transactions, occasionally.
Leicester Literary and Philosophical Society, 1835 . . . . .	Corporation Museum. F. B. Lott, 7 Stoneycgate Avenue, Leicester	280 Membs. & Associates	None	Members 14. 1s.; Associates 10s. 6d.	Transactions, annually.
Lincolnshire Naturalists' Union, 1893 . . . . .	Arthur Smith, F.L.S., City and County Museum, Lincoln	112	None	5s.	Transactions, annually.



Liverpool Biological Society, 1886	J. A. Clubb, D.Sc., Free Public Museum, Liverpool pool	80	None	17. 1s.	Proceedings and Transactions, annually.
Liverpool Botanical Society, 1906	E. Horton, Common Hall, Hackens Hey, Liverpool pool	123	None	5s.	'Lancashire and Cheshire Naturalist,' usually monthly.
Liverpool Engineering Society, 1875	T. R. Wilton, M.A., 1 Crosshall Street, Liverpool	599	None	17. 1s., 10s. 6d., and 5s.	Transactions and Report, annually.
Liverpool Geographical Society, 1891	A. Ellis Cookson, 5 Hargreave's Buildings, Liverpool pool	600	None	Members 17. 1s.; Associates 10s. 6d.	Transactions and Report, annually.
Liverpool Geological Society, 1859	T. A. Jones, 27 Rockfield Road, Anfield, Liverpool	78	None	10s. 6d.	Proceedings, annually.
London: Quekett Microscopical Club, 1865	Jas. Burton, 4 Somal Road, West Hamstead, N.W.	450	None	10s.	Journal, half-yearly.
London: Selborne Society, 1885	Avenue Chambers, Bloomsbury Square, W.C. W. M. Webb, F.L.S.	2,500	None	5s.	'Selborne Magazine,' monthly.
Man, Isle of, Natural History and Antiquarian Society, 1879	W. Percy Cowley, Ramsey, Isle of Man	275	2s. 6d.	7s. 6d. and 5s.	Proceedings and Transactions, annually.
Manchester Geographical Society, 1884	E. Steinthal and H. Soverbutts, 16 St. Mary's Parsonage, Manchester	686	None	Members 17. 1s.; Associates 10s. 6d.	Journals, quarterly.
Manchester Geological and Mining Society, 1838	5 John Dalton Street, Manchester. Noah T. Williams	400	None	2l. 2s., 1l. 5s., and 1s.	Transactions of Inst. of Mining Engineers, monthly.
Manchester Microscopical Society, 1880	Grand Hotel, Aytoun Street, Piccadilly, Manchester. William Dixon	162	5s.	6s.	Transactions, annually.
Manchester Statistical Society, 1833	F. Vernon Hansford, 3 York Street, Manchester	154	10s. 6d.	10s. 6d.	Transactions, annually.
Marlborough College Natural History Society, 1864	J. C. Alsop, M.A., Marlborough College	150	1s. 6d.	3s.	Report, annually.
Midland Counties Institution of Engineers, 1871	G. Alfred Lewis, M.A., Midland Road, Derby	360	17. 1s.	2l. 2s. and 1l.	Transactions of Institution of Mining Engineers, monthly.
Museums Association, 1889	E. E. Lowe, B.Sc., Museum and Art Gallery, Leicester	Members (Insts.) 117 Associates (Persons) 116	None	21s.	Museums Journal, monthly.
Norfolk and Norwich Naturalists' Society, 1869	S. H. Long, M.D., 37 St. Giles Street, Norwich	283	None	10s. 6d.	Museums Directory, occasionally.
North of England Institute of Mining and Mechanical Engineers, 1852	Neville Hall, Newcastle-upon-Tyne. Allan Corder	1,214	None	7s. 6d. 25s. and 42s.	Transactions of Inst. of Mining Engineers, monthly.
North Staffordshire Field Club, 1865	H. V. Thompson, Central Technical School, Victoria Road, Stoke-on-Trent	619	5s.	5s.	Transactions and Report, annually.
Northamptonshire Natural History Society and Field Club, 1876	H. N. Dixon, M.A., 17 St. Matthew's Parade, Northampton	220	None	10s.	Journal, quarterly.
Northumberland, Durham, and Newcastle-upon-Tyne, Natural History Society of, 1829	Hancock Museum, Newcastle-upon-Tyne. C. E. Robson and J. A. Richardson	415	None	21s.	Transactions, annually.
Nottingham Naturalists' Society, 1852	Prof. J. W. Carr, M.A., University College, Nottingham	111	2s. 6d.	5s.	Report and Meteorological Observations, annually.
Paisley Philosophical Institution, 1808	J. Gardner, 3 County Place, Paisley	552	5s.	7s. 6d.	Transactions and Proceedings, annually.
Pertshire Society of Natural Science, 1867	Tay Street, Perth. S. T. Ellison	324	None	5s. 6d.	Transactions, biennially.
Rochdale Literary and Scientific Society, 1878	J. Reginald Ashworth, D.Sc., 55 King Street South, Rochdale	227	None	6s.	

## Affiliated Societies—continued.

Full Title and Date of Foundation	Headquarters or Name and Address of Secretary	No. of Members	Entrance Fee	Annual Subscription	Title and Frequency of Issue of Publications
Rochester Naturalists' Club, 1878	Edmund Page, 42 Balmoral Road, Gillingham, Kent	110	None	5s.	'Rochester Naturalists,' quarterly.
Sheffield Naturalists' Club, 1870	O. Bradshaw, and A. Brittain, Public Museum, Sheffield	105	None	5s.	Report, bi-annually; Pro-ceedings, occasionally.
Somersetshire Archaeological and Natural His-tory Society, 1848	The Castle, Taunton. Rev. F. W. Weaver, Rev. E. H. Bates Harbin, O. Tife, and H. St. George Gray.	900	10s. 6d.	Minimum 10s. 6d.	Proceedings, annually.
South Africa, Royal Society of, 1908	G. M. Clark, South African Museum, Cape Town.	207	None	2l.	Transactions, occasionally.
South-Eastern Union of Scientific Societies, 1896	H. Norman Gray, 334 Commercial Road, E.	about 13,000	None	Minimum 5s.	'South-Eastern Naturalist,' annually.
Southport Literary and Philosophical Society, 1880.	W. Allanach, B.Sc., Victoria Science and Art Schools, Southport	186	None	7s. 6d.	Proceedings, occasionally.
South Staffordshire and Warwickshire Institute of Mining Engineers, 1867	G. D. Smith, 3 Newhall Street, Birmingham	160	17. 1s. and 10s. 6d.	42s. and 21s.	Transactions of Inst. of Min-ing Engineers, monthly.
Torquay Natural History Society, 1844	Harford J. Lowe, F.G.S., The Museum, Torquay	171	10s. 6d.	1l. 1s.	Journal, annually.
Tyneside Geographical Society, 1887	Geographical Institute, St. Mary's Place, New-castle-on-Tyne, Herbert Shaw, B.A.	1,000	None	21s. and 10s.	Journal, quarterly.
Vale of Derwent Naturalists' Field Club, 1887	J. E. Patterson, 2 East Avenue, Benton, New-castle-on-Tyne	150	None	2s. 6d.	Transactions, occasionally.
Warrington Literary and Philosophical Society, 1870	J. S. Manson, M.D., 8 Winmarleigh Street, Warrington	137	None	5s.	Proceedings, biennially.
Warwickshire Naturalists' and Archaeologists' Field Club, 1854	Museum, Warwick. O. West, Cross Obearping, Coventry	70	None	5s.	Proceedings, annually.
Woolhope Naturalists' Field Club, 1852	Woolhope Club Room, Free Library, Hereford. T. Hutchinson	178	10s.	10s.	Transactions, occasionally.
Worcestershire Naturalists' Club, 1847	Education Offices, Worcester. F. T. Spackman, F.G.S.	180	10s.	5s.	Transactions, annually.
Yorkshire Geological Society, 1837	Albert Gilligan, B.Sc., The University, Leeds	184	None	13s.	Proceedings, occasionally.
Yorkshire Naturalists' Union, 1861	The Museum, Hull. T. Sheppard, M.Sc., F.G.S.	380	None	10s. 6d.	Transactions, annually.
Yorkshire Philosophical Society, 1821	Museum, York. O. E. Elmhirst	and 3,050 Associates 400	None	2l.	'The Naturalist,' monthly. Report, annually.

## Associated Societies.

Balham and District Antiquarian and Natural History Society, 1887	Miss M. Gardiner, 14a St. James' Road, Wands-worth Common, S.W.	70	None	5s.	Report, annually; Papers, occasionally.
Barrow Naturalists' Field Club and Literary and Scientific Association, 1876	W. L. Page, 5 Cavendish Street, Barrow	202	None	5s. and 2s. 6d.	Report and Proceedings, annually.
Battersea Field Club, 1894	Public Library, Lavender Hill, Battersea, S.W. Miss L. B. Morris	50	2s. 6d.	3s. 6d.	—

Bradford Natural History and Microscopical Society, 1875	Fred. Jowett, 9 Vincent Street, Bradford	15.	4s.	—	—
Bradford Scientific Association, 1875	W. Newbould, 34 Burnett Avenue, Bradford	130	5s. and 2s. 6d.	—	—
Cardiff and District Natural History Society, 1897	Thomas Cooke, 25 Haystead Road, Cardiff, S.E.	57	5s.	—	—
Dunfermline Naturalists' Society, 1902	Robert Somerville, B.Sc., 31 Cameron Street, Dunfermline	170	5s.	—	—
Ealing Scientific and Microscopical Society, 1877	F. McNeil Rushforth, Coley Lodge, 21 Florence Road, Ealing, W.	106	10s. and 2s. 6d.	—	Report and Transactions, annually.
Grimsby and District Antiquarian and Naturalists' Society, 1896	The Museum, Grimsby. A. Bullock (Acting Sec.)	60	2s. 6d.	—	—
Halifax Scientific Society, 1874	J. H. Lamb, 32 Undercliffe Terrace, Halifax	174	2s. 6d.	—	—
Hastings and St. Leonards Natural History Society, 1893	W. de Valier, B.A., 14 St. Matthew's Gardens, St. Leonards-on-Sea	397	3s. 6d.	—	—
Hawick Archaeological Society, 1856	J. J. Vernon, 81 High Street, Hawick	200	2s. 6d.	—	—
Inverness Scientific Society and Field Club, 1875	Thomas Wallace, Elherslie, Inverness	160	5s.	—	—
Lancashire and Cheshire Entomological Society, 1877	Royal Institution, Liverpool. William Mansbridge	90	5s.	—	—
Leeds Naturalists' Club and Scientific Association, 1868	Edward J. T. Ingle, 18 Strattan Street, Leeds	100	5s. and 3s. 6d.	—	—
Letchworth and District Naturalists' Society, 1908	W. Percival Westall, F.L.S., Verulam, The Icknield Way, Letchworth	270	—	—	—
Lewisham Antiquarian Society, 1885	J. W. Brookes, Pembroke Lodge, Slaithwaite Road, Lewisham, S.E.	73	5s.	—	—
Liverpool Microscopical Society, 1868	Royal Institution, Liverpool. R. Croston	63	10s. 6d.	—	—
Llandudno and District Field Club, 1906	L. S. Underwood, Brinkburn, Llandudno	107	5s.	—	—
London : London Natural History Society, 1913	J. Ross, 18 Queen's Grove Road, Chingford, N.E.	230 Members and Assoc.	5s. and 2s. 6d.	—	—
London : South London Entomological and Natural History Society, 1872	Hibernia Chambers, London Bridge, S.E. Stanley Edwards, F.L.S.	180	40s.	—	—
Maidstone and Mid-Kent Natural History and Philosophical Society, 1868	Maidstone Museum. A. Barton and J. W. Bridge	66	10s.	—	—
Newcastle-upon-Tyne, Literary and Philosophical Society of, 1793	Newcastle-upon-Tyne. Alfred Holmes	3,088	17. 1s.	—	—
Preston Scientific Society, 1893	Lecture Hall, 119A Fishergate, Preston. F. Chadderton	420	5s.	—	—
Scarborough Philosophical and Archaeological Society, 1828	A. J. Burniey, 43 Moorland Road, Scarborough	105	None	—	—
School Nature Study Union, 1903	H. E. Turner, 1 Grosvenor Park, Camberwell, S.E.	1,580	None	—	—
Southport Society of Natural Science, 1890	P. H. Christian, 9 Russel Road, Southport	168	5s.	—	—
Teign Naturalists' Field Club, 1888	John S. Amery, Druid, Ashburton, Devon	120	2s. 6d.	—	—
Tunbridge Wells Natural History and Philosophical Society, 1884	Dr. D. Davies, 8 Lonsdale Gardens, Tunbridge Wells	129	10s. 6d. and 5s.	—	—
Warrington Society, 1838	The Old Academy, Bridge Foot, Warrington. James Richardson	103	17. 11s. 6d.	—	—
Watford Camera Club and Photographic Society, 1902	A. Dain, 100 High Street, Watford	50	—	—	—
Wimbledon Natural History Society, 1911	Charles H. Tamm, 12 Kenwyn Road, Wimbledon S.W.	168	1s.	—	—

*Catalogue of the more important Papers, especially those referring to Local Scientific Investigations, published by the Corresponding Societies during the year ending May 31, 1916.*

\* \* This Catalogue contains only the titles of papers published in the volumes or parts of the publications of the Corresponding Societies sent to the Secretary of the Committee in accordance with Rule 2.

*Section A.*—MATHEMATICAL AND PHYSICAL SCIENCE.

- AINSLIE, M. A. An Addition to the Objective. 'Journal Quekett Mic. Club,' XII. 561-576. 1915.
- ALLAN, Dr GEORGE E. Bells and their Tones. 'Proc. Glasgow Royal Phil. Soc.' XLVI. 92-105. 1915.
- ALSOP, J. C. Summary of Meteorological Observations, 1914. 'Report Marl. Coll. N. H. Soc.' No. 63, 57-78. 1915.
- Summary of Meteorological Observations, 1915; and Summary of Fifty Years' Observations. 'Report Marl. Coll. N. H. Soc.' No. 64, 59-84. 1916.
- BASSETT, Rev. H. H. TILNEY. Returns of Rainfall in Dorset in 1914. 'Proc. Dorset N. H. A. F. C.' XXXVI. 195-208. 1915.
- BEATTY, Dr. R. T. The Structure of the Atom. 'Report Belfast N. H. Phil. Soc. 1914-1915,' 5-11. 1915.
- BULLEN, G. E. On Skulls of the Wild Boar from the Roman Level at St. Albans. 'Proc. Herts N. H. S. F. C.' XVI. 49-50. 1916.
- CAMPBELL-BAYARD, FRANCIS, Report of the Meteorological Committee, 1914. 'Trans. Croydon N. H. Sci. Soc.' VIII. 33-42, and Appendices, 64 pp. 1915.
- CANNON, ANNIE J. The Henry Draper Memorial. 'Journal Royal Astr. Soc. of Canada,' IX. 203-215. 1915.
- CANNON, J. B. The Orbit of  $\mu$  Persei. 'Journal Royal Astr. Soc. of Canada,' IX. 388-391. 1915.
- The Orbit of Boss 3323. 'Journal Royal Astr. Soc. of Canada,' IX. 480-485. 1915.
- CHANT, C. A. Stormer's Investigations on the Aurora. 'Journal Royal Astr. Soc. of Canada,' IX. 486-491. 1915.
- COATES, HENRY. Meteorological Observations, Perth, 1914. 'Proc. Perthshire Soc. Nat. Sci.' VI. xevii.-xcv. 1915.
- COLLINS, J. R. Summer Constellations. 'Journal Royal Astr. Soc. of Canada,' IX. 235-238. 1915.
- CRAW, JAMES HEWAT. Account of Rainfall in Berwickshire—Year 1914. 'History Berwickshire Nat. Club,' XXII. 331. 1915.
- Account of Temperature at West Foulden in the Year 1914. 'History Berwickshire Nat. Club,' XXII. 332. 1915.
- CRESSWELL, ALFRED. Records of Meteorological Observations taken at the Observatory, Edgbaston, 1914. 28 pp., with folding tables and diagrams. Birm. and Mid. Inst. Sci. Soc. 1915.
- DAY, WM. H. Lightning: its Nature, and the Efficiency and Methods of Lightning Protection. 'Journal Royal Astr. Soc. of Canada,' X. 121-133. 1916.
- DENNING, W. F. The Great Meteoric Stream of February 9, 1913. 'Journal Royal Astr. Soc. of Canada,' IX. 287-289. 1915.
- The Rotation Period of the Hollow in the Southern Equatorial Belt and of the Great Red Spot in Jupiter. 'Journal Royal Astr. Soc. of Canada,' IX. 333-337. 1915.
- DYSON, F. W. Measurements of the Distances of the Stars. 'Journal Royal Astr. Soc. of Canada,' IX. 407-422. 1915.

- FOX, WILSON LLOYD, and JOSHUA BATH PHILLIPS. Report of the Observatory Committee of the Royal Cornwall Polytechnic Society, with Meteorological Tables for the year 1915, also Additional Meteorological Tables for Falmouth for nine consecutive Lustra, 1871-1915, and Tables of Sea Temperature, with Lustrum Tables. 14 pp. 1916.
- HARPER, W. E. The Orbit of the Spectroscopic Binary 14 Aurigæ. 'Journal Royal Astr. Soc. of Canada,' x. 165-169. 1916.
- HARPER, W. F. Orbit of the Spectroscopic Binary  $\alpha$  Trianguli. 'Journal Royal Astr. Soc. of Canada,' x. 15-18. 1916.
- HOPKINSON, JOHN. The Weather of the Year 1914 in Hertfordshire. 'Trans. Herts N. H. S. F. C.' xvi. 53-68. 1916.
- JACKSON, W. E. W. On the Diurnal Changes in Magnetic Declination at Agincourt, 1902-1912. 'Journal Royal Astr. Soc. of Canada,' ix. 349-353. 1915.
- KLOTZ, OTTO. Location of Epicentres for 1914. 'Journal Royal Astr. Soc. of Canada,' ix. 216-223. 1915.
- Schehallion. 'Journal Royal Astr. Soc. of Canada,' ix. 227-234. 1915.
- The Earthquake of February 18, 1911. 'Journal Royal Astr. Soc. of Canada,' ix. 428-437. 1915.
- Aurora, Earth Currents, and Magnetic Disturbances. 'Journal Royal Astr. Soc. of Canada,' x. 8-14. 1916.
- LAWSON, GRAHAM C. Meteorological Report. 'Trans. N. Staffs F. C.' XLIX. 161-169. 1915.
- LETHABY, JOHN W. The Influence of Astronomy. 'Journal Royal Astr. Soc. of Canada,' ix. 344-348. 1915.
- MCCALLUM, G. H. The Geodetic Survey in British Columbia. 'Journal Royal Astr. Soc. of Canada,' ix. 302-311. 1915.
- MCDIARMID, F. A. The Evolution of Astronomy. (Presidential Address.) 'Journal Royal Astr. Soc. of Canada,' ix. 371-387. 1915.
- Errors in Longitude, Azimuth, and Latitude Determinations—III. 'Journal Royal Astr. Soc. of Canada,' ix. 459-479. 1915.
- MARKHAM, CHRISTOPHER A., and R. H. PRIMAVESI. Meteorological Report. 'Journal Northants N. H. Soc.' xviii. 81-84, 112-115, 135-138. 1915, 1916.
- MITCHELL, S. A. Observations of Meteors needed. 'Journal Royal Astr. Soc. of Canada,' ix. 312-315. 1915.
- MUIR, DR. THOMAS. Note on Hesse's Generalisation of Pascal's Theorem. 'Trans. Royal Soc. of South Africa,' v. 39-43. 1915.
- Ogilvie, NOEL J. Canada-Alaska Boundary Survey. 'Journal Royal Astr. Soc. of Canada,' ix. 290-301. 1915.
- PARKER, T. H. The Orbit of *B. A. C.* 5890. 'Journal Royal Astr. Soc. of Canada,' ix. 338-343. 1915.
- PLASKETT, J. S. Modern Views of the Sun. (Presidential Address.) 'Journal Royal Astr. Soc. of Canada,' x. 101-120. 1916.
- The Spectroscopic Determination of the Solar Rotation at Ottawa. 'Journal Royal Astr. Soc. of Canada,' x. 170-174. 1916.
- RUTHERFORD, JOHN. Weather and other Notes taken at Jardington during 1914. 'Trans. Dumfriesshire and Galloway N. H. A. Soc.' III. (Third Series), 279-287. 1915.
- Astronomical Notes for 1914. 'Trans. Dumfriesshire and Galloway N. H. A. Soc.' III. (Third Series), 288-291. 1915.
- SAMPSON, Prof. R. A. A Census of the Sky. 'Journal Royal Astr. Soc. of Canada,' x. 64-78. 1916.
- THOMAS, DAVID E. (Manchester Geol. Min. Soc.) The Value of the Experimental Fan in the Mining Laboratory. 'Trans. Inst. Min. Eng.' L. 482-491. 1916.
- TURNER, A. B. An Anomaly resulting from the Equation of Time. 'Journal Royal Astr. Soc. of Canada,' x. 175-177. 1916.
- VAN DER LINGEN, J. STEPH. On the Space-Lattice of Liquid Crystals. 'Trans. Royal Soc. of South Africa,' v. 45-51. 1915.
- Note on the Molecules of Liquid Crystals. 'Trans. Royal Soc. of South Africa,' v. 52-54. 1915.
- WALFORD, DR. E. Meteorological Observations in the Society's District, 1914. 'Trans. Cardiff Nat. Soc.' XLVII. 59-77. 1915.
- WATSON, ALBERT D. HORROX. 'Journal Royal Astr. Soc. of Canada,' ix. 271-286. 1915.

- YOUNG, REYNOLD K. The Spectroscopic Binary Orbits. 'Journal Royal Astr. Soc. of Canada,' ix. 224-226. 1915.
- The Spectroscopic Orbit of 12 Lacertæ. 'Journal Royal Astr. Soc. of Canada,' ix. 423-427. 1915.
- The Orbit of the Spectroscopic Binary, A Bootis. 'Journal Royal Astr. Soc. of Canada,' x. 1-7. 1916.
- and W. E. HARPER. The Solar Motion as determined from the Radial Velocities of Spiral Nebulæ. 'Journal Royal Astr. Soc. of Canada,' x. 134-135. 1916.

### Section B.—CHEMISTRY.

- BLATCHFORD, A. S. (N. England Inst. Eng.) The Influence of Incombustible Substances on Coal-dust Explosions. 'Trans. Inst. Min. Eng.' LI. 369-380. 1916.
- EVANS, EDGAR C. (Manchester Geol. Min. Soc.) Carbon Dioxide as an Agent in Extinguishing Mine Fires, with special reference to its application at the Senghenydd Colliery. 'Trans. Inst. Min. Eng.' LI. 209-237. 1916.
- GREENWOOD, H. W., and C. B. TRAVIS. The Mineralogical and Chemical Constitution of the Triassic Rocks of Wirral. Part II. 'Proc. Liverpool Geol. Soc.' XII. 161-188. 1915.
- GREGORY, T. W. D. (N. Staffs Inst. Eng.) Notes on Sampling. 'Trans. Inst. Min. Eng.' XLIX. 498-510. 1915.
- GROOM, Prof. PERCY (Midland Inst. Eng.). Pit Timber and its Preservation. 'Trans. Inst. Min. Eng.' LI. 190-200. 1916.
- HEWITT, H. DIXON. Some Experiments on Patination. 'Proc. Prehistoric Soc. of East Anglia,' II. 45-51. 1915.
- PERKIN, Prof. W. H. The Permanent Fireproofing of Cotton Goods. 'Report Ashmolean Nat. Hist. Soc. 1915,' 29-40. 1916.
- RICE, GEORGE S. American Coal Dust Investigations. 'Trans. Inst. Min. Eng.' XLIX. 721-769. 1915.
- THOMPSON, BEEBY. Peculiarities of Waters and Wells. 'Journal Northants N. H. Soc.' XVIII. 66-79. 1915.

### Section C.—GEOLOGY.

- ARBER, Dr. E. A. NEWELL (S. Staffs & Warw. Inst. Eng.). Studies of the Geology of the Kent Coalfield—Part I. The Coal Measure Records of Four Borings. 'Trans. Inst. Min. Eng.' L. 351-366. 1916.
- The Concealed Oxfordshire Coalfield. 'Trans. Inst. Min. Eng.' L. 373-379. 1916.
- BARKE, F. Geological Report. 'Trans. N. Staffs F. C.' XLIX. 158-160. 1915.
- BELL, ALFRED. A Description of the Sub-Crag Detritus Bed. 'Proc. Prehistoric Soc. of East Anglia,' II. 139-148. 1915.
- BOLTON, HERBERT (Manchester Geol. Min. Soc.). The Fauna and Stratigraphy of the Kent Coalfield. 'Trans. Inst. Min. Eng.' XLIX. 643-698. 1915.
- BREMNER, Dr. ALEXANDER. The Vat near Loch Kinord, Aberdeenshire: Is it a Giant's Kettle (Moulin Pot-hole) or a Stream Pot-hole? 'Trans. Edinburgh Geol. Soc.' x. 326-333. 1916.
- Problems in the Glacial Geology of N.E. Scotland and some fresh facts bearing on them. 'Trans. Edinburgh Geol. Soc.' x. 334-347. 1916.
- BUTCHER, C. H. Palæolithic Implements from Wanstead Park. 'Essex Naturalist,' XVIII. 76-78. 1915.
- CANTRILL, T. C. Geological Notes on the Excavations at the Gatehouse, Llantwit Major, July and August, 1913. 'Trans. Cardiff Nat. Soc.' XLVII. 42-44. 1915.
- COCKIN, G. M. (S. Staffs & Warw. Inst. Eng.) The Basement Rocks of the Bunter, with special reference to the Inundation at the Coppice Colliery. 'Trans. Inst. Min. Eng.' L. 270-274. 1916.
- CRAIG, R. M. Outline of the Geology of Prince Charles Foreland, Spitsbergen. 'Trans. Edinburgh Geol. Soc.' x. 276-288. 1916.
- DAY, T. CUTHBERT. The Cheese Bay Sill, Gullane. 'Trans. Edinburgh Geol. Soc.' x. 249-260. 1916.
- The Breccias of Cheese Bay, and the 'Yellow Conglomerates' of Weak Law. 'Trans. Edinburgh Geol. Soc.' x. 261-275. 1916.

- DEWEY, HENRY. Surface Changes since the Palæolithic Period in Kent and Surrey. 'Proc. Prehistoric Soc. of East Anglia,' II. 107-116. 1915.
- DUNN, JAMES W. Skiddaw and the Rocks of Borrowdale. 'Proc. Liverpool Geol. Soc.' XII. 109-130. 1915.
- EVANS, Dr. J. W. The Determination of Minerals under the Microscope by means of their Optical Characters. 'Journal Quekett Mic Club,' XII. 597-630. 1915.
- FEARNSIDES, Prof. W. G. (Midland Inst. Eng.) Some Effects of Earth-movement on the Coal Measures of the Sheffield District (South Yorkshire and the neighbouring parts of Derbyshire and Nottinghamshire). Part I. 'Trans. Inst. Min. Eng.' L. 573-608. 1916.
- GREENWOOD, H. W. On an Example of the Paragenesis of Marcasite, Wurtzite, and Calcite, and its Significance. 'Proc. Liverpool Geol. Soc.' XII. 131-134. 1915.
- Note on a Boring recently made at Vauxhall Distillery, Vauxhall Road, Liverpool. 'Proc. Liverpool Geol. Soc.' XII. 135-136. 1915.
- GREGORY, Prof. J. W. The Age of Loch Long, and its relation to the Valley System of Southern Scotland. 'Trans. Glasgow Geol. Soc.' xv. 297-312. 1916.
- HARRISON, J. V. The Girvan Landslip. 'Trans. Glasgow Geol. Soc.' xv. 313-314. 1916.
- Notes on the Geology of the East Kilsyth Hills. 'Trans. Glasgow Geol. Soc.' xv. 315-333. 1916.
- HICKLING, Dr. GEORGE (Manchester Geol. Min. Soc.). The Coal Measures of the Croxteth Park Inlier. 'Trans. Inst. Min. Eng.' L. 322-327. 1916.
- The Geological Structure of the South Lancashire Coalfield. 'Trans. Inst. Min. Eng.' L. 328-343. 1916.
- JONES, T. A. Note on the Presence of Tourmaline in Eskdale (Cumberland Granite). 'Proc. Liverpool Geol. Soc.' XII. 137-140. 1915.
- KIDNER, HENRY. Flint Pebbles of Reading Age at Bushey Grove and Oxhey, Watford. 'Proc. Herts N. H. S. F. C.' XVI. 79-80. 1916.
- LOMAX, JAMES (S. Staffs & Warw. Inst. Eng.) The Formation of Coal Seams in the Light of recent Microscopic Investigations. Part I. 'Trans. Inst. Min. Eng.' L. 127-132. 1915; Part II. 'Trans. Inst. Min. Eng.' L. 137-157. 1915.
- LOWE, HARFORD J. Plan of Kent's Cavern. 'Journal Torquay N. H. Soc.' II. 23-24. 1915.
- Relics of the Ice Age in Devon. 'Journal Torquay N. H. Soc.' II. 29-41. 1915.
- On a Fossil Arthropodan Fish, *Homosteus Milleri*, from the Caithness Flagstones found in a Torquay pavement. 'Journal Torquay N. H. Soc.' II. 65. 1916.
- MACNAIR, PETER. The Hurlet Sequence in North Lanarkshire. 'Trans. Glasgow Geol. Soc.' xv. 387-409. 1916.
- MAIDWELL, F. T. Some Sections in the Lower Keuper of Runcorn Hill, Cheshire—II. 'Proc. Liverpool Geol. Soc.' XII. 141-149. 1915.
- Geological Notes on some recent Excavations at West Bank Dock, Widnes. 'Proc. Liverpool Geol. Soc.' XII. 156-160. 1915.
- MARCH, Dr. H. COLLEY, and others. Report on the Excavations at Dewlish, 1914. 'Proc. Dorset N. H. A. F. C.' XXXVI. 209-224. 1915.
- MARTIN, EDWARD A. Brighton's Lost River. 'South-Eastern Naturalist for 1915,' 39-50. 1915.
- NEWLANDS, G. On Volcanic Rocks in the Forest of Birse, Aberdeenshire. 'Trans. Edinburgh Geol. Soc.' x. 308-315. 1916.
- ODLING, M. Second Report of the Fossil Fauna of the Oxford District. 'Report Ashmolean Nat Hist. Soc. 1915,' 51-91. 1916.
- PEACH, ANGUS M'EWEN. The Preglacial Platform and Raised Beaches of Prince Charles Foreland. 'Trans. Edinburgh Geol. Soc.' x. 289-307. 1916.
- RHODES, J. E. WYNFIELD. Microscopic Examinations of Sandstones from the Lower Keuper and Bunter Beds of Runcorn Hill, Cheshire. 'Proc. Liverpool Geol. Soc.' XII. 150-155. 1915.
- (Manchester Geol. Min. Soc.). The Drift Deposits of Prestwich, Manchester and Neighbourhood. 'Trans. Inst. Min. Eng.' XLIX. 424-436. 1915.
- ROGERS, A. W. Geitsi Gubib, an Old Volcano. 'Trans. Royal Soc. of South Africa,' v. 247-258. 1915.
- SHEPPARD, T. Bibliography. Papers and Records relating to the Geology and Palæontology of the North of England (Yorkshire excepted) during 1914 and 1915. 'The Naturalist for 1915,' 271-274, 303-306, 1915; for 1916, 67-74. 1916.
- A Yorkshire Dene Hole. 'The Naturalist for 1915,' 379-381. 1915.

- SHEPPARD, T. Bibliography of Yorkshire Geology. (C. Fox-Strangways Memorial Volume.) 'Proc. Yorkshire Geol. Soc.' xviii, 629 pp. 1915.
- SMELLIE, WILLIAM R. The Igneous Rocks of Bute. 'Trans. Glasgow Geol. Soc.' xv, 334-373. 1916.
- STAINIER, Prof. X. (Manchester Geol. Min. Soc.) The Connexion between the North-Western European Coalfields. 'Trans. Inst. Min. Eng.' li, 99-153. 1916.
- TAIT, D. On Bores for Water and Medicinal Wells in the Wardie Shales, near Edinburgh. 'Trans. Edinburgh Geol. Soc.' x, 316-325. 1916.
- THOMPSON, REEBY. The Town Walls: Where the Stone came from. 'Journal Northants N. H. Soc.' xviii, 103-108. 1915.
- THOMPSON, PERCY G. Notes on the Occurrence of Chalky Boulder Clay at Chingford. 'Essex Naturalist,' xviii, 2-4. 1915.
- TRINDER, (?) Rev. Dr. WILLIAM MARTIN. Edited by Miller Christy. The Chigwell Row Medicinal Springs: a Late Eighteenth Century Account of them. 'Essex Naturalist,' xviii, 60-70. 1915.
- WALLACE, Mrs. Notes on the Petrology of the Agglomerates and Hypabyssal Intrusions between Largo and St. Monans. 'Trans. Edinburgh Geol. Soc.' x, 348-362. 1916.
- WHITEHEAD, W. A. The Formation of a Sandstone. 'Proc. Liverpool Geol. Soc.' xii, 93-108. 1915.
- WOODWARD, Dr. A. SMITH. On a Fossil Arthrodiran Fish, *Homosteus Milleri*, from the Caithness Flagstones, found in a Torquay pavement. 'Journal Torquay N. H. Soc.' ii, 65-69. 1916.
- WRIGLEY, ARTHUR. Notes on the Low-level Gravels of the River Lea and their Palæolithic Implements. 'Essex Naturalist,' xviii, 73-74. 1915.
- Notes on a Fossiliferous Exposure of London Clay at Chingford, Essex. 'Essex Naturalist,' xviii, 74-76. 1915.
- ZEALLEY, A. E. V. The Great Dyke of Norite of Southern Rhodesia: Petrology of the Selukwe Portion. 'Trans. Royal Soc. of South Africa,' v, 1-24. 1915.

#### Section D.—ZOOLOGY.

- ADAMS, J. H. Report of the Malacological Section. 'Report Marl. Coll. N. H. Soc.' No. 64, 40-47. 1916.
- ADKIN, ROBERT. *Colias edusa* in Britain. 'Proc. South London Ent. N. H. Soc. 1914-15,' 22-30. 1915.
- Some Lepidopterous Pupal Habitations and some Reminiscences. 'Proc. South London Ent. N. H. Soc. 1914-15,' 59-69. 1915.
- The Autumn Butterflies at Eastbourne and some other Notes. 'Proc. South London Ent. N. H. Soc. 1915-16,' 62-67. 1916.
- BATTY, E. Some Notes on Micro-Organisms found in the Manchester Corporation Drinking Water. 'Trans. Manchester Mic. Soc. 1914,' 60-68. 1916.
- BAYON, H. *Herpetomonidae* found in *Scatophaga hottentota* and *Chamaeleon pumilus*. 'Trans. Royal Soc. of South Africa,' v, 61-63. 1915.
- BENNETT, W. H. The Coleoptera of the Hastings District. 'Hastings and East Sussex Naturalist,' ii, 185-192. 1915.
- BICKERTON, WILLIAM. Notes on Birds observed in Hertfordshire during the year 1914. 'Trans. Herts N. H. S. F. C.' xvi, 93-107. 1916.
- BLADEN, W. WELLS. Bird Notes (1914), chiefly taken at Stone. 'Trans. N. Staffs F. C.' xlix, 83-86. 1915.
- BLAIR, K. G. Luminous Insects. 'Proc. South London Ent. N. H. Soc. 1914-15,' 31-45. 1915.
- BONAPARTE-WYSE, H. L. New Beetle Records for County Waterford. 'Irish Naturalist,' xxv, 63. 1916.
- Lepidoptera from Killarney. 'Irish Naturalist,' xxv, 73-74. 1916.
- BOOTH, H. B. Notes on the Nesting of the Grasshopper Warbler in the West Riding. 'The Naturalist for 1916,' 167-170. 1916.
- BRAIN, CHAS. K. The *Coccida* of South Africa. 'Trans. Royal Soc. of South Africa,' v, 65-194. 1915.
- BRYCE, DAVID. On Five New Species of the Genus *Habrotrocha*. 'Journal Quekett Mic. Club,' xii, 631-642. 1915



- BUNNETT, E. J. The Maple Aphis and its Dimorphic Larva. 'Proc. South London Ent. N. H. Soc. 1915-16,' 21-24. 1916.
- BURTON, JAMES. On a Species of Aleurodes. 'Journal Quekett Mic. Club,' xii. 7-14. 1916.
- BUTTERFIELD, W. RUSKIN. Notes on the Local Fauna, Flora, &c., for the year 1914. 'Hastings and East Sussex Naturalist,' ii. 170-177. 1915.
- CARROL, C. J. The Crossbill in Co. Tipperary. 'Irish Naturalist,' xxv. 69-72. 1916.
- Ravens in Cos. Waterford and Tipperary. 'Irish Naturalist,' xxv. 75-76. 1916.
- CHARBONNIER, H. J. Notes on the Diptera of Somerset. Part I. 'Proc. Somersetshire Arch. N. H. Soc.' lxi. 189-204. 1916.
- COCKAYNE, DR. E. A. Gynandromorphism. 'Trans. London N. H. Soc. 1914,' 75-85. 1915.
- *Agriades coridon*, the Chalk-hill Blue Butterfly, in Hertfordshire. 'Proc. Herts N. H. S. F. C.' xvi. 81-84. 1916.
- COLGAN, NATHANIEL. On Irish Animal Names. 'Irish Naturalist,' xxiv. 166-169. 1915.
- Observations on Phototropism and the Development of Eye-spots in the Marine Nemertine *Lineus gesserensis*. 'Irish Naturalist,' xxv. 7-42. 1916.
- CORBETT, H. H. Undesirable Insect Aliens at Doncaster. 'The Naturalist for 1915,' 209. 1915.
- DAY, F. H. Cumberland Coleoptera. 'The Naturalist for 1916,' 107-110. 1916.
- DE MULLER, W. Termites. 'Report Hastings and St. Leonards N. H. S., 1914-15,' 28-35. 1915.
- DENDY, PROF. ARTHUR. The President's Address: Some Factors of Evolution in Sponges. 'Journal Quekett Mic. Club,' xiii. 27-46. 1916.
- DIXEY, DR. F. A. Seasonal Dimorphism. 'Proc. South London Ent. N. H. Soc. 1915-16,' 1-14. 1916.
- DREYER, DR. T. F. A Mesostoma from Bloemfontein (*M. karroense*, n. sp.). 'Trans. Royal Soc. of South Africa,' v. 55-59. 1915.
- ELMHIRST, RICHARD. Faunistic Notes: I. Habits of *Cottus bubalis*; II. Records of *Lernæa cyclopterina*, Abnormal *Anas boscas*, *Colymbus arcticus*, *Tetrabothrius macrocephalus*, and *Parachordodes violaceus*. 'Glasgow Naturalist,' vii. 43-47. 1915.
- ELWES, Major E. V. The Life History of a Shore Fly. 'Journal Torquay N. H. Soc.' ii. 3-7. 1915.
- ENOCK, FRED. A New Mymarid from Hastings. 'Hastings and East Sussex Naturalist,' ii. 178-181. 1915.
- FALCONER, WM. The Spiders of Wicken, with description of two new species. 'The Naturalist for 1915,' 201-204, 225-230. 1915.
- Arachnida of the Sawley District. 'The Naturalist for 1915,' 363-364. 1915.
- The Harvestmen and Pseudoscorpions of Yorkshire. 'The Naturalist for 1916,' 103-106, 135-140, 155-158. 1916.
- FINDON, HUGH. The Problem of Terrestrial and Fluvial Shell-fish. 'South-Eastern Naturalist for 1915,' 32-38. 1915.
- FORDHAM, W. J. Yorkshire Coleoptera in 1914. 'The Naturalist for 1915,' 198-200. 1915.
- FORTUNE, R. The Protection of Wild Life in Yorkshire. (Presidential Address to the Yorkshire Naturalists' Union.) 'The Naturalist for 1916,' 53-59, 92-95, 124-131, 151-154. 1916.
- FOSTER, NEVIN H. Natural History Notes from Carlingford, Co. Louth. 'Irish Naturalist,' xxiv. 101-104. 1915.
- On the Distribution of the Symphyla in Ireland as at present known. 'Irish Naturalist,' xxiv. 174-175. 1915.
- FRIEND, Rev. HILDERIC. Notes on Irish Oligochaets. 'Irish Naturalist,' xxv. 22-27. 1916.
- Are White Worms injurious? 'Irish Naturalist,' xxv. 44-47. 1916.
- GARNETT, HENRY. A Note on *Simulium*. 'Trans. Manchester Mic. Soc. 1914,' 37-40. 1916.
- GEMMILL, DR. JAMES F. The Hydroid Stage of *Lar sabellarum*, Gosse (new Firth of Clyde Record). 'Glasgow Naturalist,' vii. 1-2. 1916.

- GIBBS, A. E. *Rhyssa persuasoria*, the Ichneumon of the Giant Saw-fly, *Sirex gigas*, in Hertfordshire. 'Trans. Herts N. H. S. F. C.' xvi. 39-40. 1916.
- GREER, THOMAS. Lepidoptera from County Tyrone. 'Irish Naturalist,' xxv. 56-61. 1916.
- H., L. E. A Cumberland Nature Reserve. 'The Naturalist for 1915,' 187-191, 238-243. 1915.
- HALBERT, J. N. Some Recent Records of Irish Insects, 'Irish Naturalist,' xxiv. 157-165. 1915.
- HALLET, H. M. Entomological Notes, 1914. 'Trans. Cardiff Nat. Soc.' XLVII. 54-58. 1915.
- HAMMOND, L. F. Description of an Experiment in Variable Protective Colouring in the Pupæ of *Pieris Brassicæ*. 'Trans. Croydon N. H. Sci. Soc.' VIII. 5-11. 1915.
- HARDY, G. HURLSTONE. The Fly-Peril and its Cure. 'South-Eastern Naturalist for 1915,' 76-84. 1915.
- HARRIS, G. T. The Collection and Preservation of Desmids. 'Journal Quekett Mic. Club,' XIII. 15-26. 1916.
- HARRISON, J. W. HESLOP. The Psyllidae of the Cleveland. 'The Naturalist for 1915,' 400-401. 1915.
- *Psylla bagnalli* (Harrison): A New Species of Psyllid. 'The Naturalist for 1916,' 62-63. 1916.
- *Aleuropteryx lutea* (Wallengren): A Neuropteron new to Britain. 'The Naturalist for 1916,' 97-98. 1916.
- The Geographical Distribution of the Moths of the Sub-Family Bistoninae. 'The Naturalist for 1916,' 163-166. 1916.
- HAUGHTON, S. H. On Some Dinosaur Remains from Bushmanland. 'Trans. Royal Soc. of South Africa,' v. 259-264. 1915.
- HOLLIS, W. H. On making Sections of Shells, 'Journal Northants N. H. Soc.' XVIII. 109-110. 1915.
- HOLT, A. E. Report of the Entomological Section. 'Report Marl. Coll. N. H. Soc.' No. 64, 34-39. 1916.
- HULL, Rev. J. E. Acari from Birds' Nests, with Description of a New Species. 'The Naturalist for 1915,' 398-399. 1915.
- JOHNSON, Rev. W. F. Ichneumonidae from the North of Ireland. 'Irish Naturalist,' xxiv. 130-133. 1915.
- Ichneumonidae and Braconidae from Counties Armagh and Donegal. 'Irish Naturalist,' xxv. 17-21. 1916.
- *Hymenoptera aculeata* in the Counties of Armagh and Donegal. 'Irish Naturalist,' xxv. 61-62. 1916.
- KANE, W. F. DE V. The Crossbill and its Diet. 'Irish Naturalist,' xxv. 53-54. 1916.
- KIRKPATRICK, T. W. Report of the Diptera Section. 'Report Marl. Coll. N. H. Soc.' No. 63, 37-43. 1915.
- LINDER, ERNEST, and CHARLES KEY. Note on Leaf-folding Caterpillars. 'Essex Naturalist,' XVIII. 70-73. 1915.
- LUCAS, W. J. British Long-horned Grasshoppers. 'Proc. South London Ent. N. H. Soc. 1914-15,' 49-58. 1915.
- British Cockroaches. 'Proc. South London Ent. N. H. Soc. 1915-16,' 29-40. 1916.
- British Crickets. 'Proc. South London Ent. N. H. Soc. 1915-16,' 50-54. 1916.
- MASEFIELD, J. R. B. Annual Address: Staffordshire Mammals. 'Trans. N. Staffs F. C.' XLIX. 44-55. 1915.
- Staffordshire Vertigos. 'Trans. N. Staffs F. C.' XLIX. 80-82. 1915.
- Zoological Report. 'Trans. N. Staffs F. C.' XLIX. 148-154. 1915.
- MEARES, C. S. British Breeding Ducks. 'Trans. London N. H. Soc. 1914,' 48-69. 1915.
- MEYRICK, E. Report of the Entomological Section. 'Report Marl. Coll. N. H. Soc.' No. 63, 31-36. 1915.
- Ornithological List. 'Report Marl. Coll. N. H. Soc.' No. 63, 44-48. 1915.
- MILNE, W. On the Bdelloid Rotifera of South Africa. Part I. 'Journal Quekett Mic. Club,' XIII. 47-84. 1916.
- MOFFAT, C. B. The Crossbill and its Diet. 'Irish Naturalist,' xxv. 1-6. 1916.
- MOSLEY, CHARLES. Moulting of *Oniscus asellus* Linné. 'The Naturalist for 1915,' 284-285. 1915.

- NELSON, EDWARD M. Various Insect Structures. 'Journal Quekett Mic. Club,' XII. 593-596. 1915.
- NEWMAN, L. W. Notes on Breeding and Collecting the 'Sesia.' 'Trans. London N. H. Soc. 1914,' 43-48. 1915.
- OLDHAM, CHARLES. A Day with the Birds in North-West Hertfordshire. 'Proc. Herts N. H. S. F. C.' XVI. 51-52. 1916.
- OVERTON, H. Holocene Mollusca of Letocetum. 'Trans. N. Staffs F. C.' XIX. 87-91. 1915.
- PENTLAND, G. H. Notes on a Decoy in the County of Louth. 'Irish Naturalist,' XXIV. 209-211. 1915.
- PERKINS, DR. R. C. L. Observations on the Study and Collecting of Insects in South Devon. 'Journal Torquay N. H. Soc.' II. 8-11. 1915.
- List of a Collection of Hymenoptera made, arranged, and presented to the Natural History Museum by Dr. Perkins. 'Journal Torquay N. H. Soc.' II. 12-16. 1915.
- Local Hymenoptera. 'Journal Torquay N. H. Soc.' II. 75-77. 1916.
- PHILLIPS, R. A. The Non-Marine Mollusca of South Galway. 'Irish Naturalist,' XXIV. 137-150. 1915.
- PLATT-BARRETT, J. The European Species of the Genus *Melanargia*. 'Proc. South London Ent. N. H. Soc. 1915-16,' 55-61. 1916.
- PROGER, T. W., and D. R. PATERSON. Ornithological Notes, 1914. 'Trans. Cardiff Nat. Soc.' XLVII. 45-53. 1915.
- PROUT, LOUIS B. Presidential Address. 'Trans. London N. H. Soc. 1914,' 31-40. 1915.
- RENNIE, WILLIAM. The Mute Swan (*Cygnus olor*) at Possil Marsh. 'Glasgow Naturalist,' VII. 79-88. 1915.
- RHODES, F. The Terrestrial Isopoda (Woodlice) of Yorkshire. 'The Naturalist for 1915,' 99-102, 121-123. 1916.
- RICHARDSON, NELSON M. Anniversary Address. 'Proc. Dorset N. H. A. F. C.' XXXVI. lii-lxxiv. 1915.
- RITCHIE, JOHN, jun. A Contribution to the Parasitic Fauna of the West of Scotland. 'Glasgow Naturalist,' VII. 33-42. 1915.
- ROGERS, A. W. The Occurrence of Dinosaurs in Bushmanland. 'Trans. Royal Soc. of South Africa,' v. 265-272. 1915.
- ROSS, ALEXANDER. Some Additional Notes on the Birds of Islay. 'Glasgow Naturalist,' VII. 97-101. 1915.
- SANO, CONSTANT. On the Metamorphosis of *Geotrupes stercorarius*, L. 'Proc. South London Ent. N. H. Soc. 1915-16,' 25-28. 1916.
- SCHARFF, DR. R. F. The Long-finned Bream (*Brama longipinnis*, Lowe). An Addition to the Britannic Fauna. 'Irish Naturalist,' XXIV. 97-98. 1915.
- Notes on Irish Sharks. 'Irish Naturalist,' XXIV. 98-100. 1915.
- On the Irish Names of Birds. 'Irish Naturalist,' XXIV. 109-129. 1915.
- The Clare Island Survey. 'Irish Naturalist,' XXIV. 177-187. 1915.
- Some Irish Bird-Names heard on Rathlin Island. 'Irish Naturalist,' XXIV. 211-213. 1915.
- SCHLESCH, HANS. Notes on Some Danish Mollusca. 'The Naturalist for 1916,' 61. 1916.
- SELOUS, EDMUND. A Diary of Ornithological Observations in Brittany. 'The Naturalist for 1915,' 193-197. 1915.
- Observations on the Grey Seal. 'The Naturalist for 1915,' 217-221, 253-257, 281-284, 358-362. 1915.
- SICH, ALFRED. Life Cycle of *Tortrix viridana*, L. 'Proc. South London Ent. N. H. Soc. 1915-16,' 15-20. 1916.
- Limacology. 'Proc. South London Ent. N. H. Soc. 1915-16,' 41-49. 1916.
- SPINK, S. C. A Sketch of the Invertebrate Seashore Fauna of Brighton. 'Selborne Magazine,' XXVII. 14-17, 28-31. 1916.
- STAINFORTH, T. The Guests of Yorkshire Ants. 'The Naturalist for 1915,' 385-397. 1915.
- Notes on some Yorkshire Coleoptera. 'The Naturalist for 1915,' 402-404. 1915.
- STENTON, RUPERT. Mendelism and Selection in Animal Breeding. 'Journal Torquay N. H. Soc.' II. 99-109. 1916.

- STURT, H. H. Report of the Ornithological Section. 'Report Marl. Coll. N. H. Soc.' No. 64, 48-51. 1916.
- THOMSON, Prof. J. ARTHUR. The Web of Life. 'Report Belfast N. H. Phil. Soc. 1914-15,' 63-67. 1915.
- TICEHURST, NORMAN F. A hitherto unrecorded Duck Decoy at Crowhurst. 'Hastings and East Sussex Naturalist,' II. 149-153. 1915.
- TOMLIN, J. R. LE B. The Coleoptera of Glamorgan. 'Trans. Cardiff Nat. Soc.' XLVII. 13-33. 1915.
- W., W. E. L. Natural History of Sawley and Eavestone, near Ripon. 'The Naturalist for 1915,' 206-208, 231-237. 1915.
- WALKER, J., and H. LUPTON. Notes on Local Lepidoptera. 'Journal Torquay N. H. Soc.' II. 25-28. 1915.
- WALKER, J. J. Interim Report on Coleoptera. 'Report Ashmolean Nat. Hist. Soc. 1915,' 49. 1916.
- WALLIS, ALBERT. The Snail and its Name. 'Journal Northants N. H. Soc.' XVIII. 117-128. 1916.
- WHEELER, Rev. G. The Genus *Melitæa*. 'Proc. South London Ent. N. H. Soc. 1914-15,' 1-16. 1915.
- WILLIS, H. G. Spiders. 'Trans. Manchester Mic. Soc. 1914,' 50-59. 1916.
- WORTHAM, Miss W. H. The Botany of Puffin Island. 'Proc. Llandudno F. C.' VII. 15-20. 1915.
- YATES, HARRY. *Peripatoides orientalis*. 'Trans. Manchester Mic. Soc. 1914,' 42-49. 1916.

#### Section E.—GEOGRAPHY.

- BARNARD, A. SEDGWICK. Glimpses of Ceylon. 'Journal Manchester Geog. Soc.' XXXI. 36-51. 1916.
- COPLAND-CRAWFORD, W. E. B. Nigeria. 'Journal Manchester Geog. Soc.' XXXI. 1-15. 1916.
- FAGG, C. C. The Regional Survey and Local Natural History Societies. 'South-Eastern Naturalist for 1915,' 21-31. 1915.
- FALCONER, Dr. J. D. The Geographical Factor in Ancient Colonisation. 'Proc. Glasgow Royal Phil. Soc.' XLVI. 125-135. 1915.
- HUTCHESON, J. Geography: its Field, its Fascination, and its Future. 'Journal Manchester Geog. Soc.' XXX. 145-153. 1915.
- LYONS, Major H. G. The Importance of Geographical Research. 'Journal Manchester Geog. Soc.' XXXI. 52-70. 1916.
- MELLOR, E. W. The Home of the Rajputs. 'Journal Manchester Geog. Soc.' XXX. 105-124. 1915.
- PERCIVAL, F. G. Venezuela. 'Journal Manchester Geog. Soc.' XXXI. 16-18. 1916.
- SHIRLEY, G. W. Notes on the Topography of Dumfries. 'Trans. Dumfriesshire and Galloway N. H. A. Soc.' III. (Third Series), 166-213. 1915.
- WESTON, Rev. WALTER. Recent Explorations in the Japanese Alps. 'Journal Manchester Geog. Soc.' XXXI. 23-35. 1916.
- WHYMAN, T. The Effect of Geographical Features on the War at Sea. 'Journal Manchester Geog. Soc.' XXXI. 19-22. 1916.
- WILMORE, Dr. ALBERT. Belgium: the Battleground of Europe. 'Journal Manchester Geog. Soc.' XXX. 125-129. 1915.

#### Section F.—ECONOMIC SCIENCE AND STATISTICS.

- CHATER, C. W. (N. England Inst. Eng.) Mining in Burma. Part I. 'Trans. Inst. Min. Eng.' XLIX. 628-639. 1915.
- DOYLE, DANIEL S. Housing. 'Journal Stat. Soc. Ireland,' XIII. 255-268. 1915.
- FLETCHER, LEONARD R. (Manchester Geol. Min. Soc.) Presidential Address: The War and the Coal Mining Industry. 'Trans. Inst. Min. Eng.' L. 286-294. 1916.
- HESKETH, W. T. The Influence of Sun-spots on Prices. Professor Jevons's Theories explained. 'Trans. Manchester Stat. Soc. 1914-15,' 13-34. 1915.
- NIMMO, ADAM. The Working of Conciliation Boards in the Coal Trade, with special reference to Scotland. 'Proc. Glasgow Royal Phil. Soc.' XLVI. 136-145. 1915.

- OLDHAM, Prof. C. H. The Economic Interests involved in the present War. 'Journal Stat. Soc. Ireland,' XIII. 269-280. 1915.
- OLDHAM, CHARLES. Two Ancient East Anglian Industries: Cultivation and Manufacture of Woad and Manufacture of Gun-flints. 'Trans. Herts N. H. S. F. C.' XVI. 37-38. 1916.
- SMART, Prof. WILLIAM. The Economic Dislocation of the War. 'Proc. Glasgow Royal Phil. Soc.' XLVI. 16-36. 1915.
- WELTON, THOMAS A. The Occupations of the People of England and Wales in 1911 from the point of view of Industrial Developments. 'Trans. Manchester Stat. Soc. 1914-15,' 47-170. 1915.
- WILLIAMS, ARNOLD. Belgium, the Land of Art: its Economic and Political History. 'Journal Manchester Geog. Soc.' XXX. 130-144. 1915.
- YOUNG, J. DENHOLM. The Transport of Merchandise by Sea and by Land; some Figures and Comparisons. 'Trans. Liverpool Eng. Soc.' XXXVI. 8-20. 1915.

### Section G.—ENGINEERING.

- ABELL, W. S. Ship Casualties. 'Trans. Liverpool Eng. Soc.' XXXVI. 159-175. 1915.
- BLACK, JAMES (Min. Inst. Scotland). Forming a Shaft-pillar in Thin Seams. 'Trans. Inst. Min. Eng.' L. 449-456. 1916.
- BRIGGS, HENRY (Min. Inst. Scotland). Rescue-station Organization: the Resident Brigade System *versus* the System of Non-resident Brigades. 'Trans. Inst. Min. Eng.' XLIX. 519-525. 1915.
- A Method for the Rapid Estimation of Oxygen and Blackdamp in the Air of Safety-lamp Mines. 'Trans. Inst. Min. Eng.' LI. 169-186. 1916.
- BRODIE, JOHN A. Notes on the Improvement of Local Means of Communication. 'Trans. Liverpool Eng. Soc.' XXXVI. 233-249. 1915.
- COPPERTHWAITTE, W. C. Subaqueous Tunnelling with a Shield. 'Trans. Liverpool Eng. Soc.' XXXVI. 29-48. 1915.
- DEAN, SAMUEL (N. England Inst. Eng.). Modern American Coal-Mining Methods, with some Comparisons. 'Trans. Inst. Min. Eng.' L. 179-211. 1916.
- DICKINSON, HAROLD. Some Notes on the Liverpool Electric Supply Undertaking. 'Trans. Liverpool Eng. Soc.' XXXVI. 207-224. 1915.
- DVORKOVITZ, Dr. PAUL. Boring and Drilling on Oilfields. 'Trans. Inst. Min. Eng.' XLIX. 705-714. 1915.
- ELLISON, CHARLES CHETWYND (Midland Inst. Eng.). Presidential Address [The Position of the Mining Industry]; Notes on the Uses and Markets of Bye-Products obtained from Coke Ovens. 'Trans. Inst. Min. Eng.' L. 501-519. 1916.
- GIBSON, JOHN (N. England Inst. Eng.). The Logic of Trams. 'Trans. Inst. Min. Eng.' LI. 72-84. 1916.
- GILLIEAUX, MARCEL (Min. Inst. Scotland). Lining Shafts with Concrete Z-Blocks. 'Trans. Inst. Min. Eng.' L. 51-59. 1915.
- GIVEN, ERNEST C. Inaugural Address [Engineers and the War.]. 'Trans. Liverpool Eng. Soc.' XXXVI. 1-6. 1915.
- GREEN, HAROLD (Manchester Geol. Min. Soc.). Visual Signalling. 'Trans. Inst. Min. Eng.' L. 472-478. 1916.
- GREENER, T. Y. (N. England Inst. Eng.) Presidential Address: The Manufacture of Coke in Bye-product Ovens. 'Trans. Inst. Min. Eng.' L. 164-177. 1915.
- HALBAUM, H. W. G. (N. England Inst. Eng.) The Winding-drums of Practice and of Theory; with Notes on Factors of Safety and Economy of Winding-ropes. 'Trans. Inst. Min. Eng.' XLIX. 557-597. 1915.
- HIRSCH, HIRAM H. (N. England Inst. Eng.) The Hirsch Portable Electric Lamp. 'Trans. Inst. Min. Eng.' LI. 61-71. 1916.
- HUNTER, SHERWOOD (Manchester Geol. Min. Soc.). Economies in Coal-washing. 'Trans. Inst. Min. Eng.' LI. 268-281. 1916.
- MACDONALD, Rt. Hon. Sir JOHN H. A. Power Traction in War. 'Proc. Glasgow Royal Phil. Soc.' XLVI. 136-145. 1915.
- MARTIN, H. E. LANCE. Some Experiments with Reinforced Materials examined by aid of Plane Polarised Light. 'Trans. Liverpool Eng. Soc.' XXXVI. 59-86. 1915.
- MAVOR, SAM. Compressed Air for Coal Cutters. 'Trans. Inst. Min. Eng.' L. 625-704. 1916.

- MILLS, MANSFELDT HENRY. Gas-producers at Collieries for Obtaining Power and Bye-products from Unsaleable Fuel. 'Trans. Inst. Min. Eng.' L. 723-748. 1916.
- NISBET, JAMES (Min. Inst. Scotland). The Sinking and Equipment of a Circular Shaft. 'Trans. Inst. Min. Eng.' LI. 305-338. 1916.
- PATON, J. DRUMMOND (S. Staffs & Warw. Inst. Eng.). Modern Developments in Hydraulic Stowing, with Suggestions for its Application in the Staffordshire and District Coalfield, and the Recovery of Abandoned Coal. 'Trans. Inst. Min. Eng.' XLIX. 470-484. 1915.
- SIMONS, W. (N. Staffs Inst. Eng.) Notes on the Specification of Iron and Steel suitable for Colliery Use. 'Trans. Inst. Min. Eng.' LI. 245-260. 1916.
- SNOW, R. COLIN (Midland Counties Inst. Eng.). The Adlington Signal Apparatus. 'Trans. Inst. Min. Eng.' XLIX. 463-466. 1915.
- STRACHAN, J. (Midland Counties Inst. Eng.) The B-well Signal Indicator. 'Trans. Inst. Min. Eng.' XLIX. 467. 1915.
- STRZELECKI, PERCY. List of Fatal and Non-fatal Explosions of Fire-damp or Coal-dust, and Barometer, Thermometer, etc., Readings for the year 1914. 'Trans. Inst. Min. Eng.' XLVIII. 679-685. 1915.
- THOMAS, TOM R. Gyroscopic Applications, with Demonstrations. 'Trans. Liverpool Eng. Soc.' XXXVI. 99-119. 1915.
- THORNTON, Prof. W. M. A New Battery Signalling Bell. 'Trans. Inst. Min. Eng.' L. 19-26. 1915.
- WALL, A. T. Some Considerations in the Design of Channel Steamers. 'Trans. Liverpool Eng. Soc.' XXXVI. 125-144. 1915.
- WALSHE, J. M. (N. Staffs Inst. Eng.) High-speed Air Compressors for Mining Work. 'Trans. Inst. Min. Eng.' LI. 2-23. 1916.
- WILKIE, JAMES B. Hot Bulb Engines and their Application. 'Trans. Liverpool Eng. Soc.' XXXVI. 180-198. 1915.

### Section H.—ANTHROPOLOGY.

- ALSO, J. C. Anthropometrical Report. 'Report Marlb. Coll. N. H. Soc.' No. 64, 85-112. 1916.
- CATON, LOUISA L. F. Spade-work in North-West Suffolk. 'Proc. Prehistoric Soc. of East Anglia,' II. 35-38. 1915.
- CHANDLER, R. H. Implements of Les Eyzies-Type and a Working Floor in the River Cray Valley. 'Proc. Prehistoric Soc. of East Anglia,' II. 80-98. 1915.
- CLARKE, W. G. A Prehistoric Flint-Pit at Ringland. 'Proc. Prehistoric Soc. of East Anglia,' II. 148-151. 1915.
- CRAW, JAMES HEWAT. An Account of the Excavation of Two Cairns of the Bronze Age at Foulden Hagg. 'History Berwickshire Nat. Club,' XXII. 282-294. 1915.
- CROOKE, WILLIAM. The Transmission of Culture. 'Proc. Cheltenham Nat. Sci. Soc.' III. (N.S.), 13-21. 1915.
- DAWSON, CHARLES. The Piltdown Skull (*Eoanthropus Dawsoni*). 'Hastings and East Sussex Naturalist,' II. 182-184. 1915.
- HEWITT, H. DIXON. A Neolithic Site near Thetford. 'Proc. Prehistoric Soc. of East Anglia,' II. 42-45. 1915.
- KENDALL, Rev. H. G. O. Middle Glacial and Pre-Crag Implements in South Norfolk. 'Proc. Prehistoric Soc. of East Anglia,' II. 31-35. 1915.
- Flint Implements in Cornwall. 'Proc. Prehistoric Soc. of East Anglia,' II. 58-59. 1915.
- Some Palæolithic Pits and Periods in Hertfordshire, etc. 'Proc. Prehistoric Soc. of East Anglia,' II. 135-139. 1915.
- LAYARD, NINA F. 'Coast Finds' by Major Moore at Felixstowe Ferry. 'Proc. Prehistoric Soc. of East Anglia,' II. 132-134. 1915.
- LEBOUR, NONA. Amber and Jet in Ancient Burials: their Significance. 'Trans. Dumfriesshire and Galloway N. H. A. Soc.' III. (Third Series), 106-120. 1915.
- LOWE, HARFORD J. The Stone Implements from the Breccia of Kent's Cavern. 'Journal Torquay N. H. Soc.' II. 80-87. 1916.
- MEDLEY, Prof. DUDLEY J. The War and the Races of Europe. 'Proc. Glasgow Royal Phil. Soc.' XLVI. 1-15. 1915.
- MEYRICK, E. Anthropometrical Report. 'Report Marlb. Coll. N. H. Soc.' No. 63, 79-102. 1915.

- MOIR, J. REID. On the Further Discoveries of Flint Implements of Man beneath the Base of the Red Crag of Suffolk. (Presidential Address.) 'Proc. Prehistoric Soc. of East Anglia,' II. 12-31. 1915.
- A Series of Mineralised Bone Implements of a Primitive Type from below the Base of the Red and Coralline Crags of Suffolk. 'Proc. Prehistoric Soc. of East Anglia,' II. 116-131. 1915.
- NUTTALL, DR. T. E. The Occurrence of Palæoliths in North-East Lancashire. 'Proc. Prehistoric Soc. of East Anglia,' II. 61-71. 1915.
- PEAKE, A. E. A Cave Site at Nettlebed, S. Oxon. 'Proc. Prehistoric Soc. of East Anglia,' II. 71-80. 1915.
- PÉRINGUEY, DR. L. Presidential Address: The Bushman as a Palæolithic Man. 'Trans. Royal Soc. of South Africa,' V. 225-236. 1915.
- SALEEBY, DR. C. W. The Longest Price of War. 'Trans. Manchester Stat. Soc. 1914-15,' 1-12. 1915.
- SMITH, REGINALD A. High-Level Finds in the Upper Thames Valley. 'Proc. Prehistoric Soc. of East Anglia,' II. 99-107. 1915.
- SOILY, REV. H. SHAEN. Early Man in Dorset. 'Proc. Dorset N. H. A. F. C.' XXXVI. 28-40. 1915.
- TOMES, DR. CHARLES S. An Ancient Interment at Mannington. 'Proc. Prehistoric Soc. of East Anglia,' II. 152-153. 1915.
- WARREN, S. HAZZLEDINE. The Dating of Early Human Remains. (Presidential Address.) 'Essex Naturalist,' XVIII. 40-59. 1915.
- WILSON, EDWARD T. President's Address: Notes on the Long Barrow Race beyond the Cotteswolds. 'Proc. Cheltenham Nat. Sci. Soc.' III. (N.S.), 1-5. 1915.

### Section I.—PHYSIOLOGY.

- ELLIOTT, O. T. Germ Diseases and Immunity. 'Trans. Leicester Lit. and Phil. Soc.' XIX. 5-16. 1915.
- HALDANE, DR. J. S. Presidential Address: The Place of Biology in Human Knowledge and Endeavour. 'South-Eastern Naturalist for 1915,' 1-20. 1915.
- MCCORMICK, MICHAEL (Min. Inst. Scotland). An Auxiliary Aid Outfit for Attachment to Self-contained Rescue Apparatus. 'Trans. Inst. Min. Eng.' XLIX. 526-530. 1915.
- MCWEENEY, PROF. E. J. On Immunity against Infectious Disease, with special reference to Anti-Typhoid Inoculation. 'Journal Stat. Soc. Ireland,' XIII. 231-254. 1915.

### Section K.—BOTANY.

- ADAMS, J. H. Report of the Botanical Section. 'Report Marl. Coll. N. H. Soc.' No. 64, 24-33. 1916.
- ALLEN, W. B. Mycetozoa collected at the Spring Foray at Baslow, May 22-25, 1915. 'Trans. British Mycological Soc.' V. 192-195. 1916.
- ANDERSON, ADAM. List of less common Plants in the Area of the Club, with Localities and References. 'History Berwickshire Nat. Club,' XXII. 227-272. 1915.
- BARCLAY, W. Opening Address. 'Proc. Perthshire Soc. Nat. Sci.' VI. lxxv.-lxxiii. 1915.
- Annual Address: Notes on Roses. 'Proc. Perthshire Soc. Nat. Sci.' VI. lxxxii.-lxxxix. 1915.
- BATES, GEORGE F. Pollen. 'Trans. Perthshire Soc. Nat. Sci.' VI. 62-70. 1915.
- BEDFORD, E. J. The Order Orchidaceæ in Sussex. 'South-Eastern Naturalist for 1915,' 72-75. 1915.
- BENNETT, ARTHUR. Notes on 'Additions to the List of Perthshire Plants since the Publication of Dr. White's Flora.' 'Proc. Perthshire Soc. Nat. Sci.' VI. lxxx.-lxxxii. 1915.
- BICKERTON, WILLIAM. A Protest against the Eradication of Poisonous Plants in the Watford District. 'Proc. Herts N. H. S. F. C.' XVI. 69-71. 1916.
- BOULGER, PROF. G. S. The Connection of Kew with the History of Botany. 'South-Eastern Naturalist for 1915,' 61-71. 1915.
- BOYD, D. A. Notes on Microfungi observed in the Lochlomond District. 'Glasgow Naturalist,' VII. 3-8. 1916.

- BOYD, D. A. Records of Microfungi for the Lochlmond District. 'Glasgow Naturalist,' VII. 9-16. 1916.
- Some Recent Additions to the List of Microfungi of the Clyde Area. 'Glasgow Naturalist,' VII. 77-79. 1916.
- BROWN, Dr. ROBERT. Alpine Louseworts (Pedicularis). 'Glasgow Naturalist,' VII. 51-56. 1915.
- BULLEN, G. E. On the Cultivation of Hydrophilous Plants on a Dry Soil. 'Proc. Herts N. H. S. F. C.' XVI. 73-74. 1916.
- BURTON, JAMES. *Hydrodictyon reticulatum*. 'Journal Quekett Mic. Club,' XII. 587-592. 1915.
- CHEETHAM, CHRIS. A. *Grimmia Hartmani* Schp.: an Addition to the Yorkshire Moss Flora. 'The Naturalist for 1915,' 192. 1915.
- CHESTER, GEORGE. Plant Notes, 1914-1915. 'Journal Northants N. H. Soc.' XVIII. 129-131. 1916.
- COATES, HENRY. The Evolution of Plant Life on a Haughland. 'Trans. Perthshire Soc. Nat. Sci.' VI. 33-43. 1915.
- CRYER, JOHN. Yorkshire Hawkweeds. 'The Naturalist for 1916,' 59-60. 1916.
- CURTIS, W. PARKINSON. Phenological Report on First Appearances of Birds, Insects, &c., and First Flowering of Plants in Dorset during 1914. 'Proc. Dorset N. H. A. F. C.' XXXVI. 106-147. 1915.
- DOIDGE, Dr. ETHEL M. Some Notes on the South African *Erysiphaceæ*. 'Trans. Royal Soc. of South Africa,' V. 237-246. 1915.
- DRUCE, G. CLARIDGE. Botanical Notes. 'Report Ashmolean Nat. Hist. Soc. 1915,' 41-43. 1916.
- ELLIS, JOHN W. New British Fungi. 'Trans. British Mycological Soc.' V. 228-231. 1916.
- ELWES, Major E. V. Notes on the Society's Botanical Collections. 'Journal Torquay N. H. Soc.' II. 70-74. 1916.
- EVANS, I. B. POLE. Descriptions of some New Aloes from the Transvaal. 'Trans. Royal Soc. of South Africa,' V. 25-37. 1915.
- FINCH, W. COLES. Some Local Poisonous Plants. 'Rochester Naturalist,' V. 454-460. 1915.
- HAGGART, D. A. Botanical Notes: Appin, Fortingall, Schiehallion, and Ben Lawers. 'Trans. Perthshire Soc. Nat. Sci.' VI. 44-55. 1915.
- HARRIS, G. T. A Note on the Slides of Fissidentaceæ in the Q.M.C. Cabinet. 'Journal Quekett Mic. Club,' XII. 581-584. 1915.
- HARRISON, J. W. HESLOP. The Wild Roses of Durham. 'The Naturalist for 1916,' 9-13. 1916.
- HEEDEN, THOMAS. The Lichen Flora of Harden Beck Valley. 'The Naturalist for 1916,' 132-134, 159-162. 1916.
- HILTON, A. E. Further Notes on the Cultivation of Plasmodia of *Badhamia utricularis*. 'Journal Quekett Mic. Club,' XII. 585-586. 1915.
- On the Formation of Sporangia in the Genus *Stemonitis*. 'Journal Quekett Mic. Club,' XIII. 1-6. 1916.
- HOPKINSON, JOHN. Report on the Phenological Observations in Hertfordshire for the year 1914. 'Trans. Herts N. H. S. F. C.' XVI. 85-92. 1916.
- LARTER, Miss C. ETHELINDA. Devon Pansies. 'Journal Torquay N. H. Soc.' II. 17-22. 1915.
- LEE, JOHN R. A Visit to the Source of the River Falloch. 'Glasgow Naturalist,' VII. 65-77. 1915.
- LINTON, Rev. E. F. A Tentative Account of the Fungi of East Dorset. Part II. 'Proc. Dorset N. H. A. F. C.' XXXVI. 148-194. 1915.
- LISTER, Miss GULIELMA. Illustrations of Mycetozoa, dedicated to Samuel Dale, M.D., in Micheli's 'Nova Plantarum Genera,' 1729. 'Essex Naturalist,' XVIII. 1-2. 1915.
- Mycetozoa found during the Fungus Foray on October 17, 1914. 'Essex Naturalist,' XVIII. 35-36. 1915.
- Mycetozoa found in the Gower Peninsula. 'Trans. British Mycological Soc.' V. 208-210. 1916.
- MEASHAM, Miss C. E. C. A Botanical Survey of some Fields near Leicester, with an Appendix by A. R. HORWOOD. 'Trans. Leicester Lit. and Phil. Soc.' XIX. 17-28. 1915.



- MERLIN, A. A. C. ELIOT. Notes on Diatom Structure. 'Journal Quekett Mio. Club,' XII. 577-580. 1915.
- MEYRICK, E. Report of the Botanical Section. 'Report Marl. Coll. N. H. Soc.' No. 63, 21-29. 1915.
- PECK, A. E. Mycological Notes from Scarborough. 'The Naturalist for 1915,' 222-224. 1915.
- Yorkshire Mycologists at Scarborough. 'The Naturalist for 1916,' 18-21. 1916.
- PICKARD, JOSEPH FRY. Notes on the Flora of Eskdale and Wasdale. 'The Naturalist for 1915,' 382-384. 1915.
- RAMSBOTTOM, J. Colour Standards. 'Trans. British Mycological Soc.' v. 263-271. 1916.
- Recent published Results on the Cytology of Fungus Reproduction (1915). 'Trans. British Mycological Soc.' v. 271-303. 1916.
- A List of the British Species of Phycomycetes, etc., with a Key to the Genera. 'Trans. British Mycological Soc.' v. 304-317. 1916.
- Note on the List of British Phycomycetes. 'Trans. British Mycological Soc.' v. 318-323. 1916.
- Some Notes on the History of the Classification of the Phycomycetes. 'Trans. British Mycological Soc.' v. 324-350. 1916.
- REA, CARLETON. Report of the Baslow Spring Foray and Complete List of the Fungi. 'Trans. British Mycological Soc.' v. 187-192. 1916.
- Report of the Swansea Foray and Complete List of the Fungi. 'Trans. British Mycological Soc.' v. 196-207. 1916.
- New or Rare British Fungi. 'Trans. British Mycological Soc.' v. 248-257. 1916.
- REA, EMMA AMY. Presidential Address: Notes on Fungus Illustrations. 'Trans. British Mycological Soc.' v. 211-228. 1916.
- RENWICK, JOHN. The Spanish Chestnut (*Castanea sativa* Miller) in the Clyde Area. 'Glasgow Naturalist,' VII. 17-31. 1916.
- and RICHARD M'KAY. Table of Measurements of Spanish Chestnut Trees in Clyde Drainage Area. 'Glasgow Naturalist,' VII. 59-61. 1915.
- RIDGE, W. T. BOYDON. Botanical Report. 'Trans. N. Staffs F. C.' XLIX. 155-157. 1915.
- ROE, T. B. A Celery Fungus. 'The Naturalist for 1916,' 14-15. 1916.
- SALISBURY, DR. E. J. The Sea Shore and its Plant Life. 'Proc. South London Ent. N. H. Soc. 1914-15,' 46-48. 1915.
- Botanical Observations in Hertfordshire during the year 1914, with Notes on *Silene dichotoma* and *Gentiana praecox*. 'Proc. Herts N. H. S. F. C.' XVI. 75-78. 1916.
- SCOTT, FRANK. The Natural Regeneration of Woods. 'Trans. Perthshire Soc. Nat. Sci.' VI. 56-61. 1915.
- SHANKS, ARCH. The Occurrence of *Claytonia sibirica* L. in the Clyde Area. 'Glasgow Naturalist,' VII. 101-103. 1915.
- SUTHERLAND, GEO. K. Additional Notes on Marine Pyrenomycetes. 'Trans. British Mycological Soc.' v. 257-263. 1916.
- TOWN, JOANNA. Desmids found on Hay Tor Moor and Bovey Heathfield. 'Journal Torquay N. H. Soc.' II. 96-98. 1916.
- WATSON, WALTER. The Bog-mosses of Somerset. 'Proc. Somersetshire Arch. N. H. Soc.' LXI. 166-188. 1916.
- WATT, LAWRENCE. Flowering Plants from Banffshire, &c. 'Glasgow Naturalist,' VII. 56-58. 1915.
- and JOHN RENWICK. Notes on the Occurrence of *Goodyera repens* R.Br. in Scotland. 'Glasgow Naturalist,' VII. 47-50. 1915.
- WEISS, Prof. F. E. Aquatic Plants. 'Trans. Manchester Mic. Soc. 1914,' 30-36. 1916.
- YAPP, Prof. R. H. The Sense Organ of Plants. 'Report Belfast N. H. Phil. Soc. 1914-15,' 57-62. 1915.

#### Section L.—EDUCATIONAL SCIENCE.

- HEY, SPURLEY. Incidental Activities of an Education Committee. 'Trans. Manchester Stat. Soc. 1914-15,' 35-46. 1915.

*Section M.—AGRICULTURE.*

STANUELL, CHARLES A. Presidential Address: The Effect of the War on Irish Agriculture. 'Journal Stat. Soc. Ireland,' XIII. 223-230. 1915.

## OBITUARY.

- BALL, Sir CHARLES. By C. G. 'Irish Naturalist,' xxv. 78-79. 1916.  
 BALL, Sir ROBERT. 'Journal Royal Astr. Soc. of Canada,' x. 42-63. 1916.  
 BARRINGTON, RICHARD MANLIFFE. By C. B. Moffat. 'Irish Naturalist,' xxiv. 193-206. 1915.  
 ELLINGTON, EDWARD BAYZAND. 'Trans. Liverpool Eng. Soc.' xxxvi. 288-290. 1915.  
 GILL, Sir DAVID. By Alex. W. Roberts. 'Trans. Royal Soc. of South Africa,' v. 195-224. 1915.  
 JAMES, CHARLES HENRY. By T. H. Thomas. 'Trans. Cardiff Nat. Soc.' XLVII. 7-8. 1915.  
 JUDD, JOHN W. By T. S[heppard]. 'The Naturalist for 1916,' 144. 1916.  
 MERTHYR, Lord. By Dr. W. N. Atkinson. 'Trans. Inst. Min. Eng.' XLVIII. 686-688. 1915.  
 RILEY, WILLIAM. By John W. Rodger. 'Trans. Cardiff Nat. Soc.' XLVII. 9-12. 1915.  
 RUDLER, FREDERICK WILLIAM. By Prof. G. S. Boulger. 'South-Eastern Naturalist for 1915,' XLIV.-XLVI. 1915.  
 TREUTLER, Dr. WILLIAM JOHN. 'South-Eastern Naturalist for 1915,' XLVI.-XLVII. 1915.  
 VACHELL, Dr. CHARLES TANFIELD. By R. D. Patterson. 'Trans. Cardiff Nat. Soc.' XLVII. 1-6. 1915.  
 WARREN, ROBERT. By C. B. Moffat. 'Irish Naturalist,' xxv. 33-44. 1916.  
 WEBSTER, JOHN JAMES. 'Trans. Liverpool Eng. Soc.' xxxvi. 293-294. 1915.

# INDEX.

*References to reports and papers printed in extenso are given in Italics.*  
*An asterisk \* indicates that the title only of the communication is given.*  
*The mark † indicates the same, but that a reference is given to the Journal or Newspaper where the paper is published in extenso.*

**O**FFICERS and Council, 1916-17, iii.  
 Rules of the Association, v.  
 Trustees, General Officers, &c., xxi.  
 Sectional Presidents and Secretaries (1901-15), xxii.  
 Evening Discourses (1901-15), xxx.  
 Lectures to the Operative Classes (1901-11), xxxii.  
 Public Lectures (1912-15), xxxii.  
 Chairmen and Secretaries of Conferences of Delegates (1901-15), xxxiii.  
 Grants of money for scientific purposes (1901-15), xxxiv.  
 Report of the Council, 1915-16, xlv.  
 General Treasurer's Account, xlviii.  
 Attendances and Receipts at Annual Meeting, 1.  
 Analysis of Attendances, lii.  
 Newcastle Meeting, 1916:—  
 General Meetings, xli.  
 Sectional Officers, xli.  
 Officers of Conference of Delegates, xliii.  
 Research Committees, liv.  
 Communication ordered to be printed in extenso, lxvii.  
 Resolutions referred to the Council, lxvii.  
 Synopsis of Grants of Money, lxvii.  
 Caird Fund, lxviii.  
 Public Lectures in Newcastle and vicinity, lxix.

*Address by the President, Sir Arthur Evans, D.Litt., F.R.S., 3.*

\*ABELSON (Dr.), psychological research and race regeneration, 476.

\*Abrolhos Islands, the biology of the, report on, 417.

Absorption spectra and chemical constitution of organic compounds, report on, 131.

1916

Acid rocks of Iceland, the, by Leonard Hawkes, 397.

†Actor, the origin of the, by Prof. W. Ridgeway, 468.

ADAMS (Prof. J.) *on the mental and physical factors involved in education*, 307.

†Aerials, the calculation of the capacity of, including the effects of masts and buildings, by Prof. G. W. O. Howe, 456.

Afforestation after the war, Sir J. S. Stirling-Maxwell on, 505.

Age of geological formations, a method of indicating, on maps in black and white, by Dr. J. W. Evans, 396.

Agricultural Section, Address by Dr. E. J. Russell to the, 528.

AIREY (Dr. J. R.) *on the calculation of mathematical tables*, 59.

ALLEN (J. E.) *on the effects of the war on credit, currency, and finance*, 278.

ALLESTON (Lord) *on fuel economy*, 187.

†Amœbæ from the human mouth, Dr. R. T. Goodey on the, 419.

†Amœbæ in relation to disease, by Dr. Pixell-Goodrich, 418.

\*Anæsthetics, report on, 475.

ANDERSON (Miss A. M.) *on the question of fatigue from the economic standpoint*, 251.

ANDERSON (V. G.) *on the influence of weather conditions on the amounts of nitrogen acids in the rainfall and atmosphere in Australia*, 128.

ANDREWS (Dr. C.) *on the exploration of La Cotte de St. Brelade, Jersey*, 292.

ANDREWS (E. C.) *on the botanical and chemical characters of the eucalypts and their correlation*, 201.

Anthropological Section, Address by Dr. R. R. Marett to the, 458.

Archæological investigations in Malta, report on, 294.

- †Arctic Siberia, a summer and winter among the tribes of, by Miss Czaplicka, 469.
- Arak mountains, the plant geography and flora of the, by Miss L. S. Gibbs, 509.
- \*Arginine and creatine formation, by Prof. W. H. Thompson, 475.
- ARMITAGE (Robert) *on fuel economy*, 187.
- †ARMSTRONG (Dr. E. F.), science in relation to industry, 525.
- ARMSTRONG (Prof. H. E.) *on dynamic isomerism*, 130.
- *on the botanical and chemical characters of the eucalypts and their correlation*, 201.
- *on popular science lectures*, 326.
- ARNOLD (Prof. J. O.) *on fueconomy*, 187.
- \*Aromatic nitroamines, the transformation of, report on, 377.
- Arran pitchstones, the petrology of the, by Dr. A. Scott, 398.
- Artificial islands in the lochs of the highlands of Scotland, report on the distribution of, 303.
- *excavation work on the crannog in Loch Kinellan, Strathpeffer*, by Hugh A. Fraser, 303.
- ASHBY (Dr. T.) *on archæological investigations in Malta*, 294.
- ASHLEY (Miss) *on the replacement of men by women in industry*, 276.
- ASHTON (P. J.), the encouragement of public interest in science by means of popular lectures, 571.
- ASHWORTH (Dr. J. H.) *on the occupation of a table at the zoological station at Naples*, 238.
- ASPINALL (J. A. F.) *on fuel economy*, 187.
- \*Asylum and normal population, the anthropometric characters of the, by Dr. J. F. Tocher, 468.
- \*Atlantic Ocean, periodicity of sea-surface temperature in the, by Dr. E. C. Jee, 434.
- AUDEN (Dr. G. A.) *on the mental and physical factors involved in education*, 307.
- AVERY (D.) *on the influence of weather conditions on the amounts of nitrogen acids in the rainfall and atmosphere of Australia*, 128.
- *on the utilisation of brown coal bye-products*, 205.
- BAKER (R. T.) *on the botanical and chemical characters of the eucalypts and their correlation*, 201.
- BALFOUR (Henry) *on the exploration of La Cotte de St. Brelade, Jersey*, 292.
- *on archæological investigations in Malta*, 294.
- BALL (S.) *on industrial unrest*, 274.
- BALY (Prof. E. C. C.) *on the absorption spectra and chemical constitution of organic compounds*, 131.
- BARKER (A. H.) *on fuel economy*, 187.
- \*BARNARD (J. E.) and Prof. B. MOORE, the nutrition of living organisms by simple organic compounds, 475.
- \*Barnsley thick coal, underground contours of the, by Prof. W. G. Fearnside, 394.
- BARR (Prof. A.) *on stress distributions in engineering materials*, 280.
- BASTABLE (Prof. C. F.) *on the effects of the war on credit, currency, and finance*, 278.
- BATESON (Prof. W.) *on experimental studies in the physiology of heredity*, 306.
- BATHER (Dr. F. A.) *on zoological bibliography and publication*, 239.
- †BAYLISS (Prof. W. M.), the properties required in solutions for intravenous injections, 475.
- BAYLY (P. G. W.) *on the utilisation of brown coal bye-products*, 205.
- †BEATTY (Dr. R. T.), measurement of the energy in spectral lines, 365.
- BEDSON (Prof. P. Phillips) *on fuel economy*, 187.
- \*— *an apparatus for grinding coal in vacuo*, 376.
- †Beef production, economy in, by Prof. T. B. Wood and K. J. J. Mackenzie, 548.
- BELBY (Sir G. T.) *on fuel economy*, 187.
- BELL (Sir Hugh) *on fuel economy*, 187.
- *on industrial unrest*, 274.
- †Bellingham, survey work near, by Miss C. E. C. Measham, 511.
- \*Belmullet whaling station, the biological problems incidental to the, report on, 417.
- BENNETT (Arthur), the federation of cognate societies, 576.
- BEVAN (Rev. J. O.) *on the work of the Corresponding Societies Committee*, 566.
- BIDDER (G. P.) *on the occupation of a table at the zoological station at Naples*, 238.
- BINGLEY (G.) *on the collection of photographs of geological interest*, 218.
- \*Black Mine, underground contours of the, by Dr. G. Hickling, 394.
- BLACKMAN (Prof. F. F.) *on experimental studies in the physiology of heredity*, 306.
- \*Boltzmann's, a problem of, and its relation to the theory of radiation, Dr. H. R. Hassé on, 365.
- BONE (Prof. W. A.) *on fuel economy*, 187.
- *on gaseous explosions*, 292.
- *on popular science lectures*, 326.
- BONNEY (Dr. T. G.) *on the collection of photographs of geological interest*, 218.
- BOOTH (Rt. Hon. Charles) *on industrial unrest*, 274.

- BOSWELL (Dr. P. G. H.), some geological characters of sands used in glass manufacture, 401.
- \*BOSWELL (Dr. P. G. H.) and Prof. W. G. FEARNSIDES on the occurrence of refractory sands in hollows in the surface of the mountain limestone district of Derbyshire and Staffordshire, 400.
- Botanical Section, Address by Dr. A. B. Rendle to the, 477.
- BOTTOMLEY (Prof. W. B.), waste moorlands, 501.
- BOULTON (Prof. W. S.), Address to the Geological Section, 378.
- BOWER (Prof. F. O.) *on the botanical and chemical characters of the eucalypts and their correlation*, 201.
- *on the occupation of a table at the zoological station at Naples*, 238.
- *on the renting of Cinchona botanic station in Jamaica*, 307.
- † — *on leaf architecture*, 493.
- BOWERMAN (Rt. Hon. C. W.) *on industrial unrest*, 274.
- *on the replacement of men by women in industry*, 276.
- BOYS (C. Vernon) *on seismological investigations*, 29.
- BRABROOK (Sir Edward) *on the effects of the war on credit, currency, and finance*, 278.
- *on the mental and physical factors involved in education*, 307.
- *on popular science lectures*, 326.
- *on the work of the Corresponding Societies Committee*, 566.
- Breeding experiments, the means of bringing into closer contact those scientifically and commercially interested in, discussion on, 490.
- Miss E. R. Saunders on, 490.
- BRIERLEY (W. B.), the organisation of phytopathology, 487.
- \*British coal tar colour industry, the British, in peace and war, by C. M. Whittaker, 376.
- †British facial type, the, is it changing? by Prof. A. Keith, 468.
- †British forestry, past and future, by Prof. W. Somerville, 547.
- †British in-shore fisheries, the exploitation of, by Prof. W. A. Herdman, 418.
- †British straws, the composition of, by Prof. T. B. Wood, 548.
- BROWN (Sidney G.) *on radiotelegraphic investigations*, 127.
- BROWN (Dr. W.) *on the mental and physical factors involved in education*, 307.
- Brown coal bye-products, report on the utilisation of*, 205.
- BROWNING (T. B.), the English historical method in economics: rent, 446.
- \*BRUCE (Dr. W. S.), the Weddell Sea, 433.
- BRYCE (Prof. T. H.) *on the distribution of artificial islands in the lochs of the highlands of Scotland*, 303.
- BUCHANAN (Dr. Florence) *on the structure and function of the mammalian heart*, 304.
- BULLER (Prof. R.) *on the renting of Cinchona botanic station in Jamaica*, 307.
- BURBIDGE (Sir Richard) and Dr. G. B. HUNTER, the decimal system in currency, weights, and measures, 446.
- BURSTALL (Prof. F. W.) *on gaseous explosions*, 292.
- BURT (Cyril) *on the mental and physical factors involved in education*, 307.
- BURY (E.) *on fuel economy*, 187.
- CALENDAR (Prof. H. L.) *on gaseous explosions*, 292.
- CAMBAGE (R. H.) *on the botanical and chemical characters of the eucalypts and their correlation*, 201.
- CAMERON (Dr. A. T.) *on the ductless glands*, 305.
- \*Carbon monoxide, the disruptive effect of, at 400° to 500° C., on wrought iron, Dr. J. E. Stead on, 376.
- Carboniferous, permo-carboniferous, and permian rocks of the southern hemisphere, the nomenclature of the, interim report on*, 238.
- CARPENTER (Dr. Charles) *on fuel economy*, 187.
- \*CARR (F. H.), the future of organic chemical industry, 376.
- †Channel Islands, recent archæological discoveries in the, by Dr. R. R. Marett, 469.
- CHAPMAN (D. L.) *on gaseous explosions*, 292.
- CHAPMAN (Prof. S. J.) *on the question of fatigue from the economic standpoint*, 251.
- *on industrial unrest*, 274.
- *on the replacement of men by women in industry*, 276.
- *on popular science lectures*, 326.
- CHAUNDY (T. W.) *on the calculation of mathematical tables*, 59.
- *on the determination of gravity at sea*, 549.
- \*Chemical entomology, by F. M. Howlett, 417.
- Chemical Section, Address by Prof. G. G. Henderson to the, 366.
- \*Chemicals for laboratory use, the preparation of, by W. Rintoul, 376.
- †CHISHOLM (G. G.), generalisations in geography, and more especially in human geography, 433.

- \*Chlorination process, a modified, by Dr. J. A. Smythe, 377.
- CHREE (Dr. C.) on radiotelegraphic investigations, 127.
- on stress distributions in engineering materials, 280.
- Cinchona botanic station in Jamaica, the renting of, report on, 307.*
- CLERK (Dr. Dugald) on fuel economy, 187.
- on gaseous explosions, 292.
- \*Climate and tillage, by T. Wibberley, 548.
- Coal, the bearing of botanical science on, discussion on, 506.
- Coal, the chemical and geological characters of different varieties of, discussion on, 395.
- †Coastal fisheries of Northumberland, the, by Prof. A. Meek, 418.
- COKER (Prof. E. G.) on stress distributions in engineering materials, 280.
- on gaseous explosions, 292.
- COLE (Prof. Grenville A. J.) on the old red sandstone rocks of Kiltorecan, Ireland, 205.
- \*COLLINGWOOD (W. G.), monuments of the early Christian type in Northumbria, 468.
- \*COLLINS (S. H.), the utilisation of forest waste by distillation, 548.
- †Compositæ, geographical distribution of the, by J. Small, 509.
- COOK (Gilbert) on stress distributions in engineering materials, 280.
- Co-operation, by Prof. G. A. Lebour, 566.
- Corresponding Societies Committee:—  
Report, 566.  
Conference at Newcastle, 566.  
List of Corresponding Societies, 589.  
Papers published by Corresponding Societies, 594.
- †CORTIE (Rev. A. L.), efficiency of sunspots in relation to terrestrial magnetic phenomena, 364.
- Credit, currency, and finance, the effects of the war on, abstract of report on, 278.*
- CROMBIE (Dr. J. E.) on seismological investigations, 29.
- CROOK (C. V.) on the collection of photographs of geological interest, 218.
- \*Crystalline form, the correlation of, with molecular structure, report on, 377.
- CULVERWELL (Prof. E. P.) on the mental and physical factors involved in education, 307.
- CUNNINGHAM (Archdeacon W.) on industrial unrest, 274.
- on the replacement of men by women in industry, 276.
- CUNISON (J.) on the replacement of men by women in industry, 276.
- CUSHNY (Prof. A. R.), Address to the Physiological Section, 470.
- †CUSHNY (Prof. A. R.) on the secretion of urea and sugar by the kidney, 475.
- †ZAPLICKA (Miss), a summer and winter among the tribes of Arctic Siberia, 469.
- †— the physical type of the north-western Tungus, 469.
- DALBY (Prof. W. E.) on stress distributions in engineering materials, 280.
- on gaseous explosions, 292.
- DANIELL (G. F.) on the mental and physical factors involved in education, 307.
- DARWIN (H.) on seismological investigations, 29.
- DAVID (Prof. T. W. Edgeworth) on the nomenclature of the carboniferous, permocarboniferous, and permian rocks of the southern hemisphere, 238.
- DAVIS (W. J.) on the replacement of men by women in industry, 276.
- DAVISON (C.) on seismological investigations, 29.
- DAWKINS (Prof. W. Boyd) on the distribution of artificial islands in the lochs of the highlands of Scotland, 303.
- Decimal system in currency, weights, and measures, the, by Sir R. Burbidge and Dr. G. B. Hunter, 446.
- DENDY (Prof. A.) on popular science lectures, 326.
- DESCH (Dr. C. H.) on dynamic isomerism, 130.
- DESPOTT (G.) on the excavations at Ghar Dalam (Malta) in July 1916, 294.
- DICKSEE (Prof. L. R.) on the effects of the war on credit, currency, and finance, 278.
- †Diesel engines, the possibility of working with low compression pressures, by Prof. W. H. Watkinson, 456.
- Discussions:—  
\*On gravitation, 364.  
\*On osmotic pressure, 364.  
On the chemical and geological characters of different varieties of coal, 395.  
†On fuel economy, 457.  
On economic mycology and the necessity for further provision for pathological research, 485.  
On the means of bringing into closer contact those scientifically and commercially interested in breeding experiments, 490.  
The utilisation and improvement of waste lands, 493.  
The bearing of botanical science on coal, 506.  
The collection and cultivation of medicinal plants, 507.  
\*On the place of science in the education of boys, 526.

## Discussions (cont.) :—

- \*On the place of science in the education of girls, 527.
- \*On the mental and physical factors involved in education, 527.
- \*On motor cultivation, 548.
- \*On ensilage, 548.
- \*DIXEY (Dr. F. A.), some points of bionomic interest observed during the British Association visit to Australia, 417.
- DIXON (Prof. H. B.) *on fuel economy*, 187.  
— *on gaseous explosions*, 292.
- DOBBIE (Sir J. J.) *on dynamic isomerism*, 130.  
— *on the absorption spectra and chemical constitution of organic compounds*, 131.
- DOODSON (A. T.) *on the calculation of mathematical tables*, 59.
- Ductless glands, report on the*, 305.
- DUFFIELD (Prof. W. G.) *on the determination of gravity at sea*, 549.
- DUN (W. S.) *on the nomenclature of the carboniferous, permo-carboniferous, and permian rocks of the southern hemisphere*, 238.
- DUNLOP (the late Dr. A.) *on the exploration of La Cotte de St. Brelade, Jersey*, 292.
- DUNN (Dr. J. T.) *on fuel economy*, 187.  
*Dynamic isomerism, report on*, 130.
- DYSON (Sir F. W.) *on seismological investigations*, 29.  
— *on radiotelegraphic investigations*, 127.
- † — *the mean distances of stars of different magnitudes*, 364.
- \*Easter Island, megalithic remains on, by Scoresby Routledge, 468.
- \* — recent culture on, and its relation to past history, by Mrs. Scoresby Routledge, 469.
- ECCLES (Dr. W. H.) *on radiotelegraphic investigations*, 127.
- \*Economic maps, by G. Philip, 434.
- Economic mycology and the necessity for further provision for pathological research, discussion on, 485.  
— Prof. M. C. Potter on, 485.
- Economic Science and Statistics, Address to the Section of, by Prof. A. W. Kirkaldy, 435.
- EDDINGTON (Prof. A. S.) *on radiotelegraphic investigations*, 127.  
— *on the determination of gravity at sea*, 549.
- † EDGELL (Miss), experiments upon the effectiveness of war-economy posters, 476.
- EDGEWORTH (Prof. F. Y.) *on the effects of the war on credit, currency, and finance*, 278.
- Educational Section, Address by Rev. W. Temple to the, 512.
- † Egyptian Bilharzia worms, bionomics of the, by Dr. R. T. Leiper, 417.
- Electromotive phenomena in plants, report on*, 305.
- \* *Electromotive phenomena of the heart, report on*, 474.
- ELLINGER (Barnard) *on the effects of the war on credit, currency, and finance*, 278.
- ELLISON (Dr. F. O'B.) *on electromotive phenomena in plants*, 305.
- \* Emotional disturbances from a biological point of view, by Dr. Murray, 476.
- \* Endemics, are they the oldest or the youngest species in a country? by Dr. J. C. Willis, 509.
- Engineering Section, Address by Gerald G. Stoney to the, 448.
- \* English Channel, the waters of the, annual variations in the temperature and salinity of, by Dr. E. C. Jee, 434.
- English historical method in economics, the; rent, by T. B. Browning, 446.
- \* Ensilage, discussion on, 548.
- ERSKINE-MURRAY (Dr.) *on radiotelegraphic investigations*, 127.
- Eucalypts, the, the botanical and chemical characters of, and their correlation, second report on*, 201.
- \* Eugenics and war, by Hugh Richardson, 420.
- EVANS (Sir Arthur), *Presidential Address*, 3.  
— *on popular science lectures*, 326.
- \* EVANS (I. H. N.), some beliefs and customs of the aborigines of the Malay States, 468.
- EVANS (Dr. J. W.) *on the old red sandstone rocks of Kiltorcan, Ireland*, 205.  
— a method of indicating the age of geological formations on maps in black and white, 396.
- EWART (Prof. A. J.) *on the botanical and chemical characters of the eucalypts and their correlation*, 201.
- EWING (Sir J. A.) *on stress distributions in engineering materials*, 280.
- EYRE (Dr. J. Vargas) and E. S. SALMON on the treatment of fungous diseases by spraying, 488.
- \* *Eyesight, the influence of school-books upon, report on*, 527.
- FANTHAM (Dr. H. B.) and Dr. ANNIE PORTER, the flagellate protozoa associated with diarrhoea and dysentery, 419.
- FARMER (Prof. J. B.) *on electromotive phenomena in plants*, 305.

- Fatigue from the economic standpoint, the question of, second interim report on*, 251.
- FAWSITT (Prof. C. E.) *on the botanical and chemical characters of the eucalypts and their correlation*, 201.
- \*FEARNSIDES (Prof. W. G.), *underground contours of the Barnsley thick coal*, 394.
- \*— and Dr. P. G. H. BOSWELL *on the occurrence of refractory sands in hollows in the surface of the mountain limestone district of Derbyshire and Staffordshire*, 400.
- Federation of cognate societies, the*, by Arthur Bennett, 576.
- FERRANTI (S. Z. de) *on fuel economy*, 187.
- FILON (Prof. L. N. G.) *on the calculation of mathematical tables*, 59.
- *on stress distributions in engineering materials*, 280.
- \*Fishes, the age of, the determination of, by their scales, Dr. A. T. Masterman on, 418.
- Flagellate protozoa, the, associated with diarrhoea and dysentery, by Drs. H. B. Fantham and Annie Potter, 419.
- FLEMING (Prof. J. A.) *on radiotelegraphic investigations*, 127.
- FLETT (Dr. G. S.) *on the excavation of critical sections in the plant-bearing cherts at Rhynie, Aberdeenshire*, 206.
- *on the lower carboniferous flora at Gullane*, 217.
- \*FLEURE (Prof. H. J.), France: a regional interpretation, 433.
- †Flies, likes and dislikes of, by Miss O. C. Lodge, 418.
- FLORENCE (P. Sargant) *on the question of fatigue from the economic standpoint*, 251.
- \*Food standards and man power, by Dr. A. D. Waller, 475.
- FORDHAM (Sir George) *on the work of the Corresponding Societies Committee*, 566.
- FORSTER (Dr. M. O.) *on the study of hydroaromatic substances*, 79.
- *on dynamic isomerism*, 130.
- \*Forest waste, the utilisation of, by distillation, by S. H. Collins, 548.
- FOXLEY (Prof. B.) *on the mental and physical factors involved in education*, 307.
- \*France: a regional interpretation, by Prof. H. J. Fleure, 433.
- FRASER (Hugh A.), *excavation work on the crannog in Loch Kinellan, Strathpeffer*, 303.
- \*Free-place system in education, report on the, 527.
- Fuel economy, first report on*, 187.
- †— discussion on, 457.
- FULTON (A. R.) *on stress distributions in engineering materials*, 280.
- Fungous diseases, the treatment of, by spraying, E. S. Salmon and Dr. J. V. Eyre on, 488.
- GALLOWAY (Dr. William) *on fuel economy*, 187.
- GARSON (Dr. J. G.) *on the work of the Corresponding Societies Committee*, 566.
- GARWOOD (Prof. E. J.) *on the lower carboniferous flora at Gullane*, 217.
- *on the collection of photographs of geological interest*, 218.
- Gaseous explosions, interim report on*, 292.
- GEE (Prof. W. W. Haldane) *on fuel economy*, 187.
- †Generalisations in geography, and more especially in human geography, by G. G. Chisholm, 433.
- †GENESE (Prof. R. W.), suggestions for the practical treatment of the standard cubic equation and a contribution to substitution theory, 365.
- Geographical Section, Address by Edward A. Reeves to the, 421.
- Geological photographs, eighteenth report on the collection of*, 218.
- Geological Section, Address by Prof. W. S. Boulton to the, 378.
- Ghar Dalam (Malta), excavations at, in July 1916*, by G. Despott, 294.
- GIBBS (Miss S. L.) *on the plant geography and flora of the Arfak mountains*, 509.
- GIBSON (A. H.) *on the effects of the war on credit, currency, and finance*, 278.
- \*GILCHRIST (Prof. D. A.), the relation of manuring and cropping to economy in meat production, 548.
- GLAZEBROOK (Dr. R. T.) *on seismological investigations*, 29.
- *on gaseous explosions*, 292.
- †— limit gauges, 456.
- GONNER (Prof. E. C. K.) *on industrial unrest*, 274.
- *on the replacement of men by women in industry*, 276.
- *on the effects of the war on credit, currency, and finance*, 278.
- †GOODEY (Dr. R. T.) *on the amœbæ from the human mouth*, 419.
- \*— soil protozoa and soil bacteria, 547.
- GOODRICH (E. S.) *on the occupation of a table at the zoological station at Naples*, 238.
- GORDON (Dr. W. T.) *on the excavation of critical sections in the plant-bearing cherts at Rhynie, Aberdeenshire*, 206.
- *on the lower carboniferous flora at Gullane*, 217.
- GOSLING (H.) *on industrial unrest*, 274.
- \*Gravitation, discussion on, 364.



- Gravity at sea, the determination of, report on, 549.*
- GRAY (Rev. Dr. H. B.) on combining literary and scientific subjects in the course of general education, 524.
- GRAY (Prof. Thos.) on fuel economy, 187.
- GRAY (W.) on the collection of photographs of geological interest, 218.
- GREEN (Dr. Heber) on the botanical and chemical characters of the eucalypts and their correlation, 201.
- GREEN (Prof. J. A.) on the mental and physical factors involved in education, 307.
- GREENER (T. Y.) on fuel economy, 187.
- GREENHILL (Sir George) on the calculation of mathematical tables, 59.
- GREGORY (Prof. R. A.) on the mental and physical factors involved in education, 307.
- on popular science lectures, 326.
- GREGORY (R. P.) on experimental studies in the physiology of heredity, 306.
- GRIFFITHS (Principal E. H.) on the work of the Corresponding Societies Committee, 566.
- \*Grinding coal in vacuo, an apparatus for, by Dr. P. Phillips Bedson, 376.
- GRUCHY (G. de) on the exploration of La Cotte de St. Brelade, Jersey, 292.
- GUEST (J. J.) on stress distributions in engineering materials, 280.
- Gullane, the lower carboniferous flora at, report on, 217.*
- HADDON (Dr. A. C.) on archaeological investigations in Malta, 294.
- \*— the main cultures of New Guinea, 468.
- on the work of the Corresponding Societies Committee, 566.
- HADFIELD (Sir Robert) on fuel economy, 187.
- \*HADOW (Principal W. H.), science in the universities, 525.
- HALL (Dr. Cuthbert) on the botanical and chemical characters of the eucalypts and their correlation, 201.
- HALLIBURTON (Prof. W. D.) on popular science lectures, 326.
- †— the effect of pituitary extract on the secretion of cerebro-spinal fluid, 475.
- Handicraft, the place of, in schools, by J. G. Legge, 523.
- HARDY (Dr. W. B.) on the occupation of a table at the zoological station at Naples, 238.
- HARKER (Dr. J. A.) on gaseous explosions, 292.
- HARMER (Dr. S. F.) on the occupation of a table at the zoological station at Naples, 238.
- \*HASSÉ (Dr. H. R.) on a problem of Boltzmann's and its relation to the theory of radiation, 365.
- \*HAVELOCK (Prof. T. H.), propagation of a signal in a dispersive medium, 364.
- \*HAVERFIELD (Prof.), the Roman wall, 468.
- HAWKES (Leonard), the acid rocks of Iceland, 397.
- HEATH (St. G.) on the replacement of men by women in industry, 276.
- HEATON (Howard) on industrial unrest, 274.
- HELE-SHAW (Dr. H. S.) on fuel economy, 187.
- on popular science lectures, 326.
- HELPS (Dr. H.) on fuel economy, 187.
- HENDERSON (Prof. G. G.), Address to the Chemical Section, 366.
- HENDERSON (Prof. J. B.) on stress distributions in engineering materials, 280.
- HERDMAN (Prof. W. A.) on popular science lectures, 326.
- †— the exploitation of British in-shore fisheries, 418.
- on the work of the Corresponding Societies Committee, 566.
- Heredity, the physiology of, experimental studies in, report on, 306.*
- \*HERON-ALLEN (E.) the mussel-fishery and the life of Alcide d'Orbigny at Esnandes (La Rochelle), 417.
- \*HERRING (Prof. P. T.), the action of thyroid on the suprarenals and heart, 475.
- \*Herring, mackerel, and pilchard fisheries off the south-west coasts, the fluctuations of the, by Dr. E. C. Jee, 418.
- HICKLING (Dr. G.) on the excavation of critical sections in the plant-bearing cherts at Rhynie, Aberdeenshire, 206.
- \*— underground contours of the Black Mine, 394.
- †HICKS (Prof. W. M.), Can the frequencies of spectral lines be represented as a function of their order? 364.
- HICKSON (Prof. S. J.) on the occupation of a table at the zoological station at Naples, 238.
- HILL (Prof. M. J. M.) on the calculation of mathematical tables, 59.
- HIRST (F. W.) on the effects of the war on credit, currency, and finance, 278.
- HOBSON (Prof. E. W.) on the calculation of mathematical tables, 59.
- HOLDEN (Col. H. C. L.) on gaseous explosions, 292.
- HOLDEN (Pickup) on industrial unrest, 274.
- HOLDICH (Col. Sir T. H.) on political boundaries, 241.
- HOLLAND (Prof. Sir T. H.) on the nomenclature of the carboniferous, permian, and permian rocks of the southern hemisphere, 238.

- HOLMES (T. V.) *on the work of the Corresponding Societies Committee*, 566.
- HOPKINSON (Prof. B.) *on gaseous explosions*, 292.
- HOPKINSON (J.) *on the work of the Corresponding Societies Committee*, 566.
- HORNE (Dr. J.) *on the excavation of critical sections in the plant-bearing chert at Rhynie, Aberdeenshire*, 206.
- *on the lower carboniferous flora at Gullane*, 217.
- HOWCHIN (W.) *on the nomenclature of the carboniferous, permo-carboniferous, and permian rocks of the southern hemisphere*, 238.
- HOWE (Prof. G. W. O.) *on radiotelegraphic investigations*, 127.
- † — *the calculation of the capacity of aeriels, including the effects of masts and buildings*, 456.
- \*HOWLETT (F. M.), *chemical entomology*, 417.
- \* — *military entomology*, 418.
- HOYLE (Dr. W. E.) *on zoological bibliography and publication*, 239.
- \*HRDLICKA (Dr. A.), *transpacific migrations*, 469.
- \*Hull, the port of, the evolution of, by Capt. Rodwell Jones, 434.
- HUNT (H. A.) *on the influence of weather conditions on the amounts of nitrogen acids in the rainfall and atmosphere in Australia*, 128.
- HUNTER (Dr. G. B.) and Sir RICHARD BURBIDGE, *the decimal system in currency, weights, and measures*, 446.
- HUTCHINS (Miss B. L.) *on the question of fatigue from the economic standpoint*, 251.
- \**Hydroaromatic substances, the study of, report on*, 377.
- Importance, the, of combining literary and scientific subjects in the course of general education, by Rev. H. B. Gray, 524.
- Industrial unrest, abstract of report on*, 274.
- \**Infancy and childhood, some aspects of in the light of Freudian principles*, by Miss Turner, 476.
- \**Instinct, the concept of*, Prof. Nunn on, 476.
- †*Intravenous injections, the properties required in solutions for*, by Prof. W. M. Bayliss, 475.
- †*Ionisation potential*, by Prof. J. C. McLennan, 364.
- \*ITAGAKI (Dr.), *the action of ovarian extracts*, 475.
- \**Italy and the Adriatic*, by Miss M. Newbiggin, 434.
- JACKSON (E. J. W.) *on industrial unrest*, 274.
- \**Japanese Alps, recent exploration in the*, by Rev. W. Weston, 434.
- \*JEE (Dr. E. C.), *the fluctuations of the herring, mackerel, and pilchard fisheries off the south-west coasts*, 418.
- \* — *annual variations in temperature and salinity of the waters of the English Channel*, 434.
- \* — *periodicity of sea-surface temperature in the Atlantic Ocean*, 434.
- †JEVONS (Dr. F. B.), *magic and religion*, 468.
- JOHNSON (Prof. T.) *on the old red sandstone rocks of Kiltorcan, Ireland*, 205.
- *on electromotive phenomena in plants*, 305.
- †JOHNSTONE (Dr. James), *the further development of the shell-fisheries*, 418.
- JONES (Greville) *on fuel economy*, 187.
- \*JONES (Capt. Rodwell), *the evolution of the port of Hull*, 434.
- JULIAN (Mrs. H. F.) *on the importance of Kent's Cavern as a national site*, 582.
- KEEBLE (Prof. F.) *on experimental studies in the physiology of heredity*, 306.
- *on popular science lectures*, 326.
- KEITH (Prof. A.) *on the exploration of La Cotte de St. Brelade, Jersey*, 292.
- † — *Is the British facial type changing?* 468.
- KENNEDY (G.) *on the calculation of mathematical tables*, 59.
- KENT (Prof. Stanley) *on the question of fatigue from the economic standpoint*, 251.
- *on the structure and function of the mammalian heart*, 304.
- Kent's Cavern, the importance of, as a national site*, by Mrs. H. F. Julian, 582.
- KIDSTON (Dr. R.) *on the old red sandstone of Kiltorcan, Ireland*, 205.
- *on the excavation of critical sections in the plant-bearing cherts at Rhynie, Aberdeenshire*, 206.
- — *report on the plants*, 216.
- *on the lower carboniferous flora at Gullane*, 217.
- *on the collection of photographs of geological interest*, 218.
- and Prof. W. H. LANG *on Rhynia Gwynne-Vaughani*, 493.
- KIMMINS (Dr. C. W.) *on the mental and physical factors involved in education*, 307.
- † — *on London children's ideas as to how they can help in time of war*, 476.
- KING (W. W.) *on the thick coal of South Staffordshire*, 393.

- KIRKALDY (Prof. A. W.) *on industrial unrest*, 274.  
 — *on the effects of the war on credit, currency, and finance*, 278.  
 — Address to the Section of Economic Science and Statistics, 435.
- KITSON (A. E.) *on the nomenclature of the carboniferous, permo-carboniferous, and permian rocks of the southern hemisphere*, 238.
- KNOTT (Prof. C. G.) *on seismological investigations*, 29.
- †KOJIMA (Dr.), the effect of thyroid-feeding on the pancreas, 475.
- LACKIE (W. W.) *on fuel economy*, 187.  
*La Cotte de St. Brelade, Jersey, report on the exploration of*, 292.
- LAMB (Prof. H.) *on seismological investigations*, 29.
- LAMPLUGH (G. W.) *on the nomenclature of the carboniferous, permo-carboniferous, and permian rocks of the southern hemisphere*, 238.  
 — *on popular science lectures*, 326.
- LANG (Prof. W. H.) and Dr. R. KIDSTON *on Rhynia Gwynne-Vaughani*, 493.
- LANKESTER (Sir E. Ray) *on the occupation of a table at the zoological station at Naples*, 238.
- LARMOR (Prof. Sir J.) *on seismological investigations*, 29.
- LEA (Prof. F. C.) *on stress distributions in engineering materials*, 280.
- †Leaf architecture, Prof. F. O. Bower on, 493.
- \*LEBOUR (Prof. G. A.), local geology, 393.  
 — *co-operation*, 566.
- LEGGE (J. G.), the place of handicraft in schools, 523.
- †LEIPER (Dr. R. T.), bionomics of the Egyptian Bilharzia worms, 417.
- †LE MAISTRE (C.), standardisation and its influence on the engineering industries, 456.
- LEWIS (A. L.) *on the work of the Corresponding Societies Committee*, 566.
- †Limit gauges, by Dr. R. T. Glazebrook, 456.
- \*Local geology, by Prof. G. A. Lebour, 393.
- LODGE (Prof. Alfred) *on the calculation of mathematical tables*, 59.
- †LODGE (Miss O. C.), likes and dislikes of flies, 418.
- LODGE (Sir Oliver) *on radiotelegraphic investigations*, 127.
- †London children's ideas as to how they can help in time of war, Dr. C. W. Kimmins on, 476.
- LONGRIDGE (Michael) *on fuel economy*, 187.
- LOVE (Prof. A. E. H.) *on seismological investigations*, 29.  
 — *on the calculation of mathematical tables*, 59.  
 — *on stress distributions in engineering materials*, 280.  
 — *on the determination of gravity at sea*, 549.
- LOW (Dr. A.) *on the distribution of artificial islands in the lochs of the highlands of Scotland*, 303.
- Lower carboniferous flora at Gullane, report on the*, 217.
- LOWRY (Dr. T. M.) *on dynamic isomerism*, 130.
- MACALLUM (Prof. A. B.) *on the ductless glands*, 305.
- MACARA (Sir C. W.) *on industrial unrest*, 274.
- MACBRIDE (Prof. E. W.), Address to the Zoological Section, 403.
- MACDONALD (Dr. H. M.) *on seismological investigations*, 29.  
 — *on the calculation of mathematical tables*, 59.  
 — *on radiotelegraphic investigations*, 127.
- MCDUGALL (W.) *on the mental and physical factors involved in education*, 307.
- MCINTOSH (Prof. W. C.) *on the occupation of a table at the zoological station at Naples*, 238.
- \*MACKENZIE (K. J. J.) and Dr. F. H. A. MARSHALL, the inheritance of mutton points, 548.
- †— and Prof. T. B. WOOD, economy in beef production, 548.
- MACKIE (Dr. W.) *on the excavation of critical sections in the plant-bearing cherts at Rhynie, Aberdeenshire*, 206.
- †MCLACHLAN (N. W.), some characteristic curves for a Poulsen arc generator, 456.
- \*MCLENNAN (Prof. J. C.), ionisation potential, 364.
- MCLUCKIE (J.) *on the botanical and chemical characters of the eucalypts and their correlation*, 201.
- †Magic and religion, by Dr. F. B. Jevons, 468.
- MATTLAND (Dr. T. G.) *on the question of fatigue from the economic standpoint*, 251.
- \*Malay States, the aborigines of the, some beliefs and customs of, by I. H. N. Evans, 468.
- Malta, archæological investigations in, report on*, 294.

- Malta, excavations at Ghar Dalam in July 1916*, 294.
- Mammalian heart, the structure and function of the, report on*, 304.
- \*Manure heaps, losses from, by Dr. E. J. Russell and E. H. Richards, 548.
- MARETT (Dr. R. R.) *on the exploration of La Cotte de St. Brelade, Jersey*, 292.
- *on archaeological investigations in Malta*, 294.
- Address to the Anthropological Section, 458.
- †— recent archæological discoveries in the Channel Islands, 469.
- Maritime waste lands, by Prof. F. W. Oliver, 495.
- \*MARRECO (Miss B. Freire), personal experience as an element in folk tales, 469.
- MARSDEN (Mary E.), the science training which should be given to girls, 526.
- \*MARSHALL (Dr. F. H. A.) and K. J. J. MACKENZIE, the inheritance of mutton points, 548.
- \**Marsupials, report on the collection of*, 417.
- MARTINEAU (P. E.), the planting of pit mounds, 494.
- MASON (D. M.) *on the effects of the war on credit, currency, and finance*, 278.
- MASON (W.) *on stress distributions in engineering materials*, 280.
- MASSON (Prof. Orme) *on the influence of weather conditions on the amounts of nitrogen acids in the rainfall and atmosphere in Australia*, 128.
- *on the botanical and chemical characters of the eucalypts and their correlation*, 201.
- *on the utilisation of brown coal by-products*, 205.
- †MASTERMAN (Dr. A. T.), the scheme of mussel-purification of the Conway fishery, 418.
- \*— on the determination of the age of fishes by their scales, 418.
- Mathematical and Physical Section, Address by Prof. A. N. Whitehead to the, 355.
- Mathematical tables, the calculation of, report on*, 59.
- MATHESON (Miss M. C.) *on the question of fatigue from the economic standpoint*, 251.
- MATHEWS (Prof. G. B.) *on the calculation of mathematical tables*, 59.
- †MEASHAM (Miss C. E. C.), survey work near Bellingham, 511.
- †Measurement of time, the, by Prof. H. H. Turner, 364.
- \*Meat production, economy in, the relation of manuring and cropping to, by Prof. D. A. Gilchrist, 548.
- Medicinal plants, the collection and cultivation of, discussion on, 507.
- †MEEK (Prof. A.), the coastal fisheries of Northumberland, 418.
- \*— the scales of fishes and their value as an aid to investigation, 418.
- \*Megalithic remains on Easter Island, by Scoresby Routledge, 468.
- MELLOR (Dr. J. W.) *on fuel economy*, 187.
- Mental and physical factors involved in education, report on the*, 307.
- \*— discussion on, 527.
- MEREDITH (Mrs.) *on the question of fatigue from the economic standpoint*, 251.
- MERZ (C. H.) *on fuel economy*, 187.
- †Methane, the electrical ignition of, the influence of pressure on, by Prof. W. M. Thornton, 456.
- \*Military entomology, by F. M. Howlett, 418.
- MITCHELL (Dr. P. Chalmers) *on zoological bibliography and publication*, 239.
- MOND (Robert) *on fuel economy*, 187.
- \*Monuments of the early Christian type in Northumbria, by W. G. Collingwood, 468.
- \*MOORE (Prof. B.) and J. E. BARNARD, the nutrition of living organisms by simple organic compounds, 475.
- MOORE (Bernard) *on fuel economy*, 187.
- \*Motor cultivation, discussion on, 548.
- Movements executed by young fern fronds, the, Miss T. L. Pranker on, with especial reference to geotropism, 511.
- MUIRHEAD (Prof. J. H.) *on the question of fatigue from the economic standpoint*, 251.
- \*MURRAY (Dr.), emotional disturbances from a biological point of view, 476.
- †MURRAY (Miss M.), organisations of witches in Great Britain, 469.
- \**Museums, the character, work, and maintenance of, report on*, 527.
- \*Mussel-fishery, the, and the life of Alcide d'Orbigny at Esnandes (La Rochelle), by E. Heron-Allen, 417.
- †Mussel-purification of the Conway fishery, the scheme of, by Dr. A. T. Masterman, 418.
- \*Mutton points, the inheritance of, by K. J. J. Mackenzie and Dr. F. H. A. Marshall, 548.
- MYERS (Dr. C. S.) *on the question of fatigue from the economic standpoint*, 251.
- *on the mental and physical factors involved in education*, 307.
- MYRES (Prof. J. L.) *on archæological investigations in Malta*, 294.
- *on the distribution of artificial islands in the lochs of the highlands of Scotland*, 303.

- \*New Guinea, the main cultures of, by Dr. A. C. Haddon, 468.
- †NEWBIGIN (H. T.), pressure oil film lubrication, 456.
- \*NEWBIGIN (Miss M.), Italy and the Adriatic, 434.
- NICHOLSON (Prof. J. S.) *on the effects of the war on credit, currency, and finance*, 278.
- NICHOLSON (Prof. J. W.) *on the calculation of mathematical tables*, 59.
- *on radiotelegraphic investigations*, 127.
- \*Nickel and copper oxides, solid, the reduction of, by solid iron, Dr. J. E. Stead on, 376.
- \*Nickel steel, the oxidation of, Dr. J. E. Stead on, 376.
- \*Nitrogen in fæces, the fixation of, by E. H. Richards, 548.
- Nitrogen acids in the rainfall and atmosphere in Australia, the influence of weather conditions on the amounts of, interim report on*, 128.
- \**Nomenclator animalium generum et subgenerum, report on the*, 417.
- \**Non-aromatic diazonium salts, report on*, 377.
- NORMAN (Sir H.) *on radiotelegraphic investigations*, 127.
- Northern mountain and heath land, utilisation of, by Dr. W. G. Smith, 498.
- Northern Pennines, the, the physical geography and geology of, by Dr. A. Wilmore, 398.
- NUNN (Prof. T. P.) *on the mental and physical factors involved in education*, 307.
- \*— *on the concept of instinct*, 476.
- \*Nutrition of living organisms, the, by simple organic compounds, by Prof. B. Moore and J. E. Barnard, 475.
- OGDEN (C. K.) *on the question of fatigue from the economic standpoint*, 251.
- Old red sandstone rocks of Kiltoran, Ireland, interim report on*, 205.
- OLIVER (Prof. F. W.) *on the renting of Cinchona botanic station in Jamaica*, 307.
- *on the utilisation and improvement of waste lands*, 493.
- *maritime waste lands*, 495.
- \*Organic chemical industry, the future of, by F. H. Carr, 376.
- Oscillating and asymptotic series, by Prof. G. N. Watson, 365.
- O'SHEA (Prof. L. T.) *on fuel economy*, 187.
- \*Osmotic pressure, discussion on, 364.
- \*Outlets for labour on the land, by Christopher Turnor, 446.
- \*Ovarian extracts, the action of, by Dr. Itagaki, 475.
- \*Oxidation of nickel steel, the, Dr. J. E. Stead on, 376.
- PALGRAVE (Sir R. H. Inglis) *on the effects of the war on credit, currency, and finance*, 278.
- †Pancreas, the effect of thyroid-feeding on the, by Dr. Kojima, 475.
- PARSONS (Sir Charles) *on fuel economy*, 187.
- PEACH (Dr. B. N.) *on the excavation of critical sections in the plant-bearing cherts at Rhynie, Aberdeenshire*, 206.
- *on the lower carboniferous flora at Gullane*, 217.
- Peat-lands in Carnarvonshire, reclamation of, by Prof. J. Lloyd Williams and G. W. Robinson, 502.
- †Permian of Durham, the, Dr. D. Woolcott on, 393.
- PERRY (Prof. John) *on seismological investigations*, 29.
- *on stress distributions in engineering materials*, 280.
- *on popular science lectures*, 326.
- *on the work of the Corresponding Societies Committee*, 566.
- \*Personal experience as an element in folk tales, by Miss B. Freire Marreco, 469.
- PETAVEL (Prof. J. E.) *on stress distributions in engineering materials*, 280.
- *on gaseous explosions*, 292.
- \*PHILIP (G.), economic maps, 434.
- Photographs of geological interest, the collection of, eighteenth report on*, 218.
- Physical and Mathematical Section, Address by Prof. A. N. Whitehead to the, 355.
- Physiological Section, Address by Prof. A. R. Cushny to the, 470.
- Phytopathology, the organisation of, by W. B. Brierley, 487.
- Pit mounds, the planting of, by P. E. Martineau, 494.
- †Pituitary extract, the effect of, on the secretion of cerebro-spinal fluid, by Prof. W. D. Halliburton, 475.
- †PIXELL-GOODRICH (Dr.), amœbæ in relation to disease, 418.
- Plant-bearing cherts at Rhynie, Aberdeenshire, report on the excavation of critical sections therein*, 206.
- *report on the plants*, by Dr. Kidston, 216.
- \**Plant enzymes, the study of, report on*, 377.
- \**Plant products of Victoria, the natural, report on*, 377.
- Plant pathology, training in, by J. Ramsbottom, 487.

- PLUMMER (Prof. H. C.) *on seismological investigations*, 29.
- PLUMMER (W. E.) *on seismological investigations*, 29.
- \**Plymouth marine laboratory, report on the occupation of a table at the*, 417.
- \*Points of bionomic interest observed during the British Association visit to Australia, by Dr. F. A. Dixey, 417.
- Political boundaries*, by Col. Sir T. H. Holdich, 241.
- Popular science lectures, interim report on*, 326.
- PORTER (Dr. Annie) and Dr. H. B. FANTHAM, the flagellate protozoa associated with diarrhoea and dysentery, 419.
- POTTER (Prof. M. C.) on economic mycology and the necessity for further provision for pathological research, 485.
- †Poulsen arc generator, some characteristic curves for a, by N. W. McLachlan, 456.
- POULTON (Prof. E. B.) *on zoological bibliography and publication*, 239.
- PRANKERD (Miss T. L.) on the movements executed by young fern fronds, with especial reference to geotropism, 544.
- on the distribution of starch in the branches of trees, and its bearing on the statolith theory, 544.
- †Pressure oil film lubrication, by H. T. Newbigin, 456.
- \*Propagation of a signal in a dispersive medium, by Prof. T. H. Havelock, 364.
- \**Psychological problems arising out of the war, research into, report on the organisation of*, 476.
- \*Psychological research and race regeneration, by Dr. Abelson, 476.
- †Psychology and sociology, by Dr. W. H. R. Rivers, 476.
- Public interest in science, the encouragement of, by means of popular lectures*, by P. J. Ashton, 571.
- \*Race regeneration, psychological research and, by Dr. Abelson, 476.
- Radiotelegraphic investigations, report on*, 127.
- RAMSBOTTOM (J. W.) *on the question of fatigue from the economic standpoint*, 251.
- RAMSBOTTOM (J.), training in plant pathology, 487.
- REDMAYNE (Sir Richard) *on fuel economy*, 187.
- REEVES (Edward A.), Address to the Geographical Section, 421.
- \*Refractory sands in hollows in the surface of the mountain limestone district of Derbyshire and Staffordshire, the occurrence of, Prof. W. G. Fearnside and Dr. P. G. H. Boswell on, 400.
- REID (A. S.) *on the collection of the photographs of geological interest*, 218.
- †Religion and magic, by Dr. F. B. Jevons, 468.
- RENDELE (Dr. A. B.), Address to the Botanical Section, 477.
- RENNIE (Prof. E. H.) *on the botanical and chemical characters of the eucalypts and their correlation*, 201.
- Replacement of men by women in industry, the, abstract of report on*, 276.
- REYNOLDS (Prof. S. H.) *on the collection of photographs of geological interest*, 218.
- Rhynia Gwynne-Vaughani*, Dr. R. Kidston and Prof. W. H. Lang on, 493.
- Rhynie, Aberdeenshire, the plant-bearing cherts at, report on the excavation of critical sections in*, 206.
- \*RICHARDS (E. H.) the fixation of nitrogen in faeces, 548.
- \*— and Dr. E. J. RUSSELL, losses from manure heaps, 548.
- \*RICHARDSON (Hugh), war and eugenics, 420.
- RIDGEWAY (Prof. W.) *on the distribution of artificial islands in the lochs of the highlands of Scotland*, 303.
- †— the origin of the actor, 468.
- \*RINTOUL (W.) the preparation of chemicals for laboratory use, 376.
- RIPPER (Prof.) *on fuel economy*, 187.
- RIVERS (Dr. W. H. R.) *on the mental and physical factors involved in education*, 307.
- †— the cultivation of taro, 468.
- †— sociology and psychology, 476.
- ROBB (Dr. J. Jenkins) *on the question of fatigue from the economic standpoint*, 251.
- ROBINSON (G. W.) and Prof. J. LLOYD WILLIAMS, reclamation of peat-lands in Carnarvonshire, 502.
- ROBINSON (Prof. R.) *on the botanical and chemical characters of the eucalypts and their correlation*, 201.
- ROGERS (Dr. A. W.) *on the nomenclature of the carboniferous, permo-carboniferous, and permian rocks of the southern hemisphere*, 238.
- ROGERS (Dr. F.) *on stress distributions in engineering materials*, 280.
- \*Roman wall, the, by Prof. Haverfield, 468.
- \*ROTH (H. Ling), the evolution of the weaving spool and shuttle, 468.
- \*ROUTLEDGE (Scoresby), megalithic remains on Easter Island, 468.
- \*ROUTLEDGE (Mrs. Scoresby), recent culture on Easter Island, and its relation to past history, 469.
- RUSSELL (Dr. E. J.) *on popular science lectures*, 326.

- RUSSELL (Dr. E. J.), Address to the Agricultural Section, 528.
- \*— and E. H. RICHARDS, losses from manure heaps, 548.
- †RUTHERFORD (Sir E.) X-ray spectra of the elements, 364.
- ST. JOHN (P. R. H.) *on the botanical and chemical characters of the eucalypts and their correlation*, 201.
- SALMON (E. S.) and Dr. J. VARGAS EYBE, on the treatment of fungous diseases by spraying, 488.
- \*Salonika: its geographical relation to the interior, by H. C. Woods, 434.
- †Salt-marsh 'pans,' the origin and fate of, by Prof. R. H. Yapp, 509.
- SAMPSON (Prof. R. A.) *on seismological investigations*, 29.
- Sands used in glass manufacture, some geological characters of, by Dr. P. G. H. Boswell, 401.
- SANKEY (Capt. H. R.) *on radiotelegraphic investigations*, 127.
- *on gaseous explosions*, 292.
- SAUNDERS (Miss E. R.) *on experimental studies in the physiology of heredity*, 306.
- on the means of bringing into closer contact those scientifically and commercially interested in breeding experiments, 490.
- SAVIDGE (H. G.) *on the calculation of mathematical tables*, 59.
- \*Scales of fishes, the, and their value as an aid to investigation, by Prof. A. Meek, 418.
- SCHÄFER (Sir Edward) *on the ductless glands*, 305.
- \*School-books, the influence of, upon eyesight, report on, 527.
- SCHUSTER (Prof. Arthur) *on seismological investigations*, 29.
- *on radiotelegraphic investigations*, 127.
- *on popular science lectures*, 326.
- *on the work of the Corresponding Societies Committee*, 566.
- \*Science in the universities, by Principal W. H. Hadow, 525.
- †— in relation to industry, by Dr. E. F. Armstrong, 525.
- \*— in secondary schools, the present position of, by J. Talbot, 524.
- in the education of girls, by Dr. Mary H. Williams, 526.
- \*— the place of, in the education of boys, discussion on, 526.
- \*— the place of, in the education of girls, discussion on, 527.
- training which should be given to girls, Mary E. Marsden on the, 526.
- SCOBLE (W. A.) *on stress distributions in engineering materials*, 280.
- SCOTT (Dr. Alexander), the petrology of the Arran pitchstones, 398.
- SCOTT (Prof. W. R.) *on industrial unrest*, 274.
- *on the replacement of men by women in industry*, 276.
- *on the effects of the war on credit, currency, and finance*, 278.
- \*Secondary education for children, a scheme of, by Mrs. T. W. Wallis, 524.
- Seismological investigations, twenty-first report on*, 29.
- SEWARD (Prof. A. C.) *on the nomenclature of the carboniferous, permo-carboniferous, and permian rocks of the southern hemisphere*, 238.
- SHAW (J. J.) *on seismological investigations*, 29.
- SHAW (Sir Napier) *on seismological investigations*, 29.
- *on radiotelegraphic investigations*, 127.
- †Shell-fisheries, the further development of the, by Dr. J. Johnstone, 418.
- SHERRINGTON (Prof. C. S.) *on the structure and function of the mammalian heart*, 304.
- SHRUBSALL (Dr. F. C.) *on the mental and physical factors involved in education*, 307.
- †Similitude in engineering design, the principle of, by Dr. T. E. Stanton, 456.
- SIMON (E. D.) *on fuel economy*, 187.
- SKEATS (Prof. E. W.) *on the nomenclature of the carboniferous, permo-carboniferous, and permian rocks of the southern hemisphere*, 238.
- SLOAN (R. P.) *on fuel economy*, 187.
- †SMALL (J.), geographical distribution of the compositæ, 509.
- SMITH (Prof. H. Bompas) *on the mental and physical factors involved in education*, 307.
- SMITH (H. G.) *on the botanical and chemical characters of the eucalypts and their correlation*, 201.
- SMITH (Dr. W. G.), utilisation of northern mountain and heath land, 498.
- SMITHIELLS (Prof. A.) *on gaseous explosions*, 292.
- \*SMYTHE (Dr. J. A.), a modified chlorination process, 377.
- †Sociology and psychology, by Dr. W. H. R. Rivers, 476.
- \*Soil protozoa and soil bacteria, by Dr. T. Goodey, 547.
- \*Solid nickel and copper oxides, the reduction of, by solid iron, Dr. J. E. Stead on, 376.
- \*Solubility phenomena, the study of, report on, 377.

- †SOMERVILLE (Prof. W.), British forestry, past and future, 547.
- SPEARMAN (Dr. C.) *on the mental and physical factors involved in education*, 307.
- †Spectral lines, the frequencies of, can they be represented as a function of their order? by Prof. W. M. Hicks, 364.
- †— the measurement of the energy in, by Dr. R. T. Beatty, 365.
- \*Spool and shuttle, the weaving, the evolution of, by H. Ling Roth, 468.
- †Standard cubic equation, suggestions for the practical treatment of the, and a contribution to substitution theory, by Prof. R. W. Genese, 365.
- †Standardisation and its influence on the engineering industries, by C. le Maistre, 456.
- STANTON (Dr. T. E.) *on stress distributions in engineering materials*, 280.
- †— the principle of similitude in engineering design, 456.
- Starch in the branches of trees, the distribution of, and its bearing on the statolith theory, Miss T. L. Prankerd on, 511.
- †Stars of different magnitudes, the mean distances of, by Sir F. W. Dyson, 364.
- Statistics and Economic Science, Address to the Section of, by Prof. A. W. Kirkaldy, 435.
- STEAD (Dr. J. E.) *on fuel economy*, 187.
- \*— *on the oxidation of nickel steel*, 376.
- \*— *on the reduction of solid nickel and copper oxides by solid iron*, 376.
- \*— *on the disruptive effect of carbon monoxide at 400° to 500° C. on wrought iron*, 376.
- STEBBING (Rev. T. R. R.) *on the work of the Corresponding Societies Committee*, 566.
- \*Stepped ignition of gases, the, Prof. W. M. Thornton on, 377.
- STEWART (Dr. A. W.) *on the absorption spectra and chemical constitution of organic compounds*, 131.
- STIRLING-MAXWELL (Sir J. S.) *on afforestation after the war*, 505.
- STONEJ (Gerald G.), Address to the Engineering Section, 448.
- STRAHAN (Dr. A.) *on fuel economy*, 187.
- Stress distributions in engineering materials, the more complex, interim report on*, 280.
- STROMEYER (C. E.) *on fuel economy*, 187.
- *on stress distributions in engineering materials*, 280.
- †Sunspots in relation to terrestrial magnetic phenomena, the efficiency of, by Rev. A. L. Cortie, 364.
- †Survey work near Bellingham, by Miss C. E. C. Measham, 511.
- SYKES (E.) *on the effects of the war on credit, currency, and finance*, 278.
- TALBOT (Benjamin) *on fuel economy*, 187.
- \*TALBOT (J.), the present position of science in secondary schools, 524.
- †Taro, the cultivation of, by Dr. W. H. R. Rivers, 468.
- TEALL (Sir J. J. H.) *on the collection of photographs of geological interest*, 218.
- TEMPLE (Rev. W.), Address to the Educational Section, 512.
- †Terrestrial magnetic phenomena, efficiency of sunspots in relation to, by Rev. A. L. Cortie, 364.
- Thick coal of South Staffordshire, the, by W. W. King, 393.
- \*THOMPSON (Prof. W. H.), arginine and creatine formation, 475.
- \*THORNTON (Prof. W. M.) *on the stepped ignition of gases*, 377.
- †— the influence of pressure on the electrical ignition of methane, 456.
- THRELFALL (Prof. R.) *on fuel economy*, 187.
- \*Thyroid, the action of, on the suprarenals and heart, by Prof. P. T. Herring, 475.
- †Thyroid-feeding, the effect of, on the pancreas, by Dr. Kojima, 475.
- \*TOCHER (Dr. J. F.), the anthropometric characters of asylum and normal population, 468.
- \*Transpacific migrations, by Dr. A. Hrdlicka, 469.
- †Tungus, the north-western, the physical type of, by Miss Czaplicka, 469.
- \*TURNER (Miss), some aspects of infancy and childhood in the light of Freudian principles, 476.
- TURNER (Prof. H. H.) *on seismological investigations*, 29.
- *on radiotelegraphic investigations*, 127.
- *on popular science lectures*, 326.
- †— the measurement of time, 364.
- *on the determination of gravity at sea*, 549.
- *on the work of the Corresponding Societies Committee*, 566.
- \*TURNOR (Christopher), outlets for labour on the land, 446.
- TWENTYMAN (A. E.) *on the mental and physical factors involved in education*, 307.
- †Urea and sugar, the secretion of, by the kidney, by Prof. A. R. Cushny, 475.



- VELEY (Prof.) *on electromotive phenomena in plants*, 305.
- VINCENT (Prof. Swale) *on the ductless glands*, 305.
- WACE (A. J. B.) *on the distribution of artificial islands in the lochs of the highlands of Scotland*, 303.
- WALKER (G. Blake) *on fuel economy*, 187.
- WALKER (Dr. G. T.) *on seismological investigations*, 29.
- WALKER (Dr. G. W.) *on seismological investigations*, 29.
- WALLER (Prof. A. D.) *on the occupation of a table at the zoological station at Naples*, 238.
- *on electromotive phenomena in plants*, 305.
- \* — food standards and man power, 475.
- WALLER (Mrs. A. M.) *on electromotive phenomena in plants*, 305.
- \* WALLIS (B. C.), some geographical aspects of a war indemnity, 434.
- \* WALLIS (Mrs. T. W.), a scheme of secondary education for children, 524.
- War, *the effects of the, on credit, currency, and finance, abstract of report on*, 278.
- \* War and eugenics, by Hugh Richardson, 420.
- † War-economy posters, experiments upon the effectiveness of, by Miss Edgell, 476.
- \* War indemnity, a, some geographical aspects of, by B. C. Wallis, 434.
- WARTON (Col. R. Gardner) *on the exploration of La Colte de St. Brelade, Jersey*, 292.
- Waste lands, the utilisation and improvement of, discussion on, 493.
- Prof. F. W. Oliver on, 493.
- Waste moorlands, by Prof. W. B. Bottomley, 501.
- † WATKINSON (Prof. W. H.) on the possibility of working Diesel engines with low compression pressures, 456.
- WATSON (Dr. D. M. S.) *on the excavation of critical sections in the plant-bearing cherts at Rhynie, Aberdeenshire*, 206.
- *on the nomenclature of the carboniferous, permo-carboniferous, and permian rocks of the southern hemisphere*, 238.
- WATSON (Prof. G. N.), oscillating and asymptotic series, 365.
- WATSON (Prof. W.) *on gaseous explosions*, 292.
- \* WATTS (Rev. Arthur), the Witton Gilbert stone axe, 469.
- WATTS (Prof. W. W.) *on the collection of photographs of geological interest*, 218.
- WEBB (W. Mark) *on the work of the Corresponding Societies Committee*, 566.
- WEBSTER (Prof. A. G.) *on the calculation of mathematical tables*, 59.
- \* Weddell Sea, the, by Dr. W. S. Bruce, 433.
- WEISS (Prof. F. E.) *on the renting of Cinchona botanic station in Jamaica*, 307.
- WELCH (R.) *on the collection of photographs of geological interest*, 218.
- \* WESTON (Rev. Walter), recent exploration in the Japanese Alps, 434.
- WHEELER (R. V.) *on fuel economy*, 187.
- WHITAKER (W.) *on the collection of photographs of geological interest*, 218.
- *on the work of the Corresponding Societies Committees*, 566.
- WHITEHEAD (Prof. A. N.), Address to the Mathematical and Physical Section, 355.
- \* WHITTAKER (C. M.), the British coal tar colour industry in peace and war, 376.
- \* WIBBERLEY (T.), climate and tillage, 548.
- WILLIAMS (Prof. J. Lloyd) and G. W. ROBINSON, reclamation of peat-lands in Carnarvonshire, 502.
- WILLIAMS (Dr. Mary H.), science in the education of girls, 526.
- \* WILLIS (Dr. J. C.), are endemics the oldest or the youngest species in a country? 509.
- WILMORE (Dr. A.), the physical geography and geology of the Northern Pennines, 398.
- WILSON (J. S.) *on stress distributions in engineering materials*, 280.
- WIMPERIS (H. E.) *on gaseous explosions*, 292.
- WINDER (B. W.) *on fuel economy*, 187.
- † Witches, organisations of, in Great Britain, by Miss M. Murray, 469.
- \* Witton Gilbert stone axe, the, by Rev. Arthur Watts, 469.
- † WOOD (Prof. T. B.), the composition of British straws, 548.
- † — and K. J. J. MACKENZIE, economy in beef production, 548.
- WOODHOUSE (W. B.) *on fuel economy*, 187.
- \* WOODS (H. C.), Salonika; its geographical relation to the interior, 434.
- WOODWARD (Dr. A. Smith) *on the old red sandstone rocks of Kiltoran, Ireland*, 205.
- † WOOLACOTT (Dr. D.) on the permian of Durham, 393.
- WOOLNOUGH (Prof. W. G.) *on the nomenclature of the carboniferous, permo-carboniferous, and permian rocks of the southern hemisphere*, 238.
- WYNNE (Prof. W. P.) *on fuel economy*, 187.

- †X-ray spectra of the elements, by Sir E. Rutherford, 364.
- YAPP (Prof. R. H.) *on the renting of Cinchona botanic station in Jamaica*, 307.
- †—— the origin and fate of salt-marsh pans, 509.
- YATES (James) *on fuel economy*, 187.
- YOUNG (Prof. Sydney) *on dynamic isomerism*, 130.
- Zoological bibliography and publication, report on*, 239.
- Zoological Section, Address by Prof. E. W. MacBride to the, 403.
- \**Zoological organisation, report on*, 417.
- Zoological station at Naples, report on the occupation of a table at the*, 238.

# BRITISH ASSOCIATION FOR THE ADVANCEMENT OF SCIENCE.

PUBLICATIONS ON SALE AT THE OFFICE OF THE ASSOCIATION,  
BURLINGTON HOUSE, PICCADILLY, LONDON, W.

Life Members (since 1845), and all Annual Members who have not intermitted their subscriptions, receive gratis all Reports (Annual Volumes) published after the date of their membership.

Associates for any Meeting may obtain the Annual Volume relating to that Meeting at two-thirds of the publication price.

The price of any Annual Volume, for the years 1831-1876 inclusive, will be quoted on application to the Office of the Association.

A few sets, from 1831 to 1874 inclusive, are available at £10 per set.

The publication price of each Annual Volume since 1877 is £1 4s.

The President's Address, and Sectional Addresses, bound together, for 1888, 1889, 1890, 1891, 1892, 1893, 1895, 1896, 1899, 1900, 1901, 1902, 1909, 1910 (*paper*), each 1s., 1913, 1914, 1915 (*cloth*), 2s.

Addresses by the *Presidents of the Association* are obtainable (*separately*) for several years after 1860, and for all years since 1901, each 3d.

Many of the *Sectional Presidents' Addresses* are obtainable separately for years since 1864, each 3d.

Lithographed Signatures of the Members who met at Cambridge in 1833, with the Proceedings of the Public Meetings, 4to, 4s.

Index to the Reports, 1831-1860, 12s. (carriage included).

Index to the Reports, 1861-1890, 15s. (carriage, 5d.).

Lalande's Catalogue of Stars, £1 1s.

Stellar Distribution and Movements, by A. S. Eddington, M.Sc., 1911, 3d.

Report of the International Conference on Terrestrial Magnetism and Atmospheric Electricity, 1898, 6d.

Preliminary Report on the Magnetic Survey of South Africa, 1906, 3d.

Report on Seismology, 1900, 1s.; 1901, 1s.; 1902, 1s.; 1903, 1s.; 1904, 1s.; 1905, 1s.; 1906, 6d.; 1907, 6d.; 1908, 1s.; 1909, 1s.; 1910, 1s.; 1911, 1s.; 1912, 1s.; 1913, 1s.; 1914, 1s.; 1915, 1s.

Catalogue of Destructive Earthquakes, A.D. 7 to A.D. 1899, by Dr. J. Milne, F.R.S., 1912, 5s.

Report of the Committee for constructing and issuing Practical Standards for use in Electrical Measurements, 1892, 6d.; 1893, 6d.; 1894, 1s.; 1895, 6d.; 1899, 6d.; 1903, 6d.; 1904, 6d.; 1905, 6d.; 1906, 6d.; 1907, 6d.; 1908, 6d.; 1909, 3d. (The complete Reports of this Committee have been reprinted, demy 8vo., 12s. 6d., Cambridge University Press.)

- The Action of Magnetism on Light, by J. Larmor, F.R.S., 1893, 1s.  
 Report on the Present State of our Knowledge of Thermodynamics, Part II., by G. H. Bryan; with an Appendix by Prof. L. Boltzmann, 1894, 1s.  
 Report on the Comparison of Magnetic Instruments, 1896, 4d.  
 Report on the Bibliography of Spectroscopy in continuation of 1894 Report, 1898, 1s. 6d.; 1901, 1s. 6d.  
 Note sur l'Unité de Pression, par le Dr. C. E. Guillaume, 1901, 3d.  
 Note on the Variation of the Specific Heat of Water, by Prof. H. L. Callendar, 1901, 4d.  
 On Threefold Emission Spectra of Solid Aromatic Compounds, by Prof. E. Goldstein, 1909, 3d.  
 Anode Rays and their Spectra, by Dr. Otto Reichenheim, 1909, 3d.  
 The Principle of Relativity, by E. Cunningham, 1911, 3d.  
 Report on the Determination of Gravity at Sea, 1916, 1s.
- 
- Report on Tables of the Bessel Functions, 1896, 1s.  
 Tables of  $F(r, \nu)$  and  $H(r, \nu)$  Functions, 1899, 1s.  
 The History and Present State of the Theory of Integral Equations, by H. Bateman, 1910, 1s. 6d.
- 
- Report on Electrolysis, 1886, 1s.; 1887, 6d.; 1888, 6d.  
 Report on the Present State of our Knowledge of Electrolysis and Electro-chemistry, 1893, 6d.  
 Discussion on the Theory of Solution, 1890, 6d.
- 
- Report on Wave-lengths, 1899, 1s.; 1900, with Index to Tables from 1884 to 1900, 1s.; 1901, 1s.  
 Report on the Chemical Compounds contained in Alloys, by F. H. Neville, F.R.S., 1900, 6d.  
 The Constitution of Camphor, by A. Lapworth, D.Sc., 1900, 1s.  
 Report on Absorption Spectra and Chemical Constitution of Organic Substances, 1901, 1s.  
 The Relative Progress of the Coal-tar Industry in England and Germany during the past Fifteen Years, by Arthur G. Green, 1901, 6d.  
 The Methods for the Determination of Hydrolytic Dissociation of Salt Solutions, by R. C. Farmer, 1901, 6d.  
 The Application of the Equilibrium Law to the Separation of Crystals from Complex Solutions and to the Formation of Oceanic Salt Deposits, by Dr. E. Frankland Armstrong, 1901, 1s.  
 Our Present Knowledge of Aromatic Diazo-compounds, by Dr. Gilbert Thomas Morgan, 1902, 6d.  
 The Present Position of the Chemistry of Rubber, by S. S. Pickles, 1906, 6d.  
 The Present Position of the Chemistry of Gums, by H. Robinson, 1906, 3d.  
 The Sensitiveness of Indicators, by H. T. Tizard, 1911, 3d.  
 Diffusion in Solids, by Dr. C. H. Desch, 1912, 3d.  
 Solubility, by J. Vargas Eyre, Ph.D. Part I., 1910, 1s.; Part II., 1913, 1s.  
 Report on the Absorption Spectra and Chemical Constitution of Organic Compounds, 1916, 1s.
- 
- Report on the Character of the High-level Shell-bearing Deposits at Clava, Chapelhall, and other Localities, 1893, 6d.  
 Fourth Report on the Erosion of the Sea Coast of England and Wales, 1895, 9d.  
 Report on the Changes in the Sea Coast, 1903, 1s.  
 Report on the Structure of Crystals, 1901, 1s.

- Report on Life-zones in the British Carboniferous Rocks, 1901, 6*d.* ; 1902, 6*d.* ; 1904, 6*d.*
- The Formation of ' Rostro-Carinate ' Flints, by Professor W. J. Sollas, F.R.S., 1913, 3*d.*
- Missing Links among Extinct Animals, by Dr. A. Smith Woodward, 1913, 3*d.*
- 
- Rules of Zoological Nomenclature, 1*s.*
- Digest of Observations on the Migration of Birds, made at Lighthouses, by W. Eagle Clarke, 1896, 6*d.*
- Report on the Migratory Habits of the Song-thrush and the White Wagtail, by W. Eagle Clarke, 1900, 6*d.*
- Report on the Migratory Habits of the Skylark and the Swallow, by W. Eagle Clarke, 1901, 6*d.*
- Report on the Migratory Habits of the Fieldfare and the Lapwing, by W. Eagle Clarke, 1902, 6*d.*
- Report on the Migratory Habits of the Fieldfare and the Lapwing, by W. Eagle Clarke, 1903, 6*d.*
- Melanism in Yorkshire Lepidoptera, by G. T. Porritt, 1906, 6*d.*
- Report on the Biological Problems incidental to the Belmullet Whaling Station, 1912, 3*d.* ; 1914, 1*s.*
- On the Phylogeny of the Carapace, and on the Affinities of the Leathery Turtle, *Dermochelys coriacea*, by Dr. J. Versluys, 1913, 6*d.*
- On the Regulation of Wages by means of Lists in the Cotton Industry :—Spinning, 2*s.* ; Weaving, 1*s.*
- Report on Future Dealings in Raw Produce, 1900, 6*d.*
- Report on Women's Labour, 1903, 6*d.*
- Report on the Accuracy and Comparability of British and Foreign Statistics of International Trade, 1904, 6*d.*
- Report on the Amount and Distribution of Income (other than Wages) below the Income-tax Exemption Limit in the United Kingdom, 1910, 6*d.*
- Report on the Effects of the War on Credit, Currency, and Finance, 1915, 6*d.*
- Report on the Question of Fatigue from the Economic Standpoint, 1915, 6*d.*
- Report on Outlets for Labour after the War, 1915, 6*d.*
- Second Report on the Development of Graphic Methods in Mechanical Science, 1892, 1*s.*
- Report on Planimeters, by Prof. O. Henrici, F.R.S., 1894, 1*s.*
- Second Report on a Gauge for Small Screws, 1884, reprinted 1895, 6*d.*
- Report on giving practical effect to the Introduction of the British Association Screw Gauge, 1896, 6*d.* ; 1901, 6*d.* ; 1903, 6*d.*
- Report on Proposed Modification of the Thread of the B.A. Screw, 1900, 6*d.*
- Report on the Resistance of Road Vehicles to Traction, 1901, 3*d.*
- The Road Problem, by Sir J. H. A. Macdonald, 1912, 3*d.*
- Standardisation in British Engineering Practice, by Sir John Wolfe-Barry, K.C.B., 1906, 3*d.*
- Report on the Investigation of Gaseous Explosions, with special reference to Temperature, 1909, 6*d.* ; 1910, 3*d.* ; 1912, 3*d.*
- Gaseous Combustion, by William Arthur Bone, D.Sc., F.R.S., 1910, 6*d.*
- The Present Position of Electric Steel Melting, by Professor A. McWilliam, 1911, 3*d.*

Discussion on the Proper Utilisation of Coal, and Fuels derived therefrom, 1913, 6*d.*  
Liquid, Solid, and Gaseous Fuels for Power Production, by Professor F. W. Burstall,  
1913, 3*d.*

---

Report on the Ethnographical Survey of the United Kingdom, 1893, 6*d.* ; 1894, 6*d.*  
Report on Anthropometric Investigation in the British Isles, 1906, 1*s.* ; 1907, 3*d.*  
Fifth to Twelfth Reports on the North-Western Tribes of Canada, 1889, 1*s.* ; 1890,  
2*s.* 6*d.* ; 1891, 1*s.* ; 1892, 1*s.* ; 1894, 6*d.* ; 1895, 1*s.* 6*d.* ; 1896, 6*d.* ; 1898, 1*s.* 6*d.*  
Report on the Ethnological Survey of Canada, 1899, 1*s.* 6*d.* ; 1900, 1*s.* 6*d.* ; 1902, 1*s.*  
Report on Artificial Islands in the Lochs of the Highlands of Scotland, 1912, 3*d.*  
Report on the Archæological and Ethnological Researches in Crete, 1910, 6*d.* ; 1912, 6*d.*  
Report on Physical Characters of the Ancient Egyptians, 1914, 6*d.*

---

The Claim of Sir Charles Bell to the Discovery of Motor and Sensory Nerve Channels  
(an Examination of the Original Documents of 1811-1830), by Dr. A. D. Waller,  
F.R.S., 1911, 6*d.*

Heat Coagulation of Proteins, by Dr. Chick and Dr. Martin, 1911, 3*d.*

---

The Influence of the Universities on School Education, by the Right Rev. John  
Percival, D.D., Lord Bishop of Hereford, 1901, 3*d.*

Report on the Curricula of Secondary Schools, 1907, 3*d.*

Report on Mental and Physical Factors involved in Education, 1910, 3*d.* ; 1911, 3*d.*  
1912, 3*d.*

Report on the Influence of School Books upon Eyesight, 1913 (Second Edition  
revised), 4*d.*

Report on the number, distribution, and respective values of Scholarships, Exhibi-  
tions, and Bursaries held by University students during their undergraduate  
course, and on funds private and open available for their augmentation, 1913, 3*d.*

Report on the best means for promoting Scientific Education in Schools, 1867, 6*d.*

Report on the Sequence of Studies in the Science Section of the Curriculum of Secondary  
Schools, 1908, 3*d.*

Second Report on the present Methods of Teaching Chemistry, 1889, 6*d.*

Report on the Teaching of Elementary Mathematics, 1902, 3*d.*

Report on the Teaching of Botany in Schools, 1903, 3*d.*

Report on the Position of Geography in the Educational System of the Country, 1897,  
6*d.*

Report on Geographical Teaching in Scotland, 1913, 3*d.*

---

Discussion on Agriculture and Science, Ipswich, 1895, 3*d.*

The Development of Wheat Culture in North America, by Professor A. P. Brigham,  
1909, 3*d.*

---

A number of shorter Reports, etc., for recent years, in addition to the above, are also  
available in separate form ; inquiries should be addressed to the Office.

BRITISH ASSOCIATION  
FOR THE ADVANCEMENT OF SCIENCE  
1916



LIST OF MEMBERS  
OFFICERS AND COUNCIL  
AND  
INSTITUTIONS RECEIVING THE REPORT

CORRECTED TO MARCH 1917.

LONDON:  
BURLINGTON HOUSE, PICCADILLY, W.

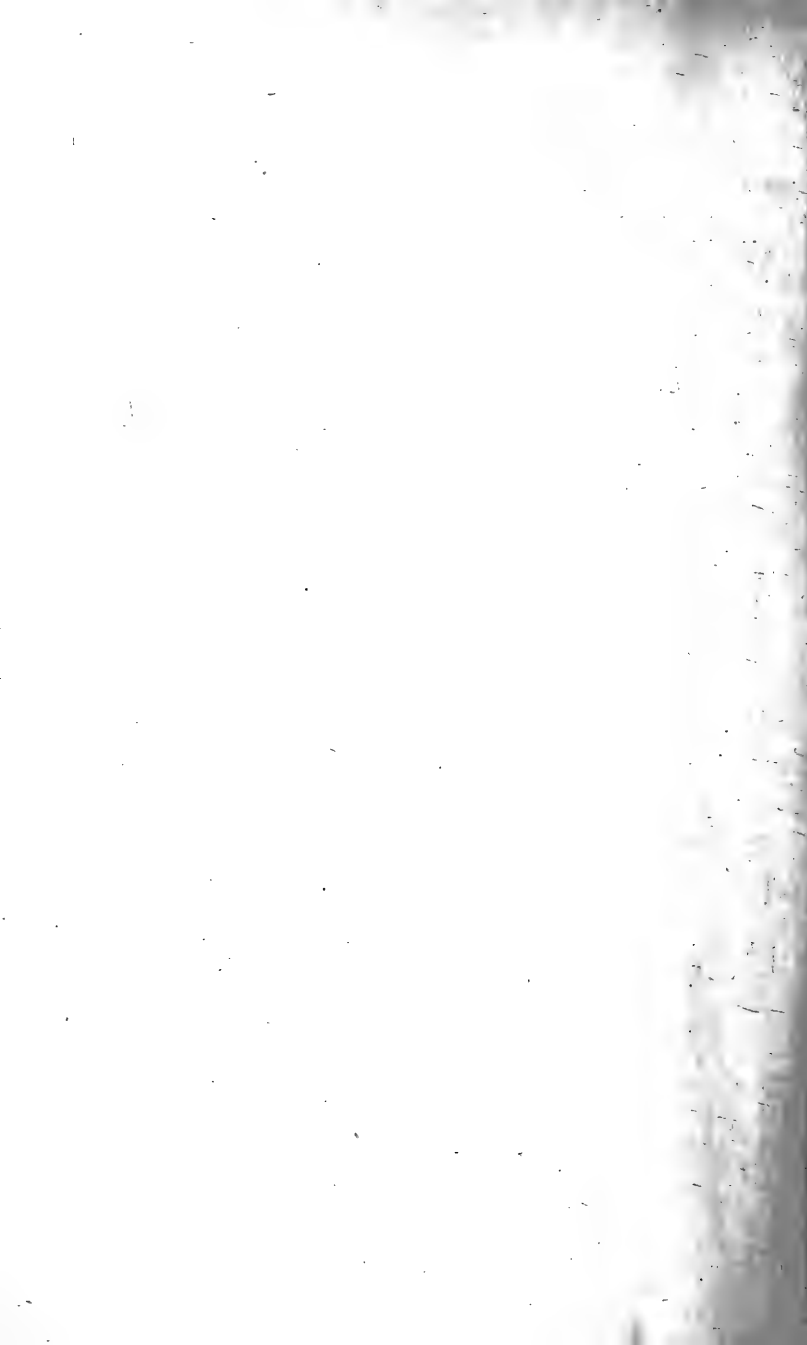



# OFFICERS AND COUNCIL, 1916-1917.

## PATRON.

HIS MAJESTY THE KING.

## PRESIDENT.

SIR ARTHUR EVANS, D.LITT., LL.D., PRES.S.A., F.R.S.

## VICE-PRESIDENTS.

The Right Hon. the Lord Mayor of Newcastle.	The Right Hon. LORD RAVENSWORTH.
His Grace the DUKE OF NORTHUMBERLAND, K.G., F.R.S.	The Right Hon. LORD ARMSTRONG.
The Right Hon. the MARQUIS OF LONDONDERRY, M.V.O.	The Right Hon. LORD JOICEY.
The Right Hon. the EARL OF DURHAM, K.G., G.O.V.O.	The Right Rev. the Lord Bishop of Durham, D.D.
The Right Hon. the EARL OF CRAVEN.	The Right Hon. J. W. LOWTHER, M.P.
The Right Hon. the EARL GREY, G.C.B., G.O.M.G., G.O.V.O.	The Right Hon. W. RUNCIMAN, M.P.
The Right Hon. VISCOUNT ALLENDALE.	Sir HUGH BELL, Bart.
The Right Hon. VISCOUNT GREY, K.G.	The Hon. Sir CHARLES PARSONS, K.C.B., D.C.L., F.R.S.
The Right Hon. LORD BARNARD.	Sir GEORGE H. PHILIPSON, M.D., D.C.L.
	Principal W. H. HADDOY, D.Mus.

## PRESIDENT ELECT.

Hon. Sir CHARLES A. PARSONS, K.C.B., Sc.D., F.R.S.

## GENERAL TREASURER.

Professor JOHN PERRY, D.Sc., LL.D., F.R.S., Burlington House, London, W.

## GENERAL SECRETARIES.

Professor W. A. HERDMAN, D.Sc., LL.D., F.R.S. | Professor H. H. TURNER, D.Sc., D.C.L., F.R.S.

## ASSISTANT SECRETARY.

O. J. R. HOWARTH, M.A., Burlington House, London, W.

## CHIEF CLERK AND ASSISTANT TREASURER.

H. O. STEWARDSON, Burlington House, London, W.

## ORDINARY MEMBERS OF THE COUNCIL.

BONE, Professor W. A., F.R.S.	HALLIBURTON, Professor W. D., F.R.S.
BRABROOK, Sir EDWARD, C.B.	HARMER, Dr. S. F., F.R.S.
BRAGG, Professor W. H., F.R.S.	IM THURN, Sir E. F., K.O.M.G.
CLERK, Dr. DUGALD, F.R.S.	MORRIS, Sir D., K.C.M.G.
DENDY, Professor A., F.R.S.	RUSSELL, Dr. E. J.
DICKSON, Professor H. N., D.Sc.	RUTHERFORD, Sir E., F.R.S.
DIXEY, Dr. F. A., F.R.S.	SAUNDERS, Miss E. R.
DIXON, Professor H. B., F.R.S.	SCOTT, Professor W. R.
DYSON, Sir F. W., F.R.S.	STARLING, Professor E. H., F.R.S.
GREGORY, Professor R. A.	STRAHAN, Dr. A., F.R.S.
GRIFFITHS, Principal E. H., F.R.S.	WEISS, Professor F. R., D.Sc.
HADDON, Dr. A. O., F.R.S.	WOODWARD, Dr. A. SMITH, F.R.S.

## EX-OFFICIO MEMBERS OF THE COUNCIL.

The Trustees, past Presidents of the Association, the President and Vice-Presidents for the year, the President and Vice-Presidents Elect, past and present General Treasurers and General Secretaries, past Assistant General Secretaries, and the Local Treasurers and Local Secretaries for the ensuing Annual Meeting.

## OFFICERS AND COUNCIL

## TRUSTEES (PERMANENT).

The Right Hon. Lord RAYLEIGH, O.M., M.A., D.C.L., LL.D., F.R.S., F.R.A.S.  
 Major P. A. MACMAHON, D.Sc., LL.D., F.R.S., F.R.A.S.  
 Dr. G. CAREY FOSTER, LL.D., D.Sc., F.R.S.

## PAST PRESIDENTS OF THE ASSOCIATION.

Lord Rayleigh, O.M., F.R.S.	Arthur J. Balfour, O.M., F.R.S.	Sir E. A. Schäfer, F.R.S.
Sir A. Geikie, K.O.B., O.M., F.R.S.	Sir E. Ray Lankester, K.O.B., F.R.S.	Sir Oliver Lodge, F.R.S.
Sir W. Crookes, O.M., F.R.S.	Sir Francis Darwin, F.R.S.	Professor W. Bateson, F.R.S.
Sir James Dewar, F.R.S.	Sir J. J. Thomson, O.M., Pres.R.S.	Professor A. Schuster, F.R.S.
Sir Norman Lockyer, K.C.B., F.R.S.	Professor T. G. Bonney, F.R.S.	

## PAST GENERAL OFFICERS OF THE ASSOCIATION.

Professor T. G. Bonney, F.R.S.	Sir E. A. Schäfer, F.R.S.	Dr. J. G. Garson.
Dr. A. Vernon Harcourt, F.R.S.	Dr. D. H. Scott, F.R.S.	Major P. A. MacMahon, F.R.S.
	Dr. G. Carey Foster, F.R.S.	

## AUDITORS.

Sir Edward Brabrook, C.B. | Sir Everard im Thurn, O.B., K.O.M.G.

---

LIST OF MEMBERS  
OF THE  
BRITISH ASSOCIATION FOR THE ADVANCEMENT  
OF SCIENCE.  
1916.

---

- \* indicates Life Members entitled to the Annual Report.  
 § indicates Annual Subscribers entitled to the Annual Report.  
 † indicates Subscribers not entitled to the Annual Report.  
 Names without any mark before them are Life Members, elected before 1845, not entitled to the Annual Report.  
 Names of Members of the GENERAL COMMITTEE are printed in SMALL CAPITALS.  
 Names of Members whose addresses are incomplete or not known are in *italics*.
- 

*Notice of changes of residence should be sent to the Assistant Secretary,  
Burlington House, London, W.*

---

Year of  
Election.

1905. \*à-Ababrelton, Robert, F.R.G.S., F.S.S. P.O. Box 322, Pietermaritzburg, Natal. Care of Royal Colonial Institute, Northumberland-avenue, W.C.
1914. †Abbott, Hon. R. H. S. Rowan-street, Bendigo, Victoria.
1881. \*Abbott, R. T. G. Whitley House, Malton.
1885. \*ABERDEEN, The Marquis of, G.C.M.G., LL.D. Haddo House, Aberdeen.
1885. †Aberdeen, The Marchioness of. Haddo House, Aberdeen.
1873. \*ABNEY, Captain Sir W. DE W., K.C.B., D.C.L., F.R.S., F.R.A.S. (Pres. A, 1889; Pres. L, 1903; Council, 1884-89, 1902-05, 1906-12.) Measham Hall, Leicestershire.
1869. †Acland, Sir C. T. Dyke, Bart., M.A. Killerton, Exeter.
1877. \*Acland, Captain Francis E. Dyke, R.A. Walwood, Banstead, Surrey.
1894. \*ACLAND, HENRY DYKE, F.G.S., F.S.A. Chy-an-Mor, Gyllyngvase, Falmouth.
1877. \*Acland, Theodore Dyke, M.D. 19 Bryanston-square, W.
1904. †Acton, T. A. 41 Regent-street, Wrexham.
1898. †ACWORTH, W. M., M.A. (Pres. F, 1908.) The Albany, W.
1915. †Adam, Sir Frank Forbes, C.I.E., LL.D. Hankelow Court, Audlem.
- 1916.

Year of  
Election.

1901. †*Adam, J. Miller.* 15 *Walmer-crescent, Glasgow.*  
 1915. §*Adams, M. Atkinson.* *The White Cottage, Knutsford.*  
 1887. †*ADAM, J. G., M.A., M.D., F.R.S.,* Professor of Pathology in  
 McGill University, Montreal, Canada.  
 1901. §*ADAMS, JOHN, M.A., B.Sc., LL.D. (Pres. L, 1912),* Professor of  
 Education in the University of London. 23 Tanza-road,  
 Hampstead, N.W.  
 1904. †*Adams, W. G. S., M.A.* Department of Agriculture, Upper  
 Merrion-street, Dublin.  
 1908. \**Adamson, R. Stephen.* The University, Manchester.  
 1913. †*Addison, W. H. F.* Medical School, The University of Penn-  
 sylvania.  
 1890. †*ADENEY, W. E., D.Sc., F.C.S.* Burnham, Monkstown, Co. Dublin.  
 1899. \**Adie, R. H., M.A., B.Sc.* 136 Huntingdon-road, Cambridge.  
 1908. §*Adkin, Robert.* 4 Lingard's-road, Lewisham, S.E.  
 1912. †*Afanassieff, Apollo.* Physical Institute, Imperial University,  
 Petrograd.  
 1908. \**Agar, W. E., M.A.* Natural History Department, The University,  
 Glasgow.  
 1902. †*Agnew, Samuel, M.D.* Bengal-place, Lurgan.  
 1871. \**Ainsworth, Sir John Stirling, Bart., M.P.* Harecroft, Gosforth,  
 Cumberland.  
 1909. \**AIRD, JOHN.* Canadian Bank of Commerce, Toronto, Canada.  
 1914. †*Airey, J. W.* Barooma, Vernon-street, Strathfield, Sydney.  
 1911. §*Airey, John R., M.A., B.Sc.* 73 Claremont-road, Forest Gate, E.  
 1895. \**Airy, Hubert, M.D.* Stoke House, Woodbridge, Suffolk.  
 1891. \**Aisbitt, M. W.* Mountstuart-square, Cardiff.  
 1871. §*AITKEN, JOHN, LL.D., F.R.S., F.R.S.E.* Ardenlea, Falkirk, N.B.  
 1901. †*Aitken, Thomas, M.Inst.C.E.* County Buildings, Cupar-Fife.  
 1884. \**Alabaster, H.* Milton, Grange-road, Sutton, Surrey.  
 1905. †*Albright, Miss.* Finstal Farm, Finstal, Bromsgrove, Worcestershire.  
 1886. \**Albright, G. S.* Broomsberrow Place, Ledbury.  
 1913. †*Albright, W. A.* 29 Frederick-road, Edgbaston, Birmingham.  
 1900. \**Aldren, Francis J., M.A.* The Lizans, Malvern Link.  
 1896. §*Aldridge, J. G. W., Assoc.M.Inst.C.E.* 39 Victoria-street, West-  
 minster, S.W.  
 1905. \**Alexander, J. Abercromby.* 24 Lawn-crescent, Kew.  
 1888. \**Alexander, Patrick Y.* 3 Whitehall-court, S.W.  
 1910. \**Alexander, W. B., B.A.* Western Australian Museum, Perth,  
 West Australia.  
 1891. \**Alford, Charles J., F.G.S.* Hotel Victoria, Rome.  
 1883. †*Alger, W. H.* The Manor House, Stoke Damerel, South Devon.  
 1883. †*Alger, Mrs. W. H.* The Manor House, Stoke Damerel, South Devon.  
 1914. †*Allan, Edward F., B.A.* 37 Wattle-tree-road, Malvern, Victoria.  
 1901. \**Allan, James A.* 21 Bothwell-street, Glasgow.  
 1904. \**Allcock, William Burt.* Emmanuel College, Cambridge.  
 1879. \**Allen, Rev. A. J. C.* 34 Lensfield-road, Cambridge.  
 1898. §*ALLEN, Dr. E. J., F.R.S.* The Laboratory, Citadel Hill, Plymouth.  
 1891. †*Allen, H. A., F.G.S.* 28 Jermyn-street, S.W.  
 1915. †*Allen, J. E.* 23 Cottenham Park-road, Wimbledon, S.W.  
 1907. \**Allorge, M. M., L. ès Sc., F.G.S.* Villa St. Germain, Louviers,  
 France.  
 1912. \**Allworthy, S. W., M.A., M.D.* The Manor House, Antrim-road,  
 Belfast.  
 1887. †*Alward, G. L.* Enfield Villa, Waltham, Grimsby, Yorkshire.  
 1915. †*Ambler, Clement.* 34 Seymour-grove, Old Trafford.  
 1883. §*Amery, John Sparke.* Druid, Ashburton, Devon.

Year of  
Election.

1909. †Ami, H. M., M.D. Ottawa, Canada.  
 1884. †Amr, HENRY, M.A., D.Sc., F.G.S. Geological Survey, Ottawa, Canada.  
 1914. §Anderson, Miss Adelaide M. Home Office, S.W.  
 1910. †Anderson, Alexander. Tower House, Dore, near Sheffield.  
 1905. \*Anderson, C. L. P.O. Box 2162, Johannesburg.  
 1912. †Anderson, E. M. 43 *Ladysmith-road*, Edinburgh.  
 1908. †Anderson, Edgar. Glenavon, Merrion-road, Dublin.  
 1885. \*ANDERSON, HUGH KERR, M.A., M.D., F.R.S. Caius College, Cambridge.  
 1914. †Anderson, J. R. V. School of Mines, Bendigo, Victoria.  
 1901. \*Anderson, James. 166 Buchanan-street, Glasgow.  
 1892. †Anderson, Joseph, LL.D. 8 Great King-street, Edinburgh.  
 1899. \*Anderson, Miss Mary Kerr. 13 Napier-road, Edinburgh.  
 1888. \*Anderson, R. Bruce. 5 Westminster-chambers, S.W.  
 1914. §Anderson, Valentine G. Victoria-avenue, Canterbury, Victoria, Australia.  
 1901. \*Anderson, Dr. W. Carrick. 7 Scott-street, Garnethill, Glasgow.  
 1908. †Anderson, William. Glenavon, Merrion-road, Dublin.  
 1911. †Andrade, E. N. da C. University College, Gower-street, W.C.  
 1907. †Andrews, A. W. Adela-avenue, West Barnes-lane, New Malden, Surrey.  
 1909. †Andrews, Alfred J. Care of Messrs. Andrews, Andrews, & Co., Winnipeg, Canada.  
 1895. †ANDREWS, CHARLES W., B.A., D.Sc., F.R.S. British Museum (Natural History), S.W.  
 1914. §Andrews, E. C. Geological Branch, Department of Mines, Sydney, N.S.W.  
 1909. †Andrews, G. W. 433 Main-street, Winnipeg, Canada.  
 1880. \*Andrews, Thornton, M.Inst.C.E. Cefn Eithen, Swansea.  
 1912. †Angus, Miss Mary. 354 Blackness-road, Dundee.  
 1886. †Ansell, Joseph. 27 Bennett's-hill, Birmingham.  
 1916. \*Anthony, Charles, F.R.S.E., M.Inst.C.E. 149 Bahia Blanca, Argentina.  
 1901. †Arakawa, Minozi. Japanese Consulate, 1 Broad Street-place, E.C.  
 1900. \*ARBER, E. A. NEWELL, M.A., F.L.S. 52 Huntingdon-road, Cambridge.  
 1904. \*ARBER, Mrs. E. A. NEWELL, D.Sc., F.L.S. 52 Huntingdon-road, Cambridge.  
 1913. †Archer, J. Hillside, Crowcombe, West Somerset.  
 1913. \*Archer, R. L., M.A., Professor of Education in University College, Bangor. Plas Menai, Bangor.  
 1894. †Archibald, A. Holmer, Court-road, Tunbridge Wells.  
 1909. †Archibald, Professor E. H. Chemistry Department, University of British Columbia, Vancouver, B.C., Canada.  
 1909. †Archibald, H. Care of Messrs. Machray, Sharpe, & Dennistoun, Bank of Ottawa Chambers, Winnipeg, Canada.  
 1883. \*Armistead, William. Hillcrest, Oaken, Wolverhampton.  
 1908. †Armstrong, E. C. R., M.R.I.A., F.R.G.S. 73 Park-avenue, Sydney-parade, Dublin.  
 1903. \*ARMSTRONG, E. FRANKLAND, D.Sc., Ph.D. Greenbank, Greenbank-road, Latchford, Warrington.  
 1873. \*ARMSTRONG, HENRY E., Ph.D., LL.D., F.R.S. (Pres. B, 1885, 1909; Pres. L, 1902; Council, 1899-1905, 1909-16.) 55 Granville-park, Lewisham, S.E.  
 1909. †Armstrong, Hon. Hugh. Parliament Buildings, Kennedy-street, Winnipeg, Canada.

Year of  
Election.

1905. †Armstrong, John. Kamfersdam Mine, near Kimberley, Cape Colony.
1905. †ARNOLD, J. O., F.R.S., Professor of Metallurgy in the University of Sheffield.
1893. \*ARNOLD-BEMROSE, H. H., Sc.D., F.G.S. Ash Tree House, Osmaston-road, Derby.
1915. †Arnold-Bernard, Pierre. 662 West End-avenue, New York City, U.S.A.
1904. †Arunachalam, P. Ceylon Civil Service, Colombo, Ceylon.
1870. \*Ash, Dr. T. Linnington. Penroses, Holsworthy, North Devon.
1903. \*ASHBY, THOMAS, M.A., D.Litt. The British School, Rome.
1909. †Ashdown, J. H. 337 Broadway, Winnipeg, Canada.
1916. §Ashley, Miss Anne, M.A. 3 Yateley-road, Edgbaston, Birmingham.
1907. †ASHLEY, W. J., M.A. (Pres. F, 1907), Professor of Commerce in the University of Birmingham. 3 Yateley-road, Edgbaston, Birmingham.
1915. \*Ashton, Miss Margaret. 8 Kinnaird-road, Withington, Manchester.
1915. §Ashworth, Arthur. Ellerslie, Walmersley-road, Bury.
1903. \*Ashworth, J. H., D.Sc. 69 Braid-avenue, Edinburgh.
1914. \*Ashworth, Mrs. J. H. 69 Braid-avenue, Edinburgh.
1890. †Ashworth, J. Reginald, D.Sc. 55 King-street South, Rochdale.
1915. §Ashworth, John. 77 King-street, Manchester.
1916. \*Ashworth, John H. The Bungalow, 151 St. Andrew's-road South, St. Anne's-on-Sea.
1875. \*Aspland, W. Gaskell. Care of Messrs. Boustead & Clarke, Mombasa, East Africa.
1905. †Assheton, Mrs. Grantchester, Cambridge.
1908. §ASTLEY, Rev. H. J. DUKINFELD, M.A., Litt.D. East Rudham Vicarage, King's Lynn.
1898. \*Atkinson, E. Cuthbert. 5 Pembroke-vale, Clifton, Bristol.
1894. \*Atkinson, Harold W., M.A. West View, Eastbury-avenue, Northwood, Middlesex.
1906. †Atkinson, J. J. Cosgrove Priory, Stony Stratford.
1907. †Atkinson, Robert E. Morland-avenue, Knighton, Leicester.
1881. †ATKINSON, ROBERT WILLIAM, F.C.S., F.I.C. (Local Sec. 1891.) 10 North Church-street, Cardiff.
1906. §AUDEN, G. A., M.A., M.D. 13 Broughton-drive, Grassendale, Liverpool.
1907. §Auden, H. A., D.Sc. 13 Broughton-drive, Grassendale, Liverpool.
1903. †AUSTIN, CHARLES E. 37 Cambridge-road, Southport.
1912. §Austin, Percy C., M.A., D.Sc. 24 Kiln-lane, St. Helens, Lancashire.
1914. †Avery, D., M.Sc. Collins House, Collins-street, Melbourne.
1909. †Axtell, S. W. Stobart Block, Winnipeg, Canada.
1914. †Baber, Z., Professor of Geography and Geology in the University of Chicago, U.S.A.
1883. \*Bach-Gladstone, Madame Henri. 147 Rue de Grenelle, Paris.
1863. †Backhouse, T. W. West Hendon House, Sunderland.
1883. \*Backhouse, W. A. St. John's, Wolsingham, R.S.O., Durham.
1887. \*Bacon, Thomas Walter. Ramsden Hall, Billericay, Essex.
1903. †Baden-Powell, Major B. 32 Prince's-gate, S.W.

Year of  
Election.

1907. §Badgley, Colonel W. F., Assoc.Inst.C.E., F.R.G.S. Verecroft, Devizes.
1914. †Bage, Charles, M.A., M.D. 139 Collins-street, Melbourne.
1914. †Bage, Miss Freda. Women's College, Brisbane, Australia.
1908. \*Bagnall, Richard Siddoway, F.L.S. Penshaw Lodge, Penshaw, Co. Durham.
1905. †Baikie, Robert. P.O. Box 36, Pretoria, South Africa.
1883. †Baildon, Dr. 42 Houghton-street, Southport.
1883. \*Bailey, Charles, M.Sc., F.L.S. Haymesgarth, Cleeve Hill S.O., Gloucestershire.
1887. \*Bailey, G. H., D.Sc., Ph.D. Edenmor, Kinlochleven, Argyll, N.B.
1905. \*Bailey, Harry Percy. Montrose, Northdown, Margate.
1914. †Bailey, P. G. 4 Richmond-road, Cambridge.
1905. †Bailey, Right Hon. W. F., C.B. Land Commission, Dublin.
1894. \*BAILY, FRANCIS GIBSON, M.A. Newbury, Colinton, Midlothian.
1878. †BAILY, WALTER. 4 Rosslyn-hill, Hampstead, N.W.
1914. †Bainbridge, F. A., M.D., Professor of Physiology in the University of Durham, Newcastle-on-Tyne.
1905. \*Baker, Sir Augustine. 56 Merrion-square, Dublin.
1913. \*Baker, Bevan B., B.Sc. Frontenac, Donnington-road, Harlesden, N.W.
1910. †BAKER, H. F., Sc.D., F.R.S. (Pres. A, 1913), Lowndean Professor of Astronomy and Geometry in the University of Cambridge. St. John's College, Cambridge.
1886. §Baker, Harry, F.I.C. Epworth House, Moughland-lane, Runcorn.
1914. †Baker, R. T. Technological Museum, Sydney, N.S.W.
1915. \*Baker, Miss S. M., D.Sc. Frontenac, Donnington-road, Harlesden, N.W.
1913. †Baker, *Ralph Homfeld. Cambridge.*
1907. †Baldwin, Walter. 382 Brunshaw Top, Burnley.
1904. †BALFOUR, The Right Hon. A. J., O.M., D.C.L., LL.D., M.P., F.R.S., Chancellor of the University of Edinburgh. (PRESIDENT, 1904.) Whittingehame, Prestonkirk, N.B.
1894. †BALFOUR, HENRY, M.A. (Pres. H, 1904.) Langley Lodge, Headington Hill, Oxford.
1905. †Balfour, Mrs. H. Langley Lodge, Headington Hill, Oxford.
1875. †BALFOUR, ISAAC BAYLEY, M.A., D.Sc., M.D., F.R.S., F.R.S.E., F.L.S. (Pres. D, 1894; Pres. K, 1901), Professor of Botany in the University of Edinburgh. Inverleith House, Edinburgh.
1883. †Balfour, Mrs. I. Bayley. Inverleith House, Edinburgh.
1905. †Balfour, Mrs. J. Dawyck, Stobo, N.B.
1905. †Balfour, Lewis. 11 Norham-gardens, Oxford.
1905. †Balfour, Miss Vera B. Dawyck, Stobo, N.B.
1913. \*Ball, Sidney, M.A. St. John's College, Oxford.
1908. †Ball, T. Elrington. 6 Wilton-place, Dublin.
1883. \*Ball, W. W. Rouse, M.A. Trinity College, Cambridge.
1914. §Balsillie, J. Greene. P.M.G.'s Department, Melbourne.
1917. §Baly, E. C. C., M.Sc., F.R.S., Professor of Inorganic Chemistry in the University of Liverpool.
1890. †Bamford, *Professor Harry, M.Sc. 30 Falkland-mansions, Glasgow.*
1909. †Bampfield, Mrs. E. 309 Donald-street, Winnipeg, Canada.
1912. \*Bancroft, Miss Nellie, D.Sc., F.L.S. 260 Normanton-road, Derby.
1898. †Bannerman, W. Bruce, F.S.A. 4 The Waldrons, Croydon.
1910. †Barber, *Miss Mary. 13 Temple Fortune Court, Hendon, N.W.*
1890. \*Barber-Starkey, W. J. S. Aldenham Park, Bridgnorth, Salop.
1861. \*Barbour, George. Bolesworth Castle, Tattenhall, Chester.

Year of  
Election.

1915. §BARCLAY, R. NOTON. 35 Whitworth-street West, Manchester.
1860. \*Barclay, Robert. High Leigh, Hoddesdon, Herts.
1887. \*Barclay, Robert. Sedgley New Hall, Prestwich, Manchester.
1902. †Barcroft, H., D.L. The Glen, Newry, Co. Down.
1902. †BARCROFT, JOSEPH, M.A., B.Sc., F.R.S. King's College, Cambridge.
1911. †Barger, George, M.A., D.Sc., Professor of Chemistry in the Royal Holloway College. Malahide, Englefield Green, Surrey.
1904. §Barker, B. T. P., M.A., Professor of Agricultural Biology in the University of Bristol. Fenswood, Long Ashton, Bristol.
1906. \*Barker, Geoffrey Palgrave. Henstead Hall, Wrentham, Suffolk.
1899. §Barker, John H., M.Inst.C.E. San Simeon, Wolverhampton.
1882. \*Barker, Miss J. M. Sunny Bank, Scalby, Scarborough.
1910. \*Barker, Raymond Inglis Palgrave. Henstead Hall, Wrentham, Suffolk.
1913. §BARLING, Dr. GILBERT. Blythe Court, Norfolk-road, Edgbaston, Birmingham.
1909. †Barlow, Lieut.-Colonel G. N. H. Care of Messrs. Cox & Co., 16 Charing Cross, S.W.
1889. †Barlow, H. W. L., M.A., M.B., F.C.S. The Park Hospital, Hither Green, S.E.
1885. \*BARLOW, WILLIAM, F.R.S., F.G.S. The Red House, Great Stanmore.
1905. \*Barnard, Miss Annie T., M.D., B.Sc. Care of W. Barnard, Esq., 3 New-court, Lincoln's Inn, W.C.
1881. \*Barnard, William, LL.B. 3 New-court, Lincoln's Inn, W.C.
1904. †Barnes, Rev. E. W., M.A., Sc.D., F.R.S. The Temple, E.C.
1907. §Barnes, Professor H. T., Sc.D., F.R.S. McGill University, Montreal, Canada.
1915. §Barnes, Jonathan. 301 Great Clowes-street, Higher Broughton, Manchester.
1909. \*Barnett, Miss Edith A. Holm Leas, Worthing.
1913. §Barnett, Thomas G. The Hollies, Upper Clifton-road, Sutton Coldfield.
1881. †BARR, ARCHIBALD, D.Sc., M.Inst.C.E. (Pres. G, 1912.) Caxton-street, Anniesland, Glasgow.
1902. \*Barr, Mark. Gloucester-mansions, Harrington-gardens, S.W.
1904. †Barrett, Arthur. 6 Mortimer-road, Cambridge.
1872. \*BARRETT, Sir W. F., F.R.S., F.R.S.E., M.R.I.A. 31 Devonshire Place, W.
1874. \*Barrington-Ward, Rev. Mark J., M.A., F.L.S., F.R.G.S. The Rectory, Duloe S.O., Cornwall.
1893. \*BARROW, GEORGE, F.G.S. 202 Brecknock-road, Tufnell Park, N.
1913. †Barrow, Harrison. 57 Wellington-street, Edgbaston, Birmingham.
1913. †Barrow, Louis. 155 Middleton Hall-road, King's Norton.
1913. †Barrow, Walter. 13 Ampton-road, Edgbaston, Birmingham.
1908. †Barry, Gerald H. Wiglin Glebe, Carlow, Ireland.
1884. \*Barstow, Miss Frances A. Garrow Hill, near York.
1890. \*Barstow, J. J. Jackson. The Lodge, Weston-super-Mare.
1890. \*Barstow, Mrs. The Lodge, Weston-super-Mare.
1892. †Bartholomew, John George, F.R.S.E., F.R.G.S. Newington House, Edinburgh.
1858. \*Bartholomew, William Hamond, M.Inst.C.E. Ridgeway House, Cumberland-road, Hyde Park, Leeds.
1909. †Bartleet, Arthur M. 138 Hagley-road, Edgbaston, Birmingham.
1909. †Bartlett, C. Bank of Hamilton-building, Winnipeg, Canada.
1914. †Barton, E. C. City Electric Light Company, Brisbane, Australia.
1893. \*BARTON, EDWIN H., D.Sc., F.R.S., F.R.S.E., Professor of Experimental Physics in University College, Nottingham.



Year of  
Election.

1908. †Barton, Rev. Walter John, M.A., F.R.G.S. Epsom College, Surrey.
1904. \*Bartrum, C. O., B.Sc. 32 Willoughby-road, Hampstead, N.W.
1888. \*BASSETT, A. B., M.A., F.R.S. Fledborough Hall, Holyport, Berkshire.
1891. †Bassett, A. B. Cheverell, Llandaff.
1866. \*BASSETT, HENRY. 26 Belitha-villas, Barnsbury, N.
1911. \*BASSETT, HENRY, jun., D.Sc., Ph.D. University College, Reading.
1889. †BASTABLE, Professor C. F., M.A., F.S.S. (Pres. F, 1894.)  
52 Brighton-road, Rathgar, Co. Dublin.
1912. †Bastian, Staff-Surgeon William, R.N. Chesham Bois, Buckinghamshire.
1883. †BATEMAN, Sir A. E., K.C.M.G. Woodhouse, Wimbledon Park, S.W.
1905. \*Bateman, Mrs. F. D. The Rectory, Minchinhampton.
1907. \*BATEMAN, HARRY. Lake-avenue, Govans, Md., U.S.A.
1914. †Bates, Mrs. Daisy M. 210 Punt-road, Prahran, Victoria.
1884. †BATESON, Professor WILLIAM, M.A., F.R.S. (PRESIDENT, 1914;  
Pres. D, 1904.) The Manor House, Merton, Surrey.
1914. †Bateson, Mrs. The Manor House, Merton, Surrey.
1881. \*BATHER, FRANCIS ARTHUR, M.A., D.Sc., F.R.S., F.G.S. British  
Museum (Natural History), S.W.
1915. †Batho, Cyril, Professor of Applied Mechanics in McGill University,  
Montreal.
1906. §Batty, Mrs. Braithwaite. Ye Gabled House, The Parks, Oxford.
1904. †Baugh, J. H. Agar. 92 Hatton-garden, E.C.
1909. †Bawlf, Nicholas. Assiniboine-avenue, Winnipeg, Canada.
1913. †Bawtree, A. E., F.R.P.S. Lynton, Manor Park-road, Sutton,  
Surrey.
1912. \*Baxter, Miss Evelyn V. Roselea, Kirkton of Largo, Fife.
1912. \*BAYLISS, W. M., M.A., D.Sc., F.R.S. (Pres. I, 1915), Professor of  
General Physiology in University College, London, W.C.
1914. †Bayly, P. G. W. Mines Department, Melbourne.
1876. \*BAYNES, ROBERT E., M.A. Christ Church, Oxford.
1887. \*Baynes, Mrs. R. E. 2 Norham-gardens, Oxford.
1883. \*Bazley, Gardner S. Hatherop Castle, Fairford, Gloucestershire.  
Bazley, Sir Thomas Sebastian, Bart., M.A. Kilmorie, Ilsham-  
drive, Torquay, Devon.
1914. †Beach, Henry, J.P. Clonesslea, Herbert-street, Dulwich Hill,  
Sydney.
1909. \*BEADNELL, H. J. LEWELLYN, F.G.S. Hafod, Llandinam, Mont-  
gomeryshire.
1905. †Beare, Miss Margaret Pierrepont. 10 Regent-terrace, Edinburgh.
1889. §BEARE, Professor T. HUDSON, B.Sc., F.R.S.E., M.Inst.C.E. The  
University, Edinburgh.
1905. †Beare, Mrs. T. Hudson. 10 Regent-terrace, Edinburgh.
1904. †Beasley, H. C. 25A Prince Alfred-road, Wavertree, Liverpool.
1905. †Beattie, Professor J. C., D.Sc., F.R.S.E. South African College,  
Cape Town.
1916. \*Beatty, Richard T., M.A., D.Sc. Physics Laboratory, Queen's  
University, Belfast.
1900. †Beaumont, Professor Roberts, M.I.Mech.E. The University, Leeds.
1885. \*BEAUMONT, W. W., M.Inst.C.E. Outer Temple, 222 Strand, W.C.
1914. †Beaven, E. S. Eastney, Warminster.
1914. †Beaven, Miss M. J. Eastney, Warminster.
1887. \*BECKETT, JOHN HAMPDEN. Corbar Hall, Buxton, Derbyshire.
1904. §Beckit, H. O. Cheney Cottage, Headington, Oxford.
1885. †BEDDARD, FRANK E., M.A., F.R.S., F.Z.S., Prosector of the  
Zoological Society of London, Regent's Park, N.W.

Year of  
Election.

1911. †Beddow, Fred, D.Sc., Ph.D. 2 Pier-mansions, Southsea.  
 1915. §Bedford, Fred, Ph.D., B.Sc. Dovercourt, Heslington-lane, York.  
 1904. \*Bedford, T. G., M.A. 13 Warkworth-street, Cambridge.  
 1891. †Bedlington, Richard. Gadlys House, Aberdare.  
 1878. §BEDSON, P. PHILLIPS, D.Sc., F.C.S. (Local Sec. 1889, 1916),  
 Professor of Chemistry in Armstrong College, Newcastle-upon-  
 Tyne.  
 1901. \*BELLBY, Sir G. T., LL.D., F.R.S. (Pres. B, 1905.) 11 University-  
 gardens, Glasgow.  
 1905. †Beilby, Hubert. 11 University-gardens, Glasgow.  
 1914. §Belas, Philip E., B.A. University College, Cork.  
 1891. \*Belinfante, L. L., M.Sc., Assist. Sec. G.S. Burlington House, W.  
 1916. §Bell, Alfred Ernest. Low Gosforth House, Gosforth.  
 1909. †BELL, C. N. (Local Sec. 1909.) 121 Carlton-street, Winnipeg, Canada.  
 1894. †BELL, F. JEFFREY, M.A., F.Z.S. British Museum (Natural History),  
 S.W.  
 1900. \*Bell, Henry Wilkinson. Beech Cottage, Rawdon, near Leeds.  
 1883. \*Bell, John Henry. 102 Leyland-road, Southport.  
 1915. §Bell, S. B. 116 Cornbrook-street, Old Trafford.  
 1888. \*Bell, Walter George, M.A. Trinity Hall, Cambridge.  
 1914. †Bell, William Reid, M.Inst.C.E. Burnie, Tasmania.  
 1908. \*Bellamy, Frank Arthur, M.A., F.R.A.S. University Observatory,  
 Oxford.  
 1904. †Bellars, A. E. Magdalene College, Cambridge.  
 1913. \*Belliss, John, M.I.M.E. Darlinghurst, Carpenter-road, Edgbaston,  
 Birmingham.  
 1916. §Bennett, Arthur, J.P. Market-gate Chambers, Warrington.  
 1883. \*Bennett, Laurence Henry. The Elms, Paignton, South Devon.  
 1901. †Bennett, Professor Peter. 207 Bath-street, Glasgow.  
 1909. \*Bennett, R. B., K.C. Calgary, Alberta, Canada.  
 1909. †Benson, Miss C. C. Terralta, Port Hope, Ontario, Canada.  
 1903. §Benson, D. E. Queenwood, 12 Irton-road, Southport.  
 1901. \*BENSON, Miss MARGARET J., D.Sc. Royal Holloway College,  
 Englefield Green.  
 1914. †Benson, W. Killara, Sydney, N.S.W.  
 1887. \*Benson, Mrs. W. J. 5 Wellington-court, Knightsbridge, S.W.  
 1898. \*Bent, Mrs. Theodore. 13 Great Cumberland-place, W.  
 1904. †BENTLEY, B. H., M.A., Professor of Botany in the University of  
 Sheffield.  
 1905. \*Bentley, Wilfred. The Dene, Kirkheaton, Huddersfield.  
 1896. \*Bergin, William, M.A., Professor of Natural Philosophy in Uni-  
 versity College, Cork.  
 1894. §BEBKELEY, The Earl of, F.R.S., F.C.S. (Council, 1909-10.)  
 Foxcombe, Boarshill, near Abingdon.  
 1905. \*BERNACCHI, L. C., F.R.G.S. 54 Inverness-terrace, W.  
 1906. \*Bernays, Albert Evan. 3 Priory-road, Kew, Surrey.  
 1898. §Berridge, Miss C. E. 70<sup>A</sup> Redcliffe-square, South Kensington, W.  
 1894. \*BEBBRIDGE, DOUGLAS, M.A., F.C.S. The College, Malvern.  
 1908. \*Berridge, Miss Emily M. Dunton Lodge, The Knoll, Beckenham.  
 1908. \*Berry, Arthur J. 14 Regent-street, Cambridge.  
 1904. §Berry, Professor R. A., F.I.C. West of Scotland Agricultural  
 College, 6 Blythswood-square, Glasgow.  
 1914. §Berry, Professor R. J. A., M.D. The University, Carlton, Mel-  
 bourne.  
 1905. †Bertrand, Captain Alfred. Champel, Geneva.  
 1862. †BESANT, WILLIAM HENRY, M.A., Sc.D., F.R.S. St. John's College,  
 Cambridge.

Year of  
Election.

1916. §Bestow, C. H. Welford House, Upper Clapton, N.E.  
 1913. †Bethune-Baker, G. T. 19 Clarendon-road, Edgbaston, Birmingham.  
 1880. \*BEVAN, Rev. JAMES OLIVER, M.A., F.S.A., F.G.S. Chillenden Rectory, Canterbury.  
 1884. \*Beverley, Michael, M.D. The Shrubbery, Scole, Norfolk.  
 1913. †Bewlay, Hubert. The Lindens, Moseley, Birmingham.  
 1903. †Bickerdike, C. F. 1 Boverney-road, Honor Oak Park, S.E.  
 1870. †Bicketon, Professor A. W. 18 Pembridge-mansions, Moscow-road, W.  
 1888. \*Bidder, George Parker. Savile Club, Piccadilly, W.  
 1911. †BILES, Sir JOHN H., LL.D., D.Sc. (Pres. G, 1911), Professor of Naval Architecture in the University of Glasgow. 10 University-gardens, Glasgow.  
 1898. †Billington, Charles. Heimath, Longport, Staffordshire.  
 1901. \*Bilsland, Sir William, Bart., J.P. 28 Park-circus, Glasgow.  
 1908. \*Bilton, Edward Barnard. Graylands, Wimbledon Common, S.W.  
 1887. \*Bindloss, James B. Elm Bank, Buxton.  
 1881. †BINNIE, Sir ALEXANDER R., M.Inst.C.E., F.G.S. (Pres. G, 1900.) 77 Ladbroke-grove, W.  
 1910. \*Birchough, C., M.A. 8 Severn-road, Sheffield.  
 1887. \*Birley, H. K. Penrhyn, Irlams-o'-th'-Height, Manchester.  
 1915. \*Birley, J. Harold. Cambridge-street, Manchester.  
 1913. †Birtwistle, G. Pembroke College, Cambridge.  
 1904. †Bishop, A. W. Edwinstowe, Chaucer-road, Cambridge.  
 1911. \*Bishop, Major C. F., R.A. *The Castle, Tynemouth, Northumberland.*  
 1906. †Bishop, J. L. Yarrow Lodge, Waldegrave-road, Teddington.  
 1910. †Bisset, John. Thornhill, Inch, Aberdeenshire.  
 1886. \*Bixby, General W. H. 1709 Lanier-place, Washington, U.S.A.  
 1914. \*Black, S. G. Glenormiston, Glenormiston South, Victoria.  
 1909. †Black, W. J., Principal of Manitoba Agricultural College, Winnipeg, Canada.  
 1901. §Black, W. P. M. 136 Wellington-street, Glasgow.  
 1916. \*Blackburn, Miss K. B. Highclere, Queen's-road, Broadstairs.  
 1916. §Blackett, Lieut.-Colonel W. C. Acorn House, Sacriston, near Durham.  
 1903. \*BLACKMAN, F. F., M.A., D.Sc., F.R.S. (Pres. K, 1908.) St. John's College, Cambridge.  
 1908. †BLACKMAN, Professor V. H., M.A., Sc.D., F.R.S. Imperial College of Science and Technology, S.W.  
 1913. §Blackwell, Miss Elsie M., M.Sc. 16 Stanley-avenue, Birkdale, Southport.  
 1913. †Bladen, W. Wells. Stone, Staffordshire.  
 1909. †Blaikie, Leonard, M.A. Civil Service Commission, Burlington-gardens, W.  
 1910. †Blair, Sir R., M.A. London County Council, Spring-gardens, S.W.  
 1902. †Blake, Robert F., F.I.C. Queen's College, Belfast.  
 1914. †Blakemore, Mrs. D. M. Wawona, Cooper-street, Burwood, N.S.W.  
 1914. §Blakemore, G. H. Wawona, Cooper-street, Burwood, N.S.W.  
 1900. \*Blamires, Joseph. Bradley Lodge, Huddersfield.  
 1905. †Blamires, Mrs. Bradley Lodge, Huddersfield.  
 1904. †Blanc, Dr. Gian Alberto. Istituto Fisico, Rome.  
 1915. †Bland, J. Arthur. Thornfield, Baxter-road, Sale.  
 1884. \*Blandy, William Charles, M.A. 1 Friar-street, Reading.  
 1887. \*Bles, Edward J., M.A., D.Sc. Elterholm, Madingley-road, Cambridge.

Year of  
Election.

1884. \*Blish, William G. Niles, Michigan, U.S.A.  
 1913. †Blofield, Rev. S., B.A. Saltley College, Birmingham.  
 1902. †Blount, Bertram, F.I.C. 76 & 78 York-street, Westminster, S.W.  
 1888. †Bloxsom, Martin, B.A., M.Inst.C.E. 4 Lansdowne-road, Crumpsall Green, Manchester.  
 1909. †Blumfeld, Joseph, M.D. 35 Harley-street, W.  
 1887. \*Boddington, Henry, J.P. Pownall, Wilmslow, Manchester.  
 1908. †BOEDDICKER, OTTO, Ph.D. Birr Castle Observatory, Birr, Ireland.  
 1915. †Bohr, N. Physical Laboratory, The University, Manchester.  
 1887. \*Boissevain, Gideon Maria. 4 Tesselschade-straat, Amsterdam.  
 1915. §Bolivar, Mrs. Anna de. 75 Clarendon-road, High-street, Manchester.  
 1911. †Bolland, B. G. C. Department of Agriculture, Cairo, Egypt.  
 1898. §BOLTON, H., M.Sc., F.R.S.E. The Museum, Queen's-road, Bristol.  
 1894. §BOLTON, JOHN, F.R.G.S. 22 Hawes-road, Bromley, Kent.  
 1898. \*BONAR, JAMES, M.A., LL.D. (Pres. F, 1898; Council, 1899-1905.) The Mint, Ottawa, Canada.  
 1909. †Bonar, Thomson, M.D. 114 Via Babuino, Piazza di Spagna, Rome.  
 1912. \*Bond, C. I., F.R.C.S. Springfield-road, Leicester.  
 1914. †Bond, Mrs. C. I. Springfield-road, Leicester.  
 1909. †Bond, J. H. R., M.B. 167 Donald-street, Winnipeg, Canada.  
 1908. †BONE, Professor W. A., D.Sc., F.R.S. (Pres. B, 1915; Council, 1915- ) Imperial College of Science and Technology, S.W.  
 1913. †Bonnar, W., LL.B., Ph.D. Hotel Cecil, Strand, W.C.  
 1871. \*BONNEY, Rev. THOMAS GEORGE, Sc.D., LL.D., F.R.S., F.S.A., F.G.S. (PRESIDENT, 1910; SECRETARY, 1881-85; Pres. C, 1886.) 9 Scroope-terrace, Cambridge.  
 1911. †Bonny, W. Naval Store Office, The Dockyard, Portsmouth.  
 1888. †Boon, William. Coventry.  
 1893. †Boot, Sir Jesse, Bart. Carlyle House, 18 Burns-street, Nottingham.  
 1883. †Booth, James. Hazelhurst, Turton.  
 1910. §Booth, John, M.C.E., B.Sc. The Gables, Berkeley-street, Hawthorn, Victoria, Australia.  
 1883. †Boothroyd, Benjamin. Weston-super-Mare.  
 1912. †Borgmann, Professor J. J., D.Ph., LL.D. Physical Institute, The University, Petrograd.  
 1882. §BORNS, HENRY, Ph.D. 5 Sutton Court-road, Chiswick, W.  
 1901. †Borradaile, L. A., M.A. Selwyn College, Cambridge.  
 1903. \*BOSANQUET, ROBERT C., M.A., Professor of Classical Archæology in the University of Liverpool. Institute of Archæology, 40 Bedford-street, Liverpool.  
 1896. †Bose, Professor J. C., C.I.E., M.A., D.Sc. Calcutta, India.  
 1916. §Boswell, P. G. H., D.Sc., F.G.S. Imperial College of Science and Technology, S.W.  
 1881. §BOTHAMLEY, CHARLES H., M.Sc., F.I.C., F.C.S., Education Secretary, Somerset County Council, Weston-super-Mare.  
 1871. \*BOTTOMLEY, JAMES THOMSON, M.A., LL.D., D.Sc., F.R.S., F.R.S.E., F.C.S. 13 University-gardens, Glasgow.  
 1892. \*BOTTOMLEY, W. B., M.A., Professor of Botany in King's College, Strand, W.C.  
 1909. †Boulenger, C. L., M.A., D.Sc. The University, Birmingham.  
 1905. †BOULENGER, G. A., LL.D., F.R.S. (Pres. D, 1905.) 8 Courtfield-road, S.W.  
 1905. †Boulenger, Mrs. 8 Courtfield-road, S.W.

Year of  
Election.

1903. §BOULTON, W. S., D.Sc., F.G.S. (Pres. C, 1916.) Professor of Geology in the University of Birmingham.
1911. †Bourdillon, R. Balliol College, Oxford.
1883. †BOURNE, Sir A. G., K.C.I.E., D.Sc., F.R.S., F.L.S. Middlepark, Paignton, South Devon.
1914. †Bourne, Lady. Middlepark, Paignton, South Devon.
1893. \*BOURNE, G. C., M.A., D.Sc., F.R.S., F.L.S. (Pres. D, 1910; Council, 1903-09; Local Sec. 1894), Linacre Professor of Comparative Anatomy in the University of Oxford. Savile House, Mansfield-road, Oxford.
1904. \*Bousfield, E. G. P. St. Swithin's, Hendon, N.W.
1913. †Bowater, Sir W. H. Elm House, Arthur-road, Edgbaston, Birmingham.
1913. †Bowater, William. 20 Russell-road, Moseley, Birmingham.
1881. \*BOWER, F. O., Sc.D., F.R.S., F.R.S.E., F.L.S. (Pres. K, 1898, 1914; Council, 1900-06), Regius Professor of Botany in the University of Glasgow.
1898. \*Bowker, Arthur Frank, F.R.G.S., F.G.S. Whitehill, Wrotham, Kent.
1908. §BOWLES, E. Augustus, M.A., F.L.S. Myddelton House, Waltham Cross, Herts.
1898. †BOWLEY, A. L., M.A. (Pres. F, 1906; Council, 1906-11.) North-court-avenue, Reading.
1880. †Bowly, Christopher. Cirencester.
1887. †Bowly, Mrs. Christopher. Cirencester.
1899. \*BOWMAN, HERBERT LISTER, M.A., D.Sc., F.G.S., Professor of Mineralogy in the University of Oxford. Magdalen College, Oxford.
1899. \*Bowman, John Herbert. Greenham Common, Newbury.
1887. §Box, Alfred Marshall. 14 Magrath-avenue, Cambridge.
1901. †Boyd, David T. Rhinsdale, Ballieston, Lanark.
1915. \*Boyd, H. de H. Care of Southern Cotton Oil Company, Trafford Park, Manchester.
1892. †BOYS, CHARLES VERNON, F.R.S. (Pres. A, 1903; Council, 1893-99, 1905-08.) 66 Victoria-street, S.W.
1872. \*BRABROOK, Sir EDWARD, C.B., F.S.A. (Pres. H, 1898; Pres. F, 1903; Council, 1903-10, 1911- ) Langham House, Wallington, Surrey.
1894. \*Braby, Ivon. Helena, Alan-road, Wimbledon, S.W.
1915. †Bradley, F. E., M.A. Bank of England-chambers, Manchester.
1893. †Bradley, F. L. Ingleside, Malvern Wells.
1904. \*Bradley, Gustav. Council Offices, Goole.
1903. \*Bradley, O. Charnock, D.Sc., M.D., F.R.S.E. Royal Veterinary College, Edinburgh.
1892. †Bradshaw, W. Carisbrooke House, The Park, Nottingham.
1863. †BRADY, GEORGE S., M.D., LL.D., F.R.S. Park Hurst, Endcliffe, Sheffield.
1911. †BRAGG, W. H., M.A., F.R.S. (Council, 1913- ), Professor of Physics in the University of London. University College, W.C.
1905. §Brakhan, A. 6 Montague-mansions, Portman-square, W.
1906. †Branfield, Wilfrid. 4 Victoria-villas, Uppertorpe, Sheffield.
1885. \*Bratby, William, J.P. Alton Lodge, Lancaster Park, Harrogate.
1905. †Brausewetter, Miss. Roedean School, near Brighton.
1909. §Bremner, Alexander. 38 New Broad-street, E.C.
1905. †Bremner, R. S. Westminster-chambers, Dale-street, Liverpool.
1905. †Bremner, Stanley. Westminster-chambers, Dale-street, Liverpool.
1913. \*Brenchley, Miss Winifred E., D.Sc., F.L.S. Rothamsted Experimental Station, Harpenden, Herts.

Year of  
Election.

1902. \*Brereton, Cloudesley. 7 Lyndhurst-road, Hampstead, N.W.  
 1909. \*Breton, Miss Adela C. Care of Lloyds Bank, Bath.  
 1908. †Brickwood, Sir John. Branksmere, Southsea.  
 1907. \*Bridge, Henry Hamilton. Fairfield House, Droxford, Hants.  
 1912. †Bridgman, F. J., F.L.S. Zoological Department, University  
 College, W.C.  
 1913. †Brierley, Leonard H. 11 Ampton-road, Edgbaston, Birmingham.  
 1904. \*Briggs, William, M.A., LL.D., F.R.A.S. Burlington House, Cam-  
 bridge.  
 1909. \*Briggs, Mrs. William. Owlbrigg, Cambridge.  
 1908. †Brindley, H. H. 4 Devana-terrace, Cambridge.  
 1893. †Briscoe, Albert E., B.Sc., A.R.C.Sc. The Hoppet, Little Baddow,  
 Chelmsford.  
 1904. †Briscoe, J. J. Bourn Hall, Bourn, Cambridge.  
 1905. §Briscoe, Miss. Bourn Hall, Bourn, Cambridge.  
 1898. †BRISTOL, The Right Rev. G. F. BROWNE, D.D., Lord Bishop of.  
 17 The Avenue, Clifton, Bristol.  
 1879. \*BRITAIN, W. H., J.P., F.R.G.S. Storth Oaks, Sheffield.  
 1905. †Brock, Dr. B. G. P.O. Box 216, Germiston, Transvaal.  
 1907. †Brockington, W. A., M.A. Birstall, Leicester.  
 1915. †Brocklehurst, F. 33 King-street, Manchester.  
 1883. \*Brodie-Hall, Miss W. L. Havenwood, Peaslake, Gomshall, Surrey.  
 1903. †BRODRICK, HAROLD, M.A., F.G.S. (Local Sec. 1903.) 7 Aughton-  
 road, Birkdale, Southport.  
 1913. †Brodrick, Mrs. Harold. 7 Aughton-road, Birkdale, Southport.  
 1904. †Bromwich, T. J. F.A., M.A., F.R.S. 1 Selwyn-gardens, Cambridge.  
 1906. †Brook, Stanley. 18 St. George's-place, York.  
 1911. §Brooke, Colonel Charles K., F.R.G.S. Army and Navy Club, Pall  
 Mall, S.W.  
 1915. †Brooks, Colin. 7 Cedar-street, Southport.  
 1906. \*Brooks, F. T. 31 Tenison-avenue, Cambridge.  
 1883. \*Brough, Mrs. Charles S. 4 Spencer-road, Southsea.  
 1886. †Brough, Joseph, LL.D., Professor of Logic and Philosophy in Uni-  
 versity College, Aberystwyth.  
 1913. †Brown, Professor A. J., M.Sc., F.R.S. West Heath House, North-  
 field, Birmingham.  
 1905. †Brown, A. R. Trinity College, Cambridge.  
 1863. \*BROWN, ALEXANDER CRUM, M.D., LL.D., F.R.S., F.R.S.E.,  
 V.P.C.S. (Pres. B, 1874; Local Sec. 1871.) 8 Belgrave-  
 crescent, Edinburgh.  
 1883. †Brown, Mrs. Ellen F. Campbell. 27 Abercromby-square, Liver-  
 pool.  
 1905. §Brown, Professor Ernest William, M.A., D.Sc., F.R.S. Yale Uni-  
 versity, New Haven, Conn., U.S.A.  
 1914. †Brown, F. G., B.A., B.Sc. Naval College, North Geelong, Victoria,  
 Australia.  
 1903. †Brown, F. W. 6 Rawlinson-road, Southport.  
 1914. †Brown, Rev. George, D.D. Kinawanua, Gordon, N.S.W.  
 1870. §BROWN, HORACE T., LL.D., F.R.S., F.G.S. (Pres. B, 1899; Council,  
 1904-11.) 52 Nevern-square, S.W.  
 1881. \*Brown, John, M.D. Liesbreek-road, Mowbray, Cape of Good  
 Hope.  
 1895. \*Brown, John Charles. 39 Burlington-road, Sherwood, Notting-  
 ham.  
 1882. \*Brown, Mrs. Mary. Liesbreek-road, Mowbray, Cape of Good Hope.  
 1901. †Brown, Professor R. N. Rudmose, D.Sc. The University, Sheffield.  
 1908. §BROWN, SIDNEY G., F.R.S. 52 Kensington Park-road, W.

Year of  
Election.

1905. §Brown, Mrs. Sidney G. 52 Kensington Park-road, W.  
 1910. \*Brown, Sidney J. R. 52 Kensington Park-road, W.  
 1912. †Brown, T. Graham. The University, Liverpool.  
 1884. †Brown, W. G. University of Missouri, Columbia, Missouri, U.S.A.  
 1908. †Brown, William, B.Sc. 48 Dartmouth-square, Dublin.  
 1912. †Brown, Dr. William. *Thornfield, Horley, Surrey.*  
 1906. †Browne, Charles E., B.Sc. Christ's Hospital, West Horsham.  
 1900. \*BROWNE, FRANK BALFOUR, M.A., F.R.S.E., F.Z.S. 26 Barton-road, Cambridge.  
 1908. †Browne, Rev. Henry, M.A., Professor of Greek in University College, Dublin.  
 1895. \*Browne, H. T. Doughty. 6 Kensington House, Kensington-court, W.  
 1879. †BROWNE, Sir J. CRICHTON, M.D., LL.D., F.R.S., F.R.S.E. 45 Hans-place, S.W.  
 1905. \*Browne, James Stark, F.R.A.S. Hanmer House, Mill Hill Park, W.  
 1883. †Browning, Oscar, M.A. King's College, Cambridge.  
 1912. §BROWNING, T. B., M.A. 18 Bury-street, Bloomsbury, W.C.  
 1905. §BRUCE, Surgeon-General Sir DAVID, A.M.S., C.B., F.R.S. (Pres. I, 1905.) Royal Army Medical College, Grosvenor-road, S.W.  
 1905. †Bruce, Lady. 3P Artillery-mansions, Victoria-street, S.W.  
 1893. †BRUCE, WILLIAM S., LL.D., F.R.S.E. Scottish Oceanographical Laboratory, Surgeons' Hall, Edinburgh.  
 1900. \*Brumm, Charles. Edendale, Whalley-road, Whalley Range, Manchester.  
 1896. \*Brunner, Right Hon. Sir J. T., Bart. Silverlands, Chertsey.  
 1897. \*Brush, Charles F. Cleveland, Ohio, U.S.A.  
 1886. \*BRYAN, G. H., D.Sc., F.R.S., Professor of Mathematics in University College, Bangor.  
 1894. †Bryan, Mrs. R. P. Plas Gwyn, Bangor.  
 1884. \*BRYCE, Rev. Professor GEORGE, D.D., LL.D. Kilmadock, Winnipeg, Canada.  
 1909. †Bryce, Thomas H., M.D., Professor of Anatomy in the University of Glasgow. 2 The College, Glasgow.  
 1902. \*Bubb, Miss E. Maude. Ullenwood, near Cheltenham.  
 1890. §Bubb, Henry. Ullenwood, near Cheltenham.  
 1902. \*BUCHANAN, Miss FLORENCE, D.Sc. University Museum, Oxford.  
 1905. †Buchanan, Hon. Sir John. Clareinch, Claremont, Cape Town.  
 1909. †Buchanan, W. W. P.O. Box 1658, Winnipeg, Canada.  
 1914. †Buck, E. J. Menzies' Hotel, Melbourne.  
 1913. †Buckland, H. T. 21 Yateley-road, Edgbaston, Birmingham.  
 1884. \*Buckmaster, Charles Alexander, M.A., F.C.S. 16 Heathfield-road, Mill Hill Park, W.  
 1904. †Buckwell, J. C. North Gate House, Pavilion, Brighton.  
 1893. §BULLEID, ARTHUR, F.S.A. Dymboro, Midsomer Norton, Bath.  
 1913. \*Bulleid, C. H. University College, Nottingham.  
 1913. \*Buller, A. H. Reginald, Professor of Botany in the University of Manitoba, Winnipeg.  
 1916. §Bulman, H. F. Moss Garth, Portinscale, Keswick.  
 1909. †BULYEA, The Hon. G. H. V. Edmonton, Alberta, Canada.  
 1914. †Bunday, Miss E. M. Molesworth-street, North Adelaide, South Australia.  
 1916. §Burbidge, Sir Richard, Bart. 51 Hans-mansions, Chelsea, S.W.  
 1905. †Burbury, Mrs. A. A. 15 Melbury-road, W.  
 1905. †Burbury, Miss A. D. 15 Melbury-road, W.  
 1881. †Burdett-Coutts, William Lehmann, M.P. 1 Stratton-street, Piccadilly, W.

Year of  
Election.

1905. †BURDON, E. R., M.A. Ikenhilde, Royston, Herts.  
 1913. †Burfield, Stanley Thomas. Zoology Department, The University, Liverpool.  
 1913. \*Burgess, J. Howard. Shide, Newport, Isle of Wight.  
 1894. †BURKE, JOHN B. B. Trinity College, Cambridge.  
 1884. \*Burland, Lieut.-Colonel Jeffrey H. 342 Sherbrooke-street West, Montreal, Canada.  
 1915. §Burlin, Adolph L., Ph.D. 56 Broad-street, Pendleton.  
 1899. †Burls, H. T., F.G.S. 2 Verulam-buildings, Gray's Inn, W.C.  
 1904. †Burn, R. H. 21 Stanley-crescent, Notting-hill, W.  
 1909. †Burns, F. D. 203 Morley-avenue, Winnipeg, Canada.  
 1914. \*Burns, Colonel James. Gowan Brae, Parramatta, N.S.W.  
 1908. †Burnside, W. Snow, D.Sc., Professor of Mathematics in the University of Dublin. 35 Raglan-road, Dublin.  
 1909. †Burrows, Theodore Arthur. 187 Kennedy-street, Winnipeg, Canada.  
 1910. †Burt, Cyril. L.C.C. Education Offices, Victoria Embankment, W.C.  
 1909. †Burton, E. F. 129 Howland-avenue, Toronto, Canada.  
 1911. †Burton, J. H. Agriculture Office, Weston-super-Mare.  
 1892. †Burton-Brown, Colonel A., R.A., F.G.S. Royal Societies Club, St. James's-street, S.W.  
 1904. †Burt, Arthur H., D.Sc. 4 South View, Holgate, York.  
 1906. †Burt, Philip. Swarthmore, St. George's-place, York.  
 1909. †Burwash, E. M., M.A. New Westminster, British Columbia, Canada.  
 1887. \*Bury, Henry. Mayfield House, Farnham, Surrey.  
 1899. †Bush, Anthony. 43 Portland-road, Nottingham.  
 1895. †Bushe, Colonel C. K., F.G.S. 19 Cromwell-road, S.W.  
 1908. \*Bushell, W. F. Rossall School, Fleetwood.  
 1910. †Butcher, Miss. 25 Earl's Court-square, S.W.  
 1884. \*Butcher, William Deane, M.R.C.S.Eng. Holyrood, 9 Cleveland-road, Ealing, W.  
 1916. §Butler, George Grey, J.P. Ewart Park, Wooler, Northumberland.  
 1913. \*Butler, W. Waters. Southfield, Norfolk-road, Edgbaston, Birmingham.  
 1915. \*Butterworth, Charles F. Waterloo, Poynton, Cheshire.  
 1884. \*Butterworth, W. Carisbrooke, Rhiw-road, Colwyn Bay, North Wales.  
 1899. †Byles, Arthur R. 'Bradford Observer,' Bradford, Yorkshire.  
 1913. §Cadbury, Edward. Westholme, Selly Oak, Birmingham.  
 1913. †Cadbury, W. A. Wast Hills, King's Norton.  
 1892. †Cadell, H. M., B.Sc., F.R.S.E. Grange, Linlithgow.  
 1913. †Cadman, John, C.M.G., D.Sc., Professor of Mining in the University of Birmingham. 61 Wellington-road, Edgbaston, Birmingham.  
 1913. †Cadman, Lieutenant W. H., B.Sc. Bryncliff Lodge, Little Orme, Llandudno.  
 1913. †Cahill, J. R. 49 Hanover Gate-mansions, Regent's Park, N.W.  
 1912. §Caine, Nathaniel. Spital, Cheshire.  
 1901. †Caldwell, Hugh. Blackwood, Newport, Monmouthshire.  
 1907. †Caldwell, K. S. St. Bartholomew's Hospital, E.C.  
 1897. †CALLENDAR, HUGH L., M.A., LL.D., F.R.S. (Pres. A, 1912; Council, 1900-06), Professor of Physics in the Imperial College of Science and Technology, S.W.  
 1911. †Calman, W. T., D.Sc. British Museum (Natural History), Cromwell-road, S.W.



Year of  
Election.

1916. §Calvert, Joseph. Park View, Middlesbrough.  
 1914. †Cambage, R. H., F.L.S. Department of Mines, Sydney, N.S.W.  
 1911. †Cameron, Alexander T. Physiological Department, University of  
 Manitoba, Winnipeg.  
 1857. †CAMERON, Sir CHARLES A., C.B., M.D. 51 Pembroke-road, Dublin.  
 1909. †Cameron, D. C. 65 Roslyn-road, Winnipeg, Canada.  
 1896. §Cameron, Irving H., LL.D., Professor of Surgery in the University  
 of Toronto. 307 Sherbourne-street, Toronto, Canada.  
 1909. †Cameron, Hon. Mr. Justice J. D. Judges' Chambers, Winnipeg,  
 Canada.  
 1901. §Campbell, Archibald. Park Lodge, Albert-drive, Pollokshields,  
 Glasgow.  
 1897. †Campbell, Colonel J. C. L. Achalader, Blairgowrie, N.B.  
 1909. \*Campbell, R. J. Holdenhurst, Hendon-avenue, Church End,  
 Finchley, N.  
 1909. †Campbell, Mrs. R. J. Holdenhurst, Hendon-avenue, Church  
 End, Finchley, N.  
 1902. †Campbell, Robert. 21 Great Victoria-street, Belfast.  
 1912. †Campbell, Dr. Robert. Geological Department, The University,  
 Edinburgh.  
 1890. †CANNAN, Professor EDWIN, M.A., LL.D., F.S.S. (Pres. F, 1902.)  
 11 Chadlington-road, Oxford.  
 1905. †Cannan, Gilbert. *King's College, Cambridge.*  
 1897. §Cannon, Herbert. Alconbury, Bexley Heath, Kent.  
 1904. †Capell, Rev. G. M. Passenham Rectory, Stony Stratford.  
 1911. †Capon, R. S. 49A Rodney-street, Liverpool.  
 1905. \*Caporn, Dr. A. W. Muizenberg, South Africa.  
 1894. †CAPPER, D. S., M.A., Professor of Mechanical Engineering in King's  
 College, W.C.  
 1887. †CAPSTICK, J. W. Trinity College, Cambridge.  
 1896. \*Carden, H. *Vandeleur. Fir Lodge, Broomfield, Chelmsford.*  
 1913. †Carlier, E. Wace, M.Sc., M.D., F.R.S.E., Professor of Physiology  
 in the University of Birmingham. The University, Edmund-  
 street, Birmingham.  
 1914. †Carne, J. E. Mines Department, Sydney, N.S.W.  
 1913. §Carpenter, Charles. 157 Victoria-street, S.W.  
 1913. \*Carpenter, G. D. H., M.B. 19 Bardwell-road, Oxford.  
 1902. †Carpenter, G. H., B.Sc., Professor of Zoology in the Royal College  
 of Science, Dublin.  
 1906. \*Carpenter, H. C. H. 30 Murray-road, Wimbledon.  
 1905. †Carpmael, Edward, F.R.A.S., M.Inst.C.E. The Ivies, 118 St.  
 Julian's Farm-road, West Norwood, S.E.  
 1912. \*Carr, H. Wildon, D.Litt. 107 Church-street, Chelsea, S.W.  
 1910. †Carr, Henry F. Broadparks, Pinhoe, near Exeter.  
 1893. †CARR, J. WESLEY, M.A., F.L.S., F.G.S., Professor of Biology in  
 University College, Nottingham.  
 1906. \*Carr, Richard E. Sylvan Mount, Sylvan-road, Upper Norwood, S.E.  
 1889. †Carr-Ellison, John Ralph. Hedgeley, Alnwick.  
 1911. †Carruthers, R. G., F.G.S. Geological Survey Office, 33 George-  
 square, Edinburgh.  
 1867. †CARRUTHERS, WILLIAM, F.R.S., F.L.S., F.G.S. (Pres. D, 1886.)  
 44 Central-hill, Norwood, S.E.  
 1886. †CARSLAKE, J. BARNHAM (Local Sec. 1886.) 30 Westfield-road,  
 Birmingham.  
 1899. †CARSLAW, H. S., D.Sc., Professor of Mathematics in the University  
 of Sydney, N.S.W.  
 1914. §Carson, Rev. James. The Manse, Cowper, N.S.W.

Year of  
Election.

1900. \*CARTER, W. LOWER, M.A., F.G.S. 9 Belmont-road, Watford.
1896. †Cartwright, Miss Edith G. 21 York Street-chambers, Bryanston-square, W.
1878. \*Cartwright, Ernest H., M.A., M.D. Myskyns, Ticehurst, Sussex.
1870. §Cartwright, Joshua, M.Inst.C.E., F.S.I. 21 Parsons-lane, Bury, Lancashire.
1862. †Carulla, F. J. R. 84 Rosehill-street, Derby.
1894. †Carus, Dr. Paul. La Salle, Illinois, U.S.A.
1913. §Carus-Wilson, Cecil, F.R.S.E., F.G.S. Altmore, Waldegrave-park, Strawberry Hill, Twickenham.
1901. †Carver, Thomas A. B., D.Sc., Assoc.M.Inst.C.E. 9 Springfield-road, Dalmarnock, Glasgow.
1899. \*Case, J. Monckton. Department of Lands (Water Branch), Victoria, British Columbia.
1897. \*Case, Willard E. Auburn, New York, U.S.A.
1908. \*Cave, Charles J. P., M.A. Ditcham Park, Petersfield.
1910. †Chadburn, A. W. Brincliffe Rise, Sheffield.
1905. \*Challenor, Bromley, M.A. The Firs, Abingdon.
1905. \*Challenor, Miss E. M. The Firs, Abingdon.
1910. †Chalmers, Stephen D. 25 Cornwall-road, Stroud Green, N.
1913. †Chalmers, Mrs. S. D. 25 Cornwall-road, Stroud Green, N.
1913. †CHAMBERLAIN, NEVILLE. Westbourne, Edgbaston, Birmingham.
1914. §Chamberlin, Dr. R. T. Geological Department, University of Chicago, U.S.A.
1913. †Chambers, Miss Beatrice Anne. Glyn-y-mêl, Fishguard.
1901. §Chamen, W. A. South Wales Electrical Power Distribution Company, Royal-chambers, Queen-street, Cardiff.
1905. †Champion, G. A. Haraldene, Chelmsford-road, Durban, Natal.
1881. \*Champney, John E. 27 Hans-place, S.W.
1908. †Chance, Sir Arthur, M.D. 90 Merrion-square, Dublin.
1916. \*Chauc, C. F., M.A. 12 Arthur-road, Edgbaston, Birmingham.
1888. †Chandler, S. Whitty, B.A. St. George's, Cecil-road, Boscombe.
1907. \*Chapman, Alfred Chaston, F.I.C. 8 Duke-street, Aldgate, E.C.
1902. \*Chapman, D. L., M.A., F.R.S. Jesus College, Oxford.
1914. §Chapman, H. G., M.D. Department of Physiology, The University, Sydney, N.S.W.
1910. †Chapman, J. E. Kinross.
1899. †CHAPMAN, Professor SYDNEY JOHN, M.A., M.Com. (Pres. F, 1909.) Burnage Lodge, Levenshulme, Manchester.
1912. \*Chapman, Sydney, D.Sc., B.A., F.R.A.S. Trinity College, Cambridge.
1910. †Chappell, Cyril. 73 Neill-road, Sheffield.
1916. §Charlesworth, Dr. J. K. Queen's University, Belfast.
1905. †Chassigneux, E. 12 Tavistock-road, Westbourne-park, W.
1904. \*Chattaway, F. D., M.A., D.Sc., Ph.D., F.R.S. 151 Woodstock-road, Oxford.
1886. \*CHATTOCK, A. P., D.Sc. Heathfield Cottage, Crowcombe, Somerset.
1904. \*Chaundy, Theodore William, M.A. Christ Church, Oxford.
1913. †Cheesman, Miss Gertrude Mary. The Crescent, Selby.
1900. \*Cheesman, W. Norwood, J.P., F.L.S. The Crescent, Selby.
1874. \*Chermiside, Lieut.-General Sir Herbert, R.E., G.C.M.G., C.B. Newstead Abbey, Nottingham.
1908. †Cherry, Right Hon. Lord Justice. 92 St. Stephen's Green, Dublin.
1910. †Chesney, Miss Lilian M., M.B. 381 Glossop-road, Sheffield.
1879. \*Chesterman, W. Belmayne, Sheffield.

Year of  
Election.

1911. \*Chick, Miss H., D.Sc. Chestergate, Park-hill, Ealing, W.  
 1908. †Chill, Edwin, M.D. Westleigh, Mattock-road, Ealing, W.  
 1883. †Chinery, Edward F., J.P. Lymington.  
 1894. †CHISHOLM, G. G., M.A., B.Sc., F.R.G.S. (Pres. E, 1907.) 12  
 Hallhead-road, Edinburgh.  
 1899. §Chitty, Edward. Sonnenberg, Castle-avenue, Dover.  
 1899. †Chitty, Mrs. Edward. Sonnenberg, Castle-avenue, Dover.  
 1904. §Chivers, John, J.P. Wychfield, Cambridge.  
 1882. †Chorley, George. Midhurst, Sussex.  
 1909. †Chow, H. H., M.D. 263 Broadway, Winnipeg, Canada.  
 1893. \*CHREE, CHARLES, Sc.D., F.R.S. Kew Observatory, Richmond,  
 Surrey.  
 1913. §Christie, Dr. M. G. Post Office House, Leeds.  
 1900. \*Christie, R. J. Duke-street, Toronto, Canada.  
 1875. \*Christopher, George, F.C.S. Thorncroft, Chislehurst.  
 1903. †Clapham, J. H., M.A. King's College, Cambridge.  
 1901. §Clark, Archibald B., M.A., Professor of Political Economy in the  
 University of Manitoba, Winnipeg, Canada.  
 1905. \*Clark, Cumberland, F.R.G.S. 22 Kensington Park-gardens, W.  
 1907. \*Clark, Mrs. Cumberland. 22 Kensington Park-gardens, W.  
 1877. \*Clark, F. J., J.P., F.L.S. Netherleigh, Street, Somerset.  
 1902. †Clark, G. M. South African Museum, Cape Town.  
 1881. \*Clark, J. Edmund, B.A., B.Sc. Asgarth, Riddlesdown-road,  
 Purley, Surrey.  
 1909. †Clark, J. M., M.A., K.C. The Kent Building, 156 Yonge-street,  
 Toronto, Canada.  
 1908. †Clark, James, B.Sc., Ph.D. Newtown School, Waterford, Ireland.  
 1908. †Clark, John R. W. Brothock Bank House, Arbroath, Scotland.  
 1901. \*Clark, Robert M., B.Sc., F.L.S. 27 Albyn-place, Aberdeen.  
 1907. \*Clarke, E. Russell. 11 King's Bench-walk, Temple, E.C.  
 1902. \*CLARKE, Miss LILLIAN J., B.Sc., F.L.S. Chartfield Cottage, Brasted  
 Chart, Kent.  
 1889. \*CLAYDEN, A. W., M.A., F.G.S. 5 The Crescent, Mount Radford,  
 Exeter.  
 1909. §Cleeves, Frederick, F.Z.S. 120 Fenchurch-street, E.C.  
 1909. †Cleeves, W. B. Public Works Department, Government-buildings,  
 Pretoria.  
 1914. §Clegg, Mrs. Florence M. Burong, Sussex-street, Ballarat, Victoria,  
 Australia.  
 1915. †Clegg, John Gray. 22 St. John-street, Manchester.  
 1861. †CLELAND, JOHN, M.D., D.Sc., F.R.S. Drumclog, Crewkerne,  
 Somerset.  
 1905. §Cleland, Mrs. Drumclog, Crewkerne, Somerset.  
 1905. §Cleland, Lieutenant J. R. Drumclog, Crewkerne, Somerset.  
 1902. †Clements, Olaf P. Tana, St. Bernard's-road, Olton, Warwick.  
 1904. §CLERK, DUGALD, D.Sc., F.R.S., M.Inst.C.E. (Pres. G, 1908;  
 Council, 1912- ) 57 and 58 Lincoln's Inn Fields, W.C.  
 1909. †Cleve, Miss E. K. P. 74 Kensington Gardens-square, W.  
 1861. \*CLIFTON, R. BELLAMY, M.A., F.R.S., F.R.A.S. 3 Bardwell-road,  
 Banbury-road, Oxford.  
 1906. §CLOSE, Colonel C. F., R.E., C.M.G., F.R.G.S. (Pres. E, 1911;  
 Council, 1908-12.) Ordnance Survey Office, Southampton.  
 1914. †Close, J. Campbell. 217 Clarence-street, Sydney, N.S.W.  
 1883. \*CLOWES, Professor FRANK, D.Sc., F.C.S. (Local Sec. 1893.)  
 The Grange, College-road, Dulwich, S.E.  
 1914. †Clowes, Mrs. The Grange, College-road, Dulwich, S.E.  
 1912. §Clubb, Joseph A., D.Sc. Free Public Museum, Liverpool.

Year of  
Election.

1891. \*Coates, Henry, F.R.S.E. Corarder, Perth.  
 1911. §Cobbold, E. S., F.G.S. Church Stretton, Shropshire.  
 1908. \*Cochrane, Miss Constance. The Downs, St. Neots.  
 1908. †Cochrane, Robert, I.S.O., LL.D., F.S.A. 17 Highfield-road, Dublin.  
 1901. †Cockburn, Sir John, K.C.M.G., M.D. 10 Gatestone-road, Upper Norwood, S.E.  
 1883. †Cockshott, J. J. 24 Queen's-road, Southport.  
 1913. †Codd, J. Alfred. 7 Tettenhall-road, Wolverhampton.  
 1861. \*Coe, Rev. Charles C., F.R.G.S. Whinsbridge, Grosvenor-road, Bournemouth.  
 1898. †Coffey, George. 5 Harcourt-terrace, Dublin.  
 1896. \*Coghill, Percy de G. Sunnyside House, Prince's Park, Liverpool.  
 1914. †Coghill, Mrs. Una. Monomeath-avenue, Canterbury, Victoria.  
 1887. †Cohen, Professor J. B., F.R.S. The University, Leeds.  
 1901. †Cohen, R. Waley, B.A. 11 Sussex-square, W.  
 1906. \*COKER, ERNEST GEORGE, M.A., D.Sc., F.R.S., M.Inst.C.E. (Pres. G, 1914) Professor of Civil and Mechanical Engineering, University College, Gower-street, W.C.  
 1914. †Coker, Mrs. 3 Farnley-road, Chingford, Essex.  
 1895. \*Colby, William Henry. 80 Coldharbour-road, Redland, Bristol.  
 1913. §COLE, Professor F. J. University College, Reading.  
 1893. §COLE, GRENVILLE A. J., F.G.S. (Pres. C, 1915), Professor of Geology in the Royal College of Science, Dublin.  
 1903. †Cole, Otto B. 551 Boylston-street, Boston, U.S.A.  
 1910. §Cole, Thomas Skelton. Westbury, Endcliffe-crescent, Sheffield.  
 1897. §COLEMAN, Professor A. P., M.A., Ph.D., F.R.S. (Pres. C, 1910.) 476 Huron-street, Toronto, Canada.  
 1899. †Collard, George. The Gables, Canterbury.  
 1892. †Collet, Miss Clara E. 7 Coleridge-road, N.  
 1912. †Collett, J. M., J.P. Kimsbury House, Gloucester.  
 1887. †COLLIE, J. NORMAN, Ph.D., F.R.S., Professor of Organic Chemistry in the University of London. 16 Campden-grove, W.  
 1913. †Collinge, Walter E., M.Sc. The Gatty Marine Laboratory, The University, St. Andrews, N.B.  
 1916. §Collingwood, Arthur B. Lilburn Tower, Alnwick, Northumberland.  
 1861. \*Collingwood, J. Frederick, F.G.S. 8 Oakley-road, Canonbury, N.  
 1910. \*Collins, S. Hoare. 9 Cavendish-place, Newcastle-on-Tyne.  
 1902. †Collins, T. R. Belfast Royal Academy, Belfast.  
 1917. §Collis, E. L., M.B. Factory Department, Home Office, S.W.  
 1914. †Collum, Mrs. Anna Maria. 18 Northbrook-road, Leeson Park, Dublin.  
 1892. †Colman, Dr. Harold G. 1 Arundel-street, Strand, W.C.  
 1910. \*Colver, Robert, jun. Graham-road, Ranmoor, Sheffield.  
 1905. \*Combs, Rev. Cyril W., M.A. Elverton, Castle-road, Newport, Isle of Wight.  
 1910. \*Compton, Robert Harold, B.A. Gonville and Caius College, Cambridge.  
 1912. §Conner, Dr. William. The Priory, Waterlooville, Hants.  
 1902. †Conway, A. W. 100 Leinster-road, Rathmines, Dublin.  
 1903. †Conway, R. Seymour, Litt.D., Professor of Latin in Owens College, Manchester.  
 1898. †Cook, Ernest H., D.Sc. 27 Berkeley-square, Clifton, Bristol.  
 1913. §Cook, Gilbert, M.Sc., Assoc.M.Inst.C.E. Engineering Department, The University, Manchester.  
 1876. \*COOKE, CONRAD W. The Pines, Langland-gardens, Hampstead, N. W.

Year of  
Election.

1911. †Cooke, J. H. 101 Victoria-road North, Southsea.  
 1914. †Cooke, William Ternant, D.Sc. Fourth-avenue, East Adelaide,  
 South Australia.  
 1915. †Cookson, A. Ellis. 14 Hargreaves-buildings, Liverpool.  
 1916. \*Cookson, Clive. Nether Warden, Hexham.  
 1914. †Cookson, Miss Isabel C. 154 Power-street, Hawthorn, Melbourne.  
 1888. †Cooley, George Parkin. Constitutional Club, Nottingham.  
 1899. \*Coomaraswamy, A. K., D.Sc., F.L.S., F.G.S. Broad Campden,  
 Gloucestershire.  
 1903. †Cooper, Miss A. J. 22 St. John-street, Oxford.  
 1901. \*Cooper, C. Forster, B.A. Trinity College, Cambridge.  
 1911. †Cooper, W. E. Henwick Lodge, Worcester.  
 1912. †Cooper, W. F. The Laboratory, Rickmansworth-road, Watford.  
 1907. †Cooper, William. Education Offices, Becket-street, Derby.  
 1904. \*COPEMAN, S. MONCKTON, M.D., F.R.S. Local Government Board,  
 Whitehall, S.W.  
 1909. †Copland, Mrs. A. Johns. Gleniffer, 50 Woodberry Down, N.  
 1904. \*Copland, Miss Louisa. 10 Wynnstay-gardens, Kensington, W.  
 1909. †Corbett, W. A. 207 Bank of Nova Scotia-building, Winnipeg,  
 Canada.  
 1894. †Corcoran, Miss Jessie R. Rotherfield Cottage, Bexhill-on-Sea.  
 1916. †Corder, Percy. 1 Collingwood-terrace, Newcastle-on-Tyne.  
 1915. †Corker, James S. Care of Macintosh & Co., Ltd., Cambridge-  
 street, Manchester.  
 1901. \*Cormack, J. D., D.Sc., Professor of Civil Engineering and Mechanics  
 in the University of Glasgow.  
 1893. \*Corner, Samuel, B.A., B.Sc. Abbotsford House, Waverley-  
 street, Nottingham.  
 1889. †CORNISH, VAUGHAN, D.Sc., F.R.G.S. Woodville, Camberley.  
 1884. \*Cornwallis, F. S. W., F.L.S. Linton Park, Maidstone.  
 1900. †CORTIE, Rev. A. L., S.J., F.R.A.S. Stonyhurst College, Blackburn.  
 1905. †Cory, Professor G. E., M.A. Rhodes University College, Grahams-  
 town, Cape Colony.  
 1909. \*Cossar, G. C., M.A., F.G.S. Southview, Murrayfield, Edinburgh.  
 1910. †Cossar, James. 23 Coltbridge-terrace, Murrayfield, Midlothian.  
 1911. †Cossey, Miss, M.A. High School for Girls, Kent-road, Southsea.  
 1908. \*Costello, John Francis, B.A. The Rectory, Ballymackey, Nenagh,  
 Ireland.  
 1874. \*COTTERILL, J. H., M.A., F.R.S. Hillcrest, Parkstone, Dorset.  
 1908. †Cotton, Alderman W. F., D.L., J.P., M.P. Hollywood, Co. Dublin.  
 1908. †Courtenay, Colonel Arthur H., C.B., D.L. United Service Club,  
 Dublin.  
 1896. †COURTNEY, Right Hon. Lord. (Pres. F, 1896.) 15 Cheyne-walk,  
 Chelsea, S.W.  
 1911. †Couzens, Sir G. E., K.L.H. Glenthorne, Kingston-crescent, Ports-  
 mouth.  
 1908. †Cowan, P. C., B.Sc., M.Inst.C.E. 33 Ailesbury-road, Dublin.  
 1872. \*Cowan, Thomas William, F.L.S., F.G.S. Upcott House, Taunton,  
 Somersetshire.  
 1903. †Coward, H. Knowle Board School, Bristol.  
 1915. †Coward, H. F. 216 Plymouth-grove, Manchester.  
 1900. †Cowburn, Henry. Dingle Head, Leigh, Lancashire.  
 1914. †Cowburn, Mrs. Dingle Head, Leigh, Lancashire.  
 1895. \*COWELL, PHILIP H., M.A., D.Sc., F.R.S. 62 Shooters Hill-road,  
 Blackheath, S.E.  
 1899. †Cowper-Coles, Sherard. 1 and 2 Old Pye-street, Westminster,  
 S.W.

Year of  
Election.

1913. †Cox, A. Hubert. King's College, Strand, W.C.  
 1909. †Cox, F. J. C. Anderson-avenue, Winnipeg, Canada.  
 1905. †Cox, W. H. Royal Observatory, Cape Town.  
 1912. †Craig, D. D., M.A., B.Sc., M.B. The University, St. Andrews, N.B.  
 1911. §Craig, J. I. Homelands, Park-avenue, Worthing.  
 1903. †Craig, James, M.D. 18 Merrion-square North, Dublin.  
 1834. §CRAIGIE, Major P. G., C.B., F.S.S. (Pres. F, 1900; Council, 1908-15.) Bronté House, Lympstone, Devon.  
 1906. †Craik, Sir Henry, K.C.B., LL.D., M.P. 5A Dean's-yard, Westminster, S.W.  
 1908. \*CRAMER, W., Ph.D., D.Sc. Imperial Cancer Research Fund, Queen-square, Bloomsbury, W.C.  
 1906. †Cramp, William, D.Sc. 33 Brazennose-street, Manchester.  
 1905. \*CRANSWICK, W. F. P.O. Box 65, Bulawayo, Rhodesia.  
 1906. †CRAVEN, HENRY. (Local Sec. 1906.) Greenbank, West Lawn, Sunderland.  
 1905. †Crawford, Mrs. A. M. Marchmont, Rosebank, near Cape Town.  
 1905. †Crawford, Professor Lawrence, M.A., D.Sc., F.R.S.E. South African College, Cape Town.  
 1910. \*Crawford, O. G. S. Tan House, Donnington, Berkshire.  
 1871. \*Crawford, William Caldwell, M.A. 1 Lockharton-gardens, Colinton-road, Edinburgh.  
 1905. †Crawford, W. C., jun. 1 Lockharton-gardens, Colinton-road, Edinburgh.  
 1890. §Crawshaw, Charles B. Rufford Lodge, Dewsbury.  
 1883. \*Crawshaw, Edward, F.R.G.S. 25 Tollington-park, N.  
 1885. §CREAK, Captain E. W., C.B., R.N., F.R.S. (Pres. E, 1903; Council, 1896-1903.) 9 Hervey-road, Blackheath, S.E.  
 1876. \*Crewdson, Rev. Canon George. Whitstead, Barton-road, Cambridge.  
 1887. \*Crewdson, Theodore. Spurs, Styall, Handforth, Manchester.  
 1911. †Crick, George C., F.G.S. British Museum (Natural History), S.W.  
 1904. †Crilly, David. 7 Well-street, Paisley.  
 1880. \*Crisp, Sir Frank, Bart., B.A., LL.B., F.L.S., F.G.S. 5 Lansdowne-road, Notting Hill, W.  
 1908. †Crocker, J. Meadmore. Albion House, Bingley, Yorkshire.  
 1905. §Croft, Miss Mary. Quedley, Shottermill.  
 1890. \*Croft, W. B., M.A. 9 College-street, Winchester, Hampshire.  
 1913. §Crombie, J. E., LL.D. Parkhill House, Dyce, Aberdeenshire.  
 1903. \*Crompton, Holland. Oaklyn, Cross Oak-road, Berkhamsted.  
 1901. †CROMPTON, Colonel R. E., C.B., M.Inst.C.E. (Pres. G, 1901.) Kensington-court, W.  
 1914. †Cronin, J. Botanic Gardens, South Yarra, Australia.  
 1916. §Crook, C. W., B.A., B.Sc. 10 West Bank, Stamford Hill, N.  
 1887. †CROOK, HENRY T., M.Inst.C.E. Lancaster-avenue, Manchester.  
 1898. §CROOKE, WILLIAM, B.A. (Pres. H, 1910; Council, 1910-16.) Langton House, Charlton Kings, Cheltenham.  
 1865. §CROOKES, Sir WILLIAM, O.M., D.Sc., F.R.S., V.P.C.S. (PRESIDENT, 1898; Pres. B, 1886; Council, 1885-91.) 7 Kensington Park-gardens, W.  
 1897. \*CROOKSHANK, E. M., M.B. Saint Hill, East Grinstead, Sussex.  
 1909. †Crosby, Rev. E. H. Lewis, B.D. 36 Rutland-square, Dublin.  
 1905. †Crosfield, Hugh T. Walden, Coombe-road, Croydon.  
 1894. \*Crosfield, Miss Margaret C. Undercroft, Reigate.  
 1904. §Cross, Professor Charles R. Massachusetts Institute of Technology, Boston, U.S.A.

Year of  
Election.

1905. §Cross, Robert. 13 Moray-place, Edinburgh.  
 1904. \*CROSSLEY, Professor A. W., D.Sc., Ph.D., F.R.S. 46 Lindfield-gardens, Hampstead, N.W.  
 1908. †Crossley, F. W. 30 Molesworth-street, Dublin.  
 1897. \*Crosweiler, Mrs. W. T. Kent Lodge, Sidcup, Kent.  
 1890. \*Crowley, Ralph Henry, M.D. Sollershott W., Letchworth.  
 1910. †Crowthor, Professor C., M.A., Ph.D. The University, Leeds.  
 1910. \*CROWTHER, JAMES ARNOLD, Sc.D. St. John's College, Cambridge.  
 1911. §Crush, S. T. Care of Messrs. Yarrow & Co., Ltd., Scotstoun West, Glasgow.  
 1916. §Cullen, W. H. 53 Osborne-road, Newcastle-on-Tyne.  
 1883. \*CULVERWELL, EDWARD P., M.A., Professor of Education in Trinity College, Dublin.  
 1883. †Culverwell, T. J. H. Litfield House, Clifton, Bristol.  
 1914. \*Cuming, James. 65 William-street, Melbourne.  
 1914. \*Cuming, W. Fehon. Hyde-street, Yarraville, Victoria.  
 1911. †Cumming, Alexander Charles, D.Sc. Chemistry Department, University of Edinburgh.  
 1911. §CUMMINS, Major H. A., M.D., C.M.G., Professor of Botany in University College, Cork.  
 1861. \*Cunliffe, Edward Thomas. The Parsonage, Handforth, Manchester.  
 1861. \*Cunliffe, Peter Gibson. Dunedin, Handforth, Manchester.  
 1905. †Cunningham, Miss A. 2 St. Paul's-road, Cambridge.  
 1882. \*CUNNINGHAM, Lieut.-Colonel ALLAN, R.E., A.I.C.E. 20 Essex-villas, Kensington, W.  
 1905. †Cunningham, Andrew. Earlsferry, Campground-road, Mowbray, South Africa.  
 1911. †Cunningham, E. St. John's College, Cambridge.  
 1885. †CUNNINGHAM, J. T., M.A. 63 St. Mary's-grove, Chiswick, W.  
 1869. †CUNNINGHAM, ROBERT O., M.D., F.L.S., Professor of Natural History in Queen's College, Belfast.  
 1883. \*CUNNINGHAM, Ven. Archdeacon W., D.D., D.Sc. (Pres. F, 1891, 1905.) Trinity College, Cambridge.  
 1900. \*Cunnington, William A., M.A., Ph.D., F.Z.S. 25 Orlando-road, Clapham Common, S.W.  
 1916. §Cunnison, James. Penzance, Bristol-road, Selly Oak, Birmingham.  
 1912. §CUNYNGHAME, Sir HENRY H., K.C.B. (Pres. F, 1912.) Kingham Lodge, Chipping Norton.  
 1914. §Cunynghame, Lady. Kingham Lodge, Chipping Norton.  
 1914. †Curdie, Miss Jessie. Camperdown, Victoria.  
 1913. †Currall, A. E. Streetsbrook-road, Solihull, Birmingham.  
 1908. †Currelly, C. T., M.A., F.R.G.S. United Empire Club, 117 Piccadilly, W.  
 1892. \*Currie, James, M.A., F.R.S.E. Larkfield, Wardie-road, Edinburgh.  
 1905. †Currie, Dr. O. J. Manor House, Mowbray, Cape Town.  
 1902. †Curry, Professor M., M.Inst.C.E. 5 King's-gardens, Hove.  
 1912. †Curtis, Charles. Field House, Cainscross, Stroud, Gloucestershire.  
 1915. †Curtis, Raymond. Highfield, Leek, Staffordshire.  
 1907. †CUSHNY, ARTHUR R., M.D., F.R.S. (Pres. I, 1916), Professor of Pharmacology in University College, Gower-street, W.C.  
 1913. †Cutler, A. E. 5 Charlotte-road, Edgbaston, Birmingham.  
 1913. †Czaplicka, Miss M. A. Somerford College, Oxford.
1910. †DAKIN, Dr. W. J., Professor of Biology in the University of Western Australia, Perth, Western Australia.

Year of  
Election.

1914. †Dakin, Mrs. University of Western Australia, Perth, Western Australia.
1898. \*DALBY, W. E., M.A., B.Sc., F.R.S., M.Inst.C.E. (Pres. G, 1910), Professor of Civil and Mechanical Engineering in the City and Guilds Engineering College, Imperial College of Science and Technology, S.W.
1889. \*Dale, Miss Elizabeth. Garth Cottage, Oxford-road, Cambridge.
1906. §Dale, William, F.S.A., F.G.S. The Lawn, Archer's-road, Southampton.
1907. †DALGLIESH, RICHARD, J.P., D.L. Ashfordby Place, near Melton Mowbray.
1904. \*DALTON, J. H. C., M.D. The Plot, Adams-road, Cambridge.
1862. †DANBY, T. W., M.A., F.G.S. The Crouch, Seaford, Sussex.
1905. †Daniel, Miss A. M. 3 St. John's-terrace, Weston-super-Mare.
1901. \*DANIELL, G. F., B.Sc. Woodberry, Oakleigh Park, N.
1914. §Danks, A. T. 391 Bourke-street, Melbourne.
1896. §Danson, F. C. Tower-buildings, Water-street, Liverpool.
1897. †Darbishire, F. V., B.A., Ph.D. Dorotheenstrasse 12, Dresden 20.
1903. †DARBISHIRE, Dr. OTTO V. The University, Bristol.
1916. §DARNELL, E. Town Hall, Newcastle-on-Tyne.
1905. †Darwin, Lady. Newnham Grange, Cambridge.
1904. \*Darwin, Charles Galton. Newnham Grange, Cambridge.
1882. \*DARWIN, Sir FRANCIS, M.A., M.B., LL.D., D.Sc., F.R.S., F.L.S. (PRESIDENT, 1908; Pres. D, 1891; Pres. K, 1904; Council, 1882-84, 1897-1901.) 10 Madingley-road, Cambridge.
1878. \*DARWIN, HORACE, M.A., F.R.S. The Orchard, Huntingdon-road, Cambridge.
1894. \*DARWIN, Major LEONARD, F.R.G.S. (Pres. E, 1896; Council, 1899-1905.) 12 Egerton-place, South Kensington, S.W.
1910. †Dauncey, Mrs. Thursby. Lady Stewert, Heath-road, Weybridge.
1916. \*Davey, Miss Alice J., M.Sc. 35 Canford-road, Clapham Common, S.W.
1880. \*DAVEY, HENRY, M.Inst.C.E. Conaways, Ewell, Surrey.
1884. †David, A. J., B.A., LL.B. 4 Harcourt-buildings, Temple, E.C.
1914. †DAVID, Professor T. W. EDGEWORTH, C.M.G., D.Sc., F.R.S. The University, Sydney, N.S.W.
1904. †Davidge, H. T., B.Sc., Professor of Electricity in the Ordnance College, Woolwich.
1913. §Davidge, W. R., A.M.Inst.C.E. 63 Lewisham-park, S.E.
1913. †Davidge, Mrs. 63 Lewisham-park, S.E.
1909. †Davidson, A. R. 150 Stradbroke-place, Winnipeg, Canada.
1912. †Davidson, Rev. J. The Manse, Douglas, Isle of Man.
1912. †Davidson, John, M.A., D.Ph. Training College, Small's Wynd, Dundee.
1902. \*Davidson, S. C. Seacourt, Bangor, Co. Down.
1914. †Davidson, W. R. 15 Third-avenue, Hove.
1910. \*Davie, Robert C., M.A., B.Sc. Royal Botanic Garden, Edinburgh.
1887. \*Davies, H. Rees. Treborth, Bangor, North Wales.
1904. §Davies, Henry N., F.G.S. Ottery House, Bristol-road, Weston-super-Mare.
1906. †Davies, S. H. Ryecroft, New Earswick, York.
1893. \*Davies, Rev. T. Witton, B.A., Ph.D., D.D., Professor of Semitic Languages in University College, Bangor, North Wales.
1896. \*Davies, Thomas Wilberforce, F.G.S. 41 Park-place, Cardiff.
1870. \*Davis, A. S. St. George's School, Roundhay, near Leeds.
1873. \*Davis, Alfred. 37 Ladbroke-grove, W.
1896. \*Davis, John Henry Grant. Dolobran, Wood Green, Wednesbury.



Year of  
Election.

1910. †Davis, Captain John King. 9 Regent-street, W.  
 1905. †Davis, Luther. P.O. Box 898, Johannesburg.  
 1885. \*Davis, Rev. Rudolf. 18 Alexandra-road, Gloucester.  
 1886. †DAVISON, CHARLES, D.Sc. 16 Manor-road, Birmingham.  
 1905. †DAVY, JOSEPH BURTT, F.R.G.S., F.L.S. *Care of Messrs. Dulau & Co., 37 Soho-square, W.*  
 1912. †Dawkins, Miss Ella Boyd. Fallowfield House, Fallowfield, Manchester.  
 1864. †DAWKINS, W. BOYD, D.Sc., F.R.S., F.S.A., F.G.S. (Pres. C, 1888; Council, 1882-88.) Fallowfield House, Fallowfield, Manchester.  
 1885. \*Dawson, Lieut.-Colonel H. P., R.A. Hurlington Hall, Burnsall, Skipton-in-Craven.  
 1901. \*Dawson, P. The Acre, Maryhill, Glasgow.  
 1905. †Dawson, Mrs. The Acre, Maryhill, Glasgow.  
 1912. \*Dawson, Shepherd, M.A., B.Sc. Drumchapel, near Glasgow.  
 1906. †Dawson, William Clarke. Whitefriargate, Hull.  
 1859. \*Dawson, Captain W. G. Abbots Morton, near Worcester.  
 1900. †Deacon, M. Whittington House, near Chesterfield.  
 1909. §Dean, George, F.R.G.S. 14 Evelyn-mansions, Queen's Club-gardens, W.  
 1915. †Dean, H. R. Pathological Department, The University, Manchester.  
 1901. \*Deasy, Captain H. H. P. Cavalry Club, 127 Piccadilly, W.  
 1914. †Debenham, Frank. Caius College, Cambridge.  
 1893. \*Deeley, R. M., M.Inst.C.E., F.G.S. Abbeyfield, Salisbury-avenue, Harpenden, Herts.  
 1911. †Delahunt, C. G. The Municipal College, Portsmouth.  
 1878. †DELANY, Very Rev. WILLIAM, LL.D. University College, Dublin.  
 1915. †Delepiné, Sheridan. Public Health Laboratory, York-place, Manchester.  
 1908. \*Delf, Miss E. M. Girton College, Cambridge.  
 1914. †Delprat, G. D. Equitable-building, Collins-street, Melbourne.  
 1902. \*DENDY, ARTHUR, D.Sc., F.R.S., F.L.S. (Pres. D, 1914; Council, 1912- ), Professor of Zoology in King's College, London, W.C.  
 1914. †Dendy, Miss. Vale Lodge, Hampstead, N.W.  
 1913. \*Denman, Thomas Hercy. 17 Churchgate, Retford, Nottinghamshire.  
 1908. †Dennehy, W. F. 23 Leeson-park, Dublin.  
 1889. \*DENNY, ALFRED, M.Sc., F.L.S., Professor of Zoology in the University of Sheffield. Cliffside, Ranmoor-crescent, Sheffield.  
 1909. §Dent, Edward, M.A. 2 Carlos-place, W.  
 1874. \*Derham, Walter, M.A., LL.M., F.G.S. Junior Carlton Club, Pall Mall, S.W.  
 1907. \*Desch, Cecil H., D.Sc., Ph.D. 3 Kelvinside-terrace North, Glasgow.  
 1908. †Despard, Miss Kathleen M. 6 Sutton Court-mansions, Grove Park-terrace, Chiswick, W.  
 1894. \*Deverell, F. H. 7 Grote's-place, Blackheath, S.E.  
 1868. \*DEWAR, Sir JAMES, M.A., LL.D., D.Sc., F.R.S., F.R.S.E., V.P.C.S., Fullerian Professor of Chemistry in the Royal Institution, London, and Jacksonian Professor of Natural and Experimental Philosophy in the University of Cambridge. (PRESIDENT, 1902; Pres. B, 1879; Council, 1883-88.) 1 Scroope-terrace, Cambridge.  
 1881. †Dewar, Lady. 1 Scroope-terrace, Cambridge.  
 1884. \*Dewar, William, M.A. Horton House, Rugby.

Year of  
Election.

1889. †Dickinson, A. H. 52 Dean-street, Newcastle-on-Tyne.  
 1914. †Dickinson, Miss Desiree. Menzies' Hotel, Melbourne.  
 1916. §Dickinson, Miss M. Eastern House, 159 Marine-parade, Brighton.  
 1908. §Dicks, Henry. Haslecourt, Horsell, Woking.  
 1904. †Dickson, Right Hon. Charles Scott, K.C., LL.D., M.P. Carlton Club, Pall Mall, S.W.  
 1881. †Dickson, Edmund, M.A., F.G.S. Claughton House, Garstang, R.S.O., Lancashire.  
 1887. §Dickson, H. N., D.Sc., F.R.S.E., F.R.G.S. (Pres. E, 1913; Council, 1915- ), Professor of Geography in University College, Reading. 160 Castle-hill, Reading.  
 1902. §Dickson, James D. Hamilton, M.A., F.R.S.E. 6 Cranmer-road, Cambridge.  
 1913. \*Dickson, T. W. 60 Jeffrey's-road, Clapham, S.W.  
 1908. †Dines, J. S. Pyrton Hill, Watlington.  
 1901. §Dines, W. H., B.A., F.R.S. Benson, Wallingford, Berks.  
 1905. §DIXEY, F. A., M.A., M.D., F.R.S. (Council, 1913- .) Wadham College, Oxford.  
 1915. §Dixon, Miss A. Broadwater, 43 Pine-road, Didsbury.  
 1899. \*DIXON, A. C., D.Sc., F.R.S., Professor of Mathematics in Queen's University, Belfast. Hurstwood, Malone Park, Belfast.  
 1874. \*DIXON, A. E., M.D., Professor of Chemistry in University College, Cork.  
 1900. †Dixon, A. Francis, Sc.D., Professor of Anatomy in the University of Dublin.  
 1905. †Dixon, Miss E. K. Fern Bank, St. Bees, Cumberland.  
 1908. †Dixon, Edward K., M.E., M.Inst.C.E. Castlebar, Co. Mayo.  
 1888. †Dixon, Edward T. Racketts, Hythe, Hampshire.  
 1908. \*DIXON, ERNEST, B.Sc., F.G.S. The Museum, Jermyn-street, S.W.  
 1900. \*Dixon, Lieut.-Colonel George, M.A. Fern Bank, St. Bees, Cumberland.  
 1879. \*DIXON, HAROLD B., M.A., F.R.S., F.C.S. (Pres. B, 1894; Council, 1913- ), Professor of Chemistry in the Victoria University, Manchester.  
 1914. †Dixon, Mrs. H. B., Beechey House, Wilbraham-road, Fallowfield, Manchester.  
 1902. †DIXON, HENRY H., D.Sc., F.R.S., Professor of Botany in the University of Dublin. Clevedon, Temple-road, Dublin.  
 1913. †Dixon, S. M., M.A., M.Inst.C.E., Professor of Civil Engineering in the Imperial College of Science and Technology, London, S.W.  
 1908. \*Dixon, Walter, F.R.M.S. Derwent, 30 Kelvinside-gardens, Glasgow.  
 1907. \*DIXON, Professor WALTER E., F.R.S. The Museums, Cambridge.  
 1914. †Dixon, Mrs. W. E. The Grove, Whittlesford, Cambridge.  
 1902. †Dixon, W. V. *Scotch Quarter, Carrickfergus.*  
 1896. §Dixon-Nuttall, F. R. Ingleholme, Eccleston Park, Prescott.  
 1890. †Dobbie, Sir James J., D.Sc., LL.D., F.R.S., Principal of the Government Laboratories, 13 Clement's Inn-passage, W.C.  
 1885. §Dobbin, Leonard, Ph.D. The University, Edinburgh.  
 1860. \*Dobbs, Archibald Edward, M.A., J.P., D.L. Castle Dobbs, Carrickfergus, Co. Antrim.  
 1902. †Dobbs, F. W., M.A. Eton College, Windsor.  
 1914. †Docker, His Honour Judge E. B., M.A. Mostyn, Elizabeth Bay, Sydney, N.S.W.  
 1917. \*Docker, Frank Dudley, C.B. The Gables, Kenilworth.  
 1908. †DODD, Hon. Mr. Justice. 26 Fitzwilliam-square, Dublin.  
 1876. †Dodds, J. M. St. Peter's College, Cambridge.  
 1912. †Don, A. W. R. The Lodge, Broughty Ferry, Forfarshire.

Year of  
Election.

1904. †Doncaster, Leonard, M.A., F.R.S. Museum of Zoology, Cambridge.  
 1896. †Donnan, F. E. Ardenmore-terrace, Holywood, Ireland.  
 1901. †Donnan, F. G., M.A., Ph.D., F.R.S., Professor of Chemistry in University College, Gower-street, W.C.  
 1915. §Doodson, Arthur T., M.Sc. 1 Manor-road, Shaw, Lancashire.  
 1905. §Dornan, Rev. S. S. P.O. Box 510, Bulawayo, South Rhodesia, South Africa.  
 1863. \*Doughty, Charles Montagu. 26 Grange-road, Eastbourne.  
 1909. †Douglas, A. J., M.D. City Health Department, Winnipeg, Canada.  
 1909. \*Douglas, James. 99 John-street, New York, U.S.A.  
 1912. †Doune, Lord. Kinfauns Castle, Perth.  
 1884. \*Dowling, D. J. Sycamore, Clive-avenue, Hastings.  
 1881. \*Dowson, J. Emerson, M.Inst.C.E. Landhurst Wood, Hartfield, Sussex.  
 1913. †Drapocoli, J. N. Pollard's Wood Grange, Chalfont St. Giles, Buckinghamshire.  
 1892. \*Dreghorn, David, J.P. Greenwood, Pollokshields, Glasgow.  
 1912. §Drever, James, M.A., B.Sc., D.Phil. 36 Morningside-grove, Edinburgh.  
 1905. †Drew, H. W., M.B., M.R.C.S. Mocollup Castle, Ballyduff, S.O., Co. Waterford.  
 1906. \*Drew, Joseph Webster, M.A., LL.M. Hatherley Court, Cheltenham.  
 1906. \*Drew, Mrs. Hatherley Court, Cheltenham.  
 1908. †Droop, J. P. 11 Cleveland-gardens, Hyde Park, W.  
 1893. §DRUCE, G. CLARIDGE, M.A., F.L.S. (Local Sec. 1894.) Yardley Lodge, 9 Crick-road, Oxford.  
 1909. \*Drugman, Julien, Ph.D., M.Sc. 117 Rue Gachard, Brussels.  
 1889. †Drummond, Dr. David. 6 Saville-place, Newcastle-on-Tyne.  
 1907. †Drysdale, Charles V., D.Sc. Queen Anne's-chambers, S.W.  
 1892. †Du Bois, Professor Dr. H. Herwarthstrasse 4, Berlin, N.W.  
 1856. \*DUCIE, The Right Hon. HENRY JOHN REYNOLDS MORETON, Earl of, G.C.V.O., F.R.S., F.G.S. 16 Portman-square, W.  
 1870. †Duckworth, Henry, F.L.S., F.G.S. 7 Grey Friars, Chester.  
 1900. \*Duckworth, W. L. H., M.D., Sc.D. Jesus College, Cambridge.  
 1895. \*Duddell, William, F.R.S. 47 Hans-place, S.W.  
 1914. †Duff, Frank Gee. 31 Queen-street, Melbourne.  
 1914. †Duffield, D. Walter. 13 Cowra-chambers, Grenfell-street, Adelaide, South Australia.  
 1912. §Duffield, Francis A., M.B. Home Lea, Four Oaks, Sutton Coldfield.  
 1904. \*DUFFIELD, Professor W. GEOFFREY, D.Sc. University College, Reading.  
 1890. †Dufton, S. F. Trinity College, Cambridge.  
 1899. \*Dugdale-Bradley, J. W., M.Inst.C.E. Westminster City Hall, Charing Cross-road, W.C.  
 1911. †Dummer, John. 85 Cottage-grove, Southsea.  
 1914. †Dun, W. S. Mines Department, Sydney, N.S.W.  
 1909. †Duncan, D. M., M.A. 83 Spence-street, Winnipeg, Canada.  
 1916. §Dunkerley, G. D. 124 Mildred-avenue, Watford.  
 1910. †Dunn, Rev. J. Road Hill Vicarage, Bath.  
 1916. §Dunn, Dr. J. T. Fellside, Low Fell, Gateshead.  
 1876. †Dunnachie, James. 48 West Regent-street, Glasgow. .  
 1916. §Dunning, James E. 3 Lombard-street, E.C.  
 1884. §Dunnington, Professor F. P. University of Virginia, Charlottesville, Virginia, U.S.A.  
 1893. \*Dunstan, M. J. R., Principal of the South-Eastern Agricultural College, Wye, Kent.  
 1891. †Dunstan, Mrs. South-Eastern Agricultural College, Wye, Kent.

Year of  
Election.

1885. \*DUNSTAN, WYNDHAM R., C.M.G., M.A., LL.D., F.R.S., F.C.S. (Pres. B, 1906; Council, 1905-08), Director of the Imperial Institute, S.W.
1911. †Dupree, Colonel Sir W. T. Craneswater, Southsea.
1913. §Durie, William. 31 Priory-road, Bedford Park, Chiswick, W.
1914. §DU TOIT, A. L., D.Sc. South African Museum, Cape Town.
1914. †Du Toit, Mrs. South African Museum, Cape Town.
1905. §Dutton, C. L. O'Brien. High Commissioner's Office, Pretoria.
1910. †Dutton, F. V., B.Sc. County Agricultural Laboratories, Richmond-road, Exeter.
1895. \*DWERRYHOUSE, ARTHUR R., D.Sc., F.G.S. Deraness, Deramore Park, Belfast.
1911. †Dye, Charles. Woodcrofts, London-road, Portsmouth.
1885. \*Dyer, Henry, M.A., D.Sc., LL.D. 8 Highburgh-terrace, Dowanhill, Glasgow.
1895. §Dymond, Thomas S., F.C.S. Savile Club, Piccadilly, W.
1905. \*DYSON, Sir F. W., M.A., LL.D., F.R.S. (Pres. A, 1915; Council, 1905-11, 1914- ), Astronomer Royal. Royal Observatory, Greenwich, S.E.
1910. †Dyson, W. H. Maltby Colliery, near Rotherham, Yorkshire.
1912. †Earland, Arthur, F.R.M.S. 34 Granville-road, Watford.
1899. †East, W. H. Municipal School of Art, Science, and Technology, Dover.
1909. \*Easterbrook, C. C., M.A., M.D. Crichton Royal Institution, Dumfries.
1893. \*Ebbs, Alfred B. Tuborg, Plaistow-lane, Bromley, Kent.
1906. \*Ebbs, Mrs. A. B. Tuborg, Plaistow-lane, Bromley, Kent.
1909. †Eccles, J. R. Gresham's School, Holt, Norfolk.
1903. \*ECCLES, W. H., D.Sc., Professor of Physics in the City and Guilds of London Technical College, Leonard-street, Finsbury, E.C.
1908. \*Eddington, A. S., M.A., M.Sc., F.R.S., Plumian Professor of Astronomy and Experimental Philosophy in the University of Cambridge. The Observatory, Cambridge.
1870. \*Eddison, John Edwin, M.D., M.R.C.S. The Lodge, Adel, Leeds.
1911. \*Edge, S. F. Gallops Homestead, Ditchling, Sussex.
1911. \*Edgell, Miss Beatrice. Bedford College, Regent's Park, N.W.
1884. \*Edgell, Rev. R. Arnold, M.A. Beckley Rectory, East Sussex.
1887. §EDGEWORTH, F. Y., M.A., D.C.L., F.S.S. (Pres. F, 1889; Council, 1879-86, 1891-98), Professor of Political Economy in the University of Oxford. All Souls College, Oxford.
1870. \*Edmonds, F. B. 6 Clement's Inn, W.C.
1883. †Edmonds, William. Wiscombe Park, Colyton, Devon.
1888. \*Edmunds, Henry. Moulsecombe-place, Brighton.
1901. \*EDRIDGE-GREEN, F. W., M.D., F.R.C.S. 99 Walm-lane, Willesden Green, N.W.
1914. †Edwards, A. F. Chemical Department, The University, Manchester.
1915. †Edwards, C. A. 26 Lyndhurst-road, Withington, Manchester.
1899. §Edwards, E. J., Assoc.M.Inst.C.E. 13 Acris-street, Wandsworth Common, S.W.
1913. §Edwards, E. J. Royal Technical College, Glasgow.
1901. †Eggar, W. D. Eton College, Windsor.
1909. †Eggertson, Arni. 120 Emily-street, Winnipeg, Canada.
1909. §Ehrenborg, G. B. 1 Dean-road, Croydon.

Year of  
Election.

1907. \*Elderton, W. Palin. 24 Mount Ephraim-road, Streatham, S.W.  
 1890. †Elford, Percy. 115 Woodstock-road, Oxford.  
 1913. †Elkington, Herbert F. Clunes, Wentworth-road, Sutton Coldfield.  
 1901. \*Elles, Miss Gertrude L., D.Sc. Newnham College, Cambridge.  
 1915. §Ellinger, Barnard, F.S.S. 28 Oxford-street, Manchester.  
 1904. †Elliot, Miss Agnes I. M. Newnham College, Cambridge.  
 1904. †Elliot, R. H. Clifton Park, Kelso, N.B.  
 1905. †Elliott, C. C., M.D. Church-square, Cape Town.  
 1883. \*ELLIOTT, EDWIN BAILEY, M.A., F.R.S., F.R.A.S., Waynflete Professor of Pure Mathematics in the University of Oxford. 4 Bardwell-road, Oxford.  
 1912. §Elliott, Dr. W. T., F.Z.S. 21 Bennett's-hill, Birmingham.  
 1906. \*Ellis, David, D.Sc., Ph.D. Royal Technical College, Glasgow.  
 1875. \*Ellis, H. D. 12 Gloucester-terrace, Hyde Park, W.  
 1906. §ELLIS, HERBERT. The Gynsills, Groby-road, Leicester.  
 1913. †Ellis, Herbert Willoughby, Assoc.M.Inst.C.E. Holly Hill, Berkswell, Warwickshire.  
 1891. †Ellis, Miss M. A. Care of Miss Rice, 11 Canterbury-road, Oxford.  
 1906. †ELMHIRST, CHARLES E. (Local Sec. 1906.) 29 Mount-vale, York.  
 1910. †Elmhirst, Richard. Marine Biological Station, Millport.  
 1911. †Elwes, H. J., F.R.S. Colesborne Park, near Cheltenham.  
 1884. †Emery, Albert H. Stamford, Connecticut, U.S.A.  
 1905. †Epps, Mrs. Dunhurst, Petersfield, Hampshire.  
 1894. †Erskine-Murray, J., D.Sc., F.R.S.E. 4 Great Winchester-street, E.C.  
 1914. †Erson, Dr. E. G. Leger. 123 Collins-street, Melbourne.  
 1887. \*Estcourt, Charles, F.I.C. 5 Seymour-grove, Old Trafford, Manchester.  
 1887. \*Estcourt, P. A., F.C.S., F.I.C. 5 Seymour-grove, Old Trafford, Manchester.  
 1911. †ETHERTON, G. HAMMOND. (Local Sec. 1911.) Town Hall, Portsmouth.  
 1897. \*Evans, Lady. Care of Union of London and Smiths Bank, Berkhamsted, Herts.  
 1889. \*EVANS, A. H., M.A. 9 Harvey-road, Cambridge.  
 1905. †EVANS, Mrs. A. H. 9 Harvey-road, Cambridge.  
 1870. \*EVANS, Sir ARTHUR JOHN, M.A., LL.D., F.R.S., F.S.A. (PRESIDENT; Pres. H, 1896.) Youlbury, Berks, near Oxford.  
 1908. †EVANS, Rev. Henry, D.D., Commissioner of National Education, Ireland. Blackrock, Co. Dublin.  
 1887. \*EVANS, Mrs. Isabel. Lyndhurst, Upper Chorlton-road, Whalley Range, Manchester.  
 1905. †EVANS, Ivor H. N. 9 Harvey-road, Cambridge.  
 1913. †EVANS, J. Jameson. 41 Newhall-street, Birmingham.  
 1910. \*EVANS, JOHN W., D.Sc., LL.B., F.G.S. 75 Craven Park-road, Harlesden, N.W.  
 1905. †EVANS, R. O. Ll. Broom Hall, Chwilog, R.S.O., Carnarvonshire.  
 1910. †EVANS, T. J. The University, Sheffield.  
 1865. \*EVANS, William. The Spring, Kenilworth.  
 1909. †EVANS, W. SANFORD, M.A. (Local Sec. 1909.) 43 Edmonton-street, Winnipeg.  
 1902. \*Everett, Percy W. Oaklands, Elstree, Hertfordshire.  
 1883. †Eves, Miss Florence. Uxbridge.  
 1914. †Ewart, Professor A. J., D.Sc. The University, Melbourne.  
 1881. †EWART, J. COSSAR, M.D., F.R.S. (Pres. D, 1901), Professor of Natural History in the University of Edinburgh.

Year of  
Election.

1874. †EWART, Sir W. QUARTUS, Bart. (Local Sec. 1874.) Glenmachan, Belfast.
1913. \*EWEN, J. T. 104 King's-gate, Aberdeen.
1913. \*EWEN, Mrs. J. T. 104 King's-gate, Aberdeen.
1876. \*EWING, Sir JAMES ALFRED, K.C.B., M.A., LL.D., F.R.S., F.R.S.E., M.Inst.C.E. (Pres. G, 1906), Principal of the University of Edinburgh.
1914. §Ewing, Mrs. Peter. The Frond, Uddingston, Glasgow.
1884. \*EYERMAN, John, F.Z.S. Oakhurst, Easton, Pennsylvania, U.S.A.
1912. §EYRE, Dr. J. VARGAS. South-Eastern Agricultural College, Wye, Kent.
1906. \*Faber, George D. 14 Grosvenor-square, W.
1901. \*Fairgrieve, M. McCallum. 37 Queen's-crescent, Edinburgh.
1865. \*FAIRLEY, THOMAS, F.R.S.E., F.C.S. 8 Newton-grove, Leeds.
1910. †Falconer, J. D., M.A., D.Sc. Care of Postmaster, Naraguta, Northern Nigeria.
1908. †Falconer, Robert A., M.A. 44 Merrion-square, Dublin.
1896. §Falk, Herman John, M.A. Thorshill, West Kirby, Cheshire.
1902. §Fallaize, E. N., B.A. Vinchelez, Chase Court-gardens, Windmill-hill, Enfield.
1907. \*Fantham, H. B., M.A., D.Sc., Professor of Zoology in the School of Mines and Technology, University of South Africa, Johannesburg.
1902. †Faren, William. 11 Mount Charles, Belfast.
1892. \*FARMER, J. BRETLAND, M.A., F.R.S., F.L.S. (Pres. K, 1907; Council, 1912-14.) South Park, Gerrard's Cross.
1905. †Farrar, Edward. P.O. Box 1242, Johannesburg.
1913. †Farrow, F. D. Rhodes University College, Grahamstown, South Africa.
1903. §Faulkner, Joseph M. 17 Great Ducie-street, Strangeways, Manchester.
1913. §Fawcett, C. B. University College, Southampton.
1890. \*Fawcett, F. B. 1 Rockleaze-avenue, Sneyd Park, Bristol.
1906. §Fawcett, Henry Hargreave. Thorncombe, near Chard, Somerset.
1900. †FAWCETT, J. E., J.P. (Local Sec. 1900.) Low Royd, Apperley Bridge, Bradford.
1902. \*Fawsitt, C. E., Ph.D., Professor of Chemistry in the University of Sydney, New South Wales.
1911. \*Fay, Mrs. A. Q. Chedworth, Rustat-road, Cambridge.
1909. \*Fay, Charles Ryle, M.A. Christ's College, Cambridge.
1906. \*Fearnshides, Edwin E., M.A., M.B., B.Sc. London Hospital, E.
1901. \*FEARNSIDES, W. G., M.A., F.G.S., Sorby Professor of Geology in the University of Sheffield. 10 Silver Birch-avenue, Fulwood, Sheffield.
1910. \*Fearnshides, Mrs. 10 Silver Birch-avenue, Fulwood, Sheffield.
1905. †Feilden, Colonel H. W., C.B., F.R.G.S., F.G.S. Burwash, Sussex.
1900. \*Fennell, William John. 2 Wellington-place, Belfast.
1904. †Fenton, H. J. H., M.A., Sc.D., F.R.S. 19 Brookside, Cambridge.
1914. †Ferguson, E. R. Gordon-street, Footscray, Victoria, Australia.
1901. †Ferguson, R. W. 16 Linden-road, Bournville, near Birmingham.
1863. \*Fernie, John. Box No. 2, Hutchinson, Kansas, U.S.A.
1910. \*Ferranti, S. Z. de, M.Inst.C.E. Grindleford, near Sheffield.
1905. \*FERRAR, H. T., M.A., F.G.S. Care of A. Anderson, Esq., St. Martin's, Christchurch, New Zealand.

Year of  
Election.

1914. †FERRAR, Mrs. Care of A. Anderson, Esq., St. Martin's, Christchurch, New Zealand.
1873. †FERRIER, Sir DAVID, M.A., M.D., LL.D., F.R.S. 34 Cavendish-square, W.
1909. †Fetherstonhaugh, Professor Edward P., B.Sc. 119 Betourney-street, Winnipeg, Canada.
1882. §FEWINGS, James, B.A., B.Sc. King Edward VI. Grammar School, Southampton.
1915. †FIELD, A. B. Kingslea, Marple, near Stockport.
1913. †FIELD, Miss E. E. Hollywood, Egham Hill, Surrey.
1897. †FIELD, George Wilton, Ph.D. Room 158, State House, Boston, Massachusetts, U.S.A.
1907. \*FIELDS, Professor J. C., F.R.S. The University, Toronto, Canada.
1906. §FILON, L. N. G., D.Sc., F.R.S., Professor of Applied Mathematics in the University of London. Lynton, Haling Park-road, Croydon.
1905. †FINCHAM, G. H. Hopewell, Invami, Cape Colony.
1905. §FINDLAY, ALEXANDER, M.A., Ph.D., D.Sc., Professor of Chemistry in University College, Aberystwyth.
1904. \*FINDLAY, J. J., Ph.D., Professor of Education in the Victoria University, Manchester. Ruperra, Victoria Park, Manchester.
1912. §FINLAYSON, Daniel, F.L.S. Seed Testing Laboratory, Wood Green, N.
1902. †FINNEGAN, J., M.A., B.Sc. Kelvin House, Botanic-avenue, Belfast.
1902. †FISHER, J. R. Cranfield, Fortwilliam Park, Belfast.
1909. †FISHER, James, K.C. 216 Portage-avenue, Winnipeg, Canada.
1875. \*FISHER, W. W., M.A., F.C.S. 5 St. Margaret's-road, Oxford.
1887. \*FISON, Alfred H., D.Sc. 47 Dartmouth-road, Willesden Green, N.W.
1871. \*FISON, Sir FREDERICK W., Bart., M.A., F.C.S. Boarzell, Hurst Green, Sussex.
1885. \*FITZGERALD, Professor MAURICE, B.A. (Local Sec. 1902.) Fairholme, Monkstown, Co. Dublin.
1894. †FITZMAURICE, Sir MAURICE, C.M.G., M.Inst.C.E. London County Council, Spring-gardens, S.W.
1888. \*FITZPATRICK, Rev. THOMAS C., President of Queens' College, Cambridge.
1904. †FLATHER, J. H., M.A. Camden House, 90 Hills-road, Cambridge.
1915. †FLECK, Alexander. Blenheim-avenue, Stepps, near Glasgow.
1915. \*FLEMING, Arthur P. M. West Gables, Hale-road, Hale, Cheshire.
1913. †FLEMING, Professor J. A., D.Sc., F.R.S. University College, Gower-street, W.C.
1904. †FLEMING, James. 25 Kelvinside-terrace South, Glasgow.
1892. †FLETCHER, George, F.G.S. Mona, Shankhill, Co. Dublin.
1888. \*FLETCHER, Sir LAZARUS, M.A., Ph.D., F.R.S., F.G.S., F.C.S. (Pres. C, 1894), Director of the Natural History Museum, Cromwell-road, S.W. 35 Woodville-gardens, Ealing, W.
1915. §FLETCHER, Leonard R. Woodfields, Leigh, Lancashire.
1908. \*FLETCHER, W. H. B. Aldwick Manor, Bognor, Sussex.
1901. †FLETT, J. S., M.A., D.Sc., F.R.S., F.R.S.E. Geological Survey Office, 33 George-square, Edinburgh.
1906. \*FLEURE, H. J., D.Sc., Professor of Zoology and Geology in University College, Aberystwyth.
1905. \*FLINT, Rev. W., D.D. Houses of Parliament, Cape Town.
1913. \*FLORENCE, P. Sargent, B.A. Caius College, Cambridge.
1889. †FLOWER, Lady. 26 Stanhope-gardens, S.W.

Year of  
Election.

1890. \*FLUX, A. W., M.A. Board of Trade, Gwydyr House, Whitehall, S.W.
1914. †Flynn, Professor T. Thomson. University of Tasmania, Hobart.
1877. †Foale, William. The Croft, Madeira Park, Tunbridge Wells.
1903. †Foord-Kelcey, W., *Professor of Mathematics in the Royal Military Academy, Woolwich. The Shrubbery, Shooter's Hill, S.E.*
1911. †Foran, Charles. 72 Elm-grove, Southsea.
1906. §Forbes, Charles Mansfeldt. 14 New-street, York.
1914. †Forbes, E. J. P.O. Box 1604, Sydney, N.S.W.
1914. †Forbes, Mrs. E. J. P.O. Box 1604, Sydney, N.S.W.
1873. \*FORBES, GEORGE, M.A., F.R.S., F.R.S.E., M.Inst.C.E. 11 Little College-street, Westminster, S.W.
1883. †FORBES, HENRY O., LL.D., F.Z.S. Redcliffe, Beaconsfield, Bucks.
1905. †FORBES, Lieut.-Colonel W. LACHLAN. Army and Navy Club, Pall Mall, S.W.
1875. \*FORDHAM, Sir GEORGE. Odsey, Ashwell, Baldock, Herts.
1909. †FORGET, The Hon. A. E. Regina, Saskatchewan, Canada.
1887. †FORREST, The Right Hon. Sir JOHN, G.C.M.G., F.R.G.S., F.G.S. Perth, Western Australia.
1915. §Forrester, Robert B. Marischal College, Aberdeen.
1902. \*Forster, M. O., Ph.D., D.Sc., F.R.S. Queen Anne's-mansions, S.W.
1883. †FORSYTH, Professor A. R., M.A., D.Sc., F.R.S. (Pres. A, 1897, 1905; Council, 1907-09.) The Manor House, Marylebone, N.W.
1911. †Foster, F. G. Ivydale, London-road, Portsmouth.
1857. \*FOSTER, GEORGE CAREY, B.A., LL.D., D.Sc., F.R.S. (TRUSTEE, 1916-; GENERAL TREASURER, 1898-1904; Pres. A, 1877; Council, 1871-76, 1877-82.) Ladywalk, Rickmansworth.
1901. †Foster, T. Gregory, Ph.D., Provost of University College, London. University College, Gower-street, W.C.
1911. †FOSTER, Sir T. SCOTT, J.P. Town Hall, Portsmouth.
1911. †Foster, Lady Scott. Braemar, St. Helen's-parade, Southsea.
1903. †FOURCADE, H. G. P.O., Storms River, Humansdorp, Cape Colony.
1905. §Fowlds, Hiram. 65 Devonshire-street, Keighley, Yorkshire.
1909. §Fowlds, Mrs. 65 Devonshire-street, Keighley, Yorkshire.
1912. †Fowler, A., F.R.S., Assistant Professor of Physics in the Imperial College of Science and Technology, S.W. 19 Rusthall-avenue, Bedford Park, W.
1883. \*Fox, Charles. The Pynes, Warlingham-on-the-Hill, Surrey.
1883. †FOX, Sir CHARLES DOUGLAS, M.Inst.C.E. (Pres. G, 1896.) Cross Keys House, 56 Moorgate-street, E.C.
1904. \*Fox, Charles J. J., B.Sc., Ph.D., Professor of Chemistry in the Presidency College of Science, Poona, India.
1904. §Fox, F. Douglas, M.A., M.Inst.C.E. 19 The Square, Kensington, W.
1905. †Fox, Mrs. F. Douglas. 19 The Square, Kensington, W.
1883. †Fox, Howard, F.G.S. Rosehill, Falmouth.
1900. \*Fox, Thomas. Old Way House, Wellington, Somerset.
1909. \*Fox, Wilson Lloyd. Carmino, Falmouth.
1908. †Foxley, Miss Barbara, M.A. 5 Norton Way North, Letchworth.
1881. \*FOXWELL, HERBERT S., M.A., F.S.S. (Council, 1894-97), Professor of Political Economy in University College, London. St. John's College, Cambridge.
1907. \*Fraine, Miss Ethel de, D.Sc., F.L.S. Westfield College, Hampstead, N.W.



Year of  
Election.

1887. \*FRANKLAND, PERCY F., Ph.D., B.Sc., F.R.S. (Pres. B, 1901), Professor of Chemistry in the University of Birmingham.
1913. §FRANKLIN, Cyril H. H. Rodney Y.M.C.A. Huts, Crayford, Kent.
1911. †FRASER, Dr. A. MEARNS. (Local Sec. 1911.) Town Hall, Portsmouth.
1911. †Fraser, Mrs. A. Mearns. Cheyne Lodge, St. Ronan's-road, Portsmouth.
1895. †Fraser, Alexander. 63 Church-street, Inverness.
1871. †FRASER, Sir THOMAS R., M.D., F.R.S., F.R.S.E., Professor of Materia Medica and Clinical Medicine in the University of Edinburgh. 13 Drumsheugh-gardens, Edinburgh.
1911. †Freeman, Oliver, B.Sc. The Municipal College, Portsmouth.
1916. §Freire-Marreco, Miss Barbara. Peter's Croft, Woodham-road, Woking.
1906. §French, Fleet-Surgeon A. M. Langley, Beaufort-road, Kingston-on-Thames.
1909. †French, Mrs. Harriet A. Suite E, Gline's-block, Portage-avenue, Winnipeg, Canada.
1912. §French, Mrs. Harvey. Hambleton Lodge, Childe Okford, Blandford.
1905. †French, Sir Somerset R., K.C.M.G. 100 Victoria-street, S.W.
1886. †FRESHFIELD, DOUGLAS W., F.R.G.S. (Pres. E, 1904.) 1 Airlie-gardens, Campden Hill, W.
1887. \*Fries, Harold H., Ph.D. 92 Reade-street, New York, U.S.A.
1906. †FRITSCH, Dr. F. E. 77 Chatsworth-road, Brondesbury, N.W.
1912. §Frodsham, Miss Margaret, B.Sc. The College School, 34 Cathedral-road, Cardiff.
1892. \*Frost, Edmund, M.D. Chesterfield-road, Eastbourne.
1882. §Frost, Edward P., J.P. West Wrattling Hall, Cambridgeshire.
1911. †Frost, M. E. P. H.M. Dockyard, Portsmouth.
1887. \*Frost, Robert, B.Sc. 55 Kensington-court, W.
1898. †FRY, The Right Hon. Sir EDWARD, G.C.B., D.C.L., LL.D., F.R.S., F.S.A. Failand House, Failand, near Bristol.
1908. †Fry, M. W. J., M.A. 39 Trinity College, Dublin.
1905. \*Fry, Sir William, J.P., F.R.G.S. Wilton House, Merrion-road, Dublin.
1898. †Fryer, Alfred C., Ph.D. 13 Eaton-crescent, Clifton, Bristol.
1872. \*Fuller, Rev. A. 7 Sydenham-hill, Sydenham, S.E.
1912. §Fulton, Angus R., B.Sc. University College, Dundee.
1913. \*Fyson, Philip Furley, B.A., F.L.S. Elmley Lovett, Droitwich.
1910. †GADOW, H. F., Ph.D., F.R.S. (Pres. D, 1913). Zoological Laboratory, Cambridge.
1863. \*Gainsford, W. D. Skendleby Hall, Spilsby.
1906. †Gajjar, Professor T. K., M.A., B.Sc. Techno-Chemical Laboratory, near Girgaum Tram Terminus, Bombay.
1885. \*Galloway, Alexander. Dirgarve, Aberfeldy, N.B.
1875. †GALLOWAY, W. Cardiff.
1887. \*Galloway, W. J. The Cottage, Seymour-grove, Old Trafford, Manchester.
1905. †Galpin, Ernest E. Bank of Africa, Queenstown, Cape of Good Hope.
1913. †GAMBLE, F. W., D.Sc., F.R.S. (Local Sec., 1913), Professor of Zoology and Comparative Anatomy in the University of Birmingham. Scarsfields House, Alvechurch, Worcestershire.
1888. \*GAMBLE, J. SYKES, C.I.E., M.A., F.R.S., F.L.S. Highfield, East Liss, Hants.

Year of  
Election.

1911. †Garbett, Rev. C. F., M.A. The Vicarage, Fratton-road, Portsmouth.
1899. \*Garcke, E. Ditton House, near Maidenhead.
1898. †Garde, Rev. C. L. Skenfrith Vicarage, near Monmouth.
1911. †Gardiner, C. I., M.A., F.G.S. 6 Paragon-parade, Cheltenham.
1912. §Gardiner, F. A., F.L.S. 12 The Ridgeway, Golder's Green, N.W.
1905. †Gardiner, J. H. 59 Wroughton-road, Balham, S.W.
1900. †GARDINER, J. STANLEY, M.A., F.R.S., Professor of Zoology and Comparative Anatomy in the University of Cambridge. Zoological Laboratory, Cambridge.
1887. †GARDINER, WALTER, M.A., D.Sc., F.R.S. St. Awdreys, Hills-road, Cambridge.
1882. \*Gardner, H. Dent, F.R.G.S. Fairmead, 46 The Goffs, Eastbourne.
1912. §GARDNER, WILLOUGHBY, F.L.S. Y Berlfa, Deganwy, North Wales.
1912. §Garfitt, G. A. Cartledge Hall, Holmesfield, near Sheffield.
1915. †Garforth, Sir William, M.Inst.C.E. Snydale Hall, near Pontefract.
1913. \*GARNETT, Principal J. C. MAXWELL, M.A. (Local Sec. 1915.) Westfield, Victoria Park, Manchester.
1905. †Garnett, Mrs. Maxwell, F.Z.S. Westfield, Victoria Park, Manchester.
1887. \*Garnett, Jeremiah. The Grange, Bromley Cross, near Bolton, Lancashire.
1882. †Garnett, William, D.C.L. London County Council, Victoria Embankment, W.C.
1883. †GARSON, J. G., M.D. (ASSIST. GEN. SEC. 1902-04.) Moorcote, Eversley, Winchfield.
1903. \*Garstang, T. James, M.A. Bedales School, Petersfield, Hampshire.
1894. \*GARSTANG, WALTER, M.A., D.Sc., F.Z.S., Professor of Zoology in the University of Leeds.
1874. \*Garstin, John Ribton, M.A., M.R.I.A., F.S.A. Braganstown, Castlebellingham, Ireland.
1889. †GARWOOD, E. J., M.A., F.R.S., F.G.S. (Pres. C, 1913), Professor of Geology in the University of London. University College, Gower-street, W.C.
1905. †Gaskell, Miss C. J. The Uplands, Great Shelford, Cambridge.
1905. †Gaskell, Miss M. A. The Uplands, Great Shelford, Cambridge.
1906. †Gaster, Leon. 32 Victoria-street, S.W.
1913. †GATES, R. R., Ph.D., F.L.S. 14 Well-walk, Hampstead, N.W.
1911. †Gates, W. 'Evening News' Office, Portsmouth.
1916. §Gaunt, J. B. Rutherford College, Newcastle-on-Tyne.
1912. §Gavin, W., M.A. The Farms Offices, Blenheim Park, Woodstock.
1905. \*Gearon, Miss Susan. 26 Oakdale-road, Streatham, S.W.
1885. †GEDDES, Professor PATRICK, F.R.S.E. Outlook Tower, Edinburgh.
1887. †Gee, W. W. Haldane. Oak Lea, Whalley-avenue, Sale.
1867. †GEIKIE, Sir ARCHIBALD, O.M., K.C.B., LL.D., D.Sc., F.R.S., F.R.S.E., F.G.S. (PRESIDENT, 1892; Pres. C, 1867, 1871, 1899; Council, 1888-1891.) Shepherd's Down, Haslemere, Surrey.
1913. §Geldart, Miss Alice M. 2 Cotman-road, Norwich.
1898. \*GEMMILL, JAMES F., M.A., M.D. 12 Anne-street, Hillhead, Glasgow.
1882. \*GENESE, R. W., M.A., Professor of Mathematics in University College, Aberystwyth.
1905. †Gentleman, Miss A. A. 9 Abercromby-place, Stirling.

Year of  
Election.

1912. \*George, H. Trevelyan, M.A., M.R.C.S., L.R.C.P. 33 Amphyll-square, N.W.
1902. \*Gepp, Antony, M.A., F.L.S. British Museum (Natural History), Cromwell-road, S.W.
1899. \*Gepp, Mrs. A. British Museum (Natural History), Cromwell-road, S.W.
1884. \*Gerrans, Henry T., M.A. 20 St. John-street, Oxford.
1917. §Gibbons, A. J. F. Montpellier, Cobo, Côtel, Guernsey.
1909. †GIBBONS, W. M., M.A. (Local Sec. 1910.) The University, Sheffield.
1905. †Gibbs, Miss Lilian S., F.L.S. 22 South-street, Thurloe-square, S.W.
1912. †Gibson, A. H., D.Sc., Professor of Engineering in University College, Dundee.
1916. §Gibson, Alfred Herbert. Presville, Kent-road, Harrogate.
1914. §Gibson, A. J., Ph.D. Central Sugar Mills, Brisbane, Australia.
1916. \*Gibson, Professor C. H., M.A., B.Sc. University Chemical Laboratory, Cambridge.
1915. §Gibson, Charles R. Lynton, Causewood, Pollokshaws, Glasgow.
1901. §Gibson, Professor George A., M.A. 10 The University, Glasgow.
1912. †Gibson, G. E., Ph.D., B.Sc. 16 Woodhall-terrace, Juniper Green.
1916. §Gibson, John E. 8 The Terrace, Riding Mill.
1904. \*Gibson, Mrs. Margaret D., LL.D. Castle Brae, Chesterton-lane, Cambridge.
1912. \*Gibson, Miss Mary H., M.A., Ph.D. Cheshire County Training College, Crewe.
1896. †GIBSON, R. J. HARVEY, M.A., F.R.S.E., Professor of Botany in the University of Liverpool.
1889. \*Gibson, T. G. Lesbury House, Lesbury, R.S.O., Northumberland.
1893. †Gibson, Walcot, F.G.S. 28 Jermyn-street, S.W.
1898. \*Gifford, J. William, F.R.A.S. Oaklands, Chard.
1883. †Gilbert, Lady. Park View, Englefield Green, Surrey.
1884. \*Gilbert, Philip H. 63 Tupper-street, Montreal, Canada.
1916. §Gilchrist, Douglas A., M.Sc., Professor of Agriculture in Armstrong College, Newcastle-on-Tyne.
1895. †GILCHRIST, J. D. F., M.A., Ph.D., B.Sc., F.L.S. Marine Biologist's Office, Department of Agriculture, Cape Town.
1896. \*GILCHRIST, PERCY C., F.R.S., M.Inst.C.E. Reform Club, Pall Mall, S.W.
1911. †Gill, Rev. H. V., S.J. Milltown Park, Clonskea, Co. Dublin.
1902. †Gill, James F. 72 Strand-road, Bootle, Liverpool.
1908. †Gill, T. P. Department of Agriculture and Technical Instruction for Ireland, Dublin.
1913. \*Gillett, Joseph A., B.A. Woodgreen, Banbury.
1913. †Gillmor, R. E. 57 Victoria-street, S.W.
1892. \*Gilmour, Matthew A. B., F.Z.S. Saffronhall House, Windmill-road, Hamilton, N.B.
1907. †Gilmour, S. C. 25 Cumberland-road, Acton, W.
1913. §Gilson, R. Cary, M.A. King Edward's School, Birmingham.
1913. †Gimingham, C. T., F.I.C. Research Station, Long Ashton, Bristol.
1893. \*Gimingham, Edward. Croyland, Clapton Common, N.E.
1904. †GINN, S. R., D.L. (Local Sec. 1904.) Brookfield, Trumpington-road, Cambridge.
1884. †Girdwood, G. P., M.D. 615 University-street, Montreal, Canada.
1886. \*Gisborne, Hartley, M.Can.S.C.E. Yoxall, Rural Route No. 1—Ladysmith, British Columbia, Canada.

Year of  
Election.

1883. \*Gladstone, Miss. 19 Chepstow-villas, Bayswater, W.  
 1871. \*GLAISHER, J. W. L., M.A., Sc.D., F.R.S., F.R.A.S. (Pres. A, 1890 ;  
 Council, 1878-86.) Trinity College, Cambridge.  
 1881. \*GLAZEBROOK, R. T., C.B., M.A., Sc.D., F.R.S. (Pres. A, 1893 ;  
 Council, 1890-94, 1905-11), Director of the National Physical  
 Laboratory. Bushy House, Teddington, Middlesex.  
 1881. \*Gleadow, Frederic. 38 Ladbroke-grove, W.  
 1915. †Glover, James. Lowton House, Lowton, Lancashire.  
 1915. §Godlee, Francis. 8 Minshall-street, Manchester.  
 1878. \*Godlee, J. Lister. Wakes Colne Place, Essex.  
 1880. †GODMAN, F. DU CANE, D.C.L., F.R.S., F.L.S., F.G.S. 45 Pont-  
 street, S.W.  
 1879. †GODWIN-AUSTEN, Lieut.-Colonel H. H., F.R.S., F.R.G.S., F.Z.S.  
 (Pres. E, 1883.) Nore, Godalming.  
 1908. \*GOLD, ERNEST, M.A. 8 Hurst Close, Bigwood-road, Hampstead  
 Garden Suburb, N.W.  
 1914. †Gold, Mrs. 8 Hurst Close, Bigwood-road, Hampstead Garden  
 Suburb, N.W.  
 1906. †GOLDIE, Right Hon. Sir GEORGE D. T., K.C.M.G., D.C.L., F.R.S.  
 (Pres. E, 1906 ; Council, 1906-07.) Naval and Military Club,  
 94 Piccadilly, W.  
 1910. †Golding, John, F.I.C. University College, Reading.  
 1913. †Golding, Mrs. University College, Reading.  
 1890. \*GONNER, F. C. K., M.A. (Pres. F, 1897, 1914), Professor of Economic  
 Science in the University of Liverpool. Undercliff,  
 West Kirby, Cheshire.  
 1909. †Goodair, Thomas. 303 Kennedy-street, Winnipeg, Canada.  
 1912. §Goodman, Sydney C. N., B.A. 103 Drakefield-road, Tooting Bec  
 Common, S.W.  
 1907. §GOODRICH, E. S., M.A., F.R.S., F.L.S. 53 Banbury-road, Oxford.  
 1908. †Goodrich, Mrs., D.Sc. 53 Banbury-road, Oxford.  
 1884. \*Goodridge, Richard E. W. P.O. Box 36, Coleraine, Minnesota,  
 U.S.A.  
 1904. †Goodwin, Professor L. F., Ph.D. Queen's University, Kingston,  
 Canada.  
 1884. †Goodwin, Professor W. L. Queen's University, Kingston, Ontario,  
 Canada.  
 1909. †Gordon, Rev. Charles W. 567 Broadway, Winnipeg, Canada.  
 1909. †Gordon, J. T. 147 Hargrave-street, Winnipeg, Canada.  
 1909. †Gordon, Mrs. J. T. 147 Hargrave-street, Winnipeg, Canada.  
 1911. \*Gordon, J. W. 113 Broadhurst-gardens, Hampstead, N.W.  
 1871. \*Gordon, Joseph Gordon, F.C.S. Queen Anne's-mansions, West-  
 minster, S.W.  
 1893. †Gordon, Mrs. M. M. Ogilvie, D.Sc. 1 Rubislaw-terrace, Aberdeen.  
 1910. \*Gordon, Vivian. Avonside Engine Works, Fishponds, Bristol.  
 1912. §Gordon, W. T. Geological Department, King's College, Strand,  
 W.C.  
 1881. †Gough, Rev. Thomas, B.Sc. King Edward's School, Retford.  
 1901. †GOURLAY, ROBERT. Glasgow.  
 1876. †Gow, Robert. Cairndowan, Dowanhill-gardens, Glasgow.  
 1883. †Gow, Mrs. Cairndowan, Dowanhill-gardens, Glasgow.  
 1873. †Goyder, Dr. D. Marley House, 88 Great Horton-road, Bradford,  
 Yorkshire.  
 1908. \*GRABHAM, G. W., M.A., F.G.S. P.O. Box 178, Khartoum, Sudan.  
 1886. †Grabham, Michael C., M.D. Madeira.  
 1909. †GRACE, J. H., M.A., F.R.S. Peterhouse, Cambridge.  
 1909. †Graham, Herbert W. 329 Kennedy-street, Winnipeg, Canada.

Year of  
Election.

1902. \*Graham, William, M.D. Purdysburn House, Belfast.  
 1914. †Graham, Mrs. Purdysburn House, Belfast.  
 1875. †GRAHAME, JAMES. (Local Sec. 1876.) Care of Messrs. Grahame, Crums, & Connal, 34 West George-street, Glasgow.  
 1904. §Gramont, Comte Arnaud de, D.Sc., Memb. de l'Institut de Franco, 179 rue de l'Université, Paris.  
 1896. †Grant, Sir James, K.C.M.G. Ottawa, Canada.  
 1914. †GRANT, KERR, M.Sc., Professor of Physics in the University of Adelaide, South Australia.  
 1908. \*Grant, Professor W. L. Queen's University, Kingston, Ontario.  
 1914. †Grasby, W. C. Care of G. J. W. Grasby, Esq., Grenfell-street, Adelaide, South Australia.  
 1890. †GRAY, ANDREW, M.A., LL.D., F.R.S., F.R.S.E., Professor of Natural Philosophy in the University of Glasgow.  
 1864. \*Gray, Rev. Canon Charles. West Retford Rectory, Retford.  
 1881. †Gray, Edwin, LL.B. Minster-yard, York.  
 1903. §Gray, Ernest, M.A. 104 Tulse-hill, S.W.  
 1904. †GRAY, Rev. H. B., D.D. (Pres. L, 1909). 91 Warwick-road, Ealing, W.  
 1892. \*Gray, James Hunter, M.A., B.Sc. 3 Crown Office-row, Temple, E.C.  
 1887. †Gray, Joseph W., F.G.S. 6 Richmond Park-crescent, Bournemouth.  
 1901. †Gray, R. Whytlaw. University College, W.C.  
 \*GRAY, Colonel WILLIAM. Farley Hall, near Reading.  
 1866. §Greaves, Charles Augustus, M.B., LL.B. 84 Friar-gate, Derby.  
 1910. †Greaves, R. H., B.Sc. 12 St. John's-crescent, Cardiff.  
 1904. \*Green, Professor A. G., M.Sc., F.R.S., Municipal School of Technology, Manchester.  
 1904. §Green, F. W. 5 Wordsworth-grove, Cambridge.  
 1914. †Green, Heber, D.Sc. The University, Melbourne.  
 1906. \*Green, J. A., M.A., Professor of Education in the University of Sheffield.  
 1908. †Green, Rev. William Spotswood, C.B., F.R.G.S. 5 Cowper-villas, Cowper-road, Dublin.  
 1916. §Greener, T. Y. Urpeth Lodge, Beamish, S.O., Co. Durham.  
 1909. †Greenfield, Joseph. P.O. Box 2935, Winnipeg, Canada.  
 1882. †GREENHILL, Sir A. G., M.A., F.R.S. 1 Staple Inn, W.C.  
 1905. †Greenhill, William. 6A George-street, Edinburgh.  
 1915. §Greenhow, J. H. 46 Princess-street, Manchester.  
 1913. \*Greenland, Miss Lucy Maud. St. Hilda's, Hornsea, East Yorkshire.  
 1898. \*GREENLY, EDWARD, F.G.S. Achnashean, near Bangor, North Wales.  
 1906. †Greenwood, Sir Hamar, Bart., M.P. National Liberal Club, Whitehall-place, S.W.  
 1915. §Greenwood, William. 35 Belgrave-road, Oldham.  
 1915. †Greg, Henry P. Lode Hill, Styal.  
 1894. \*GREGORY, J. WALTER, D.Sc., F.R.S., F.G.S. (Pres. C, 1907), Professor of Geology in the University of Glasgow.  
 1896. \*GREGORY, Professor R. A., F.R.A.S. (Council, 1916- ) 17 Grosvenor-road, Westminster, S.W.  
 1904. \*GREGORY, R. P., M.A. St. John's College, Cambridge.  
 1914. †Gregory, Miss U. J. The University, Glasgow.  
 1914. †Grew, Mrs. 30 Cheyne-row, S.W.  
 1916. §GREY, Right Hon. Earl, G.C.B., G.C.V.O. Howick, Lesbury.  
 1894. \*Griffith, C. L. T., Assoc.M.Inst.C.E. Gayton Corner, Harrow.  
 1908. §Griffith, Sir John P., M.Inst.C.E. Rathmines Castle, Rathmines, Dublin.

Year of  
Election.

1884. †GRIFFITHS, E. H., M.A., D.Sc., F.R.S. (Pres. A, 1906; Pres. L, 1913; Council, 1911- ), Principal of University College, Cardiff.
1884. †Griffiths, Mrs. University College, Cardiff.
1903. †Griffiths, Thomas P., J.P. 101 Manchester-road, Southport.
1888. \*Grimshaw, James Walter, M.Inst.C.E. St. Stephen's Club, Westminster, S.W.
1914. †Grinley, Frank. Wandella, Gale-street, Woolwich, N.S.W.
1911. †Grogan, Ewart S. *Camp Hill, near Newcastle, Staffs.*
1894. †GROOM, Professor P., M.A., F.L.S. North Park, Gerrard's Cross, Bucks.
1894. †Groom, T. T., M.A., D.Sc., F.G.S., Professor of Geology in the University of Birmingham.
1896. †Grossmann, Dr. Karl. 70 Rodney-street, Liverpool.
1913. †Grove, W. B., M.A. 45 Duchess-road, Edgbaston, Birmingham.
1869. †GRUBB, Sir HOWARD, F.R.S., F.R.A.S. Aberfoyle, Rathgar, Dublin.
1913. §Gruchy, G. F. B. de. Manoir de Noirmont, St. Aubin, Jersey.
1897. †Grünbaum, A. S., M.A., M.D. School of Medicine, Leeds.
1910. †Grundy, James. Ruislip, Teignmouth-road, Cricklewood, N.W.
1913. †Guest, James J. 11 St. Mark's-road, Leamington.
1915. §Guilleband, Claude W. St. John's College, Cambridge.
1887. †GUILLEMARD, F. H. H., M.A., M.D. The Mill House, Trumpington, Cambridge.
1905. \*Gunn, Donald. Royal Societies Club, St. James's-street, S.W.
1909. †Gunne, J. R., M.D. Kenora, Ontario, Canada.
1909. †Gunne, W. J., M.D. Kenora, Ontario, Canada.
1894. †Günther, R. T. Magdalen College, Oxford.
1880. §Guppy, John J. Ivy-place, High-street, Swansea.
1916. §Gurney, Miss L. Mary. The Grove, Jesmond, Newcastle-upon-Tyne.
1902. \*Gurney, Robert. Ingham Old Hall, Stalham, Norfolk.
1904. \*Gurney, Sir Eustace. Sprowston Hall, Norwich.
1914. †Guthrie, Mrs. Blanche. 184A Ladbroke-grove, W.
1906. \*GWYNNE-VAUGHAN, MRS. HELEN C. I., D.Sc., F.L.S. 93 Bedford Court-mansions, W.C.
1905. †Hacker, Rev. W. J. Idutywa, Transkei, South Africa.
1908. \*Hackett, Felix E. Royal College of Science, Dublin.
1916. §Hacking, Thomas. 33 Bowling Green-street, Leicester.
1881. \*HADDON, ALFRED CORT, M.A., Sc.D., F.R.S., F.Z.S. (Pres. H, 1902-1905; Council, 1902-08, 1910- ) 3 Cranmer-road, Cambridge.
1914. †Haddon, Mrs. 3 Cranmer-road, Cambridge.
1911. \*Haddon, Miss Kathleen. 3 Cranmer-road, Cambridge.
1888. \*Hadfield, Sir Robert, D.Met., D.Sc., F.R.S., M.Inst.C.E. 22 Carlton House-terrace, S.W.
1913. †Hadley, H. E., B.Sc. School of Science, Kidderminster.
1915. §HADOW, W. H., Principal of Armstrong College, Newcastle-on-Tyne.
1905. †Hahn, Professor P. H., M.A., Ph.D. York House, Gardens, Cape Town.
1911. †Haigh, B. P., B.Sc. James Watt Engineering Laboratory, The University, Glasgow.
1906. †Hake, George W. Oxford, Ohio, U.S.A.
1894. †HALDANE, JOHN SCOTT, M.A., M.D., F.R.S. (Pres. I, 1908.) Cherwell, Oxford.

Year of  
Election.

1911. §Halket, Miss A. C. Waverley House, 135 East India-road, E.  
 1899. †HALL, A. D., M.A., F.R.S. (Pres. M, 1914; Council, 1908-15.)  
 Development Commission, 6A Dean's-yard, S.W.  
 1914. †Hall, Mrs. A. D. Ewhurst, Mostyn-road, Merton.  
 1909. †Hall, Archibald A., M.Sc., Ph.D. Armstrong College, Newcastle-  
 on-Tyne.  
 1914. †Hall, Dr. Cuthbert. Glenrowan, Parramatta, Sydney.  
 1903. †HALL, E. MARSHALL, K.C. 75 *Cambridge-terrace*, W.  
 1879. \*Hall, Ebenezer. Abbeydale Park, near Sheffield.  
 1883. \*Hall, Miss Emily. 63 Belmont-street, Southport.  
 1854. \*HALL, HUGH FERGIE, F.G.S. Cissbury Court, West Worthing,  
 Sussex.  
 1884. †Hall, Thomas Proctor, M.D. 1301 Davie-street, Vancouver, B.C.,  
 Canada.  
 1908. \*Hall, Wilfred, Assoc.M.Inst.C.E. 9 Prior's-terrace, Tynemouth,  
 Northumberland.  
 1913. †Hall-Edwards, J. The Elms, 112 Gough-road, Edgbaston, Bir-  
 mingham.  
 1891. \*Hallett, George. Oak Cottage, West Malvern.  
 1873. \*HALLETT, T. G. P., M.A. Claverton Lodge, Bath.  
 1888. §HALLIBURTON, W. D., M.D., LL.D., F.R.S. (Pres. I, 1202; Council,  
 1897-1903, 1911- ), Professor of Physiology in King's College,  
 London. Church Cottage, 17 Marylebone-road, N.W.  
 1905. †Halliburton, Mrs. Church Cottage, 17 Marylebone-road, N.W.  
 1904. \*Hallidie, A. H. S. Avondale, Chesterfield-road, Eastbourne.  
 1916. §Hallsworth, H. M., M.A., Professor of Economics in the Armstrong  
 College, Newcastle-on-Tyne.  
 1886. †Hambleton, G. W. 109 Ramsden-road, S.W.  
 1908. \*Hamel, Egbert Alexander de. Middleton Hall, Tamworth.  
 1883. \*Hamel, Egbert D. de. Middleton Hall, Tamworth.  
 1915. †Hamer, J. St. James'-buildings, Oxford-street, Manchester.  
 1906. †Hamill, John Molyneux, M.A., M.B. 14 South-parade, Chiswick,  
 1906. †Hamilton, Charles I. 88 *Twyford-avenue*, Acton.  
 1909. †Hamilton, F. C. Bank of Hamilton-chambers, Winnipeg,  
 Canada.  
 1902. †HAMILTON, Rev. T., D.D. Queen's College, Belfast.  
 1909. †Hamilton, T. Glen, M.D. 264 Renton-avenue, Winnipeg,  
 Canada.  
 1899. \*Hanbury, Daniel. Lenqua da Cà, Alassio, Italy.  
 1878. †Hance, E. M. Care of J. Hope Smith, Esq., 3 Leman-street, E.C.  
 1905. \*Hancock, Strangman. Kennel Holt, Cranbrook, Kent.  
 1912. †Hankin, G. T. 150 Whitehall-court, S.W.  
 1911. †Hann, H. F. 139 Victoria-road North, Southsea.  
 1906. §Hanson, David. Salterlee, Halifax, Yorkshire.  
 1904. §Hanson, E. K. Woodthorpe, Royston Park-road, Hatch End,  
 Middlesex.  
 1914. †Happell, Mrs. Care of Miss E. M. Bunday, Molesworth Street,  
 North Adelaide, South Australia.  
 1859. \*HARCOURT, A. G. VERNON, M.A., D.C.L., LL.D., D.Sc., F.R.S.,  
 V.P.C.S. (GEN. SEC. 1883-97; Pres. B, 1875; Council,  
 1881-83.) St. Clare, Ryde, Isle of Wight.  
 1909. †Harcourt, George. Department of Agriculture, Edmonton, Alberta,  
 Canada.  
 1886. \*Hardcastle, Colonel Basil W., F.S.S. 12 Gainsborough-gardens,  
 Hampstead, N.W.  
 1902. \*HARDCASTLE, Miss FRANCES. 3 Osborne-terrace, Newcastle-on-  
 Tyne.

Year of  
Electio n.

1903. \*Hardcastle, J. Alfred. The Dial House, Crowthorne, Berkshire.  
 1892. \*HARDEN, ARTHUR, Ph.D., D.Sc., F.R.S. Lister Institute of Preventive Medicine, Chelsea-gardens, Grosvenor-road, S.W.  
 1877. †Harding, Stephen. Bower Ashton, Clifton, Bristol.  
 1894. †Hardman, S. C. 120 Lord-street, Southport.  
 1913. †Hardy, George Francis. 30 Edwardes-square, Kensington, W.  
 1909. †HARDY, W. B., M.A., F.R.S. Gonville and Caius College, Cambridge.  
 1881. †Hargrove, William Wallace. St. Mary's, Bootham, York.  
 1890. \*HARKER, ALFRED, M.A., F.R.S., F.G.S. (Pres. C, 1911.) St. John's College, Cambridge.  
 1914. †Harker, Dr. George. The University, Sydney, N.S.W.  
 1896. †Harker, John Allen, D.Sc., F.R.S. National Physical Laboratory, Bushy House, Teddington, S.W.  
 1875. \*Harland, Rev. Albert Augustus, M.A., F.G.S., F.L.S., F.S.A. The Vicarage, Harefield, Middlesex.  
 1877. \*Harland, Henry Seaton. 8 Arundel-terrace, Brighton.  
 1883. \*Harley, Miss Clara. Rastrick, Cricketfield-road, Torquay.  
 1899. †Harman, Dr. N. Bishop, F.R.C.S. 108 Harley-street, W.  
 1913. †Harmar, Mrs. 102 Hagley-road, Birmingham.  
 1868. \*HARMER, F. W., F.G.S. Oakland House, Cringleford, Norwich.  
 1881. \*HARMER, SIDNEY F., M.A., Sc.D., F.R.S. (Pres. D, 1908; Council, 1916- ), Keeper of the Department of Zoology, British Museum (Natural History), Cromwell-road, S.W. 1A Thornton-hill, Wimbledon, S.W.  
 1912. \*Harper, Alan G., B.A. Magdalen College, Oxford.  
 1906. †Harper, J. B. 16 St. George's-place, York.  
 1913. †Harris, F. W. 132 and 134 Hurst-street, Birmingham.  
 1842. †Harris, G. W. Millicent, South Australia.  
 1909. †Harris, J. W. Civic Offices, Winnipeg.  
 1903. †Harris, Robert, M.B. Queen's-road, Southport.  
 1904. \*Harrison, Frank L., B.A., B.Sc. Grammar School Cottage, St. John's, Antigua, B.W.I.  
 1904. †HARRISON, H. SPENCER. The Horniman Museum, Forest Hill, S.E.  
 1892. †HARRISON, JOHN. (Local Sec. 1892.) Rockville, Napier-road, Edinburgh.  
 1915. †Harrison, Launcelot. Quick Laboratory, Cambridge.  
 1892. †Harrison, Rev. S. N. Ramsey, Isle of Man.  
 1901. \*Harrison, W. E. 17 Soho-road, Handsworth, Staffordshire.  
 1911. †Harrison-Smith, F., C.B. H.M. Dockyard, Portsmouth.  
 1885. †HART, Colonel C. J. (Local Sec. 1886.) Highfield Gate, Edgbaston, Birmingham.  
 1909. †Hart, John A. 120 Emily-street, Winnipeg, Canada.  
 1876. \*Hart, Thomas. Brooklands, Blackburn.  
 1903. \*Hart, Thomas Clifford. Brooklands, Blackburn.  
 1907. §Hart, W. E. Kilderry, near Londonderry.  
 1911. †Hart-Synnot, Ronald V. O. University College, Reading.  
 1893. \*HARTLAND, E. SIDNEY, F.S.A. (Pres. H, 1906; Council, 1906-13.) Highgarth, Gloucester.  
 1905. †Hartland, Miss. Highgarth, Gloucester.  
 1886. \*HARTOG, Professor M. M., D.Sc. University College, Cork.  
 1887. †HARTOG, P. J., B.Sc. University of London, South Kensington, S.W.  
 1862. \*Harwood, John. Woodside Mills, Bolton-le-Moors.  
 1893. §Haslam, Lewis. 8 Wilton-crescent, S.W.  
 1911. \*Hassé, H. R. The University, Manchester.  
 1903. \*Hastie, Miss J. A. Care of Messrs. Street & Co., 30 Cornhill, E.C.



Year of  
Election.

1904. †HASTINGS, G. 23 Oak-lane, Bradford, Yorkshire.  
 1875. \*HASTINGS, G. W. (Pres. F, 1875.) Holly Bank, Braeknell, Berks.  
 1903. †Hastings, W. G. W. 2 Halsey-street, Cadogan-gardons, S.W.  
 1889. †HATCH, F. H., Ph.D., F.G.S. 15 Cope-hill, Wimbledon, S.W.  
 1903. †Hathaway, Herbert G. 45 High-street, Bridgnorth, Salop.  
 1904. \*Haughton, W. T. H. The Highlands, Great Barford, St. Neots.  
 1908. §HAVELOCK, T. H., M.A., D.Sc., F.R.S., Professor of Applied  
 Mathematics in Armstrong College, Newcastle-on-Tyne.  
 Rockliffe, Gosforth, Newcastle-on-Tyne.  
 1904. †Havilland, Hugh de. Eton College, Windsor.  
 1917. §Hawkes, Mrs. O. A. Merritt, M.Sc., B.Sc. 405 Hagley-road,  
 Birmingham.  
 1887. \*Hawkins, William. Earliston House, Broughton Park, Manchester.  
 1864. \*HAWKSHAW, JOHN CLARKE, M.A., M.Inst.C.E., F.G.S. (Council,  
 1881-87.) 22 Down-street, W.  
 1897. §HAWKSLEY, CHARLES, M.Inst.C.E., F.G.S. (Pres. G, 1903; Council,  
 1902-09.) Caxton House (West Block), Westminster, S.W.  
 1887. \*Haworth, Jesse. Woodside, Bowdon, Cheshire.  
 1913. †Haworth, John F. Withens, Barker-road, Sutton Coldfield.  
 1916. §Haworth, John. The Employers' Parliamentary Association, 15  
 Cross-street, Manchester.  
 1913. †Haworth, Mrs. Withens, Barker-road, Sutton Coldfield.  
 1885. \*HAYCRAFT, JOHN BERRY, M.D., B.Sc., F.R.S.E., Professor of  
 Physiology in University College, Cardiff.  
 1900. §Hayden, H. H., B.A., F.R.S., F.G.S. Geological Survey, Calcutta,  
 India.  
 1903. \*Haydock, Arthur. 10 Lord Derby-street, Blackburn.  
 1913. §Hayward, Miss. 7 Abbotsford-road, Galashiels, N.B.  
 1903. †Hayward, Joseph William, M.Sc. Keldon, St. Marychurch,  
 Torquay.  
 1896. \*Haywood, Colonel A. G. 8 Carson-road, West Dulwich, S.E.  
 1883. †Heape, Joseph R. Glebe House, Rochdale.  
 1882. \*Heape, Walter, M.A., F.R.S. 10 King's Bench-walk, Temple, E.C.  
 1909. †Heard, Mrs. Sophie, M.B., Ch.B. Carisbrooke, Fareham, Hants.  
 1908. §Heath, J. St. George, B.A. The Warden's Lodge, Toynbee Hall,  
 Commercial-street, E.  
 1902. †Heath, J. W. Royal Institution, Albemarle-street, W.  
 1898. †HEATH, R. S., M.A., D.Sc., Vice-Principal and Professor of Mathe-  
 matics in the University of Birmingham.  
 1909. †Heathcote, F. C. C. Broadway, Winnipeg, Canada.  
 1883. †Heaton, Charles. Marlborough House, Hesketh Park, Southport.  
 1913. §HEATON, HOWARD. (Local Sec., 1913.) Wayside, Lode-lane,  
 Solihull, Birmingham.  
 1892. \*HEATON, WILLIAM H., M.A. (Local Sec., 1893), Principal of and  
 Professor of Physics in University College, Nottingham.  
 1889. \*Heavyside, Arthur West, I.S.O. 12 Tring-avenue, Ealing, W.  
 1888. \*HEAWOOD, EDWARD, M.A. Briarfield, Church-hill, Merstham,  
 Surrey.  
 1888. \*Heawood, Percy J., Professor of Mathematics in Durham Univer-  
 sity. High Close, Hollinside-lane, Durham.  
 1887. \*HEDGES, KILLINGWORTH, M.Inst.C.E. 10 Cranley-place, South  
 Kensington, S.W.  
 1881. \*HELE-SHAW, H. S., D.Sc., LL.D., F.R.S., M.Inst.C.E. (Pres. G,  
 1915.) 64 Victoria-street, S.W.  
 1901. \*HELLER, W. M., B.Sc. Education Office, Marlborough-street,  
 Dublin.  
 1911. †Hellyer, Francis E. Farlington House, Havant, Hants.

Year of  
Election.

1887. †Hembry, Frederick William, F.R.M.S. City-chambers, 2 St. Nicholas-street, Bristol.
1908. †Hemmy, Professor A. S. Government College, Lahore.
1899. †Hemsalech, G. A., D.Sc. The Owens College, Manchester.
1905. \*Henderson, Andrew. 17 Belhaven-terrace, Glasgow.
1905. \*Henderson, Miss Catharine. 17 Belhaven-terrace, Glasgow.
1891. \*HENDERSON, G. G., M.A., D.Sc., LL.D., F.R.S., F.I.C. (Pres. B, 1916), Professor of Chemistry in the Royal Technical College, Glasgow.
1905. §Henderson, Mrs. 7 Marlborough-drive, Kelvinside, Glasgow.
1907. †Henderson, H. F. Felday, Morland-avenue, Leicester.
1906. †Henderson, J. B., D.Sc., Professor of Applied Mechanics in the Royal Naval College, Greenwich, S.E.
1909. †Henderson, Veylien E. Medical Building, The University, Toronto, Canada.
1916. §Henderson, W. F. Moorfield, Claremont, Newcastle-on-Tyne.
1880. \*Henderson, Admiral W. H., R.N. 3 Onslow Houses, S.W.
1911. †Henderson, William Dawson. The University, Bristol.
1904. \*Hendrick, James, B.Sc., F.I.C., Professor of Agriculture in Marischal College, Aberdeen.
1910. †Heney, T. W. Sydney, New South Wales.
1910. \*HENRICI, Major E. O., R.E., A.Inst.C.E. Ordnance Survey Office, Southampton.
1873. \*HENRICI, OLAUS M. F. E., Ph.D., F.R.S. (Pres. A, 1883 ; Council, 1883-89.) Hiltingbury Lodge, Chandler's Ford, Hants.
1910. †Henry, Hubert, M.D. 304 Glossop-road, Sheffield.
1906. †Henry, Dr. T. A. Imperial Institute, S.W.
1909. \*Henshall, Robert. Sunnyside, Latchford, Warrington.
1916. §Henson, Very Rev. Dean H. H., D.D. The Deanery, Durham.
1892. †HEPBURN, DAVID, M.D., F.R.S.E., Professor of Anatomy in University College, Cardiff.
1904. †Hepworth, Commander M. W. C., C.B., R.N.R. Meteorological Office, South Kensington, S.W.
1909. †Herbinson, William. 376 Ellice-avenue, Winnipeg, Canada.
1914. \*Herdman, Miss C. Croxteth Lodge, Sefton Park, Liverpool.
1902. †Herdman, G. W., B.Sc., Assoc.M.Inst.C.E. Irrigation and Water Supply Department, Pretoria.
1887. \*HERDMAN, WILLIAM A., D.Sc., LL.D., F.R.S., F.R.S.E., F.L.S. (GENERAL SECRETARY, 1903- ; Pres. D, 1895 ; Council, 1894-1900 ; Local Sec. 1896), Professor of Natural History in the University of Liverpool. Croxteth Lodge, Sefton Park, Liverpool.
1893. \*Herdman, Mrs. Croxteth Lodge, Sefton Park, Liverpool.
1909. †Herdt, Professor L. A. McGill University, Montreal, Canada.
1875. †HEREFORD, The Right Rev. JOHN PERCIVAL, D.D., LL.D., Lord Bishop of. (Pres. L, 1904.) The Palace, Hereford.
1915. §Herford, Miss Caroline. 8 Oak-drive, Fallowfield, Manchester.
1912. †Heron, David, D.Sc. Galton Eugenics Laboratory, University College, W.C.
1912. \*HERON-ALLEN, EDWARD, F.L.S., F.G.S. 33 Hamilton-terrace, N.W. ; and Large Acres, Selsey Bill, Sussex.
1908. \*Herring, Percy T., M.D., Professor of Physiology in the University, St. Andrews, N.B.
1874. §HERSCHEL, Colonel JOHN, R.E., F.R.S., F.R.A.S. Observatory House, Slough, Bucks.
1900. \*Herschel, Rev. J. C. W. Braywood Vicarage, Winkfield, Windsor.
1913. †Hersey, Mayo Dyer, A.M. Bureau of Standards, Washington, U.S.A.

Year of  
Election.

1905. †Hervey, Miss Mary F. S. 22 Morpeth-mansions, S.W.  
 1903. \*HESKETH, CHARLES H. FLEETWOOD, M.A. Stocken Hall, Stretton, Oakham.  
 1895. §Hesketh, James. 5 Scarisbrick Avenue, Southport.  
 1913. §Hett, Miss Mary L. 53 Fordwych-road, West Hampstead, N.W.  
 1894. †HEWETSON, G. H. (Local Sec. 1896.) 39 Henley-road, Ipswich.  
 1915. †Hewison, William. Winfield, St. George's-crescent, Pendleton.  
 1908. †Hewitt, Dr. C. Gordon. Central Experimental Farm, Ottawa.  
 1896. †Hewitt, David Basil, M.D. Oakleigh, Northwich, Cheshire.  
 1903. †Hewitt, E. G. W. 87 Princess-road, Moss Side, Manchester.  
 1903. †Hewitt, John Theodore, M.A., D.Sc., Ph.D., F.R.S. Clifford House, Staines-road, Bedfont, Middlesex.  
 1909. †Hewitt, W., B.Sc. 16 Clarence-road, Birkenhead.  
 1882. \*HEYCOCK, CHARLES T., M.A., F.R.S. 3 St. Peter's-terrace, Cambridge.  
 1883. †Heyes, Rev. John Frederick, M.A., F.R.G.S. St. Barnabas Vicarage, Bolton.  
 1866. \*Heymann, Albert. West Bridgford, Nottinghamshire.  
 1912. §Heywood, H. B., D.Sc. 40 Manor-way, Ruislip.  
 1912. †Hickling, George, D.Sc., F.G.S. The University, Manchester.  
 1877. §HICKS, W. M., M.A., D.Sc., F.R.S. (Pres. A, 1895), Professor of Physics in the University of Sheffield. Leamhurst, Ivy Park-road, Sheffield.  
 1886. †Hicks, Mrs. W. M. Leamhurst, Ivy Park-road, Sheffield.  
 1887. \*HICKSON, SYDNEY J., M.A., D.Sc., F.R.S. (Pres. D, 1903; Local Secretary, 1915), Professor of Zoology in Victoria University, Manchester.  
 1864. \*HIERN, W. P., M.A., F.R.S. The Castle, Barnstaple.  
 1914. †Higgins, J. M. Riversdale-road, Camberwell, Victoria.  
 1914. †Higgins, Mrs. J. M. Riversdale-road, Camberwell, Victoria.  
 1891. †HIGGS, HENRY, C.B., LL.B., F.S.S. (Pres. F, 1899; Council, 1904-06.) H.M. Treasury, Whitehall, S.W.  
 1909. †Higman, Ormond. Electrical Standards Laboratory, Ottawa.  
 1913. \*Higson, G. I., M.Sc. 11 Westbourne-road, Birkdale, Lancashire.  
 1907. †HILEY, E. V. (Local Sec. 1907.) Town Hall, Birmingham.  
 1911. \*Hiley, Wilfrid E. Danesfield, Boar's Hill, Oxford.  
 1885. \*HILL, ALEXANDER, M.A., M.D. Hartley University College, Southampton.  
 1903. \*HILL, ARTHUR W., M.A., F.L.S. Royal Gardens, Kew.  
 1906. †Hill, Charles A., M.A., M.B. 13 Rodney-street, Liverpool.  
 1881. \*HILL, Rev. Canon EDWIN, M.A. The Rectory, Ceckfield, Bury St. Edmunds.  
 1908. \*HILL, JAMES P., D.Sc., F.R.S., Professor of Zoology in University College, Gower-street, W.C.  
 1911. †HILL, LEONARD, M.B., F.R.S. (Pres. I, 1912.) Osborne House, Loughton, Essex.  
 1912. †Hill, M. D. Angelo's, Eton College, Windsor.  
 1886. †HILL, M. J. M., M.A., D.Sc., F.R.S., Professor of Pure Mathematics in University College, W.C.  
 1898. \*Hill, Thomas Sidney. Langford House, Langford, near Bristol.  
 1907. \*HILLS, Colonel E. H., C.M.G., R.E., F.R.S., F.R.G.S. (Pres. E, 1908.) 1 Campden-hill, W.  
 1911. \*Hills, William Frederick Waller. 32 Prince's-gardens, S.W.  
 1903. \*Hilton, Harold, D.Sc. 108 Alexandra-road, South Hampstead, N.W.  
 1903. \*HIND, WHEELTON, M.D., F.G.S. Roxeth House, Stoke-on-Trent.  
 1870. †HINDE, G. J., Ph.D., F.R.S., F.G.S. Ivythorn, Avondale-road, South Croydon, Surrey.

Year of  
Election.

1910. †Hindle, Edward, B.A., Ph.D., F.L.S. Quick Laboratories, Cambridge.
1883. \*Hindle, James Henry. 8 Cobham-street, Accrington.
1915. \*Hindley, R. T. The Green-way, Macclesfield.
1898. †Hinds, Henry. 57 Queen-street, Ramsgate.
1911. †Hinks, Arthur R., M.A., F.R.S., Sec. R.G.S. Royal Geographical Society, Kensington Gore, S.W.; and 17 St. Petersburg-place, W.
1903. \*Himmers, Edward. Glentwood, South Downs-drive, Hale, Cheshire.
1915. †Hitchcock, E. F. Toynbee Hall, Commercial-street, E.
1914. †Hoadley, C. A., M.Sc. Weenabah, Ballarat, Victoria.
1915. †Hoatson, John. 117 City-road, Edgbaston, Birmingham.
1899. †Hobday, Henry. Hazelwood, Crabble Hill, Dover.
1914. †Hobson, A. Kyme. Overseas Club, 266 Flinders-street, Melbourne.
1887. \*HOBSON, BERNARD, M.Sc., F.G.S. Thornton, Hallamgate-road, Sheffield.
1904. †HOBSON, ERNEST WILLIAM, Sc.D., F.R.S. (Pres. A, 1910), Sadleirian Professor of Pure Mathematics in the University of Cambridge, The Gables, Mount Pleasant, Cambridge.
1907. †Hobson, Mrs. Mary. 6 Hopefield-avenue, Belfast.
1913. †Hodges, Ven. Archdeacon George, M.A. Ely.
1916. \*Hodgkin, T. E., M.A. Old Ridley, Stocksfield, Northumberland.
1887. \*Hodgkinson, Alexander M.B., B.Sc. Bradshaigh, Lower Bourne, near Farnham, Surrey.
1880. †Hodgkinson, W. R. Eaton, Ph.D., F.R.S.E., F.G.S., Professor of Chemistry and Physics in the Royal Artillery College, Woolwich. 18 Glenluce-road, Blackheath, S.E.
1912. †Hodgson, Benjamin. The University, Bristol.
1905. †Hodgson, Ven. Archdeacon R. The Rectory, Wolverhampton.
1909. †Hodgson, R. T., M.A. Collegiate Institute, Brandon, Manitoba, Canada.
1898. †Hodgson, T. V. Municipal Museum and Art Gallery, Plymouth.
1904. \*Hodson, F., Ph.D. Bablake School, Coventry.
1907. †Hodson, Mrs. Bablake School, Coventry.
1915. †Hoffert, H. H., D.Sc. The Gables, Marple, Stockport.
1904. †HOGARTH, D. G., M.A. (Pres. H, 1907; Council, 1907-10.) 20 St. Giles's, Oxford.
1914. †Hogben, George, M.A., F.G.S. 9 Tinakori-road, Wellington, New Zealand.
1908. †Hogg, Right Hon. Jonathan. Stratford, Rathgar, Co. Dublin.
1911. †Holbrook, Colonel A. R. Warleigh, Grove-road South, Southsea.
1907. †Holden, Colonel Sir H. C. L., K.C.B., R.A., F.R.S. Gifford House, Blackheath, S.E.
1883. †Holden, John J. 73 Albert-road, Southport.
1887. \*Holder, Henry William, M.A. Beechmount, Arnside.
1913. †Holder, Sir John C., Bart. Pitmaston, Moor Green, Birmingham.
1900. †HOLDICH, Colonel Sir THOMAS H., K.C.M.G., K.C.I.E., C.B. (Pres. E, 1902.) 41 Courtfield-road, S.W.
1887. \*Holdsworth, C. J., J.P. Fernhill, Alderley Edge, Cheshire.
1904. †Holland, Charles E. 9 Downing-place, Cambridge.
1903. †Holland, J. L., B.A. 3 Primrose-hill, Northampton.
1896. †Holland, Mrs. Lowfields House, Hooton, Cheshire.
1898. †HOLLAND, Sir THOMAS H., K.C.I.E., F.R.S., F.G.S. (Pres. C, 1914), Professor of Geology in the Victoria University, Manchester.
1889. †Holländer, Bernard, M.D. 35A Welbeck-street, W.
1906. \*Hollingworth, Miss. Leithen, Newnham-road, Bedford.

Year of  
Election.

1916. \*Holmes, Arthur, B.Sc., F.G.S. Elmhurst, Langley-road, Merton Park, Surrey.
1883. \*Holmes, Mrs. Basil. 23 Corfton-road, Ealing, W.
1866. \*Holmes, Charles. 47 Wellington-road, Bush Hill Park.
1882. \*HOLMES, THOMAS VINCENT, F.G.S. 28 Croom's-hill, Greenwich, S.E.
1912. †Holmes-Smith, Edward, B.Sc. Royal Botanic Gardens, Edinburgh.
1903. \*HOLT, ALFRED, M.A., D.Sc. Dowsefield, Allerton, Liverpool.
1915. §HOLT, Alderman Sir E., Bart., J.P. Woodthorpe, Bury Old-road, Heaton Park, Manchester.
1875. \*Hood, John. Chesterton, Cirencester.
1904. §Hooke, Rev. D. Burford, D.D. 20 Cavendish-road, Henleaze, Bristol.
1908. \*Hooper, Frank Henry. Deepdene, Streatham Common, S.W.
1865. \*Hooper, John P. Deepdene, Streatham Common, S.W.
1877. \*Hooper, Rev. Samuel F., M.A. Lydlinch Rectory, Sturminster Newton, Dorset.
1904. †Hopewell-Smith, A., M.R.C.S. 37 Park-street, Grosvenor-square, S.W.
1905. \*Hopkins, Charles Hadley. Junior Constitutional Club, 101 Piccadilly, W.
1913. †HOPKINS, F. GOWLAND, M.A., D.Sc., M.B., F.R.S. (Pres. I, 1913). Trinity College, and Saxmeadham, Grange-road, Cambridge.
1901. \*HOPKINSON, BERTRAM, M.A., F.R.S., F.R.S.E., Professor of Mechanism and Applied Mechanics in the University of Cambridge. 10 Adams-road, Cambridge.
1884. \*HOPKINSON, CHARLES. (Local Sec. 1887.) The Limes, Didsbury, near Manchester.
1882. \*Hopkinson, Edward, M.A., D.Sc. Ferns, Alderley Edge, Cheshire.
1871. \*HOPKINSON, JOHN, Assoc.Inst.C.E., F.L.S., F.G.S., F.R.Met.Soc. Weetwood, Watford.
1905. †Hopkinson, Mrs. John. Ellerslie, Adams-road, Cambridge.
1898. \*Hornby, R., M.A. Haileybury College, Hertford.
1910. †Horne, Arthur S. Kerlegh, Cobham, Surrey.
1885. †HORNE, JOHN, LL.D., F.R.S., F.R.S.E., F.G.S. (Pres. C, 1901.) 20 Merchiston-gardens, Edinburgh.
1903. †Horne, William, F.G.S. Leyburn, Yorkshire.
1902. †Horner, John. Chelsea, Antrim-road, Belfast.
1905. \*Horsburgh, E. M., M.A., B.Sc., Lecturer in Technical Mathematics in the University of Edinburgh.
1887. †Horsfall, T. C. Swanscoe Park, near Macclesfield.
1908. †Horton, F. St. John's College, Cambridge.
1884. \*Hotblack, G. S. Brundall, Norwich.
1906. \*Hough, Miss Ethel M. Codsall Wood, near Wolverhampton.
1859. †Hough, Joseph, M.A., F.R.A.S. Codsall Wood, Wolverhampton.
1896. \*Hough, S. S., M.A., F.R.S., F.R.A.S., His Majesty's Astronomer at the Cape of Good Hope. Royal Observatory, Cape Town.
1905. §Houghting, A. G. L. Glenelg, Musgrave-road, Durban, Natal.
1886. †Houghton, F. T. S., M.A., F.G.S. 188 Hagley-road, Birmingham.
1914. †Houghton, T. H., M.Inst.C.E. 63 Pitt-street, Sydney, N.S.W.
1903. †Houston, David, F.L.S. Royal College of Science, Dublin.
1893. †Howard, F. T., M.A., F.G.S. West Mount, Waverton, near Chester.
1904. \*Howard, Mrs. G. L. C. Agricultural Research Institute, Pusa, Bengal, India.
1887. \*Howard, S. S. 56 Albemarle-road, Beckenham, Kent.
1901. §Howarth, E., F.R.A.S. Public Museum, Weston Park, Sheffield.
1903. \*Howarth, James H., F.G.S. Holly Bank, Halifax.

Year of  
Election.

1907. †HOWARTH, O. J. R., M.A. (ASSISTANT SECRETARY.) 24 Lansdowne-crescent, W.
1914. †Howchin, Professor Walter. University of Adelaide, South Australia.
1911. \*Howe, Professor G. W. O., D.Sc. 22 Dorset-road, Merton Park, Surrey.
1905. †Howick, Dr. W. P.O. Box 503, Johannesburg.
1863. †HOWORTH, Sir H. H., K.C.I.E., D.C.L., F.R.S., F.S.A. 45 Lexham-gardens, W.
1887. §HOYLE, WILLIAM E., M.A., D.Sc. (Pres. D, 1907.) National Museum of Wales, City Hall, Cardiff.
1903. †Hübner, Julius. Ash Villa, Cheadle Hulme, Cheshire.
1913. †Huddart, Mrs. J. A. 2 Chatsworth-gardens, Eastbourne.
1898. †Hudson, Mrs. *Sunny Bank, Egerton, Huddersfield.*
1913. †Hughes Alfred, M.A., Professor of Education in the University of Birmingham. 29 George-road, Edgbaston, Birmingham.
1871. \*Hughes, George Pringle, J.P., F.R.G.S. Middleton Hall, Wooler, Northumberland.
1914. †Hughes, Herbert W. Adelaide Club, Adelaide, South Australia.
1868. †HUGHES, T. M'K., M.A., F.R.S., F.G.S. (Council, 1879-86), Woodwardian Professor of Geology in the University of Cambridge. Ravensworth, Brooklands-avenue, Cambridge.
1867. †HULL, EDWARD, M.A., LL.D., F.R.S., F.G.S. (Pres. C, 1874.) 14 Stanley-gardens, Notting Hill, W.
1903. †Hulton, Campbell G. Palace Hotel, Southport.
1905. †Hume, D. G. W. 55 Gladstone-street, Dundee, Natal.
1911. \*Hume, Dr. W. F. Helwan, Egypt.
1914. †Humphrey, G. D. Care of Messrs. Lane & Peters, Burrinjuck, New South Wales.
1904. \*Humphreys, Alexander C., Sc.D., LL.D., President of the Stevens Institute of Technology, Hoboken, New Jersey, U.S.A.
1907. §Humphries, Albert E. Coxe's Lock Mills, Weybridge.
1891. \*Hunt, Cecil Arthur. Southwood, Torquay.
1914. †Hunt, H. A. Weather Bureau, Melbourne.
1881. †Hunter, F. W. 16 Old Elvet, Durham.
1889. †Hunter, Mrs. F. W. 16 Old Elvet, Durham.
1916. §Hunter, G. B. The Willows, Jesmond, Newcastle-on-Tyne.
1916. §Hunter, Summers. 1 Manor-terrace, Tynemouth.
1909. †Hunter, W. J. H. 31 Lynedoch-street, Glasgow.
1901. \*Hunter, William. Evirallan, Stirling.
1903. †Hurst, Charles C., F.L.S. Burbage, Hinckley.
1861. \*Hurst, William John. Drumaness, Ballynahinch, Co. Down, Ireland.
1913. §Hutchins, Miss B. L. The Glade, Branch Hill, Hampstead Heath, N.W.
1914. §Hutchins, D. E. Medo House, Cobham, Kent.
1894. \*HUTCHINSON, A., M.A., Ph.D. (Local Sec. 1904.) Pembroke College, Cambridge.
1912. §Hutchinson, Dr. H. B. Rothamsted Experimental Station, Harpenden, Herts.
1903. §Hutchinson, Rev. H. N., M.A. 17 St. John's Wood Park, Finchley-road, N.W.
1864. \*Hutton, Darnton. 14 Cumberland-terrace, Regent's Park, N.W.
1887. \*Hutton, J. Arthur. The Woodlands, Alderley Edge, Cheshire.
1901. \*Hutton, R. S., D.Sc. West-street, Sheffield.
1871. \*Hyett, Francis A. Painswick House, Painswick, Stroud, Gloucestershire.
1900. \*Hyndman, H. H. Francis. 3 New-court, Lincoln's Inn, W.C.

Year of  
Election.

1908. †Idle, George. 43 Dawson-street, Dublin.  
 1883. †Idris, T. H. W. 110 Pratt-street, Camden Town, N.W.  
 1884. \*Iles, George. 5 Brunswick-street, Montreal, Canada.  
 1906. †Iliffe, J. W. Oak Tower, Uppertorpe, Sheffield.  
 1913. §Illing, Vincent Charles, B.A., F.G.S. The Chestnuts, Hartshill, Atherstone, Warwickshire.  
 1915. §Imms, A. D. West Wood, The Beeches, West Didsbury.  
 1885. §IM THURN, Sir EVERARD F., C.B., K.C.M.G. (Pres. H, 1914; Council, 1913- ) 39 Lexham-gardens, W.  
 1907. §Ingham, Charles B. Moira House, Eastbourne.  
 1901. †INGLIS, JOHN, LL.D. 4 Prince's-terrace, Dowanhill, Glasgow.  
 1905. †Innes, R. T. A., F.R.A.S. Union Observatory, Johannesburg.  
 1901. \*Ionides, Stephen A. 802 Equitable-building, Denver, Colorado.  
 1913. †Irvine, James, F.R.G.S. Richmond-buildings, Chapel-street, Liverpool.  
 1912. †Irvine, J. C., Ph.D., Professor of Chemistry in the University of St. Andrews.  
 1882. §IRVING, Rev. A., B.A., D.Sc. Hockerill Vicarage, Bishop's Stortford, Herts.  
 1908. †Irwin, Alderman John. 33 Rutland-square, Dublin.
1915. †Jack, A. J. 30 Amhurst-road, Withington, Manchester.  
 1914. †Jack, A. K., B.Sc. Agricultural College, Dookie, Victoria.  
 1909. †Jacks, Professor L. P. 28 Holywell, Oxford.  
 1883. \*Jackson, Professor A. H., B.Sc. 349 Collins-street, Melbourne, Australia.  
 1903. †Jackson, C. S. Royal Military Academy, Woolwich, S.E.  
 1915. †Jackson, E. J. W., B.A. The University, Edmund-street, Birmingham.  
 1874. \*Jackson, Frederick Arthur. Belmont, Somenos, Vancouver Island, B.C., Canada.  
 1883. \*Jackson, F. J. 35 Leyland-road, Southport.  
 1883. †Jackson, Mrs. F. J. 35 Leyland-road, Southport.  
 1899. †Jackson, Geoffrey A. 31 Harrington-gardens, Kensington, S.W.  
 1913. \*Jackson, H. Gordon, M.Sc. Mason College, Birmingham.  
 1906. \*Jackson, James Thomas, M.A. Engineering School, Trinity College, Dublin.  
 1898. \*Jackson, Sir John, K.C.V.O. 51 Victoria-street, S.W.  
 1887. §Jacobson, Nathaniel, J.P. Olive Mount, Cheetham Hill-road, Manchester.  
 1905. \*Jaffé, Arthur, M.A. New-court, Temple, E.C.  
 1874. \*Jaffé, John. Villa Jaffé, 38 Promenade des Anglais, Nice, France.  
 1906. †Jalland, W. H. Museum-street, York.  
 1891. \*James, Charles Russell. Albemarle Club, 37 Dover-street, W.  
 1916. §James, Rev. E. O., B.Litt., F.C.S. Alvescot Rectory, Clanfield, Oxon.  
 1904. †James, Thomas Campbell. University College, Aberystwyth.  
 1896. \*Jameson, H. Lyster, M.A., Ph.D. Board of Agriculture, 43 Parliament-street, S.W.  
 1889. \*JAPP, F. R., M.A., Ph.D., LL.D., F.R.S. (Pres. B, 1898.) 36 Twyford-avenue, West Acton, W.  
 1910. \*Japp, Henry, M.Inst.C.E. 59 Beaver Hall-hill, Montreal, Canada.  
 1896. \*Jarmay, Gustav. Hartford Lodge, Hartford, Cheshire.  
 1913. †Jarrard, W. J. The University, Sheffield.

Year of  
Election.

1903. †JARRATT, J. ERNEST. (Local Sec. 1903.) 22 Hesketh-road, Southport.
1904. \*Jeans, J. H., M.A., F.R.S. 8 Ormonde-gate, Chelsea, S.W.
1916. \*Jeffreys, Harold. St. John's College, Cambridge.
1912. §Jehu, T. J., M.A., M.D., Professor of Geology in the University of Edinburgh.
1908. \*Jenkin, Arthur Pearse, F.R.Met.Soc. Trewirgie, Redruth.
1909. \*Jenkins, Miss Emily Vaughan. 31 Antrim-mansions, South Hampstead, N.W.
1903. †Jenkinson, J. W. The Museum, Oxford.
1904. †Jenkinson, W. W. 6 Moorgate-street, E.C.
1893. †Jennings, G. E. Ashleigh, Ashleigh-road, Leicester.
1889. †Jevons, F. B., M.A. Hatfield Hall, Durham.
1900. \*Jevons, H. Stanley, M.A., B.Sc. 3 Pembroke-terrace, Cardiff.
1907. \*Jevons, Miss H. W. 17 Tredegar-square, Bow, E.
1905. §Jeyes, Miss Gertrude, B.A. Berrymead, 6 Lichfield-road, Kew Gardens.
1914. †Jobbins, G. G. Geelong Club, Geelong, Victoria.
1909. \*Johns, Cosmo, F.G.S., M.I.M.E. Burngrove, Pitsmoor-road, Sheffield.
1909. †Johnson, C. Kelsall, F.R.G.S. *The Glen, Sidmouth, Devon.*
1890. \*JOHNSON, THOMAS, D.Sc., F.L.S., Professor of Botany in the Royal College of Science, Dublin.
1902. \*Johnson, Rev. W., B.A., B.Sc. Wath Rectory, Melmerby S.O., Yorkshire.
1898. \*Johnson, W. Claude, M.Inst.C.E. Broadstone, Coleman's Hatch, Sussex.
1899. †JOHNSTON, Colonel Sir DUNCAN A., K.C.M.G., C.B., R.E., F.R.G.S. (Pres. E, 1909.) 8 Lansdowne-crescent, Edinburgh.
1883. †JOHNSTON, Sir H. H., G.C.M.G., K.C.B., F.R.G.S. St. John's Priory, Poling, near Arundel.
1913. †Johnston, James. Oak Bank-avenue, Manchester.
1909. \*Johnston, J. Weir, M.A. 129 Anglesea-road, Dublin.
1913. †Johnston, Dr. S. J. Department of Biology, The University, Sydney, N.S.W.
1908. †Johnston, Swift Paine. 1 Hume-street, Dublin.
1884. \*Johnston, W. H. County Offices, Preston, Lancashire.
1909. §JOLLY, Professor W. A., M.B., D.Sc. South African College, Cape Town.
1888. †JOLY, JOHN, M.A., D.Sc., F.R.S., F.G.S. (Pres. C, 1908), Professor of Geology and Mineralogy in the University of Dublin. Geological Department, Trinity College, Dublin.
1887. †Jones, D. E., B.Sc. Eryl Dag, Radyr, Cardiff.
1913. \*Jones, Daniel, M.A., Lecturer on Phonetics at University College, London, W.C.
1904. †Jones, Miss E. E. Constance. Girton College, Cambridge.
1890. †JONES, Rev. EDWARD, F.G.S. Primrose Cottage, Embsay, Skipton.
1896. †Jones, E. Taylor, D.Sc. University College, Bangor.
1903. †Jones, Evan. Ty-Mawr, Aberdare.
1907. \*Jones, Mrs. Evan. 39 Hyde Park-gate, S.W.
1887. †Jones, Francis, F.R.S.E., F.C.S. 17 Whalley-road, Whalley Range, Manchester.
1891. \*JONES, Rev. G. HARTWELL, D.D. Nutfield Rectory, Redhill, Surrey.
1883. \*Jones, George Oliver, M.A. Inchyra House, 21 Cambridge-road, Waterloo, Liverpool.



Year of  
Election.

1912. †Jones, J. H. The University, Glasgow.
1913. †Jones, O. T., M.A., D.Sc., F.G.S., Professor of Geology in the University College of Wales. Fenton, Caradoc-road, Aberystwyth.
1905. †Jones, Miss Parnell. The Rectory, Llanddewi Skyrrid, Abergavenny, Monmouthshire.
1901. †Jones, R. E., J.P. Oakley Grange, Shrewsbury.
1902. †Jones, R. M., M.A. Royal Academical Institution, Belfast.
1908. †Jones, R. Pugh, M.A. County School, Holyhead, Anglesey.
1912. §Jones, W. Neilson, M.A. Bedford College, Regent's Park, N.W.
1875. \*Jose, J. E. *Ethersall, Tarbock-road, Huyton, Lancashire.*
1913. †Jourdain, Miss Eleanor F. St. Hugh's College, Oxford.
1883. †Joyce, Rev. A. G., B.A. St. John's Croft, Winchester.
1886. †Joyce, Hon. Mrs. St. John's Croft, Winchester.
1905. †Judd, Miss Hilda M., B.Sc. Berrymead, 6 Lichfield-road, Kew.
1894. §Julian, Mrs. Forbes. Redholme, Braddon's Hill-road, Torquay.
1914. †Julius, G. A., B.Sc. Culwulla-chambers, 67 Castlereagh-street, Sydney, N.S.W.
1905. §JURITZ, CHARLES F., M.A., D.Sc., F.I.C., Agricultural Research Chemist. Department of Agriculture, Cape Town.
1888. †KAPP, GISEBERT, M.Sc., M.Inst.C.E., M.Inst.E.E. (Pres. G, 1913), Professor of Electrical Engineering in the University of Birmingham. 43 Upland-road, Selly Park, Birmingham.
1913. †Kay, Henry, F.G.S. 16 Wretham-road, Handsworth, Birmingham.
1915. §Kay, Max M. 82 Daisy Bank-road, Victoria Park, Manchester.
1913. †Kaye, G. W. C. 76 Addison-gardens, Kensington, W.
1904. †Kayser, Professor H. The University, Bonn, Germany.
1892. †KEANE, CHARLES A., Ph.D. Sir John Cass Technical Institute, Jewry-street, Aldgate, E.C.
1913. †Kebby, Charles H. 75 Sterndale-road, West Kensington Park, W.
1908. †KEBBLE, FREDERICK, M.A., Sc.D., F.R.S. (Pres. K, 1912), Director of the Royal Horticultural Gardens, Wisley. Weyton, St. George's-hill, Weybridge.
1913. \*Keeling, B. F. E. Survey Department, Giza Branch, Egypt.
1911. \*Keith, Arthur, M.D., LL.D., F.R.S., F.R.C.S. Royal College of Surgeons, Lincoln's Inn-fields, W.C.
1884. †Kellogg, J. H., M.D. Battle Creek, Michigan, U.S.A.
1908. †Kelly, Sir Malachy. Ard Brugh, Dalkey, Co. Dublin.
1908. †Kelly, Captain Vincent Joseph. Montrose, Donnybrook, Co. Dublin.
1911. †Kelly, Miss. Montrose, Merton-road, Southsea.
1902. \*Kelly, William J., J.P. 25 Oxford-street, Belfast.
1885. §KELTIE, J. SCOTT, LL.D., Sec. R.G.S., F.S.S. (Pres. E, 1897; Council, 1898-1904.) Royal Geographical Society, Kensington Gore, S.W.
1887. †Kemp, Harry. 55 Wilbraham-road, Chorlton-cum-Hardy, Manchester.
1898. \*Kemp, John T., M.A. 27 Cotham-grove, Bristol.
1891. †KENDALL, PERCY F., M.Sc., F.G.S., Professor of Geology in the University of Leeds.
1875. †KENNEDY, SIR ALEXANDER B. W., LL.D., F.R.S., M.Inst.C.E. (Pres. G, 1894.) Athenæum Club, S.W.
1906. †Kennedy, Robert Sinclair. Glengall Ironworks, Millwall, E.
1908. †Kennedy, William. 40 Trinity College, Dublin.

Year of  
Election.

1905. \*Kennerley, W. R. P.O. Box 158, Pretoria.  
 1913. †KENRICK, W. BYNG. (Local Sec. 1913.) Metchley House,  
 Somerset-road, Edgbaston, Birmingham.  
 1893. §KENT, A. F. STANLEY, M.A., F.L.S., F.G.S., Professor of Physiology  
 in the University of Bristol.  
 1913. \*Kenyon, Joseph, B.Sc., F.I.C. 51 Irving-place, Blackburn.  
 1857. \*Ker, André Allen Murray. Newbliss House, Newbliss, Ireland.  
 1915. §Kerfoot, E. H. Springwood Hall, Ashton-under-Lyne.  
 1915. §Kerfoot, Thomas. Pole Bank Hall, Gee Cross, Cheshire.  
 1881. †KERMODE, P. M. C. Claghbene, Ramsey, Isle of Man.  
 1913. §Kerr, George L. 39 Elmbank-crescent, Glasgow.  
 1909. †Kerr, Hugh L. 68 Admiral-road, Toronto, Canada.  
 1892. †KERR, J. GRAHAM, M.A., F.R.S., Regius Professor of Zoology  
 in the University of Glasgow.  
 1889. †Kerry, W. H. R. The Sycamores, Windermere.  
 1910. §KERSHAW, J. B. C. West Lancashire Laboratory, Waterloo, Liver-  
 pool.  
 1869. \*Kesselmeyer, Charles Augustus. Roseville, Vale-road, Bowdon,  
 Cheshire.  
 1869. \*Kesselmeyer, William Johannes. Edelweiss Villa, 19 Broomfield-  
 lane, Hale, Cheshire.  
 1903. †Kewley, James. Balek Papan, Koltei, Dutch Borneo.  
 1883. \*Keynes, J. N., M.A., D.Sc., F.S.S. 6 Harvey-road, Cambridge.  
 1906. †Kidner, Henry, F.G.S. 25 Upper Rock-gardens, Brighton.  
 1886. §KIDSTON, ROBERT, LL.D., F.R.S., F.R.S.E., F.G.S. 12 Clarendon-  
 place, Stirling.  
 1901. \*Kiep, J. N. 137 West George-street, Glasgow.  
 1885. \*Kilgour, Alexander. Loirston House, Cove, near Aberdeen.  
 1896. \*Killey, George Deane, J.P. Bentuther, 11 Victoria-road, Waterloo,  
 Liverpool.  
 1890. †KIMMINS, C. W., M.A., D.Sc. The Old Heritage, Chailey, Sussex.  
 1914. †Kincaid, Miss Hilda S., D.Sc. Tarana, Kinkora-road, Hawthorn,  
 N.S.W.  
 1875. \*KINCH, EDWARD, F.I.C. Sunnyside, Chislehurst, Kent.  
 1875. \*King, F. Ambrose. Avonside, Clifton, Bristol.  
 1914. §King, Miss Georgina. Springfield, Darlington, N.S.W.  
 1871. \*King, Rev. Herbert Poole. The Rectory, Stourton, Bath.  
 1883. \*King, John Godwin. Stonelands, East Grinstead.  
 1883. \*King, Joseph, M.P. Sandhouse, Witley, Godalming.  
 1908. †King, Professor L. A. L., M.A. St. Mungo's College Medical  
 School, Glasgow.  
 1860. \*King, Mervyn Kersteman. Merchants' Hall, Bristol.  
 1912. \*King, W. B. R., B.A., F.G.S. Geological Survey, Jermyn-street,  
 S.W.  
 1912. †King, W. J. Harding. 25 York House, Kensington, W.  
 1870. †King, William, M.Inst.C.E. 5 Beach-lawn, Waterloo, Liverpool.  
 1913. \*King, William Wickham, F.G.S. Winds Point, Hagley, near  
 Stourbridge.  
 1909. †Kingdon, A. 197 Yale-avenue, Winnipeg, Canada.  
 1903. †Kingsford, H. S., M.A. 8 Elsworthy-terrace, N.W.  
 1900. †KIPPING, Professor F. STANLEY, D.Sc., Ph.D., F.R.S. (Pres. B,  
 1908.) University College, Nottingham.  
 1899. \*Kirby, Miss C. F. 8 Windsor-court, Moscow-road, W.  
 1913. §KIRKALDY, Professor A. W., M.Com. (Pres. F, 1916.) The  
 University, Edmund-street, Birmingham.  
 1916 §Kirkby, Rev. J. P. Saham Rectory, Watton, Norfolk.  
 1915. \*Kitson, A. E. 109 Worple-road, Wimbledon, S.W.

Year of  
Election.

1901. §Kitto, Edward. 2 Great Headland-terrace, Preston, Paignton, South Devon.
1915. †Knecht, E., Ph.D., Professor of Chemistry in the University of Manchester. 131 Sussex-road, Southport.
1914. §Knibbs, G. H., C.M.G., F.R.A.S., F.S.S., Commonwealth Statistician. Rialto, Collins-street, Melbourne.
1917. §Knight, Lieut.-Colonel C. Morley. 94 Piccadilly, W.
1886. †Knight, Captain J. M., F.G.S. Bushwood, Wanstead, Essex.
1912. †Knipe, Henry R., F.L.S., F.G.S. 9 Linden-park, Tunbridge Wells.
1888. †KNOTT, Professor CARGILL G., D.Sc., F.R.S.E. 42 Upper Gray-street, Edinburgh.
1887. \*Knott, Herbert, J.P. Sunnybank, Wilmslow, Cheshire.
1887. \*Knott, John F. Edgemoor, Burbage, Derbyshire.
1906. \*Knowles, Arthur J., B.A., M.Inst.C.E. 10 Drayton-court, Drayton-gardens, S.W.
1915. \*Knowles, Sir Lees, Bart., C.V.O. Westwood, Pendlebury, near Manchester.
1916. §Knowles, W. H. Sun-buildings, Newcastle-on-Tyne.
1874. †Knowles, William James. Flixton-place, Ballymena, Co. Antrim.
1915. §Knox, Principal George, F.G.S. Heol Isaf, Radyr, Glamorgan.
1902. †KNOX, R. KYLE, LL.D. 1 College-gardens, Belfast.
1875. \*Knubley, Rev. E. P., M.A. Steeple Ashton Vicarage, Trowbridge.
1883. †Knubley, Mrs. Steeple Ashton Vicarage, Trowbridge.
1890. \*Krauss, John Samuel, B.A. *Stonycroft, Knutsford-road, Wilmslow, Cheshire.*
1888. \*Kunz, G. F., M.A., Ph.D., Sc.D. Care of Messrs. Tiffany & Co., 11 Union-square, New York City, U.S.A.
1903. \*Lafontaine, Rev. H. C. de. 52 Albert-court, Kensington Gore, S.W.
1909. †Laird, Hon. David. Indian Commission, Ottawa, Canada.
1904. †Lake, Philip. St. John's College, Cambridge.
1904. †Lamb, C. G. Ely Villa, Glisson-road, Cambridge.
1889. \*Lamb, Edmund, M.A. Borden Wood, Liphook, Hants.
1915. †Lamb, Francis W. Lyndene, High Lane, near Stockport.
1887. †LAMB, HORACE, M.A., LL.D., D.Sc., F.R.S. (Pres. A, 1904), Professor of Mathematics in the Victoria University, Manchester. 6 Wilbraham-road, Fallowfield, Manchester.
1893. \*LAMPLUGH, G. W., F.R.S., F.G.S. (Pres. C, 1906.) 13 Beaconsfield-road, St. Albans.
1914. †Lane, Charles. Care of John Sanderson & Co., William-street, Melbourne.
1898. \*LANG, WILLIAM H., M.B., F.R.S. (Pres. K, 1915), Professor of Cryptogamic Botany in the University of Manchester. 2 Heaton-road, Withington, Manchester.
1886. \*LANGLEY, J. N., M.A., D.Sc., F.R.S. (Pres. I, 1899; Council, 1904-07), Professor of Physiology in the University of Cambridge. Trinity College, Cambridge.
1915. §Langton, J. L., M.Sc. Municipal School of Technology, Manchester.
1865. †LANKESTER, Sir E. RAY, K.C.B., M.A., LL.D., D.Sc., F.R.S. (PRESIDENT, 1906; Pres. D, 1883; Council, 1889-90, 1894-95, 1900-02.) 331 Upper Richmond-road, Putney, S.W.
1880. \*LANSDALE, Rev. HENRY, D.D., F.R.A.S., F.R.G.S. Dimsdale, 4 Pond-road, Blackheath Park, London, S.E.
1884. †LANZA, Professor G. Massachusetts Institute of Technology, Boston, U.S.A.

Year of  
Election.

1911. †Laphorn, Miss. St. Bernard's, Grove-road South, Southsea.  
 1885. †LAPWORTH, CHARLES, LL.D., F.R.S., F.G.S. (Pres. C, 1892.)  
 38 Calthorpe-road, Edgbaston, Birmingham.  
 1909. †Larard, C.E., Assoc.M.Inst.C.E. 14 Leaside-avenue, Muswell Hill, N.  
 1887. †Larmor, Alexander. Craglands, Helen's Bay, Co. Down.  
 1881. †LARMOR, Sir JOSEPH, M.A., D.Sc., F.R.S. (Pres. A, 1900), Lucasian  
 Professor of Mathematics in the University of Cambridge.  
 St. John's College, Cambridge.  
 1883. †Lascelles, B. P., M.A. Headland, Mount Park, Harrow.  
 1870. \*LATHAM, BALDWIN, M.Inst.C.E., F.G.S. Parliament-mansions,  
 Westminster, S.W.  
 1911. †Lattey, R. T. 243 Woodstock-road, Oxford.  
 1900. \*Lauder, Alexander, D.Sc., Lecturer in Agricultural Chemistry in  
 the Edinburgh and East of Scotland College of Agriculture,  
 Edinburgh.  
 1911. §Laurie, Miss C. L. 1 Vittoria-walk, Cheltenham.  
 1913. \*Laurie, Mrs. E. B. 11 Marine-parade, Hoylake.  
 1892. †LAURIE, MALCOLM, B.A., D.Sc., F.L.S. School of Medicine, Sur-  
 geons' Hall, Edinburgh.  
 1907. \*Laurie, Robert Douglas, M.A. Department of Zoology, The Uni-  
 versity, Liverpool.  
 1870. \*Law, Channell. Ilsham Dene, Torquay.  
 1914. †Lawrence, A. H. Urunga, N.S.W.  
 1905. †Lawrence, Miss M. Roedean School, near Brighton.  
 1911. \*Lawson, A. Anstruther, D.Sc., F.R.S.E., F.L.S., Professor of  
 Botany in the University, Sydney, N.S.W.  
 1908. †Lawson, H. S., B.A. Buxton College, Derbyshire.  
 1908. †Lawson, William, LL.D. 27 Upper Fitzwilliam-street, Dublin.  
 1914. †Layard, J. W. Bull Cliff, Felixstowe.  
 1888. †Layard, Miss Nina F., F.L.S. Rookwood, Fonnereau-road, Ipswich.  
 1913. §Lea, F. C., D.Sc., Professor of Civil Engineering in the University  
 of Birmingham. 36 Mayfield-road, Moseley, Birmingham.  
 1883. \*Leach, Charles Catterall. Seghill, Northumberland.  
 1894. \*LEAHY, A. H., M.A., Professor of Mathematics in the University of  
 Sheffield. 92 Ashdell-road, Sheffield.  
 1905. †Leake, E. O. 5 Harrison-street, Johannesburg.  
 1901. \*Lean, George, B.Sc. 3 Park-quadrant, Glasgow.  
 1904. \*Leatham, J. G. St. John's College, Cambridge.  
 1872. †LEBOUR, G. A., M.A., D.Sc., F.G.S., Professor of Geology in the  
 Armstrong College of Science, Newcastle-on-Tyne.  
 1910. †Lebour, Miss M. V., M.Sc. Zoological Department, The University,  
 Leeds.  
 1912. †Lechmere, A. Eckley, M.Sc. Townhope, Hereford.  
 1895. \*Ledger, Rev. Edmund. Protea, Doods-road, Reigate.  
 1914. †Lee, Charles Alfred. Tenterfield, N.S.W.  
 1910. \*Lee, Ernest. Birkbeck College, Chancery-lane, E.C.  
 1896. §Lee, Rev. H. J. Barton. 7 First-avenue, Broadway, Blackpool.  
 1907. §Lee, Mrs. Barton. 7 First-avenue, Broadway, Blackpool.  
 1909. §Lee, I. L. 26 Broadway, New York City, U.S.A.  
 1909. †Lee, Rev. J. W., D.D. 5068 Washington-avenue, St. Louis,  
 Missouri, U.S.A.  
 1894. \*Lee, Mrs. W. The Nook, Forest Row, Sussex.  
 1909. †Leeming, J. H., M.D. 406 Devon-court, Winnipeg, Canada.  
 1892. \*LEES, CHARLES H., D.Sc., F.R.S., Professor of Physics in the  
 East London College, Mile End. Greenacres, Woodside-road,  
 Woodford Green, Essex.  
 1915. †Lees, Mrs. H. L., F.R.G.S. Leedene, Hale, Altrincham.

Year of  
Election.

1912. †Lees, John. Pitscottie, Cupar-Fife, N.B.  
 1886. \*Lees, Lawrence W. Lynstone, Barnt Green.  
 1906. †Lees, Robert. Victoria-street, Fraserburgh.  
 1915. §Lees, S. School of Technology, Manchester.  
 1889. \*Leeson, John Rudd, M.D., C.M., F.L.S., F.G.S. Clifden House,  
 Twickenham, Middlesex.  
 1906. †Leetham, Sidney. Elm Bank, York.  
 1912. †LEGGAT, W. G. Bank of Scotland, Dundee.  
 1912. †Legge, James G. Municipal Buildings, Liverpool.  
 1910. §Leigh, H. S. Brentwood, Worsley, near Manchester.  
 1915. †Leigh, T. B. Arden, Bredbury, near Stockport.  
 1891. †Leigh, W. W. Glyn Bargoed, Treharris, R.S.O., Glamorganshire.  
 1903. †Leighton, G. R., M.D., F.R.S.E. Local Government Board,  
 Edinburgh.  
 1906. †Leiper, Robert T., M.B., F.Z.S. London School of Tropical  
 Medicine, Royal Albert Dock, E.  
 1905. †Leitch, Donald. P.O. Box 1703, Johannesburg.  
 1913. †Leith, Professor R. F. C., M.A., M.Sc. Pathological Laboratory,  
 The University, Birmingham.  
 1903. \*Lempfert, R. G. K., M.A. 66 Sydney-street, S.W.  
 1908. †Lentaigne, John. 42 Merrion-square, Dublin.  
 1901. §LEONARD, J. H., B.Sc. 31 Gunterstone-road, West Kensington,  
 W.  
 1915. §Leslie, Miss M. S., M.Sc. 1 Park View-terrace, Halton, near  
 Leeds.  
 1914. †Le Souef, W. H. D., C.M.Z.S. Zoological Gardens, Parkville,  
 Victoria, Australia.  
 1913. †Lessing, R., Ph.D. 317 High Holborn, W.C.  
 1912. \*Lessner, C., F.C.S. Carril, Spain.  
 1890. \*Lester, Joseph Henry. 5 Grange-drive, Monton Green, Manchester.  
 1904. \*Le Sueur, H. R., D.Sc. Chemical Laboratory, St. Thomas's  
 Hospital, S.E.  
 1900. †Letts, Professor E. A., D.Sc., F.R.S.E. Queen's University, Belfast.  
 1896. †Lever, Sir W. H., Bart. Thornton Manor, Thornton Hough,  
 Cheshire.  
 1913. †Levick, John. Livingstone House, Livingstone-road, Handsworth,  
 Birmingham.  
 1904. \*Lewis, Mrs. Agnes S., LL.D. Castle Brae, Chesterton-lane, Cam-  
 bridge.  
 1870. †LEWIS, ALFRED LIONEL. 35 Beddington-gardens, Wallington,  
 Surrey.  
 1891. †Lewis, Professor D. Morgan, M.A. University College, Aberystwyth.  
 1913. †Lewis, E. O. Gwynfa, Alma-street, Brynmawr.  
 1899. †Lewis, Professor E. P. University of California, Berkeley, U.S.A.  
 1910. †LEWIS, FRANCIS J., D.Sc., F.L.S., Professor of Biology in the  
 University of Alberta, Edmonton, Alberta, Canada.  
 1904. †Lewis, Hugh. Glanafrau, Newtown, Montgomeryshire.  
 1910. \*LEWIS, T. C. West Home, West-road, Cambridge.  
 1911. §Lewis, W. C. McC., M.A., D.Sc., Professor of Physical Chemistry  
 in the University of Liverpool.  
 1906. †Liddiard, James Edward, F.R.G.S. Rodborough Grange, Bourne-  
 mouth.  
 1913. \*Lillie, D. G. St. John's College, Cambridge.  
 1908. †Lilly, W. E., M.A., Sc.D. 39 Trinity College, Dublin.  
 1904. †Link, Charles W. 14 Chichester-road, Croydon.  
 1913. \*Lishman, G. P., D.Sc., F.I.C. Chemical Laboratory, Lambton  
 Coke Works, Fence Houses, Co. Durham.

Year of  
Election.

1888. †**LISTER**, J. J., M.A., F.R.S. (Pres. D, 1906.) St. John's College, Cambridge.
1861. \***LIVEING**, G. D., M.A., F.R.S. (Pres. B, 1882; Council, 1888-95; Local Sec. 1862.) Newnham, Cambridge.
1876. \***LIVERSIDGE**, ARCHIBALD, M.A., F.R.S., F.C.S., F.G.S., F.R.G.S. Fieldhead, George-road, Kingston Hill, Surrey.
1902. §**Llewellyn**, Evan. Working Men's Institute and Hall, Blaenavon.
1912. †**Lloyd**, Miss Dorothy Jordan. 16 Ampton-road, Edgbaston, Birmingham.
1909. §**Lloyd**, George C., Secretary of the Iron and Steel Institute. 28 Victoria-street, S.W.
1903. †**Lloyd**, Godfrey I. H. The University of Toronto, Canada.
1892. †**LOCH**, Sir C. S., D.C.L. Denison House, Vauxhall Bridge-road, S.W.
1905. †**Lochrane**, Miss T. 8 Prince's-gardens, Dowanhill, Glasgow.
1904. †**Lock**, Rev. J. B. Herschel House, Cambridge.
1863. †**LOCKYER**, Sir J. NORMAN, K.C.B., LL.D., D.Sc., F.R.S. (PRESIDENT, 1903; Council, 1871-76, 1901-02.) 16 Penywern-road, S.W.
1902. \***Lockyer**, Lady. 16 Penywern-road, S.W.
1914. †**LOCKYER**, Ormonde H. S. 126 Webster-street, Ballarat, Victoria.
1900. §**LOCKYER**, W. J. S., Ph.D. 16 Penywern-road, S.W.
1886. \***LODGE**, ALFRED, M.A. (Council, 1913-15.) The Croft, Peperharow-road, Godalming.
1914. †**Lodge**, Miss Lorna L. Mariemont, Edgbaston, Birmingham.
1914. †**Lodge**, Miss Norah M. Mariemont, Edgbaston, Birmingham.
1875. \***LODGE**, Sir OLIVER J., D.Sc., LL.D., F.R.S. (PRESIDENT, 1913; Pres. A, 1891; Council, 1891-97, 1899-1903, 1912-13), Principal of the University of Birmingham.
1914. †**Lodge**, Lady. Mariemont, Edgbaston, Birmingham.
1894. \***Lodge**, Oliver W. F. Nurton Farm, Tintern, Monmouthshire.
1915. §**Lomas**, L. H., B.Sc. Butley Cottage, Prestbury, Cheshire.
1915. §**Lomax**, James, A.L.S. 65 Starcliffe-street, Great Lever, Bolton.
1899. †**Loncq**, Emile. 6 Rue de la Plaine, Laon, Aisne, France.
1903. †**Long**, Frederick. The Close, Norwich.
1905. †**Long**, W. F. City Engineer's Office, Cape Town.
1910. \***Longden**, G. A. Draycott Lodge, Derby.
1904. \***Longden**, J. A., M.Inst.C.E. Chislehurst, Marlborough-road, Bournemouth.
1898. \***Longfield**, Miss Gertrude. Belmont, High Halstow, Rochester.
1901. \***Longstaff**, Major Frederick V., F.R.G.S. Care of Wimbledon Common Branch, London County and Westminster Bank, Wimbledon, S.W.
1875. \***Longstaff**, George Blundell, M.A., M.D., F.C.S., F.S.S. Highlands, Putney Heath, S.W.
1872. \***Longstaff**, Lieut.-Colonel Llewellyn Wood, F.R.G.S. Ridgelsands, Wimbledon, S.W.
1881. \***Longstaff**, Mrs. Ll. W. Ridgelsands, Wimbledon, S.W.
1899. \***Longstaff**, Tom G., M.A., M.D. Picket Hill, Ringwood.
1896. †**Louis**, Henry, D.Sc., Professor of Mining in the Armstrong College of Science, Newcastle-on-Tyne.
1887. \***LOVE**, A. E. H., M.A., D.Sc., F.R.S. (Pres. A, 1907), Professor of Natural Philosophy in the University of Oxford. 34 St. Margaret's-road, Oxford.
1886. \***Love**, E. F. J., M.A., D.Sc. The University, Melbourne, Australia.
1904. \***Love**, J. B., LL.D. Outlands, Devonport.
1876. \***Love**, James, F.R.A.S., F.G.S., F.Z.S. 33 Clanricarde-gardens, W.
1916. §**Loveday**, Thomas. 1 Grosvenor-villas, Newcastle-on-Tyne.
1908. §**Low**, Alexander, M.A., M.D. The University, Aberdeen.

Year of  
Election.

1909. †Low, David, M.D. 1927 Scarth-street, Regina, Saskatchewan, Canada.
1912. †Low, William. Balmakewan, Seaview, Monifieth.
1885. §Lowdell, Sydney Poole. Baldwin's Hill, East Grinstead, Sussex.
1891. §Lowdon, John. St. Hilda's, Barry, Glamorgan.
1885. \*Lowe, Arthur C. W. Gosfield Hall, Halstead, Essex.
1886. \*Lowe, John Landor. B.Sc., M.Inst.C.E. Welland Lodge, Prestbury-road, Cheltenham.
1894. †Lowenthal, Miss Nellie. Woodside, Egerton, Huddersfield.
1903. \*LOWRY, Dr. T. MARTIN, F.R.S. 17 Eliot-park, Lewisham, S.E.
1913. §LUCAS, Sir CHARLES P., K.C.B., K.C.M.G. (Pres. E, 1914.)  
65 St. George's-square, S.W.
1913. §Lucas, Harry. Hilver, St. Agnes-road, Moseley, Birmingham.
1891. \*Lucovich, Count A. Tyn-y-parc, Whitchurch, near Cardiff.
1906. †Ludlam, Ernest Bowman. College Gate, 32 College-road, Clifton, Bristol.
1883. \*Lupton, Arnold, M.Inst.C.E., F.G.S. 7 Victoria-street, S.W.
1914. †Lupton, Mrs. 7 Victoria-street, S.W.
1874. \*LUPTON, SYDNEY, M.A. (Local Sec. 1890.) 102 Park-street, Grosvenor-square, W.
1898. †Luxmoore, Dr. C. M., F.I.C. 19 Disraeli-gardens, Putney, S.W.
1903. †Lyddon, Ernest H. Lisvane, near Cardiff.
1916. §Lye, W. T. Legrave Hall, near Luton, Beds.
1871. †Lyell, Sir Leonard, Bart., F.G.S. Kinnordy, Kirriemuir.
1916. §Lyle, R. P. Rankin. Holmwood, Clayton-road, Newcastle-on-Tyne.
1914. †LYLE, Professor T. R., M.A., Sc.D., F.R.S. Irving-road, Toorak, Victoria, Australia.
1912. \*Lynch, Arthur, M.A., M.P. 80 Antrim-mansions, Haverstock Hill, N.W.
1907. \*LYONS, Major HENRY GEORGE, D.Sc., F.R.S. (Pres. E, 1915; Council, 1912-15.) 3 Durham-place, Chelsea, S.W.
1908. †Lyster, George H. 34 Dawson-street, Dublin.
1908. †Lyster, Thomas W., M.A. National Library of Ireland, Kildare-street, Dublin.
1905. †Maberly, Dr. John. Shirley House, Woodstock, Cape Colony.
1868. †MACALISTER, ALEXANDER, M.A., M.D., F.R.S. (Pres. H, 1892; Council, 1901-06), Professor of Anatomy in the University of Cambridge. Torrisdale, Cambridge.
1878. †MACALISTER, Sir DONALD, K.C.B., M.A., M.D., LL.D., B.Sc., Principal of the University of Glasgow.
1904. †Macalister, Miss M. A. M. Torrisdale, Cambridge.
1896. †MACALUM, Professor A. B., Ph.D., D.Sc., F.R.S. (Pres. I, 1910; Local Sec. 1897.) 59 St. George-street, Toronto, Canada.
1914. †McAlpine, D. Berkeley-street, Hawthorn, Victoria, Australia.
1915. §Macara, Sir C. W. Ardmore, St. Anne's-on-Sea.
1909. †MacArthur, J. A., M.D. Canada Life-building, Winnipeg, Canada.
1896. \*Macaulay, F. S., M.A. The Chesters, Vicarage-road, East Sheen, S.W.
1904. \*Macaulay, W. H. King's College, Cambridge.
1896. †MACBRIDE, E. W., M.A., D.Sc., F.R.S. (Pres. D, 1916), Professor of Zoology in the Imperial College of Science and Technology, S.W.
1902. \*Maccall, W. T., M.Sc. Technical College, Sunderland.

Year of  
Election.

1912. †McCallum, George Fisher. 142 St. Vincent-street, Glasgow.  
 1912. †McCallum, Mrs. Lizzie. 142 St. Vincent-street, Glasgow.  
 1886. †MacCarthy, Rev. E. F. M., M.A. 50 Harborne-road, Edgbaston,  
 Birmingham.  
 1908. §McCarthy, Edward Valentine, J.P. Ardmanagh House, Glenbrook,  
 Co. Cork.  
 1909. †McCarthy, J. H. Public Library, Winnipeg, Canada.  
 1884. \*McCarthy, J. J., M.D. 11 Wellington-road, Dublin.  
 1904. §McClelland, Frank Kennedy. Rusthall House, Tunbridge Wells.  
 1902. †McClelland, J. A., M.A., F.R.S., Professor of Physics in University  
 College, Dublin.  
 1906. †McClure, Rev. E. 80 Eccleston-square, S.W.  
 1878. \*McComas, Henry. 12 Elgin-road, Dublin.  
 1908. \*McCOMBIE, HAMILTON, M.A., Ph.D. The University, Birmingham.  
 1914. \*McCombie, Mrs. Hamilton. The University, Birmingham.  
 1901. \*MacConkey, Alfred. Lister Lodge, Elstree, Herts.  
 1915. †McConnel, John W. Wellbank, Prestwich.  
 1901. †McCrae, John, Ph.D. 7 Kirklee-gardens, Glasgow.  
 1912. †MacCulloch, Rev. Canon J. A., D.D. The Rectory, Bridge of Allan.  
 1905. §McCulloch, Principal J. D. Free College, Edinburgh.  
 1904. †McCulloch, Major T., R.A. 68 Victoria-street, S.W.  
 1915. §McDonald, Dr. Archie W. Glencoe, Huyton, Liverpool.  
 1909. †MacDonald, Miss Eleanor. Fort Qu'Appelle, Saskatchewan, Canada.  
 1904. †MACDONALD, H. M., M.A., F.R.S., Professor of Mathematics in the  
 University of Aberdeen.  
 1905. †McDonald, J. G. P.O. Box 67, Bulawayo.  
 1900. †MacDonald, J. Ramsay, M.P. 3 Lincoln's Inn-fields, W.C.  
 1905. †MACDONALD, J. S., B.A. (Pres. I, 1911), Professor of Physiology in  
 the University of Sheffield.  
 1884. \*Macdonald, Sir W. C. 449 Sherbrooke-street West, Montreal, Canada.  
 1909. †MacDonell, John, M.D. Portage-avenue, Winnipeg, Canada.  
 1909. \*MacDougall, R. Stewart. The University, Edinburgh.  
 1915. \*McDougall, Robert, B.Sc. Lerryn, Carr Wood-road, Chendle  
 Hulme, Stockport.  
 1912. †McDougall, Dr. W., F.R.S. 89 Banbury-road, Oxford.  
 1916. §McDowall, Professor J. W. East Cottingwood, Morpeth.  
 1906. §McFarlane, John, M.A. 48 Parsonage-road, Withington, Manchester.  
 1885. †Macfarlane, J. M., D.Sc., F.R.S.E., Professor of Biology in the  
 University of Pennsylvania. Lansdowne, Delaware Co., Penn-  
 sylvania, U.S.A.  
 1901. †Macfee, John. 5 Greenlaw-terrace, Paisley.  
 1909. †Macgachen, A. F. D. 281 River-avenue, Winnipeg, Canada.  
 1888. †MacGeorge, James. 8 Matheson-road, Kensington, W.  
 1908. †McGRATH, Sir JOSEPH, LL.D. (Local Sec. 1908.) Royal University  
 of Ireland, Dublin.  
 1908. †McGregor, Charles. Training Centre, Charlotte-street, Aberdeen.  
 1906. †MACGREGOR, D. H., M.A. Trinity College, Cambridge.  
 1867. \*McINTOSH, W. C., M.D., LL.D., F.R.S., F.R.S.E., F.L.S. (Pres. D,  
 1885), Professor of Natural History in the University of  
 St. Andrews. 2 Abbotsford-crescent, St. Andrews, N.B.  
 1909. †McIntyre, Alexander. 142 Maryland-avenue, Winnipeg, Canada.  
 1909. †McIntyre, Daniel. School Board Offices, Winnipeg, Canada.  
 1912. †McIntyre, J. Lewis, M.A., D.Sc. Abbotsville, Cults, Aberdeen-  
 shire.  
 1909. †McIntyre, W. A. 339 Kennedy-street, Winnipeg, Canada.  
 1884. §MacKay, A. H., B.Sc., LL.D., Superintendent of Education.  
 Education Office, Halifax, Nova Scotia, Canada.



- Year of Election.
1913. \*Mackay, John. 85 Bay-street, Toronto, Canada.
1915. †Mackay, John. 46 Acomb-street, Manchester.
1885. †MACKAY, JOHN YULE, M.D., LL.D., Principal of and Professor of Anatomy in University College, Dundee.
1912. †Mackay, R. J. 27 Arkwright-road, Hampstead, N.W.
1908. †McKay, William, J.P. Clifford-chambers, York.
1873. †McKENDRICK, JOHN G., M.D., LL.D., F.R.S., F.R.S.E. (Pres. I, 1901; Council, 1903-09), Emeritus Professor of Physiology in the University of Glasgow. Maxieburn, Stonehaven, N.B.
1909. †McKenty, D. E. 104 Colony-street, Winnipeg, Canada.
1907. †McKENZIE, Professor ALEXANDER, M.A., D.Sc., Ph.D., F.R.S. University College, Dundee.
1905. †Mackenzie, Hector. Standard Bank of South Africa, Cape Town.
1897. †McKenzie, John J. 61 Madison-avenue, Toronto, Canada.
1910. †Mackenzie, K. J. J., M.A. 10 Richmond-road, Cambridge.
1909. §MacKenzie, Kenneth. Royal Alexandra Hotel, Winnipeg, Canada.
1901. \*Mackenzie, Thomas Brown. Netherby, Manse-road, Motherwell, N.B.
1912. §Mackenzie, William, J.P. 22 Meadowside, Dundee.
1872. \*Mackey, J. A. United University Club, Pall Mall East, S.W.
1901. †Mackie, William, M.D. 13 North-street, Elgin.
1887. †MACKINDER, H. J., M.A., M.P., F.R.G.S. (Pres. E, 1895; Council, 1904-05.) 10 Chelsea-court, Chelsea Embankment, S.W.
1911. †Mackinnon, Miss D. L. University College, Dundee.
1916. \*Mackley, Edward H. Hawk's-road, Gateshead.
1915. §McLardy, Samuel. Basford Mount, Higher Crumpsall.
1893. \*McLaren, Mrs. E. L. Colby, M.B., Ch.B. 137 Tettenhall-road, Wolverhampton.
1901. \*Maclaren, J. Malcolm. *Royal Colonial Institute, Northumberland-avenue, W.C.*
1901. †Maclay, William. Thornwood, Langside, Glasgow.
1901. †McLean, Angus, B.Sc. Harvale, Meikleriggs, Paisley.
1892. \*MACLEAN, MAGNUS, M.A., D.Sc., F.R.S.E. (Local Sec. 1901), Professor of Electrical Engineering, Technical College, Glasgow.
1912. §McLean, R. C., B.Sc. Duart, Holmes-road, Reading.
1908. §McLennan, J. C., Ph.D., F.R.S., Professor of Physics in the University of Toronto, Canada.
1868. †McLEOD, HERBERT, LL.D., F.R.S. (Pres. B, 1892; Council, 1885-90.) 37 Montague-road, Richmond, Surrey.
1909. †MacLeod, M. H. C.N.R. Depot, Winnipeg, Canada.
1883. †MACMAHON, Major PERCY A., D.Sc., LL.D., F.R.S. (TRUSTEE, 1913-; GENERAL SECRETARY, 1902-13; Pres. A, 1901; Council, 1898-1902.) 27 Evelyn-mansions, Carlisle-place, S.W.
1909. †McMILLAN, The Hon. Sir DANIEL H., K.C.M.G. Government House, Winnipeg, Canada.
1902. †McMordie, Robert J. Cabin Hill, Knock, Co. Down.
1914. §Macnab, Angus D. Oakbank, Tullamarine, Victoria, Australia.
1914. †Macnicol, A. N. 31 Queen-street, Melbourne.
1878. †Macnie, George. 59 Bolton-street, Dublin.
1905. §Macphail, S. Rutherford, M.D. Rowditch, Derby.
1909. †MacPhail, W. M. P.O. Box 88, Winnipeg, Canada.
1907. †Macrosty, Henry W. 29 Hervey-road, Blackheath, S.E.
1906. †Macturk, G. W. B. 15 Bowlalley-lane, Hull.
1908. †McVittie, R. B., M.D. 62 Fitzwilliam-square North, Dublin.
1908. †McWalter, J. C., M.D., M.A. 19 North Earl-street, Dublin.

Year of  
Election.

1902. †McWeeney, Professor E. J., M.D. 84 St. Stephen's-green, Dublin.
1910. †McWilliam, Dr. Andrew. Kalimate, B.N.R., near Calcutta.
1908. †MADDEEN, Rt. Hon. Mr. Justice. Nutley, Booterstown, Dublin.
1905. †Magenis, Lady Louisa. 34 Lennox-gardens, S.W.
1909. †Magnus, Laurie, M.A. 12 Westbourne-terrace, W.
1875. \*MAGNUS, Sir PHILIP, B.Sc., B.A., M.P. (Pres. L, 1907.) 16 Gloucester-terrace, Hyde Park, W.
1908. \*Magson, Egbert H. Westminster College, Horseferry-road, S.W.
1907. \*Mair, David. Civil Service Commission, Burlington-gardens, W.
1902. \*Mairet, Mrs. Ethel M. The Thatched House, Shottery, Stratford-on-Avon.
1914. †Maitland, A. Gibb. Geological Survey, Perth, Western Australia.
1913. †Maitland, T. Gwynne, M.D. The University, Edmund-street, Birmingham.
1908. \*Makower, W., M.A., D.Sc. The University, Manchester.
1914. †Malinowski, B. London School of Economics, Clare Market, W.C.
1912. †Malloch, James, M.A., F.S.A. (Scot.). Training College, Dundee.
1905. †Maltby, Lieutenant G. R., R.N. 54 St. George's-square, S.W.
1897. †Mance, Sir H. C. Old Woodbury, Sandy, Bedfordshire.
1915. §Mandleberg, G. C. Redclyffe, Victoria Park, Manchester.
1903. †Manifold, C. C. 16 St. James's-square, S.W.
1894. †Manning, Percy, M.A., F.S.A. Watford, Herts.
1915. §Manson, John Sinclair, M.D. 8 Winmarleigh-street, Warrington.
1902. \*MARCHANT, E. W., D.Sc., David Jardine Professor of Electrical Engineering in the University of Liverpool.
1912. †Marchant, Rev. James, F.R.S.E. 42 Great Russell-street, W.C.
1898. \*Mardon, Heber. Clifden, Teignmouth, South Devon.
1911. \*MARETT, R. R., D.Sc. (Pres. H, 1916.) Exeter College, Oxford.
1900. †Margerison, Samuel. Calverley Lodge, near Leeds.
1905. §Marks, Samuel. P.O. Box 379, Pretoria.
1905. †MARLOTH, R., M.A., Ph.D. P.O. Box 359, Cape Town.
1881. \*MARE, J. E., M.A., D.Sc., F.R.S., F.G.S. (Pres. C, 1896 ; Council, 1896-1902, 1910-14.) St. John's College, Cambridge.
1892. \*Marsden-Smedley, J. B. Lea Green, Cromford, Derbyshire.
1883. \*Marsh, Henry Carpenter. 3 Lower James-street, Golden-square, W.
1887. †Marsh, J. E., M.A., F.R.S. University Museum, Oxford.
1915. †Marsh, J. H., M.D. Cumberland House, Macclesfield.
1889. \*MARSHALL, ALFRED, M.A., LL.D., D.Sc. (Pres. F, 1890.) Balliol Croft, Madingley-road, Cambridge.
1912. †Marsh, Professor C. R., M.A., M.D. The Medical School, Dundee.
1904. †Marshall, F. H. A. University of Edinburgh.
1889. †Marshall, Frank. Claremont House, Newcastle-on-Tyne.
1905. †Marshall, G. A. K. 6 Chester-place, Hyde Park-square, W.
1899. †Martin, Miss A. M. Park View, 32 Bayham-road, Sevenoaks.
1911. †MARTIN, Professor CHARLES JAMES, M.B., D.Sc., F.R.S., Director of the Lister Institute, Chelsea-gardens, S.W.
1889. \*Martin, Thomas Henry, Assoc.M.Inst.C.E. Windermere, Mount Pleasant-road, Hastings.
1912. †MARTIN, W. H. BLYTH. (Local Sec. 1912.) City Chambers, Dundee.
1916. §Martin, William, M.A., M.D. West Villa, Akenside-terrace, Newcastle-on-Tyne.
1911. §Martindell, E. W., M.A. Royal Anthropological Institute, 50 Great Russell-street, W.C.

Year of  
Election.

1913. †MARTINEAU, Lieut.-Colonel ERNEST, V.D. Ellerslie, Augustus-road, Edgbaston, Birmingham.
1913. §Martineau, P. E. The Woodrow, near Bromsgrove, Worcester.
1907. †Masefield, J. R. B., M.A. Rosehill, Cheadle, Staffordshire.
1905. \*Mason, Justice A. W. Supreme Court, Pretoria.
1913. \*Mason, Edmund W., B.A. 2 York-road, Edgbaston, Birmingham.
1893. \*Mason, Thomas. Enderleigh, Alexandra Park, Nottingham.
1915. \*Mason, Rev. W. A. Parker. Hulme Grammar School, Alexandra Park, Manchester.
1913. †Mason, William. Engineering Laboratory, The University, Liverpool.
1891. \*Massey, William H., M.Inst.C.E. Twyford, R.S.O., Berkshire.
1885. †MASSON, DAVID ORME, D.Sc., F.R.S., Professor of Chemistry in the University of Melbourne.
1910. †Masson, Irvine, M.Sc. University College, W.C.
1905. §Massy, Miss Mary. 2 Duke-street, Bath.
1901. \*Mather, G. R. Sunnyville, Park-crescent, Wellingborough.
1910. \*Mather, Thomas, F.R.S., Professor of Electrical Engineering in the City and Guilds of London Institute, Exhibition-road, S.W.
1915. §MATHIER, Right Hon. Sir WILLIAM, M.Inst.C.E. Bramble Hill Lodge, Bramshaw, New Forest.
1909. †Mathers, Mr. Justice. 16 Edmonton-street, Winnipeg, Canada.
1913. †Matheson, Miss M. Cecile. Birmingham Women's Settlement, 318 Summer-lane, Birmingham.
1908. †Matheson, Sir R. E., LL.D. Charlemont House, Rutland-square, Dublin.
1894. †MATHEWS, G. B., M.A., F.R.S. 10 Menai View, Bangor, North Wales.
1902. †MATLEY, C. A., D.Sc. Military Accounts Department, 6 Esplanade East, Calcutta, India.
1904. †Matthews, D. J. The Laboratory, Citadel Hill, Plymouth.
1899. \*Maufe, Herbert B., B.A., F.G.S. P.O. Box 168, Bulawayo, Rhodesia.
1914. †Maughan, M. M., B.A., Director of Education. Parkside, South Australia.
1893. †Mavor, Professor James. University of Toronto, Canada.
1905. \*Maylard, A. Ernest. 12 Blythwood-square, Glasgow.
1905. †Maylard, Mrs. 12 Blythwood-square, Glasgow.
1904. †Mayo, Rev. J., LL.D. 6 Warkworth-terrace, Cambridge.
1916. §Measham, Miss C. E. C. 128 New-walk, Leicester.
1912. §MEEK, ALEXANDER, M.Sc., Professor of Zoology in the Armstrong College of Science, Newcastle-on-Tyne.
1913. §Megson, A. L. Cambridge-street, Manchester.
1879. §Meiklejohn, John W. S., M.D. 105 Holland-road, W.
1908. †Meldrum, A. N., D.Sc. *Chemical Department, The University, Manchester.*
1915. §Melland, W. 23 King-street, Manchester.
1883. †Mellis, Rev. James. 23 Part-street, Southport.
1879. \*Mellish, Henry. Hodssock Priory, Worksop.
1881. §Melrose, James. Clifton Croft, York.
1905. \*Melvill, E. H. V., F.G.S., F.R.G.S. P.O. Val, Standerton District, Transvaal.
1901. †Mennell, F. P., F.G.S. 49 London Wall, E.C.
1913. \*Mentz-Tolley, Richard, J.P. Lynn Hall, Lichfield.
1909. †Menzies, Rev. James, M.D. Hwaichingfu, Honan, China.
1914. §Meredith, Mrs. C. M. 55 Bryansburn-road, Bangor, Co. Down.

- Year of Election.
1905. †Meredith, H. O., M.A., Professor of Economics in Queen's University, Belfast. 55 Bryansburn-road, Bangor, Co. Down.
1899. \*Merrett, William H., F.I.C. Hatherley, Grosvenor-road, Wallington, Surrey.
1899. †Merryweather, J. C. 4 Whitehall-court, S.W.
1915. †Merton, Thomas R. 25 Gilbert-street, W.
1916. \*Merz, Charles H. Collingwood-buildings, Newcastle-on-Tyne.
1889. \*Merz, John Theodore. The Quarries, Newcastle-upon-Tyne.
1914. §Messent, A. E. 80 Regent-street, Millswood, Goodwood, South Australia.
1905. †Methven, Cathcart W. Club Arcade, Smith-street, Durban.
1896. §Metzler, W. H., Ph.D., Professor of Mathematics in Syracuse University, Syracuse, New York, U.S.A.
1915. †Meunier, Stanislas. Gas Works, Stockport.
1915. †Meunier, Mrs. 16 Gibson-road, Heaton Chapel, Stockport.
1869. †MIALL, LOUIS C., D.Sc., F.R.S., F.L.S., F.G.S. (Pres. D, 1897; Pres. L, 1908; Local Sec. 1890.) 21 Norton Way North, Letchworth.
1903. \*Micklethwait, Miss Frances M. G. 17 St. Mary's-terrace, Paddington, W.
1881. \*Middlesbrough, The Right Rev. Richard Lacy, D.D., Bishop of Bishop's House, Middlesbrough.
1904. †MIDDLETON, T. H., C.B., M.A. (Pres. M, 1912.) Board of Agriculture and Fisheries, 4 Whitehall-place, S.W.
1894. \*MIERS, SIR HENRY A., M.A., D.Sc., F.R.S., F.G.S. (Pres. C, 1905; Pres. L, 1910), Vice-Chancellor of the University of Manchester. Birch Heys, Cromwell Range, Fallowfield, Manchester.
1885. †MILL, HUGH ROBERT, D.Sc., LL.D., F.R.S.E., F.R.G.S. (Pres. E, 1901.) 62 Camden-square, N.W.
1905. †Mill, Mrs. H. R. 62 Camden-square, N.W.
1912. †MILLAR, DR. A. H. (Local Sec. 1912.) Albert Institute, Dundee.
1889. \*MILLAR, ROBERT COCKBURN. 30 York-place, Edinburgh.
1909. §Miller, A. P. Glen Miller, Ontario, Canada.
1915. †Miller, Dr. Alexander K. 4 Darley-avenue, West Didsbury.
1895. †Miller, Thomas, M.Inst.C.E. 9 Thoroughfare, Ipswich.
1897. \*Miller, Willet G., Provincial Geologist. Provincial Geologist's Office, Toronto, Canada.
1904. †Millis, C. T. Hollydene, Wimbledon Park-road, Wimbledon.
1905. †Mills, Mrs. A. A. Ceylon Villa, Blinco-grove, Cambridge.
1908. †Mills, Miss E. A. Nurney, Glenagarey, Co. Dublin.
1868. \*MILLS, EDMUND J., D.Sc., F.R.S., F.C.S. 64 Twyford-avenue, West Acton, W.
1908. §Mills, John Arthur, M.B. Durham County Asylum, Winterton, Ferryhill.
1908. §Mills, W. H., M.Inst.C.E. Nurney, Glenagarey, Co. Dublin.
1902. †Mills, W. Sloan, M.A. Vine Cottage, Donaghmore, Newry.
1907. †Milne, A., M.A. University School, Hastings.
1910. §Milne, J. B. Cross Grove House, Totley, near Sheffield.
1910. \*Milne, James Robert, D.Sc., F.R.S.E. 5 North Charlotte-street, Edinburgh.
1903. \*Milne, R. M. Royal Naval College, Dartmouth, South Devon.
1898. \*MILNER, S. ROSLINGTON, D.Sc. The University, Sheffield.
1908. §Milroy, T. H., M.D., Dunville Professor of Physiology in Queen's University, Belfast.
1907. §MILTON, J. H., F.G.S., F.L.S., F.R.G.S. 8 College-avenue, Crosby, Liverpool.

- Year of Election.
1914. †Minchin, Mrs. 53 Cheyne-court, Chelsea, S.W.
1901. \*Mitchell, Andrew Acworth. 7 Huntly-gardens, Glasgow.
1913. \*Mitchell, Francis W. V. 25 Augustus-road, Edgbaston, Birmingham.
1901. \*Mitchell, G. A. 5 West Regent-street, Glasgow.
1909. †Mitchell, J. F. 211 Rupert-street, Winnipeg, Canada.
1883. †MITCHELL, P. CHALMERS, M.A., D.Sc., F.R.S., Sec.Z.S. (Pres. D, 1912; Council, 1906-13.) Zoological Society, Regent's Park, N.W.
1905. \*Mitchell, W. E. C. Box 129, Johannesburg.
1908. †Mitchell, W. M. 2 St. Stephen's Green, Dublin.
1914. †Mitchell, William, M.A., D.Sc., Hughes Professor of Philosophy and Economics in the University of Adelaide, South Australia.
1895. \*Moat, William, M.A. Johnson Hall, Ecoleshall, Staffordshire.
1908. †Moffat, C. B. 36 Hardwicke-street, Dublin.
1905. †Moir, James, D.Sc. Mines Department, Johannesburg.
1905. §Molengraaff, Professor G. A. F. Voorstraat 60, Delft, The Hague.
1883. †Mollison, W. L., M.A. Clare College, Cambridge.
1900. \*MONCKTON, H. W., Treas. L.S., F.G.S. 3 Harcourt-buildings, Temple, E.C.
1905. †Moncrieff, Lady Scott. 11 Cheyne-walk, S.W.
1891. \*Mond, Robert Ludwig, M.A., F.R.S.E., F.G.S. Combe Bank, Sevenoaks.
1915. §Moodie, J. Williams Deacon's Bank, Manchester.
1909. †Moody, A. W., M.D. 432½ Main-street, Winnipeg, Canada.
1909. \*MOODY, G. T., D.Sc. Lorne House, Dulwich, S.E.
1914. §Moody, Mrs. Lorne House, Dulwich, S.E.
1912. §MOORE, BENJAMIN, D.Sc., F.R.S. (Pres. I, 1914.) 8 Pembroke-villas, The Green, Richmond, Surrey.
1911. §Moore, E. S., Professor of Geology and Mineralogy in the School of Mines, Pennsylvania State College, Pennsylvania, U.S.A.
1908. \*MOORE, Sir F. W. Royal Botanic Gardens, Glasnevin, Dublin.
1894. †Moore, Harold E. Oaklands, The Avenue, Beckenham, Kent.
1908. †Moore, Sir John W., M.D. 40 Fitzwilliam-square West, Dublin
1901. \*Moore, Robert T. 142 St. Vincent-street, Glasgow.
1905. †Moore, T. H. Thornhill Villa, Marsh, Huddersfield.
1916. §Moore, Professor T. S. Hillside, Egham, Surrey.
1892. †Moray, The Right Hon. the Earl of, F.G.S. Kinfauns Castle, Perth.
1912. †Moray, The Countess of. Kinfauns Castle, Perth.
1896. \*MORDEY, W. M. 82 Victoria-street, S.W.
1901. \*Moreno, Francisco P. Paraná 915, Buenos Aires.
1905. \*Morgan, Miss Annie. Care of London County and Westminster Bank, Chancery-lane, W.C.
1895. †MORGAN, C. LLOYD, F.R.S., F.G.S., Professor of Psychology in the University of Bristol.
1902. †MORGAN, GILBERT T., D.Sc., F.I.C., Professor of Chemistry in the City and Guilds of London Technical College, Leonard-street, City-road, E.C.
1901. \*Morison, James. Perth.
1883. \*MORLEY, HENRY FORSTER, M.A., D.Sc., F.C.S. 5 Lyndhurst-road, Hampstead, N.W.
1906. †Morrell, H. R. Scarcroft-road, York.
1896. \*Morrell, Dr. R. S. Tor Lodge, Tottenhall Wood, Wolverhampton.
1892. †MORRIS, Sir DANIEL, K.C.M.G., D.Sc., F.L.S. (Council, 1915- ) 14 Crabton-close, Boscombe, Hants.

Year of  
Election.

1915. \*Morris, H. N. Gorton Brook Chemical Works, Manchester.  
 1896. \*Morris, J. T. 36 Cumberland-mansions, Seymour-place, W.  
 1880. †Morris, James. 23 Brynymor-crescent, Swansea.  
 1907. †Morris, Colonel Sir W. G., K.C.M.G. Care of Messrs. Cox & Co.,  
 16 Charing Cross, W.C.  
 1899. \*MORROW, Major JOHN, M.Sc., D.Eng. Armstrong College, New-  
 castle-upon-Tyne.  
 1909. †Morse, Morton F. Wellington-crescent, Winnipeg, Canada.  
 1886. \*Morton, P. F. 15 Ashley-place, Westminster, S.W.  
 1896. \*MORTON, WILLIAM B., M.A., Professor of Natural Philosophy in  
 Queen's University, Belfast.  
 1913. §Mosely, Alfred. West Lodge, Barnet.  
 1908. †Moss, C. E., D.Sc. Botany School, Cambridge.  
 1876. §MOSS, RICHARD JACKSON, F.I.C., M.R.I.A. Royal Dublin Society,  
 and St. Aubyn's, Ballybrack, Co. Dublin.  
 1892. \*Mostyn, S. G., M.A., M.B. Health Office, Houndgate, Darlington.  
 1913. †Mott, Dr. F. W., F.R.S. 25 Nottingham-place, W.  
 1913. †Mottram, V. H. 256 Lordship-lane, East Dulwich, S.E.  
 1912. \*Moulton, J. C. Sarawak Museum, Sarawak.  
 1878. \*MOULTON, The Right Hon. Lord Justice, K.C.B., M.A., K.C.,  
 F.R.S. 57 Onslow-square, S.W.  
 1905. \*Moysey, Miss E. L. Pitcroft, Guildford, Surrey.  
 1911. \*Moysey, Lewis, B.A., M.B. St. Moritz, Ilkeston-road, Nottingham.  
 1912. †Mudie, Robert Francis. 6 Fintry-place, Broughty Ferry.  
 1902. †Muir, Arthur H. 7 Donegall-square West, Belfast.  
 1907. \*Muir, Professor James. 31 Burnbank-gardens, Glasgow.  
 1915. †Muir, Ramsay. 140 Plymouth-grove, Manchester.  
 1909. †Muir, Robert R. Grain Exchange-building, Winnipeg, Canada.  
 1912. §Muir, Thomas Scott. 19 Seton-place, Edinburgh.  
 1904. †Muir, William, I.S.O. Rowallan, Newton Stewart, N.B.  
 1872. \*MUIRHEAD, ALEXANDER, D.Sc., F.R.S., F.C.S. 12 Carteret-street,  
 Queen Anne's Gate, Westminster, S.W.  
 1913. †Muirhead, Professor J. H., LL.D. The Rowans, Balsall Common,  
 near Coventry.  
 1905. \*Muirhead, James M. P., F.R.S.E. The Dunlop Rubber Co., Ltd.,  
 Aston Cross, Birmingham.  
 1876. \*Muirhead, Robert Franklin, B.A., D.Sc. 64 Great George-street,  
 Hillhead, Glasgow.  
 1902. †Mullan, James. Castlerock, Co. Derry.  
 1915. §Mullen, B. H. Salford Museum, Peel Park, Salford.  
 1904. †Mullinger, J. Bass, M.A. 1 Bene't-place, Cambridge.  
 1911. †Mumby, Dr. B. H. Borough Asylum, Milton, Portsmouth.  
 1898. †Mumford, C. E. Cross Roads House, Bouverie-road, Folkestone.  
 1901. \*Munby, Alan E. 44 Downshire-hill, Hampstead, N.W.  
 1906. †Munby, Frederick J. Whixley, York.  
 1904. †Munro, A. Queens' College, Cambridge.  
 1909. †Munro, George. 188 Roslyn-road, Winnipeg, Canada.  
 1883. \*MUNRO, ROBERT, M.A., M.D., LL.D. (Pres. H, 1893.) Elmbank,  
 Largs, Ayrshire, N.B.  
 1909. †Munson, J. H., K.C. Wellington-crescent, Winnipeg, Canada.  
 1914. \*Murchison, Roderick. Melbourne-mansions, Collins-street, Mel-  
 bourne.  
 1911. †Murdoch, W. H. F., B.Sc. 14 Howitt-road, Hampstead, N.W.  
 1909. §Murphy, A. J. Vanguard Manufacturing Co., Dorrington-street,  
 Leeds.  
 1908. †Murphy, Leonard. 156 Richmond-road, Dublin.  
 1908. †MURPHY, WILLIAM M., J.P. Dartry, Dublin.

- Year of Election.
1905. †Murray, Charles F. K., M.D. Kenilworth House, Kenilworth, Cape Colony.
1903. §Murray, Colonel J. D. Mytholmroyd, Wigan.
1916. §Murray, Miss Jessie, M.B. 14 Endsleigh-street, W.C.
1914. †Murray, John. Tullibardin New Farm, Brisbane, Australia.
1915. †Murray, Miss M. A. Edwards Library, University College, Gower-street, W.C.
1892. †Murray, T. S., D.Sc. 27 Shamrock-street, Dundee.
1909. †Murray, W. C. University of Saskatchewan, Saskatoon, Saskatchewan, Canada.
1906. †Musgrove, Mrs. Edith M. S., D.Sc. The Woodlands, Silverdale, Lancashire.
1912. \*Musgrove, James, M.D., Professor of Anatomy in the University of St. Andrews, N.B.
1870. \*Muspratt, Edward Knowles. Seaforth Hall, near Liverpool.
1906. †Myddelton-Gavey, E. H., J.P., F.R.G.S. Stanton Prior, Meads, Eastbourne.
1913. †Myddelton-Gavey, Miss Violet. Stanton Prior, Meads, Eastbourne.
1902. †Myddleton, Alfred. 62 Duncairn-street, Belfast.
1902. \*Myers, Charles S., M.A., M.D. Great Shelford, Cambridge.
1909. \*Myers, Henry. The Long House, Leatherhead.
1906. †Myers, Jesse A. Glengarth, Walker-road, Harrogate.
1915. §Myers, William. 7 Station-road, Chcadle Hulme.
1890. \*MYRES, JOHN L., M.A., F.S.A. (Pres. H, 1909 ; Council, 1909-16), Wykeham Professor of Ancient History in the University of Oxford. 101 Banbury-road, Oxford.
1914. \*Myres, Miles Claude. 101 Banbury-road, Oxford.
1886. †NAGEL, D. H., M.A. (Local Sec. 1894.) Trinity College, Oxford.
1890. †Nalder, Francis Henry. 34 Queen-street, E.C.
1908. †Nally, T. H. Temple Hill, Terenure, Co. Dublin.
1908. \*Neal, Mrs. E. M. 10 Meadway, Hampstead Garden Suburb, N.W.
1909. †Neild, Frederic, M.D. Mount Pleasant House, Tunbridge Wells.
1883. \*Neild, Theodore, M.A. Grange Court, Leominster.
1914. †Nelson, Miss Edith A., M.A., M.Sc. 131 Williams-road, East Prahran, Victoria.
1914. \*Nettlefold, J. S. Winterbourne, Edgbaston Park-road, Birmingham.
1914. †Nettlefold, Miss. Winterbourne, Edgbaston Park-road, Birmingham.
1866. \*Nevill, The Right Rev. Samuel Tarratt, D.D., F.L.S., Bishop of Dunedin, New Zealand.
1889. \*NEWALL, H. FRANK, M.A., F.R.S., F.R.A.S., Professor of Astrophysics in the University of Cambridge. Madingley Rise, Cambridge.
1912. †Newberry, Percy E., M.A., Professor of Egyptology in the University of Liverpool. Oldbury Place, Ightham, Kent.
1916. §Newbiggin, Henry T. 3 St. Nicholas-buildings, Newcastle-on-Tyne.
1901. †Newbiggin, Miss Marion, D.Sc. Royal Scottish Geographical Society, Edinburgh.
1901. †Newman, F. H. Tullie House, Carlisle.
1913. †Newman, L. F. 2 Warkworth-street, Cambridge.
1889. †Newstead, A. H. L., B.A. 38 Green-street, Bethnal Green, N.E.
1912. \*Newton, Arthur U. University College, Gower-street, W.C.
1892. †NEWTON, E. T., F.R.S., F.G.S. Florence House, Willow Bridge-road, Canonbury, N.

Year of  
Election.

1914. §Newton, R. Bullen, F.G.S. British Museum (Natural History), South Kensington, S.W.
1914. †Nicholls, Dr. E. Brooke. 174 Victoria-street, North Melbourne.
1914. †Nicholls, Professor G. E. King's College, Strand, W.C.
1908. †Nicholls, W. A. 11 Vernham-road, Plumstead, Kent.
1908. †Nichols, Albert Russell. 30 Grosvenor-square, Rathmines, Co. Dublin.
1908. §Nicholson, J. W., M.A., D.Sc., Professor of Mathematics in King's College, Strand, W.C.
1884. †NICHOLSON, JOSEPH S., M.A., D.Sc. (Pres. F, 1893), Professor of Political Economy in the University of Edinburgh.
1911. †Nicol, J. C., M.A. The Grammar School, Portsmouth.
1916. §Nisbet, E. T. 26 Beverley-gardens, Cullercoats.
1915. †Niven, James. Civic Buildings, 1 Mount-street, Manchester.
1908. †NIXON, The Right Hon. Sir CHRISTOPHER, Bart., M.D., LL.D., D.L. 2 Merrion-square, Dublin.
1916. §NOBLE, J. H. B. Sandhoe, Hexham, Northumberland.
1863. §NORMAN, Rev. Canon ALFRED MERLE, M.A., D.C.L., LL.D., F.R.S., F.L.S. The Red House, Berkhamsted.
1888. †Norman, George. 12 Brock-street, Bath.
1913. §Norman, Sir Henry, Bart., M.P. The Corner House, Cowley-street, S.W.
1912. †Norrie, Robert. University College, Dundee.
1913. †Norris, F. Edward. Seismograph Station, Hill View, Woodbridge Hill, Guildford.
1916. §NORTHUMBERLAND, The Duke of, K.G., F.R.S. 2 Grosvenor-place, S.W.
1894. §NOTCUTT, S. A., LL.M., B.A., B.Sc. (Local Sec. 1895.) Constitution-hill, Ipswich.
1909. †Nugent, F. S. 81 Notre Dame-avenue, Winnipeg, Canada.
1910. §Nunn, T. Percy, M.A., D.Sc., Professor of Education in the University of London. London Day Training College, Southampton-row, W.C.
1915. †Nuttall, Harry, M.P. Bank of England-chambers, Manchester.
1913. §Nuttall, T. E., M.D. Middleton, Huncoat, Accrington.
1912. †Nuttall, W. H. Cooper Laboratory for Economic Research, Rickmansworth-road, Watford.
1908. †Nutting, Sir John, Bart. St. Helen's, Co. Dublin.
1898. \*O'Brien, Neville Forth. Greywell House, Woking.
1908. †O'Carroll, Joseph, M.D. 43 Merrion-square East, Dublin.
1913. §Oekenden, Maurice A., F.G.S. Oil Well Supply Company, Dashwood House, New Broad-street, E.C.
1883. †Odgers, William Blake, M.A., LL.D., K.C. 15 Old-square, Lincoln's Inn, W.C.
1910. \*Odling, Marmaduke, M.A., F.G.S. Geological Department, The University, Leeds.
1858. \*ODLING, WILLIAM, M.B., F.R.S., V.P.C.S. (Pres. B, 1864; Council, 1865-70.) 15 Norham-gardens, Oxford.
1911. \*O'DONOGHUE, CHARLES H., D.Sc. University College, Gower-street, W.C.
1908. §O'Farrell, Thomas A., J.P. 30 Lansdowne-road, Dublin.
1915. †Ogden, C. K., M.A. Magdalene College, Cambridge.
1902. †Ogden, James Neal. Claremont, Heaton Chapel, Stockport.
1913. †Ogilvie, A. G. 15 Evelyn-gardens, S.W.
1876. †Ogilvie, Campbell P. Lawford-place, Manningtree.
1914. †Ogilvie, Mrs. Campbell P. Lawford-place, Manningtree.



Year of  
Election.

1885. †OGILVIE, F. GRANT, C.B., M.A., B.Sc., F.R.S.E. (Local Sec. 1892.) Board of Education, S.W.
1912. §Ogilvy, J. W. 18 Bloomsbury-square, W.C.
1905. \*Oke, Alfred William, B.A., LL.M., F.G.S., F.L.S. 32 Denmark-villas, Hove, Brighton.
1905. §Okell, Samuel, F.R.A.S. Overley, Langham-road, Bowdon, Cheshire.
1908. §Oldham, Charles Hubert, B.A., B.L., Professor of Commerce in the National University of Ireland. 5 Victoria-terrace, Rathgar, Dublin.
1892. †OLDHAM, H. YULE, M.A., F.R.G.S., Lecturer in Geography in the University of Cambridge. King's College, Cambridge.
1893. \*OLDHAM, R. D., F.R.S., F.G.S. 1 Broomfield-road, Kew, Surrey.
1912. §O'Leary, Rev. William, S.J. Rathfarnham Castle, Co. Dublin.
1914. †Oliver, Calder E. Manor-street, Brighton, Victoria.
1887. †OLIVER, F. W., D.Sc., F.R.S., F.L.S. (Pres. K, 1906). Professor of Botany in University College, London, W.C.
1914. §Oliver, H. G., C.E. Lara, Victoria, Australia.
1889. §Oliver, Professor Sir Thomas, M.D. 7 Ellison-placo, Newcastle-upon-Tyne.
1882. §OLSEN, O. T., D.Sc., F.L.S., F.R.A.S., F.R.G.S. 116 St. Andrew's terrace, Grimsby.
1908. †O'Neill, Rev. G., M.A. University College, St. Stephen's Green, Dublin.
1902. †O'Neill, Henry, M.D. 6 College-square East, Belfast.
1913. †Orange, J. A. General Electric Company, Schenectady, New York, U.S.A.
1916. §Orde, Edwin L. Walker Shipyard, Newcastle-on-Tyne.
1905. †O'Reilly, Patrick Joseph. 7 North Earl-street, Dublin.
1884. \*Orpen, Rev. T. H., M.A. Mark Ash, Abinger Common, Dorking.
1901. †Orr, Alexander Stewart. 10 Medows-street, Bombay, India.
1909. †Orr, John B. Crossacres, Woolton, Liverpool.
1908. \*Orr, William. Dungarvan, Co. Waterford.
1904. \*ORTON, K. J. P., M.A., Ph.D., Professor of Chemistry in University College, Bangor.
1915. §Orwin, C. S. 7 Marston Ferry-road, Oxford.
1910. \*OSBORN, T. G. B., M.Sc., Professor of Botany in the University of Adelaide, South Australia.
1901. †Osborne, Professor W. A., D.Sc. The University, Melbourne.
1908. †O'Shaughnessy, T. L. 64 Fitzwilliam-square, Dublin.
1887. †O'Shea, L. T., B.Sc. The University, Sheffield.
1884. †OSLER, Sir WILLIAM, Bart., M.D., LL.D., F.R.S., Regius Professor of Medicine in the University of Oxford. 13 Norham-gardens, Oxford.
1881. \*Ottewell, Alfred D. 14 Mill Hill-road, Derby.
1906. †Owen, Rev. E. C. St. Peter's School, York.
1903. \*Owen, Edwin, M.A. Terra Nova School, Birkdale, Lancashire.
1911. †Owens, J. S., M.D., Assoc.M.Inst.C.E. 47 Victoria-street, S.W.
1910. \*Oxley, A. E., M.A., D.Sc. Rose Hill View, Kimberworth-road, Rotherham.
1909. †Pace, F. W. 388 Wellington-crescent, Winnipeg, Canada.
1908. †Pack-Beresford, Denis, M.R.I.A. Fenagh House, Bagenalstown, Ireland.
1906. §Page, Carl D. Wyoming House, Aylesbury, Bucks.
1903. \*Page, Miss Ellen Iva. Turret House, Felpham, Sussex.

Year of  
Election.

1883. †Page, G. W. Bank House, Fakenham.
1913. †Paget, Sir Richard, Bart. Old Fallings Hall, Wolverhampton.
1911. §Paget, Stephen, M.A., F.R.C.S. 21 Ladbroke-square, W.
1912. †Pahic, Paul. 52 Albert Court, Kensington Gore, S.W.
1911. †Paine, H. Howard. 50 Stow-hill, Newport, Monmouthshire.
1870. \*PALGRAVE, Sir ROBERT HARRY INGLIS, F.R.S., F.S.S. (Pres. F., 1883.) Henstead Hall, Wrentham, Suffolk.
1896. †Pallis, Alexander. Tatoi, Aigburth-drive, Liverpool.
1878. \*Palmer, Joseph Edward. Royal Societies Club, St. James's-street, S.W.
1866. §Palmer, William. Waverley House, Waverley-street, Nottingham.
1915. \*Parker, A. The University, Birmingham.
1904. †PARKER, E. H., M.A. Thorneycreek, Herschel-road, Cambridge.
1909. §PARKER, M. A., B.Sc., F.C.S. (Local Sec. 1909), Professor of Chemistry in the University of Manitoba, Winnipeg, Canada.
1891. †PARKER, WILLIAM NEWTON, Ph.D., F.Z.S., Professor of Biology in University College, Cardiff.
1899. \*Parkin, John. Blaithwaite, Carlisle.
1905. \*Parkin, Thomas. Blaithwaite, Carlisle.
1906. §Parkin, Thomas, M.A., F.L.S., F.Z.S., F.R.G.S. Fairseat, High Wickham, Hastings.
1879. \*Parkin, William. Broomhill House, Watson-road, Sheffield.
1911. †Parks, Dr. G. J. 18 Cavendish-road, Southsea.
1913. †Parry, Edward, M.Inst.C.E. Rossmore, Leamington.
1903. §Parry, Joseph, M.Inst.C.E. Woodbury, Waterloo, near Liverpool.
1908. †Parry, W. K., M.Inst.C.E. 6 Charlemont-terrace, Kingstown, Dublin.
1878. †PARSONS, Hon. Sir C. A., K.C.B., M.A., Sc.D., F.R.S., M.Inst.C.E. (PRESIDENT ELECT; Pres. G., 1904.) 1 Upper Brook-street, W.
1904. †Parsons, Professor F. G. St. Thomas's Hospital, S.E.
1905. \*Parsons, Hon. Geoffrey L. Worthing House, Basingstoke, Hants.
1898. \*Partridge, Miss Josephine M. Pioneer Club, 9 Park-place, St. James's, S.W.
1887. †PATERSON, A. M., M.D., Professor of Anatomy in the University of Liverpool.
1908. †Paterson, M., LL.D. 7 Halton-place, Edinburgh.
1909. †Paterson, William. Ottawa, Canada.
1897. †Paton, D. Noël, M.D., F.R.S., Professor of Physiology in the University of Glasgow.
1883. \*Paton, Rev. Henry, M.A. Elmswood, Bonnington-road, Peebles.
1884. \*Paton, Hugh. Box 2646, Montreal, Canada.
1913. §Patrick, Joseph A., J.P. North Cliff, King's Heath, Birmingham.
1908. §PATTEN, C. J., M.A., M.D., Sc.D., Professor of Anatomy in the University of Sheffield.
1874. †Patterson, W. H., M.R.I.A. 26 High-street, Belfast.
1913. †Patterson, W. Hamilton, M.Sc. The Monksferry Laboratory, Birkenhead.
1913. \*Pattin, Harry Cooper, M.A., M.D. King-street House, Norwich.
1879. \*Patzer, F. R. Clayton Lodge, Newcastle, Staffordshire.
1887. \*Paxman, James. Standard Iron Works, Colchester.
1887. \*Payne, Miss Edith Annie. Hatchlands, Cuckfield, Hayward's Heath.
1914. \*Payne, Professor Henry, M.Inst.C.E. The University, Melbourne.
1888. \*Paynter, J. B. Hendford Manor, Yeovil.
1876. †Peace, G. H., M.Inst.C.E. The Beeches, Charcoal-road, Dunham Massey, Altrincham.
1906. †Peace, Miss Gertrude. 39 Westbourne-road, Sheffield.

Year of  
Election.

1885. †PEACH, B. N., LL.D., F.R.S., F.R.S.E., F.G.S. (Pres. C, 1912.)  
Geological Survey Office, George-square, Edinburgh.
1911. §Peake, Harold J. E. Westbrook House, Newbury.
1913. †Pear, T. H. Dunwood House, Withington, Manchester.
1886. \*Pearce, Mrs. Horace. Collingwood, Manby-road, Malvern.
1886. †Pearsall, H. D. Letchworth, Herts.
1883. †Pearson, Arthur A., C.M.G. Hillsborough, Heath-road, Petersfield,  
Hampshire.
1893. \*Pearson, Charles E. Hillcrest, Lowdham, Nottinghamshire.
1898. †Pearson, George. Bank-chambers, Baldwin-street, Bristol.
1883. †Pearson, Miss Helen E. Oakhurst, Birkdale, Southport.
1906. †Pearson, Dr. Joseph. The Museum, Colombo, Ceylon.
1904. †Pearson, Karl, M.A., F.R.S., Professor of Eugenics in the University  
of London. 7 Well-road, Hampstead, N.W.
1909. †Pearson, William. Wellington-crescent, Winnipeg, Canada.
- Peckitt, Henry. Carlton Husthwaite, Thirsk, Yorkshire.
1855. \*PECKOVER, Lord, LL.D., F.S.A., F.L.S., F.R.G.S. Bank House,  
Wisbech, Cambridgeshire.
1888. †Peckover, Miss Alexandrina. Bank House, Wisbech, Cambridge-  
shire.
1885. †Peddle, William, Ph.D., F.R.S.E., Professor of Natural Philosophy  
in University College, Dundee.
1884. †Peebles, W. E. 9 North Frederick-street, Dublin.
1878. \*Peek, William. Villa des Jonquilles, Rue des Roses, Monte Carlo.
1901. \*Peel, Right Hon. Viscount. 52 Grosvenor-street, W.
1905. §Peirson, J. Waldie. P.O. Box 561, Johannesburg.
1915. †Pemberton, Granville. 49 Acresfield-road, Pendleton.
1905. †Pemberton, Gustavus M. P.O. Box 93, Johannesburg.
1916. §Pemberton, J. S. G. Belmont, Durham.
1887. †PENDLEBURY, WILLIAM H., M.A., F.C.S. (*Local Sec.* 1899.)  
*Woodford House, Mountfields, Shrewsbury.*
1894. †Pengelly, Miss. Lamorna, Torquay.
1896. †Pennant, P. P. Nantlys, St. Asaph.
1898. †Percival, Francis W., M.A., F.R.G.S. 1 Chesham-street, S.W.
1908. †Percival, Professor John, M.A. University College, Reading.
1905. †Péringuey, L., D.Sc., F.Z.S. South African Museum, Cape  
Town.
1894. †PERKIN, A. G., F.R.S., F.R.S.E., F.C.S., F.I.C. Grosvenor Lodge,  
Grosvenor-road, Leeds.
1902. \*Perkin, F. Mollwo, Ph.D. 199 Piccadilly, W.
1884. †PERKIN, WILLIAM HENRY, LL.D., Ph.D., F.R.S., F.R.S.E. (Pres.  
B, 1900; Council, 1901-07), Waynflete Professor of Chemistry  
in the University of Oxford. 5 Charlbury-road, Oxford.
1864. \*Perkins, V. R. Wotton-under-Edge, Gloucestershire.
1898. \*Perman, E. P., D.Sc. University College, Cardiff.
1909. †Perry, Rev. Professor E. Guthrie. 246 Kennedy-street, Winnipeg,  
Canada.
1874. \*PERRY, Professor JOHN, M.E., D.Sc., LL.D., F.R.S. (GENERAL  
TREASURER, 1904- ; Pres. G, 1902; Pres. L, 1914; Coun-  
cil, 1901-04.) British Association, Burlington House, Lon-  
don, W.
1913. †Perry, W. J. 7 York-view, Pocklington, Yorkshire.
1904. †Pertz, Miss D. F. M. 2 Cranmer-road, Cambridge.
1900. \*PETAVEL, J. E., D.Sc., F.R.S., Professor of Engineering in the  
University of Manchester.
1914. \*Peters, Thomas. Burrinjuck via Goondah, N.S.W.
1901. †Pethybridge, G. H., Ph.D. Royal College of Science, Dublin.

Year of  
Election.

1910. \*Petrescu, Captain Dimitrie, R.A., M.Eng. Scoala Superiora de Messern, Bucharest, Rumania.
1895. †PETRIE, W. M. FLINDERS, D.C.L., F.R.S. (Pres. H, 1895), Professor of Egyptology in University College, W.C.
1871. \*Peyton, John E. H., F.R.A.S., F.G.S. Vale House, St. Helier, Jersey.
1886. †Phelps, Lieut.-General A. 23 Augustus-road, Edgbaston, Birmingham.
1911. †Philip, Alexander. Union Bank-buildings, Brechin.
1896. †Philip, G. Hornend, Pinner, Middlesex.
1903. †Philip, James C. 20 Westfield-terrace, Aberdeen.
1853. \*Philips, Rev. Edward. Hollington, Uttoxeter, Staffordshire.
1877. §Philips, T. Wishart. Elizabeth Lodge, Crescent-road, South Woodford, Essex.
1863. †PHILLIPSON, Sir G. H., M.D., D.C.L. 7 Eldon-square, Newcastle-on-Tyne.
1905. †Phillimore, Miss C. M. Shiplake House, Henley-on-Thames.
1899. \*Phillips, Charles E. S., F.R.S.E. Castle House, Shooter's Hill, Kent.
1910. \*Phillips, P. P., Ph.D., Professor of Chemistry in the Thomason Engineering College, Rurki, United Provinces, India.
1890. †PHILLIPS, R. W., M.A., D.Sc., F.L.S., Professor of Botany in University College, Bangor. 2 Snowdon-villas, Bangor.
1909. \*Phillips, Richard. 15 Dogpole, Shrewsbury.
1915. †Phillips, Captain W. E. 7th Leinster Regiment, Kilworth Camp, Co. Cork.
1883. \*Pickard, Joseph William. Oatlands, Lancaster.
1901. §Pickard, Robert H., D.Sc. Billinge View, Blackburn.
1885. \*PICKERING, SPENCER P. U., M.A., F.R.S. Harpenden, Herts.
1907. †Pickles, A. R., M.A. Todmorden-road, Burnley.
1888. \*Pidgeon, W. R. Lynsted Lodge, St. Edmund's-terrace, Regent's Park, N.W.
1896. \*Pilkington, A. C. Rocklands, Rainhill, Lancashire.
1915. §Pilkington, Charles. The Headlands, Prestwich.
1905. †Pilling, Arnold. Royal Observatory, Cape Town.
1905. †Pim, Miss Gertrude. Charleville, Blackrock, Co. Dublin.
1911. †Pink, H. R. The Mount, Fareham, Hants.
1911. †Pink, Mrs. H. R. The Mount, Fareham, Hants.
1911. †Pink, Mrs. J. E. The Homestead, Eastern-parade, Southsea.
1908. \*Pio, Professor D. A. 14 Leverton-street, Kentish Town, N.W.
1908. †Pirrie, The Right Hon. Lord, LL.D., M.Inst.C.E. Downshire House, Belgrave-square, S.W.
1909. †Pitblado, Isaac, K.C. 91 Balmoral-place, Winnipeg, Canada.
1893. \*PITT, WALTER, M.Inst.C.E. 3 Lansdown-grove, Bath.
1900. \*Platts, Walter. Morningside, Scarborough.
1911. \*Plinimer, R. H. A. Rapulf-road, Hampstead, N.W.
1915. §Plummer, Professor H. C., Royal Astronomer of Ireland. Dunsink Observatory, Co. Dublin.
1898. †Plummer, W. E., M.A., F.R.A.S. The Observatory, Bidston, Birkenhead.
1916. §Plummer, Sir W. R. 4 Queen's-square, Newcastle-on-Tyne.
1908. †Plunkett, Colonel G. T., C.B. Belvedere Lodge, Wimbledon, S.W.
1907. \*PLUNKETT, Right Hon. Sir HORACE, K.C.V.O., M.A., F.R.S. Kilteragh, Foxrock, Co. Dublin.
1900. \*Pocklington, H. Cabourn, M.A., D.Sc., F.R.S. 5 Wellclose-place, Leeds.
1913. †Pocock, R. J. St. Aidan's, 170 Eglinton-road, Woolwich, S.E.

Year of  
Election.

1916. §Pole, Miss H. J. Lydgate, Boar's Hill, Oxford.  
 1914. †Pollock, Professor J. A., D.Sc., F.R.S. The University, Sydney, N.S.W.  
 1908. †Pollok, James H., D.Sc. 6 St. James's-terrace, Clonshea, Dublin.  
 1906. \*Pontifex, Miss Catherine E. 7 Hurlingham-court, Fulham, S.W.  
 1891. †Poutypridd, Lord. Pen-y-lan, Cardiff.  
 1911. †Poore, Major-General F. H. 1 St. Helen's-parade, Southsea.  
 1907. §Pope, Alfred, F.S.A. South Court, Dorchester.  
 1900. \*POPE, W. J., M.A., LL.D., F.R.S. (Pres. B, 1914), Professor of Chemistry in the University of Cambridge. Chemical Laboratory, The University, Cambridge.  
 1892. †Popplewell, W. C., M.Sc., Assoc.M.Inst.C.E. Bowden-lane, Marple, Cheshire.  
 1901. §PORTER, ALFRED W., B.Sc., F.R.S. 87 Parliament Hill-mansions, Lissenden-gardens, N.W.  
 1905. §PORTER, J. B., D.Sc., M.Inst.C.E., Professor of Mining in the McGill University, Montreal, Canada.  
 1905. †Porter, Mrs. McGill University, Montreal, Canada.  
 1911. §Porter, Mrs. W. H., M.Sc. 3 Brighton-villas, Western-road, Cork.  
 1883. †POTTER, M. C., M.A., F.L.S., Professor of Botany in the Armstrong College, Newcastle-upon-Tyne. 13 Highbury, Newcastle-upon-Tyne.  
 1906. †Potter-Kirby, Alderman George. Clifton Lawn, York.  
 1907. †Potts, F. A. University Museum of Zoology, Cambridge.  
 1908. \*Potts, George, Ph.D., M.Sc. 91 Park-road, Bloemfontein, South Africa.  
 1886. \*POULTON, EDWARD B., M.A., F.R.S., F.L.S., F.G.S., F.Z.S. (Pres. D, 1896; Council, 1895-1901, 1905-12), Professor of Zoology in the University of Oxford. Wykeham House, Banbury-road, Oxford.  
 1905. †Poulton, Mrs. Wykeham House, Banbury-road, Oxford.  
 1913. †Poulton, Miss. Wykeham House, Banbury-road, Oxford.  
 1898. \*Poulton, Edward Palmer, M.A. Wykeham Cottage, Woldingham, Surrey.  
 1894. \*Powell, Sir Richard Douglas, Bart., M.D. 11B Portland-place, W.  
 1887. §Pownall, George H. 20 Birchin-lane, E.C.  
 1913. †Poynting, Mrs. J. H. 10 Ampton-road, Edgbaston, Birmingham.  
 1908. †PRAEGER, R. LLOYD, B.A., M.R.I.A. Lisnamae, Rathgar, Dublin.  
 1907. \*PRAIN, Lieut.-Col. Sir DAVID, C.I.E., C.M.G., M.B., F.R.S. (Pres. K, 1909; Council, 1907-14.) Royal Gardens, Kew.  
 1884. \*Pranker, A. A., D.C.L. 66 Banbury-road, Oxford.  
 1913. \*Pranker, Miss Theodora Lisle. 25 Hornsey Lane-gardens, N.  
 1888. \*Preece, W. Llewellyn, M.Inst.C.E. 8 Queen Anne's-gate, S.W.  
 1904. §Prentice, Mrs. Manning. 27 Baldock-road, Letchworth.  
 1892. †Prentice, Thomas. Willow Park, Greenock.  
 1906. †Pressly, D. L. Coney-street, York.  
 1889. †Preston, Alfred Eley, M.Inst.C.E., F.G.S. 14 The Exchange, Bradford, Yorkshire.  
 1914. †Preston, C. Payne. Australian Distillery Co., Byrne-street, South Melbourne.  
 1914. †Preston, Miss E. W. 153 Barry-street, Carlton, Victoria.  
 1903. §Price, Edward E. Oaklands, Oaklands-road, Bromley, Kent.  
 1888. †PRICE, L. L. F. R., M.A., F.S.S. (Pres. F, 1895; Council, 1898-1904.) Oriol College, Oxford.  
 1785. \*Price, Rees. Walnuts, Broadway, Worcestershire.  
 1913. §Price, T. Slater. Municipal Technical School, Suffolk-street, Birmingham.

Year of  
Election.

1897. \*PRICE, W. A., M.A. The Elms, Park-road, Teddington.  
 1914. †Priestley, Professor H. J. Edale, River-terrace, Kangaroo Point, Brisbane, Australia.  
 1908. §PRIESTLEY, J. H., B.Sc., Professor of Botany in the University of Leeds.  
 1909. \*Prince, Professor E. E., LL.D., Dominion Commissioner of Fisheries. 206 O'Connor-street, Ottawa, Canada.  
 1889. \*Pritchard, Eric Law, M.D., M.R.C.S. 70 Fairhazel-gardens, South Hampstead, N.W.  
 1876. \*PRITCHARD, URBAN, M.D., F.R.C.S. 26 Wimpole-street, W.  
 1881. §Procter, John William. Minster Hill, Huttons Ambo, York.  
 1884. \*Proudfoot, Alexander, M.D. Care of E. C. S. Scholefield, Esq., Provincial Librarian, Victoria, B.C., Canada.  
 1879. \*Prouse, Oswald Milton, F.G.S. Alvington, Ilfracombe.  
 1872. \*Pryor, M. Robert. Weston Park, Stevenage, Herts.  
 1883. \*Pullar, Rufus D., F.C.S. Brahan, Perth.  
 1903. †Pullen-Burry, Miss. Lyceum Club, 128 Piccadilly, W.  
 1904. †Punnett, R. C., M.A., F.R.S., Professor of Biology in the University of Cambridge. Caius College, Cambridge.  
 1913. †Purser, G. *Leslie. Gwynfa, Selly Oak, Birmingham.*  
 1913. †Purser, John, M.Sc. The University, Edgbaston, Birmingham.  
 1884. \*Purves, W. Laidlaw. 20 Stratford-place, Oxford-street, W.  
 1911. †Purvis, J. E. Corpus Christi College, Oxford.  
 1912. †Pycraft, Dr. W. P. British Museum (Natural History), Cromwell-road, S.W.  
 1898. \*Pye, Miss E. St. Mary's Hall, Rochester.  
 1883. §Pye-Smith, Arnold. 32 Queen Victoria-street, E.C.  
 1883. †Pye-Smith, Mrs. 32 Queen Victoria-street, E.C.  
 1879. †Pye-Smith, R. J. 450 Glossop-road, Sheffield.  
 1911. †Pye-Smith, Mrs. R. J. 450 Glossop-road, Sheffield.  
 1893. †Quick, James. 22 Bouverie-road West, Folkestone.  
 1906. \*Quiggin, Mrs. A. Hingston. Great Shelford, Cambridge.  
 1879. †Radford, R. Heber. 15 St. James's-row, Sheffield.  
 1911. §Rae, John T. National Temperance League, Paternoster House, Paternoster-row, E.C.  
 1887. \*Ragdale, John Rowland. The Beeches, Stand, near Manchester.  
 1913. §Railing, Dr. A. H., B.Sc. The General Electric Co., Ltd., Witton, Birmingham.  
 1898. \*Raisin, Miss Catherine A., D.Sc. Bedford College, Regent's Park, N.W.  
 1896. \*RAMAGE, HUGH, M.A. The Technical Institute, Norwich.  
 1894. \*RAMBAUT, ARTHUR A., M.A., D.Sc., F.R.S., F.R.A.S., M.R.I.A. Radcliffe Observatory, Oxford.  
 1908. †Rambaut, Mrs. Radcliffe Observatory, Oxford.  
 1912. †Ramsay, Colonel R. G. Wardlaw. Whitehill, Rosewell, Midlothian.  
 1883. †Ramsay, Lady. Beechcroft, Hazlemere, High Wycombe.  
 1915. †Ramsbottom, J. 61 Ennerdale-road, Richmond, Surrey.  
 1914. †Ramsbottom, J. W. 23 Rosebery-crescent, Newcastle-on-Tyne.  
 1913. †Ramsden, William. Blacker-road, Huddersfield.  
 1907. †Rankine, A. O., D.Sc. 68 Courtfield-gardens, West Ealing, W.  
 1868. \*Ransom, Edwin, F.R.G.S. 24 Ashburnham-road, Bedford.

Year of  
Election.

1861. †RANSOME, ARTHUR, M.A., M.D., F.R.S. (Local Sec. 1861.)  
Sunnyhurst, Dean Park, Bournemouth.
1903. †Rastall, R. H. Christ's College, Cambridge.
1914. †Rathbone, Herbert R. 15 Lord-street, Liverpool.
1892. \*Rathbone, Miss May. Backwood, Neston, Cheshire.
1913. †Raw, Frank, B.Sc., F.G.S. The University, Edmund-street,  
Birmingham.
1914. †Rawes-Whitell, H. *Manchester Hall, 183 Elizabeth-street,  
Sydney, N.S.W.*
1908. \*Raworth, Alexander. St. John's Manor, Jersey.
1915. †Rawson, Christopher. 33 Manley-road, Manchester.
1905. †Rawson, Colonel Herbert E., C.B., R.E., F.R.G.S. Home Close,  
Heronsgate, Herts.
1868. \*RAYLEIGH, The Right Hon. Lord, O.M., M.A., D.C.L., LL.D.,  
F.R.S., F.R.A.S., F.R.G.S. (PRESIDENT, 1884; TRUSTEE,  
1883-; Pres. A, 1882; Council, 1878-83), Professor of  
Natural Philosophy in the Royal Institution, London. Terling  
Place, Witham, Essex.
1883. \*Rayne, Charles A., M.D., M.R.C.S. St. Mary's Gate, Lancaster.
1912. §Rayner, Miss M. C., D.Sc. University College, Reading.
1897. \*Rayner, Edwin Hartree, M.A. 40 Gloucester-road, Teddington,  
Middlesex.
1907. †Rea, Carleton, B.C.L. 34 Foregate-street, Worcester.
1913. §Read, Carveth, M.A. 73 Kensington Gardens-square, W.
1896. \*READ, Sir CHARLES H., LL.D., F.S.A. (Pres. H, 1899.) British  
Museum, W.C.
1913. §Reade, Charles C. Attorney General's Office, Adelaide.
1914. †Reade, Mrs. C. C. Attorney General's Office, Adelaide.
1884. †Readman, J. B., D.Sc., F.R.S.E. Belmont, Hereford.
1890. \*Redwood, Sir Boverton, Bart., D.Sc., F.R.S.E., F.C.S. The  
Cloisters, 18 Avenue-road, Regent's Park, N.W.
1915. †Reed, H. A. The Red House, Bowdon.
1916. \*Reed, Thomas, C.A. 1 High West-street, Gateshead-on-Tyne.
1891. \*Reed, Thomas A. Bute Docks, Cardiff.
1894. \*Rees, Edmund S. G. Dunscair, Oaken, near Wolverhampton.
1903. †REEVES, E. A., F.R.G.S. (Pres. E, 1916.) Hillside, Reigate-  
road, Reigate.
1911. †REEVES, Hon. W. PEMBER. (Pres. F, 1911.) London School of  
Economics, Clare Market, W.C.
1906. \*Reichel, Sir Harry R., M.A., LL.D., Principal of University  
College, Bangor. Penrallt, Bangor, North Wales.
1910. \*Reid, Alfred, M.B., M.R.C.S. The Cranes, Tooting, S.W.
1901. \*Reid, Andrew T. Auchterarder House, Auchterarder, Perthshire.
1904. †Reid, Arthur H. 30 Welbeck-street, W.
1881. §Reid, Arthur S., M.A., F.G.S. Trinity College, Glonalmund, N.B.
1903. \*Reid, Mrs. E. M., B.Sc. One Acre, Milford-on-Sea, Hants.
1892. †REID, E. WAYMOUTH, B.A., M.B., F.R.S., Professor of Physiology  
in University College, Dundee.
1908. †REID, GEORGE ARCHDALL, M.B., C.M., F.R.S.E. 9 Victoria-road  
South, Southsea.
1901. \*Reid, Hugh. Belmont, Springburn, Glasgow.
1901. †Reid, John. 7 Park-terrace, Glasgow.
1909. †Reid, John Young. 329 Wellington-crescent, Winnipeg, Canada.
1904. †Reid, P. J. Marton Moor End, Nunthorpe, R.S.O., Yorkshire.
1912. §Reid, Professor R. W., M.D. 37 Albyn-place, Aberdeen.
1897. †Reid, T. Whitehead, M.D. St. George's House, Canterbury.
1892. †Reid, Thomas. Municipal Technical School, Birmingham.

Year of  
Election.

1887. \*Reid, Walter Francis. Fieldside, Addlestone, Surrey.  
 1912. §Reinheimer, Hermann. 43 King Charles-road, Surbiton.  
 1875. ‡REINOLD, A. W., C.B., M.A., F.R.S. (Council, 1890-95.) 3 Lennox-mansions, Southsea.  
 1894. †Rendall, Rev. G. H., M.A., Litt.D. Charterhouse, Godalming.  
 1891. \*Rendell, Rev. James Robson, B.A. Whinside, Whalley-road, Accrington.  
 1903. \*RENDLE, Dr. A. B., M.A., F.R.S., F.L.S. (Pres. K, 1916.) 28 Holmbush-road, Putney, S.W.  
 1914. †Rennie, Professor E. H., M.A., D.Sc. The University, Adelaide, Australia.  
 1889. \*Rennie, George B. 20 Lowndes-street, S.W.  
 1906. †Rennie, John, D.Sc. Natural History Department, University of Aberdeen.  
 1916. §Renouf, Louis P. W. Bute Laboratory and Museum, Rothesay, Isle of Bute.  
 1905. \*Renton, James Hall. Rowfold Grange, Billingshurst, Sussex.  
 1912. †Rettie, Theodore. 10 Doune-terrace, Edinburgh.  
 1904. †REUNERT, THEODORE, M.Inst.C.E. P.O. Box 92, Johannesburg.  
 1912. †REW, Sir R. H., K.C.B. (Pres. M, 1915.) Board of Agriculture and Fisheries, 3 St. James's-square, S.W.  
 1905. §Reyersbach, Louis. Care of Messrs. Wernher, Beit, & Co., 1 London Wall-buildings, E.C.  
 1883. \*Reynolds, A. H. 271 Lord-street, Southport.  
 1913. †Reynolds, J. H. Low Wood, Harborne, Birmingham.  
 1871. †REYNOLDS, JAMES EMERSON, M.D., D.Sc., F.R.S., F.C.S., M.R.I.A. (Pres. B, 1893; Council, 1893-99.) 3 Inverness-gardens, W.  
 1900. \*Reynolds, Miss K. M. 8 Darnley-road, Notting Hill, W.  
 1906. †Reynolds, S. H., M.A., Sc.D., Professor of Geology in the University of Bristol.  
 1907. §Reynolds, W. G. Waterhouse. Birstall Holt, near Leicester.  
 1877. \*Riccardi, Dr. Paul, Secretary of the Society of Naturalists. Riva Muro 14, Modena, Italy.  
 1905. §Rich, Miss Florence, M.A. Granville School, Granville-road, Leicester.  
 1906. †Richards, Rev. A. W. 12 Bootham-terrace, York.  
 1914. †Richardson, A. E. V., M.A., B.Sc. Department of Agriculture, Melbourne.  
 1916. §Richardson, E. J. Anster, Grainger Park-road, Newcastle-on-Tyne.  
 1912. †Richardson, Harry, M.Inst.E.E. Electricity Supply Department, Dudhope Crescent-road, Dundee.  
 1889. †Richardson, Hugh, M.A. The Gables, Elswick-road, Newcastle-on-Tyne.  
 1884. \*Richardson, J. Clarke. Derwen Fawr, Swansea.  
 1916. §Richardson, Lawrence. Stoneham, Beech Grove-road, Newcastle-on-Tyne.  
 1896. \*Richardson, Nelson Moore, B.A., F.E.S. Montevideo, Chickerell, near Weymouth.  
 1901. \*Richardson, Owen Willans, M.A., D.Sc., F.R.S., Wheatstone Professor of Physics in King's College, London, W.C.  
 1914. \*Rideal, Eric K., B.A., Ph.D. 28 Victoria-street, S.W.  
 1883. \*RIDEAL, SAMUEL, D.Sc., F.C.S. 28 Victoria-street, S.W.  
 1911. †Ridgeway, Miss A. R. 45 West Cliff, Preston.  
 1902. §RIDGEWAY, WILLIAM, M.A., D.Litt., F.B.A. (Pres. H, 1908), Professor of Archæology in the University of Cambridge. Flendyshe, Fen Ditton, Cambridge.



Year of  
Election.

1913. §Ridler, Miss C. C. Coniston, Hunsdon-road, Torquay.  
 1894. †RIDLEY, E. P., F.G.S. (Local Sec. 1895.) Burwood, Westerfield-road, Ipswich.  
 1883. \*RIGG, Sir EDWARD, C.B., I.S.O., M.A. Malvera House, East Cliff, Ramsgate.  
 1892. †Rintoul, D., M.A. Clifton College, Bristol.  
 1912. §Rintoul, Miss L. J. Lahill, Largo, Fife.  
 1916. \*Rintoul, William. Lauriston, Ardrossan, Ayrshire.  
 1910. †Ripper, William, Professor of Engineering in the University of Sheffield.  
 1903. \*RIVERS, W. H. R., M.D., F.R.S. (Pres. H, 1911.) St. John's College, Cambridge.  
 1913. †RIVETT, A. C. D., B.A., Ph.D. (General Organising Secretary, 1914.) The University of Melbourne, Victoria.  
 1908. \*Roaf, Herbert E., M.D., D.Sc. 44 Rotherwick-road, Hendon, N.W.  
 1898. \*Robb, Alfred A., M.A., Ph.D. Lisnabreeny House, Belfast.  
 1914. †Robb, James Jenkins, M.D. Harlow, 19 Linden-road, Bournville, Birmingham.  
 1902. \*Roberts, Bruno. 30 St. George's-square, Regent's Park, N.W.  
 1887. \*Roberts, Evan. 27 Crescent-grove, Clapham Common, S.W.  
 1896. †Roberts, Thomas J. Ingleside, Park-road, Huyton, near Liverpool.  
 1913. †Robertson, Andrew. Engineering Laboratories, Victoria University, Manchester.  
 1916. §Robertson, G. S., M.Sc., F.C.S. East Anglian Institute of Agriculture, Chelmsford.  
 1897. †Robertson, Professor J. W., C.M.G., LL.D. The Macdonald College, St. Anne de Bellevue, Quebec, Canada.  
 1912. §Robertson, R. A., M.A., B.Sc., F.R.S.E., Lecturer on Botany in the University of St. Andrews.  
 1901. \*Robertson, Robert, B.Sc., M.Inst.C.E. Carnbooth, Carmunnock, Lanarkshire.  
 1913. \*Robins, Edward, M.Inst.C.E., F.R.G.S. Lobito, Angola, Portuguese South-West Africa.  
 1913. †Robinson, A. H., M.D. St. Mary's Infirmary, Highgate Hill, N.  
 1915. §Robinson, Arthur, Professor of Psychology in the University of Durham. Observatory House, Durham.  
 1886. \*Robinson, Charles Reece. 45 Durham-road, Sparkhill, Birmingham.  
 1909. †Robinson, E. M. 381 Main-street, Winnipeg, Canada.  
 1903. †Robinson, G. H. 1 Weld-road, Southport.  
 1902. †Robinson, Herbert C. Holmfield, Aigburth, Liverpool.  
 1911. †Robinson, J. J. 'West Sussex Gazette' Office, Arundel.  
 1902. †Robinson, James, M.A., F.R.G.S. Dulwich College, Dulwich, S.E.  
 1912. §Robinson, James. Care of W. Buckley, Esq., Tynemouth-road, North Shields.  
 1888. †Robinson, John, M.Inst.C.E. 8 Vicarage-terrace, Kendal.  
 1908. \*Robinson, John Gorges, B.A. Cragdale, Settle, Yorkshire.  
 1910. †Robinson, John Hargreaves. Cable Ship 'Norseman,' Western Telegraph Co., Caixa no Correu No. 117, Pernambuco, Brazil.  
 1899. \*Robinson, Mark, M.Inst.C.E. Parliament-chambers, Westminster, S.W.  
 1914. †Robinson, Professor R. The University, Liverpool.  
 1904. †Robinson, Theodore R. 25 Campden Hill-gardens, W.  
 1909. †Robinson, Captain W. 264 Roslyn-road, Winnipeg, Canada.  
 1909. †Robinson, Mrs. W. 264 Roslyn-road, Winnipeg, Canada.

Year of  
Election.

1904. †*Robinson, W. H.* *Kendrick House, Victoria-road, Penarth.*  
 1916. §*Robson, C. E.* *Pryorsdale, Clayton-road, Newcastle-on-Tyne.*  
 1912. †*Robson, W. G.* 50 *Farrington-street, Dundee.*  
 1915. §*Roby, Frank Henry.* *New Croft, Alderley Edge.*  
 1885. \**Rodger, Edward.* 1 *Clairmont-gardens, Glasgow.*  
 1905. †*Roebuck, William Denison, F.L.S.* 259 *Hyde Park-road, Leeds.*  
 1908. †*Rogers, A. G. L.* *Board of Agriculture and Fisheries, 8 Whitehall-place, S.W.*  
 1913. †*Rogers, F., D.Eng., B.A.* *Rowardennan, Chelsea-road, Sheffield.*  
 1913. †*Rogers, Sir Hallewell.* *Greville Lodge, Sir Harry's-road, Edgbaston, Birmingham.*  
 1890. \**Rogers, L. J., M.A.,* *Professor of Mathematics in the University of Leeds.* 6 *Hollin-lane, Leeds.*  
 1906. †*Rogers, Reginald A. P.* *Trinity College, Dublin.*  
 1909. †*Rogers, Hon. Robert.* *Roslyn-road, Winnipeg, Canada.*  
 1884. \**Rogers, Walter.* *Care of Capital and Counties Bank, Falmouth.*  
 1876. †*ROLLIT, Sir A. K., LL.D., D.C.L., Litt.D.* *St. Anne's Hall, near Chertsey-on-Thames, Surrey.*  
 1915. †*Roper, R. E., M.A.* *Bedale School, Petersfield.*  
 1905. †*Rose, Miss G. Mabel.* *Ashley Lodge, Oxford.*  
 1883. \**Rose, J. Holland, Litt.D.* *Walsingham, Millington-road, Cambridge.*  
 1894. \**ROSE, Sir T. K., D.Sc.,* *Chemist and Assayer to the Royal Mint.* 6 *Royal Mint, E.*  
 1905. \**Rosedale, Rev. H. G., D.D., F.S.A.* 7 *Gloucester-street, S.W.*  
 1905. \**Rosedale, Rev. W. E., D.D.* *St. Mary Bolton's Vicarage, South Kensington, S.W.*  
 1900. †*ROSENHAIN, WALTER, B.A., F.R.S.* *Warrawee, Coombe-lane, Kingston Hill, Surrey.*  
 1914. †*Rosenhain, Mrs.* *Warrawee, Coombe-lane, Kingston Hill, Surrey.*  
 1914. †*Rosenhain, Miss.* *Warrawee, Coombe-lane, Kingston Hill, Surrey.*  
 1914. †*Ross, Alexander David, M.A., D.Sc., F.R.A.S., F.R.S.E.,* *Professor of Mathematics and Physics in the University of Western Australia, Perth, Western Australia.*  
 1909. †*Ross, D. A.* 116 *Wellington-crescent, Winnipeg, Canada.*  
 1859. \**Ross, Rev. James Coulman.* *Wadworth Hall, Doncaster.*  
 1912. †*Ross, Miss Joan M.* *Hazelwood, Warlingham, Surrey.*  
 1908. †*Ross, Sir John, of Bladensburg, K.C.B.* *Rostrevor House, Rostrevor, Co. Down.*  
 1902. †*Ross, John Callender.* 46 *Holland-street, Campden-hill, W.*  
 1915. †*Ross, Roderick.* *Edinburgh.*  
 1901. †*Ross, Colonel Sir RONALD, K.C.B., F.R.S.* 36 *Harley House, Regent's Park, N.W.*  
 1891. \**Roth, H. Ling.* *Briarfield, Stump Cross, Halifax, Yorkshire.*  
 1911. \**Rothschild, Right Hon. Lord, D.Sc., Ph.D., F.R.S.* *Tring Park, Tring.*  
 1901. \**Rottenburg, Paul, LL.D.* *Care of Messrs. Leister, Bock, & Co., Glasgow.*  
 1899. \**Round, J. C., M.R.C.S.* 19 *Crescent-road, Sydenham Hill, S.E.*  
 1884. \**Rouse, M. L., B.A.* 2 *Exbury-road, Catford, S.E.*  
 1905. †*Rousselet, Charles F.* *Fir Island, Bittacy Hill, Mill Hill, N.W.*  
 1901. †*Rowallan, the Right Hon. Lord.* *Thornliebank House, Glasgow.*  
 1903. \**Rowe, Arthur W., M.B., F.G.S.* *Shottodane, Margate.*  
 1916. \**Rowell, Herbert B.* *The Manor House, Jesmond, Newcastle-on-Tyne.*  
 1890. †*Rowley, Walter, M.Inst.C.E., F.S.A.* *Alderhill, Meanwood, Leeds.*

Year of  
Election.

1910. †Rowse, Arthur A., B.A., B.Sc. 190 Musters-road, West Bridgford, Nottinghamshire.
1901. \*Rudorf, C. C. G., Ph.D., B.Sc. 52 Cranley-gardens, Muswell Hill, N.
1905. \*Ruffer, Sir Marc Armand, C.M.G., M.A., M.D., B.Sc. Quarantine International Board, Alexandria.
1905. †Ruffer, Lady. Alexandria.
1904. †Ruhemann, Dr. S., F.R.S. The Elms, Adams-road, Cambridge.
1909. †Rumball, Rev. M. C., B.A. Morden, Manitoba, Canada.
1896. \*Rundell, T. W., F.R.Met.Soc. Terras Hill, Lostwithiel.
1911. †Rundle, Henry, F.R.C.S. 13 Clarence-parade, Southsea.
1912. \*Rusk, Robert R., M.A., Ph.D. 4 Barns-crescent, Ayr.
1904. †RUSSELL, E. J., D.Sc. (Pres. M, 1916; Council, 1916- )  
Rothamsted Experimental Station, Harpenden, Herts.
1883. \*Russell, J. W. 28 Staverton-road, Oxford.
1852. \*Russell, Norman Scott. Arts Club, Dover-street, W.
1908. †Russell, Robert. *Arduagremia, Haddon-road, Dublin.*
1908. †RUSSELL, Right Hon. T. W., M.P. Olney, Terenure, Co. Dublin.
1886. †Rust, Arthur. Eversleigh, Leicester.
1909. \*Rutherford, Hon. Alexander Cameron. Strathcona, Alberta, Canada.
1907. §RUTHERFORD, Sir ERNEST, M.A., D.Sc., F.R.S. (Pres. A, 1909; Council, 1914- ), Professor of Physics in the University of Manchester.
1914. †Rutherford, Lady. 17 Wilmslow-road, Withington, Manchester.
1914. †Rutherford, Miss Eileen. 17 Wilmslow-road, Withington, Manchester.
1909. †Ruttan, Colonel H. N. Armstrong's Point, Winnipeg, Canada.
1908. †Ryan, Hugh, D.Sc. Omdurman, Orwell Park, Rathgar, Dublin.
1905. †Ryan, Pierce. Rosebank House, Rosebank, Cape Town.
1909. †Ryan, Thomas. Assiniboine-avenue, Winnipeg, Canada.
1906. \*RYMER, Sir JOSEPH SYKES. The Mount, York.
1903. †SADLER, M. E., C.B., LL.D. (Pres. L, 1906), Vice-Chancellor of the University of Leeds. 41 Headingley-lane, Leeds.
1883. †Sadler, Robert. 7 Lulworth-road, Birkdale, Southport.
1871. †Sadler, Samuel Champernowne. Church House, Westminster, S.W.
1903. †Sagar, J. The Poplars, Savile Park, Halifax.
1914. †St. John, J. R. Botanic Gardens, Melbourne.
1915. §Sainter, E. H. Care of Messrs. Steel, Peck, & Tozer, Sheffield.
1873. \*Salomons, Sir David, Bart., F.G.S. Broomhill, Tunbridge Wells.
1904. †SALTER, A. E., D.Sc., F.G.S. 5 Clifton-place, Brighton.
1911. §Sampson, Professor R. A., M.A., F.R.S., Astronomer Royal for Scotland. Royal Observatory, Edinburgh.
1901. †Samuel, John S., J.P., F.R.S.E. City Chambers, Glasgow.
1907. \*Sand, Dr. Henry J. S. The Sir John Cass Technical Institute, Jewry-street, Aldgate, E.C.
1915. \*Sandon, Harold. 51 Dartmouth Park-hill, Kentish Town, N.W.
1896. §Saner, John Arthur, M.Inst.C.E. Toolerstone, Sandiway, Cheshire.
1896. †Saner, Mrs. Toolerstone, Sandiway, Cheshire.
1903. †Sankey, Captain H. R., C.B., R.E., M.Inst.C.E. Palace-chambers, 9 Bridge-street, S.W.
1886. †Sankey, Percy E. 44 Russell-square, W.C.
1896. \*SARGANT, Miss ETHEL, F.L.S. (Pres. K, 1913.) The Old Rectory, Girton, Cambridgeshire.
1907. †Sargent, H. C. Ambergate, near Derby.

Year of  
Election.

1914. †Sargent, O. H. York, Western Australia.  
 1913. †Saundby, Robert, M.D. Great Charles-street, Birmingham.  
 1903. \*SAUNDERS, Miss E. R., F.L.S. (Council, 1914- ) Newnham College, Cambridge.  
 1887. §SAYCE, Rev. A. H., M.A., D.D. (Pres. H, 1887), Professor of Assyriology in the University of Oxford. Queen's College, Oxford.  
 1906. †Sayer, Dr. Ettie. 35 Upper Brook-street, W.  
 1883. \*Scarborough, George. 1 Westfield-terrace, Chapel Allerton, Leeds.  
 1903. †SCARISBRICK, Sir CHARLES, J.P. Scarisbrick Lodge, Southport.  
 1879. \*SCHÄFER, Sir E. A., LL.D., D.Sc., M.D., F.R.S. (PRESIDENT, 1912; GENERAL SECRETARY, 1895-1900; Pres. I, 1894; Council, 1887-93), Professor of Physiology in the University of Edinburgh. Marly Knowe, North Berwick.  
 1914. †Schäfer, Lady. Marly Knowe, North Berwick.  
 1914. †Scharff, J. W. Knockranny, Bray, Co. Wicklow.  
 1914. †Scharff, Mrs. Knockranny, Bray, Co. Wicklow.  
 1888. \*SCHARFF, ROBERT F., Ph.D., B.Sc., Keeper of the Natural History Department, National Museum, Dublin. Knockranny, Bray, Co. Wicklow.  
 1880. \*Schemmann, Louis Carl. Neueberg 12, Hamburg.  
 1905. †SCHÖNLAND, S., Ph.D. Albany Museum, Grahamstown, Cape Colony.  
 1873. \*SCHUSTER, ARTHUR, Ph.D., Sec. R.S., F.R.A.S. (PRESIDENT, 1915; Pres. A, 1892; Council, 1887-93.) Yeldall, Twyford, Berks.  
 1883. \*SCLATER, W. LUTLEY, M.A., F.Z.S. Odiham Priory, Winchfield.  
 1905. †Sclater, Mrs. W. L. Odiham Priory, Winchfield.  
 1913. §Scoble, Walter A., B.Sc., A.M.Inst.C.E. City and Guilds Technical College, Leonard-street, E.C.  
 1881. \*SCOTT, ALEXANDER, M.A., D.Sc., F.R.S., F.C.S. 34 Upper Hamilton-terrace, N.W.  
 1916. §Scott, Alexander, M.A., D.Sc. The University, Glasgow.  
 1878. \*Scott, Arthur William, M.A., Professor of Mathematics and Natural Science in St. David's College, Lampeter.  
 1889. \*SCOTT, D. H., M.A., Ph.D., F.R.S., Pres.L.S. (GENERAL SECRETARY, 1900-03; Pres. K, 1896.) East Oakley House, Oakley, Hants; and Athenæum Club, Pall Mall, S.W.  
 1915. †Scott, Rev. Canon J. J. 65 Ardwick-green, Manchester.  
 1902. †SCOTT, WILLIAM R., M.A., Litt.D., F.B.A. (Pres. F, 1915; Council, 1916- ), Professor of Political Economy in the University of Glasgow. 8 University-gardens, Glasgow.  
 1895. †Scott-Elliott, Professor G. F., M.A., B.Sc., F.L.S. Newton, Dumfries.  
 1883. †Scrivener, Mrs. Haglis House, Wendover.  
 1895. †Scull, Miss E. M. L. St. Edmund's, 10 Worsley-road, Hampstead, N.W.  
 1890. \*Searle, G. F. C., Sc.D., F.R.S. Wyncote, Hills-road, Cambridge.  
 1906. \*See, T. J. J., A.M., Ph.D., F.R.A.S., Professor of Mathematics, U.S. Navy. Naval Observatory, Mare Island, California.  
 1914. †Selby, H. B. 8 O'Connell-street, Sydney, N.S.W.  
 1907. §SELIGMAN, Dr. C. G. (Pres. H, 1915), Professor of Ethnology in the University of London. The Mound, Long Crendon, Thame, Oxon.  
 1911. \*Seligman, Mrs. C. G. The Mound, Long Crendon, Thame, Oxon.  
 1913. §Seligmann, Miss Emma A. 61 Kirklee-road, Kelvinside, Glasgow.

Year of  
Election.

1009. †Sellers, H. Leo. 225 Fifth-avenue, New York, U.S.A.  
 1888. \*SENIER, ALFRED, M.D., Ph.D., D.Sc., F.C.S. (Pres. B, 1912),  
 Professor of Chemistry in University College, Galway.  
 28 Herbert-park, Donnybrook, Co. Dublin.  
 1910. †Seton, R. S., B.Sc. The University, Leeds.  
 1895. \*Seton-Karr, H. W. 8 St. Paul's-mansions, Hammersmith, W.  
 1892. \*SEWARD, A. C., M.A., D.Sc., F.R.S., F.G.S. (Pres. K, 1903 ; Council,  
 1901-07; Local Sec. 1904), Professor of Botany in the Univer-  
 sity of Cambridge. The Master's Lodge, Downing College,  
 Cambridge.  
 1913. †Seward, Mrs. The Master's Lodge, Downing College, Cambridge.  
 1914. †Seward, Miss Phyllis. The Master's Lodge, Downing College,  
 Cambridge.  
 1899. †Seymour, Henry J., B.A., F.G.S., Professor of Geology in the  
 National University of Ireland. Earlsfort-terrace, Dublin.  
 1891. †Shackell, E. W. 191 Newport-road, Cardiff.  
 1905. \*Shackleford, W. C. Barnt Green, Worcestershire.  
 1904. †Shackleton, Lieutenant Sir Ernest H., M.V.O., F.R.G.S. 9 Regent-  
 street, S.W.  
 1902. †SHAFTESBURY, The Right Hon. the Earl of, K.P., K.C.V.O.  
 Belfast Castle, Belfast.  
 1913. †Shakespeare, G. A., D.Sc., M.A. 21 Woodland-road, Northfield,  
 Worcestershire.  
 1901. \*Shakespeare, Mrs. G. A. 21 Woodland-road, Northfield, Worcester-  
 shire.  
 1906. †Shann, Frederick. 6 St. Leonard's, York.  
 1878. †SHARP, DAVID, M.A., M.B., F.R.S., F.L.S. Lawnside, Brocken-  
 hurst, Hants.  
 1904. †Sharples, George. 181 Great Cheetham-street West, Higher  
 Broughton, Manchester.  
 1914. †Shaw, A. G. Merton-crescent, Albert Park, Victoria, Australia.  
 1910. †Shaw, J. J. Sunnyside, Birmingham-road, West Bromwich.  
 1889. \*Shaw, Mrs. M. S., B.Sc. Brookhayes, Exmouth.  
 1883. \*SHAW, Sir NAPIER, M.A., Sc.D., F.R.S. (Pres. A, 1908 ; Council,  
 1895-1900, 1904-07.) Meteorological Office, Exhibition-road,  
 South Kensington, S.W.  
 1883. †Shaw, Lady. 10 Moreton-gardens, South Kensington, S.W.  
 1915. †Shaw, Dr. P. E. University College, Nottingham.  
 1903. †Shaw-Phillips, T., J.P. The Times Library Club, 380 Oxford-  
 street, W.  
 1912. †Shearer, Dr. C., F.R.S. Clare College, Cambridge.  
 1905. †Shenstone, Miss A. Sutton Hall, Barcombe, Lewes.  
 1905. †Shenstone, Mrs. A. E. G. Sutton Hall, Barcombe, Lewes.  
 1865. †Shenstone, Frederick S. Sutton Hall, Barcombe, Lewes.  
 1900. †SHEPPARD, THOMAS, F.G.S. The Municipal Museum, Hull.  
 1908. †Sheppard, W. F., Sc.D., LL.M. Board of Education, White-  
 hall, S.W.  
 1883. †Sherlock, David. Rahan Lodge, Tullamore, Dublin.  
 1883. †Sherlock, Mrs. David. Rahan Lodge, Tullamore, Dublin.  
 1896. †SHERRINGTON, C. S., M.D., D.Sc., F.R.S. (Pres. I, 1904 ; Council,  
 1907-14), Professor of Physiology in the University of Oxford.  
 9 Chadlington-road, Oxford.  
 1888. \*Shickle, Rev. C. W., M.A., F.S.A. St. John's Hospital, Bath.  
 1908. \*Shickle, Miss Mabel G. M. 9 Cavendish-crescent, Bath.  
 1887. \*SHIPLEY, ARTHUR E., M.A., D.Sc., F.R.S. (Pres. D, 1909 ;  
 Council, 1904-11), Master of Christ's College, Cambridge.  
 1897. †SHORE, Dr. LEWIS E. St. John's College, Cambridge.

Year of  
Election.

1882. †SHORE, T. W., M.D., B.Sc., Lecturer on Comparative Anatomy at St. Bartholomew's Hospital. 6 Kingswood-road, Upper Norwood, S.E.
1901. †Short, Peter M., B.Sc. 1 Deronda-road, Herne Hill, S.E.
1908. †Shorter, Lewis R., B.Sc. 29 Albion-street, W.
1917. †Shorter, Dr. S. A. The University, Leeds.
1904. \*Shrubsall, F. C., M.A., M.D. 4 Heathfield-road, Mill Hill Park, Acton, W.
1910. †Shuttleworth, T. E. 5 Park-avenue, Riverdale-road, Sheffield.
1889. †Sibley, Walter K., M.A., M.D. 6 Cavendish-place, W.
1902. †Siddons, A. W., M.A. Harrow-on-the-Hill, Middlesex.
1883. \*Sidebotham, Edward John. Erlesdene, Bowdon, Cheshire.
1877. \*Sidebotham, Joseph Watson. Merlewood, Bowdon, Cheshire.
1914. \*SIDGWICK, Mrs. HENRY (Præs. L, 1915). 27 Grange-road, Cambridge.
1913. \*SIDGWICK, N. V., M.A., D.Sc. Lincoln College, Oxford.
1873. \*SIEMENS, ALEXANDER, M.Inst.C.E. Palace Place-mansions, Kensington Court, W.
1905. †Siemens, Mrs. A. Palace Place-mansions, Kensington Court, W.
1903. \*Silberrad, Dr. Oswald. Buckhurst Hill, Essex.
1915. \*SIMON, Councillor E. D. (Local Sec., 1915.) 20 Mount-street, Manchester.
1914. §Simpson, Dr. G. C., F.R.S. Meteorological Department, Simla, India.
1913. \*Simpson, J. A., M.A., D.Sc. 62 Academy-street, Elgin.
1863. †Simpson, J. B., F.G.S. Hedgefield House, Blaydon-on-Tyne.
1909. †Simpson, Professor J. C. McGill University, Montreal, Canada.
1908. †Simpson, J. J., M.A., B.Sc. Zoological Department, Marischal College, Aberdeen.
1901. \*Simpson, Professor J. Y., M.A., D.Sc., F.R.S.E. 25 Chester-street, Edinburgh.
1907. †Simpson, Lieut.-Colonel R. J. S., C.M.G. 66 Shooter's Hill-road, Blackheath, S.E.
1909. \*Simpson, Samuel, B.Sc., Director of Agriculture, Kampala, Uganda.
1909. †Simpson, Sutherland, M.D. Cornell University Medical College, Ithaca, New York, U.S.A.
1884. \*Simpson, Professor W. J. R., C.M.G., M.D. 31 York-terrace, Regent's Park, N.W.
1909. †Sinclair, J. D. 77 Spence-street, Winnipeg.
1912. †Sinclair, Sir John R. G., Bart., D.S.O. Barrock House, Wick, N.B.
1907. \*Sircar, Dr. Amrita Lal, L.M.S., F.C.S. 51 Sankaritola, Calcutta.
1905. \*SJÖGREN, Professor H. Natural History Museum, Stockholm, Sweden.
1914. \*Skeats, E. W., D.Sc., F.G.S., Professor of Geology in the University, Melbourne.
1902. †Skeffington, J. B., M.A., LL.D. Waterford.
1906. †Skerry, H. A. St. Paul's-square, York.
1883. †Skillicorne, W. N. 9 Queen's-parade, Cheltenham.
1910. †Skinner, J. C. 76 Ivy Park-road, Sheffield.
1916. §Skinner, Leslie S. Bill Quay Shipyard, Bill Quay-on-Tyne.
1898. †SKINNER, SIDNEY, M.A. (Local Sec. 1904.) South-Western Polytechnic, Manresa-road, Chelsea, S.W.
1905. \*Skyrme, C. G. Baltimore, 6 Grange-road, Upper Norwood, S.E.
1913. §Skyrme, Mrs. C. G. Baltimore, 6 Grange-road, Upper Norwood, S.E.

Year of  
Election.

1913. \*SLADE, R. E., D.Sc. University College, Gower-street, W.C.  
 1915. †Slater, Gilbert. Ruskin College, Oxford.  
 1916. §Small, James. Armstrong College, Newcastle-on-Tyne.  
 1915. \*Smalley, J. Norton Grange, Castleton, Manchester.  
 1915. §Smalley, William. Springfield, Castleton, Manchester.  
 1903. \*Smallman, Raleigh S. Eliot Lodge, Albemarle-road, Beckenham.  
 1902. †Smedley, Miss Ida. 36 Russell-square, W.C.  
 1911. †Smiles, Samuel. The Quarry, Sanderstead-road, Sanderstead, Surrey.  
 1911. §Smith, A. Malins, M.A. St. Audrey's Mill House, Thetford, Norfolk.  
 1914. †Smith, Professor A. Micah. School of Mines, Ballarat, Victoria.  
 1892. †Smith, Alexander, B.Sc., Ph.D., F.R.S.E. Department of Chemistry, Columbia University, New York, U.S.A.  
 1908. †Smith, Alfred. 30 Merrion-square, Dublin.  
 1897. †Smith, Andrew, Principal of the Veterinary College, Toronto, Canada.  
 1901. \*SMITH, Miss ANNIE LOBBAIN. 20 Talgarth-road, West Kensington, W.  
 1914. †Smith, Arthur Elliot. 4 Willow Bank, Fallowfield, Manchester.  
 1889. \*SMITH, Professor C. MICHIE, C.I.E., B.Sc., F.R.S.E., F.R.A.S. Winsford, Kodaikanal, South India.  
 1910. †Smith, Charles. 11 Winter-street, Sheffield.  
 1900. §Smith, E. J. Grange House, Westgate Hill, Bradford.  
 1913. \*Smith, Miss E. M. 40 Owlstone-road, Newnham, Cambridge.  
 1908. †Smith, E. Shrapnell. 7 Rosebery-avenue, E.C.  
 1915. §SMITH, E. W. FRASER. (Local Sec. 1916.) 2 Jesmond-gardens, Newcastle-on-Tyne.  
 1886. \*Smith, Mrs. Emma. Hencotes House, Hexham.  
 1901. §Smith, F. B. Care of A. Croxton Smith, Esq., Burlington House, Wandle-road, Upper Tooting, S.W.  
 1866. \*Smith, F. C. Bank, Nottingham.  
 1911. §Smith, F. E. National Physical Laboratory, Teddington, Middlesex.  
 1912. †Smith, Rev. Frederick. The Parsonage, South Queensferry.  
 1897. †SMITH, G. ELLIOT, M.D., F.R.S. (Pres. H, 1912), Professor of Anatomy in the University of Manchester.  
 1914. †Smith, Mrs. G. Elliot. 4 Willow Bank, Fallowfield, Manchester.  
 1903. \*SMITH, Professor H. B. LEES, M.A., M.P. The University, Bristol.  
 1910. §Smith, H. Bompas, M.A. Victoria University, Manchester.  
 1914. †Smith, H. G. Technological Museum, Sydney, N.S.W.  
 1889. \*SMITH, Sir H. LLEWELLYN, K.C.B., M.A., B.Sc., F.S.S. (Pres. F, 1910.) Board of Trade, S.W.  
 1860. \*Smith, Heywood, M.A., M.D. 30 York-avenue, Hove.  
 1876. \*Smith, J. Guthrie. 5 Kirklee-gardens, Kelvinside, Glasgow.  
 1902. †Smith, J. Lorrain, M.D., F.R.S., Professor of Pathology in the University of Edinburgh.  
 1903. \*Smith, James. Pinewood, Crathes, Aberdeen.  
 1915. §Smith, Joseph. 28 Altom-street, Blackburn.  
 1914. †Smith, Miss L. Winsford, Kodaikanal, South India.  
 1914. †Smith, Latimer Elliot. 4 Willow Bank, Fallowfield, Manchester.  
 1910. §Smith, Samuel. Central Library, Sheffield.  
 1894. §Smith, T. Walrond. Care of Frank Henderson, Esq., Thetford, Charles-street, Berkhamsted.  
 1910. †Smith, W. G., B.Sc., Ph.D. College of Agriculture, Edinburgh.  
 1896. \*Smith, Rev. W. Hodson. 104-122 City-road, E.C.  
 1911. †Smith, W. Parnell. The Grammar School, Portsmouth.  
 1913. †Smith, Walter Campbell. British Museum (Natural History), Cromwell-road, S.W.

Year of  
Election.

1885. \*Smith, Watson. 34 Upper Park-road, Haverstock Hill, N.W.  
 1909. †Smith, William. 218 Sherbrooke-street, Winnipeg, Canada.  
 1883. †SMITHELLS, ARTHUR, B.Sc., F.R.S. (Pres. B, 1907; Local Sec. 1890),  
 Professor of Chemistry in the University of Leeds.  
 1909. †Smylie, Hugh. 13 Donegall-square North, Belfast.  
 1914. †Smyth, John, M.A., Ph.D. Teachers' College, Carlton, Victoria.  
 1903. §Smythe, J. A., Ph.D., D.Sc. 10 Queen's-gardens, Benton, New-  
 castle-on-Tyne.  
 1888. \*SNAPE, H. LLOYD, D.Sc., Ph.D. Balholm, Lathom-road, South-  
 port.  
 1913. \*Snell, Sir John, M.Inst.C.E. 8 Queen Anne's-gate, S.W.  
 1905. †SODDY, F., M.A., F.R.S., Professor of Chemistry in the University  
 of Aberdeen.  
 1905. †Sollas, Miss I. B. J., B.Sc. Newnham College, Cambridge.  
 1879. \*SOLLAS, W. J., M.A., Sc.D., F.R.S., F.R.S.E., F.G.S. (Pres. C,  
 1900; Council, 1900-03), Professor of Geology in the Univer-  
 sity of Oxford. 48 Woodstock-road, Oxford.  
 1883. †Sollas, Mrs. 48 Woodstock-road, Oxford.  
 1915. †Somers, Edward. 4 Leaf-square, Pendleton.  
 1900. \*SOMERVILLE, W., D.Sc., F.L.S., Sibthorpiian Professor of Rural  
 Economy in the University of Oxford. 121 Banbury-road,  
 Oxford.  
 1910. \*Sommerville, Duncan M. Y. *The University, St. Andrews, N.B.*  
 1916. §Soulby, Rev. C. T. H. Grange Rectory, Jarrow-on-Tyne.  
 1903. †Soulby, R. M. Sea Holm, Westbourne-road, Birkdale, Lanca-  
 shire.  
 1903. †Southall, Henry T. The Graig, Ross, Herefordshire.  
 1915. §Sowerbutts, Harry. Manchester Geographical Society, 16 St.  
 Mary's Parsonage, Manchester.  
 1883. †Spanton, William Dunnett, F.R.C.S. Chatterley House, Hanley,  
 Staffordshire.  
 1913. §Sparke, Thomas Sparrow. 33 Birkby-crescent, Huddersfield.  
 1909. †Sparling, Rev. J. W., D.D. 159 Kennedy-street, Winnipeg, Canada.  
 1893. \*Speak, John. Kirton Grange, Kirton, near Boston.  
 1910. †Spearman, C. Birnam, Guernsey.  
 1912. †Speers, Adam, B.Sc., J.P. Hollywood, Belfast.  
 1914. †SPENCER, Professor Sir W. BALDWIN, K.C.M.G., M.A., D.Sc.,  
 F.R.S. The University, Melbourne.  
 1910. †Spicer, Rev. E. C. *The Rectory, Waterstock, Oxford.*  
 1894. †Spiers, A. H. Gresham's School, Holt, Norfolk.  
 1864. \*SPILLER, JOHN, F.C.S. 2 St. Mary's-road, Canonbury, N.  
 1909. †Sprague, D. E. 76 Edmonton-street, Winnipeg, Canada.  
 1854. \*SPRAGUE, THOMAS BOND, M.A., LL.D., F.R.S.E. West Holme,  
 Woldingham, Surrey.  
 1915. †Squier, George Owen. 43 Park-lane, W.  
 1888. \*Stacy, J. Sargeant. 152 Shoreditch, E.  
 1903. †Stallworthy, Rev. George B. *The Manse, Hindhead, Haslemere,  
 Surrey.*  
 1883. \*Stanford, Edward, F.R.G.S. 12-14 Long-acre, W.C.  
 1914. \*Stanley, Hon. Sir Arthur, K.C.M.G. State Government House,  
 Melbourne.  
 1894. \*STANSFIELD, ALFRED, D.Sc. McGill University, Montreal,  
 Canada.  
 1909. †Stansfield, Edgar. Mines Branch, Department of Mines, Ottawa,  
 Canada.  
 1900. \*STANSFIELD, Professor H., D.Sc. Hartley University College,  
 Southampton.



Year of  
Election.

1913. §Stanton, T. E., D.Sc., F.R.S. National Physical Laboratory, Teddington, Middlesex.
1911. †STAPF, Dr. OTTO, F.R.S. Royal Gardens, Kew.
1915. §Stapledon, R. G. The Fangan, Llanbadarn, Aberystwyth.
1899. †STARLING, E. H., M.D., F.R.S. (Pres. I, 1909; Council, 1914- ), Professor of Physiology in University College, London, W.C.
1898. †Stather, J. W., F.G.S. Brookside, Newland Park, Hull.
1907. §Staynes, Frank. 36-38 Silver-street, Leicester.
1900. \*STEAD, J. E., D.Sc., F.R.S. (Pres. B, 1910.) 11 Queen's-terrace, Middlesbrough.
1881. †Stead, W. H. Beech-road, Reigate.
1892. \*STEBBING, Rev. THOMAS R. R., M.A., F.R.S. Ephraim Lodge, The Common, Tunbridge Wells.
1896. \*STEBBING, W. P. D., F.G.S. 78A Lexham-gardens, W.
1914. †STEELE, Professor B. D. The University, Brisbane, Australia.
1911. †Steele, L. J., M.I.E.E. H.M. Dockyard, Portsmouth.
1908. †Steele, Lawrence Edward, M.A., M.R.I.A. 18 Crosthwaite-park East, Kingstown, Co. Dublin.
1912. §STEGGALL, J. E. A., M.A., Professor of Mathematics in University College, Dundee. Woodend, Perth-road, Dundee.
1911. †Stein, Sir Marc Aurel, K.C.I.E., D.Sc., D.Litt. Merton College, Oxford.
1909. †Steinkopj, Max. 667 Main-street, Winnipeg, Canada.
1884. \*Stephens, W. Hudson. Low-Ville, Lewis County, New York, U.S.A.
1915. §Stephens, Sir William. 2 Cathedral-street, Manchester.
1902. †Stephenson, G. Grianan, Glasnevin, Dublin.
1910. \*STEPHENSON, H. K. Banner Cross Hall, Sheffield.
1911. †Stern, Moritz. 241 Bristol-road, Birmingham.
1909. †Stethern, G. A. Fort Frances, Ontario, Canada.
1908. \*Steven, Alfred Ingram, M.A., B.Sc. 16 Great Clyde-street, Glasgow.
1906. †Stevens, Miss C. O. The Plain, Foxcombe Hill, Oxford.
1900. †STEVENS, FREDERICK. (Local Sec. 1900.) Town Clerk's Office, Bradford.
1880. \*Stevens, J. Edward, LL.B. Le Mayals, Blackpill, R.S.O.
1915. †Stevens, Marshall. Trafford Hall, Manchester.
1916. §Stevenson, Miss Elizabeth Frances. 24 Brandling-park, New-castle-on-Tyne
1905. †Stewart, A. F. 343 Walmer-road, Toronto, Canada.
1916. §Stewart, A. W., D.Sc. 3 Annfield-road, Partick Hill, Glasgow.
1909. †Stewart, David A., M.D. 407 Pritchard-avenue, Winnipeg, Canada.
1875. \*Stewart, James, B.A., F.R.C.P.Ed. Junior Constitutional Club, Piccadilly, W.
1901. \*Stewart, John Joseph, M.A., B.Sc. 2 Stow Park-crescent, Newport, Monmouthshire.
1901. \*Stewart, Thomas, M.Inst.C.E. St. George's-chambers, Cape Town.
1915. †Stewart, Walter. Ventnor Street Works, Bradford.
1911. †Stibbs, H. A. Portsea Island Gas Company, Commercial-road, Portsmouth.
1913. \*STILES, WALTER. The University, Leeds.
1914. †Stillwell, J. L., M.Sc. University of Adelaide, South Australia.
1914. †Stirling, Miss A. M. Care of Messrs. Elder & Co., 7 St. Helen's-place, Bishopsgate, E.C.

Year of  
Election.

1914. †STIRLING, F. C., C.M.G., M.A., M.D., Sc.D., F.R.S., Professor of Physiology in the University of Adelaide, South Australia.
1876. †STIRLING, WILLIAM, M.D., D.Sc., F.R.S.E., Professor of Physiology in the Victoria University, Manchester.
1904. †Stobbs, J. T. Dunelm, Basford Park, Stoke-on-Trent.
1906. \*Stobo, Mrs. Annie. Somerset House, Garelochhead, Dumbartonshire, N.B.
1901. \*Stobo, Thomas. Somerset House, Garelochhead, Dumbartonshire, N.B.
1883. \*STOCKER, W. N., M.A. Brasenose College, Oxford.
1898. \*Stokes, Professor George J., M.A. 5 Fernhurst-villas, College-road, Cork.
1899. \*Stone, Rev. F. J. Radley College, Abingdon.
1905. †Stoneman, Miss Bertha, D.Sc. Huguenot College, Wellington, Cape Province.
1895. \*Stoney, Miss Edith A. 20 Reynolds-close, Hampstead Way, N.W.
1908. \*Stoney, Miss Florence A., M.D. 4 Nottingham-place, W.
1878. \*STONEY, G. GERALD, F.R.S. (Pres. G, 1916.) Oakley, Heaton-road, Newcastle-upon-Tyne.
1883. †Stopes, Mrs. 4 Kemplay-road, Hampstead, N.W.
1903. \*STOPES, MARIE C., D.Sc., Ph.D., F.L.S. Craigvara, Belmont-road, Leatherhead.
1915. †Stopford, John S. B. Woodbank, Higher Fence-road, Macclesfield.
1910. §Storey, Gilbert. Department of Agriculture, Cairo.
1887. \*Storey, H. L. Bailrigg, Lancaster.
1888. \*Stothert, Percy K. Woolley Grange, Bradford-on-Avon, Wilts.
1905. \*Stott, Clement H., F.G.S. P.O. Box 7, Pietermaritzburg, Natal.
1881. †STRAHAN, AUBREY, M.A., Sc.D., F.R.S., F.G.S. (Pres. C, 1904; Council, 1916- ), Director of the Geological Survey of Great Britain. Geological Museum, Jermyn-street, S.W.
1905. †Strange, Harold F. P.O. Box 2527, Johannesburg.
1908. \*Stratton, F. J. M., M.A. Gonville and Caius College, Cambridge.
1914. †Street, Mr. Justice. Judges' Chambers, Supreme Court, Sydney, N.S.W.
1906. \*Stromeyer, C. E. 9 Mount-street, Albert-square, Manchester.
1883. §Strong, Henry J., M.D. Colonnade House, The Steyne, Worthing.
1898. \*Strong, W. M., M.D. 3 Champion-park, Denmark Hill, S.E.
1887. \*Stroud, H., M.A., D.Sc., Professor of Physics in the Armstrong College, Newcastle-upon-Tyne.
1887. \*STROUD, WILLIAM, D.Sc. Care of Messrs. Barr & Stroud, Anniesland, Glasgow.
1876. \*Stuart, Charles Maddock, M.A. St. Dunstan's College, Catford, S.E.
1885. †Stump, Edward C. Malmesbury, Polefield, Blackley, Manchester.
1909. †Stupart, Sir Frederick. Meteorological Service, Toronto, Canada.
1879. \*Styring, Robert. Brinkcliffe Tower, Sheffield.
1891. \*Sudborough, Professor J. J., Ph.D., D.Sc., F.I.C. Indian Institute of Science, Bangalore, India.
1902. §Sully, H. T. Scottish Widows-buildings, Bristol.
1898. §Sully, T. N. Avalon House, Queen's-road, Weston-super-Mare.
1911. †Summers, A. H., M.A. 16 St. Andrew's-road, Southsea.
1887. \*SUMPNER, W. E., D.Sc. Technical School, Suffolk-street, Birmingham.
1908. †Sutherland, Alexander. School House, Gersa, Watten, Caithness.
1913. §Sutton, A. W. Winkfield Lodge, Wimbledon Common, S.W.
1914. †Sutton, Harvey, M.D., B.Sc. Trinity College, Parkville, Victoria.
1911. †Sutton, Leonard, F.L.S. Hillside, Reading.
1911. †Sutton, W. L., F.I.C. Hillcroft, Eaton, Norwich.

Year of  
Election.

1903. †*Swallow, Rev. R. D., M.A. Chigwell School, Essex.*  
 1905. †*Swan, Miss Mary E. Overhill, Warlingham, Surrey.*  
 1911. \**SWANN, Dr. W. F. G. Department of Terrestrial Magnetism  
Carnegie Institution of Washington, Washington, D.C.  
U.S.A.*  
 1897. †*Swanston, William, F.G.S. Mount Collyer Factory, Belfast.*  
 1914. §*Sweet, George, F.G.S. The Close, Brunswick, Victoria.*  
 1914. †*Sweet, Miss Georgina, D.Sc. The Close, Brunswick, Victoria.*  
 1913. †*Swift, Richard H. 4839 St. Lawrence-avenue, Chicago.*  
 1914. †*Swinburne, Hon. George. 139 Collins-street, Melbourne.*  
 1887. §*SWINBURNE, JAMES, F.R.S., M.Inst.C.E. 82 Victoria-street,  
S.W.*  
 1913. †*Swinnerton, H. H. 441 Mansfield-road, Nottingham.*  
 1902. \**Sykes, Miss Ella C. Elcombs, Lyndhurst, Hampshire.*  
 1887. \**Sykes, George H., M.A., M.Inst.C.E., F.S.A. Glencoe, 64 Elm-  
bourne-road, Tooting Common, S.W.*  
 1913. §*Sykes, Godfrey G. Desert Laboratory, Tucson, Arizona, U.S.A.*  
 1896. \**Sykes, Mark L., F.R.M.S. 75 Cardigan-road, Leeds.*  
 1902. \**Sykes, Major P. Molesworth, C.M.G. Elcombs, Lyndhurst,  
Hampshire.*  
 1906. †*Sykes, T. P., M.A. 4 Gathorne-street, Great Horton, Bradford.*  
 1914. †*Syme, Mrs. D. York. Balwyn, Victoria.*  
 1903. §*Symington, Howard W. Brooklands, Market Harborough.*  
 1885. †*SYMINGTON, JOHNSON, M.D., F.R.S., F.R.S.E. (Pres. H, 1903),  
Professor of Anatomy in Queen's University, Belfast.*  
 1914. †*Symington, Miss N. Queen's University, Belfast.*  
 1908. †*Synnot, Nicholas J. Furness, Naas, Co. Kildare.*  
 1910. \**Tait, John, M.D., D.Sc. 44 Viewforth-terrace, Edinburgh.*  
 1916. §*Talbot, John. 4 Brandling-park, Newcastle-on-Tyne.*  
 1912. †*Talbot, P. Amaury. Abbots Morton, Inkberrow, Worcestershire.*  
 1904. †*Tallack, H. T. Clovelly, Birdhurst-road, South Croydon.*  
 1913. §*Tangye, William. Westmere, Edgbaston Park-road, Birmingham.*  
 1903. \**Tanner, Miss Ellen G. 8 Cavendish-place, Bath.*  
 1892. \**TANSLEY, ARTHUR G., M.A., F.L.S. Grantchester, near  
Cambridge.*  
 1908. †*TARLETON, FRANCIS A., LL.D. 24 Upper Leeson-street, Dublin.*  
 1861. \**Tarratt, Henry W. 25 Glyn-mansions, Addison Bridge, Ken  
sington, W.*  
 1902. †*Tate, Miss. Rantalard, Whitehouse, Belfast.*  
 1913. §*Tattersall, W. M., D.Sc. The Museum, The University, Manchester.*  
 1914. †*Taylor, C. Z. 216 Smith-street, Collingwood, Victoria.*  
 1908. †*Taylor, Rev. Campbell, M.A. United Free Church Manse,  
Wigtown, Scotland.*  
 1887. †*Taylor, G. H. Holly House, 235 Eccles New-road, Salford.*  
 1906. †*Taylor, H. Dennis. Stancliffe, Mount-villas, York.*  
 1884. \**TAYLOR, H. M., M.A., F.R.S. Trinity College, Cambridge.*  
 1882. \**Taylor, Herbert Owen, M.D. Oxford-street, Nottingham.*  
 1914. †*Taylor, J. M., M.A. Public Service Board, 4 O'Connell-street,  
Sydney, N.S.W.*  
 1913. †*Taylor, J. S. The Corinthians, Warwick-road, Acock's Green.*  
 1915. §*Taylor, J. W., D.Sc. Skipton-street, Morecambe.*  
 1860. \**Taylor, John, M.Inst.C.E. 6 Queen Street-place, E.C.*  
 1906. §*Taylor, Miss M. R. Newstead, Blundellsands.*  
 1884. \**Taylor, Miss S. Oak House, Shaw, near Oldham.*

Year of  
Election.

1894. \*Taylor, W. W., M.A. 66 St. John's-road, Oxford.  
 1901. \*Teacher, John H., M.B. 32 Kingsborough-gardens, Glasgow.  
 1858. †TEALE, THOMAS PRIDGIN, M.A., F.R.S. 38 Cookridge-street, Leeds.  
 1885. †TEALL, Sir J. J. H., M.A., D.Sc., F.R.S., F.G.S. (Pres. C, 1893 ; Council, 1894-1900, 1909-16.) Athenæum Club, S.W.  
 1906. \*Teape, Rev. W. M., M.A. South Hylton Vicarage, Sunderland.  
 1910. †Tebb, W. Scott, M.A., M.D. 15 Finsbury-circus, E.C.  
 1879. †Temple, Lieutenant G. T., R.N., F.R.G.S. Solheim, Cumberland Park, Acton, W.  
 1913. †TEMPLE, Sir R. C., Bart., C.B., C.I.E. (Pres. H, 1913.) The Nash, Worcester.  
 1916. \*TEMPLE, Rev. W., M.A. (Pres. L., 1916.) St. James's Rectory, Piccadilly, W.  
 1892. \*Tesla, Nikola. 45 West 27th-street, New York, U.S.A.  
 1883. †Tetley, C. F. The Brewery, Leeds.  
 1883. †Tetley, Mrs. C. F. The Brewery, Leeds.  
 1882. \*THANE, GEORGE DANCER, LL.D., Professor of Anatomy in University College, London, W.C.  
 1915. †Thewlis, J. Herbert. Daisy Mount, Victoria Park, Manchester.  
 1871. †THISSELTON-DYER, Sir W. T., K.C.M.G., C.I.E., M.A., B.Sc., Ph.D., LL.D., F.R.S., F.L.S. (Pres. D, 1888 ; Pres. K, 1895 ; Council, 1885-89, 1895-1900.) The Ferns, Witcombe, Gloucester.  
 1906. \*THODAY, D., M.A. The University, Manchester.  
 1906. \*Thoday, Mrs. M. G. 6 Lyme-park, Chinley, Stockport.  
 1870. †Thom, Colonel Robert Wilson, J.P. Brooklands, Lord-street West, Southport.  
 1891. \*Thomas, Miss Clara. Pencerrig, Builth.  
 1903. \*THOMAS, MISS ETHEL N., D.Sc. 3 Downe-mansions, Gondar-gardens, West Hampstead, N.W.  
 1913. †Thomas, H. H., M.A., B.Sc., F.G.S. 28 Jermyn-street, S.W.  
 1910. \*Thomas, H. Hamshaw. Botany School, Cambridge.  
 1899. \*Thomas, Mrs. J. W. Overdale, Shortlands, Kent.  
 1902. \*Thomas, Miss M. Beatrice. Girton College, Cambridge.  
 1883. †Thomas, Thomas H. 45 The Walk, Cardiff.  
 1904. \*Thomas, William, F.R.G.S. Bryn-heulog, Merthyr Tydfil.  
 1891. \*Thompson, Beeby, F.C.S., F.G.S. 67 Victoria-road, Northampton.  
 1888. \*Thompson, Claude M., M.A., D.Sc., Professor of Chemistry in University College, Cardiff. 38 Park-place, Cardiff.  
 1885. †THOMPSON, D'ARCY W., C.B., B.A., F.R.S. (Pres. D, 1911 ; Local Sec. 1912), Professor of Zoology in University College, Dundee.  
 1896. \*Thompson, Edward P. Paulsmoss, Whitchurch, Salop.  
 1907. \*Thompson, Edwin. 25 Sefton-drive, Liverpool.  
 1883. \*Thompson, Francis. Eversley, Haling Park-road, Croydon.  
 1904. \*Thompson, G. R., B.Sc., Principal of and Professor of Mining in the South African School of Mines, Johannesburg.  
 1912. \*Thompson, Rev. H. Percy. Kippington Vicarage, Sevenoaks.  
 1893. \*Thompson, Harry J., M.Inst.C.E. Tregarthen, Garland's-road, Leatherhead.  
 1913. \*Thompson, Mrs. Lilian Gilchrist. Kippington Vicarage, Sevenoaks.  
 1913. †Thompson, Peter. 14 Rotten Park-road, Edgbaston, Birmingham.  
 1876. \*Thompson, Richard. Dringcote, The Mount, York.  
 1913. \*Thompson, Sidney Gilchrist. Kippington Vicarage, Sevenoaks.  
 1883. \*Thompson, T. H. Oldfield Lodge, Gray-road, Bowdon, Cheshire.  
 1896. \*THOMPSON, W. H., M.D., D.Sc. (Local Sec. 1908), King's Professor of Institutes of Medicine (Physiology) in Trinity College, Dublin. 14 Hatch-street, Dublin.

Year of  
Election.

1911. †Thompson, Mrs. W. H. 328 Assiniboine-avenue, Winnipeg.  
 1912. †Thompson, William Bruce. Thornbank, Dundee.  
 1912. §Thoms, Alexander. 7 Playfair-terrace, St. Andrews.  
 1894. †THOMSON, ARTHUR, M.A., M.D., Professor of Human Anatomy in the University of Oxford. Exeter College, Oxford.  
 1913. †Thomson, Arthur W., D.Sc. 23 Craven Hill-gardens, W.  
 1912. §Thomson, D. C. 'Courier' Buildings, Dundee.  
 1909. \*Thomson, E. 22 Monument-avenue, Swampscott, Mass., U.S.A.  
 1906. §Thomson, F. Ross, F.G.S. Hensill, Hawkhurst, Kent.  
 1914. §Thomson, Hedley J., Assoc.M.Inst.C.E. 14 Leonard-place, High-street, Kensington, W.  
 1890. \*THOMSON, Professor J. ARTHUR, M.A., F.R.S.E. Castleton House, Old Aberdeen.  
 1883. †THOMSON, Sir J. J., O.M., M.A., Sc.D., D.Sc., Pres. R.S. (PRESIDENT, 1909; Pres. A, 1896; Council, 1893-95), Professor of Experimental Physics in the University of Cambridge. Trinity College, Cambridge.  
 1889. \*Thomson, James, M.A. 22 Wentworth-place, Newcastle-upon-Tyne.  
 1902. †Thomson, James Stuart. 4 Highfield, Chapel-en-le-Frith, Derbyshire.  
 1891. †Thomson, John. Westover, Mount Ephraim-road, Streatham, S.W.  
 1871. \*THOMSON, JOHN MILLAR, LL.D., F.R.S. (Council, 1895-1901), Professor of Chemistry in King's College, London. 5 Chesham Crescent, W.  
 1874. §THOMSON, WILLIAM, F.R.S.E., F.C.S. Royal Institution, Manchester.  
 1906. †Thornely, Miss A. M. M. Oaklands, Langham-road, Bowdon, Cheshire.  
 1905. \*Thornely, Miss L. R. Nunclose, Grassendale, Liverpool.  
 1898. \*THORNTON, W. M., D.Sc., Professor of Electrical Engineering in the Armstrong College, Newcastle-on-Tyne.  
 1902. †Thornycroft, Sir John I., F.R.S., M.Inst.C.E. Eyot Villa, Chiswick Mall, W.  
 1903. †Thorp, Edward. 87 Southbank-road, Southport.  
 1881. †Thorp, Fielden. Blossom-street, York.  
 1881. \*Thorp, Josiah. 24 Manville-road, New Brighton, Cheshire.  
 1898. †THORPE, JOCELYN FIELD, Ph.D., F.R.S., Professor of Organic Chemistry in the Imperial College of Science and Technology, S.W.  
 1871. †THORPE, Sir T. E., C.B., Ph.D., LL.D., F.R.S., F.R.S.E., F.C.S. (Pres. B, 1890; Council, 1886-92.) Whinfield, Salcombe, Devon.  
 1899. §THRELFALL, RICHARD, M.A., F.R.S. Oakhurst, Church-road, Edgbaston, Birmingham.  
 1896. §THRIFF, WILLIAM EDWARD, M.A. (Local Sec. 1908), Professor of Natural and Experimental Philosophy in the University of Dublin. 80 Grosvenor-square, Rathmines, Dublin.  
 1873. \*TYDDEMAN, R. H., M.A., F.G.S. 298 Woodstock-road, Oxford.  
 1905. †Tietz, Heinrich, B.A., Ph.D. South African College, Cape Town.  
 1874. †TILDEN, Sir WILLIAM A., D.Sc., F.R.S., F.C.S. (Pres. B, 1888; Council, 1898-1904.) The Oaks, Northwood, Middlesex.  
 1913. †Tilley, J. W. Field House, Harborne, Park-road, Birmingham.  
 1899. †Tims, H. W. Marett, M.A., M.D., F.L.S. Bedford College, Regent's Park, N.W.  
 1914. †Tims, Mrs. Marett. Bedford College, Regent's Park, N.W.  
 1916. §Tinker, Frank. The University, Birmingham.

Year of  
Election.

1902. †Tipper, Charles J. R., B.Sc. 21 Greenside, Kendal.
1905. †Tippett, A. M., M.Inst.C.E. Cape Government Railways, Cape Town.
1911. †Tizard, Henry T. Oriel College, Oxford.
1900. \*Tocher, J. F., D.Sc., F.I.C. Crown-mansions, 41½ Union-street, Aberdeen.
1912. §Todd, John A. 3 Mapperley Hall-drive, Nottingham.
1907. †Todd, Professor J. L. MacDonald College, Quebec, Canada.
1889. §Toll, John M. 49 Newsham-drive, Liverpool.
1875. †Torr, Charles Hawley. 35 Burlington-road, Sherwood, Nottingham.
1909. †Tory, H. M. Edmonton, Alberta, Canada.
1912. †Tosh, Elmslie. 11 Reform-street, Dundee.
1901. †Townsend, J. S., M.A., F.R.S., Professor of Physics in the University of Oxford. New College, Oxford.
1876. \*TRAIL, J. W. H., M.A., M.D., F.R.S., F.L.S. (Pres. K, 1910), Regius Professor of Botany in the University of Aberdeen.
1870. †TRAILL, WILLIAM A. Giant's Causeway Electric Tramway, Portrush, Ireland.
1914. \*Trechmann, C. T. Hudworth Tower, Castle Eden, Durham.
1884. †Trechmann, Charles O., Ph.D., F.G.S. Hartlepool.
1908. †Treen, Rev. Henry M., B.Sc. 3 Stafford-road, Weston-super-Mare.
1908. †Tremain, Miss Caroline P., B.A. Alexandra College, Dublin.
1911. §Tremearne, Mrs., LL.A., F.L.S. 105 Blackheath-park, S.E.
1914. †Tremearne, Mrs. Ada J. Mandeville Hall, Clendon-road, Toorak, Victoria.
1887. \*Trench-Gascoigne, Mrs. F. R. Lotherton Hall, Parlington, Aberford, Leeds.
1903. †Trenchard, Hugh. The Firs, Clay Hill, Enfield.
1908. †Tresilian, R. S. Cumnor, Eglinton-road, Dublin.
1916. §Trevelyan, C. P., M.P. Cambo, Morpeth.
1905. †TREVOR-BATTYE, A., M.A., F.L.S., F.R.G.S. Stoner Hill, Petersfield, Hants.
1916. §Tripp, Dr. E. H. 3 Milton-road, Bedford.
1902. †Tristram, Rev. J. F., M.A., B.Sc. 20 Chandos-road, Chorlton-cum-Hardy, Manchester.
1884. \*Trotter, Alexander Pelham. 8 Richmond-terrace, Whitehall, S.W.
1914. †Trouton, Eric. The Rydings, Redington-road, Hampstead, N.W.
1887. \*TROUTON, FREDERICK T., M.A., Sc.D., F.R.S. (Pres. A, 1914; Council, 1911-14.) The Rydings, Redington-road, Hampstead, N.W.
1914. †Trouton, Mrs. The Rydings, Redington-road, Hampstead, N.W.
1898. \*TROW, ALBERT HOWARD, D.Sc., F.L.S., Professor of Botany in University College, Cardiff.
1913. †Tschugaeff, Professor L. The University, Petrograd.
1885. \*Tubby, A. H., M.S., F.R.C.S. 68 Harley-street, W.
1905. §Turmeau, Charles. Claremont, Victoria Park, Wavertree, Liverpool.
1912. †Turnbull, John. City Chambers, Dundee.
1901. §Turnbull, Robert, B.Sc. Department of Agriculture and Technical Instruction, Dublin.
1914. †Turner, Dr. A. J. Wickham-terrace, Brisbane, Australia.
1893. †TURNER, DAWSON, M.D., F.R.S.E. 37 George-square, Edinburgh.
1913. §Turner, G. M. Kenilworth,

Year of  
Election.

1894. \*TURNER, H. H., M.A., D.Sc., F.R.S., F.R.A.S. (GENERAL SECRETARY, 1913- ; Pres. A, 1911), Professor of Astronomy in the University of Oxford. University Observatory, Oxford.
1916. §Turner, Miss J., B.A. 14 Endsleigh-street, W.C.
1905. †Turner, Rev. Thomas. St. Saviour's Vicarage, 50 Fitzroy-street, W.
1886. \*TURNER, THOMAS, M.Sc., A.R.S.M., F.I.C., Professor of Metallurgy in the University of Birmingham. 75 Middleton Hall-road, King's Norton.
1910. \*Turner, W. E. S. The University, Sheffield.
1890. \*Turpin, G. S., M.A., D.Sc. High School, Nottingham.
1907. §TUTTON, A. E. H., M.A., D.Sc., F.R.S. (Council, 1908-12.) Duart, Yelverton, South Devon.
1915. \*Tweedale, Samucl. Sanbridge House, Castleton, Manchester.
1886. \*Twigg, G. H. Rednall, near Birmingham.
1899. †Twisden, John R., M.A. 14 Gray's Inn-square, W.C.
1907. §Twyman, F. 75A Camden-road, N.W.
1911. \*TYNDALL, A. M., M.Sc. The University, Bristol.
1883. †Tyter, Thomas, F.C.S. Stirling Chemical Works, Abbey-lane, Stratford, E.
1912. †Tyrrell, G. W. Geological Department, The University, Glasgow.
1884. \*Underhill, G. E., M.A. Magdalen College, Oxford.
1903. †Underwood, Captain J. C. 60 Scarisbrick New-road, Southport.
1908. §UNWIN, Ernest Ewart, M.Sc. Grove House, Leighton Park School, Reading.
1883. §Unwin, John. Eastcliffe Lodge, Southport.
1876. \*UNWIN, W. C., F.R.S., M.Inst.C.E. (Pres. G, 1892 ; Council, 1892-99.) 7 Palace Gate-mansions, Kensington, W.
1909. †Urquhart, C. 239 Smith-street, Winnipeg, Canada.
1880. †USSHER, W. A. E., F.G.S. 28 Jermyn-street, S.W.
1905. †Uttley, E. A., Electrical Inspector to the Rhodesian Government, Bulawayo.
1887. \*Valentine, Miss Anne. The Elms, Hale, near Altrincham.
1912. †Valentine, C. W. Queen's University, Belfast.
1908. †Valera, Edward de. University College, Blackrock, Dublin.
1865. \*VABLEY, S. ALFRED. Arrow Works, Jackson-road, Holloway, N.
1907. §VABLEY, W. MANSERGH, M.A., D.Sc., Ph.D. Morningside, Eaton-crescent, Swansea.
1903. †Varwell, H. B. Sittaford, West-avenue, Exeter.
1917. §Vassall, Archer, M.A., F.Z.S. Elmfield, Harrow.
1909. \*Vassall, H., M.A. The Priory, Repton, Derby.
1905. †Vaughan, E. L. Eton College, Windsor.
1913. †Vaughton, T. A. Livery-street, Birmingham.
1881. †VELEY, V. H., M.A., D.Sc., F.R.S. 8 Marlborough-place, St. John's Wood, N.W.
1883. \*Verney, Lady. Plas Rhoscolyn, Holyhead.
1904. \*Vernon, H. M., M.A., M.D. 5 Park Town, Oxford.
1896. \*Vernon, Thomas T. Shotwick Park, Chester.
1896. \*Vernon, Sir William, Bart. Shotwick Park, Chester.
1890. \*Villamil, Lieut.-Colonel R. de, R.E. Carlisle Lodge, Rickmansworth.

Year of  
Election.

1906. \*VINCENT, J. H., M.A., D.Sc. L.C.C. Paddington Technical Institute, Saltram-crescent, W.
1899. \*VINCENT, SWALE, M.D., D.Sc. (Local Sec. 1909), Professor of Physiology in the University of Manitoba, Winnipeg, Canada.
1883. \*VINES, SYDNEY HOWARD, M.A., D.Sc., F.R.S., F.L.S. (Pres. K, 1900 ; Council, 1894-97), Professor of Botany in the University of Oxford. Headington Hill, Oxford.
1902. †Vinycomb, T. B. Ardmore, Shooter's Hill, S.E.
1904. §Volterra, Professor Vito. Regia Università, Rome.
1904. §Wace, A. J. B. Pembroke College, Cambridge.
1902. †Waddell, Rev. C. H. The Vicarage, Grey Abbey, Co. Down.
1916. §Waddell, Kerr. Riverslea, Grassendale Park, Liverpool.
1909. †Wadge, Herbert W., M.D. 754 Logan-avenue, Winnipeg, Canada.
1888. †Wadworth, H. A. Breinton Court, near Hereford.
1914. †Wadsworth, Arthur. Commonwealth Parliament, Melbourne.
1890. §WAGER, HAROLD W. T., F.R.S., F.L.S. (Pres. K, 1905.) Hendre, Horsforth-lane, Far Headingley, Leeds.
1900. †Wagstaff, C. J. L., B.A. Haberdashers' School, Cricklewood, N.W.
1902. †Wainwright, Joel. Finchwood, Marple Bridge, Stockport.
1906. †Wakefield, Charles. Heslington House, York.
1905. §Wakefield, Captain E. W. Stricklandgate House, Kendal.
1916. §Wale, Bernard H. Seale Hague College, Newton Abbot, Devon.
1894. †WALFORD, EDWIN A., F.G.S. 21 West Bar, Banbury.
1882. \*Walkden, Samuel, F.R.Met.S. Windypost, Broadstairs, Kent.
1890. †Walker, A. Tannett. The Elms, Weetwood, Leeds.
1893. †Walker, Alfred O., F.L.S. Ulcombe Place, Maidstone, Kent.
1901. \*Walker, Archibald, M.A., F.I.C. Newark Castle, Ayr, N.B.
1904. §Walker, E. R. The Palace Hydro Hotel, Birkdale Park, Southport.
1911. \*WALKER, E. W. AINLEY, M.A. University College, Oxford.
1916. §Walker, F. H. 3 Stannington-grove, Heaton, Newcastle-on-Tyne.
1897. \*WALKER, Sir EDMUND, C.V.O., D.C.L., F.G.S. (Local Sec. 1897.) Canadian Bank of Commerce, Toronto, Canada.
1915. §Walker, Edward J., M.D. 46 Deansgate-arcade, Manchester.
1891. †Walker, Frederick W. Tannett. Carr Manor, Meanwood, Leeds.
1894. \*WALKER, Sir G. T., C.S.I., M.A., D.Sc., F.R.S., F.R.A.S. Meteorological Office, Simla, India.
1897. †Walker, George Blake, M.Inst.C.E. Tankersley Grange, near Barnsley.
1913. §Walker, George W., M.A., F.R.S. Heath Cottage, Boar's Hill, near Oxford.
1906. †Walker, J. F. E. Gelson, B.A. 45 Bootham, York.
1894. \*WALKER, JAMES, M.A. 30 Norham-gardens, Oxford.
1910. \*WALKER, JAMES, D.Sc., F.R.S. (Pres. B, 1911), Professor of Chemistry in the University of Edinburgh. 5 Wester Coates-road, Edinburgh.
1906. †Walker, Dr. Jamieson. 37 Charnwood-street, Derby.
1909. †Walker, Lewie D. Lieberose, Monteith-road, Cathcart, Glasgow.
1915. †Walker, Professor Miles. School of Technology, Manchester.
1907. †Walker, Philip F., F.R.G.S. 36 Prince's-gardens, S.W.
1909. §Walker, Mrs. R. 3 Riviera-terrace, Rushbrooke, Queenstown, Co. Cork.
1908. \*Walker, Robert. Ormidale, Combe Down, Bath.



Year of  
Election.

1888. †Walker, Sydney F. 1 Bloomfield-crescent, Bath.  
 1896. §Walker, Colonel William Hall, M.P. Gateacre, Liverpool.  
 1914. †Walkom, A. B. The University, Brisbane, Australia.  
 1910. †Wall, G. P., F.G.S. 32 Collegiate-crescent, Sheffield.  
 1883. †Wall, Henry. 14 Park-road, Southport.  
 1911. †WALL, THOMAS F., D.Sc., Assoc.M.Inst.C.E. The University, Birmingham.  
 1916. §Wallace, Colonel Johnstone. Parkholme, Beech Grove-road, Newcastle-on-Tyne.  
 1905. †Wallace, R. W. 2 Harcourt-buildings, Temple, E.C.  
 1901. †Wallace, William, M.A., M.D. 25 Newton-place, Glasgow.  
 1887. \*WALLER, AUGUSTUS D., M.D., F.R.S. (Pres. I, 1907.) 32 Grove End-road, N.W.  
 1905. §Waller, Mrs. 32 Grove End-road, N.W.  
 1913. \*Waller, J. C., B.A. 32 Grove End-road, N.W.  
 1913. \*Waller, Miss M. D., B.Sc., 32 Grove End-road, N.W.  
 1913. \*Waller, W. W., B.A., 32 Grove End-road, N.W.  
 1915. §Wallis, B. C. 16 Windermere-avenue, Church End, Finchley, N.  
 1895. †WALLIS, E. WHITE, F.S.S. Royal Sanitary Institute and Parkes Museum, 90 Buckingham Palace-road, S.W.  
 1894. \*WALMISLEY, A. T., M.Inst.C.E. 9 Victoria-street, Westminster, S.W.  
 1891. §Walmsley, R. M., D.Sc. Northampton Institute, Clerkenwell, E.C.  
 1903. †Walsh, W. T. H. Kent Education Committee, Caxton House, Westminster, S.W.  
 1895. †WALSINGHAM, The Right Hon. Lord, LL.D., F.R.S. Merton Hall, Thetford.  
 1902. \*Walter, Miss L. Edna. 18 Norman-road, Heaton Moor, Stockport.  
 1904. \*Walters, William, jun. Albert House, Newmarket.  
 1887. †WARD, Sir A. W., M.A., Litt.D., Master of Peterhouse, Cambridge.  
 1911. †Ward, A. W. Town Hall, Portsmouth.  
 1881. §Ward, George, F.C.S. Buckingham-terrace, Headingley, Leeds.  
 1914. †Ward, L. Keith, B.E. Burnside-road, Kensington Park, South Australia.  
 1914. †Ward, Thomas W. Endcliffe Vale House, Sheffield.  
 1905. †Warlow, Dr. G. P. 15 Hamilton-square, Birkenhead.  
 1887. †WARREN, General Sir CHARLES, R.E., K.C.B., G.C.M.G., F.R.S., F.R.G.S. (Pres. E, 1887.) Athenæum Club, S.W.  
 1913. §Warren, William Henry, LL.D., M.Sc., M.Inst.C.E., Challis Professor of Engineering in the University of Sydney, N.S.W.  
 1913. †Warton, Lieut.-Colonel R. G. St. Helier, Jersey.  
 1914. †Waterhouse, G. A., B.Sc. Royal Mint, Sydney, N.S.W.  
 1875. \*WATERHOUSE, Major-General J. Hurstmead, Eltham, Kent.  
 1905. †Watermeyer, F. S., Government Land Surveyor. P.O. Box 973, Pretoria, South Africa.  
 1916. §Waters, Miss Charlotte M. Cotswold, Hurst Green, Oxied, Surrey.  
 1900. †Waterston, David, M.D., F.R.S.E. King's College, Strand, W.C.  
 1909. §Watkinson, Professor W. H. The University, Liverpool.  
 1884. †Watson, A. G., D.C.L. Uplands, Wadhurst, Sussex.  
 1901. \*WATSON, ARNOLD THOMAS, F.L.S. Southwold, Tipton Crescent-road, Sheffield.  
 1886. \*Watson, C. J. Alton Cottage, Botteville-road, Acock's Green, Birmingham.  
 1906. †Watson, D. M. S. University College, London, W.C.  
 1909. †Watson, Ernest Ansley, B.Sc. Alton Cottage, Botteville-road, Acock's Green, Birmingham.  
 1892. †Watson, G., M.Inst.C.E. 5 Ruskin-close, Hampstead Way, N.W.

Year of  
Election.

1885. †Watson, Deputy Surgeon-General G. A. Hendre, Overton Park, Cheltenham.
1915. \*Watson, G. N. Trinity College, Cambridge.
1906. \*Watson, Henry Angus. 3 Museum-street, York.
1913. †Watson, John D., M.Inst.C.E. Tyburn, Birmingham.
1894. \*WATSON, Professor W., D.Sc., F.R.S. 7 Upper Cheyne-row, S.W.
1915. \*Watson, Walter, B.Sc. Taunton School, Somerset.
1879. \*WATSON, WILLIAM HENRY, F.C.S., F.G.S. Braystones' House, Beckermet, Cumberland.
1901. †Watt, Harry Anderson, M.P. Ardenslate House, Hunter's Quay, Argyllshire.
1913. \*Watt, James. 28 Charlotte-square, Edinburgh.
1875. \*WATTS, JOHN, B.A., D.Sc. Merton College, Oxford.
1873. \*WATTS, W. MARSHALL, D.Sc. Shirley, Venner-road, Sydenham, S.E.
1883. \*WATTS, W. W., M.A., M.Sc., F.R.S., F.G.S. (Pres. C, 1903; Council, 1902-09), Professor of Geology in the Imperial College of Science and Technology, London, S.W.
1870. §Watts, William, M.Inst.C.E., F.G.S. Kenmore, Wilmslow, Cheshire.
1905. †Way, W. A., M.A. The College, Graaf Reinet, South Africa.
1907. †Webb, Wilfred Mark, F.L.S. The Hermitage, Hanwell, W.
1910. †Webster, Professor Arthur G. Worcester, Massachusetts, U.S.A.
1910. †Webster, William, M.D. 1252 Portage-avenue, Winnipeg, Canada.
1916. §Weddas, Percy. Oakwood, Cockfield, Co. Durham.
1904. †Wedderburn, Ernest Maclagan, D.Sc., F.R.S.E. 7 Dean Park-crescent, Edinburgh.
1903. †Weekes, R. W., A.M.Inst.C.E. 65 Hayes-road, Bromley, Kent.
1916. §Weighton, R. L., D.Sc., Professor of Engineering in Armstrong College, Newcastle-on-Tyne.
1914. †Weir, G. North Mine, Broken Hill, New South Wales.
1890. \*WEISS, FREDERICK ERNEST, D.Sc., F.L.S. (Pres. K, 1911; Council, 1914- ), Professor of Botany in the Victoria University, Manchester.
1905. †Welby, Miss F. A. Hamilton House, Hall-road, N.W.
1916. §Welch, J. J., M.Sc., Professor of Naval Architecture in Armstrong College, Newcastle-on-Tyne.
1902. †Welch, R. J. 49 Lonsdale-street, Belfast.
1894. †Weld, Miss. 119 Iffley-road, Oxford.
1880. \*Weldon, Mrs. Merton Lea, Oxford.
1908. †Welland, Rev. C. N. Wood Park, Kingstown, Co. Dublin.
1881. §Wellcome, Henry S. Snow Hill-buildings, E.C.
1911. †WELLDON, Right Rev. J. E. C., D.D. (Pres. L, 1911.) The Deanery, Manchester.
1881. †Wells, Rev. Edward, M.A. West Dean Rectory, Salisbury.
1911. \*WELSFORD, Miss E. J. Imperial College of Science and Technology, S.W.
1886. \*Wertheimer, Julius, D.Sc., B.A., F.I.C., Dean of the Faculty of Engineering in the University of Bristol.
1910. §WEST, G. S., M.A., D.Sc., Professor of Botany in the University of Birmingham.
1903. †Westaway, F. W. 1 Pemberley-crescent, Bedford.
1882. \*Westlake, Ernest, F.G.S. Fordingbridge, Salisbury.
1900. †Wethey, E. R., M.A., F.R.G.S. 4 Cunliffe-villas, Manningham, Bradford.
1916. §Weyman, G. Saltwell-road, Low Fell, Gateshead.
1916. \*Wheawill, Charles. 104 Birkby Hall-road, Huddersfield.

Year of  
Election.

1909. †Wheeler, A. O., F.R.G.S. The Alpine Club of Canada, Sidney, B.C., Canada.
1893. \*WHETHAM, W. C. D., M.A., F.R.S. Upwater Lodge, Cambridge.
1888. †Whidborne, Miss Alice Maria. Charanté, Torquay.
1912. †Whiddington, R., M.A., D.Sc. St. John's College, Cambridge.
1913. †Whipp, E. M. 14 St. George's-road, St. Anne's-on-Sea.
1912. \*Whipple, F. J. W., M.A. Meteorological Office, South Kensington, S.W.
1898. \*WHIPPLE, ROBERT S. Scientific Instrument Company, Cambridge.
1859. \*WHITAKER, WILLIAM, B.A., F.R.S., F.G.S. (Pres. C, 1895; Council, 1890-96.) 3 Campden-road, Croydon.
1884. †Whitchee, Arthur Henry. Dominion Lands Office, Winnipeg, Canada.
1897. †Whitcombe, George. The Wotton Elms, Wotton, Gloucester.
1886. †WHITE, A. SILVA. 42 Stevenage-road, S.W.
1908. †White, Mrs. A. Silva. 42 Stevenage-road, S.W.
1911. †White, Miss E. L., M.A. Day Training College, Portsmouth.
1913. §White, Mrs. E. W. Anelgate, Harborne-road, Edgbaston, Birmingham.
1904. †White, H. Lawrence, B.A. 33 Rossington-road, Sheffield.
1885. \*White, J. Martin. Balruddery, Dundee.
1914. †White, Dr. Jean. Prickly Pear Experimental Station, Dulacca, Queensland, Australia.
1910. \*White, Mrs. Jessie, D.Sc., B.A. 49 Gordon-mansions, W.C.
1912. §White, R. G., M.Sc. University College, Bangor, North Wales.
1916. §White, Colonel R. Saxton. Shirley, Jesmond, Newcastle-on-Tyne.
1877. \*White, William. 20 Hillersdon-avenue, Church-road, Barnes, S.W.
1916. §WHITEHEAD, A. N., Sc.D., F.R.S. (Pres. A, 1916), Professor of Applied Mathematics in the Imperial College of Science and Technology, S.W. 97 Coleherne-court, S.W.
1904. †WHITEHEAD, J. E. L., M.A. (Local Sec. 1904.) Guildhall, Cambridge.
1913. †Whitehouse, Richard H., M.Sc. Queen's University, Belfast.
1905. †Whiteley, Miss M. A., D.Sc. Imperial College of Science and Technology, S.W.
1893. §Whiteley, R. Lloyd, F.C.S., F.I.C. Municipal Science and Technical School, West Bromwich.
1907. \*Whitley, E. 13 Linton-road, Oxford.
1905. \*Whitmee, H. B. P.O. Box 470, Durban, Natal.
1891. †Whitmell, Charles T., M.A., B.Sc. Invermay, Hyde Park, Leeds.
1897. †WHITTAKER, E. T., M.A., F.R.S., Professor of Mathematics in the University of Edinburgh.
1901. †Whitton, James. City Chambers, Glasgow.
1913. §WICKSTEED, Rev. PHILIP H., M.A. (Pres. F, 1913.) Childrey, Wantage, Berkshire.
1912. †Wight, Dr. J. Sherman. 30 Schermerhorn-street, Brooklyn, U.S.A.
1889. \*WILBERFORCE, L. R., M.A., Professor of Physics in the University of Liverpool.
1914. †Wilcock, J. L. 9 East-road, Lancaster.
1887. \*WILDE, HENRY, D.Sc., D.C.L., F.R.S. The Hurst, Alderley Edge, Cheshire.
1910. §Wilkins, C. F. Lower Division, Eastern Jumna Canal, Delhi.
1904. †Wilkinson, Hon. Mrs. Dringhouses Manor, York.
1900. §Wilkinson, J. B. Holme-lane, Dudley Hill, Bradford.
1915. \*Willans, J. B. Dolfargan, Kerry, Montgomeryshire.
1913. †Willcox, J. Edward, M.Inst.C.E. 27 Calthorpe-road, Edgbaston, Birmingham.

Year of  
Election.

1903. †Willet, John E. 3 Park-road, Southport.  
 1916. §Willey, F. C., R.N. 5 Clarence-place, Clapton-square, N.E.  
 1904. \*Williams, Miss Antonia. 6 Sloane-gardens, S.W.  
 1916. §Williams, Dr. Ethel. 3 Osborne-terrace, Newcastle-on-Tyne.  
 1905. §Williams, Gardner F. 2201 R-street, Washington, D.C., U.S.A.  
 1883. †Williams, Rev. H. Alban, M.A. Sheering Rectory, Harlow, Essex.  
 1861. \*Williams, Harry Samuel, M.A., F.R.A.S. 6 Heathfield, Swansea.  
 1875. \*Williams, Rev. Herbert Addams. Llangibby Rectory, near Newport, Monmouthshire.  
 1891. §Williams, J. A. B., M.Inst.C.E. 22 Lansdown-place, Cheltenham.  
 1883. \*Williams, Mrs. J. Davies. 5 Chepstow-mansions, Bayswater, W.  
 1888. \*Williams, Miss Katharine I. Llandaff House, Pembroke-vale, Clifton, Bristol.  
 1901. \*Williams, Miss Mary. 6 Sloane-gardens, S.W.  
 1916. §Williams, Miss Maud. 15 Upper Cheyne-row, S.W.  
 1891. †Williams, Morgan. 5 Park-place, Cardiff.  
 1883. †Williams, T. H. 27 Water-street, Liverpool.  
 1877. \*WILLIAMS, W. CARLETON, F.C.S. Broomgrove, Goring-on-Thames.  
 1894. \*Williamson, Mrs. Janora. 18 Rosebery-gardens, Crouch End, N.  
 1910. †Williamson, K. B., Central Provinces, India. Care of Messrs. Grindlay & Co., 54 Parliament-street, S.W.  
 1913. †Willink, H. G. Hillfields, Burghfield, Mortimer, Berkshire.  
 1895. †WILLINK, W. (Local Sec. 1896.) 14 Castle-street, Liverpool.  
 1895. †WILLIS, JOHN C., M.A., D.Sc., F.L.S. 48 Jesus-lane, Cambridge.  
 1896. †WILLISON, J. S. (Local Sec. 1897.) Toronto, Canada.  
 1913. \*Wills, L. J., M.A., F.G.S. 128 Westfield-road, Edgbaston, Birmingham.  
 1899. §Willson, George. Lendarac, Sedlescombe-road, St. Leonards-on-Sea.  
 1899. §Willson, Mrs. George. Lendarac, Sedlescombe-road, St. Leonards-on-Sea.  
 1913. §Wilmore, Albert, D.Sc., F.G.S. Fernbank, Colne.  
 1911. \*Wilmott, A. J., B.A. Natural History Museum, S.W.  
 1911. §Wilmore, Professor N. T. M., D.Sc. The University, Perth, Western Australia.  
 1911. †Wilmore, Mrs. The University, Perth, Western Australia.  
 1901. †Wilson, A. Belvoir Park, Newtownbreda, Co. Down.  
 1878. †Wilson, Professor Alexander S., M.A., B.Sc. United Free Church Manse, North Queensferry.  
 1905. \*Wilson, Captain A. W. P.O. Box 24, Langlaagte, South Africa.  
 1907. †Wilson, A. T. Low Slack, Queen's-road, Kendal.  
 1903. †Wilson, C. T. R., M.A., F.R.S. Sidney-Sussex College, Cambridge.  
 1894. \*Wilson, Charles J., F.I.C., F.C.S. 14 Suffolk-street, Pall Mall, S.W.  
 1904. §Wilson, Charles John, F.R.G.S. Deanfield, Hawick, Scotland.  
 1912. †Wilson, David, M.A., D.Sc. Carbeth, Killearn, N.B.  
 1904. †Wilson, David, M.D. Glenfield, Deighton, Huddersfield.  
 1912. \*Wilson, David Alec. 1 Broomfield-road, Ayr.  
 1900. \*Wilson, Duncan R. 44 Whitehall-court, S.W.  
 1895. †Wilson, Dr. Gregg. Queen's University, Belfast.  
 1914. †Wilson, H. C. Department of Agriculture, Research Station, Werribee, Victoria.  
 1901. †Wilson, Harold A., M.A., D.Sc., F.R.S., Professor of Physics in the Rice Institute, Houston, Texas.  
 1902. \*Wilson, Harry, F.I.C. 32 Westwood-road, Southampton.  
 1879. †Wilson, Henry J., M.P. Osgathorpe Hills, Sheffield.  
 1910. \*Wilson, J. S. 29 Denbigh-street, S.W.  
 1913. †Wilson, Professor J. T., M.B., F.R.S. University of Sydney, Sydney, N.S.W.

Year of  
Election.

1908. †Wilson, Professor James, M.A., B.Sc. 40 St. Kevin's-park, Dartry-road, Dublin.
1879. †Wilson, John Wycliffe. Easthill, East Bank-road, Sheffield.
1901. \*Wilson, Joseph, F.R.M.S. The Hawthorns, 3 West Park-road, Kew Gardens, Surrey.
1908. \*Wilson, Malcolm, D.Sc., F.L.S., Lecturer in Mycology and Bacteriology in the University of Edinburgh. Royal Botanic Gardens, Edinburgh.
1908. §Wilson, Miss Mary. Glenfield, Deighton, Huddersfield.
1909. §Wilson, R. A. Hinton, Londonderry.
1847. \*Wilson, Rev. Sumner. Preston Candover Vicarage, Basingstoke.
1892. †Wilson, T. Stacey, M.D. 27 Wheeley's-road, Edgbaston, Birmingham.
1861. †Wilson, Thomas Bright. Ghyllside, Wells-road, Ilkley, Yorkshire.
1887. §Wilson, W. Battlehillock, Kildrummy, Mossat, Aberdeenshire.
1909. †Wilson, W. Murray. 29 South-drive, Harrogate.
1910. †Wilton, T. R., M.A., Assoc.M.Inst.C.E. 18 Westminster-chambers, Crosshall-street, Liverpool.
1907. §Wimperis, H. E., M.A. 7 Chelsea-court, S.W.
1910. †Winder, B. W. Ceylon House, Sheffield.
1886. †WINDLE, Sir BERTRAM C. A., M.A., M.D., D.Sc., F.R.S., President of University College, Cork.
1863. \*WINWOOD, Rev. H. H., M.A., F.G.S. (Local Sec. 1864.) 11 Cavendish-crescent, Bath.
1905. §Wiseman, J. G., F.R.C.S., F.R.G.S. Stranraer, St. Peter's-road, St. Margaret's-on-Thames.
1914. †Witkiewicz, S. Care of Dr. Malinowski, London School of Economics, Clare Market, W.C.
1913. †Wohlgemuth, Dr. A. 44 Church-crescent, Muswell Hill, N.
1875. †WOLFE-BARRY, Sir JOHN, K.C.B., F.R.S., M.Inst.C.E. (Pres. G, 1898; Council, 1899-1903, 1909-10.) Delahay House, 15 Chelsea Embankment, S.W.
1915. †Wolff, C. E. The Clough, Hale, Cheshire.
1905. †Wood, A., jun. Emmanuel College, Cambridge.
1863. \*Wood, Collingwood L. Freeland, Forgandenny, N.B.
1875. \*Wood, George William Rayner. Singleton Lodge, Manchester.
1878. †WOOD, Sir H. TRUEMAN, M.A. Royal Society of Arts, John-street, Adelphi, W.C.; and Prince Edward's-mansions, Bayswater, W.
1908. †Wood, Sir Henry J. 4 Elsworthy-road, N.W.
1883. \*Wood, J. H. 21 Westbourne-road, Birkdale, Lancashire.
1912. §Wood, John K. 304 Blackness-road, Dundee.
1904. \*WOOD, T. B., M.A. (Pres. M, 1913), Professor of Agriculture in the University of Cambridge. Caius College, Cambridge.
1899. \*Wood, W. Hoffman. Ben Rhydding, Yorkshire.
1901. \*Wood, William James, F.S.A.(Scot.). 266 George-street, Glasgow.
1899. \*Woodcock, Mrs. A. Care of Messrs. Stilwell & Harley, 4 St. James'-street, Dover.
1896. \*WOODHEAD, Professor G. SIMS, M.D. Pathological Laboratory, Cambridge.
1911. §Woodhead, T. W., Ph.D., F.L.S. Technical College, Huddersfield.
1912. \*Wood-Jones, F., D.Sc., Professor of Anatomy in the University of London. New Selma, Epsom, Surrey.
1906. \*Woodland, Dr. W. N. F. Zoological Department, The Muir Central College, Allahabad, United Provinces, India.

Year of  
Election.

1916. §Woodrow, John. Berryknowe, Meikleriggs, Paisley.  
 1904. †Woods, Henry, M.A., F.R.S. Sedgwick Museum, Cambridge.  
 1916. §Woods, Henry Charles. 171 Victoria-street, S.W.  
       WOODS, SAMUEL. 1 Drapers'-gardens, Throgmorton-street,  
       E.C.  
 1887. \*WOODWARD, ARTHUR SMITH, LL.D., F.R.S., F.L.S., F.G.S. (Pres. C,  
 1909; Council, 1903-10, 1915- ), Keeper of the Department  
 of Geology, British Museum (Natural History), Cromwell-  
 road, S.W.  
 1869. \*WOODWARD, C. J., B.Sc., F.G.S. The Lindens, St. Mary's-road,  
 Harborne, Birmingham.  
 1912. †Woodward, Mrs. C. J. The Lindens, St. Mary's-road, Harborne,  
 Birmingham.  
 1866. †WOODWARD, HENRY, LL.D., F.R.S., F.G.S. (Pres. C, 1887;  
 Council, 1887-94.) 13 Arundel-gardens, Notting Hill, W.  
 1894. \*Woodward, John Harold. 8 Queen Anne's-gate, Westminster,  
 S.W.  
 1909. \*Woodward, Robert S. Carnegie Institution, Washington, U.S.A.  
 1908. §WOOLACOTT, DAVID, D.Sc., F.G.S. 8 The Oaks West, Sunder-  
 land.  
 1890. \*Woolcombe, Robert Lloyd, M.A., LL.D., F.I.Inst., F.R.C.Inst.,  
 F.R.G.S., F.R.E.S., F.S.S., M.R.I.A. 14 Waterloo-road,  
 Dublin.  
 1883. \*Woolley, George Stephen. Victoria Bridge, Manchester.  
 1915. \*Woolley, Hermann. Fairhill, Kersal, Manchester.  
 1914. †Woolnough, Professor W. S., D.Sc. University of Western  
 Australia, Perth, Western Australia.  
 1912. \*Wordie, James M., B.A. St. John's College, Cambridge.  
 1863. †Worsley, Philip J. Rodney Lodge, Clifton, Bristol.  
 1901. †Worth, J. T. *Oakenrod Mount, Rochdale.*  
 1908. \*Worthington, James H., M.A., F.R.A.S., F.R.G.S. The Observa-  
 tory, Four-Marks, Alton.  
 1906. †WRAGGE, R. H. VERNON. York.  
 1910. †Wrench, E. G. Park Lodge, Baslow, Derbyshire.  
 1906. †Wright, Sir Almroth E., M.D., D.Sc., F.R.S., Professor of Ex-  
 perimental Pathology in the University of London. 6 Park-  
 crescent, W.  
 1914. †Wright, A. M. Islington, Christchurch, New Zealand.  
 1883. \*Wright, Rev. Arthur, D.D. Queens' College, Cambridge.  
 1909. †Wright, C. S., B.A. Caius College, Cambridge.  
 1914. †Wright, Gilbert. Agricultural Department, The University,  
 Sydney, N.S.W.  
 1874. †Wright, Joseph, F.G.S. 4 Alfred-street, Belfast.  
 1884. †WRIGHT, Professor R. RAMSAY, M.A., B.Sc. Red Gables, Head-  
 ington Hill, Oxford.  
 1904. †Wright, R. T. *Goldieslie, Trumpington, Cambridge.*  
 1911. †Wright, W. B., B.A., F.G.S. 14 Hume-street, Dublin.  
 1903. †Wright, William. The University, Birmingham.  
 1871. †WRIGHTSON, Sir THOMAS, Bart., M.Inst.C.E., F.G.S. Neasham  
 Hall, Darlington.  
 1902. †Wyatt, G. H. 1 Maurice-road, St. Andrew's Park, Bristol.  
 1901. †Wylie, Alexander. Kirkfield, Johnstone, N.B.  
 1902. †Wylie, John. 2 Mafeking-villas, Whitehead, Belfast.  
 1911. †Wyllie, W. L., R.A. Tower House, Tower-street, Portsmouth.  
 1899. †WYNNE, W. P., D.Sc., F.R.S. (Pres. B, 1913), Professor of  
 Chemistry in the University of Sheffield. 17 Taptownville-  
 road, Sheffield.

Year of  
Election.

1901. \*YAPP, R. H., M.A., Professor of Botany in the Queen's University, Belfast.  
 \*Yarborough, George Cook. Camp's Mount, Doncaster.
1894. \*Yarrow, Sir A. F. Homestead, Hindhead, Surrey.
1913. \*Yates, H. James, F.C.S., M.I.Mech.E. Redcroft, Four Oaks, Warwickshire.
1905. †Yerbury, Colonel. Army and Navy Club, Pall Mall, S.W.
1917. §Yorke, Mrs. Constance Eleanor, F.R.G.S. Ladies' Imperial Club, 17 Dover-street, Piccadilly, W.
1909. §Young, Professor A. H. Trinity College, Toronto, Canada.
1904. †Young, Alfred. Selwyn College, Cambridge.
1891. §YOUNG, ALFRED C., F.C.S. 17 Vicar's-hill, Lewisham, S.E.
1905. †Young, Professor Andrew, M.A., B.Sc. South African College, Cape Town.
1909. †Young, F. A. 615 Notre Dame-avenue, Winnipeg, Canada.
1913. \*Young, Francis Chisholm. Smart's Hill, Penshurst, Kent.
1894. \*YOUNG, GEORGE, Ph.D. 46 Church-crescent, Church End, Finchley, N.
1909. §Young, Herbert, M.A., B.C.L., F.R.G.S. Arnprior, Ealing, W.
1901. \*Young, John. 2 Montague-terrace, Kelvinside, Glasgow.
1885. †YOUNG, R. BRUCE, M.A., M.B. 8 Crown-gardens, Dowanhill, Glasgow.
1909. †Young, R. G. University of North Dakota, North Chautauqua, North Dakota, U.S.A.
1901. †Young, Robert M., B.A. Rathvarna, Belfast.
1883. \*YOUNG, SYDNEY, D.Sc., F.R.S. (Pres. B, 1904), Professor of Chemistry in the University of Dublin. 13 Clyde-road, Dublin.
1887. †Young, Sydney. 29 Mark-lane, E.C.
1911. †Young, T. J. College of Agriculture, Holmes Chapel, Cheshire.
1907. \*YOUNG, WILLIAM HENRY, M.A., Sc.D., Hon. Dr. ès Sc. Math., F.R.S., Professor of the Philosophy and History of Mathematics in the University of Liverpool. Epinettes 22, Lausanne, Switzerland.
1903. †Yoxall, Sir J. H., M.P. 67 Russell-square, W.C.

## CORRESPONDING MEMBERS.

Year of  
Election.

1892. Professor Svante Arrhenius. The University, Stockholm. (Bergsgatan 18.)
1913. Professor C. Barrois. Université, Lille, France.
1897. Professor Carl Barus. Brown University, Providence, R.I., U.S.A.
1887. Hofrath Professor A. Bernthsen, Ph.D. Anilfabrik, Ludwigshafen, Germany.
1913. Professor K. Birkeland. Universitet, Christiania.
1890. Professor Dr. L. Brentano. Friedrichstrasse 11, München.
1893. Professor Dr. W. C. Brögger. Universitets Mineralogiske Institute, Christiania, Norway.
1894. Professor D. H. Campbell. Stanford University, Palo Alto, California, U.S.A.
1897. M. C. de Candolle. 3 Cour de St. Pierre, Geneva, Switzerland.
1887. Professor G. Capellini. 65 Via Zamboni, Bologna, Italy.
1913. Professor H. S. Carhart. University of Michigan, Ann Arbor, Michigan, U.S.A.
1894. Emile Cartailhao. 5 rue de la Chaîne, Toulouse, France.
1901. Professor T. C. Chamberlin. Chicago, U.S.A.
1894. Dr. A. Chauveau. 7 rue Cuvier, Paris.
1913. Professor R. Chodat. Université, Geneva.
1887. F. W. Clarke. Care of the Smithsonian Institution, Washington, D.C., U.S.A.
1913. Professor H. Conwentz. Elssholzstrasse 13, Berlin W. 57.
1873. Professor Guido Cora. Via Nazionale 181, Rome.
1889. W. H. Dall, Sc.D. United States Geological Survey, Washington, D.C., U.S.A.
1872. Dr. Yves Delage. Faculté des Sciences, La Sorbonne, Paris.
1901. Professor G. Dewalque. 17 rue de la Paix, Liège, Belgium.
1913. Professor Carl Diener. Universität, Vienna.
1876. Professor Alberto Echer. Florence.
1894. Professor Dr. W. Einthoven. Leiden, Netherlands.
1892. Professor F. Elfving. Helsingfors, Finland.
1901. Professor J. Elster. Wolfenbüttel, Germany.
1913. Professor A. Engler. Universität, Berlin.
1913. Professor Giulio Fano. Istituto di Fisiologia, Florence.
1901. Professor W. G. Farlow. Harvard, U.S.A.
1874. Dr. W. Feddersen. Carolinenstrasse 9, Leipzig.
1913. Professor Chas. Féry. École Municipale de Physique et de Chimie Industrielles, 42 rue Lhomond, Paris.
1886. Dr. Otto Finsch. Altewiekring, No.19b, Braunschweig, Germany.
1894. Professor Wilhelm Foerster, D.C.L. Encke Platz 3A, Berlin, S.W.48.
1901. Professor A. P. N. Franchimont. Leiden, Netherlands.
1894. Professor Léon Fredericq. 20 rue de Pitteurs, Liège, Belgium.
1913. Professor M. von Frey. Universität, Würzburg.
1892. Professor Dr. Gustav Fritsch. Berlinerstrasse 30, Berlin.
1881. Professor C. M. Gariel. 6 rue Edouard Détaillé, Paris.
1901. Professor Dr. H. Geitel. Wolfenbüttel, Germany.



Year of  
Election.

1889. Professor Gustave Gilson. L'Université, Louvain, Belgium.  
 1913. Professor E. Gley. 14 rue Monsieur le Prince, Paris.  
 1889. A. Gobert. 222 Chaussée de Charleroi, Brussels.  
 1884. General A. W. Greely, LL.D. War Department, Washington,  
 U.S.A.  
 1913. Professor P. H. von Groth. Universität, Munich.  
 1892. Dr. C. E. Guillaume. Bureau International des Poids et Mesures,  
 Pavillon de Breteuil, Sèvres.  
 1913. Yves Guyot. 95 rue de Seine, Paris.  
 1876. Professor Ernst Haeckel. Jena.  
 1916. George Ellery Hale. Astrophysical Observatory, Mount Wilson,  
 California, U.S.A.  
 1881. Dr. Edwin H. Hall. 30 Langdon-street, Cambridge, Mass., U.S.A.  
 1913. Professor A. Haller. 10 rue Vauquelin, Paris.  
 1913. Professor H. J. Hamburger. Physiological Institute, Groningen.  
 1893. Professor Paul Heger. 23 rue de Drapiers, Brussels.  
 1894. Professor Ludimar Hermann. Universität, Königsberg, Prussia.  
 1893. Professor Richard Hertwig. Zoologisches Institut, Alte Akademie,  
 Munich.  
 1913. Professor A. F. Holleman. Universiteit, Amsterdam.  
 1887. Dr. Oliver W. Huntington. Cloyne House, Newport, R.I., U.S.A.  
 1884. Professor C. Loring Jackson. 6 Boylston Hall, Cambridge, Mas-  
 sachusetts, U.S.A.  
 1876. Dr. W. J. Janssen. Soldino, Lugano, Switzerland.  
 1881. W. Woolsey Johnson, Professor of Mathematics in the United States  
 Naval Academy, Annapolis, Maryland, U.S.A.  
 1887. Professor C. Julin. 159 rue de Fragnée, Liège.  
 1876. Dr. Giuseppe Jung. Bastioni Vittoria 21, Milan.  
 1913. Professor J. C. Kapteyn. Universiteit, Groningen.  
 1913. Professor A. E. Kennelly. Harvard University, Cambridge,  
 Massachusetts, U.S.A.  
 1884. Baron Dairoku Kikuchi, M.A. Imperial University, Tokyo, Japan.  
 1873. Professor Dr. Felix Klein. Wilhelm-Weberstrasse 3, Göttingen.  
 1894. Professor Dr. L. Kny. Kaiser-Allee 186-7, Wilmersdorf, bei Berlin.  
 1894. Professor J. Kollmann. St. Johann 88, Basel, Switzerland.  
 1913. Professor D. J. Korteweg. Universiteit, Amsterdam.  
 1913. Professor A. Kossel. Physiologisches Institut, Heidelberg.  
 1894. Maxime Kovalevsky. 13 Avenue de l'Observatoire, Paris, France.  
 1913. Ch. Lallemand, Directeur-Général des Mines. 58 Boulevard  
 Emile-Augier, Paris.  
 1872. M. Georges Lemoine. 76 rue Notre Dame des Champs, Paris.  
 1901. Professor Philipp Lenard. Schlossstrasse 7, Heidelberg.  
 1883. Dr. F. Lindemann. Franz-Josefstrasse 12/I, Munich.  
 1887. Professor Dr. Georg Lunge. Rämistrasse 56, Zurich, V.  
 1913. Professor F. von Luschan. Universität, Berlin.  
 1894. Professor Dr. Otto Maas. Universität, Munich.  
 1913. Professor E. Mahaim. Université de Liège, Belgium.  
 1887. Dr. C. A. von Martius. Voss-strasse 8, Berlin, W.  
 1884. Professor Albert A. Michelson. The University, Chicago, U.S.A.  
 1894. Professor G. Mittag-Leffler. Djursholm, Stockholm.  
 1897. Professor Oskar Montelius. St. Paulsgatan 11, Stockholm, Sweden,  
 1913. Professor E. H. Moore. University of Chicago, U.S.A.  
 1897. Professor E. W. Morley, LL.D. West Hartford, Connecticut,  
 U.S.A.  
 1887. E. S. Morse. Peabody Academy of Science, Salem, Mass., U.S.A.  
 1913. Professor F. R. Moulton. University of Chicago, U.S.A.  
 1889. Dr. F. Nansen. Lysaker, Norway.

Year of  
Election.

1894. Professor R. Nasini. Istituto Chimico, Via S. Maria, Pisa, Italy.  
 1913. Professor E. Naville. Université, Geneva.  
 1887. Professor Emilio Noelting. Mühlhausen, Elsass, Germany.  
 1894. Professor H. F. Osborn. Columbia College, New York, U.S.A.  
 1890. Professor W. Ostwald. Linnéstrasse 2, Leipzig.  
 1890. Maffeo Pantaleoni. 13 Cola di Rienzo, Rome.  
 1895. Professor F. Paschen. Universität, Tübingen.  
 1887. Dr. Pauli. Feldbergstrasse 49, Frankfurt a/Main, Germany.  
 1901. Hofrath Professor A. Penck. Georgenstrasse 34-36, Berlin, N.W. 7.  
 1890. Professor Otto Pettersson. Stockholms Hogskola, Stockholm.  
 1894. Professor W. Pfeffer, D.C.L. Linnéstrasse 11, Leipzig.  
 1887. Professor Georg Quincke. Bergstrasse 41, Heidelberg.  
 1868. L. Radlkofer, Professor of Botany in the University of Munich.  
 Sonnenstrasse 7.  
 1913. Professor Reinke. Universität, Kiel.  
 1895. Professor Ira Remsen. Johns Hopkins University, Baltimore,  
 U.S.A.  
 1913. Dr. Hans Reusch. Universitet, Christiania.  
 1897. Professor Dr. C. Richet. 15 rue de l'Université, Paris, France.  
 1896. Dr. van Rijckevorsel. Parklaan 3, Rotterdam, Netherlands.  
 1892. Professor Rosenthal, M.D. Erlangen, Bavaria.  
 1913. Professor A. Rothpletz. Universität, Munich.  
 1913. Professor H. Rubens. Universität, Berlin.  
 1895. Professor Carl Runge. Wilhelm Weberstrasse 21, Göttingen,  
 Germany.  
 1901. General Rykatchew. Ouniversitetskaja-liniia, 1, Petrograd.  
 1913. Dr. C. Schoute. De Biet, Holland.  
 1874. Dr. G. Schweinfurth. Kaiser Friedrichstrasse 8, Berlin.  
 1897. Professor W. B. Scott. Princeton, N.J., U.S.A.  
 1887. Ernest Solvay. 25 rue du Prince Albert, Brussels.  
 1888. Dr. Alfred Springer. 312 East 2nd-street, Cincinnati, Ohio,  
 U.S.A.  
 1881. Dr. Cyparissos Stephanos. The University, Athens.  
 1887. Professor John Trowbridge. Harvard University, Cambridge,  
 Massachusetts, U.S.A.  
 1889. Wladimir Vernadsky. Imperial Academy of Sciences, Petrograd.  
 1913. Professor M. Verworn. Universität, Bonn.  
 1886. Professor Jules Vuylsteke. 21 rue Belliard, Brussels, Belgium.  
 1887. Professor Dr. Leonhard Weber. Moltkestrasse 60, Kiel.  
 1913. Professor Max Weber. Universiteit, Amsterdam.  
 1916. Professor W. H. Welch. Johns Hopkins University, Baltimore,  
 U.S.A.  
 1887. Dr. H. C. White. Athens, Georgia, U.S.A.  
 1887. Professor E. Wiedemann. Erlangen.  
 1887. Professor Dr. R. Wiedersheim. Hansastrasse 3, Freiburg-im-  
 Breisgau, Baden.  
 1913. Professor R. W. Wood. Johns Hopkins University, Baltimore,  
 U.S.A.

LIST OF SOCIETIES AND PUBLIC INSTITUTIONS  
TO WHICH A COPY OF THE REPORT IS PRESENTED.

GREAT BRITAIN AND IRELAND.

- Aberystwyth, National Library of Wales.  
 Belfast, Queen's University.  
 Birmingham, Midland Institute.  
 Bradford Philosophical Society.  
 Brighton Public Library.  
 Bristol Naturalists' Society.  
 —, The Museum.  
 Cambridge Philosophical Society.  
 Cardiff, University College.  
 Chatham, Royal Engineers' Institute.  
 Cornwall, Royal Geological Society of.  
 Dublin, Geological Survey of Ireland.  
 —, Royal College of Surgeons in Ireland.  
 —, Royal Irish Academy.  
 —, Royal Society.  
 —, National Library of Ireland.  
 Dundee, University College.  
 —, Albert Institute.  
 Edinburgh, Royal Society of.  
 —, Royal Medical Society of.  
 —, Scottish Society of Arts.  
 Exeter, Royal Albert Memorial College Museum.  
 Glasgow, Royal Philosophical Society of.  
 —, Institution of Engineers and Shipbuilders in Scotland.  
 Leeds, Institute of Science.  
 —, Philosophical and Literary Society of.  
 Liverpool, Free Public Library.  
 —, Royal Institution.  
 —, The University.  
 London, Admiralty, Library of the.  
 —, Board of Agriculture and Fisheries.  
 —, Chemical Society.  
 —, City and Guilds (Engineering) College.  
 —, Civil Engineers, Institution of.  
 —, Geological Society.  
 —, Geology, Museum of Practical.  
 —, Greenwich Royal Observatory.  
 —, Guildhall Library.  
 —, Institution of Electrical Engineers.  
 —, Institution of Mechanical Engineers.  
 London, Intelligence Office, Central Department of Political Information.  
 —, King's College.  
 —, Linnean Society.  
 —, London Institution.  
 —, London University.  
 —, Meteorological Office.  
 —, Physical Society.  
 —, Royal Anthropological Institute.  
 —, Royal Asiatic Society. [tute.  
 —, Royal Astronomical Society.  
 —, Royal College of Physicians.  
 —, Royal College of Surgeons.  
 —, Royal Geographical Society.  
 —, Royal Institution.  
 —, Royal Meteorological Society.  
 —, Royal Sanitary Institute.  
 —, Royal Society.  
 —, Royal Society of Arts.  
 —, Royal Statistical Society.  
 —, United Service Institution.  
 —, University College.  
 —, War Office, Library.  
 —, Workers' Educational Association. 14 Red Lion Square, W.C.  
 —, Zoological Society.  
 Manchester Literary and Philosophical Society.  
 —, Municipal School of Technology.  
 Middlesex, National Physical Laboratory, Teddington.  
 Newcastle-upon-Tyne, Literary and Philosophical Society.  
 —, Public Library.  
 Norwich, The Free Library.  
 Nottingham, The Free Library.  
 Oxford, Ashmolean Natural History Society.  
 —, Radcliffe Observatory.  
 Plymouth Institution.  
 —, Marine Biological Association.  
 Salford, Royal Museum and Library.  
 Sheffield, University College.  
 Southampton, Hartley Institution.  
 Stonyhurst College Observatory.  
 Surrey, Royal Gardens, Kew.  
 Swansea, Royal Institution of South Wales.  
 Yorkshire Philosophical Society.  
 The Corresponding Societies.

## EUROPE.

Belgian Colonial Office . . . . .	India House, Kingsway, W.C.	Munich . . . . .	University Library.
Berlin . . . . .	Die Kaiserliche Akademie der Wissenschaften.	Naples . . . . .	Royal Academy of Sciences.
Bonn . . . . .	University Library.	— . . . . .	Zoological Station.
Brussels . . . . .	Royal Academy of Sciences.	Paris . . . . .	Association Française pour l'Avancement des Sciences.
Charkow . . . . .	University Library.	— . . . . .	Geographical Society.
Coimbra . . . . .	Meteorological Observatory.	— . . . . .	Geological Society.
Copenhagen . . . . .	Royal Society of Sciences.	— . . . . .	Royal Academy of Sciences.
Dorpat, Russia . . . . .	University Library.	— . . . . .	School of Mines.
Dresden . . . . .	Royal Public Library.	Petrograd . . . . .	University Library.
Frankfort . . . . .	Natural History Society.	— . . . . .	Imperial Observatory.
Geneva . . . . .	Natural History Society.	Pultova . . . . .	Imperial Observatory.
Göttingen . . . . .	University Library.	Rome . . . . .	Accademia dei Lincei.
Grätz . . . . .	Naturwissenschaftlicher Verein.	— . . . . .	Collegio Romano.
Halle . . . . .	Leopoldinisch - Carolinische Akademie.	— . . . . .	Italian Geographical Society.
Harlem . . . . .	Société Hollandaise des Sciences.	— . . . . .	Italian Society of Sciences.
Heidelberg . . . . .	University Library.	— . . . . .	Società Italiana per il Progresso delle Scienze.
Helsingfors . . . . .	University Library.	Rumania . . . . .	Rumanian Association for the Advancement of Science.
Jena . . . . .	University Library.	Spain . . . . .	Asociacion para el Progreso de las Ciencias.
Kazan, Russia . . . . .	University Library.	Stockholm . . . . .	Royal Academy.
Kiel . . . . .	Royal Observatory.	Turin . . . . .	Royal Academy of Sciences.
Kiev . . . . .	University Library.	Upsala . . . . .	Royal Society of Science.
Lausanne . . . . .	The University.	Utrecht . . . . .	University Library.
Leiden . . . . .	University Library.	Vienna . . . . .	The Imperial Library.
Liège . . . . .	University Library.	— . . . . .	Central Anstalt für Meteorologie und Erdmagnetismus.
Lisbon . . . . .	Academia Real des Sciences.	Zurich . . . . .	Naturforschende Gesellschaft.
Milan . . . . .	The Institute.		
Modena . . . . .	Royal Academy.		
Moscow . . . . .	Society of Naturalists.		
— . . . . .	University Library.		

## ASIA.

Agra . . . . .	The College.	Calcutta . . . . .	Medical College.
Bombay . . . . .	Elphinstone Institution.	— . . . . .	Presidency College.
— . . . . .	Grant Medical College.	Ceylon . . . . .	The Museum, Colombo.
— . . . . .	Royal Asiatic Society.	Madras . . . . .	The Observatory.
Calcutta . . . . .	Royal Asiatic Society.	— . . . . .	University Library.
— . . . . .	Hooghly College.	Tokyo . . . . .	Imperial University.

## AFRICA.

Cape Town . . . . .	National Botanic Gardens, Newlands.
— . . . . .	The Royal Observatory.
— . . . . .	South African Association for the Advancement of Science.
— . . . . .	South African Public Library.
Grahamstown . . . . .	Rhodes University College.
Kimberley . . . . .	Public Library.

AMERICA.

Albany .....	The Institute.	Montreal .....	McGill University.
Amherst.....	The Observatory.	New York ...	American Society of Civil Engineers.
Baltimore ....	Johns Hopkins Uni- versity.	— .....	Academy of Sciences.
Boston .....	American Academy of Arts and Sciences.	Ottawa.....	Geological Survey of Canada.
— .....	Boston Society of Natural History.	— .....	Department of Agri- culture.
Buenos Aires..	Argentina Society of Natural Science.	Philadelphia ..	American Philosophi- cal Society.
California.....	The University.	— .....	Franklin Institute.
— .....	Lick Observatory.	— .....	University of Penn- sylvania.
— .....	Academy of Sciences.	Toronto .....	The Observatory.
Cambridge ...	Harvard University Library.	— .....	The Canadian Insti- tute.
Chicago .....	American Medical Association.	— .....	The University.
— .....	Field Museum of Natural History.	Uruguay.....	General Statistical Bureau and Library, Montevideo.
Edmonton....	University of Alberta.	Washington...	Board of Agriculture.
Guelph .....	Ontario Agricultural College.	— .....	Bureau of Ethnology.
Kingston .....	Queen's University.	— .....	Bureau of Standards, Department of Com- merce and Labour.
Manitoba ....	Historical and Scien- tific Society.	— .....	Coast and Geodetic Survey.
— .....	The University.	— .....	Library of Congress.
Massachusetts	Marine Biological Laboratory, Woods Hole.	— .....	Naval Observatory.
Mexico .....	Sociedad Cientifica 'Antonio Alzate.'	— .....	Smithsonian Institu- tion.
Missouri .....	Botanical Garden.	— .....	United States Geolo- gical Survey of the Territories.
Montreal .....	Council of Arts and Manufactures.		

AUSTRALIA.

Adelaide .....	Public Library of South Australia.
— .....	Royal Geographical Society.
— .....	The University.
Brisbane .....	Queensland Museum.
— .....	Queensland Public Library.
Melbourne .....	Public Library.
Sydney .....	Public Works Department.
— .....	Australian Museum.
— .....	Library, Department of Mines.
Tasmania .....	Royal Society.
Victoria.....	The Colonial Government.

NEW ZEALAND.

Canterbury .....	The Museum.
Wellington .....	New Zealand Institute (Dominion Museum).





