

UC-NRLF



SB 808 503

RHYTHMICAL PULSATION
IN
SCYPHOMEDUSÆ

BY
ALFRED G. MAYER

sided, will remain the same as it was before the radiating cuts were made. Moreover, its excited rate, due to being lifted out of water and dropped back, remains the same as it was before the cuts were made. On the other hand, cuts designed to successively reduce the area of the sub-umbrella tissue enervated by a sense-organ (such as are shown in fig. 2, A and B) usually cause the normal rate of pulsation to decline. The *excited rates*, however, are less influenced by reduction of area, small pieces sometimes pulsating almost as rapidly as large ones, but the *duration* of the excitement displayed by small pieces is much reduced. For example, in the A series of figure 2—

	Area.	Normal rate per minute.	Excited rate per minute.
A ₁	280	17	32
A ₂	54	12	40
A ₃	1	6	11

In the B series the relative areas and rates were as follows:

	Area.	Normal rate per minute.	Excited rate per minute.
B ₁	271	27	50
B ₂	153	14-20	50
B ₃	5	17	48
B ₄	2	14	19
B ₅	1	14-20	35

The above results are quite similar to those of Romanes upon *Aurelia*, and are opposed to the conclusion of Eimer that severed portions of the disk pulsate at rates approximately proportionate to their respective areas.

It is interesting to observe that if we stimulate a Medusa into prolonged and active pulsation at an "excited" rate and then cut out the marginal sense-organs, each sense-organ, together with the piece of tissue attached to it, instantly subsides into a *slow* rate of pulsation, never faster than the average unexcited rate of the entire Medusa. Moreover, these pieces with sense-organs attached can not immediately be stimulated into a display of excitement, although after an interval of time they will readily respond and exhibit an excited rate commensurable with that of the perfect Medusa. As we have seen, the display of "excitement" is a function of the undifferentiated tissue of the sub-umbrella, and it appears that the excited rate of the Medusa may be maintained by the influence of the general sub-umbrella tissue

upon the sense-organs even after the sense-organs have become too exhausted to themselves maintain an "excited" rate. Moreover, if we stimulate the sub-umbrella surface by touching it repeatedly with a crystal of K_2SO_4 the disk responds by active contractions and forces the sense-organs to respond at the same rate. Then after the stimulus is withdrawn the sense-organs are found to have been exhausted by the contractions of the disk and can not again resume pulsation until after a long interval of rest.

Direct evidence showing that the sub-umbrella may exert a controlling influence on all parts of the sensory tissues of the Medusa is also afforded by the following experiment: If we cut off the basal plate with the 8 mouth-arms, the mouth-arms remain normally expanded in sea-water. If now we place the mouth-arms in a solution which resembles sea-water, but lacks potassium, the arms contract into a close bunch, and will *not again expand* as long as they remain in the solution. If, however, we place a perfect Medusa in the solution it exhibits periods of active pulsation alternating with periods of rest. Immediately *after* it comes to rest its mouth-arms contract into a close bunch, but they *always expand* again as soon as the Medusa resumes pulsation. It will be remembered that Romanes showed that removal of the margin of the bell in *Sarsia* caused the manubrium to elongate and lose its muscular tonus. He also found that in *Sarsia* stimulation of the sub-umbrella caused the manubrium to contract, and that the manubrium of *Tiaropsis indicans* would apply its mouth to any stimulated part of the sub-umbrella, provided the stimulus could travel radially inward from the stimulated spot to the manubrium. Otherwise the manubrium executed ill-directed or wandering movements.

We will soon show that any difference between the physiological action of the marginal sense-organs and that of the general sensory tissue of the sub-umbrella is one of degree, not of kind.

CONTROL OVER PULSATION EXERCISED BY THE MARGINAL SENSE-ORGANS.

Romanes found that the potency of the marginal sense-organ attached to a segment of the disk has more to do with its rate of pulsation than has the size of the segment; nevertheless small segments usually pulsate slower than large ones.

In *Cassiopea xamachana* there are 13 to 23 marginal sense-organs, and I find that the average rate of the perfect Medusa is apt to be the same as the rate of its *most rapidly* working sense-organ. As Romanes saw in *Aurelia*, the sense-organs tend to initiate stimuli at various

LIBRARY
UNIVERSITY OF CALIFORNIA
DAVIS

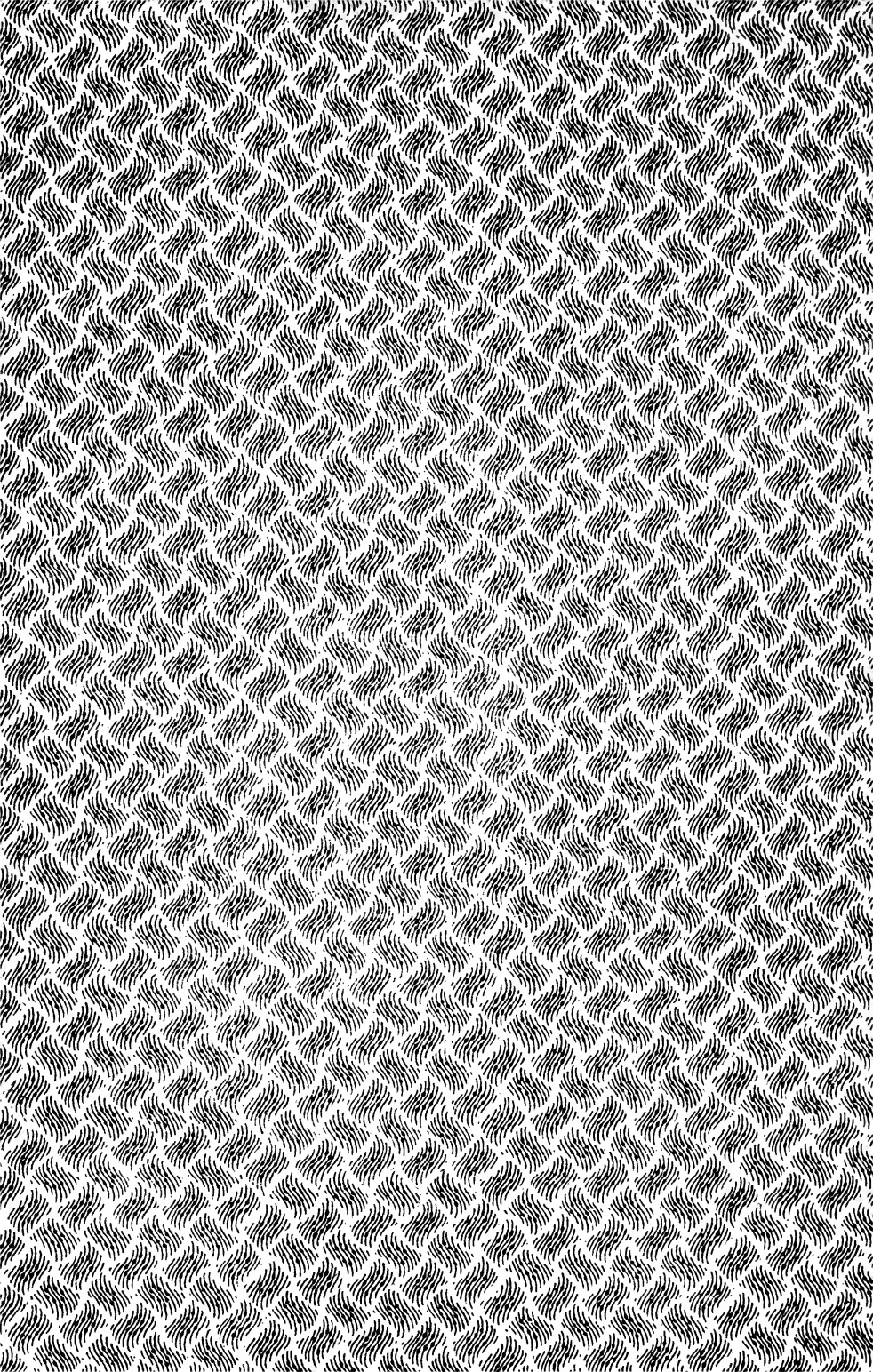

LIBRARY
UNIVERSITY OF CALIFORNIA
DAVIS

Digitized by the Internet Archive
in 2007 with funding from
Microsoft Corporation

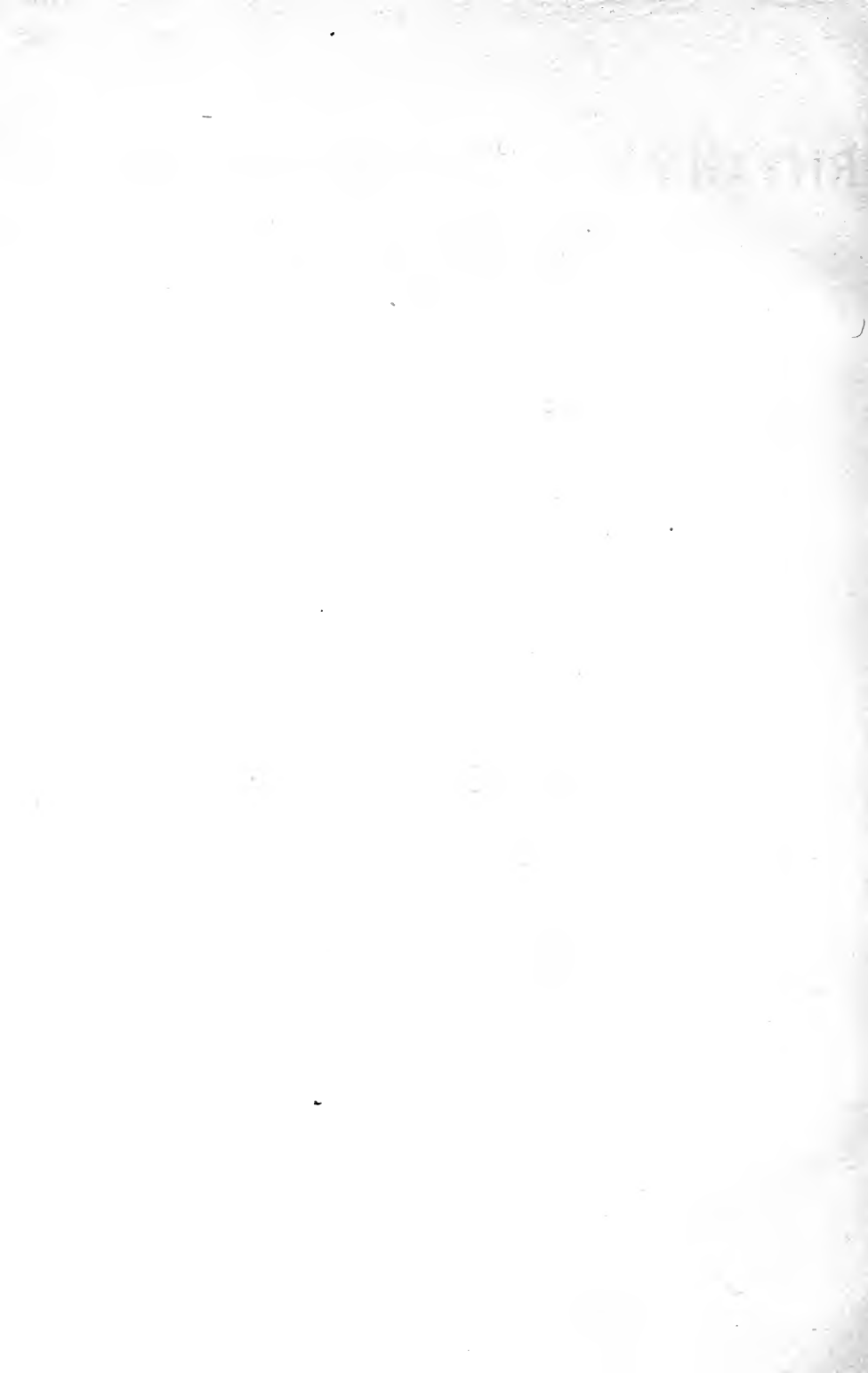

RHYTHMICAL PULSATION IN SCYPHOMEDUSÆ

BY

ALFRED G. MAYER

Director of Department of Marine Biology of the
Carnegie Institution of Washington,
Tortugas, Florida

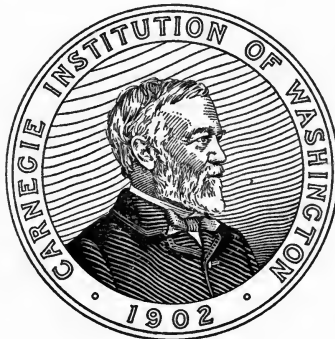

WASHINGTON, D. C.

Published by the Carnegie Institution of Washington

1906

CARNEGIE INSTITUTION OF WASHINGTON

PUBLICATION NO. 47

FROM THE PRESS OF
THE WILKENS-SHEIRY PRINTING CO
WASHINGTON, D. C.

RHYTHMICAL PULSATION IN ANIMALS.

1. PULSATION OF JELLYFISHES, ARMS OF LEPAS, HEART OF SALPA AND OF LOGGERHEAD TURTLE.

I. CONCLUSIONS NEW TO SCIENCE.

1. If we cut off the marginal sense-organs of the scyphomedusa *Cassiopea*, the disk* becomes paralyzed and does not pulsate in sea-water. The disk will pulsate in sea-water, however, if we make either a single ring or a series of concentric broken-ring-like cuts through the muscular tissue of the sub-umbrella. Then upon momentarily stimulating the disk in any manner, it suddenly springs into rapid, rhythmical pulsation so regular and sustained as to recall the movement of clockwork.

Pulsation will not start unless the disk be momentarily stimulated, as by a mechanical or electrical shock or by a single touch with a crystal of K_2SO_4 , but once started it continues indefinitely in normal sea-water without further external stimulation.

The waves of pulsation all arise from the stimulated point, and the labyrinth of sub-umbrella tissue around this center must form a closed circuit. It is not necessary that the cuts through the sub-umbrella tissue of the disk be concentric circles, for any shape will pulsate which allows contraction waves to travel through tissue forming a closed circuit from the stimulated center and back to this center. When each wave returns to the center it is reinforced and again sent out through the circuit; and thus the center sustains the pulsation.

NOTE.—It is a pleasure to express my gratitude to those who have aided me in the prosecution of this research. To Prof. H. S. Jennings for his kindness in sending to me lists of the coefficient i for the making of isotonic solutions; to Dr. Leon J. Cole and Dr. Charles Zeleny for important suggestions and criticisms; to Mr. Davenport Hooker for collecting *Gonionemus* and *Dactylometra*, and to Prof. H. F. Perkins for aid in collecting *Cassiopea* at Tortugas; to Professors Ulrich Dahlgren and Edward L. Mark for instruction and aid.

*In this paper the term "disk" will be used to designate Medusæ from which the marginal sense-organs have been excised; while the term "Medusa" will designate the normal perfect animal.

The pulsating labyrinth may be simplified after the rhythmic movement has started, by cutting parts of it away, or cuts may be made in such manner as to increase its complexity. Any cut which breaks the circuit, however, stops the wave of pulsation, and continuous movement can not again be started.

The rate of pulsation of the disk is fully twice as fast as that of the normal perfect Medusa. This rate remains constant in the pulsating disk, and when pulsation ceases the movement stops *instantly*, never gradually. The rate of pulsation in disks deprived of marginal sense-organs depends not upon the area of the tissue forming the circuit, but only upon the length of the circuit. Short circuits pulsate more rapidly than do long ones. In this respect it differs from the control normally exercised by the marginal sense-organs; for small pieces of tissue with a marginal sense-organ attached pulsate slower than large ones. Moreover, when a sense-organ is present, tissue of any shape will pulsate even if its shape does not form a closed circuit.

The disks of *Aurelia* and *Dactylometra*, if cut as described above, will pulsate as does the disk of *Cassiopea*.

These experiments show that the rhythmical pulsation in Medusæ must arise from a definite center or centers, but this center may be established at any point in the muscular layer of the sub-umbrella. Once established it remains at a fixed point, while the disk continues to pulsate. Sustained pulsation *in disks* occurs only in tissue forming a complete circuit, and depends upon an electric transmission of energy, and the pulsation is self-sustaining (*i.e.*, sustained by internal stimuli) once it be started by an *external, momentary stimulus*.*

2. If normal perfect Medusæ be lifted out of water and then thrown back, the rate and amplitude of their pulsation suddenly increases. Pulsating disks react in a similar manner, but in their case the *amplitude* only increases, the rate remaining practically constant. The presence of marginal sense-organs is therefore not necessary for the display of "excitement."

3. The stimulus which causes pulsation is transmitted by the diffuse nervous or epithelial elements of the sub-umbrella. Newly regenerated sub-umbrella tissue, which lacks muscular elements and can not itself contract, will still serve as a bridge to transmit the stimulus which causes contraction in muscular tissue attached to but

* Professor W. T. Porter (1897) found that any part of the ventricle of the mammalian heart (heart of the dog) will beat for hours if supplied with defibrinated blood through its nutrient artery. Isolated portions of the heart of the hag-fish continue to beat rhythmically for hours even in the absence of nutrition. (See A. J. Carlson, 1905, Amer. Journ. Physiol., p. 220.)

beyond the bridge. In this connection, Carlson has demonstrated that the stimulus which causes the pulsation of the heart of *Limulus* is nervous in nature.

4. The paralyzed disk of *Cassiopea* is stimulated into temporary pulsation by all salts of potassium, sodium, lithium, barium, iodine, bromine, platinum, weak acids (hydrogen), ammonia, and glycerin. Magnesium, calcium, strontium, urea, and dextrose do not stimulate the disk, and produce no contraction.

5. The *sodium chloride* of the sea-water is the chief stimulant to pulsation in *Cassiopea*, while *magnesium* is the chief restrainer of pulsation, and counteracts the influence of the sodium chloride. Thus *Cassiopea* will pulsate in a pure $\frac{5}{8}n$ NaCl solution for more than half an hour, but usually comes to rest in less than two minutes in a solution containing the amounts and proportions of NaCl and magnesium found in sea-water.

I find also that the heart of *Salpa democratica*, the branchial arms of *Lepas*, and the heart of the embryo loggerhead turtle pulsate actively in solutions containing only NaCl, K, and Ca, *magnesium* being absent. Magnesium *inhibits* pulsation in all of these cases, as it does also in *Cassiopea*.

The general rôle of NaCl, K, and Ca in all of the above cases is to combine to form a powerful stimulant producing an abnormally energetic pulsation, which, however, can not continue indefinitely; and *magnesium* is necessary to control and reduce this stimulus so that the pulsating organ is merely upon the threshold of stimulation.

A Ringer's solution is an optimum combination of NaCl, K, and Ca, and is only a stimulant, not an inorganic food, as has been commonly assumed. The organism must in time become exhausted under the influence of this stimulant unless a certain proportion of magnesium be present to restrain its action. Indeed, Ringer's solution probably acts by withdrawing magnesium ions by osmosis, and replacing them by a stimulant composed of salts of Na, K, and Ca. Magnesium is therefore a most important element in controlling and sustaining pulsation. If magnesium be precipitated in the pulsating *Cassiopea*, the NaCl, K, and Ca immediately produce a violent pulsation which soon passes into sustained tetanus, and all movement ceases in cramp-like contraction.*

* Loeb, J. 1906; Journ. Biological Chemistry, vol. 1, p. 331; finds that in the hydro-medusa *Polyorchis* the mouth and tentacles are permanently contracted in any solution which lacks magnesium; and that magnesium serves to relax the muscles of the bell, thus counteracting the tetanus caused by other constituents of the sea-water and guaranteeing the relaxation after a systole.

The *calcium* of the sea-water *assists* the NaCl to resist the retarding effects of magnesium. Thus *Cassiopea* will pulsate from half an hour to an hour in a solution containing the amounts and proportions of NaCl, *magnesium*, and *calcium* found in sea-water, but usually ceases to pulsate in less than two minutes in a solution containing only the NaCl and *magnesium*.

Unlike calcium, *potassium* does *not* assist the NaCl to overcome the stupefying influence of the *magnesium*.* Thus *Cassiopea* ceases to pulsate almost as quickly in a solution containing NaCl, *magnesium*, and *potassium* of sea-water as it does in a solution containing only the NaCl and *magnesium*.

The potassium of sea-water serves, however, to stimulate pulsation in *connection with both* calcium and NaCl. Thus *Cassiopea* pulsates only from 20 to 120 minutes and at about a normal rate in NaCl + K₂SO₄, or in NaCl + KCl, whereas it pulsates for more than three hours at fully twice its normal rate in NaCl + K₂SO₄ + CaSO₄, or NaCl + KCl + CaCl₂.

We see, then, that the NaCl, K, and Ca of the sea-water unite in stimulating pulsation and in resisting the stupefying effect of the Mg. All four salts conjointly produce, in sea-water, an indifferent, or balanced, fluid which neither stimulates nor stupefies the disk of *Cassiopea*, and permits a recurring internal stimulus to produce rhythmic movement.

6. *Cassiopea* does not pulsate when its marginal sense-organs are removed, simply because the sea-water does not stimulate it. If stimulated in sea-water, in any manner, it readily pulsates. This is also true of *Gonionemus*, and Loeb's statement that both the K and Ca of sea-water inhibit pulsation is not supported; for the center of *Gonionemus* will pulsate actively, though temporarily, in sea-water whenever it is touched by a crystal of any *potassium salt*, or otherwise stimulated.†

On the other hand, the disks of *Aurelia* and *Dactylometra* begin to pulsate in sea-water in a few minutes, as soon as they recover from the shock of the operation resulting in the loss of their marginal sense-organs. Unlike *Cassiopea* and *Gonionemus*, both *Aurelia* and *Dactylometra* are weakly stimulated by the sea-water *as a whole* and pulsate almost immediately after the removal of their margins.

*The general anesthetic effect of magnesium has been well known since the researches of Tullberg, 1892; Archiv. Zool. Exper. et Gen., Tome x, p. 11.

†As a matter of fact, the disk of *Gonionemus* is often seen to give isolated pulsations, at irregular intervals, in sea-water without apparent external stimulation. (See Yerkes, 1902.)

The disk of *Cassiopea* usually pulsates spontaneously in an irregular manner, immediately after the removal of its marginal sense-organs, if it be placed in a solution containing NaCl, NaCl + KCl, NaCl + CaCl₂, or NaCl + KCl + CaCl₂ in the amounts and proportions found in sea-water; but it will not pulsate in any solution which contains *magnesium*.

7. The central disk of *Cassiopea*, if set into pulsation, will pulsate longer than an hour in a solution resembling sea-water but lacking calcium, whereas the normal perfect Medusa, or parts of the margin containing sense-organs, cease to pulsate in this solution in less than six minutes. The marginal sense-organs can not send forth stimuli producing contractions unless they be *constantly supplied* with calcium from the sea-water, whereas the sub-umbrella tissue of the disk itself is relatively independent of the calcium of the sea-water.

On the other hand, both the disk and the perfect Medusa will pulsate in sea-water saturated with CaSO₄.

8. The normal *Cassiopea* Medusa will pulsate fully three times as long in a solution of Na₂SO₄ containing the same amount of sodium as is found in sea-water as it will in a solution of Na₂SO₄ isotonic with sea-water. This indicates that the amount and proportion of sodium in the sea-water is more important to pulsation than is its osmotic property.

9. The contractions of the heart of the loggerhead turtle are conducted and maintained exclusively by the thin peripheral muscular part of the wall of the heart, the thick cavernated tissue of the heart being passive. Moreover, the outer muscular part of the heart's wall is a better electrical conductor than is the cavernated tissue. A similar condition is seen in *Cassiopea*, where the thin sub-umbrella tissue of the disk is the only part which conducts and maintains the stimulus for pulsation, and is a better electrical conductor than is the thick gelatinous substance of the disk.

10. The chief results of the paper are the discovery of a new method of restoring pulsation in paralyzed Medusæ, and also that *magnesium* plays a most important rôle in restraining, controlling, and prolonging pulsation in animal organisms.

In *Cassiopea* the ectodermal, epithelial, or diffuse nervous elements of the sub-umbrella transmit the stimulus which produces rhythmical contraction.

Rhythmical pulsation can be maintained only when a stimulus and an inhibitor counteract one another, and cause the organism to be upon the threshold of stimulation; thus permitting weak *internal* stimuli to promote periodic contractions.

MINOR CONCLUSIONS.

There are certain minor conclusions, mainly confirmations or amplifications of the excellent work of Romanes upon *Scyphomedusæ*.

In *Cassiopea* the sub-umbrella and mouth-arms are the only parts which respond to mechanical or chemical stimuli. The ex-umbrella is wholly insensitive.

There is no essential difference in kind between the physiological action of the sense-organs, in pulsation, and that of any other part of the sub-umbrella.

Cassiopea will live for more than a month in absolute darkness. Its plant cells then degenerate, but the Medusa does not suffer; hence its vitality is not dependent upon the commensal plant cells within its tissues.

Starved Medusæ will shrink to about one-sixteenth their initial volume and still survive. They will live in brackish water containing 75 per cent fresh water better than they will if we maintain the amounts and proportions of calcium and potassium, merely reducing the amounts of NaCl and magnesium of the sea-water.

The fluids of the gastro-vascular space and of the body of the Medusa are only slightly alkaline, while the sea-water at Tortugas is decidedly alkaline.

The sense-organs tend to send out contraction stimuli at various rates, but the fastest working sense-organ controls the Medusa.

Excitement of the disk forces the sense-organs to maintain a higher rate of pulsation than they are capable of maintaining if cut off, and it is evident, from other experiments, that the disk reacts reciprocally upon the sense-organs, stimulating them into activity.

Small pieces of the disk, enervated by sense-organs, pulsate slower than large ones.

Small *young* Medusæ pulsate faster than large *old* ones.

The sub-umbrella surface of the disk exercises a reflex control over both sense-organs and mouth-arms.

Repeated stimulation of any one part of the disk finally tires the stimulated place so that it ceases to respond. Other parts of the disk still respond as readily as did the tired place in the first instance.

Having stated the principal conclusions, we will now proceed to give a detailed account of the experiments upon *Cassiopea*, *Lepas*, *Salpa*, and the loggerhead turtle.

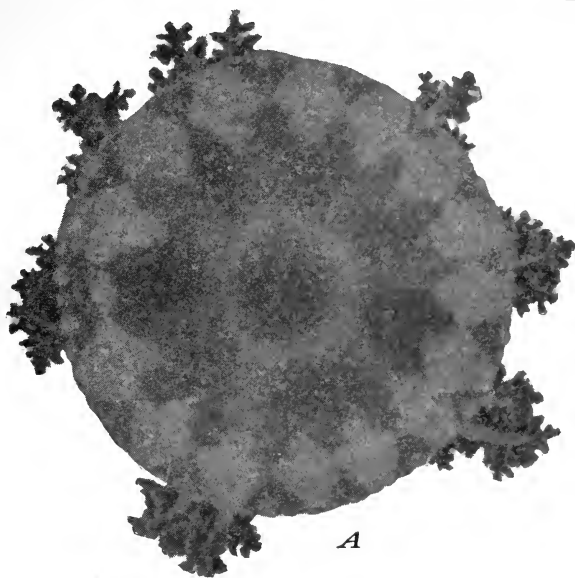
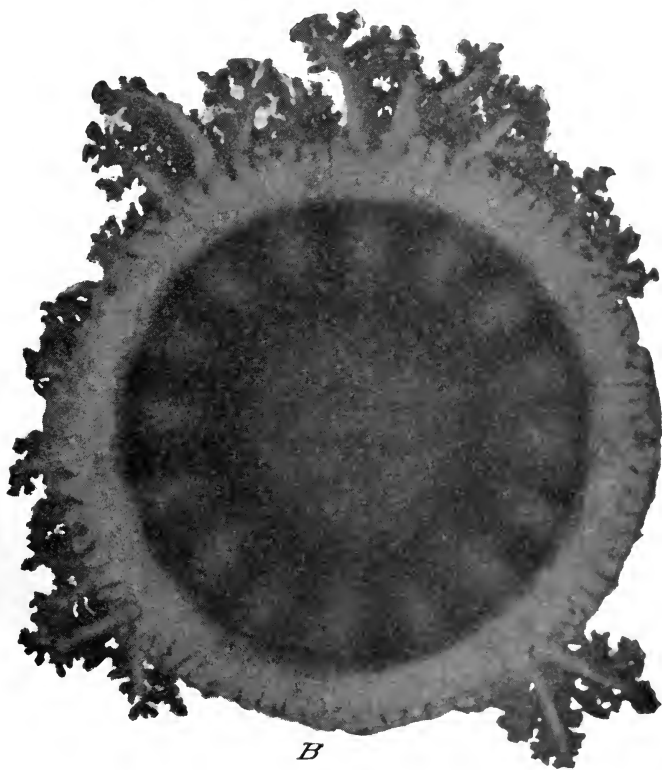
*A**B*

Aboral views of *Cassiopea xamachana* Bigelow. From life. Natural size.

Above, rare, small variety. This bears a close superficial resemblance to the common *Cassiopea ndrosia* of the Fiji Islands.
(See Agassiz and Mayer, 1899, Bull. Mus. Comp. Zool. at Harvard Coll., vol. 32, p. 175, pl. 14.)
Below, the common variety.

II. PULSATION OF CASSIOPEA IN SEA-WATER.

INTRODUCTION—NORMAL MOVEMENTS.

The rhizostomous Scyphomedusa *Cassiopea xamachana* (plates I, II), is very abundant during spring and summer in the salt-water moat of Fort Jefferson, at Tortugas, Florida. It was described by Bigelow (1892, 1900) from a salt-water lagoon in Jamaica, and also under the name of *Cassiopea frondosa* by Fewkes (1883), who found it at the Tortugas.

The Medusæ are usually found gathered in clusters upon the weedy bottom of the moat in water about four feet deep. They lie with the aboral side of the disk pressed downward upon the bottom, and with the 8 mouth-arms, with their numerous suctorial mouths, spread out above. A sucker-like concavity on the aboral side of the disk allows the Medusa to adhere with considerable strength to the bottom or sides of an aquarium, and the tenacity of its hold is still further enhanced by the rhythmical movement of the disk, which beats with considerable regularity, thus tending to hold the bell firmly against its fastening, and also to drive a current of water out over the mouth-arms.

If moved from its normal position and placed in the water with its disk uppermost and arms downward, the rhythmical beating of the disk causes it to swim upward, but if the water be of considerable depth it soon topples over and thus swims downward to the bottom or reaches the side of the aquarium. If, however, it should reach the surface, the concavity at the center of the aboral side of the disk often serves to permit the surface tension to hold the Medusa upon the surface, where it may float for a long time, pulsating normally with the concavity relatively dry, although lower than the general surface of the water.

The Medusa pulsates with a regular rhythmical movement, pauses or irregularities in the rhythm being exceptional. Occasionally, however, its rate suddenly increases, with or without apparent cause, and the pulsation may become so active as to cause the Medusa to break away from its anchorage and glide over the bottom. A regular unexcited movement is, however, often maintained for hours at a time, and in general this rate of pulsation is faster in small than in large Medusæ, as will appear from table 1, on page 8.

The relatively rapid rate of small Medusæ is probably due to their being young and possessed of more vitality than are the large, old animals; for not only do small Medusæ regenerate lost parts more readily, but we also find that specimens which have become reduced in size through starvation pulsate at a slower rate than young and

well-fed Medusæ of the same size. Thus one *Cassiopea* was starved for three months, and the diameter of its disk shrank from 78 to 21 millimeters, while at the same time its rate of pulsation declined from about 40 to 16 per minute. It is also interesting to observe that if we cut off the margins of the disks of Medusæ of various sizes, the severed rims of the small Medusæ pulsate at a more rapid rate than do those of the large Medusæ, although in both cases this rate is slower than that of the uninjured Medusa.

TABLE I.—Relation between the rates of pulsation and the diameters of the disks in Medusæ of *Cassiopea xamachana*.

Diameter of Medusa in millimeters.	No. of pulsations per minute.	Diameter of Medusa in millimeters.	No. of pulsations per minute.	Diameter of Medusa in millimeters.	No. of pulsations per minute.
13	78	28	39-55	62	29
15	82-86	28.5	16-23	63	35
16	94-111	30	53-63	82	40-50
18	68	31	55-61	84	28-39
20	36	32	58-62	90	16-28
20.5	45-65	36	42	102	20-21
22	60	42	51-54	107	23-24
23	44-71	46	45-46	118	7
23.5	40	47	43-36	124	12-16
26	43-52	50	27	136	9-12
27	41-56	57	36-37	153	7

EXCITEMENT.

As we have said, the pulsating Medusæ occasionally exhibit a sudden increase in their rate and amplitude of pulsation without apparent cause. This can, however, be invariably brought about as a response to any stimulus, such as a water current, a mechanical shock, or the introduction of some irritating chemical into the water. When lifted wholly or partially out of water, and replaced, the Medusæ pulsate at about twice their normal rate for two or three minutes, and the amplitude of their pulsations is also increased. Even small fragments of the disk containing a marginal sense-organ will usually display this excitement, although the duration of the period of excitement is shorter for small than for large pieces, and their rate of pulsation slower.

However, the presence of marginal sense-organs is not necessary for this "excitement," for, as we shall soon show, we have succeeded in causing disks deprived of marginal sense-organs to pulsate constantly and regularly in sea-water; and if such disks be pinched or lifted out of water or otherwise disturbed the *amplitude* of their pulsations becomes suddenly increased, while the *rate* remains practically constant. In normal uninjured Medusæ both rate and amplitude increase,

but as we shall see, disks without sense-organs pulsate at the maximum rate at which their tissue is capable of transmitting the wave of pulsation, and they can therefore exhibit "excitement" only by an increase in amplitude.

It is worthy of note that if the forceps used to stimulate the Medusa be made to seize upon only a small area of tissue, the Medusa will not respond, but on bringing a larger area between the forceps the response is sudden and violent. In this connection it will be recalled that Romanes showed that the bell of *Sarsia*, when deprived of its margin, will respond to mechanical shocks by pulsations, each stimulus usually giving rise to one or two pulsations, and this is also true of the paralyzed disk of *Cassiopea*. We must conclude that the presence of marginal sense-organs is not necessary for the display of that sudden increase in activity which we have called "excitement," and that this response may come from many or all parts of the undifferentiated tissue of the sub-umbrella.*

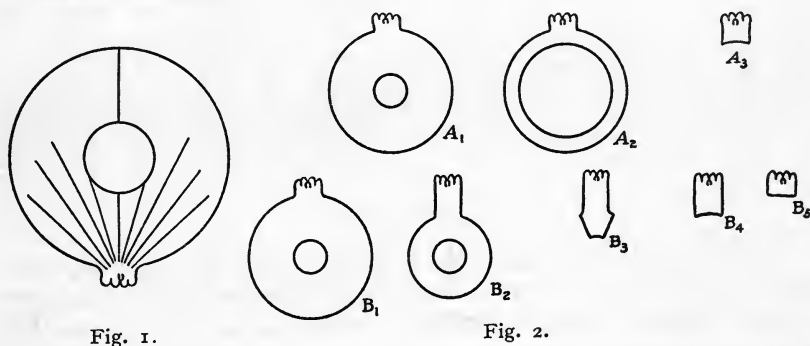

Fig. 1.

Fig. 2.

Romanes showed that in *Aurelia* annular cuts separating the margin from the center of the disk caused the rhythm to become slower, and he was led to suspect (1885, p. 163) that a stimulus of an afferent character emanates from all parts of the sensory surfaces of the sub-umbrella to the marginal sense-organs, although of this he had no direct proof. I think we can prove that this is the case in *Cassiopea*, for if we cut off all but one marginal sense-organ, and then make cuts through the sub-umbrella tissue (fig. 1) radiating outward from the sense-organ and therefore not interfering with any stimulus which may travel by the shortest path from any point in the disk to the sense-organ, the final rate of pulsation, after the excitement due to the operation has sub-

* It is interesting to observe that Bancroft and Esterly (1903) find that while contractions normally originate from the ganglionated ends of the heart of *Ciona*, they may originate from any other region.

sided, will remain the same as it was before the radiating cuts were made. Moreover, its excited rate, due to being lifted out of water and dropped back, remains the same as it was before the cuts were made. On the other hand, cuts designed to successively reduce the area of the sub-umbrella tissue enervated by a sense-organ (such as are shown in fig. 2, A and B) usually cause the normal rate of pulsation to decline. The *excited rates*, however, are less influenced by reduction of area, small pieces sometimes pulsating almost as rapidly as large ones, but the *duration* of the excitement displayed by small pieces is much reduced. For example, in the A series of figure 2—

	Area.	Normal rate per minute.	Excited rate per minute.
A ₁	280	17	32
A ₂	54	12	40
A ₃	1	6	11

In the B series the relative areas and rates were as follows:

	Area.	Normal rate per minute.	Excited rate per minute.
B ₁	271	27	50
B ₂	153	14-20	50
B ₃	5	17	48
B ₄	2	14	19
B ₅	1	14-20	35

The above results are quite similar to those of Romanes upon *Aurelia*, and are opposed to the conclusion of Eimer that severed portions of the disk pulsate at rates approximately proportionate to their respective areas.

It is interesting to observe that if we stimulate a Medusa into prolonged and active pulsation at an "excited" rate and then cut out the marginal sense-organs, each sense-organ, together with the piece of tissue attached to it, instantly subsides into a *slow* rate of pulsation, never faster than the average unexcited rate of the entire Medusa. Moreover, these pieces with sense-organs attached can not immediately be stimulated into a display of excitement, although after an interval of time they will readily respond and exhibit an excited rate commensurable with that of the perfect Medusa. As we have seen, the display of "excitement" is a function of the undifferentiated tissue of the sub-umbrella, and it appears that the excited rate of the Medusa may be maintained by the influence of the general sub-umbrella tissue

upon the sense-organs even after the sense-organs have become too exhausted to themselves maintain an "excited" rate. Moreover, if we stimulate the sub-umbrella surface by touching it repeatedly with a crystal of K_2SO_4 the disk responds by active contractions and forces the sense-organs to respond at the same rate. Then after the stimulus is withdrawn the sense-organs are found to have been exhausted by the contractions of the disk and can not again resume pulsation until after a long interval of rest.

Direct evidence showing that the sub-umbrella may exert a controlling influence on all parts of the sensory tissues of the Medusa is also afforded by the following experiment: If we cut off the basal plate with the 8 mouth-arms, the mouth-arms remain normally expanded in sea-water. If now we place the mouth-arms in a solution which resembles sea-water, but lacks potassium, the arms contract into a close bunch, and will *not again expand* as long as they remain in the solution. If, however, we place a perfect Medusa in the solution it exhibits periods of active pulsation alternating with periods of rest. Immediately *after* it comes to rest its mouth-arms contract into a close bunch, but they *always expand* again as soon as the Medusa resumes pulsation. It will be remembered that Romanes showed that removal of the margin of the bell in *Sarsia* caused the manubrium to elongate and lose its muscular tonus. He also found that in *Sarsia* stimulation of the sub-umbrella caused the manubrium to contract, and that the manubrium of *Tiaropsis indicans* would apply its mouth to any stimulated part of the sub-umbrella, provided the stimulus could travel radially inward from the stimulated spot to the manubrium. Otherwise the manubrium executed ill-directed or wandering movements.

We will soon show that any difference between the physiological action of the marginal sense-organs and that of the general sensory tissue of the sub-umbrella is one of degree, not of kind.

CONTROL OVER PULSATION EXERCISED BY THE MARGINAL SENSE-ORGANS.

Romanes found that the potency of the marginal sense-organ attached to a segment of the disk has more to do with its rate of pulsation than has the size of the segment; nevertheless small segments usually pulsate slower than large ones.

In *Cassiopea xamachana* there are 13 to 23 marginal sense-organs, and I find that the average rate of the perfect Medusa is apt to be the same as the rate of its *most rapidly* working sense-organ. As Romanes saw in *Aurelia*, the sense-organs tend to initiate stimuli at various

rates, but the fastest controls all the others and forces them to beat in unison with it. To test this, I took a *Cassiopea* having 19 marginal sense-organs and a normal unexcited rate of 12 to 16 pulsations per minute. I then made 19 radial cuts midway between the 19 sense-organs, so as to divide the disk into 19 practically equal sectors, each enervated by a single sense-organ. These radial cuts through the sub-umbrella completely separated the sectors one from another in so far as the transmission of nervous impulses were concerned (fig. 3). Under these conditions one of the sectors pulsated 18 times per minute; 2 pulsated 17 times; 2 pulsated 16 times; 1 pulsated 15 times; 3 pulsated 9 times; 1 pulsated 8 times; 4 pulsated 7 times; 2 pulsated 6 times; 2 pulsated 5 times, and 1 failed to pulsate.

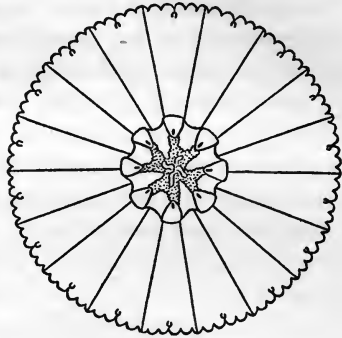

Fig. 3.

The sense-organs gradually change their rates, so that at the end of an hour or two the fastest may sink to second or third place, etc. Quite often one or more of the sense-organs either failed to send out pulsations or did so at very infrequent intervals. These sense-organs appeared normal, however, and if stimulated by being thrown into sea-water containing 1 per cent excess of K_2SO_4 they initiated pulsations at a rapid rate.

As Romanes and Eimer showed, if we cut off all but one of the marginal sense-organs this one will maintain a rhythmical pulsation of the disk, whereas if this last sense-organ be removed the disk at once becomes more or less paralyzed. The disks of *Aurelia* or of *Dactylometra*, however, begin to pulsate irregularly a few minutes after the loss of the last marginal sense-organ, but *Cassiopea* remains practically paralyzed for about 24 hours after the operation, rarely executing a pulsation unless stimulated. On the following day, however, it occasionally pulsates without apparent stimulation, and three days after the operation the disk rarely remains for a minute without pulsating. The pulsations are, however, isolated, single, and separated by irregular intervals of time, until the marginal sense-organs begin to regenerate.

Romanes showed that in *Hydromedusæ* the least discernible remnant of the bell-margin if left intact will maintain the rhythmical movement of the bell, but that in *Scyphomedusæ* the marginal sense-organs are the only parts of the rim which normally control the rhythmical pulsation. I find that if one cuts off the tip of the last remaining sense-organ of *Cassiopea*, thus removing the otoliths and

pigment spot but leaving the stalk of the sense-organ intact, the disk is instantly paralyzed. Also, when the marginal sense-organ regenerates, regular pulsation is resumed as soon as the pigment spot and a few small otoliths begin to appear. For example, figure 4 shows the appearance of the normal sense-organ, and figure 5 the condition of a regenerating sense-organ that has become capable of controlling the rhythm of the disk. Immediately after death the pigment of the sense-organ dissolves out into the sea-water; on the other hand it appears remarkably stable in the living animal, and is not faded by the most intense sunlight, nor changed by one month's confinement in absolute darkness.

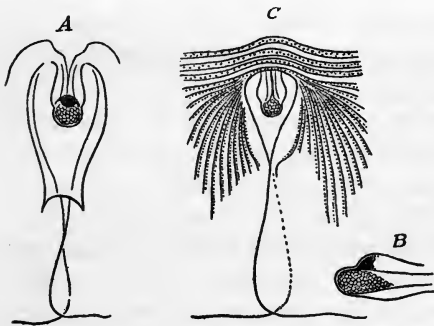

Fig. 4.

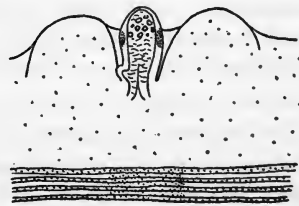

Fig. 5.

Fig. 4.—Enlarged views of a sense-organ of a mature *Medusa* of *Cassiopea*. A, aboral view; B, side view; C, oral view.

Fig. 5.—Enlarged oral view of a regenerating sense-organ, showing the beginning of the formation of pigment spot and otoliths. A wide strip of new tissue (dotted) separates the sense-organ from the old muscular layer of the sub-umbrella.

If a sense-organ be cut out with the merest remnant of sub-umbrella tissue left attached to it, examination under the microscope shows that this tissue continues to pulsate rhythmically, and it is apparent that the area of the sub-umbrella tissue attached to a sense-organ may be reduced to a practical zero without any more marked effect than a not very pronounced slowing of its rate of pulsation. On the other hand, if we remove all but one of the sense-organs and then place the disk in sea-water charged with CO_2 , keeping the sense-organ itself out of the fluid, the disk becomes paralyzed and can not be enervated into contraction by the sense-organ. In some of these experiments the sense-organ was also paralyzed, although it had not been in the CO_2 solution. In others the sense-organ continued to send contractions out over the adjacent tissue, but these could not extend over the parts of the sub-umbrella which were bathed by the CO_2 .

All experiments serve to demonstrate that the nervous relationship between the sense-organs and the general sub-umbrella tissue is reciprocal, as has been clearly shown by Romanes, who found that if we cut a strip of tissue from the disk of *Aurelia*, leaving a sense-organ at one end, and then gently stroke the end remote from the sense-organ with a camel's hair brush, the marginal sense-organ at the other end of the strip will be stimulated into sending a contraction wave back over the strip (Romanes, 1885, pp. 74-77). This discharge is therefore of a reflex nature. Nagel (1894) supports the idea that the marginal sense-organs are reflex centers, while von Uexküll (1901), upon evidence which to me appears insufficient, concludes that the marginal sense-organs in *Rhizostoma pulmo* are merely centers for the reception of mechanical stimuli, and that each pulsation of the bell causes the sense-organs to swing to and fro, and this stimulation calls forth a new pulsation.

We will show later that any point in the sub-umbrella surface may be made to start and maintain impulses which will set the whole disk into sustained and perfectly regular rhythmical pulsation. There is, therefore, no difference of kind between the nervous activities of the marginal sense-organs and those of any other parts of the sensory surface of the sub-umbrella.

As to the function of the otocysts in *Hydromedusæ*, Murbach (1903) showed that in *Gonionemus* they have no static function, for if they be removed the normal movements of the Medusa will be resumed before they are regenerated. Murbach's conclusion that the seat of the static function is "muscular sensation in the velum" requires confirmation. Injury of so important a swimming organ as the velum may readily cause irregularities in movements by abnormally deflecting the water currents passing through the opening of the velum at each contraction. Moreover, Yerkes (1902), in his study of the sensory reactions of *Gonionemus*, found that the velum is unaffected by stimuli of any sort.

Romanes (1885) found that the ocelli of *Sarsia* and *Tiaropsis* are sensitive to light, and Yerkes (1902) demonstrated that the tentacles of *Gonionemus* are very sensitive to chemical, mechanical, and photic stimuli.

The rates at which waves of contraction travel over the disk in *Cassiopea* range from 150 to 1200 mm. per second, each individual displaying a characteristic and constant rate. Apparently there is no relationship between the size of the Medusa and the rate of transmission of waves over its sub-umbrella tissue. These rates were

determined by cutting spiral strips reaching from the margin inward, in the manner of Romanes. It was observed that when the spiral was made 5 mm. or less in width only powerful stimuli would travel from one end of the strip to the other, and if under these conditions a single sense-organ was left at the outer end of the strip, waves of contraction which started from this sense-organ might or might not reach the central part of the disk. If, however, the end containing this sense-organ were touched with a crystal of K_2SO_4 , or any other potassium salt, a powerful wave of contraction immediately ensued and always traveled completely through the spiral. But if the inner end of the spiral were touched with the crystal of potassium salt, not only did the wave not always reach the sense-organ, but it traveled only three-quarters as fast as did the waves from the sense-organ. When the sense-organ was cut off, however, the waves traveled at the same rate from *either* end of the spiral strip, and this rate was the slower of the two mentioned above. Evidently the sense-organ reinforced the stimulus given by the potassium salt.

In this connection Romanes showed that in *Aurelia* strong stimuli may initiate waves that may travel over the disk at twice the rate of weak ones.

Peripheral parts of the disk transmit stimuli at a faster rate than do parts near the center of the disk. This was shown by Romanes to be the case in *Aurelia*. Altogether the outer parts of the sub-umbrella are more sensitive than the inner.

As Romanes showed, there must be an appreciable interval of rest between two successive responses to stimuli, and rhythmical waves can not follow one after another faster than a certain frequency. Waves traveling in opposite directions through the same strip of tissue meet and reinforce, but do not pass each other, for a stimulus can not produce a contraction over the tissue that has been in contraction only the instant before.

The sensory field of the Medusa is confined to the sub-umbrella and the mouth-arms. The ex-umbrella surface exhibits no reactions to stimuli, and indeed the epithelium of the ex-umbrella may be killed by such penetrating reagents as Gilson's fluid, and, provided the poisonous liquid does not reach the sub-umbrella, the rhythmical movement will not be altered in rate. Even near the margin of the disk, close to the sub-umbrella surface, the ex-umbrella is inert to stimuli of all sorts. The action of the sucker-like concavity at the aboral center of the ex-umbrella is entirely passive, and a Medusa deprived of all marginal sense-organs will still "cling" to the bottom or side of the aquarium, although paralyzed and motionless.

VITALITY, ETC.

The fluids of the central stomach of *Cassiopea* are practically neutral to litmus test, whereas the sea-water at Tortugas is decidedly alkaline. For example, litmus paper tinged pink by HCl is changed to blue in the sea-water in from 9 to 12 minutes, whereas a portion of the same litmus paper thrust into the central stomach cavity of *Cassiopea* will not become blue until it has remained in the stomach for 6 to 9 hours. The whole surface and all of the tissues of the Medusa are almost neutral and much less alkaline than is the sea-water. The stomach cavity may be filled with sea-water charged with CO₂, or we may place crystals of K₂SO₄ within it, and yet little or no effect will be produced upon the movements of the Medusa, although, as we shall see, these substances produce a profound effect if applied to the sub-umbrella surface. Remarkably little CO₂ is given off by the Medusæ in metabolism. A large Medusa was confined for 12 hours in a small quantity of sea-water tinged pink by rosolic acid, and the decoloration of the fluid was barely perceptible.

Cassiopea pulsates regularly and at its usual daylight rate throughout the night, and even red light has no apparent effect upon its rate of movement. If long confined in absolute darkness, however, the rate of pulsation becomes slower, and the plant cells within the tissues of the Medusa become shriveled and greatly reduced in number, so that the Medusa becomes pale blue in color and translucent. Only the filaments of the mouth-arms retain their greenish color. (Pl. II, fig. B.) The whole color of the Medusa becomes lighter and more uniform than the normal, as will be seen upon comparing figures A and B of plate II. Two Medusæ of *Cassiopea xamachana* were maintained in absolute darkness and without food for one month. When first placed in the dark their diameters were 82 and 42 mm., and their rates of pulsation 40 to 50 and 51 to 54 per minute, respectively. At the end of one month the large Medusa had shrunk so as to be but 58 mm. and the small one 25 mm. in diameter, and their rates of pulsation 23 and 17 per minute, respectively. On their being removed to the diffused daylight of the laboratory, the color remained unchanged for three weeks, but the diameters of the Medusæ continued to decrease; finally, however, the plant cells in the mid-region of the sub-umbrella and ex-umbrella became dark brown and densely crowded, so that these parts of the Medusæ were dull brown in color. After being in the light for one month the large Medusa was only 29 mm. in diameter, and its rate of pulsation was less than 1 per minute.

On the other hand, when the Medusa is maintained without food in the light it becomes dark brown in color (pl. II, fig. C), as will be seen upon comparing its photograph with that of a normally colored

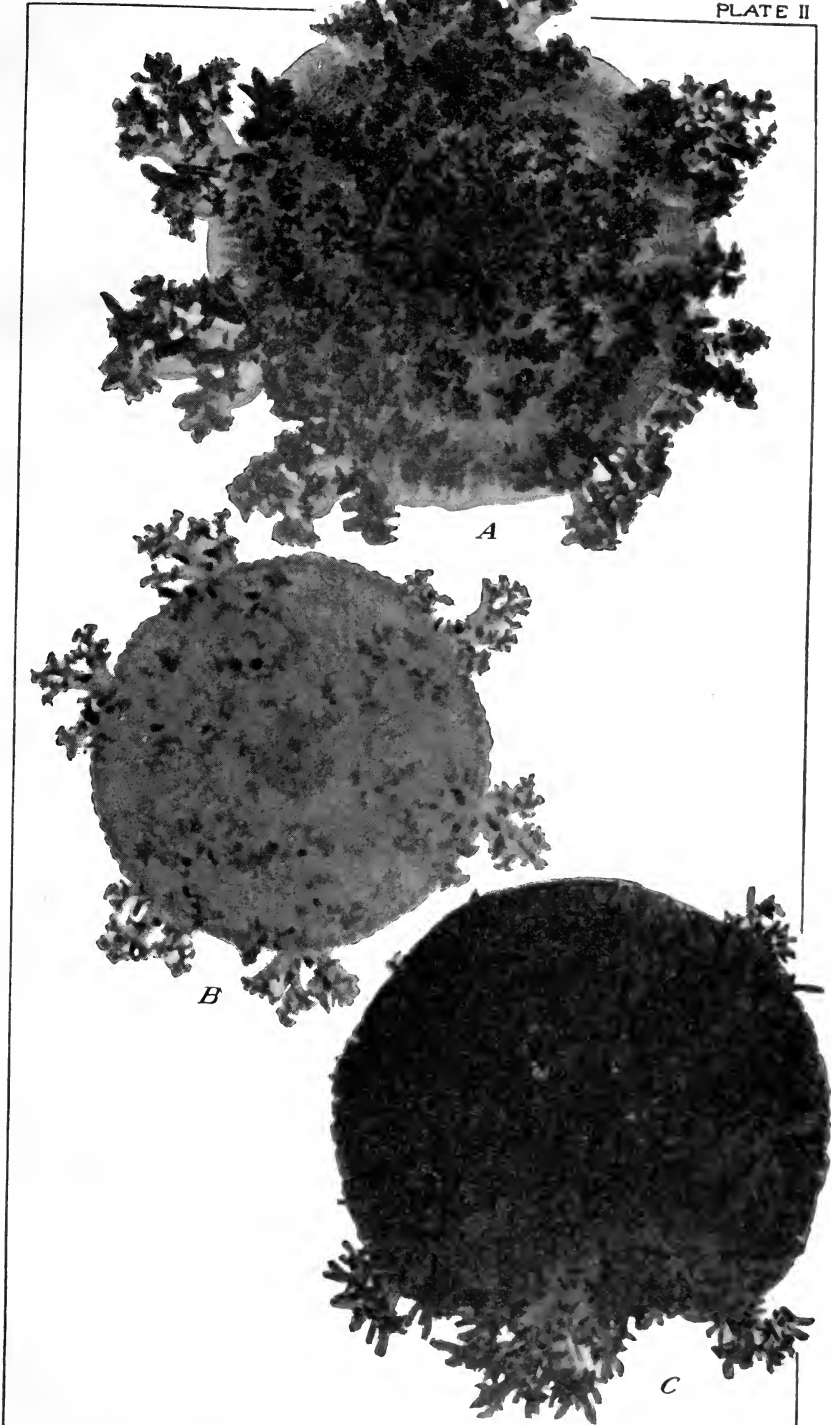

- A. Oral view of a normal, recently captured specimen of *Cassiopea xamachana*.
B. A specimen which has been maintained for one month in absolute darkness, showing its pale coloration. The plant cells are much reduced in number.
C. A specimen which has been starved for one month in the light, showing its very dark brown color.

Medusa. The greenish color of the oral filaments disappears, and the plant cells become shriveled and densely crowded. A Medusa starved in light is more active and shrinks more rapidly than does one starved in darkness, and thus it appears that metabolism proceeds more rapidly in light than in darkness. For example, a Medusa starved in diffused daylight had a diameter at the beginning of the experiment of 78 mm. At the end of 2 months its diameter was 37 mm., and at the end of 3 months, 21 mm., being still vigorous and pulsating at the rate of 16 per minute.

These starved Medusæ exhibited certain phenomena of degeneration. The mouth-arms became reduced to mere stumps, most of the mouths closed over, and the oral tentacles and filaments were absorbed or cast off, so that the oral surfaces of the mouth-arms became quite smooth and rounded. The marginal lappets of the disk became blunted, and the dull-white peripheral ring of the ex-umbrella was much reduced in width. Only immature eggs were found in the gonads of starving Medusæ. It appears remarkable that the first parts to degenerate are the mouths and mouth-arms, although these are the most important to the organism if in danger of starvation. The marginal sense-organs remained normal in size and appearance.

Cassiopea xamachana lives in salt-water lagoons having but limited communication with the sea, and it is therefore not surprising that it will survive considerable alterations of salinity. Fresh water (rain-water) is quickly fatal to the Medusæ, for they shrivel rapidly; all pulsations cease, and even if removed to salt water after less than five minutes' exposure to the fresh, recovery is very slow. On the other hand, if every night and morning we decrease the salt and increase the fresh water 5 per cent, the Medusæ can be brought into a mixture of 25 per cent sea-water plus 75 per cent fresh water, and still survive. Their rates of pulsation become successively slower as the salt water is reduced.

Thus, two Medusæ in pure sea-water had rates of pulsation of 20 and 60, respectively; in 60 per cent sea-water plus 40 per cent fresh water, 18 and 18, respectively; in 50 per cent sea-water plus 50 per cent fresh water, 14 and 18, respectively; in 40 per cent sea-water plus 60 per cent fresh water, 8 and 4, respectively; in 35 per cent sea-water plus 65 per cent fresh water, 7 and 2, respectively; in 30 per cent sea-water plus 70 per cent fresh water, 3 and 2, respectively; in 25 per cent sea-water plus 75 per cent fresh water, 3.

The small Medusa ceased to pulsate in 75 per cent fresh plus 25 per cent sea-water, and its sub-umbrella surface became insensitive to the most powerful stimuli, such as a touch of a crystal of KCl or K₂SO₄; yet when transferred to 50 per cent fresh plus 50 per cent sea water it

recovered and pulsated at the rate of 11 per minute. The large Medusa, which pulsated only 3 times per minute in 25 per cent sea-water plus 75 per cent fresh water, revived quickly and pulsated 18 times per minute in 50 per cent salt plus 50 per cent fresh water.

If instead of mixing the sea-water with distilled water, we employ a solution of fresh water containing the amounts of potassium and calcium found in the sea-water, the Medusæ do not survive as well as they would in ordinary brackish water, and their rates of pulsation are much slower, as will appear from the following: Three Medusæ in pure sea-water had rates of pulsation of about 60 per minute; the same Medusæ in 55 per cent sea-water plus 45 per cent rain-water containing the same amounts of potassium and calcium as sea-water, pulsated 8 to 14 times per minute; in 45 per cent sea-water plus 55 per cent rain-water containing the same amounts of potassium and calcium as sea-water, they pulsated 2 to 9 times per minute; in 40 per cent sea-water plus 60 per cent rain-water containing the same amounts of potassium and calcium as sea-water, they pulsated 1 to 6 times per minute; in 35 per cent sea-water plus 65 per cent rain-water containing the same amounts of potassium and calcium as sea-water, they pulsated 0 to 2 times per minute; in 25 per cent sea-water plus 75 per cent rain-water containing the same amounts of potassium and calcium as sea-water, two dead, one pulsated about once every 10 minutes.

Evidently a uniform reduction of the magnesium, sodium, potassium, and calcium is less injurious than a reduction of the sodium chloride and magnesium alone. As Ringer, Loeb, and others have shown, a *balance* in the *proportions* of the constituents of the sea-water is more important than the presence of any single salt.

As might be expected in Medusæ living in shallow lagoons, where evaporation is great, *Cassiopea* will withstand a considerable concentration of the salt water; however, Medusæ in 100 cc. sea-water plus 1 gram NaCl will survive for 12 hours, but their pulsation becomes irregular, although on the average of about normal rate. The mouth-arms, however, are strongly contracted, and the Medusa exhibits alternate periods of rest and activity in its rhythmical movements.

Cassiopea will pulsate normally in sea-water saturated with CaSO_4 .

As will be apparent from the above, *Cassiopea xamachana* is one of the hardiest of Scyphomedusæ. It survives for months in aquaria with but ordinary care, and exhibits wonderful recuperative powers from the effects of poisons. If subjected to constant shaking, as in a floating live-car, it does not thrive as well as in stationary aquaria where the water is not so pure.

THE NERVOUS OR EPITHELIAL NATURE OF THE STIMULUS WHICH PRODUCES CONTRACTIONS.

If the sub-umbrella be injured by scraping parts of it away, as in figure 5A, I, or if the margin be cut off as in figure 5A, III, the removed parts are soon partially regenerated, as shown in the dotted areas, but this newly regenerated tissue is at first epithelial in character, and lacks muscular elements. It therefore can not contract, yet if it be touched with a crystal of K_2SO_4 , or otherwise stimulated, it transmits the stimulus across itself to the adjacent muscular tissue of the sub-umbrella, which contracts vigorously, although the newly regenerated tissue which conducted the impulse does not itself contract. This

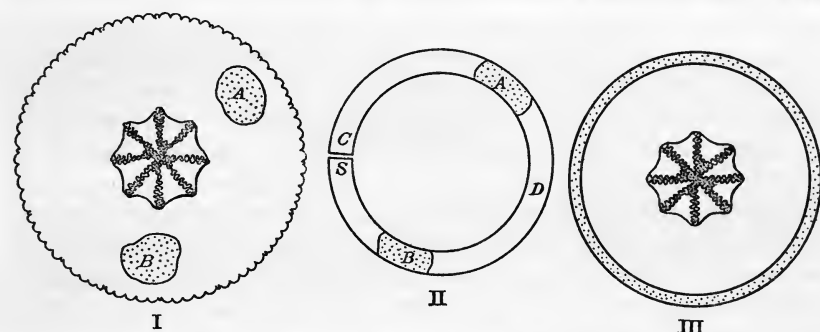
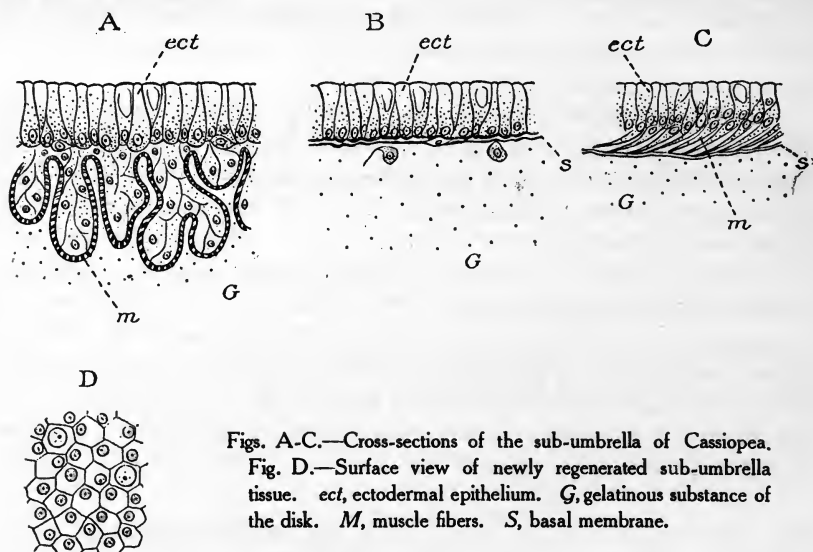

Fig. 5A.—Newly regenerated sub-umbrella tissue which lacks muscular elements, and can not itself contract, can still transmit the stimulus to pulsate to normal tissue adjacent to it. In fig. 5A, II, the stimulus crosses areas A and B, which do not contract, while C, D, and S contract in the order named. In fig. 5A, IV, the bridge of newly regenerated tissue does not itself contract, but serves nevertheless to transmit the stimulus causing contraction in E and F.

can best be demonstrated by making the newly regenerated tissue serve as a bridge connecting two pieces of uninjured sub-umbrella tissue, as is shown in figure 5A, II, or 5A, IV. Then, upon touching figure 5A, II, at S with a crystal of K_2SO_4 or other stimulant, a contraction wave passes from S through B-D-A-C; but B and A, being newly regenerated tissues without muscular elements, do not contract, although the stimulus which produces contraction passes across them. Similarly in figures 5A, IV, if E, which is normal sub-umbrella tissue, be caused to contract, every contraction is followed by F, although the bridge of newly regenerated tissue which connects them does not contract. These experiments tend to show that the stimulus which causes pulsation is transmitted by the epithelial or nervous elements to the muscular elements, and not primarily by the muscular elements themselves. I have examined many specimens of newly regenerated tissue

which did not itself contract, and yet transmitted the impulse which produced contraction in muscular tissue attached to it, and there appear to be no muscular elements in the newly regenerated tissue, although these often develop later. In these examinations I made use of intra vitem methylene blue, Retterer's method, Flemming's fluid followed by Ehrlick's acid hematoxylin, corrosive sublimate followed by aqueous carmine stain, and Hermann's fluid, but in no case could I find muscular elements in sections of the newly regenerated tissue which appeared to be a simple columnar epithelium, underlaid by a thin nervous net-work (see fig. 36). The muscle fibrillæ of the sub-umbrella are striate, and are easily demonstrated by any of the above methods.*



Figs. A-C.—Cross-sections of the sub-umbrella of *Cassiopea*.
 Fig. D.—Surface view of newly regenerated sub-umbrella tissue. *ect*, ectodermal epithelium. *G*, gelatinous substance of the disk. *M*, muscle fibers. *S*, basal membrane.

Figure A is a cross-section of the normal uninjured sub-umbrella of *Cassiopea*, cut across the trend of the circular muscle fibers; while figure B is a cross-section through regenerated sub-umbrella epithelium which has grown over an area from which all cellular elements had been cut away about 40 hours before. This newly regenerated tissue can not itself contract for, as yet, it lacks muscular elements; but it will nevertheless transmit the stimulus which produces contraction in

*Hesse (1895) finds that the nerve fibers in the sub-umbrella of *Rhizostoma pulmo* extend in all directions, but are mainly grouped in clusters extending from sense-organ to sense-organ. Bethe (1903) finds that in *Rhizostoma* and *Cotylorhiza* the epithelium of the sub-umbrella is connected with the deep-lying muscles by means of an intermediate plexus of nerve fibers.

muscular tissue adjacent to it. There are a few spindle-shaped (ganglion?) cells upon the basal membrane at the base of the regenerated epithelium, and occasionally one sees a large rounded cell in the gelatinous substance below the basal membrane. Occasionally these rounded cells have one or more delicate processes which extend into the gelatinous substance.

Figure C is a somewhat slanting section through regenerating sub-umbrella tissue about 4 days old, which is beginning to regenerate the muscle fibers and can now contract feebly. The muscle fibers appear as elongate processes of deep-lying epithelial cells, and extend parallel one with another over the basal membrane, trending circumferentially around the sub-umbrella.

Figure D is a surface view of newly regenerated sub-umbrella epithelium which transmits the pulsation-stimulus, but can not yet contract, as it still lacks muscular elements.

It is well known that Carlson has demonstrated the nervous nature of the stimulus which produces pulsation in the heart of *Limulus*. Indeed, I believe that all of the facts brought to light by Gaskell in his attempt to prove the muscular nature of the transmission of the stimulus of pulsation in the vertebrate heart will apply equally well if we assume that the impulse is transmitted by diffuse nervous elements. In the heart of the loggerhead turtle I find that the stimulus causing pulsation is transmitted entirely through the thin outer muscular part of the wall of the heart, and the thick cavernated inner part of the heart's wall may be cut away without affecting the pulsation. Also, the stimulus to pulsate is not transmitted through this cavernated tissue to the muscular tissue.

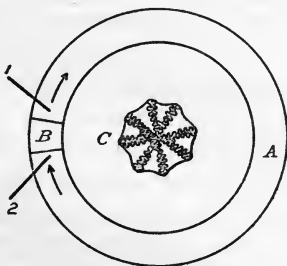

Fig. 5B.—Showing that the sub-umbrella tissue is a better electrical conductor than is the gelatinous substance of the bell. The current travels around through the long way, rather than across the shallow scratches which insulate the area B.

The sub-umbrella tissue of *Cassiopea* is a good conductor of electricity, while the gelatinous substance of the Medusa is a poor conductor. Thus in fig. 5 B, if we insulate an annulus by the shallowest possible scratch through the sub-umbrella, and then isolate a small sector, B, by shallow radial cuts; on touching the large sector A at 1 and 2

with the electrodes the contraction travels all the distance around *A*, but the sector *B* does not contract. The path of least electrical resistance is evidently through the long strip of sub-umbrella tissue, while the short path across the cuts interposes a greater resistance.

PULSATION WITHOUT MARGINAL SENSE-ORGANS.

Romanes, Eimer, von Uexküll, and others, have shown that in Scyphomedusæ the marginal sense-organs are centers which discharge the stimuli producing the rhythmical movements of the disk; and that if we remove these sense-organs, a more or less complete paralysis of the disk occurs. In some forms, such as *Aurelia* and *Dactylometra*, this paralysis lasts but a few minutes, and then more or less irregular contractions commence. In *Rhizostoma pulmo*, according to Hargitt, the paralysis is much more pronounced than in *Aurelia*. In *Cassiopea xamachana* the paralysis is practically complete for at least 24 hours, the disk responding only to definite stimuli, and very rarely giving a contraction without evident cause. On the second day after the operation the disk is much more sensitive to stimuli of all sorts and gives occasional isolated contractions without apparent stimulation, and at the end of a week the disk can rarely be observed for a minute without one's seeing it give a number of quick, isolated contractions. Regular rhythmical pulsation never sets in, however, unless the marginal sense-organs be regenerated.

Hitherto, disks without sense-organs have always been maintained in sustained pulsation by constant artificial stimulation, or by being placed in more or less injurious stimulating solutions. It will be recalled that Romanes obtained regular pulsation in the disks of *Aurelia* by passing through them a constant, or faradaic, current of electricity of minimal strength. He thus demonstrated that rhythmical movements might result from a constant stimulus, and he showed that one contraction could not follow another until the sub-umbrella tissue had recovered from the exhaustion caused by the previous contraction; then, and then only, can the tissue respond to the ever-present stimulus. Romanes concluded, therefore, that the ganglia of the marginal sense-organs may exert a constant stimulus, and yet give rise to periodic contractions. Romanes also found that the paralyzed bell of *Sarsia* could be set into a "flurried shivering" pulsation for one hour by a solution of 10 to 20 drops of acetic acid in 1000 cc. of sea-water, and that it would also respond by rhythmic contractions to a solution of 5 per cent glycerin in sea-water.

In 1900 Loeb found that the paralyzed disk of *Gonionemus* will pulsate rhythmically for an hour in a solution of $\frac{5}{8}$ n NaCl or $\frac{5}{8}$ n

NaBr, but that a small amount of calcium or potassium added to the Na solution will prevent the disk from pulsating. Loeb concluded that the calcium and potassium ions of the sea-water prevented the center of the bell of *Gonionemus* from pulsating. This is untrue for *Cassiopea*, for not only will the disk when deprived of sense-organs pulsate regularly for more than an hour in an artificial sea-water without calcium, but will also pulsate indefinitely in natural sea-water, and will contract rhythmically in solutions containing NaCl + KCl, or NaCl + CaCl₂, or NaCl + KCl + CaCl₂ in amounts and proportions found in sea-water. All solutions containing *magnesium* tend to prevent pulsation in the disk of *Cassiopea*.

As a result of his work upon the skeletal muscles in 1899 Loeb concludes that rhythmical contractions occur only in solutions of electrolytes, *i. e.*, in compounds capable of ionization, and that in solutions of non-conductors such as glycerin these rhythmical contractions are impossible. However, Romanes found that glycerin caused rhythmical pulsation in *Sarsia*. Greene (1898) and Howell (1901, p. 189) found that strips of heart muscle, after having ceased to pulsate in NaCl, will again pulsate if immersed in a pure solution of cane sugar or dextrose isotonic with the NaCl solution, and I find that the heart of *Salpa* will pulsate normally for more than half-an-hour in dextrose, isotonic with sea-water (see table 6). Thus automatic beats may occur in a solution entirely free from electrolytes, but, as Howell shows, these beats are probably dependent upon the presence of electrolytes in the tissue itself.

When we come to consider the effect of ions, etc., upon *Cassiopea*, it will appear that one must be cautious of drawing general conclusions, even from the most evident effects upon any one animal. Thus I find that chemicals which produce certain perfectly definite and invariable responses upon *Cassiopea* act differently upon *Aurelia*, *Dactylometra*,

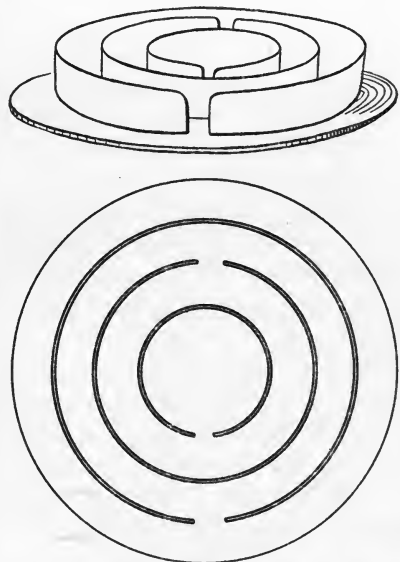

Fig. 6.—A disk of *Cassiopea* pressed by a concentric series of block-tin rings so as to insulate circuits of tissue. A disk so pressed may be caused to pulsate continuously.

Gonionemus, *Lepas*, *Salpa*, and the loggerhead turtle. If there be marked differences between the reactions of closely related Scyphomedusæ, one may expect even greater disparity between those of vertebrates as compared with invertebrates.

Romanes, Loeb, von Uexküll, Hargitt, and others have caused disks to pulsate temporarily by subjecting them to the influence of NaCl solutions, etc., but in all cases more or less toxic effects resulted from the experiments and the sensibility of the sub-umbrella tissues became impaired or destroyed, so that further stimulation soon became impossible. We will now describe a method by which the disk of *Cassiopea* when deprived of marginal sense-organs may be made to pulsate indefinitely in sea-water with the production of effects no more injurious than those of fatigue. This may be most readily accom-

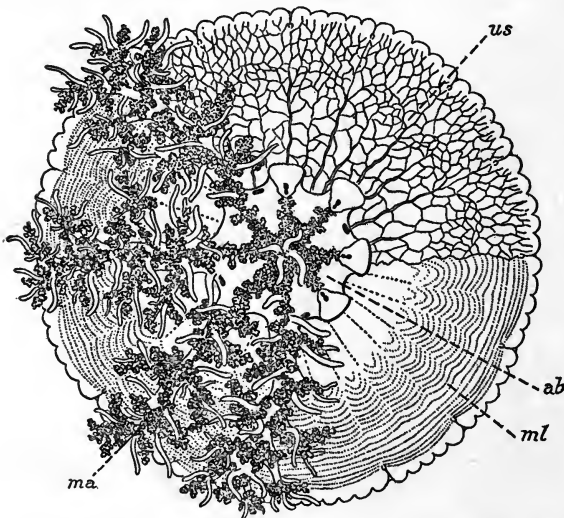

Fig. 7.—Oral view of *Cassiopea xamachana*. Four of the mouth-arms are cut off, and the muscle layer of the sub-umbrella in the upper right-hand quadrant removed to show the underlying vascular system. *ab*, Mouth-arm plate; *ma*, mouth-arm; *ml*, muscular system of the sub-umbrella; *us*, vascular canals of the sub-umbrella.

plished by cutting off all marginal sense-organs, and then making a series of concentric, discontinuous, ring-like cuts through the muscular tissue of the sub-umbrella, as is shown in figures 8 to 19.* Then upon stimulating the disk in any manner it instantly springs into rapid rhythmic pulsation, so regular and ceaseless as to remind one of the movement of clockwork. The cuts must be so made as to permit a free passage of contraction waves through sub-umbrella tissue forming a closed circuit. The simplest circuit is, of course, a single ring

* A glance at figure 7 will show that the muscular area of the sub-umbrella is a wide annulus with the mouth-arm disk and stomach in the center. In figures 8 to 33 we have represented the disk as a circle, the small concentric circle at the center being the mouth-arm disk, while the wide annulus is the sub-umbrella.

(annulus) of sub-umbrella tissue; and such a ring can readily be set into sustained pulsation.

It is not necessary, however, that cuts be made through the sub-umbrella tissue; for mere pressure prevents the transmission of contraction waves across the pressed region, and we may form circuits by pressing lightly upon the sub-umbrella with a concentric series of metallic rings, as is shown in figure 6. Then upon stimulating the disk in any manner it pulsates rhythmically.

Disks which have been cut, or pressed, as described above do not pulsate until they have been momentarily stimulated at some definite

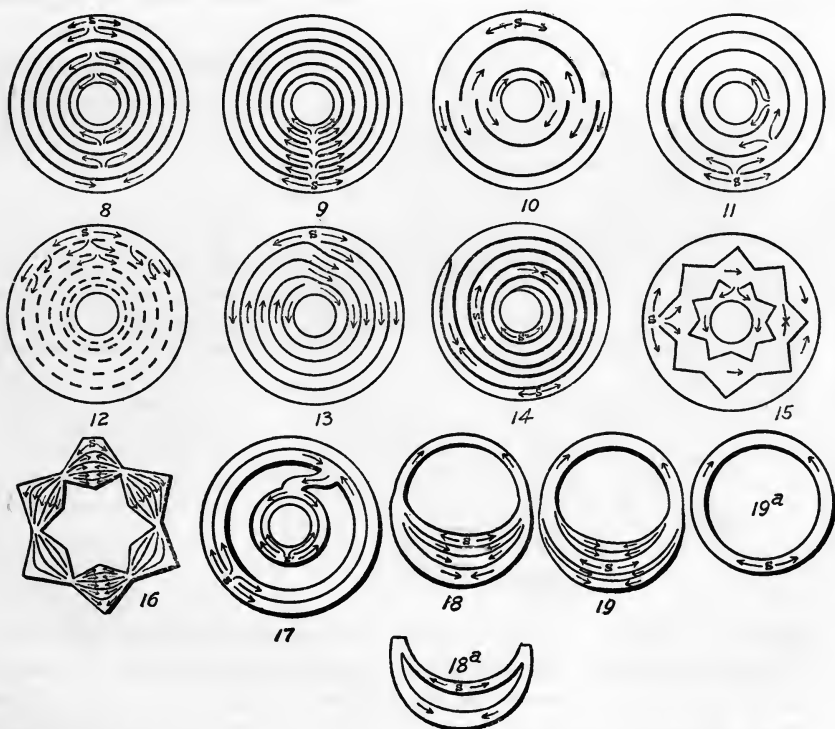

Figs. 8-19a,—Shapes cut from disks without marginal sense-organs. These will pulsate continuously in sea-water.

point by a touch of some potassium or sodium salt, a mechanical or electrical shock, or by suddenly cutting off the last remaining sense-organ immediately after it has sent out its contraction wave.

A contraction wave travels outward from the stimulated place through the circuit of sub-umbrella tissue, and when it returns to the point whence it started it is immediately reinforced, and again sent

through the circuit. Thus there is normally but one contraction wave which proceeds from its center, travels through the labyrinth of sub-umbrella tissue, and returns to the center whence it came, only to be again augmented and sent forth.

It is thus the function of the center to reinforce and maintain the contraction wave. This is well shown in a long circuit such as is shown in figure 30, I-III; where on account of the great length of the circuit the course of the wave may readily be followed by the eye. The outer annuli of the sub-umbrella tissue are more sensitive, and conduct contraction waves* better than do the inner parts of the disk;

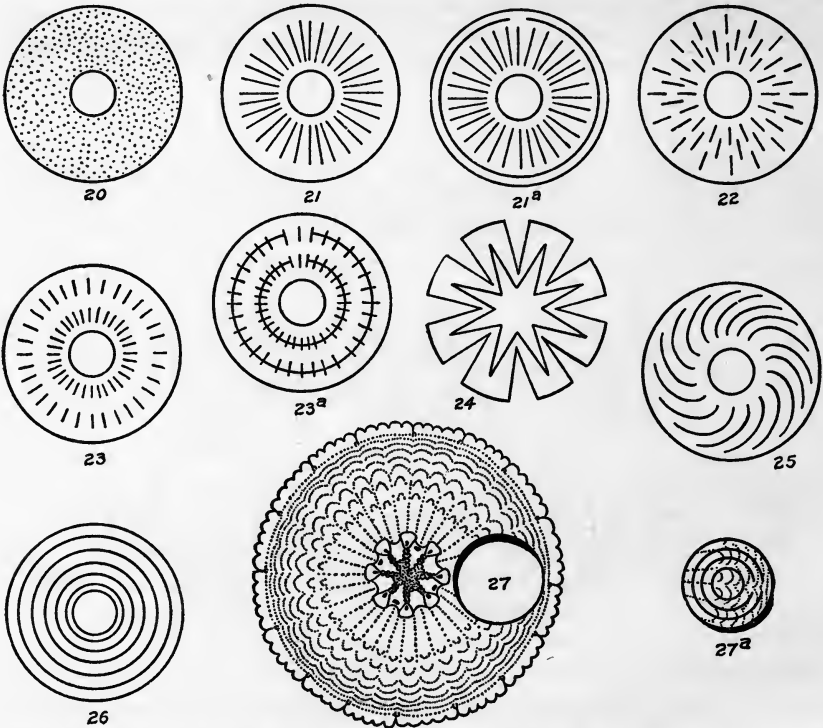

Figs. 20, 21, 22, 23, 25, 27a, disks cut so that they can not be set into continuous pulsation.

Figs. 21a, 23a, 24, 26 can be set into sustained pulsation in sea-water.

and if we touch the disk at *A*, figure 30, I, the greater part of the contraction wave takes the short path of *least resistance* into the interior of the labyrinth, as is shown by the full arrow, and only a very weak wave goes in the direction of the dotted arrow. The strong contraction

* The sub-umbrella tissue is a good conductor of electricity, but the gelatinous substance of the Medusa is a poor conductor.

wave then proceeds as is shown by the sequence of arrows and numbers until it finally returns with lowered amplitude to the center, where it is instantly restimulated and again sent through the circuit with its energy restored. The same conditions apply to figures 31, II and III.

When in regular pulsation we always find that the waves of contraction start from a definite place. The position of this center tends to bear a certain relation to the geometrical figure formed by the cuts. It is marked *S* in figs. 8 to 19*a*, and the arrows show the observed courses of the wave of pulsation. Usually the center of pulsation lies near the periphery of the disk at a place where the tissue is widest and least interfered with by cuts, and it also tends to lie upon the axis of bilaterality of the labyrinth of tissue.

If we stimulate the disk by dropping it upon a glass plate, etc., the waves of pulsation start from the point *S*; and this is the place where we must touch the disk if we wish to stimulate it into sustained pulsation. *Wherever* we touch the disk with a crystal of K_2SO_4 , waves of contraction immediately start out from the touched point, but it is usually impossible to establish a permanent center of

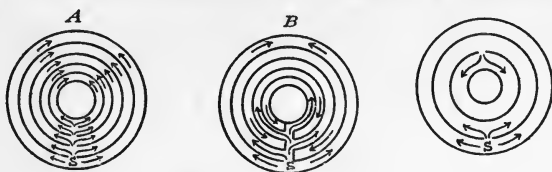

Fig. 28.

Fig. 29.

pulsation at any point other than one upon the geometrical axis of the figure. Centers at other places either cease to initiate pulsations when the effect of the initial stimulus dies out, or the center quickly shifts to the geometrical axis. Sometimes, however, when a disk is stimulated by a severe mechanical shock, two or more permanent centers of pulsation appear and waves of contraction start out from each independently and interfere where the opposing waves meet one another. Such conditions are shown in figures 14 and 17.

It will be observed that with the exception of the very elongate spiral (fig. 14) all of the labyrinths formed by the cuts are *closed circuits*, the tissue being merely a more or less complicated circuit, with the center of pulsation at the geometrical center of the figure. *After* the disk has begun to pulsate we may cut away portions of the labyrinth, and the part containing the center will still pulsate, *provided* it remains a closed circuit. Thus the crescent (figure 18*a*) is cut out from figure 18 and the ring (figure 19*a*) is made from figure 19,

by cutting them out after the more complicated circuits had been set into pulsation. Instead of simplifying the pulsating labyrinth, we may increase its complexity, but as long as the waves proceeding from the center can find a single uninterrupted circuit, the figure pulsates. Thus, a disk cut as in figure 28, A, is set into pulsation and then all of the inner rings are cut so as to be converted into "cut-off" paths as in figure 28, B; but the disk continues to pulsate until we cut across the outermost ring, when it stops instantly. Every one of the forms shown in figures 8 to 19a can be thus stopped by even the smallest cut which breaks the last circuit, although they continue to pulsate despite any cutting which does not sever the circuit. Thus, figure 16 stops at once if we cut across one of the narrow places between the rays of the star.

The center of pulsation usually establishes itself in a large uncut area, but once it be established we may greatly cut down this area and not interfere with the center. Thus, the ring shown in figure 19a may be thinned by cutting at *S*, but the center remains undisturbed.

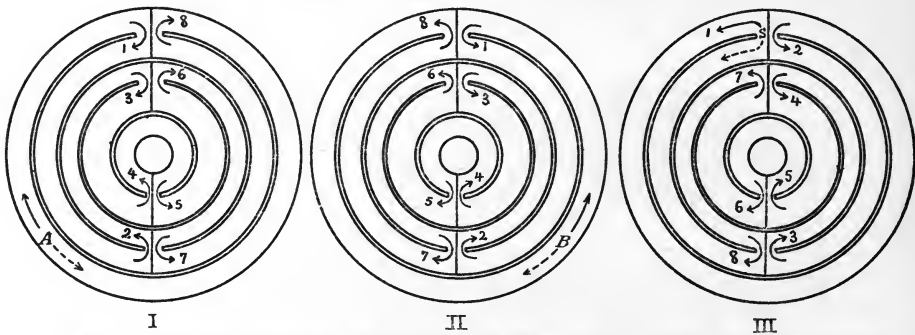

Fig. 30.—Very elongate circuits showing that the peripheral parts are better conductors of pulsation than are the inner parts of the sub-umbrella. These circuits can be caused to pulsate continuously.

Sustained pulsation without marginal sense-organs can be maintained only in tissue forming a closed circuit. These circuits may be complex and constricted at intervals to mere thread-like connectives, as in figures 31, A-C, where every annulus is crossed by radial cuts; or they may be very simple, as in figure 31, D. The circuits may either cross or trend with the muscle fibers.*

On two occasions disks were set into sustained pulsation when only the marginal sense-organs were cut away; no other cuts having been

*The statement in my preliminary paper in the Carnegie Institution Year Book for 1905 that the circuits must trend with the muscle fibers is erroneous.

made. This can rarely be accomplished, however, for the returning wave must usually be focused back upon the center in order to be sustained; and in a wide annulus it is dissipated and returns with too little force to call forth the latent ability of the center to restimulate the wave. Similarly figures 20, 21, 22, 23, and 25 represent forms which dissipate and confuse the contraction wave, setting up "eddy currents" which weaken the wave and prevent its returning definitely

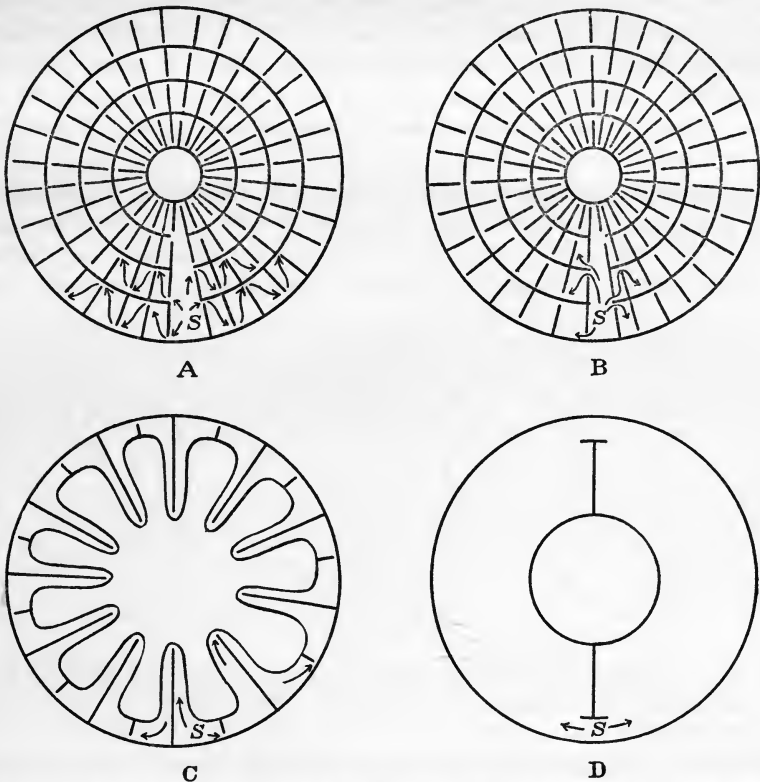

Fig. 31.—A, B, and C, disks having every annulus crossed by radial cuts, but which may be set into sustained pulsation. D, a simple circuit which may be set into sustained pulsation.

and forcefully to the center. Hence these figures can not be set into sustained pulsation. If, however, we cut partial rings, as in figures 21a and 23a, or convert figure 21 into a shape such as is shown in figure 24, we find no difficulty in setting them into sustained pulsation. In all of these cases the figures oblige the contraction wave to return definitely and forcefully to the center. I could not obtain sustained pulsation in a disk cut out of the side of a Medusa as in figures

27, 27a. This, I believe, is due to the fact that the contraction wave returns so quickly to the center that an insufficient time elapses before the center is again called upon to restimulate the wave. As Romanes showed, an appreciable interval of time must elapse before tissue which has been in contraction can again contract.

Very elongate, many-whorled spirals, such as one sees in figure 14, are the only forms *not* closed circuits that we have succeeded in setting into constant pulsation. This occurs only when two or more centers arise simultaneously in the spiral, as in *S*, *S'*, and *S''*, figure 14. These centers mutually sustain one another, the contraction wave from one being restimulated and reflected back from the other. If one attempts to convert a series of partial rings (fig. 32, A) into a spiral by successive cuts, as shown in the dotted lines, 1-5, (fig. 32, B) the tissue ceases to pulsate as soon as the final cut (5) is made which breaks the last circuit.

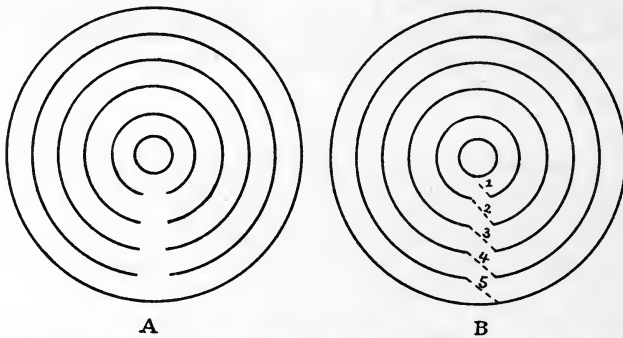

Fig. 32.—Showing that sub-umbrella tissue can not maintain itself in pulsation unless it has the shape of a closed circuit. If cuts be made as shown in the dotted lines in the order 1, 2, 3, 4, 5, the tissue ceases to pulsate as soon as cut number 5 breaks the last complete circuit.

It must be borne in mind that cuts through the sub-umbrella tissue heal over in the course of a day or two and will then transmit pulsation more or less imperfectly across the healed lines, and then a spiral will pulsate, for it is, physiologically speaking, only a series of concentric rings of readily conducting tissue with numerous more or less imperfect points of conduction between the annuli. Similarly a disk having *complete* circular cuts through the muscular tissue of the sub-umbrella, such as is shown in figure 26, can not be made to pulsate continuously as a whole until two or three days after the operation, although each annulus may be made to pulsate independently. After several days of healing the cuts will allow a more or less imperfect conduction of impulses across from one ring to another, and the con-

traction waves will be unimpeded circumferentially, but more or less hindered radially. That this is the true explanation of the matter is proven by the fact that the disk shown in figure 12, wherein the circumferential cuts are numerous and the spaces between are as wide as the cuts are long, will pulsate continuously.

Mere mutilation of a disk without sense-organs will not cause it to become capable of continuous pulsation. Thus the disk shown in figure 20, having about 800 punctures made through its sub-umbrella tissue, can not be set into a sustained rhythm.

Although I had several hundred paralyzed disks of *Cassiopea* capable of being set into pulsation by a stimulus, such as a momentary touch of a crystal of K_2SO_4 , only one of these started into pulsation of its "own accord." Ordinarily they might remain for days in the aquaria awaiting the momentary stimulus which alone could call forth their latent power of rhythmical pulsation.

If disks without marginal sense-organs be set into rhythmical pulsation they move with machine-like regularity, without pauses, and without any of the irregularities shown by normal *Medusæ* with sense-organs intact. Their rates of pulsation are not only practically uniform, but they are much faster than are those of the uninjured normal *Medusæ* from which the disks were prepared, as will be shown by the following table :

TABLE 2.—Rate at which normal *Medusæ* of *Cassiopea* pulsed and the rates of pulsation of their disks when the sense-organs were excised and circumferential cuts were made in the sub-umbrella.

Rate of pulsation of the normal <i>Medusa</i> before operation.	Rate of pulsation of disk without sense-organs.	Figure showing the form of the cuts made in the disk.
25-30	77-88	8
32	63-78	9
40	183	12
51	85	13
15-20	{ Outermost center S . . . 117	} 14
	{ Mid-region center S' . . . 101	
	{ Innermost center S'' . . . 78	
47	{ Outermost center . . . 80-82	} 17
	{ Inner center 66-68	

When disks without sense-organs are set into pulsation we may reduce the area of pulsating tissue by cutting parts of it away, but the rate of pulsation will remain constant, provided we do not alter the *length* of the circuit through which the wave must pass. If, however, we make cuts in such manner as to increase the length of the circuit

the rate of pulsation becomes slower. For example, twenty disks were cut as shown in figure 33, A, and after they had been set into pulsation they were cut across as shown in figure 33, B. This cut made the circuit twice as long as it was formerly, and obliged the contraction wave to travel double the distance in order to traverse the circuit.

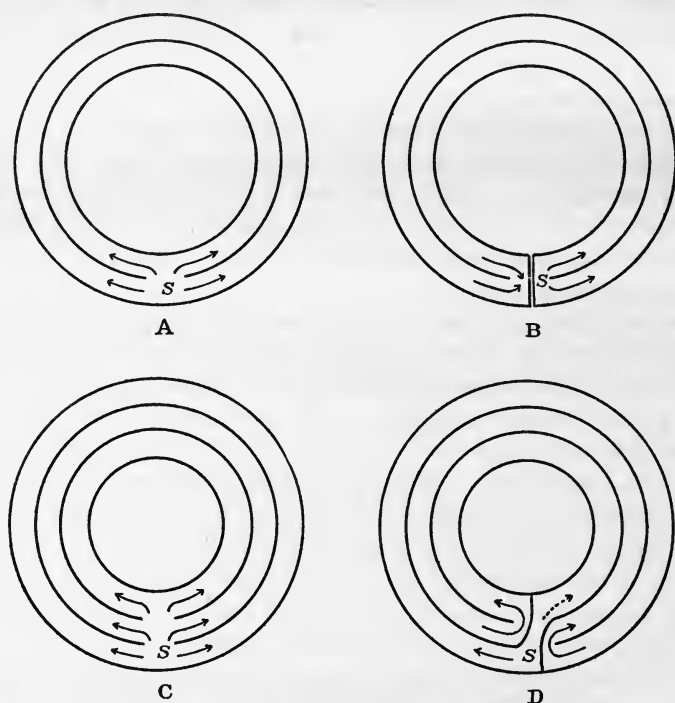

Fig. 33.—Showing how cuts may be made so as to increase the length of the pulsating circuit, thereby decreasing its rate of pulsation.

We might then expect the pulsation to be reduced to one-half its former rate, but as a matter of fact the wave traveled on an average 1.16 times as fast in the long as it did in the short circuit, so that the cut reduced the rate to but 58 per cent of its former value.

Similarly, if we set disks cut as shown in figure 33, C, into pulsation, and then make two cuts as shown in figure 33, D, making the circuit almost three times as long as it was before, the rate becomes about 0.4 of its former value, not 0.33 as we would expect. I believe that the faster rate of the contraction wave in the long circuit is due to the longer rest which the tissue enjoys, thus allowing it the more completely to recover and regain its sensibility to the stimulus which calls forth the contraction. Romanes showed that strong contraction

waves travel faster than weak ones, and that strong stimuli repeated at short intervals soon tired the tissue, so that it failed to respond.

The rate of pulsation of disks is greater than their most excited rate when the sense-organs are intact; in other words, the disk itself can maintain pulsation at a faster rate than can the marginal sense-organs. The rate of pulsation in the disks deprived of sense-organs depends simply upon the time required for the waves to traverse the circuit and restimulate the center. The wave travels faster through peripheral than through the inner annuli of the disk. When pulsating disks are suddenly seized, moved, or otherwise stimulated, the *amplitude* of their rhythmical movement suddenly increases, but the *rate* remains practically the same, and thus the presence of the marginal sense-organs is not necessary for the display of excitement. The disks of small Medusæ pulsate at a faster rate than do those of large ones, other things being equal.

These pulsating disks may continue to give regular rhythmical contractions in sea-water for 140 hours or more, but at the end of that time, if they have been deprived of their mouth-arms and central stomach, they become exhausted, and the *amplitude* of their pulsation decreases, although the *rate* remains practically constant. Suddenly the center fails to restimulate the returning wave, all movement ceases, and the disk can not be re-stimulated until after a period of rest. Indeed, the tissue appears much exhausted and responds feebly even to the strongest stimuli, such as K_2SO_4 , KCl , etc. Complete recovery takes place, however, in normal sea-water, so that disks may be maintained in condition to pulsate for weeks.

While in sea-water it is almost impossible to set a Medusa, with marginal sense-organs intact, into any form of pulsation other than that controlled by the sense-organs. If, however, we cut partial rings in the sub-umbrella of a *Cassiopea*, leaving the sense-organs and margin intact, and then place the Medusa in a solution resembling sea-water but *lacking* calcium,* all pulsations will cease in from 2 to 6 minutes. Then, after the Medusa has remained motionless in the solution for one hour, if we touch the disk for an instant with a crystal of K_2SO_4 it immediately springs into a rapid rhythmical pulsation at a much faster rate than that previously maintained by the sense-organs. This pulsation, indeed, exhibits all of the features shown by disks *without* sense-organs, and therefore we see that the absence of calcium has

*965 H_2O + 26.74 $NaCl$ + 3.75 $MgCl_2$ + 1.64 $MgSO_4$ + 0.85 K_2SO_4 + 0.07 $MgBr$, or Van 't Hoff's solution consisting of 100 $NaCl$ + 2.2 KCl + 7.8 $MgCl_2$ + 3.8 $MgSO_4$, all of $\frac{1}{10}$ n concentration.

caused a paralysis of the *marginal sense-organs*, but *not* of the sub-umbrella tissue of the *disk*.

This we can prove directly, for disks without sense-organs, once they be set into pulsation, will continue to pulsate for *over three hours* in a solution resembling sea-water but lacking calcium. The amplitude of their pulsations, however, decreases steadily, but may be *restored* by adding calcium to the solution. It is evident that the central parts of the sub-umbrella of *Cassiopea* may pulsate both in normal sea-water, and for a long time in sea-water deprived of calcium, whereas the marginal sense-organs are quickly paralyzed by a deficiency of calcium in the sea-water. On the other hand, perfect Medusæ and disks deprived of sense-organs will pulsate in sea-water at 82° F. containing $\text{CaSO}_4 + \text{CaCO}_3$ to saturation, the only effect being a slight slowing of the rate of pulsation in the case of the perfect Medusæ. Hence the marginal sense-organs require calcium* to perform their function, whereas the general tissue of the sub-umbrella is relatively unaffected by the presence or absence of calcium. This is, however, a *relative* matter, for while the lack of calcium produces less effect upon the disk than upon the sense-organs, nevertheless the disk itself will *finally* cease to pulsate in the absence of calcium. It is interesting to observe that while the disk is almost unaffected by a wide range in the amount of calcium in the sea-water, it is very quickly affected by a change in the amount of the potassium. Such disks cease to pulsate in a few minutes either in a solution resembling sea-water but *lacking* potassium or in a solution of $\frac{1}{4}$ gram K_2SO_4 in 100 c.c. of natural sea-water. Indeed, the center of the disk is fully as sensitive to changes in the amount of potassium in the water as is the entire Medusa.

Under normal conditions pulsation is controlled by the marginal sense-organs, the rate being that of the fastest working sense-organ. The general sub-umbrella surface has considerable influence in sustaining the sense-organs, for if we reduce the area of the sub-umbrella enervated by the sense-organs the rate declines. Normally the pulsation is controlled by the sense-organs, not by centers of pulsation in the undifferentiated sub-umbrella tissue. Among thousands of normal Medusæ I observed only two individuals in which a center in the sub-umbrella controlled the pulsation. These two were pulsating slowly when I lifted them out of water and threw them forcibly back. They instantly began to pulsate in the rapid, uniform, clockwork-like manner characteristic of pulsation maintained by a center in the sub-umbrella, their rates being fully four times as great as the normal. I then cut off their marginal sense-organs, and the disks still continued

* The chief rôle of calcium is to counteract the anæsthetic effects of magnesium.

to pulsate without alteration in their rates. They both ceased instantly as soon as a radial cut was completed from center to margin, thus breaking the circuit of the waves of contraction.

We have seen that a center of pulsation in the undifferentiated sub-umbrella tissue sends out its stimulus only when the contraction wave returns to it through the circuit, and that therefore the rate must be constant, for it depends only upon the length of the circuit and the rapidity of the wave; and no pulsation can be maintained by a center in the sub-umbrella tissue unless the contraction wave can pass through a circuit and finally travel back to restimulate the center.

The marginal sense-organs behave differently. They send forth the stimulus, which produces contraction, at a slow, irregular rate, and they are not restimulated into immediate action by a returning wave, and can maintain tissue in pulsation even if its shape is not that of a closed circuit. They function only when calcium is present in solution in the sea-water, and if lifted out of water and dried with blotting paper they cease in a few minutes to initiate pulsations; but if then they be moistened with distilled water containing the amount of calcium found in sea-water, they recommence pulsation. Indeed, the sense-organs behave as if a slow chemical change takes place within them, the result being a contraction-stimulus; and this state of contraction in turn reducing the built-up compounds to their original condition. Calcium has the peculiar power to offset the stupefying influence of the *magnesium* of the sea-water, but calcium is of primary importance only when magnesium is present. If magnesium be absent the presence of calcium is relatively unimportant in the pulsation of *Cassiopea*. Indeed, the Medusa pulsates longer and faster in a solution containing the amounts and proportions of NaCl + KCl, found in sea-water than it does in NaCl + CaCl₂.

Before closing the account of these experiments upon disks it should be stated that the disks of *Aurelia flavidula* and *Dactylometra quinquecirra* may also be set into sustained and regular rhythm by cutting partial rings, as has been described in the case of *Cassiopea*. These Scyphomedusæ, however, soon recover to some extent from the loss of their marginal sense-organs, and the chief difference between their usual behavior after the loss of the margin and their behavior when cut by partial rings and then set into pulsation is that in the latter case the pulsation is of machine-like regularity and without pauses, whereas under normal conditions it is irregular. *Dactylometra* is more favorable for these experiments than *Aurelia*, for *Aurelia* is extremely sensitive to mechanical shocks and to chemical stimuli. It is of interest to observe that the rate at which the tissues of the disk of

Dactylometra maintain these pulsations is only a little higher than that maintained by its marginal sense-organs. For example, a *Dactylometra* which pulsed 39 times per minute when intact pulsed 46 times per minute with perfect regularity when all sense-organs were removed and partial rings were cut in its sub-umbrella.

It will be recalled that Romanes briefly mentions a specimen of the hydromedusa *Staurophora laciniata*, in which there were three centers of spontaneous contractions after the bell margin was removed. I have not succeeded in causing the disk of *Gonionemus* to pulsate continuously by cutting partial rings in its sub-umbrella after the margin had been removed. There were, however, but a few small specimens at my disposal. As Yerkes found, the central disk of *Gonionemus*, when deprived of its margin, often gives isolated contractions without external stimulation.

III. REACTIONS OF CASSIOPEA TO CHEMICAL STIMULI.

CHEMICAL STIMULATION OF PARALYZED DISKS.

As we have seen, the loss of the marginal sense-organs paralyzes the disk of *Cassiopea*, but it still reacts strongly by contractions if the surface of its sub-umbrella be touched by certain substances, while others have no effect upon it.

Strong solutions or crystals of the following produce contractions: $KAl(SO_4)_2$, KBr , KCN , K_2CO_3 , KCl , $KClO_3$, K_2CrO_4 , $K_2Cr_2O_7$, $K_8Fe_2C_{12}N_{12}6H_2O$, KI , $KMnO_4$, KNO_3 , KOH , $KHSO_4$, K_2SO_4 , $K_2S_2O_7$; also Na_2CO_3 , $NaHCO_3$, $NaCl$, $NaClO_3$, $Na_2HPO_4 \cdot 12H_2O$, NaN_3 , $NaOH$, $NaSO_3 \cdot 7H_2O$, $Na_2SO_4 \cdot 10H_2O$, and sodium oxalate; also $LiCl$, $BaCl_2 \cdot 2H_2O$, $BaSO_4$, $Ba(OH)_2$, NH_4OH , glycerin, dextrose, $CuSO_4$, Fe_2Cl_6 , $PtCl_2$, and iodine, etc. Contractions are also produced by very weak solutions of the following acids: Acetic, chromic, oxalic, sulphuric, hydrochloric, picric, nitric, and formic. This effect is doubtless due to hydrogen, the only element common to all of these acids.

The following substances produce no contractions, even when the crystals themselves, or their saturated solutions, are applied to the surface of the sub-umbrella: $MgBr$, $MgCl_2$, $MgCO_3$, $MgSO_4$; also $CaCO_3$, $CaCl_2$, CaO , $CaSO_4$, and $SrCO_3$, $SrCl_2 \cdot 6H_2O$, $SrSO_4$, $HgCl_2$, $FeSO_4 \cdot 7H_2O$, CH_4N_2O .

Summarizing the above, we see that all salts of potassium, sodium, lithium, barium, and platinum produce contractions, as do also weak solutions of acids, glycerin, dextrose, ammonia, and iodine. By far the strongest contractions are produced by potassium salts, while sodium salts produce much weaker effects. Nevertheless the $NaCl$ of sea-water is a more powerful stimulant than the potassium (K_2SO_4

or KCl), owing to its far greater amount. The salts of calcium, magnesium, and strontium do not stimulate the disk and fail to produce contractions, even when in saturated solutions.

Combinations of Mg or Ca with Na or K may or may not give contractions, for the Mg always, and Ca in some cases,* tends to inhibit pulsation. Thus a series of contractions are produced by $5K_2SO_4 \cdot Na_2SO_4$, $Na_2SO_4 \cdot 3K_2SO_4$, $MgCl_2 \cdot 2KCl \cdot 6H_2O$, $K_2Mg(SO_4)_2$, $Na_2Mg(SO_4)_2 \cdot 4H_2O$, $K_2Ca(SO_4)_2 \cdot 2H_2O \cdot MgSO_4$, $MgCl_2 \cdot K_2SO_4 \cdot 6H_2O$, and $MgCl_2 \cdot NaCl \cdot 2H_2O$; the first named giving powerful and the last weak contractions. On the other hand, $Ca_2K_2Mg(SO_4)_2$ and $CaCl_2 \cdot 2MgCl_2 \cdot 12H_2O$ give no contractions. The salts act in accordance with their mass-effects. It is interesting that solutions of the ashes of the Medusa will not produce contractions, although Merunowicz (1875) found that an aqueous solution of the ashes of the blood will stimulate the vertebrate heart into action.

Loeb (1905) states that Ba, Li, Na, Rb, Cs, F, Cl, Br, and I are capable of bringing about contractions in skeletal muscles; whereas K, Mg, Ca, Sr, Mn, and Co give rise to no contractions or inhibit them.

It is evident that the stimulating effects of the electrolytes are generally due to their cations rather than to their anions, but contractions may also be produced by substances which can not be ionized, such as glycerin and dextrose, and weak contractions are sometimes produced by $CaBr_2$, the effect being due to the bromine. It will be recalled that Greene (1899) and Howell (1901) also found that heart muscle will pulsate in pure solutions of cane sugar and dextrose, and I find that the heart of *Salpa* and the branchial arms of *Lepas* will also pulsate in dextrose or glycerin. In his former papers Loeb maintained that rhythmic pulsation was impossible in non-ionizable solutions, but his views appear to have changed upon this point.

EFFECTS OF CALCIUM IN RESTORING PULSATION.

We have the well-known experiment of Howell (1898) and others showing that when heart muscle has ceased to beat in Ringer's solution it may be made to beat again for a short time by adding any calcium salt. This is also true for *Cassiopea*, for the Medusa will pulsate for a short time in any solution containing Na and K in amounts found in sea-water, and then after all pulsations have ceased they can be revived by adding calcium. This is illustrated in the following list of trials (table 3), wherein if the sodium chloride was replaced by any

* Taken alone calcium inhibits or fails to stimulate pulsation, but in combination with sodium chloride and potassium, as in $NaCl + KCl + CaCl_2$, it becomes a powerful stimulant.

other salt this was made isotonic with the NaCl of sea-water. The potassium was so introduced as always to give the same amount of the element (K) as is found in sea-water.

TABLE 3.—How calcium revives rhythmical pulsation in *Cassiopea* after all movement has ceased in solutions containing Na or Li, isotonic with the NaCl of sea-water, and potassium in the same amount as is found in sea-water.

Normal Medusæ taken from sea-water and placed in—	They ceased to pulsate in—	Were restored to pulsation by the addition of any of the following calcium salts, tried separately.
NaCl + KCl	About 120 minutes.....	CaCl ₂ , CaSO ₄ .
NaCl + K ₂ SO ₄	20 to 30 minutes. Very rapid pulsation at first, followed by periods of rest and activity.	CaSO ₄ , CaCO ₃ , CaCl ₂ , or CaH ₂ O ₂ .
NaCl + K ₂ CO ₃	12 to 18 minutes. Pulsation not so rapid as in NaCl + K ₂ SO ₄ .	Very active pulsation restored by CaSO ₄ , CaCl ₂ , or CaH ₂ O ₂ .
NaCl + KClO ₃	4 to 10 minutes. Pulsation not very rapid at first. Slower than in NaCl + K ₂ CO ₃ .	CaSO ₄ , CaCl ₂ , or CaH ₂ O ₂ .
Na ₂ CO ₃ + K ₂ CO ₃	3 to 7 minutes. Pulsation slow and weak.	CaCO ₃ revived weakly.
NaNO ₃ + KNO ₃	Less than 1 minute. Pulsation rapid at first.	CaCl ₂ or CaH ₂ O ₂ . Some of the Medusæ did not revive pulsation.
LiCl + KCl.....	1 to 6 minutes. Pulsated slowly at first.	CaCl ₂ . All three Medusæ revived weakly.

Table 3 shows that *Cassiopea* pulsates longer and more rapidly in a solution of NaCl + KCl than in any other solution named in the above table. Also, sodium and potassium *nitrates* are more injurious than a solution in which the sodium is replaced by an isotonic amount of lithium. Evidently the *anions* as well as the *cations* of the salts have a decided influence upon the rhythmical movement. This is also shown by the fact that Medusæ pulsate longer and with greater regularity of movement in NaCl + K₂SO₄ + CaSO₄ + CaCO₃ than they do if we omit the CaCO₃ and replace it by an equivalent amount of CaSO₄. It will be recalled that Rogers (1905, p. 249) found that the addition of small amounts of Na₂CO₃ or NaOH to solutions have a beneficial effect in maintaining the rhythm of the crab's heart, and he attributes this effect to the neutralization of small amounts of free acid in the solutions. Ammonia, KOH, or NaOH in small amounts have, however, little effect upon the rhythm of *Cassiopea*, but if the sea-water be rendered almost neutral by HCl (it is normally decidedly alkaline at Tortugas) the pulsations of the Medusæ lose energy, and finally the rate declines, and movements, although regular, are feeble and slow. Thus the rates of three Medusæ declined in six hours from 37-50 to 13-17 per minute, due to the effect of a minute quantity of HCl in the sea-water, causing it to become almost neutral, but still alkaline to litmus test. It seems improbable, how-

ever, that the addition of CaCO_3 , which improves the regularity of pulsation of Medusæ in $\text{NaCl} + \text{K}_2\text{SO}_4$, has only the effect of neutralizing acids. Distilled water and the purest obtainable salts were used in making solutions and there is no reason to suppose that there were any more free acids in the solutions than in the natural sea-water itself.

Physiologists have generally assumed (see Howell, Text-Book of Physiology, p 502) that the chief rôle of sodium chloride in pulsation is to maintain the osmotic pressure of the solution. I find, however, that *Cassiopea* pulsates more than 24 minutes in a solution of Na_2SO_4 containing the same amount and proportion of Na as is found in sea-water; whereas it will not pulsate more than 14 minutes in a solution of Na_2SO_4 isotonic with sea-water. This would lead one to believe that the sodium of the sea-water exerts a specific action, and that the salts have a specific chemical effect independent of their osmotic action. Indeed, the various salts of sodium behave very differently; for example, *Cassiopea* pulsates less than 1 minute in Na_2CO_3 , 11 to 12 minutes in NaClO_3 , and more than half an hour in NaCl , or NaNO_3 isotonic with sea-water.

When pulsations have ceased in 96 c.c. $\text{H}_2\text{O} + 2.7$ grams $\text{NaCl} + 0.085$ gram K_2SO_4 they may be revived temporarily by Na_2CO_3 , more NaCl , KCl , K_2CO_3 , or weak acids. These cause only a few irregular contractions, however, and are quite different in their effects from the long, steady revival of pulsation upon the addition of calcium. Potassium is, however, capable of reviving temporary pulsation in any solution which lacks magnesium, but if magnesium be present it can not usually revive pulsation. It is interesting to observe that after Medusæ have ceased to pulsate in the $\text{NaCl} + \text{K}_2\text{SO}_4$ and have been revived by potassium, they will not again pulsate upon the addition of calcium to the solution. On the other hand, if pulsations have ceased and have been revived by adding more sodium, they can be revived a second time by adding calcium. Potassium in excess at first stimulates the disk powerfully, but soon it poisons the tissues and inhibits the sensibility, while calcium is not a stimulant, but is necessary for pulsation in connection with sodium and potassium. The chief rôle of calcium is, however, to counteract the inhibiting effect of the magnesium.

This is shown by the fact that if we were to place *Cassiopea* in normal sea-water, and then add sufficient sodium oxalate to precipitate the calcium, pulsation ceases in less than five minutes, but is quickly restored if we place the Medusa in $\text{NaCl} + \text{KCl} +$ sodium oxalate, or in $\text{NaCl} + \text{KCl}$. Pulsation is not restored, however, if we place the Medusa in $\text{NaCl} +$ magnesium. These experiments prove that the

pulsation is inhibited by the *magnesium* of the sea-water, not merely by the loss of calcium; for pulsation may be restored in solutions which lack calcium. They also show that when calcium is present the magnesium does not inhibit pulsation.

EFFECTS OF MAGNESIUM UPON PULSATION.

The magnesium salts in sea-water retard pulsation in *Cassiopea*, and reduce its rate, amplitude, and energy. *Cassiopea* pulsates at about twice its normal rate in a solution resembling sea-water but lacking magnesium, but if we add the magnesium to this solution the Medusa immediately pulsates at normal rates. Also, an excess of magnesium added to sea-water causes the rate and energy of pulsation to decline, although Medusæ will tolerate 1.6 grams $MgCl_2$ in 100 c.c. sea-water, and will pulsate *slowly* for half an hour without the least apparent injury, their normal rate being regained in a few minutes after they are returned to pure sea-water. Magnesium acts only as a restrainer, never stimulating the disk of *Cassiopea*. When the disk, deprived of marginal sense-organs, is placed in a solution of $MgCl_2$ or $MgSO_4$ isotonic with sea-water it does not pulsate. Indeed, the rate of pulsation of normal Medusæ in natural sea-water becomes successively slower as we add more and more magnesium.

The rôle of magnesium is, however, an essential one in pulsation, for it counteracts the strongly stimulating action of the combination of NaCl, K, and Ca which occurs in Ringer's solutions, or in sea-water. For example, if we place *Cassiopea* in a solution of $NaCl + KCl + CaCl_2$ in amounts and proportions found in sea-water* the Medusa is highly stimulated and pulsates at fully twice its normal rate. If now we precipitate the magnesium in its tissues in any manner,† the stimulating effect of the sodium, potassium, and calcium is unchecked, and after a short period of violent pulsation the Medusa passes into a strong sustained tetanus and remains motionless, with its bell highly contracted.

I find also that sustained pulsation is impossible in the heart of *Salpa* or the branchial arms of *Lepas* unless magnesium be present, and that in these cases also $NaCl + KCl + CaCl_2$ is a powerful stimulant, producing rapid but not permanently sustained pulsation, but normal sustained pulsation is attained on the addition of magnesium. It appears, therefore, that a Ringer's solution is not an inorganic food for the pulsating organ, as has been commonly assumed by physiologists.

* 100 NaCl + 2.2 KCl + 3 CaCl₂ all of $\frac{1}{5}$ n concentration, as in Van 't Hoff's solution.

† The magnesium may be precipitated by a small amount of $Ba(OH)_2$, KOH, NaOH, or sodium phosphate + ammonia + ammonium chloride, etc.

ogists, but is only a stimulant which in the end produces injurious effects by the withdrawal of magnesium through osmosis. It can not sustain permanent pulsation unless a certain proportion of magnesium be present to preserve a balance.

It is interesting to see that Meltzer and Auer (1905-'06) find that magnesium affects the nervous system in such manner as to produce in mammals a deep anesthesia, with relaxation of all the voluntary muscles. It is inhibitory, never stimulating in its effects, but it does not interfere with the trigeminal reflex inhibition of respiration. Also, Carlson (1906) finds that magnesium and calcium depress the ganglionic rhythm of the heart of *Limulus* without primary stimulation. Indeed, the anesthetic effects of magnesium salts upon aquatic animals have been known since Tullberg's researches in 1892.

Macallum (1903) finds that there is about 10 per cent less magnesium in the bodies of *Cyanea* and *Aurelia* than in sea-water. Rogers (1905), however, found that the optimum solution for the continuance of rhythmic movement of the crab's heart contains fully as much magnesium as the sea-water.

Loeb (1906) finds that in *Polyorchis* the NaCl + KCl + CaCl₂ of sea-water produce sustained contraction without pulsation, and that magnesium is necessary in order to overcome the tetanus and permit of rhythmical pulsation. Also, this effect of magnesium can be inhibited by the addition of an equivalent amount of calcium or potassium. Also, Romanes (1885) found that the vigor of the swimming movements of *Sarsia* is impaired in a pure NaCl solution of the same strength as that of the sodium chloride in sea-water, but that this vigor of movement is *somewhat restored* by adding MgSO₄ to the same amount found in sea-water. In the case of *Cassiopea* all movement would cease in less than six minutes in NaCl + MgSO₄ in amounts found in sea-water; whereas irregular pulsation continues for half an hour in NaCl alone, although after that the Medusæ would show periods of quiescence alternating with periods of pulsation. I find also that 1 per cent magnesium added to sea-water slowly lowers the rate of the rhythmical movement of the arms of *Lepas*. It seems probable, therefore, that magnesium, while always inhibitory, plays a somewhat different rôle in the efficiency of its control over rhythmical movement in various animals.

EFFECTS OF POTASSIUM UPON PULSATION.

Potassium in small amounts temporarily stimulates and then retards pulsation. Unlike magnesium or calcium in excess, it is quite poisonous. All potassium salts, with the exception of those consisting

of combinations of potassium with magnesium and calcium, are powerful stimulants to the disk of *Cassiopea*, causing strong but temporary contractions. Repeated touches of a crystal of K_2SO_4 to any one spot on the sub-umbrella of *Cassiopea* soon renders the place insensitive to further stimulation of any sort. For example, a single spot upon a disk, deprived of sense-organs, was touched 17 times, in rapid succession, with a crystal of K_2SO_4 and each time a contraction resulted. The next 2 touches, however, gave no contractions; then followed 2 touches with contractions, 7 without contractions, 1 with, and finally 11 without contractions, etc.

If normal *Cassiopea* with sense-organs intact be placed in sea-water + 0.125 to 1.55 per cent K_2SO_4 , $KClO_3$, KCl , or K_2CO_3 they immediately pulsate at an abnormally high rate, but the movement soon loses force, and the disk comes to rest *expanded* with the mouth-arms strongly *contracted*. Medusæ in 0.125 per cent excess of K_2SO_4 will pulsate quickly at first and then more and more slowly, so that at the end of 13 hours their rates are only about half the normal rate in sea-water. On the other hand, Medusæ in sea-water + 1.55 per cent K_2SO_4 will pulsate with great activity for a few moments, but will cease all movement in less than 4 minutes. Also, a solution of K_2SO_4 isotonic with the $NaCl$ of sea-water *at once reduces* the rate of pulsation of normal Medusæ and quickly brings them to rest without an initial display of excitement. It appears that a small excess of potassium acts as a temporary stimulus, whereas a large excess at once inhibits pulsation. It is possible that the initial stimulation is due to the physiological reaction of the tissues against the injurious effects of the potassium. Temporary activity is commonly called forth in animals by sudden injurious stimuli. In this connection it is interesting to see that Carlson (1906) finds that potassium is a primary stimulant for the heart of *Limulus*, but its action is quickly followed by depression.

An excess of 1 per cent potassium in the sea-water quickly lowers the rate of movement of the arms of *Lepas*, causes tetanus-like contraction, and may be fatal in 10 minutes.

The effect of potassium upon the disk without marginal sense-organs is, however, different from its effect upon the normal, perfect *Cassiopea*, for disks without sense-organs are *actively stimulated* into pulsation for a short time in all excess of potassium from sea-water + 0.25 per cent K_2SO_4 to a pure solution of K_2SO_4 , or KCl , isotonic with the $NaCl$ of sea-water. Perfect Medusæ, however, show no increase in rate of pulsation in isotonic K_2SO_4 , but *steadily* decline. It seems probable, therefore, that a strong excess of potassium impairs

the activity of the marginal sense-organs sooner than it affects the disk itself. The disk without sense-organs will, however, cease to pulsate in a solution resembling sea-water but lacking potassium quite as quickly as will the perfect Medusa. It would seem, therefore, that the sense-organs and the sensory surface of the sub-umbrella are equally intolerant of a lack of potassium in the sea-water. This is interesting in view of the fact that the disk without sense-organs is relatively indifferent to calcium, or magnesium, and will pulsate either in sea-water saturated with CaSO_4 , in normal sea-water, or for more than an hour in a solution resembling sea-water but without calcium. The Medusa with sense-organs intact, however, ceases to pulsate in a solution containing all of the elements of sea-water excepting calcium in less than six minutes, but will pulsate in sea-water saturated with CaSO_4 . It is evident that the *accurate balance* between the proportions of calcium, potassium, and sodium insisted upon by Loeb as being *necessary* for the continuance of pulsation need not be maintained and yet pulsation may continue. As Howell has pointed out, marine animals are attuned to the sea-water in which they live, and any change in its constituents must be expected to affect them more or less adversely. Loeb's theory of the influence of ions upon pulsation, although of fundamental value, unfortunately neglects, in some measure, to consider the effects of the salts as a whole. As we shall soon see, however, *Cassiopea* will pulsate for at least 30 minutes in a pure $\frac{5}{8}\text{n}$ NaCl solution, whereas it is paralyzed in less than a minute in an isotonic solution of Na_2CO_3 . Indeed, the various potassium salts stimulate in different degrees. KI, K_2SO_4 , and KCl are powerful stimulants, whereas KMnO_4 , $\text{KAl}(\text{SO}_4)_2$, and potassium metabisulphite produce weak contractions.

Matthews (1905) concludes that valence, as such, either of the anion or cation, is of secondary or no importance in determining either the toxic or antitoxic action of the salt.

Loeb (1900) concluded that the potassium and calcium ions of sea-water prevent the center of the bell of *Gonionemus* from pulsating rhythmically. His experiment, however, does not prove this point, for he found that the center of the bell of *Gonionemus* would pulsate in $\frac{5}{8}\text{n}$ NaCl, but not in sea-water; and thus he concluded that the K and Ca of sea-water inhibited pulsation,* but he neglected to consider

*While this paper was in press Loeb (1906: Journ. Biol. Chemistry, vol. 1, p. 431) concludes that *magnesium* and calcium inhibit the center of *Gonionemus*. In so far as the effect of magnesium is concerned his view now accords with the researches of Tullberg (1892), Meltzer and Auer (1905-06), and Mayer (1906) that magnesium is anesthetic or inhibitory.

the effects of magnesium. I find, indeed, that the center of the bell of *Gonionemus* does occasionally pulsate spontaneously in sea-water, and always pulsates actively whenever one touches it with a crystal of KCl or K_2SO_4 . It is not stimulated by the sea-water, but the inhibitory effect of the sea-water is probably due to magnesium, not to potassium or calcium. The center of *Gonionemus* is strongly stimulated by Na salts, and the reason it pulsates in $\frac{5}{8}n$ NaCl is that magnesium, as well as calcium and potassium, is withdrawn from the tissues by osmosis by the pure NaCl solution, thus giving a preponderating influence to the Na, which acts as a stimulant. Indeed, Loeb himself found that the center of *Gonionemus* pulsates slowly in 96 c.c. $\frac{5}{8}n$ NaCl + 2 c.c. $\frac{5}{8}n$ KCl + 2 c.c. $\frac{10}{8}n$ $CaCl_2$. I also find that *Gonionemus* pulsates slowly but without pauses in a solution resembling sea-water* but lacking magnesium salts. The characteristic pauses which occur periodically in the normal pulsation of *Gonionemus* are thus due to magnesium. Magnesium fails to stimulate the center of *Gonionemus*, and, indeed, if the center be touched with $MgSO_4$ or $MgCl_2$ it deadens the part touched, so that it responds weakly or not at all to such powerful stimuli as the touch of a crystal of NaCl or K_2SO_4 . The disk of *Cassiopea* deprived of sense-organs behaves exactly as does *Gonionemus*, for it does not pulsate spontaneously in sea-water but does so in $\frac{5}{8}n$ NaCl, or in any solution containing NaCl + K or Ca, but lacking magnesium. If, however, we stimulate it with KCl or K_2SO_4 it gives some active pulsations in sea-water; or better still, if we cut partial rings in its sub-umbrella and then stimulate it mechanically by a shock, it pulsates indefinitely in sea-water.

It is significant that the disks of *Aurelia* and *Dactylometra*, when deprived of marginal sense-organs, still pulsate irregularly in sea-water; and the disks of both of these Scyphomedusæ sometimes respond by weak contractions to $MgSO_4$ and $MgCl_2$.† They therefore pulsate in sea-water as soon as they recover from the shock-effects resulting from loss of their marginal sense-organs, because their disks are stimulated by everything (Na, K, Mg) in the sea-water, except the calcium, which, taken singly, exerts only a slight inhibitory action. In the case of *Cassiopea*, *Gonionemus*, and *Polyorchis* the sea-water is a balanced fluid. * Na stimulates while Mg inhibits pulsation. Ca in connection with Na and K is necessary to, and stimulates, pulsation.

* 96 c.c. H_2O + 2.7 grams NaCl + 0.124 $CaSO_4$ + 0.01 $CaCO_3$ + 0.085 K_2SO_4 .

† These reactions are so irregular and the Medusæ so extremely sensitive to mechanical effects that I am in doubt concerning the validity of this statement. It may be that the occasional response is due to some chemical shock-effect.

The disk of *Cassiopea* does not pulsate in sea-water, because the sea-water as a whole does not stimulate it. Disks of *Aurelia* and *Dactylometra* behave in sea-water as if they were weakly stimulated.

Howell (1901, pp. 200, 204) concludes as a result of his own work and a review of the labors of others that potassium acts somewhat as an inhibitory agent upon the rhythmical pulsation of the heart muscle of the ventricle of the terrapin, for it lengthens the period of diastole, causing the rate to become slower,* but at the same time the heart muscle pulsates longer when potassium is present than it does when only sodium and calcium are present. A small excess of potassium in physiological doses is not toxic in its effects, yet it inhibits the pulsation of the heart muscle; but the muscle will beat again in solutions containing less potassium or more calcium. Other physiologists conclude that small amounts of potassium stimulate "the vertebrate heart." (See Carlson, 1906, p. 397.)

It is interesting to observe that Macallum (1903) finds that the bodies of *Cyanea* and *Aurelia* contain considerably more potassium than does sea-water. He found the various elements to exist in the following proportions :

	Na.	Ca.	K.	Mg.
Sea-water.	100	3.84	3.66	11.99
<i>Cyanea arctica</i> . . .	100	3.86	7.67	11.31
<i>Aurelia flavidula</i> ..	100	4.13	5.18	11.43

GENERAL INFLUENCE OF CALCIUM UPON PULSATION.

Calcium is essential for pulsation on account of its power to counteract the inhibiting influence of magnesium. Its importance in connection with sodium and potassium in maintaining pulsation has been known since Ringer's important experiments in 1883.

If we place perfect Medusæ of *Cassiopea*, with marginal sense-organs intact, in a solution resembling sea-water but merely lacking calcium,† the Medusæ pulsate more and more weakly, and all movement ceases in less than 6 minutes. The Medusæ are not poisoned, however, for if, after remaining motionless for fully an hour we add calcium to the solution, or restore the Medusæ to sea-water, pulsation is resumed almost at once, beginning feebly at first but rapidly regaining its normal vigor in a few minutes.

* I find that in the embryo loggerhead turtle, 14 days old, the heart pulsates *faster* in NaCl + KCl than it does in pure NaCl.

†96 c.c. CH₂O + 2.7 grams NaCl + 0.37 gram MgCl₂ + 0.16 gram MgSO₄ + 0.085 gram K₂SO₄, or 100 NaCl + 2.2 KCl + 7.8 MgCl₂ + 3.8 MgSO₄, all of $\frac{5}{8}$ n concentration.

The Medusæ are, however, inhibited from pulsating by the *presence* of magnesium, not by the mere *absence* of calcium; for if magnesium be absent, calcium may also be absent and the Medusæ will pulsate fully two hours.

A large excess of calcium lowers the rate of pulsation of *Cassiopea*, after a momentary increase. The inhibitory effect of calcium is, however, far less marked than that of magnesium, or than the final toxic effect of potassium. For example, if we add $\text{CaSO}_4 + \text{CaCO}_3$ to sea-water at 82°F. , to saturation, normal perfect Medusæ of *Cassiopea* pulsate at about two-thirds their normal rate after being in this solution $12\frac{1}{2}$ hours. One gram of CaCl_2 in 100 c.c. sea-water also slightly reduces the rate of pulsation without injurious effects, recovery being almost immediate in normal sea-water. Perfect *Cassiopea* with sense-organs intact when placed in a pure solution of CaCl_2 isotonic with the NaCl of sea-water ceases to pulsate in 10 seconds, and can not be restored to pulsation by being placed in $\text{NaCl} + \text{K}_2\text{SO}_4$ in amounts found in sea-water. A strong solution of K_2SO_4 in NaCl , however, revives them into active pulsation. Evidently their sensibility to stimuli is impaired but not destroyed.

Calcium salts never stimulate the disk of *Cassiopea* into pulsation, even when placed upon it in concentrated solutions.

We see that calcium, while not of itself a stimulant, is *necessary* to pulsation and is a stimulant *in connection* with sodium and potassium. An excess of calcium tends to retard pulsation, but even a saturated solution of CaSO_4 in sea-water exerts no appreciable toxic influence. It is far more important to pulsation than potassium; for *Cassiopea* will pulsate for more than an hour with irregular periods of rest and activity in the absence of potassium, but in the absence of calcium pulsation ceases in less than 6 minutes. This importance is due solely to the remarkable ability which calcium has to counteract the inhibiting effect of magnesium.

EFFECTS OF SODIUM UPON PULSATION.

All of the sodium salts are *weak* stimulants to the disk of *Cassiopea* deprived of its marginal sense-organs, producing not very powerful contractions. The sodium salts, however, vary considerably in their stimulating power, NaCl or NaOH giving strong and Na_2CO_3 or Na_2SO_4 weak contractions.

The disk of *Cassiopea* deprived of marginal sense-organs pulsates for about 20 minutes in a pure $\frac{5}{8}\text{n}$ NaCl solution, and also in $\text{NaCl} + \text{K}_2\text{SO}_4$ or $\text{NaCl} + \text{K}_2\text{SO}_4 + \text{CaSO}_4$ or $\text{NaCl} + \text{CaSO}_4$.*

* The proportions of Na, Ca, and K were such as are found in sea-water.

It will not pulsate, however, in $\text{NaCl} + \text{MgSO}_4$ or MgCl_2 , or both, and it is evident that the magnesium salts contained in sea-water counteract the stimulating effect of the sodium. Disks that have ceased to pulsate in $\frac{5}{8}\text{n}$ NaCl will revive a few pulsations if supplied with calcium, or with a strong *excess* of potassium, or both, but no revival results when magnesium is added to the NaCl solution. Indeed, it may be said of the sea-water that the chief stimulant, owing to its large amount, is sodium chloride, and the chief inhibitor of pulsation is the magnesium. As is well known, however, pure sodium chloride solutions can not sustain pulsation, for in all known cases of rhythmical movement from that of *Medusæ* to that of the vertebrate heart, calcium and potassium must be associated with the sodium, and I find that *magnesium* must also be present to *restrain* the highly stimulating influence of the combination of sodium, calcium, and potassium. Indeed, in order to pulsate rhythmically an organ must be in that delicately balanced state known to physiologists as being upon the threshold of stimulation. When in this condition a constantly accumulating internal stimulus, which is reduced at each contraction, will maintain rhythmical pulsation.

Normal *Medusæ* of *Cassiopea* with marginal sense-organs intact will pulsate for a short time with abnormal rapidity in a pure $\frac{5}{8}\text{n}$ NaCl solution, but their rate quickly declines so as to become abnormally slow, and in about 10 minutes they begin to pulsate only at intervals with longer and longer periods of rest between periods of pulsation. Practically all movement ceases at the end of about 30 minutes. Little or no toxic effect is produced, however, for recovery is almost instantaneous in sea-water, and pulsation can be revived, even after several hours, by the addition of any calcium salt to the NaCl solution.

Pulsation of normal *Cassiopea* ceases in 1 to 6 minutes in a solution containing the amounts of NaCl and $\text{MgSO}_4 + \text{MgCl}_2$ found in sea-water, but it can sometimes be revived temporarily by adding potassium, or always by the amount of calcium found in sea-water.

Normal *Medusæ* of *Cassiopea* are but little affected by an excess of NaCl in the sea-water, and will pulsate for more than 18 hours in sea-water + 1 per cent excess of NaCl . Their pulsation, however, becomes somewhat irregular, although of practically normal average rate, but the mouth-arms are strongly and abnormally contracted. Recovery in sea-water is, however, very rapid and no apparent toxic effects are produced. A *Medusa* in sea-water + 1.55 per cent excess of NaCl pulsates with abnormal rapidity for half an hour, and although shriveled, recovers quickly on being replaced in normal sea-water.

When we proportionately reduce the sodium chloride and magnesium, but at the same time maintain the amounts of calcium and potassium of the sea-water, the rate of pulsation and general energy of the Medusæ steadily decline. This was done by diluting sea-water with distilled water containing the amounts of calcium and potassium found in sea-water, as is described on page 18. If we simply dilute the sea-water with distilled water the rate of pulsation does not decline so rapidly, and the injurious effects are not so pronounced.

These experiments show that a relative excess of Ca and K retards pulsation, even when the *actual amounts* of Ca and K are such as are found in sea-water.

Cassiopea will pulsate longer in $\text{LiCl} + \text{K}_2\text{SO}_4 + \text{CaSO}_4$ than in a solution wherein the NaCl is replaced by Na_2CO_3 . In these solutions the LiCl and Na_2CO_3 were isotonic with the NaCl of sea-water, while the amounts of K and Ca were the same as are found in sea-water. The Medusæ ceased pulsating in about 6 minutes in the LiCl solution, but it seems somewhat remarkable, in illustrating the effects of *salts as a whole*, that LiCl should replace the NaCl with less injury than Na_2CO_3 .

We have seen that NaCl in excess or in pure solutions has very little toxic effect upon *Cassiopea*. This appears remarkable, for its marked toxic effects have been made known by Loeb, Lingle, Cushing, and others upon a number of animals, and I find that pure solutions of NaCl have a very rapidly injurious effect upon the movement of the branchial arms of *Lepas*. We must remember, however, that *Cassiopea* normally lives in semi-stagnant salt-water lagoons where considerable range in density must take place through evaporation and rainfall. It is also one of the most hardy of marine animals and will survive without serious effects several minutes' immersion in sea-water containing such poisons as 0.1 per cent KCN.

It will be recalled that Macallum (1903) found that while the amount of NaCl in brackish estuaries might change greatly with the condition of the tide, the amount of NaCl in the bodies of the *Aurelia* and *Cyanea* remained practically constant. It is therefore possible that *Cassiopea* may resist osmosis of NaCl to some extent and thus avoid its possibly toxic influences.

We conclude that NaCl is a stimulant and is counteracted in this respect by the magnesium of sea-water so as to produce a balanced solution. It can not maintain pulsation except in *connection* with calcium and potassium, in combination with which it forms a powerful stimulant which produces a rapid but only temporary pulsation, magnesium being necessary to reduce and sustain its action.

ARTIFICIAL SEA-WATER AND THE EFFECTS OF THE SALTS OF SEA-WATER, AS A WHOLE, UPON PULSATION.

In the experiments upon *Cassiopea* the solutions containing some or all of the chief constituents of sea-water were made up in accordance with the formula given by Dittmar (1884)*, and also according to Van 't Hoff's formula ($100 \text{ NaCl} + 2.2 \text{ KCl} + 7.8 \text{ MgCl}_2 + 3.8 \text{ MgSO}_4 + 3 \text{ CaCl}_2$), all of $\frac{5}{8}$ n concentration.

Medusæ pulsate normally in an artificial sea-water made according to Van 't Hoff's formula, but pulsation is somewhat irregular in a sea-water made according to Dittmar's formula. Table 4 shows the results of experiments with Dittmar's formula, and table 5 gives the results obtained by using Van 't Hoff's formula.

Tables 4 and 5 show the effects upon *Cassiopea* of various solutions containing one or more of the constituents of sea-water. It will be apparent that *magnesium* is the chief restrainer of pulsation, and that it prevents the spontaneous contraction of disks deprived of marginal sense-organs and retards pulsation in perfect Medusæ. When magnesium is present the absence of calcium quickly stops pulsation, but when magnesium is *absent* we may have calcium also absent and the Medusæ will pulsate for a considerable time. It is apparent, therefore, that calcium assists the NaCl to counteract the retarding influence of magnesium. This is also shown by the fact that Medusæ pulsate for a long time in Na + Mg + Ca, whereas all movement ceases very soon in Na + Mg.

Potassium, however, does not assist the NaCl to resist the stupefying influence of magnesium, for Medusæ cease to pulsate almost as soon in Na + Mg + K as they do in Na + Mg. Potassium serves mainly to stimulate movement in *connection with both* calcium and sodium; thus Na + K and Na + Ca give temporary pulsations at about normal rate; whereas Na + Ca + K gives strong pulsations at fully twice the normal rate, but these can not be sustained indefinitely unless magnesium be present to counteract the too powerful stimulating effects of the Na + Ca + K. A Ringer's solution is only a powerful stimulant, and can not sustain pulsation indefinitely unless tempered by magnesium. Potassium has little power to revive pulsation, whereas calcium possesses this power to a marked degree; thus, when pulsations have ceased in NaCl they can always be revived by calcium, but at best only a very few isolated contractions can be revived by potassium in the amount and proportion found in sea-water.

*Reports of voyage of H. M. S. Challenger, Chemistry, vol. 1, p. 204.

TABLE 4.—*Effects upon the rhythmical pulsation of Cassiopea exerted by solutions containing Na, Ca, K, and Mg in proportions and amounts found in average sea-water.*

[1,000 grams of sea-water is supposed to contain 965.6 H₂O + 26.74 NaCl + 1.24 CaSO₄ + 0.12 CaCO₃ + 0.85 K₂SO₄ + 3.74 MgCl₂ + 1.64 MgSO₄ + 0.07 MgBr (see W. Dittmar (1884) : Composition of Ocean Water, Reports H. M. S. "Challenger," Chemistry, vol. 1, p. 204).]

Composition of the solution.	Effect produced upon perfect Medusæ by adding the salts to make sea-water, after the Medusæ have come to rest.
NaCl.....	Pulsation is always revived by adding CaSO ₄ or CaCO ₃ + CaCO ₃ or CaSO ₄ + K ₂ SO ₄ . Revival ensues from adding Ca, or Ca + K, never from Mg.
NaCl + CaSO ₄	Occasionally a few pulsations are revived by adding K ₂ SO ₄ , CaSO ₄ , or CaCO ₃ . Mg never revives pulsations.
NaCl + CaSO ₄ + CaCO ₃	K ₂ SO ₄ occasionally revives a few pulsations; Mg never revives pulsations.
NaCl + K ₂ SO ₄	Pulsation is <i>always</i> revived by any calcium salt, <i>never</i> by magnesium.
NaCl + K ₂ SO ₄ + CaSO ₄	Pulsation is rendered more regular by CaCO ₃ . It is rendered slower, or stopped, by MgSO ₄ or MgCl ₂ .

Paralyzed, quiescent disks without sense-organs, taken from sea-water and placed in the solution, behave as follows:

In newly cut disks 15 to 30 irregular contractions set in, but these cease in about three minutes and the disk remains motionless. Disks which have regenerated for two or more days may pulsate for hours in an irregular manner.

In newly cut disks a few pulsations during not more than 2 minutes. Regenerating disks pulsate longer.

In new disks a few weak contractions. Regenerating disks pulsate longer in an irregular manner.

Newly cut disks give a few very strong pulsations lasting about 3 minutes. Regenerating disks pulsate longer, but in an irregular manner.

Newly cut disks give about 18 pulsations, then quiescence. Disks two or more days old may pulsate for hours in an irregular manner.

Pulsation of perfect Medusæ taken from sea-water and placed in the solution.

For a few moments it pulsates at about double the normal rate. Then the rate declines, and soon alternating periods of rest and pulsation set in. The periods of rest become longer, and all movement practically dies out in 30 minutes.

Effect similar to that of NaCl, but the rhythmical movement is usually more prolonged. Practically all movement dies out in about half an hour.

Behavior similar to that in NaCl + CaSO₄.

Rapid at first, then slow, then periods of quiescence alternating with pulsation. All movement dies out in about 20 minutes.

Active, sustained, *irregular* pulsation at fully twice the normal rate. Pulsation at an abnormally rapid rate continues for more than one hour.

TABLE SHOWING EFFECTS OF SALTS.

<p>NaCl + K₂SO₄ + CaCO₃.....</p>	<p>Active, <i>irregular</i> pulsation at about double the normal rate. Periods of rest alternating with periods of active pulsation soon set in. These continue for more than an hour.</p>	<p>Newly made disks give a few pulsations then, quiescence. Regenerating disks, two or more days old pulsate irregularly, sometimes for hours.</p>	<p>Pulsation is made regular, without periods of rest, by adding CaSO₄. Mg salts, in the absence of CaSO₄, reduce or stop pulsation.</p>
<p>NaCl + K₂SO₄ + CaSO₄ + CaCO₃.</p>	<p>Violent sustained pulsation at about twice the normal rate. Pulsation continues more than an hour without periods of rest.</p>	<p>Recently cut disks give a few pulsations, then quiescence. Disks two or more days old are strongly stimulated and pulsate irregularly for many hours.</p>	<p>Pulsation is reduced, or stopped, by Mg salts.</p>
<p>NaCl + MgSO₄ + MgCl₂.....</p>	<p>All movement ceases in less than 6 minutes.</p>	<p>No pulsations.</p>	<p>A few pulsations are sometimes revived by K₂SO₄, but prolonged active pulsation is revived by calcium salts.</p>
<p>NaCl + MgCl₂ + CaSO₄.....</p>	<p>Periods of quiescence alternating with activity. Practically all movement dies out in about 50 minutes. Pulsation not rapid.</p>	<p>Not tried.....</p>	<p>Not tried.</p>
<p>NaCl + MgSO₄ + MgCl₂ + CaSO₄.</p>	<p>Periods of quiescence alternating with activity. Whenever the Medusa comes to rest its mouth-arms contract, but they expand soon after movement is resumed. Pulsates thus for more than an hour. The rate is normal.</p>	<p>No pulsations; no effect.....</p>	<p>K₂SO₄ renders movement slightly more regular.</p>
<p>NaCl + MgSO₄ + MgCl₂ + K₂SO₄..</p>	<p>Rapid pulsation for a moment, then more and more slow. All movement ceases in less than 6 minutes.</p>	<p>No contractions; no effect.....</p>	<p>Pulsation is always revived, even after 1½ hours quiescence by calcium.</p>
<p>NaCl + MgSO₄ + MgCl₂ + CaSO₄ + CaCO₃</p>	<p>Periods of activity alternating with resting periods. For the first half hour the periods of rest are about equal to those of activity. The rate of pulsation is about normal. Pulsation ceases at the end of about 1½ hours.</p>	<p>No contractions.....</p>	<p>Adding K₂SO₄ renders the periods of rest shorter, and the movement more uniform. Recovery very rapid in sea-water.</p>
<p>NaCl + MgSO₄ + MgCl₂ + CaSO₄ + K₂SO₄</p>	<p>Long periods of normal pulsation alternating with short resting periods. Pulsation usually continues for several hours.</p>	<p>No contractions.....</p>	<p>Adding CaCO₃ renders pulsation more regular. Recovery is instantaneous in natural sea-water.</p>

TABLE 4.—*Effects upon the rhythmical pulsation of Cassiopea exerted by solutions, etc.*—Continued.

Composition of the solution.	Pulsation of perfect Medusæ taken from sea-water and placed in the solution.	Paralyzed quiescent disks without sense-organs, taken from sea-water and placed in the solution, behave as follows:	Effect produced upon perfect Medusæ by adding the salts to make sea-water, after the Medusæ have come to rest.
NaCl + MgSO ₄ + MgCl ₂ + CaCO ₃ + K ₂ SO ₄ .	Short periods of pulsation, alternating with increasingly long periods of quiescence. Practically all movement ceases in about 10 minutes.	No contractions	Pulsation is rendered nearly normal by adding CaSO ₄ , or perfectly normal, at once, by replacing the Medusa in sea-water.
K ₂ SO ₄ isotonic with the NaCl of sea-water.	Pulsation rapidly declines without even momentary acceleration. All movement dies out in about 3 minutes.	Active contractions for about 3 minutes, followed by tetanus.	Pulsation can not be revived by calcium.
CaCl ₂ isotonic with the NaCl of sea-water.	Medusæ give only 5 to 8 slow pulsations, then all movement ceases.	No effect; no contractions.....	Pulsation can not be revived by calcium.
MgSO ₄ or MgCl ₂ isotonic with the NaCl of sea-water.	Medusæ cease to pulsate almost instantly.	No effect; no contractions.....	Pulsation can not be revived by calcium.
Na ₂ CO ₃ isotonic with the NaCl of sea-water.	Almost instant cessation of all movement.	Pulsation can not be revived by calcium.

TABLE 5.—*Effects upon the rhythmical pulsation of Cassiopea, exerted by solutions containing Na, Ca, K, and Mg in amounts and proportions found in sea-water according to Van 't Hoff's formula, wherein sea-water is supposed to contain 100 NaCl + 2.2 KCl + 7.8 MgCl₂ + 3.8 MgSO₄ + 3CaCl₂, all of $\frac{1}{3}$ n concentration.*

Composition of the solution.	Normal Medusæ taken from sea-water and placed in the solution pulsate as follows :	Disks made by cutting off the marginal sense-organs of <i>Cassiopea</i> behave as follows :
NaCl	Pulsation is abnormally rapid at first, but in from 7 to 10 minutes periods of rest appear and these increase in duration and frequency while the periods of active pulsation decrease. All movement dies out before the end of 45 minutes.	Newly cut disks give a few contractions, then subside into quiescence. Disks two or more days old usually pulsate slowly and irregularly for hours.
NaCl + CaCl ₂	At first the rate is about normal. Periods of rest begin to appear after being about 15 minutes in the solution. These periods of rest increase in duration and frequency so that all movement ceases before the end of 1½ hours.	Disks behave very much as they do in NaCl, but are somewhat more actively stimulated.
NaCl + KCl	Pulsation is abnormally rapid at first, but at the end of about half an hour pauses set in, and these periods of rest gradually increase in length and frequency. All movement ceases after the Medusa has pulsated somewhat more than 2 hours.	Disks behave as they do in NaCl + CaCl ₂ , but are more strongly stimulated.
NaCl + KCl + CaCl ₂	Pulsation is maintained without pauses at fully twice the normal rate for more than 2 hours; then periods of rest are apt to commence. The Medusa pulsates over 4 hours.	Disks are powerfully stimulated, and even newly made disks may commence spontaneous, irregular pulsation which may continue for several hours.
NaCl + MgCl ₂	Pulsation declines steadily and ceases before the end of 6 minutes.	No pulsation.
NaCl + MgSO ₄	Pulsation declines at once and all movement ceases before end of 10 minutes.	No pulsation.
NaCl + MgCl ₂ + MgSO ₄	Pulsation declines rapidly and usually ceases before the end of 30 seconds. Some Medusæ may pulsate longer than 5 but less than 6 minutes. It is restored if we add CaCl ₂ , but not usually by KCl.	No pulsation.
NaCl + MgCl ₂ + MgSO ₄ + KCl.	Pulsation steadily declines and ceases before the end of 6 minutes. It is effectually restored by adding CaCl ₂ .	No pulsation occurs.
NaCl + MgCl ₂ + MgSO ₄ + CaCl ₂ .	Rate normal at first but declines slowly with pauses, so that all movement ceases before the end of 40 minutes. Pulsation is restored by adding KCl.	No pulsation.
NaCl + MgCl ₂ + MgSO ₄ + KCl + CaCl ₂ .	Pulsation is normal as in natural sea-water.	Newly made disks do not pulsate. Disks 2 or more days old pulsate irregularly.

IV. PULSATION OF THE BRANCHIAL ARMS OF LEPAS, THE HEART OF SALPA, AND THE HEART OF THE LOGGERHEAD TURTLE.

The Medusæ are the most primitive of the metazoans which display rhythmical pulsation, and therefore a study of the laws which control their movement is important, for it is practically certain that pulsation began to attain physiological importance in primitive marine animals, and that the vertebrate heart, developed in creatures living in salt water. In the most primitive forms the body pulsates as a whole, but finally pulsation is assumed by or restricted to special organs. It is therefore interesting to consider various sorts of pulsating organs in order to see whether some fundamental conditions may not apply to all of them.

Accordingly studies were made of the pulsation of the heart of the solitary asexual form of *Salpa democratica*, the rhythmical movement of the branchial arms of *Lepas*, and the pulsation of the heart of the embryo loggerhead turtle, *Thalassochelys caretta*, and these varied sorts of pulsation were compared with that of the jellyfish *Cassiopea*.

The results are presented in condensed form in table 6 (p. 60) which shows the number of minutes that pulsation endures in various solutions consisting of one or all of the ingredients NaCl, KCl, CaCl₂, MgSO₄, and MgCl₂. In the experiments upon *Cassiopea*, *Lepas*, and *Salpa* Van t' Hoff's sea-water solution was employed. This consists of 100 NaCl + 2.2 KCl + 7.8 MgCl₂ + 3.8 MgSO₄ + 3CaCl₂, all of $\frac{5}{8}$ n concentration. In experiments upon the heart of the loggerhead turtle the proportions of the above-named salts were changed so as to be 0.7 per cent NaCl + 0.03 per cent KCl + 0.1 per cent MgCl₂ + 0.025 per cent CaCl₂. The various animals were placed in solutions containing one or all of these salts in the amounts and proportions stated above. Where + follows a number it means that pulsation occasionally lasts a few more minutes than is here recorded, and on the other hand, — following a number means that the pulsation does not usually last as long as is recorded.

An inspection of table 6 (p. 60) will show that pulsation in all of these forms (jellyfish, barnacle, tunicate, and reptile) is most powerfully stimulated by solutions composed of sodium chloride, potassium, and calcium, and that all are depressed by magnesium. Nevertheless sustained pulsation can only take place in a solution containing sodium, potassium, calcium, and *magnesium*, the last-named element being necessary to "tone down" and restrain the strong stimulation caused by the first three, thus giving a slower but indefinitely sustained pulsation. This important rôle of magnesium has hitherto

been unsuspected, and we see that Ringer's solutions, which consist of combinations of sodium, potassium, and calcium chlorides, are only stimulants, and must be partially inhibited and restrained by magnesium in order that they may sustain pulsation indefinitely.

In simple marine animals such as Medusæ, barnacles, and *Salpa* the optimum solution for pulsation is the sea-water itself, but in the higher terrestrial forms the proportions and amounts of the ingredients of the optimum solution have changed, although still composed of sodium chloride, potassium, calcium, and *magnesium*. In *Cassiopea*, *Lepas*, and *Salpa* it is the special rôle of calcium to assist the sodium chloride to overcome the anesthetic effect of magnesium, whereas potassium practically lacks this power.

A further inspection of table 6 shows that there are considerable differences in the effects of various elements upon different animals. For example, pulsation is sustained fairly well in *Cassiopea*, the heart of *Salpa democratica*, and the loggerhead turtle embryo by a pure NaCl solution, but this quickly stops the movement of the branchial arms of *Lepas*. Also, the addition of KCl to NaCl greatly improves the solution in its ability to sustain the pulsation of *Cassiopea*, whereas it has but little beneficial effect in the case of the arms of *Lepas*. Calcium, on the other hand, has but little power to sustain pulsation in connection with NaCl in *Cassiopea*, but in the case of the arms of *Lepas* it is very efficient. In *Cassiopea* pulsation ceases almost instantly in such non-ionizable solutions as urea, dextrose, and glycerin, but the heart of *Salpa democratica* will pulsate for a considerable time in these solutions, and the heart of the embryo loggerhead turtle pulsates as long in dextrose as it does in NaCl. These differences in the effects of the several salts upon pulsation in different animals are so considerable that we must be cautious of drawing general conclusions from the behavior of any one animal and applying them to related forms. For example, *Cassiopea* can not pulsate for 6 minutes in a solution resembling sea-water but simply lacking calcium, whereas another Scyphomedusa, *Linerges mercurius*, will pulsate for 45 minutes in the same solution. Both *Linerges* and *Cassiopea* are, however, restored to normal pulsation by the addition of calcium, and the difference in their behavior is one of degree, not of kind. The papers of physiologists abound in general conclusions concerning the action of "the vertebrate heart" when only the heart of the terrapin or the dog has been studied, and undoubtedly these sweeping conclusions are often misleading. For example, when the loggerhead turtle embryo is 11 to 14 days old its heart ceases to pulsate in less than 22 minutes in the

albumen of its own egg, but when it is 41 days old it pulsates from 3 to 7 hours in the albumen of its egg, which then sustains it better than can a Ringer's solution, or any solution I could devise. The albumen contains Na, K, Ca, and Mg.

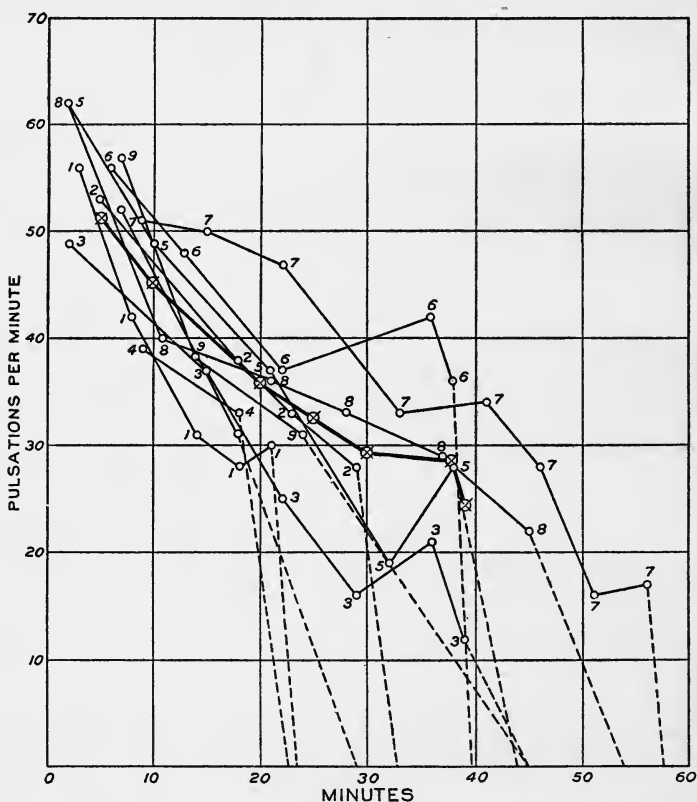

Fig. 34.—Showing the decline in rate and also the length of time that pulsation endured in the hearts of 10 loggerhead turtle embryos (11 to 14 days old) placed in 0.7 per cent NaCl+0.1 per cent MgCl₂. The heavy dark line shows the average condition, and the fine full lines show the behavior of individual embryos. The dotted lines cover periods from the last observation to the time when the heart ceased to beat.

The "all or none" principle in pulsation does not apply to the pulsation of the heart of the embryo loggerhead turtle, for the ventricle ceases first, then after a long time the auricles cease to pulsate, but the sinus still pulsates. Normally, as is well known, the heart-beat originates in the sinus; then after an interval the auricles respond, and finally the ventricle contracts. After the heart which has been removed from the body has ceased to pulsate, however, we may stim-

ulate the ventricle by an induction current, and after the current has been removed the heart may pulsate for several minutes in a reverse manner, each contraction originating at the stimulated place in the ventricle, then after a pause the auricles, and finally the sinus contracting.

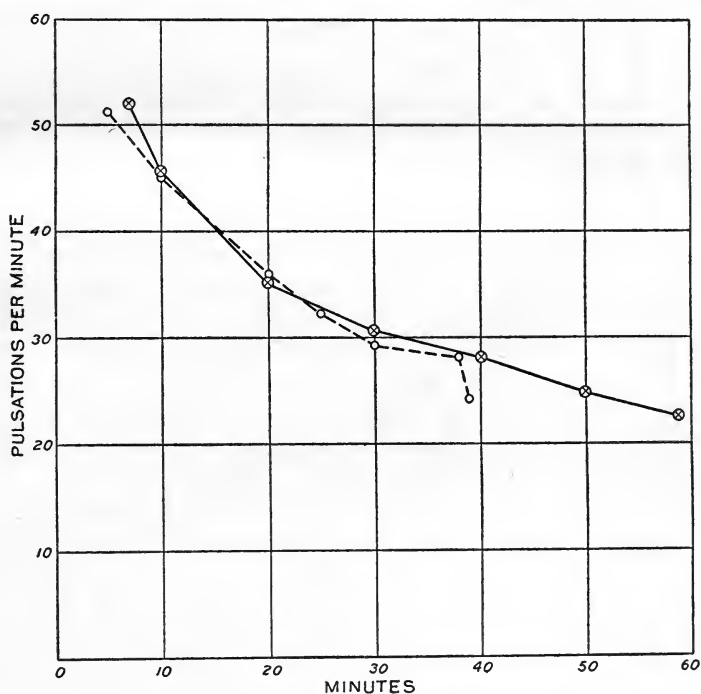

Fig. 35.—The full heavy line shows the average rate and duration of pulsation of the hearts of 10 loggerhead turtle embryos (11 to 14 days old) in 0.7 per cent NaCl. The dotted line shows the same things for the hearts of 10 embryos in 0.7 per cent NaCl+0.1 per cent MgCl₂. It appears that the NaCl+MgCl₂ does not affect the rate, but nevertheless it stops the heart sooner than does the pure NaCl solution.

The heart of the loggerhead turtle often revives temporarily immediately before it ceases to pulsate in solutions. This is seen in figures 34 and 36, which show the decrease in the rates of pulsation of the hearts of 20 loggerhead turtle embryos 11 to 14 days old. Ten of these (fig. 36) were placed in 0.7 per cent NaCl, and 10 others whose pulsation is shown in figure 34 were placed in 0.7 per cent NaCl+0.1 per cent MgCl₂. The MgCl₂ has no effect upon the rate, but it stops the heart sooner than does the pure NaCl. (See fig. 35.)

After the heart of the loggerhead turtle has ceased to pulsate in NaCl it may be revived temporarily by CaCl₂. KCl will also revive

it, but not so powerfully, and even *distilled water* or $MgCl_2$ will often give rise to a few final, weak pulsations. In other words, the heart responds to any osmotic change, be it beneficial or injurious. It is worthy of note, however, that if the heart ceases to beat in $NaCl + MgCl_2$ it is usually impossible to revive it, even by $CaCl_2$.

The heart of the loggerhead turtle embryo, 14 days old, pulsates more rapidly, and usually longer, in 0.7 per cent $NaCl + 0.03$ per cent KCl than it does in 0.7 per cent $NaCl$. Thus the addition of a small amount of KCl acts as a stimulus. Physiologists are in dispute concerning the action of potassium upon the "vertebrate heart," the general opinion being that potassium depresses the heart. The literature of this subject is reviewed by Carlson (1906, Amer. Journ. Physiology, vol. 16, p. 397). Much of the discrepancy in results arises from the sweeping conclusions which physiologists have drawn in applying to all vertebrates the results achieved from experiments upon a few forms. Moreover, in some papers experiments are conducted upon each salt separately, and the assumption is made that the effect of a mixture of these salts is merely the summation of their individual effects. Nothing could be more erroneous. For example, calcium alone never stimulates, but even inhibits pulsation in *Cassiopea*, but in connection with sodium and potassium chlorides it forms a most powerful stimulant.

In closing we will state that the heart of the embryo loggerhead turtle behaves quite differently from that of the animal after hatching, but we will leave the discussion of this and other points to a future paper, wherein we hope to treat of the general effects of different salts upon the hearts of various vertebrates and invertebrates.

In conclusion it may be said that rhythmical pulsation can be sustained only when an external stimulant is counteracted by an inhibitor, so that the pulsating organism is in a state bordering upon the threshold of stimulation. This allows the weakest internal stimuli to produce periodic contractions. Each contraction either produces a chemical change which periodically reduces the internal stimulus, or the tissue can not again respond to the ever-present, *constant* stimulus until after a period of rest.

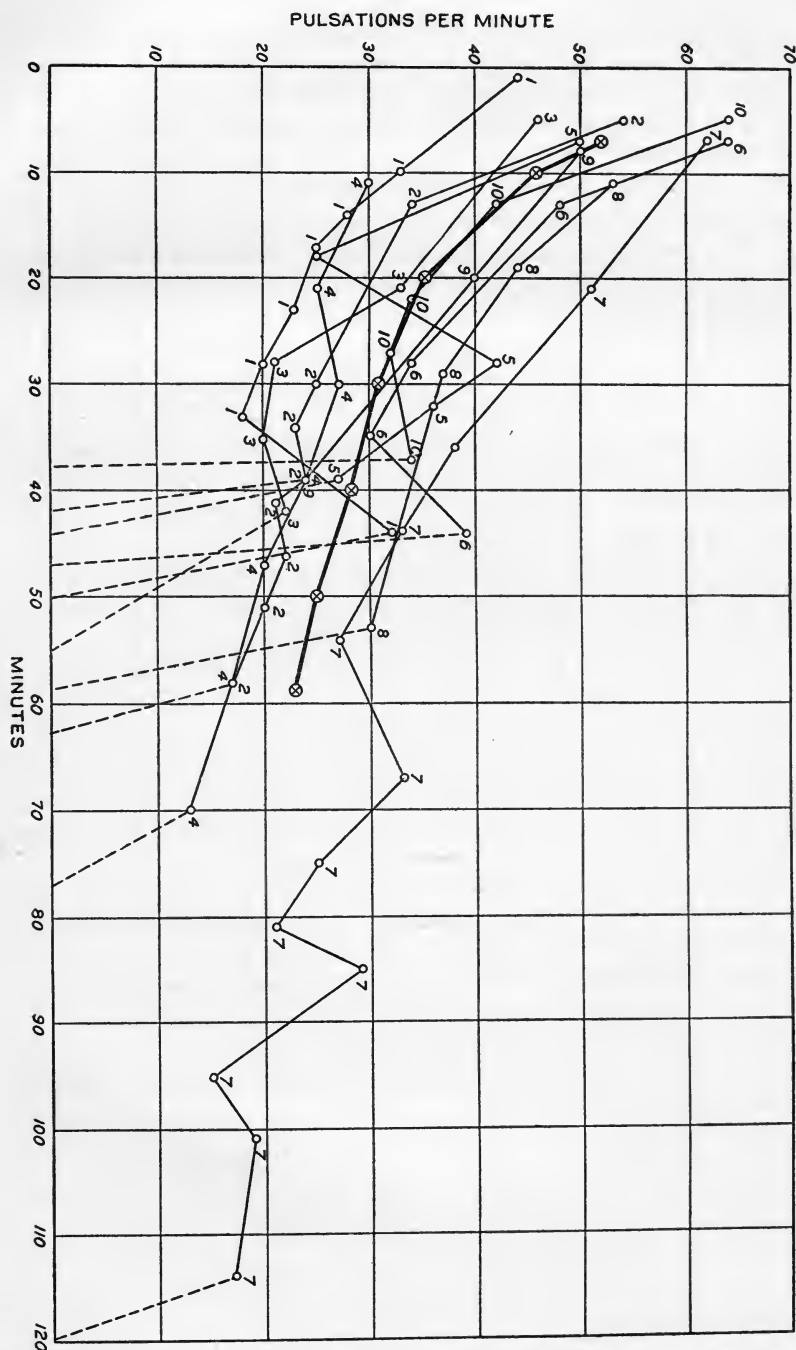

Fig. 36.—Showing the decline in rate and also the length of time that pulsation lasted in the hearts of 10 loggerhead turtle embryos (11 to 14 days old) placed in 0.7 per cent NaCl. The heavy line shows the average condition, and the fine unbroken lines show behavior of individual embryos numbered from 1 to 10. The dotted lines cover periods from the last observation to the time when the heart ceased to beat.

TABLE 6.—Showing the time that pulsation endures in various solutions containing Na, Ca, K, and Mg.

[*Cassiopea*, *Salpa*, and *Lepas* were placed in solutions containing some or all of the constituents of sea-water according to Van 't Hoff's formula: $\frac{1}{2}$ per cent NaCl + 2.2 per cent KCl + 7.8 per cent $MgSO_4$ + 3 per cent $CaCl_2$. The embryos of the loggerhead turtle were placed in solutions containing some or all of the constituents of the following: 0.7 per cent NaCl + 0.03 per cent KCl + 0.023 per cent $CaCl_2$ + 0.1 per cent $MgCl_2$.]

Composition of the solution.	<i>Cassiopea</i> , normal Medusae.	Branchial arms of <i>Lepas anatifera</i> .	Branchial arms of <i>Lepas fascicularis</i> .	Heart of <i>Salpa democrita</i> (duration of normal pulsation).	Heart of embryo loggerhead turtle (<i>T. caretta</i>) embryos in eggs 11 to 14 days after being laid.
NaCl.....	45— minutes.....	1 to 9 minutes.....	1 to 12— minutes.....	45 to 90— minutes..	37 $\frac{1}{2}$ to 109 $\frac{1}{2}$ minutes. Average of ten, 59.1 minutes.
NaCl+CaCl ₂	90— minutes.....	9 to 75 minutes.....	15 to 71 minutes.....	58 to 59 minutes.
NaCl+KCl.....	120+ minutes.....	8 to 32 minutes.....	3 to 22— minutes.....	50 to 82 minutes.
NaCl+CaCl ₂ +KCl.....	More than 180 minutes at more than double the normal rate.	180+ minutes. Still pulsating normally at the end of 2 hours.	180+ minutes. Still pulsating normally at the end of 2 hours.	180+ minutes. Still pulsating normally at the end of 2 hours.	60 to 80 $\frac{1}{2}$ minutes.
NaCl+MgSO ₄	7 $\frac{1}{2}$ to 10 minutes.....	4 to 9 minutes.....
NaCl+MgCl ₂	5 to 6— minutes.....	4— to 13 minutes.....	23 to 57 $\frac{1}{2}$ minutes. Average of ten, 39.3 minutes
NaCl+MgSO ₄ +MgCl ₂	3 $\frac{1}{2}$ to 6— minutes.....	39 to 41 $\frac{3}{4}$ minutes.
NaCl+MgCl ₂ +CaCl ₂	18— minutes.....	3 $\frac{1}{2}$ to 12— minutes..	45 to 90+ minutes...
NaCl+MgSO ₄ +MgCl ₂ +CaCl ₂	40— minutes.....	100 to 133 minutes.....	170 to 220 minutes...
NaCl+MgSO ₄ +MgCl ₂ +KCl.....	6— minutes.....	20— minutes.....	30— minutes.....	45— minutes.....
$\frac{1}{2}$ per cent NaCl + 2.2 per cent KCl + 7.8 per cent $MgSO_4$ + 3 per cent $CaCl_2$	Stops almost instantly.	2— to 3 minutes.....	12 minutes.....
$\frac{1}{2}$ per cent $MgSO_4$do.....
$\frac{1}{2}$ per cent KCl.....do.....	4 minutes.....
$\frac{1}{2}$ per cent CaCl ₂do.....	3 minutes.....
Urea isotonic with $\frac{1}{2}$ per cent NaCl.....do.....	8 minutes.....
Dextrose isotonic with $\frac{1}{2}$ per cent NaCl.....do.....	11 to 13 minutes.....	1 $\frac{1}{2}$ — to 4 minutes...	5 to 10 minutes.....	37 to 49 minutes. This dextrose solution was isotonic with 0.7 per cent NaCl.
Glycerin isotonic with $\frac{1}{2}$ per cent NaCl.....do.....	4 to 16 minutes.....	37 to 51 minutes.....	22— min. in embryos 11 to 14 days old, 180+ to 410+ min. in embryos 41 days old.
Clear albumen of loggerhead turtle egg.....	1 minute.....	14 to 21— minutes...

LITERATURE.

- BANCROFT, F. W. 1904. Note on the galvanotropic reaction of the Medusa *Polyorchis penicillata* A. Agassiz. Journ. Experimental Zool., vol. 1, No. 2, pp. 289-292.
- BANCROFT, F. W., and ESTERLY, C. O. 1903. A case of physiological polarization of the Ascidian heart. Univ. of California Publications, Zool., vol. 1, pp. 105-114.
- BETHE, A. 1903. Allgemeine Anatomie und Physiologie des Nervensystems. Leipzig, 487 pp.
- BIGELOW, R. P. 1892. *Cassiopea xamachana*, in Zool. Anzeiger. Bd. xv., p. 212. Also Mem. Boston Soc. Nat. Hist., 1900, vol. v, No. 6, pp. 191-236.
- CARLSON, A. J. 1904. The nervous origin of the heart-beat in *Limulus*, and the nervous nature of co-ordination or conduction in the heart. American Jour. Physiol., vol. XII, pp. 67-74. Also many papers in same journal, 1904-1906.
- 1906. On the chemical conditions for the heart activity, with special reference to the heart of *Limulus*. American Journal of Physiology, vol. XVI, No. 3, pp. 378-408.
- CUSHING, H. 1901. Concerning the poisonous effect of pure sodium chloride solutions upon the nerve-muscle preparation. Amer. Journ. Physiol., vol. VI, pp. 77-90.
- DITTMAR, W. 1884. The composition of ocean water. Reports of Voyage H. M. S. Challenger. Chemistry, vol. 1, p. 204.
- EIMER, TH. 1874. Über künstliche Theilbarkeit von *Aurelia aurita* und *Cyanea cappillate* in physiologische Individuen. Verhandl. physik—Medic. Gesellschaft, Würzburg. N. F. Bd. VI. Also, 1878; Die Medusen physiologisch und morphologisch auf ihr Nervensystem untersucht. Tübingen.
- FEWKES, J. W. 1882. *Cassiopea*. Bull. Mus. Comp. Zool. at Harvard Coll., vol. IX, p. 254. Also, 1883, *ibid.*, vol. XI, p. 80.
- GASKELL, W. H. 1900. The contraction of cardiac muscle, in Schäfer's Text-Book of Physiology, vol. II, pp. 169-227. Edinburgh and London.
- GREENE, C. W. 1898. On the relation of the inorganic salts of the blood to the automatic activity of a strip of ventricular muscle. American Journ. Physiol. vol. II, pp. 82-126.
- HARGITT, C. W. 1899. Experimental studies upon Hydromedusæ. Biol. Bulletin, Boston, vol. 1, No. 1, pp. 35-51. Also, 1904, Regeneration in *Rhizostoma pulmo*, Journal of Experimental Zoology, vol. 1, No. 1, pp. 73-94.
- HESSE, R. 1895. Über das Nervensystem und die Sinnesorgane von *Rhizostoma cavierei*. Zeitsch für Wissen. Zoologie, Bd. 60, pp. 411-556, Taf. 20-22.
- HOWELL, W. H. 1898. On the relation of the blood to the automaticity and sequence of the heart-beat. American Journ. Physiol., vol. II, pp. 47-81.
- 1901. An analysis of the influence of the sodium, potassium, and calcium salts of the blood on the automatic contractions of heart muscle. American Journ. Physiol., vol. VI, pp. 181-206.
- 1906. Text-Book of Physiology, pp. 477-530. Philadelphia and London.
- LINGLE, D. J. 1900. The action of certain ions on ventricular muscle. American Journal of Physiology, vol. IV, pp. 265-282.
- LOEB, J. 1899. Ueber Ionen welche rhythmische zuckungen der Skelettmuskeln hervorrufen. Festschrift für Fick. Braunschweig.
- 1900. On ion-proteid compounds and their rôle in the mechanics of life phenomena, etc. American Journ. Physiol., vol. III, pp. 327-338.
- LOEB, J. 1900. On the different effects of ions upon myogenic and neurogenic rhythmical contractions, and upon embryonic and muscular tissue. American Journ. Physiol., vol. III, pp. 383-396.
- 1905. Studies in General Physiology, 2 vols., 782 pp. Decennial Publications, University of Chicago.
- 1906. The stimulating and inhibitory effects of magnesium and calcium upon the rhythmical contractions of a jelly-fish (*Polyorchis*). Journ. of Biological Chemistry, New York, vol. 1, No. 6, pp. 427-436.
- MACALLUM, A. B. 1903. The inorganic composition of the Medusæ *Aurelia flavidula* and *Cyanea arctica*. Journal of Physiology, Cambridge, England, vol. 29, pp. 213-241.

- MATTHEWS, A. P. 1905. The toxic and antitoxic action of salts. Amer. Journ. Physiology, vol. 12, pp. 419-443.
- MAYER, A. G. 1906. Preliminary report upon the rhythmical pulsation of Scyphomedusæ. Year Book of the Carnegie Institution of Washington for 1905, No. 4, pp. 120-123.
- MELTZER, S. J., and AUER, J. 1905-'06. Physiological and pharmacological studies of magnesium salts. I. General anæsthesia by subcutaneous injections, American Journ. Physiol., vol. xiv, pp. 366-388. II. The toxicity of intravenous injections, etc. *Ibid.*, vol. xv, pp. 385-405. III. The narcotizing effect of magnesium salts upon nerve fibers. *Ibid.*, vol. xvi, pp. 233-251.
- MERUNOWICZ, J. 1875. Ueber die chemischen Bedingungen für die Enstelburg der Herzsclages. Math. Phys. Ber., Leipzig, Bd. 22, pp. 252-298.
- MURBACH, L. 1903. The static function in *Gonionemus*. American Journ. Physiol., vol. x, pp. 201-209.
- NAGEL, W. A. 1894. Experimentelle sinnesphysiologische Untersuchungen an Coelenteraten. Pflüger's Archiv für die gesammte Physiol., Bd. 57, pp. 495-552, Taf 7; also, Bd. 58, p. 308.
- PORTER, W. T. 1898. A new method for the study of the isolated mammalian heart. Amer. Journ. Physiology, vol. 1, pp. 511-518. Also 1897, Journal of Experimental Medicine, vol. 2, p. 391.
- RINGER, S. 1883. A further contribution regarding the influence of the different constituents of the blood on the contraction of the heart. Journal of Physiology, Cambridge, England, vol. iv, pp. 29-42, pl. 1.
- ROGERS, C. G. 1905. The effect of various salts upon the survival of the invertebrate heart. Journ. of Experimental Zool., vol. 11, No. 2, pp. 237-252, 1 plate.
- ROMANES, G. J. 1885. Jelly-fish, star-fish, and sea-urchins, being a research on primitive nervous systems. International Scientific Series, vol. XLIX, New York. (This is mainly a review of the author's previous papers in Nature, 1875, vol. 11, p. 29; Philosophical Trans. Royal Soc. London, vols. 166, 167, and 171, etc.)
- TULLBERG, T. 1892. Sur la conservation des invertébrés a l'état d'epanouissement. Archiv. Zool. Exper. et Gen., Tome 10, p. xi-xiv. Also Journal of the Royal Microscopical Society, ser. 2, vol. 12, 1892, p. 435.
- VON UEKKÜLL, J. 1901. Die Schwimmbewegungen von *Rhizostoma pulmo*, Mitth. Zool. Stat. Neapel, Bd. xiv, pp. 620-626.
- 1904. Die ersten Ursachen der Rythmus in der Tierreihe. Ergebnisse der Physiologie, Jahrg., 3, iv, Abt. 2, pp. 1-11.
- YERKES, R. M. 1902. A contribution to the physiology of the nervous system of *Gonionemus murbachii*. Part I, The sensory reaction of *Gonionemus*. American Journ. of Physiol., vol. vi, No. 6, pp. 434-449.

**THIS BOOK IS DUE ON THE LAST DATE
STAMPED BELOW**

**RENEWED BOOKS ARE SUBJECT TO IMMEDIATE
RECALL**

RETURN TO the circulation desk of any
University of California Library
or to the
NORTHERN REGIONAL LIBRARY FACILITY
Bldg. 400, Richmond Field Station
University of California
Richmond, CA 94804-4698

ALL BOOKS MAY BE RECALLED AFTER 7 DAYS

- 2-month loans may be renewed by calling (510) 642-6753
- 1-year loans may be recharged by bringing books to NRLF
- Renewals and recharges may be made 4 days prior to due date.

DUE AS STAMPED BELOW

NOV 24 1997

RETURNED

NOV 14 1997

Santa Cruz

N^o 474296

Mayer, A.G.
Rhythmical pulsation
in Scyphomedusae.

QL377

S4

M4

LIBRARY
UNIVERSITY OF CALIFORNIA
DAVIS

