

U.S. Army  
Coast. Eng. Res. C  
MP 11-75  
(AD-A019 833)

# Sand Level Changes on Torrey Pines Beach, California

by  
Charles E. Nordstrom and Douglas L. Inman

MISCELLANEOUS PAPER NO. 11-75  
DECEMBER 1975



Approved for public release;  
distribution unlimited.

Prepared for  
U.S. ARMY, CORPS OF ENGINEERS  
COASTAL ENGINEERING  
RESEARCH CENTER

Kingman Building  
Fort Belvoir, Va. 22060

GB  
450  
.U3  
no. 11-75

Reprint or republication of any of this material shall give appropriate credit to the U.S. Army Coastal Engineering Research Center.

Limited free distribution within the United States of single copies of this publication has been made by this Center. Additional copies are available from:

*National Technical Information Service  
ATTN: Operations Division  
5285 Port Royal Road  
Springfield, Virginia 22151*

Contents of this report are not to be used for advertising, publication, or promotional purposes. Citation of trade names does not constitute an official endorsement or approval of the use of such commercial products.

The findings in this report are not to be construed as an official Department of the Army position unless so designated by other authorized documents.



REPORT DOCUMENTATION PAGE		READ INSTRUCTIONS BEFORE COMPLETING FORM
1. REPORT NUMBER MP 11-75	2. GOVT ACCESSION NO.	3. RECIPIENT'S CATALOG NUMBER
4. TITLE (and Subtitle) SAND LEVEL CHANGES ON TORREY PINES BEACH, CALIFORNIA	5. TYPE OF REPORT & PERIOD COVERED Miscellaneous Paper	
	6. PERFORMING ORG. REPORT NUMBER	
7. AUTHOR(s) Charles E. Nordstrom Douglas L. Inman	8. CONTRACT OR GRANT NUMBER(s) DACW72-72-C-0020	
9. PERFORMING ORGANIZATION NAME AND ADDRESS Scripps Institution of Oceanography La Jolla, California 92037	10. PROGRAM ELEMENT, PROJECT, TASK AREA & WORK UNIT NUMBERS D31194	
11. CONTROLLING OFFICE NAME AND ADDRESS Department of the Army Coastal Engineering Research Center (CERRE-CP) Kingman Building, Fort Belvoir, Virginia 22060	12. REPORT DATE December 1975	
	13. NUMBER OF PAGES 166	
14. MONITORING AGENCY NAME & ADDRESS (If different from Controlling Office)	15. SECURITY CLASS. (of this report) UNCLASSIFIED	
	15a. DECLASSIFICATION/DOWNGRADING SCHEDULE	
16. DISTRIBUTION STATEMENT (of this Report) Approved for public release; distribution unlimited.		
17. DISTRIBUTION STATEMENT (of the abstract entered in Block 20, if different from Report)		
18. SUPPLEMENTARY NOTES		
19. KEY WORDS (Continue on reverse side if necessary and identify by block number) Torrey Pines Beach, California Beach profile measurement Seasonal sand levels Visual wave observations Recording depth gage		
20. ABSTRACT (Continue on reverse side if necessary and identify by block number) Three parallel range lines were established along a straight beach at Torrey Pines, California, and were surveyed at monthly intervals during June 1972 to May 1974. Offshore sand level changes were measured using reference rods placed in the bottom at selected stations on each range line.  Beach profile measurements indicate that the beach underwent seasonal changes in configuration which are related to changes in the wave regime.		

## 20. Abstract (Continued).

During the summer months the beach profile progressively changed with the seaward progradation of the berm crest by sand accretion. This change was caused by onshore transport of sand from immediately offshore depths of less than -20 feet (-6.1 meters) relative to MSL.

The transition from the summer to the winter beach profile was abrupt with the coincident occurrence of high waves and tides. Periods of high waves during high tides resulted in wave swash overtopping the berm crest and quickly eroding the beach. The rapid shoreward retreat of the berm crest caused by the offshore transport of sand was accompanied by a corresponding deposition of sand offshore at depths less than -30 feet (-9 meters) relative to MSL.

## PREFACE

This report is published to provide coastal engineers with profile and sediment data collected during a 23-month survey of beach and offshore sand level changes along a straight beach at Torrey Pines, California. The work was carried out under the coastal processes program of the U.S. Army Coastal Engineering Research Center (CERC).

This report is published, with only minor editing, as received from the contractor; results and conclusions are those of the authors and are not necessarily accepted by CERC or the Corps of Engineers.

The report was prepared by Dr. Douglas L. Inman, Professor of Oceanography, and Charles E. Nordstrom, Associate Specialist in Marine Geology, Scripps Institution of Oceanography, La Jolla, California, under CERC Contract No. DACW72-72-C-0020. Data obtained under the contract was used to augment and help evaluate similar information in the CERC Beach Evaluation Program. The authors acknowledge the assistance of Michael Kirk and Earl Murray in the collection and reduction of field data.

Dr. Craig H. Everts, Oceanographer, was the CERC technical monitor for this contract under the supervision of Dr. C.J. Galvin, Chief, Coastal Processes Branch, Research Division.

Comments on this publication are invited.

Approved for publication in accordance with Public Law 166, 79th Congress, approved 31 July 1945, as supplemented by Public Law 172, 88th Congress, approved 7 November 1963.

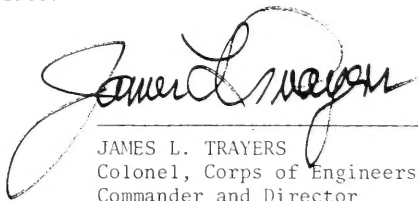

JAMES L. TRAYERS  
Colonel, Corps of Engineers  
Commander and Director

	Page
I INTRODUCTION . . . . .	7
1. Objective of the Study . . . . .	7
2. Previous Work . . . . .	7
II TORREY PINES BEACH STUDY AREA . . . . .	8
III FIELD PROCEDURE . . . . .	8
1. Bench Marks . . . . .	8
2. Profile Surveys . . . . .	12
3. Reference Rods . . . . .	14
4. Recording Depth Gage . . . . .	15
5. Visual Wave Observations . . . . .	18
IV DATA REDUCTION PROCEDURE . . . . .	18
V BEACH PROFILE CHANGES . . . . .	19
1. Seasonal Changes June 1972 - October 1972 . . . . .	20
2. Seasonal Changes November 1972 - April 1973 . . . . .	20
3. Seasonal Changes April 1973 - October 1973 . . . . .	27
4. Seasonal Changes November 1973 - April 1974 . . . . .	27
5. Storm Associated Changes . . . . .	31
VI CONCLUSIONS . . . . .	32
LITERATURE CITED . . . . .	34
APPENDIX	
A DESCRIPTION OF RANGE LINES AND BENCH MARKS, TORREY PINES BEACH, CALIFORNIA . . . . .	35
B DISTANCE-ELEVATION DATA FOR BEACH PROFILES SURVEYED AT TORREY PINES BEACH, CALIFORNIA . . . . .	44
C DESIGN AND DEVELOPMENT OF THE RECORDING DEPTH GAGE . . . . .	97
D VISUAL WAVE OBSERVATIONS FROM SOUTH RANGE, TORREY PINES BEACH, CALIFORNIA . . . . .	105
E COMPARISON OF PRESSURE SENSOR ARRAY AND VISUAL OBSERVATIONS OF WAVES AT TORREY PINES BEACH, CALIFORNIA . . . . .	130
F PLOTTED BEACH PROFILES . . . . .	145
G DESCRIPTION OF THE COMPUTER PROGRAM FOR PLOTTING BEACH PROFILES . . . . .	158
H SEDIMENT ANALYSIS DATA . . . . .	165

CONTENTS

FIGURES

	Page
Frontispiece—Aerial photograph of Torrey Pines Beach study area . . .	6
1 Location map . . . . .	9
2 Location of range lines, bench marks, and reference rod stations for beach profile measurements . . . . .	11
3 Survey procedure . . . . .	13
4 Comparison of reference rod measurements and acoustic soundings, South Range . . . . .	16
5 Schematic diagram of recording depth gage . . . . .	17
6a Berm crest and offshore sand level changes on South Range, June 1972 to June 1974 . . . . .	21
6b Berm crest and offshore sand level changes on North Range, June 1972 to June 1974 . . . . .	22
6c Berm crest and offshore sand level changes on Indian Canyon Range, June 1972 to June 1974 . . . . .	23
7 Comparison of October and November 1972 beach profiles . . . . .	24
8 Comparison of beach profiles measured at North Range, 23 October 1972 . . . . .	26
9 Comparison of beach profiles measured at North Range, 25 October 1973 . . . . .	28
10 Onshore movement of sand at North Range . . . . .	29

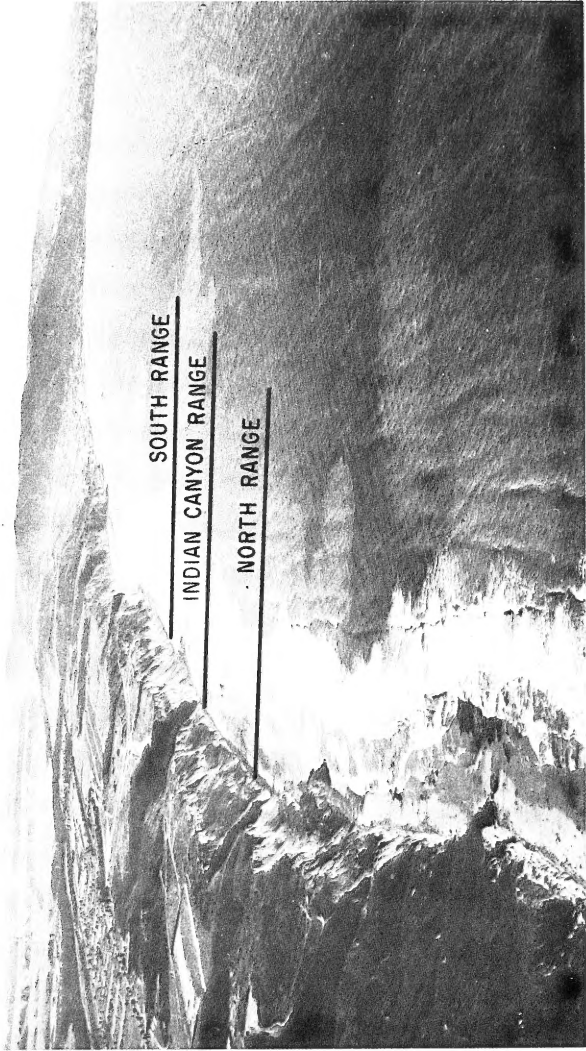

Frontispiece. Aerial photograph of Torrey Pines Beach study area.



# SAND LEVEL CHANGES ON TORREY PINES BEACH, CALIFORNIA

by

*Charles E. Nordstrom and Douglas L. Inman*

## I. INTRODUCTION

### 1. Objective of the Study.

The principal objective of this study was to measure beach profiles along a straight beach with uncomplicated offshore bathymetry that is exposed to ocean waves from all offshore directions. Emphasis in this study was placed upon the accurate measurement of beach profiles in order to determine changes in profile configuration caused by wave action. Profiles were measured from the beach backshore seaward to a depth of about 60 feet (18 m) at monthly intervals for a period of 23 months. Additional measurements were made following storms and periods of high waves in order to document the extent of profile modification associated with these periodic events. Daily visual observations and measurements by pressure sensors provided a record of the waves incident to the beach during the duration of the study. Comparison of the profiles from month to month and seasonally was made to determine the erosional and depositional parts of the profile and the volumes of sand involved in onshore-offshore transport.

### 2. Previous Work.

Many studies have been made of the changes in beach profiles under waves; however, most field data are difficult to interpret in terms of seasonal changes in configuration and onshore-offshore sand transport because of the inaccuracy in the measurements. Most beach profiles are only measured from the backshore seaward into the surf zone, usually ending near the mean sea level datum. This type of data is useful for documenting changes in the beach foreshore and sand levels on the subaerial beach but does not document the onshore-offshore sand transport. In order to adequately measure the actual changes in profile configuration and onshore-offshore transport, the beach profile must be accurately measured to the seaward limit of significant sand movement.

Studies of sand level changes on southern California beaches have been made by Shepard (1950), Shepard and Inman (1951), Inman (1953), Brunn (1954), and Inman and Rusnak (1956). However, of these previous studies, only Inman and Rusnak (1956) made accurate measurements of sand level changes over the offshore segment of the profile. The Inman

and Rusnak study was made on a shelf area between two branches of La Jolla Submarine Canyon so that sand movements were influenced by the refraction of waves over the complex nearshore bathymetry. This study of beach profile changes and onshore-offshore sand transport is similar to that of Inman and Rusnak (1956) but applied to a straight beach with uncomplicated offshore bathymetry.

## II. TORREY PINES BEACH STUDY AREA

The site selected for this study was a segment of Torrey Pines Beach in San Diego County, California. The study area consisted of a straight, fine-grained sand beach located approximately 2 miles north of Scripps Institution of Oceanography. A 1.6-mile (3.0 km) segment of this beach that has gently sloping offshore bathymetry and is terminated shoreward by a 300-foot (91 meters) high sea cliff was used for the beach profile measurements (Figure 1). This beach satisfied the basic requirements for a straight beach with uncomplicated offshore bathymetry that is exposed to waves from all offshore quadrants. In addition, the site has the advantage of being readily accessible on land by a private road and from sea by use of boat launching facilities at Scripps Institution.

Torrey Pines Beach is at the southern end of a littoral cell that extends northward 51 miles (82 km) to Dana Point. Sand is supplied to this cell by streams entering the ocean along this stretch of coastline and from minor sea cliff erosion (State of California, 1969). Waves cause a net longshore transport of sand to the south through the littoral cell to Scripps Submarine Canyon which is located 1.5 miles (2.8 km) south of the study site. Chamberlain (1960) and State of California (1969) have estimated the net littoral transport in the vicinity of Torrey Pines Beach at about  $2.6 \times 10^5 \text{ yd}^3/\text{yr}$  ( $2 \times 10^5 \text{ m}^3/\text{yr}$ ). Once in Scripps Canyon, the sand is periodically transported by strong currents from the nearshore zone through the canyon into deep water.

The study site beach segment undergoes typical seasonal changes in configuration due to changes in wave climate. During summer wave conditions, the beach has a 100- to 200-foot-wide (30 to 60 m) backshore, a relatively steep upper foreshore, and a pronounced berm. Winter storm waves overtop the summer berm and erode the backshore, thus reducing the width of the exposed beach. Winter beach profile configuration is typified by a gently sloping beach foreshore that in places extends shoreward to the toe of the sea cliff. Accurate measurement of these seasonal changes in beach profile configuration was the principal objective of this study.

## III. FIELD PROCEDURE

### 1. Bench Marks.

The beach at the study site is oriented true north-south so that three range lines were established normal to the beach in a true east-

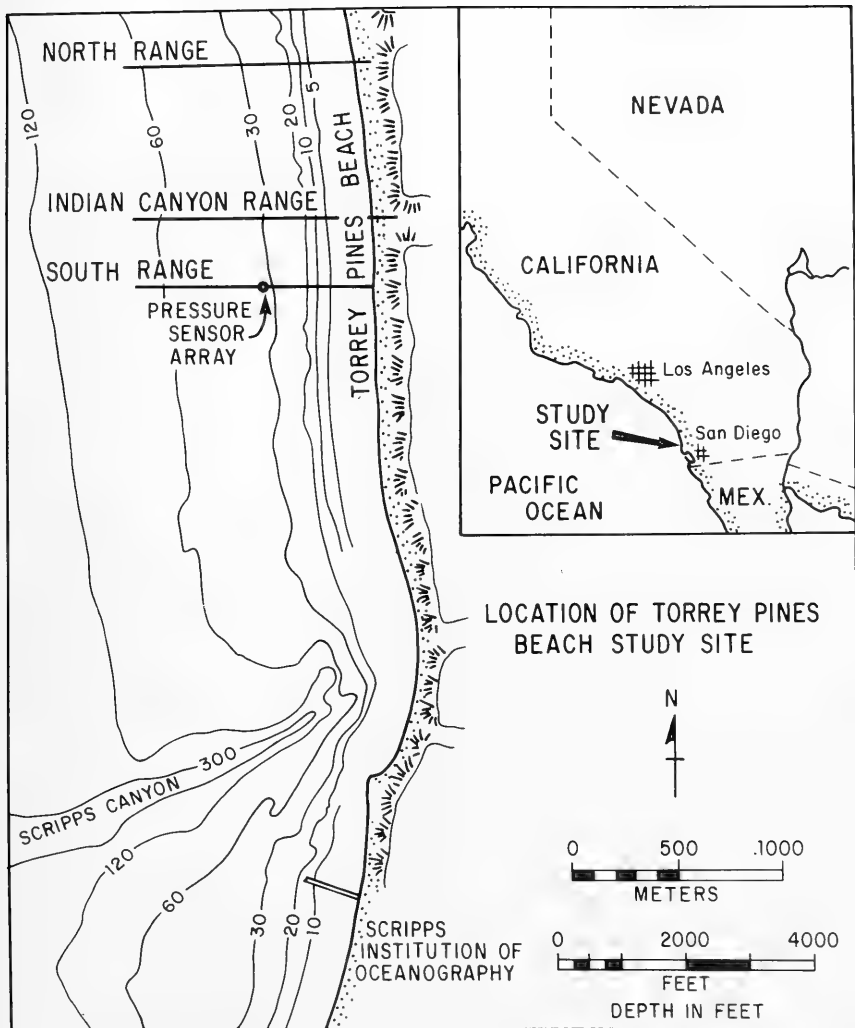

Figure 1. Location map.

west direction. A prominent canyon (Indian Canyon) cuts through the cliffs to the beach at the study site so the central range line was located near the mouth of the canyon for geographic reference. Another range line was located 1,135 feet (346 meters) south of the Indian Canyon range line, and the third range line was located 2,200 feet (670 meters) north of the Indian Canyon range line. These range lines were named South Range, Indian Canyon Range, and North Range to designate their geographic position relative to Indian Canyon (Figure 2).

A level line survey was made from an established U. S. Coast and Geodetic Survey bench mark to South Range along the top of the sea cliff. This survey was made using a transit, rod and tape with calibration marks of  $\pm 0.01$  foot ( $\pm 0.3$  cm) on horizontal and vertical distances. The permanent position and elevation of two points were established on the flat terrace above the cliff on South Range. These points are:

- a. A point located at the base of the seaward monument of the U.S. Navy measured nautical mile course.
- b. A point located by a pipe driven into the ground within a few feet of the cliff edge.

The elevation of the bench mark on the beach at South Range was determined by using a trigonometric solution. The vertical angle from the established point at the top of the cliff and a point on the beach was accurately measured with a transit. Then the "thin air" distance between the point at the top and bottom of the cliff was measured with a Hewlett-Packard 3800A Distance Meter. These two measurements allowed the calculation of the vertical distance between the two points to within a fraction of a foot.

The exact location and elevation of the bench marks for Indian Canyon and North Ranges were established by making a level line survey along the beach from the South Range bench mark. The accuracy of the elevation between the bench marks for the three range lines is about 0.01 foot (0.3 cm). Appendix A has a description of the bench marks established on Torrey Pines Beach and the notes from the bench mark surveys.

Each range line is physically located by two points on the range at beach level. These points are marked by 1/2-inch-diameter stainless steel pipe 3 feet long driven into the ground and cemented in place. The seaward pipe is capped with a brass plug that is labeled as S10 I, S10 II, and S10 III for South Range, Indian Canyon Range, and North Range, respectively. The landward point on each range line is marked by an open 1/2-inch-diameter stainless steel pipe set back from the seaward point. For protection from vandalism and natural erosion, the bench mark pipes were set at the landward edge of the beach and up on the toe of the sea cliff. The pipes were pounded into the present ground surface to reduce their conspicuousness and increase their stability. All of the original

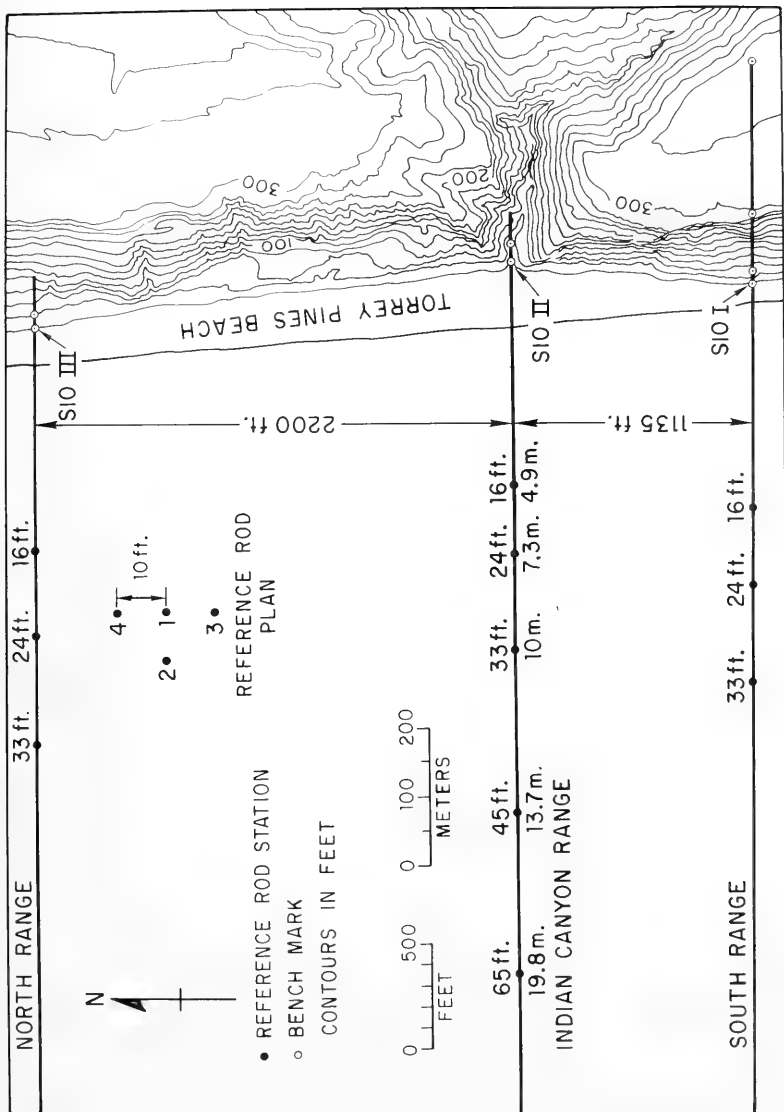

Figure 2. Location of range lines, bench marks, and reference rod stations for beach profile measurements on Torrey Pines Beach.

bench mark monuments placed for this study remain serviceable and did not require any repair during the term of the study.

## 2. Profile Surveys.

Beach profile surveys were accomplished in two parts on the same day: 1) the backshore and upper foreshore were measured from the bench mark out to wading depths, on the low tide; and 2) the offshore part of the profile was measured with a fathometer on a boat seaward from the breakers, on the high tide (Figure 3). By doing the monthly surveys on the date of maximum spring tidal range during daylight hours, overlap of the two parts of the survey was usually achieved. High waves and winds complicated the survey operation and introduced errors into the fathometer survey of the offshore profile segment.

The land survey of the backshore and foreshore was done using a transit, surveyor's rod, and tape. Elevations were measured to 0.01 foot (0.3 cm) and distances to 0.1 foot (3 cm). Alinement along the range line was achieved by using flags to mark the two bench marks on the range. Rod stations were measured at 10-foot (3 meters) intervals seaward of the bench mark except where pronounced changes in the slope occur. Measurements were made out into the water by the tapeman paying out the tape in 10-foot (3 meters) increments from a fixed point at the water edge. The land survey was terminated when the water became too deep for the rodman to wade or the breaking waves made it impossible to plumb the rod.

The offshore part of the survey was done with a Raytheon Model DE719 survey fathometer used from a 16-foot boat. This is a portable survey fathometer that allows for calibration to specific oceanographic conditions of seawater temperature and salinity and is an ideal instrument for the survey depths of this study.

However, use of a survey fathometer for measuring beach profiles on the ocean involves additional errors inherent in reducing the fathometer data to an actual bottom profile. These errors are due to the effect of waves, tide, relation of transducer to water surface, etc., involved in correcting the raw fathometer readings to the profile soundings. Saville and Caldwell (1953) evaluated the accumulated acoustic sounding error involved in measuring beach profiles with a fathometer by making repeated soundings of a single profile over a short period of time, and comparing them to lead line soundings. Their results show that the probable error in this survey method is less than 0.5 foot (15 cm). Thus, it is thought with proper calibration and suitable care in reducing the data, that an accuracy of  $\pm 1$  foot ( $\pm 30$  cm) was possible in using a fathometer for the offshore profile measurements.

Positioning of the boat during the offshore part of the profile survey was performed by a range and horizontal sextant angle system similar to that employed by Inman and Rusnak (1956). Each range line

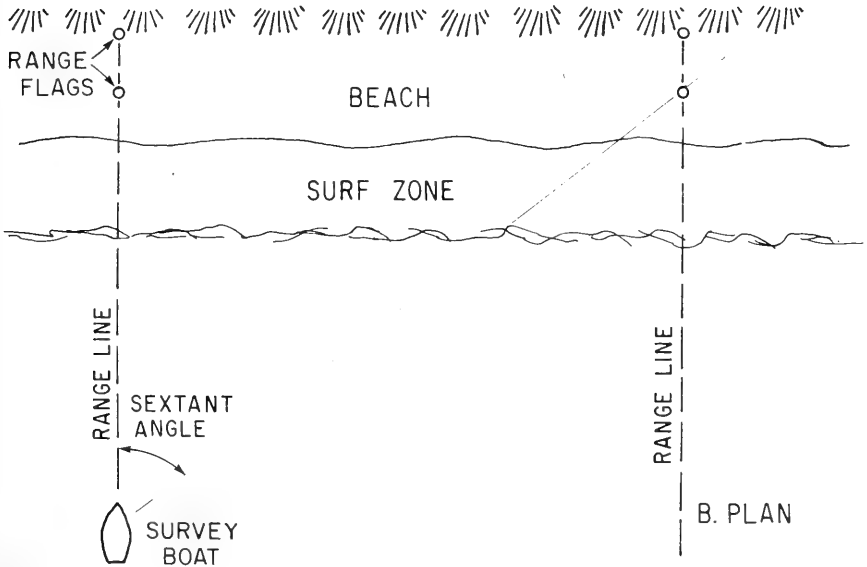
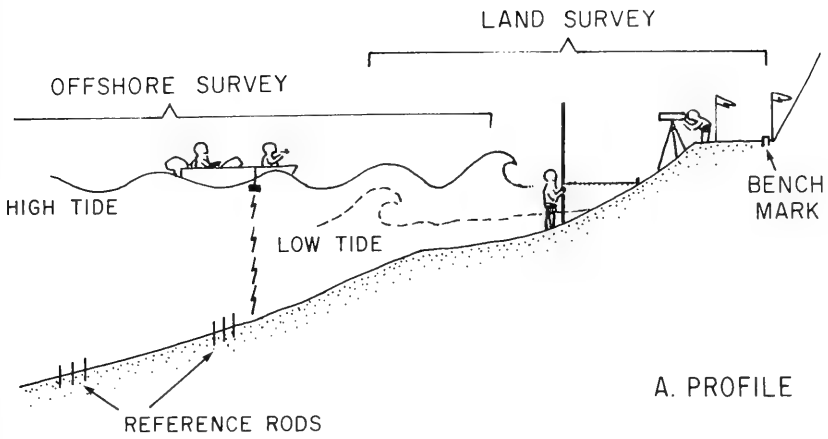

Figure 3. Survey procedure.

is marked by two flags for alinement on the range and horizontal sextant angles were determined between the range and the marker flag on an adjacent range (Figure 3). Sextant angles were measured every 20 seconds as the boat proceeded toward shore and were correlated with time marks on the fathometer record. The distances along the range line were then calculated from the angles and plotted with the appropriate sounding.

### 3. Reference Rods.

The offshore profile measurements made with a fathometer were not accurate enough to detect small changes in sand level on the shelf. Thus, in order to monitor these changes along the profile, reference rods were placed on the bottom on each range using the procedure of Inman and Rusnak (1956). Arrays of reference rods were placed at depths of -16, -24, and -33 feet (-4.9, -7.3, and -10 meters) on each range. Additional reference rod arrays were placed at depths of -45 and -65 feet (-13.7 and -19.8 meters) on Indian Canyon Range (Figure 2). Each reference rod array consists of four 3/8-inch brass rods that were 4 feet long and driven into the sand bottom so that 1 foot of the rod was left exposed. The rods were placed in a "T" pattern with 3 rods arranged in a line parallel to shore and 1 rod offshore from the center rod of the line. Figure 2 shows the spacing of the reference rods and their number designation in the array. Some of the shallow reference rod arrays were changed from a "T" to a "+" pattern with the addition of a rod with 2 feet (61 cm) of exposed length placed 10 feet (3 meters) onshore from the center rod of the line. This longer rod was added because sand deposition at the shallow reference rod stations buried the shorter rods in winter. Absolute elevations of the reference rods were determined using a sounding line at the time of installation. A diver held the line on the bottom while an observer in a boat immediately above determined the depth of water. This depth was then corrected to the datum of mean sea level using the tide gage at the end of the Scripps Pier. Each depth measurement was estimated to the nearest 0.1 foot (3 cm), using a graduated sounding line. The mean of five measurements was then taken as the depth of the bottom at the site of the rod. Mathematically these measurements usually had a standard deviation of about 0.1 foot (3 cm). However, there are operator biases and wire angle errors in the soundings and additional errors in tide gage corrections that lead us to believe that the probable accuracy of the absolute elevation is about 0.3 foot (9 cm).

The reference rods were measured with each monthly survey of the beach profiles. Measurements were made by divers who located the station by range and horizontal sextant angle, marked it with a buoy, and found the rods by underwater search from the buoy position. Positioning on the surface was usually accurate enough to place the buoy anchor within 20 feet (6.1 meters) of the array edge. Often the buoy anchor was placed within the margins of the array so that no underwater search was required. The exposed length of each rod was marked on a piece of plastic and measured at the surface. The reference rod elevations in



Appendix B are the average of four-rod measurements at each station, each measured to the nearest 0.01 foot (0.3 cm) giving a probable error of about 0.01 foot (0.3 cm) for the station. These measurements are relative to the top of the rod and are more accurate than the assigned station elevation. The 0.01 foot (0.3 cm) accuracy is used in computation of sand level changes as it is always referenced to the "top of the rod" and not a change in absolute elevation.

Measurements and soundings taken at each reference rod station were used as absolute reference points for the fathometer data obtained from the offshore surveys. Figure 4 shows a comparison of the reference rod measurements and acoustic soundings made at the 33-foot (10 meters) station on South Range. As can be seen, the acoustic sounding from the offshore surveys indicate depth variations of  $\pm 1$  foot ( $\pm 30$  cm) relative to the lead line sounding depth of 33 feet (10 meters). These differences are related to errors in the survey procedure since the reference rod measurements indicate little or no change in actual sand level. Similar differences were observed by Inman and Rusnak (1956, Figure 9).

#### 4. Recording Depth Gage .

The beach profile surveys and reference rod data were supplemented with soundings made with the recording depth gage that was developed for this study. The instrument consists of a pressure sensor, logic circuitry, and a three-digit panel meter. An absolute pressure transducer with a sensing range of about 13-30 psia was used in the instrument. This sensor is capable of sensing water level changes of  $\pm 0.08$  feet (24 cm) in water up to -58 feet (-17.7 meters) in depth. Output from the sensor was interfaced through an amplifier-low pass filter and a variable gain amplifier to a digital display (Figure 5). The intent of instrument design is to use an accurate pressure sensor to measure the water level and then filter out the high-frequency oscillation caused by waves and only read the mean depth. The low-pass filter used in the instrument has a time constant of about 1 minute, so that only low-frequency water level changes affect the measurements.

The physical assembly of the instrument is such that the pressure sensor and logic circuitry are one package called the sensing package; and the recording panel meter and its power supply are another package called the recording package. The sensing package is mounted on a triangular-shaped metal plate that assured proper orientation of the pressure sensor to the bottom and prevented scouring into the sand bottom. This package is lowered to the bottom at a station for the 5-minute recording period with a surface float to mark its location for retrieval. The measurement of water depth made by the pressure sensor is averaged and retained by the logic circuitry for display. At the end of the measurement period the sensing package is retrieved and once at the surface the recording package is connected to its output for display of the measured depth. Once the measurement is recorded on a data sheet, the instrument is cleared with a reset switch to prepare it for the next measurement.

# TORREY PINES BEACH SOUTH RANGE — 33 FT. STATION

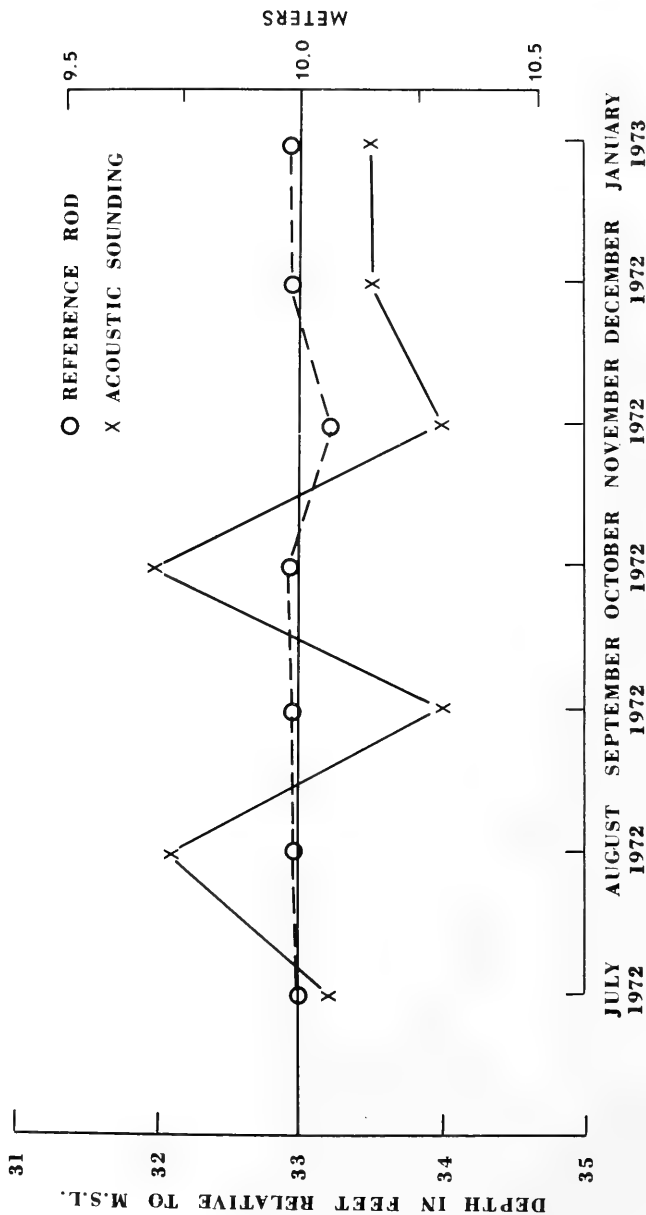

Figure 4. Comparison of reference rod measurements and acoustic soundings made with a fathometer at a depth of 33 feet on South Range. Variations in the acoustic soundings reflect errors in the fathometer data related to the presence of waves and positioning of boat.

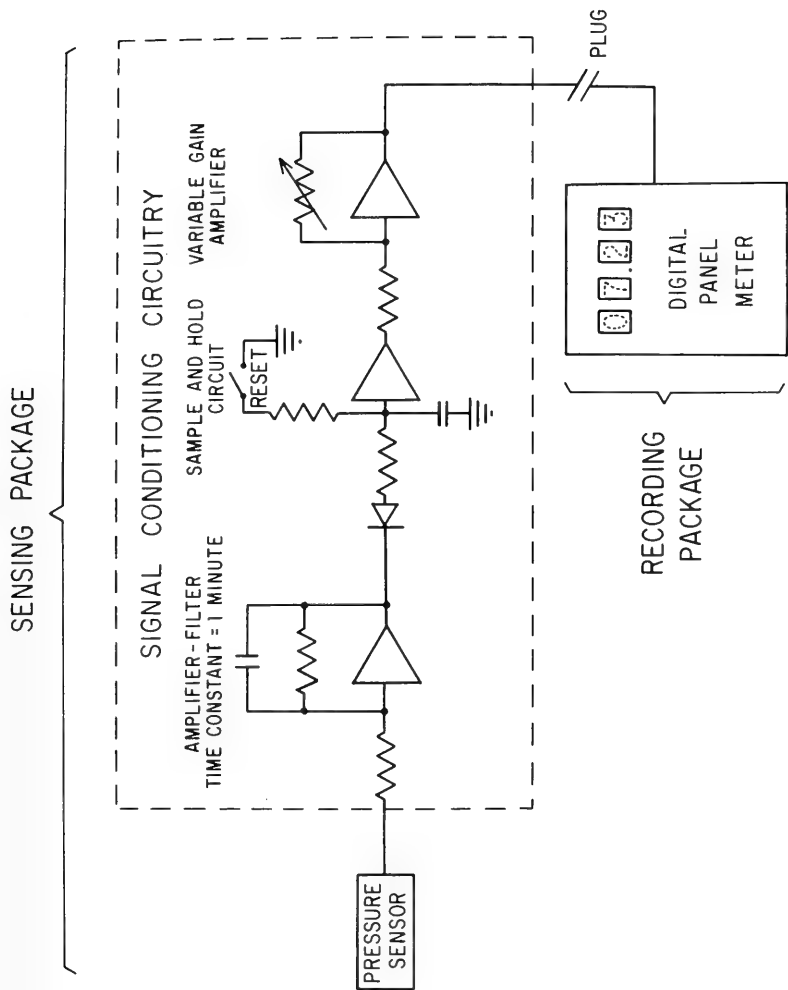

Figure 5. Schematic diagram of recording depth gage showing the basic components of the signal conditioning circuitry.

The recording depth gage is intended to supply beach profile data from that segment of the profile near the surf zone where it is hazardous to make a fathometer survey or to anchor the boat for a lead line sounding. Deployment of the depth gage involved traversing the range line quickly to a station very near the break point and then dropping the sensing package as a sextant angle is shot at the station. After the recording period the sensing package is quickly recovered by the boat and the measurement is read. The instrument was employed in field usage a number of times during its development, and was found to yield measurements that were inconsistent with independent lead line measurements. Each field trial brought further modification of the instrument design. As a result, all field information obtained from the instrument during this study has been used for calibration purposes and is reported in Appendix C.

#### 5. Visual Wave Observations.

Wave energy incident to the study-site beach was documented by two methods: (a) visual wave observations made daily on weekdays at South Range; and (b) wave measurements made with a line array of pressure sensors located at a depth of -33 feet (-10 meters) on South Range. Visual observations were made using the same procedure as developed for the CERC Beach Evaluation Program. Wave and surf observations made at the beach level at South Range included an estimate of the height of the highest one-third of the waves, the average period of 10 consecutive waves, and the breaker type.

To supplement the visual wave observations at the beach level, additional wave observations were made from a fixed point at the top of a 300-foot (91 meters) high sea cliff at South Range. From this point a visual estimate of the breaker angle and a photograph of the wave conditions were made. The photograph was always oriented so that its bottom margin was aligned with the beach in order to accurately illustrate the breaker angle. Appendix D is a tabulation of the daily visual wave observations from June 1972 through May 1974.

Wave measurements from the pressure sensor array are described in a separate report to CERC including the conclusions of that study. Appendix E is a comparison between the visual observations and the pressure sensor array measurements for those dates with synoptic data. This comparison indicates that the visual observations and pressure sensor measurements are in general agreement for wave direction when wave refraction from the sensor array to the beach is taken into account.

#### IV. DATA REDUCTION PROCEDURE

All measurements of beach profiles for this study were determined from the permanent bench marks established on the beach. Distances were referenced seaward from the bench mark and elevations were referenced to mean sea level (MSL). The mean lower low water (MLLW) datum is -2.7 feet

(-75.5 cm) relative to MSL at the study site so that all elevations can be cross-referenced to MLLW if necessary.

At the time of the actual surveys data were recorded on field data sheets designed to accommodate the measurements acquired from the land and offshore surveys. The land survey data consisted of distances measured from the bench mark and rod readings measured with a transit. Data reduction for the land survey simply involved calculating the elevations relative to MSL datum. In addition, the fathometer data were compared to lead line and depth gage soundings and the reference rod measurements to verify their accuracy at specific stations on each range line.

The corrected profile data were then recorded on standard BEP scanning forms (CERC Form No. 60, 4 August 69 and CERC Form No. 83-71, 26 May 71) for transmittal to CERC. At CERC these data were then plotted for their files using a line printer. The distance-elevation pairs for each survey point are given in Appendix B.

Plotting of the profile data for study at Scripps was done with the use of a Burroughs 6700 computer and its 11-inch x-y plotter. A short ALGOL computer program was devised to produce a computer-plotted profile from the reduced survey data. These data were punched on IBM cards for computer input. The program output is an ink plot of the beach profile at a scale of 1 inch = 10 feet for elevation and 1 inch = 100 feet for distance on one set of axes with an equivalent scale in the metric system on the other axes. Plotted beach profiles for the surveys are compiled in Appendix F.

Appendix G gives a description and listing of the beach profile plotting computer program. Use of the computer to plot the beach profiles was found to accelerate the process of making comparisons between different surveys since any two sets of survey data can quickly be processed by the computer. Also, the IBM card files of the surveys have been found to be a good reference library for making additional copies of any specific survey or combination of surveys.

Visual wave observations were recorded on a standard BEP scanning form (CERC FORM No. 120-72, 10 May 72) at the time of the observation and simply forwarded to CERC for their files. Each visual wave observation was accompanied by a color transparency photograph taken as described from the top of the sea cliff. These photographs were included as part of the wave observations to be kept on file at CERC. Sediment analysis data for samples collected from Torrey Pines Beach are shown in Appendix H.

#### V. BEACH PROFILE CHANGES

Beach profile measurements made at Torrey Pines Beach have been compared from survey to survey and on a seasonal basis over the 23-month period of the study. The most significant changes in profile configuration occur seasonally so that the results of these measurements are presented for seasonal time intervals.

## 1. Seasonal Changes June 1972 - October 1972.

This study was initiated at a time when Torrey Pines Beach was undergoing the change from a winter configuration to a summer configuration. The first beach profiles were measured on 6 June 1972 at which time the beach had developed a definite berm for the full length of the study area. During the months of July, August, September, and October the beach continued to accrete on the foreshore at all three range lines. This accretion of the foreshore caused the subaerial beach to widen and the berm crest to move seaward. The most likely source for the sand deposited on the beach foreshore was from immediately offshore at depths of -20 feet (-6.1 m) or less, as indicated by the progressive erosion of the 16-foot (4.9 m) reference rods on South Range (Figure 6a). Similar erosion at shallow depths also occurred on North and Indian Canyon Ranges, although the magnitude and progressive removal of sand is not as apparent (Figures 6b and 6c).

Profiles measured on 23 October 72 are representative of the fully developed summer beach configuration in 1972. These profiles were characterized by a sharp berm crest at all three range lines that separated a wide flat backshore from a steeply sloping foreshore. The foreshore slope gradually decreased seaward to form a relatively flat terrace extending offshore from the MSL intercept to about -5 feet (-1.5 meters). The seaward edge of this terrace is marked by a slight increase in the profile slope at a depth of -5 to -10 feet (-1.5 to -3 meters) where the gradual decrease in slope continues out onto the shelf. Formation of the summer beach profile configuration was a gradual process of sand accretion on the beach face and erosion at shallow depths seaward of the surf zone over the period of several months.

## 2. Seasonal Changes November 1972 - April 1973.

The summer beach profile configuration described in the previous section remained intact until 18 November 72 when a storm passed through the study area over a weekend. This storm brought considerable precipitation, high winds and waves coincident with the spring high tides in the month of November. A beach profile survey was made of the three range lines on 21 November 72 immediately following the storm to document modification to the beach. The 21 November 72 profiles indicated that the pronounced berm that had developed on all three range lines was completely removed and the beach was cut back up to 100 feet (30 meters). Erosion on the upper beach was accompanied by sand accretion immediately offshore in depth of -10 to -30 feet (-3 to -9 meters). Reference rod measurements made with this survey show accretion in excess of 1 foot (30 cm) on North Range completely covering the rods at a depth of 16 feet (4.9 m).

Figure 7 is a comparison of the October and November 1972 beach profiles at North Range which indicate that approximately 530 cubic feet

TORREY PINES BEACH-SOUTH RANGE

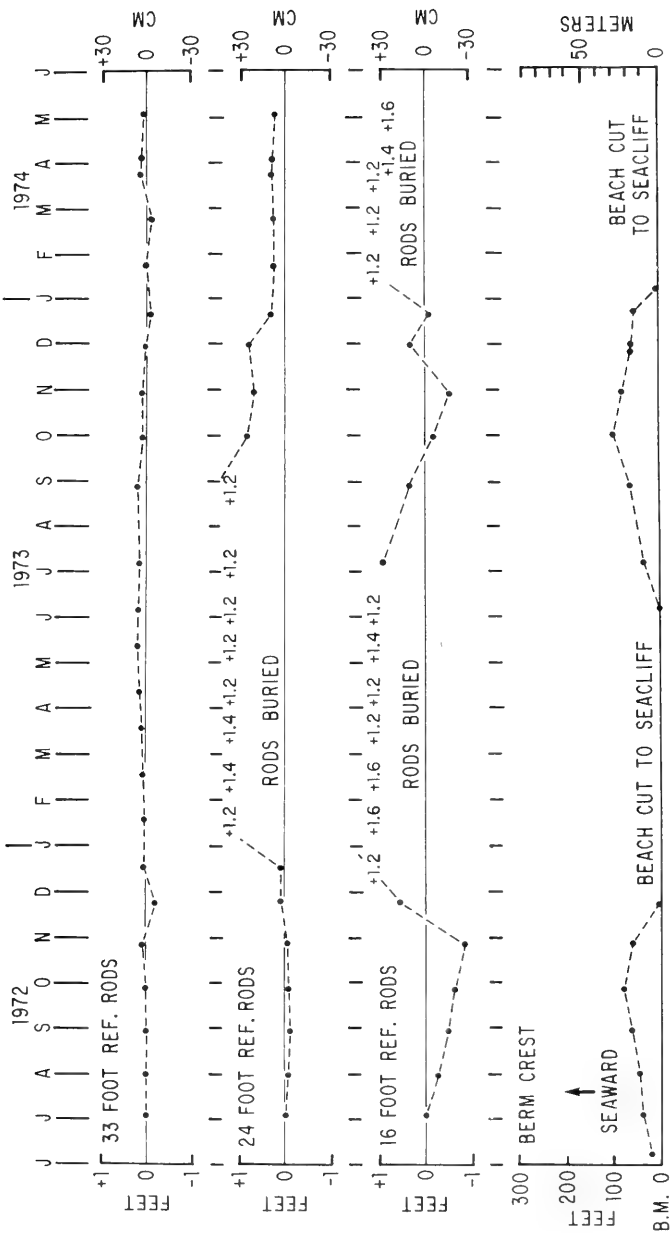

Figure 6a. Berm crest and offshore sand level changes on South Range, June 1972 to June 1974.

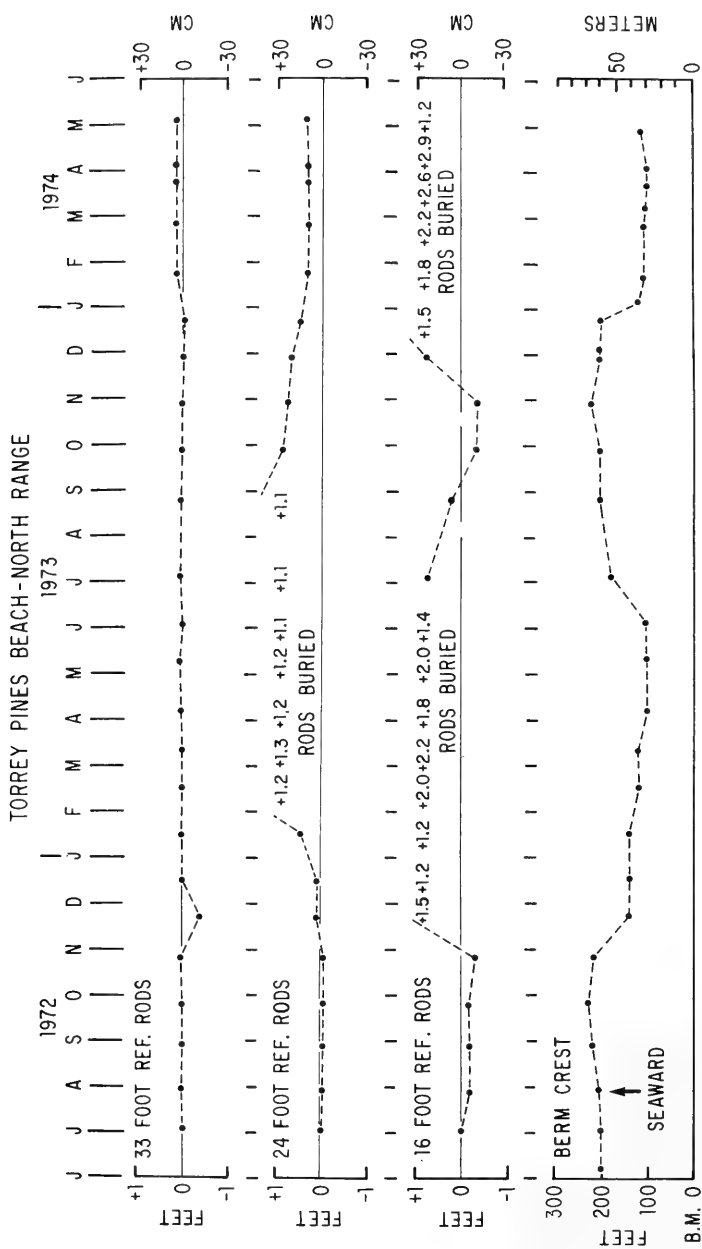

Figure 6b. Berm crest and offshore sand level changes on North Range, June 1972 to June 1974.



TORREY PINES BEACH - INDIAN CANYON

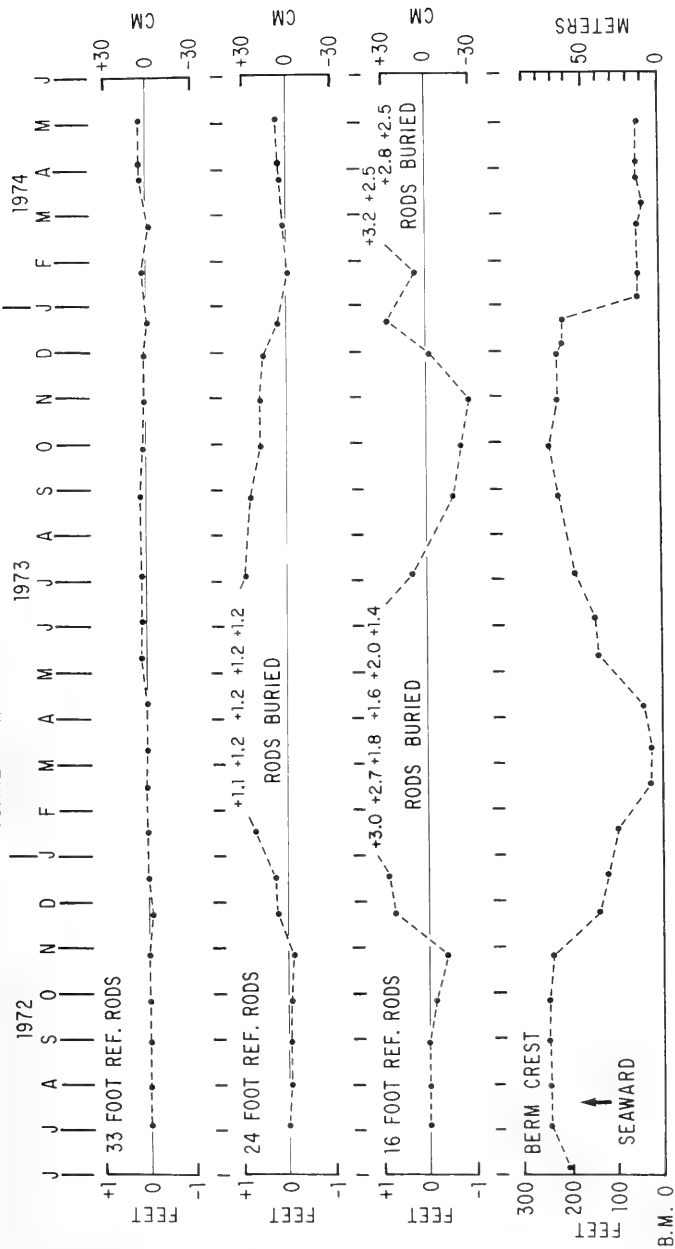

Figure 6c. Berm crest and offshore sand level changes on Indian Canyon Range, June 1972 to June 1974.

# TORREY PINES BEACH - NORTH RANGE

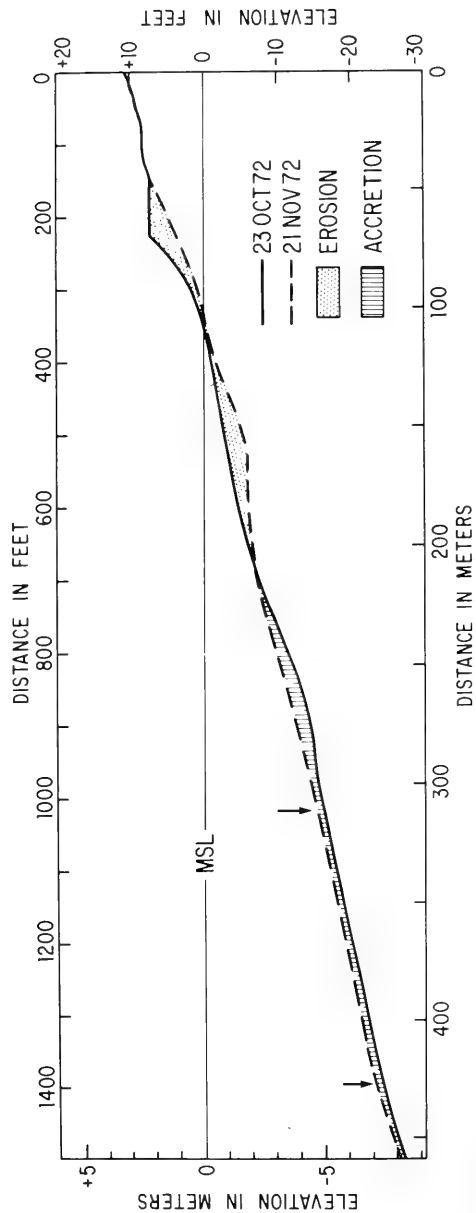

Figure 7. Comparison of October and November 1972 beach profiles showing erosion and accretion of sand associated with storm of 16-20 November 1972. Arrows indicate the positions of reference rod stations.

of sand per foot (49 cubic meters per meter) beach length were eroded from the beach face between +7 feet (2.1 meters) and -7 feet (-2.1 meters). This erosion was matched by an accretion of about 600 cubic feet of sand per foot (56 cubic meters per meter) beach length in depths of -8 to -25 feet (-2.5 to -7.5 meters) below mean sea level. Thus, it appears that most of the sand eroded from the upper part of the beach was transported immediately offshore and deposited at shallow depths.

The profile measurements at Indian Canyon and South Ranges show similar changes in profile configuration and volumes of offshore sand transport related to the storm. This major change in beach configuration was caused by high surf (up to 10-foot breakers) coincident with +6 to +7-foot-high (1.8 to 2.1 meters) tides during the 4-day storm. The high tides enabled the storm surf to overtop the berm crest and quickly erode the beach.

After the storm of 18-20 November 1972, Torrey Pines Beach maintained a winter beach profile configuration with a more gentle foreshore slope. Subsequent storms of lesser intensity during the winter months caused additional erosion of the beach face and accretion at shallow offshore depths. Comparison of beach profiles from the three range lines indicates that the beach responded to the winter storm waves in a similar manner along the full length of the study area.

Figures 6a, b, and c show the progressive retreat of the berm crest and related offshore accretion of sand from November 1972 to April 1973 during the winter. As can be seen, most of the total amount of sand eroded from the beach face during the winter was removed by the storm in November 1972. The remainder of the sand transported offshore during the winter was progressively removed over several months.

Beach profile and reference rod measurements made on 11 April 73 show the final winter configuration of the beach profiles with maximum retreat of the berm crest and the lowest foreshore slope. Figure 8 shows two representative profiles measured at North Range which indicate the magnitude of the total seasonal change in profile configuration. A comparison of the 23 October 72 and 11 April 73 profiles shows the total amount of sand involved in the seasonal change in beach configuration. The quantity of sand eroded from the beach was about 1,300 cubic feet per foot (121 cubic meters per meter) beach length, and the quantity accreted offshore totaled 880 cubic feet per foot (82 cubic meters per meter) beach length. The inequalities in the amount of sand eroded from the upper beach and the amount accreted offshore are probably a result of longshore transport of sand away from the vicinity of the range line. Measurements made on the other range lines indicate a similar seasonal change for the entire section of beach under study.

# TORREY PINES BEACH - NORTH RANGE

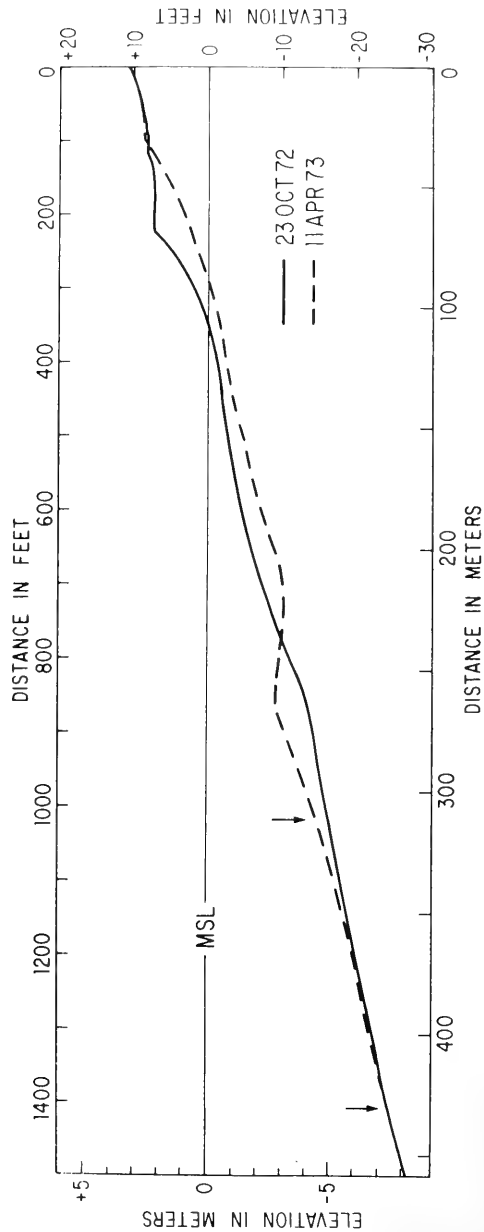

Figure 8. Comparison of beach profiles measured at North Range showing seasonal changes in beach configuration 1972-73. The profile measured on 23 October 1972 shows the summer beach profile configuration in 1972. The profile measured on 11 April 1973 shows the winter configuration during the winter of 1972-73. Arrows indicate the positions of reference rod stations.

### 3. Seasonal Changes April 1973 - October 1973.

Beach profile measurements after April 1973 indicate that the upper foreshore of Torrey Pines Beach began to accrete and construct a new summer berm. Beach profile and reference rod measurements made on 11 May and 6 June 1973 show accretion on all three range lines with the initial onshore movement being the development of a bar at -3 feet (-1 meter) and the progressive accretion of sand at higher elevations on the foreshore to form a new subaerial berm. Figure 10 shows this progressive onshore movement of sand at North Range during April to September 1973. The source of the sand accreting on the beach face was from the area immediately offshore at depths of less than -33 feet (-10 meters) as shown by the interrelation of berm crest progradation and erosion at the shallow reference rods (Figures 6a, b, and c).

The summer beach configuration in 1973 was best typified by the profiles measured on 25 October 1973 when the berm crest had prograded farthest seaward and the foreshore increased in slope. Examination of the 25 October 1973 profile at North Range (Figure 9) shows the beach configuration during the summer season. Approximately 1,300 cubic feet per foot (121 cubic meters per meter) beach length accreted on the beach face while 770 cubic feet per foot (72 cubic meters per meter) beach length were eroded from depths of -10 to -20 feet (-3 to -6.1 meters). Profiles measured on the other two range lines show similar changes during this period.

### 4. Seasonal Changes November 1973 - April 1974.

The summer beach profile configuration shown by the 25 October 73 profile at North Range (Figure 9) remained until the occurrence of 6-foot-high breakers coincident with a +7 foot (2.1 meters) high tide over 7 and 8 January 1974. This period of high waves caused the rapid recession of the subaerial berm and reduction in slope of the beach foreshore. The extreme high tides enabled the high breakers to overtop the berm crest and quickly erode the subaerial beach.

Following this occurrence of high waves, two other periods of high waves and a storm occurred during the spring causing only minor further modification of the beach profile configuration. Figures 6a, b, and c show the change in the position of the berm crest and sand level change at the offshore reference rod stations during the winter and spring of 1973-74. Final winter beach profile configuration is shown by the 4 April 1974 profile at North Range (Figure 9), with the farthest landward recession of the berm crest and gentlest foreshore slope. Profiles at the other three range lines also had similar winter season configurations.

Comparison of the 25 October 73 summer profile and the 4 April 74 winter profile at North Range shown, in Figure 9, indicates the maximum seasonal sand level changes. The volume of sand eroded from beach face was approximately 400 cubic feet per foot (37.4 cubic meters per meter)

### TORREY PINES BEACH - NORTH RANGE

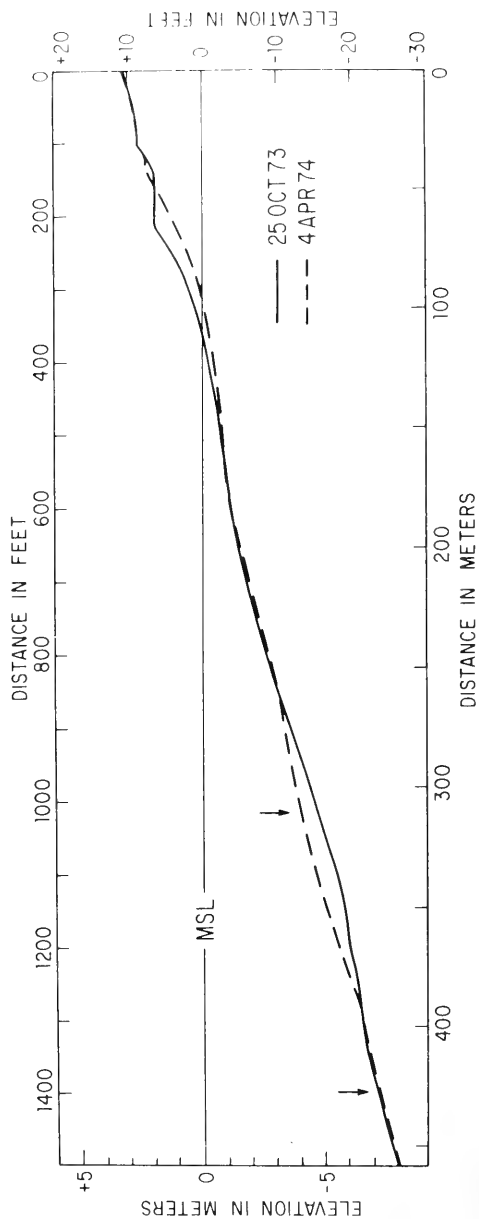

Figure 9. Comparison of beach profiles measured at North Range showing seasonal changes in beach configuration, 1973-74. The profile measured on 25 October 1973 shows the summer beach profile configuration in 1973. The profile measured on 4 April 74 shows the winter configuration during the winter of 1973-74. Arrows indicate the positions of reference rod stations.

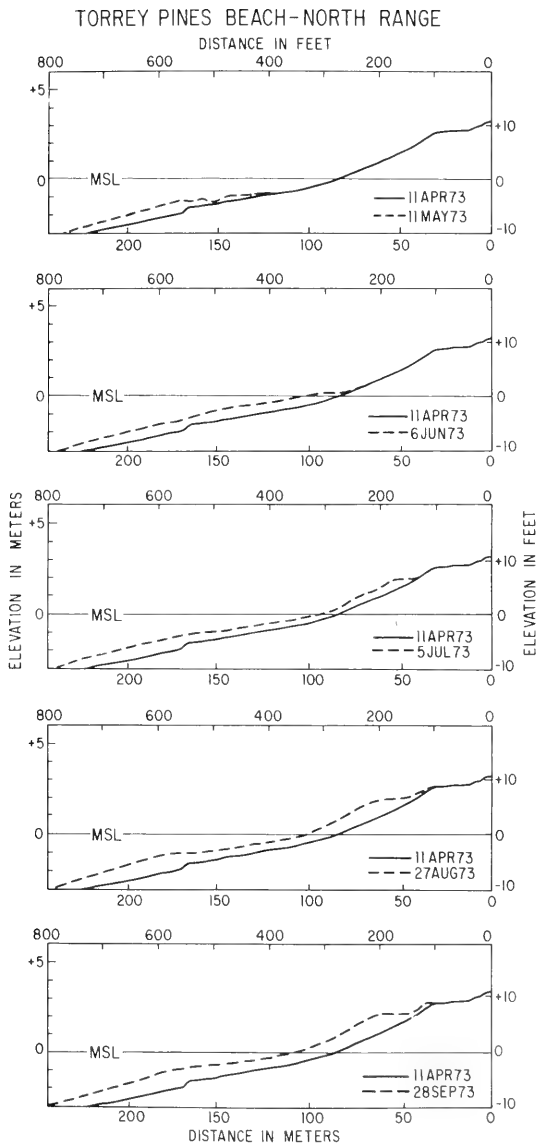

Figure 10. Onshore movement of sand at North Range, May-September 1975.

beach length and the quantity accreted offshore amounted to 640 cubic feet per foot (60 cubic meters per meter) beach length at depths of -10 feet to -20 feet (-3 to -6 meters) below MSL. This comparison indicates that there was a net gain of sand in the offshore area at North Range which is offset by slight net loss of sand in the vicinity of South Range and Indian Canyon Range. The net losses of sand at the two southern range lines and gain at North Range may reflect a net northward littoral transport caused by the high waves approaching from the south on 8-11 January 1974.

The volume of sand involved in the summer to winter profile transition was considerably less during the 1973-74 winter season than for the previous year. This was especially noticeable at North Range where the volume of sand eroded from the beach face in the 1973-74 winter season was approximately one-third that removed during the winter of 1972-73. This difference in sand volume involved in the summer to winter transition in beach profile configuration can be attributed to the relatively mild winter of 1973-74. The difference between the volumes of sand transported offshore during the two winter periods studied is also apparent in Figures 6a, b, and c. The reference rod data show that sand accretion occurred beyond a depth of -24 feet (-7.3 m) in the winter of 1972-73, but that accretion did not extend to depths of -24 feet (-7.3 m) during the winter of 1973-74. The 1973-74 winter had relatively few storms pass through the study area so that only occasional periods of high waves affected the beach.

This study employed the technique of Inman and Rusnak (1956) for determining sand level changes on the shelf in order to accurately determine changes in beach profile configuration. Since these two studies were done in the same general area, it is useful to compare their results. Inman and Rusnak noted that the range of the sand level change exceeded 2 feet (61 cm) at a depth of -18 feet, 0.29 feet (9 cm) at a depth of -30 feet, and 0.16 feet (5 cm) at a depth of -50 feet, indicating a general decrease in the magnitude of sand level change with increase in water depth. The range of sand level change of the three range lines studied at Torrey Pines Beach was 4.1 feet (125 cm) at a depth of -16 feet, 1.5 feet (45.7 cm) at a depth of -24 feet, 0.60 feet (18 cm) at a depth of -33 feet, 0.20 feet (6 cm) at a depth of -45 feet, and no change at a depth of -65 feet. These ranges of sand level change and their decrease in magnitude with increasing depth follow similar trends to those measured by Inman and Rusnak (1956). However, the range of the change was greater at Torrey Pines Beach for similar depths. This may be related to the fact that the waves are somewhat higher at Torrey Pines Beach than off Scripps Beach. It was noted in the earlier study that the sand level was high in summer and low in winter at depths of -18 to -30 feet. This trend was also observed at depths of -16 to -24 feet at Torrey Pines Beach. At Torrey Pines Beach high sand levels at these depths occur in winter and spring (December to July) and low sand levels occur in summer and fall (August to November). The seasonal fluctuation documented in the two separate studies are similar with any differences probably being accounted for by variation in the wave characteristics at the time of each study.



## 5. Storm Associated Changes

Another aspect of this study was an attempt to document the abrupt changes in beach profile configuration caused by storms and periods of high waves. Documentation of these changes was made by profile measurements before and after the occurrence of storms or high waves. However, the problem in this plan was in predicting the occurrence of storms in order to efficiently make "before surveys." The only information available for storm prediction was U. S. Weather Service forecasts for the Pacific coast which were thought to be reliable since most of the local winter storms progress southward along the coast and can be identified before arriving in the study area. However, it was soon realized that it is difficult to predict the occurrence of these storms and to make a representative "before" survey.

During the winter of 1972-73 the first winter storm occurred over the weekend of 18-19 November 72 so that a survey previous to the event was not made, but a survey was made immediately following the storm. This storm caused extensive changes in the beach and essentially altered the profile to a winter configuration. This change in profile configuration was described as part of the seasonal changes between November 1972 to April 1973, and is shown in Figure 7. Several storms and periods of high waves occurred during the 1972-73 winter season following the November storm. Most significant of these were the following:

- |     |                                         |                                                           |
|-----|-----------------------------------------|-----------------------------------------------------------|
| (a) | 9-10 January 1973<br>17 January 1973    | 9-foot-high breakers<br>Beach profile survey              |
| (b) | 12-15 February 1973<br>16 February 1973 | Storm 7- to 10-foot-high breakers<br>Beach profile survey |
| (c) | 12-14 March 1973<br>16 March 1973       | Storm 7- to 10-foot-high breakers<br>Beach profile survey |

Comparisons of the beach profiles made from month to month following these storms and high wave occurrences indicate that each subsequent event had less effect in modifying the profile configuration than the first storm in November 1972.

During the winter season of 1973-74 storm predictions were again based upon U. S. Weather Service forecasts in an attempt to document the changes due to storms with profile surveys. However, the 1973-74 winter season was relatively mild with few storms and occasional occurrences of high waves. The significant surveys and occurrences of high waves during this season were as follows:

- |     |                                         |                                                          |
|-----|-----------------------------------------|----------------------------------------------------------|
| (a) | 4 December 1973                         | Beach profile survey, but storm did not reach area       |
| (b) | 14-15 December 1973<br>17 December 1973 | 7- to 9-foot-high breakers<br>Beach profile survey       |
| (c) | 8 January 1974<br>10 January 1974       | 6- to 8-foot-high breakers<br>Beach profile survey       |
| (d) | 19-20 February 1974<br>21 February 1974 | 7-foot-high breakers<br>Beach profile survey             |
| (e) | 4-8 March 1974<br>11 March 1974         | Storm 6- to 9-foot-high breakers<br>Beach profile survey |

Since most of these events were occurrences of high waves, there was no way to predict the waves and make a "before survey." The most significant occurrence of high waves during the 1973-74 winter season was on 8 January 1974 which was coincident with a +7-foot-high tide which caused considerable change in the configuration of the beach profile. These changes are described in greater detail as part of the seasonal changes between November 1973 and April 1974.

Comparisons of pressure sensor records from February 1973 with the winter of 1973-74 show February 1973 to have been a period of high waves. The mean significant height derived for February 1973 is 1.4 meters as compared to 1.0 meter for the winter of 1973-74, and, in fact, the highest waves observed during the study occurred during February 1973. Thus, the mean height of waves during February 1973 was approximately 30 percent greater than that of other winter months. A check of annual precipitation records for the San Diego region also suggests that 1972-73 was one of the four wettest years in the last 20 years. Since most of the precipitation in San Diego area comes from winter storms, this may be a reasonable indication of the severity of the winter season.

## VI. CONCLUSIONS

The beach profile measurements at Torrey Pines Beach, California, have provided some insight into the seasonal changes in beach profile configuration on a straight beach with uniform offshore slope that is exposed to waves from all offshore quadrants. The conclusions of this study can be summarized as follows:

1. The three range lines established on Torrey Pines Beach responded in a similar manner in all sand level changes so that the study site section of beach was not anomalous along its length.

2. All significant changes in beach profile configuration can be related to the incident waves, tides, and to local storms with strong onshore winds.

3. Formation of a summer beach profile configuration is the result of a progressive onshore migration of sand from depths of less than -33 feet (10 meters) which accretes on the beach face.

4. The summer beach profile is characterized by a pronounced berm crest which is produced by the progressive accretion of sand starting as a bar at depths of -3 feet (-1 meter).

5. The summer beach profile configuration did not fully develop until October in 1972 and 1973 when the berm crest was prograded the farthest seaward and beach face slope was the steepest.

6. The change from summer to winter profile configuration occurred abruptly with the coincidence of high waves and spring high tides in November 1972.

7. At the time of high waves and tides the summer profile berm crest was easily overtopped by wave runup and the upper foreshore quickly eroded.

8. Most of the sand transported offshore during the winter seasonal change was removed from the beach face during the few days when high waves and tides were coincident.

9. Sand transported offshore during the winter seasonal change in profile configuration was deposited in depths of -10 to -30 feet (-3 to -9 meters).

10. There were no recorded sand level changes at depths greater than -45 feet (-13.7 meters) on the deeper reference rod stations at Indian Canyon Range.

11. Comparisons between the visual wave observations and the pressure sensor measurements at South Range show that there is agreement between the two sets of data for the angle of wave approach under conditions when there is a single, predominant wave present. Visual observations are much less valid under complex sea conditions.

## LITERATURE CITED

- BRUNN, P., "Coast Erosion and the Development of Beach Profiles," TM-44, U.S. Army, Corps of Engineers, Beach Erosion Board, Washington, D.C., June 1954.
- CHAMBERLAIN, T.K., "Mechanics of Mass Sediment Transport in Scripps Submarine Canyon," Ph.D. Dissertation, University of California, Los Angeles, Calif., unpublished, June 1960.
- INMAN, D.L., "Measures for Describing the Size Distribution of Sediments," *Journal of Sedimentary Petrology*, Vol. 22, No. 3, Sept. 1952, pp. 125-145.
- INMAN, D.L., "Areal and Seasonal Variations in Beach and Nearshore Sediments at La Jolla, California," TM-39, U.S. Army, Corps of Engineers, Beach Erosion Board, Washington, D.C., Mar. 1953.
- INMAN, D.L., "Wave Climate at Torrey Pines Beach, California," Final Report under Contract DACW72-72-C-0021, U.S. Army, Corps of Engineers, Coastal Engineering Research Center, Fort Belvoir, Va. (in preparation, 1975).
- INMAN, D.L., and RUSNAK, G.A., "Changes in Sand on the Beach and Shelf at La Jolla, California," TM-82, U.S. Army, Corps of Engineers, Beach Erosion Board, Washington, D.C., July 1956.
- SAVILLE, T., Jr., and CALDWELL, J.M., "Accuracy of Hydrographic Surveying In and Near the Surf Zone," TM-32, U.S. Army, Corps of Engineers, Beach Erosion Board, Washington, D.C., Mar. 1953.
- SHEPARD, F.P., "Beach Cycles in Southern California," TM-20, U.S. Army, Corps of Engineers, Beach Erosion Board, Washington, D.C., July 1950.
- SHEPARD, F.P., and INMAN, D.L., "Sand Movement on the Shallow Inter-canyon Shelf at La Jolla, California," TM-26, U.S. Army, Corps of Engineers, Beach Erosion Board, Washington, D.C., Nov. 1951.
- STATE OF CALIFORNIA, "Interim Report on Study of Beach Nourishment Along the Southern California Coastline," Department of Water Resources, Southern District, Sacramento, Calif., July 1969.

## APPENDIX A

### DESCRIPTION OF RANGE LINES AND BENCH MARKS

#### TORREY PINES BEACH, CALIFORNIA

#### INTRODUCTION

Three range lines normal to the shoreline were established on Torrey Pines Beach for use in making repeated measurements of sand level change in the onshore-offshore direction. Each range line was marked with two bench marks (BM) that define the direction of the range line and elevation of two fixed points relative to a datum. The three range lines are referred to as South Range, Indian Canyon Range, and North Range to designate their geographic position relative to Indian Canyon.

#### RANGE LINE LOCATION SURVEY

The closest Government bench mark to the section of Torrey Pines Beach under study is the U.S. Coast and Geodetic Survey (USCGS) Bench Mark "Ball" located in the NW 1/4 of Section 12, Township 15 South Range 4 West from the San Bernardino meridian and base line. The bench mark is a brass disc identified as a USCGS monument at the top of the sea cliff about 1/2 mile south of South Range which designates a point 326.3 feet above mean sea level. This brass disc served as the point of origin for the range line location survey (Figure A-1). Since the USCGS bench mark is located at the top of the sea cliff, the range line location survey was necessarily performed in two segments that were tied together using a specialized type of surveying technique. The first segment was a level line survey from USCGS "Ball" to an established point at the top of the sea cliff on South Range. This was done using a transit, tape, and rod for measuring elevation and horizontal distance to  $\pm 0.01$  foot. Figure A-2 shows the plan of the first survey segment with the location of transit station, rod station, and measured lines as listed in Table A-1.

This survey segment resulted in the location of four points lying on South Range as shown in Figure A-2. These points are:

- a. "+" chiseled in the concrete base of the U.S. Navy southwest range marker.
- b. A 1/2-inch-diameter stainless steel pipe at the top of the sea cliff.
- c. Two 1/2-inch-diameter stainless steel pipes approximately 50 feet apart at the foot of the sea cliff.

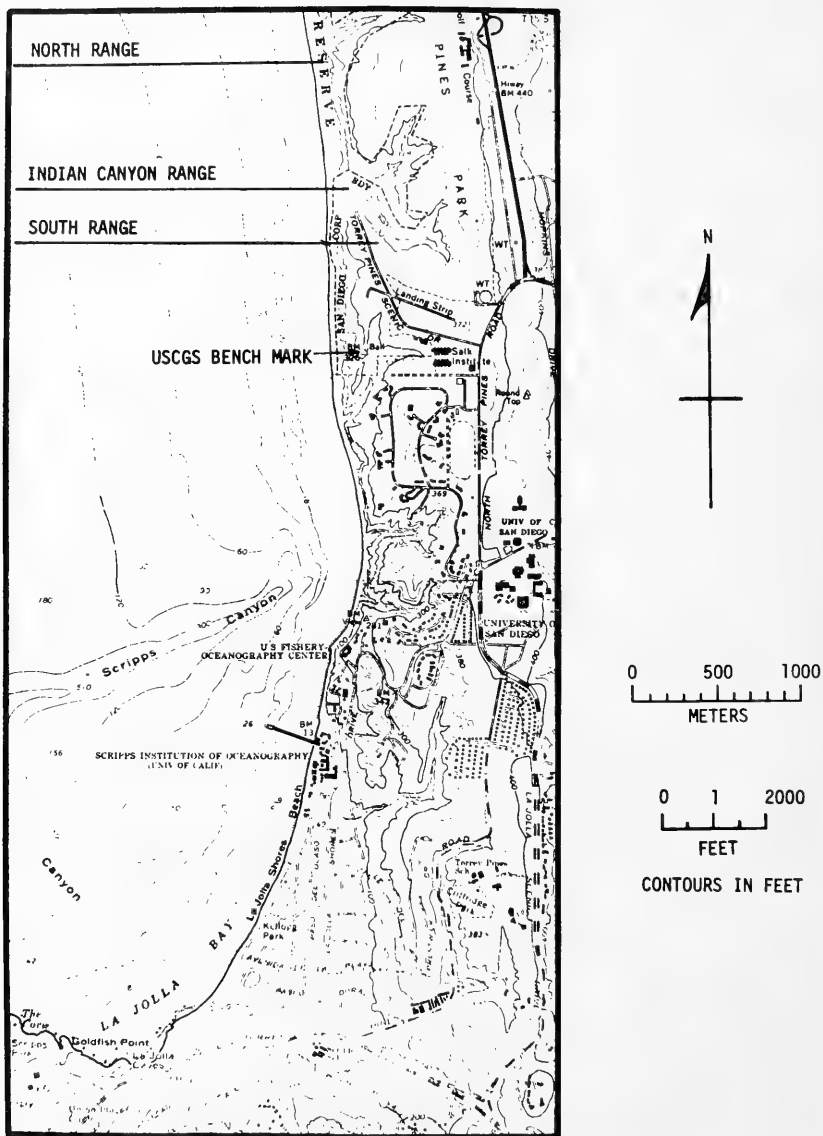

Figure A-1. Location map for beach profile range lines on Torrey Pines Beach, California.

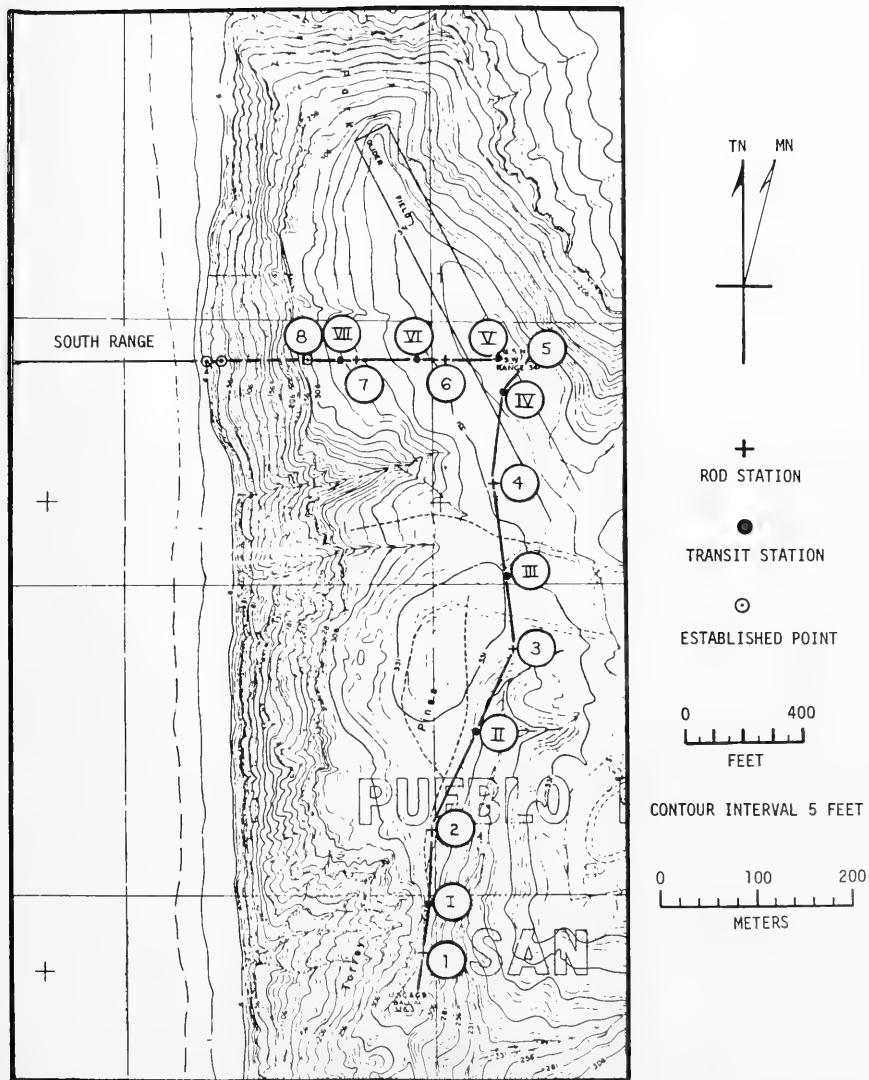

Figure A-2. Plan of survey from USCGS bench mark to South Range.

Table A-1. Notes for survey from USCGS "ball" to bench mark at cliff top on South Range.

Transit Station	Height of Instr. (Ft)	Rod Sta.	Direct. Rel. to Mag. N.	Dist. (Ft)	Backsite Rod Reading (Ft)	Foresite Rod Reading (Ft)	Difference in Elev. (Ft)	Elev. Rel. to Datum (Ft)	Notes
BM Ball	4.5	1	N5°W	166.15		9.07	-4.52	326.30	MSL Datum
BM Ball		1	S10°E	161.20	3.26			321.78	
I		2	N10°W	240.20		2.15	+1.11	322.89	
II		2	S10°W	364.35	4.66				
II		3	N10°E	285.90		1.52	+3.14	326.03	
III		3	S20°E	225.30	6.37				
III		4	N20°W	522.45		4.85	+1.52	327.55	
IV		4	S13°E	290.90	12.25				
IV		5	N37°E	119.60		3.22	+9.03	336.58	Cross chiseled on USN SW Range
V		5	N76°E	93.10	4.50				
V		6	S76°W	173.95		13.76	-9.26	327.32	
VI		6	N76°E	97.50	0.10				
VI		7	S76°W	200.10		14.70	-14.60	312.72	
VII		7	N76°E	43.20	0.79				
VII		8	S76°W	92.20		13.64	-12.85	299.87	Pipe in ground at cliff edge on Range
				Total	36.48	62.91	-26.43		



The second segment of the range line location survey was a level line survey beginning at the most seaward pipe on South Range north along the beach to North Range. Figure A-3 shows the plan of the second segment of the range line survey with the transit stations, rod stations, and measured lines as listed in Table A-2.

This survey segment resulted in the location of four additional points as shown in Figure A-3. These points are:

- a. Two 1/2-inch-diameter stainless steel pipes approximately 45 feet apart at the mouth of Indian Canyon on Indian Canyon Range; and
- b. Two 1/2-inch-diameter stainless steel pipes approximately 30 feet apart on North Range.

These additional established points define the location of Indian Canyon Range and North Range.

A specialized surveying technique was used to determine the distance between points located at the top and bottom of the sea cliff on South Range. This involved setting up the survey as a trigonometric problem in which the vertical angle and the distance between points at the top and bottom of the cliff are measured in order to define a triangle as shown in Figure A-4. A trigonometric solution of the right triangle provides the difference in elevation between the point at the top of the cliff and the point at the bottom of the cliff. In order to determine the difference in elevation between the two points to the nearest 0.01 foot, an exact measurement of the line-of-sight distance between the points at the top and bottom of the cliff had to be made. This was accomplished by using a Hewlett-Packard 3800A Distance Meter. Exact measurement of line-of-sight distance to the nearest 0.001 foot for distance up to 3,000 feet is possible with this instrument. Two independent measurements of the distance between points at the cliff top and bottom resulted in measurements of 505.182 and 505.185 feet respectively. Thus, a slope distance of 505.18 feet was used for the calculation of the difference in elevation. The vertical angle of slope for the measurements was determined to be  $35^{\circ}56'$  by a transit. Trigonometric solution of the right triangle and consideration of the instrument offsets results in a difference in elevation of 291.10 feet between the pipe bench mark at the cliff top and the S10 I bench mark on the beach (see Figure A-4). This determination of the elevation of S10 I bench mark provided the necessary link between the two segments of the range line location survey and established the exact elevation of the S10 II and S10 III bench marks on the beach.

#### RANGE LINE BENCH MARK DESCRIPTION

Each range line is located by two permanent bench marks. These bench marks are 1/2-inch-diameter stainless steel pipes 36 inches long

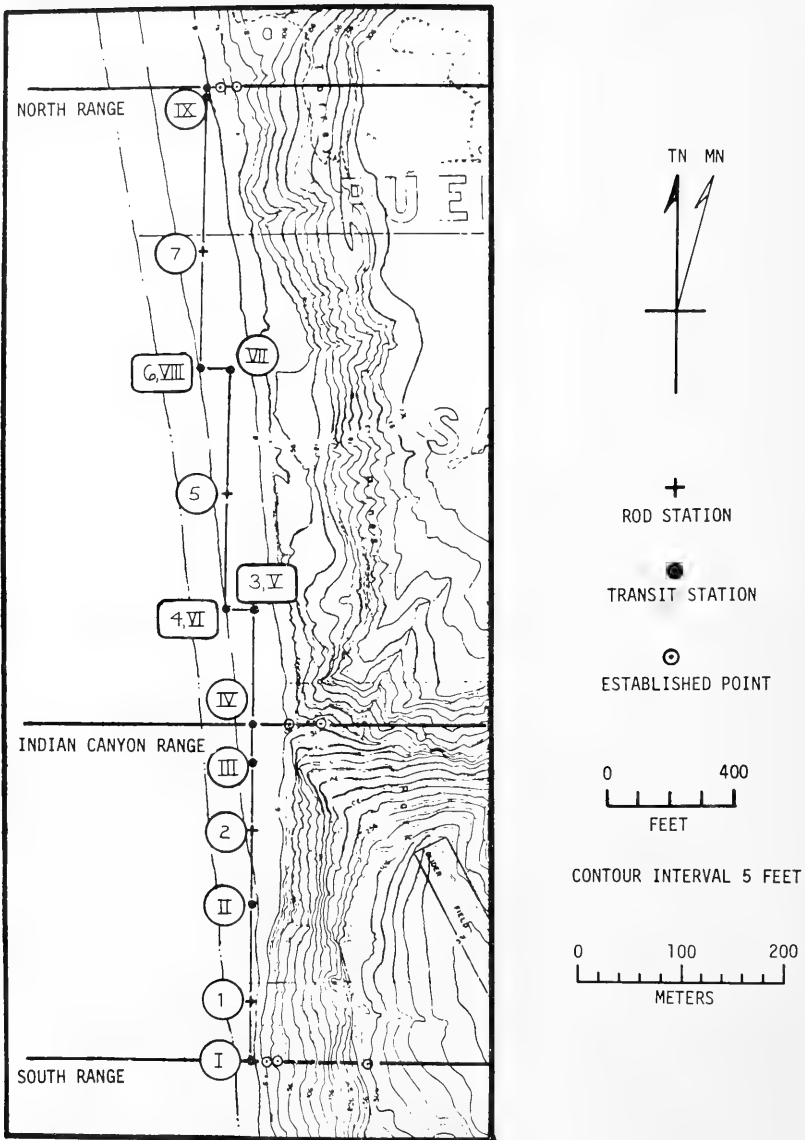

Figure A-3. Plan of survey from South Range to North Range, Torrey Pines Beach, California.

Table A-2. Notes for survey from South Range (SIO I B.M.) to North Range (SIO III B.M.) on Torrey Pines Beach.

Transit Station	Height of Instr. (Ft)	Rod Sta.	Direct. Rel. to Mag. N.	Dist. (Ft)	Backsite Rod Reading (Ft)	Foresite Rod Reading (Ft)	Difference in Elev. (Ft)	Elev. Rel. to Datum (Ft)	Notes
I	3.95	SIO I BM	N76°E	50.00	2.07			8.77	South Range
I		1	N14°W	200.00		3.96	-1.89	6.88	
II	4.10	1	S14°E	350.00	5.65			6.78	
II		2	N14°W	250.00		5.75	-0.10	6.78	
III	4.30	2	S14°E	235.50	5.35			9.98	Indian Canyon Range
III		SIO II BM	N44°E	193.60		2.15	+3.20	9.98	
				Total	13.07	11.86	+1.21		
IV	4.20	SIO III BM	N76°E	101.80	1.77			9.98	Indian Canyon Range
IV		3	N14°W	400.00		3.78	-2.01	7.97	
V	4.51	4	S76°W	100.00	4.51	4.62	-0.11	7.86	Western offset of survey line
VI	4.50	5	N14°W	400.00	4.50	4.46	+0.04	7.90	
VII	4.22	5	S14°E	443.60	5.46			8.41	Western offset of survey line
VII		6	S76°W	100.00		4.95	+0.51	8.41	
VIII	4.20	7	N14°W	400.00	4.20	4.87	-0.67	7.74	
IX	3.80	7	S14°E	544.20	3.75			7.45	
IX		8	N14°W	12.20		4.04	-0.29	10.91	
X	4.21	SIO III BM	N76°E	35.00	4.21	0.75	+3.46	10.91	North Range
				Total	28.40	27.47	+0.93		

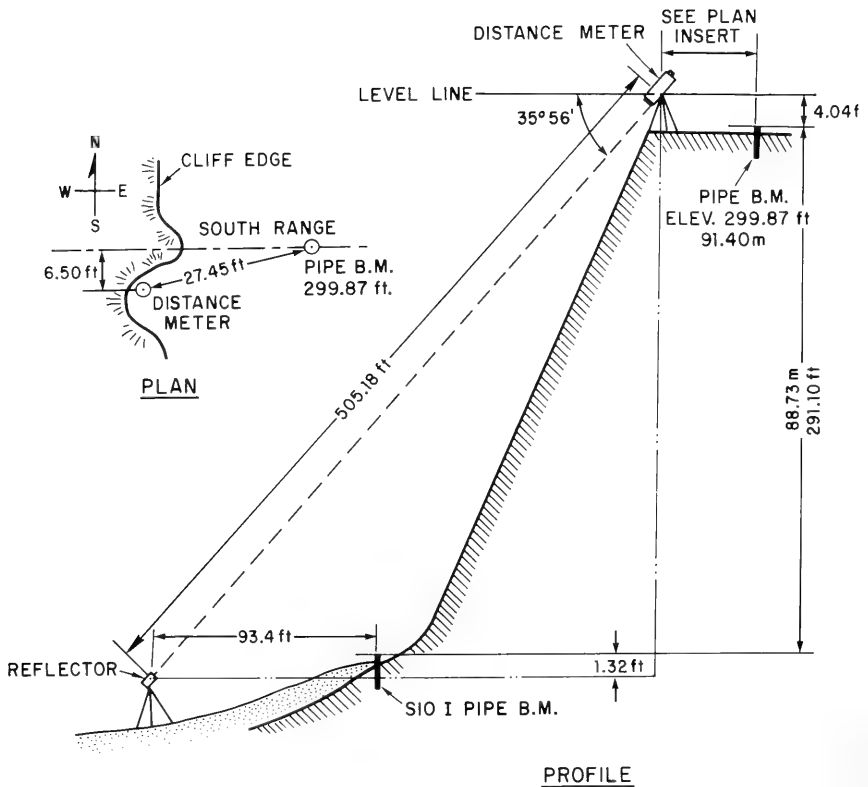

Figure A-4. Schematic diagram of survey procedure to determine the difference in elevation between bench marks at the top of the sea cliff and on the beach for South Range.

that have been driven into the ground to the ground surface. The pipes were then set in place with concrete to a depth of 24 inches. The seaward pipe was capped with a 3-inch brass plug that has the bench mark designation engraved on its upper surface. The bench marks were designated SIO I (South Range), SIO II (Indian Canyon Range), and SIO III (North Range) as shown below:



The primary bench mark, as described above, was placed in the bedrock at the landward margin of the beach. This location allowed both ready access for survey use and also provided some protection from loss by erosion of the beach. A secondary bench mark was placed on the range about 50 to 100 feet landward of the primary bench mark. These bench marks were necessarily located up on the talus slope at the base of the sea cliff and are identical to the primary bench mark except that the pipe was not capped. Elevations of the bench marks for each range are given below:

Range	Bench Mark	Elevation of Primary B.M. Rel. MSL	Elevation of Secondary B.M. Rel. MSL
South	SIO I	8.77 ft	42.67 ft
Indian Canyon	SIO II	9.98 ft	29.92 ft
North	SIO III	10.91 ft	32.10 ft

Alinement on the range line is accomplished by using flags to mark the two bench mark pipes so that the rodman or boat operator can position a point on the range. Distances along the range are determined by tape measurement from the primary bench mark or by plotting the boat position from horizontal sextant angles between flags marking adjacent ranges. Elevations along ranges are determined by surveying a level line from the primary bench mark. Fathometer soundings are corrected to mean sea level to provide the corresponding data offshore. The onshore and offshore surveys are combined into a single profile by referencing all data points to the MSL datum.

APPENDIX B

DISTANCE-ELEVATION DATA FOR BEACH PROFILES SURVEYED  
AT TORREY PINES BEACH, CALIFORNIA

June 1972 - April 1974

Definition of terms:

1. Distance - is the horizontal distance along the range line seaward from the bench mark.
2. Elevation - is the vertical distance at each profile station relative to mean sea level.
3. Reference rod - is the vertical distance relative to mean sea level based upon the mean of the four reference rod readings at the reference rod station.

6 June 1972

<u>SOUTH RANGE</u>		<u>INDIAN CANYON RANGE</u>		<u>NORTH RANGE</u>	
<u>Dist.</u>	<u>Elev.</u>	<u>Dist.</u>	<u>Elev.</u>	<u>Dist.</u>	<u>Elev.</u>
<u>Feet</u>	<u>Feet</u>	<u>Feet</u>	<u>Feet</u>	<u>Feet</u>	<u>Feet</u>
0	8.80	0	10.10	0	10.90
20	8.40	20	9.30	20	9.80
40	7.30	40	8.60	40	9.30
60	6.60	60	8.10	60	9.10
80	6.00	80	7.80	80	8.20
100	4.50	100	7.60	100	8.10
120	3.40	120	7.60	120	7.60
140	2.30	140	7.40	140	7.20
160	1.40	160	7.10	160	6.90
180	0.50	180	6.80	180	7.10
200	-0.20	200	6.60	200	6.60
220	-0.50	220	6.10	220	5.20
240	-1.00	240	5.10	240	5.30
260	-1.30	260	4.10	260	4.60
280	-1.70	280	3.10	280	3.10
300	-2.70	300	2.10	300	1.80
320	-2.20	320	1.10	320	0.60
340	-2.70	340	0.30	340	-0.50
360	-3.40	360	-0.20	360	-1.20
380	-3.10	380	-0.60	380	-1.70
400	-3.10	400	-0.90	400	-2.30
420	-3.60	420	-1.30	420	-2.70
440	-4.20	440	-1.60	440	-3.20
460	-4.60	460	-1.70	460	-3.80
480	-5.10	480	-2.30	500	-5.30
660	-8.40	500	-2.20	520	-6.30
855	-11.40	520	-3.10	540	-7.10
1020	-16.20	540	-3.20	885	-14.90
1200	-20.10	560	-3.60	1005	-17.40
1360	-23.40	580	-4.20	1125	-19.80
1525	-26.60	820	-16.10	1310	-23.60
1730	-30.40	1000	-20.10	1460	-26.20
1930	-34.20	1195	-24.10	1620	-29.10
2100	-37.20	1370	-27.10	1865	-33.10
2280	-40.20	1545	-31.10	2045	-36.20
2500	-44.10	1740	-35.10	2210	-39.20
2650	-46.80	1930	-38.10	2320	-41.10
2845	-50.20	2125	-41.10	2475	-44.10
3010	-53.10	2285	-44.10	2675	-47.30
3210	-56.60	2465	-47.10	2895	-51.10
		2660	-50.10	3015	-53.30
		2795	-52.10	3140	-55.40
		2980	-55.10		

<u>SOUTH RANGE</u>		<u>INDIAN CANYON RANGE</u>		<u>NORTH RANGE</u>	
<u>Dist.</u>	<u>Elev.</u>	<u>Dist.</u>	<u>Elev.</u>	<u>Dist.</u>	<u>Elev.</u>
<u>Feet</u>	<u>Feet</u>	<u>Feet</u>	<u>Feet</u>	<u>Feet</u>	<u>Feet</u>
0	8.80	0	10.10	0	10.90
20	8.50	20	9.40	20	9.80
40	8.00	40	8.60	40	8.90
60	6.60	60	8.10	60	9.10
80	6.20	80	8.10	80	8.10
100	5.20	100	7.70	100	8.20
120	4.10	120	7.60	120	7.70
140	3.10	140	7.60	140	7.50
160	1.90	160	7.20	160	7.10
180	0.80	180	7.40	180	7.10
200	0.20	200	6.70	200	7.10
220	-0.20	220	6.30	220	6.10
240	-0.50	240	6.30	240	5.10
260	-0.90	260	4.80	260	3.80
280	-1.10	280	3.60	280	2.60
300	-1.40	300	2.40	300	1.40
320	-1.60	320	1.40	320	-0.30
340	-1.90	340	0.60	340	-1.30
360	-2.20	360	-0.10	360	-1.90
380	-2.60	380	-0.60	380	-2.60
400	-3.20	400	-1.10	400	-2.70
420	-3.50	420	-1.20	420	-3.10
440	-3.50	440	-1.60	440	-3.40
460	-3.30	460	-1.80	460	-3.90
480	-3.40	480	-2.10	480	-4.60
500	-3.70	500	-2.40	500	-5.10
520	-4.00	520	-2.70	520	-5.60
540	-4.40	540	-3.10	540	-5.70
560	-4.90	560	-3.30	560	-5.80
760	-9.20	580	-3.60	580	-5.90
905	-13.20	610	-6.10	585	-6.90
1040	-16.80	735	-14.10	600	-6.10
1165	-19.40	900	-18.10	620	-6.20
1315	-22.40	1050	-21.10	640	-6.60
1465	-25.30	1240	-25.10	660	-6.90
1620	-28.30	1390	-28.10	680	-7.20
1750	-30.90	1565	-31.10	700	-7.70
2145	-38.10	1720	-34.10	955	-16.30
2265	-40.10	1885	-37.10	1065	-18.60
2380	-42.10	2050	-40.10	1185	-21.10
2485	-44.10	2160	-42.10	1350	-24.60
2570	-45.40	2365	-45.10	1460	-26.20
		2565	-48.10	1610	-28.80
		2720	-51.10	1700	-30.20



3 July 1972 (Cont'd)

<u>SOUTH RANGE</u>		<u>INDIAN CANYON RANGE</u>		<u>NORTH RANGE</u>	
Dist. Feet	Elev. Feet	Dist. Feet	Elev. Feet	Dist. Feet	Elev. Feet
		2835	-53.10	1935	-34.30
		3015	-55.10	2050	-36.40
		3185	-58.10	2240	-39.80
				2385	-42.20
				2515	-44.60
				2605	-46.10
				2750	-48.60
				2855	-50.60

<u>SOUTH RANGE</u>		<u>INDIAN CANYON RANGE</u>		<u>NORTH RANGE</u>	
<u>Dist.</u>	<u>Elev.</u>	<u>Dist.</u>	<u>Elev.</u>	<u>Dist.</u>	<u>Elev.</u>
<u>Feet</u>	<u>Feet</u>	<u>Feet</u>	<u>Feet</u>	<u>Feet</u>	<u>Feet</u>
0	8.80	0	10.10	0	10.90
20	8.60	20	9.40	20	9.90
40	8.00	40	8.80	40	9.10
60	7.00	60	8.10	60	8.90
80	6.70	80	7.90	80	8.30
100	5.70	100	7.70	100	8.20
120	4.60	120	7.60	120	8.20
140	3.60	140	7.60	140	7.60
160	2.50	160	7.30	160	7.10
180	1.60	180	7.20	180	7.10
200	1.10	200	7.30	200	7.10
220	0.70	220	7.10	220	7.10
240	0.30	240	7.40	240	6.30
260	-0.10	260	5.60	260	4.70
280	-0.40	280	4.60	280	3.20
300	-0.80	300	3.10	300	2.10
320	-1.00	320	2.10	320	1.10
340	-1.30	340	1.20	340	0.30
360	-1.60	360	0.70	360	-0.20
380	-2.10	380	0.30	380	-0.70
400	-2.30	400	0.10	400	-0.80
420	-2.50	420	-0.30	420	-1.10
1120	-18.20	440	-0.60	440	-1.60
1235	-20.70	460	-0.90	460	-2.10
1400	-24.10	480	-1.20	480	-2.90
1550	-26.90	500	-1.70	500	-3.60
1690	-29.60	520	-2.10	520	-4.30
1850	-32.60	540	-2.60	540	-5.10
1990	-35.10	560	-3.40	1050	-18.20
2150	-37.80	785	-12.40	1220	-21.70
2295	-40.30	870	-16.40	1385	-24.90
2440	-43.10	1000	-19.80	1525	-27.30
2580	-45.40	1160	-22.90	1695	-30.20
2725	-48.10	1300	-25.70	1865	-33.10
2835	-49.90	1455	-28.70	1970	-35.10
3000	-52.70	1585	-31.30	2170	-38.40
		1760	-34.70	2315	-41.10
		1890	-36.90	2445	-43.20
		2020	-39.30	2605	-46.10
		2180	-42.10	2740	-48.40
		2340	-44.90	2910	-51.30
		2485	-47.20	3035	-53.60
		2580	-48.80	3210	-56.60

31 July 1972 (Cont'd)

<u>SOUTH RANGE</u>		<u>INDIAN CANYON RANGE</u>		<u>NORTH RANGE</u>	
<u>Dist.</u>	<u>Elev.</u>	<u>Dist.</u>	<u>Elev.</u>	<u>Dist.</u>	<u>Elev.</u>
<u>Feet</u>	<u>Feet</u>	<u>Feet</u>	<u>Feet</u>	<u>Feet</u>	<u>Feet</u>
		2750	-51.40		
		2940	-54.20		
		3225	-58.60		
		3360	-60.60		
Ref. Rods:		Ref. Rods:		Ref. Rods:	
1011	-16.30	816	-16.00	942	-16.20
1375	-24.10	1219	-24.00	1331	-24.00
1866	-33.00	1667	-33.00	1862	-33.00
		2343	-45.00		
		3635	-65.00		

28 August 1972

<u>SOUTH RANGE</u>		<u>INDIAN CANYON RANGE</u>		<u>NORTH RANGE</u>	
<u>Dist.</u> <u>Feet</u>	<u>Elev.</u> <u>Feet</u>	<u>Dist.</u> <u>Feet</u>	<u>Elev.</u> <u>Feet</u>	<u>Dist.</u> <u>Feet</u>	<u>Elev.</u> <u>Feet</u>
0	8.80	0	10.10	0	10.90
20	8.30	20	9.10	20	9.90
40	7.70	40	8.40	40	9.10
60	7.10	60	7.80	60	9.10
80	7.20	80	7.70	80	8.40
100	5.40	100	7.40	100	8.30
120	4.10	120	7.20	120	8.20
140	3.00	140	7.10	140	7.60
160	2.20	160	7.10	160	7.30
180	1.70	180	6.90	180	7.30
200	1.10	200	7.10	200	7.40
220	0.60	220	7.20	220	7.30
240	0.20	240	6.80	240	6.10
260	-0.30	260	4.80	260	4:20
280	-0.70	280	3.30	280	2.70
300	-1.00	300	2.30	300	1.60
320	-1.20	320	1.40	320	0.80
340	-1.50	360	0.30	340	0.10
360	-1.80	380	-0.20	360	-0.40
380	-2.10	400	-0.60	380	-0.80
400	-2.30	420	-0.90	400	-1.20
420	-2.70	440	-1.30	420	-1.60
440	-3.00	460	-1.60	440	-1.80
460	-3.40	480	-1.80	460	-2.10
1075	-17.80	500	-2.10	480	-2.40
1210	-20.40	520	-2.60	500	-2.70
1380	-23.80	540	-2.80	520	-3.10
1535	-26.70	560	-3.20	540	-3.30
1675	-29.40	580	-3.40	560	-3.90
1815	-32.10	600	-3.70	690	-6.60
1960	-34.80	690	-10.50	885	-14.90
2090	-37.10	785	-15.60	1055	-18.30
2230	-39.40	900	-18.10	1245	-22.20
2380	-42.10	1040	-20.60	1425	-25.60
2550	-45.10	1165	-23.10	1515	-27.30
2660	-47.10	1320	-26.10	1610	-28.90
2750	-48.60	1465	-29.10	1755	-31.30
2945	-52.10	1600	-31.60	1845	-32.90
3060	-54.10	1775	-35.10	2035	-36.40
3240	-57.20	1910	-37.60	2170	-38.60
		2040	-39.60	2320	-41.30
		2170	-42.10	2435	-43.20
		2260	-43.60		
		2340	-45.10		
		2465	-47.10		
		2605	-49.10		

28 August 1972 (Cont'd)

<u>SOUTH RANGE</u>		<u>INDIAN CANYON RANGE</u>		<u>NORTH RANGE</u>	
<u>Dist.</u> <u>Feet</u>	<u>Elev.</u> <u>Feet</u>	<u>Dist.</u> <u>Feet</u>	<u>Elev.</u> <u>Feet</u>	<u>Dist.</u> <u>Feet</u>	<u>Elev.</u> <u>Feet</u>
Ref. Rods:		Ref. Rods:		Ref. Rods:	
1011	-16.50	816	-16.00	942	-16.10
1375	-24.10	1219	-24.00	1331	-24.00
1866	-33.00	1667	-33.00	1862	-33.00
		2343	-45.00		
		3635	-65.00		

25 September 1972

<u>SOUTH RANGE</u>		<u>INDIAN CANYON RANGE</u>		<u>NORTH RANGE</u>	
<u>Dist.</u>	<u>Elev.</u>	<u>Dist.</u>	<u>Elev.</u>	<u>Dist.</u>	<u>Elev.</u>
<u>Feet</u>	<u>Feet</u>	<u>Feet</u>	<u>Feet</u>	<u>Feet</u>	<u>Feet</u>
0	8.80	0	10.10	0	10.90
20	8.30	20	9.40	20	9.90
40	7.70	40	8.70	40	9.10
60	7.60	60	8.10	60	9.00
80	6.60	80	8.10	80	9.10
100	5.40	100	7.70	100	8.20
120	4.20	120	7.60	110	8.20
140	3.40	140	7.60	120	8.20
160	2.60	160	7.40	130	7.70
180	2.00	180	7.30	140	7.60
200	1.50	200	7.40	150	7.40
220	1.00	220	7.60	160	7.20
240	0.60	240	7.60	170	7.20
260	0.30	260	5.20	180	7.20
280	-0.10	280	3.90	190	7.20
300	-0.50	300	2.90	200	7.30
320	-0.80	320	2.30	210	7.40
340	-1.10	340	1.60	220	7.40
360	-1.40	360	1.10	230	7.20
380	-1.60	380	0.60	240	6.10
400	-1.90	400	0.10	250	5.00
420	-2.20	420	-0.10	260	4.10
440	-2.70	440	-0.40	270	3.30
460	-3.10	460	-0.70	280	2.70
480	-3.40	480	-1.10	290	2.20
878	-13.50	500	-1.30	300	1.70
1002	-16.30	520	-1.60	310	1.30
1091	-18.10	540	-1.90	320	1.00
1199	-20.20	560	-2.20	330	0.70
1319	-22.60	580	-2.70	340	0.40
1437	-24.90	600	-3.10	350	0.20
1553	-27.10	620	-3.90	360	-0.20
1647	-28.90	625	-6.70	370	-0.50
1759	-31.10	738	-10.70	380	-0.70
1869	-33.10	843	-16.60	390	-1.00
1971	-34.90	965	-19.10	400	-1.20
2074	-36.80	1057	-21.10	410	-1.30
2179	-38.60	1155	-23.10	420	-1.50
2270	-40.20	1232	-24.60	430	-1.60
2360	-41.80	1384	-27.60	440	-1.80
2462	-43.40	1477	-29.10	450	-2.00
2556	-45.10	1590	-31.60	460	-2.10
2659	-47.10	1682	-33.30	480	-2.50
2731	-48.30	1790	-35.30	490	-2.60

SOUTH RANGE		INDIAN CANYON RANGE		NORTH RANGE	
<u>Dist.</u> <u>Feet</u>	<u>Elev.</u> <u>Feet</u>	<u>Dist.</u> <u>Feet</u>	<u>Elev.</u> <u>Feet</u>	<u>Dist.</u> <u>Feet</u>	<u>Elev.</u> <u>Feet</u>
2846	-50.20	1885	-37.10	500	-2.70
2917	-51.60	1991	-38.70	510	-2.90
3027	-53.30	2095	-40.70	520	-3.10
3111	-54.90	2192	-42.60	530	-3.20
		2295	-44.30	540	-3.40
		2389	-45.70	550	-3.40
		2495	-47.60	560	-3.70
		2609	-49.30	570	-3.90
		2700	-50.70	580	-4.10
		2754	-51.30	590	-4.70
		2909	-53.70	600	-4.90
		3022	-55.70	610	-5.20
		3129	-57.10	620	-5.60
		3232	-58.70	630	-5.90
		3309	-60.10	685	-5.90
				793	-8.90
				934	-15.90
				1039	-18.10
				1154	-20.40
				1283	-23.10
				1436	-25.90
				1555	-28.10
				1663	-29.80
				1771	-31.60
				1899	-33.80
				2016	-35.80
				2151	-38.10
				2220	-39.30
				2340	-41.10
				2481	-44.10
				2599	-46.10
				2727	-48.30
				2833	-50.30
				2954	-52.30
				3036	-53.70
				3166	-56.10
				3288	-58.20
				3387	-60.10
Ref. Rods:		Ref. Rods:		Ref. Rods:	
1011	-16.60	816	-16.10	942	-16.10
1375	-24.10	1219	-24.10	1331	-24.00
1866	-33.00	1667	-33.00	1862	-33.00
		2343	-45.00		
		3635	-65.00		

23 October 1972

SOUTH RANGE		INDIAN CANYON RANGE		NORTH RANGE	
Dist. Feet	Elev. Feet	Dist. Feet	Elev. Feet	Dist. Feet	Elev. Feet
0	8.80	0	10.10	0	10.09
20	8.50	20	9.60	20	9.90
40	7.90	40	8.80	40	9.10
60	7.60	60	8.10	60	9.10
80	6.80	80	8.10	80	8.30
100	5.40	100	8.10	100	8.20
120	4.20	120	7.70	120	8.10
140	3.40	140	7.60	140	7.40
160	2.80	160	6.80	160	7.10
180	2.10	180	6.20	180	7.10
200	1.60	200	6.20	200	7.20
220	1.10	220	6.40	220	7.20
240	0.60	240	6.60	240	5.90
260	0.20	260	5.10	260	3.90
280	-0.40	280	4.10	280	2.60
300	-0.80	300	3.10	300	1.60
320	-1.20	320	2.60	320	1.10
340	-1.50	340	1.80	340	0.40
360	-1.80	360	1.30	360	-0.10
380	-2.10	380	0.80	380	-0.60
400	-2.20	400	0.60	400	-1.10
420	-2.40	420	0.10	420	-1.30
440	-2.50	440	-0.30	440	-1.70
459	-2.20	460	-0.70	460	-2.10
460	-2.70	480	-1.10	480	-2.40
480	-2.90	500	-1.30	500	-2.60
500	-3.00	520	-1.60	520	-2.90
520	-3.10	540	-1.80	540	-3.10
540	-3.20	560	-2.10	560	-3.40
602	-3.20	580	-2.20	580	-3.60
754	-9.20	600	-2.60	600	-3.90
910	-14.20	620	-2.70	667	-6.70
1087	-18.20	640	-2.90	830	-11.70
1250	-21.40	646	-8.00	987	-17.10
1416	-22.80	804	-16.60	1130	-20.10
1576	-27.40	959	-19.30	1282	-22.90
1728	-30.30	1130	-22.60	1402	-25.20
1911	-33.80	1292	-25.60	1517	-27.10
2080	-36.90	1446	-28.70	1625	-29.10
2205	-39.10	1598	-32.10	1764	-31.40
2338	-41.30	1749	-34.60	1840	-32.80
2412	-42.70	1888	-37.10	1997	-35.40



<u>SOUTH RANGE</u>		<u>INDIAN CANYON RANGE</u>		<u>NORTH RANGE</u>	
<u>Dist.</u> <u>Feet</u>	<u>Elev.</u> <u>Feet</u>	<u>Dist.</u> <u>Feet</u>	<u>Elev.</u> <u>Feet</u>	<u>Dist.</u> <u>Feet</u>	<u>Elev.</u> <u>Feet</u>
2489	-44.10	2037	-40.10	2191	-38.90
2585	-45.60	2180	-42.10	2302	-40.90
2665	-47.10	2343	-45.10	2420	-43.10
2711	-47.90	2518	-48.10	2564	-45.40
2771	-48.90	2662	-50.10	2734	-48.40
		2783	-52.10	2887	-51.10
		2949	-54.60	3059	-54.20
		3118	-57.20	3323	-58.80
Ref. Rods:		Ref. Rods:		Ref. Rods:	
1011	-16.80	816	-16.40	942	-16.30
1375	-24.00	1219	-24.10	1331	-24.00
1866	-33.00	1667	-33.00	1862	-33.00
		2343	-45.00		
		3635	-65.00		

21 November 1972

<u>SOUTH RANGE</u>		<u>INDIAN CANYON RANGE</u>		<u>NORTH RANGE</u>	
<u>Dist.</u> <u>Feet</u>	<u>Elev.</u> <u>Feet</u>	<u>Dist.</u> <u>Feet</u>	<u>Elev.</u> <u>Feet</u>	<u>Dist.</u> <u>Feet</u>	<u>Elev.</u> <u>Feet</u>
0	8.80	0	10.10	0	10.90
20	7.70	20	9.60	20	10.10
40	6.50	40	8.80	40	9.10
60	5.50	60	8.30	60	8.90
80	4.60	80	8.20	80	8.40
100	3.80	100	8.10	100	8.20
120	3.10	120	8.10	120	8.20
140	2.50	140	7.80	140	7.10
160	1.90	160	7.10	160	6.90
180	1.40	180	6.30	180	5.90
200	0.90	200	5.60	200	4.90
220	0.60	220	4.90	220	4.10
240	0.20	240	4.20	240	3.20
260	-0.20	260	3.60	260	2.60
280	-0.60	280	3.10	280	1.90
300	-0.90	300	2.60	300	1.20
320	-1.20	320	1.90	320	0.70
340	-1.60	340	1.40	340	0.10
360	-2.10	360	0.90	360	-0.40
380	-2.70	380	0.30	380	-0.90
400	-3.10	400	-0.20	400	-1.60
420	-3.50	420	-0.60	420	-2.10
440	-3.80	440	-1.10	440	-2.80
460	-4.30	460	-1.70	460	-3.60
480	-4.70	480	-2.30	480	-4.30
500	-4.90	500	-2.80	500	-5.20
1088	-17.20	520	-3.30	520	-5.60
1312	-22.20	540	-3.70	540	-5.60
1499	-26.10	560	-4.10	560	-5.60
1733	-30.60	580	-4.10	580	-5.60
1970	-35.10	600	-4.20	600	-5.60
2192	-38.80	835	-15.80	1190	-21.10
2378	-42.10	1031	-19.80	1306	-23.20
2617	-46.20	1245	-24.30	1494	-26.60
2785	-49.20	1426	-28.10	1637	-29.30
2927	-51.60	1632	-32.60	1802	-32.20
3173	-56.10	1837	-36.10	1967	-35.10
		2043	-40.10	2093	-37.20
		2209	-43.10	2252	-40.10
		2430	-46.60	2488	-44.10
		2591	-49.10	2585	-45.90
		2829	-53.10	2769	-49.10
		3043	-56.10	2916	-51.70
		3273	-59.60	3151	-55.70

21 November 1972 (Cont'd)

<u>SOUTH RANGE</u>		<u>INDIAN CANYON RANGE</u>		<u>NORTH RANGE</u>	
Ref. Rods:		Ref. Rods:		Ref. Rods:	
1011	-15.60	816	-15.10	942	-14.50
1375	-23.90	1219	-23.80	1331	-23.90
1866	-33.20	1667	-33.00	1862	-33.40
		2343	-45.10		
		3635	-65.00		

18 December 1972

<u>SOUTH RANGE</u>		<u>INDIAN CANYON RANGE</u>		<u>NORTH RANGE</u>	
<u>Dist.</u> <u>Feet</u>	<u>Elev.</u> <u>Feet</u>	<u>Dist.</u> <u>Feet</u>	<u>Elev.</u> <u>Feet</u>	<u>Dist.</u> <u>Feet</u>	<u>Elev.</u> <u>Feet</u>
0	8.80	0	10.10	0	10.90
20	8.00	20	9.60	20	10.10
40	6.80	40	8.80	40	9.10
60	5.60	60	8.30	60	8.90
80	4.50	80	8.20	80	8.40
100	3.70	100	8.20	100	8.20
120	3.00	120	8.10	120	8.30
140	2.50	140	7.60	140	8.10
160	1.90	160	7.20	160	7.40
180	1.30	180	6.30	180	6.60
200	0.90	200	5.30	200	5.30
220	0.60	220	4.40	220	4.30
240	0.20	240	3.60	240	3.30
260	-0.10	260	3.10	260	2.60
280	-0.30	280	2.60	280	1.70
300	-0.40	300	1.90	300	1.10
320	-0.50	320	1.40	320	0.60
340	-0.80	340	1.10	340	-0.10
360	-1.10	360	0.60	360	-0.60
380	-1.50	380	0.20	380	-1.10
400	-2.00	400	0.10	400	-1.30
420	-2.70	420	-0.30	420	-1.60
440	-3.30	440	-0.60	440	-1.80
460	-3.80	460	-0.70	460	-2.10
480	-4.30	480	-1.10	480	-2.20
500	-5.10	500	-1.60	500	-2.60
793	-11.10	520	-2.10	520	-2.90
997	-14.70	540	-2.60	540	-3.60
1175	-18.70	560	-3.20	560	-4.10
1367	-23.20	580	-3.90	580	-4.60
1563	-27.20	600	-4.70	600	-5.20
1752	-30.80	620	-5.30	620	-5.80
1939	-34.30	640	-6.10	640	-6.60
2130	-37.10	994	-18.00	660	-7.10
2305	-40.60	1057	-20.60	680	-7.60
2487	-43.90	1231	-24.10	880	-11.40
2663	-47.10	1414	-28.10	1030	-17.10
2856	-50.30	1586	-31.60	1179	-20.80
3013	-53.20	1762	-34.80	1333	-24.10
3155	-55.70	1931	-37.80	1456	-26.30
3284	-57.90	2148	-41.60	1695	-30.20
		2321	-44.80	1850	-33.10

<u>SOUTH RANGE</u>		<u>INDIAN CANYON RANGE</u>		<u>NORTH RANGE</u>	
<u>Dist.</u> <u>Feet</u>	<u>Elev.</u> <u>Feet</u>	<u>Dist.</u> <u>Feet</u>	<u>Elev.</u> <u>Feet</u>	<u>Dist.</u> <u>Feet</u>	<u>Elev.</u> <u>Feet</u>
		2469	-47.10	2043	-36.30
		2648	-50.10	2194	-39.10
		2876	-53.30	2374	-42.20
		3022	-55.80	2534	-44.90
		3237	-58.80	2712	-48.10
				2896	-51.20
				3080	-54.40
				3231	-57.10
				3413	-60.10
 Ref. Rods:		 Ref. Rods:		 Ref. Rods:	
1011	-14.80	816	-15.20	942	-14.80
1375	-23.80	1219	-23.80	1331	-23.90
1866	-33.00	1667	-33.00	1862	-33.00
		2343	-45.00		
		3635	-65.00		

17 January 1973

SOUTH RANGE		INDIAN CANYON RANGE		NORTH RANGE	
Dist. Feet	Elev. Feet	Dist. Feet	Elev. Feet	Dist. Feet	Elev. Feet
0	8.80	0	10.10	0	10.90
20	6.10	20	9.60	20	10.10
40	4.80	40	8.80	40	9.10
60	3.90	60	8.60	60	8.90
80	3.10	80	8.40	80	8.40
100	2.40	100	8.20	100	8.20
120	1.80	120	7.30	120	8.30
140	1.20	140	6.60	140	8.20
160	0.70	160	5.60	160	6.60
180	0.20	180	4.80	180	5.10
200	-0.30	200	4.10	200	3.90
220	-0.70	220	3.40	220	2.80
240	-1.10	240	2.80	240	2.10
260	-1.20	260	2.20	260	1.30
280	-1.60	280	1.70	280	0.70
300	-1.80	300	1.20	300	0.10
320	-2.10	320	0.80	320	-0.40
340	-2.40	340	0.30	340	-0.90
360	-2.60	360	0.10	360	-1.20
380	-2.80	380	-0.30	380	-1.60
400	-3.10	400	-0.60	400	-1.80
420	-3.20	420	-0.80	420	-1.90
440	-3.60	440	-1.10	440	-2.10
460	-3.90	460	-1.20	460	-2.10
480	-4.60	480	-1.40	480	-2.30
500	-5.60	500	-1.60	500	-2.70
1221	-19.80	520	-2.10	520	-3.20
1453	-24.60	540	-2.60	540	-3.90
1624	-28.10	560	-2.90	560	-4.60
1745	-30.30	580	-3.40	580	-5.30
1892	-33.40	600	-4.10	600	-6.10
2083	-36.90	620	-4.60	620	-6.90
2205	-39.10	640	-5.40	640	-7.90
2358	-41.80	660	-6.10	660	-8.90
2499	-44.10	967	-17.80	1146	-19.10
2690	-47.60	1025	-19.10	1363	-24.10
2849	-50.20	1157	-22.10	1554	-27.60
3027	-53.30	1379	-26.80	1710	-30.60
3231	-57.10	1565	-30.90	1871	-33.20
		1752	-34.60	1961	-34.90
		1879	-37.10	2171	-38.60
		2013	-39.10	2357	-41.70

17 January 1973 (Cont'd)

<u>SOUTH RANGE</u>		<u>INDIAN CANYON RANGE</u>		<u>NORTH RANGE</u>	
<u>Dist.</u> <u>Feet</u>	<u>Elev.</u> <u>Feet</u>	<u>Dist.</u> <u>Feet</u>	<u>Elev.</u> <u>Feet</u>	<u>Dist.</u> <u>Feet</u>	<u>Elev.</u> <u>Feet</u>
		2159	-42.10	2581	-45.70
		2281	-44.10	2791	-49.40
		2533	-48.10	2900	-51.20
		2817	-52.60	3101	-54.80
Ref. Rods:		Ref. Rods:		Ref. Rods:	
1011	-13.40	816	-13.00	942	-14.80
1375	-22.80	1219	-23.20	1331	-23.50
1866	-32.90	1667	-33.00	1862	-33.00
		2343	-45.00		
		3635	-65.00		

16 February 1973

<u>SOUTH RANGE</u>		<u>INDIAN CANYON RANGE</u>		<u>NORTH RANGE</u>	
<u>Dist.</u> <u>Feet</u>	<u>Elev.</u> <u>Feet</u>	<u>Dist.</u> <u>Feet</u>	<u>Elev.</u> <u>Feet</u>	<u>Dist.</u> <u>Feet</u>	<u>Elev.</u> <u>Feet</u>
0	8.80	0	10.10	0	10.90
20	5.80	20	9.70	20	10.10
40	4.60	40	9.20	40	9.10
60	3.60	60	8.10	60	8.90
80	2.90	80	6.90	80	8.80
100	2.30	100	6.30	100	8.60
120	1.70	120	5.70	120	8.60
140	1.20	140	5.10	140	5.40
160	0.70	160	4.60	160	4.60
180	0.30	180	3.90	180	3.70
200	-0.10	200	3.30	200	3.10
220	-0.60	220	2.80	220	2.30
240	-0.90	240	2.40	240	1.80
260	-1.20	260	2.10	260	1.20
280	-1.40	280	1.60	280	0.70
300	-1.80	300	1.10	300	0.30
320	-2.10	320	0.70	320	-0.20
340	-2.30	340	0.30	340	-0.60
360	-2.80	360	-0.10	360	-1.10
380	-2.10	380	-0.40	380	-1.20
400	-2.20	400	-0.70	400	-1.40
420	-2.40	420	-1.10	420	-1.60
440	-3.10	440	-1.20	440	-1.60
460	-3.80	460	-1.30	460	-1.80
480	-4.60	480	-1.30	480	-2.10
1031	-14.30	500	-1.30	500	-2.60
1223	-19.10	520	-1.40	520	-3.10
1409	-23.30	540	-1.70	540	-3.60
1619	-27.80	560	-2.60	560	-4.30
1769	-31.10	580	-3.40	580	-4.90
1975	-35.10	600	-4.10	600	-5.40
2181	-38.40	620	-4.40	620	-6.30
2333	-41.20	640	-5.10	640	-7.10
2556	-45.20	886	-16.10	1265	-21.60
2722	-48.10	1042	-19.60	1413	-24.60
2922	-51.60	1237	-24.10	1586	-28.10
3105	-54.80	1413	-28.10	1757	-31.30
		1605	-31.80	1967	-35.10
		1775	-35.10	2144	-38.10
		1943	-38.10	2323	-41.20
		2126	-41.10	2483	-44.10
		2228	-43.10	2667	-47.20



16 February 1973 (Cont'd)

<u>SOUTH RANGE</u>		<u>INDIAN CANYON RANGE</u>		<u>NORTH RANGE</u>	
<u>Dist.</u> <u>Feet</u>	<u>Elev.</u> <u>Feet</u>	<u>Dist.</u> <u>Feet</u>	<u>Elev.</u> <u>Feet</u>	<u>Dist.</u> <u>Feet</u>	<u>Elev.</u> <u>Feet</u>
		2482	-47.30	2840	-50.20
		2661	-50.10	3025	-53.60
		2822	-53.10	3211	-56.80
		2999	-55.30	3368	-59.40
		3164	-58.10		
Ref. Rods:		Ref. Rods:		Ref. Rods:	
1011	-13.40	816	-13.30	942	-14.00
1375	-22.60	1219	-22.90	1331	-22.80
1866	-33.00	1667	-33.00	1862	-33.00
		2343	-45.00		
		3635	-65.00		

16 March 1973

<u>SOUTH RANGE</u>		<u>INDIAN CANYON RANGE</u>		<u>NORTH RANGE</u>	
<u>Dist.</u> <u>Feet</u>	<u>Elev.</u> <u>Feet</u>	<u>Dist.</u> <u>Feet</u>	<u>Elev.</u> <u>Feet</u>	<u>Dist.</u> <u>Feet</u>	<u>Elev.</u> <u>Feet</u>
0	8.80	0	10.10	0	10.90
20	6.10	20	9.80	20	10.10
40	4.70	40	9.20	40	9.10
60	3.60	60	7.90	60	8.90
80	2.60	80	6.10	80	8.80
100	1.80	100	5.40	100	8.70
120	1.10	120	4.90	120	8.20
140	0.60	140	4.20	140	5.70
160	0.20	160	3.60	160	4.80
180	-0.30	180	3.10	180	3.90
200	-0.70	200	2.40	200	3.10
220	-1.10	220	1.90	220	2.20
240	-1.40	240	1.40	240	1.60
260	-1.70	260	0.90	260	1.10
280	-1.90	280	0.60	280	0.40
300	-2.10	300	0.10	300	-0.20
320	-2.20	320	-0.30	320	-0.60
340	-2.60	340	-0.60	340	-1.10
360	-3.10	360	-0.90	360	-1.30
380	-3.60	380	-1.20	380	-1.60
1132	-16.80	400	-1.60	400	-1.90
1237	-19.20	420	-2.10	420	-2.10
1411	-23.30	440	-2.60	440	-2.40
1571	-26.80	460	-2.60	460	-2.60
1725	-30.10	480	-2.80	480	-2.90
2004	-35.40	500	-2.70	500	-3.20
2076	-36.80	520	-2.60	520	-3.70
2230	-39.40	540	-3.10	540	-4.10
2406	-42.40	560	-3.70	560	-4.60
2575	-45.40	862	-15.60	580	-5.10
2741	-48.20	1007	-18.80	1114	-18.10
2927	-51.60	1144	-22.10	1336	-23.10
3100	-54.70	1276	-25.10	1491	-26.10
3275	-57.90	1412	-28.10	1637	-29.30
		1564	-31.10	1779	-31.80
		1710	-34.10	1903	-33.80
		1865	-36.60	2000	-35.60
		2012	-39.30	2130	-37.90
		2156	-41.70	2248	-39.90
		2310	-44.10	2372	-42.10
		2449	-46.90	2531	-44.90
		2599	-49.10	2669	-47.30

16 March 1973 (Cont'd)

<u>SOUTH RANGE</u>		<u>INDIAN CANYON RANGE</u>		<u>NORTH RANGE</u>	
<u>Dist.</u> <u>Feet</u>	<u>Elev.</u> <u>Feet</u>	<u>Dist.</u> <u>Feet</u>	<u>Elev.</u> <u>Feet</u>	<u>Dist.</u> <u>Feet</u>	<u>Elev.</u> <u>Feet</u>
		2739	-51.30	2823	-50.10
		2876	-53.60	2958	-52.30
		3020	-55.70	3118	-55.10
		3191	-58.30	3231	-57.10
		3318	-60.10	3409	-60.10
Ref. Rods:		Ref. Rods:		Ref. Rods:	
1011	-13.80	816	-14.20	942	-13.80
1375	-22.60	1219	-22.80	1331	-22.70
1866	-32.90	1667	-32.90	1862	-33.00
		2343	-45.00		
		3625	-65.00		

11 April 1973

<u>SOUTH RANGE</u>		<u>INDIAN CANYON RANGE</u>		<u>NORTH RANGE</u>	
<u>Dist.</u> <u>Feet</u>	<u>Elev.</u> <u>Feet</u>	<u>Dist.</u> <u>Feet</u>	<u>Elev.</u> <u>Feet</u>	<u>Dist.</u> <u>Feet</u>	<u>Elev.</u> <u>Feet</u>
0	8.80	0	10.10	0	10.90
20	6.30	20	9.60	20	10.10
40	5.60	40	9.10	40	9.10
60	4.30	60	7.70	60	9.10
80	3.30	80	6.10	80	8.80
100	2.30	100	5.40	100	8.60
120	1.60	120	5.10	120	7.30
140	0.90	140	4.70	140	6.10
160	0.30	160	4.60	160	5.10
180	-0.10	180	4.10	180	4.10
200	-0.60	200	3.20	200	3.40
220	-0.60	220	2.10	220	2.70
240	-0.90	240	1.30	240	2.10
260	-1.20	260	0.70	260	1.10
280	-1.40	280	0.20	280	0.40
300	-1.90	300	-0.10	300	-0.20
320	-2.60	320	-0.30	320	-0.80
340	-2.90	340	-0.30	340	-1.30
360	-3.60	360	-0.60	360	-1.80
380	-4.30	380	-1.10	380	-2.10
400	-4.90	400	-2.10	400	-2.60
420	-5.10	420	-1.90	420	-2.90
440	-5.30	440	-1.70	440	-3.20
1008	-14.20	460	-1.60	460	-3.60
1169	-17.80	480	-1.60	480	-3.90
1334	-21.60	500	-1.60	500	-4.60
1499	-25.20	520	-1.80	520	-4.60
1656	-28.70	540	-2.20	540	-5.10
1827	-32.10	560	-2.60	560	-6.10
1989	-35.20	580	-3.10	1022	-16.10
2171	-38.30	600	-3.70	1202	-20.10
2321	-41.10	620	-4.60	1375	-23.90
2493	-44.10	640	-5.20	1539	-27.10
2630	-46.40	660	-6.10	1699	-30.30
2785	-49.10	839	-15.10	1873	-33.30
2930	-51.70	1013	-19.10	2030	-36.30
3063	-54.10	1179	-22.60	2212	-39.30
3197	-56.30	1334	-26.10	2368	-42.30
3339	-58.90	1529	-30.30	2521	-44.70
		1698	-33.70	2696	-47.70
		1871	-36.70	2877	-50.70
		2013	-39.30	3038	-53.70

11 April 1973 (Cont'd)

<u>SOUTH RANGE</u>		<u>INDIAN CANYON RANGE</u>		<u>NORTH RANGE</u>	
<u>Dist.</u> <u>Feet</u>	<u>Elev.</u> <u>Feet</u>	<u>Dist.</u> <u>Feet</u>	<u>Elev.</u> <u>Feet</u>	<u>Dist.</u> <u>Feet</u>	<u>Elev.</u> <u>Feet</u>
		2207	-42.80	3182	-56.30
		2353	-45.30	3401	-60.10
		2516	-47.90		
		2711	-50.90		
		2866	-53.10		
		3022	-55.60		
		3240	-59.10		
		3365	-60.90		
Ref. Rods:		Ref. Rods:		Ref. Rods:	
1011	-13.80	816	-14.40	942	-14.20
1375	-22.80	1219	-22.80	1351	-22.80
1866	-32.90	1667	-32.90	1862	-33.00
		2343	-45.00		
		3635	-65.00		

11 May 1973

<u>SOUTH RANGE</u>		<u>INDIAN CANYON RANGE</u>		<u>NORTH RANGE</u>	
<u>Dist.</u> <u>Feet</u>	<u>Elev.</u> <u>Feet</u>	<u>Dist.</u> <u>Feet</u>	<u>Elev.</u> <u>Feet</u>	<u>Dist.</u> <u>Feet</u>	<u>Elev.</u> <u>Feet</u>
0	8.80	0	10.10	0	10.90
20	5.70	20	9.70	20	10.10
40	4.80	40	9.10	40	9.10
60	4.20	60	7.90	60	8.90
80	3.40	80	6.40	80	8.80
100	2.90	100	6.10	100	8.60
120	1.30	120	6.10	120	7.70
140	0.60	140	5.90	140	6.20
160	-0.20	160	5.20	160	5.40
180	-0.70	180	4.60	180	4.20
200	-1.10	200	4.10	200	3.60
220	-1.40	220	3.20	220	2.70
240	-1.40	240	2.40	240	1.70
260	-1.60	260	1.80	260	0.80
280	-1.70	280	1.30	280	0.10
300	-1.90	300	0.80	300	-0.60
320	-2.10	320	0.40	320	-1.10
340	-2.10	340	0.10	340	-1.60
360	-2.20	360	-0.30	360	-1.90
380	-2.60	380	-0.60	380	-2.20
400	-2.80	400	-0.80	400	-2.30
420	-3.10	420	-1.10	420	-2.40
440	-3.40	440	-1.30	440	-2.70
460	-3.80	460	-1.60	460	-3.10
853	-11.80	480	-1.80	480	-3.30
1045	-14.80	500	-2.60	500	-4.30
1248	-19.60	520	-2.30	520	-3.40
1469	-24.60	540	-2.60	540	-3.80
1662	-28.70	560	-3.10	560	-3.80
1860	-32.80	580	-3.60	580	-4.10
2064	-36.60	600	-3.90	600	-4.60
2252	-39.80	682	-8.00	795	-10.10
2452	-43.30	862	-15.60	970	-14.60
2841	-50.10	1057	-20.10	1101	-17.80
3018	-53.20	1246	-24.10	1242	-21.10
3206	-56.60	1407	-27.40	1375	-23.90
3352	-59.10	1588	-31.60	1510	-26.40
		1770	-35.10	1647	-29.40
		1958	-38.30	1785	-31.70
		2139	-41.60	1931	-34.20
		2323	-44.90	2082	-36.90
		2503	-47.80	2230	-39.40

11 May 1973 (Cont'd)

<u>SOUTH RANGE</u>		<u>INDIAN CANYON RANGE</u>		<u>NORTH RANGE</u>	
<u>Dist.</u> <u>Feet</u>	<u>Elev.</u> <u>Feet</u>	<u>Dist.</u> <u>Feet</u>	<u>Elev.</u> <u>Feet</u>	<u>Dist.</u> <u>Feet</u>	<u>Elev.</u> <u>Feet</u>
		2702	-50.90	2380	-42.10
		2871	-53.10	2522	-44.40
		3070	-56.30	2667	-47.10
		3208	-58.60	2769	-48.90
				2892	-51.10
				3050	-53.80
				3166	-55.80
				3334	-58.80
Ref. Rods:		Ref. Rods:		Ref. Rods:	
1011	-13.60	816	-14.00	942	-14.00
1375	-22.80	1219	-22.80	1331	-22.80
1866	-32.80	1667	-32.90	1862	-33.00
		2343	-45.00		
		3635	-65.00		

6 June 1973

SOUTH RANGE		INDIAN CANYON RANGE		NORTH RANGE	
<u>Dist.</u>	<u>Elev.</u>	<u>Dist.</u>	<u>Elev.</u>	<u>Dist.</u>	<u>Elev.</u>
0	8.80	0	10.10	0	10.90
20	7.20	20	9.70	20	10.10
40	6.60	40	9.10	40	9.20
60	5.60	60	8.10	60	8.90
80	4.40	80	6.40	80	8.80
100	3.40	100	6.30	100	8.40
120	2.40	120	6.40	120	7.60
140	1.60	140	6.40	140	6.20
160	0.90	160	6.10	160	5.80
180	0.10	180	5.60	180	4.90
200	-0.60	200	4.80	200	3.90
220	-1.20	220	3.90	220	3.10
240	-1.40	240	3.40	240	2.20
260	-0.80	260	2.60	260	1.40
280	-0.60	280	1.90	280	0.80
300	-0.80	300	1.60	300	0.40
320	-1.10	320	1.30	320	0.10
340	-1.30	340	0.90	340	-0.20
360	-1.80	360	0.60	360	-0.60
380	-2.20	380	0.20	380	-0.90
400	-2.60	400	0.10	400	-1.20
420	-3.10	420	-0.20	420	-1.40
440	-3.60	440	-0.40	440	-1.70
460	-3.90	460	-0.70	460	-1.90
510	-6.90	480	-0.80	480	-2.20
687	-10.90	500	-1.30	500	-2.70
875	-13.90	520	-2.10	520	-3.40
1032	-15.90	540	-2.80	540	-4.10
1177	-18.90	560	-3.20	560	-4.60
1345	-22.60	580	-3.80	580	-5.20
1512	-25.80	704	-11.70	600	-5.60
1692	-29.20	999	-19.20	620	-8.00
1879	-33.30	1147	-22.20	812	-10.30
2070	-36.80	1407	-27.60	1011	-16.30
2226	-39.30	1593	-31.70	1194	-20.10
2421	-42.90	1792	-35.20	1357	-23.40
2515	-44.60	1991	-38.90	1510	-26.30
2781	-49.10	2212	-42.90	1697	-29.70
2930	-51.80	2394	-46.10	1835	-32.80
3310	-58.30	2609	-49.30	1943	-34.60
		2820	-52.70	2211	-30.40



6 June 1973 (Cont'd)

<u>SOUTH RANGE</u>		<u>INDIAN CANYON RANGE</u>		<u>NORTH RANGE</u>	
<u>Dist.</u> <u>Feet</u>	<u>Elev.</u> <u>Feet</u>	<u>Dist.</u> <u>Feet</u>	<u>Elev.</u> <u>Feet</u>	<u>Dist.</u> <u>Feet</u>	<u>Elev.</u> <u>Feet</u>
		2820	-52.70	2388	-42.40
				2554	-45.30
				2745	-48.70
				2966	-52.40
				3157	-55.80
				3358	-59.40
Ref. Rods:		Ref. Rods:		Ref. Rods:	
1011	-13.80	816	-14.60	942	-14.60
1375	-22.80	1219	-22.80	1331	-22.90
1866	-32.90	1667	-32.90	1862	-33.00
		2343	-44.90		
		3635	-65.00		

5 July 1973

<u>SOUTH RANGE</u>		<u>INDIAN CANYON RANGE</u>		<u>NORTH RANGE</u>	
<u>Dist.</u> <u>Feet</u>	<u>Elev.</u> <u>Feet</u>	<u>Dist.</u> <u>Feet</u>	<u>Elev.</u> <u>Feet</u>	<u>Dist.</u> <u>Feet</u>	<u>Elev.</u> <u>Feet</u>
0	8.80	0	10.10	0	10.90
20	7.90	20	9.70	20	10.10
40	7.30	40	9.10	40	9.10
60	6.10	60	7.80	60	9.10
80	4.80	80	6.40	80	8.70
100	3.60	100	6.40	100	8.40
120	2.20	120	6.60	120	7.30
140	1.30	140	6.70	140	6.30
160	0.60	160	6.90	160	6.30
180	0.20	180	6.80	180	6.20
200	-0.20	200	6.20	200	5.10
220	-0.60	220	5.30	220	4.10
240	-0.80	240	4.60	240	3.30
260	-1.10	260	2.90	260	2.10
280	-1.40	280	1.60	280	0.80
300	-1.80	300	0.90	300	0.10
320	-2.10	320	0.60	320	-0.60
340	-2.40	340	0.10	340	-0.80
360	-2.90	360	-0.40	360	-1.20
664	-8.00	380	-0.70	380	-1.60
887	-12.00	400	-0.90	400	-1.80
1102	-17.20	420	-1.20	420	-2.20
1306	-21.70	440	-1.70	440	-2.60
1501	-25.60	460	-2.10	460	-2.90
1698	-29.30	480	-2.40	480	-3.20
1887	-33.40	500	-2.60	500	-3.80
2092	-37.10	520	-3.10	520	-3.80
2301	-40.60	540	-3.60	540	-4.10
2475	-43.90	560	-4.10	560	-4.40
2720	-47.90	507	-3.00	580	-4.70
2874	-50.70	702	-9.00	600	-5.10
3170	-55.90	580	-4.30	801	-8.50
		892	-17.20	949	-15.10
		1062	-20.20	1110	-18.30
		1259	-24.10	1268	-21.60
		1498	-29.40	1477	-25.80
		1653	-32.90	1697	-30.40
		1833	-36.10	1866	-33.20
		2022	-39.60	2083	-37.10
		2206	-42.80	2266	-40.20
		2384	-45.90	2452	-43.40
		2581	-48.90	2647	-48.70
		2768	-51.80	2823	-50.10

5 July 1973 (Cont'd)

<u>SOUTH RANGE</u>		<u>INDIAN CANYON RANGE</u>		<u>NORTH RANGE</u>	
<u>Dist.</u> <u>Feet</u>	<u>Elev.</u> <u>Feet</u>	<u>Dist.</u> <u>Feet</u>	<u>Elev.</u> <u>Feet</u>	<u>Dist.</u> <u>Feet</u>	<u>Elev.</u> <u>Feet</u>
		2964	-54.80	3044	-53.80
		3105	-56.90	3215	-56.80
Ref. Rods:		Ref. Rods:		Ref. Rods:	
1011	-15.10	816	-15.70	942	-15.30
1375	-22.80	1219	-23.10	1331	-22.90
1866	-32.90	1667	-32.90	1862	-33.00
		2343	-45.00		
		3635	-65.00		

27 August 1973

SOUTH RANGE		INDIAN CANYON RANGE		NORTH RANGE	
Dist. Feet	Elev. Feet	Dist. Feet	Elev. Feet	Dist. Feet	Elev. Feet
0	8.80	0	10.10	0	10.90
20	7.90	20	9.60	20	10.10
40	7.70	40	9.10	40	9.20
60	7.40	60	7.90	60	8.90
80	6.80	80	6.40	80	8.80
100	5.80	100	6.30	100	8.60
120	4.60	120	6.60	120	7.70
140	3.60	140	6.60	140	6.40
160	2.60	160	7.10	160	6.30
180	1.80	180	7.30	180	6.40
200	1.20	200	7.80	200	6.20
220	0.80	220	8.10	220	5.40
240	0.30	240	5.40	240	4.60
260	-0.30	260	3.80	260	3.40
280	-0.80	280	2.60	280	2.30
300	-1.20	300	1.60	300	1.40
320	-1.60	320	1.10	320	0.60
340	-1.90	340	0.70	340	0.10
360	-2.10	360	0.10	360	-0.40
380	-2.60	380	-0.60	380	-0.70
400	-2.80	400	-1.20	400	-1.10
420	-3.10	420	-1.60	420	-1.60
440	-3.10	440	-1.90	440	-2.20
460	-4.10	460	-2.20	460	-2.60
480	-4.10	480	-2.30	480	-3.60
966	-14.40	500	-2.60	500	-4.20
1153	-18.20	520	-2.60	520	-5.10
1345	-22.30	540	-2.70	540	-5.60
1541	-26.20	560	-2.90	560	-5.90
1725	-29.80	580	-3.10	580	-6.30
1903	-33.60	623	-6.00	600	-6.90
2132	-37.80	825	-16.70	620	-7.60
2291	-40.40	1021	-19.90	1081	-18.40
2475	-43.90	1211	-23.10	1262	-21.60
2661	-46.90	1403	-27.10	1439	-25.10
2839	-50.10	1606	-31.80	1665	-29.80
3029	-53.30	1793	-35.20	1871	-33.20
3222	-57.10	1988	-38.80	2070	-36.80
		2192	-42.60	2291	-40.60
		2405	-46.20	2486	-44.20
		2593	-49.10	2699	-48.10
		2806	-52.30	2881	-50.90
		2997	-55.20	3144	-55.40

27 August 1973 (Cont'd)

<u>SOUTH RANGE</u>		<u>INDIAN CANYON RANGE</u>		<u>NORTH RANGE</u>	
<u>Dist.</u> <u>Feet</u>	<u>Elev.</u> <u>Feet</u>	<u>Dist.</u> <u>Feet</u>	<u>Elev.</u> <u>Feet</u>	<u>Dist.</u> <u>Feet</u>	<u>Elev.</u> <u>Feet</u>
		3168	-57.90		
		3381	-61.20		
Ref. Rods:		Ref. Rods:		Ref. Rods:	
1011	-15.70	816	-16.50	942	-15.90
1375	-22.80	1219	-23.10	1331	-22.90
1866	-32.80	1667	-32.90	1862	-33.00
		2343	-45.00		
		3635	-65.00		

28 September 1973

<u>SOUTH RANGE</u>		<u>INDIAN CANYON RANGE</u>		<u>NORTH RANGE</u>	
<u>Dist.</u> <u>Feet</u>	<u>Elev.</u> <u>Feet</u>	<u>Dist.</u> <u>Feet</u>	<u>Elev.</u> <u>Feet</u>	<u>Dist.</u> <u>Feet</u>	<u>Elev.</u> <u>Feet</u>
0	8.80	0	10.10	0	10.90
20	7.90	20	10.10	20	10.10
40	7.70	40	9.60	40	9.20
60	7.30	60	8.40	60	9.10
80	7.10	80	6.90	80	9.10
100	6.60	100	6.80	100	8.70
120	4.90	120	6.90	120	8.40
140	3.40	140	7.20	140	6.80
160	2.30	160	7.60	160	6.60
180	1.60	180	7.80	180	6.80
200	0.80	200	8.20	200	6.60
220	0.20	220	7.60	220	6.10
240	-0.30	240	6.90	240	5.20
260	-0.60	260	5.10	260	4.10
280	-1.10	280	3.60	280	3.10
300	-1.30	300	2.60	300	2.10
320	-1.80	320	1.80	320	1.20
340	-1.80	340	1.10	340	0.60
360	-1.90	360	0.60	360	-0.10
380	-2.30	380	0.10	380	-0.60
400	-2.60	400	-0.40	400	-1.10
420	-2.80	420	-0.60	420	-1.60
440	-3.40	440	-0.70	440	-1.70
460	-4.10	460	-0.90	460	-2.10
480	-4.60	480	-1.20	480	-2.20
500	-4.60	500	-1.60	500	-2.60
520	-4.30	520	-1.90	520	-2.80
540	-4.40	540	-3.60	540	-3.10
560	-4.60	560	-2.80	560	-3.30
698	-8.00	580	-2.40	580	-3.70
830	-12.00	600	-2.60	1054	-18.70
967	-15.00	758	-11.00	1162	-20.60
1112	-18.20	894	-18.90	1292	-22.80
1249	-20.80	1047	-21.10	1447	-25.30
1401	-23.60	1194	-23.40	1593	-28.10
1541	-26.30	1356	-26.60	1728	-30.60
1686	-29.30	1510	-29.60	1841	-32.60
1813	-31.60	1656	-32.70	1995	-35.30
1947	-34.20	1806	-35.30	2161	-38.20
2082	-36.80	1958	-38.20	2315	-40.90
2202	-38.80	2085	-40.60	2412	-42.70
2353	-41.40	2223	-43.10	2539	-45.10
2489	-44.10	2504	-47.60	2649	-47.10

28 September 1973 (Cont'd)

<u>SOUTH RANGE</u>		<u>INDIAN CANYON RANGE</u>		<u>NORTH RANGE</u>	
<u>Dist.</u> <u>Feet</u>	<u>Elev.</u> <u>Feet</u>	<u>Dist.</u> <u>Feet</u>	<u>Elev.</u> <u>Feet</u>	<u>Dist.</u> <u>Feet</u>	<u>Elev.</u> <u>Feet</u>
2607	-46.10	2667	-50.10	2785	-49.30
2736	-48.10	2790	-52.10	2873	-50.70
2876	-50.40	2885	-53.40	2960	-52.10
2991	-52.40	2991	-55.10		
3146	-55.40				
3262	-58.10				
Ref. Rods:		Ref. Rods:		Ref. Rods:	
1011	-16.20	816	-16.70	942	-16.40
1375	-23.20	1219	-23.50	1331	-23.10
1866	-32.90	1667	-32.90	1862	-33.00
		2343	-45.00		
		3635	-65.00		

25 October 1973

<u>SOUTH RANGE</u>		<u>INDIAN CANYON RANGE</u>		<u>NORTH RANGE</u>	
<u>Dist.</u> <u>Feet</u>	<u>Elev.</u> <u>Feet</u>	<u>Dist.</u> <u>Feet</u>	<u>Elev.</u> <u>Feet</u>	<u>Dist.</u> <u>Feet</u>	<u>Elev.</u> <u>Feet</u>
0	8.80	0	10.10	0	10.90
20	7.80	20	9.60	20	10.20
40	7.70	40	9.10	40	9.30
60	7.60	60	8.10	60	9.10
80	7.30	80	6.60	80	8.90
100	6.40	100	6.40	100	8.80
120	5.10	120	6.40	120	7.80
140	3.70	140	6.70	140	6.60
160	2.70	160	7.10	160	6.60
180	1.90	180	7.30	180	6.60
200	1.20	200	7.60	200	6.40
220	0.60	220	8.10	220	6.10
240	-0.10	240	6.70	240	4.80
260	-0.60	260	4.80	260	3.70
280	-1.10	280	3.60	280	2.80
300	-1.40	300	2.60	300	2.10
320	-1.70	320	1.70	320	1.30
340	-2.10	340	1.10	340	0.70
360	-2.40	360	0.60	360	0.10
380	-2.70	380	-0.10	380	-0.40
400	-2.90	400	-0.60	400	-0.80
420	-2.80	420	-0.90	420	-1.10
440	-3.10	440	-1.20	440	-1.60
460	-3.20	460	-1.60	460	-1.90
480	-3.20	480	-1.80	480	-2.30
500	-3.30	500	-2.10	500	-2.60
520	-3.60	520	-2.40	520	-2.80
540	-3.60	540	-2.60	540	-3.10
560	-3.90	560	-3.20	560	-3.30
975	-14.70	580	-3.40	580	-3.40
1085	-17.40	600	-3.60	600	-3.60
1209	-20.10	620	-3.60	620	-3.60
1342	-22.30	778	-12.00	640	-3.80
1474	-25.10	898	-18.90	660	-4.10
1579	-27.10	1062	-21.30	680	-4.40
1736	-30.10	1200	-23.40	700	-4.60
1873	-32.70	1342	-26.30	720	-5.10
1998	-35.20	1479	-28.90	740	-5.60
2130	-37.70	1620	-31.80	760	-6.10
2263	-39.90	1745	-34.20	780	-6.60
2399	-42.30	1869	-36.40	1219	-21.40
2527	-44.80	2000	-38.90	1393	-24.60
2624	-46.30	2136	-41.20	1540	-27.10
2759	-48.40	2294	-44.10	1653	-29.10



25 October 1973 (Cont'd)

<u>SOUTH RANGE</u>		<u>INDIAN CANYON RANGE</u>		<u>NORTH RANGE</u>	
<u>Dist.</u> <u>Feet</u>	<u>Elev.</u> <u>Feet</u>	<u>Dist.</u> <u>Feet</u>	<u>Elev.</u> <u>Feet</u>	<u>Dist.</u> <u>Feet</u>	<u>Elev.</u> <u>Feet</u>
		2424	-46.20	1835	-32.60
		2570	-48.80	2040	-36.10
		2717	-50.80	2181	-38.60
		2855	-52.90	2396	-42.30
		3002	-55.20	2551	-45.30
		3146	-57.20	2665	-47.20
		3255	-58.70	2896	-51.10
		3088	-56.60	2970	-52.30
		3200	-58.20	3166	-55.60
		3291	-59.10	3108	-54.70
				3247	-57.10
Ref. Rods:		Ref. Rods:		Ref. Rods:	
1011	-16.20	816	-16.70	942	-16.40
1375	-23.10	1219	-23.50	1331	-23.10
1866	-32.90	1667	-32.90	1862	-33.00
		2343	-45.00		
		3635	-65.00		

28 November, 1973

<u>SOUTH RANGE</u>		<u>INDIAN CANYON RANGE</u>		<u>NORTH RANGE</u>	
<u>Dist.</u>	<u>Elev.</u>	<u>Dist.</u>	<u>Elev.</u>	<u>Dist.</u>	<u>Elev.</u>
<u>Feet</u>	<u>Feet</u>	<u>Feet</u>	<u>Feet</u>	<u>Feet</u>	<u>Feet</u>
0	8.80	0	10.10	0	10.90
20	7.90	20	9.40	20	9.90
40	7.90	40	9.10	40	9.20
60	7.90	60	7.80	60	8.90
80	6.60	80	6.20	80	8.80
100	5.10	100	6.20	100	8.60
120	4.70	120	6.20	120	7.90
140	2.60	140	6.40	140	6.40
160	1.60	160	6.80	160	6.30
180	0.70	180	7.10	180	6.60
200	0.20	200	7.60	200	6.60
220	-0.40	220	7.90	220	5.10
240	-0.70	240	5.70	240	3.80
260	-1.10	260	4.10	260	2.70
280	-1.10	280	2.40	280	1.70
300	-1.20	300	1.10	300	0.80
320	-1.60	320	0.30	320	0.10
340	-2.30	340	-0.10	340	-0.60
360	-3.20	360	-0.10	360	-1.10
1024	-15.70	380	-0.20	380	-1.60
1215	-20.10	400	-0.20	400	-1.90
1381	-22.80	420	-1.20	420	-2.20
1551	-26.20	440	-1.40	440	-2.60
1713	-29.30	460	-1.60	460	-2.80
1894	-32.90	480	-1.80	480	-2.90
2068	-36.20	500	-2.10	500	-3.10
2241	-39.30	520	-2.40	520	-3.40
2425	-42.60	958	-19.60	1124	-18.90
2569	-45.10	1106	-21.80	1268	-22.10
2769	-48.30	1253	-24.30	1373	-24.10
2933	-51.10	1399	-27.20	1506	-26.20
3080	-53.60	1537	-29.90	1644	-28.80
		1716	-33.40	1781	-31.30
		1868	-36.20	1897	-33.60
		2024	-39.10	2010	-35.60
		2177	-41.80	2174	-38.30
		2310	-44.30	2315	-40.80
		2433	-46.20	2436	-43.10
		2579	-48.70	2564	-45.40
		2702	-50.60	2646	-46.80
		2838	-52.60	2735	-48.30
		2984	-54.90	2821	-49.70
		3096	-56.60	2910	-51.20
		3237	-58.60	3007	-52.90

28 November 1973 (Cont'd)

<u>SOUTH RANGE</u>		<u>INDIAN CANYON RANGE</u>		<u>NORTH RANGE</u>	
<u>Dist.</u> <u>Feet</u>	<u>Elev.</u> <u>Feet</u>	<u>Dist.</u> <u>Feet</u>	<u>Elev.</u> <u>Feet</u>	<u>Dist.</u> <u>Feet</u>	<u>Elev.</u> <u>Feet</u>
		3387	-60.60	3112	-54.60
				3274	-57.20
Ref. Rods:		Ref. Rods:		Ref. Rods:	
1011	-16.50	816	-16.90	942	-15.30
1375	-23.30	1219	-23.50	1331	-23.20
1866	-32.90	1667	-32.90	1862	-33.00
		2343	-45.00		
		3635	-65.00		

4 December 1973

<u>SOUTH RANGE</u>		<u>INDIAN CANYON RANGE</u>		<u>NORTH RANGE</u>	
<u>Dist.</u> <u>Feet</u>	<u>Elev.</u> <u>Feet</u>	<u>Dist.</u> <u>Feet</u>	<u>Elev.</u> <u>Feet</u>	<u>Dist.</u> <u>Feet</u>	<u>Elev.</u> <u>Feet</u>
0	8.80	0	10.10	0	10.90
20	7.90	20	9.30	20	10.10
40	7.90	40	8.80	40	9.20
60	7.90	60	7.70	60	8.90
80	6.40	80	6.30	80	8.80
100	5.40	100	6.20	100	8.60
120	4.10	120	6.30	120	7.90
140	2.90	140	6.60	140	6.30
160	2.10	160	6.90	160	6.30
180	1.10	180	7.20	180	6.60
200	0.40	200	7.70	200	6.70
220	-0.20	220	8.10	220	5.30
240	-0.70	240	5.40	240	4.20
260	-1.20	260	3.70	260	3.10
280	-1.70	280	2.40	280	2.10
		300	1.60	300	1.20
		320	0.70	320	0.60
		340	-0.10	340	-0.20
		360	-0.80	360	-0.90
		380	-1.30	380	-1.40
		400	-2.20	400	-1.90

17 December '1973

SOUTH RANGE		INDIAN CANYON RANGE		NORTH RANGE	
Dist. Feet	Elev. Feet	Dist. Feet	Elev. Feet	Dist. Feet	Elev. Feet
0	8.80	0	10.10	0	10.90
20	8.40	20	9.60	20	10.10
40	7.80	40	8.90	40	9.20
60	6.60	60	7.70	60	8.90
62	6.60	80	6.60	80	8.80
64	5.70	100	6.60	100	8.60
80	4.90	120	7.10	120	8.10
100	3.80	140	7.40	140	6.60
120	3.10	160	7.60	160	6.60
140	2.10	180	7.80	180	6.80
160	1.40	200	8.10	200	6.90
180	0.80	215	7.60	220	6.60
200	0.20	217	6.70	240	5.10
220	-0.40	220	6.30	260	3.60
240	-0.90	240	4.30	280	2.30
260	-1.60	260	2.70	300	1.40
280	-1.80	280	1.70	320	0.60
300	-3.10	300	0.90	340	-0.10
320	-3.80	320	0.30	360	-0.60
1082	-16.80	340	-0.30	380	-1.40
1166	-18.70	360	-0.90	400	-1.80
1373	-22.40	380	-1.40	420	-2.40
1500	-25.10	400	-1.80	440	-2.90
1664	-28.20	420	-2.10	460	-3.20
1812	-31.10	1082	-21.10	480	-3.60
1935	-33.60	1236	-23.80	500	-3.90
2112	-36.80	1360	-25.70	1132	-18.80
2258	-39.60	1480	-28.70	1196	-20.40
2410	-42.10	1616	-31.20	1247	-21.70
2554	-44.60	1796	-34.60	1330	-23.10
2729	-47.40	1978	-38.10	1470	-25.40
2834	-49.20	2122	-40.60	1640	-28.60
2962	-51.30	2212	-42.20	1814	-31.80
		2343	-44.70	1950	-34.30
		2473	-46.80	2090	-36.70
		2585	-48.60	2227	-39.10
		2702	-50.30	2412	-42.40
		2941	-54.10	2576	-45.30
				2724	-47.90
				2852	-50.10
				2964	-51.90
				3095	-54.10

17 December 1973 (Cont'd)

<u>SOUTH RANGE</u>		<u>INDIAN CANYON RANGE</u>		<u>NORTH RANGE</u>	
<u>Dist.</u> <u>Feet</u>	<u>Elev.</u> <u>Feet</u>	<u>Dist.</u> <u>Feet</u>	<u>Elev.</u> <u>Feet</u>	<u>Dist.</u> <u>Feet</u>	<u>Elev.</u> <u>Feet</u>
Ref. Rods:		Ref. Rods:		Ref. Rods:	
1011	-16.10	816	-15.20	942	-14.50
1375	-23.60	1219	-23.80	1331	-23.60
1866	-33.00	1667	-32.80	1862	-33.00
		2343	-45.00		
		3635	-65.00		

10 January 1974

SOUTH RANGE		INDIAN CANYON RANGE		NORTH RANGE	
Dist. Feet	Elev. Feet	Dist. Feet	Elev. Feet	Dist. Feet	Elev. Feet
0	8.80	0	10.10	0	10.90
20	5.80	20	9.60	20	10.10
40	4.60	40	9.20	40	9.20
60	3.60	60	7.70	60	8.90
80	2.80	80	6.90	80	8.80
100	2.30	100	6.60	100	8.60
120	1.80	120	6.10	120	7.30
140	1.40	140	5.60	140	6.60
160	1.10	160	4.70	160	5.60
180	0.60	180	4.10	180	4.60
200	0.10	200	3.60	200	3.70
220	-0.60	220	3.10	220	2.70
240	-1.10	240	2.60	240	2.10
260	-1.80	260	2.20	260	1.60
280	-2.90	280	1.80	280	1.10
300	-4.10	300	1.40	300	0.60
320	-2.90	320	1.10	320	0.10
340	-2.10	340	0.60	340	-0.60
360	-1.90	360	0.20	360	-0.90
380	-2.10	380	-0.40	380	-1.30
400	-2.30	400	-1.10	400	-1.60
		420	-1.90	420	-1.80
		440	-3.10	440	-2.10
		460	-3.90	460	-2.30
				480	-2.30
				500	-2.40
				520	-2.80
				540	-3.10

22 January 1974

SOUTH RANGE		INDIAN CANYON RANGE		NORTH RANGE	
Dist. Feet	Elev. Feet	Dist. Feet	Elev. Feet	Dist. Feet	Elev. Feet
0	8.80	0	10.10	0	10.90
20	6.40	20	9.60	20	10.10
40	5.10	40	9.10	40	9.10
60	3.90	60	7.60	60	8.80
80	2.80	80	7.10	80	8.70
100	2.10	100	6.60	100	8.60
120	1.60	120	6.10	120	7.70
140	1.10	140	5.30	140	7.10
160	0.60	160	4.60	160	6.10
180	0.10	180	3.90	180	5.10
200	-0.40	200	3.30	200	4.10
220	-0.80	220	2.70	220	3.10
240	-1.20	240	2.20	240	2.10
260	-1.60	260	1.60	260	1.30
280	-1.90	280	1.20	280	0.70
300	-2.40	300	0.80	300	0.20
320	-2.70	320	0.30	320	-0.20
340	-3.10	340	0.10	340	-0.70
360	-3.20	360	-0.40	360	-1.10
380	-3.40	380	-0.70	380	-1.60
400	-3.80	400	-1.10	400	-1.90
1034	-15.90	420	-1.30	420	-2.20
1167	-18.80	440	-1.70	440	-2.60
1314	-22.30	460	-2.20	460	-2.90
1428	-24.60	480	-2.40	480	-3.20
1560	-27.10	847	-12.40	500	-3.40
1668	-29.30	996	-19.10	732	-8.40
1779	-31.30	1130	-22.00	896	-10.90
1900	-33.70	1266	-25.00	1055	-18.20
2025	-35.90	1394	-27.80	1203	-21.30
2157	-38.20	1543	-30.80	1339	-24.00
2284	-40.30	1676	-33.20	1487	-26.60
2429	-42.90	1812	-35.80	1655	-29.50
2571	-45.30	1957	-38.30	1737	-30.80
2686	-47.30	2098	-40.90	1867	-33.10
2764	-48.80	2221	-43.10	2111	-37.40
2881	-50.80	2363	-45.50	2309	-41.00
		2510	-47.80	2496	-44.20
				2654	-47.00
				2819	-49.90
				2958	-52.30



22 January (Cont'd)

SOUTH RANGE

Dist.      Elev.  
Feet      Feet

Ref. Rods:

1011      -14.80  
1375      -23.70  
1866      -33.00

INDIAN CANYON RANGE

Dist.      Elev.  
Feet      Feet

Ref. Rods:

816      -15.70  
1219      -24.00  
1667      -32.80  
2343      -45.00  
3635      -65.00

NORTH RANGE

Dist.      Elev.  
Feet      Feet

Ref. Rods:

942      -14.20  
1331      -23.60  
1862      -32.90

21 February 1974

<u>SOUTH RANGE</u>		<u>INDIAN CANYON RANGE</u>		<u>NORTH RANGE</u>	
<u>Dist.</u> <u>Feet</u>	<u>Elev.</u> <u>Feet</u>	<u>Dist.</u> <u>Feet</u>	<u>Elev.</u> <u>Feet</u>	<u>Dist.</u> <u>Feet</u>	<u>Elev.</u> <u>Feet</u>
0	8.80	0	10.10	0	10.90
20	5.90	20	9.60	20	10.10
40	4.80	40	9.10	40	9.20
60	3.70	60	7.60	60	8.90
80	2.80	80	6.80	80	8.70
100	2.10	100	6.10	100	8.40
120	1.40	120	5.40	120	7.70
140	0.80	140	4.70	140	7.10
160	0.30	160	4.10	160	6.10
180	-0.20	180	3.60	180	4.80
200	-0.60	200	2.90	200	3.90
220	-0.90	220	2.40	220	3.10
240	-1.30	240	1.90	240	2.20
260	-1.70	260	1.40	260	1.60
280	-2.10	280	0.90	280	0.90
300	-2.20	300	0.40	300	0.40
320	-2.40	320	0.10	320	-0.10
340	-2.60	340	-0.40	340	-0.60
360	-2.70	360	-0.80	360	-1.10
380	-3.10	380	-1.20	380	-1.40
400	-3.10	400	-1.60	400	-1.70
420	-3.40	420	-1.80	420	-1.90
440	-3.70	440	-2.10	440	-2.20
460	-3.90	460	-2.60	460	-2.40
480	-4.60	480	-2.70	480	-2.60
500	-5.60	500	-3.10	500	-2.70
974	-14.50	520	-3.30	520	-2.90
1114	-17.30	540	-3.60	540	-3.30
1251	-20.40	560	-3.80	560	-3.60
1395	-23.90	580	-4.10	580	-4.10
1542	-26.80	600	-4.30	600	-4.60
1676	-29.30	1118	-21.80	620	-5.10
1812	-32.00	1208	-23.80	640	-6.10
1928	-34.10	1316	-25.80	660	-6.60
2083	-36.90	1460	-29.00	1077	-18.70
2212	-39.10	1580	-31.40	1263	-22.40
2367	-41.90	1728	-34.20	1456	-26.10
2485	-43.90	1834	-36.20	1592	-28.40
		1950	-38.20	1752	-31.10
		2075	-40.40	1939	-34.40
		2180	-42.30	2115	-37.50
				2281	-40.40
				2447	-43.40
				2597	-46.00

21 February 1974

(Cont'd)

SOUTH RANGE

Dist.      Elev.  
Feet      Feet

Ref. Rods:

1011      -14.80  
1375      -23.70  
1866      -33.00

INDIAN CANYON RANGE

Dist.      Elev.  
Feet      Feet

Ref. Rods

816            -12.80  
1219           -24.00  
1667           -32.90  
2343           -45.00  
3635           -65.00

NORTH RANGE

Dist.      Elev.  
Feet      Feet

Ref. Rods:

2756           -48.80  
2928           -51.70  
3110           -55.00  
3249           -57.30  
942            -13.80  
1331           -23.70  
1862           -32.90

11 March 1974

<u>SOUTH RANGE</u>		<u>INDIAN CANYON RANGE</u>		<u>NORTH RANGE</u>	
<u>Dist.</u> <u>Feet</u>	<u>Elev.</u> <u>Feet</u>	<u>Dist.</u> <u>Feet</u>	<u>Elev.</u> <u>Feet</u>	<u>Dist.</u> <u>Feet</u>	<u>Elev.</u> <u>Feet</u>
0	8.80	0	10.10	0	10.90
20	5.20	20	9.60	20	10.20
40	4.20	40	9.10	40	9.30
60	3.10	60	7.60	60	8.90
80	2.30	80	6.20	80	8.80
100	1.70	100	5.60	100	8.60
120	1.10	120	5.20	120	7.80
140	0.70	140	4.60	140	7.30
160	0.30	160	4.20	160	5.80
180	-0.10	180	3.60	180	4.70
200	-0.40	200	2.90	200	3.80
220	-0.70	220	2.40	220	3.10
240	-0.90	240	1.80	240	2.20
260	-1.30	260	1.40	260	1.60
280	-1.70	280	1.10	280	0.80
300	-2.20	300	0.60	300	0.30
320	-2.40	320	0.20	320	-0.10
340	-2.80	340	-0.10	340	-0.60
360	-3.30	360	-0.60	360	-0.90
		380	-0.90	380	-1.20
		400	-1.20	400	-1.60
		420	-1.60	420	-2.10
		440	-1.80	440	-1.80
		460	-2.10	460	-2.10
		480	-2.30		
		500	-2.60		

21 March 1974

<u>SOUTH RANGE</u>		<u>INDIAN CANYON RANGE</u>		<u>NORTH RANGE</u>	
<u>Dist.</u> <u>Feet</u>	<u>Elev.</u> <u>Feet</u>	<u>Dist.</u> <u>Feet</u>	<u>Elev.</u> <u>Feet</u>	<u>Dist.</u> <u>Feet</u>	<u>Elev.</u> <u>Feet</u>
0	8.80	0	10.10	0	10.90
20	5.40	20	9.60	20	10.10
40	4.60	40	9.10	40	9.30
60	4.10	60	7.80	60	8.90
80	3.30	80	6.30	80	8.80
100	2.40	100	5.80	100	8.60
120	1.60	120	5.30	120	7.80
140	0.90	140	4.90	140	7.10
160	0.60	160	4.40	160	5.80
180	0.10	180	4.20	180	4.60
200	-0.20	200	4.10	200	3.90
220	-0.80	220	3.40	220	3.20
240	-1.30	240	2.30	240	2.70
260	-1.60	260	1.60	260	2.10
280	-1.70	280	1.10	280	1.30
300	-2.60	300	0.70	300	0.70
320	-2.70	320	0.30	320	0.20
340	-3.10	340	0.10	340	-0.10
360	-3.70	360	-0.20	360	-0.40
380	-4.30	380	-0.60	380	-0.60
588	-7.30	400	-0.90	400	-0.60
726	-9.30	420	-1.10	420	-0.60
902	-12.30	440	-1.40	440	-0.80
1089	-16.70	460	-1.70	460	-1.10
1343	-23.10	480	-1.90	480	-1.60
1419	-24.30	500	-2.10	500	-2.10
1580	-27.40	520	-2.10	520	-2.40
1736	-30.40	540	-2.30	540	-2.80
1891	-33.40	560	-2.60	560	-3.30
2051	-36.30	580	-3.60	580	-3.90
2208	-39.10	823	-11.20	600	-4.40
2347	-41.30	1039	-20.00	718	-8.10
2517	-44.40	1238	-24.20	819	-10.10
2650	-46.80	1411	-27.90	981	-15.70
2829	-50.00	1591	-31.60	1159	-20.30
2962	-52.30	1779	-35.10	1314	-23.20
3126	-55.10	1969	-38.60	1452	-26.10
		2149	-41.80	1647	-29.40
		2336	-45.00	1807	-32.10
		2516	-48.00	1962	-34.80
		2707	-50.80	2118	-37.60
		2892	-53.70	2285	-40.60
		3094	-56.80	2437	-43.20
				2611	-46.20

21 March 1974 (Cont'd)

<u>SOUTH RANGE</u>		<u>INDIAN CANYON RANGE</u>		<u>NORTH RANGE</u>	
<u>Dist.</u> <u>Feet</u>	<u>Elev.</u> <u>Feet</u>	<u>Dist.</u> <u>Feet</u>	<u>Elev.</u> <u>Feet</u>	<u>Dist.</u> <u>Feet</u>	<u>Elev.</u> <u>Feet</u>
				2703	-47.90
				2942	-52.00
				3114	-55.00
				3281	-57.90
Ref. Rods:		Ref. Rods:		Ref. Rods:	
1011	-14.80	816	-13.50	942	-13.40
1375	-23.70	1219	-23.80	1331	-23.60
1866	-32.90	1667	-32.80	1862	-32.90
		2343	-45.00		
		3635	-65.00		

4 April 1974

<u>SOUTH RANGE</u>		<u>INDIAN CANYON RANGE</u>		<u>NORTH RANGE</u>	
<u>Dist.</u> <u>Feet</u>	<u>Elev.</u> <u>Feet</u>	<u>Dist.</u> <u>Feet</u>	<u>Elev.</u> <u>Feet</u>	<u>Dist.</u> <u>Feet</u>	<u>Elev.</u> <u>Feet</u>
0	8.80	0	10.10	0	10.90
20	6.60	20	9.60	20	10.10
40	5.20	40	9.10	40	9.30
60	4.10	60	7.80	60	8.90
80	3.10	80	6.80	80	8.70
100	2.20	100	6.30	100	8.60
120	1.60	120	5.60	120	7.60
140	1.10	140	5.10	140	7.20
160	0.40	160	4.40	160	6.10
180	-0.10	180	3.70	180	5.20
200	-0.60	200	3.10	200	4.20
220	-0.90	220	2.60	220	3.10
240	-1.30	240	2.10	240	2.30
260	-1.70	260	1.40	260	1.60
280	-2.10	280	0.90	280	0.90
300	-2.20	300	0.40	300	0.30
320	-2.60	320	0.10	320	-0.10
340	-2.70	340	-0.40	340	-0.60
360	-2.80	360	-0.70	360	-1.10
380	-3.10	380	-1.10	380	-1.40
400	-3.20	400	-1.60	400	-1.70
801	-11.90	420	-1.80	420	-1.90
911	-15.00	440	-2.20	440	-2.20
1062	-15.80	460	-2.60	460	-2.60
1202	-19.20	480	-2.60	480	-2.80
1343	-22.70	500	-3.20	500	-3.10
1471	-25.10	520	-3.90	520	-2.90
1637	-28.30	540	-4.20	540	-3.10
1763	-31.00	916	-13.90	560	-3.30
1907	-33.80	1091	-21.10	580	-3.60
2039	-36.20	1256	-24.60	600	-4.10
2182	-38.60	1420	-28.00	620	-4.40
2335	-41.30	1602	-32.00	640	-5.10
2483	-43.90	1794	-35.30	809	-9.80
2598	-46.00	1927	-37.80	963	-10.80
2720	-48.00	2081	-40.50	1121	-19.00
2866	-50.40	2246	-43.40	1292	-22.80
2994	-52.80	2421	-46.40	1459	-26.20
3137	-55.20	2583	-49.00	1625	-29.00
3294	-58.10	2723	-51.20	1789	-31.80
		2900	-53.80	1949	-34.50
		3091	-56.60	2121	-37.60
		3309	-60.10	2297	-40.70

4 April 1974 (Cont'd)

SOUTH RANGE

Dist.      Elev.  
Feet      Feet

Ref. Rods:

1011      -14.60  
1375      -23.70  
1866      -32.90

INDIAN CANYON RANGE

Dist.      Elev.  
Feet      Feet

Ref. Rods:

816      -13.20  
1219      -23.80  
1667      -32.80  
2343      -45.00  
3635      -65.00

NORTH RANGE

Dist.      Elev.  
Feet      Feet

2465      -43.70  
2612      -46.20  
2776      -49.10  
2964      -52.40  
3097      -54.80  
3238      -57.20  
3428      -60.50

Ref. Rods:

942      -13.10  
1331      -23.60  
1862      -32.90



30 April 1974

<u>SOUTH RANGE</u>		<u>INDIAN CANYON RANGE</u>		<u>NORTH RANGE</u>	
<u>Dist.</u> <u>Feet</u>	<u>Elev.</u> <u>Feet</u>	<u>Dist.</u> <u>Feet</u>	<u>Elev.</u> <u>Feet</u>	<u>Dist.</u> <u>Feet</u>	<u>Elev.</u> <u>Feet</u>
0	8.80	0	10.10	0	10.90
20	6.90	20	9.60	20	10.10
40	5.60	40	9.20	40	9.20
60	4.70	60	7.80	60	8.90
80	4.20	80	6.90	80	8.90
100	3.40	100	6.40	100	8.60
120	2.30	120	5.90	120	8.20
140	1.20	140	5.80	140	7.60
160	0.30	160	5.20	160	6.60
180	-0.40	180	4.60	180	5.80
200	-1.20	200	4.10	200	5.20
220	-2.10	220	3.30	220	4.40
240	-1.60	240	2.60	240	3.60
260	-1.30	260	2.10	260	2.90
280	-1.20	280	1.40	280	2.30
300	-1.30	300	1.10	300	1.60
320	-1.40	320	0.60	320	0.60
340	-1.60	340	0.30	340	0.10
360	-1.70	360	0.10	360	-0.30
380	-1.80	380	-0.20	380	-0.70
400	-1.90	400	-0.40	400	-1.10
420	-2.10	420	-0.60	420	-1.20
440	-2.40	440	-0.80	440	-1.60
460	-2.60	460	-1.20	460	-1.90
480	-2.90	480	-1.60	480	-2.20
1154	-18.10	500	-1.70	500	-2.70
1317	-22.00	520	-1.70	520	-3.10
1515	-25.90	540	-1.70	540	-3.20
1700	-29.50	560	-1.80	560	-3.60
1867	-32.90	580	-2.10	580	-4.10
2070	-36.70	600	-2.60	600	-4.60
2250	-39.90	874	-12.10	1135	-19.50
2450	-43.20	1038	-20.00	1300	-23.30
2628	-46.30	1196	-23.30	1423	-25.50
2846	-50.20	1359	-26.80	1590	-28.30
3013	-53.10	1523	-30.10	1738	-30.90
3206	-56.40	1702	-33.80	1894	-33.50
		1870	-36.80	2039	-36.10
		2044	-39.90	2173	-38.50
		2218	-43.10	2348	-41.60
		2384	-45.80	2527	-44.80
		2558	-48.60	2701	-47.80
		2739	-51.30	2875	-50.80

30 April 1974 (Cont'd)

<u>SOUTH RANGE</u>		<u>INDIAN CANYON RANGE</u>		<u>NORTH RANGE</u>	
<u>Dist.</u> <u>Feet</u>	<u>Elev.</u> <u>Feet</u>	<u>Dist.</u> <u>Feet</u>	<u>Elev.</u> <u>Feet</u>	<u>Dist.</u> <u>Feet</u>	<u>Elev.</u> <u>Feet</u>
		2914	-54.00	3032	-53.40
		3078	-56.50	3208	-56.70
		3258	-59.20	3425	-60.40
		3400	-61.40		
Ref. Rods:		Ref. Rods:		Ref. Rods:	
1011	-14.40	816	-13.50	942	-14.80
1375	-23.80	1219	-23.80	1331	-23.60
1866	-32.90	1667	-32.90	1862	-32.90
		2343	-45.00		
		3635	-65.00		

## APPENDIX C

### DESIGN AND DEVELOPMENT OF THE RECORDING DEPTH GAGE

#### INTRODUCTION

It was proposed that an accurate instrument for measuring the depth at various points along a beach profile be designed and developed as part of contract number DACW72-72-C-0020. The instrument would be designed to satisfy the need for accurate measurements just seaward of the break point of waves where fathometers and lead line sounding are inaccurate.

This instrument was conceived as an application of the very accurate absolute pressure sensors presently available to detect small changes in water level. The concept of design involved placing such a pressure sensor on the bottom and sensing the change in water level over a pre-determined period of time. The high frequency oscillations of the water surface due to waves would be electronically filtered out of the pressure sensor output to produce a single average reading for the depth.

#### PRELIMINARY DESIGN MAY-NOVEMBER 1972

The instrument is designed around a Statham Model PA506-53, 13 to 53 psia (absolute) pressure sensor which can accurately detect changes in water level of  $\pm 0.08$  feet (2.4 cm) in water depths as great as -58 feet (-17.7 m). Preliminary design of the instrument involved putting the output of this sensor through an amplifier low-pass filter and a variable gain amplifier onto a digital display. This electronic circuitry was intended to make an accurate measurement of the depth by filtering out the high frequency oscillations caused by waves. Filtering was achieved by using a capacitor which had a time constant of 3 minutes. The output from the filter was then amplified and read on the digital panel meter.

A prototype of this instrument was constructed in September 1972, and tested by progressively lowering the pressure sensor into a laboratory deep tank. This test indicated that the instrument gave unstable readings and tended to drift from zero reset. The initial change in design was to replace the integrated circuit used for amplification with a more stable unit. This resulted in the circuit design shown in Figure B-1. Also, the prototype instrument had a two and one-half digital panel meter for recording the data which was found to be of insufficient accuracy.

#### CONSTRUCTION, DECEMBER 1972 - MAY 1973

The completion of the electronic circuit design and initial testing resulted in an instrument that was believed to be ready for field use.

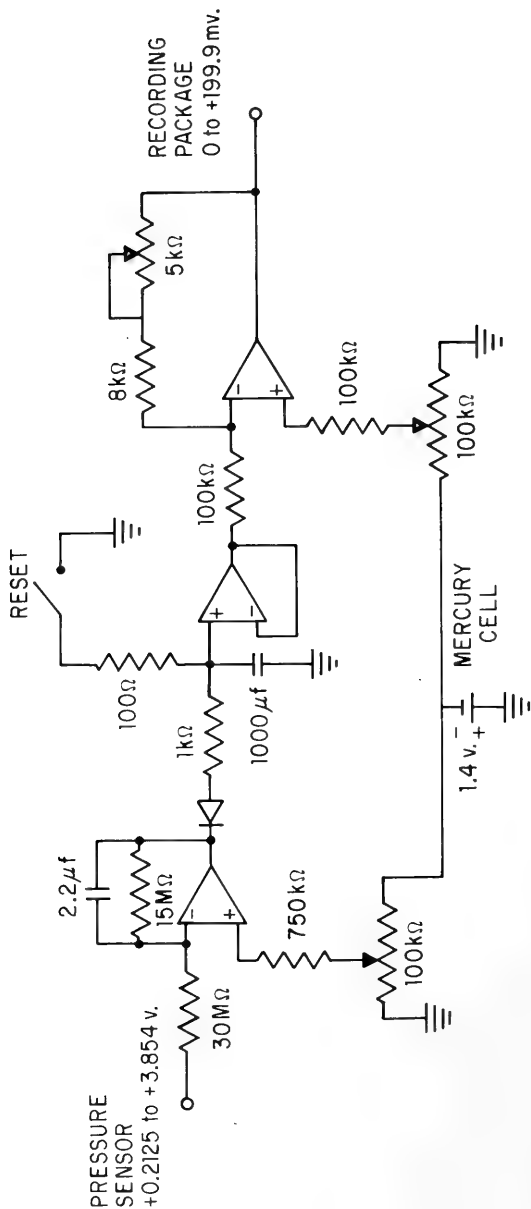

Figure B-1. Schematic diagram of signal conditioning circuitry for first version of the recording depth gage.

These components were then packaged for field use by building waterproof containers for the pressure sensor and the logic circuitry. These containers were constructed out of PVC pipe and fitted with caps that had "O" ring seals to prevent leaking at shallow depths. The pressure sensor housing was equipped with a pliable diaphragm to make it sensitive to the environment. Connections between the components of the instrument were made by waterproof oceanic connectors.

The pressure sensor, signal conditioning circuitry, and power supply batteries were then mounted on a metal platform for field use. This platform is a triangular piece of 1/2-inch-thick steel equipped with a vertical shank for shackling to the recovery line. Figure B-2 shows this assembly with the pressure sensor housing mounted vertically with the sensor diaphragm down so it is adjacent to the bottom and the signal conditioning circuitry in the horizontally mounted container. Power supply batteries were also mounted on the platform and waterproofed with a "paint-on" sealant.

Testing of this version of the instrument in the ocean from the end of Scripps Pier indicated a number of problems which caused erroneous measurements. The most serious problem was the progressive drift due to electronic instability. Other problems included leakage of the paint-on sealant and excessive drain on the batteries used as a power supply to the signal conditioning circuitry. At this point it became necessary to redesign the instrument and to restructure its components in order to improve its performance.

#### REDESIGN AND CONSTRUCTION OF THE INSTRUMENT

JUNE 1973 - FEBRUARY 1974

The failure of the recording depth gage to hold an accurate measurement and to drift from a zero setting was found to be related to the batteries used to power the signal conditioning circuitry. This could only be overcome by redesigning the circuit and replacing the batteries with a regulated power supply. Figure B-3 shows a schematic diagram for the present signal conditioning circuit which uses a 1.4-volt mercury cell as a constant reference voltage for the power supply. Also, a reset switch was installed in the circuit to facilitate making multiple measurements.

These changes required modification of the waterproof containers and the physical configuration of the instrument. The second version of the instrument required an enlarged signal conditioning package so that it could accommodate larger batteries for the power supply. This is now a PVC container 7 inches in diameter and 11 inches long. Figure B-4 shows the present physical configuration of the recording depth gage with a large and a small diameter waterproof package mounted vertically on the same steel frame that constitutes the sensing package. This instrument was then successfully tested in the laboratory deep tank and from Scripps Pier.

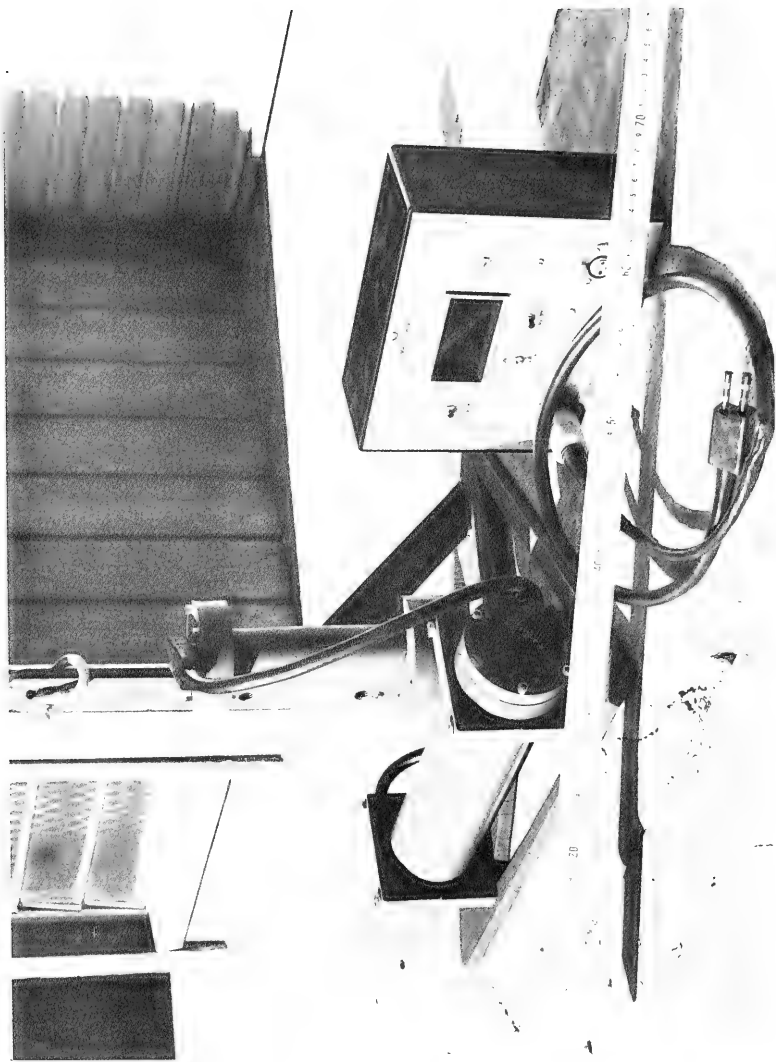
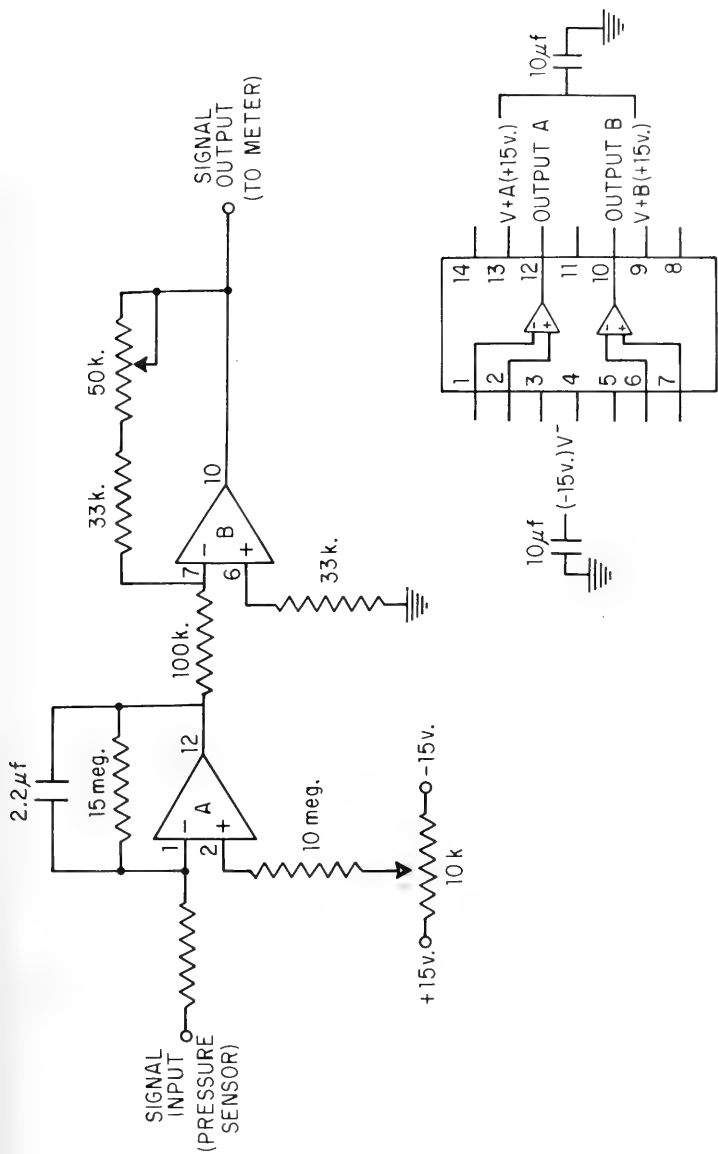

Figure B-2. First version of the recording depth gage showing the sensing package to the left which consists of a vertically mounted pressure sensor and a horizontally mounted logic circuitry container, and the recording package with a three digit panel meter readout.



FAIRCHILD UA747 DUAL FREQUENCY COMPENSATED OPERATIONAL AMPLIFIER

Figure B-3. Schematic diagram of signal conditioning circuitry for present version of recording depth gage.



Figure B-4. Recording depth gage showing the sensing package, recording package and batteries for the recording package. The two cylindrical containers of the sensing package, which house the logic circuitry and pressure sensor, are mounted on a metal frame that is designed to maintain their proper attitude on the sea floor.



## FIELD PREPARATION AND TESTING OF THE INSTRUMENT

March 1974 - May 1974

After testing of the instrument at Scripps Pier it was modified for field use and tested in the ocean under differing wave conditions. Most of the modifications necessary to make the instrument ready for field use involved enclosing the three and one-half digit panel meter (Analog Devices Model AD2001) in a splash-proof box and to arrange a small 12-volt wet cell and 5-volt power supply for it. This part of the instrument became the recording package of the instrument.

Use of the instrument involves dropping the sensing package on a station with a marker float attached to its recovery line. After a 3-minute sampling period the sensing package is recovered and the recording package plugged into it to read the retained measurement. Once the measurement has been read, the reset switch is activated to prepare the sensing package for another measurement.

In April and May 1974 the instrument was field tested in the ocean off Scripps Institution and at Indian Canyon Range. The results of these tests are shown in Figure B-5. At present the instrument is working properly and is available for field use.

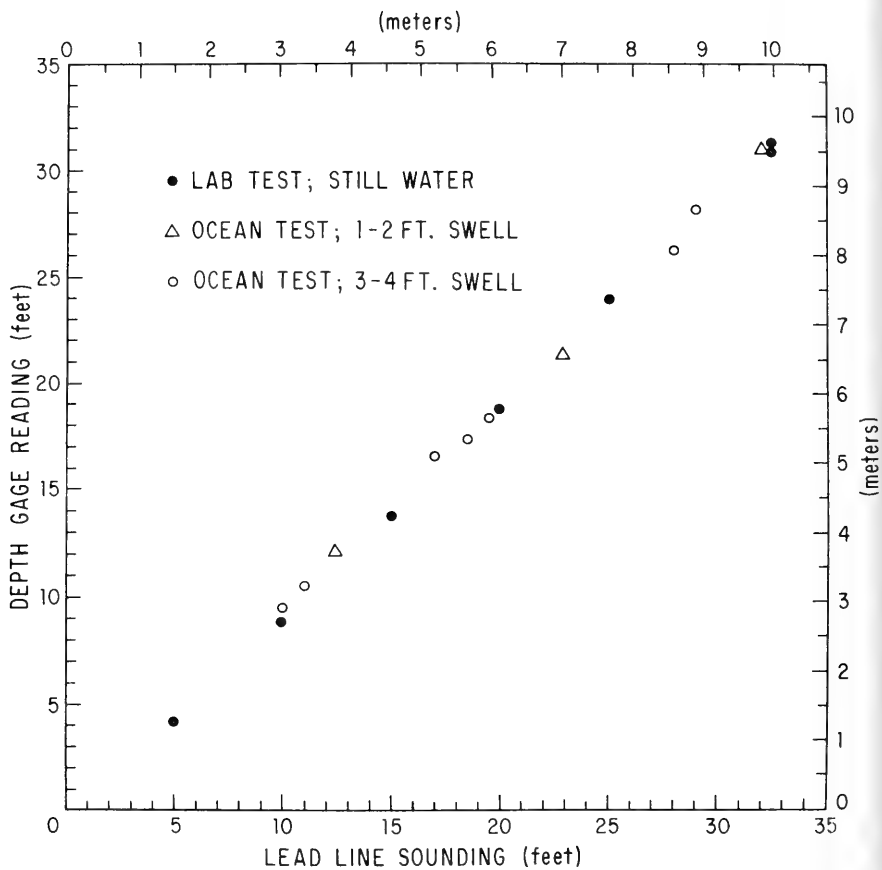

Figure B-5. Comparison of recording depth gage readings with lead line soundings for stillwater and field tests in the presence of waves.

APPENDIX D

VISUAL WAVE OBSERVATIONS FROM SOUTH RANGE  
TORREY PINES BEACH, CALIFORNIA  
JUNE 1972 - MAY 1974

Definition of Terms:

1. Period (average 10 waves) - CERC procedure where the observer notes the time period of 10 consecutive waves and divides by 10 for the average period.
2. Period (individual waves) - average period of several waves measured individually.
3. Breaker height - visual estimate of breaker height.
4. Breaker type - S = spilling  
P = plunging
5.  $\alpha_b$  - visual estimate of the angle of wave approach to the beach.

June 1972

Date	Period (Avg. 10 Waves) Sec.	Period (Indiv. Wave) Sec.	Breaker. Height Ft.	Breaker Type	$\alpha_b$ Degrees
1					
2	17.5	8	3	S	0°
3					
4					
5	12	8	2	S	0°
6	13.5	9	2	S	0°
7	19	9	3	S	5°S
8	18		1	S	0°
9	16.5	9	1	S	0°
10					
11					
12	13		4	S	0°
13	12.5		2	S	0°
14	12.5		2	S	0°
15	13.8		1	S	0°
16	12.5		3	S	0°
17					
18					
19	18	12	2	S	0°
20	18	14	2	S	0°
21	16	8	3	S	5°N
22	14.5	12	4	S	5°N
23	12	12	4	S	0°
24					
25					
26	15.5	15	3	S	0°
27	15	14	3	S	0°
28	14.5	8	3	S	5°N
29	13	7	3	S	0°
30	17	13	3	S	0°
31	17	13	3	S	0°

July 1972

Date	Period (Avg. 10 Waves Sec.	Period (Indiv. Wave) Sec.	Breaker Height Ft.	Breaker Type	$\alpha$ $\beta$ Degrees
1					
2					
3	14.5	15	4	S	5°S
4					
5	13	14	3	S	0°
6	13.5	14	3	S	5°N
7	11	9.2	3	S	0°
8					
9					
10	12	8	3	S	5°N
11	12	8	4	S	0°
12	12	8	4	S	0°
13	15	9.3	4	S	5°N
14					
15					
16					
17	14	12.8	3	S	0°
18	12	8.3	3	S	0°
19	13.5	9	3	S	5°S
20	13	8.8	3	S	5°S
21	CHOP	CHOP	2	S	0°
22					
23					
24	9	8	4	S	0°
25	10	7.3	4	S	0°
26	10	8	4	S	5°N
27	10	8	4	S	0°
28	12	8	4	S	0°
29					
30					
31	10	7.3	4	S	5°N

August 1972

Date	Period (Avg. 10 Waves) Sec.	Period (Indiv. Wave) Sec.	Breaker Height Ft.	Breaker Type	$\alpha_b$ Degrees
1					
2	10	8	4	S	5°S
3	12	7.5	3	S	0°
4	12	7	3	S	0°
5					
6					
7	9	7	3	S	10°N
8	11	6.5	2	S	5°N
9					
10	13	8.3	4	S	0°
11	16	10.7	5	S	0°
12					
13					
14	13				
15	9	7	4	S	5°N
16					
17	9	7	4	S	5°N
18	8	7	3	S	5°N
19					
20					
21	12	8	3	S	5°N
22	12	8	4	S	5°N
23	11	7	4	S	5°N
24	12	8	7	S	5°N
25	12	8.5	4	S	5°N
26					
27					
28	13	8.5	4	S	0°
29	16	12	3	S	0°
30	12	9	3	S	8°S
31	13	9	3	S	5°S

September 1972

Date	Period (Avg. 10 Waves) Sec.	Period (Indiv. Wave) Sec.	Breaker Height Ft.	Breaker Type	$\alpha_b$ Degrees
1	12	9	3	S	0°
2					
3					
4					
5	13	12	6	S	10°S
6	13	9	4	S	5°S
7	10	8	3	S	0°
8	10	9	2	S	0°
9					
10					
11	13	11	3	S	0°
12	12.3	10.3	2	S	0°
13	12	7	3	S	5°N
14	14	10.4	2	S	0°
15	13	10	1	S	0°
16					
17					
18	11	15	3	S	0°
19	17	15	2	S	3°S
20	15	8	3	S	0°
21	13	9.5	3	S	0°
22					
23					
24					
25	12	8	3	S	5°S
26					
27	16	15	2	S	5°S
28	12	8	4	S	0°
29	15	8	2	S	0°
30					
31					

October 1972

Date	Period (Avg. 10 Waves) Sec.	Period (Indiv. Wave) Sec.	Breaker Height Ft.	Breaker Type	$\alpha_b$ Degrees
1					
2	13	6	3	S	5°N
3	12	13	3	S	0°
4	10	8	3	S	0°
5	12	8	2	S	0°
6	14	8	3	S	0°
7					
8					
9	18	14	3	S	4°S
10	14	12	2	S	0°
11	18	14	2	S	5°S
12	14	9.5	3	S/P	0°
13	16	13.5	3	S	5°S
14					
15					
16	17	11	2	S	5°S
17	16	9	3	S	0°
18		10.5		P	0°
19	15	8.5	4	S/P	0°
20	10	5.5	4	S	5°N
21					
22					
23	10	8	2	S	5°N
24	18	8	2	S	5°N
25	12	8.5	2	S	5°N
26	14	8.5	2	S	5°N
27	15	8	2	S	5°N
28					
29					
30	9	6	3	S	10°N
31	10	8	2	S	5°N



November 1972

Date	Period (Avg.10 Waves) Sec.	Period (Indiv. Wave) Sec.	Breaker Height Ft.	Breaker Type	$\alpha_b$ Degrees
1	10	7	1	S	0°
2	12	7.5	2	S	0°
3	13	8.5	2	S	0°
4					
5					
6		9	6	P	0°
7		8	4	S	0°
8		6.5	6	S	0°
9		9.5	5	S	5°N
10		9	4	S	0°
11					
12					
13		8.5	4	S	5°N
14			5	P	
15		10	6	P	5°S
16			5	S	
17			7	S	
18					
19					
20	13	8	3	S	5°N
21	14	9	4	S	5°N
22	14	8.5	3	S	5°N
23		9	4	S	5°N
24					
25					
26					
27	12		4	S	0°
28	15	10	5	S	5°N
29	10	8.5	2	S	0°
30	9	7	2	S	5°N

## December 1972

Date	Period (Avg. 10 Waves) Sec.	Period (Indiv. Wave) Sec.	Breaker Height Ft.	Breaker Type	$\alpha_b$ Degrees
1	16	12	2	S	0°
2					
3					
4	9		2	S	0°
5	9	7	5	S	5°N
6	12	8	4	S	5°N
7	9	6	4	S	5°N
8	8	5.5	6	S	5°N
9					
10					
11	12	8	2	S	0°
12	13	9	2	S	0°
13	12	6.5	2	S	0°
14	12	7.5	2	S	0°
15	12	7.5	1	S	0°
16					
17					
18	12	12.8	3	S/P	0°
19	10.5	10.5	4	P	0°
20	10	10	4	P	0°
21	12	12	4	P	0°
22					
23					
24					
25					
26	12	11	9	S	5°N
27	13	14.5	9	P	5°N
28					
29					
30					
31					

January 1973

Date	Period (Avg. 10 Waves) Sec.	Period (Indiv. Wave) Sec.	Breaker Height Ft.	Breaker Type	$\alpha_b$ Degrees
1					
2	12	8	4	S	5°N
3	13	6.5	3	S	5°N
4			3	S	
5	12	7.5	3	S	5°N
6					
7					
8	10	11	2	S	0°
9	12			S	
10	15	14	9	S	5°N
11	14	11	3	S	0°
12	13	14	3	S	0°
13					
14					
15	14	13.5	3	S	0°
16	12	7.5	3	S	0°
17					
18	14	14	6	S	0°
19	9	6.5	6	S	0°
20					
21					
22	12	9	5	S	0°
23	12	8	3	S	0°
24	13	9	3	S	0°
25					
26	11	8	5	S	5°N
27					
28					
29	12	12	3	S	5°N
30	12	12	5	P	5°N
31	10	7.5	5	S	5°N

February 1973

Date	Period (Avg.10 Waves) Sec.	Period (Indiv. Wave) Sec.	Breaker Height Ft.	Breaker Type	$\alpha_b$ Degrees
1	10	10	2	S	0°
2					
3					
4					
5	10	7	5	P	5°S
6	12	12	4	S	5°S
7	13	10.5	4	S	5°S
8	14	8	4	S	5°S
9					
10					
11					
12	14	10	10	S	5°S
13	12	8	8	S	0°
14	12	14	7	S	0°
15					
16					
17					
18					
19					
20	16	15	6	P	0°
21	16	14.5	6	P	0°
22	13	13	4	S	0°
23	12	9	3	S	0°
24					
25					
26	10	7	4	S	0°
27	13	15	7	S	0°
28	18	16	10	S	0°

March 1973

Date	Period (Avg.10 Waves) Sec.	Period (Indiv. Wave) Sec.	Breaker Height Ft.	Breaker Type	$\alpha_b$ Degrees
1	11	12.5	5	S	5°S
2	10	7	4	S	5°N
3					
4					
5	11	7	5	S	5°N
6	13	7.5	3	S	0°
7	10	8	5	S	5°S
8					
9	12	7.5	6	S	0°
10					
11					
12	14	15	8	S	0°
13	9	6	5	S	0°
14	13	8	7	S	5°N
15	15	9.5	4	S	0°
16	12	8	4	S	0°
17					
18					
19					
20	9	6.5	5	S	0°
21	12	7.5	4	S	5°N
22	9	6	5	S	5°N
23	13	8	6	S	5°N
24					
25					
26					
27	10	7	6	S	5°N
28	9	6	7	S	5°N
29	12	13	7	S	5°N
30	16	14	6	S	5°N
31					

April 1973

Date	Period (Avg. 10 Waves) Sec.	Period (Indiv. Wave) Sec.	Breaker Height Ft.	Breaker Type	$\alpha_b$ Degrees
1					
2	12	8	6	S	5°N
3	14	15	5	S	5°N
4	14	12	5	S	0°
5					
6	10	7	5	S	5°N
7					
8					
9	14	14	3	S	5°N
10	13	13	3	S	5°N
11			4		
12	13	11	4	S	0°
13	12	8	5	S	0°
14					
15					
16	10	11	5	S	0°
17	11	12	5	S	5°N
18	10	6.5	10	S	5°N
19	13	9	9	S	5°N
20	14	12	7	S	5°N
21					
22					
23	8	7	4	S	5°N
24	10	8	5	S	5°N
25	13	11	4	S	0°
26	10	8	3	S	0°
27	12	13	2	S	0°
28					
29					
30	12	9	3	S	0°

May 1973

Date	Period (Avg. 10 Waves) Sec.	Period (Indiv. Wave) Sec.	Breaker Height Ft.	Breaker Type	$\alpha_b$ Degrees
1	12	9	3	S	0°
2	10	9	4	S	0°
3	10	8	3	S	0°
4	8	7	4	S	0°
5					
6					
7	14	9.5	3	S	0°
8	11	11	5	S	0°
9	12	11	4	S	0°
10	14	12	4	S	5°N
11	13	13	3	S	0°
12					
13					
14	13	13	3	S	0°
15	12	8	3	S	0°
16	13	10.5	3	S	0°
17	10.5	11	3	S	5°N
18	12	8.5	4	S	0°
19					
20					
21	11.5	9	3	S	5°N
22	13.5	10	5	S	5°N
23	10	9	4	S	5°N
24	10	8.5	3	S	5°N
25	13	12	5	S	5°N
26					
27					
28					
29	18	8.6	3	S	0°
30	14	9.3	3	S	0°
31	10	8	4	S	5°N

June 1973

Date	Period (Avg.10 Waves) Sec.	Period (Indiv. Wave) Sec.	Breaker Height Ft.	Breaker Type	$\alpha_b$ Degrees
1	13	12	3	S	0°
2					
3					
4	11.5	8	2	S	5°N
5	13	9.5	2	S	5°N
6	9	8	2	S	5°N
7	9	7.5	2	S	0°
8	10	8	2	S	5°N
9					
10					
11					
12	10	7.5	3	S	5°N
13	14	12.5	4	S	5°N
14	12	10	7	S	5°N
15	13	9.2	7	S	5°N
16					
17					
18	12	9.3	6	S	5°N
19	10	9	4	S	
20	10	8	2	S	0°
21	10	8	2	S	0°
22	14	13	4	S	5°S
23					
24					
25	14	12	5	S	0°
26	12	9.6	4	S	0°
27	12.5	11	3	S	5°S
28	10	10	2	S	5°S
29	10	8	2	S	0°
30					



July 1973

Date	Period (Avg. 10 Waves) Sec.	Period (Indiv. Wave) Sec.	Breaker Height Ft.	Breaker Type	$\alpha_b$ Degrees
1					
2	12	10	6	S	5°S
3	10	9	6	S	5°N
4					
5	13	11	3	S	0°
6	10	8	3	S	5°N
7					
8					
9	10	7.7	2	S	5°N
10	12	9	2	S	0°
11	12	8	3	S	0°
12	10	7	6	S	5°N
13	12	8	5	S	0°
14					
15					
16	9	6.7	2	S	5°N
17	8	6.5	3	S	5°N
18	10	7	3	S	0°
19	10	7	3	S	5°N
20	10	7	3	S	5°N
21					
22					
23	12	11	4	S	5°N
24	13	10.5	5	S	5°N
25	12	8	6	S	5°N
26	13	15	6	S	5°S
27	15	14	4	S	5°S
28					
29					
30	15	14	4	S	5°S
31	14	14	4	S	5°S

August 1973

Date	Period (Avg. 10 Waves) Sec.	Period (Indiv. Wave) Sec.	Breaker Height Ft.	Breaker Type	$\alpha_b$ Degrees
1	13	8	2	S	5°S
2	11.5	8.3	2	S	0°
3	13	9	3	S	0°
4					
5					
6	13	9.3	2	S	0°
7	13	9.3	3	S	0°
8	12.5	8	3	S	0°
9	9	8.5	4	S	5°N
10	9.5	8	5	S	5°N
11					
12					
13	10	8	3	S	5°N
14	9	6.5	2	S	0°
15	12	11.5	2	S	5°S
16	15	15	4	S	5°S
17	15	15	5	S	5°S
18					
19					
20	8	8	3	S	5°N
21	10	8	2	S	5°N
22	10	7.5	4	S	5°N
23	9.5	8	5	S	0°
24		10	4		0°
25					
26					
27	15	15	2	S	5°S
28	11	11	2	S	0°
29	14	15	2	S	5°S
30	14	11	2	S	0°
31	12	11	2	S	0°

September 1973

Date	Period (Avg. 10 Waves) Sec.	Period (Indiv. Wave) Sec.	Breaker Height Ft.	Breaker Type	$\alpha_b$ Degrees
1					
2					
3					
4	14	9.5	2	S	5°S
5	13	8.5	2	S	5°S
6	7.5	7	3	S	5°N
7	8.5	9.6	4	S	5°N
8					
9					
10	8.7	9.6	2	S	0°
11	8.2	8	1	S	0°
12	7.1	8.9	2	S	0°
13	11	10.7	2	S	5°S
14	13	11.4	2	S	0°
15					
16					
17	15	14	2	S	5°N
18	12	10	3	S	0°
19	10	8.6	3	S	0°
20	11	8.5	4	S	5°N
21	8	8	5	S	5°N
22	8	8	5	S	5°N
23					
24	9	8	5	S	0°
25	7.7	8	4	S	0°
26	13	11	4	S	0°
27	11	13	5	S	5°S
28	14	15	5	S	8°S
29					
30					

October 1973

Date	Period (Avg.10 Waves) Sec.	Period (Indiv. Wave) Sec.	Breaker Height Ft.	Breaker Type	$\alpha_b$ Degrees
1	12	12	2	S	5°S
2	10	8.5	2	S	5°S
3	7.5	7.5	4	S	5°N
4	12	8.5	3	S	5°N
5	13	8.5	2	S	5°N
6					
7					
8	10	8	2	S	5°N
9	6.5	6	4	S	5°N
10	8	6.5	4	S	5°N
11	11	8.5	3	S	0°
12	12	8	2	S	0°
13					
14					
15	12.5	11.5	2	S	0°
16	10	8	3	S	0°
17	11	11	4	S	5°S
18	14	12	4	S	0°
19	12	11.5	4	S	5°S
20					
21					
22	14	14	4	S/P	5°S
23	13	12	3	S/P	5°S
24	12	13	5	S	5°N
25	10	8	5	S	5°N
26	10	7.4	4	S	5°N
27					
28					
29	12	11.5	4	S	5°N
30	14	14	8	P	5°N
31	14	12	6	S/P	5°N

November 1973

Date	Period (Avg.10 Waves) Sec.	Period (Indiv. Wave) Sec.	Breaker Height Ft.	Breaker Type	$\alpha_b$ Degrees
1	10	11	4	S	5°N
2	10.5	7.5	3	S	5°N
3					
4					
5	14	14	3	S	0°
6	11	10.5	2	S	5°N
7	11	10.3	4	S	5°N
8	9.5	9	3	S	0°
9	10	9	2	S	0°
10					
11					
12	10	10	4	S	5°N
13	10	11.3	6	S	5°N
14	9	9	4	S	0°
15	11	8.2	4	S	0°
16	10	8	3	S	0°
17					
18					
19	9.8	9.7	5	S	0°
20	8.5	8.7	4	S	0°
21	8.5	9	4	S	5°N
22					
23					
24					
25					
26	10	8.5	5	S	0°
27	14	13.3	5	S	0°
28	14	12.5	3	S	5°S
29	12	9.8	4	S	5°S
30	12	14	6	S/P	0°

December 1973

Date	Period (Avg.10 Wave) Sec.	Period (Indiv. Wave) Sec.	Breaker Height Ft.	Breaker Type	$\alpha_b$ Degrees
1					
2					
3	8	8.5	4	S	0°
4	10	8	4	S	5°N
5	12	11	2	S	0°
6	15	14	4	S	0°
7	12.3	12.7	3	S/P	0°
8					
9					
10	14	12	3	S	5°S
11	15	15	6	S	5°S
12	13	10.7	6	S	5°S
13	12	11.4	5	S	5°S
14	16	16	7	S	5°S
15					
16					
17	10	8	4	S	
18	12	12	4	S	5°S
19	11	11.6	4	S/P	5°S
20	14	14.3	5	P	5°S
21	15	11.8	6	S	5°S
22					
23					
24					
25					
26	12	11.5	5	S	0°
27	11	8.8	4	S	0°
28					
29					
30					
31					

January 1974

Date	Period (Avg. 10 Waves) Sec.	Period (Indiv. Wave) Sec.	Breaker Height Ft.	Breaker Type	$\alpha_b$ Degrees
1					
2	11.5	8	5	S	5°N
3	13	11.8	4	S	5°S
4	5.5	5	2	S	15°S
5					
6					
7	10	6	2	S	10°S
8	9	9.2	6	S	8°S
9		8	4	S	5°S
10	16	15.5	6	S	5°S
11	16	16	6	S	5°S
12					
13					
14	13.5	13	6	S/P	5°S
15	13	12.7	5	S/P	5°S
16	12.5	11.5	6	S/P	5°S
17	15	14.5	6	S/P	5°S
18				S	
19					
20					
21	11	11	6	S	5°N
22	13	12.5	5	S	0°
23	10	11	3	S	5°N
24			3	S	
25			3	S	
26					
27					
28	10	10	3	S	0°
29	12	9.7	4	S	5°N
30	14	14.5	4	S	5°N
31	10	9.5	2	S	0°

February 1974

Date	Period (Avg.10 Waves) Sec.	Period (Indiv. Wave) Sec.	Breaker Height Ft.	Breaker Type	$\alpha_b$ Degrees
1	7	7.3	2	S	0°
2					
3					
4	15	15	5	S	0°
5	10	10	5	S	
6	12	12	7	S	5°N
7	11	12	4	S	0°
8	15	14.5	3	S	0°
9					
10					
11	13.5	13.2	5	S/P	5°N
12	15	15	6	S	5°N
13	10	8.5	4	S	5°N
14	12	11	4	S	0°
15					
16					
17					
18					
19	14	14.5	5	S	5°N
20	9	8.7	7	S	5°N
21					
22	12	12	6	S/P	5°N
23					
24					
25	10	10	3	S	0°
26	14	11	2	S	0°
27	10	8.5	3	S	0°
28	13	13	3	S	5°N



March 1974

Date	Period (Avg.10 Waves) Sec.	Period (Indiv. Wave) Sec.	Breaker Height Ft.	Breaker Type	$\alpha_b$ Degrees
1	12	12.5	4	S	0°
2					
3					
4	11	11	8	S	0°
5	10	8	4	S	5°N
6	11	9.5	3	S	0°
7	12	8	2	S	0°
8	6	6.2	9	S	0°
9					
10					
11	12.5	8	2	S	0°
12	12	8	2	S	0°
13	16	14.5	4	S	5°N
14		9	3	S	
15		9	3	S	
16					
17					
18	12	12	3	S	5°S
19	14.5	12	2	S	0°
20	14	13.9	2	S	5°S
21		12	2	S	5°S
22	12.5	12.5	2	S	5°S
23					
24					
25					
26	13	12.3	4	S	5°S
27	15	15.5	7	S	0°
28	15	15	7	S	0°
29	14.5	14	6	S	0°
30					
31					

April 1974

Date	Period (Avg. 10 Waves) Sec.	Period (Indiv. Wave) Sec.	Breaker Height Ft.	Breaker Type	$\alpha_b$ Degrees
1	13.5	12.1	6	S	0°
2	10	7.3	6	S	0°
3	11	7	6	S	0°
4	11.5	11.5	5	S	0°
5	14	10.7	3	S	0°
6					
7					
8	10	10	3	S	0°
9	6.3	6.1	3	S	5°N
10	10	7.6	7	S	5°N
11	15	9	7	S	5°N
12					
13					
14					
15	12.5	11.1	2	S	5°N
16	11	8.4	4	S	5°N
17	12	12	4	S	0°
18	10	14.1	4	S	0°
19	10	10.4	4	S	0°
20					
21					
22	10	14.5	2	S	5°N
23	15	15	2	S	5°N
24	16	14	2	S	0°
25	9	8	4	S	0°
26	10	8.5	4	S	5°N
27					
28					
29	10	8.5	4	S	5°N
30	10	8.5	3	S	5°N

May 1974

Date	Period (Avg. 10 Waves) Sec.	Period (Indiv. Wave) Sec.	Breaker Height Ft.	Breaker Type	$\alpha_b$ Degrees
1	8	8	3	S	5°N
2	10	9	4	S	5°N
3					
4					
5					
6	12	12	4	S	5°N
7	13.5	12	3	S	5°N
8	13.5	12	2	S	5°N
9					
10					
11					
12					
13		11.5	4	S	5°N
14		10.5	4	S	5°N
15					
16		11	4	S	5°N
17		8	6	S	5°N
18					
19					
20		8.5	4	S	5°N
21		8.5	3	S	5°N
22		8	4	S	5°N
23		8	4	S	5°N
24		8	4	S	5°N
25		9	4	S	5°N

APPENDIX E

COMPARISON OF PRESSURE SENSOR ARRAY AND VISUAL OBSERVATIONS  
OF WAVES AT TORREY PINES BEACH, CALIFORNIA

FEBRUARY 1973 - MAY 1974

Definition of terms:

1.  $H_b$  : (Pressure sensors) calculated breaker height from energy density of the energy spectral peak and refraction to the shoreline.
2.  $H_b$  : (Visual observation) visual estimate of breaker height by observer on the beach.
3. Period: (Pressure sensors) model period for the defined peak of the data from all four pressure sensors of the array.
4. Period: (Visual observations) the average period of 10 individual waves as seen by the observer.
5.  $\alpha_o$  : The direction of best fit to a single wave train of the data measured by the four-sensor array. Angle is measured from the normal to the array in 33-foot-water (10 meters) depth.
6.  $\Delta\alpha_o$  : Uncertainty assigned to  $\alpha_o$ .
7.  $\alpha_b$  : (Pressure sensors) the angle of approach of a wave to the beach calculated by refracting the measured direction of best fit to the array shoreward to the breaker depth of the wave relative to MSL.
8.  $\alpha_b$  : (Visual observations) the observed angle of approach of the waves relative to the beach at the break point.

Measurements from pressure sensors are data from Table V-1 of Inman (in preparation, 1975).

## Measurements From Pressure Sensors

## Visual Observations

SAS Run and Date	Period Sec	$\alpha_0$ Degrees	$\Delta\alpha_0$ Degrees	$\alpha_b$ Degrees	$H_b$ Feet	Indiv. Period Sec	$\alpha_b$ Degrees	$H_b$ Feet
SAS-1-13 Feb. 73-02	12.3 16.4	12°S	± 3°	0°	5.8 3.0	8	0°	8
SAS-1-14 Feb. 73-02	14.2 6.4	9°S 10°S	± 2° ± 2°	1°N 1°N	7.4 2.0	14	0°	7
SAS-1-20 Feb. 73-03	16.8 8.8 5.9 5.0	13°S 14°S	± 1° ± 2°	0° 0°	6.1 2.5 1.4 0.7	15	0°	6
SAS-1-21 Feb. 73-02	16.8 6.9 5.6	13°S 10°S	± 1° ± 3°	0° 0°	6.3 0.9 0.9	14.5	0°	6
SAS-1-22 Feb. 73-02	14.2 5.0	17°S 6°S	± 2°	1°S 1°N	4.5 0.6	13	0°	4
SAS-1-23 Feb. 73-02	12.3 6.9 4.5	3°N 33°N	± 2° ± 3°	1°N 3°S	3.1 0.8 0.5	9	0°	3
SAS-1-10 Apr. 73-03	12.3 9.8 6.4 4.3				2.8 1.7 0.7 0.4	13	5°N	3
SAS-1-12 Apr. 73-03	14.2 6.4				4.4 2.3	11	0°	4

Measurements From Pressure Sensors

Visual Observations

SAS Run and Date	Period Sec.	$\alpha$ Degrees	$\Delta\alpha$ Degrees	$\alpha_b$ Degrees	$H_b$ Feet	Indiv. Period Sec.	b Degrees	$H_b$ Feet
SAS-1-13 Apr. 73-03	14.2 5.9 4.1				4.3 2.7 1.5	8	0°	5
SAS-1-16 Apr. 73-03	16.8 6.9				3.0 2.8	11	0°	5
SAS-1-17 Apr. 73-03	12.3 9.8 6.4 5.3				3.0 1.9 2.1 1.8	12	5°N	5
SAS-1-16 May 73-03	14.2 9.8 4.3	22°S 0° 28°S	± 3° ± 2° ± 5°	1°S 2°N 0°	1.6 2.6 0.7	10.5	0°	3
SAS-1-17 May 73-02	10.9 4.5	2°S 8°N	± 2° ± 3°	5°N 1°N	3.3 0.8	11	5°N	3
SAS-1-18 May 73-03	12.3 4.5	10°S 2°S	± 2° ± 5°	0° 3°N	2.8 1.2	8.5	0°	4
SAS-1-21 May 73-03	14.2 5.6	20°S	± 5°	1°S	2.7 1.8	9	5°N	3
SAS-1-22 May 73-03	10.9 6.0	0°	± 2°	2°N	2.8 1.5	10	5°N	5
SAS-1-23 May 73-03	10.9 6.0	4°S 30°N	± 3° ± 5°	2°N 10°N	2.8 1.4	9	5°N	4

Measurements From Pressure Sensors

Visual Observations

SAS Run and Date	Period Sec.	$\alpha_o$ Degrees	$\Delta\alpha_o$ Degrees	$\alpha_b$ Degrees	$H_b$ Feet	Indiv. Period Sec.	$\alpha_b$ Degrees	$H_b$ Feet
SAS-1-24 May 73-03	14.2 6.9	36°S 4°N	± 5° ± 3°	2°S 3°N	1.7 2.0	8.5	5°N	3
SAS-1-25 May 73-03	12.3 6.4	5°S 6°S	± 2° ± 5°	1°N 1°N	3.5 1.7	12	5°N	5
SAS-1-29 May 73-03	14.2 8.8	23°S 0°	± 1° ± 3°	1°S 2°N	1.9 1.7	8.6	0°	3
SAS-1-30 May 73-03	14.2 7.4	21°S	± 2°	1°S	2.0 1.6	9.3	0°	3
SAS-1-31 May 73-03	16.8 10.9 7.4	24°S 2°S	± 1° ± 2°	1°S 2°N	3.0 2.2 1.3	8	5°N	4
SAS-1-01 June 73-02	16.8 12.3 6.4	23°S 1°S	± 1° ± 2°	1°S 2°N	2.9 2.6 1.2	12	0°	3
SAS-1-04 June 73-03	12.3 8.8 4.3	15°S 5°N	± 3° ± 2°	0° 3°N	3.1 1.7 0.7	8	5°N	2
SAS-1-05 June 73-03	12.3 8.8	6°S 1°N	± 3° ± 2°	1°N 2°N	1.8 2.2	9.5	5°N	2
SAS-1-09 July 73-03	16.8 8.1	25°S 3°N	± 1° ± 3°	1°S 3°N	1.6 2.5	7.7	5°N	2

Measurements From Pressure Sensors

Visual Observations

SAS Run and Date	Period Sec.	$\alpha_0$ Degrees	$\Delta\alpha_0$ Degrees	$\alpha_b$ Degrees	$H_b$ Feet	Indiv. Period Sec.	$\alpha_b$ Degrees	$H_b$ Feet
SAS-1-10 July 73-02	14.2	24°S	± 1°	1°S	1.7	9	0°	2
	8.8	3°N	± 3°	3°N	2.8			
	4.8				1.0			
SAS-1-11 July 73-02	14.2	26°S	± 1°	1°S	1.7	8	0°	3
	9.8	0°	± 3°	2°N	2.5			
	5.3				2.4			
SAS-1-16 July 73-03	14.2	22°S	± 1°	1°S	1.8	6.7	5°N	2
	9.8	1°N	± 4°	2°N	2.5			
	5.9				1.7			
SAS-1-19 July 73-03	16.8	22°S	± 3°	1°S	3.3	7	5°N	3
	5.9	7°N	± 4°	4°N	1.8			
SAS-1-20 July 73-03	16.8	1°N	± 1°	1°S	3.2	7	5°N	3
	6.9	21°N	± 2°	2°N	2.4			
SAS-1-23 July 73-03	14.2	23°S	± 1°	1°S	2.3	11	5°N	4
	9.8	3°N	± 3°	3°N	3.2			
	5.6				1.8			
SAS-1-24 July 73-02	16.8	29°S	± 1°	2°S	2.6	10.5	5°N	5
	8.1	3°N	± 4°	4°N	3.9			
SAS-1-30 July 73-02	14.2	26°S	± 1°	2°S	3.2	14	5°S	4
	8.8	2°N	± 3°	2°N	1.6			
	5.3				1.4			
SAS-1-01 Aug. 73-03	14.2	24°S	± 2°	1°S	2.1	8	5°S	2
	6.9	9°N	± 4°	4°N	1.8			



Measurements From Pressure Sensors

Visual Observations

SAS Run and Date	Period Sec.	$\alpha_o$ Degrees	$\Delta\alpha_o$ Degrees	$\alpha_b$ Degrees	$H_b$ Feet	Indiv. Period Sec.	$\alpha_b$ Degrees	$H_b$ Feet																																																																																																																										
SAS-1-02 Aug. 73-03	14.2	25°S	± 1°	5°S	2.2	8.3	0°	2																																																																																																																										
	8.1	6°N	± 3°	9°N	2.4				SAS-1-10 Aug. 73-03	14.2	25°S	± 1°	1°S	2.6	8	5°N	5	8.1	7°N	± 4°	4°N	2.1	SAS-1-15 Aug. 73-02	16.8	23°S	± 1°	1°S	3.4	11.5	5°S	2	5.6	4°N	± 4°	3°N	1.0	SAS-1-16 Aug. 73-03	16.8	23°S	± 3°	1°S	4.2	15	5°S	4	8.1	7°N	± 4°	3°N	1.5	SAS-1-20 Aug. 73-03	12.3	24°S	± 3°	1°S	2.3	8	5°N	3	5.6	6°N	± 4°	4°N	1.8	SAS-1-21 Aug. 73-03	16.8	26°S	± 1°	2°S	3.6	8	5°N	2	8.1				2.4	SAS-1-22 Aug. 73-03	16.8	27°S	± 2°	2°S	3.4	7.5	5°N	4	7.4				3.1		6.0				2.5				SAS-1-23 Aug. 73-03	14.2	25°S	± 1°	1°S	2.8	8	0°	5	8.1	2°S	± 2°	3°N	3.2	6.4	7°S	± 3°	1°N	2.5	SAS-1-24 Aug. 73-03	16.8	24°S	± 2°	1°S	2.1	10	0°	4	8.1
SAS-1-10 Aug. 73-03	14.2	25°S	± 1°	1°S	2.6	8	5°N	5																																																																																																																										
	8.1	7°N	± 4°	4°N	2.1				SAS-1-15 Aug. 73-02	16.8	23°S	± 1°	1°S	3.4	11.5	5°S	2	5.6	4°N	± 4°	3°N	1.0	SAS-1-16 Aug. 73-03	16.8	23°S	± 3°	1°S	4.2	15	5°S	4	8.1	7°N	± 4°	3°N	1.5	SAS-1-20 Aug. 73-03	12.3	24°S	± 3°	1°S	2.3	8	5°N	3	5.6	6°N	± 4°	4°N	1.8	SAS-1-21 Aug. 73-03	16.8	26°S	± 1°	2°S	3.6	8	5°N	2	8.1				2.4	SAS-1-22 Aug. 73-03	16.8	27°S	± 2°	2°S	3.4	7.5	5°N	4	7.4				3.1		6.0				2.5				SAS-1-23 Aug. 73-03	14.2	25°S	± 1°	1°S	2.8	8	0°	5	8.1	2°S	± 2°	3°N	3.2		6.4	7°S	± 3°	1°N	2.5				SAS-1-24 Aug. 73-03	16.8	24°S	± 2°	1°S	2.1	10	0°	4	8.1	4°S	± 2°	2°N	3.2						
SAS-1-15 Aug. 73-02	16.8	23°S	± 1°	1°S	3.4	11.5	5°S	2																																																																																																																										
	5.6	4°N	± 4°	3°N	1.0				SAS-1-16 Aug. 73-03	16.8	23°S	± 3°	1°S	4.2	15	5°S	4	8.1	7°N	± 4°	3°N	1.5	SAS-1-20 Aug. 73-03	12.3	24°S	± 3°	1°S	2.3	8	5°N	3	5.6	6°N	± 4°	4°N	1.8	SAS-1-21 Aug. 73-03	16.8	26°S	± 1°	2°S	3.6	8	5°N	2	8.1				2.4	SAS-1-22 Aug. 73-03	16.8	27°S	± 2°	2°S	3.4	7.5	5°N	4	7.4				3.1		6.0				2.5				SAS-1-23 Aug. 73-03	14.2	25°S	± 1°	1°S	2.8	8	0°	5	8.1	2°S	± 2°	3°N	3.2		6.4	7°S	± 3°	1°N	2.5				SAS-1-24 Aug. 73-03	16.8	24°S	± 2°	1°S	2.1	10	0°	4	8.1	4°S	± 2°	2°N	3.2																				
SAS-1-16 Aug. 73-03	16.8	23°S	± 3°	1°S	4.2	15	5°S	4																																																																																																																										
	8.1	7°N	± 4°	3°N	1.5				SAS-1-20 Aug. 73-03	12.3	24°S	± 3°	1°S	2.3	8	5°N	3	5.6	6°N	± 4°	4°N	1.8	SAS-1-21 Aug. 73-03	16.8	26°S	± 1°	2°S	3.6	8	5°N	2	8.1				2.4	SAS-1-22 Aug. 73-03	16.8	27°S	± 2°	2°S	3.4	7.5	5°N	4	7.4				3.1		6.0				2.5				SAS-1-23 Aug. 73-03	14.2	25°S	± 1°	1°S	2.8	8	0°	5	8.1	2°S	± 2°	3°N	3.2		6.4	7°S	± 3°	1°N	2.5				SAS-1-24 Aug. 73-03	16.8	24°S	± 2°	1°S	2.1	10	0°	4	8.1	4°S	± 2°	2°N	3.2																																		
SAS-1-20 Aug. 73-03	12.3	24°S	± 3°	1°S	2.3	8	5°N	3																																																																																																																										
	5.6	6°N	± 4°	4°N	1.8				SAS-1-21 Aug. 73-03	16.8	26°S	± 1°	2°S	3.6	8	5°N	2	8.1				2.4	SAS-1-22 Aug. 73-03	16.8	27°S	± 2°	2°S	3.4	7.5	5°N	4	7.4				3.1		6.0				2.5				SAS-1-23 Aug. 73-03	14.2	25°S	± 1°	1°S	2.8	8	0°	5	8.1	2°S	± 2°	3°N	3.2		6.4	7°S	± 3°	1°N	2.5				SAS-1-24 Aug. 73-03	16.8	24°S	± 2°	1°S	2.1	10	0°	4	8.1	4°S	± 2°	2°N	3.2																																																
SAS-1-21 Aug. 73-03	16.8	26°S	± 1°	2°S	3.6	8	5°N	2																																																																																																																										
	8.1				2.4				SAS-1-22 Aug. 73-03	16.8	27°S	± 2°	2°S	3.4	7.5	5°N	4	7.4				3.1		6.0				2.5				SAS-1-23 Aug. 73-03	14.2	25°S	± 1°	1°S	2.8	8	0°	5	8.1	2°S	± 2°	3°N	3.2		6.4	7°S	± 3°	1°N	2.5				SAS-1-24 Aug. 73-03	16.8	24°S	± 2°	1°S	2.1	10	0°	4	8.1	4°S	± 2°	2°N	3.2																																																														
SAS-1-22 Aug. 73-03	16.8	27°S	± 2°	2°S	3.4	7.5	5°N	4																																																																																																																										
	7.4				3.1																																																																																																																													
	6.0				2.5																																																																																																																													
SAS-1-23 Aug. 73-03	14.2	25°S	± 1°	1°S	2.8	8	0°	5																																																																																																																										
	8.1	2°S	± 2°	3°N	3.2																																																																																																																													
	6.4	7°S	± 3°	1°N	2.5																																																																																																																													
SAS-1-24 Aug. 73-03	16.8	24°S	± 2°	1°S	2.1	10	0°	4																																																																																																																										
	8.1	4°S	± 2°	2°N	3.2																																																																																																																													

Measurements From Pressure Sensors

Visual Observations

SAS Run and Date	Period Sec.	$\alpha_o$ Degrees	$\Delta\alpha_o$ Degrees	$\alpha_b$ Degrees	$H_b$ Feet	Indiv. Period Sec.	$\alpha_b$ Degrees	H Feet
SAS-1-27 Aug. 73-02	16.8	27°S	± 1°	1°S	2.6	15	5°S	2
	9.8	1°S	± 2°	2°N	2.0			
	5.0				1.2			
SAS-1-06 Sept. 73-03	16.8	26°S	± 5°	1°S	3.3	7	5°N	3
	8.8	1°S	± 5°	2°N	3.2			
SAS-1-07 Sept. 73-03	14.2	26°S	± 4°	2°S	4.5	9.6	5°N	4
	8.8	1°S	± 5°	3°N	3.7			
SAS-1-14 Sept. 73-03	14.2	22°S	± 5°	1°S	2.3	11.4	0°	2
	10.9	2°S	± 3°	2°N	2.7			
SAS-1-17 Sept. 73-03	16.8	22°S	± 5°	1°S	2.7	14	5°N	2
	12.3	2°N	± 4°	2°N	2.5			
	5.0				1.3			
SAS-1-18 Sept. 73-03	14.2	20°S	± 4°	1°S	2.4	10	0°	3
	9.8	1°S	± 4°	2°N	2.0			
	6.4				2.1			
SAS-1-19 Sept. 73-03	14.2	21°S	± 4°	1°S	2.1	8.6	0°	3
	6.0	4°S	± 3°	2°N	1.9			
SAS-1-20 Sept. 73-03	14.2	22°S	± 4°	1°S	3.1	8.5	5°N	4
	9.8	1°N	± 3°	2°N	1.7			
	6.4				2.4			
SAS-1-21 Sept. 73-03	12.3	5°S	± 3°	1°N	1.8	8	5°N	5
	7.4	3°S	± 3°	2°N	3.0			

Measurements From Pressure Sensors

Visual Observations

SAS Run and Date	Period Sec.	$\alpha_o$ Degrees	$\Delta\alpha_o$ Degrees	$\alpha_b$ Degrees	$H_b$ Feet	Indiv. Period Sec.	$\alpha_b$ Degrees	$H_b$ Feet
SAS-1-24 Sept. 73-03	10.9	0°	± 3°	2°N	3.0	8	0°	5
	7.4	9°N	± 3°	5°N	3.0			
SAS-1-02 Oct. 73-03	16.8	18°S	± 3°	0°	1.6	8.5	5°S	2
	10.9	17°S	± 4°	1°S	1.9			
	6.4				1.1			
SAS-1-03 Oct. 73-02	16.8	19°S	± 3°	0°	2.2	7.5	5°N	4
	8.1	3°N	± 5°	2°N	2.3			
SAS-1-08 Oct. 73-02	14.2	23°S	± 3°	1°S	1.9	8	5°N	2
	7.4	2°N	± 4°	3°N	2.2			
	5.0				1.6			
SAS-1-09 Oct. 73-02	16.8	26°S	± 2°	1°S	2.4	6	5°N	4
	7.4	5°N	± 5°	3°N	1.9			
SAS-1-10 Oct. 73-03	14.2	26°S	± 2°	1°S	2.1	6.5	5°N	4
	6.9	0°	± 3°	3°N	2.6			
SAS-1-11 Oct. 73-03	14.2	25°S	± 4°	1°S	2.1	8.5	0°	3
	9.8	1°S	± 4°	2°N	1.9			
SAS-1-16 Oct. 73-02	14.2	21°S	± 2°	1°S	3.9	8	0°	3
	5.3	0°	± 3°	3°N	1.5			
SAS-1-19 Oct. 73-03	16.8	22°S	± 1°	1°S	4.2	11.5	5°S	4
	5.0	2°N	± 2°	4°N	1.5			

Measurements From Pressure SensorsVisual Observations

SAS Run and Date	Period Sec.	$\alpha_0$ Degrees	$\Delta\alpha_0$ Degrees	$\alpha_b$ Degrees	$H_b$ Feet	Indiv. Period Sec.	$\alpha_b$ Degrees	$H_b$ Feet
SAS-1-22 Oct. 73-03	14.2 10.9	21°S 2°S	±3° ±3°	1°S 2°N	2.7 3.3	14	5°S	4
SAS-1-23 Oct. 73-03	14.2 7.4	22°S 28°S	±2° ±3°	1°S 2°S	2.6 1.5	12	5°S	3
SAS-1-24 Oct. 73-02	12.3 7.4	5°S 1°N	±3° ±4°	1°N 5°N	4.3 3.0	13	5°N	5
SAS-1-25 Oct. 73-03	16.8 8.8	25°S 3°S	±1° ±3°	1°S 2°N	1.8 3.4	8	5°N	5
SAS-1-26 Oct. 73-02	16.8 9.8 7.4	25°S 2°N	±1° ±2°	1°S 2°N	2.1 1.9 2.0	7.4	5°N	4
SAS-1-29 Oct. 73-02	16.8 12.3 8.1	17°S 2°S	±3° ±2°	1°S 2°N	3.6 2.8 2.9	11.5	5°N	4
SAS-1-02 Nov. 73-02	14.2 8.1	17°S 1°N	±4° ±2°	1°S 2°N	3.9 1.9	7.5	5°N	3
SAS-1-05 Nov. 73-02	16.8 6.0	18°S 1°N	±3° ±2°	0° 4°N	3.5 2.0	14	0°	3
SAS-1-07 Nov. 73-02	12.3 6.0	5°S	±3°	1°N	3.8 1.8	10.3	5°N	4
SAS-1-08 Nov. 73-03	14.2 9.8	25°S 4°S	±3° ±4°	1°S 2°N	2.0 3.0	9	0°	3

Measurements From Pressure Sensors

Visual Observations

SAS Run and Date	Period Sec.	$\alpha_o$ Degrees	$\Delta\alpha_o$ Degrees	$\alpha_b$ Degrees	$H_b$ Feet	Indiv. Period Sec.	$\alpha_b$ Degrees	$H_b$ Feet
SAS-1-09 Nov. 73-03	16.8	24°S	± 2°	1°S	2.2	9	0°	2
	10.9	2°S	± 3°	2°N	2.5			
SAS-1-12 Nov. 73-03	12.3	7°S	± 2°	1°N	4.7	10	5°N	4
	4.1	30°S	± 3°	9°S	4.9			
SAS-1-13 Nov. 73-03	9.8	2°S	± 2°	2°N	4.7	11.3	5°N	6
	5.6				2.0			
SAS-1-03 Dec. 73-02	9.8	3°S	± 2°	2°N	4.7	8.5	0°	2
SAS-1-05 Dec. 73-02	16.8	6°S	± 2°	1°N	3.0	11	0°	2
	8.8	2°N	± 2°	2°N	1.8			
	6.4				1.4			
SAS-1-10 Dec. 73-03	20.5				2.6	12	5°S	3
	14.2	12°S	± 3°	0°	2.6			
	10.9	15°S	± 2°	0°	2.5			
	6.9				1.4			
SAS-1-12 Dec. 73-03	14.2	8°S	± 2°	1°N	3.9	10.7	5°S	6
	4.1	68°S	± 3°	9°S	0.7			
SAS-1-18 Dec. 73-03	14.2	11°S	± 4°	0°	3.6	12	5°S	4
	7.4	43°S	± 4°	5°N	3.0			
SAS-1-19 Dec. 73-03	12.3			0°	3.7	11.6	5°S	4
	8.1			5°N	1.8			
	5.6				1.2			

Measurements From Pressure Sensors

SAS Run and Date	Period Sec.	$\alpha_0$ Degrees	$\Delta\alpha_0$ Degrees	$\alpha_b$ Degrees	$H_b$ Feet	Indiv. Period Sec.	$\alpha_b$ Degrees	$H_b$ Feet	Visual Observations
SAS-1-21 Dec. 73-02	36.6 14.2 6.4	13°S 33°N	± 4° ± 3°	0° 7°N	2.4 5.6 1.1	11.8	5°S	6	
SAS-1-02 Jan. 74-03	16.8 8.1	17°S 14°N	± 4° ± 4°	0° 5°N	4.3 2.4	8	5°N	5	
SAS-1-03 Jan. 74-02	14.2 8.8	25°S 4°S	± 4° ± 2°	2°S 1°N	4.5 2.1	11.8	5°N	4	
SAS-1-08 Jan. 74-03	8.8	18°S	± 4°	1°S	5.2	9.2	8°S	6	
SAS-1-09 Jan. 74-02	8.8	30°S	± 5°	4°S	4.8	8	5°S	4	
SAS-1-10 Jan. 74-03	20.5 9.8	17°S 13°S	± 3° ± 3°	0° 0°	3.9 2.8	15.5	5°S	6	
SAS-1-11 Jan. 74-03	14.2 7.4	15°S 23°S	± 3° ± 4°	0° 2°S	3.4 1.3	16	5°S	6	
SAS-1-14 Jan. 74-02	14.2	9°S	± 3°	1°N	5.9	13	5°S	6	
SAS-1-15 Jan. 74-03	12.3	8°S	± 2°	1°N	4.2	12.7	5°S	5	
SAS-1-28 Jan. 74-03	14.2 6.9	5°S 0°	± 3° ± 4°	1°N 1°N	4.5 1.7	10	0°	3	
SAS-1-29 Jan. 74-03	14.2 9.8	10°S 4°N	± 3° ± 3°	0° 1°N	3.7 3.1	9.7	5°N	4	
SAS-1-30 Jan. 74-03	14.2 6.9	9°S 8°N	± 3° ± 3°	0° 4°N	2.7 2.3	14.5	5°N	4	

Measurements From Pressure Sensors

Visual Observations

SAS Run and Date	Period Sec.	$\alpha_o$ Degrees	$\Delta\alpha_o$ Degrees	$\alpha_b$ Degrees	$H_b$ Feet	Indiv. Period Sec.	$\alpha_b$ Degrees	$H_b$ Feet
SAS-1-11 Feb. 74-03	14.2	4°S	± 2°	2°N	5.8	13.2	5°N	5
	6.9	5°S	± 3°	2°N	1.8			
	5.0	11°S	± 3°	0°	1.3			
SAS-1-12 Feb. 74-02	16.8	8°S	± 1°	2°N	2.8	15	5°N	6
	12.3	5°S	± 1°	1°N	4.0			
	5.3				1.5			
SAS-1-26 Feb. 74-02	14.2	10°S	± 3°	1°N	3.8	11	0°	2
	6.0	4°N	± 2°	4°N	2.1			
SAS-1-27 Feb. 74-02	12.3	5°S	± 2°	1°N	3.4	8.5	0°	3
	6.9	6°N	± 2°	5°N	2.9			
SAS-1-07 Mar. 74-03	9.8	4°S	± 2°	1°N	1.9	8	0°	2
	6.4	78°N	± 4°		1.7			
	4.8				1.4			
SAS-1-22 Mar. 74-03	12.3	11°S	± 2°	0°	3.0	12.5	5°S	2
	5.0	13°N	± 4°	5°N	0.9			
SAS-1-26 Mar. 74-02	16.8	12°S	± 4°	2°N	6.3	12.3	5°S	4
	8.8	9°S	± 3°	0°	3.2			
	6.0				1.6			
SAS-1-27 Mar. 74-03	14.2	11°S	± 4°	0°	7.3	15.5	0°	7
SAS-1-28 Mar. 74-03	12.3	8°S	± 4°	1°N	5.8	15	0°	7

Measurements From Pressure Sensors

Visual Observations

SAS Run and Date	Period Sec.	$\alpha_o$ Degrees	$\Delta\alpha_o$ Degrees	$\alpha_b$ Degrees	$H_b$ Feet	Sec.	$\alpha_b$ Degrees	$H_b$ Feet
SAS-1-29 Mar. 74-03	36.6	7°S	± 4°	1°N	2.7	14	0°	6
	14.2				7.8			
SAS-1-01 Apr. 74-03	12.3	4°S	± 3°	2°N	5.8	12.1	0°	6
	8.1				3.8			
SAS-1-03 Apr. 74-03	9.8	6°S	± 2°	2°N	6.5	7	0°	6
SAS-1-04 Apr. 74-02	16.8	21°S	± 1°	1°S	3.9	11.5	0°	5
	8.8				4.2			
SAS-1-05 Apr. 74-02	14.2	14°S	± 3°	0°	4.1	10.7	0°	3
SAS-1-15 Apr. 74-03	14.2	18°S	± 3°	1°S	3.4	11.1	5°N	2
SAS-1-16 Apr. 74-03	12.3	3°S	± 3°	2°N	4.4	8.4	5°N	4
	6.0				2.1			
	4.3	5°N	± 4°	4°N				
SAS-1-17 Apr. 74-03	10.9	7°S	± 2°	1°N	3.0	12	0°	4
	4.3				0.8			
SAS-1-18 Apr. 74-03	14.2	6°S	± 1°	1°	2.8	14.1	0°	4
	10.9				1.7			
	5.3	10°S	± 3°	0°	1.7			
SAS-1-22 Apr. 74-03	20.5	9°S	± 3°	0°	1.6	14.5	5°N	2
	14.2				2.8			
	4.8	9°S	± 3°	0°	1.3			



Measurements From Pressure Sensors

Visual Observations

SAS Run and Date	Period Sec.	$\alpha_o$ Degrees	$\Delta\alpha_o$ Degrees	$\alpha_b$ Degrees	$H_b$ Feet	Indiv. Period Sec.	$\alpha_b$ Degrees	$H_b$ Feet
SAS-1-23 Apr. 74-02	16.8	2°S	± 1°	1°N	3.2	15	5°N	2
	10.9	6°S	± 3°	1°N	2.5			
	4.8				0.9			
SAS-1-24 Apr. 74-02	14.2	7°S	± 3°	1°N	4.2	14	0°	2
SAS-1-25 Apr. 74-03	10.9	4°S	± 3°	2°N	4.2	8	0°	4
	6.4	2°N	± 4°	4°N	2.5			
SAS-1-26 Apr. 74-02	16.8	26°S	± 2°	1°S	2.4	8.5	5°N	4
	10.9	3°S	± 4°	1°N	2.4			
	7.4				3.5			
SAS-1-29 Apr. 74-03	10.9	1°S	± 3°	2°N	3.0	8.5	5°N	4
	6.9	7°N	± 4°	4°N	1.7			
SAS-1-30 Apr. 74-03	12.3	7°S	± 3°	1°N	2.6	8.5	5°N	3
	5.3	3°N	± 5°	5°N	2.4			
SAS-1-01 May 74-03	12.3	5°S	± 3°	1°N	3.2	8	5°N	3
SAS-1-02 May 74-03	14.2	25°S	± 2°	1°S	2.3	9	5°N	4
	10.9	4°S	± 3°	1°N	2.8			
SAS-1-06 May 74-02	16.8	22°S	± 2°	1°S	3.3	12	5°N	4
	5.3	6°N	± 3°	4°N	1.6			
SAS-1-08 May 74-03	12.3	6°S	± 3°	1°N	2.9	12	5°N	2
	6.4	7°N	± 2°	4°N	1.4			

Measurements From Pressure SensorsVisual Observations

SAS Run and Date	Period Sec.	$\alpha_o$ Degrees	$\Delta\alpha_o$ Degrees	$\alpha_b$ Degrees	$H_b$ Feet	Indiv. Period Sec.	$\alpha_b$ Degrees	$H_b$ Feet
SAS-1-13 May 74-03	16.8	25°S	1°	1°S	2.9	11.5	5°N	4
	12.3	3°S	3°	1°N	3.3			
	8.8				3.4			
SAS-1-16 May 74-02	14.2	11°S	3°	0°	4.4	11	5°N	4
	8.8	2°N	2°	3°N	3.2			
	6.0				1.9			
SAS-1-17 May 74-03	12.3	4°S	3°	1°N	3.2	8	5°N	6
	7.4	3°S	2°	3°N	3.8			
SAS-1-21 May 74-02	14.2	23°S	2°	1°S	0.8	8.5	5°N	3
	8.1	0°	2°	3°N	3.3			

## APPENDIX F

### PLOTTED BEACH PROFILES

Each beach profile measured during this study was plotted using the computer program described in Appendix G. The plotted beach profiles are reproduced for the first 1400 feet (427 meters) of the profile in this Appendix. Those profiles indicated by an asterisk are plotted to the survey limit because an offshore survey was not carried out.

# TORREY PINES BEACH - NORTH RANGE

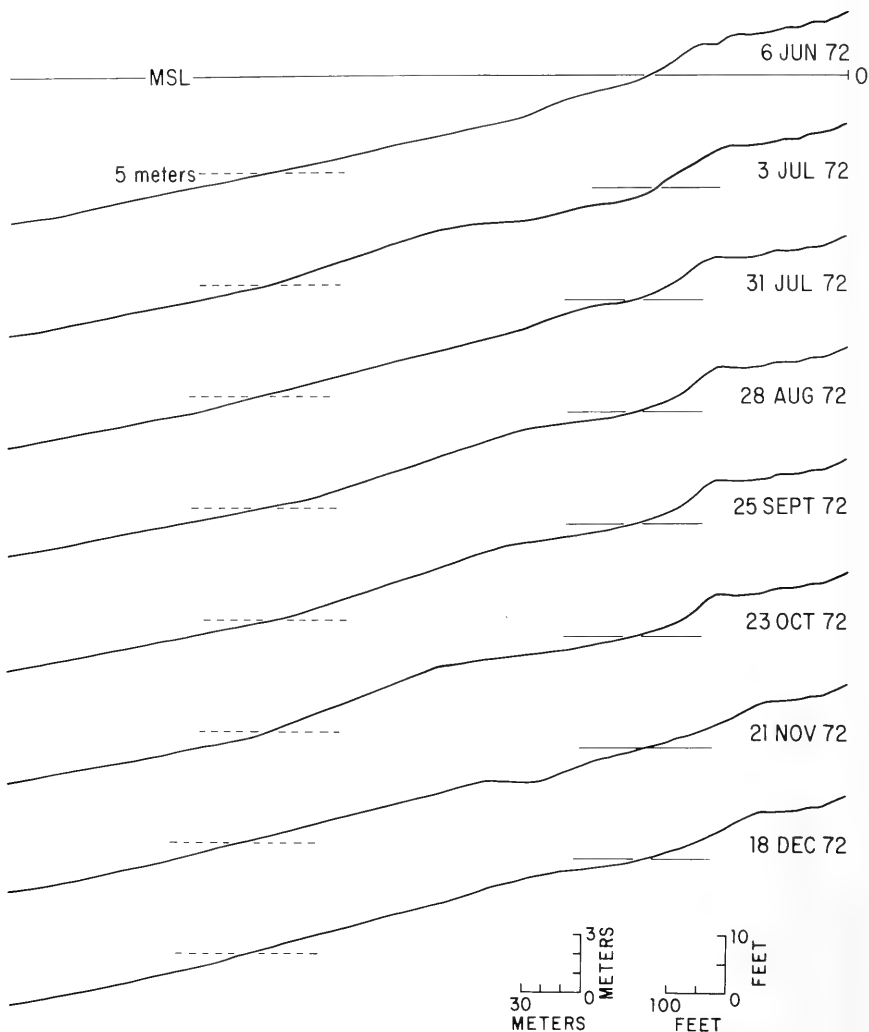

# TORREY PINES BEACH - NORTH RANGE

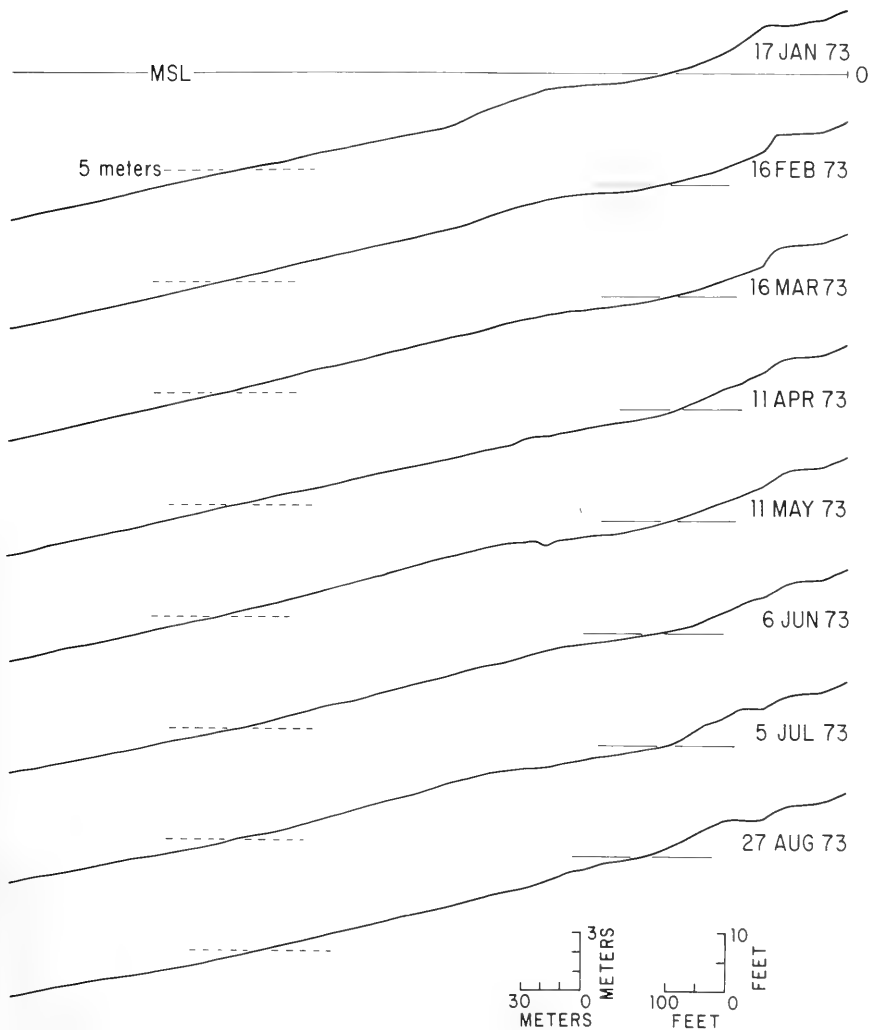

# TORREY PINES BEACH - NORTH RANGE

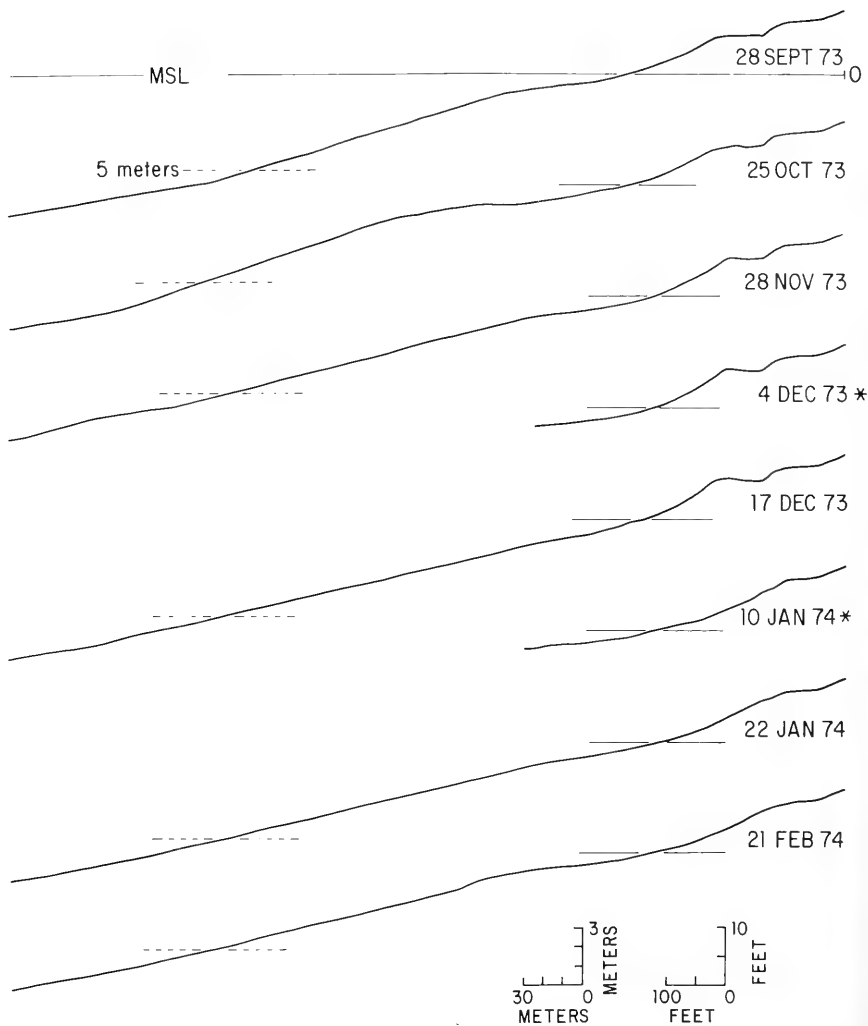

# TORREY PINES BEACH - NORTH RANGE

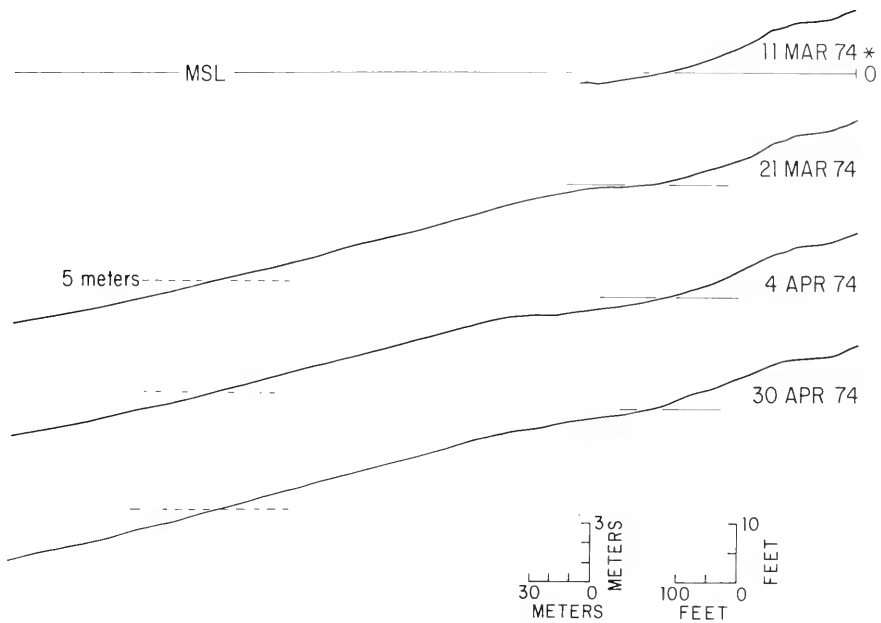

# TORREY PINES BEACH-INDIAN CANYON

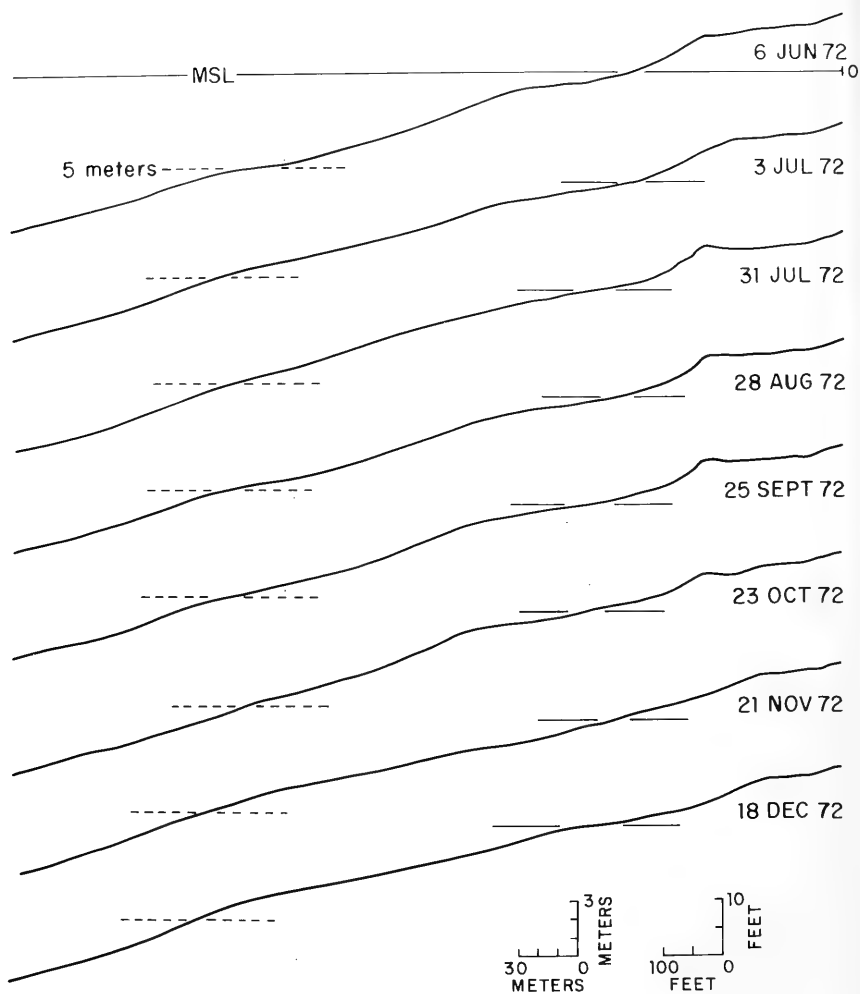



# TORREY PINES BEACH-INDIAN CANYON

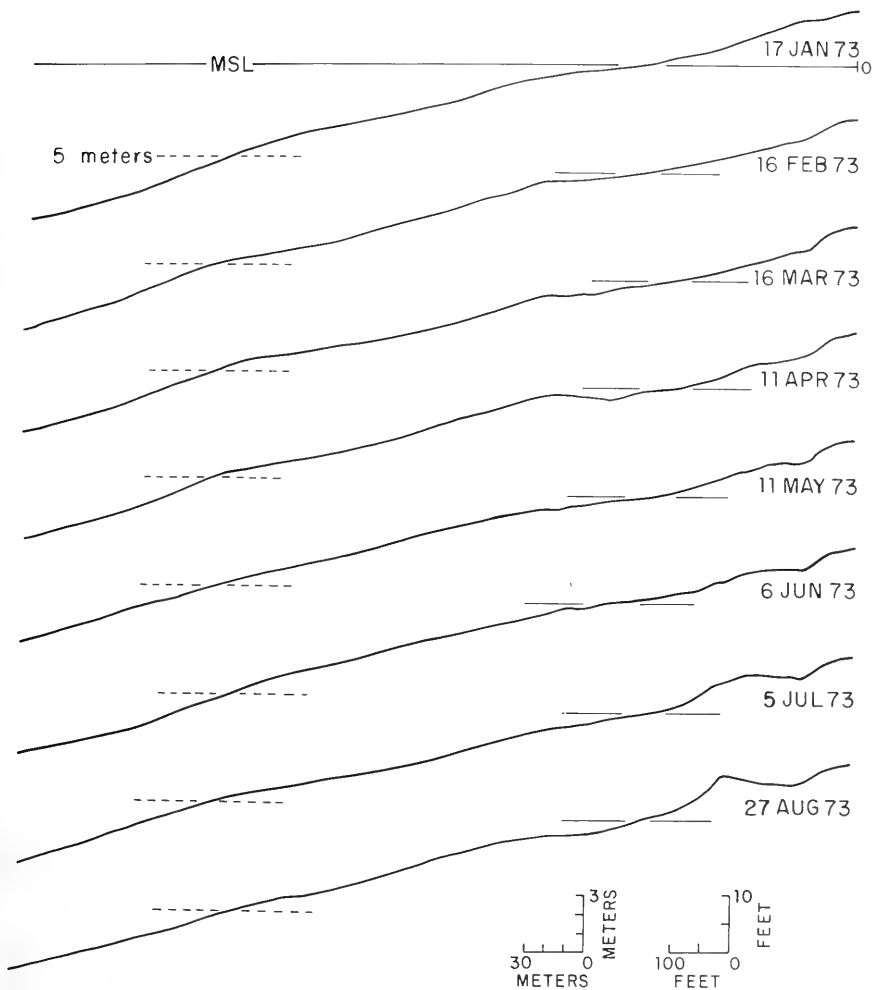

# TORREY PINES BEACH-INDIAN CANYON

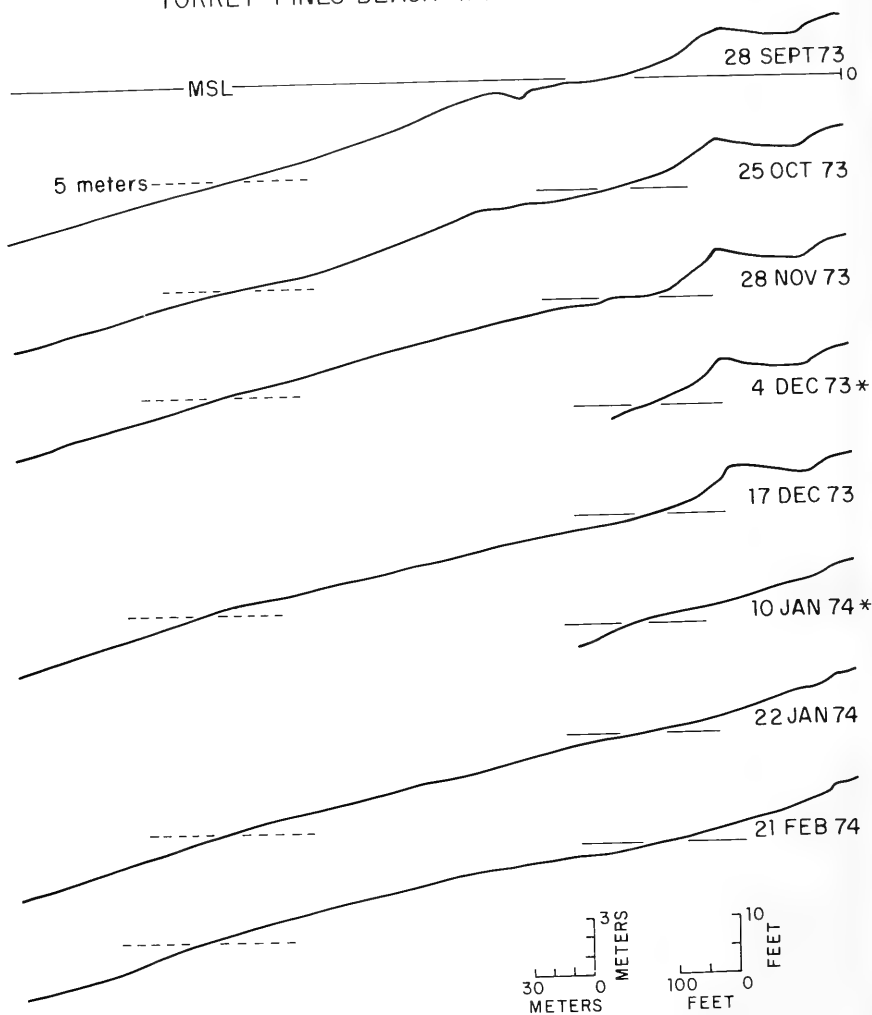

# TORREY PINES BEACH-INDIAN CANYON

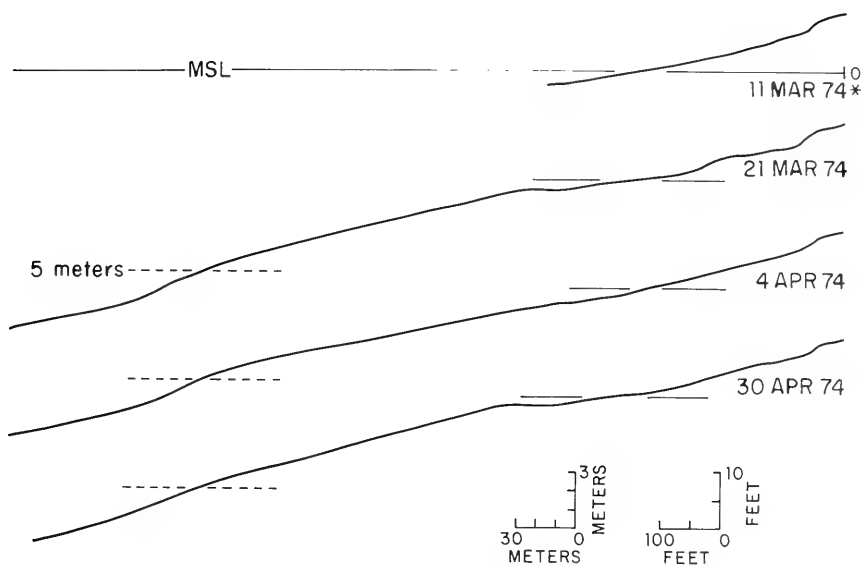

# TORREY PINES BEACH - SOUTH RANGE

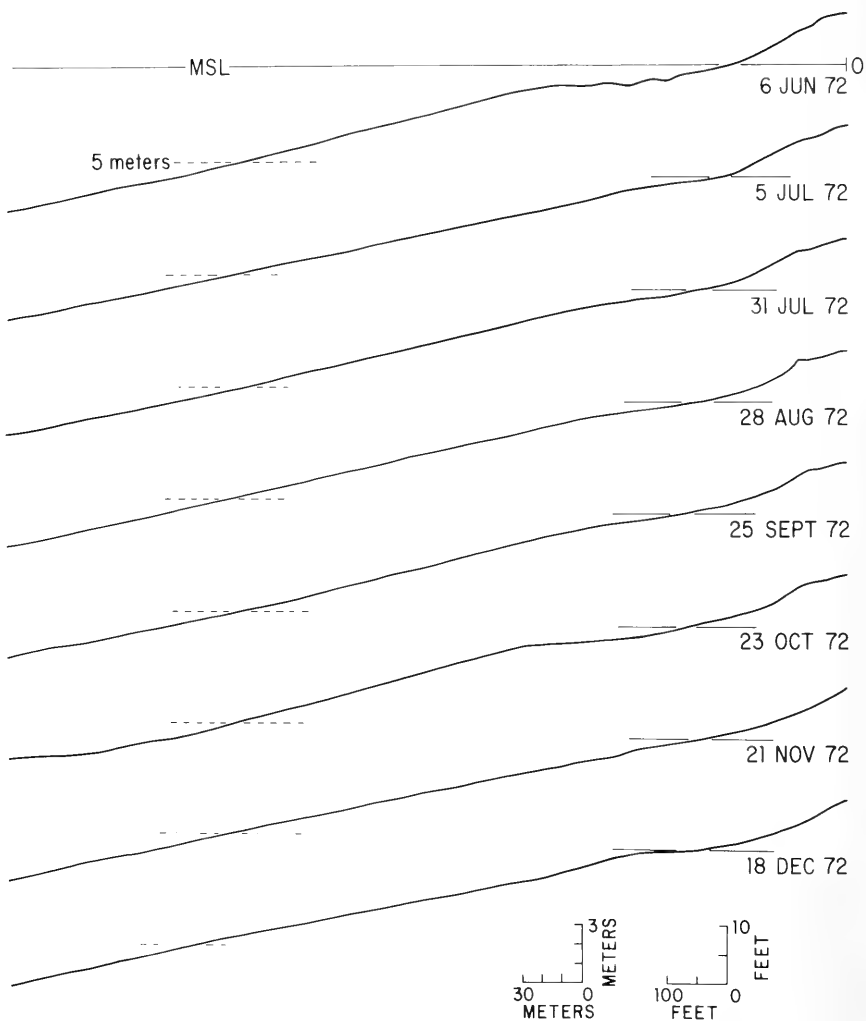

TORREY PINES BEACH - SOUTH RANGE

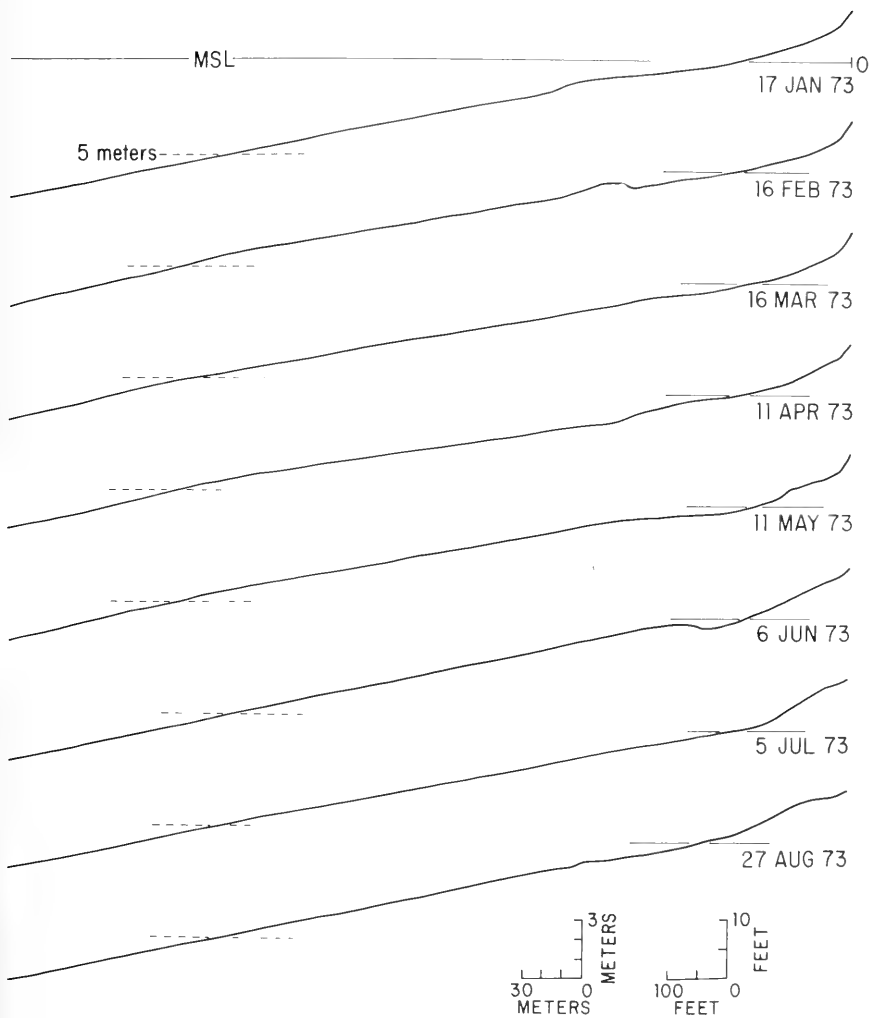

# TORREY PINES BEACH - SOUTH RANGE

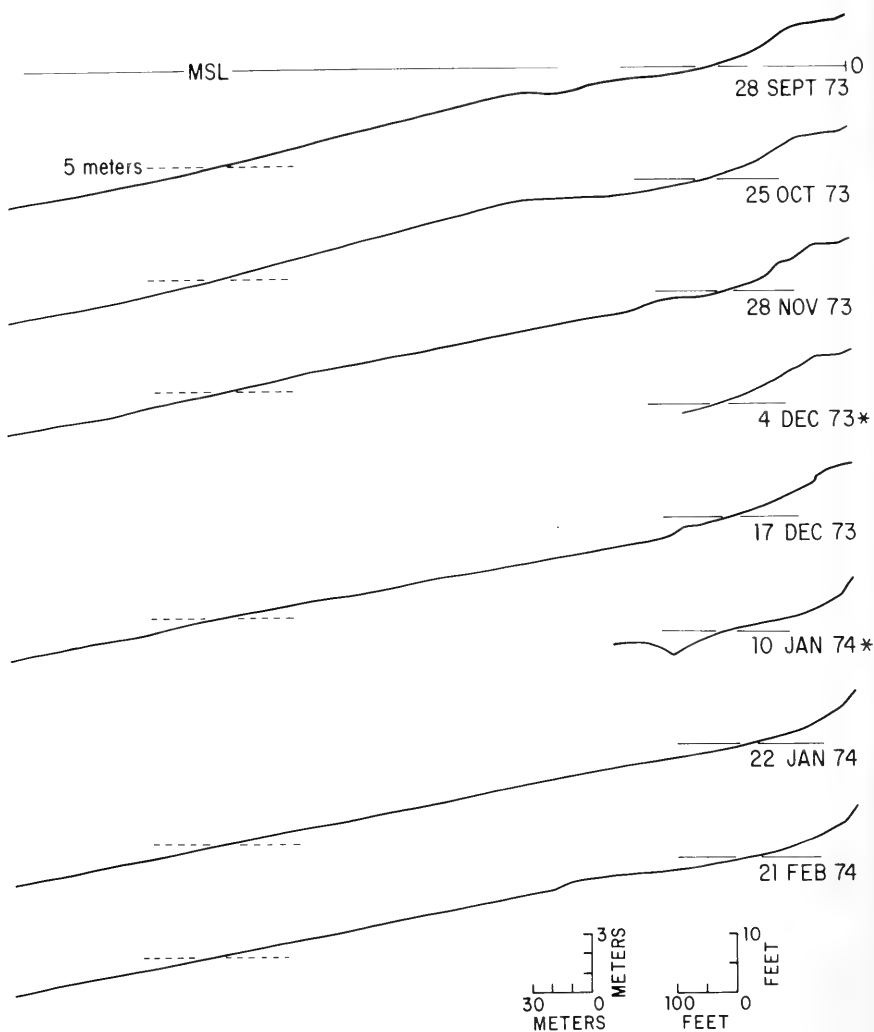

# TORREY PINES BEACH - SOUTH RANGE

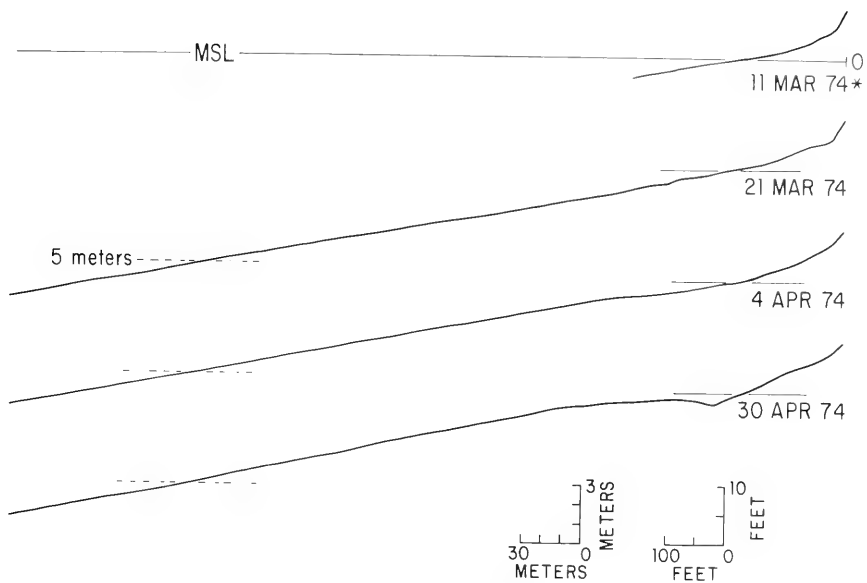

## APPENDIX G

### DESCRIPTION OF THE COMPUTER PROGRAM FOR PLOTTING BEACH PROFILES

This computer program is a simple plotting routine developed to specifically handle beach profile data. The program is written in ALGOL and can handle from 1 to 10 profiles per plot. Using an 11-inch Calcomp pen and ink plotter, the finished plot is 8 inches by 35 inches in dimensions. Scales for the plot are labeled in both metric and English units and have a 10 times vertical exaggeration.

In use the program is stored in a file on the disk storage of the UCSD Burroughs 6700 computer during the time the plots are to be made. Disk storage saves time by having to compile the program only once. Data cards consisting of one x and y coordinate per profile data point and control cards for each survey are then run to make any number or combination of plots. Included below is a description of the program control cards and a complete listing of the program.

#### DESCRIPTION OF PROGRAM CONTROL CARDS

There must be one set of the cards described below for each profile to be plotted.

Card #1 (free format, i.e., each number followed by , )

- (1) N, number of profile data cards
- (2) S, symbol code number to indicate what symbol will be used to mark each set of data
- \* (3) F, flag for whether or not to complete plot with this profile (see code below)

Card #2 (format 2A6)

- (1) key to be printed with symbol in right margin (maximum of 12 characters) Example: 12SEPT72NR  
DATE RANGE

Card #3 3 → 3 + N (format 2F 10.3)

- (1) X, for profile in feet (1st 10 columns)
  - (2) Y, for profile in feet (columns 11-20)
- } must have decimal point

Note: These cards must be arranged in ascending order of X.



\* Code for Program Completion Instruction

- 0 = Plot this X array and complete plot
- 1 = This is the first of several X arrays to be plotted. Do not complete plot yet.
- 2 = This is another X array to be plotted on the existing plot. Do not complete plot yet.
- 3 = This is the final X array to be plotted. Complete plot.

(ALGOL) "PROFILE"  
BURROUGHS/UCSD 86700

BEGIN

FILE CRD(KIND=9,MAXRECSIZE=14);

FILE PRINTER(KIND=6,MAXRECSIZE=22);

\$INCLUDE "PLOTTER/ALGOL"

\$ BIND = FROM PLOTTER/= :

PROCEDURE LINE(XA,YA,N,L,W,H,XM,XP,YM,YP);

VALUE N,L,W,H,XM,XP,YM,YP; REAL N,L,W,H,XM,XP,YM,YP;

ARRAY XA,YA[\*]; EXTERNAL;

PROCEDURE SYMBOL (X,Y,H,S,R,N);

VALUE X,Y,H,R,N; REAL X,Y,H,R,N; ALPHA ARRAY S[\*]; EXTERNAL;

PROCEDURE PLOT(X,Y,P); VALUE X,Y,P; REAL X,Y; ALPHA P; EXTERNAL;

PROCEDURE NUMBER(X,Y,H,Z,R,D);

VALUE X,Y,H,Z,R,D; REAL X,Y,H,Z,R,D; EXTERNAL;

PROCEDURE AXIS(S,Y,TITLE,N,I,R,M,V,T);

VALUE X,Y,N,I,R,M,V,T; REAL X,Y,N,I,R,M,V,T;

ALPHA ARRAY TITLE[\*]; EXTERNAL;

PROCEDURE ENDPLT; EXTERNAL;

PROCEDURE LIMITS(M,N); VALUE M,N; REAL M,N; EXTERNAL;

PROCEDURE PENPOS(X,Y); REAL X,Y; EXTERNAL;

INTEGER ERROR;

REAL ARRAY X[1:200],Y[1:200];

ALPHA ARRAY XCHAR[0:2],YCHAR[0:2],TITL[0:2],KEY[0:1];

INTEGER F,I,N,S;

LABEL RD,EPF,EXIT;

PROCEDURE PLOTDATA(X,Y,N,XMIN,XMAX,YMIN,YMAX,XS,YS,XL,YL,XCHAR,  
YCHAR,TITL,KEY,S.F.);

X=ARRAY OF X COORDINATES

Y=ARRAY OF Y COORDINATES

N=NUMBER OF DATA POINTS TO BE PLOTTED

XMIN=MINIMUM VALUE FOR X-AXIS SCALE

XMAX=MAXIMUM VALUE FOR X-AXIS SCALE

YMIN=MINIMUM VALUE FOR Y-AXIS SCALE

YMAX=MAXIMUM VALUE FOR Y-AXIS SCALE

XS=SPACING OF X,-AXIS SCALE MARKS

YS=SPACING OF Y-AXIS SCALE MARKS

XL=LENGTH OF X AXIS IN INCHES (USUALLY 10 OR 14 INCHES)

YL=LENGTH OF Y AXIS IN INCHES(YL MUST BE 9 INCHES OR LESS)

XCHAR=ARRAY CONTAINING X-AXIS TITLE (MAXIMUM OF 18 CHARACTERS)

YCHAR=ARRAY CONTAINING Y-AXIS TITLE (MAXIMUM OF 18 CHARACTERS)  
 TITL=ARRAY CONTAINING PLOT TITLE (MAXIMUM OF 18 CHARACTERS)  
 KEY=ARRAY CONTAINING KEY (TO BE PRINTED WITH SYMBOL IN MARGIN)  
 S=INTEGER REPRESENTING SYMBOL TO BE USED FOR PLOTTING DATA POINTS  
 F=FLAG FOR NUMBER OF ARRAYS TO BE PLOTTED  
 0=PLOT THIS X ARRAY AND COMPLETE PLOT  
 1=THIS IS THE FIRST OF SEVERAL X ARRAYS TO BE PLOTTED. DO  
 NOT COMPLETE PLOT YET  
 2=THIS IS ANOTHER X ARRAY TO BE PLOTTED ON THE EXISTING  
 PLOT. DO NOT COMPLETE THE PLOT YET  
 3=THIS IS THE FINAL X ARRAY TO BE PLOTTED. COMPLETE PLOT

- NOTES: (1) POINTS THAT EXTEND BEYOND THE GIVEN LIMITS FOR THE AXES  
 ARE PLOTTED ON THE AXES  
 (2) THERE IS ROOM FOR ONLY 5 DIGITS PER NUMBER FOR THE Y-AXIS  
 NUMBERING. LARGER NUMBERS SHOULD BE SCALED ACCORDINGLY.  
 (3) FOR LINEAR Y-AXES YS MUST BE GEQ .0001  
 (4) A MAXIMUM OF 10 PROFILES PER PLOT IS ALLOWED  
 (5) ONLY ONE COMPLETE PLOT PER RUN IS ALLOWED

VALUE YMIN,YMAX,XMIN,XMAX,XS,YS,XL,YL;  
 REAL ARRAY X[1],Y[1],XCHAR[0],YCHAR[0],TITL[0], KEY[0];  
 REAL XMIN,XMAX,YMIN,YMAX,XS,YS,XL,YL;  
 INTEGER N,S,F;  
 BEGIN  
 REAL XMN,XXM, YMN,XXY, XSS,YS, XVV,YVV, XMN1, YMN1;

ALPHA ARRAY XCHAR1[0:2],YCHAR1[0:2];

OWN REAL XV,YV,XM,YM;

OWN REAL ARRAY KEYCHAR[0:10,0:1];

OWN INTEGER NA;

OWN INTEGER ARRAY SYM[0:10];

INTEGER ARRAY SP[0:1];

REAL AJ,TIC,ABA,XX;

REAL E,XC,YC,YY;

INTEGER ND,JJ;

INTEGER I,J,K;

LABEL DIG,DIGY,PTS,EP;

ERROR:=0;

WRITE(PRINTER, <"N=",I5," S=",I5" F=",I5 >,N,S,F);

IF F>1 THEN GO TO PTS;

WRITE(PRINTER,<"XMIN=",E12.5," XMAX=",E12.5," YMIN=",  
 E12.5," YMAX=",E12.5," XS=",E12.5," YS=",E12.5>,XMIN,XMAX,  
 YMIN,YMAX,XS,YS);

IF XL>40 OR YL>9 THEN BEGIN

WRITE (PRINTER,<"PLOT LENGTH OR HEIGHT TOO LARGE- PROGRAM ABORTED">);

ERROR:=1;

GO TO EP; END;

IF XS=0 OR YS=0 THEN BEGIN

WRITE (PRINTER,<"X OR Y AXIS TIC MARK SPACING SET EQUAL TO ZERO-  
 PROGRAM ABORTED">);

ERROR:=1;

GO TO EP; END;

```

PLOT(46,0,"XMAX");
LIMITS(16,1);
PLOT(L,.5,"ORIGIN");
PLOT(0,0,"UP");
PLOT(XL,),"DPWN");
PLOT(XL,YL,"DOWN");
PLOT(0,YL,"DOWN");
PLOT(0,0,"DOWN");
%Y AXIS LABEL
SYMBOL (-.88,.5*YL-1.5,.2 ,YCHAR[*],90,18);
IF YS>0 THEN BEGIN
%LINEAR Y-AXIS
YV:=(YMAX-YMIN)/YL;
FOR I:=0 STEP 1 UNTIL 4 DO IF YS GEQ 10**(-I) THEN GO TO DIGY;
DIGY: ND:=I;
TIC:=-.04;
IF YMAX 999. THEN XX:=-.55-.1*ND ELSE XX:=-.35-.1*ND;
YMN:=YMN1:=YMIN; YMX:=YMAX; YSS:=YS;
FOR K:+0 STEP 1 UNTIL 1 DO BEGIN
YVV:=(YMX-YMN)/YL;
JJ:=ENTIER(YVV/YSS+.99);
J:=0;
FOR YC:=YMN1 STEP YSS UNTIL 1.001*YMX DO BEGIN
YY:=(YC-YMN)/YVV;
PLOT(0,YY,"UP");
IF J MOD JJ=0 THEN BEGIN
PLOT(2*TIC,YY,"DOWN");
NUMBER(XX,YY-.06,.12,YC,0,-1);
END ELSE PLOT(TIC,YY,"DOWN");
J:=J+1;
END;
TIC:=-.04;
XX:=-.1;
YMN:=3.281*YMIN; YMX:=3.281*YMAX; YSS:=YS*2.;
YMN1:=(YMN DIV 10)*10.;
PLOT(XL+1,.5,"ORIGIN");
END;
PLOT(1,.5,"ORIGIN");
END;
FILL YCHAR1(*) WITH "ELEVATION (FT) ";
SYMBOL (XL+1.5,.5*YL-1.5,.2,YCHAR1[*],90,14);
IF XS>0 THEN BEGIN
%PLOT X AXIS LABEL AND TITLE
SYMBOL (.5*XL-1.5,-.8,.2,XCHAR[*],0,18);
SYMBOL (XL-2.5,-1.,.15,TITL[*],0,18);
%LINEAR X-AXIS
XV:=(XMIN)/XL;
FOR I:=0 STEP 1 UNTIL 4 DO IF XS.GEQ 10**(-I) THEN GO TO DIG;
DIG: ND:=I;
XMN:=XMN1:=XMIN; XMX:=XMAX; XSS:=XS;
TIC:=-.04;

```

```

YY:=-.2;
FOR K:=0 STEP 1 UNTIL 1 DO BEGIN
J:=0;
XVV:=(XMX-XMN)/XL;
JJ:=ENTIER(XVV/XSS+.99);
FOR XC:=XMN1 STEP XSS UNTIL XMX DO BEGIN
XX:=(XC-XMN)/XVV;
PLOT(XX,0,"UP");
IF J MOD JJ=0 THEN BEGIN
PLOT(XX,2*TIC,"DOWN");
NUMBER(XX,YY,-.12,-XC,0,-ND);
END ELSE PLOT(XX,TIC,"DOWN");
J:=J+1;
END;
TIC:=-.04;
YY:=-.1;
XMN:=XMIN*3.281; XMX:=XMAX*3.281; XSS:=4*XSS;
XMN1:=(XMN DIV 100)*100.;
PLOT(1,YL+.5,"ORIGIN");
END;
PLOT(1,.5,"ORIGIN");
END;
FILL XCHAR1[*] WITH "DISTANCE (FT) ";
SYMBOL(.5*XL-1.5,YL+.4,.2,XCHAR1[*],0,13);
XM'=XMIN; YM:=YMIN;
%PLOT DATA POINTS
PTS:
FOR I:=1 STEP 1 UNTIL N DO BEGIN
X[I]:=-X[I];
IF YS=0 THEN BEGIN
IF Y[I]>0 THEN Y[I]:=MIN(YMAX,MAX(YMIN,LOG(Y[I]))) ELSE Y[I]:=YMIN;
END ELSE
Y[I]:=MIN(YMAX,MAX(YMIN,Y[I]));
IF XS=0 THEN BEGIN
IF X[I]>0 THEN X[I]:=MIN(XMAX,MAX(XMIN,LOG(X[I]))) ELSE X[I]:=XMIN;
END ELSE
X[I]:=MIN(XMAX,MAX(XMIN,X[I]));
END;
LINE(X,Y,N,10,S,.12,XM,XV,YM,YV);
REPLACE POINTER(KEYCHAR[NA,0]) BY POINTER(KEY) FOR 2 WORDS;
SYM[NA]:=S;
NA:=NA+1;
IF F=0 OR F=3 THEN BEGIN
YY:=YL-.1;
FOR I:=0 STEP 1 UNTIL NA-1 DO BEGIN
SP[0]:=SYM[I];
SYMBOL(XL+2.,YY+.06,.12,SP,0,-3);
SYMBOL(XL+2.5,YY,.12,KEYCHAR[I,*],0,12);
YY:=YY-.3;
END;

```

```

ENDPLT;
END;
EP: END PLOTDATA;

FILL XCHAR[*] WITH "DISTANCE (METERS)";
FILL YCHAR[*] WITH "ELEVATION (METERS)";
FILL TITL [*] WITH "TORREY PINES";
RD: READ(CRD,/,N,S,F);
IF S>33 THEN BEGIN
WRITE(PRINTER,<"INCORRECT SYMBOL - PROGRAM ABORTED">);
GO TO EXIT; END;
IF F<0 OR F>3 THEN BEGIN
WRITE(PRINTER,<"F OUT OF RANGE- PROGRAM ABORTED">);
GO TO EXIT; END;
IF N>200 THEN BEGIN
WRITE(PRINTER,<"N IS TOO LARGE (>200) - PROGRAM ABORTED">);
GO TO EXIT; END;
READ (CRD,<2A6>,KEY[*]);
FOR I:=1 STEP 1 UNTIL N DO BEGIN
READ(CRD,<2F10.3>,X[I],Y[I])(EOF);
X[I]:= .3048*X[I];
Y[I]:= .3048*Y[I];
END;
PLOTDATA(X,Y,N,-1100,0,-20,5,50,5,36.089,8.202,XCHAR,YCHAR,TITL,
KEY,S,F);
WRITE(PRINTER,<"DATA PLOTTED FOR ", 2A6>,KEY[*]);
IF F>0 AND F<3 THEN GO TO RD ;
GO TO EXIT;
EOF: WRITE(PRINTER,<"NUMBER OF PROFILE CARDS DOES NOT EQUAL N - PROGRAM
ABORTED">);
EXIT: END.

```

## APPENDIX H

Sediment analysis data for samples collected from Torrey Pines Beach, California.

Samples Collected 6-9 July 1973:

<u>Sample</u>	<u>Md<math>\phi</math></u>	<u>Md Microns</u>	<u>Sorting <math>\sigma\phi</math></u>	<u>Skewness <math>\alpha\phi</math></u>
<u>South Range</u>				
Beach Face	2.2	218	0.5	0.0
16 ft.	2.7	154	0.5	0.0
24 ft.	3.1	117	0.45	-0.11
33 ft.	3.1	117	0.4	-0.25
<u>Indian Canyon Range</u>				
Beach Face	2.5	177	0.3	0.0
16 ft.	2.6	165	0.5	0.0
24 ft.	2.9	134	0.45	-0.11
33 ft.	3.2	109	0.35	+0.14
45 ft.	3.4	95	0.3	0.0
65 ft.	3.4	95	0.3	0.0
<u>North Range</u>				
Beach Face	2.5	177	0.35	+0.14
16 ft.	2.4	189	0.65	-0.08
24 ft.	3.0	125	0.45	-0.11
33 ft.	3.3	102	0.3	0.0

## Appendix H (Cont'd)

Samples Collected 25-26 February 1974

<u>Sample</u>	<u>Md<math>\phi</math></u>	<u>Md Microns</u>	<u>Sorting <math>\sigma\phi</math></u>	<u>Skewness <math>\alpha\phi</math></u>
<u>South Range</u>				
Beach Face	2.2	218	0.45	+0.11
16 ft.	2.4	189	0.60	-0.17
24 ft.	3.2	109	0.40	0.0
33 ft.	3.3	102	0.30	0.0
<u>Indian Canyon Range</u>				
Beach Face	2.3	203	0.40	0.0
16 ft.	2.4	189	0.40	0.0
24 ft.	3.2	109	0.35	-0.14
33 ft.	3.4	95	0.30	0.0
45 ft.	3.5	88	0.30	-0.33
65 ft.	3.5	88	0.25	-0.20
<u>North Range</u>				
Beach Face	2.1	233	0.50	0.0
16 ft.	2.2	218	0.60	-0.17
24 ft.	3.2	109	0.45	-0.11
33 ft.	3.4	95	0.30	0.0

Note: All samples were analyzed by sieving with 8-inch diameter sieves separated at  $1/2\phi$  intervals. Statistical parameters used to characterize the grain size distribution curves are those of Inman (1952). Samples are from reference rod stations and sample depths are relative to MSL.







<p>Hordstrom, Charles E. Sand level changes on Torrey Pines Beach, California / by Charles E. Hordstrom and Douglas L. Inman. - Fort Belvoir, Va. : U.S. Coastal Engineering Research Center, 1975. 166 p. : ill. (Miscellaneous paper - Coastal Engineering Research Center ; no. 11-75) (Contract - Coastal Engineering Research Center ; DACW72-72-C-0020) Bibliography : p. 34. Report presents profile and sediment data collected during a 23-month survey of beach and offshore sand level changes along a straight beach at Torrey Pines, California. Data showed seasonal changes in beach configuration related to changes in the wave regime. 1. Beach profile. 2. Wave observations. 3. Torrey Pines Beach, Calif. I. Title. II. Inman, Douglas L., joint author. III. Series : U.S. Coastal Engineering Research Center. Miscellaneous paper no. 11-75. IV. Series : U.S. Coastal Engineering Research Center. Contract DACW72-72-C-0020.</p>	<p>TC203 .U581mp no. 11-75 627 .U581mp</p> <p>Hordstrom, Charles E. Sand level changes on Torrey Pines Beach, California / by Charles E. Hordstrom and Douglas L. Inman. - Fort Belvoir, Va. : U.S. Coastal Engineering Research Center, 1975. 166 p. : ill. (Miscellaneous paper - Coastal Engineering Research Center ; no. 11-75) (Contract - Coastal Engineering Research Center ; DACW72-72-C-0020) Bibliography : p. 34. Report presents profile and sediment data collected during a 23-month survey of beach and offshore sand level changes along a straight beach at Torrey Pines, California. Data showed seasonal changes in beach configuration related to changes in the wave regime. 1. Beach profile. 2. Wave observations. 3. Torrey Pines Beach, Calif. I. Title. II. Inman, Douglas L., joint author. III. Series : U.S. Coastal Engineering Research Center. Miscellaneous paper no. 11-75. IV. Series : U.S. Coastal Engineering Research Center. Contract DACW72-72-C-0020.</p>
<p>Hordstrom, Charles E. Sand level changes on Torrey Pines Beach, California / by Charles E. Hordstrom and Douglas L. Inman. - Fort Belvoir, Va. : U.S. Coastal Engineering Research Center, 1975. 166 p. : ill. (Miscellaneous paper - Coastal Engineering Research Center ; no. 11-75) (Contract - Coastal Engineering Research Center ; DACW72-72-C-0020) Bibliography : p. 34. Report presents profile and sediment data collected during a 23-month survey of beach and offshore sand level changes along a straight beach at Torrey Pines, California. Data showed seasonal changes in beach configuration related to changes in the wave regime. 1. Beach profile. 2. Wave observations. 3. Torrey Pines Beach, Calif. I. Title. II. Inman, Douglas L., joint author. III. Series : U.S. Coastal Engineering Research Center. Miscellaneous paper no. 11-75. IV. Series : U.S. Coastal Engineering Research Center. Contract DACW72-72-C-0020.</p>	<p>TC203 .U581mp no. 11-75 627 .U581mp</p> <p>Hordstrom, Charles E. Sand level changes on Torrey Pines Beach, California / by Charles E. Hordstrom and Douglas L. Inman. - Fort Belvoir, Va. : U.S. Coastal Engineering Research Center, 1975. 166 p. : ill. (Miscellaneous paper - Coastal Engineering Research Center ; no. 11-75) (Contract - Coastal Engineering Research Center ; DACW72-72-C-0020) Bibliography : p. 34. Report presents profile and sediment data collected during a 23-month survey of beach and offshore sand level changes along a straight beach at Torrey Pines, California. Data showed seasonal changes in beach configuration related to changes in the wave regime. 1. Beach profile. 2. Wave observations. 3. Torrey Pines Beach, Calif. I. Title. II. Inman, Douglas L., joint author. III. Series : U.S. Coastal Engineering Research Center. Miscellaneous paper no. 11-75. IV. Series : U.S. Coastal Engineering Research Center. Contract DACW72-72-C-0020.</p>



Nordstrom, Charles E.  
 Sand level changes on Torrey Pines Beach, California / by Charles E. Nordstrom and Douglas L. Inman. - Fort Belvoir, Va. : U.S. Coastal Engineering Research Center, 1975.  
 166 p. : ill. (Miscellaneous paper - Coastal Engineering Research Center ; no. 11-75) (Contract - Coastal Engineering Research Center ; DACW72-72-C-0020)  
 Bibliography : p. 34.  
 Report presents profile and sediment data collected during a 23-month survey of beach and offshore sand level changes along a straight beach at Torrey Pines, California. Data showed seasonal changes in beach configuration related to changes in the wave regime.  
 1. Beach profile. 2. Wave observations. 3. Torrey Pines Beach, Calif. I. Title. II. Inman, Douglas L., joint author. III. Series : U.S. Coastal Engineering Research Center. Miscellaneous paper no. 11-75. IV. Series : U.S. Coastal Engineering Research Center. Contract DACW72-72-C-0020.

TC203 .U581mp no. 11-75 627 .U581mp

Nordstrom, Charles E.  
 Sand level changes on Torrey Pines Beach, California / by Charles E. Nordstrom and Douglas L. Inman. - Fort Belvoir, Va. : U.S. Coastal Engineering Research Center, 1975.  
 166 p. : ill. (Miscellaneous paper - Coastal Engineering Research Center ; no. 11-75) (Contract - Coastal Engineering Research Center ; DACW72-72-C-0020)  
 Bibliography : p. 34.  
 Report presents profile and sediment data collected during a 23-month survey of beach and offshore sand level changes along a straight beach at Torrey Pines, California. Data showed seasonal changes in beach configuration related to changes in the wave regime.  
 1. Beach profile. 2. Wave observations. 3. Torrey Pines Beach, Calif. I. Title. II. Inman, Douglas L., joint author. III. Series : U.S. Coastal Engineering Research Center. Miscellaneous paper no. 11-75. IV. Series : U.S. Coastal Engineering Research Center. Contract DACW72-72-C-0020.

TC203 .U581mp no. 11-75 627 .U581mp

Nordstrom, Charles E.  
 Sand level changes on Torrey Pines Beach, California / by Charles E. Nordstrom and Douglas L. Inman. - Fort Belvoir, Va. : U.S. Coastal Engineering Research Center, 1975.  
 166 p. : ill. (Miscellaneous paper - Coastal Engineering Research Center ; no. 11-75) (Contract - Coastal Engineering Research Center ; DACW72-72-C-0020)  
 Bibliography : p. 34.  
 Report presents profile and sediment data collected during a 23-month survey of beach and offshore sand level changes along a straight beach at Torrey Pines, California. Data showed seasonal changes in beach configuration related to changes in the wave regime.  
 1. Beach profile. 2. Wave observations. 3. Torrey Pines Beach, Calif. I. Title. II. Inman, Douglas L., joint author. III. Series : U.S. Coastal Engineering Research Center. Miscellaneous paper no. 11-75. IV. Series : U.S. Coastal Engineering Research Center. Contract DACW72-72-C-0020.

TC203 .U581mp no. 11-75 627 .U581mp

Nordstrom, Charles E.  
 Sand level changes on Torrey Pines Beach, California / by Charles E. Nordstrom and Douglas L. Inman. - Fort Belvoir, Va. : U.S. Coastal Engineering Research Center, 1975.  
 166 p. : ill. (Miscellaneous paper - Coastal Engineering Research Center ; no. 11-75) (Contract - Coastal Engineering Research Center ; DACW72-72-C-0020)  
 Bibliography : p. 34.  
 Report presents profile and sediment data collected during a 23-month survey of beach and offshore sand level changes along a straight beach at Torrey Pines, California. Data showed seasonal changes in beach configuration related to changes in the wave regime.  
 1. Beach profile. 2. Wave observations. 3. Torrey Pines Beach, Calif. I. Title. II. Inman, Douglas L., joint author. III. Series : U.S. Coastal Engineering Research Center. Miscellaneous paper no. 11-75. IV. Series : U.S. Coastal Engineering Research Center. Contract DACW72-72-C-0020.

TC203 .U581mp no. 11-75 627 .U581mp





