







2

459
A. 241

SCIENCE

A WEEKLY JOURNAL

DEVOTED TO THE ADVANCEMENT OF SCIENCE.

EDITORIAL COMMITTEE : S. NEWCOMB, Mathematics ; R. S. WOODWARD, Mechanics ; E. C. PICKERING, Astronomy ; T. C. MENDENHALL, Physics ; R. H. THURSTON, Engineering ; IRA REMSEN, Chemistry ; J. LE CONTE, Geology ; W. M. DAVIS, Physiography ; O. C. MARSH, Paleontology ; W. K. BROOKS, Invertebrate Zoölogy ; C. HART MERRIAM, Vertebrate Zoölogy ; S. H. SCUDDER, Entomology ; N. L. BRITTON, Botany ; HENRY F. OSBORN, General Biology ; H. P. BOWDITCH, Physiology ; J. S. BILLINGS, Hygiene ; J. MCKEEN CATTELL, Psychology ; DANIEL G. BRINTON, J. W. POWELL, Anthropology.

NEW SERIES. VOLUME II.

JULY TO DECEMBER, 1895.



NEW YORK
41 EAST FORTY-NINTH STREET
1895

THE NEW ERA PRINTING HOUSE,
41 NORTH QUEEN STREET,
LANCASTER, PA.

CONTENTS AND INDEX.

N. S. VOL. II—JULY TO DECEMBER, 1895.

The Names of Contributors are Printed in Small Capitals.

- ABBE, CLEVELAND, Meteorology in the University, 709
Abbot, Henry L., Retirement of, 270
Absorption of Terrestrial Radiation by the Atmosphere, W. M. DAVIS, 485; W. HALLOCK, 523
Adams, Frank D., The Laurentian of Canada, 27
Africa, Expedition to Central, 46
Agassiz, A., Temperature in Lake Superior Copper Mines, 777
Agassiz, Cary Elizabeth, Scholarships, 665
Agricultural, Department Publication Work, 162; Chemistry, H. W. WILEY, 442
Agriculture, Notes on, BYRON D. HALSTED, 12, 68; International Congress of, 132
Agrostology in the Department of Agriculture, F. LAMSON SCRIBNER, 151
Alabama Industrial and Scientific Society, 25; EUGENE A. SMITH, 859
Alcohol, Fifth International Congress for Combatting Abuse of, 342
ALDERSON, VICTOR C., Quaternions, 735
Aleut Baidarkas in Kamchatka LEONHARD STEJNEGER, 62
Alexandrian Museum, 623
Alge, American, Bibliography of, 661
ALLEN, HARRISON, John Adam Ryder, 334; The Structure of Man, R. Wiedersheim, 899
Allen, J. A., On a Collection of Mammals from Arizona and Mexico, C. H. M., 417; List of Mammals Collected in the Black Hills Region of S. Dak., C. H. M., 490
American, Association for the Advancement of Science, 113; The History, Aims and Importance of, F. W. PUTNAM, 171; Lectures at the, 185; Section of Mechanical Science and Engineering, 186; The Springfield Meeting of the, JAS. LEWIS HOWE, 313; Visit to Amherst, 339; Section B, Physics, WILLIAM HALLOCK, 349; Section C, Chemistry, WILLIAM A. NOYES, A. H. GILL, FRANCIS C. PHILLIPS, 354; Section D, Mechanical Science and Engineering, 358; Section A, Mathematics and Astronomy, ASAPH HALL, JR., 397; Section E, Geology and Geography, EDMUND OTIS HOVEY, 399; Section G, Botany, B. T. GALLOWAY, 402; Section I, Economics, 406; Journal of Science, 26, 139, 599, 777; Museum of Natural History, New West Wing, 408; Objects in Nephrite, 129; University of Washington, Gift to, 301
Americanists, Eleventh International Congress of, 300; GEORGE BRUCE HALSTED, 683
Americans Elected Members of British Assoc., 482
Anatomy, of the Central Nervous System, 160; At the Brit. Med. Assoc., 269; and Surgery, St. Petersburg Museum, 805
Ancient Mexican Mosaic Work, 800
ANDREWS, E. A., The Structure of Protoplasm, 893
Angle-worms for Agriculture, 624
Angot, Alfred, Les Aurores Polaires, A. M., 107
Ångström, Knut, Photographically Registering the Infra Red Energy Spectrum, 419
L'Année psychologique, E. B. DELABARRE, 51
Antarctic Exploration, 162, 269, 480, 768, 805
Antidromic Problems, G. MACLOSKE, 681
Anthropological Association, German, 1894, 128; American Subjects at the, 128; Society of Washington, GEORGE R. STETSON, 857
Anthropology, Current Notes on, 8, 56, 128, 265, 726, 766, 800, 845, 887, D. G. BRINTON, in Harvard University, 72; The Aims of, D. G. BRINTON, 261
Anthropometric Measurements, 518
Apáthy, Prof., Cells in Invertebrates and Vertebrates, 571
Apparatus for Collecting Samples of Water at Various Depths, G. C. WHIPPLE, 841
Archæological, School at Cairo, Gift to, 269; Discoveries at Bath, 625; Explorations in Mexico, 689
Arctic Expedition, of 1895 and Lieutenant Peary's Work, ROLLIN D. SALISBURY, 457; Jackson-Harmsworth, 483, 624
Arendt, Rudolf, Bildungselemente und erzieherischer Wert des Unterrichts in der Chemie, E. H. K., 165
Argon, 103, and Helium, 407
ARMSTRONG, Jr., A. C., Lehrbuch der allgemeinen Psychologie, Dr. Johannes Rehmke, 275
Arnold Aboretum, Addition of Land, 71
ARTHUR, J. C., Development of Vegetable Physiology, 360
Arthur, J. C., 'Distinction between Animals and Plants, 404
Ashmead, Rhopalosomidæ, 564
L'Association française pour l'avancement des sciences, 47
Astronomical, Photography, 8; Society, The Royal, 70; and Physical Society of Toronto, 104, 111; Observations Mt. Blanc, 269; Expedition of Amherst College, 732; H. J., 845
Astronomie und Geophysik, Jahrbuch der, 11
Astronomischen Gesellschaft, 848
Astronomy, Notes on the Progress of, during the year 1894; J. K. REES, 5; in Chicago University, 74; A Course for Engineering Students, GEORGE C. COMSTOCK, 502; at the University of Wisconsin, 731
Astrophotographic Work to be carried out at Columbia College Observatory, HAROLD JACOBY, 724
Astrophysical Journal, 83, 383

- Atkinson, Geo. F., *Colletotrichum lindemuthianum*, 157
- Atlanta Exposition, 162, 232, 270, 519, 848
- Atmosphere, The Upper Region of, 44; Studies of the Upper, 131
- Atwater, W. O., Some Points connected with the Chemistry and Physics of Metabolism 357
- Auk, Egg of the Great, 104
- AUSTEN, PETER T., The Science of Examining, 223
- Australasian Association for the Advancement of Science, 184
- B., L. A., Magnetic Resurvey of Austria and Hungary, 737
- BACHE, R. MEADE, Causes of the Gulf Steam, 88
- Bache, R. Meade, Reaction-time according to Race, 818
- Bacteriological Laboratory of Glasgow, 768
- Bacteriologists, Meeting of, 72
- BAILEY, L. H., What is High Work? 164; The Elements of Botany, Francis Darwin, 774; Horticulture at Cornell, 831
- Bailey, L. H., Variation after Birth, 404
- Bailey, S. I., Disks of Jupiter's Satellites, 384
- BAKER, FRANK, Atlas d'ostéologie, Ch. Deberie, 854
- Baker, Frank, Nomenclature of Nerve Cells, 778
- BAKER, FRANK C., Geographical Distribution of the Mollusca, 179; A Reply, 693
- Baker, Ira O., Specifications for Text-books, 392
- Baker, Marcus, Alaska and her Boundary, 821
- BALDWIN, J. MARK, Consciousness and Evolution, 219; Experimental Psychology in America, 627
- Baldwin, J. Mark, Origin of a Thing and its Nature, 818
- Ball and Nozzle Phenomenon, WILLIAM HALLOCK, 121
- Ball, Sir Robert, Life on the Planets, 14
- Ballooning in Germany, 266
- Balm for Wounded Authors and Proof-readers, THEO. GILL, 105
- Bancroft, W. D., Saturated Solutions and the Mass Law, 355; Ternary Mixtures, 419, 817
- Barbour, E. H., Demonelex, 84
- BARNES, CHARLES R., Botanical Society of America, 448
- Barus, Carl, The Countertwisted Curl Aneroid, 639; Filar Anemometer, 639
- Bather, F. A., Braccioerinus and Herpetocrinus, 492
- Bathymetry of the English Lakes, 514
- BAUER, L. A., Meteorologie und Erdmagnetismus, 192; Magnetic Declination in Alaska, 340
- Bauer, L. A., On the Secular Motion of a Free Magnetic Needle, 194
- BEALE, LIONEL S., The Foundations of Medical Science, 644
- Beddard, Frank E., A Text-book of Zoogeography, THEO. GILL, 272; A Monograph of the Order of Oligocheta, W. MCM. WOODWORTH and FRANK SMITH, 696
- Beecher, Charles E., Larval Stages of Trilobites, 383
- Benedikt, Dr. R., Chemical Analysis of Oils, Fats and Waxes, JOSEPH P. GRABFIELD, 138
- Benjamin, C. H., The Place of Drawing and Shop Work in Engineering Schools, 392
- van Bemmel, Prof., Testudinate Reptiles, 573
- Berea College, Dr. Pearson's gift to, 47
- Berlin Academy of Sciences, 30, 231, 268
- Berthelot, Argon, 70
- Beyer, Henry G., The Growth of U. S. Naval Cadets, FRANZ BOAS, 344
- Bibliographia Zoologica and Anatomica, 621, 656
- Bibliographical, Bureau, A Few More Words in regard to the New, HERBERT HAVILAND FIELD, 552; Classification, 731
- Bibliographies of the Sciences, 546
- Bibliography, of Scientific Literature, A. RAMSAY, 48; International Congress of, AKSEL G. S. JOSEPHSON, 74; of Science, International Conference, 268; Work of the Royal Society, 849; of North American Paleontology, CHARLES ROLLIN KEYES, 853.
- Bibliotheca Geographica, 10
- BIGELOW, FRANK H., The Status of the Solar Magnetic Problem, 509
- Bigelow, Frank H., Earth as a Magnetic Shell, 140
- BILLINGS, J. S., The Climates and Baths of Great Britain, 453
- Binghamton Academy of Science, 377
- Biological, Association, Marine, 47; Experiment Station of the University of Illinois, 62, 729; Laboratory, Marine, 101; Section of New York Academy of Sciences, BASHFORD DEAN, 742; Society of Washington, F. A. LUCAS, 635, 703, 778
- Biologie der Pflanzen, Friedrich Ludwig, WM. TRELEASE, 21
- Biology, An Introduction to General, Sedgwick and Wilson, T. H. MORGAN, 740
- Birds, International Congress for the Protection of 161
- BLANDFORD, G. F., Hack Tuke Memorial, 50
- Blood Examination in Disease, JOSEPH F. JAMES, 412
- BOAS, FRANZ, The Growth of U. S. Naval Cadets, Henry G. Beyer, 344
- Boas, Franz, Chinook Texts, A. S. G., 309; Tenth Report on the Northwestern Tribes of Canada, ALEX. F. CHAMBERLAIN, 668
- BOLLEY, H. L., Botanical Club of the A. A. A. S., 445
- Bolometric, Investigation in the Infra-Red Spectrum of the Sun, WILLIAM HALLOCK, 174; Investigations, WILLIAM HALLOCK, 344
- BOLTON, H. CARRINGTON, Bibliography as a Feature of the Chemical Curriculum, 440
- Boruttan, H., Conduction of Nervous Impulses, 782
- Boston Society of Natural History, SAMUEL HENSHAW, 780, 902
- BOSTWICK, ARTHUR E., Katydid Orchestration, 666
- Botanic Garden, The New York, G. L. GOODALE, 1; 270, 518
- Botanical Survey of Nebraska, 43; Gazette, 167, 312, 819; Society of America, 230; Club of the A. A. A. S., H. L. BOLLEY, 445; Society of America, CHARLES R. BARNES, 448; Gardens of University of Pennsylvania, 661; Gardens of University of Berlin, 690; Monographs, Field Columbian Museum, 890; U. S. National Herbarium, 890
- Bouvier, M. E. L., Report on Zoological Bibliography, 570
- BOYCE, R. W., and W. A. HERDMAN, On Oysters and Typhoid, 460
- Brachiopoda, American Fossil, CHARLES SCHUCHERT, 722
- Branner, J. C., Rocks in Brazil, 282

- Brehm Cuts Again, ELLIOTT COUES, 735
- BRINTON, D. G., Current Notes on Anthropology, 8, 56, 128, 265, 726, 766, 800, 845, 887; Folk-lore dans les deux mondes, H. de Charencey, 23; Louisiana Folk-tales, Alice Fortier, 23; Veröffentlichungen aus dem Königlichen Museum für Völkerkunde, 110; The New Race in Egyptian History, 227; The Aims of Anthropology, 241; Korean Games, Stewart Culin, 776; Evolution in Art, Alfred C. Haddon, 900; The Hill Caves of Yucatan, Henry C. Mercer, 900.
- British, Museum, Special Trust Funds of, 232; Association for the Advancement of Science, 300, 377, 516; Address of the President, SIR DOUGLAS GALTON (I), 421; (II.), 462
- BRITTON, N. L., Generic name of the Water Weed, 5; Daniel Cady Eaton, 57
- BRITTON, ELIZABETH G., The Natural History of Plants, F. W. Oliver, 634; A traverse le Caucase, Émile Levier, 635
- Brooklyn Institute of Arts and Sciences, 517, 807
- BROOKS, W. K., Science or Poetry, 437, Testimony versus Evidence, 771
- Brown University, Lecture Association, 771; Woman's College, 665
- Bull, Storm, Theses and Degrees, 392
- Burr, Wm. H., Graduate Studies in Engineering Courses, 393
- Butterflies, and Moths of Teneriffe, Mrs. Holt White. SAMUEL HENSHAW, 81; of North America, Edwards, 584
- C., J. McK., Psychological Notes, 13, 99; Inverted Image on the Retina, 487
- California, Gift to the University of, 231; Work on Physics, 691; Academy of Sciences Proceedings, 770
- Cambridge University, 48; Calendar, 379.
- Campbell, W. W., Spectroscopic Observations of Mars 83 System of Saturn, 384
- Canyons of the Colorado, J. W. Powell, W J MCGEE, 593
- Card Catalogue of Scientific Literature, F. B. WEEKS, CARHART, H. S., 75; Proceedings of the International Electrical Congress, 525
- Carhart H. S., Investigation of the Rotary Field, 353
- Carib Art and its Significance, 265
- Carleton College, Gift to, 850
- Carnegie, Library, 662; Gift to Williams College, 665
- Castillo, Aguilera y Del, Fauna fossil de la Sierra de Catorce en San Luis Potosi, J. B. WOODWORTH, 739
- Catalogue of Scientific Literature, The International, 154
- Catoctin Belt of Maryland and Virginia, 97
- CATTELL, J. MCKEEN, Consciousness and Evolution, 271; Alleged Suppression of Discussion, 411; Experimental Psychology in America, 627; Inverted Image Once More, 668; Measurements of the Accuracy of Recollection, 761; Mr. Spencer on Tactile Perception and Natural Selection, 852
- Chaco Languages, Affinities of, 845
- CHAMBERLAIN, ALEX. F., Tenth Report of the Northwestern Tribes of Canada, Franz Boas, 668
- Chamberlin, T. C., Glacial Studies in Greenland, 491, 708
- Chandler, S. C., Constant of Nutation, 398; A New Variable of Peculiar Character, 638
- CHANEY, JR., L. W., Glacier in the Montana Rockies, 792
- Charcot, Memorial to, 46, 186
- Charencey, H. de, Folk-lore dans les deux mondes, D. G. BRINTON, 23
- Chemical, Journal American, J. ELLIOTT GILPIN, 27, 111, 599, 741; Industry Society, 231; Relation of the Industries to the Advancement of, WILLIAM McMURTRIE, 283; Curriculum, Bibliography as a Feature of, H. CARRINGTON BOLTON, 440; Literature, The Indexing of, 478; Laboratory, Burned, Rose Polytechnic Institute, 770, at Paris, 805; Society, American, 337, DURAND WOODMAN, 779, 856
- Chemistry, International Congress of Applied, 45; Section C. of the A. A. S., 229; Third Annual Congress of Teachers of, 848
- CHEVALIER, S. J. STANISLAUS, Meteorological and Magnetical Observatory, Zi-ka-Wei, 17
- Chicago University, Pres. Harper's Quarterly Statement, 47
- Chinese, Literature, Catalogue of, 662; Culture, Alleged Western Origin of, 726
- Chinook Texts, Franz Boas, A. S. G., 309
- Cholera, 409, 518
- Clark, W. B., Eocene Fauna of Middle Atlantic Slope, 279
- Claypole, E. W., Actinophorus Clarki, Newberry, 55
- Claypole, E., Glacial Notes from Planet Mars, 196
- Clements, J. Morgan, Volcanics of Michigamme District, 708
- Climate, and Health, 690; and Baths of Great Britain, J. S. BILLINGS, 454
- Coal Fields of Newfoundland, 890
- COCKRELL, THEO. D. A., Inaccurate Zoölogy, 556
- Colors, The Measurement of, C. L. F. 893
- Columbia, College, Annual Report of President Seth Low, 586; gift of Mrs. C. A. Atwill, 588
- Columbian University, gifts to, 15
- Comet, 5; discovered at Lick Observatory, 731; W. R. Brooks, 770
- Comparative Neurology, 160
- Composite Origin of Topographic Forms, 374
- COISTOCK, GEORGE C., A Course in Astronomy for Engineering Students, 502
- CONN, H. W., Louis Pasteur, 601
- Consciousness, and the Origin of Species, 100; and Evolution, J. MARK BALDWIN, 219; J. MCKEEN CATTELL, 271; and Volition, Professor Brooks on, E. D. COPE, 521
- Consequences, a Test of Truth, JOSEPH LE CONTE, 379
- Conway, William Martin, The Alps from End to End, W. M. D., 526
- Cook, O. F., Insect Collecting in Africa, 563; Personal Nomenclature, 405
- COPE, E. D., The Present Problems of Organic Evolution, 124; Professor Brooks on Consciousness and Volition, 521
- Cope, E. D., Evolution, 56; Variation, 70; Primary Factors of Evolution, 408; Cotylosauria, 637; A Bone Cave at Port Kennedy, Pa., 638
- Cornell University, Appointments, 15
- Correction, EUGENE A. SMITH, 107; THEO. GILL, 343
- Correspondence, 15, 48, 74, 105, 134, 164, 188, 234, 271, 303, 342, 379, 411, 453, 485, 521, 552, 588, 626, 665, 692, 734, 771, 808, 850, 893
- Corthell, Elmer L., The Engineer of the Twentieth Century, 393; Growth of Great Cities, 407; The Tehuantepec Route, 820
- COUES, ELLIOTT, Katydid Orchestration, 666; The Brehm Cuts Again, 735

- Coville, Frederick V., The Nomenclature Question, 167; Botany of Yakutat Bay, 404; Life of Thomas Coulter, 703
- Craigin, F. W., The Mentor Beds, 383
- CRANE, AGNES, The Submergence of Western Europe Prior to the Neolithic Period, 2
- Craniology, Is it a Science? 8; Latest Words in, 766
- Crehore, A. C. and G. O. Squier, Velocity of Projectiles, 195
- Crew, H., and O. H. Basquin, Magnesium Band, Spectrum of Carbon, 384
- Crinoids, a Monograph of, 41
- Critical Periods in the History of the Earth, Joseph Le Conte, ARTHUR HOLLICK, 670
- Crosby, W. O., Tables for the Determination of Common Minerals, LEA MCL. LUQUEER, 738
- Cross, Whitman, The Laccolitic Mountain Groups of Colorado, Utah and Arizona, J. B. WOODWORTH, 700
- Crying with Two Ears, W. H. FISHBURN, 556
- Cuba, Physiography of, 10
- Culin, Stewart, Korean Games, D. G. BRINTON, 771
- Culver, Miss, Gift to Chicago University, 849, 892
- Cushman, Holbrook, Unpublished Papers by, W. HALLOCK, 757
- D., W. M., The Alps from End to End, William Martin Conway, 526; Maj. James Rennell and The Rise of Modern English Geography, Clements R. Markham, 559
- DALL, W. H., St. Elias Bear, 87; Marine Mollusks of Japan, Henry A. Pilsbry, 855
- Dall, W. H., Mammoth Bones Found near the Mouth of Naknek River, 635
- DANA, CHARLES L., The Female Offender, Cæsar Lombroso and William Ferrero, 164; The Etiology of Osseous Deformities, Eugene A. Talbot, 239
- Dana, Edward S., Minerals and How to Study them, S. L. PENFIELD, 773
- Dana, James Dwight, and His Work, 491; Memorial to, 46
- Darwinism of Darwin and of the Post-Darwinian Schools, 527
- Darwin, Francis, The Elements of Botany, L. H. BAILEY, 774
- Dastre, A., Fibrin Dissolved in Solutions of Neutral Salts, 784
- Davenport Academy of Natural Sciences, 584
- Davenport, George E., Daniel Cady Eaton, 312
- DAVIS, W. M., Current Notes on Physiography, 10, 39, 97, 228, 266, 373, 514, 617, 657, 687, 727, 767, 885; Absorption of Terrestrial Radiation by the Atmosphere, 485, Winds and Ocean Currents, 342
- Davis, W. M., The Bearing of Physiography on Uniformitarianism, 280; Notes on Geological Excursions, 744; Theories of Ocean Currents, 824; Deaf and Dumb, Conference of, 231
- DEAN, BASHFORD, New York Academy of Sciences, 742
- Dean, Bashford, Embryology of North American Ganoids, 573; Notes of the Ancestral Sharks, 742
- Deaths, C. C. Babington, 133; E. H. Baillou, 133; H. A. Bardeleben, 483; Ernest Baumann, 483; M. S. Bebb, 890; Philipp Bertkau, 691; E. Whitney
- Blake, 483; S. C. Booth, 451; Oscar Borehert, 770; H. H. Boyeson, 483; Dimitri Brândza, 586; Dr. J. S. Bristowe, 341; E. P. L. Brock, 732; Robert Brown, 622; E. W. Bull, 484; James Carter, 483; Antonio del Castillo, 891; Dr. T. H. Chandler, 300; Edward Combes, 770; Holbrook Cushman, 586; Julius Deby, 104; Joseph Derenbourg, 188; G. E. Dobson, 770; Daniel Cady Eaton, 45; O. E. Ehler, 770; W. Fabritius, 360; J. E. Garretson, 622; Adolf Gerstäcker, 233; E. J. Glave, 15; Dr. von Geiseit, 188; Gustav von Grofe, 233; D. G. Hatch, 163; Herman Hellriegel, 663; Father Hurst, 663; T. H. Huxley, 14; W. C. Jarvis, 163; Thomas Keith, 585; Dr. Kiener, 232; G. Krabbe, 849; Baron Larray, 623; Jules Laverrière, 409; George Lawson, 690; Svenon Louis Loven, 341; S. Moos, 232; Marshall McDonald, 341; D. W. McGee, 133; H. W. Meyer, 46; Frederick Miescher, 409; Mr. Mummery, 409; Dr. Münch, 340; Albert Nagel, 232; J. A. Overbeck, 710; T. O. Paine, 849; E. von Rebeur-Paschwitz, 586; A. L. Pihl, 232; W. A. Pike, 623; O. M. Poe, 483; F. L. Pope, 550; W. N. Popoff, 849; G. H. Porter, 46; C. V. Riley, 407; Ernst Ritter, 451; Dr. Riva, 586; E. F. Rogers, 483; Victor Rydberg, 483; J. von Schroder, 770; Henry Seebohm, 805; Prof. Hoppe Seyler, 341; J. S. Shaw, 46; G. F. W. Spörer, 163; Dr. Stapf, 663; Carl Steckelman, 731; George Stevens, 188; Ernst de Sury, 409; Heinrich von Sybel, 163; Joseph Thompson, 233; Fr. Tietjen, 46; M. M. Tidd, 270; Sir John Tomes, 188; Norton S. Townshend, 133; A. E. P. Gray, 891; H. Tweedell, 409; Calvert Vaux, 768; P. A. A. S. Verneuil, 46; A. M. Villon, 768; Gustav Wilhelm, 586; Dr. Williamson, 484; W. C. Williamson, 15; Moritz Willkomm, 409; H. Wittmeur, 340; Julius Zupitza, 133
- Debierre, Ch., Atlas d'ostéologie, FRANK BAKER, 854
- Decimal System in Measurement of Time and Angles, 103
- Deep Spot in the Ocean, 518
- Deforesting of Mountains, 728
- Degrees at the University at Paris, 301; at Leipzig, 692
- DELABARRE, E. B., L'Année psychologique, 51
- Delaware Water Gap, 99
- Delmar, F. O. T. bequest, 770
- Demoor, Dr., Preparations of Cerebral Cortex of Dogs, 782
- Dennert, E., Vergleichende Pflanzenmorphologie, JOHNS W. HARSHBERGER, 311
- Development of Vegetable Physiology, J. C. ARTHUR, 360
- Diplomas Counterfeited, 105
- Distribution of Plants and Animals, 767
- Diurnal, Nutation, Determination of the Constants of the, F. FOLIE, 613; Rotation of River Volume and Velocity, 515
- Dogmatism of Science, GEORGE M. GOULD, 554
- Dolbear, A. E., Materialism Untenable, 56
- Dollfus, M., Distribution of Oniscidae, 569
- Doolittle, C. L., The Constant of Aberration, 398
- Dormitories at University of Pennsylvania, 625
- Double, Stars, 7; Refraction in Wood, WILLIAM HALLOCK, 239
- DOUGLAS, A. W., St. Louis Academy of Science, 26, 636, 707, 741, 859

- Drawings, an Easy Method of Making Line Drawings, E. E. SLOSSON, 893
- Dry Dredging in the Mississippian Sea. CHARLES SCHUCHERT, 679
- Dubois, E., *Pithecanthropus erectus*, 574
- Dwight, Thomas, Brain of the Chimpanzee, 769
- Earliest Human Occupants of Atlantic Watershed, 67
- Eaton, Daniel Cady, N. L. BRITTON, 57
- Ebert, H., Solar Radiation, 83
- Eccles, A. Symon, The Practice of Massage, GUY HINSDALE, 672
- Echols, W. H., Differell and Integrell Calculus, 396
- Economics of Engineering Public Works, HENRY N. OGDEN, 539
- Education, Report of the U. S. Commissioner of, 484
- Edwards, W. F., Molecular and Atomic Refractions, 111
- Eimer, Prof., Orthogenesis, 572
- Electrical, Literature, Card Catalogue of, 132; and Anatomical Institutes of University of Brussels, 665; Research, Tendencies of Modern, M. I. PUPIN, 861
- Electric Currents, Alternating, 299; Storm on Mount Elbert, Colo., P. A. WELKER, 305;
- Electro-Therapeutic Association, American, 341; Therapeutists, Convention of, 518
- Electrification and Diselectrification of Air and Other Gases, LORD KELVIN; MAGNUS MACLERN and ALEXANDER GLAT, 433
- Eliot, Charles, Public Forests near Boston, 386
- Embryology in Harvard Medical School, 689
- Emerson, B. K., Geology of Hampshire, Archean — and Cambrian Rock, 400; Geology of Worcester Co., Mass., 400
- Engineering, Education, Society for Promotion of, 268; Notes on, R. H. THURSTON, 292; to Economics, The Relation of, WILLIAM KENT, 321; Education, Society for the Promotion of, 390; Association of Nashville, Tenn, 769
- Engineers, The British Institute of Mechanical, 292; and Architects, The Congress of Sanitary, 298; Natural Science Training for, 450; American Society of Mechanical, 843
- Entomological Society of Washington, L. O. HOWARD, 563, 703
- Equilibrium, Sense of, 99
- Euskuarian Ethnology, 800
- Evermann, Barton W., Fishes of Missouri River Basin, 778
- Evolution, The Present Problems of Organic, E. D. COPE, 124; in Art, Alfred C. Haddon, D. G. BRINTON, 900
- Ewald, R., Spinal Cord, 782
- Examining, The Science of, PETER T. AUSTEN, 223
- Excavations at Delphi, 302; In Mason Co., Ky., 302
- F., C. L., The Measurement of Colors, 893
- Fairchild, H. L., Kame Moraine at Rochester, 55; The Glacial Genesee Lakes, 278
- Fano, E., Reaction-time of the Dog
- Fast Trains in Great Britain and the United States, 299, 802
- Faunal Regions of Australia, 131
- Female Offender, Caesar Lombroso and William Ferrero, CHARLES L. DANA, 164
- FERNOW, B. E., The Providential Functions of Government with Special Reference to Natural Resources, 252
- Ferrero, G., Arrested Mentation, 527
- Fewkes, Walter J., Cliff Ruins in Arizona, 902
- FIELD, HERBERT HAVILAND, A New Bibliographical Bureau for Zoology, 234; The Date of Publication in the Light of the Law of Priority, 303; A Few More Words in Regard to the New Bibliographical Bureau, 552
- FISHBURN, W. H., Crying with Two Ears, 556
- FISKE, THOMAS S., The Second Summer Meeting of the American Mathematical Society, 394
- Flather, J. J., Flow of Steam, 359
- FLEMER, J. A., Topographic Methods, 15; Phototopography, 152
- Flint, Albert S., Results for Stellar Parallax, 398
- Flying Machine, Mr. Maxim's, 157
- FOLI, F., Determination of the Constants of the Diurnal Nutation, 613
- FORBES, S. A., Preliminary Note on a Contagious Insect Disease, 375
- Forbush, E. H., The Gypsy Moth, 386
- Forestry Association, American, F. H. NEWELL, 385; of New Jersey, 662
- Forests, Preservation of, 802
- Formic Acid, Determination of, 112
- Fortier, Alcee, Louisiana Folk-tales, D. G. BRINTON, 23
- Fossil Mammals of Patagonia, 158
- Foster, M., Text-book of Physiology, W. T. PORTER, 381
- Foureaux's Expedition into the Sahara, 228
- FRAZER, PERSIFOR, Zur Psychologie des Schreibens, W. Preyer, 78
- French Association for the Advancement of Science, 297, 623
- Freer, P. C., Tetrinic Acid, 355; Teaching of Organic Preparations, 356
- Fries, Th. M., Contributions to a Biography of Linnaeus, J. A. UDDEN, 814
- Friction, The Phenomena of, 621
- Fungi Exsiccati, Remarks on Some Recent, JOSEPH F. JAMES, 654
- G., A. S., Chinook Texts, Franz Boas, 309; The Life and Traditions of the Red Man, Joseph Nicolas, 310
- Gage, Alfred P., The Principles of Physics, W. LE CONTE STEVENS, 306
- GAGE, SIMON HENRY, The Processes of Life Revealed by the Microscope, 209; Leitfaden für histologische Untersuchungen, Bernhard Rawitz, 455; Science or Poetry, 590
- GALLOWAY, B. T., Section E, Botany, A. A. A. S., 402
- Galloway, B. T., *Ucinula Spiralis*, 403
- GALTON, SIR DOUGLAS, Address before the British Association, 421
- Garden Scholarships of Missouri Botanical Garden, 892
- Gates, Elmer, Mentation, 56
- Gaule, J., Growth of skeletal Muscles, 783
- Generic name of the Water Weed, N. L. BRITTON, 5
- Generic name *Anisonyx* preoccupied, C. HART MERRIAM, 107
- Geographic Society, National, W. F. MORSELL, 743, 820; Monographs, National, 373
- Geographical, School Books, Recent, 39; Congress, Italian, 132; Bibliography, 269; Society, Catalogue of the Library of the Royal, 624; Society, The Royal, 663

- Geography, in Normal Schools, 515; at the British Association, ROBERT HUGH MILL, 545
- Geologic Atlas of the United States, 10, 714, 787
- Geological, Survey, of the United States, 58; of Cape Colony, 549; Field Work, 619; Society of America, 185; Society of America, Seventh Summer Meeting of, J. F. KEMP, 277; Conference of Harvard, T. A. JAGGAR, JR., 705, 743, 822, 858, 903; Exposition of Kansas University, 339
- Geologist, The American, 55, 195, 383, 491, 860
- Geology, at Union University, 301; at the British Association, W. W. WATTS, 493; of N. E. Wyoming, 661; at Johns Hopkins University, 690; Journal of, 491, 707; Field Work of University of Kansas, 729
- Geomorphogeny, J. Lapparent on, 10
- GILBERT, G. K., A Rock Fissure, 117
- GILL, THEO., Balm for Wounded Authors and Proof-readers, 105; A Text-book of Zoogeography, Frank E. Beddard, 272; Corrections, 343
- Gill, Theo., Belone and Sarginos of Aristotle, 703; Early Segregation of Fresh-water Types, 678
- GILPIN, J. ELLIOTT, American Chemical Journal, 27, 111, 599, 741
- Gilson, Prof., Muscular Organs of Owenia, 573
- Glacial Lakes of Western New York, 11; Phenomena between Lake Champlain, Lake George and the Hudson River, G. F. WRIGHT, 673
- Glacier in Montana Rockies, L. W. CHANEY, JR., 792
- GLATFELTER, N. M., Salix Wardi, Bebb, 582
- Glazebrook, R. T., Mechanics (Dynamics), R. S. WOODWARD, 631
- GLEN, L. C., Some Notes on Darlington (S. C.) 'Bays,' 472
- Gooch, F. A., Halogens in Mixed Silver Salts, 26; Carbon Dioxide, 140
- Gomberg on the Action of Inorganic Cyanides on Chlorocaffeine, 27
- GOODALE, G. L., The New York Botanic Garden, 1
- Goodale, G. L., Australasian Vegetation, 780
- GOODE, G. BROWN, The Relationships and Responsibilities of Museums, 197
- Goto, M. S., Ectoparasitic Trematodes, 568
- Göttingen Gesellschaft der Wissenschaften, 231
- Gotch, F., Investigation of the Discharge of Malapterurus Electricus, 785
- GOULD, GEORGE M., The Katydid's Orchestra, 380; The Dogmatism of Science, 54
- Gould, Helen, Gift to the University of the City of New York, 379
- GRABFIELD, JOSEPH P., Chemical Analysis of Oils, Fats and Waxes, Dr. R. Benedikt, 138
- Graefe, Medal, Award of, 341
- GRANT, U. S., Paleontology of Missouri, Charles R. Keyes, 275
- GRAY, THOMAS, Solution and Electrolysis, W. C. D. Whetham, 670
- GREGORY, EMILY L., Untersuchungen über die Stärkekörner, Arthur Meyer, 346
- Gregory, Emily L., The Starch Grain, 742
- Griswold, L. S., Arizona Plateau, 706
- Guaycura, A Study of the, 9
- Gulf Stream, Causes of, R. MEADE BACHE, 88; JOSEPH LE CONTE, 188
- Gulliver, F. P., Tidal Sand-cusps, 705
- Gürber, K., Crystals of Serum-Albumen 785
- Guthe, K. E., and L. I. Briggs, Electrolytic Conductivity, 420
- Haak Tuke Memorial, G. F. BLANDFORD, 50
- Haddon, Alfred C., Evolution in Art, D. G. BRINTON, 900
- HALL, JR., ASAPH, Section A., Mathematics and Astronomy, A.A.A.S., 397
- HALL, G. STANLEY, Experimental Psychology in America, 735
- HALLOCK, WILLIAM, The 'Ball and Nozzle' Phenomenon, 121; Bolometric Investigations in the Infra-Red Spectrum of the Sun, 174; Double Refraction in Wood, 239; Bolometric Investigations, 344; Section B. Physics A. A. S., 349; Absorption of Terrestrial Radiations by the Atmosphere, 523; N. Y. Academy of Sciences, 564, 902; The Problem of Solar Magnetism, 589; Unpublished Papers by Holbrook Cushman, 757
- Hallock, W., Electrolytic Reproduction of Resonators, 353; Pitch of Tuning Forks, 353; Gems and Seals, 353; and R. Gordon, Color Definitions, 353
- HALSTED, BYRON D., Notes on Agriculture, 12, 68
- HALSTED, GEORGE BRUCE, Die Theorie der Parallelismen von Euclid bis auf Gauss, Paul Stäckel, 308; A Reply, 523; Pasteur as Illustration of Modern Science, 601; Eleventh International Congress Americanists, 683; The Lobachévski Prize, of 842
- Hancock, Herbert, A Text-book of Mechanics and Hydrostatics, R. S. WOODWARD, 630
- HARGITT, CHARLES W., Section Zoology of the A. A. S., 476
- Harris, E. P., A Manual of Qualitative Chemical Analysis, JAS. LEWIS HOWE, 697
- Harker, Alfred, Petrology for Students, JOSEPH P. IDDINGS, 597
- HARNLY, H. J., Volcanic Dust, 77
- Harrop and Wallis, The Forces of Nature, 736
- HARSHBERGER, JOHN W., Vergleichende Pflanzenmorphologie, E. Dennert, 311
- HARTWELL EDWARD M., On School Hygiene, 839
- Harvard University, Degrees at, 15; Quinquennial Catalogue, 47
- Hathaway, Quarternion Associative Principle, 397
- Haworth, E., Stratigraphy of Kansas Coal Measures, 777
- HAYNES, HENRY W., Shells as Implements, 593
- Hearing of School Children, 769
- Heat Standards, 519
- Health, Report of Department of, of Chicago, Arthur R. Reynolds, 54; British Institute of Public, 231; Michigan State Board of, 187
- Helium, 517, 622, and Argon, 483; H. N. STOKES, 533
- Hemholtz Memorial, 161, 408
- HENRY, CHARLES, Muscular Fatigue, 487; Oeuvres Ophtalmologiques de Thomas Young, M. Tscherning, 560
- HENSHAW, SAMUEL, Butterflies and Moths of Tennessee, Mrs. Holt White, 81; Boston Society of Natural History, 780, 902
- HERING, D. W., The Science of Mechanics, Ernst Mach, 413
- Herrick, C. L., Child Experiences, 528
- Herty, Prof. C. H., Double Salts, 355
- Herzen, A., The Isolation of a Dog's Stomach, 783

- Hibben, J. G., Sensory Stimulation by Attention, 168
Hickson, S. J., Aloyonaria, 569
High Work, What is it? L. H. BAILEY, 164
Higley, Warren, Adirondack Park, 387
Hill, E. A., Argon and Helium, 599
Hill, G. W., The Periodic Solution as a First Approximation in the Lunar Theory, 394
HILL, ROBT. T., Radiolarian Earths of Cuba, 628
Hill, Robert T., Lectures in Catholic University, 804
HINSDALE, GUY, The Practice of Massage, A. Symon Eccles, 672
His, J. W., Mechanism of Heartbeat, 784
Hitchcock, C. H. Champlain Glacial Epoch, 278; Edward Hitchcock, 383
Hodgkins Fund Prizes, 169
Hoffmann, H. O., Mining Engineering Laboratories, 394
HOLLICK, ARTHUR, Critical Periods in the History of the Earth, Joseph Le Conte, 670
Hollick, Arthur, Cretaceous Plants from Martha's Vineyard. 281; Marine Cretaceous Strata on Long Island, 400; Geological Notes, Long Island and Nantucket, 704
Hollis, Ira N., Modified Requirements for Engineering Students, 393
Hopkins' Laboratory, 103, 585
Horticulture at Cornell, L. H. BAILEY, 831
Hoskins, L. M., Graphic Methods, 392
Hotchkiss, H. J., and F. E. Millis, Galvanometer, 194
Houston, Edwin J., and A. S. Kennelly, Alternating Electric Currents, 737
HOVEY, EDMUND OTIS, Geology and Geography, A. A. S., Section E., 399
Hovey, H. C., The Isle of Shoals, 400
HOWARD, L. O., Entomological Society of Washington, 563, 703
Howard, L. O., *Anthicus baldemanni*, 635
Howarth, Sir Henry, The Glacial Nightmare and the Flood, J. W. SPENCER, 258
HOWE, JAS. LEWIS, The Springfield Meeting of the American Association for the Advancement of Science, 313; A Manual of Qualitative Chemical Analysis, E. P. Harris, 697
Hubbard, Insect Guests of Florida Tortoise, 563
Hubbard, L. L., Geological Survey of Michigan, J. F. KEMP, 108
Hubrecht, Prof., Lemurine Placentas, 573
Humphrey, A. J., Law of Fluid Pressure, 195
Hürthle K., Blood Pressure in Man, 784
Huxley, Thomas Henry, 85; Memorials 131, 267, 339, 408, 549, 768, 796; Life and Letters, 301; Biography, 621
Hyatt, Alpheus, Genus Nanno, 55
Hygiene, International Exhibition of, 132; International Congress of Railway and Marine, 341, 585; On School, EDWARD M. HARTWELL, 839
Ice Age as two Epochs, The Glacial and Champlain, View of the, WARREN UPHAM, 529
Ice Bound on Kolguev, A. Trevor-Batye, WILLIAM LIBBEY, 558
IDDINGS, JOSEPH P., Petrology for Students, Alfred Harker, 597
Index, Medicus, 45, 187; Catalogue, 376
Indiana Academy of Sciences, 848
Influence of Spray and Rain on the Form of Leaves, CONWAY MACMILLAN, 481
INGEN, GILBERT VAN, Bibliography of North American Paleontology, Charles Rollin Keyes, 701
Insect Disease, Preliminary note on a Contagious, S. A. FORBES, 375
Insects, in the U. S. National Museum, 659, and the 'Pitcher Plant,' 703
Institute of France, Centennial, 231, 585
Inverted Image on the Retina, J. MCK. C., 487; J. B. WOODWORTH, 555; JOSEPH LE CONTE, J. MCKEN CATELL, 667; CHARLES S. MINOT, 692
IRWELL, LAWRENCE, Science and Cyclopaedias, 694; Ives, F. E., Colors by Photography, 352
J., H., Astronomical, 845
J., J. F., Palaeozoic Fossils, J. E. Whiteaves, 814
Jaccard, A., Le pétrole, l'asphalte et le bitume, au point de vue géologique, S. F. PECKHAM, 237
JACSON C. L., New Color Reactions, 356; Picryl Malonic Ester, 356
Jackson and Grindley, Sodid Alcoholates, 599
Jackson, Robert T., Development of Oligoporus, 705
JACOBY, HAROLD, Astro-photographic Work at Columbia College Observatory, 724
Jacoby, Harold, The Reduction of Astro-photographic Plates, 564
Jacoby H. S., Fish Plate Timber Joints, 359
JAGGAR, JR., T. A., Geological Conference of Harvard University, 823, 858, 903
Jaggar, Jr., T. A., Pirna and Kirchberg Zones of Contact Metamorphism, 822
JAMES, JOSEPH F., Blood Examination in Disease, 412; Remarks on Recent Fungi Exsiccate, 654
James, Joseph F., Sponges, 84
JAMES, WILLIAM, Experimental Psychology in America, 626
Janet, C., Variation of Species, 571
Janssen, M., Ascent to Mt. Blanc, 585
Japanese, Why they conquered, 9; Industrial Exhibition, 340
Jewish University, 74
Johnson, J. B., A Course of Instruction in Engineering Materials, 394
Jones, H. C., The Determination of Formic Acid, 112
JOSEPHSON, ARSEL G. S., International Congress of Bibliography, 74
JUDD, CHAS. H., Philosophy in the German Universities, 126
Judd, Sylvester D., The Food of the Catbird, Brown Thrasher and House Wren, 635
Jupiter, 7
K., E. H., Bildungselemente und erziehlicher Wert des Unterrichts in der Chemie, Rudolf Arendt, 165
K., J. E., A New Method of Determining the Motion of the Stars in the Line of Sight, 475
Kaiser, K., Rhythical Contraction of Frog's Heart, 704
Kansas, Work at the University, 233; Students at the University, 664
Kastle and Keiser, Colorimetric Determination of Affinity of Acids, 28
Katydid's, Orchestra, GEORGE M. GOULD, 380; JOHN B. SMITH, S. H. SCUDDER, 591; Orchestration, ELLIOT COUES, ARTHUR E. BOSTWICK, 666
Keeler, James E., Spectrum of Saturn, 83
KEISER, E. H., Chemical Experiments, Ira Remsen and Wyatt W. Randall, 901
Kellogg, V. L., Lepidoptera, 84

- KEMP, J. F., Iowa Geological Survey Samuel, Calvin, 53; Geological Survey of Michigan, L. L. Hubbard, 108; Geological Society of America, Seventh Summer Meeting of, 277; New York Academy of Sciences, 528, 704; Fourteenth Annual Report of the U. S. Geological Survey, J. W. Powell, 632; Production of Tin in Various Parts of the World, Charles M. Rolker, 633; Geology of the Green Mountains, Raphael Pumpelly, J. E. Wolf and T. Nelson Dale, 699
- Kemp, J. F., Titaniferous Iron Ores of the Adirondacks, 281; Lead and Zinc Mines in S. W. Va., 779
- KENT, WILLIAM, The Relation of Engineering to Economics, 321
- KELVIN, LORD, MAGNUS MACLEAN and ALEXANDER GALT, Electrification and Diselectrification of Air and Other Gases, 431
- KEYES, CHARLES ROLLIN, Bibliography of North American Paleontology, 853
- Keyes, Charles Rollin, Superior Mississippian Rocks, 196; Bibliography of North American Paleontology, GILBERT VAN INGEN, 701; Paleontology of Missouri, U. S. GRANT, 275
- KNIGHT, W. C., A New Jurassic Plesiosaur from Wyoming, 449
- Korean Games, Stewart Culin, D. G. BRINTON, 776
- Kremers on Limonene, 742
- Krueger, F., Colored Stars, 384
- L., F. A., Skeletons of Zeuglodon, 42
- Labrador Peninsula, 617
- Laccolitic Mountain Groups, 228; of Colorado, Utah and Arizona, Whitman Cross, J. B. WOODWORTH, 700
- LADD, GEORGE TRUMBULL, Experimental Psychology in America, 626
- Lakes in the Australian Alps, 266
- Lambert, P. A., Continuous Functions, 396
- Landreth, O. H., Water Supply of Boston, 359
- Langley, J. N., Researches on the Sympathetic System, 783
- Latitude, Variation of, 8
- Lavoisier, Statue of, 452
- Law of the Long Run, T. C. MENDENHALL, 825
- Lawsonite, A New Rock Forming Mineral, 161
- Lazenby, W. R., Manual Training in Horticulture for Our Country Schools, 407
- Leche, W., Dental System in Mammals, 572
- LE CONTE, JOSEPH, Causes of the Gulf Stream, 188; The Nature of Vowels, 189; Are Consequences Ever a Test of Truth, 379; Inverted Image Once More, 667; Erect Vision and Single Vision, 629; A Last Word on Erect Vision, 850
- Le Conte, Joseph, Evolution, 56; Critical Periods in the History of the Earth, ARTHUR HOLLICK, 670
- Legros, R., Amphioxus, 569
- Leuckart, Rudolf, Memorial to, 187; Celebration, CH. WARDELL STILES, 523
- Leverett, Frank, New York Moraines, 26; Preglacial Valleys of Mississippi, 707
- Levier, Emile, A Traverse le Caucase, ELIZABETH G. BRITTON, 635
- Lewis, Exum Percival, Infra-Red Spectra, 83; Standard Wave-lengths, 384
- LIBBEY, WILLIAM, Ice-Bound on Kolguev, A Trevor-Battye, 558
- Library, Bureau, London, 661; Columbia College, Cornerstone Laid, 807
- Lightning, in the United States, 45; Violent Winds, Death by, 409
- Limestone, Desert in the Alps, 727
- Linnæan Society of New York, 186
- Linnæus, Contributions to a Biography of Th. M. Fries, J. A. UDDEN, 814
- Lobachévski Prize, GEORGE BRUCE HALSTED, 842
- Lobster Breeding, 341
- Lodge, Oliver J., The Second Law of Thermodynamics, R. H. T., 24
- LOEB MORRIS, Analytical Chemistry, M. Menschutkin, 189
- Lotzy, John P., Euphorbiaceæ, 312
- Lombroso Caesar and W. Ferrero, the Female Offender, CHARLES L. DANA, 164; Criminal Anthropology, 527
- Longitude, Difference between Greenwich and Madras, 482
- Longitudinal Rectification between India and Greenwich, 269
- Lowell, Percival, Mars, 133, 384
- LUCAS, F. A., Biological Society of Washington, 635, 702, 778
- Lucas, F. A., Birds of Patagonia, 703
- Ludwig, Friedrich, Lehrbuch der Biologie der Pflanzen, WM. TRELEASE, 21
- Ludwig's, Karl, Library, 102
- LUQUEER, LEA, MCI., Tables for the Determination of Common Minerals, W. O. Crosby, 738
- Lydekker, Richard, The Royal Natural History, Vol. III., C. H. M., 18
- M., A. Les aurores polaires, Alfred Angot, 107
- M., C. H., The Royal Natural History, Vol. III., Richard Lydekker, 19; North American Birds, H. Nehring, 382; On a Collection of Mammals from Arizona and Mexico, J. A. Allen, 417; List of Mammals Collected in the Black Hills Region of S. Dak., J. A. Allen, 490
- M., T. C., Metric System in England, 119; Temperature Variation of the Thermal Conductivity of Rocks, 129
- McAdie, A., The Upper Atmosphere, 131
- MCGEE, W. J., James C. Pilling, 150; Canyons of the Colorado, J. W. Powell, 593
- Mach, Ernst, The Science of Mechanics, D. W. HERING, 413
- Mackinder on English geography, 657
- MCLINTOCK, EMORY, Prof. Halsted Replied to, 453
- MACLOSKE, G., Antidromic Problems, 681
- Macloskie, G., Root Fungus of Maize, 405; Antidromy in Plants, 549
- McMahon, J., Ternery Quantics, 396
- MACMILLAN CONWAY, The Student's Text-book of Botany, Sydney H. Vines, 136; Current Problems in Plant Morphology, 183, 481
- MCMURTRE, WILLIAM, Relation of the Industries to the Advancement of Chemical Science, 283
- Magnetism, Animal, 13; Secular Variation of Terrestrial, 140
- Malaria Parasite, 270
- Mammalia, Ancestry of the, H. F. O., 14
- Manchester Museum, 623, 842
- Mann, G., Electrical Stimulation of Cerebral Cortex of Animals, 782
- MARCOU JULES, Biographical Notes on Louis Pasteur, 751
- March, Francis A., Celebration at Lafayette in Honor of, 521

- Marching, Experiments in, 484
 Marginal Plain of China, 687
 Markham, Clements R., Major James Rennell and the Rise of Modern English Geography, W. M. D., 559
 Marine, Fauna of France, 482; Laboratory of the U. S. Fish Commission at Wood's Hole, J. I. PECK, 543
 Biological Laboratory, 661; Exhibit of Schleswig-Holstein, 770; Zoological Station, Swedish, 889
 Mars, 6, 15
 Marsters, V. F., Camptonis, 55
 Martin, Artemus, Rational Plane Triangles, 395
 Mascari, A., Solar Observations Made at Catania, 384
 Maschke, Asymptotic Lines on a Circular Ring, 397
 MASON, O. T., Aboriginal Sandals, 134; Shells as Implements, 487, 693
 Mason O. T., Influence of Iron upon Native American Arts, 857
 Mason, W. P., Foreign Laboratory Notes, 354
 Massachusetts Institute of Technology, Bequests and Gifts, 163, 232, 379
 Mathematical Society, American, 161, 803; Second Summer Meeting of the, THOMAS S. FISKE, 394
 Mayan, Hieroglyphical Studies, 800; Culture, The Cradle of, 887
 Measurements of the Accuracy of Recollection, J. MCKEEN CATTELL, 761
 Medical, Record Enlarged, 72; Association, The British, 229; Antiquities, 270; Congress of Australasia, 300; Association, British, 301; Students in Italy, 378; Congress, S. African, 452; Faculty at Yale, Promotions in, 453; Schools, Students in London, 624; Association, Canadian, 624; Science, The Foundations of, LIONEL S. BEALE, 644; Congress, International, 769; Department of Vanderbilt University, 770; Club of Buenos Ayres, 848
 Medicine, French Congress of, 378; William Pepper Laboratory of Clinical, 806; The Journal of Experimental, 847
 Mediterranean Race, A New Theory about the, 726
 MENDENHALL, T. C., The Law of the Long Run, 825
 Menschutkin, M., Analytical Chemistry, MORRIS LOEB, 189
 Mentation, Science of, WESLEY MILLS, 667
 Mercer, Henry C., The Hill Caves of Yucatan, D. G. BRINTON, 900
 MERRIAM, C. HART, Generic name *Anisonyx* preoccupied, 107
 Merriam, C. Hart, American Shrews, 636
 Merriam, J. C., Reptilian Remains, 27
 MERRIMAN, MANSFIELD, A. Treaties on Civil Engineering, W. M. PATTON, 190
 Merriman, Mansfield, Drawbridge Trusses, 359, and John P. Brooks, Handbook for Surveyors, 526
 Metal Industry (ancient) in the Caucasus, 726
 Meteorological and Magnetical Observatory, Zi-ka-Wei, STANISLAS CHEVALIER, S. J., 17; Society The Royal, 72; Observatory in Tasmania, 72; Meetings, Reports of International, A. LAWRENCE RÖTCH, 336; Charts of the Red Sea, 375; Journal, American, 817
 Meteorology, at Paris, 377; in the University, CLEVELAND ABBE, 709
 Metric System in England, T. C. M., 119; in British Pharmacopœia, 269; in Mexico, 339; in Great Britain, 802
 Mexican Highways, Ancient, 888
 Meyer, Arthur, Untersuchungen über die Stärkekörner EMILY L. GREGORY, 346
 Meyrick, Edward, Handbook of British Lepidoptera, S. H. SCUDDER, 854
 Miall, L. C., The Natural History of Aquatic Insects, S. H. S., 81
 Microscopical Society, The American, 160, 297
 Michelson, A. A., Telescope, 83
 MILES, MANLY, The Perception of Direction, 808
 MILL, ROBERT HUGH, Geography at the British Association, 545
 Miller, A. S., Ferrous Chloride, 600
 MILLER, J. GERRIT S., Winge on Brazilian Apes, 812
 Millikan, R. A., Polarization of Light, 419, 816
 MILLS, WESLEY, The Nature of Vowels, 303; The Science of Mentation, 667
 Minerals, Resources of the United States, 376
 MINOT, CHARLES S., Allgemeine Physiologie, Max Verworn, 557; An Atlas of the Fertilization and Karyokinesis of the Ovum, Edmund B. Wilson, 695; Inverted Image on the Retina, 692
 Minot, Charles S., Rejuvenation and Heredity, 405
 Minnesota, University, degrees in the, 164; Buildings, 520, 664
 Missouri, University Buildings, 47
 Moale, P. R., Naphthalene, 856
 Mohler, J. F.; and W. J. Humphries, Certain Properties of Line Spectra, 353
 MOLENBROEK, P. and S. KIMURA, To Those Interested in Quaternions and Allied Systems of Mathematics, 524
 Molusca, Geographical Distribution of, FRANK C. BAKER, 179
 Monist, 56, 527
 Mont Blanc Observatory, 407
 Montgomery, T. H., Hermaphroditism, 84
 Moore, E. H., Jordan's Linear Substitution Groups, 396
 MOORE, E. L., Relations of the Weather Bureau to the Science and Industry of the Country, 576
 MOORE, J. W., Electricity Up to Date for Light, Power and Traction, John B. Verity, 192
 Moore, L. T., Iron Wire and Magnetization, 817
 Moors of Northwest Germany, 885
 Moraines, 26
 Moraine Amphitheater of Ivrea, 727
 Moorehead, J. T., Calcium Carbide, 358
 Morgan, C. Lloyd, Naturalism, 527
 MORGAN, T. H., An Introduction to General Biology, Sedgwick and Wilson, 740
 Morgan, T. H., Annelids,
 Morley, E. W., and William A. Rogers, Expansion of Jessop's Steel, 351
 Morley, E. W., Volumetric Composition of Water, 355
 MORSELL, W. F., National Geographic Society, 743, 820
 Mortality in New York State, 47
 MOSES, A. J., A Treatise on the Morphology of Crystals, N. Story-Maskelyne, 82
 Motorcycle Contest, 890
 Mottier, David M., Embryology of Ranunculaceæ, 167
 Mountain Climbers and the Perception of Distance, HIRAM M. STANLEY, 851
 Mountains and Lowlands of Greece, 658
 Muckey, F. S., and W. Hallock, Voice Production, Voice Analysis, 352
 Munich, Enlargement of the University, 692

- Murray, George, An Introduction to the Study of Seaweeds, W. A. SETCHELL, 775
- Murray, John, Deep-sea Explorations, 575
- Muscular Fatigue, CHARLES HENRY, 478
- Museum, at Toronto, 690; at Sydney, Australia, 890
- Museums, The Relationships and Responsibilities of, G. BROWN GOODE, 197
- Nardroff, E. R., Apparatus for Studying Color Phenomena, 352
- National Academy of Sciences, 637
- Native Plums and Russian Cherries, 68
- Naturalist, American, 84; In Mexico, WITMER STONE, 592
- Naturalists, American Society of, 847
- Naturforscher und Aerzte, Versammlung deutscher, 230
- Navigation in Spain, History of, JOSEPH DE PERROTT, 63
- Nebulae, 7
- Nehrling, H., North American Birds, C. H. M., 382
- Neurology, Journal of Comparative, 528
- Newbold, W. R., Experimental Induction of Automatic Processes, 168
- New Books, 28, 56, 84, 112, 168, 196, 276, 312, 384, 420, 456, 492, 564, 600, 636, 672, 708, 780, 824, 860, 904
- NEWELL, F. H., American Forestry Association, 385
- Newell, F. H., Hydrographic Work, 743
- 'New Race' in Egyptian History, D. G. BRINTON, 227
- New York Academy of Sciences, J. F. KEMP, 528, 704, 779; WM. HALLOCK, 564, 902; BASHFORD DEAN, 742
- Nicolar, Joseph, Life and Traditions of the Red Man, A. S. G., 310
- Nipher, Francis A., Electricity and Magnetism, ARTHUR G. WEBSTER, 809
- Nomenclature, International Code of, CH. WARDELL STILES, 665
- Northwestern Tribes of Canada, Franz Boas, ALEX. F. CHAMBERLAIN, 668
- Norton, T. H., Thioacetic Acid, 356
- Notes from London, R. H. T., 157
- Noyes and Ellis, Diphenylbiphenyl, 600
- NOYES, WILLIAM A., A. H. GILL and FRANCIS C. PHILLIPS, Section C, Chemistry A. A. A. S., 354
- Noyes, W. A., Camphoric Acid, 355
- Numismatic Society of London, 72
- O., H. F., Ancestry of the Mammalia, 14; Recent Investigations of the Embryology and Pathology of the Teeth, 686
- Observatory, New, 8; Yerkes, 68; Flower, of the University of Pennsylvania, 451; at Cornell University, 625; of Harvard College, 658; on Mt. Mounier, 689; Students, at Minnesota, 733; Harvard College, 888
- OGDEN, HENRY N., Economics of Engineering Public Works, 539
- Oliver, F. W., The Natural History of Plants, ELIZABETH G. BRITTON, 634
- Origin of the Valleys of the Rhone, 688
- Orndorff and Cameron on Dianthaceae, 741
- Ornithologists' Union, American, 585; JOHN H. SAGE, 785
- OSBORN HENRY F., Vertebrate Paleontology in the American Museum, 178
- Osborne, T. B., Vegetable Proteids, 356
- Otology, International Congress of, 187, 550
- Oxford University, Research Degrees, 48; Anthropology, 48; University Extension, 48; Lectures at, 588
- Oysters and Typhoid, R. W. BOYCE and W. A. HERDMAN, 460, 691; The Culture of Edible, 891
- PACKARD, A. S., Charles Valentine Riley, 745
- Paleontology, of Missouri, Charles R. Keyes, U. S. GRANT, 275, Bibliography of North American, Charles Rollin Keyes, GILBERT VAN INGEN, 701
- PALMER, T. S., The Earliest name for Steller's Sea Cow and the Dugong, 449
- Palmer, J. A. de Forest, D₃ Helium Line in Solar Spectrum, 599
- Parallax of Eta Cassiopeia, 100
- Parinaud, La Sensibilité de l'œil aux couleurs spectrales, E. C. SANFORD, 418, 698
- Paris Academy, 104, 131, 269; Streets, Names of, 104
- Park System, A Proposed County, 130
- Parker, E. W., Production of Coal in 1894, 622
- Pasteur, Louis, II. W. CONN, 601; as Illustration of Modern Science, GEORGE BRUCE HALSTED, 611; 'Institut,' 620; Biographical notes on, JULES MARCOU, 751; Memorial to, 689, 768, 804; His Will, 804
- Patents in United States, 270; New Rule for, 484
- Patton, W. M., A Treatise of Civil Engineering, MANSFIELD MERRIMAN, 190
- Pearson, D. K., Gift to Mt. Holyoke College, 626
- Peary Relief Expedition, 339
- PECK, J. I., Marine Laboratory of the U. S. Fish Commission at Wood's Hole, 543
- PECKHAM, S. F., Le pétrole l'asphalte et le bitume. A. Jacard, 237
- Peckham, S. F., Pitch Lake of Trinidad, 26
- Pennsylvania, University of, Appropriations for, 73; Economic Museum, 133; Gifts to, 104, 134, 692
- PENFIELD, S. L., Minerals and How to Study Them, E. S. Dana, 774
- Penfield, S. L., and J. H. Pratt, Minerals of the Triphylite-lithiophilite Group, 399
- Perception of Direction, MANLY MILES, 808
- Periodic Law, How Far Shall it be Followed in Teaching Chemistry? F. P. VENABLE, 506
- Perrine Comet, 804
- PERROTT, JOSEPH DE, History of Navigation in Spain, 63
- Philological Association, American, 102
- Philosophical Society, American, Elections, 804
- Philosophy in the German Universities, CHARLES H. JUDD, 126
- Phototopography, J. A. FLEMER, 152
- Phylogeny, The Question of Pteridophyta, 183
- Physical, Chemistry, The Major Premise in, ROBERT B. WARDER, 651; Review, 193, 419, 816; Features of Mauritius, 887
- Physics, 129; The Principles of, Alfred P. Gage, W. LE CONTE STEVENS, 306; Building at Kansas University, 806
- Physiographic Notes from Iceland, 885
- Physiography, Current Notes on, W. M. DAVIS, 10, 39, 97, 228, 266, 373, 514, 617, 657, 687, 727, 767, 885
- Physiological and Clinical Research, The Relations of, 268; Congress, Berne, 781, 880; Society, American, 803
- Physiologists, The Congress of, 68
- Physiology in 1894, 95; International Congress of, 419
- Pickering, E. C., Stellar Photometer, 383
- Pictographs of Lower California, 67

- Pignuts, WILLIAM TRELEASE, 136
Pierce, B. O., and R. W. Wilson, Temperature Variation of Thermal Conductivities of Marble and Slate, 777
Pilling, James C., W J MCGEE, 150
Pillsbury, J. H., On Standard Colors, 353; Color Terms, 353
Pilsbry, Henry A., Marine Mollusks of Japan, W. H. DALL, 855
Pinchot, Gifford, The Present Condition of Natural Forests, 389
Pineapple Culture, 68
Pithecanthropus erectus, 130, 290, 945
Plant Morphology, Current Problems in CONWAY MACMILLAN, 183, 481
Plants, in the Canary Islands, 14; The Natural History of, F. W. Oliver, ELIZABETH G. BRITTON, 634; Of the Alpine Regions, 767
Plesiosaur from Wyoming, A New Jurassic, W. C. KNIGHT, 449
Polar Expedition, M. Andr e's, 43
POOR, CHAS. LANE, Scientific Association of Johns Hopkins University, 822
Population of France, 102; and England, 849
PORTER, W. T., A Text Book of Physiology, M. Foster, 381
Powell, J. W., Canyons of the Colorado, W J MCGEE, 533
Powell, J. W., Fourteenth Annual Report of the U. S. Geological Survey, J. F. KEMP, 632
Prescott, A. B., Inherent Limitations in the Accuracy of Analytical Work, 356
Preyer, W., Zur Psychologie des Schreibens, PERSIFOR FRAZER, 78
Princeton Preparatory School, 163
Priority, The 'Date of Publication' in the Light of the Law of, HERBERT HAVILAND FIELD, 303
Prizes of the Danish Academy of Sciences, 452; of the Soci t  de M dicine Publique, etc., 452
Processes of Life Revealed by the Microscope, SIMON HENRY GAGE, 209
Prof. Halsted Replied to, EMORY MCCLINTOCK, 453
Progressive Depopulation of the Northern Regions, 66
Prosser, C. S., Rocks of Central Kansas, 708
Protoplasm, The Structure of, E. A. ANDREWS, 893
Provisional Functions of Government, with Special Reference to Natural Resources, B. E. FERNOW, 252
Psyche, 168, 312, 456, 600, 778
Psychological Notes, J. McK. C., 13, 99; Review, 168, 818; Association, American, 803
Psychology, Journal of, 300; Experimental, in America, WILLIAM JAMES, 626; GEORGE TRUMBULL LADD, 626; J. MARK BALDWIN, 627; J. MCKEEN CATTELL, 627; G. STANLEY HALL, 735; The Third International Congress of, 660; Laboratory at Kansas University, 692
Pumpelly, Raphael, J. E. Wolff and T. Nelson Dale, Geology of the Green Mountains, J. F. KEMP, 699
PUTN, M. I., Tendencies of Modern Electrical Research, 861
Pupin, M. I., Flow of Alternating Currents in Electric Cable, 351; Relation between Electro-magnetic Force and Their Displacements, 352
PUTNAM, F. W., The History, Aims and Importance of the A. A. S., 171
Pynchon, W. H. C., Great Falls of the Mohawk, 401
Quaternions, and Allied Systems of Mathematics to those Interested in, P. MOLENBROEK and S. KIMURA, 534; VICTOR C. ALDERSON, 735
Quereau, E. C., Cliffs and Exotic Blocks of N. Switzerland, 707
Racial and Ethnic Traits, 66
Radiolarian Earths of Cuba, ROBT. T. HILL, 628
Railway Speed in Great Britain, R. H. T., 338, and America, 408
RAMSAY, A., Bibliography of Scientific Literature, 48
Randolf, Prof. L. S., Economic Element in Technical Education, 393
Rault, Prof., Awarded Biennial Prize of French Institute, 550
Rawitz, Bernhard, Leitfaden f r Historiologische Untersuchungen, S. H. GAGE, 455
Raymond, William G., Scope of an Engineering School, 391
Reber, Louis E., Requirements of Engineering Colleges in Non-professional Studies, 392
Red Man, Life and Traditions of the, Joseph Nicolai, A. S. G., 310
REES, J. K., Notes on the Progress of Astronomy During the Year 1894, 5
Rehmke, Johannes, Lehrbuch der allgemeinen Psychologie, A. C. ARMSTRONG, JR., 275
Relations of the Weather Bureau to the Science and Industry of the Country, E. L. MOORE, 576
Rensen Ira and Wyatt W. Randall, Chemical Experiments, E. H. KEISER, 901
Reply, A, GEORGE BRUCE HALSTED, 523; FRANK C. BAKER, 693
Reynolds, Arthur R., Report of Department of Health of Chicago, 54
Richards, Ellen H. and J. W. Elms, Coloring Matter of Natural Water, 354
Rifle, New Magazine, 689
Riley, C. V., Social Insects, 71
Riley, Charles Valentine, A. S. PACKARD, 745
Rimington, E. C., Alternating Currents, 419
River Valleys of the Himalayas, 688
Rivers of Spain, 619
Roberts, R. A., Systems of Conics, 396
Robinson, B. L., Nomenclature Question, 312
Rockfeller, John D., Gift to Chicago University, 664
Rock Fissure, G. K. GILBERT, 117
Rogers, W. A., Heat, 353; Molecular Structures of Bronze, Glass and Steel, 354; Relative Length of Yard and Metre, 354
Rolkner, Charles M., The Production of Tin in Various Parts of the World, J. F. KEMP, 633
Ross, Leonard W., Sea Coast Planting, 389
ROTCH, A. LAWRENCE, Reports of International Meteorological Meetings, 336
Rowland, H. A., Solar Spectrum Wave Lengths, 83
Royal Society of New South Wales, 338; Institution Gifts to, 732; Society Anniversary Meeting, 846; Deaths in, 890; Election of Officers, 891
Royce, Josiah, Anomalies of Self-consciousness, 818
Run-off of Rivers, 229
RUSBY, H. H., Torrey Botanical Club, 742, 903
Rusby, H. H., Poisonous Plants, 903
Russell, I. C., Debris and the Flow of Glaciers, 708
RUSSELL, H. L., Typhoid Fever Disseminated through the Milk Supply, 682
Russell, H. L., Leaf Rot of Cabbage, 402
Russell's Lakes of North America, 514
Russian Thistle, Some Plants That Look Like the, 12

- Ryder, John Adam, HARRISON ALLEN, 334
- S., S. H., The Natural History of Aquatic Insects, L. C. Miall, 81
- Sable Island, 886
- SAGE, JOHN H., American Ornithologists' Union, 785
- St. Elias, Bear, W. H. DALL, 87
- St. Louis Academy of Science, A. W. DOUGLAS, 26, 636, 707, 744, 859
- St. Luke's Hospital, N. Y., 623
- ROLLIN D. SALISBURY, The Arctic Expedition of 1895 and Lieutenant Peary's Work, 457
- Salix Wardi, Bebb, N. M. GLATFELTER, 582
- Salisbury, R. D., Preglacial Gravels
- Sandals, Aboriginal, O. T. MASON, 134; 377
- SANFORD, E. C., La sensibilité de l'œil aux couleurs spectrales, M. Parinaud, 418, 698
- Sanford, Fernando, Electrical Conductivity of Metallic Wires, 816
- Sanitary, Engineers, Bi-monthly Journal, 46
- Saporta and Williamson and their Work in Paleobotany, LESTER F. WARD, 141
- SCHUCHERT, CHARLES, Dry Dredging in the Mississippi Sea, 679; American Fossil Brachiopoda, 723.
- Science, The American Journal of, 26, 139, 599, 777; and Cyclopædias, LAWRENCE IRWELL, 694; or Poetry, W. K. BROOKS, 437; S. H. GAGE, 590; Progress, 46
- Scientific Notes and News, 14, 43, 68, 100, 130, 158, 184, 229, 267, 299, 338, 376, 407, 449, 482, 516, 547, 584, 619, 658, 689, 728, 768, 801, 845, 888; Societies of Great Britain, Year-book of, 14; Literature 18, 51, 78, 107, 136, 164, 189, 237, 272, 306, 344, 381, 413, 454, 487, 525, 557, 593, 630, 668, 695, 736, 773, 809, 854, 893; Journals, 26, 55, 83, 111, 139, 167, 193, 310, 383, 419, 456, 491, 527, 599, 707, 741, 777, 816, 860; Societies, Winter Meetings of, 728; Societies, Letter of the Philadelphia Local Committee, 801; Societies of Washington, 804; Association of Johns Hopkins University, CHAS. LANE POOR, 822
- Scott, E. B., Tertiary Lakes of North America, 570
- SCRIBNER, F. LAMSON, Agronomy in the Department of Agriculture, 151
- SCUDDER S. H., The Katydid's Orchestra, 591; Handbook of British Lepidoptera, Edward Meyrick, 854
- Sedgwick and Wilson, An Introduction to General Biology, T. H. MORGAN, 740
- Seeborn, Henry, Work of, 849
- Seiche in Lake Superior, 514
- Seismological Station, 377
- Semon, Prof., Fetal Membranes of Vertebrates, 572
- Serpents, Blood Serum of Venomous, 71
- Serum Treatment of Diphtheria, 301
- SETCHELL, W. A., An Introduction to the Study of Seaweeds, George Murray, 775
- Shaler, N. S., Effects of Expulsion of Gases from Interior of the Earth, 281; Causes of Imperfection of Geological Record, 858
- Shaw, J. B., The Linear Vector Operator of Quaternions, Application of Quaternions to Geometry, 395; Useful Quaternion Expressions, 396
- Shells as Implements, O. T. MASON, 487, 693; HENRY W. HAYNES, 593
- Sherrington, C., Experiments on Posterior Nerve Roots of Monkeys, 785
- Skinner, A. N., Zone Work at University of Washington, 399
- Slade, D. D., Significance of the Jugal Arch, 299
- SLOSSON, E. E., An Easy Method of making Line Drawings, 893
- Small, John Kunkel, North American Species of the Genus Polygonum, WM. TRELEASE, 21
- Smith, Donaldson, Return of, 849
- SMITH, EUGENE A., The Geological and Natural History Survey of Minnesota, N. H. Winchell, 92; Alabama Industrial and Scientific Society, 25, 859; Correction, 107
- Smith, E. E., A Specific Form of Cell Metabolism, 357
- Smith, Erwin F., Wilt Diseases, 403; Southern Tomato Blight, 405
- SMITH, JOHN B., The Katydid's Orchestra, 591
- Smith, John Donnell, Undescribed Plants from Guatemala, 167
- Smithsonian Exhibit at Atlanta, 547
- Snakes in Oregon, 730
- Social Science Association, 301
- Societies and Academies, 25, 110, 528, 563, 635, 702, 742, 778, 820, 856, 902
- Sociology, American Journal of, 188
- Solar Parallax, 6; Radiation, Temperature of Sun, 83; Magnetic Problem, The Status of the, FRANK H. BIGELOW, 509; Magnetism, The Problem of, WILLIAM HALLOCK, 589
- Some Notes on Darlington (S. C.) 'Bays,' L. C. GLEN, 472
- Spangler, H. W., Mechanical Engineering, 394
- Spectrum Top, 13
- SPENCER, J. W., The Glacial Nightmare and the Flood, Sir Henry Howarth, 238
- Spencer, J. W., Geological Canals between Atlantic and Pacific Ocean, Recent Elevation of New England, 400
- Squashes, Artificial Pollination of, 12
- Stäckel, Paul, Die Theorie der Parallellinien von Euclid bis auf Gauss, GEORGE BRUCE HALSTED, 308
- Standard Natural History, Decision against Estee and Lauriat, 548
- Stanford University, Decision in Favor of, 47, 551
- STANLEY, HIRAM M., Mountain Climbers and the Perception of Distance, 851
- Stärkekörper, Untersuchung über die, Arthur Meyer, EMILY L. GREGORY, 346
- Stars in the Line of Sight, A New Method of Determining the Motion of the, J. E. K., 475
- Statistical Institute, International, 71
- Statistical Society, Royal, 72
- STEJNEGER, LEONHARD, Aleut Baidarkas in Kamchatka, 62
- Stejneger, Leonhard, Investigation of Seals, 46; Explorations of, 661
- Stellar's Sea Cow and the Dugong, The Earliest Name for, T. S. PALMER, 449
- Stereo-photo microscope, 732
- Stereoskopische Bilder, 769
- STETSON, GEORGE R., Anthropological Society of Washington, 857
- STEVENS, W. LE CONTE, The Principles of Physics, Alfred P. Gage, 306
- Stevens, W. Le Conte, Recent Progress in Optics, 349, 599; Limits of Range of the Human Voice, 352
- Stevenson, J. J., Geological Notes on Indian Territory, 779

- STILES, CH. WARDELL, The Rudolf Leuckart Celebration, 523; International Code of Nomenclature, 665
- STOKES, H. N., Helium and Argon, 533
- Stone Industry in 1894, 661
- STONE, WITMER, The Naturalist, in Mexico, 592
- Story-Maskelyne, N., A Treatise on the Morphology of Crystals, A. J. MOSES, 82
- Strong, C. A., Psychology of Pain, 168
- Students, American, at German Universities, 163; Swiss Universities, 410; Number of at Harvard, 453; Williams, 653; Boston, 453; Penna., 485, 521; Yale, 520; Brown, 520; Minnesota, 551; Texas, 552
- Submergence of Western Europe Prior to the Neolithic Period, AGNES CRANE, 2
- Suicide, Frequency of, in Russia, 132
- Summer Congress at Greenacres, 71
- Sun, The, DAVID P. TODD, 29; Total Eclipse of 1896, 408
- Suppression of Discussion, Alleged, J. McKEEN CATTELL, 411
- Surgical Polyclinic in Berlin, 807
- Swingle, W. T., Fungus Gardens in the Nest of an Ant, 404
- Swiss Landslide in the Glacial Period, 618
- Sydney University, Bequest to, 340
- Syphilis and Leprosy in Ancient America, 265
- T., R. H., The Second Law of Thermodynamics, Oliver J. Lodge, 24; Notes from London, 157; Railway Speed in Great Britain, 338
- Taber, H., Bilinear Forms, 397
- Tacchini, P., Distribution in Latitude of Solar Phenomena, 83
- Tactical Perception and Natural Selection, Mr. Spencer on, J. McKEEN CATTELL, 852
- Talbot, Eugene A., The Etiology of Osseous Deformities, CHARLES S. DANA, 239
- Teay Valley, West Virginia, 40
- Teeth, Recent Investigations of the Embryology and Pathology of, H. F. O., 686
- Telescope, Bruce Photographic, 804
- Temperature Variation of the Thermal Conductivity of Rocks, T. C. M., 129
- Terrestrial Magnetism, Report of Committee, 518
- Testimony versus Evidence, W. K. BROOKS, 771
- Thermal Conductivity of Copper, 193
- Thermodynamics, The Second Law of, Oliver J. Lodge, R. H. T., 24
- Thermophone, GEORGE CHANDLER WHIPPLE, 639
- Thompson, Edward Maunde, member of Berlin Academy of Science, 72
- Thomson, J. J., Elements of the Mathematical Theory of Electricity and Magnetism, ARTHUR G. WEBSTER, 809
- THURSTON, R. H., Notes on Engineering, 292
- Tidal Streams about the British Isles, 375
- Tigerstedt, R., Respiratory Gaseous Exchange, 783
- Tin, The Production of, in Various Parts of the World, Charles M. Rolker, J. F. KEMP, 633
- Torrey Botanical Club, H. H. RUSBY, 742, 903
- Top for Educational Purposes, 340
- Topinard, P., Man as an Animal, 527
- Topographic Methods, J. A. FLEMER, 15
- Topographical Maps, 98; Index of Names on, 622
- Todd, J. E., Geological Work in South Dakota, 383
- TODD, DAVID P., The Sun, 29
- Tracy, Roger S., Sanitary Information for Householders, 55
- Transverse Valleys in the Southern Alps, 617
- TRELEASE, WM., Biologie der Pflanzen, Friedrich Ludwig, 21; The Pignuts, 136
- Trephining, Prehistoric, in Russia, 727
- Trevor-Batye, A., Ice-bound on Kolguev, WILLIAM LIBBEY, 558
- Trinity College, Dublin, Examinations for Women, 254
- Trowbridge, J., and W. Duane, Velocity of Electric Waves, 140
- True, Rodney H., Effect of Turgor and Temperature on Growth, 403
- Tuomey, J. W., Genus *Opuntia*, 312
- Tscherning, M., Oeuvres ophtalmologiques de Thomas Young, CHARLES HENRY, 560
- Typhoid Fever Disseminated through the Milk Supply, H. L. RUSSELL, 682
- UDDEN, J. A., Contributions to a Biography of Linnaeus, Th. M. Fries, 814
- Uline, Edwin B., and William L. Bray, North American *Amaranthaceae*, 312
- Union College Centennial, 15, 73
- Université Nouvelle, 850
- University and Educational News, 15, 47, 72, 104, 133, 163, 223, 301, 378, 409, 453, 484, 520, 551, 586, 625, 664, 691, 732, 770, 806, 849, 892
- University of the City of New York, 133, 520; College, S. Wales, Grant to, 588; Extension Bulletin, 808; Extension in Vienna, 850
- UPHAM, WARREN, View of the Ice Age as Two Epochs, the Glacial and Champlain, 529
- Upham, Warren, The Ice Age as Two Epochs, 401
- Vaccination, Hundredth Anniversary Celebration, 270; Priority in Discovery of, 341
- Valleys in the Plateau of the Ardennes, 618
- Van Hise, C. R., Analysis of Folds, 250; Primary and Secondary Structures in Rocks, 398
- Van Vleck, E. B., Study of Related Differential Equations, 396
- Veeder, M. H., Sun Spots and Magnetic Storms, 399
- VENABLE, F. P., How Far Shall the Periodic Law be Followed in Teaching Chemistry? 506
- Venable, F. P., Periodic System, 355
- Verity, John B., Electricity Up to Date for Light, Power and Traction, J. W. MOORE, 192
- Vermeule, Cornelius C., Forests and Rivers of New Jersey, 387
- Vermont University, Dormitory, 47; Gifts to, 588
- Vertebrate Paleontology in the American Museum, HENRY F. OSBORN, 178
- Vervorn, Max, Allgemeine Physiologie, CHARLES S. MONOT, 557
- Vines, Sidney H., The Students' Text-book of Botany, CONWAY MACMILLAN, 136
- Virginia University, Library Destroyed, 625, 732
- Vision, Erect and Single Vision, JOSEPH LE CONTE, 629; Last Word on Erect, JOSEPH LE CONTE, 850
- Vital Statistics of New England, 230
- Vitzu, N., Removal of Occipital Lobes in Dog's Brain, 782
- Vogt, Carl, Statue of, 187
- Volcanic Dust, H. J. HARNLY, 77
- Völkerkunde, Veröffentlichungen aus dem königlichen Museum für, D. G. BRINTON,
- Vowels, The Nature of, JOSEPH LE CONTE, 189; WESLEY MILLS, 303

- Wadsworth, M. E., Electric System Applied to Courses in Mining, 392; Elective System in Michigan Mining School, 492
- Wainwright, J. H., Vegetable and Animal Fats, 857
- Walker, Joseph B., Forest of New Hampshire, 386
- Ward, Julius H., White Mountain Forests, 386
- WARD, LESTER F., Saporta and Williamson and their Work in Paleobotany, 141
- Ward, Robert de C., Meteorology as a University Course, 817
- WARDEE, ROBT. B., The Major Premise in Physical Chemistry, 651
- WATTS, W. W., Geology at the British Association, 493
- Weather, Service State Convention, 186; Report of N. C. Experimental Station, 378; Review, the Monthly, 408; Forecasts, 891
- Webber, H. J., Pollinating and Hybridizing Citrus Fruits, 406
- WEBSTER, ARTHUR G., Elements of the Mathematical Theory of Electricity and Magnetism, J. J. Thompson; Electricity and Magnetism, Francis A. Nipher, 809
- Weed, W. H. and L. U. Pirsson, Igneous Rocks, 777
- WEEKS, F. B., A Card Catalogue of Scientific Literature, 75
- Weights and Measures, Standard Russian, 186
- WELKER, P. A., Electric Storms on Mount Elbert, Col., 305
- Wheeler on Benzimidomethyl Ether, 28
- Whetham, W. C. D., Solution and Electrolysis, THOMAS GRAY, 670
- WHIPPLE, GEORGE CHANDLER, Thermophone, 639; A Simple Apparatus for Collecting Samples of Water and Various Depths, 841
- White, Mrs. Holt, Butterflies and Moths of Teneriffe, SAMUEL HENSHAW, 81
- White and Jones, Sulphonphthaleins, 599
- Whiteaves, J. E., Palæozoic Fossils, J. F. J., 814
- Whitman College, Dr. Pearson's Gift to, 47
- Whitman, Frank P., Flicker Photometer, 353
- Wiedersheim, R., The Structure of Man, HARRISON ALLEN, 899
- Wild, Prof. H., Resignation, 105
- Wilder, Burt G., Cerebral Fissures of Two Philosophers, 528
- WILEY, H. W., Agricultural Chemistry, 442
- Wiley, H. W., Record of Progress in Agricultural Chemistry, 357
- Williamson and Saporta and their Work in Paleobotany, LESTER F. WARD, 141
- Wilson, A. G., Upper Silurian, 401
- Wilson, Edmund B., An Atlas of the Fertilization and Karyokinesis of the Ovum, CHARLES S. MINOT, 695
- Winchell, N. H., The Geological and Natural History Survey of Minnesota, EUGENE A. SMITH, 22; Geology of the Lake Superior Region, 55, 491, 860
- Winchell, N. H., The Keweenaw, 196, 383
- Winds and Ocean Currents, W. M. DAVIS, 342
- Winge on Brazilian Apes, GERRIT S. MILLER, JR., 812
- Wood, DeVolson, Mathematical Theory of the Windmill, 359
- WOODMAN, DURAND, Chemical Society (N. Y.), 779, 856
- Woodpeckers, Food of, 45
- Woods, Albert F., Transpiration of Plants, 403
- WOODWARD, R. S., A Text-book of Mechanics and Hydrostatics, Robert Hancock, 630; Mechanics (Dynamics), R. T. Glazebrook, 631
- Woodward, R. S., Results of Experiments on Metallic Spheres Falling in Water, 564; Systems of Mechanical Units, 704
- Wolves in France, Extinction of, 342
- WOODWORTH, J. B., The Inverted Image on the Retina Again, 555; The Laccolitic Mountain Groups of Colorado, Utah and Arizona, Whitman Cross, 700; Fauna Fossil de la Sierra de Catorce, en San Luis Potosi, Aguilera y Del Castillo, 739
- WOODWORTH, J. B., Great Barrier Reef of Australia, 743; Some Features of Joints, 903
- WOODWORTH, W. MCM., and FRANK SMITH, A Monograph of the Order Oligochaeta, Frank Evers Beddard, 696
- WRIGHT, G. F., Glacial Phenomena between Lake Champlain, Lake George and Hudson River, 673
- Yucatan, Hill Caves of, Henry C. Mercer, D. G. BRINTON, 900
- Yucatecan Studies, 766
- Zenglodon, Skeletons of, F. A. L., 42
- Zograf, Prof., Lacustrine Fauna of European Russia, 568; Teeth of the Chronostean Ganoids, 573
- Zoological Notes, 41; Congress, Third International, 565
- Zoologists' Directory, International, 450
- Zoology, A New Bibliographical Bureau for, HERBERT HAVILAND FIELD, 234; Section of the A. A. S., CHARLES W. HARGITT, 476; International Congress of, 482; Inaccurate, THEO. D. A. COCKE-ERELL, 556

ERRATA:—p. 79, col. 1, line 17: for arc read is. p. 382, col. 2, line 42: for *Leucoatiete* read *Leucosticte*. p. 382, col. 2, line 49: for Tomhel read Towhee. p. 384, col. 2, line 33: for Colonia read Catania. p. 492, line 13: for *Braceiocrinus* read *Brachiocrinus*. p. 701, col. 1, line 47: for Vodges read Vogdes. p. 701, col. 2, line 25: for Skunnemunk read Shunnemunk.

SCIENCE

NEW SERIES.
VOL. II. No. 27.

FRIDAY, JULY 5, 1895.

SINGLE COPIES, 15 CTS.
ANNUAL SUBSCRIPTION, \$5.00.

GUSTAV E. STECHERT'S

Recent Importation of Scientific Books.

BEBBER, DR. W. J. von. Hygienische Meteorologie. Für Aerzte und Naturforscher. Mit 42 in den Text gedruckten Abbildungen. 8°. M. 8.

BERGH, DR. R. S. Vorlesungen über allgemeine Embryologie. Mit 126 Figuren im Text. 289 Seiten. Gross 8°. M. 7.

DAMMER, DR. O. Handbuch der chemischen Technologie. Unter Mitwirkung von Th. Beckert, Dr. Bender, Dr. Benedict, Dr. Börnstein, u. A. Band I. Mit 191 in den Text gedruckten Figuren. gr. 8°. M. 24.

HANDWÖRTERBUCH DER ASTRONOMIE, Unter Mitwirkung mehrerer Professoren, herausgegeben von Prof. Dr. W. Valentiner. Mit Abbildungen. Lieferung 1. 128 Seiten. Gross 8°. M. 3.60.

HARTLEBEN'S statistische Tabelle über alle Staaten der Erde. Uebersichtliche Zusammenstellung von Regierungsform, Staatsoberhaupt, Thronfolger, Flächeninhalt, absoluter und relativer Bevölkerung, Staatsfinanzen, Handelsflotte, Handel, Eisenbahnen, Telegraphen, Zahl der Postämter, Werth der Landesmünzen in deutschen Reichsmark, Gewichten, Längen und Flächenmassen, Hohlmassen, Armee, etc. M. 50 Pf.

VON JONSTORFF, HANNS FREIHERR JÜPTNER. Fortschritte im Eisenhütten-Laboratorium in den letzten 10 Jahren. Erster Band. Mit 99 Figuren. 270 Seiten. 8°. M. 8.50.

KOLBE, BRUNO. Einführung in die Electricitätslehre. Band II. Dynamische Electricität. Mit 75 in den Text gedruckten Holzschnitten. 187 Seiten. 8°. M. 3.

KRÄMER, INGENIEUR JOS. Wirkungsgrade und Kosten elektrischer und mechanischer Kraft-Transmissionen. Mit vielen Figuren, Schemas und einer Tafel. 88 Seiten. 8°. M. 3.

LELUC, A. Manipulations de Physique Avec 144 figures intercalées dans le texte. 392 pages. 8°. Fr. 6.

MEISSNER, G. Die Hydraulik und die hydraulischen Motoren. Ein Handbuch für Ingenieure, Fabrikanten und Constructeure. Zum Gebrauche für technische Lehranstalten sowie ganz besonders zum Selbstunterricht. Zweite vollständig neu bearbeitete Auflage von Dr. H. Hederich und Ingenieur Nowak. I. Band. Die Hydraulik. Lieferung 1. 80 Seiten. 8°. M. 3.

MEYER, PROF. DR. ARTHUR. Untersuchungen über die Stärkekörner. Wesen und Lebensgeschichte der Stärkekörner der höheren Pflanzen. Mit 9 Tafeln und 99 in den Text gedruckten Abbildungen. 320 Seiten. Gross 8°. M. 20.

METZGER, PROF. DR. A., und PROF. DR. N. I. C. MÜLLER, Die Nonnenraupe und ihre Bakterien Untersuchungen ausgeführt in den zoologischen und botanischen Instituten der Königl. preuss. Forstakademie Münden. Mit 45 of Tafeln in Farbendruck-160 Seiten. 8°. M. 16.

MICHAUT, L. ET M. GILLET. Leçons élémentaires de télégraphie électrique. Système Morse-Manipulation-Notions de Physique et de Chimie-Piles-Appareils et accessoires installation des postes. 2^e édition, entièrement refondue. 232 pages. Pet. 8°. Fr. 3.75.

NI EWENGLOWSKI, PROF. B. Cours de Géométrie Analytique a l'usage des élèves de la classe de mathématiques spéciales et des candidats aux écoles du gouvernement. Tome II. Construction des Courbes planes. Compléments relatifs aux coniques. 292 pages. 8°. Fr. 8.

PRASCH, ADOLF AND HUGO WIETZ. Die elektrotechnischen Maasse. Lehrbuch zum Selbststudium. Dargestellt und durch zahlreiche Beispiele und 38 in den Text gedruckte Figuren erläutert. 153 Seiten. 8°. M. 3.00.

SCHMIDT, DR. F. W. Kurzes Lehrbuch der anorganischen Chemie. Ein Repetitorium für Chemiker, Mediciner und Pharmaceuten. 376 Seiten. 8°. M. 4.50.

VERWORN, DR. MAX. Allgemeine Physiologie. Ein Grundriss der Lehre vom Leben. Mit 270 Abbildungen. 584 Seiten. gr. 8°. M. 15.

WASMANN, E. Kritisches Verzeichniss der Myrmekophilen und Termitophilen Arthropoden. Mit Angabe der Lebensweise und mit Beschreibung neuer Arten. 231 Seiten. gr. 8°. M. 12.

WINDRATH, DR. A. Die Medicin unter der Herrschaft des bacteriologischen Systems. 231 Seiten. 8°. M. 5.

WYSS, DR. HANS, V. Kurzes Lehrbuch der Toxicologie für Studierende der Medicin und praktische Aerzte. 212 Seiten. gr. 8°. M. 5.

WISLIGENUS, PROF. DR. WALTER F. Astronomische Chronologie. Ein Hülfsbuch für Historiker, Archäologen und Astronomen. 163 Seiten. 8°. Leinwandband. M. 5.

ZICKLER, PROF. KARL. Das Universal-Elektrodynamometer. Mit 8 in den Text gedruckten Figuren. 32 Seiten 8°. M. 1.

GUSTAV E. STECHERT,

810 Broadway, New York.

Macmillan & Co.'s New Publications.

NOW READY.

Analytical Chemistry.

By N. MENSCHUTKIN, Professor of the University of St. Petersburg. Translated from the third German Edition under the supervision of the Author. By JAMES LOCKE, Assistant in the Analytical Laboratory of the University of Heidelberg. pp. xii-512, 8vo, cloth. \$4.

Cambridge Natural Science Manuals.

General Editor—A. E. SHIPLEY, M. A., Fellow and Tutor of Christ's College.

New Volumes.

- I. **Elements of Botany.** By F. DARWIN, M. A., F. R. S., Fellow of Christ's College, Cambridge, and Reader of Botany in the University. With numerous illustrations. 12mo, \$1.60 *net.* (*Biological Science.*)
- II. **Petrology for Students.** By A. HARKER, M. A., F. G. S., Fellow of St. John's College, Cambridge University Demonstrator in Petrology. 13mo, \$2.00.
- III. **A Text-Book of Zoögeography.** By FRANK E. BEDDARD, M. A. (Oxon.), F. R. S., Prosector of the Zoölogical Society of London. Maps, 12mo, cloth, \$1.60, *net.* (*Biological Science.*)

Hydrodynamics.

By H. LAMB, M. A., F. R. S., Professor of Mathematics in Owens College, Manchester. Demy 8vo, cloth, \$6.25 *net.*

A Monograph on the Order of Oligochæta.

By FRANK EVERS BEDDARD, M. A. (Oxon.), F. R. S., Prosector to the Zoölogical Society of London, and Lecturer at Guy's Hospital. 4to, stiff boards, linen back, \$12.50, *net.*

Crystallography.

A Treatise on the Morphology of Crystals. By N. STORY-MASKELYNE, M. A., F. R. S., Professor of Mineralogy, Oxford, Honorary Fellow of Wadham College.

Second Volume of the Century Science Series.

Edited by SIR HENRY E. ROSCOE, D. C. L., etc. (Biographies of Eminent Men of Science.)

Major Rennell, F. R. S., and the Rise of English Geography. By CLEMENTS R. MARKHAM, C. B., F. R. S., President of the Royal Geographical Society. 12mo, cloth, \$1.25.

First Volume.

John Dalton and the Rise of Modern Chemistry. By SIR HENRY E. ROSCOE, F. R. S., etc. 16mo, cloth, \$1.25. (Other volumes of this Series in preparation.)

Short Studies in Nature Knowledge.

An Introduction to the Science of Physiography. By WILLIAM GEE, Certified Teacher of the Education Department and of the Science and Art Departments. Illustrated with 117 engravings, comprising portraits, views, etc. 12mo, cloth, \$1.10, *net.*

MACMILLAN & CO., 66 Fifth Avenue, New York.

SCIENCE

EDITORIAL COMMITTEE: S. NEWCOMB, Mathematics; R. S. WOODWARD, Mechanics; E. C. PICKERING, Astronomy; T. C. MENDENHALL, Physics; R. H. THURSTON, Engineering; IRA REMSEN, Chemistry; J. LE CONTE, Geology; W. M. DAVIS, Physiography; O. C. MARSH, Paleontology; W. K. BROOKS, Invertebrate Zoology; C. HART MERRIAM, Vertebrate Zoology; S. H. SCUDDER, Entomology; N. L. BRITTON, Botany; HENRY F. OSBORN, General Biology; H. P. BOWDITCH, Physiology; J. S. BILLINGS, Hygiene; J. MCKEEN CATTELL, Psychology; DANIEL G. BRINTON, J. W. POWELL, Anthropology.

FRIDAY, JULY 5, 1895.

CONTENTS:

| | |
|--|----|
| <i>The New York Botanic Garden:</i> G. L. GOODALE... | 1 |
| <i>The Submergence of Western Europe Prior to the Neolithic Period:</i> AGNES CRANE..... | 2 |
| <i>The Generic Name of the Water Weed:</i> N. L. BRITTON..... | 5 |
| <i>Notes on the Progress of Astronomy During the Year 1894:</i> —..... | 5 |
| <i>Minor Planets; Comets; Solar Parallax; Mars; Jupiter; Double Stars; Nebulae; Potsdam Photometry; Astrophotographic Chart; Astronomical Photography; Variation of Latitude; New Observatory:</i> J. K. REES. | |
| <i>Current Notes on Anthropology (X.):</i> —..... | 8 |
| <i>Is Craniology a Science? A Study of the Guaycuru; Why the Japanese Conquered:</i> D. G. BRINTON. | |
| <i>Current Notes on Physiography (XI.):</i> —..... | 10 |
| <i>Physiography of Cuba; Geologic Atlas of the United States; De L'apparent en Gemorphogeny; Bibliotheca Geographica; Jahrbuch der Astronomie und Geophysik:</i> W. M. DAVIS. | |
| <i>Notes on Agriculture (IV.):</i> —..... | 12 |
| <i>Artificial Pollination of Squashes; Peanut Culture; Some Plants That Look Like the Russian Thistle:</i> BYRON D. HALSTED. | |
| <i>Psychological Notes (I.):</i> —..... | 13 |
| <i>The Spectrum Top; 'Animal Magnetism:'</i> J. MCK. C. | |
| <i>Scientific Notes and News:</i> —..... | 14 |
| <i>Ancestry of the Mammalia; General.</i> | |
| <i>University and Educational News</i> | 15 |
| <i>Correspondence:</i> —..... | 15 |
| <i>Topographic Methods:</i> J. A. FLEMER. <i>The Meteorological and Magnetical Observatory Zi-Ka-Wei, Near Shanghai, China:</i> STANISLAS CHEVALIER, S. J. | |
| <i>Scientific Literature:</i> —..... | 18 |
| <i>The Royal Natural History:</i> RICHARD LYDEKER, C. H. M. <i>Ludwig's Lehrbuch der Biologie der Pflanzen; Small's Genus Polygonum:</i> Wm. TRELEASE. <i>The Geological and Natural History Survey of Minnesota:</i> EUGENE A. SMITH. <i>Folk Tales:</i> D. G. BRINTON. <i>The Second Law of Thermodynamics:</i> R. H. T. | |

| | |
|---|----|
| <i>Societies and Academies:</i> —..... | 25 |
| <i>Alabama Industrial and Scientific Society; St. Louis Academy of Science.</i> | |
| <i>Scientific Journals:</i> —..... | 26 |
| <i>The American Journal of Science. The American Chemical Journal:</i> J. ELLIOTT GILPIN. | |
| <i>New Books</i> | 28 |

MSS. intended for publication and books, etc., intended for review should be sent to the responsible editor, Prof. J. McKeen Cattell, Garrison on Hudson, N. Y. Subscriptions and advertisements should be sent to SCIENCE, 41 N. Queen St., Lancaster, Pa., or 41 East 49th St., New York.

THE NEW YORK BOTANIC GARDEN.

OUR country is to be heartily congratulated on the prospect that New York may soon be in possession of a Botanic Garden of the first order. The subscription prerequisite to the issue of municipal bonds has now been completed. It remains for the city to carry out its part of the agreement, by raising \$500,000 for building purposes and by providing 250 acres of land in Bronx Park or other suitable place. This action will probably be taken without unnecessary delay. Hence we may look forward with confidence to the speedy establishment, on a comprehensive and dignified scale, of a Botanic Garden of which the city and State may rightly be proud. But this successful effort has far more than a local interest or significance. It concerns the whole country.

To Columbia College and the other educational institutions of New York and vicinity, this new appliance for instruction will mean indeed a great deal. To all the citizens who are to take advantage of the

opportunities for instruction which the Garden will afford, Bronx Park will be a constant delight. But far beyond these limits, wide as they are, the Garden will exert a profound and beneficial influence. Other cities will surely be stimulated by this noble movement and enrich their park systems with an educational aid of the greatest value.

Formerly Botanic Gardens, attached even in a remote manner to educational institutions, were largely used for the cultivation of medicinal plants and for the reception of species from distant lands. Of course, this use, although its importance is now relatively less than ever before, will still long continue to be a factor in the direction of activities. But here and there new phases of plant relations are being displayed in the greater gardens, and with the most gratifying results. Geographical questions are asked and answered by skilful grouping of species, and in the most attractive way. The bearing of climate on the structure, habit and possibilities of plants is made prominent in an interesting fashion. The capabilities of useful plants and the extension of their range of usefulness comprise another phase of illustration which always sets visitors to thinking. Beyond and, we may say, above these questions, which are pretty strictly utilitarian, there comes nowadays another class of illustrations which are of the highest educational value in a community, namely, the biological features which are invested with such important relations to all departments of intellectual activity. The manifold relations of plants to their surroundings and to other organisms constitute in some of the botanical gardens of the present day the most attractive sections. The special interest in this can be more plainly seen if attention be called to the groups of climbing plants. Think of reading Darwin's work on climbing plants with the living illustrations be-

fore one! This is only one of many stimulating exhibitions in a garden adapted to modern wants.

The Arnold Arboretum, a department of Harvard University and an adjunct of the Boston Park system, has become one of the most charming places for certain studies of a general nature within reach of the public of Boston. And yet it is confined chiefly to woody plants. Without such limitations the New York Garden may, perhaps, offer even a wider field for general study to the public now so eager to learn something about nature at first hand.

With the secure foundation of the New York Garden, three of our cities will be well provided with botanical establishments of the highest class. We venture to hope that many other cities will soon emulate the example of Boston, St. Louis and New York. GEORGE LINCOLN GOODALE.

HARVARD UNIVERSITY.

*THE SUBMERGENCE OF WESTERN EUROPE
PRIOR TO THE NEOLITHIC PERIOD.*

THE veteran geologist and archæologist, Professor Joseph Prestwich, has recently contributed a suggestive memoir on this subject to the Philosophical Transactions of the Royal Society.* It treats of 'the evidence of a submergence of Western Europe and of the Mediterranean coasts at the close of the glacial or so-called post-glacial period and immediately preceding the neolithic or recent period,' and is accompanied by an original map showing the chief areas submerged.

The memoir deals in turn with the character and distribution of 'rubble drift' loess, breccia, ossiferous fissures, raised breaches, bone caves, shell beds, and presents the results of many years research over this wide field. In a previous paper, communicated to the Geological Society of

*Vol. 184, 1893, A., pp., 903-934. Plate 33. Price 5 s. 6 d.

London in 1892,† the author gave the evidence deduced from personal observation of the submergence of the south of England not less than 1000 feet between the glacial or post-glacial and recent or neolithic period and proposed the term 'rubble drift' for the peculiar superficial drift then deposited. In the memoir under notice Professor Prestwich cites the phenomena he relies on as proofs of this submergence in England and traces their extension over large continental areas.

The author describes the 'rubble drift' as sometimes simulating other drift deposits, but maintains that it cannot be included with them on account of its varied physical distribution and faunal divergences. It is distinguished chiefly by the absence of all marine and fluviatile shells; the included remains are those of land animals and land shells alone, and of land plants derived from a land surface only. He points out that mammalian bones from the ordinary Quaternary deposits are very fragmentary, characterized by the absence of wear and also devoid of traces of gnawing in contradistinction from those of the caves, 'which have commonly been gnawed by predaceous animals,' and from those of the fluviatile deposits, which are usually worn.

The *detritus* of the 'rubble drift' is always of local origin, and as a rule unstratified. Professor Prestwich considers therefore that it can only be accounted for by an upheaval of a submerged land surface after widespread submergence, the consequent divergent effluent currents of water sweeping the *detritus* of the submerged surface from the higher to the lower levels. "A body of water 1,000 feet deep forms an engine of enormous power." He maintains that all the phenomena of this 'rubble drift' are explicable only upon this hypothesis.

The 'rubble drift,' widely, if sparsely, spread over the Southeast of England, can

be traced over much of western Europe and the Mediterranean coasts. It has been personally observed by him in parts of France and Italy. Other geologists have noted similar phenomena elsewhere without attempting to account for their origin. Professor Prestwich holds it to be impossible that the confusing accumulations of superficial debris lying on the surface of the land without apparent order or stratification could all be due to the *transient* action of water, and that glacial, fluviatile and meteoric action fail to account for *all* the phenomena. To the residue he applies the name of 'rubble drift,' as distinguished from the term *diluvium*, which is still variously employed on the continent to denote fluviatile, sub-terial and other drift beds, and does not include the more important phases of the 'rubble drift' period, "which marks the last stage of a long series of earth movements of variable intensity and duration." "Whilst admitting the permanence of the laws of nature, it is impossible to suppose that at all former periods the effects produced by these laws, though not equal in kind, were equal in degree."

The absence of marine sediments in the 'rubble drift' is not to be regarded as fatal to his theory if the submergence were of short duration, which would also militate against the migration and establishment of a marine fauna on the submerged area. All the component materials of the 'rubble drift' are of local origin. It includes remains of a land fauna alone, the mammalian bones are ungnawn yet sharply fractured. The submergence hypothesis he includes not only 'meets the requirements of each particular case, but shows them all to be concordant, and such as would pertain to one common and general cause.'

Professor Prestwich thus proceeds to restate his long-held convictions that Croll's estimate of the lapse of 80,000 years since the close of the glacial period is not sup-

† Quarterly Journal Geological Society of London, vol. 48, p. 263. 1892.

ported by geological facts, nor the history of the development of human culture. Progressive early quarternary man could not have remained stationary for 70,000 years without advancing further than the status attained by 'man of the early stone period.' "There is nothing to represent geologically that long period of time, nor have biologists been able to detect any essential structural differences between paleolithic man and neolithic man in support of such a conclusion; all the evidence tends, on the contrary, to prove that late glacial (or post-glacial man), together with the great extinct mammalia, came down approximately to within some 10,000 to 12,000 years of our own time, and that the 'rubble drift' marks the stroke of the pendulum when the glacial period came to a close and the Neolithic age 'commenced.'"

It is well known that the stern repression of the physicists has compelled the majority of geologists and biologists to make considerable reductions in their estimates of the duration of geological time and of the ages requisite for the evolution of life on the earth. These conjectures have varied from Mr. J W McGee's revised maximum of six thousand millions of years to Professor Winchell's modest minimum of three millions. Mr. C. D. Walcott, who has recently passed this subject in review (*American Geologist*, December, 1893), came to the safe conclusion that "the earth is very old and that man's occupation of it is but a day's span compared with the eons that have elapsed since the first consolidation of the rocks with which the geologist is acquainted."*

With regard to the approximate duration of this 'span,' however, quarternary geologists and archaeologists are by no means agreed. Mr. Warren Upham would extend

its limits to 100,000 years at least. Professor Prestwich would make it much shorter. He ascribes from 15,000 to 25,000 years to the glacial epoch, and to the post-glacial period at most 10,000 years; from 20,000 to 30,000 years in all to paleolithic man. (*Quart. Journ. Geol. Soc.*, London, p. 407 Vol. 43, 1887).

Historic archæologists, on the other hand, are daily accumulating evidence that the dawn of civilization was remote from our era, that the arts and sciences began long, long ago. Drawing, painting, sculptures, writing, calculating and astronomical observations were fully developed and widespread at the earliest historical period, and their origin lies far beyond our ken. The researches of Prof. Norman Lockyer have revealed a knowledge and practice of the elements of astronomy in the Old World as far back as the history of Egypt and Asia Minor can be traced, while those of Mrs. Zelia Nuttall on 'the calendar system of the Ancient Mexicans' have demonstrated the hitherto unsuspected facts that such knowledge was developed and observations practiced in the New World at an almost equally remote period of time.

Of a truth there is no finality about science. The enunciation of modern theories postdating the antiquity of man coincides with facts antedating the dawn of human civilization. Unless we may assume with Professor Prestwich, that the two periods overlapped in Europe and Asia, that while man in a more advanced state flourished in the East he may have been in one of his later post-glacial stages in the West, or are permitted to apply to human culture the principle of 'accelerated development' so dear to American biologists, the reconciliation of two such apparent contradictions must still be left a 'Problem of the Future.'

AGNES CRANE.

BRIGHTON, ENGLAND.

* The majority of estimates now range from fifty to ninety-five millions, more than one hundred millions less than Darwin suggested as the age of the world.

THE GENERIC NAME OF THE WATER-WEED.

THE first generic name applied to our common Water-weed or Ditch-moss was *Elodea*, published by Michaux (Fl. Bor. Am. I: 20. 1803), who gave a description accompanied by a figure of the North American plant specifically designated by him *Canadensis*. This name was unavailable on account of the prior publication of *Elodes* Adans. (Fam. Pl. 2: 444. 1763), the same word with a different spelling. Adanson's genus was based on *Hypericum Ægypticum* Linn.; it has been accepted by Payer (Organog. 8, pl. I.). *Hypericum Ægypticum* was also made by Spach the type of the genus *Triadenia* (Ann. Sci. Nat. II. 5: 172) as *T. microphylla*. It is noteworthy that Spach in the paper above cited credited Adanson with the name *Elodea* and founded a new genus *Elodes* in addition, thus complicating the synonymy of these Hypericaceæ in an extraordinary manner.

Elodea Michx., being thus clearly untenable, authors have at different times proposed no less than six generic names for the Water-weeds. In seeking for the oldest of these, Morong (Mem. Torr. Club, 5: 27) has recently accepted *Udora* Nutt. (Gen. 2: 242. 1818), but *Philotria* Raf. (Am. Month. Mag. 2: 175. Jan. 1818) was published a few months earlier, and appears to be the first available for these plants. The North American species is *Philotria Canadensis* = *Elodea Canadensis* Michx.

N. L. BRITTON.

NOTES ON THE PROGRESS OF ASTRONOMY DURING THE YEAR 1894.*

MINOR PLANETS.

TWENTY-THREE new planets were discovered. Permanent numbers have been assigned from 379 to 390, both inclusive. Eleven have, as yet, been unnumbered, as

* Based mainly upon the *Annual Report of the Royal Astronomical Society of London*. February, 1895. Prepared at the request of the responsible editor.

the investigations in regard to their orbits are not sufficiently complete.* The discoverers were as follows: Charlois at Nice 11, Courty at Bordeaux 2, Wilson at Northfield, Minn., 1, Wolf at Heidelberg 6, Bigourdan at Paris 1, Borely at Marseilles 1, Roberts at Crowborough 1.

Minor planets are now picked up so rapidly by photography and other methods that, to avoid confusion in the numeration, Prof. Kreuger, of Kiel, assigns a provisional rotation (A, B, C, etc., BA, BB, BC, etc.), arranged in order of their announcement to the 'Telegraphische Central-Stelle.' The final number is assigned by Prof. Tietzen, Director of the Rechen-Institut in Berlin. Numbers are assigned to those planets only for which sufficient observations are available for a determination of the orbits. Names are given by the discoverers.

Planet BE discovered November 1, 1894, by Wolf, is unique, having the smallest perihelion distance of all the minor planets, except possibly No. 323, Brucia, which was named after Miss Bruce of New York City, on account of her generous contribution to astronomical work. The least distance of BE from the earth and Mars are about 63 and 21 millions of miles. It seems to be well adapted for determining Solar Parallax.

Prof. E. E. Barnard measured, during the year, the diameters of Ceres, Pallas and Vesta with the great telescope of the Lick Observatory and obtained the results as follows: Ceres, 520 miles; Pallas, 304 miles; Vesta, 241 miles. These planets are the largest of the family.

COMETS.

Five comets were discovered.

(a) Denning, of England, picked up the first on March 26, 1894.

Investigations seem to show that this

* Numbers have since been assigned up to and including 401.

comet makes a close approach to Jupiter (about 18,000,000 of miles). The orbits of Brorsen's and Denning's comets appear to intersect. Brorsen's comet passed the intersecting point February 7, 1881, and Denning's comet reached that point March 14, 1881. Perturbations may bring about a collision.

(b) On April 3, 1894, the second comet was found by Gale, of New South Wales. He used a telescope with object glass only 3 inches in diameter. The comet had a tail 4° in length. Prof. Barnard has studied this comet with unusual care and taken some exquisite photographs which reveal many details deserving most careful investigation.*

Twenty lines were seen in the comet's spectrum. The orbit seems to be a parabola.

(c) By the aid of an ephemeris prepared by Schulhof, this second return of Tempel's comet, first seen in 1873 and observed in 1878, was found by Finlay at the Cape of Good Hope on May 8. The error in the assigned place was only 9 seconds of time in right ascension and 30 seconds of arc in declination. This discovery is a 'recovery' of a comet after sixteen years.

The comet has a period of 5.2 years and is one of the fifteen periodic comets of which at least one return has been observed.

(d) Encke's comet belongs in the same class with the preceding comet and is one of the most interesting objects to the astronomers. It was originally discovered by Pons, of Marseilles, November 26, 1818. Professor Encke worked out its orbit and found it to be $3\frac{1}{2}$ years, or 1208 days, the shortest period of any known comet. It showed a continued acceleration in its motion to 1868, so that the time of each revolution about the sun was shortened by about $2\frac{1}{2}$ hours. After 1868 the acceleration appeared to be diminished by one-half.

*See *Astronomy and Astrophysics* for June, 1894.

The cause of this peculiar acceleration was first thought to be due to a 'resisting medium' in space or near the sun, but that theory is now abandoned and the idea is gaining ground that there is some undetected perturbation due to planetary attractions.

The thirty-third return of this comet was discovered independently by three observers, Perrotin at Nice, Wolf at Heidelberg and Cerulli at Teramo, on October 31 and November 1. All these astronomers were aided by the ephemeris calculated by Backlund.

(e) E. Swift, son of Lewis Swift, formerly of the Rochester observatory but now located in California at the Lowe Observatory, discovered on November 21st the last comet of the year 1894. There seem to be good reasons for believing this comet to be the 'lost or mislaid' comet found by De Vico at Rome, August 22, 1844. It was expected to return in 1850, but 'failed then and subsequently to keep its appointment.'

SOLAR PARALLAX.

Dr. Arthur Anwers published Volume V. on the *German Heliameter Observations of the Transits of Venus, 1874 and 1882*. In this volume the discussion of the observations is given. The final value of the Solar Parallax from the two transits is $8''.896 \pm 0''.0216$. This corresponds to a distance of 91,000 000 miles. This value differs considerably from the value $8''.81$ obtained by Harkness in 1891.*

MARS.

This planet was in better position for observation during the opposition of 1894 than that of 1892, although the planet was farther from the earth. Observers have noted that the south polar spot completely disappeared; that during the gibbous phase there were irregularities seen at the termin-

**Solar Parallax and its Related Constants*.

ator which indicated mountains; that the canal system of Schiaparelli was generally confirmed, as well as the duplication of a number of the canals.

Excellent work was done by the observers at the Lowell Observatory Flagstaff, Arizona, in detecting additional canals and delicate details.

Some of the results of Mr. Lowell's expedition to Arizona have been published in the *Astrophysical Journal* for May, 1895.

Evidence has been obtained that at times vast areas are densely obscured by clouds. Several observers agree in noting that actual changes have taken place since 1877.

Professor Campbell, of the Lick Observatory, made observations of the spectrum and has found no lines due to an atmosphere on the planet Mars.

This is in opposition to other evidence. Campbell's apparatus was more powerful than that used by the other observers.

JUPITER.

The new satellite of Jupiter is so small and its proximity to the parent planet is such that the satellite can be measured only in the largest telescopes.

Barnard was able to make at the Lick Observatory observations which make a good basis for a more accurate determination of the orbit. The periodic time is $11^h 57^m 22^s.618 \pm 0^s.013$. The orbit is eccentric. Tisserand has shown that the major axis should make a complete revolution in about five months. Barnard prefers the name Satellite V.

Barnard sees on Satellite I dusky poles and a bright equatorial belt. These observations seem to explain the ellipsoidal and double appearances reported by other observers.

DOUBLE STARS.

The British Royal Astronomical Society presented in February, 1894, its Gold Medal to S. W. Burnham, formerly of the

Lick Observatory, for his discoveries, measures and general work on Double Stars. In volume II. of the Publications of the Lick Observatory is given a great proportion of Burnham's recent work.

At the Georgetown College Observatory experiments were made with a 12-inch refractor. Fifteen wide pairs were photographed. The results of the measures were not encouraging.

During the year Prof. Glasenapp published his observations of 1220 measures on 610 pairs, made at Abastoman.

The orbits of ten double stars were computed and published during the year. The periods vary from 11.37 years, in the case of *K Pegasi* to 208.1 years for γ Cassiopeia.

NEBULÆ.

In *Astronomy and Astrophysics* for May Prof. Campbell, of the Lick Observatory, gave a table of bright lines photographed in the spectrum of the Orion nebula; of dark lines photographed in the spectra of the Orion stars and of the comparison of bright nebular and dark star lines. He concludes that nearly all the dark lines in the faint stars are matched by bright lines in the nebula, but certain prominent nebular lines are not matched by dark stellar lines.

The stars appear to be closely related to the nebula in chemical constitution and may be physically connected.

Prof. Keeler, from his observations at the Lick Observatory, drew the conclusion that the distance of the great Orion nebula from the sun is increasing at the rate of 11 miles per second. No relative motion of the different parts of the Orion nebula was detected. His investigations seem to show that nebulae are moving through space with velocities similar to that of the stars.

POTSDAM PHOTOMETRY.

Drs. Müller and Kempf have completed, in its first stage, the investigation of the

visual magnitudes of all stars recorded as fainter than 7.5 magnitude in Argelander's *Durchmusterung*, lying in the zones between north declination 0° to 20° . In a few years they hope to complete the investigation to the North Pole.

This research is the most accurate and complete of modern researches in the direction of photometric study of stellar magnitudes.

ASTROPHOTOGRAPHIC CHART.

Seven of the associated observatories have taken more than one-half the required catalogue plates. All these plates will be taken in two or three years.

The measurement of the catalogue plates was begun at the Paris Observatory.

The chart plates will not be completed probably until 1900.

ASTRONOMICAL PHOTOGRAPHY.

IN volume III. of the Lick Observatory publications are reproduced several fine enlargements of lunar photographs taken with the 36-inch refractor cut down to eight inches. These enlargements were made by Dr. L. Weinek, of the Prague Observatory. In addition Dr. Weinek has published some excellent enlargements of moon photographs taken by M. M. Loewy and Puiseux at Paris.

In February, 1895, the Royal Astronomical Society presented its Gold Medal to Dr. Isaac Roberts for his photographs of star clusters and nebulae published in 1894. These superb photographs were taken with silver-on-glass reflector of 20-inch aperture and about 100 inches focal length. Professor Barnard, of the Lick Observatory, exhibited, at the R. A. S., an exquisite set of sixty positives, on glass, of stars and comets. The publication of these photographs is under consideration by the Society. The Council of the R. A. S. is also at work on a method for reproducing the fine photo-

graphs recently made and for making the reproductions permanent.

VARIATION OF LATITUDE.

Dr. Chandler showed that there are two terms in the variation of latitude. One term with a period of a year, the other with a period of 428.6 days. He suggested that the pole rotates, not in a circle, but in an ellipse with revolving line of apsides.

During the year there was published the results of observations made in various parts of the world, including Prof. Doolittle's work at Bethlehem, Pa., and Prof. Davidson's observations at San Francisco.

NEW OBSERVATORY.

Mr. Percival Lowell, of Boston, established an observatory at Flagstaff, Arizona, at an elevation of 7,300 feet above sea level. His principal instrument was formed by a combination of two telescopes with apertures of 18 and 12 inches. These telescopes were mounted like a twin instrument.

Mr. Lowell, Professor W. H. Pickering and Mr. Douglass have given most of their time to the study of Mars. Extensive reports have been made in *Astronomy and Astrophysics*.
J. K. REES.

COLUMBIA COLLEGE.

CURRENT NOTES ON ANTHROPOLOGY (X.).

IS CRANIOLGY A SCIENCE?

Two years ago (June, 1893) I pointed out in these notes how completely craniology, as it has been pursued, has failed of the promises which Broca and Retzius and its other founders made for it.

A far more forcible and detailed indictment of its inefficiency has just appeared from the pen of Professor Burel von Török, Director of the Anthropological Museum at Budapest, himself an eminent craniologist, in the 'Archiv für Anthropologie,' Band XXIII. He says of the science: "All the great possibilities which were attributed to

it have proved illusory.' The causes of this utter failure he finds mainly in the false methods which have been pursued; and partly in expecting from it results which in the nature of things it could never reach.

He does not give it up as worthless, but suggests more minute and extended investigations and measurements, reduced by mathematical formulas to averages and means, which will indicate probabilities, the higher as the observations are extended. He exemplifies his suggestions by several collections of Aino skulls, which he endeavors to analyze by numerous and extended calculations.

No one can deny the justice of his criticisms, and in a general way we must grant the correctness of his procedure; but, after all, it seems to me that his own method of means lacks the necessary noting of the frequency of extremes; in other words, it fails just as the mean temperature, monthly or annual, of a locality is practically no guide whatever to its climate, and fails for medical purposes. The range, daily and weekly, etc., is the only temperature test. The analogue to this, if I apprehend his method, Prof. von Török does not give in craniology. His article, however, is most important as pointing out present deficiencies.

A STUDY OF THE GUAYCURU.

A BOOK which is at once a 'thing of beauty' and a work of solid instruction is one by Guido Boggiani, entitled 'I Caduvei; Viaggi d' un Artista nell America Meridionale' (Roma, Loescher & Co. 1895). The Caduvei are the Indians of the Chaco, better known as the Guaycurus, among whom the author spent many months studying their habits, arts and mode of life. He presents his observations in a pleasant literary form, and his pages are adorned with more than a hundred admirable illustrations, while a well-drawn map enlightens

the reader as to the geographical relations of the journey. So much in the latter direction is new that the Geographical Society of Italy has officially joined in the publication.

The Americanist is especially benefited by an 'Historical and Ethnographical Study,' by Dr. G. A. Colini, added to the volume. It presents a well-arranged vocabulary of the dialect, with remarks on its grammar and affiliations, and a review of what previously has been written about them. The art designs of the tribe are especially interesting and are exemplified by numerous illustrations.

WHY THE JAPANESE CONQUERED.

THIS is the title of an article by Otto Ammon in the *Naturwissenschaftliche Wochenschrift*, March, 1895. It is appropriate for comment here, because the author announces that the true answer is an anthropologic one; the Japanese conquered because they had a class of nobles, who were the virtual rulers of the nation, and who were of another and higher race than the lower classes. For this statement he quotes Dr. Doenitz and Professor Baeltz; and from what higher race, think you, they are descended? From the Semites! Not the 'ten lost tribes,' as one would naturally suppose, but from the ancient Akkadians of Babylonia!

This higher type he defines as narrow faced and with long skulls (dolichocephalic). Generalizing further, the author finds that in Europe, too, the higher type has these characteristics. The finest examples are naturally among the Germans, and the best of all was old General Von Moltke himself. The author indulges in gloomy anticipations about France, because it has destroyed the power of the old nobility, and about the present condition of Europe generally, because the political influence of the higher classes is diminishing, and individuals of a

lower ethnic type are coming to the front in statesmanship.

It is not likely that many citizens of the United States will deeply sympathize with our author in this anthropological pessimism.

D. G. BRINTON.

CURRENT NOTES ON PHYSIOGRAPHY (XI).

.PHYSIOGRAPHY OF CUBA.

MUCH excellent physiographical material may be found in R. T. Hill's recent 'Notes on the Geology of the Island of Cuba' (based on a reconnaissance made for A. Agassiz; Bull. M. C. Z. xvi., 1895, 243-288, maps and plates). One chapter, entitled 'Geologic history recorded by the topography,' is an excellent example of physiographic methods, which the author knows so well how to employ. The mountains of the interior are described as residual masses rising above a dissected peneplain; while the coast, especially around the eastern end of the island, is fringed with sea-cut benches terminating inland in strong sea cliffs. Hill differs from certain other writers in not regarding the ragged outline of Cuba as indicative of submergence, no downward movement being proved since the beginning of Tertiary time.

GEOLOGIC ATLAS OF THE UNITED STATES.

THE folios of maps and text issued by the United States Geological Survey are providing sound physiographic descriptions of various parts of the country. One of the latest, the Estillville sheet, including parts of Kentucky, Virginia and Tennessee, by Campbell, classifies the surface forms with reference to the two well-marked peneplains that have been produced in the Appalachian province: the Cretaceous peneplain of the now dissected uplands; the Tertiary peneplain of the valley floors, now trenched by the rivers. The head of Powell's valley, included in this map, is a region of remarkable geological and topographical interest,

well adapted to summer field-work for the geological students of southern universities. It may be noted that in naming the three main divisions of the Appalachian province, Campbell does not employ the usual term, Alleghany plateau. While the central division is all included in the 'Appalachian valley,' comprehending the linear ridges as well as the associated lowland, and while the diverse forms of the eastern division are named the 'Appalachian mountains,' yet the western division is called 'the Cumberland plateau and the Alleghany mountains;' no general name being here suggested. It seems unfortunate that the many similar features of this division should not be taken as sufficient reason for giving it some single general name, under which sub-divisions might be afterwards recognized when needed.

DE LAPPARENT ON GEOMORPHOGENY.

PROFESSOR A. DE LAPPARENT, president of the Société de Géographie at Paris, contributes an article on *La Géomorphogénie* to the *Revue des questions scientifiques* for April, based in good part on American writings on this subject. He applies the physiographical methods to certain French problems, calling especial attention to the diversion of the Moselle from the Meuse to its present course below Toul. Few foreign writers have shown so full an appreciation as is here manifested of the systematic sequence that characterizes the development of topographical forms during the long process of baselevelling a region.

BIBLIOTHECA GEOGRAPHICA.

THE *Gesellschaft für Erdkunde* of Berlin has for many years published in its *Zeitschrift* an annual summary of geographical literature prepared by its secretary, Dr. Koner, from 1853 until his death in 1887. The summary was continued for 1887 and 1888 by Fromm, for 1889 by Wolfsteig, and for 1890 by E. Wagner. Twenty-five years

ago, the list filled 90 pages; ten years ago, 130 pages; for 1890, 270 pages. With the recent changes of editors, the preparation of the lists was much delayed; and hence it has recently been decided to issue an independent bibliography, the *Bibliotheca Geographica*. Its preparation was placed in the hands of O. Baschin, and the first number for 1891 and 1892 has been recently issued in an octavo volume of 506 pages. Another number for 1893 will soon appear, and thenceforwards regular annual volumes will follow. The titles are carefully classified, first under various subdivisions of mathematical, physical and other general aspects of geography, then by countries. Presumably on account of the great amount of space demanded for even the briefest abstracts or critical notices, and probably also because the notices in *Petermann's Mittheilungen* suffice so well for the more important works, nothing but the author's name, the title of his paper, and the reference to its place of publication are given, with abbreviated indication of maps, tables and illustrations. If the *Bibliotheca* can be uniformly prepared and promptly published, it will become a standard work of reference.

JAHREBUCH DER ASTRONOMIE UND GEOPHYSIK.

THE fifth number of this useful annual, edited by Dr. H. J. Klein and published by Mayer, of Leipzig, treats of publications of 1894 and shortly preceding dates. It contains critical abstracts of a good number of the more important books and papers; the headings which concern physiography being topographical form in general, volcanoes and earthquakes, coastlines, the sea, rivers, lakes, glaciers, and meteorology in various subdivisions. Although not intended to be a complete bibliographic reference book, this annual must prove valuable to those who wish for a condensed statement of the best new material on physiological subjects.

GLACIAL LAKES OF WESTERN NEW YORK.

THE Mohawk valley and the basins of the Great Lakes lie in a subsequent depression that follows the strike of weaker strata (chiefly Silurian) between the old-land area of resistant crystalline rocks on the north and the uplands of harder Devonian and Carboniferous strata forming the Alleghany plateau on the south. When this region first rose from the paleozoic sea, the drainage probably followed the dip of the strata, from the crystalline old-land southward even to the plateau area, after the ordinary habit of streams extending their courses across young coastal plains; but this was so long ago and there has been on all accounts so good an opportunity of rearrangement of drainage lines in later time that the St. Lawrence system now diverts all the headwaters along the lateral line of escape opened on the weaker Silurian strata; and the southward flowing streams of the plateau are reduced to moderate length by progressive beheading. A temporary return to ancient drainage conditions was, however, made during the glacial period, when the subsequent lowland along the weaker strata was filled by ice, and a general slope southward from Canada was restored. Then for a time water was discharged as it was originally; the beheaded streams in the plateau gained short-lived headwaters, either flowing directly from the margin of the ice sheet, or through intermediate lakes which were constrained to overflow into the southward streams by the obstruction of the retreating ice wall on the north. It is the memorials of these lakes that Fairchild describes in a preliminary essay under the above title (*Bull. Geol. Soc. Amer.*, vi., 1895, 353-374), with especial reference to their deltas and outlets. The paper is an admirable beginning of a study which we hope the author may pursue at length.

W. M. DAVIS.

HARVARD UNIVERSITY.

NOTES ON AGRICULTURE (IV.)

ARTIFICIAL POLLINATION OF SQUASHES.

MR. L. C. CORBITT in his Bulletin (No. 42 South Dakota Experiment Station) upon squashes observes that in Dakota there is an abundant production of flowers of the squash plants, but 'an almost complete failure of fruit.' For two years he has been experimenting to find the cause and concludes that the failure is due to an absence of insects capable of transferring the pollen from the male to the female flowers. In their absence it is further demonstrated that profitable crops of squashes can be grown by resorting to artificial pollination. This pollination is best effected in the early morning and consists in touching the stamens of a male flower, picked off and held in the hand to the large fleshy stigmas of the pistillate flowers, which are, of course, left on the vines. It was found that 62 per cent. of the flowers thus treated produced fruit, while practically none will grow if left dependent upon nature for the transfer of the pollen.

PEANUT CULTURE.

THE Office of Experiment Stations of the U. S. Department of Agriculture has reached the 25th number of its Farmers' Bulletin, and Mr. Handy in this issue condenses a large mass of facts upon peanut culture and uses. It is only within a few years that the peanut has become an important crop in this country, the climate of the Atlantic seaboard and the Mississippi Valley proving very congenial to it. Peanuts desire a fine soil, kept loose and free from all weeds. After the vines are lifted, the growers stack them for two weeks, when the pods are removed, placed in bags and stored in well ventilated sheds. The larger portion of the crop is sold by street venders, while some are used in extracting a peanut

oil. The peanut is an interesting plant in that the pods mature underground while the ordinary pea does not.

SOME PLANTS THAT LOOK LIKE THE RUSSIAN THISTLE.

IN Bulletin No. 39 of the Illinois Experiment Station, Mr. Clinton, the assistant botanist, brings out by means of text and engravings, some of the plant rogues that resemble the Russian Thistle, mentioned in a late issue of SCIENCE.

Among those of special mention are the winged pigweed (*Cycloloma atriplicifolium* (Sp.) Coult.), one of the plants of the Plains. It is easily distinguished from the Russian Thistle by its flat leaves of the ordinary sort. In the autumn this plant by breaking away from the soil at the root becomes one of the noted 'tumble weeds.' Another species of weed quite closely related to the last, and likewise a 'tumbler,' is the *Amarantus albus* L. It is not confined to the West, but may be found in many an Eastern neglected field. This Amaranth has a first cousin that is spinose (*A. spinosus*, L.), and for this reason is easily mistaken for the Russian pest. Somewhat more remote as regards botanical relationship is the Horse Nettle (*Solanum Carolinense*, L.), which is akin to the tomato, egg plant and potato. It has yellow pickles and berries. The Texan horse nettle or 'sand bur' is even worse than the last, to which it is closely related. It is *Solanum rostratum*, Dun. Of course, it would be a fault of omission not to mention the Canada Thistle in this connection, as it is one of the most despised of the prickly weeds. There is a prickly lettuce (*Lactuca Scariola*, L.), common in the West, that is like the Russian intruder, but easily distinguished from it by the flat leaves, which are polar, and the species is a compass plant.

BYRON D. HALSTED.

PSYCHOLOGICAL NOTES (I.).

THE SPECTRUM TOP.

RECENT numbers of *Nature* have contained not fewer than eleven communications on 'a spectrum top,' and the instrument has been extensively discussed in *La Nature*, *The Scientific American* and other journals. Yet none of the writers seem to know that the phenomena were described by Fechner in 1838 (*Poggendorff's Annalen*), and were given a careful quantitative study and correct explanation by Rood in 1860 (*Am. Journal of Science and Arts*). They have also been discussed and illustrated by Brücke (*Wiener Akad.*, 1864); by Aubert (*Physiologie der Netzhaut*, 1865), and by others. Indeed Aristotle described the colored images following the exposure of the eye to white light. In view of these facts, it is somewhat amusing to find that Messrs. Newton & Co. write to *Nature* (March 14, 1895) that anyone supplying the tops will be infringing their copyright.

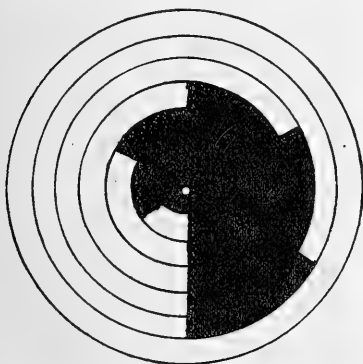

The form used by Aubert is shown on the accompanying figure. If such a disk (best enlarged) be revolved 10 to 40 times per second colors will appear, varying with the rate of revolution, the intensity of the light, the observer, etc. Under favorable circumstances the colors may be of

great brilliancy. They are undoubtedly subjective, being due to the fact that the components of white light vary in the time they require to call up a sensation, and in the time the sensation continues after the light has been withdrawn. But while we may refer these phenomena to inertia and fatigue, we are very far from having a satisfactory theory of all the facts of color vision.

'ANIMAL MAGNETISM.'

WHEN a work on hypnotism is issued as the thirty-fifth volume of a series of electro-technical primers, we do not look for a critical treatise. Nor do we find one in *Magnetismus und Hypnotismus* by G. W. Gessmann (Hartleben, Vienna). A full-page picture of 'Lina' in the attire and attitude of a Sybil, reading a closed book through the top of her head, is scarcely a part of modern electrical science. The work is in a way more interesting than others of the long series of articles and books describing in endless repetition the well ascertained phenomena of hypnotism—more interesting not only to the credulous, but also to men of science, owing to the historical references to Greek oracles, demoniac possession, miraculous cures, Reichenbach's 'od,' etc. Still such books do harm by making a subject notorious through the popular interest in the abnormal and the marvelous, and really prevent the scientific investigation of hypnotism and its use as a therapeutic agent. Experiments on hypnotism by untrained observers have much the same results as giving or taking 4 ounces of alcohol in order to study the phenomena of intoxication. Hypnotism, dreaming and somnambulism, intoxication, delirium, hysteria, insanity, etc., are related phenomena the study of which has thrown much light on the normal workings of the mind, but they are phenomena that can be studied to advantage only by students skilled in psychology, physiology and pathology. J. McK. C.

SCIENTIFIC NOTES AND NEWS.

ANCESTRY OF THE MAMMALIA.*

PROFESSOR A. A. W. HUBRECHT recently presented a paper to the Amsterdam Academy of Science summing up his researches upon the origin and bearing upon the problem of mammalian ancestry of the Amnion. This fetal envelope distinguishes the reptiles, birds and mammals from the Amphibians and fishes, yet Professor Hubrecht finds that the mode of development of the Amnion in some of the mammalia is even more primitive than that in the reptilia and can be theoretically derived from the outer epiblastic layer of the Amphibian embryo. He is thus led to support the hypothesis Huxley advanced in 1880, that the mammalia originated in a pre-reptilian, if not actually an Amphibian stock. Since, further, the three great divisions, Monotremes, Marsupials and Placentals show distinct modes of Amnion development, and among the latter the Insectivora are extremely primitive. He reaches the following conclusions as to the relations of the mammalia: that the three great divisions arose independently from a common Protamniote Amphibian-like stem; the theromorph reptilia are not to be regarded as transition forms to the mammals, but as parallel forms; the ancestry of the insectivora dates back to the time of origin of the monotremes and marsupials. He shows that his own conclusions based upon embryology are so far as concerns the polyphyletic origin of the mammalia, the mesozoic origin of the insectivora, and the parallel position of the theromorpha, in close agreement with the paleontological position of Miart, Osborn and Baur, while as regards the protamniote or Amphibian character of the stock he approaches Huxley and Howes.

H. F. O.

*"Die Phylogenese des Amnions und die Bedeutung des Trophoblastes," Verh. d. Kon. Akad. v. Wet. te Amsterdam, Dl. IV., No. 5.

GENERAL.

THOMAS H. HUXLEY died on the afternoon of June 29th at the age of 70 years.

CHARLES GRIFFIN & Co. have published the twelfth annual edition of the *Official Year-Book of the Scientific and Learned Societies of Great Britain and Ireland*, a work of reference of great value to all interested in the current advance of science. It contains details concerning the officers, place and time of meeting, publications, etc., of the various societies, and lists of the papers presented during 1894. The book bears witness to the widespread activity in all departments of science which characterizes Great Britain and Ireland.

DR. D. MORRIS, Assistant Director of the Royal Gardens, Kew, in a lecture delivered before the Royal Horticultural Society, stated that, contrary to general opinion, the native plants in the Canary Islands were not dying out; they appeared, owing to their special characters, to hold their own against introduced plants and were likely to increase rather than decrease in the future. The number peculiar to the Canarian Archipelago was about 400.

ABOUT 150 members of the American Institute of Electrical Engineers were present at Niagara Falls on June 25th, to witness the trial of one of the 5,000 horse power dynamos of the Niagara Electric Power Co.

SIR ROBERT BALL, professor of astronomy in the University of Cambridge, England, in an article in the July number of *McClure's Magazine*, attempts to show that recent scientific discoveries tend to bear out early speculations in favor of the existence of life on other planets than the earth.

MR. HERBERT SPENCER has been elected an honorary member of the Vienna Academy.

SIR B. BAKER has been elected President of the Institute of Civil Engineers for the coming year.

IN the *Atlantic Monthly*, Mr. Percival Lowell, in the third of a series of papers on the planet Mars, takes up the subject of the canals and discusses their artificial appearance.

THE death is announced, in Underhill, near Matadi, on the Congo, of Mr. E. J. Glave, the African explorer.

WILLIAM C. WILLIAMSON, LL.D., F. R. S., emeritus professor of botany in Owens College, Manchester, died at London on June 23rd, at the age of seventy-eight years.

UNIVERSITY AND EDUCATIONAL NEWS.

HARVARD UNIVERSITY has this year awarded 664 degrees distributed as follows: A. B., 363; S. B., 24; M. D. V., 10; D. D. M., 17; M. D., 65; LL. B., 76; D. B., 6; A. M., 85; Ph. D., 16; S. D., 3.

AT a meeting of the board of trustees of Cornell University, June 20th, the following assistant and associate professors were promoted to full professorships: H. S. Gage, anatomy, histology and embryology; E. B. Titchener, psychology; J. E. Creighton, logic and metaphysics; G. W. Jones, mathematics; R. C. Carpenter, experimental engineering; C. L. Crandall, civil engineering; W. F. Durand, marine engineering; H. J. Ryan, electrical engineering. John H. Barr was made associate professor of machine design.

TO meet the needs of the recent reorganization of Columbian University, it is proposed to collect \$75,000 to be expended at the rate of \$15,000 a year. Of this amount \$27,500 has been subscribed, including \$5,000 each from Gardiner G. Hubbard, Eugene Levering and S. W. Woodward.

THE graduating class of Cornell University contained 363 students. The A. M. degree was conferred on 33 candidates, Sc. D. on 6 candidates and Ph. D. on 13 candidates.

AT the commencement exercises of Smith

College, on June 18th, it was announced that two sums of \$5,000 each had been given to the college by donors whose names were withheld.

AT Amherst State College L. S. Metcalf has been appointed professor of mathematics, physics and engineering and G. E. Stone professor of botany.

UNION COLLEGE celebrated the one hundredth anniversary of its foundation on June 28th.

AT Williams College George A. Hunter has been appointed assistant in biology and Willis J. Milham instructor in physics.

MRS. JULIA A. IRVINE, who for a year has been acting president of Wellesley College, has accepted the office of president. The degree Litt. D. has been conferred on Mrs. Irvine by Brown University.

DR. V. KRIES, of Freiburg, has been appointed to the chair of physiology in the University of Leipzig, vacant by the death of Ludwig.

DR. NIETZKI has been appointed full professor in the University of Basel, and Dr. N. U. Assing has accepted the professorship of mineralogy in the University of Copenhagen.

DR. ERNST MACH, now professor of physics in the University of Prague, has accepted (according to *The Open Court*) a professorship of the history and theory of inductive science in the University of Vienna.

DR. M. ESCHENHAGEN, in charge of the Royal Magnetic Observatory at Potsdam, has been promoted to a professorship.

CORRESPONDENCE.

TOPOGRAPHIC METHODS.

GENERALLY speaking, sketched details of topography will compose the largest part of a map, and the question arises: How are such interpolations best made to produce accurate as well as uniform and artistic results?

The expert topographer, intuitively, separates minor features of the surrounding terrene from those accidents of the ground which characterize forms that may not only be represented in the scale of the map, but which will also materially assist in delineating and representing the general system that may condition such forms. Where the general configuration or surface-modeling conforms to an easily recognizable system, a broader interpretation and a more free treatment of the terrene should be observed than in the case of an area showing diversified forms and having an irregular relief.

Topographic sketching in this sense not only requires artistic sensibilities, but it also demands a correct and comprehensive interpretation of forms, under a supposition which is at variance with the facts, inasmuch as the map is drawn as if the terrene were seen from a point at infinite distance.

The question now arises: How is the young topographer to be best prepared in order to meet the requirements with general satisfaction?

My views fully coincide with those of Professor Davis, given in a recent note in SCIENCE, that 'a very careful and sympathetic study of the origin of land forms on the ground before the topographer' will enable him to 'make less mistakes of interpretation' than one whose principal aim is to give mathematically correct locations without possessing any knowledge of either terrene forms or the agencies which produced them.

Mathematical knowledge in surveying is, of course, a *sine qua non*, but the study of terrestrial relief and the orthogonal projection of the latter into horizontal plan should be made a careful study, and to this the young topographer's attention should be principally directed, guarding him, however, against falling into that error which a thorough familiarity with structural geology and a knowledge of its originating causes are

apt to commit, namely, never to represent on the chart imaginary forms of topographical elements that are not visible from the occupied stations in the field. In other words, the topographer should not, on the strength of a familiarity with structural geology, attempt to sketch the contours on the further (invisible) slopes of hills merely by inference, or, because the contours delineating the visible slopes before his eyes may be well determined, and, in a measure, may suggest the probable shape of the further sides.

I believe with Professor Davis, that "the best course of education for topographers, while yet in school, should include a careful study of the development of land forms," which may be done in various ways.

A 'comparative' study of relief-models with two sets of topographic maps (all on a large scale) of the same area—one set with hill-shading and the other with horizontal equidistant contours—together with a series of panoramic views, covering the same area and taken with a surveying camera, would probably give the student not only excellent means for comparing the 'representative force' of the various conventional methods of indicating topographic forms, but an intelligent comparison of the maps and model with the photographs (or with nature) would train the young topographer into seeing the facts, and he would thus make a good start towards acquiring facility in sketching topographic forms of the terrene spread out before him.

A course of 'iconometric' platting, on a large scale, from photographic perspectives (metro-photography), would also offer an excellent opportunity, not only to demonstrate how the elements selected as characteristic points in the landscape are interpreted or transposed into horizontal plan, but such a course would also offer the student the means to clear any doubt he may have regarding the transposed forms of

features before his eyes, by constructing the orthogonal projection of such features, graphically, in a simple manner, from their perspective views.

J. A. FLEMER.

WASHINGTON, D. C.

THE METEOROLOGICAL AND MAGNETICAL OBSERVATORY ZI-KA-WEI, NEAR SHANGHAI, CHINA.

THE Zi-ka-wei Observatory, founded in 1873 by the French Roman Catholic Mission of Kiang-nan, has been provided by the same with all the instruments necessary for the study of meteorology and terrestrial magnetism, and from that time it has not ceased to pursue actively the study of those two branches of science. The work of the Observatory comprises 3 parts :

(1) The first part is a public service accepted out of good will ; and it may be said gratuitously, in behalf of the port of Shanghai. This manifold service includes : the service of the time-ball by which the exact time is given to the port of Shanghai by the fall of a meridian ball ; a daily bulletin, posted up at Shanghai, contains information on the weather at Shanghai and along the coast of China ; the typhoon and storm warnings by means of signals hoisted up at a semaphore. (2) The second part of our work is composed of hourly meteorological and magnetical observations published in monthly bulletins, which make at the end of each year a volume in-4to of over 200 pages. (3) The third part comprises special studies on meteorological or magnetical subjects, the whole of which comprises already 26 memoirs.

But up to the present the study of astronomy has been altogether left aside. When the service of the time-ball was inaugurated at Shanghai, twelve years ago, by the care of the Municipal Council of the French Settlement, the Observatory received, at the expenses of that Council, a little transit in-

strument, good for the determination of the time, but altogether inadequate to astronomical observations properly so called. This absence of instruments fit for astronomical studies we have seen it regretted by many learned men. To quote but one only, Mr. A. Tissandier, relating in *La Nature No. 944* his visit to the Zi-ka-wei Observatory, expressed his regret of seeing us neglecting astronomy. Our too limited staff had prevented us till now, just as much as the lack of pecuniary means, to think seriously about giving to our Observatory a so-eagerly-longed-for development. At present we would be in a better condition even to undertake a series of studies in that so interesting branch of science. But it is quite impossible that the Catholic Mission, which has made so many expenses to found the Observatory and maintain it in its present state, make to itself the expenses for such an establishment. It is even impossible that it can suffice for the cost of the instrument which we wish to set up in the first place, *i. e.*, an equatorial telescope of becoming size. We must then necessarily have recourse to the generosity of those interested in the advance of science and particularly in the studies made at Zi-ka-wei. The city of Shanghai profiting above all by our work, it was then quite natural that we first of all address ourselves to it. And that we have done in demanding from the two Settlements (English and French) to be so kind as to contribute each for a sum of £400 to the setting up of an equatorial telescope at the Zi-ka-wei Observatory. That proposal, brought before the meeting of the Ratepayers of the English Settlement on the 12th March by Mr. G. J. Morrison and seconded by Mr. J. Henningsen, has been received with the marks of the greatest sympathy and voted unanimously.

A similar reception of my demand has been made at the meeting of the French

Municipal Council on the 1st of April, and the Council granted likewise a sum of £400 to the Observatory for the same end. Besides, the shipping companies established at Shanghai have promised to subscribe for the same purpose a sum, the amount of which their agents have not been able to fix immediately, but the sum total may, perhaps, be equivalent to £400. But this sum of £1,200 will be very little for an equatorial telescope of convenient size, for instance of an aperture of 20 inches; very little especially for a complete astronomical observatory.

I have made up my mind to address myself to all those to whom the Lord has distributed, together with fortune, the love of science and the desire of utilizing for its advance the fortune they possess. It is to them to whom I make application, begging them to be so kind as to contribute, according to the pecuniary means they may dispose of, to that development of the Zi-ka-wei Observatory. I am aware that to solicit thus of the public a subscription in favor of a private institution, it would be necessary to be able to present simultaneously titles to the benevolence and guarantees that the solicited money will be usefully employed for the proposed end. But the Zi-ka-wei Observatory can present, I believe, both. Its titles to the benevolence it is its past, and its work of which I have spoken about above; titles which, as it has been seen, are far from being denied by the community of Shanghai. The said work constitutes also, I presume, the best guarantee that the asked-for money will be usefully employed. My claim, being founded on these considerations, I dare hope that my request will be received kindly and that numerous benefactors will be willing to help us to succeed in this useful undertaking.

STANISLAS CHEVALIER S. J.

Director of the Observatory.

ZI-KA-WEI, near Shanghai, 8 April, 1895.

SCIENTIFIC LITERATURE.

The Royal Natural History. Edited by RICHARD LYDEKKER. Vol. III., pp 596. Royal 8°. 1894-1895; Frederick Warne & Co., London and New York.

Volume III. of this important work has just reached America. The first half is devoted to Mammals; the second to Birds. The groups of Mammals treated are the Cetaceans, Rodents, Edentates, Marsupials and Monotremes, thus concluding the class. One hundred and thirty-six pages are given to the Rodentia—the most difficult order of all. That this chapter is the best popular account of the group yet written goes without saying, though in numerous details it is sadly behind the present state of knowledge, particularly with reference to American forms.

In describing the molar teeth of rodents the author forgot the *Geomysidæ* and *Aploodontia* when he said: 'permanently-growing rootless molars *always* have complex crowns.' But he made a happy comparison, and one easily remembered, respecting the parallelism between the molar teeth of rodents and of the mastodons and elephants, "the molar tooth of a mouse, which has distinct roots and a low crown with simple cusps, being exactly comparable to that of a mastodon; whereas the high crowned laminated and rootless molar of a guinea pig corresponds as closely with that of a modern elephant."

In describing the coloration of the group as a whole he says that no rodent has 'the tail ornamented with alternate light and dark rings,' forgetting the handsome Mexican ring-tailed ground squirrel (*Spermophilus annulatus*) described by Audubon and Bachman half a century ago.

His ideas of the American chipmunks are hopelessly mixed. He says that southern specimens of the common eastern *Tamias striatus* are 'lighter in color than those from the north.' The reverse is the case. In the same paragraph a California species is

mentioned under the name *T. macrotus*—an animal unknown to American mammalogists, and it may be added that no representative of the eastern chipmunk occurs in western America. Then, turning to the western chipmunks, which he regards as varieties of the Siberian *T. asiaticus*, he says: "The Siberian chipmunk ranges in North America from Lake Superior and the neighborhood of the Barren Grounds to New Mexico and Arizona, and extends from the Atlantic to the Pacific seaboard." This is a mistake, as no member of the group in question approaches the eastern States; and if Mr. Lydekker could see a dozen of our American species (without reference to the subspecies) I am sure he would never again think of them as 'varieties' of the Siberian animal.

The ground squirrels of the genus *Spermophilus* (which by the way is antedated by *Anisonyx*, as already pointed out in this journal, SCIENCE, I., 1, Jan. 4, 1895, p. 18), are said to 'have very nearly the same distribution as the chipmunks.' But in America considerably more than half of the numerous species are desert animals, living where chipmunks never go. It is also stated that nearly all the American species have long tails, whereas more than half of them have short tails.

Our 'prairie dogs' (*Cynomys*) are called 'prairie marmots,' a much better name, but one it would be exceeding difficult to bring into general use. Only three species are recognized (instead of four), the two of the Rocky Mountain plateau (*gunnisoni* and *leucurus*) being confounded under a name belonging to neither, namely, *C. columbianus*. This name, as shown several years ago, belongs to a ground squirrel or suslik inhabiting northern Idaho and parts of Canada.* The distribution given for this imaginary animal (made up of two genera and three species) is equally remarkable, for it is said to range from the 'Columbia through Colo-

rado and Arizona to the Sierra Nevada.' No species of the genus *Cynomys* occurs anywhere in the Columbia region, or in the Great Basin; and no species comes nearer than about 400 miles of the Sierra Nevada. The account of the habits quoted from Lewis and Clark relates exclusively to the northern suslik (*Anisonyx columbianus*).

In the case of the true marmots (*Arctomys*), as in the prairie marmots, only 3 species instead of 4 are recognized—the Rocky Mountain and Sierra-Cascade species being confounded under the name *flaviventer*. The name given for the Arctic-Alpine hoary marmot, *pruinosis*, is antedated by *caligatus*.

The jumping mouse (*Zapus*) is said to range from Great Slave Lake and Hudson's Bay to Arizona and Mexico. It has been found in the mountains of Colorado, but I am not aware of a record for Arizona or Mexico.

The American white-footed mice, of which there are several genera, are all lumped with the European Hamsters in the genus *Cricetus*.

Our wood rats (*Neotoma*), of which about 25 species are known, are spoken of as 'a small genus!' The lemmings, singularly enough, are interposed between the voles (*Microtus*) and muskrat (*Fiber*). Had Mr. Lydekker compared the skull of *Fiber* with that of *Microtus amphibius* it is doubtful if he would have recognized it even as a subgenus.

In characterizing the family of pocket gophers (*Geomysidae*) the same mistake made in *Flower and Lydekker's Introduction to the Study of Mammals* is repeated, namely, the supposed anterior extension of the cheek bone of jugal. Some remarkable things are said concerning the burrows of these animals.

The 'common Kangaroo rat,' "which inhabits the desert regions to the eastward of the Rocky Mountains," is said to be *Dipodomys phillipsi*. This is perpetuating an old

* N. Am. Fauna, No. 5, July, 1891, pp. 39-42.

error. *Dipodomys phillipsi* does not occur in the United States at all, but in southern Mexico, as pointed out long ago by the reviewer; the only members of the group inhabiting the plains east of the Rocky Mountains belong to the allied genus *Perodipus*. We are told that "Probably the only water these creatures drink is that derived from dew collected on the cactuses." The author may be surprised to hear that dew does not form in the American deserts where Kangaroo rats live, and that these animals, like most other desert rodents, do not drink.

Maximilian's pocket mouse (*Perognathus fuscicatus*), which, although unmarked, is called 'the banded pocket mouse,' is said to be 'characterized by the hair being coarse and bristly.' On the contrary, the hair is soft and silky; the only species having stiff hairs belong to another subgenus (*Chetodipus*).

Only one pika (*Lagomys*) is credited to North America, though at least three are recognized by American mammalogists.

In describing the habits of rabbits it is stated that all the members of the family, except the European rabbit and the hispid hare of northern India, 'dwell either in open country among grass and other herbage, or among rocks and bushes,' forgetting that the common varying hare (*Lepus americanus*) lives in the dense coniferous forest that stretches across the American continent from Labrador and northern New England to Alaska.

After the lumping that characterizes so much of the book, particularly with respect to American mammals, it is refreshing to find that the author, following Lilljeborg, recognizes the common hare of Europe as a distinct species (under the name *Lepus europæus* Pallas) from the mountain hare (*Lepus timidus* Linn.) of Scandinavia and the higher elevations of Europe.

It is also pleasing to note that the author gives the weight of his high authority to

the view that the Old World pangolins and aard-varks probably do not properly belong among the Edentates. The name of the great anteater will probably have to be changed from *Myrmecophaga jubata* to *M. tridactyla*, the latter being used by Linnæus in the 10th edition of the *Systema Naturæ*, 1758. The chapter on the Edentates is of special importance, as are those on the Cetaceans, Marsupials and Monotremes.

An important and in every way praiseworthy feature of the work is the brief notice of extinct forms given at the end of each chapter. These, coming from a man of Lydekker's rank as a paleontologist, may be taken as authoritative summaries of the present state of knowledge of fossil mammalia.

Curious liberties have been taken, intentionally or otherwise, in the spelling of generic and specific names, as *Rhithrodontomys* for *Reithrodontomys*, *Haplondon* for *Applodontia*, *Speotito* for *Speotyto*, *capybara* for *capybara*, *husdonianus* for *hudsonicus*, and so on. By an unfortunate slip some quotations from the well-known naturalist, J. A. Allen, are attributed to the California bird collector, C. A. Allen.

The illustrations, most of which are from Brehm, as explained in the previous review, cannot always be taken as correct likenesses. For instance, the 'common chipmunk,' on page 78, looks like Say's ground squirrel with the tail of a mongoose; and in the picture of prairie dogs, or prairie marmots, on page 82, the two large animals are certainly not *Cynomys*, but *Arctomys*, and the smaller ones might be anything. The muskrat and pika also are very unlike the animals they are intended to represent.

The work as a whole, while designed for a popular audience and bearing marks of hasty preparation, is nevertheless of much value to professional naturalists, particularly the chapters treating of groups that have been personally studied by the author

—as the Cetaceans, Edentates and their allies, and others. While it has been deemed useful, especially in an American review, to point out the most conspicuous errors in the treatment of the American members of the perplexing order Rodentia, it must not be supposed that other parts of the book are equally open to criticism. In reviews it is both proper and desirable to point out erroneous statements, while, from the nature of the case, like detailed comment respecting the good qualities is well nigh impossible. Hence notices of very good books often seem to consist mainly of adverse criticism. I fear this is true in the present instance.

The bird part of the Royal Natural History will be reviewed separately.

C. H. M.

Lehrbuch der Biologie der Pflanzen. FRIEDRICH LUDWIG. Stuttgart, Verlag von Ferdinand Enke. 1895. 8°, pp. vi + 604, with 28 figures in the text.

The Germans are quite persistent in refusing to recognize as biology the mixture of botany and zoölogy, which is rather unfortunately called biology by the English and Americans, and as a general thing they designate by the latter name the relations of plants to their surroundings, a subject that the Madison Congress of American botanists agreed to call ecology. It is, therefore, to this subject that Professor Ludwig's latest book refers, and it includes chapters on the adaptations of land and water plants to their surroundings, adaptations to a parasitic habit of life, the part played by fungi in the nutrition of higher plants, carnivorous plants, commensalism and symbiosis, adaptations of plants to the physical and chemical character of the soil, climbing plants, phenology, the various protective devices met with in plants, the many interesting arrangements concerned with pollination and dissemina-

tion, and the influence of man on the forms of plants, with which is connected a general discussion of heredity and the causes of variation from hereditary types.

Dr. Ludwig is an earnest student of the relations of plants to their surroundings, especially of their adaptations to pollination by insect agency, and his book appears to be not only pleasantly written, but accurate in its statement of fact.

WM. TRELEASE.

A Monograph of the North American species of the genus polygonum: By JOHN KUNKEL SMALL. Memoirs from the Department of Botany of Columbia College, Vol. I. Issued April 23, 1895. 4°. pp. 183, Pl. A. and 84. Price \$6.00.

While it is generally believed that the classification and naming of plants is a less advanced branch of botanical investigation than the study of their morphology, development and physiology, botany would be a very crude science, indeed, without such work, and one of the duties that fall to the possessors of every large herbarium is that of monographing difficult groups—a duty all the more imperative because of the undeniable fact that such work can only be done where good library and herbarium facilities are at hand.

The botanical department of Columbia College, with one of the finest herbaria and systematic libraries in the country, is apparently fully aware of this fact, and at frequent intervals Dr. Britton and his assistants and special students publish revisions that are helpful to all systematic students of the North American Flora. The last of these publications inaugurates a series of Memoirs which promise to reflect much credit on the institution under the auspices of which they are published.

No collection in the world contains more valuable material for a study of the North American Knotweeds than is to be found at

Columbia, which possesses the herbarium of Meisner, the last general monographer of the genus, and to this has been added the choicest of the other collections of the country. While Mr. Small has done no small amount of field work on some of the forms, the result appears to be worthy of the facilities he has enjoyed, though, like all monographic essays, its strength or weakness must be tested by practical use. Keys to the sub-genera and to the species under each of these, and plates representing the habit and the more essential details of each species, render the work easy to use, and the anatomy of representatives of the several groups has been comparatively studied and largely illustrated. In appearance the monograph is good, and the plates are clearly drawn and well printed, though a little flat and harsh—a defect that the artist will doubtless overcome in future work.

WM. TRELEASE.

The Geological and Natural History Survey of Minnesota. The Twenty-third Annual Report, for the year 1894. N. H. WINCHELL, State Geologist. Minneapolis, Harrison & Smith, State Printers. 1895. 8vo. 255pp.

This survey has kept steadily on its way for many years, under the able direction of Professor Winchell, who gives us annually a volume in which matters of practical importance to the people of Minnesota and questions of general scientific interest alike find efficient treatment.

In the present volume, after a summary statement of the year's work of the Survey, Professor Winchell, in Part II., discusses the Origin of the Archæan Greenstones of Minnesota. This paper is of the nature of a review of Bulletin No. 62 of the U. S. Geological Survey on the Greenstone Schist areas of the Menomée and Marquette Regions of Michigan, by Dr. George H. Williams, in which the tendency of the conclu-

sions reached by Dr. Williams is to refer the greenstones as a body to dynamic metamorphism of massive eruptive rocks, while a sedimentary origin is not denied to a part of them. Professor Winchell skilfully arranges the facts, both megascopic and microscopic, in support of his own view of the origin of these greenstones, and would reverse the main conclusion of Dr. Williams as to the comparative amounts of the two sorts, massive and sedimentary. His conclusions are given in the following words: "We look upon the greenstones in Minnesota as an oceanic terrane having a definite stratigraphic position (the uppermost part of the Keewatin), although probably involving some truly irruptive masses. Its materials, both basic and acid, are interbedded by sedimentation the one with the other, and are sometimes mingled. The decayed condition of these materials is due to the natural action of the Keewatin ocean prior to consolidation, and the crystalline condition of the lower beds is due to later metamorphism which, having its active forces and seat at greater depths, did not permeate the whole formation. It is not attributable so much to dynamic movements as to internal heat. Wherever such movements operated with much violence, the lower Keewatin sediments were fused, producing irruptive felsytes and granite. Such granite is bordered usually by belts of crystalline schist, evidently formed at the time of such fusion."

Part III. is devoted to a preliminary report on the Rainy Lake Gold Region, by H. V. Winchell and U. S. Grant, in which, after an introductory part on the occurrence and associations of gold ores, and a historical sketch of the gold discoveries of this region, the body of the report is devoted to the general features and geology of the area and a more detailed account of individual properties. Most of the gold-bearing rocks of this district belong to the *Keewatin* di-

vision of the Archæan of the Minnesota Survey, which would correspond with the Upper Algonkian of the U. S. Geological Survey. The gold occurs (1) in segregated veins, (2) in fissure veins and (3) in fahlbands.

The segregated veins seem to resemble in all respects the veins which carry the greater part of the gold in the Appalachian region, at least, from North Carolina to Alabama. The quartz of these veins in lenticular masses is disposed in irregular belts from one to ten or more feet in width, which are roughly parallel with the lamination of the enclosing slates, and it is often the case that the gold is also found in the quartzose rock immediately enveloping the lenses. This agrees well with what has been noticed in the Southern Appalachian fields; and in the prospects of the Rainy Lake area as a gold-producing region there is also a close agreement with what has recently been given out as the conclusion of Prof. Becker regarding the Southern Appalachians, viz., that while the winning of the gold will probably never be of the nature of a bonanza, yet it will, if properly managed, yield a good interest upon the money invested. Apart from the gold-bearing veins, the resources of this region most to be counted upon for future development are (1) the excellent farming lands, (2) the large bodies of good timber, (3) the large water power and (4) the probability of the existence of valuable deposits of iron ore.

Part IV. is a well considered paper by W. R. Hoag, on the Advantages to be Derived from a Topographic Survey of the State. In Part V. Professor Winchell gives a historical sketch of the Discoveries of the Mineral Deposits of the Lake Superior Region, including some interesting details of the prehistoric mining in the copper regions. In this sketch attention is called to the important fact that the majority of the metaliferous belts were discovered by official

geologists in the performance of their assigned duties. Among these discoverers the name of Dr. Douglass Houghton stands preëminent.

Part VI., by Mr. Warren Upham, is in continuation of an investigation published in the preceding report of this survey, and relating to the glacial lakes which are now succeeded by the present great Laurentian lakes. The author brings forward evidence to prove the pre-glacial elevation of North America, the late glacial subsidence, and the reëlevation by a wavelike epeirogenic uplift. The measurement of post-glacial time by the recession of Niagara Falls is also fully discussed, the conclusion reached that the estimate of 7,000 years, made by Gilbert in 1886, accords best with the facts observed. The paper ends with a tabular presentation of the epochs and stages of the glacial period, using the nomenclature proposed by Professor Chamberlin.

The rest of the volume is devoted to notes upon some Minnesota minerals, to chemical analyses, lists of rock samples, etc., without general interest, except some notes by Professor Winchell upon the bedded and banded phases of the gabbro of northeastern Minnesota.

EUGENE A. SMITH.

UNIVERSITY OF ALABAMA.

FOLK-TALES.

Le Folklore Dans Les Deux Mondes. Par LE CONTE H. DE CHARENCEY. Paris, C. Klincksieck. 1894. Pp. 424.

Louisiana Folk-Tales. In French Dialect and English Translation. Collected and Edited by ALCEE FORTIER, D. Lt. Houghton, Mifflin & Co. 1895. Pp. 122.

The work of M. de Charencey forms the twenty-third volume of the 'Actes de la Société Philologique,' a society, by the by, which in its various issues presents a great deal of value on American languages. The author, well known for his numerous and erudite writings, here takes up a series of

myths and folk-tales which are found in tribes and nations widely asunder in time and place, and points out the traits which he believes to be original, and those he considers assignable to contact. The majority of them are either American or represented in America. The longest, 135 pages, is that which he calls 'Lucina sine concubitu,' *i. e.*, the Myth of the Virgin-Mother. As he shows, this is a very common tale repeated with slight variations in the New and Old World. Another of special interest is that of the subterranean origin of the human species, which is connected with the flood-myth and various cosmogonical legends. Other chapters are devoted to 'The Origin of the Sun,' 'Dog-Men,' 'The Myth of Psyche in America,' 'The Discovery of Maize,' 'The Name of the Metals in the Languages of Mexico,' etc.

The learning of the author is everywhere manifest and also his familiarity with original sources and native languages; but to one who believes in the modern anthropologic school of folk-lore his constant effort to trace connection and dependence between myths of distant nations will prove disappointing. He is a firm believer in the fanciful theories about early American culture advanced by the late M. Leonce Angrand, who maintained there were two currents of civilization, one the 'Floridian or eastern Toltecs,' the other the 'western Toltecs'; the former from southern, the latter from central or northern Asia. No tenable arguments support this hypothesis, and its introduction into a work of original research, such as this, is a misfortune.

Professor Fortier's volume is the second of the 'Memoirs of the American Folk-lore Society.' It consists of fourteen animal tales, twelve fairy tales or *märchen*, and an appendix of fourteen short stories in English only. Some brief notes accompany the text, mentioning the source or informant. Most of the tales can readily be traced to

European originals, which have become modified by the local surroundings. The few exceptions to this are possibly African, but the negroes in the United States seem to have lost early and completely both their language and folk-lore. The volume is also valuable for its examples of the true Creole dialect. This is now disappearing, and Professor Fortier found it no easy matter to obtain these narratives, the younger generation knowing nothing of them and the older being desirous of forgetting them.

The translation is generally very satisfactory; though in such renderings as 'alors pove fille la di,' by, 'the young lady said to herself,' greater simplicity would have been preferable.

D. G. BRINTON.

The Second Law of Thermodynamics. PROFESSOR OLIVER J. LODGE, Proceedings, Liverpool Engineering Society, December, 1894, twenty-first session, with discussion.

Professor Lodge, in this discussion, begins with the statement that the Second Law of Thermodynamics asserts that the proportion, range of temperature worked through by a heat engine divided by initial maximum, absolute temperature, represents the largest proportion of the heat present in the working substance in any cycle of thermodynamic action which can be, by any means, converted from the thermal form of energy to the mechanical or dynamic, and proceeds to show that "the second law of thermodynamics is, after all, nothing more than enlightened common sense." The deduction is immediate and obvious that the higher the temperature the greater the availability of the heat, and the larger the proportion which may be converted into the other form of energy in any thermodynamic cycle. The drop of temperature between firebox and boiler, for example, means an absolute loss of availability of heat, in the

proportion of the difference between the final range between the boiler and atmosphere or other lower limit of temperature and the range between the firebox temperature and the same lower limit. If the absolute furnace temperature is 2000° C., boiler temperature 500° C., and condenser temperature 350° , for example, the availability of the heat generated by combustion is reduced at the first step from $(2000-350)/2000 = 0.825$ to $(500-350)/500 = 0.30$; even though the most perfect of thermodynamic engines is employed.

"But though the second law is scientifically precise and incontrovertible, it is hard at first to realize how and why it can be true that the temperature which exists in bodies so entirely controls its availability or working power." This the author proceeds to explain by reference to illustrations in other fields of energetics. The deduction follows:

"The transferable portion of heat is to the whole heat as the available difference of temperature is to the whole temperature above absolute zero. Hence the efficiency of transfer is equal to the ratio of the available difference of temperature to the maximum absolute temperature."

This is Professor Lodge's enunciation of the second law of thermodynamics. It follows that "A working substance above average pressure has some available mechanical energy; a working substance below average temperature has some available thermal energy, but a substance at average pressure and temperature has no available energy."

"The second law of thermodynamics relates to the utilization of heat energy as heat, *i. e.*, as irregular and uncontrollable molecular motion. If, by any means, molecular motion could be taken under control, it would cease to be heat—the second law of thermodynamics would not apply to it—and a much greater portion of its energy

might become available." Thus "Animals do not turn their food energy into heat, but utilize it direct. They are not heat engines. If they were, they would be miserably inefficient because of their low temperature; but they are chemical engines, analogous to the electric battery and are marvellously efficient."

A working substance, for use in any heat engine, must have the following qualifications to insure efficiency:

1. It must have great capacity for heat.
2. It must be able to sustain high temperature.

By utilizing the whole difference of temperature between the furnace and the surrounding bodies, any heat engine, as, for example, the gas engine, is seen to involve, according to the laws of thermodynamics, a possibility of raising the efficiency of the heat engine, "not five or six per cent., which is almost all the present difference between the best steam engines and the worst, but to a revolutionary change of fifty or sixty per cent; no drop of temperature being permitted from furnace to everyday temperature, without delivering up its due equivalent of motive power."

R. H. T.

SOCIETIES AND ACADEMIES.

ALABAMA INDUSTRIAL AND SCIENTIFIC SOCIETY.

THE annual meeting of this Society was held in Birmingham on the 8th instant. The officers elected for the ensuing year are Mr. Thomas Seddon, President, and Messrs. E. A. Uehling and C. E. Bowron, Vice-Presidents; Messrs. Eugene A. Smith and Henry McCalley were continued as Secretary and Treasurer respectively. The retiring President, Dr. Wm. B. Phillips, in his address before the Society, gave some particulars of the experiments conducted by him in Bessemer for the concentration of the Red Mountain (Clinton) ores. This

concentration is effected by making the ore magnetic by roasting in a suitable furnace in contact with producer gas, then after crushing to small size passing it over a magnetic separator, when the silica is thrown off and the iron ore remains to fall into a bin. The experiments have been carried far enough to demonstrate the fact that concentration may be carried out which will make available the stratum of ore hitherto thrown aside as too high in silica for profitable working. The carrying out of this process on a commercial scale would mean a great deal for the Birmingham district.

The subject set for discussion at this meeting was the utilization of the by-products of the coking ovens, and on this Mr. A. J. Montgomery read a paper of much interest. The next meeting of the Society will be held in the autumn.

EUGENE A. SMITH,
Secretary.

ST. LOUIS ACADEMY OF SCIENCE.

THE Academy held its regular meeting on June 17th, with President Green in the chair and 25 members and visitors present.

Dr. C. R. Sanger spoke of the Chemistry of Photography, dividing his discourse into the following headings: (1) The Formation of the Latent Image. (2) The Development of the Latent Image. (3) The Fixation of the Developed Image. (4) The Printing of the Positive. (5) The Toning of the Positive.

Adjourned until the third Monday in October.

A. W. DOUGLAS,
Recording Secretary.

SCIENTIFIC JOURNALS.

THE AMERICAN JOURNAL OF SCIENCE.

THE July number of the *American Journal of Science* commences the fiftieth and closing volume of the *third* series; it is the one hundred and fiftieth volume since the Jour-

nal was established in 1818. The opening article is by Frank Leverett, on the Correlation of New York moraines with raised beaches of Lake Erie. The investigation here detailed is in continuation of the work earlier done by the same author (the results published in 1892) in tracing the connection between the raised beaches of the western portion of the Erie basin and certain moraines in Ohio. It is a department in which G. K. Gilbert had also made extensive investigations previous to this time, notably in 1886. The names given to the successive beaches are those suggested by Mr. Gilbert, viz., the upper or Sheridan Beach, traced by Gilbert from Cleveland eastward to Sheridan, N. Y., which may be a continuation of the western Belmore Beach and the lower Crittenden Beach, especially investigated to the eastward near Hamburg. A map is given by Leverett, of the region under discussion, showing the position of the beaches and the moraines and other related features exhaustively treated in this article. The author reaches some important conclusions, which, however, hardly admit of brief statement; one point made relates to the successive outlets of the lake during the glacial times. A paper by H. L. Wells describes, as a continuation of former work in a similar subject, two remarkable chemical compounds containing lead and extra iodine. These are Johnson's salt for which the formula $5\text{Pb}(\text{CH}_3\text{CO}_2)_2 \cdot 3\text{KI} \cdot 6\text{I}$ or perhaps $5\text{Pb}(\text{CH}_3\text{CO}_2)_2 \cdot 3\text{KI}_3$ is deduced and Gröger's salt with the formula $\text{PbI}_2 \cdot \text{PbO} \cdot 3\text{I} \cdot \text{H}_2\text{O}$.

Two papers on analytical chemistry come from the laboratory of F. A. Gooch, the first embodying the results of work by himself and Charlotte Fairbanks in the estimation of the halogens in mixed silver salts, and the second with C. F. Clemons on the determination of selenious acid by potassium permanganate. S. F. Peckham, in a paper upon the Pitch lake of Trinidad, de-

tails the results of a visit to that remarkable spot in the spring of 1895. In this connection he gives an interesting review of early descriptions of the same region, commencing with that of Anderson in 1789, also Nugent in 1807, Alexander in 1832, Manross in 1855 and others later. The paper is accompanied by several sketch maps which give definiteness to the description. J. C. Merriam describes some reptilian remains from the Triassic of northern California, of much interest in view of the fact that the Mesozoic of California has thus far yielded so little in this direction. The remains studied represent two individuals from the black Triassic limestone of Shasta county. The first, consisting of eight vertebrae, some fragments of ribs and both coracoids, receives the same *Shastasaurus pacificus*. In the second, the remains consisted of some twenty-five vertebrae, mostly anterior caudals; these resemble those of *Ichthyosaurus*, but in certain particulars, as in an ungrooved single-headed rib, it agrees rather with the new genus established, *Shastasaurus*. The material, however, was insufficient for specific characterization. The concluding article of the number is a discussion by Frank D. Adams, of the Laurentian of Canada, accompanied by two plates. The region, the study of which has yielded the results here concisely presented, is shown in Plate I. It lies to the north and west of Montreal and the St. Lawrence river, and is largely occupied by the crystalline schists of the Grenville Series with subordinate masses of the "Fundamental Gneiss" and a number of anorthosite intrusions. The stratigraphy and petrography are both discussed, and the latter is supplemented by a series of analyses of typical gneisses and slates. The author concludes that in the district under consideration there are "at least two distinct sets of foliated rocks. One of these, comprising limestone, quartzites and certain garnetiferous or sillimanite gneisses,

represents in all probability highly altered and extremely ancient sediments. The other set intimately associated with these are of igneous origin, and comprise numerous and very extensive intrusions, both acid and basic in character, which were probably injected at widely separated times." * * * * "The Grenville Series therefore comprises certain primeval sediments which have been deeply buried, invaded by great masses of igneous rocks and re-crystallized. They may, perhaps, in some cases have been mingled with these igneous masses by actual fusion. The whole complex has also been subjected to great dynamic movements. In this way has resulted a series of rocks whose original character cannot in all cases be deciphered, but which can be recognized as being of composite origin, the sedimentary portion representing extremely old, if not the oldest, sediments with which we are acquainted."

AMERICAN CHEMICAL JOURNAL.

THE number for June contains a number of short contributions from various laboratories, and several reports. Gomberg contributes an article on the action of inorganic cyanides on chlorocaffeine. He found that when chlorocaffeine was treated with potassium cyanide he obtained neither the cyancaffeine nor the amidocaffeine, as he expected, but caffeine carboxylamide. The cyancaffeine is produced in the reaction, but only as an intermediate product, being converted, by saponification, into caffeine carboxylamide. The reaction can be represented thus:

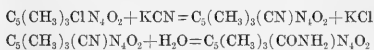

By the action of phosphorus pentachloride on this compound one molecule of water is removed and cyanocaffeine is formed.

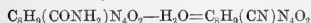

This was found to be the best method for the formation of cyanocaffeine, for all at-

tempts to replace the chlorine by the cyanogen group by treatment with potassium cyanide under various conditions were only partially successful. The acid amide was converted into caffeine carboxylic acid and a number of salts were prepared and studied. All the compounds could be explained by the accepted structure for caffeine.

Shober and Kiefer describe the results of a series of experiments on the decomposition of metadiabenzene sulphonic acid. They find that this acid when boiled with methyl, ethyl and propyl alcohols, at different pressures, gives both the methoxy and hydrogen reaction, while the corresponding para compound gives only the hydrogen reaction. Kastle and Keiser have a paper on the colorimetric determination of the affinity of acids by means of potassium dichromate. The reaction depends upon the fact that when a solution of potassium dichromate is treated with a solution of sodium acetate or the sodium salt of other acids, the base is equally distributed and the normal chromates are formed. They used as a standard a solution of potassium dichromate to which a solution of tenth-normal sodium hydroxide was added until an equal color was obtained. They could determine the amount of decomposition and, assuming the affinity of potassium dichromate as 1, could calculate the relative affinities of the acids. For many of the acids the results agree fairly well with those obtained by Ostwald; but for some acids the method could not be used. Mixer gives the methods of preparation and properties of some azo and azimido compounds, and Noyes contributes another article on camphoric acid. He finds that in the formation of campholytic acid, from di-hydroamino-campholytic acid, by the action of nitrous acid, another acid is formed, whose reactions, along with other facts, furnish strong proof that the carboxyl groups of camphoric

acid are combined with adjacent carbon atoms. He considers the two isomeric campholytic acids to be stereoisomeric.

An article by Wheeler contains a description of benzimidomethyl ether and its action on aromatic ortho compounds. No new compounds were obtained, as the reactions took place differently from what he expected.

Curtiss has repeated some of Nef's work on the action of ethyl iodide on silver acetyl-acetone



and explains the formation of two products by the assumption that the molecule has two points about equally susceptible of attack, namely, the silver atom and the double bond between the two carbon atoms. The ethyl, therefore, replaces the silver directly, or the ethyl iodide is added to the doubly bound carbonatom. He has also shown that Claisen's objection to Nef's statement, that oxymethylene compounds and acetacetic ether, in the free state, show close analogy, does not hold, as he has obtained an ester by the action of dry hydrochloric acid gas on acetacetic ether in alcohol. Randall contributes a report of articles by Ramsay on 'The molecular complexity of liquids.' This number also contains obituary notices of James A. Dana, Lothar Meyer and Gerhard Krüss.

J. ELLIOTT GILPIN.

NEW BOOKS.

- Fingerprint Directories.* FRANCIS GALTON. London and New York, Macmillan & Co. 1895. Pp. 123. \$2.00.
- Annual Report of the Department of Health of the City of Chicago.* ARTHUR R. REYNOLDS. Chicago. 1895. Pp. lix+268.
- A Text Book of Physiology.* M. FOSTER. New York and London, Macmillan & Co. 1895. Pp. xlvi+1183. \$5.00.

SCIENCE

NEW SERIES.
VOL. II. No. 28.

FRIDAY, JULY 12, 1895.

SINGLE COPIES, 15 CTS.
ANNUAL SUBSCRIPTION, \$5.00.

GUSTAV E. STECHERT'S

Recent Importation of Scientific Books.

BEBBER, DR. W. J. von. Hygienische Meteorologie. Für Aerzte und Naturforscher. Mit 42 in den Text gedruckten Abbildungen. 8°. M. 8.

BERGH, DR. R. S. Vorlesungen über allgemeine Embryologie. Mit 126 Figuren im Text. 289 Seiten. Gross 8°. M. 7.

DAMMER, DR. O. Handbuch der chemischen Technologie. Unter Mitwirkung von Th. Beckert, Dr. Bender, Dr. Benedict, Dr. Börnstein, u. A. Band I. Mit 191 in den Text gedruckten Figuren. gr. 8°. M. 24.

HANDWÖRTERBUCH DER ASTRONOMIE, Unter Mitwirkung mehrerer Professoren, herausgegeben von Prof. Dr. W. Valentiner. Mit Abbildungen. Lieferung 1. 128 Seiten. Gross 8°. M. 3.60.

HARTLEBEN'S statistische Tabelle über alle Staaten der Erde. Uebersichtliche Zusammenstellung von Regierungsform, Staatsoberhaupt, Thronfolger, Flächeninhalt, absoluter und relativer Bevölkerung, Staatsfinanzen, Handelsflotte, Handel, Eisenbahnen, Telegraphen, Zahl der Postämter, Werth der Landesmünzen in deutschen Reichsmark, Gewichten, Längen und Flächenmassen, Hohlmassen, Armee, etc. M. 50 Pf.

VON JONSTORFF, HANNS FREIHERR JÜPTNER. Fortschritte im Eisenhütten-Laboratorium in den letzten 10 Jahren. Erster Band. Mit 99 Figuren. 270 Seiten. 8°. M. 8.50.

KOLBE, BRUNO. Einführung in die Electricitätslehre. Band II. Dynamische Electricität. Mit 75 in den Text gedruckten Holzschnitten. 187 Seiten. 8°. M. 3.

KRÄMER, INGENIEUR JOS. Wirkungsgrade und Kosten elektrischer und mechanischer Kraft-Transmissionen. Mit vielen Figuren, Schemas und einer Tafel. 88 Seiten. 8°. M. 3.

LEDUC, A. Manipulations de Physique Avec. 144 figures intercalées dans le texte. 392 pages. 8°. Fr. 6.

MEISSNER, G. Die Hydraulik und die hydraulischen Motoren. Ein Handbuch für Ingenieure, Fabrikanten und Constructeure. Zum Gebrauche für technische Lehranstalten sowie ganz besonders zum Selbstunterricht. Zweite vollständig neu bearbeitete Auflage von Dr. H. Hederich und Ingenieur Nowak. I. Band. Die Hydraulik. Lieferung 1. 80 Seiten. 8°. M. 3.

MEYER, PROF. DR. ARTHUR. Untersuchungen über die Stärkekörner. Wesen und Lebensgeschichte der Stärkekörner der höheren Pflanzen. Mit 9 Tafeln und 99 in den Text gedruckten Abbildungen. 320 Seiten. Gross 8°. M. 20.

METZGER, PROF. DR. A., und **PROF. DR. N. I. C. MÜLLER,** Die Nonnenraupe und ihre Bakterien Untersuchungen ausgeführt in den zoologischen und botanischen Instituten der Königl. preuss. Forstakademie Mülden. Mit 45 of Tafeln in Farbendruck-160 Seiten. 8°. M. 16.

MICHAUT, L. ET M. GILLET. Leçons élémentaires de télégraphie électrique. Système Morse-Manipulation-Notions de Physique et de Chimie-Piles-Appareils et accessoires installation des postes. 2^e édition, entièrement refondue. 332 pages. Pet. 8°. Fr. 3.75.

NIWENGLAWSKI, PROF. B. Cours de Géométrie Analytique a l'usage des élèves de la classe de mathématiques spéciales et des candidats aux écoles du gouvernement. Tome II. Construction des Courbes planes. Compléments relatifs aux coniques. 292 pages. 8°. Fr. 8.

PASCH, ADOLF AND HUGO WIETZ. Die elektrotechnischen Maasse. Lehrbuch zum Selbststudium. Dargestellt und durch zahlreiche Beispiele und 38 in den Text gedruckte Figuren erläutert. 153 Seiten. 8°. M. 3.00.

SCHMIDT, DR. F. W. Kurzes Lehrbuch der anorganischen Chemie. Ein Repetitorium für Chemiker, Mediciner und Pharmaceuten. 376 Seiten. 8°. M. 4.50.

VERWORN, DR. MAX. Allgemeine Physiologie. Ein Grundriss der Lehre vom Leben. Mit 270 Abbildungen. 584 Seiten. gr. 8°. M. 15.

WASIMANN, E. Kritisches Verzeichniss der Myrmekophilen und Termitophilen Arthropoden. Mit Angabe der Lebensweise und mit Beschreibung neuer Arten. 231 Seiten. gr. 8°. M. 12.

WINDRATH, DR. A. Die Medicin unter der Herrschaft des bacteriologischen Systems. 231 Seiten. 8°. M. 5.

WYSS, DR. HANS, V. Kurzes Lehrbuch der Toxicologie für Studierende der Medicin und praktische Aerzte. 212 Seiten. gr. 8°. M. 5.

WISLICENUS, PROF. DR. WALTER F. Astronomische Chronologie. Ein Hilfsbuch für Historiker, Archäologen und Astronomen. 163 Seiten. 8°. Leinwandband. M. 5.

ZICKLER, PROF. KARL. Das Universal-Elektrodynamometer. Mit 8 in den Text gedruckten Figuren. 32 Seiten 8°. M. 1.

GUSTAV E. STECHERT,
810 Broadway, New York.

Macmillan & Co.'s New Publications.

Columbia College Contributions to Philosophy, Psychology and Education, Vol. I., No. 4.

Friedrich Eduard Beneke, The Man and His Philosophy. An Introductory Study. By FRANCIS BURKE BRANDT, Ph. D., sometime University Fellow in Philosophy in Columbia College. 8vo, paper cover, pp. 167, \$1.00 net.

Cambridge Natural Science Manuals.

General Editor—A. E. SHIPLEY, M. A., Fellow and Tutor of Christ's College.

New Volumes.

- I. **Elements of Botany.** By F. DARWIN, M. A., F. R. S., Fellow of Christ's College, Cambridge, and Reader of Botany in the University. With numerous illustrations. 12mo, \$1.60 net. (*Biological Science.*)
- II. **Petrology for Students.** By A. HARKER, M. A., F. G. S., Fellow of St. John's College, Cambridge University Demonstrator in Petrology. 13mo, \$2.00.
- III. **A Text-Book of Zoogeography.** By FRANK E. BEDDARD, M. A. (Oxon.), F. R. S., Prosector of the Zoological Society of London. Maps, 12mo, cloth, \$1.60, net. (*Biological Science.*)

The Theory of Light.

By THOMAS PRESTON, M. A. (Dub.), Fellow of the Royal Society of Ireland and Professor of Natural Philosophy, University College, Dublin. 8vo, cloth, pp. xvii-573, \$5.00, net.

Analytical Chemistry.

By N. MENSCHUTKIN, Professor of the University of St. Petersburg. Translated from the third German Edition under the supervision of the Author. By JAMES LOCKE, Assistant in the Analytical Laboratory of the University of Heidelberg. pp. xii-512, 8vo, cloth, \$4.00, net.

Text-Book of Operative Surgery.

By DR. THEODOR KOCHER, Professor of Surgery and Director of the Surgical Clinic in the University of Bern. Translated with the Special Authority of the Author from the Second Revised and Enlarged German Edition by HAROLD J. STILES, M. B., F. R. C. S., Edin., Senior Demonstrator of Surgery and formerly Demonstrator of Anatomy in the University of Edinburgh, etc. With 185 Illustrations. 8vo, cloth, pp. 303, \$3.50, net.

On Certain Phenomena belonging to the Close of the Last Geological Period, and on their Bearing upon the Tradition of the Flood.

By JOSEPH PRESTWICH, D. C. L. (Oxon.), F. R. S., F. G. S., Corr. Inst. France (Acad. Sc.), Acad. R. Lyncei, Rome; Roy. Acad. Brussels, etc. 8vo, cloth, pp. 87, \$1.00.

The Horticulturist's Rule-Book.

A Compendium of Useful Information for Fruit-growers, Truck-gardeners, Florists and others. By L. H. BAILEY, Professor of Horticulture in the Cornell University. Third Edition, thoroughly Revised and Recast, with many Additions. 12mo, limp cloth, 75 cents.

Hydrodynamics.

By H. LAMB, M. A., F. R. S., Professor of Mathematics in Owens College, Manchester. Demy 8vo, cloth, \$6.25 net.

A Monograph on the Order of Oligochæta.

By FRANK EVERS BEDDARD, M. A. (Oxon.), F. R. S., Prosector to the Zoological Society of London, and Lecturer at Guy's Hospital. 4to, stiff boards, linen back, \$12.50, net.

Crystallography.

A Treatise on the Morphology of Crystals. By N. STORY-MASKELYNE, M. A., F. R. S., Professor of Mineralogy, Oxford, Honorary Fellow of Wadham College.

MACMILLAN & CO., 66 Fifth Avenue, New York.

SCIENCE

EDITORIAL COMMITTEE: S. NEWCOMB, Mathematics; R. S. WOODWARD, Mechanics; E. C. PICKERING, Astronomy; T. C. MENDENHALL, Physics; R. H. THURSTON, Engineering; IRA REMSEN, Chemistry; J. LE CONTE, Geology; W. M. DAVIS, Physiography; O. C. MARSH, Paleontology; W. K. BROOKS, Invertebrate Zoology; C. HART MERRIAM, Vertebrate Zoology; S. H. SCUDDER, Entomology; N. L. BRITTON, Botany; HENRY F. OSBORN, General Biology; H. P. BOWDITCH, Physiology; J. S. BILLINGS, Hygiene; J. MCKEEN CATTELL, Psychology; DANIEL G. BRINTON, J. W. POWELL, Anthropology.

FRIDAY, JULY 12, 1895.

CONTENTS:

| | |
|--|----|
| <i>The Sun</i> : DAVID P. TODD..... | 29 |
| <i>Current Notes on Physiography (XII.)</i> :..... | 39 |
| <i>Recent Geographical School Books; Teay Valley, West Virginia</i> : W. M. DAVIS..... | |
| <i>Zoological Notes</i> :..... | 41 |
| <i>Monograph of the Crinoids; Fishes of the Colorado Basin. Skeletons of Zeuglodon</i> : F. A. L..... | |
| <i>Scientific Notes and News</i> :..... | 43 |
| <i>Botanical Survey of Nebraska; M. Andrée's Polar Expedition; The Upper Regions of the Atmosphere; Lightning in the United States; General.</i> | |
| <i>Educational and University News</i> | 47 |
| <i>Correspondence</i> :..... | 48 |
| <i>A Bibliography of Scientific Literature</i> : A. RAMSAY. <i>Hack Tuke Memorial</i> : G. F. BLANDFORD..... | |
| <i>Scientific Literature</i> :..... | 51 |
| <i>L'Année psychologique</i> : E. B. DELABARRE. <i>Iowa Geological Survey</i> : J. F. KEMP. <i>Hygiene.</i> | |
| <i>Scientific Journals</i> :..... | 55 |
| <i>The American Geologist; The Monist.</i> | |
| <i>New Books</i> | 56 |

MSS. intended for publication and books, etc., intended for review should be sent to the responsible editor, Prof. J. McKeen Cattell, Garrison on Hudson, N. Y. Subscriptions and advertisements should be sent to SCIENCE, 41 N. Queen St., Lancaster, Pa., or 41 East 49th St., New York.

THE SUN.

"It is because the secrets of the Sun," says Mr. Lockyer, "include the cipher in which the light messages from external Nature in all its vastness are written, that those interested in the 'new learning,' as the chemistry of space may certainly be considered, are anxious to get at and possess them." But even more significant to dwellers on the Earth are the heat radiations of the Sun, because they are determi-

nant in all animal and vegetable life, and are the original source of nearly every form of terrestrial energy recognized by mankind. Through the action of the solar heat-rays the forests of palæozoic ages were enabled to wrest carbon from the atmosphere and store it in forms afterward converted by Nature's chemistry into peat and coal; through processes incompletely understood, the varying forms of vegetable life are empowered to conserve, from air and soil, nitrogen and other substances suitable for and essential to the life maintenance of animal creatures. Breezes operant in the production of rain and in keeping the air from hurtful contamination; the energy of water, in stream and dam and fall; trade winds facilitating commerce between the continents; oceanic currents modifying coast climates (and no less the tornado, the waterspout, the typhoon, and other manifestations of natural forces, excepting earthquakes, frequently destructive to the works of man), all are traceable primarily to the heating power of the Sun's rays acting upon those readily movable substances of which the Earth's exterior is in part composed.

The Sun, cosmically speaking, is simply a star, but the nearest fixed star is 275,006 times more remote; so that the Sun's vastly greater brightness is, for the most part, due to mere proximity. Still, the distance of the Sun is by no means easy to conceive or

illustrate. Recalling that the distance round the Earth's equator is about 24,000 miles, ten times this gives the distance of the Moon, which is practically inconceivable; but the Sun is 390 times more remote. As the two bodies are about the same in apparent size, it follows that the Sun's actual diameter is about 390 (accurately 400) times greater than the Moon's.

The available methods of ascertaining the Sun's distance, more than a dozen in number, may be divided into three classes: (1) by geometry or trigonometry; (2) by gravitational effects of Sun, Moon and planets; (3) by the velocity of transmission of light. The first includes transits of Venus, and near approaches of the Earth to Mars, or to small planets exterior thereto, at which times the distances of these bodies from the Earth are not difficult to measure. Adopting, with Professor Young, the number 100 as indicating a method which would insure absolute accuracy, this class of determinations will range all the way from 20 to 90. The second class of methods, too mathematical for explanation here, depends on the Earth's mass, and their present value may be expressed as 40 to 70; but the peculiar nature of one of them (utilizing the disturbances which the Earth produces in the motion of Venus and Mars) offers an accuracy continually increasing, so that 200 years hence it alone will have settled the Sun's distance with a precision entitled to the number 95. But the best methods now available are embraced in the third class, which employ the velocity of light (determined by actual physical experiment), and their present worth is about 80 or 90. The problem of the Sun's distance is one of the noblest ever grappled by the mind of man; and no one of the numerous elements with which it is complexly interwoven can yet be said to have been determined with the highest attainable precision.

An admirable summary of investigation

of the Sun's distance is given by Dr. Gill as an introduction to Mrs. Gill's *Six Months in Ascension* (London, 1880), an account of an expedition to that island three years previously. The value of the Sun's parallax, $8''.848 \pm 0''.013$, determined by Professor Newcomb (*Washington Observations*, 1865), and now become classic, is adopted in all the national astronomical ephemerides except the French, which adheres to a larger value of Le Verrier. Independent determinations of this constant below given show the measure of modern precision in this important field of research; and the relations of the values to each other will be apparent on recalling that the addition of $0''.01$ to the Sun's parallax is equivalent to diminishing his distance about 105,000 miles:

| | | | |
|---------------------|--|---------------|-------------------|
| (1880) TODD | Velocity of Light | " " | 8.808 \pm 0.006 |
| (1881) PUISEUX | Contact and Micrometer Observations, Transit of Venus, 1874 | | 8.8 |
| (1881) TODD | American Photographs, Transit of Venus, 1874 | | 8.883 \pm 0.034 |
| (1885) NEWCOMB | Velocity of Light | | 8.794 |
| (1885) OBRECHT | French Photographs, Transit of Venus, 1874 | | 8.81 \pm 0.06 |
| (1887) CRULS | Brazilian Observations, Transit of Venus, 1882 | | 8.808 |
| (1887) E. J. STONE | British Contact-Observations, Transit of Venus, 1882 | | 8.832 \pm 0.024 |
| (1888) HARKNESS | American Photographs, Transit of Venus, 1882 | | 8.842 \pm 0.012 |
| (1889) HARKNESS | Planetary Masses | | 8.795 \pm 0.016 |
| (1890) BATTERMANN | Lunar Occultations | | 8.794 \pm 0.016 |
| (1890) NEWCOMB | Re-discussion Transits of Venus, 1761 and 1769 | | 8.79 \pm 0.034 |
| (1892) AUWERS | German Heliometer Observations, Transits of Venus, 1874 and 1882 | | 8.880 \pm 0.022 |
| (1892) GILL | } Opposition of Small Planets { | (12) Victoria | 8.809 |
| (1893) GILL | | (80) Sappho | 8.811 |
| (1894) GILL & ELKIN | | (7) Iris | 8.825 \pm 0.008 |

Also several other values of this important constant have been derived, and there is an increasing tendency to cluster round the figure $8''.81$.

Professor Harkness published in 1891 a laborious paper entitled *The Solar Parallax and its Related Constants* (Washington Observations, 1885), in which this quantity is treated, not as an independent constant, but as "entangled with the lunar parallax, the

constants of precession and nutation, the parallactic inequality of the Moon, the lunar inequality of the Earth, the masses of the Earth and Moon, the ratio of the solar and lunar tides, the constant of aberration, the velocity of light and the light-equation." Collating the great mass of astronomical, geodetic, gravitational and tidal results which have been accumulating for the past two centuries and applying the mathematical process known as a 'least square adjustment,' he derives the value $8''.809 \pm 0''.006$, giving for the mean distance between the centres of Sun and Earth, 92,797,000 miles. A valuable bibliography of the entire subject concludes Professor Harkness's paper.

Professor Newcomb, in his *Elements of the Four Inner Planets and the Fundamental Constants of Astronomy* (Washington, 1895), on which his new tables of the principal planets of the solar system are founded, derives from his discussion of all existing data a definitive value for the Sun's parallax equal to $8''.790$. This important paper is a supplement to the *American Ephemeris* for 1897.

Possible changes of the Sun's diameter from time to time have been critically investigated by Dr. Auwers, of Berlin, and Professor Newcomb, with negative results; nor are the observations yet made sufficient to disclose any difference between equatorial and polar diameters. The heliometer affords the best means of measuring the Sun's apparent diameter or the angle subtended by its disk. The orbit of the Earth being elliptical, this diameter changes in the inverse proportion of the Earth's varying distance from the Sun; at the beginning of the year it is $32' 32''$ and $31' 28''$ early in July, the mean value being $32' 0''$. Supposing the form of the Earth's orbit unknown, daily measures of the Sun's varying diameter would alone, in the course of a year, enable the precise determination of the figure of the orbit, so accurately can these measures now be made. When at its mean

distance from the Earth, the linear equivalent of one second of arc at the Sun is 450 miles. The present uncertainty in the solar diameter does not much exceed $2''$; that is to say about 900 miles, or quite approximately $\frac{1}{1000}$ of the entire diameter. Dr. Auwers's recent value of the semi-diameter is $15' 59''.63$; and if we take the mean distance of the Sun at 93,000,000 miles, this numerical relation gives the Sun's diameter 865,350 miles.

A simple relation between the Sun's mass and its dimensions relatively to the Earth enables us to determine that the force of gravity at the Sun's surface is $27\frac{3}{8}$ times greater than it is here; so that while a body on the Earth falls only 16.1 feet in the first second of time, at the Sun its fall in a corresponding interval would be no less than 444 feet. If a ball clock were transported to the Sun, its leisurely pendulum would vibrate more than five times as rapidly. So great is the Sun's mass that a body falling freely toward it from a distance indefinitely great would, on reaching the Sun, have acquired a velocity of 383 miles per second. The great Krupp gun exhibited at the World's Fair in 1893, if fired from Chamounix in the direction of Mont Blanc, at an elevation of 44° , would propel its projectile of 475 pounds in a curve meeting the earth at Pre-Saint-Didier, $12\frac{1}{2}$ miles from Chamounix, and whose highest point would be more than a mile above the summit of Mont Blanc. If we could suppose the same gun to be fired similarly on the Sun, so great is the force of gravity there that the projectile would be brought down to rest about half a mile from the muzzle.

From groups of the faculæ, Dr. Wilsing has found that the Sun's equator revolves in $25^d.23$; but these observations are exceedingly difficult, and a repetition of the work is desirable. Professor Young and Dr. Crew have determined the period of rotation of the Sun's equator by means of the

spectroscope, utilizing that technicality called Doppler's principle. This means that the spectra from opposite sides of the Sun (the east side coming toward the Earth, and the west receding from us) are optically brought alongside each other; then careful measurement of the amount of divergence of a given line in the two spectra forms the basis for calculating the rapidity of rotation. M. Duner, of Lund, Sweden, carrying this research still farther, into high solar latitudes, finds for the equatorial regions a period of sidereal rotation equal to $25^d.46$, in close correspondence with the determinations of Carrington and Spoerer from the spots alone; while the slowing down as the poles are approached is remarkably verified; for his results give, for the rotation period at latitude 75° , no less than $38^d.54$. M. Duner's observations were made near the time of minimum spots, and it would be interesting to repeat the determination near the epoch of maximum spottedness.

The Sun's axis is inclined 83° to the plane of the Earth's orbit; and if prolonged northward to the celestial sphere, the axis would intersect it near the third magnitude star δ Draconis, so that in March the Sun's north pole is turned farthest from the Earth, in September it is inclined 7° toward us. Spectroscopic study of the sun-spots shows that their inferior brilliance is due in part to a greater selective absorption than obtains in the photosphere generally. Continuous and systematic records of the solar spots are now kept at Greenwich (in connection with Dehra Dun, India), at Potsdam near Berlin, at Chicago, and elsewhere. Exceedingly fine photographs of sun-spots and the solar surface have been obtained at Potsdam (*Himmel und Erde*, ii., 1890, 24).

Also at Meudon, Paris, M. Janssen has had extraordinary success in photographing the Sun's surface in detail, and the granula-

tion is very sharply defined in his originals. In viewing the Sun with a telescope this granulation can be satisfactorily seen with a magnifying power of about 400 or 500, under good atmospheric conditions.

While the 42 years' faithful work of Schwabe, as revised by Wolf and collated with other and scattering results, gives an average sun-spot period of $11\frac{1}{2}$ years, there are great irregularities. During the latter half of the 17th century, the ordinary progress of the spot cycle appears to have intermitted; the intervals between maxima have varied from 8 to $15\frac{1}{2}$ years, and between minima from 9 to 14 years. True interpretation of this indicates with an approach to certainty that the cause of the periodicity does not lie in planetary or any exterior agency, but that it is seated in the Sun itself.

The solar prominences, or hydrogen flames, are drawn in full sun-light, by means of a spectroscope adjusted delicately on the edge of the Sun, this instrument reducing the sky-glare, without dispersing very much the light of the prominence itself. This method has now been in common use more than a quarter century. But by means of the spectro-heliograph devised by Professor Hale, of the University of Chicago, the hindering effects of our atmosphere are in greater part evaded; and he is enabled to secure on a single plate (with single exposure) not only the photosphere and sun-spots, but the chromosphere and protuberances. Also the same instrument (which utilizes monochromatic light, or light of a single color only) has demonstrated that the faculæ, which to the eye are ordinarily seen only near the Sun's limb, actually extend all the way across the disk of the Sun, in approximately the regions of greatest spot-frequency. Professor Hale's progressive methods of solar research will soon give us large accumulations of facular observations, from which the

laws of their appearance may be finally determined, and their connection with the formation of spots and prominences satisfactorily made out. Similar results from the work of M. Deslandres, of the Paris Observatory, are given in Mr. Maunder's paper in *Knowledge*, for January, 1895.

Both spots and prominences have a well recognized variation in heliographic or solar latitude; the former has been investigated by Dr. Spoerer of Potsdam, and the latter by M. Riccò of Palermo. Just before the epoch of a minimum (1888, for example) the spots are seen nearest the Sun's equator; coincidentally with the minimum these circum-equatorial spots cease, and a series breaks out afresh in high solar latitudes. Thenceforward to the time of the next minimum the mean latitude of the spots tends to decline continuously. This fluctuation is called 'the law of zones.' Dr. Spoerer's investigations further show an occasional predominance of spots in the Sun's southern hemisphere not counterbalanced by a corresponding appearance in the northern. Also, during the last half of the seventeenth century and the early years of the eighteenth, there seems to have been a remarkable interruption of the ordinary course of the spot cycle, and the law of zones, too, was apparently in abeyance. The latitude variations of the prominences follow quite closely the fluctuations of the spots, although exhibiting a greater divergence between the Sun's two hemispheres than the spots do.

Independently of his light and heat, the Sun's supreme right to rule his family of planets is at once apparent from his superior size, and from his vastly greater mass. Relative weights of common things readily give a notion sufficiently precise: let the ordinary bronze cent represent the weight of the Earth; Mercury and Mars, then, the smallest planets, would, if merged in one, equal an old-fashioned silver three-cent

piece; Venus, a silver dime; Uranus, a gold double-eagle and a silver half-dollar (or, what is about the same thing in weight, a silver dollar, half dollar, and a quarter dollar taken together); Neptune, two silver dollars; Saturn, eleven silver dollars; Jupiter, rather more than two pounds avoirdupois (37 silver dollars); while the sun, outweighing 750 times all the planets taken together, would somewhat exceed the weight of the long ton.

As the Sun shines with inconceivably greater power than any terrestrial source, an idea of its total light is difficult to convey intelligibly in terms of the ordinary standards adopted by physicists. Its intrinsic brightness, or amount of light per square unit of luminous surface, exceeds the glowing carbon of the electric arc light about $3\frac{1}{2}$ times, or the glowing lime of the calcium light about 150 times. "Even the darkest part of a sun-spot outshines the lime light" (Young). Some rude notion of the total quantity of light received from the Sun is perhaps obtainable on comparison with the average full moon, whose radiance the Sun exceeds 600,000 times. In consequence of absorption of the Sun's light by its own atmosphere, the Earth receives very much less than it otherwise would; while if the absorbing property of the atmosphere were entirely removed, the Sun would (according to Professor Langley) shine two or three times brighter, with a color decidedly blue, resembling the electric arc. As a further effect of this absorption, the intrinsic brightness at the edge is $\frac{2}{3}$ that of the centre of the disk (according to Professor Pickering); and Dr. Vogel makes the actinic or photographic intensity only $\frac{1}{4}$ for the same region. While this shading off towards the edge is at once apparent to the eye, when the entire Sun is projected on a screen, the rapid actinic gradation is more marked in photographs of the Sun, which strongly show the effect of under-exposure near the

limb, if the central regions of the disk have been rightly timed.

Kirchhoff in 1858 formulated the following principles of spectrum analysis: (1) Solid and liquid bodies (also gases under high pressure) give, when incandescent, a continuous spectrum; (2) gases under low pressure give a discontinuous but characteristic bright-line spectrum; (3) when white light passes through a gas, this medium absorbs rays of identical wave-length with those composing its own bright-line spectrum. These principles fully account for the discontinuous spectrum of the Sun, crossed, as it is, by the multitude of Fraunhofer lines. But it must be observed that the relative position of these lines will vary with the nature of the spectroscope used; with a prism spectroscope the relative dispersion in different parts of the spectrum varies with the material of the prism; with a grating spectroscope (in which the dispersion is produced by reflection from a gitter or grating, ruled upon polished speculum metal with many thousand lines to the inch), the dispersion is wholly independent of the material of the gitters, and it is called, therefore, the normal solar spectrum. Compared with this a prismatic spectrum has the red end unduly compressed, and the violet end as unduly expanded.

Rutherford, assisted by Chapman, ruled excellent gratings mechanically; but the last degree of success has been attained by Professor Rowland, of Baltimore, whose ruling engine covers specular surfaces, either plane or concave, six inches in diameter with accurate lines, up to 20,000 to the inch. The concavity of the gratings vastly simplifies the accessories of the spectroscope for researches in which they are applicable. So great is the dispersion obtainable that the solar spectrum, as photographed by Rowland with one of these gratings and enlarged three-fold, is about forty feet in length. The superiority of his

ruling engine consists primarily in the accurate construction and perfect mounting of the screw, which has 20 threads to the inch, and is a solid cylinder of steel, about 15 inches long and $1\frac{1}{8}$ inches in diameter. (Article 'Screw,' *Encyclopædia Britannica*, 9th edition.) The perfect gratings ruled with this engine are now supplied to physicists all over the world.

By means of a spectroscope properly arranged with suitable accessories, the Sun's spectrum has been both delineated and photographed alongside of the spectra of numerous terrestrial substances. Foremost among recent investigators in this field, and in mapping the solar spectrum, are Thollon in France, Lockyer and Higgs in England, Thalén in Sweden, Smyth in Scotland, and in America Rowland, Young, Trowbridge and Hutchins. Their research, together with that of previous investigators, principally Kirchhoff and Angström, Vogel and Fievez, has led to the certain detection of at least 35 elemental substances in the Sun, among which are:

| | |
|-----------------|-----------------|
| (Al) Aluminium. | (Ag) Silver. |
| (Ba) Barium. | (C) Carbon. |
| (Cd) Cadmium. | (Ca) Calcium. |
| (Co) Cobalt. | (Cu) Copper. |
| (Cr) Chromium. | (Fe) Iron. |
| (H) Hydrogen. | (Mg) Magnesium. |
| (Mn) Manganese. | (Ni) Nickel. |
| (Na) Sodium. | (Si) Silicon. |
| (Sc) Scandium. | (Ti) Titanium. |
| (V) Vanadium. | (Zn) Zinc. |

Hydrogen, iron, nickel, titanium, calcium and manganese are the most strongly marked. All the oxygen lines of the solar spectrum are due to the oxygen of our atmosphere. Chlorine and nitrogen, so abundant on the Earth, and gold, mercury, phosphorus and sulphur, are as yet undiscovered. Also the solar spectrum appears to indicate the existence of many metals in the Sun not now recognized upon the Earth; but it must be remembered that our globe is known only

superficially, and there is every reason for believing that the Earth, if heated to incandescence, would afford a spectrum very like that of the Sun itself.

The chemical spectra of many metallic elements freed from impurities are not yet fully known, but these are in the process of thorough investigation by Rowland, and Kayser and Runge of Hanover. Their researches will make possible a more searching comparison with the solar spectrum, hundreds of the dark lines in which are due to absorption by the Earth's atmosphere, and are consequently called telluric lines. Especial studies of these have been made by MM. Janssen, Thollon and Cornu, Becker and McClean. Whether the solar spectrum is constant in character is not known; with a view to the determination of this question in the future, Professor Piazzzi Smyth conducted a series of observations for fixing the absolute spectrum in the year 1884. Mr. Higgs, of Liverpool, studying those strikingly marked bands in the solar spectrum due to the absorption by oxygen in our atmosphere, and known as 'great B' and 'great A,' finds that the double lines are in rhythmic groups, in harmonious sequence, capable of representation by a simple geometric construction.

Regarding the solar spectrum (prismatic) as a band of color merely, the maximum intensity of heat rays falls just below the red (at some distance inferior to the dark Fraunhofer line A); and that of light falls in the yellow (between *D* and *E*); and that of chemical or photographic activity, in the violet (between *G* and *H*); but in the normal spectrum these three maxima are brought more closely together, approaching the middle of the spectrum, which nearly coincides with the yellow *D* lines of sodium.

Beyond the red in the solar spectrum is a vast region wholly invisible to the human eye; but modern physicists have devised

methods for mapping it with certainty. Sir John Herschel, J. W. Draper and Becquerel were the pioneers in this research, the last utilizing various phosphorescent substances upon which an intense spectrum had been projected for a long time. Direct photographic maps of the infra-red regions are very difficult, because the actinic intensity is exceeding feeble; and Abney, by means of collodion plates specially prepared with bromide of silver, has made an extended catalogue of the invisible dark bands. But Professor Langley has pushed the mapping of the infra-red spectrum to an unexpected limit by means of the bolometer, a marvellously sensitive energy-measurer of his own invention. In order to understand in outline the operation of the bolometer, or spectro-bolometer, it is necessary to recall that, as the temperature of a metal rises, it becomes a poorer conductor of electricity; as it falls its conductivity increases, iron at 300° below centigrade zero being, as Professor Dewar has shown, nearly as perfect an electrical conductor as copper. The characteristic feature of the bolometer is a minute strip of platinum leaf, looking much like an exceedingly fine hair or coarse spider web. It is about $\frac{1}{4}$ inch long, $\frac{1}{100}$ inch broad, and so thin that a pile of 25,000 strips would be only an inch high. This bolometer film, then, having been connected into a galvanometer circuit, is placed in the solar spectrum formed either by a grating or through the agency of rock salt prisms; and as it is carried along the region of the infra-red, parallel to the Fraunhofer lines, the fluctuations of the needle may be accurately recorded.

In this manner he first represented the Sun's invisible heat spectrum in an energy-curve; but his recent application of an ingenious automatic method, accessory to the bolometer, has enabled him to photograph its indications in a form precisely compar-

able with the normal spectrum. Bolography is the name given by Professor Langley to these processes which, by the joint use of the bolometer and photography, have automatically produced a complete chart of the invisible heat spectrum equal in length to ten times the entire luminous spectrum of the Sun, though indications of heat extend still farther. A fuller account of Professor Langley's significant work will be found in *Nature*, Vol. 51, (1894), p. 12, and in the new *Astrophysical Journal* for February, 1895, published at the University of Chicago. The bolometer was built by Grunow of New York, and forms part of the equipment of the astrophysical observatory of the Smithsonian Institution at Washington. So sensitive is this delicate instrument that it is competent to detect a temperature fluctuation as minute as the millionth part of a degree centigrade. It is proper to add that the researches conducted with such an instrument, often appearing remote and meaningless to a layman, are eminently practical in their bearing, as they pertain directly to the way in which the Sun affects the Earth, and man in his relations to it; and to the method of distribution of solar heat, forming thus, among other things, a scientific basis for meteorology.

At the end of the solar spectrum remote from the red is the ultra-violet region, ordinarily invisible; a portion of which may, however, be seen by receiving it upon uranium glass or other fluorescent substances. Glass being nearly opaque to the short wave-lengths of violet and ultra-violet, the optical parts of instruments for this research are made of quartz or calc-spar, or the necessary dispersion is obtained by using the diffraction grating. The superior intensity of the chemical or actinic rays in this region renders photography of especial service; and sensitive films stained with various dyes have been effectively employed. The painstaking investigations of

Rutherford, Cornu, H. Draper, Rowland and Vogel have provided splendid maps of the invisible ultra-violet spectrum, exceeding many times the length of the visible spectrum. The farther region of the ultra-violet is pretty abruptly cut off by the absorptive action of our atmosphere.

The constant of solar heat, first investigated by Herschel and Pouillet in 1837-38, was redetermined by Professor Langley in 1881. He adopts *three calories* (small) as the solar constant, which signifies that "at the Earth's mean distance, in the absence of its absorbing atmosphere, the solar rays would raise one gramme of water three degrees centigrade per minute for each normally exposed square centimetre of its surface. * * * Expressed in terms of melting ice, it implies a solar radiation capable of melting an ice-shell 54.45 metres deep annually over the whole surface of the Earth." Professor Langley's *Researches on Solar Heat and its Absorption by the Earth's Atmosphere; A Report of the Mount Whitney Expedition*, were published as No. xv. of the *Professional Papers of the Signal Service* (Washington, 1884).

To express the solar heat in terms of energy: When the Sun is overhead, each square metre of the Earth's surface receives (deducting for atmospheric absorption) an amount of heat equivalent to $1\frac{1}{2}$ horsepower continuously. In solar engines like those of Ericsson and Mouchot about $\frac{2}{3}$ of this is virtually wasted. Of heat radiation emitted from the Sun and passing along its radius, Professor Frost finds that about $\frac{1}{4}$ part is absorbed in the solar atmosphere, which, were it removed, would allow the Earth to receive from the Sun 1.7 times the present amount. Imagine the hemisphere of our globe turned towards the Sun to be covered with horses, arranged as closely together as possible, no horse standing in the shadow of any other; then cover the opposite hemisphere with an equal number of horses: the solar energy intercepted by the

Earth is more than equivalent to the power of all these animals exerting themselves to the utmost and continuously.

It is easy to show that "the amount of heat emitted in a minute by a square metre of the Sun's surface is about 46,000 times as great as that received by a square metre at the Earth, * * * that is, over 100,000 horsepower per square metre acting continuously." * * * (Young.) If the Sun were solid coal this rate of expenditure would imply its entire combustion in about 6,000 years. The effective temperature of the Sun's surface is difficult to determine, and has been variously evaluated, from the enormously high estimates of Secchi, Ericsson and Zöllner, to the more moderate figures of Spoerer and Lane, who deduced temperatures of 80,000° to 50,000° Fahrenheit. According to Rosetti, it is no less than 18,000° Fahrenheit, an estimate probably not far wrong. M. Le Chatelier, however, in 1892, found the temperature a little short of 14,000°, and Wilson and Gray about 12,000°. Dr. Scheiner's recent observations upon the peculiar behavior of two lines in the spectrum of magnesium confirm these lower values in a remarkable way, apparently showing that the Sun's temperature lies between that of the electric arc (about 6,000°) and that of the electric spark (probably as high as 20,000°). A still later value is 40,000° C., derived by Herr Ebert of Kiel in 1895, by a method, however, involving much theoretic uncertainty.

The maintenance of this stupendous outlay of solar energy is explainable on the theory advanced by Von Helmholtz in 1856, who calculated that an annual contraction of 250 feet in the Sun's diameter will account for its entire radiation in a year—a rate of shrinkage so slow that many centuries must elapse before it will become detectable with our best instruments. Accepting this theory, Lord Kelvin estimates that the Earth cannot have been

receiving the Sun's light and heat longer than 20,000,000 years in the past; and Professor Newcomb calculates that in 5,000,000 years the Sun will have contracted to one-half of its present diameter, and it is unlikely that it can continue to radiate sufficient heat to maintain life of types now present on the Earth longer than 10,000,000 years in the future. But it is now known that there are elements neglected in this computation which render a revision necessary and will probably extend this time very greatly. Assuming that solar heat is radiated uniformly in all directions, computation shows that all the known planets receive almost a two-hundred-millionth part of the entire heat given out by the Sun, the Earth's share being about $\frac{1}{10}$ of this. The vast remainder seems to us essentially wasted, and its ultimate destination is unknown.

To epitomize Professor Young's statement of the theory of the Sun's constitution, generally accepted:

(a) The Sun is made up of concentric layers or shells, its main body or nucleus being very probably composed of gases, but under conditions very unlike any laboratory state with which we are acquainted, on account of the intense heat and the extreme compression by the enormous force of solar gravity. These gases would be denser than water, and viscous, in consistency possibly resembling tar or pitch.

(b) Surrounding the main body of the Sun is a shell of incandescent clouds, formed by condensation of the vapors which are exposed to the cold of space, and called the photosphere. Telescopic scrutiny shows that the photosphere is composed of myriad 'granules' about 500 miles in diameter, excessively brilliant, and apparently floating in a darker medium.

(c) The shallow, vapor-laden atmosphere in which the photospheric clouds appear to float is called the 'reversing layer,' because

its selective absorption produces the Fraunhofer lines in the solar spectrum. It probably is somewhat less than 1,000 miles in thickness. The reversing layer contains a considerable quantity of those vapors which have given rise to the brilliant clouds of the photosphere, just as the terrestrial atmosphere adjacent to clouds is itself saturated with the vapor of water.

(d) The chromosphere and prominences are permanent gases, mainly hydrogen and helium, mingled with the vapors of the reversing layer but rising to far greater elevations than the vapors do. Jets of incandescent hydrogen appear to ascend between the photospheric clouds, much like flames playing over a coal fire. Calcium vapor is the most intensely marked of all the metals in the solar spectrum, even more so than of iron, which has over 2,000 line-coincidences, while calcium has only about 80.

(e) Still above photosphere and prominences is the corona, hitherto observable only during total eclipses, and extending to elevations far greater than any truly solar atmosphere possibly could. The characteristic green line of its spectrum, due to a substance not yet discovered on the Earth, and hence called 'coronium,' is brightest close to the Sun's limb, and during the eclipse of 1st January, 1889, it was traced outward by Professor Keeler to a distance of 325,000 miles. But much of the coronal light is known to originate in something other than the gaseous incandescence of hydrogen and coronium, because of the dark lines seen to cross its spectrum. These indicate solar light, reflected probably from small meteoric particles, possibly the debris of comets, circulating about the Sun in orbits of their own.

Dr. Huggins and Dr. Schuster maintain the view that the coronal streamers are in part due to electric discharges. The corona appears to be a very complex phenomenon, and as yet it is only in part under-

stood. Two rival theories are now prominent; Mr. Schaeberle's mechanical theory (*Lick Observatory Reports on the Total Eclipse, 22d December, 1889*), and Professor Bessel's theory (*The Solar Corona discussed by Spherical Harmonics*, Washington, 1889), that the coronal light is merely a phenomenon of the Sun's magnetism. But neither of these theories has yet been shown competent to undergo the ultimate test—that of predicting the general configuration of the coronal streamers at future eclipses.

Among modern solar theories may be mentioned that of Schmidt (1891), an optical theory of the solar disk, making the Sun wholly gaseous, in fact, a planetary nebula, existing in space without a definite outline anywhere, as we see it; so that the photosphere would be an apparent or optical surface merely, and not a real or natural one, such as the Sun's disk and limb seem actually to be in the telescope. The best English exposition of Schmidt's theory is that of Herr Wilczynski of Berlin, in the February (1895) number of the *Astrophysical Journal*; followed in the same issue by Professor Keeler's clear statement of certain practical objections to this theory. If Schmidt's theory were true, it is exceedingly improbable that the Sun's apparent or angular diameter would remain practically a constant quantity, as we know it does. Also may be mentioned the theory of the Sun by Dr. Brester of Delft, published in 1892, and characterized by much novelty. Rejecting the hypothesis of eruptive translation of solar matter, he conceives the Sun to be a relatively tranquil gaseous body, of essentially the same elementary composition as our Earth; and he attempts to show, in accordance with well known properties of matter, that the same cause which would keep the mass in repose must produce also 'chemical luminescence,' as he terms it. Great material eruptions, then, are merely deceptive appearances, be-

ing simply moving flashes in tranquil incandescent gases. Neither of these theories, however, is accepted to any great extent by practical students of the Sun and observers of solar phenomena.

The surface of the Sun (photosphere, spots, faculae and prominences) is now a subject of daily study at many observatories, particularly at Potsdam, Meudon, Rome, and the Kenwood Observatory of the University of Chicago, where Professor Hale has instituted many significant innovations, in which he has been closely followed by M. Deslandres, of Paris; and observations are rapidly accumulating, the complete discussion of which ought soon to settle many points in the solar theory now disputed. But as the Sun's corona is visible only a few hours in a century, our knowledge of that object makes haste very slowly, and must continue to do so, unless the photographic method of Dr. Huggins (apparently successful in 1883, though later not), or of other investigators, shall make it possible to study the brighter streamers of the corona without an eclipse. Results of a patient series of recent attempts, however, are not encouraging. But it is well worth noting that an application of Professor Langley's bolometer, lately proposed by Professor Hale, though not yet put into execution, may still enable us to map the corona at any time by means of the minute variations in its heat from part to part. And many astronomers are hopeful that this ingenious suggestion may yet give a trustworthy outline picture of the corona in full sunlight, although the ability to picture it directly may forever be denied.

AMHERST COLLEGE.

DAVID P. TODD.

CURRENT NOTES ON PHYSIOGRAPHY (XII).

RECENT GEOGRAPHICAL SCHOOL BOOKS.

PROFESSOR SPENCER TROTTER'S 'Lessons in the New Geography' (Heath & Co., Boston, 1895) was referred to with approval

in the Current Notes on Anthropology in SCIENCE for March 8th; but its geographical features are not altogether satisfactory. The spirit of the book is excellent. It does a good work in emphasizing the control that geographical conditions exercise over the distribution of plants, animals and man; but its physiographic foundation is not secure; the two brief chapters on the general forms of land and water and on climate and meteorology do not present the better modern views on these subjects; and the chapters on the geographical distribution of life, to which special attention is paid, do not satisfy the expectations of the biologist, as far as I have made inquiry. The faunal divisions recognized for America belong to the past; while the latest results, based on positive knowledge of the facts of distribution and of the facts of temperature control, are not mentioned. It is to be hoped that these deficiencies will be corrected in a later edition.

'Short Studies in Nature Knowledge,' an introduction to the science of physiography by William Gee, certified teacher of the education department (London, Macmillan, 1895), is one of a class of attractive books, whose object is to make geography better worth studying. Its entertaining chapters are well illustrated, if exception is made of certain exaggerated pictures, such as that of the Susquehanna, p. 121; but the book lacks a strong and scientific basis. The reader will probably be interested and attracted to further study; but he will not be impressed with the system and order of Nature's processes. As is so often the case, the impossible is attempted in giving an elementary explanation of the general circulation of the winds.

'A Brief Descriptive Geography of the Empire State,' by C. W. Bardeen (Bardeen, Syracuse, N. Y., 1895, 75 cents), is intended for local use, giving an account of the general topography, surface (mountains,

rivers, lakes, waterfalls, etc.), geology, climate and productions, political divisions, education, and railway journeys; the latter heading occupying a third of the book. There are numerous illustrations, many of which are well chosen and well produced. Twenty-five small outline maps are used to exhibit the distribution of various features. Yet, on the whole, the book is an empirical treatment of a rational subject. Not nearly enough is made of the physical features of the State, as to their origin on the one hand, and as to their control over conditions of life on the other hand. The attitude of the author regarding physiographic processes may be judged from an extract: "The valleys [of the Finger Lakes] seem like immense ravines, formed by some tremendous force, which has torn the solid rocks from their original beds;" a foot note adding—"The force that effected these immense changes was probably great currents of water from the N." The disregard of geological structure as a basis of geographical subdivision is indicated by the following: "Three distinct mountain masses or ranges enter the State from the S. and extend across it in a general NE. direction." Then after accounts of the Highlands and the Catskills we read: "*The Adirondacks*.—The third series of mountains enters the State from Pennsylvania and extends NE. through Broome * * * * and Herkimer counties to the Mohawk, appears upon the N. side of that river, and extends NE., forming the whole series of highlands that occupy the NE. part of the State, generally known as the Adirondack Mountain region" (p. 19). This association of a part of the sedimentary Allegheny plateau with the crystalline Adirondacks is altogether unwarrantable, especially as the two are separated by a well defined subsequent lowland.

A common difficulty pervades these three books; they are not based on a serious, thorough, scientific study of geography.

TEAY VALLEY, WEST VIRGINIA.

THE topographical sheets of the U. S. Geological Survey for West Virginia include the path of Teay Valley, a wide-open, clay-floored trench running east and west through the hilly plateau, from the Kanawha Valley a little below Big Coal River, to the Ohio Valley a little above Huntington, but not followed by any proportionate stream. It has been stated that 'the valley is clearly enough a remnant of early erosion, when the water of the Upper Kanawha took that course to join the Ohio' (Wright, Bull. 58, U. S. G. S., 87); but this is not satisfactory, for if the master stream of the region ever followed this course, how was it ever diverted to any other course? The following alternative explanation is offered, in the hope that it may be criticized by special observation on the ground.

The diversion of one stream by another flowing in the same general direction in a region of horizontal strata is comparatively rare; if it happens, it is usually the result of the lateral swinging of a larger toward a smaller one. At the moment of contact, the larger one, which has the lower grade, laterally abstracts the smaller one, which has the higher grade. The Cumberland in western Kentucky is in some danger of this sort of abstraction by the Tennessee, and if that region were now uplifted, the abstraction might easily result from the increased lateral meandering that would be there introduced. Lateral abstraction seems to have been actually practised on the Big Coal River by the Kanawha; Teay Valley being the lower abandoned course formerly followed by the Big Coal. In France, crystalline pebbles carried by the Moselle from the Vosges mountains into the valley of the Meuse show plainly enough a former arrangement of drainage unlike the present; but the monotonous sandstones of the Allegheny plateau in the Kanawha and Big Coal River basins pro-

bably forbid the application of this test to the case of the Teay Valley. Can any other test be suggested?

W. M. DAVIS.

HARVARD UNIVERSITY.

ZOÖLOGICAL NOTES.

A MONOGRAPH OF CRINOIDS.*

THE crinoids of the Paleozoic rocks of North America are so rich and varied in form, so numerous in individuals, that they have long been the delight and the despair of naturalists. Especially is this the case with that order of the crinoids to which the name *Camerata* is now generally applied, the order that includes such well-known forms as the Nava Encrinite, *Actinoecrinus*, and the Rose Encrinite, *Rhodocrinus*, which are common enough in our own Mountain Limestone, together with the flatter and simpler form, *Platycrinus*. For, in America, there are added to these ordinary genera such remarkable creatures as the huge *Megistocrinus*: the speared and spined *Dorycrinus*; the peculiar mushroom-like *Agaricocrinus*; *Strotocrinus*, like a college don in his mortar-board; *Eretmocrinus*, with its broad oar-like arms; *Pterotocrinus*, whose lofty dome is surmounted by wings; *Gilbertocrinus*, with strange drooping appendages of unknown function, and *Batoecrinus*, whose pores at the bases of the arms are equally mysterious. But this list does not include a quarter of the camerate or vaulted genera known from the Carboniferous rocks of America alone; while, if we accept the work of Mr. S. A. Miller and kindred spirits, the long line will stretch out to the crack of doom. Such, indeed, is the variety of form, and such the rashness of interpretation of some of the more enthusiastic collectors and describers, that to us European students the subject has become one of in-

extricable complexity. It is, therefore, with peculiar pleasure that we learn an authoritative monograph of these wonderful and beautiful beings is shortly to be issued.

Since the year 1859, or thereby, Charles Wachsmuth, who lives at Burlington, Iowa, in the very heart of the crinoid country, has devoted his life to the study of these animals. A large collection which he made was bought for the Museum at Cambridge, Mass., by Professor Louis Agassiz, at whose invitation Wachsmuth settled at the University to take charge of the whole collection of crinoids. The first-fruits of his study were published in 1877. After a time Wachsmuth returned to Burlington and began to form a second collection; much of this he was, unfortunately for himself, forced to part with, this time to the enrichment of the British Museum, in whose galleries some of his magnificent specimens are displayed. Association with Frank Springer enabled him to continue his collection and his studies, so that the series of fossil crinoidæ made by the two friends is unrivalled even by the great collections of London, Harvard or Stockholm, and their 'Revision of the Paleozoic Crinoids' has long held the front rank among all works on the subject. In their knowledge of the writings of others, in their accurate discrimination of generic and specific characters, and in their important contributions to the morphology of the crinoids, these gentlemen have shown themselves most fitted to prepare that desired necessity, a monograph of the fossil crinoids of North America. The magnitude of the task, the failing health of the elder worker and the business cares of the younger, have prevented the completion of more than a portion, that, namely, which deals with the Crinoidæ *Camerata*. The text of this portion alone will fill between 600 and 700 quarto pages, while no less than eighty-three plates, of extreme beauty, have been drawn by A. M. Westergren, J.

* Reprinted from proofs for *Natural Science* contributed by the Editor.

Ridgway and C. R. Keyes, under the immediate supervision of the authors. It is fitting that Professor Alexander Agassiz and the Museum of Comparative Zoölogy at Harvard should undertake the publication of this monograph. It will appear as one of the Memoirs of the Museum, so soon as the plates can be photographically reproduced from the original pencil drawings—that is, it is hoped, early in 1896. The price will be thirty dollars. As the edition will be limited, intending subscribers are requested to send their names to Professor Agassiz at the earliest possible date. A work of such usefulness and importance needs no recommendation from us; we can only hope that the enterprise of the publishers and the devotion of the workers may meet with due appreciation from the scientific public, and that Charles Wachsmuth and Frank Springer may be spared many years of health and leisure, to place the crown on this worthy monument of American paleontology.

THE FISHES OF THE COLORADO BASIN.

In a paper on the 'Fishes of the Colorado Basin,' just published by the U. S. Fish Commission, Messrs. Evermann and Rutter have brought together all the published information accessible to them concerning the geographic distribution of the fishes of that river basin. Although the Colorado basin is one of the largest in the United States, the number of square miles drained being not less than 225,000, the number of species of fishes found in it is but 32. This number has been taken at a single haul with a 30-foot seine in Bean Blossom Creek, a little stream near Bloomington, Indiana.

The 32 species of the Colorado basin represent 5 families, as follows:

Catostomidae, or suckers, 8; *Cyprinidae*, or minnows, 19; *Salmonidae*, or trout and whitefish, 2; *Peciliidae*, or top-minnows, 2; and *Cottidae*, or blobs, 1.

The *Cyprinidae*, it will be noticed, constitute considerably more than half the entire fish-fauna.

Of the 18 genera represented, *Gila*, *Tiaroga*, *Meda*, *Plagopterus* and *Xyrauchen* are peculiar to that river basin, and a sixth genus, *Lepidomeda*, is known only from the Colorado and the Great Basin in southwestern Nevada, where it was discovered by the Death Valley expedition.

Of the 32 species all but 7 are thus far known only from this basin.

The extreme paucity of the fish-fauna of the Colorado basin will be apparent when it is recalled that 80 different species are known from the basin of the Rio Grande, 140 from that of the Missouri and 130 from the Wabash basin. Only 2 species (*Rhinichthys cataractæ dulcis* and *Coltus bairdi punctulatus*) are found in both the Colorado and Missouri basins, only 2 species (*Agosia oscula* and *Agosia yarrowi*) are found in both the Colorado and the Rio Grande, while not a single species is common to both the Colorado and the Wabash basins.

The *Centrarchidae*, *Percidae* and *Siluridae* (sunfishes and basses, darters and catfish), which constitute such a large and important part of the fish-fauna east of the Rockies, have no representatives in the Colorado basin.

SKELETONS OF ZEUGLONDON.

LAST November Mr. Charles Schuchert collected for the U. S. National Museum portions of two skeletons of Zeuglodon, and these are being used as the basis of a restoration of the entire skeleton for the Atlanta Exposition. Mr. Schuchert has devoted much time to 'developing' the material which promises to throw some needed light on certain portions of this interesting form. The radius and ulna, for example, are present and are more seal-like than cetacean. The hyoid suggests that of a Manatee, and the cervicals present a good

example of animal mechanics, being interlocked so as to be quite rigid. No traces of hind limbs have as yet come to light, but that section of the skeleton where they might have been was unfortunately defective. The material will be described at length in a Bulletin of the National Museum.

Apropos of Zeuglodon Mr. Schuchert characterizes the statement that their remains are so plentiful as to be used for building stone wall as a myth, but it will doubtless continue to live on in text-books in company with the figure of the pouched rat with everted pouches, which has held its place ever since the first description of the animal and seems likely to last indefinitely.

F. A. L.

SCIENTIFIC NOTES AND NEWS.

THE BOTANICAL SURVEY OF NEBRASKA.

In the *American Naturalist*, for June, Professor Charles E. Bessey gives an account of the 'Progress of the Botanical Survey of Nebraska.' The Survey, though a private enterprise, has received encouragement and support from the State Board of Agriculture, the State Horticultural Society and from the University of Nebraska, the work being in the hands of a 'Botanical Seminar' composed of Graduates of the University. The first important work issued by the Survey was H. J. Webber's 'Catalogue of the Flora of Nebraska,' published in 1890 in the Report of the State Board of Agriculture, and also issued as a separate Monograph. In it 1,890 species were enumerated, almost equally divided between flowering and non-flowering plants, nearly all of which were based on actual specimens in the possession of the author. Since this time the work has been steadily continued and the results have been published at frequent intervals, so that the list of known species now catalogued reaches about 3,050. Additional studies have been made in special directions on the distribution of

species. Of the 64 trees and 77 shrubs known to occur in the State the distribution is already well ascertained. The final Report of the survey is in preparation. It will be entitled the *Flora of Nebraska*, and will be issued in twenty-five parts of about 50 pages each. Part I. and part II. were issued in August, 1894 (reviewed in SCIENCE, Jan. 4, p. 25), and part XXII. *The Calyciflora* is now in press.

M. ANDRÉE'S POLAR EXPEDITION.

A COMMITTEE of the Paris Academy of Sciences, consisting of MM. Faye, Daubrée and Blanchard, have reported on the project of M. Andrée to explore the polar regions by balloon. They state that under the circumstances he is likely to reach the pole and will be able to solve many problems of scientific interest. But they fear that the return to inhabited regions will involve serious difficulties.

In the meanwhile M. Andrée is in Paris superintending the construction of a balloon. The balloon is to be of sufficient size to carry three persons, scientific instruments and provisions for four months and a boat transformable into a sledge, weighing in all about 3,000 kg. Gas under pressure in cylinders will be taken in order to refill the balloon from time to time—sufficient to keep the balloon in the air for thirty days.

M. Andrée expects to start from one of the Norwegian Islands of the Spitzbergen Archipelago situated to the extreme northwest of the mainland. July is fixed as the month of departure. A clear day will be chosen with a south wind. The balloon will travel at a minimum rate of 27 km. an hour, and M. Andrée hopes to reach the pole in a voyage of forty-three hours and to return safely to the inhabited regions of North America or Siberia.

According to an account in the *Revue Scientifique* by M. Ch. Rabot, the meteorologist

logical conditions of Spitzbergen are very favorable for a long aeronautical voyage. The sun in July never sinks below the horizon, and the variations of temperature are consequently very slight. The lowest temperature observed in July, 1883, at Cape Thorsen, was $+0^{\circ}.8$ and the highest, $+11^{\circ}.6$. At Spitzbergen, during the first fortnight in August, 1892, the largest daily variation observed was 3° , and as a rule it was not greater than $1^{\circ}.5$. The movements of the balloon would therefore be very regular. There is no storm to be feared in the polar regions. The rainfall is small, and a fall of snow at this time of the year would be no obstacle to the balloon.

THE UPPER REGION OF THE ATMOSPHERE.

ACCORDING to the *London Times*, at the last meeting of the Royal Institution for the present season Professor Alfred Cornu, F. R. S., of the Paris Academy of Sciences, delivered an address in French on the 'Les Phénomènes Physiques des Hautes Régions de l'Atmosphère.'

M. Cornu began by comparing the atmosphere to an immense thermo-dynamic engine, the sun being the source of heat and the interplanetary space the condenser. The most interesting phenomena took place in the almost inaccessible parts of the atmosphere, and though the difficulties of getting information about those elevated regions were great, yet he hoped to show that the physicist was beginning to know much of the real explanation of natural phenomena and was even able to reproduce them in his laboratory. Among the unexpected static phenomena discovered by ballooning and in mountain observatories M. Cornu instanced three—namely, the facts that many clouds which had generally been regarded as consisting of vapour were composed of minute crystals of ice; that at different heights the direction of the wind was different; and that the temperature

did not get steadily lower as the earth became more distant, but that alternate layers of hot and cold air were encountered. The first and last of these facts might have been ascertained by indirect means from consideration of certain optical phenomena. From the solar halo might be inferred the presence of ice crystals in cirrus cloud; they had the power of refracting light, and refraction of the sun's light by passing through cloud would fully explain the halo. It could be reproduced artificially by passing a beam of light through a strong solution of alum, with a little alcohol added. The alternations of heat and cold in the atmosphere were deducible from the various forms of mirage, which depended on the reflection of light from the surface of the different layers. M. Cornu gave an ingenious reproduction of the 'Alpine glow,' sometimes seen in the Bernese Oberland, for an example. A valley between two peaks would become filled with hot air under the influence of the sun, and the path of the rays of light reflected from the surface of the hot layer would be convex as regarded from the earth. After sunset the hot air would rise and the cool take its place, thus producing a hot layer of air above of a cooler one. The light from the sun would now be reflected into a concave ray, which would bend down and illuminate the mountain, though the sun was in fact below the horizon. M. Cornu then proceeded to speak of the dynamic phenomena of the air. He said that the solar energy was of three kinds—mechanical energy (appearing as winds, cyclones, etc.), calorific energy (shown by the change of the state of matter, as of water into vapour), and electrical. He only proposed to deal with the first of these. The wind was the most simple mechanical manifestation and had its origin in the difference of atmospheric pressure in two distant places. It never blew in the direction of the line join-

ing the points of greatest and least pressure, but always obliquely to the isobarometric lines, and usually with a circular movement round the points of highest and lowest pressure. When from any cause the equilibrium of the atmosphere was broken down, circular movements of enormous force, such as tornadoes and cyclones, were set up. The lecture concluded with the exhibition of an artificial waterspout.

LIGHTNING IN THE UNITED STATES.

THE U. S. Department of Agriculture has issued a bulletin on *Protection from Lightning* by Mr. Alexander McAidie, which gives some interesting statistics concerning the prevalence of injury from lightning in the United States.

In 1891 the Weather Bureau issued to its observers instructions to report at the end of every month the names, with corroborative dates and places, of all persons killed by violent wind storms, tornadoes and lightning, as also damage to property.

There were reported in 1891, 204 persons killed; in 1892, 251; in 1893, 209, and in 1894, 336. In addition to those killed during 1894, 351 persons were severely injured. The injury to property during the year was as follows: 268 barns struck with a damage of \$407,500; 55 churches struck, damage unknown; 261 dwellings and several oil tanks, factories and elevators, the damage amounting to not less than \$351,000.

The report strongly recommends the use of lightning conductors in thinly settled districts, but does not give statistics concerning the relative amount of protection supplied by them.

GENERAL.

DANIEL CADY EATON, professor of botany in Yale University, died on June 29th at the age of sixty years.

THERE will be held at Paris in 1896 an *International Congress of Applied Chemistry*.

The committee of organization met at Paris on June 4th to make preliminary arrangements, and decided on the ten sections in which the Congress should meet.

THE Division of Ornithology and Mammalogy, Department of Agriculture, has in press a Bulletin by Professor Beal on the Food of Woodpeckers, an abstract of which was recently given in SCIENCE. Mr. F. A. Lucas has contributed a short chapter on the tongues of woodpeckers, and the relation between the character of the tongue and the nature of the food. He concludes that modifications of the tongue, at least external modifications, are directly due to peculiarities of food or feeding, and are not of taxonomic value.

THE removal of Professor George Davidson, head of the Coast and Geodetic Survey on the Pacific Coast, is severely criticised. Telegrams have been sent protesting against this action from Senators Perkins, White and Allison, and from many others. The officers of the Lick Observatory sent the following dispatch:

LICK OBSERVATORY, July 2d.

To President of the United States, Washington:

The undersigned, astronomers of the Lick Observatory, respectfully call your attention to an act of great injustice done to one of the most active and efficient of our Government employees, Professor George Davidson, for many years connected with the United States Coast Survey, who has been removed from his position. Recently published scientific records demonstrate that he is still one of the most active workers in the Survey. It would be an act of simple justice to reinstate him. We earnestly request you to cause this to be done.

Respectfully,

E. S. HOLDEN,
J. M. SCHAEERLE,
E. E. BARNARD,
W. W. CAMPBELL.

MR. GEORGE S. DAVIS has decided to discontinue the publication of *The Index Medicus*. In a circular letter to the subscribers he states that since 1885 the loss has been between \$500 and \$1,000 annually, and that it would probably amount to \$2,000 in

1895. The discontinuation of *The Index Medicus* will be a serious loss to medical science throughout the world.

SCIENCE PROGRESS, which since its establishment a year and a half ago, has maintained a high standard as a monthly review of current scientific investigation, will hereafter be published in America by D. C. Heath & Co.

DR. FRIEDRICH TIETJEN, professor of higher mathematics in the University of Berlin and director of the bureau of calculation of the observatory, died at Berlin on June 22d.

DR. P. A. A. S. VERNEUIL, professor of surgery in the Hotel-Dieu and eminent for his contributions to surgery, died near Paris on June 11th at the age of 71 years.

DR. LEONARD STEJNEGER has been sent by the United States Fish Commission, with the permission of the State Department of Russia, on a special mission to the Commander Group of Islands with a view to investigating the fur seals.

MR. WILLIS N. MOORE, now in charge of the forecasting office of the Weather Bureau at Chicago, has succeeded Professor Mark W. Harrington as Chief of the Weather Bureau.

DR. HANS WILHELM MEYER, of Copenhagen, died at Venice on June 3d at 71 years of age. His method of removing so-called allenoid vegetations from the lymphoid tissue in the post-nasal space is regarded as one of the most important advances of modern surgery. These growths are said to occur in more than one per cent. of all school children and to be a foremost cause of deafness and deficient bodily and mental development.

M. DAUBRÉE announced, at the meeting of the Paris Academy of Sciences on June 4th, that Dr. Nordenskjöld, professor of mineralogy, geology and geography in the University of Upsala, Dr. Dusen and Dr.

Ohlin will undertake a scientific expedition to Terra del Fuego, in September next, with the coöperation of the Swedish and Argentine governments.

AN expedition into central Africa will shortly be undertaken under the auspices of the Italian Geographical Society, and under the direction of the explorer Captain Bötogo. The party will include the geologists, Prof. de Stefani, of Florence, and Prof. Bucca, of Catania, and the biologists, Prof. Vinciguerra, of Genoa, and Dr. Sacchi, of Rome.

At the Commencement Exercises at Yale University, Prof. George Fisher introduced a resolution of regret, which was unanimously adopted, on the death of Prof. James Dwight Dana. He announced that if \$4,500 more were raised, a pedestal and bust of the late professor would be erected on the campus.

THE neurologists of the United States have subscribed about \$800 towards the monument to be erected in honor of Charcot. The sum of about \$8,000 has been collected for this purpose.

MR. R. F. STUPART has been appointed director of the meteorological service of Canada.

SIR GEORGE HORNIDGE PORTER, regius professor of surgery in the University of Dublin, died on June 20th, at the age of 73.

DR. JOSEPH S. SHAW, professor of chemistry at Rock Hill College, Ellicott City, Md., died suddenly on June 27th.

A 'CONFERENCE OF EVOLUTIONISTS' was held at Eliot, Me., from July 6th to 13th. Among the speakers expected were Prof. E. D. Cope, Prof. E. S. Morse, Mr. John Fiske and Dr. L. G. Janes.

It is stated in *Nature* that the first number of a bimonthly journal for sanitary engineers will be published at Brussels on August 1, under the title *La Technologie Sanitaire*. It will be under the direction of an edi-

torial committee, the secretary of which is M. Victor J. Van Lint, 115 rue Joseph II., Bruxelles. The journal will deal with all questions relating to public health.

L'Association française pour l'avancement des sciences will hold its twenty-fourth session at Bordeaux, August 4th to 9th.

ACCORDING to the Monthly Bulletin of the Board of Health of the State of New York the average daily mortality for the month of May was 308 as compared with 368 for the preceding four months of the year. The improvement was due to the suspension of the epidemic of grip, which began in January.

ARRANGEMENTS are being made by the Marine Biological Association [England] for a series of dredging and trawling expeditions during July, August and September, to investigate the fauna and flora of the outlying grounds between the Eddystone Rocks and Start Point. In order to make the results as complete as possible, it is extremely desirable that the investigation of each group should be carried out by a competent naturalist. Zoölogists and botanists who are willing to take part in these expeditions, or to assist in working out the material collected, are requested to communicate with the director, the Laboratory, Plymouth.—*Academy*.

EDUCATIONAL AND UNIVERSITY NEWS.

On July 29th Judge Ross, in the United States District Court, San Francisco, made a decision in favor of the Stanford estate against the claim of the Government for \$15,000,000.

DR. CARL BARUS, of the Smithsonian Institution, Washington, has accepted the Hazard professorship of physics in Brown University. It is stated that Brown University has recently spent \$100,000 in the building and equipment of a physical laboratory.

A NEW edition of the quinquennial catalogue of Harvard University has been issued from the University press. It now requires a volume of 515 closely printed octavo pages to include the officers and graduates of the University since 1636.

DR. THEOBALD SMITH, Chief of the Division of Animal Pathology in the Bureau of Animal Industry, Department of Agriculture, has been offered a professorship in Howard University.

GEORGE WILLIAM SMITH, who recently declined the presidency of the University of Kansas, has been elected president of Colgate University. He is now professor of history in Colgate University.

MR. ARTHUR F. NESBIT, of Milton, Pa., graduate of the Massachusetts Institute of Technology, has been appointed instructor of physics and electrical engineering in the New Hampshire College of Agriculture.

THE quarterly statement of President Harper, of the University of Chicago, shows that the teaching staff of the university at present consists of 164 professors and instructors. The total enrollment of students for the year has been 1587, and for the summer quarter between 600 and 700 have already registered. The trustees of the Ogden estate have added \$50,000 to the sum already given to the University.

THE University of Vermont has bought for \$12,000 a house at Burlington which will be used as a dormitory for women students.

It is stated that Dr. Pearsons has offered on certain conditions to give \$50,000 each to Berea College and Whitman College.

THE buildings of the University of Missouri destroyed by fire January 9th, 1892, have now been rebuilt at a cost of \$500,000. Seven new buildings are ready for use, including a chemical building, a biological and geological building and a physical and engineering building.

AN effort is being made to collect \$5,000 to improve the library at Wesleyan University. Mr. J. E. Andrus has pledged \$1,000 on condition the rest be raised.

THE Society of the New York Hospital has sold to Barnard College, for \$160,000, a site on the west side of the Boulevard, between 119th and 120th Streets.

THE *Naturwissenschaftliche Rutschau* states that Professor v. Kries has declined the call to the chair of physiology in the University of Leipzig.

AT Zurich Dr. Hans Schinz has been promoted to a full professorship of botany, and Dr. A. Werner to a full professorship of chemistry.

PROFESSOR TREDELENBURG has been called to take Professor Thiersch's place in Leipzig. Professor Mikulicz takes Professor Trendelenburg's place in Bonn.—*N. Y. Medical Record.*

THE Senate of the University of Cambridge has resolved, by a majority of 18 votes, to make an English essay a part of the 'Little go,' or preliminary examination.

THE statute on research degrees at Oxford, which we have already mentioned as of special interest to Americans proposing to study abroad, has passed its final stage in convocation without opposition.

DR. HENRY CALDERWOOD, professor of moral philosophy in the University of Edinburgh, has requested to be retired from the chair in view of his candidature for Parliament.

AT Oxford, on June 17th, the proposal for establishing a Final Honour Examination in Anthropology in the School of Natural Science was discussed in Convocation, and the statute was rejected by 68 votes to 60. According to *Nature* the rejection was due to 'theological suspicions' and 'those classical teachers that believe that science may safely be ignored in a nineteenth century education.'

THE seventh summer meeting of university extension and other students will be held this year at Oxford, and will be divided into two parts, the first lasting from August 1st to August 12th, and the second from August 12th to August 26th. Included in the varied course there will be lectures on natural science during both parts of the meeting, and classes will be formed for practical work in the different divisions. Among those who have promised to lecture are Professors Green and Odling; Drs. Fison and Wade; Messrs. Carus, Wilson, Marsh, Groom and Bourne.

CORRESPONDENCE.

A BIBLIOGRAPHY OF SCIENTIFIC LITERATURE.

TO THE EDITOR OF SCIENCE: With your permission, I will make a few observations on a plan which I have been steadily working out for the last 35 years, more especially as it embodies many of the suggestions which have recently been made by some of your correspondents. It embraces:

1. A *Bibliography* classified according to subjects arranged: (1) according to the year of publication, and (2) alphabetically under each year according to the name of the author; each item has its distinctive number for reference purposes.

2. An *Index*, which, although arranged alphabetically, is classified in groups more than is usual in an index, the object being to render it possible, at some future time, to amalgamate the various subject indexes into one general classified index.

3. A *Systematised Collocation of Facts* grouped according to their relationship to each other. The aim of the whole is to enable any person engaged in scientific research to find the information he seeks with a minimum expenditure of trouble, time and cash.

In its entirety the idea is thoroughly Utopian; nevertheless, I feel very confident that if only partially carried out it would

afford considerable assistance to many workers.

The method pursued has been to take up literary items in succession, be it a paper, a volume or a series of volumes (for a plentiful supply of which I am indebted to many of your countrymen), to thoroughly analyze the contents and to place the data under their appropriate headings, care being taken to eliminate all useless repetition. As the subject-matter is divided up into a very large number of headings, the result is the focalization of the data in a systematic sequence, so as to bring into close contiguity the facts bearing on the headings which were originally widely scattered in scientific literature.

The generical idea is simple enough, but the practical realisation of it is sometimes attended by many difficulties, and involves a great multiplicity of details which can not be described in the limits of a letter; but some notion may be formed of the scope and extent of what has been done, if a summary is given of the matter already collected under the heading 'Animalia: General.'

The *Bibliography* arranged chronologically by years and alphabetically by authors' names subordinate to the year, at present numbers between 30,000 and 40,000 titles on about 5,000 slips. *General*; for notes of the most general kind, or of an indefinite character; this covers about 50 slips. *Descriptive*; about 30 slips. *Classification*; about 100 slips, arranged chronologically by years, a remark which applies to all headings. *Affinities*; about 70 slips. *Characters*; about 200 slips; arranged by groups (Class, order, etc.) *Organic grade*; about 3,600 slips. This is an attempt to arrange all groups according to their apparent grade on an organic scale, in which the lowest animal is considered to be 1, and the highest 1,000,000. I believe there is a certain amount of novelty in the idea of numeri-

cally externating organic grade, and therefore I venture to make an extract from the slip which refers to the grade range 55,001-56,000. This is considered to be the highest limit of the sub-kingdom *Protozoa*. The class *Infusoria* and the order *Ciliati* extend through it and terminate with it. The following families are comprised in it:

Oxytrichina, 55,001-55,100.

Urocentrina, 55,101-55,550.

Vorticellina, 55,551-56,000.

The following genera are comprised in it:

Stylochæta, 55,001-55,033.

Oxytricha, 55,034-55,100.

Urocentron, 55,200-55,300.

Trichodinopsis, 55,551-55,584.

Spirochona, 55,585-55,618.

Trichodina, 55,619-55,642.

Lagenophrys, 55,643-55,676.

Vaginicola, 55,677-55,710.

Cothurnia, 55,711-55,744.

Ophrydium, 55,745-55,789.

Gerda, 55,790-55,824.

Seyphidia, 55,825-55,859.

Epistylis, 55,860-55-894.

Zoothamnium, 55,895-55,929.

Carchesium, 55,930-55,964.

Verticella, 55,965-56,000.

It is not supposed for one moment that these figures have any claim to strict scientific accuracy. In this respect they are equal in value with the classification on which they are based; their special advantage is that they enable a person to give definiteness to his views as to the position of any form, and hence afford a ready means of comparing any number of different views. For instance, if Rolleston's classification were adopted, the apparent place of *Verticella* would be at about 142,800. This not only shows a difference of opinion, but also the extent of it; this definiteness is calculated to be of great advantage in carrying on discussion.

Systemic: general; about 500 slips.

Systemic : general : Chemical substances ; about 3,000 slips.

There is, I think, a certain amount of novelty in the mode of grouping under this heading, but it would occupy too much space to draw any further attention to this feature. Under this heading each substance found in the bodies of animals has its own set of slips. Particulars are entered bearing upon its chemical composition, chemical constitution, the processes of formation (actual and hypothetical), the changes which it undergoes in the animal body, and (in a general way) its modes of occurrence in the different systems of organs. The full details are given in connection with each organic system.

Under Systemic: General; there are also grouped, the notes relating to *Development, Cells* and their differentiated parts, each part having its own set of slips. *Chondroites, Cilia, Animal Magnetism, Animal Electricity*, and a few other minor subheadings; these cover about 100 slips. *Absorbent System*; this covers about 250 slips, and is broken up into various subheadings subordinate to *Lacteal* and *Lymphatic Subsystems. Alimentary System*; about 1,500 slips. Each particular part has its own set of slips. Under *Bile* each chemical substance found therein has a special set of slips devoted to it; at present there are 65 such substances dealt with in the notes. Under *Food*, also there are a number of subordinate headings: *Circulatory System*, about 1,200 slips. *Generative System*; about 200 slips. *Glands*; about 700 slips. *Muscular System*; about 500 slips. *Nervous System*; about 900 slips. *Osseous System*; about 800 slips. *Respiratory System*; about 300 slips. *Senses*; about 500 slips. *Tegumentary System*; about 300 slips. *Tissues*; about 500 slips. *Urinary System*; about 600 slips. *Habits*; about 150 slips. *Medial Influence*; about 3,200 slips. *Geological Distribution*; about 2,500 slips. This is arranged by periods, and under each period there

are separate sets of slips for each country or subdivision of a country, such as county, etc. *Geographical Distribution*; about 400 slips.

The whole number of slips relating to animals regarded from a general point of view is about 27,000.

Each class of animals has separate treatment, the facts being mostly grouped together under the main headings above enumerated for animals in general, subordinated to the name of each genus.

Notes have been collected more or less fully under most of the classes, so that few comprise less than 5,000 or 6,000 slips, while some comprise a great many more than that.

The notes under some of the non-zoölogical subjects are also more or less bulky. Thus *Stratigraphy, Minerals* (including chemical substances), *Ocean, Water* and some others each exceed 30,000 slips.

The slips I use measure eight inches by five inches, and are arranged in book boxes lettered on the back with the name of the subject-matter in the box. Each slip is headed with all the main and subordinate headings appertaining to it and numbered. By taking care that the size is kept uniform there is little risk of the edges being turned back, of the corners being dog-eared, or of the surfaces becoming dusty or soiled. They have all the advantages of cards, occupy much less space and are more easily handled, as each book box is the size of a thick octavo volume.

In conclusion, I wish to thank you for allowing me to occupy so much of your space.

A. RAMSAY.

LONDON.

HACK TUKE MEMORIAL.

The great respect in which the late Dr. D. Hack Tuke was held by all who knew him has led to a very generally expressed desire that his memory should be perpetuated in connection with the great work to which

he devoted his life, viz., the amelioration of the condition of the insane, and the progress of neurological and psychological medicine.

With the view of carrying out this object, an influential and representative committee has been appointed, and they are of opinion that the memorial should take the form of a prize or medal to be awarded as an encouragement to the study of the above-mentioned subjects.

The committee venture to make an earnest appeal to all those who desire to honor the memory of Dr. Tuke and to promote his life's work, for subscriptions to carry out this object.

The subscriptions may be sent to the Honorary Treasurer, Henry Rayner, M. D., 2 Harley street, London, W.

G. F. BLANDFORD, M. D.,
Chairman.

SCIENTIFIC LITERATURE.

L'Année psychologique. Première Année, 1894. Publiée par MM. H. BEAUNIS et A. BINET. Alcan, Paris, 1895. Pp. vii., 619. 10 francs.

This new annual combines two main features, both of which will prove of interest and value to psychologists: it publishes the results of the investigations undertaken at the psychological laboratory of the Sorbonne, together with some other original articles, and a general review on some important question; and it gives an extended analysis and bibliography of all the important psychological literature which appeared in 1894. With the largely increasing mass of literature appearing in this field, the latter feature will render the annual extremely helpful. As to the original matter, every one who is familiar with the previous work of M. Binet, the director of the laboratory, will be assured beforehand of its high quality, its thoroughness and its insight.

I. After a brief introduction by M. Beau-

nis, we find the original articles occupying in all 255 pages. They are as follows:

(1) A. Binet and V. Henri: *Memory for Words* (Pp. 1-23). The number of isolated words retained after a single hearing varies with age and with the number of words heard; only one-third to one-half as many are preserved in memory as can be repeated immediately after hearing them read; the first and the last words heard are the ones best retained; in immediate repetition, errors of sound, and in later repetition, errors of sense predominate. Errors of omission are much more numerous than errors of imagination, where for one word is substituted another entirely different. The principles of contiguity and of resemblance are not sufficient to account for the recall of particular words; the direction of the attention towards the experiment as a whole is a further essential condition.

(2) A. Binet and V. Henri: *Memory for Phrases* (for ideas). (Pp. 24-59). The number of words retained was found, under the conditions of the experiment, to be about 25 times as great when they occur in connected phrases as when they are isolated.

(3) A. Binet and J. Passy: *Psychological Studies of Dramatic Authors*. (Pp. 60-119). This paper gives the results of an attempt to throw light on the question of the creative imagination by means of interviews with Victorien Sardou, Alexandre Dumas, Alphonse Daudet, Edouard Pailleron, Henry Meilhac, Edmond de Goncourt and François Coppée. The following results were attained: (1) The work of literary composition does not manifest itself in any exceptional physical or moral condition distinguishing it from other mental occupations. The belief in an 'artistic hallucination,' as well as in the importance of the influence of the seasons, of the environment, of artificial excitants, is unfounded. The work of artistic creation demands full

self-possession, and depends not only on the imagination, but also on reason and common sense. (2) The sole effective excitation to work is of psychological nature; the author finds himself in a particular emotional state, which originates directly in the subject treated. (3) The work of dramatic composition takes place most frequently under the form of crises—longer or shorter periods during which production is especially easy. (4) As to the mental state during composition, the author may simply attribute to his characters his own ideas and emotions; he may seek to forget his own personality, and to enter into that of the characters he imagines; or he may be in a state which may be truly called one of inspiration, where he seems to listen passively to the conversation which his characters themselves carry on. (5) With few exceptions, the professional dramatic authors, when they compose, represent the scene to themselves as occurring on the stage of a true theatre. (6) The question of mental images is one of little importance in composition.

(4) A. Binet: *François de Curel* (pp. 119–173). This paper continues the previous one, and is given separately because the observations furnished by Mr. de Curel are so abundant and so precise as to constitute probably the most complete analysis in existence of the creative imagination. M. de Curel's mental state during composition is of the third type mentioned in the previous paper, that of inspiration.

(5) Weeks: *Experimental Researches in Phonetics* (pp. 174–178). Contrary to the received opinion the South German consonants b, d, g, whether at the beginning, in the middle, or at the end of a word, are weaker than p, t, k, instead of identical with them.

(6) Th. Flournoy: *The Action of the Environment on Ideation* (pp. 180–197). Forty-three persons each drew ten designs

and wrote ten isolated words. The immediate environment was responsible for 15.7% of the drawings, 37.2% of the words; individual habits, profession, etc., accounted for 41.6% of the designs, 31.1% of the words.

(7.) Th. Flournoy: *A case of personification*. (Pp. 191–197.) A rare phenomenon, similar in nature to colored hearing, visual schemes, etc. It consists in the concrete representation of a person (or animal or object) regularly aroused by a word or an idea which has no comprehensible relation with this associated image.

(8.) Th. Flournoy: *The influence of the visual perception of bodies on their apparent weight*. (Pp. 198–208.) Smaller objects of equal weight seem heavier than the larger if they are looked at while the comparison takes place. The illusion persists, even when the equality of weight is known, and does not depend on the mode of prehension or upon inequalities of cutaneous contact. Of two equal weights occupying a volume of 2100 and 10 cm. respectively, the smaller was judged to be from two to five times as heavy as the larger. This experiment proves that the sensation of motor effort is purely kinesthetic, and that so-called sensations of innervation have no existence.

(9.) E. B. Delabarre: *The Laboratories of Psychology in America*. (Pp. 209–255.) A brief account of the development of Psychology in America is followed by a detailed description of the psychological laboratories. These number 27, of which 8 or 9 are for demonstration only; some 5 to 8 devote some attention also to research; and 10 or more are especially active in research. In connection with each laboratory are given the names of director and instructors; list of courses; date of establishment of the laboratory, number of rooms occupied, value of equipment and annual appropriation, and kind of research for

which it is especially fitted; library facilities; scholarships and fellowships open to students; lists of apparatus invented, researches published and in preparation, and other publications by the instructors.

II. The second part of the *année* is headed 'Bibliographie,' and consists of analyses of nearly 200 books and articles (pp. 257-528), of a description of new apparatus (529-534), and of a necrology (535-538).

III. In a third part is placed a bibliographical table of 1217 titles, provided with an index of authors. The classification of this bibliography, which differs slightly from that of the analyses of the second part, is the following: Psychological treatises; articles on general psychology; normal and pathological anatomy and histology of the central nervous system; physiology of the nervous system; psychological methods; physiology and anatomy of vision; visual sensations; audition; sensations of the skin; gustatory and olfactory sensations; movements; fatigue; emotions; memory; psychometry; attention; association; individual psychology and character; scholastic psychology (pedagogy); heredity and evolution; criminal psychology; hypnotism, suggestion and sleep; aphasia; mental and nervous pathology; anthropology; comparative psychology.

The first five articles of part I. do not represent all the work accomplished in connection with the laboratory of the Sorbonne. A full list, given on p. 179, includes twelve further titles of papers which have been published elsewhere, and which are therefore merely analyzed in part II. It is proposed to retain as a permanent feature of the *Année* the 'general review on some important question,' represented this year by the paper on American laboratories, in such a manner as to gradually work through the entire field of psychology. General reviews on psychometry, on the graphic

method, and on the psychology of vision, are announced as probable.

E. B. DELABARRE.

BROWN UNIVERSITY.

Iowa Geological Survey. SAMUEL CALVIN, State Geologist. Volume III. being the Second Annual Report (1893) and accompanying papers. Des Moines, 1895, pp. 501, plates XXXVII., figs 34.

In July, 1892, the present Geological Survey of Iowa took the field, and up to date three volumes have been issued. These are the Annual Report for 1892, issued 1893; the Coal Deposits of Iowa, issued 1894; and the Annual Report for 1893, the volume here under consideration. Iowa is more widely known for its agricultural than for its mineral resources, but the latter are none the less of extreme importance. In coal there is a vast productive area and an annual output of five million tons. The great beds of gypsum near Fort Dodge are now being adequately developed, and in not a few places throughout the State the less conspicuous industries of brick, pottery and building stone are coming into prominence. It is not intended to imply that agriculture is in any degree less benefited by a geological survey than these other industries, and the reports in question give evidence that this fact has been well appreciated by the State Geologist. The wise manager in an office of this kind carries on, behind the breastworks of economic geology, all the purely scientific work that his constituency will bear. Professor Calvin seems to have nicely adjusted these relations.

Passing over the routine reports, the work before us contains the following special papers:

H. F. Bain describes the 'Cretaceous Deposits of the Sioux Valley,' pp. 101-114. The classification of the cretaceous is more accurately carried out for this region than

had been previously done, and the importance of this formation in Iowa, a fact that we are just beginning to appreciate, is still further brought out.

W. H. Norton, 'Certain Devonian and Carboniferous Outliers in Eastern Iowa,' pp. 117-133. Both these formations are represented east of their main areas, but whether the outliers have or have not been cut off by erosion is still undecided.

J. L. Tilton, 'Geological Section along Middle River in Central Iowa,' pp. 137-146.

C. R. Keyes, 'Glacial Scorings in Iowa,' pp. 149-165. The paper describes and tabulates striae in all four quarters of the State. The general directions are between south and east.

W. H. Norton, 'Thickness of the Paleozoic Strata of Northeastern Iowa,' pp. 169. This important paper is based on well records obtained from holes sunk both for water and oil or gas. These valuable records are usually so evanescent that to have so many preserved is a matter of congratulation.

C. R. Keyes, 'Gypsum Deposits of Iowa,' pp. 259-304. This report is a welcome addition to the scanty literature of an important industry. Iowa is now fourth among the States as a producer of plaster and has great reserves of the crude rock for the future.

C. R. Keyes, 'Geology of Lee County,' pp. 307-407. Lee county forms the southeastern corner of the State. The paper reviews its geology with thoroughness and with good illustrations.

C. R. Keyes, 'Economic Geology of Des Moines County,' pp. 411-492. This county adjoins Lee on the north. After an introductory geological sketch, the building stones, clays, coal and other minor economic minerals are taken up.

The typography and general style of the volume are excellent and reflect credit on the management of the Survey. Since its issue Dr. C. R. Keyes has become State

Geologist of Missouri, and H. F. Bain has become Professor Calvin's chief assistant, making thus some recent changes of personnel in the staff. J. F. KEMP.

HYGIENE.

Annual report of the Department of Health of the City of Chicago for the year ended December 31, 1894. ARTHUR R. REYNOLDS, M. D., Commissioner of Health, Chicago. 1895. 268 pp., 8°.

Dr. Reynolds remarks that "the phenomenal healthfulness of the city continues to be the theme of incredulous comment by less favored localities." When a death rate of 15.24 per 1,000 is reported for a city of a million and a half of people it is very apt to be the subject of incredulous comment by statisticians, who are skeptical about municipal death rates of less than 17 per 1,000, knowing that there are several ways of lowering death rates besides the primitive one of reducing the number of deaths. It is clear, however, that there were but 23,892 deaths reported in Chicago during the year 1894 as against 27,083 in 1893; 26,219 in 1892, and 27,754 in 1891, and that, therefore, the death rate must have been comparatively low last year, as it was in almost all large cities.

The account of the small pox epidemic is interesting. 2332 cases were received in the city small pox hospital. 993 of these had been vaccinated after some fashion, and of these 161, or 16.2 per cent., died. 1339 had not been vaccinated, and of these 485, or 36.2 per cent., died. The difference was most marked in the children under 6 years of age, in whom the mortality of those vaccinated was 12.5, and of those unvaccinated 44.0 per cent. The chronological summary of Chicago mortality from 1851 to 1894, with diagrams, is interesting and valuable. The report, as a whole, contains a vast amount of information and is highly creditable to the department which issues it.

Handbook of Sanitary Information for Householders. By ROGER S. TRACY, M. D., 114 pp., 16°. New York, D. Appleton & Co. 1895. Price, 50 cents.

This little book is intended especially for the information of householders in the city of New York, and is, in most respects, well adapted to its purpose. The section on house plumbing is the fullest and best. The section on disinfection is behind the times by about 12 years; sulphate of iron is not now considered to be a disinfectant, but merely a deodorant, and no allusion is made to the disinfectants now most relied upon, viz.: chloride of lime, mercury bichloride and carbolic acid.

The warning against inhaling the breath of persons affected with diphtheria and consumption is unnecessary, and diverts attention from the real source of danger, which is correctly stated to be the discharges from the throat, nose and lungs. There are no bacteria, specific or other, in the expired breath in ordinary respiration.

SCIENTIFIC JOURNALS.

THE AMERICAN GEOLOGIST, JULY.

Remarks on the Genus Nanno, Clark. By ALPHEUS HYATT.

This interesting genus of cephalopods was first described by Professor J. M. Clarke (*Am. Geol.*, Oct., 1895). The present author has made a more extended and detailed study of the type specimens, which were from the Lower Silurian of southeastern Minnesota. The paper is accompanied by a half-tone plate showing several sections of the fossils.

Steps of Progressive Research in the Geology of the Lake Superior Region prior to the late Wisconsin Survey. By N. H. WINCHELL.

This paper is the fifth in a series entitled 'Crucial Points in the Geology of the Lake Superior Region.' Beginning with the Canadian Geological Survey, the vari-

ous steps of progress are traced down to the commencement of the Wisconsin Survey. Among other things the origin and use of the term Huronian is explained and some misapplications of that term are noticed.

Actinophorus Clarki, Newberry. By E. W. CLAYPOLE.

The discovery of another specimen of this fossil fish by Dr. Clarke, of Berea, Ohio, after whom the fish was named, has furnished Professor Claypole with data for a more complete description than was possible when the type was first described by Professor Newberry.

Camptonites and other Intrusives near Lake Memphremagog. By V. F. MARSTERS.

Quite a number of dykes, both granitic and lamprophyric, have been found on the shores of this lake. The following lamprophyre dykes are described: Diabase, camptonite, augite camptonite, monchiquite and fourchite. An important feature of the paper is a summary of the literature on other occurrences of monchiquite and camptonite.

The Kame-Moraine at Rochester, N. Y. By H. L. FAIRCHILD.

The Pinnacle hills, at Rochester, with which this paper deals, have long been known to glacialists, but no detailed description of them and of their origin has before been attempted, except by Mr. Warren Upham, who regards them as of the nature of eskers. Professor Fairchild has lately investigated these hills, and the present paper is a rather complete abstract of the results of this investigation, which will be published in full in the Proceedings of the Rochester Academy of Science. He regards these hills as constituting a kame series forming part of a frontal moraine.

Under 'Editorial Comment' a considerable review of the present status of the feldspars is given, and the results of the recent optical work of Messrs Michel-Lévy and La Croix is brought forward. Under 'Corre-

spondence' Dr. Geo. M. Dawson presents a note on 'Interglacial Climatic Conditions.' This number includes the usual reviews of recent geological literature, list of recent publications, and personal and scientific news.

THE MONIST, JULY.

THE opening article by Professor Joseph Le Conte, *The Theory of Evolution and Social Progress*, reviews broadly the history of the development-idea and finds that there are four grades or planes of evolution—physical, chemical, biotic and human. To each there is a limit, and the evolutionary process can continue only by being transferred to a higher grade with new factors. The first three have already reached their goals; only the last, rational evolution, remains. Here the significance and character of the new factor—voluntary rational coöperation—which differentiates the new grade from the rest, must be considered in sociological applications. Professor Le Conte emphasizes the beneficent and encouraging features of the Lamarckian factors, and counsels strict subordination to wise empiricism in all practical applications of scientific principles.

In *The Present Problems of Organic Evolution*, Professor E. D. Cope, after stating *ipsisimis verbis* the views of Lamarck, Darwin, Wallace, Spencer, Haeckel, Weismann and others, contrasts the doctrines of the two opposed schools of epigenesis and preformation, and sketches the main features of his own theory of the origin and inheritance of variations as based on independent studies, to be developed in full in a forthcoming book.

The Metaphysical X in Cognition, a long and exhaustive article by Dr. Paul Carus, examines and aims to refute the theory of knowledge, now almost universally accepted, which rejects scientific explanation as the ultimate term of cognition, and which finds in science an unknowable metaphys-

ical residuum which the human mind can never hope to compass. Dr. Carus also examines the view of Professor Ernst Mach that ultimate explanations in physics are not necessarily mechanical explanations.

Professor A. E. Dolbear, in *Materialism Untenable*, points out that the possibilities of matter as an active agent are not yet limited. In *The Unseen Universe* Sir Robert Stawell Ball develops in a popular but elegant manner the truth that the objects which we can see in the heavens very probably constitute not a millionth part of the material universe.

In *The Science of Mentation*, Mr. Elmer Gates propounds 'some new general methods of psychologic research.' Mr. Gates lays stress on the results which he has reached by the *artificial* variation (1) of the organic structures and (2) of the mentation of organisms. His color experiments with dogs kept in the dark from their birth and with dogs compelled to distinguish between colors by electric shocks consequent upon certain actions, with the structural results shown by cerebral dissection, are ingenious. The educational inferences of this article, although sweeping, are suggestive.

Mr. E. Douglas Fawcett writes on monadology, and Mrs. Emilia Digby in refutation of the onomatopie theory of music. M. Lucien Arreat's letter on the philosophical literature of France, with reviews of the best and most recent philosophic, scientific and religious works published in America, England, Germany and Italy, constitute the rest of the contents.

NEW BOOKS.

Biological Lectures delivered at the Marine Biological Laboratory of Wood's Holl. Boston, Ginn & Co. 1895. Pp. vii+287.

Analytical Chemistry. N. MENSCHUTKIN. Translated by JAMES LOCKE. London and New York, Macmillan & Co. 1895. Pp. xii+512. \$4.00.

SCIENCE.

A WEEKLY JOURNAL DEVOTED TO THE ADVANCEMENT OF SCIENCE.

TERMS OF SUBSCRIPTION.

Five dollars annually in advance: single copies 15 cents. Subscriptions and advertisements should be sent to SCIENCE, 41 North Queen Street, Lancaster, Pa., or 41 East 49th Street, New York.

Foreign subscribers may send their subscriptions direct (\$5.00), or may subscribe and order single numbers through Gustav E. Stechert, London: 30 Wellington Street, Strand, W. C. (£ 1-0-6, single copies 8d). Paris: 76 Rue de Rennes (26 fr., single copies 80c). Leipzig: 10 Hospital Strasse (M. 21, single copies 70 Pf).

The publisher can supply back volumes of SCIENCE at the regular subscription rates, or for one dollar in addition, if bound. Single copies of nearly all the numbers can also be supplied at the price of 25 cents for numbers earlier than July, 1887, or 15 cents for later numbers.

ADVERTISEMENTS.

Terms may be obtained from the publishers.

Advertisements of scientific publications, scientific apparatus and educational institutions are desired as part of the work of the journal. There is no other journal published in America that reaches more directly those who use and recommend scientific books and apparatus.

The Contents and Index of Volume I. are sent out with the present Issue.

The Journal of Comparative Neurology,

Edited by

C. L. Herrick and C. Judson Herrick.

Devoted to the comparative study of the nervous system in all of its aspects. Original papers on nervous structure and function, comprehensive and critical reviews and full abstracts of current literature, and a quarterly bibliographical index of the neurological literature of the world are regular features.

Abundant illustrations are furnished, each volume thus far issued containing from 20 to 28 plates.

Published quarterly at \$3.50 per annum, to all countries in the postal union.

Published by the Editors at

Denison University,
Granville, Ohio.

THE POPULAR SCIENCE MONTHLY

For June.

From the Divine Oracles to the Higher Criticism. I. The Older Interpretation.

By ANDREW D. WHITE, LL. D., Ph. D.

Presents some of the mystical and fantastic interpretations of the Scriptures current in the Middle Ages, with notes on the beginnings of modern textual criticism.

Professional Institutions. II. Physicians and Surgeons.

By HERBERT SPENCER.

Traces the evolution of these professions from the functions of the primitive medicine-man, with a wealth of evidence and illustration.

The Psychology of Woman.

By PROF. G. T. W. PATRICK.

A detailed statement of the peculiarities of women's minds, including many comparisons with the minds of men.

Journeying in Madagascar.

By FRANK VINCENT. Illustrated.

A glimpse at a strange land, now the scene of a French colonial war.

OTHER ARTICLES BY

BARTON W. EVERMANN, Ph. D. (Illustrated), H. T. NEWCOMB, GARRETT P. SERVISS (Illustrated), D. T. MACDOUGAL (Illustrated), A. B. RONNE (Illustrated), FANNY D. BERGEN and DR. CHARLES C. ABBOTT.

CORRESPONDENCE; EDITOR'S TABLE; LITERARY NOTICES; POPULAR MISCELLANY; NOTES.

50 CTS. A NUMBER. \$5.00 A YEAR.

D. APPLETON & Co.,
NEW YORK.

Walker Prizes in Natural History.

By the provisions of the will of the late Dr. William Johnson Walker, two prizes are annually offered by the BOSTON SOCIETY OF NATURAL HISTORY for the best memoirs written in the English language on subjects proposed by a committee appointed by the Council.

For the best memoir presented, a prize of sixty dollars may be awarded; if, however, the memoir be one of marked merit, the amount may be increased to one hundred dollars, at the discretion of the committee.

For the next best memoir, a prize not exceeding fifty dollars may be awarded.

Prizes will not be awarded unless the memoirs presented are of adequate merit.

The competition for these prizes is not restricted, but is open to all.

Attention is especially called to the following points:—

1. In all cases the memoirs are to be based on a considerable body of original and unpublished work, accompanied by a general review of the literature of the subject.
2. Anything in the memoir which shall furnish proof of the identity of the author shall be considered as debarring the essay from competition.
3. Each memoir must be accompanied by a sealed envelope enclosing the author's name and superscribed with a motto corresponding to one borne by the manuscript, and must be in the hands of the Secretary on or before April 1st of the year for which the prize is offered.

SUBJECTS FOR 1896:—

- (1) A study of an area of schistose or foliated rocks in the eastern United States.
- (2) A study of the development of river valleys in some considerable area of folded or faulted Appalachian structure in Pennsylvania, Virginia or Tennessee.
- (3) An experimental study of the effects of close-fertilization in the case of some plant of short cycle.
- (4) Contributions to our knowledge of the general morphology or the general physiology of any animal, except man.

SUBJECTS FOR 1897:

- (1) A study of glacial, fluvial, or lacustrine phenomena associated with the closing stages of the glacial period.
- (2) Original investigations in regard to the chalazal impregnation of any North American species of Angiosperms.
- (3) An experimental investigation in cytology.
- (4) A contribution to our knowledge of the morphology of the Bacteria.

SAMUEL HENSHAW,

Secretary.

Boston Society of Natural History,
Boston, Mass., U. S. A.

SCIENCE

NEW SERIES.
VOL. II. No. 29.

FRIDAY, JULY 19, 1895.

SINGLE COPIES, 15 CTS.
ANNUAL SUBSCRIPTION, \$5.00.

GUSTAV E. STECHERT'S

Recent Importation of Scientific Books.

BEBBER, DR. W. J. von. Hygienische Meteorologie. Für Aerzte und Naturforscher. Mit 42 in den Text gedruckten Abbildungen. 8°. M. 8.

BERGH, DR. R. S. Vorlesungen über allgemeine Embryologie. Mit 126 Figuren im Text. 289 Seiten. Gross 8°. M. 7.

DAMMER, DR. O. Handbuch der chemischen Technologie. Unter Mitwirkung von Th. Beckert, Dr. Bender, Dr. Benedict, Dr. Börnstein, u. A. Band I. Mit 191 in den Text gedruckten Figuren. gr. 8°. M. 24.

HANDWÖRTERBUCH DER ASTRONOMIE, Unter Mitwirkung mehrerer Professoren, herausgegeben von Prof. Dr. W. Valentiner. Mit Abbildungen. Lieferung 1. 128 Seiten. Gross 8°. M. 3.60.

HARTLEBEN'S statistische Tabelle über alle Staaten der Erde. Uebersichtliche Zusammenstellung von Regierungsform, Staatsoberhaupt, Thronfolger, Flächeninhalt, absoluter und relativer Bevölkerung, Staatsfinanzen, Handelsflotte, Handel, Eisenbahnen, Telegraphen, Zahl der Postämter, Werth der Landesmünzen in deutschen Reichsmark, Gewichten, Längen und Flächenmassen, Hohlmassen, Armee, etc. M. 50Pf.

VON JONSTORFF, HANNS FREIHERR JÜPTNER. Fortschritte im Eisenhütten-Laboratorium in den letzten 10 Jahren. Erster Band. Mit 99 Figuren. 270 Seiten. 8°. M. 8.50.

KOLBE, BRUNO. Einführung in die Electricitätslehre. Band II. Dynamische Electricität. Mit 75 in den Text gedruckten Holzschnitten. 187 Seiten. 8°. M. 3.

KRÄMER, INGENIEUR JOS. Wirkungsgrade und Kosten elektrischer und mechanischer Kraft-Transmissionen. Mit vielen Figuren, Schemas und einer Tafel. 88 Seiten. 8°. M. 3.

LEDUC, A. Manipulations de Physique Avec. 144 figures intercalées dans le texte. 392 pages. 8°. Fr. 6.

MEISSNER, G. Die Hydraulik und die hydraulischen Motoren. Ein Handbuch für Ingenieure, Fabrikanten und Constructeure. Zum Gebrauche für technische Lehranstalten sowie ganz besonders zum Selbstunterricht. Zweite vollständig neu bearbeitete Auflage von Dr. H. Hederich und Ingenieur Nowak. I. Band. Die Hydraulik. Lieferung 1. 80 Seiten. 8°. M. 3.

MEYER, PROF. DR. ARTHUR. Untersuchungen über die Stärkekörner. Wesen und Lebensgeschichte der Stärkekörner der höheren Pflanzen. Mit 9 Tafeln und 99 in den Text gedruckten Abbildungen. 320 Seiten. Gross 8°. M. 20.

METZGER, PROF. DR. A., und **PROF. DR. N. I. C. MÜLLER,** Die Nomenclaure und ihre Bakterien Untersuchungen ausgeführt in den zoologischen und botanischen Instituten der Königl. preuss. Forstakademie Münden. Mit 45 of Tafeln in Farbendruck-160 Seiten. 8°. M. 16.

MICHAUT, L. ET M. GILLET. Leçons élémentaires de télégraphie électrique. Système Morse-Manipulation-Notions de Physique et de Chimie-Piles-Appareils et accessoires installation des postes. 2^e édition, entièrement refondue. 232 pages. Pet. 8°. Fr. 3.75.

NI EWENGLOWSKI, PROF. B. Cours de Géométrie Analytique a l' usage des élèves de la classe de mathématiques spéciales et des candidats aux écoles du gouvernement. Tome II. Construction des Courbes planes. Compléments relatifs aux coniques. 292 pages. 8°. Fr. 8.

PRASCH, ADOLF AND HUGO WIETZ. Die elektrotechnischen Maasse. Lehrbuch zum Selbststudium. Dargestellt und durch zahlreiche Beispiele und 38 in den Text gedruckte Figuren erläutert. 153 Seiten. 8°. M. 3.00.

SCHMIDT, DR. F. W. Kurzes Lehrbuch der anorganischen Chemie. Ein Repetitorium für Chemiker, Mediciner und Pharmaceuten. 376 Seiten. 8°. M. 4.50.

VERWORN, DR. MAX. Allgemeine Physiologie. Ein Grundriss der Lehre vom Leben. Mit 270 Abbildungen. 584 Seiten. gr. 8°. M. 15.

WASMANN, E. Kritisches Verzeichniss der Myrmekophilen und Termitophilen Arthropoden. Mit Angabe der Lebensweise und mit Beschreibung neuer Arten. 231 Seiten. gr. 8°. M. 12.

WINDRATH, DR. A. Die Medicin unter der Herrschaft des bacteriologischen Systems. 231 Seiten. 8°. M. 5.

WYSS, DR. HANS, V. Kurzes Lehrbuch der Toxicologie für Studierende der Medicin und praktische Aerzte. 219 Seiten. gr. 8°. M. 5.

WISLICIENUS, PROF. DR. WALTER F. Astronomische Chronologie. Ein Hülfsbuch für Historiker, Archäologen und Astronomen. 163 Seiten. 8°. Leinwandband. M. 5.

ZICKLER, PROF. KARL. Das Universal-Elektrodynamometer. Mit 8 in den Text gedruckten Figuren. 32 Seiten 8°. M. 1.

GUSTAV E. STECHERT,
810 Broadway, New York.

Macmillan & Co.'s New Publications.

Cambridge Natural Science Manuals. General Editor—A. E. SHIPLEY, M. A.
Fellow and Tutor of Christ's College.

NEW VOLUMES.

- I. **Elements of Botany.** By F. DARWIN, M. A., F. R. S., Fellow of Christ's College, Cambridge, and Reader of Botany in the University. With numerous illustrations. 12mo, \$1.60 *net.* (*Biological Science.*)
- II. **Petrology for Students.** By A. HARKER, M. A., F. G. S., Fellow of St. John's College, Cambridge University Demonstrator in Petrology. 12mo, \$2.00.
- III. **A Text-Book of Zoögeography.** By FRANK E. BEDDARD, M. A. (Oxon.), F. R. S., Professor of the Zoölogical Society of London. Maps, 12mo, cloth, \$1.60, *net.* (*Biological Science.*)

The Theory of Light. By THOMAS PRESTON, M. A. (Dub.), Fellow of the Royal Society of Ireland and Professor of Natural Philosophy, University College, Dublin. 8vo, cloth, pp. xii+573, \$5.00, *net.*

Analytical Chemistry. By N. MENSCHUTKIN, Professor of the University of St. Petersburg. Translated from the third German Edition under the supervision of the Author. By JAMES LOCKE, Assistant in the Analytical Laboratory of the University of Heidelberg. Pp. xii+512, 8vo, cloth, \$4.00, *net.*

Text-Book of Operative Surgery. By DR. THEODOR KOCHER, Professor of Surgery and Director of the Surgical Clinic in the University of Bern. Translated with the Special Authority of the Author from the Second Revised and Enlarged German Edition by HAROLD J. STILES, M. B., F. R. C. S., Edin., Senior Demonstrator of Surgery and formerly Demonstrator of Anatomy in the University of Edinburgh, etc. With 185 Illustrations. 8vo, cloth, pp. 303, \$3.50, *net.*

On certain Phenomena belonging to the Close of the Last Geological Period, and on their bearing upon the Traditions of the Flood. By JOSEPH PRESTWICH, D. C. L. (Oxon.), F. R. S., F. G. S., Corr. Inst. France (Acad. Sc.), Acad. R. Lyncei, Rome; Roy. Acad., Brussels, etc. 8vo, cloth, pp. 87, \$1.00.

The Horticulturist's Rule-Book. A Compendium of Useful Information for Fruit-growers, Truck-gardeners, Florists and others. By L. H. BAILEY, Professor of Horticulture in Cornell University. Third Edition, thoroughly Revised and Recast, with many Additions. 12mo, limp cloth, 75 cents.

Hydrodynamics. By H. LAMB, M. A., F. R. S., Professor of Mathematics in Owens College, Manchester. Demy 8vo, cloth, \$6.25, *net.*

A Monograph on the Order of Oligochaeta. By FRANK EVERS BEDDARD, M. A. (Oxon.), F. R. S., Prosector to the Zoölogical Society of London, and Lecturer at Guy's Hospital. 4to, stiff boards, linen back, \$12.50, *net.*

Crystallography. A Treatise on the Morphology of Crystals. By N. STORY-MASKELYNE, M. A., F. R. S., Professor of Mineralogy, Oxford, Honorary Fellow of Wadham College. 12 mo, \$3.50, *net.*

The Great Frozen Land (Bolshaia Zemelskija Tundra). Narrative of a Winter Journey across the Tundras and a Sojourn among the Samoyads. By FREDERICK GEORGE JACKSON, Fellow of the Royal Geographical Society, Leader of the Jackson-Harmsworth Polar Expedition. With Illustrations and Maps. Edited from his Journals by ARTHUR MONTEFIORE, Fellow of the Geological and Royal Geographical Societies and Anthropological Institute. 8vo, cloth, pp. 297, \$4.50.

The American Commercial Policy. Three Historical Essays. By UGO RABBENO, Professor of Political Economy in the University of Modena. Second Edition. Partly rewritten and entirely revised by the author. Translated at the Translations Bureau, London. 8vo, cloth, pp. 414, \$3.25, *net.*

MACMILLAN & CO., 66 Fifth Avenue, New York.

SCIENCE

EDITORIAL COMMITTEE: S. NEWCOMB, Mathematics; R. S. WOODWARD, Mechanics; E. C. PICKERING, Astronomy; T. C. MENDENHALL, Physics; R. H. THURSTON, Engineering; IRA REMSEN, Chemistry; J. LE CONTE, Geology; W. M. DAVIS, Physiography; O. C. MARSH, Paleontology; W. K. BROOKS, Invertebrate Zoology; C. HART MERRIAM, Vertebrate Zoology; S. H. SCUDDER, Entomology; N. L. BRITTON, Botany; HENRY F. OSBORN, General Biology; H. P. BOWDITCH, Physiology; J. S. BILLINGS, Hygiene; J. MCKEEN CATTELL, Psychology; DANIEL G. BRINTON, J. W. POWELL, Anthropology.

FRIDAY, JULY 19, 1895.

DANIEL CADY EATON.

CONTENTS:

| | |
|--|----|
| <i>Daniel Cady Eaton</i> : N. L. BRITTON..... | 57 |
| <i>The United States Geological Survey</i> | 58 |
| <i>The Biological Experiment Station of the University of Illinois</i> | 62 |
| <i>Atlet Baidarkas in Kamchatka</i> : LEONHARD STEJ- NEGER | 62 |
| <i>The History of Navigation in Spain</i> : JOSEPH DE PERROTT | 63 |
| <i>Current Notes on Anthropology (XL)</i> :—..... | 66 |
| <i>Racial and Ethnic Traits; The Progressive Depopulation of Northern Regions; The Pictographs of Lower California; The Earliest Human Occupants of the Atlantic Watershed</i> : D. G. BRINTON. | |
| <i>Notes on Agriculture (V)</i> :—..... | 68 |
| <i>Native Plums and Russian Cherries; Pineapple Culture; The Flow of Maple Sap; Damping Off</i> : BYRON D. HALSTED. | |
| <i>Scientific Notes and News</i> :—..... | 68 |
| <i>The Congress of Physiologists; Yerkes Observatory; The Royal Astronomical Society; General.</i> | |
| <i>University and Educational News</i> :—..... | 72 |
| <i>Anthropology in Harvard University; Union College; General.</i> | |
| <i>Correspondence</i> :—..... | 74 |
| <i>An International Congress of Bibliography</i> : AKSEL G. S. JOSEPHSON; <i>A Card Catalogue of Scientific Literature</i> : F. B. WEEKS; <i>Volcanic Dust</i> : H. J. HARNLY. | |
| <i>Scientific Literature</i> :—..... | 78 |
| <i>Preyer's Psychologie des Schreibens</i> : PERSIFOR FRAZER. <i>Miall's Aquatic Insects</i> : S. H. S.; <i>Butterflies and Moths of Tenerife</i> : SAMUEL HENSHAW. <i>Morphology of Crystals</i> : A. J. MOSES. | |
| <i>Scientific Journals</i> :—..... | 83 |
| <i>The Astrophysical Journal; The American Naturalist.</i> | |
| <i>New Books</i> | 84 |

DANIEL CADY EATON, long Professor of Botany in Yale College, died at his home in New Haven, Conn., on Saturday, June 29th. He had been ill for many months, and letters received from him during the past winter and spring show that, while he had become much discouraged about his condition, his devotion to his chosen science was unabated.

He was graduated from Yale College in 1857 and from the Lawrence Scientific School of Harvard College in 1860. He subsequently resided in New York City, where he was intimately associated with Dr. John Torrey. He was elected Professor of Botany at Yale in 1864 and occupied the chair until his death, his services to the University having thus extended over more than thirty years.

Professor Eaton's special field of work was in the taxonomy of ferns, mosses and algae, and nearly all his published papers relate to these groups of plants, those on ferns being the most numerous, and through them his name is most widely known. The most extensive of these is his 'Ferns of North America,' published in parts during 1879 and 1880, forming two quarto volumes, illustrated by eighty-one plates. He contributed the descriptions of Filices to Dr. Chapman's 'Flora of the Southern United States' in 1860; of the Acrogens to Dr. Gray's 'Manual of Botany,' fifth edition in

MSS. intended for publication and books, etc., intended for review should be sent to the responsible editor, Prof. J. McKeen Cattell, Garrison on Hudson, N. Y.

Subscriptions and advertisements should be sent to SCIENCE, 41 N. Queen St., Lancaster, Pa., or 41 East 49th St., New York.

1867, and sixth edition in 1890; the treatment of the Compositæ, Filices and Equisetaceæ to Dr. Sereno Watson's 'Botany of King's Expedition' in 1871 and of the Ferns and Higher Cryptogams to the same author's 'Botany of California' in 1880. He was early associated with Dr. W. G. Farlow and Dr. C. L. Anderson in the preparation and distribution of 'Algæ Boreali-Americanae,' the first consecutively numbered sets of North American algæ of any considerable extent that has been issued. Recently his attention has been specifically given to the Sphagna, and in conjunction with Mr. C. E. Faxon he was preparing sets of these plants for distribution, a most important work, which, it is sincerely hoped, will not be suspended on account of his untimely death.

Personally Professor Eaton was generous to a fault, always most willing to aid his students and correspondents in any way in his power, and beloved by all who were favored by his acquaintance.

N. L. BRITTON.

THE UNITED STATES GEOLOGICAL SURVEY.

IN his monthly report for May, 1895, the manuscript of which has been recently submitted to the Secretary of the Interior, Director Walcott, of the United States Geological Survey, remarks on the early commencement of field work this season as compared with former years, with the prospect of a longer season and more abundant results. The topographic parties nearly all took the field during May, as did also a number of geologic parties. Such topographers and geologists as were detained in Washington beyond the close of the month have since taken the field from time to time, as the exigencies of the work already in hand permitted. This early commencement of the field work of the Survey is attributable in the main to the action of Con-

gress in providing in the last Sundry Civil bill that the appropriations for the Survey for the fiscal year 1895-1896 should become available before the first of July.

In view of the importance of the Geological Survey as an instrument for the advancement of science and the development of the resources of the country, and the fact that the present report shows to a large extent the work planned for the current year, we give in some detail the different directions in which operations are in progress.

Of the geologists working in New England, Prof. N. S. Shaler was engaged principally in the preparation of his report on the Narragansett Basin, and in investigating, through the aid of Assistant Woodworth, certain morainal belts in Rhode Island. Prof. B. K. Emerson, working also in a New England area, gave two days of each week to field work for the Survey, mapping the geology of the Barre and Marlboro' sheets, of Massachusetts. In his study he was doing microscopic work and making drawings for his report. Prof. T. Nelson Dale reports that such part of the month as he was actually in the employ of the Survey was given to work on the Cambridge, N. Y., sheet.

In the State of New Jersey, Professor J. E. Wolff continued, with the assistance of Mr. Brooks, the survey of the areal geology of the Lake Hopatcong sheet. Dr. W. B. Clark, the other geologist who is working in New Jersey geology, continued the survey of the Bordentown sheet and the contiguous region. This area was taken up late in April. While in Baltimore, Dr. Clark continued his office work upon the Eocene fauna of Maryland and Virginia.

Mr N. H. Darton spent the greater part of the month in the continued preparation of the report on artesian well prospects of the Atlantic Coastal Plain. Ten days were spent on Long Island, N. Y., for the purpose of obtaining data regarding wells

and to study the geologic conditions affecting underground waters on the Island, and several trips were made to Baltimore with a similar object in view.

In southwestern West Virginia field work was prosecuted nearly all the month by Mr. Mendenhall, Mr. M. R. Campbell's assistant. Mr. Mendenhall was revising the Tazewell sheet. Having completed his office work, Mr. Campbell himself took the field about the 10th, at Alderson, in the same State. From Alderson he and his party worked down New River, studying the conglomerate series as far as Kanawha Falls. From that point they moved to the eastern edge of the Kanawha sheet. Mr. David White was of the Campbell party. He was rendering assistance in the correlation of the different horizons, mainly by the testimony of the plant remains.

Mr. Arthur Keith confined himself to office work, making a preliminary draft of the boundaries of the coal formations on the Briceville and Wartburg sheets of Tennessee, and preparing for field work, which he has since taken up. Mr. C. Willard Hayes took the field the latter part of the month in Alabama and Georgia. Mr. R. T. Hill is engaged in the completion of the Austin sheet of Texas.

Mr. G. K. Gilbert, geologist, spent the first half of the month in the continued prosecution of his work at Niagara Falls, mentioned in the last report. The object of this work was to obtain further knowledge of the details of the history of the Niagara River and the data for the illustration of a report thereon. Completing his task on the 15th, he returned to Washington and was subsequently engaged in the study of the literature of the geology of Niagara Falls and that relating to the associated problems of ice-dammed lakes.

Prof. T. C. Chamberlin, geologist, reports from the University of Chicago that Mr. Leverett continued the preparation of a re-

port upon the glacial geology of the Illinois lobe, making short excursions into the field in connection with that work. Prof. R. D. Salisbury did some work in Pennsylvania and New York, in continuation of surveys made in past years in New Jersey.

The work in the Lake Superior region, under Prof. C. R. Van Hise, was in all respects a continuation of that of the previous month, Dr. Bayley continuing the preparation of the Marquette monograph; Mr. Clements the preparation of the Michigamme monograph, and Mr. Morrow the cartographic work. The head of the party gave his time exclusively to the preparation of the paper for the Sixteenth Annual Report of the Survey.

Office work relating to the geology of the mining districts of Colorado was continued by Mr. Whitman Cross and Mr. G. H. Eldridge, and also, during the last ten days of the month, by Mr. S. F. Emmons. Mr. Emmons and Mr. Spurr were occupied in revising the manuscript of a report on the Murcur mining district.

Mr. Cross was engaged in preparing the report on the geology of the Cripple Creek district, a task which he has, since the close of the month, brought to completion. This paper will appear in the Sixteenth Annual Report. Mr. Eldridge continued the final revision of the Denver report. Messrs. Cross and Eldridge are about to take the field.

During May the maps and descriptive text constituting the Yellowstone Park folio were brought to completion, a number of additions having first been made to the sheets which, Mr. Hague thinks, will greatly enhance their value and interest. The folio is now ready for publication. Mr. Hague is now at work on the monograph on the geology of the Yellowstone Park. Mr. W. H. Weed, geologist, continued office work on the preparation for publication of the Little Belt sheet. On the 25th, un-

der the Director's orders, he made a trip to Boston, to consult with Dr. J. E. Wolf concerning official work. He returned on the 29th and resumed the work above mentioned.

The report on the gold resources of the Southern Appalachians, upon which Dr. G. F. Becker had been engaged all winter and spring, was completed about the 10th of May and placed in the Director's hands for publication. By the 14th Dr. Becker had received and corrected the printed proof of this work, and on the 16th he started, in company with Dr. W. H. Dall and Mr. Purington, for Alaska, to make the investigation touching gold and coal resources, which Congress specially authorized and provided for at its last session. As contemplated in the plans for this work, Dr. Becker will himself make the gold investigations and Dr. Dall those relating to coal. Advices from Dr. Becker, dated June 1st, show that the party had reached Sitka and had actually begun work.

As regards the office work relating to the mining districts of California, it may be stated that Mr. W. Lindgren was occupied with the microscopic study of the specimens collected at Nevada City and Grass Valley, as well as with the preparation of the descriptive text to accompany the sheets representing those districts.

Mr. H. W. Turner left Washington in May. His first work of the season will be the completion of the Bidwell Bar sheet surveyed in part last season in central California. Mr. J. S. Diller spent the last half of the month in the study of geologic material in preparation for his field work this season in Oregon, and in attending to matters connected with the Educational Series of rocks. Under his direction 285 thin or microscopic sections of rocks were made, about 300 specimens were either cut or polished, or both, and 2,150 specimens of the Educational Series were labeled. The work of Mr. T.

W. Stanton consisted principally in the revision of a paper on the fauna of the Knoxville beds. This paper was submitted for publication as a bulletin on May 30th, on which date Mr. Stanton left Washington, under orders, for field work in Texas, in accordance with the plans for the ensuing fiscal year. As stated on a previous page, Dr. W. H. Dall was assigned to special work in Alaska.

Prof. L. F. Ward was preparing his paper on some analogies in the Lower Cretaceous of Europe and America, and upon this he was engaged nearly the entire month. He stated under date of June 6 that the task was nearing completion. He gave much attention during the month to work relating to cycadean remains, visiting Baltimore and making photographs of some important specimens for illustrative purposes. Dr. F. H. Knowlton reports that with the exception of three days, which he gave to the study of a small collection of fossil wood from the Isle of Wight and the Island of Portland, England, in connection with Prof. Ward's investigations, his whole time in May was given to the study of the fossil plants of the Yellowstone Park as reported in previous months.

Prof. O. C. Marsh and his assistants continued the work on North American Dinosaurs, attention being directed during the month especially to the illustrations and text for the paper on the subject, designed for the Sixteenth Annual Report.

The field work of the *Division of Hydrography*, under Mr. F. H. Newell, was advanced in a fairly satisfactory manner. The field of operation of this Division is so vast, and the work that is being done in the different sections of the country and on the different streams is so varied in character and affected so much by local conditions, that it is quite difficult to state in general terms and few words the condition of that work at any given date.

Mr. A. P. Davis traveled during the month about three thousand miles. He established river stations at several points in Kansas and New Mexico and, later, went to Colorado, where he made measurements and rated meters. From California, Montana, Idaho, Nevada, Nebraska and other States and Territories come favorable reports of the progress of the work in its several branches. Reports from Washington and Wyoming are not so favorable.

In the east Mr. C. C. Babb spent nearly the whole month on the Potomac, making measurements by which the discharge of the stream can be computed for various heights of water at the different gauging stations.

In the office, the preparation of a bulletin, to be numbered 131, giving the reports of field for the years 1893-'94, was completed. In this bulletin are inserted all the available data concerning the various river stations of the country and miscellaneous information bearing upon the hydrographic work.

In the *Division of Chemistry*, under Professor F. W. Clarke, the number of routine analyses completed and reported during the month of May is 20, Dr. Hildebrand making 6, Dr. Stokes making 5, and Mr. Steiger making 10. In addition to this, some special investigations were under way, and these were well advanced. By Dr. Hildebrand two papers were prepared for journal publication, one on chlorite, from Cripple Creek, Colo., and the other on the estimation of titanium.

The work of the *Division of Mining Statistics*, under Dr. D. T. Day, consisted in preparations for the publication of the report on mineral resources of the United States for 1894. During the month the statistics of production of coal, lead and building stones, were given to the public, through the press, and those on iron ores, tin and the gold resources of the South were in the printer's hands.

In the *Division of Topography* nearly all the parties have been placed in the field and are at work in sections, as follows: Atlantic section, Central section, Pacific section, Indian Territory section. The Indian Territory work is a combined topographic and land subdivisional survey, and was specially authorized by Congress at its last session. Work is in progress in 23 States and Territories.

In the *General Editorial Division*, the following manuscripts were read:—Reconnaissance of Gold Fields of Southern Appalachians: G. F. Becker; for Part II., 16th Ann. Rpt. Production of Iron-ores: J. Birkinbine, Bull. 131. Water Supply Data: F. H. Newell. Text, Knoxville folio: Text, Stevenson folio. Proofs were received from the Public Printer of parts of the 15th and 16th Annual Reports and several Bulletins.

In the *Editorial Division of Geologic Maps* Mr. Willis edited the map of New York State and worked on the Marysville and Smartsville, Cal., and Stevenson, Ala., sheets. Text for the Knoxville, Tenn., Fredericksburg, Va.-Md., and Lassen Peak, Cal., sheets was read in original, and after reference to the authors sent to the press. In the *Editorial Division of Topographic Maps*, under Mr. Marcus Baker, attention was directed largely to the revision and correction of engraved atlas sheets which are about to be printed as the bases for geologic folios.

In the *Engraving Division* the 31 topographic atlas sheets were in course of engraving. Of geologic folios in course of engraving there were 10, and besides, work was continued on the 6-sheet map of New York.

In the printing department 5 geologic folios were in press, viz.: Lassen Peak and Marysville, Cal.; Staunton, Va.; Stevenson, Ala., and Knoxville, Tenn. The Staunton folio was completed. Editions of 11 topographic sheets were delivered from the press.

In the *Division of Illustrations*, under Mr. DeL. W. Gill, 105 original drawings were made during the month, comprising geologic landscapes, maps and sections and miscellaneous subjects. Engraved proofs to the number of 117 were received and examined. In the photograph laboratory 203 negatives and 1165 prints were made.

THE BIOLOGICAL EXPERIMENT STATION OF
THE UNIVERSITY OF ILLINOIS.

THE State Legislature of Illinois has made a sufficient appropriation to the Biological Experiment Station of the University of that State to provide for it an independent equipment and a separate working force.

This Station was established April 7, 1894, in leased quarters on the Illinois River, at the town of Havana, one hundred miles west of the University. It is devoted to a continuous study of the plant and animal life of the Illinois River and adjacent waters, with principal reference to ecological problems. Its main object is scientific, and the principal business of its staff is original research. Economic ends will be kept in view, and educational applications of the results of its work will be carefully regarded in the preparation of its reports.

The Station is jointly maintained by the University of Illinois and the Illinois State Laboratory of Natural History, each contributing equally to its support. It is under the general management of Professor S. A. Forbes, director of the State Laboratory and professor of zoölogy in the University. Its newly appointed superintendent is Dr. Charles A. Kofoid, its zoölogical assistant is Mr. Adolph Hempel, and its botanical assistant is Mr. B. M. Duggar.

It will be provided with a floating laboratory, 48 x 15 feet, furnished with tables, microscopes and aquatic and other apparatus of observation and experiment sufficient for twenty workman; with rooms on shore for

microscope technology and similar work; and with a naphtha launch and several skiffs as means of transportation. Its quarters will be occupied continuously throughout the year by its resident force, and will be open to advanced students of aquatic biology during the vacation season of 1896, on terms to be hereafter stated.

Papers are now finished or far advanced setting forth the results of last year's work on rotifers and Protozoa, on oligochaete worms, on Daphniidae, on insects aquatic in any stage, and on the chemical characters of the waters of the various field stations, as shown by periodical analyses. These papers will be printed separately in the Bulletin of the State Laboratory, and will also be published conjointly, at intervals, together with general discussions and other comprehensive matter, in the biennial reports of the Station.

ALEUT BAIKARKAS IN KAMCHATKA.

THERE is a statement in Dr. Guillemard's interesting account of the 'Cruise of the *Marchesa*' (vol. i., pp. 224-227) which, if left uncontradicted, might lead to erroneous conclusions in the discussion now going on as to the relationship and origin of the North American natives.

The '*Marchesa*,' in September, 1882, visited a point on the western coast of Kamchatka not far from Cape Lopatka, and there* fell in with a party of 'natives' who came out to the steamer in canoes 'built somewhat on the model of a Greenlander's *Kayack*.' One of these canoes was purchased, and on p. 228 is a figure of the '*Bow of Kurile Canoe*,' presumably the one

*The island protecting the bay 'which is not marked in the chart was named by us after Lieut. R. H. Powell.' *Gullem. Cr. Nr.*, i., p. 225 (1886). It is, however, in the Russian Admiralty charts (for instance No. 1475, corrected to 1880) and is called Tebtasut Isl. The native huts are situated back of Zheltij Mys, which is situated east of the Kurilskoje Lake and the Iijina Volcano (Itterna, Guillemard?).

bought. The Marchesa party also obtained a sea-otter bow and arrow, a figure of the latter being given on p. 225.

On p. 229 Dr. Guillemard says as follows: "We could make out nothing about the nationality of the people of this village. We had been told that some Aleuts from the Bering group had settled in this neighborhood, but it seems that the Kurile islanders have also passed northward, and established themselves on the coast near Cape Lopatka. To us it appeared that they did not differ appreciably from the Kamchatdale type, but the opinion of a mere passer-by on these matters is usually valueless."

Notwithstanding the caution with which Dr. Guillemard has expressed himself, the impression which his account leaves is that the people he met were Kuriles and that the skin-canoe is a Kurile apparatus.

The fact is that these natives were Aleuts pure and simple, former inhabitants of the Aleutian Islands (not even by way of Bering Island, I believe). The history of their location near Cape Lopatka, in Kamchatka, and the consequent appearance of the baidarka, or skin-canoe, on that peninsula is as follows:

The Russian authorities, in order to prosecute the sea-otter hunt in the Kurile Islands at the time when these still belonged to the Russian crown, transferred a number of noted Aleutian sea-otter hunters, with their families, to the Kuriles. At the time of the cession of these islands to Japan it was stipulated that such of the inhabitants as preferred to return to their homes should be allowed to do so. The Aleutian Islands having in the meantime been ceded to the United States, and the Aleuts living in the Kuriles having declared their desire of remaining Russian subjects, they were transferred to Kamchatka at the expense of the Russian government and provisionally located a few miles from Petropaulovski, on

the road between this port and Aratcha. Here they lived for several years in extreme poverty and squalor, and, as there was no way of employing them, the government had to feed them to prevent them from starving to death. The ease with which they could obtain *rooka* at Petropaulovski tended to further degrade them and render their total extinction a question of time only, if allowed to continue living in that neighborhood. It having been decided by the authorities to change their habitation, the present site of their village near Cape Lopatka was selected, as it offered a fair prospect of making them self-supporting by hunting and fishing.

These were the natives which Dr. Guillemard and his party met, and thus it came to pass that skin canoes were in use in the Kuriles and in southern Kamchatka.

The illustration of the three-hole baidarka given by Dr. Guillemard on page 226, and the description of a sea-otter bow and arrow, the latter with figure, on page 225, serve as additional proof of the correctness of the above. They are in every detail identical with specimens in the National Museum from Alaska.

LEONHARD STEJNEGER.

U. S. NATIONAL MUSEUM.

THE HISTORY OF NAVIGATION IN SPAIN.

ALTHOUGH Navarrete's *Historia de la Nautica*, published at Madrid in 1846, is now almost half a century old, very little use has been made of it in recent biographies of Columbus. In order to thoroughly understand the greatness of the discovery made by the Genoese navigator, it is essential to be acquainted with the progress of naval science up to his time, and that is what is described in the Spanish scholar's book. He begins by giving a short sketch of seamanship among the Ancients. As a great deal has been done to elucidate the subject

in our time,* a brief summary of the chief results will be sufficient for our purpose.

The Ancients had no means to determine the latitude and still less the longitude at sea, so they navigated wholly by dead reckoning. The instruments at their command were the sounding lead, and at a later time the plane chart. The absence of an instrument to measure the speed of a vessel was not very material—a good estimate of the velocity can be easily obtained without it—but the want of an instrument like our compass, to guide the pilot when thick weather prevailed, was sadly felt. Consequently winter was not considered as a season proper for navigation, and even in summer they generally ranged the coast, seldom venturing into the open sea.

Nevertheless records have been left to us of voyages accomplished by the Ancients, whose daring and perseverance has hardly ever been surpassed. The Phœnicians circumnavigated Africa from east to west some six hundred years before the beginning of our era. The Carthaginian Hannon explored the western coast of Africa. Towards the north, Pytheas of Marseille went as far as Thule, say Shetland Islands. Towards the east the Greek mariner Alexander reached China, and the pilot Hippalos taught his countrymen how to avail themselves of the monsoon for a voyage to India.

The world fell now under the sway of the Romans, one of the most unscientific peoples that ever existed, who left us a sad record of how a nation could reach a high degree of material prosperity, be great in war and in internal administration and remain as unmindful of science as the savage of the Australian wilds. As a redeeming quality may be mentioned the frankness with which the Romans acknowledged the fact. Cicero

tells us, for instance, that the Greek geometry had been degraded by them to a simple mensuration. They never became skillful seamen, but land-lubbers as they were, they somehow managed to beat at sea fleets manned by expert sailors, and then very willingly acknowledged the superior seamanship of the adversary. The demand for exotic products, which was very great during the Roman Empire, stimulated to a certain degree navigation considered from a commercial standpoint.

In Spain—about which we are here particularly concerned—the interest in seamatters, planted there by the Phœnician founders of Cádiz about 1160 B. C., was however kept up. Cartagena and Barcelona were important seaports even in that remote time.

And now a part of the world, including Spain, changed its master again. The followers of Mohammed conquered Egypt, Syria, northern Africa, Persia and the Iberian peninsula. It seemed at first that these rude warriors were going to trample all learning under their feet. But the change came very soon and the wild raiders became a cultured nation. Poetry had already the Bedawin; science was borrowed from more cultured people, the Greeks and the Indians. Not only did the Arabs master the Greek geometry and astronomy and the Indian arithmetic and algebra, but they enriched them with new discoveries. Still greater was their progress in physics and chemistry. It will be sufficient for our purpose to state that they improved the astronomical tables and the astrolabe and borrowed the compass from the Chinese. A certain Bailak from Kisgak tells us:*

“The mariners who navigate the Indian sea are said to use a little hollow iron fish

*See the recent works by Breusing (*Nautik der Alten*, Bremen 1886, translated into French by M. Vars, Paris 1887) and Torr (*Ancient Ships*, Cambridge, 1894).

*I borrow the information from Professor Wiedemann's pamphlet: *Ueber die Naturwissenschaften bei den Arabern*, Hamburg, 1890.

which they manage to arrange so that if you put it into a dish of water it floats and points with its head and tail toward the two directions north and south."

So the dead reckoning was put on a firmer basis and the determination of the latitude at sea became possible. It would be very interesting to find the first reference to the compass, known to the Arabs as far back as 854, in the European literature. Navarrete found the following passage in the Spanish Laws compiled in the middle of the thirteenth century:

"And just as the mariners guide themselves in a dark night by means of the needle which is a mediator between the star and the stone and shews them where they go, so," etc., etc.

A well-known passage in Dante (*Par.* XII., 29) proves that in his time the compass was a familiar object. While the sciences flourished among the Moslems they were sadly neglected in Christian Europe.

Towards the twelfth century, however, a better day dawns in Spain. We see the Kings of Castilla and Leon very solicitous to spread knowledge in their kingdoms. Alfonso VIII., of Castilla, establishes a seat of learning in Palencia. Alfonso IX., of Leon, founds the University of Salamanca, and finally Alfonso the Wise publishes his celebrated tables. In his time flourished the renowned Mallorcan Raimundo de Lulio, who among many other subjects devoted particular attention to seamanship. He gave a geometrical construction to find the ship's place if her preceding place, the course steered and the distance run are known, and improved the astrolabe. As helps to navigation used in his time he mentions the chart, compasses, the needle and the sea star. Soon afterwards the Italians and the Catalans improved the plane chart, Regiomontanus invented a metal astrolabe, and Prince Henrique appeared on the scene as a great promoter of maritime discovery.

I shall not stop to give here an account of the careers of the great discoverers of the time, Columbus, Vasco da Gama, Magalhães, but close my review by presenting a short sketch of the great activity in Spain in maritime affairs.

The Spanish Renaissance never found a worthy historian, so that I shall simply state that at the beginning of the sixteenth century we find the Spanish mathematicians Ciruelo and Siliceo teaching at the University of Paris, the philosopher Vives at Oxford, while Servet, Harvey's forerunner in the discovery of the circulation of the blood, was burned alive in 1553.

At the same time the Spanish government was very active in promoting seamanship. The office of pilot major and a chair of cosmography and navigation were created, and an official maker of nautical instruments was appointed. The pilots had to pass an examination before a tribunal consisting of the pilot major, the professor of navigation and the maker of instruments, assisted by at least six expert pilots. Inventions tending to facilitate navigation were rewarded.

Thus Diego Ribeiro was awarded in 1532 a pension of 60,000 maravedís* a year for his invention of metal pumps. Before granting this pension, his invention had been submitted to a severe test on an experiment vessel having a commission on board to judge of the advantage gained by using the new pump. A few years later, in 1545, Vicente Barrero, who was the first in Spain to make wooden pumps, obtained an exclusive privilege to construct them for ten years, his pumps having been found much cheaper than those of Ribeiro.

In 1519 Martin Fernandez Enciso published the first Spanish treatise on seamanship, talking as his guide not only the classical writers Ptolemy, Eratosthenes,

*A maravedí was worth about two-thirds of a cent in gold.

Pliny and Strabo, but also the experience which, as he says himself, is the mother of all things.

The next Spanish works on navigation to be mentioned are those of Fernandez* (1520), Faleiro (1535), Medina † (1545), and Cortés ‡ (1551), through the numerous translations of which the science of the Spanish pioneers spread all over the civilized world.

JOSEPH DE PEROTT.

CLARK UNIVERSITY.

CURRENT NOTES ON ANTHROPOLOGY (XI).

RACIAL AND ETHNIC TRAITS.

TIME was when Nott and Gliddon and their colleagues and disciples undertook to prove the fundamental diversity of the races of mankind, physically and mentally. The pendulum has now swung to the other extreme, and various leading ethnologists deny the existence of any such things as racial or ethnic traits, tendencies or capacities. For instance, Dr. Otto Stoll, in his thoughtful work, 'Suggestion and Hypnotismus' (cap. xx.), calls racial psychology a 'deceptive appearance' (Trugbild); Dr. S. R. Steinmetz, in the introduction to his 'Entwicklung der Strafe,' quotes with approval the opinions of those who say that the only psychical differences in races are those arising from their surroundings, etc.

If such expressions—not always clearly enunciated—mean merely that the traits of races and nations are the slow results of their *milieu*, and are as permanent as the physical results, color, hair, etc., they are truisms which nobody denies; but if, as is apparently the case, they intend to say that at present the Fuegian or the Bantu has the intellectual endowment of the European, and all that he requires to make use

* Translated into French.

† The French translation had five editions, the German six, the English one, the Italian two, and the Flemish one.

‡ Translated into English.

of it to as good effect is to be given an equal chance, this is contradicted by uniform and repeated experience. The mental traits of races and peoples are as much their peculiar characteristics as are their bodily idiosyncrasies, and are just as impossible to change by any quick process. The theories of education and government which have been based on the opposite view have steadily failed. The changes in the mental are strictly correlated to those in the physical system. It is vain for ethnologists to seek to forget this elementary physiological fact.

THE PROGRESSIVE DEPOPULATION OF
NORTHERN REGIONS.

THE last census of Russia showed that its northern province, Archangelsk, had lost over ten thousand of its already sparse population within a decade, not from any general or violent cause, but from the independent migration of families to more genial climes toward the south. Mr. H. C. Bryant and other Arctic travelers assure me that there is no doubt about the advancing extinction of the natives of the extreme north of America and Greenland. Dr. A. Jacoby, in the 'Archiv für Anthropologie' for November last, draws a painful picture of the degeneration and disappearance of the Samoyeds and other boreal tribes of Siberia. Nearly everywhere the arctic and sub-arctic zones have fewer inhabitants than a half century ago.

The general causes are obvious. One is the destruction of the native tribes by the introduction of new modes of life, new diseases, alcohol and idleness; another is the removal of all who can go, to climates of less severity. The arctic regions, like mountains, were not originally chosen by preference as homes, but were the refuges of conquered and dispersed bands. Now that the pressure is removed such inhospitable climes will certainly be occupied less and

less. The center of gravity of the population of the earth tends more and more to fix itself between the isothermals of 40° and 60°; we might even say 45° and 55°. Neither tropic nor sub-arctic countries offer the prizes which the masses of the human race now long for.

THE PICTOGRAPHS OF LOWER CALIFORNIA.

AN important article on this subject by M. Leon Diguët in 'L' Anthropologie,' 1895, No. 2, should attract the attention of American archaeologists. It gives a list of some thirty engraved or painted designs on rocks in Lower California between lat. 23° and 29°, and presents copies of a number of them, with a satisfying discussion of their character and origin.

The paintings are in red, yellow, black and white, and represent ideograms, persons or animals, these latter at times associated so as to form a group or scene; most of them are on boulders in the vicinity of springs or streams, or else in caves. The petroglyphs are often deeply and clearly cut on the surface of hard rocks, and are of the same general character as the paintings, hence doubtless by the same people.

The first missionaries to the natives of the region observed and noted these curious designs, and inquired of the existing tribes their origin. The reply was that they were the work of a race of giants, who in ancient times came down the coast from the north. This, of course, merely meant that they knew nothing of the designers. The idea of giants arose simply enough from the uncommon stature of some of the persons represented, about seven feet high. It is well known that the tribes who occupied Lower California when it was first explored were extremely rude and devoid of arts.

THE EARLIEST HUMAN OCCUPANTS OF THE ATLANTIC WATERSHED.

A FEW years ago 'advanced' archaeologists entertained no doubt about the vast

antiquity of the human occupation of the Atlantic watershed. There were 'paleolithic sites' on the Potomac, tools from the Trenton gravels, 'glacial hearths' in New York State, etc.

Matters have changed. The ominous word *talus* robs the Trenton gravels of their fame; 'quarry rejects' explain the paleolithic sites; and so on with one supposed proof and another. Then Mr. H. C. Mercer turns 'the dry light of science' on the darkness of the caves of the Alleghanies, and finds nothing in them older than our familiar friend, the red Indian. Finally, Mr. Gerard Fowke, in a pamphlet just published by the Bureau of Ethnology, gives the results of his archaeological investigations in the valleys of the James and Potomac Rivers, announcing the somewhat startling conclusion that not only did he find no sign whatever of any other occupancy than that of the red Indian, but even this he is convinced could not have been of very long duration, or what could really be called ancient.

Another publication by the Bureau, by Mr. James Mooney, entitled 'The Siouan Tribes of the East,' shows by a large collation of authorities that the Dakota stock at the time of the discovery occupied most of the land east of the mountains, between the Santee River and the Potomac. Mr. Horatio Hale was the first to call definite attention to this unexpected fact.

It is difficult to believe that the splendid forests of the Atlantic slope and its fertile river bottoms remained untrampled by man until our familiar Sioux and Five Nations and Delawares took possession of them, a few centuries before Columbus. Such a supposition involves puzzling anthropologic corollaries; but for the present we must accept it as the actual result of investigation.

D. G. BRINTON.

NOTES ON AGRICULTURE (V.)

NATIVE PLUMS AND RUSSIAN CHERRIES.

MR. HEDRICH, in Bulletin No. 123 of the Michigan Experiment Station, states that our native plums are coming into prominence. They are three weeks earlier than the European sorts, and of the 150 varieties the De Soto, Wild Goose and Miner are the most promising. They are not particular as to soil and desirable 'because of their immunity from diseases and insects.'

The introduction of cherries from Russia dates from 1882. They are recommended for localities too cold for ordinary cherries. The fruit is reddish black in color, late in maturing and with 'a peculiar astringent flavor which is often very pleasant.'

PINEAPPLE CULTURE.

BULLETIN No. 27 from the Florida Experiment Station gives, first of all, a full-page plate of a pineapple field in full fruit. Dr. Washburn, the experimenter, has raised the peculiar fruit crop for nine years, and is convinced that it is profitable and that 'pines' can be grown over a large portion of Florida. The plants need to be set eighteen inches apart each way and abundantly supplied with rich food.

THE FLOW OF MAPLE SAP.

It is natural to expect that nearly every subject connected with the production of food supplies will be considered by the Experiment Stations. The one by Mr. Woods of the N. H. Station is upon the flow of sap in maple trees. It is found that the flow of sap is dependent largely upon the depth of the hole, or 'tap,' and the idea that nearly all the sap comes from the outer wood is erroneous, and that sugar makers may profitably tap their trees to a depth of four inches. It was also shown that there is very little gain by tapping a tree in two places; one deep and small hole upon the south side of the tree is sufficient.

DAMPING OFF.

PROFESSOR ATKINSON, in Bulletin No. 94 of the Cornell Station, reports at length upon a study of microscopic fungi that work upon seedling plants in greenhouses and destroy them by what is commonly known as 'damping off.' This fatal result is occasioned by great moisture content of the soil, high temperatures, close rooms and insufficient light—all of which favor the growth of the low forms of fungi, causing the destruction of the stems of the seedling. The conditions above given should be as far as possible eliminated. As the moulds, etc., enter the plants from the soil it is evident that the latter should be as free as may be of the germs. Diseased plants need to be thrown away and, in serious cases, the soil likewise. The soil may be sterilized by steam heating before the seeds are sown. Those who would have healthy greenhouse plants must be wise as mycologists and as loving as mothers.

BYRON D. HALSTED.

SCIENTIFIC NOTES AND NEWS.

THE CONGRESS OF PHYSIOLOGISTS.

As we have already stated, the third *International Congress of Physiologists* will be held at Bern, September 9th to 13th, 1895. Prof. Kronecker, director of the physiological laboratory of the University, has kindly expressed his readiness to afford to members of the Congress all facilities for demonstration and experiment, as well as for the exhibition of scientific apparatus. It is especially wished to have a full exhibition of apparatus, which may be contributed either by physiologists or by instrument makers recommended by members of the Congress. Titles of communications from America may be sent to Professor Frederic S. Lee, Secretary, American Physiological Society, Columbia College, New York City. Professor Bowditch has signified his intention to be pres-

ent, and it is hoped that there will be a full attendance of American physiologists, more especially as at the preceding meeting at Liège there was only one representative of the United States. The following are the resolutions adopted at the first International Congress in 1889:

1. An International Congress of Physiologists shall be held triennially, with the object of contributing to the advancement of Physiology by affording physiologists of various nationalities an opportunity of personally bringing forward experiments, and of exchanging and discussing their views together, and of becoming personally acquainted one with another.

2. Membership of the Congress shall be open to all professors and teachers of biological science, belonging to a Medical Faculty or any other similar scientific body, as well as to all scientific men engaged in biological research.

3. The sessions of the Congress shall be devoted to physiological communications and demonstrations. Further communications relating to original research in Anatomy, General Pathology and Pharmacology are acceptable in so far as they present features of general biological interest.

4. It is desirable to-keep the communications as far as possible demonstrational and experimental in character.

5. No official report of the work of the Congress shall be published.

The following regulations were discussed and adopted for conducting business at the sessions of the Congress:

1. The languages recognized as official at the Congress are English, French and German.

2. At each sitting two Presidents for the next sitting are chosen by the meeting, on the proposal of the Chairman.

3. At the opening of the Congress the meeting elects for each of the official languages a General Secretary, who shall su-

perintend the preparation of the minutes of the meetings.

4. The minutes are written in the three official languages by three Secretaries chosen at each sitting by the President in the chair. Each person who makes a communication shall sign the protocol of his own communication. The President in the chair shall confirm the correctness of the minutes for the whole sitting.

5. The length of a communication may not exceed fifteen minutes. When that period has been exceeded the President must ask the meeting whether it desires the communication to continue further.

6. A motion backed by three members for the closure of a communication or of a discussion must be immediately put to the vote.

7. The press shall not be officially admitted to the Congress; each member is free to send private communications to scientific journals.

THE YERKES OBSERVATORY.

A PROGRAMM recently issued from the University of Chicago gives the following details concerning the site and building of the Yerkes Observatory:

"The Observatory has been located about a mile from the town of William's Bay, at Lake Geneva, Wisconsin, in an ideal rural region, free from the dust and smoke of civilization and removed from the tremors of railroad traffic. Lake Geneva is about 70 miles from Chicago, and is reached by a branch of the Northwestern Railroad. The site of the Observatory includes 50 acres of timbered land, fronting on the Lake, in the midst of one of the most beautiful regions in the country. The buildings will stand on a gently sloping hill, which rises some 200 feet above the water, and as Lake Geneva is 400 feet above Lake Michigan, the Observatory will be approximately 1200 feet above sea level. It is confidently believed that the favorable conditions of the site, and the established steadiness of the atmosphere in this region, will insure the very best seeing."

"The Observatory building will be of the form of a Roman T, with the great dome at the foot of the letter, the small domes for the 16-inch and 12-inch

telescopes being at the other extremities. The main axis of the Observatory, which is some 300 feet in length, will run east and west; in this will be situated the library and the lecture rooms, laboratories for physical, chemical and photographic work, computing rooms, offices of the astronomers, etc. The building will be made of the most durable material and will be substantially fire-proof. The internal furnishing will include the best modern facilities for heating and lighting, so that the Yerkes Observatory, with its powerful and delicate instruments, will constitute an admirable material equipment for astronomical research."

The mounting of the great telescope by Warner and Swasey, it will be remembered, was exhibited at the Chicago Exposition. All the motions of the instrument are effected by electric motors. Mr. Alvan G. Clark has recently stated that work on the object glass is progressing satisfactorily. The objective is 40 inches in diameter, with a focal length of nearly 64 feet. The largest objective hitherto made by Mr. Clark was that for the Lick Observatory, 36 inches in diameter. Mr. Clark believes that the power of the telescope increases in proportion to the size of the lens and that the limit has not yet been reached.

THE ROYAL ASTRONOMICAL SOCIETY.

ACCORDING to the *London Times* the last meeting of the present session was held on June 4th, Dr. A. A. Common, president, in the chair. For the first time in the history of the Society, a paper was read before it by a lady, Miss Alice Everett, dealing with the orbit of the double star Iota Leonis. Four photographs presented by American astronomers were shown. The first of these was a representation of 'the old moon in the new moon's arms,' *i. e.*, of the earthlit portion of the new moon. An exposure of 30 sec. showed very distinctly the chief formations of the part in earth-shine. The second and third photographs were, like the first, by Professor E. E. Barnard, and revealed a most extensive nebula embracing the main portions of the constellation Scor-

pio. The fourth photograph, by Professor Keeler, showed a portion of the spectrum of Saturn and its rings, and by the different displacements of the lines in different parts of the rings proved that the inner particles of the rings were moving faster than the outer particles—in other words, that the rings are composed of swarms of minute satellites moving in separate orbits, and are not solid, continuous bodies. Professor C. Michie Smith, director of the Madras Observatory, described the work which he had to undertake since the death of the late director, Mr. Pogson—*viz.*, the preparation and publication of some 30 years' arrears of observations. This had now been finished, and only the catalogue waited completion. He also described the new observatory which the Indian Government was building at Kodai Kanal, on the Pulney Hills, at a height of 7,700 feet above sea level. Amongst other papers read during the evening was one by Mr. Lewis on measures made of the diameter of Jupiter and its satellites at the Greenwich Observatory, measures which by their accuracy afforded a gratifying evidence of the efficiency of the great telescope of 28 inches' aperture recently installed there.

GENERAL.

M. BERTHELOT announced, at the meeting of the Academy of Science of Paris on June 17th, that he had caused argon to enter into combination with the elements of carbon disulphide.

PROFESSOR COPE will publish shortly a work in which he will adduce the evidence in favor of the Neo-Lamarekian view that variations of character are the effect of physical causes and that such variations are inherited. He will aim especially to coördinate the facts of evolution with those of systematic biology.

MR. ARTHUR WINSLOW requests us to state that he has for distribution and will

send on application a list of errata intended to accompany his report on the Lead and Zinc Deposits of Missouri.

In its issue of June 27th, *Nature* reprints from *Insect Life*, in a slightly condensed form, an article on 'Social Insects' by Professor C. V. Riley, delivered as President's address before the Biological Society of Washington. Professor Riley says that insects undoubtedly possess the senses of sight, touch, taste, smell and hearing, but that touch is perhaps the only sense that can be strictly compared with our own. There is also the best of evidence that insects possess other sense organs with which we have none to compare.

THE International Statistical Institute will hold its fifth meeting at Berne from the 26th to the 30th of August next.

AN addition has recently been made to the Arnold Arboretum (Harvard University) of some fifty acres of land, making the whole area now two hundred and twenty-two acres.

ACCORDING to the New York *Evening Post*, Prof. Koebele, of California, whose discovery of the Australian ladybug as a foe of the black scale in California fruit orchards has been of so great value, has found in Japan an insect which he thinks will prove equally fatal to the potato bug.

THE first week of the Summer Congress at Greenacre, on the Piscataqua, was devoted to the Conference of Evolutionists which held its first meeting on July 6th, under the direction of Dr. Lewis G. Janes, President of the Brooklyn Ethical Association. The program was as follows:

Saturday, July 6th—Evolution Conference, under the direction of Dr. Lewis G. Janes, President of the Ethical Association; 3 P. M., Professor Edward D. Cope, Ph. D., of the University of Pennsylvania, 'The Present Problems of Organic Evolution'; 8 P. M., paper from Herbert Spencer, of London, Eng., 'Social Evolution and Social Duty,' to be followed by a symposium and brief addresses.

Monday, July 8—3 P. M., Mr. Henry Wood, of Boston, Mass., 'Industrial Evolution'; 8 P. M., Mr. Benjamin F. Underwood, Editor *Philosophical Journal*, Chicago, Ill., 'How Evolution Reconciles Opposing Views of Ethics and Philosophy'; letters and brief addresses.

Tuesday, July 9—3 P. M., Professor Edward S. Morse, of the Peabody Institute, Salem, Mass., 'Natural Selection and Crime'; 8 P. M., Dr. Martin L. Holbrook, editor *Journal of Hygiene*, New York, 'Evolution's Hopeful Promise for Human Health.'

Wednesday, July 10—3 P. M., Rev. Edward P. Powell, of Clinton, N. Y., 'Evolution of Individuality'; 8 P. M., Miss Mary Proctor, of New York, 'Other Worlds Than Ours,' with stereopticon Illustrations.

Thursday, July 11—3 P. M., Rev. James T. Bixby, Ph. D., of Yonkers, N. Y., 'Evolution of the God-Idea'; 8 P. M., Dr. Lewis G. Janes, President Brooklyn Ethical Association, 'Evolution of Morals.'

The Congress will be continued during the months of July and August, a lecture being delivered on each afternoon and occasionally one also in the evening. The last lecture will be delivered on August 31st, by Hon. Carroll D. Wright.

PROFESSOR FRASER has obtained, we are informed, definite proof of the antidotal properties of the blood serum of venomous serpents. This result was not unanticipated, as will have been gathered from the statements already published, but its establishment is a matter of great interest, and, perhaps, of some practical importance, since never before, probably, have the bane and the antidote been brought so near together. —*British Medical Journal*.

Two distinct earthquake shocks were felt in Springfield, Mo., on July 8th. The first at 7:30 o'clock and the second a minute later. The duration of the first vibration was five seconds and the second two seconds. No damage was done.

ON July 10th, according to the *Evening Post*, several severe earthquake shocks were experienced in the Caspian and Ural districts of Russia. Many houses were destroyed at Usunada, Astrachan and Erasnovodsk.

At the sixty-first annual meeting of the *Royal Statistical Society* it was announced that the subject of the essays for the Howard Medal with £20 to be awarded in 1896 is 'School Hygiene in its Mental, Moral and Physical Aspects.' The essays should be sent in on or before June 30, 1896.

ACCORDING to the *Medical Record* the meeting of Bacteriologists, held in New York, June 21st, resulted in the appointment of a committee to consider both the papers presented and the discussion that followed, and to make a report to the American Health Association as to the most desirable methods to be observed to secure the greatest uniformity in the results of the bacteriological examination of water. The members of this committee are: Professor W. H. Welch, M. D., chairman; Professor W. Sedgwick, Ph. D., Professor Theobald Smith, M. D., Professor T. M. Prudden, M. D., Professor J. G. Adami, M. D., George W. Fuller, S. B., Professor A. C. Abbott, M. D., Professor V. A. Moore, B. A., M. D.

A NEW Meteorological Observatory has been established on the summit of Mount Wellington in Tasmania.

SIR EDWARD MAUNDE THOMPSON, Principal Librarian of the British Museum, has been elected a corresponding member of the philosophico-historical section of the Berlin Academy of Science.

At the annual meeting of the Numismatic Society of London, Sir John Evans presiding, the silver medal of the Society was awarded to Professor Theodor Mommsen, the veteran historian of ancient Rome, for his distinguished service to the science of Numismatics. Dr. Barclay Head, keeper of coins in the British Museum, received the medal for Professor Mommsen.—*London Times*.

THE last meeting of the Royal Meteorological Society for the present session was held on June 19th. Mr. R. H. Curtis, F.

R. Met. Soc., read a paper on the 'Hourly Variation of Sunshine at seven stations in the British Isles,' which was based upon the records for the ten years, 1881-90. January and December are the most sunless months of the year. The most prominent feature brought out at all the stations is the rapid increase in the mean hourly amount of sunshine recorded during the first few hours following sunrise and the even more rapid falling off again just before sunset. Mr. H. Harries, F. R. Met. Soc., read a paper on the 'Frequency, Size and Distribution of Hail at Sea.' The author has examined a large number of ships' logs in the meteorological office and finds that hail has been observed in all latitudes as far as ships go north and south of the equator, and that seamen meet with it over wide belts on the polar side of the 35th parallel.

THE *Medical Record*, New York, has been enlarged so that each weekly issue now contains 36 pages of reading matter.

Nature states that the Cracow Academy of Science offers prizes of 1000 and 500 florins for the best discussion of theories referring to the physical condition of the earth, and for the advancement of some important point connected with the subject. Memoirs must be sent in before the end of 1898.

UNIVERSITY AND EDUCATIONAL NEWS.

ANTHROPOLOGY IN HARVARD UNIVERSITY.

THE Department of American Archaeology and Ethnology in Harvard University, under the direction of Professor F. W. Putnam assisted by Dr. G. A. Dorsey, has just issued its announcement for 1895-96. The first course in general anthropology is intended to give students a general knowledge of the subject and to be preparatory to advanced work in physical anthropology, ethnology, sociology and history. The first

part of this course will be devoted to the study of somatology or physical anthropology; the second part to ethnology, with special reference to the origin and development of primitive arts and culture; and the third part to archaeology and ethnography, in which man will be considered in relation to his distribution over the earth from geologic to the present time, and his division into groups. Each group or variety of man will be studied separately, special attention being given to American groups. These subjects will all be studied with the aid of work in the laboratory and museum. A second course is announced, entitled *Research Course*, which will be conducted under the immediate supervision of Professor Putnam and will require three years for its completion. This course will be carried on by work in the laboratory and museum, lectures, field work and explorations, and in the third year by some special research.

This course is in the first place intended for graduate students who are candidates for the degree of Ph. D., but it is also open to students who have taken Course I., or its equivalent, and who may be competent to undertake it.

The facilities at Harvard University for the study of anthropology are particularly favorable. The collections of American archaeology in the Museum are unsurpassed. The osteological collection contains over 3000 human crania and several hundred skeletons for the comparative study of the different races. In addition to the large library of the University, the library of the Peabody Museum contains 1400 volumes and 1700 pamphlets, covering the whole field of anthropology, and includes the principal anthropological journals, proceedings and reports of societies of the United States and of Europe.

In addition to the scholarships annually awarded on the nomination of the Faculty of Arts and Sciences, there are three schol-

arships which are awarded only to students in anthropology. The Hemenway Fellowship of \$500, to be held by a student of Harvard University pursuing the study of American archaeology and ethnology, is awarded annually by the Trustees of the Peabody Museum to a student in the Graduate School. The Than Fellowship (the annual income of which is \$1050), for work and research relating to the Indian race of America, or other ethnological and archaeological investigations, is now payable, under certain conditions, by the terms of the gift, to a special student in connection with the Peabody Museum, nominated by the founder. And the Winthrop Scholarship, to be held by a student of American archaeology and ethnology, is awarded annually by the corporation. The annual value of this scholarship will probably be \$200.

UNION COLLEGE.

THE recent centennial celebration of Union College calls attention to the fact that it was the first American college that was not founded under the auspices of a special religious denomination. It is said also to have been the first college to make scientific courses and modern languages parts of its curriculum. In the course of the exercises of the centennial celebration addresses were made by representatives of the Episcopal, Dutch Reformed, Methodist, Baptist, Presbyterian and Roman Catholic Churches, and greetings were received from representatives of the faculties of Harvard, Yale, Columbia, Johns Hopkins, Brown, Amherst, Williams, Dartmouth, Bowdoin, Washington and Lee, Rutgers, Hamilton and Vassar. Among the speakers were Bishops Doane and Potter and Presidents Gilman, Hall, Scott, General Andrews and Taylor.

GOVERNOR HASTINGS has signed the bills passed by the Legislature of the State of Pennsylvania appropriating \$200,000 to the

University of Pennsylvania, \$212,000 to the Pennsylvania State College and \$112,000 to Jefferson Medical College. Large sums are also appropriated to some forty different hospitals throughout the State.

THE Rev. O. C. S. Wallace has accepted the chancellorship of McMaster University.

DR. J. L. GOODNIGHT has been appointed president of the West Virginia University, and Dr. P. R. Reynolds vice-president.

THE program of the department of astronomy in the University of Chicago announces among its officers of instruction S. W. Burnham, professor of practical astronomy, and E. E. Barnard, professor of astronomy, but the courses during 1895 will be given by Professor George E. Hale, Dr. T. J. J. Lee and Dr. Kurt Laves.

PROFESSOR ROBERT ADAMSON, now of the University of Aberdeen, has been appointed professor of logic in the University of Glasgow.

MR. W. T. A. EMTAGE, professor of mathematics and physics at University College, Nottingham, has been appointed principal of the Wandsworth Technical Institute.

THE regents of the University of California have built two brick dwellings on the summit of Mt. Hamilton for the use of the astronomers of Lick Observatory.

STEPS are being taken for the foundation of a Jewish University at Jerusalem.

CORRESPONDENCE.

AN INTERNATIONAL CONGRESS OF BIBLIOGRAPHY.

TO THE EDITOR OF SCIENCE: I have followed with great interest the discussion in SCIENCE about the proposed general index of scientific literature, the more so, as this subject has engaged my own speculations for some time past. Three or four years ago, while still in Sweden, I tried to interest librarians and literary men in the founding of a Bibliographic Society, one of the aims of

which should be to maintain a bibliographic bureau much of the same kind as foreshadowed by some of your correspondents. And last year I read before the *New York Library Club* a paper on 'International Subject Bibliographies,' afterwards printed in *The Library Journal*, July, 1894. The points there specially emphasized were:

1. That the big, monumental bibliographies are things of the past, the need of our days being shorter lists of the available literature in the several sciences and branches of sciences.

2. That such bibliographies should be international.

3. That the work should be carried on from some central bureau, established in connection with some great general library, and which could serve the double purpose, besides this one, of being an information bureau for scientific literature, and a training school for bibliographers. Of such bureaus there could be established several, *e. g.*, one for natural and physical sciences; one for history, geography and archaeology; one for anthropology, social and political sciences, etc., and of course there would be needed one set of bureaus here in America, and one or several in Europe.

4. That the work should be in charge of some international congress, as I looked at it then, a Congress of Librarians.

I wish to emphasize right here, as has been done by the Harvard University Committee, that the word *science* should be taken in its very broadest aspect, no subject that can be treated in a systematic and scientific way to be from the outset excluded.

I will not enlarge now on the question of card index *vs.* book index, or on the several other details that have come up in the discussion, as I consider these to be of secondary importance to the questions: Shall anything whatever be done in the matter? And by whom?

If the first of these two questions is answered in the affirmative, the working body created and necessary means secured, then the details of the plan can safely be left for that body.

The *Royal Society* gave as the date, when the work ought to be in shape to begin, the year 1900; and I think that year is none too far away, as the necessary preparations, as a matter of course, will take some years.

It was proposed, and specially by Mr. G. Brown Goode, in his very full and suggestive article, that an *International Congress of Science* be organized, something of the same character as the American and British *Associations for the Advancement of Science*. I agree fully with this proposal of an international congress. But I would make its scope more narrow and to the point, an *International Congress of Bibliography*. And to prepare for this, I would suggest that there be started right here an organization committee to consult with interested bodies and persons both in America and in the European countries. Will the Editor of *SCIENCE* take this matter in his hands and call such a committee?

AKSEL G. S. JOSEPHSON.

LENOX LIBRARY, NEW YORK.

A CARD CATALOGUE OF SCIENTIFIC LITERATURE.

THE valuable papers that have appeared in *SCIENCE* on the practicability of a card catalogue of scientific literature have awakened a deep interest in the subject among those who feel how desirable a work of this kind would be to each individual worker in the field of science. Already an immense amount of scientific literature has accumulated which needs to be brought together in such a manner as to be readily accessible to the investigator, and, when we consider the rate at which it is increasing, the necessity for adopting and putting into operation some plan by which the users of scientific

literature may be able to find all that has been written upon a given subject pertaining to science becomes strikingly apparent.

The writer has been engaged in preparing a bibliography and index of certain subjects for several months past, and the desire that the results and such tentative deductions as may be drawn from them may be added to our knowledge of the actual possibilities of a catalogue of scientific literature, and that other workers in this line may be induced to give us their experience, represents the object of this communication. The work just referred to was begun without previous training in this special line and with somewhat indefinite ideas as to what might be accomplished in the time that could be devoted to it. The opinions that have been formed during its progress, in their bearing on the present discussion, will first be stated before describing in some detail the scope and character of the work that is now being carried on.

1. The card catalogue, it has been said, has its limitations. This must be evident to every one when it is considered that such a catalogue as has been recommended to the Royal Society by the Harvard University Committee will extend over a series of years and must inevitably become bulky and unwieldy even when applied to but a single branch of science. Then, too, something more than a bibliography is becoming necessary. This is readily seen when one considers the time and labor expended in frequently running through a long list of titles of papers in order to find what has been written on a given subject.

2. Such a work should be published in book form after the close of each year and contain a bibliographic catalogue and a subject index. It is unnecessary that the indexing should be carried to the extreme, but simply to gather together under each special division of every branch of science

those papers which bear on that particular subject. It has been urged that none but the expert or specialist should undertake subject indexing. It is desirable that the scope and arrangement of the subject index of each branch of science should be determined by specialists in that particular branch. But, since it is not possible nor even desirable to go to the extreme in indexing, it seems quite probable that a general subject index of all the principal subdivisions of each branch of science can be accurately arranged on a previously determined plan, by one who has only a general knowledge of the principles on which each of the branches upon which he is working is based.

3. International coöperation in the past has not been of such a character as to fill one with confidence that it would successfully manage a work of such magnitude. The scope and plan of the work should be determined by an international committee, but the responsibility for the accuracy and prompt publication of the matter should be as limited as possible. An international committee might be selected to determine the scope and arrangement of the work, the language or languages in which it is to be printed, the person or persons who are to be in charge of its preparation and responsible for its accuracy and completeness, and to adopt a plan for raising the necessary funds. One person might be selected from each of the several European countries and from the United States to prepare a bibliography and index, on this predetermined plan, of all scientific literature published in their own country during each year; this manuscript to be forwarded to the central office and there examined and arranged in final form, and each person to receive compensation and credit for the individual work performed. To carry out such a plan involves a great amount of careful, painstaking and laborious work, and its success would largely

depend on the proper selection of individual workers, and on the coöperation with them of the scientific world in general.

4. It seems quite necessary that a concise synopsis of the contents of each paper should be made and form a part of the bibliography. This should be printed in the language in which the paper is written, and should be translated into English or French or both. This adds greatly to the work of preparation, but it is the only way to make it of practical use to the hundreds, possibly thousands, who would use such a work.

5. It should not only be published as a whole, but should be so prepared as to be separated into different parts to be distributed as separates for the use of those who do not care to subscribe for the whole work. By determining the arrangement of the index before beginning the perusal of the literature, on one side of the catalogue card could be written the entry for the bibliography, and on the reverse side the subdivisions of the index under which the paper properly belongs. Copies of these cards could be made, and from these a bibliography and index of any branch or a number of branches of science could be published separately with a minimum amount of labor and expense.

The work which has been heretofore referred to as being carried on by the writer comprises a bibliography and index of North American geology, paleontology, petrology and mineralogy and is to be published as a bulletin of the United States Geological Survey. It is intended as a continuation of the previous publications of the Survey of the Record of North American Geology, but the scope of the work and its arrangement have been materially changed. The first number contains a record of papers published during 1892 and 1893 and is now in press. The work for the year 1894, it is expected, will be distributed before the close of the present year, and the manuscript for

1895 will be ready for the printer shortly after its close.

It is divided into two parts: a bibliography and an index. The bibliography is arranged alphabetically by authors' names and contains the titles of each paper, place of publication, references to abstracts and reviews, and a brief summary of the contents. The entries are numbered from 1 to something over 1100 and are used for index reference. The index of the four subjects is published as a whole and is arranged alphabetically. Its geographic arrangement is by States and Territories of the United States and the other political divisions of North America. The geologic subdivisions are those of the different geologic periods and dynamic, economic, glacial and physiographic geology. The papers relating to economic geology are arranged by condensed titles of papers under the different geographic subdivisions which they describe, and there is also given a list of the useful minerals and ores described. Under mineralogy is given the condensed titles of papers and a list of minerals described. Petrology is divided geographically by the States and countries in which the rocks described occur and by a list of rocks described. Paleontology is subdivided by the different geologic periods and a list of genera and species described. In each of the lists of ores, minerals, rocks and genera and species the paper in which they are described is referred to by author's name and number of the entry in the bibliography. These represent the main features of the index.

In making up the bibliography the library catalogue card is used (size $4\frac{1}{2} \times 6\frac{1}{2}$ inches). On one side is written the entry that appears in the bibliography, and on the other the subdivisions of the index under which the paper is to be listed. In this manner all the information in regard to each paper is assembled on one card. Thus

the indexing can be determined on while the paper is still in hand, and, as soon as the bibliography is complete, the task of making up the index can be easily and rapidly accomplished.

The following specimen card illustrates the plan:

— FACE OF CARD.

HILL (Robert T.), Geology of parts of Texas, Indian Territory and Arkansas adjacent to the Red River. Geol. Soc. Am., Bull., vol. 5, pp. 297-338, pls. 12-13, figs. 1-4.

Describes the physiography of the region. Gives a list of the Cretaceous, Tertiary and Pleistocene formations and their subdivisions, whose outcrops at different localities are described. Gives lists of fossils found at certain horizons, discusses the oscillations of land and sea, and includes the author's conclusions as to the Cretaceous section of the region. Plate 12 contains a geologic map and cross sections.

— BACK OF CARD.

Texas, Arkansas, Indian Territory, Cretaceous, Eocene, Pleistocene, Paleontology (Cretaceous), Physiographic geology.

The work has been conducted along with other office work, and hence only an approximation as to the length of time required to complete a year's bibliography of this kind can be made. It is believed that from four to five months' time of one person will be required to examine the literature, prepare the manuscript and read the proof. With skilled clerical assistance much more could be accomplished in the same time.

F. B. WEEKS.

U. S. GEOLOGICAL SURVEY.

VOLCANIC DUST.

SEVERAL notices of volcanic dust have appeared recently in SCIENCE. It may be interesting, perhaps, to some of the readers of SCIENCE to learn that a large deposit of volcanic dust occurs in central Kansas, in McPherson Co., just north of the watershed between the Smoky Hill and Little Arkansas, and in the great depression extending from Salina to the Little Arkansas.

The deposit has been noted by J. A. Udden, in the *American Geologist*, June, 1891.

I have examined the deposit at various points of exposure, the extreme points being about fifteen miles apart. The deposit where noted is from two to four feet in thickness. It rests on a bed of clay and is overlaid by a bed of yellow marl. The altitude of the exposures varies perhaps forty or fifty feet. At the lowest point the dust is well assorted and stratified; at the higher points it shows signs of having been deposited in shallow water.

During the past winter I had Mr. Jas. Gilbert, a candidate for a higher degree at the Kansas State University, and former pupil of mine, make an analysis of some samples of the volcanic dust. The following is the result :

| | |
|---|--------|
| Si O ₂ and insoluble residue | 92.32— |
| Fe ₂ O ₃ , Al ₂ O ₃ | 2.66— |
| CaO | .60— |
| Mg O | 2.88— |
| H ₂ O | 1.22— |
| Traces of P, CO ₂ , Cl, Na, K. | |

Under the microscope it is found to consist almost wholly of microscopic, transparent, silicious flakes of various irregular forms. The most common forms being curved and nearly triangular. How did so large a deposit of volcanic dust reach central Kansas? H. J. HARNLY.

McPHERSON, KANSAS.

SCIENTIFIC LITERATURE.

Zur Psychologie des Schreibens mit besonderer Rücksicht auf individuelle Verschiedenheiten der Handschriften. Von W. PREYER. Mit mehr als 200 Schriftproben im Text nebst 8 Diagrammen und 9 Tafeln. Hamburg und Leipzig, Leopold Voss. 1895. 230 pp. with index.

The writer of the following lines approached the object of reviewing this book with German seriousness and with a deter-

mination to do justice. It is not always easy to do justice to a German book written with a serious purpose, because one is invariably entangled in a maze of details from which it is impossible to be free without incurring the reproval of neglecting some part of the argument. Yet the details are multiplied, like the testimony in the Roger Tichborne case, until one is simply drowned in them without being convinced of their relevancy. These remarks apply rather to those cases where German perseverance and German accuracy are enlisted in transcendental or speculative philosophy than to the discussions of exact science, where these Teutonic virtues evolve models of correct procedure. German 'Genauigkeit' applied to chimeras is like the application of the Lick telescope to the determination of the longitude of a cloud, or the application of the fine grinding mill, to which Huxley compared mathematics, to the reduction of worthless material. His apothegm, it will be remembered, was that however perfect the treatment, the value of what you got out depended upon the value of what you put in. Let us examine the book before us more attentively.

The work consists of 223 pages of text divided into five chapters and an appendix of three pages (of which more presently) on the relations of Goethe, Lavater and graphology reciprocally.

The subjects treated are as follows:

Chapter I. Wherein do handwritings differ from each other?

Chapter II. How do differences of handwriting arise?

Chapter III. Analysis and synthesis of handwriting.

Chapter IV. The significance of individual characteristics of writing.

Chapter V. Concerning the pathology of writing.

Appendix. The beginnings of graphology with Goethe and Lavater.

Alphabetical Index. Six pages.

Nine tables.

Besides these there is an introduction of four pages not enumerated. In this we became acquainted with 'Prof. Dr. W. Preyer,' written in three different styles, which we are asked to accept as typical English, French and Italian hands. We cannot do so. There are certain peculiarities of each writer manifest, but whether one considers each letter separately, or 'all together,' it is more than doubtful if a conscientious expert could assign the nationality of each writer without further help than the writing only. This national character, we are told, changes with the centuries. Another set of examples are given to show that the commercial differs from the scholarly handwriting. Again we acknowledge the differences between the specimens, but are compelled to reject the conclusions as to class, always conceding, however, that the specimen he calls typical is perfectly consistent with the popular idea of the character of the class in which he puts it.

Thus early in the book it begins to appear that our German author is committing the un-German fault of reaching conclusions through a defective second premise. This fault is the keynote to the entire treatise and it seems to us the keystone of the entire structure which Herr Preyer has built. In the first chapter he has richly illustrated platitudes such as 'the differences which belong to the standpoint of the observer,' 'Writings may be distinct and strong yet legible, etc.' In some cases the classification seems puerile; as, for instance, when it is proposed to count in 100 words how many curves occur where angles should be and *vice versa*, and to consider the percentage of both kinds of faults as an element of judging of the psychological condition of the writer (Chap. I., p. 8), or where it is proposed to draw the radii of a circle

on a sheet of glass ('or transparent paper, where great accuracy (!) is not necessary') in order to measure the slopes of letters (Chap. III., p. 47+). It would seem from this last ingenuous remark that the common horn protractor was unknown to Herr Preyer. He divides Chapter IV. into: (1) this form of the writers' characters; (2) the junction of the letters with each other; (3) the completeness of the copy (*i. e.*, the absence of gaps where letters, words or their abbreviations should be); (4) the size of the characters; (6) the direction of the component character of the writing; (7) the direction of the lines; (8) the length of the lines; (9) the distance apart of the letters, words and lines; (10) the flourish under the name.

This chapter takes up 149 pages, or much more than half the book, which latter may be considered to have been constructed around it, as the Atlanta has been said by her constructor, Charles Cramp, to be a hull constructed around a pair of boilers.

The last chapter on the Pathology of Handwriting is rather on the indications of the moods of the writer, and has the fault of the rest of the book, superficiality.

But, as if it were not possible for a German in earnest (as Herr Preyer evidently is) to completely belie the system and scrupulousness which have made the German scientific literature absolutely indispensable to any worker, he displays his faults of method completely in his appendix. The questions here are: Did Goethe believe in graphology? Did he invent it and suggest it to Lavater or not?

Out of a large mass of erudite citations showing commendable industry and intelligence, the reader who strips the verbiage from the idea conveyed discovers that there is not a scintilla of proof that Goethe ever seriously maintained that one's character could be discovered by his handwriting. Suphan thinks that Goethe probably was

much interested in the expression (*i. e.*, the formation) of the hand in Lavater's 'Physiognomische Fragmente.' In a mass of literature Herr Preyer fails to find either what would affirm or deny that Goethe had originally conceived the idea and written to Lavater of it. After all, he thinks Goethe might have imparted this orally to Lavater, and he still clings to the belief that the tradition is true which ascribes to Goethe the belief that actually men could be judged by their handwriting.

This lame and nonsequitur logic is unfortunately applied throughout the book, and mars its value to an earnest student, in spite of the exceedingly good and faithfully executed illustrations. In fact, these latter not infrequently produce the effect on the reader which a series of splendid stereopticon views of Paris would exercise on an audience listening to a lecture on chiromancy.

Professor Preyer's treatment of his subject is infinitely more serious and heavy, but not nearly as amusing and plausible as that of Don Felix de Salamanca (Chatto & Windus, Piccadilly, London, 1879, The Mayfair Library) in 'The Philosophy of Handwriting,' or, in other words, graphology. (Don Felix, for some reason, insists on calling this chiromancy, which is generally understood to be palmistry.) It is probable that Preyer was familiar with this work from the similarity of expressions which occur in the two, thus Don Felix says (p. 7): "A strong resemblance is oftimes discernible between the handwritings of various members of a family," etc. Preyer says: "Dasselbe gilt von der Aehnlichkeit der Eltern und Kinder, der Geschwister untereinander. Ein Familientypus der Schrift, wie ein solcher des Ganges oder der Mimik und Sprechweise tritt, oft deutlich zu Tage" (p. 3). Salamanca observes: "Indeed, it is not overstraining the limits of this theme to assert that not only are the idiosyncrasies of individual scribes proclaimed by their

penmanship, but even the peculiarities of whole nations" (p. 7). Preyer puts it: "Denn so wie es Nationalphysiognomien, Nationaltrachten, nationale Geberden giebt, giebt es auch Nationalhandschriften" (Einleitung, p. 1).

In spite of the fact that the earlier author betrays (quite unconsciously) as thorough a knowledge of the bibliography of the subject, and maintains equally with his German follower a belief in his ability to reach some traits of a man's character through his handwriting, yet he does not push this airy fancy to the extreme limits of absurdity by pretending it can take the place of the ordinary and slower methods of observation and experience.

To sum up Professor Preyer's claims to merit in his book: He has industry, accurate illustrations and truthfulness in statement to his credit; but on the other side of the ledger are lack of logical method, discursiveness, and predominance of the unscientific imagination.

There is some truth in his main contention, *i. e.*, that a handwriting is influenced by the character of its author. It is equally true that the appearance of the creases and worn parts of a pair of old shoes is also indicative of the character of the wearer; but neither is able, in this matter-of-fact world of ours, apart from the dream land of Sherlock Holmes et id omne genus, to give a truth-loving student the means of attaining to more than the vaguest knowledge of the character of the individual to whom it owes its existence.

It is unfortunate at this time, when an honest effort is being made to extract from handwriting certain legitimate information of value to the courts of law, that these fanciful productions should appear, with the result of confusing the layman as to their respective objects very much as astrology and astronomy were once confounded by laymen of yore. PERSIFOR FRAZER.

The Natural History of Aquatic Insects. By PROFESSOR L. C. MIALL, F. R. S., with illustrations by A. R. HAMMOND, F. L. S. London, Macmillan. 1895. 8°.

Professor Miall has given us an excellent book. He has passed in review the life histories and particularly the larval life of most of the commoner and many of the rarer forms of aquatic insects of Great Britain, and supplemented his own story of their structure, contrivances and mode of life by liberal extracts from the renowned but too neglected works of Réaumur, Lyonnet, DeGeer and Swammerdam, reviving a genuine interest in their virgin discoveries, often since repeated. He has brought to bear upon his study the equipment of a naturalist well trained in all the modern appliances for investigation, and has thereby been able to explain better than has been done before the operation of the varied mechanisms by which insects properly and originally terrestrial (as he insists) have become fitted for a more or less prolonged subaqueous life.

The work is written in a very simple and clear style, which he seems to have caught, as it were, from the older and now classical writers upon these topics. By the aid of the excellent and abundant illustrations, the most abstruse parts (if there may be said to be any such) are made comprehensible to any bright boy's intelligence, and will make him wish to set up an aquarium forthwith.

There is the meagrest possible reference to American insects, and the way is therefore open to one of our own entomologists to follow Mr. Miall's example and give us something of personal study in the same ample field, supplemented by the scattered accounts that already exist; unless, however, he follows our author's example and familiarizes himself at first hand with a large number of varied forms, he will produce but an indifferent work. Meanwhile the present volume will admirably

serve as a guide to any young entomologist, for it deals with forms almost all of which have their close counterpart in the life of our ponds and streams.

The book is excellently printed; in reading it through we have noticed but a single typographical error, where (p. 347) Heteroptera is printed Heteropoda.

S. H. S.

The Butterflies and Moths of Teneriffe. Mrs HOLT WHITE. London, L. Reeve & Co. 1894. pp. 9 + 107, 4 colored plates.

Mrs. Holt White, a connection by marriage of Gilbert White, of Selborne, spent the winter of 1892-93 in Teneriffe, and has published the result of her observations on the lepidopterous fauna of the island in a popular and unpretending volume.

The introductory chapter sketching briefly the characters and life histories of the Lepidoptera, though the least satisfactory part of the book, is not likely to mislead, and may readily be improved in a future edition, which will surely be called for; the hints and suggestions, and the directions for the killing, setting and relaxing of specimens are generally good, though here the main point to be gained is always experience.

Twenty-nine butterflies and thirty-four moths are briefly characterized, and there are frequent notes on their comparative abundance, habits, early stages and food-plants. In addition to the above, there is a list of twenty-eight moths, most of them recorded on the authority of Alphéraky in his paper, 'Zur Lepidopteren-Fauna von Teneriffa,' in the fifth volume of Romanoff's magnificent *Mémoires sur les Lépidoptères*; these, principally microlepidoptera, are considered by Mrs. Holt White as of little interest to the ordinary collector.

The four plates give good, recognizable figures of twenty butterflies and eleven moths; the coloring, though in some cases somewhat rough, is always effective.

The object of the book, to give an account of the Lepidoptera of Tenerife which will enable students to identify their specimens, is certainly accomplished. Another edition should be enlarged to include brief descriptions and, if possible, figures of all the moths known to occur in Tenerife. The systematic arrangement of the moths in the text should also be revised to correspond with that of the list.

SAMUEL HENSHAW.

A Treatise on the Morphology of Crystals. By N. STORY-MASKELYNE, M. A., F. R. S., Professor of Mineralogy, Oxford. Octavo xii.+521. New York, Macmillan & Co. 1895. \$3.50.

Although the constancy of angle between like planes of crystals furnishes the basis for a purely mathematical treatment, students in mineralogy, chemistry and petrology, to whom some knowledge of crystallography is essential, have rarely had the high mathematical training essential to the understanding of works like those of Liebig, Mallard or Klein, and they will appreciate this treatise of the veteran Oxford professor, in which the principles and problems of crystallography are designedly treated in the 'simplest form compatible with strict geometrical methods.'

The work deals solely with the morphology of crystals, and is to be followed by a volume treating, in a similar manner, the physical problems necessary to a thorough knowledge of crystallography. After a brief statement of the general properties of crystals, especially the physical characters, the author proceeds to the logical development of his subject. The expressions for the position of a plane and of an origin-edge or zone axis are first deduced and the principles of stereographic projection clearly and simply stated. The practical application of the stereographic projection is then made possible by the solving of cer-

tain problems, such as: 'Given the projection of a great circle, to find that of its pole;' 'To determine the magnitude of an arc of a great circle from the projection of that arc;' 'To draw the projection of a great circle in which two points are given,' etc.

The properties of zones, the relation connecting tautozonal planes and the relations between edges and normals are examined, and the necessary expressions deduced by purely geometrical methods and also by the methods of analytical geometry. Preliminary to a discussion of symmetry, it is clearly brought out that the only angles possible between consecutive normals in isogonal zones are 90° , 60° , 45° and 30° .

Chapter IV. deduces expressions for changing parametral planes and axes, and proves that axes are not arbitrary diametral lines but are necessarily origin edges or face normals.

The possible varieties of symmetry, holo and mero, and composite and twin crystals, are elaborately treated. The author's wording of the law of symmetry or second fundamental law of crystallography is new and very thorough. "On a crystal the extant or absent features of a form must be extant or absent in the same way in respect to equivalent systematic* planes." The six systems are separately considered each under the headings: holosymmetrical forms, hemisymmetrical forms, combinations of forms, and twinned forms. The balance of the book is taken up with methods of measurement, calculation and representation.

The work is clearly printed and the diagrams are well conceived. The mathematical deductions can usually be followed by any one with a working knowledge of geometry and analytical geometry. The statements and definitions are very exact but not always concise. For instance, the definitions of a crystalloid system of planes

*Planes of symmetry.

is one sentence of eighty-five words (p. 23). There is no doubt that the work is in every way one of great value to students.

A. J. MOSES.

SCIENTIFIC JOURNALS.

THE ASTROPHYSICAL JOURNAL, JUNE.

The Measurement of Some Standard Wave-Length in the Infra-red Spectra of the Elements: EXUM PERCIVAL LEWIS.

In a review of the previous work in this field, the writer shows that very little has been done toward the identification and accurate measurement of lines due to the elements in the infra-red, and that the means employed have been comparatively crude. In the present investigation, a grating of high dispersive power was combined with the radiomicrometer, which was found to be more reliable and of greater sensitiveness than the bolometer. Results are given for sodium, lithium, silver and calcium lines.

On the Distribution in Latitude of Solar Phenomena Observed at the Royal Observatory of the Roman College in 1894: P. TACCHINI.

The faculæ and spots of 1894, and especially the prominences, have been markedly more frequent in the southern hemisphere, like similar phenomena since the summer of 1892.

A Review of the Spectroscopic Observations of Mars. W. W. CAMPBELL.

The writer replies to some critics of his former paper on the spectrum of Mars, and makes a critical examination of previous work along this line. He concludes that many of the former observations were made under circumstances extremely unfavorable, and that between the different sets of results there is not a satisfactory close agreement.

Preliminary Table of Solar Spectrum Wave-Lengths. VI. H. A. ROWLAND.

The table is continued from λ 4674.648 to λ 4903.502.

On the Electromagnetic Nature of the Solar Radiation and on a New Determination of the Temperature of the Sun. H. EBERT.

A comparison of the form of the solar energy curve with that of a strongly damped electric oscillator shows that in sunlight we are dealing with electromagnetic vibrations. But with respect to electromagnetic radiation the principal mass of the Sun acts like a black body. Hence, applying Rubens' formula for the maximum energy of the radiation of blackened bodies, $\lambda \sqrt{T} = 123$, and using 0.6μ for the value of λ as found by Langley for the maximum energy of the solar spectrum, a temperature of $40,000^\circ$ C. is found for the more interior regions of the Sun. This is in good agreement with values previously determined by other methods.

Photographs of the Milky-Way near 15 Monoceros and near ϵ Cygni: E. E. BARNARD.

On the Limit of Visibility of Fine Lines in a Telescope: ALBERT A. MICHELSON.

A theoretical discussion proves that a line subtending an angle of one-fiftieth of the limit of resolution may be distinctly seen. This is verified by experiment and applied to the 'canals' on Mars. Supposing them to be quite dark, and distinguishable by an objective of not less than eighteen inches aperture, their width is calculated to be about one mile.

Conditions affecting the Form of Lines in the Spectrum of Saturn: JAMES E. KEELER.

The effects of instrumental displacements are considered, limiting the question to the case where the slit is parallel to the major axis of the ring.

A displacement of the image at right angles to the slit gives a disproportionate exposure to the middle parts of the lines, but unless the displacement exceeds one-fourth the semi-axis minor, there is scarcely any change in direction produced. A drift in the direction of the slit broadens the

lines uniformly. In every case, displacements tend to make the spectra of the ansæ parallel to the undisplaced lines of the comparison spectrum.

MINOR CONTRIBUTIONS AND NOTES.

Notes on Schmidt's Theory of the Sun.

Note on the Yerkes Observatory.

On the Presence of Helium in Cléville.

Note on the Huggins Method of Photographing the Solar Corona without an Eclipse.

On the Cause of Granulation of the Surface of the Sun.

The illustrations of special interest are the two plates accompanying Professor Barnard's article, and a photographic reproduction of a water-color sketch of the Yerkes Observatory as it will appear when finished.

THE AMERICAN NATURALIST.

THE number for June opens with an article by Professor E. H. Barbour, of the University of Nebraska, on *Dæmonelix*, or the 'Devil's Corkscrew,' described by him in 1892. It is a reply to Dr. Theodor Fuchs, who has argued that this curious fossil is the burrow of a Miocene rodent. Professor Barbour holds that this is impossible, owing to the fact that the 'Bad Lands,' in which the fossils occur, are not wind deposits but water deposits, and for other reasons that he adduces. Dr. T. H. Montgomery in an article *On Successive Protandric and Proterogynic Hermaphroditism in Animals*, with a bibliography of 48 titles, concludes that hermaphroditism has been evolved out of the female state in all proterogynic forms, but that in the case of protandric forms it has been superimposed on the male sex. Articles follow by Dr. Joseph F. James on *Sponges, Recent and Fossil*, and by Mr. V. L. Kellogg on *The Mouth Parts of Lepidoptera*, both articles being illustrated. Dr. James points out the wide distribution of sponges in time and space, and, quoting from Sollas similarities in apparently unrelated families, concludes that forms now supposed to be

genetically related may have been of distinct origin. Mr. Kellogg argues that the commonly accepted view that the mouth parts of the Lepidoptera are of a type adapted for sucking and that mandibles are wanting or rudimentary is not true without qualification. More than half of the number is occupied with notes and reviews on the progress of the several natural sciences.

NEW BOOKS.

Leitfaden für Histologische Untersuchungen.

BERNHARD RAWITZ. Jena, Gustav Fischer. 1895. Pp. xiii+148. M. 3.

Pflanzen Physiologische Praktikum. W. DETMER. Jena, Gustav Fischer. 1895. Pp. xvi+456. M. 9.

Untersuchungen über die Stärkekörner. ARTHUR MAYER. Jena, Gustav Fischer. 1895. Pp. xvi+318. M. 20.

Ueber die Auslese in der Erdgeschichte. JOHANNES WALTHER. Jena, Gustav Fischer. 1895. Pp. 36. 80 Pt..

Die Emancipation in der Ehe. FELICIE EWART. Hamburg and Leipzig, Leopold Voss. 1895. Pp. 75. M. 1.

Chinook Texts. FRANZ BOAS. Washington. 1894. Pp. 278.

A Text-Book of Zoögeography. FRANK E. BEDDARD. Cambridge, University Press. New York, Macmillan & Co. 1895. Pp. 8+246. \$1.60.

The Natural History of Aquatic Insects. L. C. MIALL. London and New York, Macmillan & Co. 1895. Pp. ix+395. \$1.75.

Electricity up to Date. JOHN B. VERITY. London and New York, Frederick Warne & Co. 1893. xii+226. 75 cents.

Algebra for Beginners. By H. S. HALL and S. R. KNIGHT. Revised by Frank L. Sevenoak. New York, Macmillan & Co. 1895. Pp. viii+180. 60 cents.

Report of the Secretary of Agriculture. Washington, D. C. 1895. Pp. 220.

SCIENCE

NEW SERIES.
VOL. II. No. 30.

FRIDAY, JULY 26, 1895.

SINGLE COPIES, 15 CTS.
ANNUAL SUBSCRIPTION, \$5.00.

GUSTAV E. STECHERT'S

Recent Importation of Scientific Books.

BECKER, DR. W. J. von. Hygienische Meteorologie. Für Aerzte und Naturforscher. Mit 42 in den Text gedruckten Abbildungen. 8°. M. 8.

BERGH, DR. R. S. Vorlesungen über allgemeine Embryologie. Mit 126 Figuren im Text. 289 Seiten. Gross 8°. M. 7.

DAMMER, DR. O. Handbuch der chemischen Technologie. Unter Mitwirkung von Th. Beckert, Dr. Bender, Dr. Benedict, Dr. Börnstein, u. A. Band I. Mit 191 in den Text gedruckten Figuren. gr. 8°. M. 24.

HANDWÖRTERBUCH DER ASTRONOMIE, Unter Mitwirkung mehrerer Professoren, herausgegeben von Prof. Dr. W. Valentiner. Mit Abbildungen. Lieferung 1. 128 Seiten. Gross 8°. M. 3.60.

HARTLEBEN'S statistische Tabelle über alle Staaten der Erde. Uebersichtliche Zusammenstellung von Regierungsform, Staatsoberhaupt, Thronfolger, Flächeninhalt, absoluter und relativer Bevölkerung, Staatsfinanzen, Handelsflotte, Handel, Eisenbahnen, Telegraphen, Zahl der Postämter, Werth der Landesmünzen in deutschen Reichsmark, Gewichten, Längen und Flächenmassen, Hohlmassen, Armee, etc. M. 50 Pf.

VON JONSTORFF, HANNS FREIHERE JÜPTNER. Fortschritte im Eisenhütten-Laboratorium in den letzten 10 Jahren. Erster Band. Mit 99 Figuren. 270 Seiten. 8°. M. 8.50.

KOLBE, BRUNO. Einführung in die Electricitätslehre. Band II. Dynamische Electricität. Mit 75 in den Text gedruckten Holzschnitten. 187 Seiten. 8°. M. 3.

KRÄMER, INGENIEUR JOS. Wirkungsgrade und Kosten elektrischer und mechanischer Kraft-Transmissionen. Mit vielen Figuren, Schemata und einer Tafel. 88 Seiten. 8°. M. 3.

LEDUC, A. Manipulations de Physique Avec. 144 figures intercalées dans le texte. 392 pages. 8°. Fr. 6.

MEISSNER, G. Die Hydraulik und die hydraulischen Motoren. Ein Handbuch für Ingenieure Fabrikanten und Constructeure. Zum Gebuchera für technische Lehranstalten sowie ganz besonders zum Selbstunterricht. Zweite vollständig neu bearbeitete Auflage von Dr. H. Hederich und Ingenieur Nowak. I. Band. Die Hydraulik. Lieferung 1. 80 Seiten. 8°. M. 3.

MEYER, PROF. DR. ARTHUR. Untersuchungen über die Stärkekörner. Wesen und Lebensgeschichte der Stärkekörner der höheren Pflanzen. Mit 9 Tafeln und 99 in den Text gedruckten Abbildungen. 320 Seiten. Gross 8°. M. 20.

METZGER, PROF. DR. A., und PROF. DR. N. I. C. MÜLLER, Die Nonnenraupe und ihre Bakterien Untersuchungen ausgeführt in den zoologischen und botanischen Instituten der Königl. preuss. Forstakademie Münden. Mit 45 Tafeln in Farbendruck. 100 Seiten. 8°. M. 16.

MICHAUX, L. ET M. GILLET. Leçons élémentaires de télégraphie électrique. Système Morse-Manipulation-Notions de Physique et de Chimie-Piles-Appareils et accessoires installation des postes. 2^e édition, entièrement refondue. 232 pages. Pet. 8°. Fr. 3.75.

NI EWENGLOWSKI, PROF. B. Cours de Géométrie Analytique a l'usage des élèves de la classe de mathématiques spéciales et des candidats aux écoles du gouvernement. Tome II. Construction des Courbes planes. Compléments relatifs aux coniques. 292 pages. 8°. Fr. 8.

PRASCH, ADOLF AND HUGO WIEZT. Die elektrotechnischen Maasse. Lehrbuch zum Selbststudium. Dargestellt und durch zahlreiche Beispiele und 38 in den Text gedruckte Figuren erläutert. 153 Seiten. 8°. M. 3.00.

SCHMIDT, DR. F. W. Kurzes Lehrbuch der anorganischen Chemie. Ein Repetitorium für Chemiker, Mediciner und Pharmaceuten. 376 Seiten. 8°. M. 4.50.

VERWOEN, DR. MAX. Allgemeine Physiologie. Ein Grundriss der Lehre vom Leben. Mit 270 Abbildungen. 584 Seiten. gr. 8°. M. 15.

WASMANN, E. Kritisches Verzeichniss der Myrmekophilen und Termitophilen Arthropoden. Mit Angabe der Lebensweise und mit Beschreibung neuer Arten. 231 Seiten. gr. 8°. M. 12.

WINDRATH, DR. A. Die Medicin unter der Herrschaft des bacteriologischen Systems. 231 Seiten. 8°. M. 5.

WYSS, DR. HANS, V. Kurzes Lehrbuch der Toxicologie für Studierende der Medicin und praktische Aerzte. 212 Seiten. gr. 8°. M. 5.

WISLICENUS, PROF. DR. WALTER F. Astronomische Chronologie. Ein Hülfsbuch für Historiker, Archäologen und Astronomen. 163 Seiten. 8°. Leinwandband. M. 5.

ZICKLER, PROF. KARL. Das Universal-Elektrodynamometer. Mit 8 in den Text gedruckten Figuren. 32 Seiten. 8°. M. 1.

GUSTAV E. STECHERT,
810 Broadway, New York.

Macmillan & Co.'s New Publications.

Cambridge Natural Science Manuals. General Editor—A. E. SHIPLEY, M. A.
Fellow and Tutor of Christ's College.

NEW VOLUMES.

- I. **Elements of Botany.** By F. DARWIN, M. A., F. R. S., Fellow of Christ's College, Cambridge, and Reader of Botany in the University. With numerous illustrations. (*Biological Science.*) 12mo, \$1.60, net.
- II. **Petrology for Students.** By A. HARKER, M. A., F. G. S., Fellow of St. John's College, Cambridge University Demonstrator in Petrology. 12mo, \$2.00.
- III. **A Text-Book of Zoogeography.** By FRANK E. BEDDARD, M. A. (Oxon), F. R. S., Professor of the Zoological Society of London. Maps, 12mo, cloth, \$1.60, net. (*Biological Science.*)

The Theory of Light. By THOMAS PRESTON, M. A. (Dub.), Fellow of the Royal Society of Ireland and Professor of Natural Philosophy, University College, Dublin. 8vo, cloth, pp. xii+573, \$5.00, net.

Analytical Chemistry. By N. MENSCHUTKIN, Professor of the University of St. Petersburg. Translated from the third German edition under the supervision of the Author. By JAMES LOCKE, Assistant in the Analytical Laboratory of the University of Heidelberg. Pp. xii+512, 8vo, cloth, \$4.00, net.

Text-Book of Operative Surgery. By DR. THEODOR KOCHER, Professor of Surgery and Director of the Surgical Clinic in the University of Bern. Translated with the Special Authority of the Author from the Second Revised and Enlarged German Edition by HAROLD J. STILES, M. B., F. R. C. S., Edin., Senior Demonstrator of Surgery and formerly Demonstrator of Anatomy in the University of Edinburgh, etc. With 185 Illustrations. 8vo, cloth, pp. 303, \$3.50, net.

On Certain Phenomena belonging to the Close of the Last Geological Period, and on their bearing upon the Traditions of the Flood. By JOSEPH PRESTWICH, D. C. L. (Oxon.), F. R. S., F. G. S., Corr. Inst. France (Acad. Sc.), Acad. R. Lyncei, Rome; Roy. Acad., Brussels, etc. 8vo, cloth, pp. 87, \$1.00.

The Horticulturist's Rule-Book. A Compendium of Useful Information for Fruit-growers, Truck-gardeners, Florists and others. By L. H. BAILEY, Professor of Horticulture in Cornell University. Third Edition, thoroughly Revised and Recast, with many Additions. 12mo, limp cloth, 75 cents.

Hydrodynamics. By H. LAMB, M. A., F. R. S., Professor of Mathematics in Owens College, Manchester. Demy 8vo, cloth, \$6.25, net.

A Monograph on the Order of Oligochaeta. By FRANK EVERS BEDDARD, M. A. (Oxon.), F. R. S., Prosector to the Zoological Society of London, and Lecturer at Guy's Hospital. 4to, stiff boards, linen back, \$12.50, net.

Crystallography. A Treatise on the Morphology of Crystals. By N. STORY-MASKELYNE, M. A., F. R. S., Professor of Mineralogy, Oxford, Honorary Fellow of Wadham College. 12mo, \$3.50, net.

The Great Frozen Land (Bolshaiia Zemelskija Tundra). Narrative of a Winter Journey across the Tundras and a Sojourn among the Samoyads. By FREDERICK GEORGE JACKSON, Fellow of the Royal Geographical Society, Leader of the Jackson-Harmsworth Polar Expedition. With Illustrations and Maps. Edited from his Journals by ARTHUR MONTEFIORE, Fellow of the Geological and Royal Geographical Societies and Anthropological Institute. 8vo, cloth, pp. 297, \$4.50.

The American Commercial Policy. Three Historical Essays. By UGO RABBENO, Professor of Political Economy in the University of Modena. Second Edition. Partly rewritten and entirely revised by the author. Translated at the Translations Bureau, London. 8vo, cloth, pp. 414, \$3.25, net.

MACMILLAN & CO., 66 Fifth Avenue, New York.

SCIENCE

EDITORIAL COMMITTEE: S. NEWCOMB, Mathematics; R. S. WOODWARD, Mechanics; E. C. PICKERING, Astronomy; T. C. MENDENHALL, Physics; R. H. THURSTON, Engineering; IRA REMSEN, Chemistry; J. LE CONTE, Geology; W. M. DAVIS, Physiography; O. C. MARSH, Paleontology; W. K. BROOKS, Invertebrate Zoology; C. HART MERRIAM, Vertebrate Zoology; S. H. SCUDDER, Entomology; N. L. BRITTON, Botany; HENRY F. OSBORN, General Biology; H. P. BOWDITCH, Physiology; J. S. BILLINGS, Hygiene; J. MCKEEN CATTELL, Psychology; DANIEL G. BRINTON, J. W. POWELL, Anthropology.

FRIDAY, JULY 26, 1895.

THOMAS HENRY HUXLEY.

CONTENTS:

| | |
|--|-----|
| <i>Thomas Henry Huxley</i> | 85 |
| <i>The St. Elias Bear</i> : W. H. DALL | 87 |
| <i>The Causes of the Gulf Stream</i> : R. MEADE BACHE | 88 |
| <i>Physiology in 1894</i> | 95 |
| <i>Current Notes on Physiography (XIII)</i> :—..... | 97 |
| <i>The Catoclin Belt of Maryland and Virginia; Recent Topographical Maps; The Delaware Water Gap</i> : W. M. DAVIS. | |
| <i>Psychological Notes</i> :—..... | 99 |
| <i>The Sense of Equilibrium; Consciousness and the Origin of Species</i> : J. MCK. C. | |
| <i>Scientific Notes and News</i> :—..... | 100 |
| <i>The Parallax of Eta Cassiopeie; The Marine Biological Laboratory; The Population of France; Karl Ludwig's Library; The American Philological Association; General</i> . | |
| <i>University and Educational News</i> | 104 |
| <i>Correspondence</i> :—..... | 105 |
| <i>Balm for Wounded Authors and Proof-readers</i> : THEO. GILL. <i>The Generic Name Anisonyx Pre-occupied</i> : C. HART MERRIAM. <i>Correction</i> : EUGENE A. SMITH. | |
| <i>Scientific Literature</i> :—..... | 107 |
| <i>Angot's Les aurores polaires</i> : A. M. <i>Geological Survey of Michigan</i> : J. F. KEMP. <i>Veröffentlichungen aus dem Königlichen Museum für Völkerkunde</i> : D. G. BRINTON. | |
| <i>Societies and Academies</i> :—..... | 110 |
| <i>The Astronomical and Physical Society of Toronto</i> . | |
| <i>Scientific Journals</i> | 111 |
| <i>The American Chemical Journal</i> . | |
| <i>New Books</i> | 112 |

HUXLEY died on June 29th, having attained the age of seventy years on May 4th. His death was not unexpected, as he had been lying ill at Eastbourne for nearly four months, nor can it be regarded as premature, as his important contributions to science ceased some fifteen years ago. But the vigor of his thought and language had remained unabated, and his death, following that of Tyndall, leaves a great blank in the group of men who from England have directed the course of modern science.

Huxley made his own way, his father having been an undermaster in a school in the Middlesex village of Ealing. He became a surgeon in the navy and spent four years in a cruise in the South Seas. A sea voyage was thus the determining factor in his life, as in the case of Darwin. Several communications sent home to the Linnean Society were rejected, but in 1849 the Royal Society published his paper on the *Anatomy and Affinities of the Medusæ*, and in 1851 he was elected a fellow of the Society. He was disappointed in his hopes that the admiralty would publish his great work on *Oceanic Hydra* (which finally appeared in 1859), and resigned his position in the navy. After several failures to secure a position (he and his friend Tyndall applied unsuccessfully for vacant chairs in the University of Toronto) he succeeded Forbes in 1854 as paleontologist and professor of natural his-

MSS. intended for publication and books, etc., intended for review should be sent to the responsible editor, Prof. J. McKeen Cattell, Garrison on Hudson, N. Y.

Subscriptions and advertisements should be sent to SCIENCE, 41 N. Queen St., Lancaster, Pa., or 41 East 49th St., New York.

tory in the Royal School of Mines, and held these positions until his retirement from active work in 1885.

In the same year he was appointed Full-erian professor of physiology in the Royal Institution and examiner in physiology and comparative anatomy in the University of London. In the thirty years that followed he filled a large number of positions, some honorary and some requiring a large expenditure of time and labor. In 1858 he was Croonian lecturer to the Royal Society; from 1863 to 1869 he was professor of comparative anatomy to the Royal College of Surgeons; in 1875-6 he acted as substitute in the chair of natural history in the University of Edinburgh; from 1870-2 he was a member of the first London School Board; from 1881-5 he was inspector of salmon fisheries. He was Lord Rector of the University of Aberdeen, president of the Geological and Ethnological Societies, president of the British Association, and secretary and president of the Royal Society. He received degrees from Oxford, Cambridge, Edinburgh, Dublin, Würzburg and Breslau, and was a member of the leading scientific societies and academies of the world.

Owing to failing health—his heart was affected—Huxley retired from active work in 1885, and latterly had been living by the sea. He suffered from an attack of influenza early in March, from which he did not recover, and finally succumbed to cardiac and pulmonary complications. He was interred on July 4th, in Marylebone cemetery, Finchley, where his eldest son lies buried. His wife, three sons and four daughters survive him.

Huxley's zoological writings cover the whole range of the science from the protozoa to man, including an equal consideration of living and extinct species. But his interests and publications were by no means confined to zoology. He wrote excellent introductions to physiology and phys-

iography. He discussed many problems, from Hume's philosophical scepticism to the 'Salvation Army.' Indeed, his original contributions to zoology are at present overshadowed by his fame as a teacher and advocate. Perhaps he would himself have regretted this. He wrote in 1894 (referring doubtless to Tyndall): "At the same time it must be admitted that the popularization of science, whether by lecture or essay, has its drawbacks. Success in this department has its perils for those who succeed. The 'people who fail' take their revenge, as we have recently had occasion to observe, by ignoring all the rest of a man's work and glibly labelling him a mere popularizer."

But Huxley was undoubtedly fitted for the work he accomplished. His thought was clear and his character forcible, and these are admirably reflected in his language. It may seem to us that the batteries are needlessly heavy in view of the defences, but there is truth in what he said with not uncharacteristic self-assertion—his work has been 'inclosed among the rubble of the foundations of later knowledge.' Huxley has described what he aimed to do and what he accomplished better than another can—he wrote:

"To promote the increase of natural knowledge and to forward the application of scientific methods of investigation to all the problems of life to the best of my ability, in the conviction which has grown with my growth and strengthened with my strength that there is no alleviation for the sufferings of mankind except veracity of thought and of action, and the resolute facing of the world as it is when the garment of make-believe by which pious hands have hidden its uglier features is stripped off. It is with this intent that I have subordinated any reasonable, or unreasonable, ambition for scientific fame, which I may have permitted myself to entertain, to other ends; to the popularization of science; to the development and organization of scientific education; to the endless series of battles and skirmishes over evolution; and to untiring opposition to that ecclesiastical spirit, that clericalism, which in England, as everywhere else, and to whatever denomination it

may belong, is the deadly enemy of science. In striving for the attainment of these objects, I have been but one among many, and I shall be well content to be remembered, or even not remembered, as such."

THE ST. ELIAS BEAR.

A BEAR has been for some time reported as frequenting the vicinity of the glaciers of the St. Elias Alpine region, which is regarded by the Indians and hunters as a distinct species from either the black or the large brown bear of Alaska. It is of moderate size, the largest skins not exceeding six feet in length, and is reported to be shy and less fierce than either of the others. The examination of four well preserved trapper's skins of this animal in the possession of Major Turner, of Sitka, has convinced me that we have to do with an animal which is unlike either of the common bears of the region, and specifically distinct from the brown bear of Alaska, which has been cited of late under the name of *Ursus Richardsonii* of Mayne Reid, though perhaps forming a separate race from the typical Barren Ground bear. Whether the St. Elias bear forms a distinct species from the black bear is doubtful, but it is at least a well defined local race, to which I have seen no approximation among the thousands of black bear skins which I have examined in past years in the hands of traders in this Territory. As such it seems desirable to call attention to it by such a description as is practicable at this time.

The general color of the animal resembles that of a silver fox. The fur is not very long, but remarkably soft and with a rich under fur of a bluish black shade, numbers of the longer hairs being white, or having the distal half white and the basal part slaty. The dorsal line from the tip of the nose to the rump, the back of the very short ears, and the outer faces of the limbs, are jet black. Numerous long white hairs issue from the ears; black and silver is the prevalent pelage

of the sides, neck and rump; the under surface of the belly and the sinuses behind the limbs are grayish white, or even nearly pure white, I am told, in some cases. The sides of the muzzle and the lower anterior part of the cheeks are of a bright tan color, a character I have not seen in any other American bear; and this character is said to be invariable. There is no tint of brown elsewhere in the pelage. There is no tail visible on the pelts. The claws are small, very much curved, sharp, black above and lighter below; the animal evidently can climb trees, which the brown bear cannot do.

This bear is known to range about the St. Elias glaciers, especially near Yakutat, and a single specimen has been killed on the mountains as far east as Jureau. About thirty-five skins have been brought to Sitka, mostly from Yakutat. A mounted skin, the only one known as yet (said to contain the skull), is in the possession of Mr. Frank A. Bartlett, of Port Townsend, Wash.

My attention was called to this animal by Lieut. G. T. Emmons, U. S. N., well known in connection with the fine collection of Alaskan ethnology in the American Museum of New York; and I would suggest the varietal name of *Emmonsii* for the St. Elias bear. It is also known among the fur dealers here as the Glacier, or the Blue bear. I hope to be able to secure specimens of the skin and skull for the National Museum, through the Yakutat hunters, later.

It is worthy of note that the Indians report another animal unknown to naturalists, on the higher mountains of the mainland. It is said to resemble the mountain sheep and to have horns nearly as long but almost straight, like those of an ibex. Lieut. Emmons is confident that these reports have a basis in fact.

WM. H. DALL.

SITKA, ALASKA, June 28, 1895.

THE CAUSES OF THE GULF STREAM.

SHORTLY after the first voyage of Columbus, the existence and some of the characteristics of the Gulf Stream became known, and with Franklin's experiments as to its temperature, scientific observations upon it began. Since then, many other observations as to its depths in places, temperature and direction have been added to the sum of information on the subject, knowledge of which, in the form of scientific reports, monographs and magazine articles, has more or less found its way to the public; some of the accounts, however, stopping very far short of the ultimate interest in the subject derivable from determination of the causes of the stream. The statement that the trade winds heap up the equatorial waters on the eastern shore of Central America, thereby giving a 'head' to the Carribean Sea and the Gulf of Mexico, seems to suffice to most persons for an all-sufficient explanation of the generation and behavior of the Gulf Stream. But it ought to be obvious that, although winds do, as is observable in small areas, heap up waters against obstructive lines upon which they impinge, the movement of the equatorial waters towards the west cannot be the sole cause of the Gulf Stream. On the contrary, whatever head actually exists there is produced by several agencies causing the thrust of waters in the form of a mighty current.

Seeking for a single cause of the phenomena, one will be foiled. He would make an attempt at the bottom of much unproductiveness in research, arising from seeking in nature for some one cause to account for any phenomenon in its entirety. In seeking, therefore, for the cause of the Gulf Stream, we must resolve the idea of cause into that of causes, called, if one will, primary, secondary, etc., but still, in the aggregate, activities of many existing conditions. These are the globular form of the earth;

its rotation on its axis; the difference, in correspondence with latitude, of its rotary velocity; the difference in temperature, involving density, between polar and equatorial waters; the direction and force of the trade winds; the head of water produced by those winds and other agencies at the the Gulf Stream, and the correspondingly lower level at the places whence a portion of its waters are so derived; the volume of discharge contributed to the Carribean Sea and the Gulf of Mexico by the rivers flowing into them; the increase in volume of those waters through the long continued heat to which they are subjected while confined within the caldron formed by those basins—these, and nothing less, represent in fact the assemblage of the causes of the Gulf Stream.

The Coast and Geodetic Survey of the United States has, within the last few years, made very valuable additions to knowledge of the Gulf Stream, through the investigations of Lieutenant Pillsbury, of the Navy, commanding the steamer *Blake*, but these relate to details, which although interesting, do not involve the largest question relating to the stream in its very existence. Lieutenant Pillsbury established the fact of the absence of the supposed hill ranges, in and parallel to the trough in which the stream for a while flows in its course along the shores of the United States; the indeterminateness of the position of its boundary line, constituted by Arctic water lying between it and the coast, well described by the term 'cold wall,' and he also proved the indeterminateness of the bands of alternating warm and cold water in the stream, caused by the irregular dispersion of surface water by winds. The impossibility of recognizing at all times by temperature the position of the axis of movement of the stream is thus clearly shown. He discovered fluctuations in the stream, in direction and strength, as dependent upon the

position of the moon; and the influence of the pressure of the atmosphere over large conterminous areas of high and low barometer, in accelerating or retarding the current. He also determined the presence of a fringe of current on the east of the Gulf Stream proper, proceeding at a slower rate than it, and conformably in direction. These and other points make a very interesting series of discoveries, but they do not touch the causes of the Gulf Stream. They relate solely to the agencies which modify it. Were all these conditions absent, the Gulf Stream, merely as a body of water flowing in the direction which it now pursues, would still exist substantially as at present.

In the particular not relating to influences merely modifying the stream, but to the question how such portion of its waters as have passed into the Caribbean Sea and the Gulf of Mexico, under the influence of the trade winds, have been translated thither, the present writer cannot agree with Lieutenant Pillsbury. For, whereas Lieutenant Pillsbury's observations at the Windward Islands show, as their result, that the water there entering the Caribbean Sea, as a current, represents only about half of the volume which he determined as flowing out of the Straits of Florida, as the Gulf Stream, he accounts for the other half by supposing that, in addition to the flow into the Caribbean Sea at the Windward Islands, a great amount is also delivered there by the toppling of the seas towards the west as they roll on towards and through the passages between the islands. That any force of wind, however great or small, could be resolved, on the one hand into a current, and on the other into waves, and the volume of the latter be available in helping to fill an interior basin through openings of an archipelago, does not agree with dynamic laws known and admitted. Toppling seas proceeding in any given direction resolve

themselves into and quicken current; in fact, current in water, as derived from wind, is conditioned upon the ruffling of the surface, whether in the form of a ripple or a billow. Therefore current and wave are not dynamically separable as agencies of transportation. It follows that, if the Windward Islands' observations show only about half the volume of water delivered into the Atlantic by the Gulf Stream, the remainder is chiefly to be accounted for by a volume of the polar current under-running, and running by the sides of the Straits of Florida. Plus the other supplies already mentioned, and minus evaporation, we have then the sum-total volume of water with which nature is dealing in the production of the stream.

The primary causes of the Gulf Stream are the rotation of the earth, the difference of density between its polar and equatorial water, and the presence of the American continent. For, if we will eliminate in imagination every agency but these, including the trade winds, we shall see that we have, through the facts of the form of the earth and this difference of density, the resultant of two lines of force represented by the tendency in the direction of waters so constituted to flow. On one of these the centrifugal force of the earth's rotation draws the waters as a sub-marine flow from the poles to the equator, resulting in a supra-marine flow from the equator to the poles; while, on the other, the rotation of the earth on its axis, at right angles to those directions, tends to make the waters move directly towards the east. If there were no continents at all on the surface of the earth, the effect of this, as viewed from the equator, would be to make the sub-marine flow from the pole, in the northern hemisphere, assume a southwesterly curve convex towards the equator; and to make the supra-marine flow, from the equator to the same pole, assume a northeasterly

curve, concave towards the equator. Similarly, with reference to the southern hemisphere, as viewed from the equator, the sub-marine flow from the pole would assume a northwesterly curve, convex towards the equator, and the supra-marine flow from the equator to the pole would assume a southeasterly curve, concave towards the equator. The reason for this is that the sub-marine flow, coming from the north or the south pole, would reach successively degrees of latitude of greater and greater velocity of rotation, and therefore would assume a more and more westerly direction, whereas the flow going from the equator towards either pole would successively reach degrees of latitude of less and less velocity of rotation, and therefore would assume a more easterly direction.

The very same causes are operative now to produce the very same effect, and the chief reason that it does not exist in the simplicity described is on account of the presence of continental lines disposed in a northerly and southerly direction. Yet, despite the complication thereby introduced into the phenomenon of ocean movement by that and other causes, the surface waters of the ocean, without regard to the streams coursing through them, move in a general direction in the northern hemisphere towards the northeast, and the sub-marine waters towards the southwest; while, in the southern hemisphere, they move correspondingly, the surface waters towards the southeast, and the sub-marine waters towards the northwest. Owing to the causes which have now been detailed at sufficient length, the sub-marine waters lag behind the surface waters, and therefore the surface flow from the equator to the poles assumes a relatively easterly position with respect to the sub-marine flow from the poles to the equator. The inclusion of the agency of the north and south continental lines, and the presence of constant winds

in certain quarters of the earth, do not create the movements of the oceans, but merely serve to modify with great intricacy the general flow.

The movements just described as deducible from general principles, and long previously held to be true, have in quite recent times been proved true by various scientific observations, notably by those of the British ship *Challenger*, Captain Nares, in 1873-1876. Having thus settled once for all in our minds that the primary cause of the Gulf Stream is not the influence of the trade winds, to which it has long been ascribed, but that it is derived from causes which were the basis of theory broached many years ago, the correctness of which is fully established, let us proceed to introduce for the completed phenomenon the chief subsidiary agencies which make the Gulf Stream what it is as observed.

The Equatorial Current is known technically as a drift current, that is, one formed by the friction of the wind on the surface of water. The Equatorial Current is, in consequence, not a deep current. According to Sir Charles Wyville Thomson, scientific director of the *Challenger* expedition, its movement does not reach below fifty fathoms in depth. Moreover, it is not, as commonly spoken of, a single current, but is divided into a northern and a southern stream. The thermal equator does not coincide exactly with the geographical equator, but lies two or three degrees north of it. In consequence, as the trade winds, the cause of the Equatorial Currents, blow from the northeast and southeast, the position of those winds is determined by that of the thermal equator, and the whole equatorial system of winds and currents tends more to the north than to the south of the equator, the southern limit of the northeast trade winds, with the southern declination of the sun, not reaching, by two or three degrees, to the geographical equator, while,

on the contrary, the northern limit of the southeast trade winds sometimes passes, with the northern declination of the sun, as much as five degrees above the geographical equator. Between these two currents, whose north and south limits are respectively above the line of the Tropic of Cancer and below that of the Tropic of Capricorn, depending upon the annual declination of the sun, and always ranging higher above the Tropic of Cancer than below the Tropic of Capricorn, lies the region of equatorial calms, squalls and variable winds, called by sailors the doldrums, within whose eastern area a counter current, of length varying according to the season, contributes to the Guinea Current on the coast of Africa, also contributed to by the cool southerly current along the northwest coast of Africa, called the North African Current.

It will readily be seen from the above statement and from examination of the map of the Atlantic that, during the summer season of the northern hemisphere, the largest contribution by the Equatorial Currents must be made to the Gulf Stream, for not only is the whole of the North Equatorial Current then, as always, north of the equator, but the South Equatorial Current not only overlaps the equator, but extends then for some distance to the southward in a favorable position for the entrance of much of its water, deflected to the northwest by Cape Roque, and then known as the Guiana Current, to enter the Caribbean Sea. In both seasons the Atlantic northern hemisphere must therefore receive and deliver from near the equator a larger supply of surface-moving water than the southern Atlantic hemisphere ever thence receives and delivers. The slower current in the same direction, on the eastern edge of the Gulf Stream mentioned by Lieutenant Pillsbury, is clearly shown by the observations of the Challenger, in ascending and descending the coast of the United States, to

be the edge of a broad band of water enveloping the Bermudas. It is therefore part of the great general easterly and northeasterly movement of the Atlantic waters of the northern hemisphere, a portion of which movement eventually impelled by the anti-trade winds gradually goes to constitute the reflux flow towards Africa, called the Northern Connecting Current.

It has been here said that the body of water which enters the Caribbean Sea as drift currents, produced by the northeast and the southeast trade winds, leaves the residuum to be chiefly supplied by the flow of the polar current under and beside the Gulf Stream issuing from the Straits of Florida. To this is to be added the volume discharged into the Gulf of Mexico and the Caribbean Sea by the various rivers, and we have what makes, allowing for increase and diminution of volume from temperature and evaporation, the sum-total volume to be reckoned for as creating the head of water in the Gulf of Mexico. Taking the temperature of the general sea surface on a line just outside of the Greater and Lesser Antilles to be about 74 F., it is well below that recorded in the Straits of Florida by Lieutenant Pillsbury and other authorities, as often over 80 F., one of them giving a record as high as 86 F. That there should be a considerable rise of temperature between the equatorial waters and those of the Gulf of Mexico, in the Straits of Florida, should not surprise anyone who knows that, according to the investigations of the Challenger, cool water has been found to rise more closely to the surface nearly under the equator than elsewhere in the Atlantic and the Pacific, the temperature of 40° F. reaching to within three hundred fathoms of a surface at nearly 80 F. The equatorial surface generally is surprisingly cool, considering its geographical position, and the equatorial waters are of a lower salinity than are the tropical waters on either side. We

thus see at a glance, not only that they are polar waters which we find immediately below the surface under the equator, but that the moderate temperature and density of the surface are due to their proximity and intermingling with others. Starting, as they do, with greater density than that which, without their translation, would be possessed by waters at the equator, they become, through conduction and convection of heat, of less density than the equatorial surface water, because their pristine density was due to cold, which they finally lose. To suppose that the whole body of water in the Caribbean Sea and the Gulf of Mexico should rise in temperature through all its strata, intermediately to its passage out of the Straits of Florida, would be preposterous; but when we remember that the course taken by these various strata before culminating in a current departing for the high seas represents weeks of time and coincident confinement in a landlocked embayment of the ocean, we ought to perceive that their increase in volume, if not general, must be considerable.

Dr. Carpenter, whose influence was largely instrumental in bringing about the voyage of the *Challenger*, and who freely uses the data collected by it, says, in his article, *The Atlantic*, in the last edition of the *Encyclopædia Britannica*: "It is not a little remarkable that the subsurface stratum of water, having a temperature above 40 F., is thinner under the equator than it is in any other portion of the Atlantic from the Farøe Islands to the Cape of Good Hope. Notwithstanding the rise of the surface-temperature to 76°-80° F., the thermometer descends in the first 300 fathoms more rapidly than anywhere else; as the polar water is met with at a much less depth than in the North Atlantic, and 100 fathoms nearer to the surface, than even in the cooler South Atlantic; whilst the temperature of the bottom is but little above 32°

F." Again, he remarks, in the same article: "The isotherm of 40° F., which, in latitude 22° North, lies at a depth of 700 fathoms, gradually rises as the equator is approached, and it is between the equator and 7° South Latitude, where the temperature rises to nearly 80° F., that cold water is soonest reached—the isotherm of 40° F. rising to within 300 fathoms of the surface, while that of 55° F., which in latitude 22° North lies at nearly 400 fathoms' depth, and in latitude 22° North at about 250 fathoms, actually comes up under the equator within 100 fathoms of the surface."

Both Dr. Carpenter and Professor Lenz, of St. Petersburg, however, the latter of whom, from observation made as early as 1825-1826, in the voyage of the *Kotzebue*, had propounded a theory of such oceanic circulation as that implied by the preceding facts. Dr. Carpenter, in ignorance of having been anticipated, adopted the same views, ascribing the general oceanic movement to a general vertical oceanic circulation sustained merely by the difference of temperature between the polar and the equatorial regions; which theory unwarrantably omits the agency of the rotation of the earth on its axis as one of the primary factors in the phenomena concerned.

It is generally conceded that the Gulf Stream is no longer recognizable as a current beyond 30° West Longitude, but it is not therefore to be supposed that all the waters belonging to it just previously are frittered away and have mysteriously disappeared. As it gradually thins and spreads out in its passage towards the northeastward across the Atlantic, and at the same time gradually diminishes in temperature, it becomes more and more a portion of the grand sweep of surface water from the equator towards the northeast, becoming an integral portion of that movement; and because it is no longer recognizable as a current beyond 30° West Longitude, it does

not follow that its force, added to by the anti-trade wind movement, is expended, but on the contrary, that its force, although imperceptible as a distinct current, is merged in that of the more generally eastwardly movement, and contributes to the general effect. With what vehemence this general movement may act is seen through the report for 1893, of the Fishery Board of Scotland, which, through a scientific exploration of the coast of Norway, the North Sea, and the channels between Scotland and Iceland, in which the Orkney, Shetland and Farøe Islands appear, has discovered that a warm drift current from the Atlantic often sweeps in one place towards the North Sea from the Atlantic. Whether or not it is wholly a drift current, that is, one due to wind, the extraordinary warmth of the northeast Atlantic is thereby affirmed, and the correspondence of the fact with the previous statement is clearly perceptible.

Leaving further discussion of the Gulf Stream at this point, it is proper to conclude with a brief description of the reflux movement of the waters of the Atlantic, corresponding with their westward movement, described in connection with the generation of the Gulf Stream. To speak first of the North Atlantic, the anti-trade winds, and a reflux from the North Equatorial Current, form a current called the Northern Connecting Current, which sweeps around towards the east, in the North Atlantic, from the shores of North America towards those of Africa, enclosing between itself and the North Equatorial Current the well-known waters covered with floating weed, called the Sargasso Sea. Nearing the coast of Africa it passes towards the southeast, and although a portion of it is drafted off into the Guinea Current, another is swept into the North Equatorial Current to renew its ceaseless round. Turning to the Southern Connecting Current we find that a portion of it, known then as the Brazilian Current,

passes down along the coast of Brazil, is then deflected towards the east, in a curve corresponding with reference to the equator to the curve of the Northern Connecting Current, and that it finally passes towards the northeast, off the coast of Africa, where a portion of it is drafted off to form the cool South African Current, while another portion turns into the South Equatorial Current, to continue with reinforcements a round similar to that of the Northern Equatorial Current. The reflux Equatorial Current between the North and South Equatorial Currents flows into the Bight of Biafra, helping with the cool North African Current to compose the Guinea Current.

The influence of the rotation of the earth is well exhibited by these movements. The Brazil Current, in passing southward soon to become a portion of the Southern Connecting Current, is going towards degrees of latitude where the earth's rotation is less swift than it is in the place whence it started. Hence it gradually assumes a curve towards the east, when, finally, it is deflected in quite an eastwardly direction by the pressure on its flank of the Antarctic Current, crowding up along the shore of South America, and additionally receives the impulse of the anti-trade winds of the region towards speeding it on its journey towards the east. Very nearly the same thing takes place in the northern hemisphere with reference to the Northern Connecting Current, the sole difference being that in the latter case the Gulf Stream receives the shock of the Arctic Current on its flank, and thereby shields the North Connecting Current from encroachment on its flank, to which, however, it would be less liable on account of the difference of the lay of the land in North America as compared with its lay in South America.

As both the Northern Connecting Current and the Southern Connecting Current run for the greater part of their courses due

east, and, therefore, the direction of their courses is not, during that portion of their journey, influenced by the rotation of the earth, and as the flow in the opposite direction of the North Equatorial and the South Equatorial Current is perennial, if not strictly constant, and lastly, as there is so great a discharge of water from the Equatorial Currents into the North Atlantic, a constant replenishment of the waters at the sources of the Equatorial Currents is implied with a certainty which involves the certainty that the level of the ocean off the southern coast of Africa is lower than that off the coast of Central America. That the difference between these levels, whatever it may be, is relatively but a small factor in the movement of the Gulf Stream, is self-evident, but as an entering factor it is proper that it should be mentioned. We can justly conceive, however, of a modified Gulf Stream, even if the level of the Caribbean Sea and the Gulf of Mexico were precisely the same with that on the African coast, at the sources of the Equatorial Currents, because it is dynamically part of a movement larger and inclusive of the waters of the whole globe; but we cannot conceive of difference of oceanic level not being an indispensable factor in the movement of the Gulf Stream as it actually exists, and in that larger movement. Whatever agencies, single or collective, are in play must be associated with differences of ocean levels. Assume changes in the present differences of level, and we must recognize that the phenomena of ocean movement would enter upon new phases. Assume that there is no difference of level anywhere, and we should see that the present phenomena would become inexplicable.

It obviously does not follow from appreciation of the valuable results in pelagic history, in the physical hydrography of the sea, and in other departments of knowledge obtained by the Challenger expedition, that one must

agree in opinion with the distinguished chief of its scientific staff in all of his conclusions. Comparing the opinion of Dr. Carpenter with the opinion about to be cited from Sir Charles Wyville Thomson, it will become evident that the former, although accepting the fundamental fact acquired by the Challenger, does not, any more than the present writer, agree with a certain one of the conclusions of Sir Charles Wyville Thomson with reference to the cause of the general vertical oceanic movement. Both Sir Charles Wyville Thomson and Dr. Carpenter ascribe the general vertical oceanic movement to the welling up of the cold waters of the Southern Ocean into the Atlantic and the North Pacific. But, whereas both believe that condition to depend upon a movement sustained merely by the difference in density between the polar and the equatorial waters, Sir Charles Wyville Thomson additionally believes the excess of water received at the equator from the Southern Ocean, as compared with the amount received from north of the equator, to be owing to the excess of precipitation over evaporation in the southern hemisphere, which, of course, involves the excess of evaporation over precipitation in the northern hemisphere. Now, although it is recognized that there is in the southern hemisphere an excess of precipitation over evaporation, the degree, in that particular, of difference between the two hemispheres is not, as Sir Charles Wyville Thomson himself admits, even approximately known, and whatever it may legitimately be assumed to be, it is hardly to be recognized as capable of producing the relatively great general flow from the Southern Ocean to the extent indicated by him. Moreover, the theory is not compatible with the fact that as the equator is approached from either pole the specific gravity of the surface water of the ocean becomes higher and higher, and then lower and lower, until the water reaches

its lowest density in the equatorial region. According to the hypothesis, therefore, of the general vertical oceanic circulation (which is true, but not as depending upon temperature alone), and to the superadded hypothesis that the excess of precipitation in the southern hemisphere causes the thrust of sub-marine cold water into the Atlantic and North Pacific, we should find, what we do *not* find, on account of that very excess of precipitation in the southern hemisphere—the surface waters receding everywhere south of the equator, from the equator towards the southeast, to be of very low specific gravity; which contradicts the statement premised with reference to the specific gravity of the surface waters on each side of the equator, which statement truly represents the facts of the case.

As long as the earth under its present physical conditions shall endure, the movements of the ocean must remain as they now exist, passing through phases of maxima and minima of volume and velocity and oscillation in direction, dependent upon their astronomical and terrestrial relations. The present oceanic forces are, in fact, huge hydraulic engines, worked by nature from the north pole and the south, nor less from the equator and the revolution of the earth. The Gulf Stream, with the analogous Japan Current, is merely one of the two greatest products of that machinery, the flow from its colossal pump, in the direction of its discharging tube and the general circulation of the ocean, partially actuated by the earth's rotation and by the sun-generated winds, being ceaselessly engaged in life-giving and life-aiding agency on the globe.

R. MEADE BACHE.

PHYSIOLOGY IN 1894.

No striking discovery in physiological science was made in the year 1894, and yet a large amount of substantial work has been accomplished both at home and abroad.

Only a few of the more remarkable researches can be here referred to. It has long been known that the swimming or air bladder of sea fishes contains a much larger percentage of oxygen than exists in atmospheric air. The amount may rise as high as 85 per cent. The mode of storage of this large amount of oxygen has always been an interesting question with physiologists, taken in connection with the very small amount of oxygen in sea water. Light has been shed on this problem by the ingenious researches of Professor Bohr, of Copenhagen, who has succeeded in tapping the air bladders of codfish and of drawing off the gas by means of a trocar and an air-tight syringe. He found that the gas contained 52 per cent. of oxygen. In a few hours the bladder was refilled apparently by a process of secretion of gas from the blood in the capillaries on the wall of the bladder, and in one experiment the gas thus secreted contained no less than 80 per cent. of oxygen. Puncture of the air bladder always caused increased secretion of oxygen, but after section of the nerves supplying the organ the evacuated bladder was not refilled with gas. Thus the formation of the gas in the air bladder, which corresponds to the lung of air-breathing animals, is a true secretion of a highly oxygenated gaseous mixture, and the secretion is evidently to some extent under nervous influences. These observations are very interesting when taken in connection with the hydrostatic functions of the swimming bladder. When a deep sea fish descends from near the surface the air bladder is compressed and the body is reduced in size, but to bring the body into equilibrium with the water the fish secretes gas in the air bladder so as to distend it and bring back the body to the original size. This newly-formed gas consists chiefly of oxygen. These experiments by Professor Bohr tend generally to support the theory that the

gaseous exchanges occurring in the lungs of air-breathing animals are not due to purely physical causes, such as different partial pressures of the gases, but to a true process of secretion and excretion.

Very considerable progress has been made in unravelling the intricate mechanism of the brain and spinal cord, and this has been accomplished mainly by the application of the Wallerian method of studying the degenerations that follow section of various strands of nerve fibres or destruction of gray matter. Mott has given experiments that support Munk's original conclusion that the motor area on the cortex of the cerebral hemispheres is also connected with sensations of touch and pressure, and is not solely for the emission of motor impulses, or, in other words, that the mechanisms for sensation and touch and for motor impulses are closely related in the brain. Bayliss, Bradford, Boyce, Sherrington, Langley and Anderson in this country have also investigated the convexions of the various spinal nerves with the great plexuses or networks from which issue the main nerves of the limbs, and thus physiologists are slowly accumulating knowledge that will by-and-by be of great value to the physician. It will be possible to correlate sensations in various areas in the skin and various muscular movements with certain nerve roots and with certain portions of the spinal cord. In other words, a new physiological anatomy will be established by experiment and facts will be discovered that could never be laid bare by the scalpel. The most notable advance, however, in nervous physiology has been made by Gustav Mann, of Edinburgh, who, following the lead of an American observer, has demonstrated material changes following the stimulation of nerve cells in the sympathetic ganglia, in the cord, and even in the brain itself. Under stimulation the cells appear to swell and to become clearer owing to a peculiar

matter termed chromatin being used up. In this way even long continued stimulation of the retina by light has been found to cause changes, visible to the microscope and depicted by photography, in the nerve cells of the part of the brain which is the seat of the consciousness of vision.

Numerous researches have been made on the functions of the liver, kidney, pancreas and spleen, all going to show that these organs are not related only to one or even two individual functions, but that each organ is the seat of complex metabolisms, or changes of which the obvious secretion is only the outward expression. Thus, the liver not merely secretes bile and forms glycogen, but it also has important anti-toxic powers by which poisonous matters, formed possibly in the intestines and carried thence to the liver, have their effects counteracted. The organ is also concerned in the decomposition of proteids and even in the transformation of fats. In like manner the kidneys and the pancreas have intestinal functions, the nature of which is still obscure to physiologists. Lastly, the selective actions of epithelial cells are receiving greater attention, and it is found that these play an important part in many vital phenomena. By the activities of these cells physical operations, such as the passage of certain substances through membranes, are so modified as to make it impossible, in the present state of science, to regard them as purely physical. A molecular physiology of the future may demonstrate that they are truly physical, but at present the vitality of the tissues involved is an unexplained factor in the process.

In the field of physiological acoustics the phonograph promises to be an instrument valuable in research. Soon after its invention the tinfoil phonograph was used successfully by the late Professor Fleeming Jenkin and Professor Ewing (now of Cambridge) in the investigation of vowel sounds,

but the instrument was little known to physiologists. Since 1890, however, it has in its improved form, with a wax cylinder, engaged the attention of Professor Hermann, of Königsberg, and more recently of Dr. Boeke, of Alkmaar, and of Professor M'Kendrick, of Glasgow. By an ingenious method of photographically recording the vibrations of the marker that runs over the impressions produced by sounds on the wax cylinder of the phonograph, and which, by acting on a thin glass plate, reproduces the sounds, Hermann has obtained the curves corresponding to the tones of the vowels, and he has shown that the vowels are true musical tones, each having its own proper pitch, and not, as Von Helmholtz supposed, the pitch of a harmonic tone corresponding to the shape of the oral cavity when the vowel sound is uttered. When one considers that the phonograph can faithfully reproduce human speech, the sounds of a musical instrument, of a quartette or chorus of human voices, or the sounds of an orchestra, and that all these sounds and tones are imprinted on the wax cylinder of the phonograph in the form of a more or less complicated wave, it is manifestly of great importance to determine the wave form for any particular sound. If this could be done, not only would it be of great scientific interest to submit the curve to harmonic analysis (as was done by Jenkin and Ewing), and thus determine the component waves, but it might be possible to cut the curves on the margin of a wheel, or other appropriate device, and thus construct a speaking or singing machine. Speech and song and orchestral effects might be multiplied mechanically. The grooves on the wax cylinder vary in depth from the 1-1000th to the 1-2000th of an inch, and, thus, as the curve is in the bottom of the groove, it is a difficult matter to trace its form. Boeke has measured the transverse diameters of the grooves at different points, and from

these measurements he has calculated the depths, and thus he has endeavoured, as it were, to construct the curve. M'Kendrick has taken direct photographs of the marks on the wax cylinder, and has thus been able to demonstrate vibrations (or 'dabs' on the wax cylinder traveling with great velocity) made at the rate of 1,500 to 1,800 per second. He has also shown that there is a definite form of these markings for pure tones, for the simpler chords, and for very complex tones, such as those of the organ, piano, or a quartette or chorus of human voices. By adapting large resonators to the phonograph, M'Kendrick has also made it possible to so increase the volume of tone as to make it audible even in a hall of considerable size. Edison and others have frequently used large resonators, but M'Kendrick has gone further in this direction. Recognizing, however, that resonance cannot increase the volume of tone beyond a certain limit, he has made use, with much success, of Mr. Alfred Graham's ingenious loud-speaking telephone, along with a transmitter of variable resistance, as supplied by Messrs. Muirhead and Co., of Westminster. In this way the tones of the phonograph are much amplified in volume and improved in quality. To physiologists the interest of these researches lies in the mode of action of the vibrating plate of the phonograph. This acts like the drumhead of the ear. Consequently the better the modes of movement of such a plate are understood the better can we explain the mechanism of the drumhead of the ear—a drumhead, however, infinitely more sensitive than the phonograph plate.—*London Times*.

CURRENT NOTES ON PHYSIOGRAPHY (XIII).

THE CATOCTIN BELT OF MARYLAND AND VIRGINIA.

THE Blue ridge, dwindling from the Carolina highlands, extends a few miles north of the Potomac at Harper's Ferry, there

overlapping the southern extension of South Mountain from Pennsylvania. Five or ten miles to the east, on both sides of the Potomac, Catoctin Mountain repeats in many respects the structural and geographical features of Blue Ridge and South Mountain. The geographical features of this region are described and explained in a valuable essay on the 'Geology of the Catoctin Belt' by Arthur Keith (14th Ann. Rep., U. S. G. S., 1895, 293-395). The Tertiary 'baselevel' is the most extended surface of the region. Catoctin and various other residuals of hard rocks rise above it, and numerous valleys are entrenched beneath it. Three stages of post-Tertiary denudation (two Pleistocene and one recent) are indicated by the 'base-levels' observable in the valleys. The even summits of Catoctin and the other residuals above the Tertiary plain indicate two stages of pre-Tertiary denudation; but these older 'baselevels' are now so greatly consumed that they are referred only in a general way to Cretaceous time. Judging by the volume of denuded rocks, the ratios of Tertiary, early Pleistocene, later Pleistocene and recent time are as 134, 1, $\frac{1}{2}$, and a 'small fraction.' The small consideration of marine erosion marks the essay as distinctly belonging to the American school.

The residual hills of this region are so characteristically developed that in 1891 McGee suggested the use of Catoctin as a generic name for such topographic forms (5th session, Internat. Geol. Congress, 249), in the same way that I have used *Monadnock* in New England (Nat. Geogr. Mag., V., 1893, 70). Recent practical experience has shown me that it is convenient to use both these terms; *Monadnock* to apply to residual eminences that surmount peneplains of Cretaceous denudation, such as are common in the highlands of New England and Carolina, and *Catoctin* to apply to the residuals that surmount Tertiary peneplains, such as are common over the inner

piedmont belt of Virginia. Whether so special a terminology will commend itself to general usage remains to be seen. It may be noted that Keith employs 'base-level' in a topographic sense to which strong objection may be urged. (See SCIENCE, February 15, 1895, 175.)

RECENT TOPOGRAPHICAL MAPS.

RECENT topographical sheets issued by the United States Geological Survey represent a number of areas of particular interest. Those for New York, the joint product of State and National funds, are especially welcome. The Oriskany, Oneida, Chittenango and Syracuse sheets portray the northern margin of the Alleghany plateau where it descends to the lowland of central New York; the eastern sheet includes Rome, where the Mohawk enters the broad valley that, according to Gilbert, once served as the outlet of the expanded Lake Ontario. The Syracuse sheet includes the beginning of a remarkable area of drumloidal drift hills, and also shows some of those curious abandoned channels near the margin of the plateau that seem to have been cut by temporary streams, constrained into peculiar courses by the melting ice sheet. Elmira and Rochester are included on other sheets of interest in connection with recent papers of Fairchild (see SCIENCE II., p. 11; Amer. Geologist, xvi., 39-51). The Ithaca sheet illustrates the general dissection of the plateau and the morainic obstruction of some of its valleys, referred to by Chamberlin (3d Ann. Rept. U. S. G. S., 357). The Catskill and Rhinebeck sheets make the series for the Hudson almost complete from New York City to Albany. A large part of the Ausable basin in the Adirondacks is included in the Mt. Marcy, Ausable and Plattsburg sheets, offering interesting problems about lakes and gorges for attentive study. The Pulaski sheet at the eastern end of Lake Ontario exhibits the simplifi-

cation of an originally irregular shore line by cutting off headlands and throwing bars across bays.

In other States, the Bath (Maine) sheet is a remarkably effective illustration of a ragged coast line; it includes the northward deflection—presumably by drift barriers—of the Androscoggin at Brunswick to the expansion of the Kennebec in Merry-meeting bay. Wood River, Grand Island, Minden and Kearny sheets, Nebraska, show how the overburdened Platte sprawls across the Plains in its many channels. The shore line on the Seattle (Wash.) sheet has a number of low cusped points, apparently small-scale examples of the action of eddying currents. For the most of us who cannot see the country itself, these maps are highly illuminating and suggestive.

THE DELAWARE WATER GAP.

THE plunging Medina sandstones that form Kittatinny mountain, the wall on the northern side of the Great Appalachian valley in Pennsylvania, are trenched across by a number of streams, all flowing from the region of the inner Alleghany ridges southeast towards the sea. It may be plausibly suggested that the ancestors of these streams originally ran to the northwest, as the New-Kanawha of Virginia still does; but that in Pennsylvania the drainage was afterwards turned to the present direction of discharge in some manner not now well defined but probably dependent on moderate deformation and the associated shifting of divides. The date of this change is not settled, but it is supposed to have been before the post-Cretaceous elevation of the region. This would imply that the Tertiary excavation of the broad longitudinal and the narrow transverse valleys or water gaps was accomplished by rivers running as a whole in their present courses.

A recent article by Emma Walters (Does the Delaware water gap consist of two

river gorges? Proc. Acad. Nat. Sci., Phila., March, 1895) takes another view in suggesting that the most noted of the water gaps is the work of a river that ran northward for most of the time while it was cutting down the gap, and that it assumed its present direction in comparatively recent time. The local and immediate evidence quoted to indicate a northward flow is a pool, fifty to seventy feet deep, on the northern side of the hard sandstone sill of the gap; but the excavation of such a pool seems to be within the power of a strong river flowing in a narrow, curved channel. Collateral evidence of northward flow is found in the favorable interpretation of a number of indecisive observations made by various geologists, but the value of this kind of evidence is very uncertain.

W. M. DAVIS.

HARVARD UNIVERSITY.

PSYCHOLOGICAL NOTES.

THE SENSE OF EQUILIBRIUM.

DR. A. CRUM BROWN, in a lecture on 'The Relation between the Movements of the Eyes and the Movements of the Head' (printed in *The Lancet*, May 25th, and in *Nature*, June 20th), reviews the evidence that has led to the assumption that the semi-circular canals (together with the utricle and sacule) of the inner ear are sense-organs, giving us our information concerning position and equilibrium of the body. This view is now universally accepted, although the evidence is only circumstantial and not altogether conclusive to the present writer. There is no doubt but that injuries to the semi-circular canals cause corresponding disturbances in equilibrium, but dizziness and sickness are also caused by visual sensations. We may become dizzy from watching a waterfall, and when whirled about grow dizzy much more quickly when the eyes are open than when they are closed. It would seem that

our instinctive knowledge of equilibrium and of a motion of the body as a whole depends on very complex sensory impressions. One of these is very probably the pressure due to inertia of the perilymph and endolymph of the semi-circular canals, but it is quite possible that the inertia and weight of the soft parts of the head and body are more important factors. Rotation of the body would tend to cause congestion of the brain cortex by centrifugal action, and the resulting dizziness would be analogous to that accompanying intoxication or fever. The position of the body as a whole affects not only the circulation of the blood, but also the pressure of brain, viscera, etc., and the alterations in the direction in which gravity acts would cause important changes in muscular tensions. Motion of the body as a whole would cause pressure of the soft parts of the body on those more hard, and skin sensations (due to inertia of the body as a whole) would occur at points where the body touches other things. Sensations from the soles of the feet are of great delicacy, being part of the reflex mechanism which enables us to stand upright.

CONSCIOUSNESS AND THE ORIGIN OF SPECIES.

PROFESSOR COPE contributes to the July number of *The Monist* an article in which he formulates with great clearness the *Present Problems of Organic Evolution*. He sums up the positions of the Neo-Lamarckians and Neo-Darwinians in the accompanying table. It is of special interest to the present writer owing to the definition of the place of consciousness in the two theories, thus calling attention to the relations of modern psychological research and evolutionary theories. The general result of psychological investigation seems to increase the difficulties and decrease the need of assuming consciousness in causal interaction with the physical world, whereas the biologist finding physical causes insufficient ad-

1. Variations appear in definite directions.

2. Variations are caused by the interaction of the organic being and its environment.

3. Acquired variations may be inherited.

4. Variations survive directly as they are adapted to changing environments (natural selection).

5. Movements of the organism are caused or directed by sensation and other conscious states.

6. Habitual movements are derived from conscious experience.

7. The rational mind is developed by experience, through memory and classification.

1. Variations are promiscuous or multifarious.

2. Variations are 'congenital,' or are caused by mingling of male and female germ-plasmas.

3. Acquired variations cannot be inherited.

4. Variations survive directly as they are adapted to changing environments (natural selection).

5. Movements of organism are not caused by sensation or conscious states, but are a survival through natural selection from multifarious movements.

6. Habitual movements are produced by natural selection.

7. The rational mind is developed through natural selection from multifarious mental activities.

duces consciousness as a *vera causa* in the origin of species. J. McK. C.

SCIENTIFIC NOTES AND NEWS.

THE PARALLAX OF ETA CASSIOPEE DEDUCED FROM THE RUTHERFURD PHOTOGRAPHIC MEASURES.*

THE new value of the parallax of this well-known binary star is not without considerable interest in view of the fact that it depends upon several pairs of comparison stars, thus eliminating largely, though, of course, not entirely, the disadvantages arising from the unknown parallaxes of the stars of comparison; whereas, in the two previous investigations by O. Struve and by Schweizer respectively, only one star has been used, and that probably the same star in both investigations, and one in such

*Based on Contributions from the Observatory of Columbia College, New York. No. 6. By Herman S. Davis.

a position relative to the proper motion of γ Cassiopeïæ as to be most largely affected by any error in the assumed value thereof. Moreover, the value of $+.''154$ obtained by Struve has received a much larger share of credence than the circumstances connected with obtaining it would warrant—Struve himself saying of it: “la plus grande difficulté se rencontra dans les observations de γ Cassiopeæ à cause d’une distance de 5' pour l’étoile de comparaison, distance qui atteint déjà les limites extrêmes de la bonne visibilité dans le champ de notre lunette.” This is incidentally referred to by the author (page 305), where reference is given also to a remark, not very dissimilar, made by Socoloff relative to Schweizer’s observations. Thus it may be seen that the want of near-by stars renders the determination of the parallax of this star very difficult, especially by micrometric observations; and though this difficulty is considerably lessened by the larger field of the Rutherford photographic plates, yet even now stars farther from the centre of the plate than would have been desirable under more favorable conditions had to be chosen. This seems not to have vitiated the result, for the values of parallax obtained from the separate pairs are, with one exception, accordant within the limits of their probable errors. This exception may be due to a parallax or, not possibly, to a proper motion of one or other of the comparison stars. This uncertainty, and the fact that the pairs g, h and i, j were, as the writer believes, included more to throw light upon the presence or absence of film-distortion than upon the parallax, has influenced Dr. Davis to prefer the first of the two values he publishes, namely:

$$\pi = + 0.''443 \pm 0.''038 \text{ from three pairs,}$$

the other value being

$$= + 0.''465 \pm 0.''034 \text{ from six pairs.}$$

Using the first value, therefore, and the

elements of this binary system as given by Dr. See in *Ast. Journ.* 343, it is interesting to note that the distance of this star from the earth is about seven and one-third ‘light years’ and that the combined mass of Eta and its companion is only .175 as great as the mass of our sun, and that the relative orbit in which these two stars revolve about this common centre of gravity is very nearly equal to that in which the planet *Neptune* circles about the sun.

THE MARINE BIOLOGICAL LABORATORY.

IN the prefatory note to the biological lectures delivered at Woods Holl, 1894, Professor Whitman writes as follows: “When the first volume of these lectures was offered, in 1890, their continuance as an annual publication was thought of only as a possibility; it was not promised, nor, indeed, suggested. The usefulness of such lectures had only been tested by a single summer’s experience; and, although it was certain that they served a good purpose in the work of the laboratory, the advisability of publishing them was doubtful. While the reception accorded to the two volumes already issued indicates that it would not now be presumptuous to announce the hope of continuing them, it would be rash to promise this in the present state of uncertainty regarding the future of the laboratory. The laboratory is an experiment to test the extent of our need and the possibility of securing general coöperation. It has furnished a demonstration in both these respects; but it remains to be seen whether this will suffice to bring to it the necessary foundation of a large endowment. Special thanks are due to those who, in reviewing the ‘Biological Lectures,’ have called attention to the nature and purpose of this experiment and to the high importance of the end proposed. The project appeals, not for government support, but to private munificence, and every authoritative con-

firmation of its merits adds strength to our effort." There is perhaps no institution in America accomplishing more for the advancement of science with a limited expenditure and none more deserving of a larger endowment.

THE POPULATION OF FRANCE.

It is well known that the lack of increase of the population of France causes serious anxiety to its statesman. M. Chervin has recently presented some statistics before the *Société d'Anthropologie* which we quote from *The Lancet*. The table gives in the first column the number of legitimate living children born per thousand women aged between fifteen and fifty years. The corresponding number of illegitimate children is given in the second column.

| | | |
|--------------------|----------|------|
| German Empire..... | 270..... | 26.5 |
| Scotland..... | 269..... | 19.9 |
| Belgium..... | 265..... | 19.8 |
| Italy..... | 251..... | 24.6 |
| England..... | 250..... | 12.1 |
| Austria..... | 250..... | 44.4 |
| Sweden..... | 240..... | (?) |
| Ireland..... | 240..... | 4.1 |
| Switzerland..... | 236..... | 10.2 |
| France..... | 163..... | 16.7 |

M. Rochard has recently attributed the low birth rate in France to alcoholism. The annual consumption of alcohol is 6.45 centiliters per person per annum, and there is in Paris one wine shop for every three houses. The birth rate is, however, undoubtedly due largely to French social customs—to prodigality in Paris and thrift in the provinces.

KARL LUDWIG'S LIBRARY.

THE physiological library of the late Professor Ludwig is offered for sale by Th. Stauffler, 26 Universitäts Str., Leipzig, who has in preparation a catalogue which he will send on application. It would be a great advantage if some American institution could purchase the library as a whole.

The library includes 10,000 memoirs, pamphlets and dissertations on anatomy, physiology and related subjects, which are offered for 6,000 marks. In addition, several valuable sets of journals are for sale. As it is becoming continually more difficult to secure sets of these journals, we give the following details:

Annalen der Chemie und Pharmacie (1832-1893) 2,500 M. Annalen der Physik und Chemie (1824-1892) 2,650 M. Zoölogischer Anzeiger (1878-1893) 160 M. Archiv für Mikroskopische Anatomie (1865-1895) 1,300 M. Archiv für Physiologie (1877-1894) 420 M. Bericht über die Fortschritte der Anatomie und Physiologie (1856-1871) 50 M. Berichte der Deutschen Chemischen Gesellschaft (1868-1893) 600 M. Centralblatt für die Medicinischen Wissenschaften (1-33) 200 M. Die Fortschritte der Physik (1845-1888) 450 M. Medicinische Jahrbücher (1871-1888) 150 M. Jahresbericht über die Fortschritte der Anatomie und Physiologie (1873-1893) 330 M. Jahresbericht über die Fortschritte der Chemie Physik u. Mineralogie (1847-1893) 775 M. Jahres Bericht über die Fortschritte der Thierchemie (1871-1893) 300 M. Göttinger Nachrichten (1862-1894) 95 M. Proceedings of the Royal Society of London (1866-1895) 300 M. Philosophische Studien (1883-1895) 120 M. Philosophical Transactions of the Royal Society of London (1875-1894) 600 M. Zeitschrift für Analytische Chemie (1862-1883) 270 M.

THE AMERICAN PHILOLOGICAL ASSOCIATION.

THE twenty-seventh meeting of the American Philological Association was held at Western Reserve University on July 12th, under the presidency of Professor John Henry Wright, of Harvard University, who delivered an address on the 'Function of the Imagination in Classical Philology.' More than twenty papers were

presented before the meeting, among which may be mentioned as of general scientific interest an address by Professor George Hempl, of the University of Michigan, who exhibited some 'American speech maps' showing the geographical distribution of various dialectal peculiarities, and a description by Professor Schmidt-Wartenberg, of Chicago, of Rowsselot's phonetical apparatus which, it is hoped, will facilitate the study of speech from a physical standpoint. The report of the committee appointed at the Philadelphia meeting last winter to take steps toward some practical outcome of the following resolution: "That in the opinion of the American Philological Association, in any programme designed to prepare students for the classical course, not less than three years of instruction in Greek should be required," was presented. The action of the committee in drawing up and widely distributing an address on this subject was approved by the Association.

The next meeting will be held at Providence, R. I., on July 7, 1896.

GENERAL.

PROFESSOR W. RAMSAY read a paper before the Chemical Society of London on June 20th, in which he stated that there is no doubt but that argon and helium contain as a common ingredient a gas not hitherto identified, two lines in the spectra in the newly discovered elements being identical. The atomic weight of the new gas would be about 10. In the issue of *Nature* for July 4th Professor Ramsay states that he has demonstrated the presence of both argon and helium in a meteorite from Augusta County, Virginia. The characteristic spectrum of argon is almost completely masked by the presence of a few parts per cent. of nitrogen or of hydrogen, and that of helium is similarly affected, though to a less degree. In so far as the lines of the argon spectrum

have not been identified in the spectra of stars it is probably because they are masked by the spectra of hydrogen and carbon.

In the *American Naturalist* for July an account is given of the Hopkins Seaside Laboratory. The laboratory is located at Pacific Grove, a seaside resort on the southern shore of Monterey Bay, about four hours distant by train from San Francisco. The coast line at this point offers every variety of rocky and sandy shores, and the variety and abundance of marine life is exceptionally great. The original building contains three general laboratories, a store room and seven private rooms for investigators; the new building contains a general lecture and library room, a general laboratory, ten private rooms for investigators and a dark room for photographic work. The basement is designed for large aquaria. The buildings are supplied with running water; both salt and fresh. The session (which is the fourth) began on June 17th, and the regular course of instruction continues till July 17th, but investigators and students not requiring instruction may continue their work during the summer.

ACCORDING to the *Genie Civile*, quoted in the *Scientific American*, the Geographical Society of Toulouse has for some years been studying the possibility of the application of the decimal system to the measurement of time and angles. As a result of these studies, a scheme has been devised which is to be presented to the coming Geographical Congress in London. It is proposed to divide the circle into 100 'cirs' (abbreviation of *circulus*), with decimal subdivisions of 'decirs,' 'centicirs,' 'millicirs' and 'dimicirs.' The letter X (initial letter of Greek *κυκλος*) is chosen to represent the cir, and an angle of 7 cirs, 77 centicirs and 51 dimicirs would, therefore, be written 7^x7751. For the decimal measurement of time, the day, from midnight to midnight, is di-

vided into 10 decimal hours, each hour into 10 'cés' (abbreviation of centijour), each cé into 10 'décicés' or decimal minutes, and the latter into 'centicés,' 'millicés,' 'dimicés,' etc.

M. M. DELEBECQUE and Le Royers report to the Paris Academy that they have found that the quantity of air dissolved in water in the Lake of Geneva is independent of the pressure of the water, being slightly greater (owing to the decrease of temperature) at the bottom than at the surface.

THE *Société d'encouragement pour l'industrie nationale* held its annual meeting for the distribution of the awards of the Society on June 28th. A large number of prizes and medals were awarded, among which may be mentioned the large prize of 12,000 francs awarded every six years for the invention most useful to French industry, which was given to M. G. Lippmann for the invention of color photography. The large gold medal awarded every three years for the work that has exercised the greatest influence on French industry during the six preceding years was awarded to the 'Comité de l'Afrique française' for their publications. Among the prizes is one awarded to the artisan who has worked for the greatest number of years in a chemical factory.

At the meeting of the Astronomical and Physical Society of Toronto, held July 9th, Mr. Thomas Lindsay read the introductory chapter to a series of papers which it is his intention to present as an historical sketch of the Greenwich Nautical Almanac, which was claimed to be next to the Bible the greatest production of the printing press.

A STATE civil service examination will be held in Albany on August 6th for candidates for the position of fish culturist in the State Fish, Game and Forest Commission. The salary is \$3,000.

THE British Medical Journal states that the following names of distinguished scien-

tific and medical men will be given to different Paris streets: Trousseau, Charcot, David Ulysse Trélat, Milne Edwards, Jean Baptiste Dumas.

THE Pan-American Congress of Religion and Education met at Toronto from the 18th to the 25th of July.

A SPECIMEN of the egg of the great auk was recently sold in London for £173-5-0. This specimen, which is perfect, was taken in Iceland some 60 or 70 years ago and comes from the collection of Baron d'Hamoville.

HENRY HOLT & Co. announce for publication an authorized translation of Paulsen's 'Introduction to Philosophy,' by Prof. Frank Thilly, of the University of Missouri, with a preface by Prof. William James, of Harvard University.

At the meeting of the Paris Academy of Sciences, on June 4th, Prof. Fuchs was elected correspondent in geometry in the place of Weierstrass; Dr. Nansen was elected correspondent in the section of geography, succeeding Nordenskiöld, and Dr. Lavarán correspondent of the section of medicine and surgery in the place of Hannover.

THE *Botanical Gazette* announces the death of Julian Deby, known for his study of diatoms.

UNIVERSITY AND EDUCATIONAL NEWS.

THE University of Pennsylvania has issued an appeal asking for an endowment fund of \$5,000,000 to meet the immediate requirements of the University. Mr. Thomas McKean has given without restrictions a sum of \$50,000 in addition to the \$50,000 given a few months ago. A contribution of \$10,000 has also been received from Mr. Richard F. Loper to name a house in the new dormitory. It is stated that this is the thirteenth contribution of a similar kind that has been received.

It is stated that the University of Cincinnati has received a gift of \$45,000 from Mr. Henry Hanna, to be used in the erection of a wing in the new University building.

THE Belgium ambassador in Berlin has called the attention of the German government to the fact that imitations of the stamp of the University of Ghent have been counterfeited with a view to selling diplomas of the University, and the Berlin Foreign Office gives warning of the existence of these documents.

PROFESSOR WILLIAM J. HUSSEY, of Illinois, has been appointed to succeed Professor Bernard as astronomer of Lick Observatory.

DR. L. A. BAUER, formerly of the U. S. Coast and Geodetic Survey, is lecturing this year on mathematical physics and on geophysics at the University of Chicago.

J. ALLEN GILBERT (Ph. D., Yale) has been made assistant professor of psychology at the University of Iowa.

PRINCIPAL PETERSON has been presented with a gift of silver plate on the occasion of his leaving the University of Dundee to become president of McGill College, Montreal.

It is stated that J. H. Tyrrell, of the Geological Department of Canada, will be elected professor of geology and mineralogy in the University of Toronto, succeeding Professor Chapman, who has just resigned.

It is stated that Professor Hering, of Prague, has been offered the chair of physiology, vacant by the death of Professor Karl Ludwig.

DR. ELEXANDER ROLOSSOW has been appointed professor of histology and embryology in the University of Warsaw in the place of Dr. H. Hoyer, who has resigned.

DR. SOMMER, professor of anatomy in Greifswald University, has tendered his resignation, to take effect on September 1st.

WE learn from the *Naturwissenschaftliche Rundschau* that the geologists Dr. Robert Scheibe and Dr. Fritz Kötter have been appointed professors in the Bergakademie, of Berlin. Dr. Rex and Dr. Steinbach have been appointed to assistant professorships of anatomy and physiology, respectively, in the University of Prague.

DR. TH. CURTIUS has declined a call to the professorship of chemistry in the University of Tübingen, vacant through the death of Lothar von Meyer.

PROFESSOR H. WILD, director of the Central Observatory, University of St. Petersburg, has resigned his position on account of ill health.

CORRESPONDENCE.

BALM FOR WOUNDED AUTHORS AND PROOF-READERS.

THE recent receipt of Dr. Wortman's memoir 'On the Osteology of *Agriochærus*,' like its several predecessors published within a year or so, has recalled a remarkable lapse of memory occurring to two of the most eminent and sagacious naturalists of all time. The case is of psychological significance, and I have thought it might amuse as well as interest readers of SCIENCE.

Prof. Huxley, in his excellent 'Introduction to the Classification of Animals' (published in 1869), in his first chapter, 'On Classification in General,' concluded a consideration of Cuvier's law of the correlation of structure with the following paragraphs:

"Cuvier, the more servile of whose imitators are fond of citing his mistaken doctrines as to the nature of the methods of palæontology against the conclusions of logic and of common sense, has put this so strongly that I cannot refrain from quoting his words.*

"But I doubt if any one would have divined, if untaught by observation, that all ruminants have the foot cleft, and that they alone have it. I doubt if any one would have divined that there are frontal horns only in this class; that those among them

* Ossemens fossiles, ed. 4^{me}, tome, 1^r, p. 184.

which have sharp canines for the most part lack horns.

"However, since these relations are constant, they must have some sufficient cause; but since we are ignorant of it, we must make good the defect of the theory by means of observation; it enables us to establish empirical laws, which become almost as certain as rational laws, when they rest on sufficiently repeated observations; so that now, whose sees merely the print of a cleft foot may conclude that the animal which left this impression ruminated, and this conclusion is as certain as any other in physics or morals. This footprint alone, then, yields to him who observes it, the form of the teeth, the form of the jaws, the form of the vertebrae, the form of all the bones of the legs, of the thighs, of the shoulders, and of the pelvis of the animal which has passed by; it is a surer mark than all those of Zadig!"

The first perusal of these remarks would occasion surprise to some and immediately induce a second, more careful reading to ascertain whether they had not been misunderstood. Men of much inferior capacity than Cuvier or Huxley, like myself, must have at once recalled living exceptions to the positive statements as to the coördination of the 'foot cleft' with the other characters specified. One of the most common of domesticated animals—the hog—would come up before the 'mind's eye,' if not the actual eye at the moment, to refute any such correlation as was claimed. Nevertheless, notwithstanding the fierce controversial literature centered on Huxley, I have never seen an allusion to the lapse. And yet every one will admit that the hog has the 'foot cleft' as much as any ruminant, but the 'form of the teeth,' and the form of some vertebrae are quite different from those of the ruminants, and of course the multiple stomach and adaptation for rumination do not exist in the hog. That any one mammalogist should make such a slip is not very surprising, but that a second equally learned should follow in his steps is a singular psychological curiosity. To make the case clearer to those unacquainted with mammals, I may add that *because the feet are cleft in the same manner* in the hogs as in the

ruminants, both groups have long been associated in the same order under the name of Paridigitates or Artiodactyles, contrasting with another (comprising the tapirs, rhinocerotids and horses) called Imparidigitates or Perissodactyles.

I need scarcely add that the law of correlation applied by Cuvier to the structures of ruminants entirely fails in the case of many extinct mammals discovered, since Cuvier's days. Zadig would have been completely nonplussed if he could have seen the imprint of an Agriochærid, a Unitatheriid or a Menodontid.

Another instance of failure of observation or memory nearly equally remarkable was published several years ago in various daily papers, and the following extract from one of them is given :

"FOUR INTELLIGENT PROOF-READERS.

"The question whether a proof-reader must have knowledge of the contents of any article that passes through his hands having been discussed in a German paper, the *Frankfurter Zeitung*, brings the following amusing contribution from Prof. Karl Vogt, the celebrated scientist, in illustration of this problem.

"When Edward Desor and myself were working with Agassiz at Neuenburg [Neuchâtel] my friend Desor was charged with describing certain fossil fish after the latter's notes. Desor used to dictate these descriptions to a young man who pretended to know all about it, while Desor counselled him to consider himself merely an unconscious tool. To sound the knowledge of his clerk, my colleague one day, under my convivance, dictated to his secretary the most absurd nonsense by interlacing the description of some fossil fish with the particular statement. 'This remarkable specimen differs from all others in the abnormal fact of having its head in the same spot where the others' tails are found.' The clerk took everything down as it came from the lips of my collaborator without rebelling. Desor, accidentally being called away, forgot his trick, and the manuscript went to the printing office. The proof was read by Dr. G., who had expressly been appointed to the post by Agassiz, and besides entrusted with the compilation of his 'Nomenclator.' Desor and myself read the second proofs; so did Agassiz, who placed his imprimatur upon them, but none of us four took notice of the nonsense it contained. The whole was printed, and only then, when the series was about to be sent

to the subscribers, my friend Desor remembered the trick he had played on his amanuensis. A special card had to be inserted in place of the objectionable passage. The conclusion may easily be drawn—four proof-readers had read the article without consciously taking knowledge of its contents.’

I suppose that every author who has published much must have felt disgusted at finding some glaring error in a paper of which he had read the proofs and yet failed to detect. Such failure is not very surprising, however, as attention is concentrated on form and typography. But it is surprising that four men of such learning as Agassiz, Desor, '(G.)' and Vogt should all have passed unnoticed the evident absurdity quoted by Prof. Vogt. Perhaps the fact they did so may reconcile others to their blunders. I offer this balm (which has been of service to me!) for those interested.

Yours truly,

THEO. GILL.

WASHINGTON, July 11, 1895.

THE GENERIC NAME *ANISONYX* PRE-
OCCUPIED.

IN the first number of the new series of *SCIENCE* (Vol. I., No. 1, Jan. 4, 1895, 18-19) I called attention to the fact that the generic name *Anisonyx* of Rafinesque (1817) antedates *Spermophilus* of Cuvier by eight years, and seemed to be the earliest available name for the ground squirrels. Fortunately, however, *Anisonyx* is preoccupied. In a rare work by Latreille entitled *Genera Crustaceorum et Insectorum*, and published in 1807, the name *Anisonyx* was proposed for a genus of Coleoptera, thus antedating Rafinesque's use of it by ten years.

C. HART MERRIAM.

CORRECTION.

IN the review of the Twenty-third Annual Report of the Geological Survey of Minnesota, etc., in *SCIENCE* of July 5, p. 23, first column, near top, the Keewatin rocks are referred to the Upper Algonkian,

of the U. S. Geological Survey, whereas they should have been referred to the *Lower* division.

EUGENE A. SMITH.

SCIENTIFIC LITERATURE.

Les aurores polaires. By ALFRED ANGOT. Paris, Felix Alcan. 1895. Bibliothèque Scientifique Internationale. 230 pages with an appendix catalogue and many illustrations.

The well known meteorologist of the Bureau Central Météorologique takes occasion to say, in the introductory chapter of this book, that the lack of any volume in French dealing exclusively with the aurora, since the time of Bravais, 1839, was a prime consideration in the issue of this volume. Information concerning the aurora had to be sought in stray notes, miscellanies, etc. Our author attempted a partial remedy by contributing in 1882 to 'La lumière électrique' a series of ten papers giving a general view of our knowledge of the aurora; and the present volume consists practically of these ten papers expanded and brought up to date. Appearing in 1895, some mention of Lemstrom's 'l'Aurore boreale' (1886) and Paulsen's 'Contribution a notre connaissance de l'aurore' (1889) might have appropriately been made; and the omission is the more noticeable in that the former work is referred to in the chapter on the physical character of the aurora.

The illustrations are chiefly reproductions of sketches made by French observers in high latitudes; but it must be confessed that sketches made in 1839, 1870 and 1879 seem a trifle antiquated. No mention is made of the fact that the aurora has been photographed. Tromholt made an attempt as early as 1885 to do this. Very fair photographs considering the conditions were obtained in 1892 by Dr. Martin Brendel and Herr O. Baschin at Bossekop.

The form and appearance of auroras, their physical character, frequency, relation to

the weather, etc., are treated pleasantly in various chapters; but the chief results of the International Circum-polar Stations are hardly alluded to. In the chapter on theories respecting the origin of the aurora no mention can be found of Lockyer's ingenious meteoric theory. The data given respecting the height of the aurora are likewise far from complete; and in the table on page 71, giving wave-lengths of lines found in the auroral spectrum, only 14 lines are given, which doubtless was the full number in 1882, but which now contrasts strangely with Gyllenskiöld's detailed description of 32 lines.

Lemstrom's experiments upon the artificial reproduction of the aurora do not seem to our author to be all that has been claimed for them; and, after noticing Tromholt's unsuccessful attempt with similar apparatus, he gives the experience of M. Vaussenat at the Pic du Midi, who, at an elevation of 2,877 metres, with a network of wire covering an area of 640 square metres, obtained nothing in the way of an artificial aurora. So, like many another explanation of the aurora, this may be laid away for the present as unproven. The true relation of the aurora to magnetic perturbations still remains to be determined. Angot repeats a suggestion which has been made elsewhere, viz.: that many of the difficulties which now present themselves in connection with auroras and magnetic perturbations will disappear if it be understood that, under the one name of aurora, we are now classifying phenomena which may be of very different natures. Let us make one class of auroras embrace those widely extended magnificent displays which are accompanied with magnetic disturbances, and another class those displays which are local in character and more in the nature of manifestations of atmospheric electricity.

There remains little to be said about the relation of sun-spots and auroras, other than

that the agreements thus far made out are, it is to be feared, more apparent than real. We seem, indeed, to be but little removed from the military authorities who, at Copenhagen in 1709, during a very brilliant aurora, ordered that the troops be paraded, the drums beaten and arms presented. We are able to do as little. A. M.

Geological Survey of Michigan. L. L. HUBBARD, State Geologist. Vol. v., 1881-1893. Part I. Upper Peninsula, 1881-1884. Iron and Copper Regions, by Carl Rominger, pp. 179, 3 plates and a map. Part II. Geology of Lower Michigan, with reference to deep borings. C. E. Wright and A. C. Lane, with an introduction by L. L. Hubbard, pp. 100, plates LXXIII. and a map. Lansing, 1895.

The Geological Survey of Michigan is to be congratulated on finally possessing, as we learn from this report, a house of its own, where its collections can be permanently stored and kept together for reference. There is so much complexity in the geology of the Upper Peninsula, and so much importance attaches to the determination of obscure species of rocks, that a permanent home is indispensable, and the sole regret is that it was not earlier attained. The volume before us resumes, in the same style, the series of Michigan reports that temporarily ceased with the issue of Vol. IV., in 1882. Part I. consists of a manuscript of Dr. Carl Rominger, formerly State Geologist, that was prepared about 1882, and has remained unpublished to date. To properly appreciate Dr. Rominger's paper on the iron districts one must place one's point of view back in 1883 and efface from mind as far as possible the work of Irving, Van Hise and G. H. Williams, the reports of Wadsworth, the reviews of Alex. Winchell and many other minor papers on the petrography and stratigraphy of this difficult

region that have appeared since. The Gogebic district, that has proved the key to the structure of the other ranges, had not yet developed a mine when seen by Dr. Rominger, and in the older ranges the 'soft ores,' now the chief source of supply, were looked upon, when known, with more or less contempt. The paper is a further amplification of the author's previous report and is to be considered in this connection. Its chief value to-day is in its historical bearings and in the fact that it does its author the justice of finally issuing his work. Otherwise, lacking, as it is, in sections, geological maps and illustrations, it forms for a general reader a rather disjointed series of observations.

The chapter on the Keweenaw group of copper-bearing rocks stands much better by itself. The geology of the country is much simpler than in the iron regions, and not much important additional work has been done in the last ten years. The report is brought down to date, also, by recently acquired data. Accurately plotted cross-sections afforded by the deep Tamarack shafts, and by long prospecting drifts in the Calumet and Hecla mine, illustrate admirably the astonishing succession of basaltic eruptions that go to make up the Keweenawan formation. The report furnishes thus an excellent short account of the geology of Keweenaw Point, of the adjacent mainland, and of the copper mines. As such it is to be commended to the general reader. When we read of the extensive prospecting and exploration that have so widely opened up the surface and that have so often been without remuneration, we cannot but regret that we do not better understand the laws of the precipitation and distribution of the copper. Despite Professor Pumpelly's brilliant and suggestive thesis, most observers familiar with the mines feel that the whole story has not yet been told.

Part II. is a very valuable contribution, and more than Part I. brings out that which is new. Dr. Hubbard's introduction is timely. It sets forth the views of Ochsenuis on the origin of thick deposits of rock, salt, gypsum and their associates, and places before American readers what is really the only good explanation of their formation. The 'bar theory,' based, as it is, on true chemical principles and necessary geological relations, lays us under obligations to Ochsenuis that are no less important in their scientific than in their economic relations. As applied to petroleum, however, there is little in the geology of our serious oil regions, so far as yet opened up, that indicates any notable connection between the 'mother liquors' of an evaporating estuary and these stored up reservoirs of hydrocarbons. The main part of the paper consists of Dr. Lane's revision and elaboration of notes which were mostly accumulated by the late State Geologist, Charles E. Wright, whose untimely death removed a vigorous worker in the midst of his career. The records of the wells sunk for brines or in the search for oil and gas have afforded a vast amount of valuable information about the stratigraphy of the Lower Peninsula. These have been elaborated by Dr. Lane in a very admirable way. After a brief introduction regarding the gaps in the record, and the errors that creep into observations of this character, a review is given of the stratigraphy of this portion of the State, which is to be commended to any reader who desires a brief account of the thickness and arrangement of the formations. The records are then plotted in numerous diagrams, from which sections are assembled that cross the geosyncline in five or six different places. A descriptive text accompanies the sections, arranged by towns in alphabetical order. The report cannot fail to be of equal interest to scientific men and to those who are engaged in the rapidly growing industries

based on brines and gypsum. Whether an oil field lies under the surface is a question which only the explorations of the future can solve.

J. F. KEMP.

Veröffentlichungen aus dem Königlichen Museum für Völkerkunde. Berlin. 1895.

The above named publication by the Museum of Ethnography in Berlin appears quarterly in large folio form, and consists of special studies by experts in some of the lines of anthropologic science.

The last number, Band IV., Heft 1., deserves separate mention for the valuable contributions it contains to American archaeology. It presents three articles, each of which is a model in its way.

The first is a descriptive catalogue of a collection of idols, fetishes and priestly ceremonial objects from Zuiñi, collected and explained by Mr. Frank Hamilton Cushing, and now deposited in the Berlin museum. It is illustrated with 26 drawings inserted in the text, and the purposes of the objects with their mythological associations are accurately set forth.

The second article is by Dr. Carl Sapper, on 'Ancient Indian Settlements in Guatemala and Chiapas.' It is accompanied by a most useful map of Chiapas, Tabasco, Guatemala and part of Honduras, giving the locations of the ancient native towns, caves containing remains, rock-drawings and localities deserving further investigations. To this are appended 20 plans of ancient ruined cities within the area mapped, a number of them entirely new, others more accurately drawn than in previous publications. Among them may be mentioned the famous Iximche, the capital of the Cakchiquels; Sacabajá, a city of the Quiches; Los Cuyes in the department of Huehuetenango; the rock-inscriptions of Zacualpa in Chiapas, and others. This archaeological study will be of great use to future investigators.

The third article is an interesting study,

by the eminent Americanist, Dr. Carl Seler, of a series of vases and similar objects brought by Dr. Sapper from Guatemala. It is illustrated by 104 drawings inserted in the text, and the subject is elucidated by the thorough acquaintance with the literature of the conquest which the author always has at command. A number of these vases are decorated with hieroglyphs of the form characteristic of the Mayan tribes. Some of these the author identifies with others in the manuscripts and sculptures, and suggests explanations for them. He is inclined to believe that such inscriptions indicate that the vases were manufactured elsewhere than where they were found; an opinion which will not hold, in view of the large number of sherds bearing glyphs obtained from the southern Mayan territory. This essay is a most important contribution to the study of the Mayan hieroglyphs.

D. G. BRINTON.

SOCIETIES AND ACADEMIES.

THE ASTRONOMICAL AND PHYSICAL SOCIETY OF TORONTO.

At a meeting on June 11th the following notes on mass and temperature in the solar system were read by Mr. A. Elvins:

I have long thought that a relation exists between the masses of the heavenly bodies and their temperatures, the heat rising as the mass increases. Mercury is too near the Sun to be observed with much chance of success. Venus is somewhat better situated, but its brilliancy is so great that it is a difficult object to observe; its atmosphere, however, often shows dark patches, which I think may be openings through the general mass of clouds which seem to envelope the planet, reflecting light from their outer surface. Like the earth, I think it has polar caps of snow; I have seen a bright spot at the north pole on several occasions during the past fortnight, and similar observations have been previously

noted by other observers and myself. The mass of Venus approaches nearer to that of the earth than the mass of any other planet, and it will probably not be very different from the earth in its temperature.

In the case of the moon the temperature is probably very low. Peal and others regard it as glaciated. Langley says at full moon the temperature is not above 0° centigrade. I need not remind you that the mass of the moon is very small. The mass of Mars is only about one-ninth that of the earth, and it may be on the whole a colder world. The vast polar caps have a great resemblance to snow; they enlarge during the winter and decrease during the summer. The canals, about which so much has been written, are just as likely to be rents or fissures in ice fields, or vast ice crystals on the surface of liquid, as to be vegetation near artificial streams.

Jupiter is the giant world, and if the temperature increases with mass its heat must be very great. Careful scrutiny sustains this view; no polar snow caps can be seen; the belts and spots show so many changes that the best observers regard the planet as a very hot body. Proctor even contended that it radiated heat to the satellites, and was in that respect an additional sun to them.

This speculation is of great interest to me and I would be pleased sometime to continue the subject, but I think enough has been said to show that it is not void of interest, and that going outwards from the Sun temperature seems to increase with mass. I need scarcely remind you that the mass of the Sun itself is vastly greater than that of all the bodies of the system combined, and that his heat is enormous.

SCIENTIFIC JOURNALS.

AMERICAN CHEMICAL JOURNAL FOR JULY.

THE July number of the American Chemical Journal contains an article by W. F.

Edwards entitled 'Notes on Molecular and Atomic Refractions.' He offered, sometime ago, a new formula, $\frac{P(M-1)}{MD}$, for molecular refraction, and the present paper contains the results of further research and comparisons of the results obtained by the use of his formula with those obtained with the formulæ of Gladstone and Lorentz-Lorenz. He has compared a number of cases of acids and ethereal salt and has determined the change caused by the addition of CH_2 , and the numbers representing the atomic refractions of hydrogen, oxygen, nitrogen, chlorine, bromine, iodine and sulphur, in terms of his formula.

By the use of his formula he can tell whether the nitrogen is present in the trivalent or univalent condition; but with the others this is impossible. Although a great number of observations are available the results are not such as would render any general conclusions possible in many cases. Hite, and Orndorff and Cameron, describe the pieces of apparatus which they have devised for determining molecular weights by the boiling-point method. They both call attention to the great influence of pressure on the boiling point and the necessity of making corrections for it. The two methods vary in details, the apparatus of Orndorff and Cameron being much simpler and easily made by any student, while specially constructed apparatus is needed for Hite's method. Numerous examples are given by both of very satisfactory results obtained.

Seldner has tried parallel experiments to those of Gautier in which diacetamide is formed by heating acetonitrile and acetic acid together. He used glutaric acid and its nitrile, and whether he mixed glutaric acid and acetonitrile, or glutaric nitrile and acetic acid, or glutaric acid and glutaric nitrile, in each case he obtained the same product, the glutaramide. DeChalmot, who has been studying the pentoses of plants, advanced the hypothesis that in

plants pentose molecules are formed in complex molecules of hexosans in which a part or all of the aldehyde groups have been bound by condensation, and are thereby preserved from further oxidation. He considers the pentoses to be formed from hexoses by the end alcohol group being oxidized and then losing carbon dioxide. The investigation was only carried far enough to show that probably the hexosans are oxidized to the aldehyde.

H. C. Jones publishes the results of a method that can be used for the determination of formic acid by oxidizing it with potassium permanganate. The method he used was as follows: After making the formic acid solution alkaline with sodium carbonate, it was treated with an excess of a standard solution of potassium permanganate. The formic acid was all oxidized to carbon dioxide and water. The solution was then acidified and a measured volume of oxalic acid run in until the solution became clear, and the excess of acid determined by the permanganate solution. The two solutions were then compared and the necessary data secured for calculating the amount of formic acid.

Several reviews of books on chemistry are included in this number, the principal one being the review of Palmer's translation of Nernst's 'Theoretical Chemistry.'

J. ELLIOTT GILPIN.

NEW BOOKS.

Zeit- und Streitfragen der Biologie. OSCAR HERTWIG. Vol. I. Jena, Gustav Fischer. 1894. Pp. iv+143. M 3.

Report of the International Meteorological Congress. Pt. II. Edited by OLIVER L. FASIG. Washington, Weather Bureau. 1895. Pp. 583.

The Gospel of Buddha. PAUL CARUS. Chicago, The Open Court Publishing Co. 1895. Pp. xiv+275. 35 cents.

The Cell. OSCAR HERTWIG. Translated by M. Campbell and edited by Henry Johnston Campbell. London, Swan & Sonnenschieden. New York, Macmillan & Co. 1895. Pp. vi+368. \$3.

Hydrodynamics. HORACE LAMB. Cambridge University Press. New York, Macmillan & Co. 1895. Pp. xviii+604. \$6.25.

Transactions of the American Institute of Electrical Engineers. Vol. IX. New York City, The Institute. 1894. Pp. xii+938.

Petrology for Students. A. HARKER. Cambridge University Press. New York, Macmillan & Co. 1895. 12mo. \$2.

The Great Frozen Land. FREDERICK GEORGE JACKSON. New York and London, Macmillan & Co. 1895. Pp. 414. \$3.25.

Anuario publicado pelo Observatorio do Rio de Janeiro. Rio Janeiro, Lombaerts & C 1895. Pp. x+374.

Studies in Spherical and Practical Astronomy. GEORGE C. COMSTOCK. Madison, Wis., The University. 1895. Pp. 106. 40 cts.

Experimental Study of Field Methods which will insure to Stadia Measurements greatly increased Accuracy. LEONARD SEWAL SMITH. Madison, Wis., The University. 1895. Pp. 145. 35 cts.

A Contribution to the Mineralogy of Wisconsin. WILLIAM HERBERT HOBBS. Madison, Wis., The University. 1895. Pp. 156. 40 cts.

On the Quartz Keratophyre and associated Rocks of the North Range of the Baraboo Bluffs. SAMUEL WEIDMAN. Madison, Wis., The University. 1895. Pp. 56. 25 cts.

The Finances of the United States from 1775 to 1789 with especial reference to the Budget. CHARLES J. BULLOCK. Madison, Wis., The University. 1895. Pp. viii+273. 75 cts.

Inductive Psychology. E. A. KIRKPATRICK. New York and Chicago, E. L. Kellogg & Co. 1895. Pp. 208.

SCIENCE

NEW SERIES.
VOL. II. No. 31.

FRIDAY, AUGUST 2, 1895.

SINGLE COPIES, 15 CTS.
ANNUAL SUBSCRIPTION, \$5.00.

GUSTAV E. STECHERT'S

Recent Importation of Scientific Books.

BECKERT, TH. und DR. ALBANO BRAND. Hüttenkunde. Mit 235 in den Text gedruckten Figuren. 765 Seiten. gr. 8^o. Mk. 20.

BHRENS, H. Anleitung zur mikrochemischen Analyse. Mit einem Vorwort von Prof. S. Hoogewerf in Delft. 224 Seiten mit 92 Figuren in Text. 8^o. Mk. 6.

BEIDERMANN, W. Elektrophysiologie. 1^{te} Abtheilung. Mit 136 Abbildungen. 440 Seiten. 8^o. Mk. 9.

BORCHERS, DR. W. Elektro-Metallurgie. Die Gewinnung der Metalle unter Vermittlung des elektrischen Stromes. 2^{te} verm. v. völlig umgearb. Auflage. 1^{ste} Abtheilung, mit 87 Abbildungen. 160 Seiten. gr. 8^o. Mk. 6^{oo}.

BUSCHAN, GEORG. Vorgeschichtliche Botanik der Cultur-u. Nutzpflanzen der alten Welt auf Grund prähistorischer Funde. 268 Seiten. 8^o. Mk. 7^{oo}.

DAMMER, DR. O. Handbuch der chemischen Technologie. Unter Mitwirkung von Direktor Th. Beckert, Dr. Bender, Dr. Benedikt, Dr. Börsheim u. A. herausgegeben. 2^{ter} Band. Mit 235 in den Text gedruckten Figuren. gr. 8^o. Mk. 20.

DELAGE, YVES. La structure du protoplasma et les théories sur l'hérédité et les grands problèmes de la biologie générale. 978 pages. gr. 8^o cloth. frs 24^{oo}.

DETMER, DR. W. Das pflanzenphysiologische Praktikum. Anleitung zu pflanzenphysiolog. Untersuchungen für Studierende u. Lehrer der Naturwissenschaften, sowie der Medicin, etc. 2^{te} völlig unbenutzte Aufl. Mit 184 Abbildungen. 456 Seiten. 8^o. Mk. 9.

FOREL, DR. AUGUST. Der Hypnotismus, seine psycho-physiologische medicinische, strafrechtliche Bedeutung und seine Handhabung. 3^{te} verb. Aufl. mit Adnotationen von Dr. O. Vogt. 223 Seiten. gr. 8^o. Mk. 5.

FRANK, DR. A. B. Die Krankheiten der Pflanzen. Ein Handbuch für Land-Forstwirte, Botaniker, etc. Erster Band, Die durch anorgan. Einflüsse hervorgerufenen Krankheiten. Mit 34 Holzschnitten. 2^{te} Aufl. 344 Seiten. 8^o. Mk. 6^{oo}.

HIS, WILH. Die anatomische Nomenclatur. Nomina anatomica, Verzeichniß der von der anatomischen Gesellschaft auf ihrer 9. Versammlung in Basel angenommenen Namen. Mit 30 Abbildgn. im Text und 2 Tafeln. 180 Seiten. Mk. 7^{oo}.

HOUDAILLE, F. Météorologie agricole. 204 pages cloth. fr. 3.

JAHRBUCH DER ELEKTROCHEMIE. Berichte über die Fortschritte des Jahres 1894. Im wissenschaftlichen Theile bearbeitet von Dr. W. Nernst. Im technischen Theile bearbeitet von Dr. W. Borchers. F Jahrgang. 274 Seiten. gr. 8^o. Mk. 10.

JERUSALEM, WILH. Die Urtheilsfunktion. Eine psychologische und erkenntniskritische Untersuchung. 269 Seiten. Mk. 6^{oo}.

LOEWY, DR. A. Untersuchungen über die Respiration and Circulation bei Aenderung des Druckes und des Sauerstoffgehaltes der Luft. Mit 5 Curventafeln im Text. 155 Seiten. gr. 8^o. Mk. 4.

MEYER, DR. ARTH. Untersuchungen über die Stärkekörner der höheren Pflanzen. Mit 9 Tafeln u. 99 Text-Abbildgn. 318 Seiten. gr. 8^o. Mk. 20^{oo}.

NIEDENZU, DR. FRANZ. Handbuch für botanische Bestimmungsübungen. Mit 15 Figuren im Text. 351 Seiten. 8^o. Mk. 4.

SCHAFFER, DR. KARL. Suggestion und Reflex. Eine Critisch-experimentelle Studie über die Reflexphänomene des Hypnotismus. Mit 6 Tafeln in Lichtdruck und 11 Abbildungen im Text. 113 Seiten. gr. 8^o. Mk. 6^{oo}.

SCHMIDT, DR. ALEX. Weitere Beiträge zur Blutlehre. Nach des Verfassers Tode herausgegeben. 247 Seiten. 8^o. Mk. 7.

SCHWARTZ, TH. Die Lehre von der Electricität und deren praktische Verwendung. Mit 153 in den Text gedruckten Abbildungen. 543 Seiten. 8^o. Mk. 10^{oo}.

STEINHARDT, DR. EUGEN. Kurzes Lehrbuch der Chemie zum Gebrauch an Schulen und zur Selbstbelehrung. Zwei Teile. Erst. Teil; Anorganische Chemie. 418 Seiten. 8^o. Mk. 6^{oo}.

VAN BIEVELIET, J. J. Elements de psychologie humaine. Cours professé a l'université de Gand. Avec 34 figures dan le Text. 317 pages. frs. 8.

ZEITSCHRIFT FÜR ANGEWANDTE Mikroskopie herausgegeben von G. Marpung. Monthly. 1^{ter} Band 1^{tes} Heft. Per year, \$2.75.

ZEITSCHRIFT, Geographische, Herausgegeben von Dr. Alfred Hettner. 1^{er} Jahrg. 1^{es} Heft. Per year (12 N^{os}) \$4^{oo}.

ZIMMERMANN, DR. A. Das Mikroskop. Ein Leitfaden der wissenschaftlichen Mikroskopie. Mit 231 Figuren im Text. 334 Seiten. gr. 8^o. Mk. 9.

ZITTEL, KARL A. VON. Grundzüge der Paläontologie (Paläozoologie). Mit 2045 in den Text gedruckten Abbildungen. 971 Seiten. gr. 8^o. $\frac{1}{2}$ mor. Mk. 25^{oo}.

GUSTAV E. STECHERT,

810 Broadway, New York.

Macmillan & Co.'s New Publications.

Cambridge Natural Science Manuals. General Editor—A. E. SHIPLEY, M. A.
Fellow and Tutor of Christ's College.

NEW VOLUMES.

- I. **Elements of Botany.** By F. DARWIN, M. A., F. R. S., Fellow of Christ's College, Cambridge, and Reader of Botany in the University. With numerous illustrations. (*Biological Science.*) 12mo, \$1.60, *net.*
- II. **Petrology for Students.** By A. HARKER, M. A., F. G. S., Fellow of St. John's College, Cambridge University Demonstrator in Petrology. 12mo, \$2.00.
- III. **A Text-Book of Zoögeography.** By FRANK E. BEDDARD, M. A. (Oxon), F. R. S., Professor of the Zoological Society of London. Maps, 12mo, cloth, \$1.60, *net.* (*Biological Science.*)

The Theory of Light. By THOMAS PRESTON, M. A. (Dub.), Fellow of the Royal Society of Ireland and Professor of Natural Philosophy, University College, Dublin. 8vo, cloth, pp. xii+573, \$5.00, *net.*

Analytical Chemistry. By N. MENSCHUTKIN, Professor of the University of St. Petersburg. Translated from the third German edition under the supervision of the Author. By JAMES LOCKE, Assistant in the Analytical Laboratory of the University of Heidelberg. Pp. xii+512, 8vo, cloth, \$4.00, *net.*

Text-Book of Operative Surgery. By DR. THEODOR KOCHER, Professor of Surgery and Director of the Surgical Clinic in the University of Bern. Translated with the Special Authority of the Author from the Second Revised and Enlarged German Edition by HAROLD J. STILES, M. B., F. R. C. S., Edin., Senior Demonstrator of Surgery and formerly Demonstrator of Anatomy in the University of Edinburgh, etc. With 185 Illustrations. 8vo, cloth, pp. 303, \$3.50, *net.*

On Certain Phenomena belonging to the Close of the Last Geological Period, and on their bearing upon the Traditions of the Flood. By JOSEPH PRESTWICH, D. C. L. (Oxon.), F. R. S., F. G. S., Corr. Inst. France (Acad. Sc.), Acad. R. Lyncei, Rome; Roy. Acad., Brussels, etc. 8vo, cloth, pp. 87, \$1.00.

The Horticulturist's Rule-Book. A Compendium of Useful Information for Fruit-growers, Truck-gardeners, Florists and others. By L. H. BAILEY, Professor of Horticulture in Cornell University. Third Edition, thoroughly Revised and Recast, with many Additions. 12mo, limp cloth, 75 cents.

Hydrodynamics. By H. LAMB, M. A., F. R. S., Professor of Mathematics in Owens College, Manchester. Demy 8vo, cloth, \$6.25, *net.*

A Monograph on the Order of Oligochæta. By FRANK EVERS BEDDARD, M. A. (Oxon.), F. R. S., Professor to the Zoological Society of London, and Lecturer at Guy's Hospital. 4to, stiff boards, linen back, \$12.50, *net.*

Crystallography. A Treatise on the Morphology of Crystals. By N. STORY-MASKELYNE, M. A., F. R. S., Professor of Mineralogy, Oxford, Honorary Fellow of Wadham College. 12 mo, \$3.50, *net.*

The Great Frozen Land (Bolshaja Zemelskija Tundra). Narrative of a Winter Journey across the Tundras and a Sojourn among the Samoyads. By FREDERICK GEORGE JACKSON, Fellow of the Royal Geographical Society, Leader of the Jackson-Harmsworth Polar Expedition. With Illustrations and Maps. Edited from his Journals by ARTHUR MONTEFIORE, Fellow of the Geological and Royal Geographical Societies and Anthropological Institute. 8vo, cloth, pp. 297, \$4.50.

The American Commercial Policy. Three Historical Essays. By UGO RABBENO, Professor of Political Economy in the University of Modena. Second Edition. Partly rewritten and entirely revised by the author. Translated at the Translations Bureau, London. 8vo, cloth, pp. 414, \$3.25, *net.*

MACMILLAN & CO., 66 Fifth Avenue, New York.

SCIENCE

EDITORIAL COMMITTEE: S. NEWCOMB, Mathematics; R. S. WOODWARD, Mechanics; E. C. PICKERING, Astronomy; T. C. MENDENHALL, Physics; R. H. THURSTON, Engineering; IRA REMSEN, Chemistry; J. LE CONTE, Geology; W. M. DAVIS, Physiography; O. C. MARSH, Paleontology; W. K. BROOKS, Invertebrate Zoölogy; C. HART MERRIAM, Vertebrate Zoölogy; S. H. SCUDDER, Entomology; N. L. BRITTON, Botany; HENRY F. OSBORN, General Biology; H. P. BOWDITCH, Physiology; J. S. BILLINGS, Hygiene; J. MCKEEN CATTELL, Psychology; DANIEL G. BRINTON, J. W. POWELL, Anthropology.

FRIDAY, AUGUST 2, 1895.

THE AMERICAN ASSOCIATION FOR THE ADVANCEMENT OF SCIENCE.

CONTENTS:

| | |
|---|-----|
| <i>The American Association for the Advancement of Science</i> | 113 |
| <i>A Rock Fissure</i> : G. K. GILBERT..... | 117 |
| <i>The Metric System in England</i> : T. C. M..... | 119 |
| <i>The 'Ball and Nozzle' Phenomenon</i> : WILLIAM HALLOCK..... | 121 |
| <i>The Present Problems of Organic Evolution</i> : E. D. COPE..... | 124 |
| <i>Philosophy in the German Universities</i> : CHAS. H. JUDD..... | 126 |
| <i>Current Notes on Anthropology (XI)</i> :—..... | 128 |
| <i>The German Anthropological Association, 1894; American Subjects at the German Anthropological Association; American Objects in Nephrite</i> : D. G. BRINTON..... | |
| <i>Physics</i> :—..... | 129 |
| <i>On the Temperature Variation of the Thermal Conductivity of Rocks</i> : T. C. M..... | |
| <i>Scientific Notes and News</i> :—..... | 130 |
| <i>Pithecanthropus Erectus; A Proposed County Park System; General</i> | |
| <i>University and Educational News</i> | 133 |
| <i>Correspondence</i> :—..... | 134 |
| <i>Aboriginal Sandals</i> : O. T. MASON. <i>The Pignuts</i> : WILLIAM TRELEASE..... | |
| <i>Scientific Literature</i> :—..... | 136 |
| <i>Vine's Botany</i> : CONWAY MACMILLAN. <i>Benedikt's Oils, Fats and Waxes</i> : JOSEPH P. GRABFIELD..... | |
| <i>Scientific Journals</i> | 139 |
| <i>American Journal of Science</i> | |

In a few weeks the American Association for the Advancement of Science will begin its annual session, in the city of Springfield, Massachusetts. It is now fifteen years since the Association met in New England, during which time its meetings have been held in various parts of the country, including points as widely separated as Minneapolis in the Northwest and Washington in the Southeast.

The meeting of 1880 was held in Boston and, up to the present time, is distinguished from all others, either earlier or later, by the large attendance, the great local interest manifested and the importance of the papers presented. The meeting at Philadelphia, in 1884, was, perhaps, the closest approximation to the Boston meeting as far as concerns these points, but the latter must still be regarded as the high-water mark in the history of the Association.

It is unnecessary, in these columns, to refer to the history of this Society, as it is, doubtless, very well known to most of our readers. The first meeting was held in the year 1848, in the city of Philadelphia; the organization then accomplished growing,

MSS. intended for publication and books, etc., intended for review should be sent to the responsible editor, Prof. J. McKeen Cattell, Garrison on Hudson, N. Y.

Subscriptions and advertisements should be sent to SCIENCE, 41 N. Queen St., Lancaster, Pa., or 41 East 49th St., New York.

however, out of another, namely, the Association of American Geologists and Naturalists, which had preceded it by a few years. From that year up to the present, with the exception of a period during the Civil War, regular annual sessions have been held, and, indeed, for a time two meetings a year were thought necessary to enable the Society to do its work.

At the meeting at Newport, in 1860, it was agreed that the next meeting, that of 1861, should be held at Nashville, Tenn. However, the course of events, not only as relating to this organization, but to all others, was subjected to extreme modification by the breaking out of the Civil War in the spring of 1861, resulting in the suspension of the meetings of the Association until 1866, when it again resumed its work, holding its first session of the new series in Buffalo, N. Y. The number of members has grown constantly from the beginning, until for several years it has considerably exceeded two thousand.

It is also unnecessary to refer at length to the great importance of the existence of this Association to the scientific interests of the country. Through it students of the various departments of science have been annually brought together, resulting not only in the increase and diffusion of knowledge, but in the cultivation of a fraternal spirit among men working along the same lines, that has had much to do with the great advances that have taken place during the past quarter of a century.

The Society has been from the beginning very largely popular in its character. It has not attempted to restrict its membership by the establishment of conditions

as to professional attainments or knowledge, but, on the contrary, has been fairly open to all who have any desire to be actively interested in the advancement of science. The wisdom of this course cannot be denied, and it has been followed, as is well known, in other countries with equally satisfactory results. It is true that the Society has been at times by some persons rather severely criticised for the liberality with which it welcomes all who desire to become members, and especially for the rather liberal way in which contributions in the way of papers have been received and treated by its controlling committees; but it is believed that a more careful examination of the actual results of this course will prove that, on the whole, it has been a wise one. Scientific men sometimes forget that it is necessary for them to have a constituency, without which it would be impossible for even the most accomplished to enjoy the opportunities and facilities which are necessary for the successful prosecution of their work. It is not even necessary that this constituency should in all cases understand the nature of the work on which the scientific man is engaged, but it is necessary that, in some way, it should be interested in that work and that it should be convinced that, although not understood, it is of value to the human race, either present or prospective. There are Societies in this country, as well as elsewhere, which are organized solely for the benefit of those who are engaged in scientific investigation and research. They have little in their transactions of interest to the general intelligent public, and it is entirely proper that they should exist for the purpose of encouraging and discriminating among those who

devote their lives in a greater or less degree to original investigation. But it cannot be denied that such a Society as the American Society for the Advancement of Science is, after all, of greater value than these, in that it furnishes the channel of communication between the purely abstract scientific work of the very limited number who by nature and occupation can engage in such work and the great intelligent public upon whom such men must, after all, depend for their support and final appreciation.

It has been noted with considerable regret, during the past ten or fifteen years, that a number of the more prominent men of science in the United States have not actively interested themselves in the affairs of the Association. There are several reasons that have been adduced for this, not the least of which is the inconvenience of attending its annual meetings occurring, as they do, during that part of the year which the majority of scientific men have set aside for purposes of recreation and rest. By a small number it has also been objected that the Association has not been and is not maintained in a way to satisfy their desires, in that it has not been sufficiently exclusive in the matter of membership and in the matter of papers which it has permitted to be read and discussed at its meetings. The last excuse for a lack of interest in this work has already been commented upon, and has its origin in a failure to understand the real objects of the Association, and also in a failure to understand the real relation that ought to and in a great degree must always exist between the scientific world and the general intelligent public. The difficulty of attending its

meetings is usually greater for many of those who are quite constant and regular in their attendance than for many others who are much less so. An examination of the list of those present at the various meetings during the past decade will show that New England has fallen very far short of furnishing her quota of membership. One might naturally expect, owing to the large number of institutions of learning, of a high grade, of scientific and technical institutions, and of scientific men independently engaged in original research found within the borders of New England, that her influence would be paramount in the direction and management of the American Association for the Advancement of Science, and so it might be if New England cared to have it so. Some of those who occasionally indulge in criticism upon the conduct of the Association have little excuse for so doing, because they rarely, if ever, attend its meetings, and, therefore, never attempt to direct or control their management. Indeed, it may justly be said that those who have criticised the methods of the Association most frequently and most severely might easily have made it whatever they wanted it to be if they had cared to take enough interest to attend its meetings and use their influence in directing its affairs. The meeting at Springfield will afford an opportunity rather rare for members of the Society both in the East and in the West. Western members will be glad to attend this meeting, because it will bring them within reaching distance of a large number of schools, scientific laboratories, institutions of learning and others which they occasionally like to visit and inspect

and which they can well see before or after the regular session of the Association. Those residents of New England who are members of the Association and those who ought to be members of it cannot, this year, have the excuse of inconvenience and difficulty in attending its meetings. The place of meeting is so convenient that in many cases only an hour or two at most will be required to reach it, and certainly this expenditure of time and energy, even in August, ought not to stand in the way of such attendance. Indeed, New England members should not forget that a very large number of their colleagues in this Association travel several hundreds, and a considerable number of them several thousands, of miles in order to attend its meetings, and it ought to be a matter of pride with them to furnish a respectable quota of membership when the distance is comparatively trifling. In short, it is greatly to be hoped that New England colleges and New England institutions of learning of all classes will furnish a large contribution to the membership of the Association at the meeting in Springfield. It is anticipated that a very large number of members will be present from the West and South, and as the meeting will be distinctively a New England meeting, it is sincerely hoped that New England may be largely and ably represented in the membership.

Very considerable preparations have been made locally for the reception and entertainment of the Association. A number of excursions have been planned, which will be of great interest to those who are interested in different departments of natural science, and, altogether, the preparations

for the meeting are quite as forward and promising as ever before in the history of the Association.

It is particularly desired that a large number of good papers shall be ready for the consideration of the committee before the opening of the meeting. The Vice-Presidents of several of the sections have already indicated their wish that papers might be prepared in advance and forwarded to the committee, that they might be considered and reported upon so as to be put upon the programme early, and they desire that those who are contemplating the presentation of papers at this meeting should act upon this suggestion and forward to their address, that is, the address of the Vice-Presidents shown in the circular of information, as early as possible, a list of titles and subjects for discussion, which will be submitted to the committees for recommendation. Special effort has been made, and a special desire has been expressed by the Vice-Presidents of the sections relating to mathematics, physics, chemistry and mechanics. There are doubtless many persons interested in these subjects who have material which would be of great interest to the Association and which they have contemplated presenting on the occasion of the meeting. From all such these officers hope to receive titles as early as possible, and from others who may possibly be prevented from attending the meeting they would be very glad to receive papers for presentation, which may be read by other members of the section after approval by the proper committee. It is especially to be remembered that membership in the Association is not a necessary preliminary to the presentation

and acceptance of papers. The privilege of reading before any of the sections will be undoubtedly secured to any author of an accepted paper, his election to membership being almost certain to follow the approval of a paper by the sectional committee.

It will be noted by those interested that the meeting of the Association has been put at a somewhat later date this year than usual, the object being to bring it as nearly as may be just before the opening of the fall terms in colleges and other institutions of learning. This change was made after much consideration of the inconvenience to which reference has been made above, arising out of the fact that the meeting of the Association broke into the annual vacation of many of its members. By putting the date a week later, it is believed that the meeting will be found to come more nearly at the end of the vacation for the great majority of its members and that they will, therefore, find it convenient to be present at its meetings after having enjoyed the rest and recreation for which they have arranged during the summer months, and will be able to proceed directly from the meeting of the Association to begin the work of the year.

The British Association for the Advancement of Science has long been the great scientific event of the year in England; its meetings are generally attended by not only the very ablest and the most distinguished men of science in England, but by all ranks of those engaged in scientific investigation, those engaged in teaching science and many hundreds, if not thousands, of those who have only a general interest in the advancement of science. By reason of this very

general and very united effort on the part of all of these various classes, the British Association for the Advancement of Science has long been a power in Great Britain, and to it may be attributed more than to any other organization the wide interest in and generous support of scientific research which is to be found there in a degree greater than in any other country in the world. The American Association for the Advancement of Science should sustain in this country the same relation to the progress of science as that of the British Association in England, and in a great degree it already does; but it must be admitted by all that it falls short of reaching the high degree of efficiency of which such an organization is capable, and it is to be hoped that this state of affairs may be remedied in the near future by the hearty and earnest coöperation, in the support of the Association, of all classes of men engaged in scientific pursuits or interested in the progress of science.

A ROCK FISSURE.

IN the autumn of 1891 the work of the U. S. Geological Survey led me across the Colorado plateau in northern Arizona. Canyon Diablo is a gorge about as broad and deep as the gorge of Niagara, 40 or 50 miles in length, running northward and ending at the Little Colorado River. One day I followed its east wall to the mouth, and then turning westward on the road toward Flagstaff, rode six or eight miles to the McMillan place, where a rude cabin constitutes the headquarters of a sheep ranch. Drinking water for the 'sheep herders' (occidental for shepherds) is obtained from a natural well close by, which

is nothing more nor less than a crack in the rock. The plateau is there constituted of limestone, the Aubrey limestone of the Carboniferous system. The rock is traversed by great faults and flexures, chiefly of

the limestone yields less readily to erosive agents than the soft overlying shale. The crack referred to traverses one of the limestone blocks for a distance of 800 or 1000 feet, and ends abruptly against a fault, as

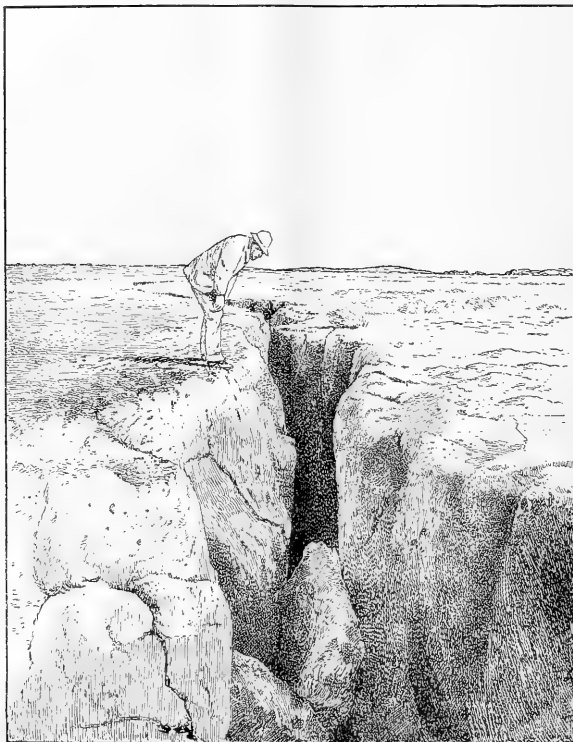

Fig. 1. View of rock fissure, drawn from photograph.

middle Tertiary date, and since these were formed the region has been extensively degraded. In the immediate vicinity of the ranch are several small faults, from 10 to 50 feet in throw, and these are clearly expressed in the topography, not, I think, because they are freshly formed, but because

indicated diagrammatically in figure 2. It is there 6 or 8 feet wide, and it tapers gradually to the other end. In the downward direction it is said to taper also, the width diminishing from 4 or 5 feet to about one foot in 100 feet of descent, at the point where water is drawn. The water, which

is reached at 95 feet from the surface, is probably in motion, as its excellent quality is said not to have been disturbed by the addition of a dozen or so sheep which accidentally fell into the fissure. This last point I could not investigate as the windlass was not in operation at the time of my visit. The occupant of the cabin told me of other cracks of the same character about fifty miles to the northward, and said that one of them was considerably broader and contained cliff houses.

Very little surface water finds its way into the fissure. As shown in the view (Fig. 1) the edge has lost some of its original angularity through weathering, and details of surface which the view does not represent show that waste has been chiefly through solution. The small amount of this waste, and the fact that the fissure is not clogged above the water level by débris, show that it is very young from the geologic point of view, although in years or centuries it may be venerable.

The relation of this deep crevice to a fault and its disassociation from all lines of surface drainage show that it is not a canyon carved by running water, and I see no possibility of avoiding the inference that it is a crack resulting from tension of the rock. Such cracks must be formed at the surface wherever brittle rocks are bent in anticlinal arches, but so far as my reading goes, the

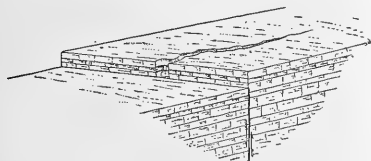

Fig. 2. Diagram showing relation of rock fissure to fault.

record of them is rare. Popular, and for that matter geologic, literature does indeed contain many allusions to fissures that are

assumed to be diastrophic, but such allusions are usually based on misinterpretation, the fissures being really canyons of erosion. Whymper, in his 'Travels amongst the Great Andes' (pp. 108, 219, 220), describes a number of 'earthquake quebradas' which seem to be true fissures, and tradition makes them recent, the date 1868 being assigned to one of them. I am not aware that any have been previously described from North America excepting, on the one hand, cracks in alluvium produced by earthquakes, and, on the other, rock fissures partly or wholly filled by vein matter and afterward denuded.

The reader who wishes to visit the locality should leave the Atlantic and Pacific railway at either Winslow or Canyon Diablo and secure private conveyance.

JULY 18, 1895.

G. K. GILBERT.

THE METRIC SYSTEM IN ENGLAND.

ON the 13th of February last, a select Committee of the House of Commons was appointed 'to inquire whether any and what changes in the present system of Weights and Measures should be adopted.'

There were seventeen members of the committee, including Sir Henry Roscoe, Mr. Justin McCarthy, Sir Albert Rollet, Mr. Charles Fenwick and others, some of whom were known to be in favor of a change, and others equally well known to be opposed to any essential modification of the existing system. The Committee had power to send for Persons, Papers and Records. In all fourteen sessions of the Committee were held, the first being on February 19th and the last on June 27th. During this period many witnesses were examined representing many different interests, including official, commercial, manufacturing, trade, educational and professional. On July 1st the Committee made a Report to the House of Commons, the essential features of which received the

approval of every member of the Committee but one. Some of the conclusions reached are extremely interesting and important. It was found that "with a single exception, all the witnesses express a strong opinion as to the complicated and unsatisfactory condition of our present weights and measures, and of the distinct and serious drawback to our commerce, especially our foreign trade, which this system entails, differing as it does from the system (metrical) now adopted by every European nation excepting ourselves and Russia, as well as by far the majority of non-European countries with which this kingdom trades. The evidence, however, goes further to show that not only is our foreign trade, in every branch, seriously handicapped, but that the home trade would be benefited if more simple and uniform standards of weights and measures than those now existing were adopted."

On the question of loss of time during the educational period of English due to the complicated and cumbersome system "it was stated that no less than one year's school time would be saved if the metrical system were taught in place of that now in use." Evidence was also produced to show that the change from the present to the metric system could be accomplished without serious opposition or inconvenience.

The Committee finally recommended as follows:

(a) That the metrical system of weights and measures be at once legalized for all purposes.

(b) That after a lapse of two years the metrical system be rendered compulsory by Act of Parliament.

(c) That the metrical system of weights and measures be taught in all public elementary schools as a necessary and integral part of arithmetic, and that decimals be introduced at an earlier period of the school curriculum than is the case at present.

A Parliamentary report so positively favorable as this marks an epoch in the history of metrology. Hitherto the well known conservatism of the English has prevented action friendly to the metric system, although many famous Englishmen have been consistent and aggressive advocates of its adoption. The time has come, however, when the most sensitive nerve in the British body politic is touched by this persistent adherence to an unscientific, unpractical and uneconomical system of conducting barter. The manufacturing and commercial interests have learned within the past decade that they are handicapped by this in the markets of the world. When this fact is fully impressed upon the English people there will be prompt and decisive action.

The event ought to be a warning to the United States. It cannot be denied that a decided advantage will accrue to whichever of the two great English-speaking nations shall first put itself in line with the rest of the world in this, one of the greatest economic reforms of the nineteenth century. Up to the present time, we have been, on the whole, in advance of England. We made the system permissive in 1866, and have encouraged its use by fragmentary legislation since that time. But unless we mean to be left behind, we must shortly do something in the way of a definite plan for the complete adoption of the system. The advantages of the metric system should be vigorously exploited and kept continually before the public during the next year or two.

The recent success in England is largely due to the perfect organization and skilful direction of 'The New Decimal Association,' of which Mr. Edward Johnston is the efficient Secretary. This body took the initiative in the presentation of the advantages of the metric system and has carried on an extensive and successful educational campaign.

T. C. M.

THE 'BALL AND NOZZLE' PHENOMENON.

THE interest which has been recently shown in the phenomena of the 'ball and nozzle' must be the excuse for the present publication of some experiments which were made and described about eighteen years ago, while a sophomore at college. At that time I was of course ignorant of Bernoulli's well known theoretical conclusion that in such cases the pressure is always least where the velocity is greatest. The experiments with the water surface could be so modified as to be shown in a projection lantern. I have preferred to print the text and figures without alteration.

WILLIAM HALLOCK.

PHYSICAL LABORATORY,
COLUMBIA COLLEGE, N. Y.

It is an apparently inexplicable fact that if we take two cards as A B and C D, Fig. 1, and through the middle of the lower C D, bring a tube G, as shown in Fig. 1, A B being held about one-fourth of an inch from C D by four tacks, or some such means, that if a current of air is set in motion through G, no matter how slight, or how strong, A B, instead of being immediately blown up and carried away upon the current, retains its position and is even drawn down closer to C D and held there by a force directly in proportion to the velocity of the current in G. Even a quick, strong puff can not remove it, and, in fact, we can in no way remove A B from over C D by blowing through the tube G.

The explanation of this fact seems to consist of two parts: First, why A B is not blown off as soon as a current starts in G and before any eddies, or whirlpools could be formed between A B and C D. Second, what currents are formed between A B and C D, and what action of theirs holds A B over C D. The first of these two actions is that of the first instant, the second is that of the subsequent time until the current in G ceases. During the first

instant we have the current from G pressing upon a small circle of A B directly over the mouth of G. This surface is represented as included between E and F, Fig. 1. Hence all the force tending to raise the card is applied to the surface E F and by the very compressible and yielding column of air from G. The resisting forces which tend to hold the card down are its weight and inertia applied over its whole surface, and add to these two the fact that, in order to raise A B suddenly by pressure over E F, we must either lift all the air above A B along with it, thus rarefying the air between A B and C D, or we must compel the air just above A B to rush around it; even if the air G should fill the space left under A B as it is lifted up, still we should have to overcome the weight and inertia of a large quantity of air. Thus upon comparing the conflicting forces at work upon the card A B we find only the slight force of the current upon E F tending to raise A B resisted by the weight and inertia of A B and also the weight or inertia, or both, of a large quantity of air; and it would seem quite reasonable that the latter should prevail. The brevity of the time and the delicacy of the forces make experimenting very difficult.

In experimenting to confirm the theory of this first action, the lifting force applied at E F remained constant, and the resisting forces were lessened by reducing the size of the card, since by so doing its weight and inertia were lessened, and also the amount of air set in motion. Making A B smaller and smaller, a size is finally reached when A B would be lifted off by the first puff, but if held a second or two until the currents are all started it stays on of itself, *i. e.*, the lifting force at E F is now able to overcome the above mentioned resisting forces; this inferior limit to the size of A B is shown in Fig. 2. If we pass below this limit, as Fig. 3, A B will be

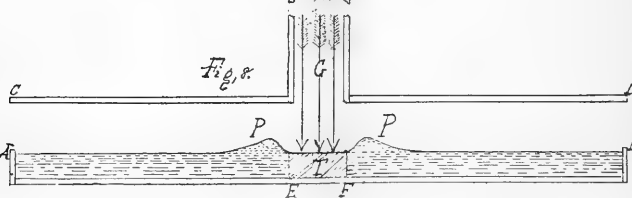
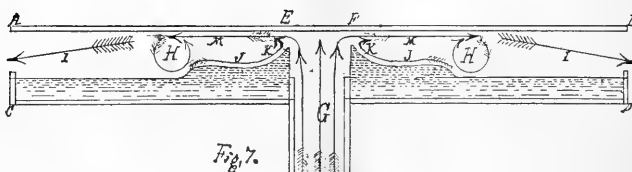
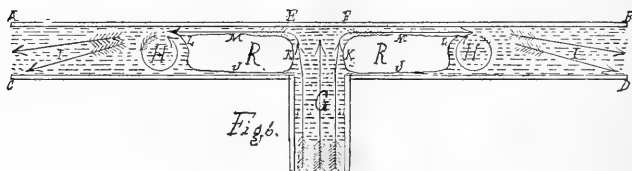
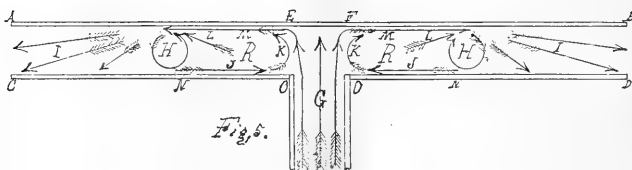
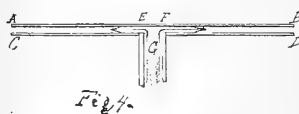
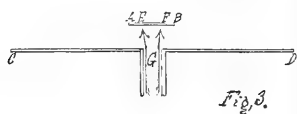
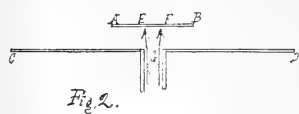
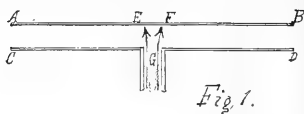

blown off every time. The size of A B, Figs. 2 and 3, varies as the square of the radius of G, and as the distance of A B from C D.

This seems a sufficient confirmation of the theory of the action of the first instant of time.

The subsequent action can be explained as follows: Fig. 5. The current from G, rising strikes A B on E F and spreads out in a direction M, passing on along M at some point H, the current M forms a whirlpool H and spreads, taking most or all of the air beyond H slowly along with it, out from between A B and C D. The currents G and M gradually attract and draw with themselves a part of the dead air in R and form a current K. The tendency of a current is to draw into, and along with itself, the adjoining dead fluid through which it flows. M and H thus drawing the air from R start a current L, which gradually draws out air from R, thus causing a slight vacuum directly over O N, and the pressure of the atmosphere on O N tends to press the two cards together to fill the space R. C D cannot rise, being fast to the tube, so A B is bent down until the space between F and O is just sufficient for the air from G to pass out through, *i. e.*, when A B and C D are separated by a distance equal to one-half the radius of G. This is shown in Fig. 4. The instant this limit is reached the action of Fig. 5 is replaced by that of Fig. 4, and the card by its own elasticity and the pressure over G rises and the action of Fig. 5 is restored. Thus in almost all cases the card vibrates rapidly. The experiments to confirm this theory were made almost entirely with water, since the results and actions would be the same and it was more convenient. The apparatus used consisted of a piece of thin board with four upright wires near the corners, upon which slid a second board; this was so arranged in order that the distance from A B to C D could be

varied at pleasure. Instead of introducing the tube G through the middle of the board C D, it was placed in the middle of one of its sides, and over this edge was placed a plate of glass. This arrangement was to obtain a view of the currents in a section through the center of G and perpendicular to A B and C D. Placing this apparatus in a tub of water, with the plate of glass parallel and near to the surface, and pouring muddy or colored water through G, the currents take the directions represented by the arrows in Fig. 5. To further test the action of the currents M and H in drawing the water from R, a bubble of air was introduced in front of G before the current started, and on starting the current in G the bubble separated and each half assumed the shape shown in Fig. 6, R R, and the air was rapidly drawn out in little bubbles at L, and driven out in a direction I. To confirm the theory that the force which holds the cards together is applied at O N of the bottom card, and in order to find where the currents increased and where they diminished the pressure of the atmosphere, a surface of water was substituted for the lower card, and, again obtaining a sectional view with the plate of glass, it was found that the surface of the water assumed a shape whose section is shown in Fig. 7; thus proving very conclusively that the pressure of the atmosphere upon the surface of the water was diminished to some little extent by the currents M and H, and that here we have the whole cause of the apparently strange action of the card. On substituting a surface of water for the upper card A B, a section shown in Fig. 8 was obtained; thus showing that the only effect of the currents upon A B is the pressure at E F. These four experiments, Fig. 5, with colored water and Figs. 6, 7 and 8, seem to sufficiently establish the above theory of the cause of the card being drawn down after the first instant. The theories of the action at the be-

ginning and during the continuance of the current from G being established, and as the whole action is comprehended in these two periods of time, this apparently inexplicable fact would seem to be explained.

THE PRESENT PROBLEMS OF ORGANIC EVOLUTION.*

At the outset of a conference on the subject of evolution, it is necessary that we understand what we mean by the term. Evolution is creation by energy which is intrinsic in matter, and is not creation by energy exclusively without the evolving matter. Those who explain creation by interference from an external creative power are not therefore evolutionists. This view of creation is opposed to the natural tendency to account for phenomena not otherwise explainable, by an appeal to a supernatural cause. If we desire to know the truth, however, in this or any other matter, it is necessary to divest ourselves of prepossessions and preferences, and rely exclusively on the evidence. But the result of this method in the case of organic evolution is to demonstrate, in my opinion, that the elements of mind have had an important place in the process and have materially influenced the results.

The evidence for organic evolution, it is well known, is derived from three sources: First, the spontaneous variations from uniformity of structure, frequently observed in plants and animals; second, the regular succession of forms displayed in the history of life, taught by the science of paleontology; third, the recapitulation of the same succession, more or less completely, in the embryonic histories of organic beings. As time passes on, the evidence of the origin of species and the groups into which they fall by

modification during descent from preëxistent forms becomes more and more perfect.

The problems presented by the preceding facts for solution may be embraced under two heads: (1) how are the variations or changes in individuals produced? and (2) when produced, are they inherited and so accumulated, or not?

The question as to the cause of variation is difficult of solution. The attempt to solve it must be preceded by a knowledge of what the lines of variation which constitute evolution have been. These are presented by the study of the life of past geologic ages. From this source we learn that there has been a successive improvement in the mechanisms of organic beings. Since the mechanisms are constructed of always plastic, and for a time growing, material, it looks probable that they have been produced by the movements of the organism itself. This suspicion is made a certainty when we learn that new mechanisms are readily constructed by organic beings, to take the place of their normal ones which have been injured or lost. The annals of surgery and of orthopedic hospitals are full of such cases, and the lower animals are still more capable of producing new structures to take the place of old ones than is man. I do not mean by this the reproduction of lost parts, as in the case of the crab and its pincer; but I mean the construction of a new joint or segment in a new place, which is obviously moulded by the mechanical action of the parts.

The movements of animals have led their progressive evolution, and a great many structures have been modified in consequence in ways which are indirect, and whose characters do not always betray their real efficient cause without full investigation. *Per contra*, the absence of motion has resulted in degeneracy and retrogressive evolution. This is amply demonstrated by the results of parasitism. Parasites are always degenerate. This is the

* Abstract of a lecture by Professor E. D. Cope given at the opening of the *Conference of Evolutionists* at Greenacre-on-the-Piscataqua on July 6th and reported in the *Boston Transcript*.

doctrine of use and disuse of Lamarck, precisely defined and demonstrated.

The cause of the movements of organic beings are various. The best known are conscious states, as hunger, cold, heat, and various other sensations; some of them of higher mental grade, as fear, anger, etc. Movements by the lowest animals, as that drop of jelly, the *amœba*, appear to be the result of sensations, but owing to the simplicity of the structure, it is easy to doubt that this can be the case. It is, however, impossible at present to assign any other cause to some of the movements even of the *amœba*, although it must be admitted that our knowledge is slight. The phenomenon of heliotropism, for instance, when these simple creatures leave the dark and crowd into light places, cannot be shown to be due to chemical or physical causes only. They seek oxygen, which is more abundant where sunlight penetrates, but they have to be aware that they need it, and must have some knowledge of the fact when they get it. This indicates a low grade of consciousness. But it is consciousness, nevertheless. But whatever may be the state of the case with the *amœba*, we do not have to ascend far above it in the zoological scale before we meet with clear evidences of the presence of sensation. Hunger, for instance, is a form of consciousness, although it is due to a physical condition.

The result of progressive evolution in animals is developed mechanism of motion, which enables an animal to change or make its environment; and improved intelligence, which serves as a guide in all the contingencies of life. The result of retrograde evolution is the reverse of this. It is probable that no progressive evolution could have taken place without the presence of sensation. As an illustration of retrogressive evolution on a grand scale, we have the vegetable kingdom. Originally freely

moving *amœbas*, the ancestors of plants became sessile or earth parasites. The result is that they have become bound to their environment, which they cannot change. They have therefore to suffer enormous destruction. To counteract this they have developed equally enormous powers of reproduction. In fact, although the vegetable kingdom is essential to the existence of the animal kingdom, for itself it has accomplished progress in but one direction, that of reproduction.

The contrast presented by the animal kingdom is great, and as the result has been man it is evident that the process has been as a whole progressive. The element of sensation at the bottom of it has been probably the central directive point, like the live bud on the apex of a tree. Though of limited local distribution, it has led the way, and all other modifications have followed.

The other problem for solution to which I have referred is that of inheritance. The inheritance not only of the characters of species, but of individual and family traits, is commonly accepted as a fact. But many things are not inherited, such as injuries to the organism, except in very exceptional cases, so that it has been questioned whether any character acquired by the organism during its life can be inherited. But so far as regards certain characters already referred to as having been acquired by movements of the parts, it is clearly proved that they are inherited, as they are found in the embryo before birth, and were therefore inherited by the offspring directly from the parents and were not produced by themselves. It is evident that the characters of the vertebrate skeleton were acquired through motion, or use, by gradual accretions of modifications, and that these modifications were inherited by the successive generations. Each generation added its quota to the result, which thus steadily pro-

gressed to completion. This was reached when the structures fully met the stresses and impacts, which became therefore too feeble to be further effective.

We have here then demonstrated the effect of known agencies in the production of variations. These are not the only ones which are active. The effects of light, temperature and humidity have been studied and the results noted, and it is evident that such effects have been also inherited. Evolution under the influence of such causes I have called physiogenesis, while that which results from the mechanical effects of motions I have termed kinetogenesis. The results of these processes have been submitted to the tribunal of natural selection, and the best have survived. As the direct mechanical effects of use are, however, the best obtainable under the circumstances, it is evident the natural selection in a good many cases has to do only with the struggle between the widely different types of life which are associated together in a given fauna or flora, and not so much between the individuals of each species.

The energy of progressive organic evolution is thus excluded from the domain of chance, by the transmission of all kinds of stimuli through a medium of consciousness, which has its distinctive effect on the response.

PHILOSOPHY IN THE GERMAN UNIVERSITIES.

A BRIEF summary of the lectures announced for the summer semester at the German universities may serve to show the present status of philosophy in these institutions. The lectures here enumerated include only those offered by the philosophical faculties. No attempt is made to mention all the names familiar to American readers, but merely the most important.

The summary is as follows:

Berlin. Professor Paulsen—History of

Modern Philosophy with reference to the general development of modern civilization; Psychology as the basis for all the special philosophical sciences; Ueber das Akademische Studium; seminar, Kant's *Critique of Pure Reason*. Professor Stumpf—Logic and Theory of Knowledge; seminar, Theoretical and Experimental Psychology. Professor Dilthey—History of Philosophy; seminar, History of Modern Philosophy. Other courses: History of Philosophy; History of 19th Century Philosophy; History of Ethics; History of Æsthetics; Neoplatonism; Elementary Questions in Philosophy; Psychology with demonstrations; Social Psychology; Philosophy of Religion; Practical Morals; Æsthetics; Pedagogy.

Leipzig. Prof. Wundt—Psychology; Psychological Laboratory. Prof. Volkelt—Kant's Philosophy; History of Pedagogy from the Renaissance; in seminar, Aesthetics of the Lyric. Other courses: Introduction to Philosophy and Logic; Chief Problems of Philosophy; Selected Questions in Metaphysics; Psychology of Hearing; Pedagogy; Seminar on Ethical Questions and Theory of Knowledge based on Locke's Essay; *Lecture*, Kant's *Prolegomena*.

Halle. Prof. Erdmann—Psychology; Elements of Physiological Psychology; History of Pedagogy from the beginning of the 18th century; seminar, Kant's *Critique of Pure Reason*. Prof. Vaihinger—Introduction to Philosophy; Logic; in seminar, Pedagogical Psychology, with special notice of Herbart's pedagogical writings. Other courses: History of Philosophy; Philosophy since Hegel; Logic; Limits of Human Knowledge; Recent Investigations in Deductive Logic; Ethics; Pedagogy; Seminar on Aristotle's '*De anima*' and Mill's *Logic*.

Jena. Prof. Liebmann—Metaphysics; History of Ancient Philosophy. Prof. Eucken—History of Philosophy since Kant; Philosophy of Religion; Introduction to Philosophy; Philosophical Terminology.

Other courses : History of Philosophy from the Renaissance to Kant; Elements of Psychology; Empirical Psychology; Logic; Pedagogy, with special reference to Herbart.

Strassburg. Prof. Windelband—Logic; Philosophy of Religion; in seminar, Leibnitz's '*Nouveaux Essais*.' Professor Ziegler—History of Ancient and Mediæval Philosophy; Schleiermacher's Life, Philosophy and Theology; seminar, Herbart's '*Einleitung in die Philosophie*.' Other courses: History of Philosophy from the Renaissance; Carlyle.

Göttingen. Professor Müller—Philosophy of Nature; Laboratory for Experimental Psychology. Professor Baumann—Elements of Moral Philosophy; in seminar, Plato's '*Symposium*.' Other courses: History of Philosophy; Kant's Critical Philosophy; Philosophy of Religion (two courses); Pedagogy.

Freiburg im B. Professor Riehl—Problems of Philosophy; Intellectual Life of today and its Chief Tendencies; seminar, Kant's *Critic of Pure Reason*. Other courses; History of Philosophy from the Renaissance to Kant; in seminar, Spinoza's *Ethics*.

Munich. Professor Lipps—Aesthetics; Psychological Questions of the day; in seminar, Psychology. Other courses: History of Modern Philosophy; Psychology; in seminar, Kant's *Critic of Pure Reason*.

Tübingen. Professor Sigwart—History of Modern Philosophy; Ends and Methods of the Philosophical Sciences. Other courses: Introduction to Philosophy and Logic; Psychology; Significance of Philosophy for the Science and Culture of our Time; Fundamental Questions of the Philosophy of Religion; seminar, Kant's *Critic of Pure Reason*.

Erlangen. Professor Falckenberg—Logic and Introduction to Philosophy; seminar, Kant's *Prolegomena*. Other courses: Theory of Knowledge and Metaphysics; Philosophy of Religion; Anthropology.

Greifswald. Professor Schuppe—Psychology; Philosophy of Law; seminar, History of Philosophy. Professor Rehmke—Ethics and Pedagogy; Philosophy of Religion; in seminar, Logic.

Heidelberg. Professor Fischer—History of Greek Philosophy; Critical discussion of Goethe's *Faust*. Other courses: Kant's Theory of Knowledge; Psychology in Relation to Theology, Jurisprudence and Philology; Anthropology; Pedagogy.

Breslau. Prof. Ebbinghaus—Logic and Theory of Knowledge; Kant's Philosophy; Laboratory for Experimental Psychology. Other courses: Introduction to Philosophy; Logic; Aristotle's Philosophy and History of its Influence.

Giessen. Prof. Siebeck—History of Philosophy to Kant; Descartes' '*Meditationes*,' seminar for advanced students. Other courses: Philosophy of the Present Time (including Psychology in England and France); Logic; Pedagogy; Schiller's Philosophical Poems.

Marburg. Prof. Natorp—Psychology; Philosophical Seminar. Other courses: History of Modern Philosophy; Kant's Philosophy; Ethics; Aesthetics; God in German Philosophy and Literature of the 18th Century; in seminar, Descartes, Kant's *Prolegomena*.

Kiel. Professor Deussen—History of Philosophy, first half from the first beginnings of Philosophy in India and Greece to the Christian era; Interpretations of Philosophy; Sanskrit Texts; Selections from Greek Philosophy. Other Courses: Logic; Logic and a Survey of the Sciences; Aesthetics; *Lecture*; Rousseau.

Bonn. History of Philosophy from Kant to Hegel; Psychology; Ethics; Logic; Pedagogy; Experimental Psychology.

Königsberg—History of Greek and Mediæval Philosophy; Logic and Metaphysics; The Immortality of the Soul.

Würzburg—History of Modern Philos-

ophy; Logic and Theory of Knowledge; Esthetics of Music.

The tendencies shown by this summary are by no means new. It appears very clearly that logic and the theory of knowledge are absorbing much more attention than any form of speculative metaphysics. The rapid development and widespread interest in psychology are evidenced by the fact that in the nineteen universities mentioned there are no less than sixteen courses of lectures devoted to this subject. In many places work is also being done in laboratories and seminars. Kant's Philosophy receives very general attention. Five courses of lectures are given on his system, besides the seminary work. The historical work covers all periods, starting with Professor Deussen's investigations in old Sanskrit and Greek Philosophy and extending to the philosophy of to-day.

CHAS. H. JUDD.

LEIPZIG.

CURRENT NOTES ON ANTHROPOLOGY (XI).

THE GERMAN ANTHROPOLOGICAL ASSOCIATION, 1894.

The full proceedings of the meeting of this Association, held last August at Innsbruck, have recently been published in the *Mittheilungen* of the Anthropological Society of Vienna.

The topics discussed were largely of local interest, such as the somatology and prehistory of Tyrol, the prehistoric monuments of Switzerland, the construction of the German house and the recent archæologic finds in central Europe. Of wider scope was the address of the honorary president, Dr. Virchow, who tackled the questions of the origin of man and of the races of men; of Dr. Palacky, of Prague, who filed a brief in defence of the Biblical chronology; of Dr. Virchow again, who delivered a most instructive address on the pygmy races of the

world and the phenomenon of dwarfness generally; of Professor Sergi, of Rome, on the same subject, especially the pygmies of Europe; of Professor Ranke, on the dependence of the erect stature on the development of the brain; of Dr. Mies, of Cologne, on the relations of the weight of the brain to growth; and a very learned and able summary by the president, Baron von Andrian, on 'Some results of modern ethnology.'

This was the twenty-fifth meeting of the Association, and the comparisons drawn by Dr. Virchow between the present state of anthropologic science and what it was a quarter of a century ago were instructive and entertaining,

AMERICAN SUBJECTS AT THE GERMAN ANTHROPOLOGICAL ASSOCIATION.

NATURALLY enough, America did not come in for a large share of attention at the German Association; but it was not wholly overlooked. Mr. Reber compared the cup-shaped markings on certain rocks in Switzerland with similar specimens in America; but he was sharply set to right by Dr. Von Den Steinen, the celebrated explorer of Brazil, with the remark: "I pointedly warn against any such supposition. All attempts to throw ethnographic bridges between the Old and New Worlds have hitherto completely failed." Dr. Von Luschan, however, referred to the modern Tyrolese feather work as having been introduced from Mexico; though that was of course quite a recent bridge. Dr. Palacky, in his paper above named, denied that there is any parallel in time or character between the ice age in America and Europe; but offered no clear reasons for saying so. Dr. Virchow, in discussing dwarf races, spoke of some very small (Nannocephalic) skulls from southern Venezuela and Columbia, but did not assert that they indicated a pygmy tribe there resident, as his argument

rather was that the cerebral capacity does not necessarily prove that the person who carried the skull was of extremely low stature. In fact, up to the present time, though individual dwarfs are known to have existed in America, and are even said to have been artificially cultivated in Mexico for the amusements of the nobles (!), no dwarf tribe has yet been discovered.

AMERICAN OBJECTS IN NEPHRITE.

The proceedings of the Berlin Anthropological Society for January last contain a description by the well known archæologist, Dr. A. Ernst, of Caraccas, Venezuela, of three nephrite axes from that region, one of them found by himself. All three are of rather clear, green color, not presenting the milkiness of the so-called Chinese article—A trait which characterizes the specimen from the same locality which has long been in the Museum of Berlin, and which particularly attracted the attention of the late Dr. Heinrich Fischer, and which he dwells on as important in his classical work, 'Nephrit und Jadeit' (pp. 7, 347).

It is true that up to date we do not know the deposit from which these South American species were taken, but it seems a long way to go to look for it in Burmah or Turkestan, as some would advise. Mineralogists are now of the opinion that neither the coloring nor the chemical composition of these allied minerals is sufficient to designate their source. A better criterion is their microscopic structure. This presents marked and peculiar differences, and if the American specimens could not be traced to any known site on this continent, and presented all the lithological traits of the Asiatic article (which they do not, in as far as examination has proceeded), then there would be some basis for such speculations.

D. G. BRINTON.

UNIVERSITY OF PENNSYLVANIA.

PHYSICS.

LORD KELVIN AND MR. MURRAY 'ON THE TEMPERATURE VARIATION OF THE THERMAL CONDUCTIVITY OF ROCKS.*'

IN the recent interesting revival of the question of the probable 'Age of the Earth' it has developed that it would be very convenient if it were known whether rocks conduct heat more readily when hot than when cold. Not much was known on this point, and the research bearing the above title was carried out with a view to determining whether conductivity varied with temperature, and if so whether directly or indirectly. In a general way, the plan of the experiment was to produce a steady flux of heat between the two ends of a column of the rock under examination, the temperature of these ends being kept constant, and then to measure the temperature at three points within the column arranged in a line coincident with the flux line. The ratio of the mean conductivities for the portions of the rock between the first and second points and the second and third would then be defined by Fourier's theory of conductivity, as a function of the steady temperature at these points and the distance between them.

The columns of rock were not large, being generally about three or four centimetres square and six or eight centimetres high, although somewhat larger in one or two cases. They were split in halves in a vertical plane parallel to the flux line, to allow of the introduction along the centre line of thermo-electric junctions consisting of platinoid and copper. These were of wire fitted in small grooves, and the two parts were then pressed tightly together so as to resemble an unbroken column as nearly as possible. The lower end was kept at a nearly constant high temperature by means of a bath of molten tin. The upper surface was covered with mercury into which the

* A paper read before the Royal Society on May 30.

heat flowed easily, being carried off by a quantity of cold water resting on it, the water being continually renewed so as to maintain at this end nearly a constant low temperature. The difference of temperature between the two faces was about 200° C. The most successful experiments were made on slate and granite. Each experiment lasted about two hours, and after the first hour the temperature of the three thermo-electric junctions remained sensibly constant.

The results showed in both cases that the conductivity at the higher temperature was less than at the lower. The differences were very decided and such as must certainly be taken into account in all discussions of the transmission of heat by conduction in hot bodies. The work is very important and should be, as it doubtless will be, extended to greater variety of material and wider range of temperature.

T. C. M.

SCIENTIFIC NOTES AND NEWS.

PITHECANTHROPUS ERECTUS.

MR. ARTHUR KEITH contributes to the July number of *Science Progress* a careful account of human fossil remains; he summarizes his conclusions as follows:

“Our human geological record stretches as yet back only to an early post-tertiary period.¹ The millions of men that must have lived in these early times are known to us by only four specimens complete enough to permit of their reconstruction. But, taking these as samples of their race, we can say with some assurance that man has not changed much since the Tertiary period of the earth's history closed. The majority of men were distinctly and considerably smaller-brained than the great majority of the men that now people the earth's surface. Their faces, jaws, teeth and muscular ridges were more pronounced. Since Tertiary times the human structural progress

has lain in an increase of brain and a diminution in the masticatory and alimentary systems. In these features we may suppose that early Quaternary man approached the primate ancestors of the race; in these features he certainly comes nearer the present simian type. But, for the purpose of giving us a clue to the human line of descent, the fossil remains at present known assist us not one single jot. Their configuration is quite conformable to the theory of a common descent; they bear out the truth of that theory. They also show us that man since the Tertiary period has changed structurally very little. There is nothing remarkable in this, for allied primitive forms (*Paleopithecus sivalenses*¹ and *Dryopithecus*²) demonstrate to us that, since the Miocene period, the anthropoid type has changed but slightly. We need not then be surprised at being obliged to seek deep within the Tertiary formations the evidences of human descent.”

A PROPOSED COUNTY PARK SYSTEM.

At a recent meeting of the Natural Science Association of Staten Island, Mr. Walter C. Kerr, President of the Association, read a paper on ‘A proposed County Park System.’ Mr. Kerr urged the desirability of putting into execution, before it is too late, some plan to preserve what still remains of the dense forests which covered the island in earlier times. He does not consider it feasible to establish at once a series of parks with the attendant expenses of immediate improvements, but simply “the purchase by the county, at reasonable prices, of various tracts to be held as public land, and eventually, when the county becomes more densely populated, to become a park system joined by county roads. The larger and more distant tracts, however, would possess, as the years go by, an interest far greater than any conventional park could yield, for with the extensive flora of

this island, including 1,320 plants out of about 1,800 in the whole State, a little care and skill would soon convert these areas into botanical museums without destroying their rugged wildness. In this respect a word may not be amiss concerning the advanced and most practical ideas of what should constitute a park. The days of gravel walks, iron benches and notices to 'keep off the grass' have passed, while landscape gardening has in the hands of masters of the art become largely the preservation of nature rather than supplanting it with forced growths. Asphalt drives have yielded to woodland roads, while paths wind through the valleys and between the trees instead of the trees bordering paths laid out in geometrical lines and curves. One of the oldest parks in Chicago is being modified from its conventional character and devoted to the display of native wild plants and flowers that grow or have grown within twenty-five miles of the city."

GENERAL.

STEPS are being taken toward the erection of memorials in honor of Huxley. The Dean of Westminster has signified his willingness that a tablet be placed in the Abbey. It is proposed to establish at Charing-cross Hospital Medical School, of which Mr. Huxley was a student, an annual lecture and a science scholarship and medal. It is also suggested that a statue of the deceased naturalist should be placed in the great hall of the Museum of Natural History at South Kensington, beside those of Darwin and Owen.

THE *American Naturalist* reports an address by Mr. Hedley on the faunal regions of Australia given before the Adelaide meeting of the Australian Association for the Advancement of Science. Mr. Hedley concludes that "superimposed, one above another, may be distinguished three divis-

ions of Australian life. The earliest is the Autochthonian. Possibly this arrived from the Austro-Malayan islands in or before the Cretaceous era and spread over the whole of Australia. The next is the Euronotian. Probably this reached Tasmania from South America, not later than the Miocene epoch; many of the original inhabitants, particularly on the east coast, probably disappeared before the invaders. Thirdly, a contingent of Papuan forms seized on the Queensland coast, late in the Tertiary, and likewise largely exterminated their predecessors."

PROFESSOR SWARTZ, Baron von Müller and Professor Engelmann have been elected correspondents of the Paris Academy of Sciences.

THE Department of Agriculture has obtained from Peru samples of a giant species of maize. The size of the grains is four times as large as those of the species grown in the United States. The plant is very prolific and it is hoped that it will be possible to introduce it into America. Professor E. L. Sturtevant is making a study of this cereal, to which the name of '*Zea amylacea*' has been given, with a view to finding out how it may be cultivated most advantageously.

EXTENSIVE studies of the upper atmosphere have been planned by Professor A. McAdie, of the Weather Bureau, by the means of flying kites. Ten kites, the two leaders measuring six feet high by seven wide and eight others following five feet high by six feet wide, will be flown, if possible, to the height of two miles. It is hoped, by the means of these experiments and others which will follow them, to make possible the drawing of a map of the atmosphere in which temperature and barometric curves, electric currents, etc., will be located for various parts of the country and for different seasons of the year. The kites will be kept in the air twelve hours, if possible. In order that accurate temperature

curves may be taken, a registering thermometer will be attached near the top of line. A surveyor's transit will be used to calculate the height to which the kites ascend, the differences being worked out by triangulation.

THE Third International Congress of Agriculture will be held at Brussels from September 8th to 16th.

AN International Exhibition of Hygiene, organized under the direction of M. Brouardel, was opened at Paris on Thursday last. The exhibits are divided into five groups, referring respectively to (1) the hygiene of private houses; (2) city hygiene; (3) the prophylactics of zymotic diseases, demography, sanitary statistics, etc.; (4) the hygiene of childhood, including alimentary hygiene, questions of clothing and physical exercises; (5) industrial and professional hygiene.—*Nature*.

A RETURN has been issued showing the number of experiments performed on living animals in 1894 under licenses, as required in Great Britain. The total number of persons holding licenses during the year was 185, and of these 56 performed no experiments. 3104 experiments were performed in all.

THE second Italian Geographical Congress will be held in Rome during the latter part of September, 1895, the days not yet having been designated. Information concerning the Congress, which is held under the patronage of the King of Italy and promises to be one of great importance, can be obtained from the President of the committee, Via del Plebiscito 102, Rome.

THE Academy of Sciences of Prague has begun the publication of a *Bulletin Internationale*.

THERE remains in the treasury of the city of Baltimore about \$280,000 left from the fund of \$1,000,000 obtained by the issue of city bonds for the purpose of completing

the purchase of Clifton Park from the Johns Hopkins estate. It is proposed to use this money in the construction of a Boulevard from Druid Hill Park to Clifton Park.

PROFESSOR SIKORSKI, of the University of Kief, writing in the *Kievianin* upon the psychology of the Russian people, brings forward some interesting statistics concerning the frequency of suicide in the different nations of Europe. According to these figures the death-rate from suicide per million living is in Saxony 311, in France 210, in Prussia 133, in Austria 130, in Bavaria 90, in England 66, while in Russia it is as low as 30. Further, it is found that during the last thirty years the suicide-rate has in Russia remained stationary, while in all other European countries it has increased by 30 or 40 per cent. The exact significance of figures such as these, relating to so complex a phenomenon, as suicide, is not easily brought out. Few, however, will be disposed to question the assertion that much of the explanation of the low rate in Russia is to be found in the patience and long suffering of the Russian peasant under even the worst misfortunes. Among other characteristics Professor Sikorski also finds a certain indecision of character which fears to say a word or do an action which shall not admit of retreat or withdrawal. Crime is comparatively rare in Russia; thus, the number of persons tried for murder per million living in the year 1887 was in Italy 96, in Spain 55, in Austria 22, in France 14, in Russia 10, in Germany 9, and in England only 6.—*The Lancet*.

AT the annual meeting of the American Institute of Electrical Engineers Professor F. B. Crocker presented a preliminary report from the committee on indexing electrical literature. The committee reported that it was very desirable for the Institute to undertake a complete index of electrical literature, and that the past, rather than

current, literature should be cared for first as being the more important. The expense of this undertaking would be from \$16,000 to \$30,000. The committee believed that the index should include brief notes as to the character or scope of articles, since a single line of description would save the looking up of probably seven-eighths of the possible references.

IN *The Atlantic Monthly* for August Mr. Percival Lowell concludes his series of articles on Mars treating the 'oases.' He reviews the evidence on which he finds it probable that we see the effects of local intelligence on the surface of the planet as follows: "We find, in the first place, that the broad physical conditions of the planet are not antagonistic to some form of life; secondly, that there is an apparent dearth of water upon the planet's surface, and, therefore, if beings of sufficient intelligence inhabited it, they would have to resort to irrigation to support life; thirdly, that there turns out to be a network of markings covering the disc precisely counterparting what a system of irrigation would look like; and, lastly, that there is a set of spots placed where we should expect to find the lands thus artificially fertilized, and behaving as such constructed oases should."

DR. D. W. MCGEE, lecturer in Oriental literature in Toronto University, was drowned on July 22d.

DR. ERNEST HENRI BAILLON, the well-known naturalist, died recently in Paris at the age of seventy-two. He was professor of medical botany in the School of Medicine, and of hygiene in the Central School of Arts and Manufactures. He was the author of a number of books on botanical subjects.

PROFESSOR CHARLES C. BABINGTON, professor of botany in Cambridge University, died in Cambridge on July 22d, at the age 87 years.

DR. NORTON S. TOWNSHEND, professor of agriculture in the State University of Ohio, died recently at the age of seventy-nine. He was a student of medicine and graduated in New York in 1840. In 1863 he was appointed medical inspector in the United States army, in which capacity he served until the end of the war. In 1869 he accepted the professorship of agriculture in Iowa Agriculture College, of which he was one of the founders. He resigned a year later to assist in founding the Agricultural and Mechanical College of Ohio, in which institution, now known as the University of Ohio, he held the chair of agriculture from 1873 to the time of his retirement as professor emeritus.

PROFESSOR JULIUS ZUPITZA, the celebrated philologist, died recently in Berlin at the age of 51. He held the chair of English in Berlin University for nineteen years.

UNIVERSITY AND EDUCATIONAL NEWS.

THE Board of Trustees of the City of New York have selected a site for the new College Building on Covent Hill. It consists of 127 city lots bound north by 138th street, south by 140th street, east by St. Nicholas avenue and west by Amsterdam avenue. The appropriation for the site is limited to \$600,000, but it is believed that the price of this land will come within the required limits.

THE accommodation of Radcliffe College has been enlarged by the purchase of a new house.

THE trustees of the estate of the late Miss Margaret Harris have given securities valued at £14,000 and yielding about £470 to establish a chair of physics in the Dundee University College.

IT is proposed to establish an economic museum in the University of Pennsylvania. The museum will contain samples of the products and materials of all the arts, in-

dustries and trades of productive, technical and constructive industry.

It is stated that Dr. Francis Walker has accepted a call to the department of political and social science in Colorado College.

THE University of Pennsylvania extends the right of naming one of the houses in the new dormitory to all contributors of \$10,000 or more to the building fund. The following are the names of the contributors up to the present date: Charles C. Harrison, Alfred C. Harrison, Thomas F. Dolan, Robert E. Foerderer, William M. Singerly, Hugh Craig, Jr., Alice D. Craig, Hatfield, Burnham, Williams & Co., the Misses Blanchard, Thomas McKean, E. H. Fidler, J. E. Bayard, Richard F. Loper and William W. Frazier.

CORRESPONDENCE.

ABORIGINAL SANDALS.

DEAR SCIENCE: In attempting to comprehend the practical part of drawings, etchings, carvings and sculptures in the mountain region of America from Mexico southward, I have often tried to get some information of the footwear. Any one who will look through the drawings of 'Kingsborough' will notice that the sandals on the feet of the different figures have soles and heelstraps looking almost like the quarters of a modern shoe or the heel of a Peruvian soldier's sandal, and that in some way a lacing passes around in front of the ankle on top of the foot. There is no intimation of a string or strap passing up between the toes as in the modern rawhide sandal, which may be seen by the thousands on the feet of peons in Latin America all the way from Arizona and New Mexico to the limits of Peru.

Wiener, in his work entitled 'Perou et Bolivie,' figures a great many styles of these modern sandals which are, in form, allied to the thousand-and-one varieties in use anywhere about the Mediterranean, and

awakens a suspicion that the sandal with a single string passing between the great toe and the second toe is of Eurafian origin.

In plate (3) of 'Stone Sculptures of Copan and Quirigua, with drawings by H. Meye and text by Julius Schmidt, published in New York in 1883 by Dodd & Mead,' there will be seen on the foot of the Monolith a sandal in which a string passes between the first and the second toe and the third and the fourth toe, forming a loop which is attached by means of a knot to an ornamental bandage encircling the ankle, and it is to this sculpture that I wish to draw special attention.

Those of my readers who were so fortunate as to visit the Cliff-dweller collections at the Columbian Exposition may recall the styles of sandals there exhibited; if not, they will please turn to 'Nordenskjold's' illustrated work on the Cliff-dwellers' collections, made by him, and examine plate (46). There two styles of sandals are figured, not very distinctly, but the characteristics can be made out.

I am indebted, however, to Mr. Stewart Culin, of Philadelphia, for the privilege of examining carefully four examples of Cliff-dwellers' sandals in possession of the Museum of the University of Pennsylvania. In three of these there is either a loop or a provision for a loop, which passes between the first and the second toe and the third and the fourth, enclosing the second and third toe. In the fourth sandal a series of loops around the margin of the sole serve to receive the lacing which passes backward and forward, across the foot diagonally through one and then another, using up the whole series. These four sandals will now be more carefully described. In one of them the binding string or lacing commences at the instep and passes in a bend around the toe-loop, and by another bend around the right side of the heel-

cord, and by another bend around the left side of the heelcord and back to the starting point, where it is fastened off by a series of half-hitches. The heelcord is a twine woven into the margin of the sole on either side of the heel. This, according to Mr. Cushing, is called by the Zuñi *Égati* (heel-skin-under-grass). The sole is made of split *Yucca angustifolium* fibre plaited in the diagonal form of weaving common in the Pueblo country, each stitch passing over two and under two.

A second pair, having the eyelets worked in for the toeloop, is built upon a warp of twenty-three filaments or small bundles of shredded *Yucca* fibre. The weft is doubled, the upper portion consisting of a close weaving exactly like that on the Pueblo blankets and belts, the yarn being twisted bast fibre (probably *Apocynum*). The lower part of the sole consists of a series of rows or twined weaving laid under and enclosed in the warp of the upper weaving, but not appearing on the upper side. The exact technique of this under weaving has not been made out, owing to the danger of mutilating the specimen, but it seems to be in a line with the composite texture noticed in the Yoki baskets which I have described elsewhere. This sandal, when new, was prettily decorated with bands and stripes of red and black threads, alternating with the natural color of the material. At the heel and toe the warp threads are braided down and enclosed in an ornamental border of plaited buckskin thong. The toestraps are missing and the heelstrap is a small rope of bast fibre. One end firmly secured, the other slips through a loop on the back and is used as a part of the lacing.

The third specimen is built up upon four warp ropes of shredded *Yucca* fibre; the weft being of short pieces of very loosely twisted yarn of *Yucca* fibre woven into the warp by the same style of weaving as in the last named, such as is seen on the blankets and

the Moki wicker trays and in the ordinary twilled goods. These short warp strands are so manipulated that the frayed ends shall be spread out on the top of the sandal. The four-stranded warp, the plan of weaving and the shredding of the ends, are precisely like the texture of many hundreds of Japanese and Corean sandals, only in this specimen the shredding forms the top of the sandal, while in the Japanese example of straw the shredding forms the bottom. The loop for the toes in this specimen is well shown, consisting of a bit of four-ply rope of the *Agave* fibre, loosely twisted. The lacing is gone.

The fourth example is a very coarse sole of split *Yucca* fibre plaited diagonally and plainly with loops of the same material around the margin for the lacing, and on top between the sole and the lacing is laid a pad or bed of neatly folded corn husks to act as a protection to the sole of the foot.

In the National Museum is a sandal woven in the same manner as the one last described, having a loop to enclose the second and the third toe. This specimen was dug from the celebrated mound in Saint Georges, Utah, by Edward Palmer.

If one will examine a collection of photographs showing the peon and common people of Mexico and other Latin American states by the Rev. F. H. Cleveland, he will notice that many are wearing sandals having no string between the toes whatever.

In the sculpture from 'Copan' and the mound at Saint Georges, we have the two ends of a geographic era in which the sandal has a loop in front enclosing two toes.

The questions raised by these specimens are as follows: Was the old aboriginal Mexican sandal provided with a loop to enclose the second and the third toe? Is the form of rawhide sandal, now so common in Latin America, having a single string between the first and the second toe, a derivative from the Old World?

The sandal with the loops around the edges may be compared with a specimen figured in 'Wiener's Peru,' made of hide fitted around the foot and slashed around the border to receive the lacing.

It may be also compared with sandals of vegetal material in collections from northern Japan and the Aino country.

Yours truly, O. T. MASON.
U. S. NATIONAL MUSEUM.

THE PIGNUTS.

THERE is some question as to the exact distribution of the common Pignut (*Carya porcina* or *Hicoria glabra*) and the related *Carya* or *Hicoria microcarpa*, and the undersigned will be grateful for herbarium specimens, and especially nuts with their husks, representing both. In the recently published seventh volume of Professor Sargent's *Silva*, the range of *glabra* is given as southern Maine to southern Ontario, through southern Michigan to southeastern Nebraska, southward to the shores of the Indian River and Peace Creek in Florida, and to southern Alabama and Mississippi, through Missouri and Arkansas to eastern Kansas and the Indian Territory, and to the valley of the Nueces River in Texas. *H. microcarpa* (treated in the *Silva* as a variety of *glabra*, under the varietal name *odorata*) is said to occur in eastern Massachusetts, Connecticut, eastern and central New York, eastern Pennsylvania, Delaware, the District of Columbia, central Michigan, southern Indiana and Illinois, and Missouri.

WILLIAM TREELISE.

ST. LOUIS, MO.

SCIENTIFIC LITERATURE.

A Students' Text-book of Botany: By SIDNEY H. VINES, Sherardian Professor of Botany in the University of Oxford. First half pp. x., 1-430, Fig. 279. 1894. Second half pp. xvi., 431-821. 1895. London, Swan, Sonnenschein & Co. New York, Macmillan & Co. 8vo.

The completion of this, the best general text-book of botanical science yet published in any language, and just now the only adequate presentation in compact form of the subject-matter within its scope, is an event of more than ordinary interest in the annals of book-making. It is not too much to say that in this work Dr. Vines has surpassed even the high expectations of his friends. The volumes in hand have all the admirable literary quality and firm grasp of recent research that characterized so notably the *Lectures on the Physiology of Plants* by the same author, which appeared in 1886 and immediately took its place among the leading authoritative manuals in its line. The later work gains, perhaps, over the earlier in its somewhat more concise and transparent style and in its more perfect subjection of the material to the logical classification adopted at the outset. Certainly nothing could be better than the chapters on the general morphology of the members, on the tissues and on the general physiology. It is a great gain to botanical teaching in England and America to have the modern point of view in anatomy and physiology thus brought forward without the confusion and archaisms that diminished in a degree the availability of older texts in common use.

In general, it should be said that the perspective of the work is most admirable. About the right relative amount of space is given to each of the four principal subdivisions—Morphology, Anatomy, Taxonomy (here called *angliè*, the 'Classification of plants') and Physiology. As has been pointed out by previous reviewers, it might seem that the third division has been somewhat unduly extended at the expense of the fourth. Doubtless this is a natural result of Dr. Vines having specialized in physiology, for under such conditions he would possibly desire to err rather on the side of understating than of overstating the prom-

inance of his particular field, and again, in a department of the subject where his investigations and research have been so voluminous, it might seem to him a more hopeless task than elsewhere to present more than an abstract within the limits he had decided upon.

A point of peculiar excellence in this work is the terminology. Indeed, the reviewer has but one complaint to make, and that is that a somewhat too wide implication is permitted to the term 'spore.' It would seem advisable upon theoretical as well as upon practical grounds to limit zygotes, oöspores or oöspersms under another name, which should indicate their sexual origin. But the conservatism apparent in Dr. Vines' use of 'spore' in the general sense is more than atoned for by his splendid development of the Schwendener-Van Tiéghem terminology of the vascular and stelic tracts, by his masterly treatment of conjunctive and cortical tissue, by his illuminating explanation of secondary increase in thickness and in the special portion by his thorough and adequate separation of sporophytic from gametophytic terminology. This latter becomes a trifle less perfect in handling when the angiosperms are taken up, but even here, if one makes a slight mental alteration in the sequences, there is no trouble in gaining an accurate idea of the homologies. For an exactly logical presentation of life-histories, it is not clear that Dr. Vines would not have served his purposes as well by always discussing the gametophyte in detail before passing to the sporophyte. In point of fact, the gametophyte is given prior treatment until the Pteridophytes are reached, and then, in the ascending order, the sporophyte is given its handling before the gametophyte. This is, of course, in deference, perhaps unconscious, to the ancient notion that the larger or more potent in vegetation of the two alternating forms is *the plant*, while the other is to a degree sub-

sidary. It is not apparent that it would not on the whole have been better to give the phylogenetically older gametophyte its proper precedence in all cases from Oedogonium to Angiospermae.

The wealth of terminology has by some unthinking reviewers been condemned as making the whole work unnecessarily technical in tone and even giving a flavor of pedantry to the whole. In reply to such criticisms, Dr. Vines might aptly point out that a certain class of botanical textbooks which inform one that the 'spores are the seeds of the fungi,' for example, follow this valuable rule of calling fundamentally different things by the same name. In such cases the terminology is simple, and so is the state of mind of the student who has followed it. Modern botany is scarcely the young person's discipline of floral delectation that it was earlier supposed to be, and it does no harm to have a clear, clean-cut, limitation of different concepts under different names.

In the taxonomic portion of the work there is a conservative tone about the angiosperm arrangement which betokens the persistence of the great influence of Robert Brown, Lindley and Bentham. This is in interesting contradistinction to the firm touch with which the author places Isoëtes in its proper place alongside of Marattia and to his modern grouping of algæ, fungi and bryophytes. It should be taken as evidence, it may be, of the timidity with which the serious student of morphology approaches the antiquated delusions of systematic botanists which, more than any other delusions of botanical science, are embalmed in sumptuous volumes, under the ægis of powerful reputations and upon the foundations of scientific officialism. The cryptogams, so-called, are recognized to be a more modern and plastic group—from the point of view of investigation. Hence, one who trusts to his own good judgment and to the van-

guard of current research when cryptogamic morphology or taxonomy is in question may lean a little on the established order when he sets foot among the angiosperms. While Dr. Vines' treatment of angiospermic taxonomy does not, on the whole, please the reviewer as well as that of Warming or Schimper or of the Engler-Prantl series, nevertheless this is a matter largely of individual opinion.

In conclusion, the Vines text-book is a remarkably strong and well-balanced work. Its peculiar excellences are in the generally modern point-of-view, the transparency of the style, the perfection of the terminology, the firm and logical grouping of the material, the compactness of the treatment—especially in the chapter on physiology—the introduction of exact morphological conceptions to take the place of vague, and the evidence of wide and painstaking research that appears upon almost every page. Students of botany are to be congratulated in the same breath with the author upon the completion of the book.

CONWAY MACMILLAN.

UNIVERSITY OF MINNESOTA.

Chemical Analysis of Oils, Fats, Waxes and of the Commercial Products Derived Therefrom.

From the German of PROFESSOR DR. R. BENEDIKT. Revised and enlarged by DR. J. LEWKOWITSCH., F. I. C., F. C. S., Technical Manager at the Whitehall Soap Works, Leeds, England. Macmillan & Co., New York, publishers. Price, \$7.00.

The threefold task of translating, revising and enlarging Dr. Benedikt's work 'Die Analyse der Fette und Wachsarten, 1892,' by Dr. Lewkowitsch has resulted in presenting those interested in the subject the best and most complete work on Fats, Oils and Waxes. It is rarely that one finds the work of the translator so excellently performed. Almost every page bears

the evidence of additions and alterations. The little work of the first publication of Dr. Benedikt has now grown into a large volume of almost 700 pages, an evidence of the numerous researches that have been made in this subject. Much of the work that we are accustomed to see in older works is here omitted, and we find it replaced by the results of more modern thought. We cannot accuse Dr. Lewkowitsch of publishing the work from other books, for at the end of almost every chapter the writer gives his experience with the various methods proposed and advises which one should be accepted, showing that this work is the result of many years' investigation. This method is most gratifying to the chemist, for assisted by the advice of such an authority much otherwise needlessly wasted time is saved.

The chapter on Physical and Chemical Properties of Fats and Waxes is very complete. Who is it who will not be thankful to Dr. Lewkowitsch for giving us concisely the result of the many publications on the rancidity of fats? "Rancidity (says Dr. L.) must, therefore, be considered due to direct oxidation by the oxygen of the air, this action being intensified by exposure to light." The table on p. 50 giving the percentages of free fatty acids in oils and fats of vegetable origin is new and is of special interest. Some of the oils, when freshly pressed from the seed, present so small a percentage that we may assume that these fats as well as the animal fats originally exist as absolutely neutral glycerides. Almost all works on fats and oils—as does this one—assert that "Fats can be heated to 250° C without undergoing any change." This I think most men who handle fats and oils practically will be forced to deny. No matter how carefully the fat has been refined to free it from all foreign matter, after being subjected to such heat it no longer possesses its original physical properties.

Lard or tallow will assume the appearance of a soft grease.

The part of the work devoted to the Quantitative Analysis is excellently written, disclosing at once that the author is thoroughly familiar with the work. The latest researches are carefully quoted and criticised, the criticisms being usually strengthened by results obtained in his own laboratory. We refer the reader especially to Twitchell's method for the determination of Resin Acids. On p. 196 he says: "Of all the methods proposed hitherto for the estimation of resin acids in mixture with fatty acids, that recommended by Twitchell yields the best results, and should therefore be used to the exclusion of the methods described before. The results, however, must not be considered as absolutely correct; they are only approximate, as Lewkowitsch has shown by an exhaustive examination of both the volumetric and gravimetric processes." The author then gives a series of tables giving the results of this work. Dr. Lewkowitsch's assumption that the reason for the results by this process, being only approximate, is due to the action of hydrochloric acid upon the resin, has since the publication of this work been shown to be wrong. Evans and Beach in a recent publication have shown that the low results obtained by the gravimetric process is due to a large percentage of unsaponifiable matter in the resin. They found as high as 9 per cent. of unsaponifiable matter in one resin.

The Chapters IX., X., XI. and XII. are almost entirely rewritten and contain much original work. The sulphur chloride test for drying oils offers many interesting points of inquiry. In the table given on p. 228 we find that tallow and lard do not thicken with $S_2 Cl_2$, and that the resulting product is entirely soluble in carbon bisulphide, whereas on p. 229 we find in another table that tallow oil and lard oil (products obtained by pressure from tallow and lard)

solidify with $S_2 Cl_2$ after 12 and 10 minutes respectively and form products not completely soluble in carbon bisulphide. In summing up the results of the various investigations on 'Color Reactions,' Dr. Lewkowitsch said that the results on all color reactions should be taken with the greatest caution and mention should be made that the test for cotton seed oil with nitric acid which the author so forcibly recommends be included. The descriptions of the various oils, fats and waxes are very complete. The part given to cotton seed oil is especially so. In this one description we find twenty-three different publications referred to, including articles from American, English, German, French and Italian journals.

We are very sorry to find Dr. Lewkowitsch follows the footsteps of so many European chemists, decrying everything foreign. We should be pleased to know his authority for the following: (p. 460) 'in America adulteration has become an openly acknowledged practice,' etc. It simply points out to the American reader the customary ignorance of foreigners regarding our laws on the subject of adulteration. In Chapter XII., devoted to Technical and Commercial Analysis, lard and lard substitutes are dismissed with two and one-half lines. It is upon this very subject that a well directed system of investigations is necessary, and to judge by the numerous cases of supposed adulterations at all times before the English courts, Dr. Lewkowitsch's works would be considered the better for it, and must be considered incomplete for the lack of it.

JOSEPH P. GRABFIELD.

CHICAGO, July 6, 1895.

SCIENTIFIC JOURNALS.

AMERICAN JOURNAL OF SCIENCE.

THE August number of the *American Journal of Science* opens with an article by

Frank H. Bigelow upon the 'Earth as a Magnetic Shell.' This is an investigation, largely theoretical, upon lines already followed by the author in earlier publications. In discussing the modes of transference of energy from the sun to the earth, he assumes, in addition to the electro-magnetic radiation emanating from the sun in all directions in straight lines, also a magnetic radiation belonging to the 'magnetic field,' which near to the earth is at right angles to the ecliptic. In this magnetic radiation are found the explanation of several sets of phenomena, as the aurora, magnetic disturbances, earth currents and meteorological periodic variations. This subject is discussed at length with the aid of a number of diagrams. The author concludes from the values obtained for the vectors of the polar magnetic field at the earth that there is an *expected* system around the poles and an *inflected* system in the tropical belts. Further, he shows that the outer stratum, or shell, of the earth is permeable to external magnetic forces, while the nucleus is not; assuming that $\mu=2$, the radius of the nucleus is calculated to be 3170 miles. The effect of the magnetic radiation argued for is discussed with reference to the several sets of phenomena mentioned, and it is also suggested that certain deviations from the Newtonian law of gravitation noted in the secular motions of the sun and the planets may find their explanation in a mechanical stress called out by this 'magnetic radiation.' Another physical article is by J. Trowbridge and W. Duane, who continue their discussion of the results obtained in the Jefferson Physical Laboratory in the experimental determination of the velocity of electric waves. The essential features of the methods employed have been earlier (April, 1895) described, but they are here improved upon. The final result for the velocity obtained is 3.0024×10^{10} , and the conclusion is reached that the velocity of

short electric waves traveling along two parallel wires differs from the velocity of light by less than two per cent. L. A. Bauer takes up anew the discussion of the distribution and secular variation of terrestrial magnetism—a subject treated by him in the thesis noticed in SCIENCE, Vol. I., No. 25—and reaches some important results to be extended in a following article; they may be more definitely spoken of later in connection with this. Two articles upon analytical chemistry come from the laboratory of F. A. Gooch at New Haven; the first, by Gooch and Phelps, is a discussion of a new method of determining carbon dioxide; the second, by Kreider, describes some new devices (as a hot filter, a valve, etc.) convenient in the laboratory. In the department of mineralogy, W. M. Foote describes leadhillite pseudomorphs from Granby, Mo.; W. H. Hobbs describes cerussite crystals from Missoula, Montana, barite and manganite from Negaunee, Michigan, chloritoid from Michigamme, Mich.; W. F. Hillebrand gives analyses of calaverite from Cripple Creek, Colorado. In petrology, L. V. Pirsson discusses the subject of complementary rocks and radial dikes. In the department of botany, B. L. Robinson and J. M. Greenman present a long article (42 pages, forming contribution No. IX., N. S.), from the Gray Herbarium, and containing descriptions of many new species. This consists of four parts, viz.: I. On the Flora of the Galápagos Islands, as shown by the collection of Dr. G. Baur; II. New and Noteworthy Plants, chiefly from Oaxaca, collected by Messrs. C. G. Pringle, L. C. Smith and E. W. Nelson; III. A Synoptic Revision of the Genus *Lamourouxia*; IV. Miscellaneous New Species. The number (108 pages) concludes with a notice of Professor Thomas H. Huxley by O. C. Marsh, and likewise one of Professor Daniel C. Eaton by W. H. Brewer.

SCIENCE

NEW SERIES.
VOL. II. No. 32.

FRIDAY, AUGUST 9, 1895.

SINGLE COPIES, 15 CTS.
ANNUAL SUBSCRIPTION, \$5.00.

GUSTAV E. STECHERT'S Recent Importation of Scientific Books.

BECKERT, TH. and DR. ALBANO BRAND. Hüttenkunde. Mit 235 in den Text gedruckten Figuren. 765 Seiten. gr. 8°. Mk. 20.

BEHRENS, H. Anleitung zur mikrochemischen Analyse. Mit einem Vorwort von Prof. S. Hoogewerf in Delft. 224 Seiten mit 92 Figuren in Text. 8°. Mk. 6.

BIEDERMANN, W. Elektrophysiologie. 1^{te} Abtheilung. Mit 136 Abbildungen. 440 Seiten. 8°. Mk. 9.

BORCHERS, DR. W. Elektro-Metallurgie. Die Gewinnung der Metalle unter Vermittlung des elektrischen Stromes. 2^{te} verm. v. völlig umgearb. Auflage. 1^{ste} Abtheilung, mit 87 Abbildungen. 100 Seiten. gr. 8°. Mk. 6⁰⁰.

BUSCHAN, GEORG. Vorgeschichtliche Botanik der Cultur- u. Nutzpflanzen der alten Welt auf Grund prähistorischer Funde. 268 Seiten. 8°. Mk. 7⁰⁰.

DAMMER, DR. O. Handbuch der chemischen Technologie. Unter Mitwirkung von Direktor Th. Beckert, Dr. Bender, Dr. Benedikt, Dr. Eörnstein u. A. herausgegeben. 2^{ter} Band. Mit 235 in den Text gedruckten Figuren. gr. 8°. Mk. 20.

DELAGE, YVES. La structure du protoplasma et les théories sur l'hérédité et les grands problèmes de la biologie générale. 878 pages. gr. 8° cloth. frs 24⁰⁰.

DETMER, DR. W. Das pflanzenphysiologische Praktikum. Anleitung zu pflanzenphysiolog. Untersuchungen für Studierende u. Lehrer der Naturwissenschaften, sowie der Medicin, etc. 2^{te} völlig neubearbeitete Aufl. Mit 184 Abbildungen. 456 Seiten. 8°. Mk. 9.

FOREL, DR. AUGUST. Der Hypnotismus, seine psycho-psychologische medicinische, strafrechtliche Bedeutung und seine Handhabung. 3^{te} verm. Aufl. mit Adnotationen von Dr. O. Vogt. 223 Seiten. gr. 8°. Mk. 5.

FRANK, DR. A. B. Die Krankheiten der Pflanzen. Ein Handbuch für Land u. Forstwirte, Botaniker, etc. Erster Band, Die durch anorgan. Einflüsse hervorgerufene Krankheiten. Mit 34 Holzschnitten. 2^{te} Aufl. 344 Seiten. 8°. Mk. 6⁰⁰.

HIS, WILH. Die anatomische Nomenclatur. Nomina anatomica, Verzeichniss der von der anatomischen Gesellschaft auf ihrer 9. Versammlung in Basel angenommenen Namen. Mit 30 Abbildgn. im Text und 2 Tafeln. 180 Seiten. Mk. 7⁰⁰.

HOUDALLE, F. Météorologie agricole. 204 pages cloth. fr. 3.

JAHRBUCH DER ELEKTROCHEMIE. Berichte über die Fortschritte des Jahres 1894. Im wissenschaftlichen Theile bearbeitet von Dr. W. Nerst. Im technischen Theile bearbeitet von Dr. W. Borchers. 1^r Jahrgang. 274 Seiten. gr. 8°. Mk. 10.

JERUSALEM, WILH. Die Urtheilsfunction. Eine psychologische und erkenntniskritische Untersuchung. 269 Seiten. Mk. 6⁰⁰.

LOEVI, DR. A. Untersuchungen über die Respiration and Circulation bei Aenderung des Druckes und des Sauerstoffgehaltes der Luft. Mit 5 Curventafeln im Text. 155 Seiten. gr. 8°. Mk. 4.

MEYER, DR. ARTH. Untersuchungen über die Stärkekörner der höheren Pflanzen. Mit 9 Tafeln u. 99 Text-Abbildgn. 318 Seiten. gr. 8°. Mk. 20⁰⁰.

NIEDENZU, DR. FRANZ. Handbuch für botanische Bestimmungsübungen. Mit 15 Figuren im Text. 351 Seiten. 8°. Mk. 4.

SCHAFFER, DR. KARL. Suggestion und Reflex. Eine Critisch-experimentelle Studie über die Reflexphänomene des Hypnotismus. Mit 6 Tafeln in Lichtdruck und 11 Abbildungen im Text. 113 Seiten. gr. 8°. Mk. 6⁵⁰.

SCHMIDT, DR. ALEX. Weitere Beiträge zur Blutlehre. Nach des Verfassers Tode herausgegeben. 247 Seiten. 8°. Mk. 7.

SCHWARTZE, TH. Die Lehre von der Electricität und deren praktische Verwendung. Mit 153 in den Text gedruckten Abbildungen. 543 Seiten. 8°. Mk. 10⁰⁰.

STEINHARDT, DR. EUGEN. Kurzes Lehrbuch der Chemie zum Gebrauch an Schulen und zur Selbstbelehrung. Zwei Theile. Erst. Teil; Anorganische Chemie. 418 Seiten. 8°. Mk. 6⁰⁰.

VAN BIERVLIET, J. J. Elements de psychologie humaine. Cours professé a l'université de Gand. Avec 34 figures dans le Text. 317 pages. frs. 8.

ZEITSCHRIFT FÜR ANGEWANDTE MIKROSKOPIE herausgegeben von G. Marpmann. Monthly. 1^{er} Band 1^{tes} Heft. Per year, \$2.75.

ZEITSCHRIFT, Geographische, Herausgegeben von Dr. Alfred Hettner. 1^{er} Jahrg. 1^{er} Heft. Per year (12 N^{os}) \$4⁰⁰.

ZIMMERMANN, DR. A. Das Mikroskop. Ein Leitfaden der wissenschaftlichen Mikroskopie. Mit 231 Figuren im Text. 334 Seiten. gr. 8°. Mk. 9.

ZITTEL, KARL A. VON. Grundzüge der Paläontologie (Paläozoologie). Mit 2048 in den Text gedruckten Abbildungen. 971 Seiten. gr. 8°. ½ mor. Mk. 25⁰⁰.

GUSTAV E. STECHERT,

810 Broadway, New York.

Macmillan & Co.'s New Publications.

The Cell: Outlines of General Anatomy and Physiology.

By DR. OSCAR HERTWIG, Professor Extraordinarius of Anatomy and Comparative Anatomy, Director of the II. Anatomical Institute of the University of Berlin. Translated by M. CAMPBELL and Edited by HENRY JOHNSTONE CAMPBELL, M. D., Assistant Physician to the City of London Hospital for the Diseases of the Chest, etc. With 165 Illustrations. 8vo, cloth, pp., \$3.00, *net*.

The American Commercial Policy.

Three Historical Essays. By UGO RABBENO, Professor of Political Economy in the University of Modena. Second Edition. Partly rewritten and entirely revised by the author. Translated at the Translations Bureau, London, W. C. 8vo, cloth, pp. 414, \$3.25, *net*.

Analytical Chemistry.

By N. MENSCHUTKIN, Professor in the University of St. Petersburg. Translated from the third German edition under the supervision of the Author. By JAMES LOCKE. 8vo, cloth, pp. xii+512, \$4.00, *net*.

The Great Frozen Land. Narrative of a Winter Journey Across the Tundras and a Sojourn Among the Samoyads.

By GEORGE F. JACKSON, Fellow of the Royal Geographical Society and Leader of the Jackson-Harmsworth Polar Expedition. With Illustrations and Maps. Edited from his Journals by ARTHUR MONTEFIORE. 8vo, cloth, pp. xviii+297, \$4.50.

Cambridge Natural Science Manuals.

A Text-Book of Zoögeography. By FRANK E. BEDDARD, M. A. (Oxon), F. R. S., Professor of the Zoölogical Society of London, and Lecturer on Biology at Guy's Hospital. 12mo, cloth, \$1.60, *net*. (*Biological Series.*)

Second Volume of the Century Science Series.

Edited by SIR HENRY E. ROSCOE, D. C. L., etc. (Biographies of Eminent Men of Science.)

Major Rennell, F. R. S., and the Rise of English Geography.

By CLEMENTS R. MARKHAM, C. B., F. R. S., President of the Royal Geographical Society. 12mo, cloth, \$1.25.

First Volume: John Dalton and the Rise of Modern Chemistry.

By SIR HENRY E. ROSCOE, F. R. S., etc. 16mo, cloth, \$1.25. Other volumes of this series in preparation.

The Horticulturist's Rule-Book.

A Compendium of Useful Information for Fruit-growers, Truck-gardeners, Florists and others. By L. H. BAILEY, Professor of Horticulture in Cornell University. Third Edition, thoroughly Revised and Recast, with many Additions. 12mo, limp cloth, 75 cents.

Short Studies in Nature Knowledge. An Introduction to the Science of Physiography.

By WILLIAM GEE, Certified Teacher of the Education Department and of the Science and Art Departments. Illustrated with 117 engravings, comprising portraits, views, etc. 12mo, cloth, \$1.10, *net*.

MACMILLAN & CO., 66 Fifth Avenue, New York.

SCIENCE

EDITORIAL COMMITTEE: S. NEWCOMB, Mathematics; R. S. WOODWARD, Mechanics; E. C. PICKERING, Astronomy; T. C. MENDENHALL, Physics; R. H. THURSTON, Engineering; IRA REMSEN, Chemistry; J. LE CONTE, Geology; W. M. DAVIS, Physiography; O. C. MARSH, Paleontology; W. K. BROOKS, Invertebrate Zoology; C. HART MERRIAM, Vertebrate Zoology; S. H. SCUDDER, Entomology; N. L. BRITTON, Botany; HENRY F. OSBORN, General Biology; H. P. BOWDITCH, Physiology; J. S. BILLINGS, Hygiene; J. MCKEEN CATTELL, Psychology; DANIEL G. BRINTON, J. W. POWELL, Anthropology.

FRIDAY, AUGUST 9, 1895.

CONTENTS:

| | |
|--|-----|
| <i>Saporta and Williamson and their work in Paleobotany</i> : LESTER F. WARD | 141 |
| <i>James C. Pilling</i> : W J MCGEE | 150 |
| <i>Agronomy in the Department of Agriculture</i> : F. LAMSON SCRIBNER | 151 |
| <i>Phototopography</i> : J. A. FLEMER..... | 152 |
| <i>The International Catalogue of Scientific Literature</i> | 154 |
| <i>Notes from London</i> : R. H. T. | 157 |
| <i>Scientific Notes and News</i> :— | 158 |
| <i>Fossil Mammals of Patagonia; Comparative Neurology; The American Microscopical Society; American Mathematical Society; The Helmholtz Memorial; General.</i> | |
| <i>University and Educational News</i> | 163 |
| <i>Correspondence</i> :— | 164 |
| <i>What is High Work?</i> L. H. BAILEY. | |
| <i>Scientific Literature</i> :— | 164 |
| <i>Lombroso's Female Offender</i> : CHARLES L. DANA. <i>Arendt's Chemie</i> : E. H. K. | |
| <i>Scientific Journals</i> | 167 |
| <i>The Botanical Gazette; The Psychological Review; Psyche.</i> | |
| <i>New Books</i> | 168 |

MSS. intended for publication and books, etc., intended for review should be sent to the responsible editor, Prof. J. McKeen Cattell, Garrison on Hudson, N. Y.
Subscriptions and advertisements should be sent to SCIENCE, 41 N. Queen St., Lancaster, Pa., or 41 East 49th St., New York.

SAPORTA AND WILLIAMSON AND THEIR WORK IN PALEOBOTANY.

THE science of fossil plants has lost within a period of less than six months two of its oldest and most eminent cultivators, the Marquis Gaston de Saporta and Professor William C. Williamson, the former of whom died on the 26th of January, at the age of

seventy-two years, and the latter on the 23d of June, at the age of seventy-eight years. The immense loss which science has sustained in the death of these two men is only partially lessened by the fact that they were not cut off, as are so many men of promise, in the prime of life, but were spared to continue to a ripe age their valuable labors. The monument that each has erected for himself is greater and more enduring than any that others can ever erect for them.

Having been in direct communication with both of them for a full decade and having been also, to a limited extent, personally acquainted with them, I have felt it a duty to science, and especially to that branch of science which I have cultivated most, to speak a word from this side of the Atlantic in recognition of their services.

THE MARQUIS SAPORTA.

In a paper in which I contributed in 1885 to the Fifth Annual Report of the U. S. Geological Survey (p. 383), and in which I gave brief sketches of the principal workers in paleobotany, I attempted to review Saporta's work, as then known to me, from an acquaintance with his scientific contributions. This sketch was exceedingly defective and did poor justice to his merits, but was the best I was able to make at that date. Aside from the grave omissions there made, it must be said that his labors were

far from being completed, and in the last ten years of his life he produced many of his most important works. It is not always safe to judge an author by the number of titles that his bibliography contains, but for an author all of whose contributions are certain to be of value to science this criterion has considerable weight. I have been able to collect together about 150 titles of Saporta's works, several of which are volumes elaborately illustrated, and two of which consist of long series of exhaustive and painstaking papers.

I shall attempt here to mention only a few of the leading subjects to which the Marquis Saporta devoted his energies. He was born at St. Zacharie, Department of Var, in the South of France, on the 28th of July, 1823, and christened Louis Charles Joseph Gaston. As his name indicates, he was of Spanish descent and belonged to one of the oldest families of the nobility of that country that are so frequently met with in this part of France. We are informed by his illustrious co-worker, M. R. Zeiller,* that he was in more or less direct communication during his boyhood with the eminent entomologist, Boyer de Fonscolombe, his maternal grandfather, and that his own father also cultivated entomology to some extent. This may have tended to inspire in him a taste at least for scientific study. But this atavistic taste did not develop in early life, and prior to the age of 30 he devoted himself chiefly to literature and history. At about that time he was accidentally brought into relations with the founder of paleobotany, M. Adolphe Brongniart, who had been interested in certain fossil plants from Tertiary beds near Saporta's home at Aix and from Manosque. This appears to have given the special bent to his mind which determined the labor of the rest of his life, and

thenceforward to the time of his death he devoted himself unceasingly to the study of fossil plants, and largely to those rich fossil floras which he has made known in Provence. A letter which he wrote to M. Charles Th. Gaudin, and which the latter published in the 6th volume of the 'Bulletin de la société Vaudoise des sciences naturelles' for April 18, 1860, shows clearly that he had already at that date been a long time engaged in the collection and study of the fossil plants of Provence, but this seems to have been his earliest contribution on the subject of fossil plants. These already rather full notes were greatly expanded and published the following year in Gaudin's translation of Heer's Researches on the 'Climate and Vegetation of the Tertiary,' which forms a part of the 3d volume of Heer's 'Tertiary Flora of Switzerland,' the French translation being published separately.*

These papers were merely preliminary to the extensive series which began to appear the next year, viz., his 'Études sur la végétation du sud-est de la France à l'époque tertiaire.' This series was published in the 'Annales des sciences naturelles, botanique,' beginning with the 16th volume of the 4th series, 1862, and concluding with the 9th volume of the 5th series, 1868, and embracing 13 distinct papers, all profusely illustrated by beautifully prepared lithographic plates. Four years later he made a complete revision of this work in three similar papers which appeared in the 15th, 17th and 18th volumes of the same serial, 1872-1873. In 1888 he returned to this subject and published his 'Dernières adjonctions' in two papers in the 7th and 10th volumes of the 7th series of the same work. In this exhaustive treatise the Tertiary flora of the

* Recherches sur le climat et la végétation du pays tertiaire, par Oswald Heer, traduction de Charles Th. Gaudin, Winterthur, 1861. B. Examen des flores tertiaires de Provence par M. Gaston de Saporta, pp. 133-171.

* Revue générale des sciences, 15 avril, Paris, 1895, p. 359.

South of France has been made as well known to science as is its living flora.

While in the midst of the studies of the Tertiary flora of southern France he undertook another even more ambitious work, being nothing less than a complete monograph of the Jurassic Flora of France to be published in the great paleontological serial, the 'Paléontologie Française.' This monumental work was issued in fascicles to the number of forty-seven, beginning in January, 1872, and ending in July, 1891. It was finally published in four large volumes, with an aggregate of over 2000 pages and 300 plates, royal octavo. It is a complete systematic treatise on the entire Jurassic Flora of France, from the Infraalias or Rhetic to the Purbeck, and like all Saporta's works, which differ in this respect from those of most paleobotanical authors, it is founded upon a most careful study of the living vegetation of the globe.

It seems almost incredible that in the midst of these great labors Saporta should have found time for anything else beyond a few minor contributions; but not only was the number of these latter large and their magnitude often considerable, but several of them rise to the dignity of important works. Among such are to be mentioned his classical memoir on the Fossil Flora of Sézanne,* at the extreme base of the Tertiary; the still more extended monograph of the 'Pliocene Flora of Meximieux, Department of Ain,' in which, however, Professor A. F. Marion, of the University of Montpellier, was associated with him; † a fine es-

say on the 'Flora of Gelinden'* in Belgium, a formation in the extreme Upper Cretaceous, which appeared in 1873, with a revision of the same † in 1878, in both of which, as in the one last mentioned, Professor Marion assisted him; the handsome volume which he published in 1879, entitled 'Le monde des plantes avant l'apparition de l'homme,' which is a popular account of the whole subject of fossil plants written in a lucid and fascinating style, and which is to-day the best popular work on the subject and was translated into German by Carl Vogt in 1881; a still larger work somewhat in the same line but much less popular, and in the preparation of which Professor Marion was again associated with him, viz., 'L'Évolution du règne végétal,' published in three volumes as one of the International Scientific Series, no English translation of which has appeared. The first volume of this work, published in 1881, relates to the Cryptogams, and the second and third, which appeared in 1883 and 1885, respectively, to the Phanerogams. This is the most successful attempt thus far made to trace the development of plants from its earliest beginnings to its latest forms by the aid of paleontology, and if it be true, as is generally admitted, that complete success in this attempt was not attained, it will nevertheless form the basis for all future researches in this line.

Another and very different task was undertaken when in 1882 he essayed to reply to the strictures of Dr. A. G. Nathorst on the nature of the supposed fossil algæ of the earliest rocks. To this controversy he has contributed two elaborate treatises, the

* *Prodrome d'une flore fossile des Travertins anciens de Sézanne.* Mém. Soc. Géol. de France, 2e Sér., Vol. VIII., Paris, 1868, pp. 287-438, pl. xxii.-xxxvi.

† *Recherches sur les végétaux fossiles de Meximieux,* par le Comte G. de Saporta et M. le Dr. A. F. Marion, précédées d'une introduction stratigraphique par M. Albert Falsan. Archives du Muséum d'Histoire naturelle de Lyon, Vol. I., Lyon, 1876, pp. 131-335, pl. xxi-xxxviii.

* *Essai sur l'état de la végétation à l'époque des marnes heersiennes de Gelinden,* par le Comte G. de Saporta et le docteur A. F. Marion. Mém. Cour. Acad. roy. Belgique, Vol. XXXVII., No. 6, Bruxelles, 1873.

† *Révision de la flore heersienne de Gelinden,* par le Comte G. de Saporta et le Dr. A. F. Marion. Op. cit., Vol. XLI., No. 3, Bruxelles, 1878.

first entitled: 'A propos des algues fossiles,' which appeared in 1882 in the form of an illustrated folio volume of 82 pages and 9 plates; and the second entitled: 'Les organismes problématiques des anciennes mers,' which is a slightly larger companion volume of 102 pages and 12 plates. This is not the place to discuss the question involved in these works, but no one denies that the Marquis Saporta has here brought forward the strongest evidence that the case will permit for the existence of vegetable remains at these remote periods.

A second popular and very useful work was his 'Origine paléontologique des arbres cultivés ou utilisés par l'homme,' a small octavo volume of 360 pages and numerous woodcuts, which appeared in 1888. This work evinces a wide acquaintance with the dendrology, not only of Europe but of the world, and is based mainly upon the author's profound knowledge of the Later Pliocene and Quaternary floras of France.

Without stopping to mention other works which have almost as much claim as the ones already treated, I will indulge in a final word relative to the work upon which our author was engaged at the time of his death. I allude to his studies in the Lower Cretaceous flora of Portugal. After the death of Oswald Heer, to whom the collections made by the Geological Survey of Portugal from the plant bearing Mesozoic beds of that country had been sent, and who had published one important contribution to the subject, these collections were sent to Saporta, and he had been engaged upon them, as time would permit, since 1886. In 1888 he published, in the 'Comptes Rendus,' a preliminary account of their nature, in which it appeared that there were now being found in the Portuguese beds below the Cenomanian certain dicotyledonous forms which greatly interested the Marquis, since this was by far the earliest appearance in Europe of that type of plant life;

although, as was well known to him, we have, in our Potomac flora of Virginia, deposits of still greater age containing such plants. The appearance of this and a still later similar paper on the same subject but without illustrations, taken in connection with the fact that I was at the time actively engaged in the study of the equivalent beds of this country, led to an interesting correspondence, which was kept up until the summer of 1894, when it was my good fortune to pay a visit to the veteran paleontologist at Aix for the purpose of examining the material in his hands with a view to a comparison of the Portuguese forms with those of the United States. My brief sojourn at Aix and at Fonscolombe, as the guest of the Marquis, afforded me the valued opportunity to add to my knowledge of him as a scientific man and a genial correspondent, a glimpse of his personal character, and to learn that along with those sterling attributes which are required to make a man of science there went the generous hospitality, the unaffected simplicity and the cordial affability that characterize the true nobleman. My reception on that occasion at the Château of Fonscolombe, his country residence, where I made the acquaintance of his interesting family, was of the warmest character; and my brief stay there was in the highest degree enjoyable.

I found that the first instalment of his work on the Portuguese Flora was almost ready to appear, but the material that had reached him since this volume went to press was considerable, and this I was also permitted to see. I need not here repeat the account which I have already given in these columns* of the scientific value of this visit and the general nature of the work under consideration. He promised to send me the new volume, together with a number of other works of his which I informed him I had

*SCIENCE, New Ser., Vol. 1, March 29, 1895, pp. 337-346.

not yet received, but they never came, as the hand that was to direct them was soon stricken and compelled to lay down the pen that had written so many volumes and the pencil that had done more than any other to embellish the science of fossil plants.

His last undertaking seems to have been a work on the fossil Nympheaceæ and two preliminary papers had already appeared in the 'Comptes Rendus.' He showed me a wonderful series of specimens and the inimitable drawings of them that he was making.

The question naturally arises: Upon whom is the mantle of this eminent investigator destined to fall? In addition to a large amount of posthumous work that is known to exist, much of which is probably nearly ready for publication, there are the large collections which have been sent to him from many sources and which are greatly in need of elaboration.

He left a large family, children and grandchildren, and at least two of his sons have grown to manhood, the eldest, Count Saporta, whose acquaintance I made, as well as that of the Countess, was the private secretary to the Comte de Paris, and even while I was there he had received a dispatch announcing that the Comte was dying at his place of exile in England, whither he had to repair immediately, and we traveled together to Marseilles. Another married son, the Viscount Antoine de Saporta, has made at least one important contribution to fossil plants, viz., a review of Nathorst's 'Fossil Flora of Japan,'* based on the original Swedish text before the appearance of the authorized French translation, which was regarded of sufficient moment to call forth a reply from the author†. He may have written still other papers which have not come to my notice. Whether this young

man is to follow in the footsteps of his father remains to be seen.

There are two features of Saporta's work which have not been mentioned, viz., attention to bibliographical matters and a tendency to philosophize. For the past ten years Saporta had been contributing most valuable summaries in the entire domain of vegetable paleontology, which were published in the 'Revue générale de botanique,' under the direction of M. Bonnier. Many of these amount to original contributions and include the description and illustration of new forms.

With regard to his philosophical tendencies it should be said that he allowed the logic of facts to influence his thoughts, and was, from the outset, a consistent exponent of the general doctrine of evolution and the special doctrine of plant development. In addition to the works above referred to, which directly bear upon this subject, and to the general treatment of it in his popular works, he has contributed quite a number of articles to the popular magazines, especially to the 'Revue des Deux Mondes,' which have afforded him an opportunity to strike out the broad outlines of a general philosophy. One of the most original of his rational conclusions, and one that is fully sustained by the facts, but almost completely ignored by all other writers, is that the most important subdivisions of the geological scale must be drawn at different points for plant development from those at which they are commonly drawn for animal development. For example, the Mesophytic age properly ends with the Jurassic instead of with the Cretaceous, while the Tertiary for fossil plants closes with the Miocene instead of with the Pliocene.

PROF. W. C. WILLIAMSON.

In my series of sketches of the leading paleobotanists,* referred to above, still * Fifth Annual Rept. U. S. Geol. Surv., 1885, p. 376.

* Ann. de Sci. Nat., Bot., 6th Ser., Vol. XV., 1883, pp. 149-167.

† Loc. cit., pp. 337-341.

greater injustice was done to Prof. Williamson than to Saporta. I was acquainted with his work at that time only from the great series of memoirs which he was publishing in the Philosophical Transactions, and which I was only able to consult in the ponderous volumes of that serial. I therefore limited myself almost exclusively to a mention of that work, 12 numbers of which had then appeared. The earliest paper relating to fossil plants with which I was then acquainted was dated 1842, and I therefore provisionally gave this date as the beginning of his work on fossil plants. I soon after collected titles, some of which go back to 1836,* but in a letter from him dated June 16th, 1886, thanking me for this poor mention of his name, he said: "Your only mistake is in starting me on my paleobotanical career in 1842, since I am the same W. C. Williamson, Jun., whose name you will find so frequently in the Fossil Flora of Lindley and Hutton. You will see that my labors began in 1833, so that I have now been in the field 56 years—a regular old stager." I was indeed aware that a 'Mr. William Williamson, Jun.,' had contributed to Lindley and Hutton's Fossil Flora a large number of notes and sketches, all of which had been used by those authors and gratefully acknowledged, and I suspected that this might have been the same Professor Williamson, but as these notes all referred to impressions of plants from the Oolite of Yorkshire, while his chief labors had been on the internal structure of Carboniferous plants, it was natural that I should doubt their identity. I am now happy to be able to correct his correction and show that his absolutely first contribution to that work was made in 1832 instead of 1833.†

*See the Proc. Geol. Soc., London, for Nov. 16, 1836, Vol. II., p. 429.

†The Fossil Flora of Great Britain by John Lindley and William Hutton, Vol. I., London, 1831-1833 (the first fascicle, pp. 1-48, pl. i.-xiv., was issued in

The same year in which I received the above mentioned letter there occurred a transaction, which, though trifling in itself, serves in an admirable way to illustrate Professor Williamson's personal character. Being very desirous to obtain the reprints of his memoirs 'On the Organization of the Fossil Plants of the Coal Measure,' from the Philosophical Transactions, as well as many other works relating to fossil plants, I had prepared an extensive list of such works, including this one, from a catalogue of Dulau & Co., Soho Square, London, and requested the Geological Survey to purchase the books. The invoice arrived substantially complete with the exception of Professor Williamson's work. Much time elapsed and the work did not come, further correspondence showing that it had not been possible to obtain it. I therefore wrote direct to Professor Williamson, begging him if possible to spare a set to Messrs. Dulau & Co., for our use in America. The very next steamer brought the full set direct to me without cost and another characteristic letter, from which I make the following extract:

"Your letter of October 28th has thrown light upon what appeared to me a queer affair. I received an application from Messrs. Dulau for a set of my memoirs; I replied that I had only three spare copies left, that I never had sold a copy and that I much preferred not doing so, since I had rather reserve them and give them to some 1841 and the second, pp. 49-166, pl. xv.-lix., in 1832. His first sketch, which was that of *Cyclopteris Beantii*; constitutes pl. xlv., and is described on pp. 127-129. It was found by his father, but a note signed by 'W. Williamson, Jun.,' on p. 127, shows that he had much to do with it, and although it is not stated that the sketch was made by him, there is every probability that it was. An examination of the entire work shows that he contributed no less than 30 of the species described in it, constituting nearly all from the Oolite of Yorkshire, and that in every case he not only furnished the specimen but an accurate drawing which the authors always used).

paleontologists that I knew would make good use of them. * * *

"I am so glad that you have written direct to me about the affair, because yours is precisely the sort of case that I contemplated in my letter to Dulau & Co. I will send the set of 12 memoirs to you and beg that you will accept them from me."

William Crawford Williamson was born November 24th, 1816, at Scarborough, in Yorkshire. We are fortunate in having a most admirable sketch of his life by Mr. Charles Bailey, F. L. S., published in the Manchester Scientific Student's Annual Report for 1886, which sets forth the principal facts in connection with his early life and also contains, as a frontispiece, an excellent portrait of him at that date. In this paper Mr. Bailey says:

"Circumstances had made Professor Williamson's father a gardener by profession, but nature had made him a geologist, and placed him in one of her most valuable domains, viz., on the Oölitic and Cretaceous rocks of Yorkshire. The late Professor Phillips tells us in the preface to the third edition of his classical work, *Illustrations of the Geology of Yorkshire*, how he had, in company with his uncle, William Smith, 'the Father of English Geology,' gathered fossils beneath the romantic cliffs of Whitby and Scarborough, but that in 1824 he had the good fortune to become acquainted with two of the most valuable of all his early friends, Mr. William Bean and Mr. John Williamson (the father of the future professor), and to profit by their admirable collections of recent and fossil shells, crustacea, echinida and corals, dredged from the neighboring sea, or hammered out of the adjacent rocks. The father naturally trained his son William to pursue studies which were so fascinating to himself, and, in consequence, the father and the son became inseparable companions."

But the Williamsons were not people of

great means, and the young scientist had to be apprenticed to a surgeon in Scarborough, where he remained from 1832 to 1835. It was during this period that he furnished the data above mentioned, to Lindley and Hutton's Fossil Flora, but he also published over his own name a number of papers on various other subjects, which displayed a wide knowledge of nearly every branch of natural history. These contributions gained for him the curatorship of the Natural History Society of Manchester, where he remained the next three years. He studied medicine and surgery, and in 1840 became a member of the College of Surgeons, and held several important positions, including that of Active Surgeon to the Chorlton-upon-Medlock Dispensary. In 1851 he became Professor of Natural History and Geology at Owens College, Manchester, and from that time until 1892 he followed the fortunes of this noted institution. Then, at the age of 76, he retired from professional labors in order to give himself up exclusively to his great work on fossil plants.

Professor Williamson's labors were by no means confined to vegetable paleontology, and his contributions to other branches of natural history are only less celebrated than those in this field. Mr. Bailey has passed these labors in review in a very satisfactory manner, and I must refer the reader to this sketch for an account of them, confining myself to the only subject on which I am at all capable of expressing an opinion. In 1842 he wrote upon the 'Origin of Coal,'* and in 1854, he returned to the study of the cycadean plant, *Zamia gigas*,† of which he had furnished the sketch for Lindley and Hutton,‡ and upon which

* Brit. Ass. Rept., 1842, Pt. 2, p. 48.

† For such he still modestly called it, although in the paper that immediately follows his in the Trans. Linn. Soc., Mr. William Carruthers renames this plant *Williamsonia*, thus founding one of the best marked genera of fossil plants.

‡ Foss. Fl., Vol. III., p. 45, pl. clxv.

he finally published an elaborate memoir in 1870.* This was his principal contribution to the external parts of fossil plants. Being an adept at the microscope he turned his attention to their internal structure, and found this study so fascinating and so profitable as to allow it to engross almost his entire energies from about the year 1869 to the end of his life.

An important paper appeared in 1869 on the 'Structure and Affinities of Some Exogenous Stems from the Coal Measures,'† and in quick succession during the same and the following years a number of papers describing his studies on the genus *Calamites*.‡ These papers constituted the natural prelude to his great series on the 'Organization of the Fossil Plants of the Coal Measures,' the first of which related to the genus *Calamites* and appeared in 1871.§ From this date these memoirs continued to appear in the Philosophical Transactions at the rate of a little more than one each year, so that the last memoir, of which he was the sole author, is No. 19, and is to be found in the 184th volume, published in 1893.

After his removal to London, in 1892, he associated with him the accomplished structural botanist, Dr. D. H. Scott, Honorary Keeper of the Jodrell Laboratory at Kew, and they worked together in the preparation of an additional memoir, which was laid before the Society on December 30, 1893, and an abstract of which appeared in the Proceedings of the Royal Society, Vol. LV., 1894, without illustrations. This

*Trans. Linn. Soc., Vol. XXVI., 1870, pp. 663-674, pl. lii.-liii.

†Monthly Microsc. Jour., Vol. II., London, 1869, pp. 66-72, pl. xxii.

‡Proc. Lit. Phil. Soc. Manchester, Vol. VIII., 1869, pp. 36-38; 153-155; Vol. IX., 1890, pp. 7-9; 76-78; Mem. do., 3d Ser., Vol. IV., 1869, pp. 155-179; 1871, pp. 155-183; 284-265; Vol. V., 1871, pp. 28-46, pl. i.-iii., etc.

§Phil. Trans. Roy. Soc. London, Vol. CLXI., 1871, pp. 477-510, pl. xxiii.-xxix.

memoir relates to *Calamites*, *Calamostachys* and *Sphenophyllum*. At the Oxford Meeting of the British Association Dr. Scott laid before the Botanical Section the principal results of this investigation, accompanied by profuse illustrations projected on the screen. As I had read the abstract before leaving America, I was naturally deeply interested in this paper, which it was my good fortune to hear. I had written to Professor Williamson that I intended to attend the British Association, and had received a reply in which he stated that he would not be present and begged me to visit him at his country cottage in Sussex, which, to my great regret, I was unable to do. But at Oxford I received another letter from him, renewing his invitation and alluding in no uncertain terms to certain tendencies in modern science which he had always deplored. This part of his letter contains so clear an expression of his views on this question, which he had never published, that I cannot do better than to quote it here.

"I had intended coming to Oxford to utter my final protest against the growing multitude of Paleobotanical species mongers who are reducing the study of Paleobotany to a state of inextricable confusion. But I concluded that I should only expend my breath for nought and become engaged in angry controversies, hence I resolved to leave the entire race who find pleasure and renown in attaching the mystic 'mihi' to the vast number of unidentifiable fragments that have now been accumulating from the days of Artis, Sternberg and Brongniart to the present day. I refuse to recognize any one of my names given in my numerous memoirs as being *specific*. They are merely convenient terms helping us to identify certain types of organization—any one of which may embrace an indefinite number of true species, if indeed any such have a real existence."

To the discussion of Dr. Scott's paper considerable scope was given, and the question involved in the above extracts from this letter occupied the attention of the members. Being called upon by the courteous President of the Section, Prof. Isaac Bailey Balfour, to make some remarks, and having little to say further than to express my great interest in the subject, I felt that I could not better contribute to the discussion than by reading the above extract, which I took the liberty to do.

Although Professor Williamson's labors were so largely confined during the last 25 years of his life to the preparation of this series of memoirs, it must not be supposed that this was all he accomplished. The number of his minor contributions during this period is very large indeed, and several of these papers are of great importance. Especially is this the case with his Monograph of the 'Morphology and Histology of *Stigmaria ficoides*,' published in 1887, which is by far the most complete treatise thus far known on this subject. The total number of his titles, so far as I have been able to collect them together, does not fall far short of 150. This is exclusive of all papers relating to other branches of science, of which there is a great number, including many addresses and lectures. But nearly all of his papers are devoted to setting forth the results of special investigations, chiefly microscopic, upon a great variety of material, which, by the aid of a large corps of trusted collaborators and collectors, he had accumulated in his cabinet. He rarely indulged in philosophic discussion, but on one or two occasions he took a broad view and expressed himself on the larger subjects connected with his lifework. This was notably the case in his address on 'Primeval Vegetation in its Relation to the Doctrines of Natural Selection and Evolution,' published in a volume of Essays and Addresses by Professors in Owens College, Manchester,

in 1874, and reviewed by Dr. Asa Gray in the 'American Journal of Science' in the same year.* To the same class also belonged his 'Primitive Ancestors of Living Plants and their Relations to the Doctrine of Evolution,' published in the 'Revue internationale des sciences biologiques' for September, 1883, but there was scarcely a subject in the whole range of paleobotany which had been prominently brought forward by other writers upon which he had not expressed his opinion.

Only once was it my good fortune to meet Professor Williamson. On the occasion referred to, when I met Dr. Scott at Oxford and had appointed a day to examine with him at the Jodrell Laboratory the microscopic slides of *Bennettites Gibsoni* and other species prepared by Count Solms-Laubach, which were in his hands, Dr. Scott, without my knowledge, notified Professor Williamson of this appointment, and when I reached Kew, to my great delight, I found him there. The two or three hours which I spent in his society can only be characterized as charming. Many subjects were discussed, among the most interesting being his friendly differences with the French paleobotanists, and he related in a playful manner how he had gone about it to secure the publication of one of his most telling replies to the French School in the 'Annales des sciences naturelles,' in which they themselves chiefly published—a bomb, as it were, in the enemy's camp. In parting he said to me with moisture in his eyes, "We shall never see each other again." And so it has proved.

If I were to specify which one of the many important discoveries that Professor Williamson has made in the field of paleobotany ought to be regarded as the most valuable, I should not hesitate to name his demonstration of the existence of exogenous structure in the Carboniferous Pteridophytes, or, more broadly stated, the irrefrag-

* 3d Ser., Vol. VIII., pp. 150-151.

able proof which he has brought forward that exogenous structure is not confined to the Spermophytes. That it is so confined was simply a dogma of botany, and when Brongniart, in his classical memoir on *Sigillaria elegans*, published in 1839, so clearly proved that the genus *Sigillaria* sometimes has such a structure, influenced by this dogma alone, he inclined to place it in the Gymnosperms, and so great was his authority that until very recent times, and to some extent still to-day, his followers in France have labored to sustain that view. Long after Professor Williamson had overthrown it definitively the French School continued to defend it, and it was for this reason that he was induced to contribute the paper above referred to in the 'Annales des sciences naturelles.*' He was determined that they should not have the excuse that his researches were in a language with which they were not familiar, and therefore associated with himself Dr. Marcus M. Hartog, of Victoria University, Manchester, and with the aid of a literary friend of Dr. Hartog in Paris, who put the paper into the very best of French, he set forth in the clearest manner the leading arguments in opposition to the old doctrine, and thrust it directly before the eminent defenders of that doctrine. The effect was instantaneous. The article was read and repeatedly answered, but without weakening the argument, and to-day, with perhaps a single exception, Professor Williamson's conclusions are accepted by the French paleobotanists.

LESTER F. WARD.

WASHINGTON, D. C.

JAMES C. PILLING.

JAMES CONSTANTINE PILLING, a well-known student of the languages and litera-

* Les Sigillaires et les Lepidodendrées, Par. MM. W. C. Williamson et Marcus M. Hartog. Ann. Sci. Nat., Bot., 6e Sér., Vol. XIII., Paris, 1882, pp. 337-352.

ture of the Indians of North America, the bibliographer in the Bureau of American Ethnology, died of locomotor ataxia July 26, 1895. He was born in Washington, November 16, 1846, and passed through the public schools and Gonzaga College. At twenty he was a court and Congressional stenographer. In 1875 he became connected with the United States Geographic and Geologic Surveys of the Rocky Mountain region, under Major J. W. Powell. While in the field he displayed notable skill and zeal in the collection of the vocabularies of the native tribes, his experience in stenography proving of great service. By his aid the Director of the Survey was able to collect a large number of myths and traditions, and to record ceremonials with a fulness of detail which would have been impossible without the use of shorthand. In 1881 Mr. Pilling became chief clerk of the Geological Survey and the Ethnologic Bureau, retaining this arduous position until 1891, when failing health compelled discontinuance of a part of his work; thereupon he resigned from the Survey, discontinued administrative work, and devoted his remaining energies with remarkable persistence and success to bibliographic researches. These researches were continued until April last, when he finally became incapacitated.

Mr. Pilling was widely known as a bibliographer of the native languages of North America. Nine parts of his great bibliography have been published, viz.: the Algonquian, Athapascan, Chinookan (including the Chinook jargon), Eskimo, Iroquoian, Muskhogean, Salishan, Siouan and Wakashan. These volumes comprise about 1,700 pages, including over 6,000 titular entries. The work is regarded as a model by bibliographers generally; the successive parts have been favorably reviewed in scientific journals in many countries. Much additional material was prepared, including a

bibliography of the native languages of Mexico, which is nearly ready for publication.

Among his friends and associates Mr. Pilling was highly esteemed for integrity, industry, kindly disposition and strong sense of justice. By reason of these qualities he was a successful administrative officer, contributing much to the accomplishment and prestige of the scientific bureaus with which he was connected.

W J MCGEE.

AGROSTOLOGY IN THE DEPARTMENT OF AGRICULTURE.

THE Secretary of Agriculture recommended to the last Congress the establishment in his Department of a division to be known as the 'Division of Agrostology.' This recommendation was approved by Congress, and the law establishing the new division went into effect the first of July. This law authorizes investigations relating to the natural history, geographical distribution, and uses of the various grasses and forage plants and their adaptability to special soils and climates. It also authorizes the preparation of special reports, illustrated circulars of information, bulletins and monographic works on the grasses and forage plants of North America. From this it will be seen that both the practical and scientific sides of the grass and forage questions are to be considered, and in the organization of the division force the Secretary endeavored to cover and provide for all the possible lines of work. The farmer and the botanist are alike interested in it. The Department of Agriculture has always recognized the importance of the investigation of our forage resources, which, at a conservative estimate, have a money value of more than one billion of dollars; and, while the establishment of the new division may not introduce new lines of work, it can not fail to effect a better organization of this work and at the same time demon-

strate to the citizens of this and other countries that the United States Government fully appreciates and recognizes the primary importance of the grasses in the rural economy of the Nation. It gives to the work a recognition which its vast importance unquestionably merits.

No country in the world possesses so great and varied forage resources as the United States, and there is none where the maintenance and improvement of these resources is of greater importance. There are over 3,500 different kinds of grasses in the world, more than 700 of which grow within our territory; and besides these grasses there are many useful forage plants which are native to the country, or which have been introduced here from abroad, such as the clovers, alfalfa, the vetches and cow-peas. It will be the function of this new division to instruct and familiarize the people with the habits and uses of all these plants, and to introduce into cultivation promising native and foreign kinds, as well as to identify all grasses and forage plants submitted to the department for identification, and to answer all correspondence relative to these plants.

When the bill for establishing the Division of Agrostology was before the Senate, one Senator remarked: "It is only necessary to state that the grass crop of the country is the foundation of the life of all the animals of the country, to show how important the subject is. What farmers have been doing in past years has been simply to run out the grasses which they had. No attention has been paid to the cultivation and development of grasses, and I am glad to see that the Department of Agriculture is turning its attention to this subject, the most important subject within its purview." Another Senator said, in reference to improving the forage resources of many parts of the semi-arid regions of the West: "It seems to me that in the line

of this investigation, no matter how much it costs, even an appropriation of fifty times the amount carried by the bill, could be profitable expended, if one grass can be obtained of utility to man that will flourish as those worthless plants flourish in that dry arid region."

The division has now in preparation a popular work on the grasses and fodder plants of the country, designed chiefly as a ready reference book for the use of farmers, and also a more elaborate and fully illustrated hand-book of the grasses of North America. The former work will be completed within a year, while the latter, owing to the time required in preparing and executing the illustrations, can not be completed at so early a date. Much time is occupied in the office in identifying grasses sent in by collectors and correspondents, and parties are now in the field, working under the direction of the Chief of the Division, collecting grass seeds, live roots of grasses and forage plants and herbarium specimens, both in the Rocky mountain region and in the Gulf region of the Southern States. Special attention will be given the present season to the sand binders of the Atlantic coast, and to the grasses and other fodder plants which enter into the composition of the hay of the tide-water marshes along the Middle and New England States. This subject, while apparently of local importance, is one of considerable general interest and of much value, as any one who has visited our coasts can not fail to recognize. The agents in the West have been directed to collect in considerable quantity the seeds of all the more promising grasses of the rich grass flora of the Rocky mountain region, with a view of testing the several species under cultivation, particular attention being given to those kinds which appear to thrive and make vigorous growth under the most trying conditions of the arid climates.

The study of living plants and observing their habits of growth, whether in their native station or under cultivation, is absolutely essential to their proper investigation, and to meet this requirement the Secretary has established a grass garden upon the Department grounds, in which already some 400 different varieties of grasses and forage plants are now growing. Owing to the limited area of this garden, the plots assigned to each species are necessarily small, but they are sufficient to test the possibility of the growth of the several kinds in this latitude, and to show very well the peculiar nature of each species. It has been the endeavor to have in this garden illustrative living samples of all the various hay and fodder plants and all grasses advertised by different seedsmen, and to bring together in it all the native grasses which it may be possible to secure. A larger garden, of several acres in extent, has been established in one of the Southern States, where the native grasses peculiar to these States are being tested, and where a considerable area is given to the cultivation of the more promising fodder plants believed to be best adapted to our southern latitudes, both for the purpose of giving these plants a test of a more practical character, such as they would be likely to receive in general culture, and to secure seeds for distribution in cases where such a distribution seems to be desirable.

F. LAMSON SCRIBNER.

DIVISION OF AGROSTOLOGY,
DEPARTMENT OF AGRICULTURE.

PHOTOTOPOGRAPHY.

PHOTOGRAPHS obtained on vertically exposed plates, using a camera with constant focal length and a lens ground especially with a view towards reducing astigmatic and chromatic aberrations to a minimum, giving uniformity in definition and depth over a flat field, may be regarded as geometrically true perspectives.

The true dimensions of objects, represented in perspective view upon a plane surface, are not obtainable by direct measurements with any one scale, but they can be determined, geographically, if the *distance line* (focal length), the *horizon* and the *principal point* are known.

Iconometry, photogrammetry or metro-photography are terms applied to that art which ascertains, graphically, the true dimensions of objects from their perspective correct (photographic) representations (produced by means of a so-called photogrammeter).

By applying the inverse rules of perspective drawing and aided by a knowledge of descriptive geometry, the horizontal projections of the terrene, obtained by means of a photogrammeter, can be plotted in precisely the same manner as if the measurements were made in the field, instead of being obtained from such photographs.

The fundamental principles underlying this particular branch of photogrammetry—'phototopography'—are, of course, the same as in all other methods of topographical surveying, inasmuch as all require the determination of lengths of lines and angular measurements of the deflections of such lines from a given direction.

Generally speaking, phototopography follows the same lines of procedure as the plane table methods, except that with the latter the control underlying the map is plotted and the chart is drawn in the field, the terrene of the mapped area being before the eyes of the plane-tableer, whereas the iconometrical draughtsman has only the perspective views of the terrene, as seen from known stations, from which he must while in his office gather all the data necessary to construct the same map. Still, the latter has the advantage that he can, at any time, refer back to the terrene (pictorially at his command) surrounding any station, while the plane-tableer rarely occupies the same station twice,

notwithstanding such references are very essential aids towards giving the topography a correct interpretation with respect to forms.

In both cases the chart is constructed by means of visual rays or lines of direction, drawn from different stations towards the same point, the cartographic position of which is found by locating the point of intersection of such lines, observed from different stations.

With the plane-table such intersections are made (or plotted) by bisecting the objects or signals with the (telescopic) alidade, and actually drawing the lines of direction observed from different stations to the same point, upon the plane-table sheet, thus plotting the horizontal angles (graphically) without knowing their values in arc.

In phototopography the lines of direction (in both the vertical and horizontal sense) to the various points, identified on different panorama views and selected for plotting, are found by transposing linear measurements taken (as rectangular coordinates) from the negatives or prints, which, together with the camera constants, will enable the iconometrical draughtsman to graphically locate the lines of direction and plot the points (selected on the pictures) by intersections of the same.

Such being the case, it is evident that the smallest length measurable with eye and scale will represent the limit within which the points of the map can be correctly laid down, and it becomes advisable to use a large scale for good photogrammetrical plotting.

The work of drawing in the horizontal contours, after a sufficient number of points have been located on the chart, hypsometrically and geographically, is done in the same manner (by graphical interpolation) as in the field, when using the plane-table, except that in iconometrical plotting frequent reference is taken to the pictures of

the area in question (as seen from different camera stations), they being studied in the same way as the plane-table studies the surrounding terrene to grasp its characteristic forms and represent the same on the map as a faithful translation.

Among the advantages of applying photography, in the manner suggested, to surveying are:

1. With the same material brought home from the field, large or small scale maps can be constructed, and the plotting can be made detailed or generalized by deducing a large or a small number of geodetic control points from the photographs.

2. The phototopographic map construction can be carried on at the home office while the observer remains in the field, sending in the data as soon as they may be acquired. This renders metrophotography especially well adapted for the use of scientific explorers.

3. The field season is reduced to a minimum, no instrumental observations being required beyond the triangulation which forms the basis for the map. Hence, this method is to be recommended for surveys in mountainous regions, in arid countries or where fogs and smoke prevail, in short, where it is desirable to gather much topographical information in a short time.

Since this method has been developed it has been used successfully by explorers, topographers, military engineers, geologists, hydrographers, etc.

It has been employed with marked success for topographical surveys of large areas in mountain regions in Italy (Mil. Geographical Inst., L. P. Paganini), Austria (Professor Steiner, Pollack, Hafferl, Hübl, Lechner, etc.); Canada (Capt. E. Deville, Surveyor General); France (Col. A. Laussedat; Commandants Javary, Moessard and Le Gros; Dr. Le Bon, Ed. Monet, etc.); and in Germany (Dr. Meydenbaur, Dr. Doergens, Dr. Hauck, Dr. Vogel, Professor

Jordan, Dr. Koppe, Dr. Pietsch, etc.). Also for astronomical observations photography has been applied in a similar manner by M. G. Flammarion in France and by Dr. Stolze and C. Runge in Germany.

Photography is being practiced now in Greece, Spain, Portugal, Norway, Mexico, Chile, Peru, Brazil, Switzerland, England, and more recently still in the United States, although this art-science has been taught, both in theory and practice, at the Military Academy at West Point by Lieut. H. A. Reed for several years past.

The Coast and Geodetic Survey has, in the past and in the present season, used the phototopographic method in a modified form for the topographical reconnaissance of regions in southeastern Alaska; while photography has been used exclusively by the Dominion Land Surveyors for similar work along the boundary between Alaska and British Columbia under Dr. W. F. King, Commissioner to H. M. in 1893 and 1894.

J. A. FLEMER.

WASHINGTON, D. C.

THE INTERNATIONAL CATALOGUE OF
SCIENTIFIC LITERATURE.

The committee appointed by the President and Council of the Royal Society to enquire into and report upon the feasibility of a catalogue of scientific literature through international coöperation presented their report on July 5th. It is as follows (we quote from *Nature*):

At the first meeting of this Committee (February 8, 1894), the Memorial to the President and Council (July, 1893) which led to the appointment of the Committee, and the Minute of Council of December 7, 1893, appointing the Committee, having been read, it was resolved to request the President and Council to authorize the Committee to enter directly into communication with societies, institutions, etc., in this country and abroad, with reference to the

preparation, by international coöperation, of complete subject and authors' catalogues of scientific literature.

Subsequently, a draft circular letter was prepared, which, on February 22, 1894, received the approval of the President and Council, who also authorized its issue.

This letter was sent to 207 societies and institutions selected from the exchange list of the Royal Society, and to a few others. It was also sent to the directors of a number of observatories and of government geological surveys, to the foreign members of the Royal Society, as well as to those of the following societies: Chemical, Geological, Physical, Royal Astronomical, Linnæan, Royal Microscopical, Entomological, Zoological, Physiological and Mineralogical, and of the Anthropological Institute. A special letter was addressed to the Smithsonian Institution.

More than a hundred replies to the letter have been received; several of these are reports of committees specially appointed to consider the suggestions put forward by the Royal Society. A list of answers received up to December, 1894, with brief excerpts from the more suggestive, was issued to members of the Committee early in this year. It should, however, be added that from some important institutions no answer has as yet been received.

It may be said at the outset that in no single case is any doubt expressed as to the extreme value of the work contemplated, and that only two or three correspondents question whether it be possible to carry out such a work. It is a great gratification to the Committee that the matter has been taken up in a most cordial manner by the Smithsonian Institution, the Secretary of which, in his reply, refers to the desirability of a catalogue of the kind suggested as being so obvious that the work commends itself at once. The importance of having complete subject catalogues, and not mere

transcripts of titles, is also generally recognised.

Some bodies and individuals take the matter up very warmly and urge that steps be taken forthwith to put the scheme into action, this being especially true of the replies received from the United States; others, while giving a general approval, dwell upon the difficulties of carrying out the suggestions put forward; and others, again, ask for more details before committing themselves to any answer which may seem to entail future responsibility, especially of a financial character.

Incidentally it may be pointed out as very noteworthy that over and over again reference is made to the great value of the Royal Society's 'Catalogue of Scientific Papers.' There is abundant evidence that considerable use is made of this on the continent of Europe. And it is clear that a proposal to carry out a more comprehensive scheme initially under the direction of the Royal Society of London is likely to meet with general approval, owing to the fact that the Society is credited with having already carried out the most comprehensive work of the kind yet attempted. Indeed, the Academy of Natural Sciences of Philadelphia, U. S. A., directly advocates the establishment of a central bureau under the Royal Society; and several others more or less clearly imply that they would favor such a course.

Over and over again, it is stated that the production, by international coöperation, of a catalogue such as is contemplated is not only desirable but practicable. The Americans, who, as already stated, are the most enthusiastic supporters of the scheme, especially dwell on the importance of early action being taken. Professor Bowditch, of Harvard University, in particular, points out that if the Royal Society of London wish to guide the enterprise it ought to announce its views and put forward a compre-

hensive scheme with the least possible delay. It may be added here that he also urges that in determining the scope of the catalogue a very wide interpretation should be given to the word 'Science.'

No very precise information as to the best mode of putting the scheme into operation is to be gathered from the replies as a whole.

It is generally agreed that the enterprise should be an international one. Many think that international financial support should and would be accorded to it, but no method of securing this is indicated; others express the view that the cost may be met by subscriptions from societies, libraries, booksellers and individuals without government aid, and this is, perhaps, on the whole, the prevailing feeling among those who have discussed the matter from a financial point of view. But in no case is any attempt made to form any exact estimate of the cost.

A number of scientific bodies and institutions express themselves prepared to work in such a cause. The Secretary of the Smithsonian Institution suggests that, as the Institution receives all the serials and independent works published in America, a branch office might be established there, and that it is not impossible that a sum of money might be given yearly in aid. The Royal Danish Academy is willing to render as much assistance as possible. It would charge an official of one of the Danish chief libraries in receipt of all Danish publications with the task of editing slips, and would defray the cost of this work. The Société des Sciences of Helsingfors would furnish the central office with information as to the scientific work done in Finland. The Kongl. Vetenskaps Akademi of Stockholm would organize a Committee for Sweden.

As regards language, there appears to be more unanimity than could have been expected. Over and over again the opinion

is expressed that English should be the language of the subject catalogue. Frequent reference is made to the importance of quoting titles in the original language, although some suggest that this should be done only in the case of those published in English, French or German, and perhaps Italian.

Some form of card catalogue appears to be generally favored, especially in America, as the basis of the scheme; the Committee of Harvard University, whose reply is very full, in particular discuss this point in detail.

In an interview with the Committee in March last, Professor Agassiz spoke very warmly in favor of the scheme, and of the support which it would meet with in the United States, especially from libraries. As others have done, he urged that the cooperation of booksellers and authors should be secured. Professor Agassiz also expressed the view that the regular issue, to libraries and scientific workers, from the central office, of cards or slips which would afford the material for the construction of card catalogues would form an important source of income, at all events in his country.

From various sides it is urged that an International Congress should be held to discuss plans. This is advocated as a first step in a reply received from the Königl. Gesellschaft der Wissenschaften in Göttingen, a reply to which, not only as regards this point, but also in respect to the whole matter, the Committee attach very great weight, since it embodies in an official form views arrived at by the Academies of Vienna and Munich, and by the scientific societies of Leipzig and Göttingen, who have considered the matter in common. Professor Agassiz strongly urged the calling of a conference, and among others who share this view, Dr. Gill, of the Cape Observatory, in his letter particularly dwells on

the great value of such meetings as the means of securing unanimity of action.

Such being the tenor of the correspondence, your Committee are convinced that initial steps of a definite nature in furtherance of the scheme ought now to be taken.

They accordingly request the President and Counsel to take measures with the view of calling together, in July of next year (1896), an International Conference, at which representatives of the several nations engaged in scientific work should be invited to attend, with the view of discussing and settling a detailed scheme for the production, by international coöperation, of complete authors' and subject catalogues of scientific literature.

London will probably be found the best place in which to hold such a conference. It may be desirable to summon the representatives of the different countries through their respective governments, and it will obviously be necessary that a detailed scheme be prepared, to serve as a basis for discussion at the conference. These and other points will require much consideration before any action at all can be taken; meanwhile it is desirable that a beginning should be made during the autumn, before the winter session of the Society. The Committee therefore recommend that the President and Council should give the Committee (which includes the President and officers) executive powers in order that they may take, in the name of the Society, such steps as they may think desirable, with the view of calling together the above-mentioned conference.

NOTES FROM LONDON.

A DAY with Mr. Maxim and his wonderful gun and more marvelous flying-machine has proved one of the most interesting of our tour to date. The flying-machine is completely repaired, and in as good working order as before its famous flight and

unlucky accident. Mr. Maxim's lease has nearly expired, however, and little more can be done until he is reëstablished in new quarters. He has, at Bexley, only about 1800 feet range, and for further operations desires at least a mile. It may be difficult to find precisely the location suitable for the work. It would be fortunate for the inventor, for science and for the country, could the new location be found in the United States, with ample funds for the experiment. Mechanically, the machine is a success; but much experience is likely to be required to give its operation certainty and safety. The reduction to practice of the art of flying may probably prove a more serious matter than the solution of the purely mechanical problems involved.

THE Maxim gun is perhaps the most extraordinary implement of war ever devised. The pressing of a button is all that is required of the gunner, the gun loading itself and firing automatically, at the rate of 600 to 800 shots a minute, until the finger is removed or until the ammunition is exhausted. All the needed energy in working the mechanism is supplied by the recoil of the barrel of the gun. Hundreds of these guns have been supplied European and Oriental nations, and they have already done much effective work. It seems hardly creditable to the ordnance authorities of the United States that they should have permitted foreign nations to lead in utilizing so great an American invention. Mr. Maxim has not imbibed much respect for our officials, or our methods of treatment of inventors in this department of applied science, from his personal experience at home.

THE Henley races have come and gone, and the most interesting feature, to Americans, proved disappointing. In the races for the Grand Challenge Cup, Cornell won from Leander by an error on the part of the umpire, and was beaten by Trinity Hall. The result is claimed by advocates of the long

stroke, adopted by British oarsmen, and imported into the United States by Yale, to be proof of its efficiency as against the stroke adopted by Cornell for short races.

The friends of the latter deny this, and state that their crew left America in fine condition, having beaten Henley time on their own Cayuga Lake course; that they continued in excellent condition, on this side the Atlantic, making in trial races the best records of the season. Their best figure for 1 mile 550 yards was 7 m. $\frac{4\frac{1}{2}}$ sec., as against Leander's 7 m. 14 sec. Trinity finally beat them in 7 m. 15 sec., 'easily,' although the 'Yankees' held the lead for half the course. In the last two weeks of their stay the Cornell crew had suffered from the enervating effect of the unaccustomed climate, and suddenly lost their staying power. The event was anticipated by those who watched them most closely days before the races. The men themselves say they have lost no faith in boats, stroke or coaching system, and when in condition are ready to meet any crew which appeared at Henley. They had made better time and held their speed on much longer courses.

The matter has some scientific interest and even importance. Improved oarsmanship means much outside athletic circles. There is certainly a stroke of maximum efficiency which will, with a stated expenditure of muscular power, give the greatest possible work in the line of the boat's keel. It is this really important problem that is likely now to be solved on our home waters; for no change is likely to occur on British waters. Yale and Cornell will perhaps finally settle the question by fighting to a conclusion at home.

The *London Times* has been recently publishing letters from its correspondent at Kiel, in which are criticised, by a naval expert, the warships of various nationalities there represented. He considers the 'Col-

umbia' defective in offensive and defensive power, although a marvel of speed, and likely to prove a success in our special province, that of 'commerce-destroyer.' He thinks the French iron-clad 'Dupuy de Lôme' their best approximation to British standards, and speaks very lightly of the ships built by the Russians for their Baltic fleet. The U. S. S. 'New York' is classed with the best.

I HAD the pleasure of meeting Lord Kelvin last week for the first time since the meeting of the British Association of 1884 at Montreal. He bears the added years remarkably well and appears quite as much interested as ever in America, Americans and scientific work on the other side of the Atlantic. He is engaged, with Sir John Lubbock, Lord Rayleigh and other distinguished men of science, in a movement having for its object the erection of a memorial to the late Professor Huxley, whose death, on the 29th ultimo, was a source of grief to all scientific men, and many divines as well, on both sides of the Atlantic.

R. H. T.

LONDON, July 16, 1895.

SCIENTIFIC NOTES AND NEWS.

FOSSIL MAMMALS OF PATAGONIA.

DR. FLORENTINO AMEGHINO, of La Plata, has recently published an important pamphlet, '*Sur les ongulés fossiles de l'Argentine*,' which includes an exhaustive criticism of the recent memoirs of Mr. Lydekker entitled '*A Study of the Extinct Ungulates of Argentina*,' recently noticed in SCIENCE. Dr. Ameghino goes over Mr. Lydekker's work page by page and points out a number of grave errors arising from the fact that the author confined his studies entirely to the collections in the National Museum and did not examine the very rich private collection of Dr. Ameghino. We noted as a special feature of Mr. Lydekker's handsome memoirs that the English and Span-

ish texts are placed in parallel columns. Dr. Ameghino shows that the Spanish translation is full of errors and frequently directly contradicts the statements made in the English text. Most of the criticisms seem to be thoroughly justified. In conclusion Dr. Ameghino says: "It only remains for Mr. Lydekker to recommence his work with more deliberation and more material. If he should decide to do this I offer him my assistance without any reference to his previous oversight of my researches. My collection of fossil mammals of Argentina contains about 750 species, represented by 50,000 specimens, which I place at his disposal with all the accompanying catalogs and notes."

It is very significant that the most striking studies in paleontology at the present time are among the Theromora, or mammalian-like reptiles which Professor Seely is describing from South Africa, and among this rich, true mammalian fauna of South America. Both the South American and South African continents terminate at present in restricted land areas, but both give evidence of a highly varied and rich land vertebrate fauna in Mesozoic and early Tertiary times. These facts alone point to a far greater former extension of these land areas, and even to extensive connections of the southern continents, similar to those which existed in former times between the northern continents. Dr. Ameghino has referred a large number of the Patagonian mammals to the Marsupialia, and they certainly present many striking resemblances to the Australian marsupials, but none which appear to us absolutely demonstrative of marsupial descent.

A STILL later bulletin from Dr. Ameghino contains a notice of the '*Pyrotherium Beds*' which were discovered in 1888 in western Patagonia, in the province of Neuquen. The last expedition made by M. Carlos

Ameghino was especially directed to determining the geological and faunal characters of this formation. From the geological point of view the results obtained are of the greatest importance. The *Pyrotherium* beds are of lacustrine origin and lie in a vast cretaceous basin which is full of remains of Dinosauria. At several points these beds are found to underlie the Patagonian deposits, which are generally considered contemporaneous with our lower Miocene. The region where the beds are exposed is very similar to that of the Rocky Mountain lake basins, absolutely desert, deeply eroded, and almost everywhere so dry that it is necessary to transport the water supply long distances by muleback. The most abundant and characteristic mammal of these beds is *Pyrotherium*. It is referred by Dr. Ameghino to a sub-order of ungulates which he considers as the direct source of the Proboscidea: "If this large mammal had been found in Europe or Asia no one would have hesitated to regard it as uniting the characteristics of the *Dinotherium* and *Mastodon*. The structure of the lower teeth, of the mandible and of the femur is purely proboscidian; the astragalus, however, is of a profoundly different type, and to a certain degree is comparable to that of the marsupials." He considers that the *Pyrotheria* represent a group of ungulates which have relations to the marsupials, but none the less represent the ancestors of the Proboscidea. It is impossible to accept such a conclusion, and it seems difficult to determine from Dr. Ameghino's figures whether this large mammal represents a gigantic marsupial related to the kangaroo or whether it is the long sought placental ancestor of the Proboscidea. It presents a single pair of lower incisors, like those of the diprotodont marsupials, but also somewhat similar to those of the oldest types of *Mastodon*, such as *M. angustigenis*.

COMPARATIVE NEUROLOGY.

WE have just received Dr. Ludwig Edinger's *Bericht über die Leistungen auf dem Gebiete der Anatomie des Centralnervensystems*, 1893, 1894. (Schmidt's Jahrbücher d. Ges. Medicin.) These reviews began in 1885 and the rapid advance of comparative neurology is well indicated by the 345 titles in the present *Bericht*. Dr. Edinger sums up the present tendencies of research as follows :

"It is a special subject of congratulation that investigations are increasing upon the anatomy of the simpler types of brains and upon certain fibre tracts in the lower orders of mammals, in which these tracts are much better displayed than in the higher mammalia, which have been chiefly investigated hitherto. In general, as a result of this work, we have gained a deeper insight, and have placed the relations of certain tracts upon a firmer comparative basis. The admirable method of Marchi has come into more frequent use than heretofore, especially in the study of secondary degeneration in the hemispheres, in the thalami, crura cerebri, and a great many new facts have thus been brought out. Study upon the olfactory fibre tracts has been renewed with great success, after a long interval in which these tracts have been somewhat neglected; in fact, research in this region was completely stagnant until the discovery of the 'glomerular structure' finally made it possible to determine the separate regions of the olfactory system more accurately. This discovery also made it possible to unify the results obtained in comparative anatomy, and to separate a distinct portion of the forebrain with its tracts as part of the olfactory apparatus proper. This discovery also threw new light upon the development of the mantle of the hemispheres, a region in which far more progress has been made since it has been found that there are certain clearly defined cortical

regions with as clearly defined anatomical relations.

"Numerous researches upon the arrangement of the cells in special 'nuclei' of the nervous system give a constantly increasing insight into their finer structure. It should also be specially noticed that during the last two years has been renewed the study of the changes which take place in the ganglion cells during periods of function and rest; in old age, death and in disease. Here is also a field which promises very rich results. * * With the above grounds for satisfaction, I still cannot let the report of this year go by without expressing a regret for the custom, which seems to be constantly increasing, of rapidly publishing isolated and small observations, while longer and more thorough researches are becoming more infrequent. It would be a serious blow to this branch of research, which has hitherto been followed with scientific exactness, if the large number of hastily prepared researches of beginners should gain the preponderance. My warning is especially directed against conclusions of a far-reaching character which are founded upon a limited number of observations."

THE AMERICAN MICROSCOPICAL SOCIETY.

THE eighteenth annual meeting of the Society will be held at Cornell University, Ithaca, N. Y., for three days, beginning on the morning of August 21st. The accommodations afforded by the University buildings, and their equipment for carrying on all lines of microscopical work, add very materially to the attractiveness of Ithaca as a place of meeting. Add to this the richness of both terrestrial and aquatic fauna and flora, and it is almost an ideal place, both to the student of natural history and to those who love beautiful scenery. A large and influential local committee, with Professor W. W. Rowlee as chairman, has

been formed, and everything will be done within its power that will contribute to the comfort and enjoyment of the members and their friends.

The address of the President, Professor S. H. Gage, on 'The Processes of Life Revealed by the Microscope,' will be given on the evening of August 21st, and the preliminary list of papers promised for the meeting already includes twenty-seven titles.

AMERICAN MATHEMATICAL SOCIETY.

THE Society will hold its second summer meeting at Springfield, Mass., on August 27th and 28th, 1895, under the auspices of the American Association for the Advancement of Science. There will be four sessions, two on each day, beginning respectively at 10 a. m. and 2:30 p. m.

Papers are promised by Dr. G. W. Hill, Prof. E. H. Moore, Prof. G. B. Halsted, Prof. J. B. Shaw, Prof. F. Morley, Prof. A. L. Baker, Dr. A. Martin, Prof. J. McMahon, Prof. W. H. Echols and Mr. P. A. Lambert. At the session in the afternoon of the second day, two topics will be open to the Society for general discussion, viz.: (1.) A general subject catalogue or index of mathematical literature. (2.) The mathematical curriculum of the college and scientific school.

Programs of the meeting may be obtained from the Secretary, Prof. Thomas S. Fiske, Columbia College, New York.

THE HELMHOLTZ MEMORIAL.

CONTRIBUTIONS from Princeton to the Helmholtz Memorial, collected by Professor J. Mark Baldwin, are as follows, amounting to \$138:

| | |
|---------------------|------|
| F. L. Patton,..... | \$10 |
| W. M. Sloane,..... | 10 |
| C. W. Shields,..... | 10 |
| C. A. Young,..... | 5 |
| A. F. West,..... | 5 |

| | |
|------------------------|-------|
| Woodrow Wilson,..... | \$5 |
| W. M. Daniels,..... | 5 |
| Allen Marquand,..... | 5 |
| H. C. O. Huss,..... | 3 |
| J. H. Westcott,..... | 5 |
| E. C. Richardson,..... | 5 |
| H. C. Warren,..... | 3 |
| W. Humphreys,..... | 3 |
| F. N. Wilson,..... | 3 |
| Charles McMillen,..... | 3 |
| C. F. Brackett,..... | 5 |
| W. F. Magie,..... | 5 |
| E. H. Loomis,..... | 5 |
| H. S. S. Smith,..... | 5 |
| C. R. Rockwood,..... | 5 |
| L. W. McCay,..... | 5 |
| Taylor Reed,..... | 5 |
| H. B. Fine,..... | 5 |
| W. Libbey, Jr.,..... | 5 |
| Geo. Macloskie,..... | 3 |
| J. Mark Baldwin,..... | 10 |
| Total,..... | \$138 |

GENERAL.

THE tenth number of the excellent series of bulletins issued by the department of geology of the University of California is on *Lawsonite, a New-Rock-Forming Mineral from the Tiburon Peninsula, Marion county, Cal.* The author, Mr. F. Leslie Ransome, describes the crystal form, the optical properties, the chemical composition and the general physical properties and blow-pipe reactions of the mineral. It occurs in the form of white crystals projecting from an outcrop of crystalline chist and also in veins traversing the chist.

AN international congress for the protection of birds useful in agriculture was held recently in Paris, attended by delegates from France, Great Britain, Germany, Austria, Russia, Switzerland, Holland, Italy, Greece and Spain. The congress defined the birds injurious and useful to agriculture and requested all the nations taking part in the congress should pass within three years

laws absolutely protecting useful birds. They are to be neither killed nor taken alive under any circumstances.

ACCORDING to *The Lancet* the number of cases treated gratuitously in the London clinics rose from about two and a-half millions in 1890 to more than four millions in 1894.

AS FAR as can be judged from the cable dispatches, the topic which attracted most attention at the International Geographical Congress was polar exploration. A resolution was passed affirming that the greatest geographical exploration yet to be undertaken was to be pursued in Antarctic fields, in view of great additions to geographical knowledge which must result from such exploration. It was therefore recommended that the assembled scientific societies throughout the world urge in whatever way seems to them most effective that this work be undertaken before the close of the century. The Congress adopted the resolution of the Vice-Presidents recommending Berlin as the place for the meeting of 1896.

PROF. S. J. BROWN, of the United States Naval Observatory, has been sent on a mission with instructions to visit the observatories at Greenwich, Paris and Berlin, and report to the department on their operations and administration.

It is proposed to erect a statue of the anatomist Corydon L. Ford, on the campus of the University of Michigan. Subscriptions are invited for this purpose, which may be sent to Dr. C. E. Stroud, Sandusky, Ohio.

The revised edition of von Helmholtz's great work, 'Handbuch der physiologischen Optik,' is now approaching completion, the 12th part having just been issued. The publication of the new edition was begun in 1885, but proceeded slowly, von Helmholtz being occupied with other work. The eighth part was issued in 1894, but since

the death of von Helmholtz four parts have been published under the editorship of Prof. Arthur König. The part now issued contains sections on binocular vision, on rivalry of the fields of vision and the beginning of a discussion on the psychological theories of binocular vision.

MR. JOHN K. HILLERS, photographer of the Geological Survey, has prepared, under the supervision of Mr. Charles D. Walcott, Director of the Survey, a collection of photographic transparencies for the Atlanta Exposition.

A NUMBER of transfers and promotions have been made in the Weather Bureau by order of Secretary Morton, among which we may note that Edward E. Gerriot has been placed in charge of the Station at Chicago with a salary of \$2,500 per annum, succeeding Willis N. Moore, now Chief of the Weather Bureau, and that Mr. Alexander McAdie has been transferred from Washington to San Francisco.

The Literary Digest is doing excellent work in the popularization of science by publishing each week four pages which contain abstracts and quotations, selected and edited with much skill, in reference to the more generally interesting aspects of scientific progress.

ACCORDING to the *Washington Star* a new departure has been made in the publication work of the Agricultural Department. Hereafter it will call upon specialists in certain lines of agricultural work, though not connected with the office, to make investigations of importance to agricultural interests and to prepare brief papers or articles embracing the results of the work. These will be paid for at rates which the Department regards as reasonable, the funds being provided for in the Congressional appropriations. Many persons well known here and abroad will be asked to contribute.

DR. WILLIAM C. JARVIS, professor of diseases of the throat at the University of New York, died at Willett's Point on July 30th.

DANIEL G. HATCH, of the Bureau of Animal Industry of the Department of Agriculture, died on August 1st.

PROFESSOR G. F. W. SPÖRER, astronomer in the astrophysical observatory at Potsdam, died on July 7th at the age of 73, and Dr. Josef Loschmidt, professor of physics in Vienna, died on July 8th at the age of 74.

PROFESSOR HEINRICH VON SYBEL, the historian, died at Marburg on August 1st at the age of 78 years.

UNIVERSITY AND EDUCATIONAL NEWS.

THE Berlin correspondent of the New York *Evening Post* states that there are an unusually large number of American students now studying in Germany. 109 Americans are matriculated in the University of Berlin, and there are a large number of others pursuing special studies in clinics and other institutions. The total number of American students in the German universities is estimated at 340; it is said that in some of the laboratories nearly half the research work is being done by American students. The fact that the Summer Semester in Germany continues in session until the first of August gives American students an excellent opportunity to become acquainted with German university life and methods without interrupting their academic course at home.

The number of American students studying in Germany far exceeds the number studying in France. This is partly owing to the fact that the German university is more liberal in the admission of foreign students and in the conferring of degrees. A meeting has, however, recently been held at the Sorbonne, under the presidency of M. Gréard, with a view to making modifica-

tions in the rules governing the conferment of academic degrees and other regulations, so that more foreign students may be attracted to Paris.

WE learn from the *Naturwissenschaftliche Rundschau* that Dr. Fr. Richart, *Privat-Dozent* in Bonn, has been elected full professor of physics in the University of Greifswald, as successor to Professor Overbeck. Dr. O. Wiener has been called to the chair of physics in the University of Giessen. Dr. H. Lenk has been made assistant professor of geology in the University of Leipzig, and Dr. Stäckel, of Halle, assistant professor of mathematics in the University of Königsberg.

THE University of Edinburgh has conferred the degree of LL.D. upon Dr. S. Weir Mitchell.

THE Princeton preparatory school, of which Professor John B. Fine is head master, has been purchased by a number of the alumni of Princeton College and incorporated under the laws of New Jersey.

IT is reported by cable from Dublin that it is probable that the government will shortly bring forward a plan to establish and endow a Catholic university in Ireland.

THE will of the late Thomas O. P. Burnham gives nearly \$400,000 to charitable and public purposes, including \$20,000 to the Massachusetts Institute of Technology and \$10,000 to Tufts College. The will of the late Dr. Edward Spalding gives \$5,000 to Dartmouth College; \$3,000 has reverted to Dartmouth College as provided for in the will of the late Sophronia C. Thompson.

A COMMITTEE from the Legislature of the State of Kansas finds that nearly \$200,000 of the State School Fund has been lost through mismanagement. The fund now amounts to between six and seven million dollars.

THE State Department has received a report from the consul at Stuttgart, in which

he attributes the extension of the German export trade to the Stuttgart Geographical Society and similar institutions.

THE University of Minnesota at its commencement of the current year conferred 294 degrees as follows: Science, Literature and the Arts, B. A., 28; B. S., 32; B. L., 34; M. A., 3; M. S., 6; Ph. D., 1. Engineering, Metallurgy and the Mechanic Arts, B. C. E., 4; B. M. E., 3; B. E. E., 7; B. Min. E., 1; Min. E., 1. Agriculture, 2. Law, LL. B., 88; LL. M., 2. Medicine and Surgery, M. D., 53. Homeop. Medicine and Surgery, M. D., 5. Dentistry, D. D. M., 12. Pharmacy, Phm. D., 12.

CORRESPONDENCE.

WHAT IS 'HIGH WORK'?

THE students of the physiology and morphology of plants are fond of saying that these features of plant life stand for higher work than the older systematic treatment of botanical objects. My attention is called to this attitude of mind at this time by Professor Trelease's remark (although he himself does not subscribe to the sentiment) in SCIENCE for July 5th, in reviewing Mr. Small's excellent monograph of *Polygonum*, that "it is generally believed that the classification and naming of plants is a less advanced branch of botanical investigation than the study of their morphology, development and physiology." I must strenuously object to a comparison of natural objects in terms which are subjective to the student. There is no higher or lower in the forms of life, or in the problems which center about them. Every item in the material universe is worthy the attention of the best mind for a lifetime, and it is bigotry for one student to measure other subjects by the standard of his own specialty. 'High work' is entirely a subjective matter, and is not a quality of the object studied. One man may do 'higher' or 'more advanced' work

studying road dust than another may in studying star dust.

L. H. BAILEY.

SCIENTIFIC LITERATURE.

The Female Offender. CESAR LOMBROSO and WILLIAM FERRERO. With an introduction by W. DOUGLAS MORRISON. Illustrated. The Criminology Series. New York, D. Appleton & Co. 1895. 8°. Pl. 313.

The present work of Lombroso has an introduction by Mr. Douglas Morrison, a perusal of which should disarm all criticism against the body of the work which follows, for Mr. Morrison assures us that the essential aim of Lombroso's work here is to show the public that there are different kinds of criminals and that different kinds of punishments should be provided for them. In other words, the book is a contribution both to penology and to philanthropy. It is encouraging at this time to hear such words of kindness regarding the Italian criminologist. Largely, perhaps, through the instrumentality of Dr. Nordau's extravagances, the literary and artistic public have come to regard Lombroso with great suspicion. The attitude, in fact, toward this philosopher reminds us very much of the attitude of the religious world toward Darwin some years ago. Nothing that that eminent scientist produced was then received without questioning, and the descent of man was as much a matter of public interest and secular joke as is the existence of degenerative traits at the present time.

Lombroso's present work cannot excite much adverse criticism, for the reason that it is largely a collection of facts and statistics, measurements and tables; in fact, so much so that the book becomes rather too technical to interest the general reader. The author endeavors to determine the physical characteristics belonging to the female criminal, including the prostitute.

He gives first a series of anthropometrical measurements of the skull and of the brain, and then describes what he calls the pathological anatomy of the criminal. In other words, those anomalies which would come under the head of pathology, rather than some variation in simple normal measurements.

Professor Lombroso admits that there is very little to be learned from anthropometry in connection with the present study. It is only by comparison of a very large number of very carefully taken measurements that differences between normal and abnormal women can be discovered. It is in the line of the pathological anomalies that he finds the most to attract his attention. Generally speaking, he finds that the anomalies in the female offender are less than in the males of the corresponding class. So far as the skulls are concerned, he states that the skull of criminal woman approximates somewhat to the male skull, especially in the heaviness of the lower jaw-bone, in the exaggeration of the supra-ciliary ridges, and in peculiarities of the occipital region. As regards the brain of female offenders, the anomalies in structure and size are few. There are, however, very often pathological conditions which are of a striking character. Thus in one-third of thirty-three female criminals, there were found gross lesions of the central nervous system.

In making a summary of the chapters on anthropometry of female criminals, Lombroso confesses that the cumulative figures do not amount to much, and he affirms again that the stability of type is much greater in woman than in man. Still he asserts that in female criminals, the height, the stretch of arms and limbs, are less than normal, while in proportion to the height the average weight of certain classes of criminal women is greater than in moral women. Lombroso asserts that grayness is rarer in the normal women than in criminal

women, while baldness is less common in this latter class.

The author's chapter on facial and head anomalies of female criminals seems to us to be full of industriously collected figures, which have, at present, a very slight value. He asserts, however, as a conclusion from a study of them, that these anomalies of the face and body are much more frequent in the female criminal than in the moral classes. The asymmetrical face, strabismus, virile and Mongolian types of physiognomy, out-standing ears, crooked nose, hairiness, prehensile feet, large jaws and cheek bones and anomalous teeth, are among the stigmata that are mentioned. He endeavors to show that certain kinds of criminals have more of these stigmata than others, but no generalization is attempted.

A number of chapters follow upon the physiognomy of female criminals, on tattooing of the offender and on the acuteness of their various special senses, and the book concludes with studies upon the psychology of the born criminal, the occasional criminal and discussions upon hysterical criminals and crimes of passion.

The book as a whole leaves the impression that the author has not made very much headway in establishing a criminal type which can be determined by physical characteristics alone. Still, he has accumulated a large number of facts, and when this is still more increased, particularly by observations on normal women and upon women of different races, some deductions may perhaps be drawn.

The general chapters which bear upon the subject of the production of criminals are interesting and form a valuable contribution to penology.

CHARLES L. DANA.

NEW YORK.

Bildungselemente und erzieherischer Wert des Unterrichts in der Chemie. VON PROF. DR. RUDOLF ARENDT. VOSS, Hamburg and

Leipzig. 1895. Svo. Pp. 103. Price, 2 marks.

Under the above title Professor Arendt has reprinted the introductory chapters of his book, called 'Technik der Experimental Chemie,' and in these he points out the great advantages that are to be gained by a study of the natural sciences in the secondary schools. In order that the pupils of these schools may gain the greatest possible benefit from such study he recommends that they be taught physics and chemistry, and that the instruction in the purely descriptive sciences, such as botany and physiology, be omitted. In the lower classes he insists that the treatment of these sciences must be purely empirical. Facts must be collected and arranged systematically. All speculative discussion in regard to things that lie beyond what can be observed, and all hypotheses of a metaphysical kind, must be avoided. The minds of the pupils must first be furnished with a sufficiently broad knowledge of the facts of observation before the attempt is made to make a more profound study of physical and chemical phenomena. It is only in the higher classes that subjects of a theoretical nature are to be considered, and then great care must be taken by the teacher to present these subjects in their true light, so that the students may clearly apprehend what is fact and what is hypothesis.

The author considers first how conceptions and ideas are formed in studying changes in material things, then how the results of observation and experiment are to be arranged and classified and how generalizations are to be reached. The inductive method of working is explained in great detail, and the author calls attention to the unusually good opportunity which the study of chemistry offers for making students thoroughly familiar with this method of investigating nature.

The last chapter deals with the practical

details of instruction, what to teach and how to teach it. He recommends what he calls the synthetic method. The course begins with a consideration of the more important metals. The characteristic properties of these are discussed; then the changes that they undergo when they are heated in the air are examined experimentally. The causes of these changes are found to be due to the action of one constituent of the air. By further experiments the student is led to discover oxygen, to determine the composition of air and water. The action of oxygen upon combustibles is then taken up, and this leads to the determination of the nature of combustion. After the student has in this way learned something about the class of bodies called oxides he starts again with the metals and studies the effect of chlorine and sulphur upon them. Thus a knowledge of chlorides and sulphides is obtained. A comparative study is then made of the oxides, sulphides and chlorides, and the methods of transforming the members of one class into those of the other classes are considered. The course of instruction is continued in this way until the student has learned something about all of the more important elements and compounds. Throughout the entire course the inductive method is used, the student being constantly called upon to draw his own conclusions from the experiments and then to test these conclusions by means of new experiments.

Admirable as this plan seems to be for the instruction of young students, where the course can be extended through a series of years, it can hardly be regarded as a satisfactory one for more advanced students. It is only the simpler laws that can be worked out inductively by the students. The greater number have to be imparted to them directly, and the explanation given of how these laws were discovered and upon what basis they rest. The most that the

students can do is to verify some of them by means of one or two examples which illustrate them. Nevertheless, the plan of replacing the purely descriptive work in science by something which makes the students think, and makes them test the accuracy of their conclusions by means of new experiments, is greatly to be recommended.

E. H. K.

SCIENTIFIC JOURNALS.

BOTANICAL GAZETTE, JULY.*

Undescribed Plants from Guatemala and other Central American Republics, XV.: JOHN DONNELL SMITH.

For some years Captain Smith has been exploring the regions named and studying collections made there by others, with the result of finding many new plants which are being described (and some handsomely figured) in this series of papers. Many of the descriptions are contributed by European specialists.

Contributions to the embryology of the Ranunculaceæ: DAVID M. MOTTIER.

This paper, which is richly illustrated by 59 figures, brings to our knowledge considerable variation in the development of the embryo sac in different genera of the family. One of the most striking points is in the announcement of the frequent occurrence in this family also of more than one embryo sac in the ovule and the presence of as many as five or more initial cells of embryo sacs in *Caltha*.

Observations on the development of Colletotrichum lindemuthianum in artificial cultures: GEO.

F. ATKINSON.

This fungus is the one producing the common spot disease (anthracnose) of beans. Having made many failures in germinating the spores in artificial media, Professor Atkinson finally succeeded and gives a detailed account of his successful

methods in this paper. Photomicrographs reproduced in half-tone show his results.

On the validity of some fossil species of Liviodendron: THEO. HOLM.

Mr. Holm criticises paleobotanists for naming scrappy remains of leaves, and takes to task especially Professor Hollick's determinations of some cretaceous plants from Long Island.

The nomenclature question: (1) *Botanical nomenclature and non-systematists*: W. F. GANONG; (2) *Dr. Robinson and homonyms*: FREDERICK V. COVILLE.

The nomenclature question is attracting a great deal of attention at present among botanists. In the first named contribution to the discussion Professor Ganong opposes the proposed reform, because it violates the psychological principles of the use of language, and because it is not likely to obtain a sufficient following to make its nomenclature intelligible. Mr. Coville points out the advantageous working of the law of the rejection of homonyms in a real case, as opposed to its disadvantageous working in the case supposed in a previous note by Dr. Robinson.

In *Briefer Articles* Mr. M. L. Fernald describes a new dandelion with red fruits (*Taraxacum erythrospermum* Andr.) which has made its appearance in New England; an account is given of the Gilbreth botanical collection recently presented to Radcliffe College; Professor W. A. Kellerman reports an apparently authentic case of poisoning of children by eating shepherd's purse; Mr. C. L. Pollard describes a new variety of the arrow-leaved violet (*Viola sagittata Hicksi*) from the District of Columbia; and Dr. L. M. Underwood figures a curiously deformed Equisetum, presumably *E. hiemale*.

Under *Current Literature* are reviewed Oliver's 'Natural History of Plants,' a translation of Kerner's 'Pflanzenleben';

* Issued July 15, 1895. 56 pp., 3 pl.

Potter's translation of Warming's 'Handbook of Systematic Botany'; Darwin's 'Elements of Botany'; Lloyd's illustrations of fungi; MacDougal's 'Experimental Plant Physiology'; Bailey's 'Horticulturist's Rule Book'; Comstock's 'Manual for the Study of Insects'; and Dewey's last weed bulletin. In an *Open Letter* Professor Hollick replies on behalf of paleobotanists to Mr. Holmes' criticisms previously referred to. The number closes with four pages of *Notes and News*.

THE PSYCHOLOGICAL REVIEW, JULY.

The Psychology of Pain. By PROFESSOR C. A. STRONG.

In this article the author reviews the evidence as to a sensation of pain, citing many pathological cases. He concludes in favor of pain as a sensation in addition to the unpleasantness which accompanies mental contents. He does not incline, however, to accept the view that sensation-pain has separate nerve fibres of its own.

Experimental Induction of Automatic Processes.

By PROFESSOR W. R. NEWBOLD.

A detailed experimental study of the visual images induced by steady gazing upon a shining surface, called 'crystal vision.' Many new and interesting experiences and variations are reported. The author takes occasion, on the strength of his experiments, to combat the theory of subconscious trains of ideas or 'secondary personalities' to account for these phenomena; holding that they can be explained as complex responses of the lower centres to stimulation.

Sensory Stimulation by Attention. By PROFESSOR J. G. HIBBEN.

Report of a case—a girl who could not hear except when her attention was directed to the source of the sound. The author discusses other cases of a similar kind and the possible grounds on which a reinforcement

might come to the sensory processes from the processes of attention.

Shorter Contributions; Discussions: including a discussion on 'Shadows of Bloodvessels on the Retina,' by MRS. C. LADD FRANKLIN; 'The New Psychology in Undergraduate Work,' by H. K. WOLFE, etc., followed by *Psychological Literature; Notes*.

PSYCHE, AUGUST.

W. T. BLATCHLEY gives notes on 38 of the Heteroptera observed by him while winter collecting in Vigo County, Indiana. Dr. A. Davidson describes the habits of a Californian Stigmus, a wasp which stores its cells with aphides and notices two parasites bred from the larvæ, one of which is here described by Ashmead. C. H. T. Townsend describes the prickly leaf-gall of *Rhodites tumidus* on *Rosa fendleri* in New Mexico. D. W. Coquillett records the occurrence of *Acreotrichus* in Washington (State), a genus of Diptera heretofore known only from Australia, and describes the species. A. P. Morse describes three new species of North American Odonata of the genera *Nehalennia* and *Enallagma*; and Miss C. G. Soule prints some miscellaneous notes on moths. Brief proceedings of the Cambridge Entomological Club follow.

NEW BOOKS.

Elements of Botany. FRANCIS DARWIN. Cambridge, University Press. 1895. Pp. vii+235. \$1.60.

The Science of Mechanics. ERNEST MACH. Translated by Thomas J. McCormack. Chicago, Open Court Publishing Co. 1893. Pp. xiv+534.

Schneekrystalle. G. HELLMAN. Berlin, Rudolf Mückenberger. 1893. Pp. 66. M. 6.

Annual Report of the Geological Survey of Canada, Vol. VI. Ottawa. 1895. Pp. x+212.

Proceedings of the Iowa Academy of Sciences for 1894, Vol. II. Des Moines. 1895. Pp. 222.

SCIENCE

NEW SERIES.
VOL. II. No. 33.

FRIDAY, AUGUST 16, 1895.

SINGLE COPIES, 15 CTS.
ANNUAL SUBSCRIPTION, \$5.00.

GUSTAV E. STECHERT'S

Recent Importation of Scientific Books.

BECKERT, TH. und DR. ALBANO BRAND. Hüttenkunde. Mit 235 in den Text gedruckten Figuren. 765 Seiten. gr. 8°. Mk. 20.

BEHRENS, H. Anleitung zur mikrochemischen Analyse. Mit einem Vorwort von Prof. S. Hoogewerf in Delft. 224 Seiten mit 92 Figuren in Text. 8°. Mk. 6.

BIEDERMANN, W. Elektrophysiologie. 1^{er} Abtheilung. Mit 136 Abbildungen. 440 Seiten. 8°. Mk. 9.

BORCHERS, DR. W. Elektro-Metallurgie. Die Gewinnung der Metalle unter Vermittlung des elektrischen Stromes. 2^{te} verm. v. völlig umgearb. Auflage. 1^{er} Abtheilung, mit 87 Abbildungen. 160 Seiten. gr. 8°. Mk. 6⁰⁰.

BUSCHAN, GEORG. Vorgeschichtliche Botanik der Cultur-u. Nutzpflanzen der alten Welt auf Grund prähistorischer Funde. 268 Seiten. 8°. Mk. 7⁰⁰.

DAMMER, DR. O. Handbuch der chemischen Technologie. Unter Mitwirkung von Direktor Th. Beckert, Dr. Bender, Dr. Benedikt, Dr. Börnstein u. A. herausgegeben. 2^{ter} Band. Mit 235 in den Text gedruckten Figuren. gr. 8°. Mk. 20.

DELAGE, YVES. La structure du protoplasma et les théories sur l'hérédité et les grands problèmes de la biologie générale. 878 pages. gr. 8° cloth. frs 24⁰⁰.

DETMER, DR. W. Das pflanzenphysiologische Praktikum. Anleitung zu pflanzenphysiolog. Untersuchungen für Studierende u. Lehrer der Naturwissenschaften, sowie der Medicin, etc. 2^{te} völlig neubearbeitete Aufl. Mit 184 Abbildungen. 456 Seiten. 8°. Mk. 9.

FOREL, DR. AUGUST. Der Hypnotismus, seine psycho-physiologische medicinische, strafrechtliche Bedeutung und seine Handhabung. 3^{te} verb. Aufl. mit Adnotationen von Dr. O. Vogt. 223 Seiten. gr. 8°. Mk. 5.

FRANK, DR. A. B. Die Krankheiten der Pflanzen. Ein Handbuch für Land u. Forstwirthe, Botaniker, etc. Erster Band, Die durch anorgan. Einflüsse hervorge. ruhen Krankheiten. Mit 34 Holzschnitten. 2^{ter} Aufl. 344 Seiten. 8°. Mk. 6⁰⁰.

HIS, WILH. Die anatomische Nomenclatur. Nomina anatomica, Verzeichniss der von der anatomischen Gesellschaft auf ihrer 9. Versammlung in Basel angenommenen Namen. Mit 30 Abbildgn. im Text und 2 Tafeln. 180 Seiten. Mk. 7⁰⁰.

HOUDAILLE, F. Météorologie agricole. 204 pages cloth. fr. 3.

JAHRBUCH DER ELEKTROCHEMIE. Berichte über die Fortschritte des Jahres 1894. Im wissenschaftlichen Theile bearbeitet von Dr. W. Nernst. Im technischen Theile bearbeitet von Dr. W. Borchers. I^{er} Jahrgang. 274 Seiten. gr. 8°. Mk. 10.

JERUSALEM, WILH. Die Urtheilsfunktion. Eine psychologische und erkenntnistheoretische Untersuchung. 269 Seiten. Mk. 6⁰⁰.

LOEWY, DR. A. Untersuchungen über die Respiration und Circulation bei Aenderung des Druckes und des Sauerstoffgehaltes der Luft. Mit 5 Curventafeln im Text. 155 Seiten. gr. 8°. Mk. 4.

MEYER, DR. ARTH. Untersuchungen über die Stärkekörner der höheren Pflanzen. Mit 9 Tafeln u. 99 Text-Abbildgn. 318 Seiten. gr. 8°. Mk. 20⁰⁰.

NIEDENZU, DR. FRANZ. Handbuch für botanische Bestimmungsübungen. Mit 15 Figuren im Text. 351 Seiten. 8°. Mk. 4.

SCHAFFER, DR. KARL. Suggestion und Reflex. Eine Kritisch-experimentelle Studie über die Reflexphänomene des Hypnotismus. Mit 6 Tafeln in Lichtdruck und 11 Abbildungen im Text. 113 Seiten. gr. 8°. Mk. 6⁰⁰.

SCHMIDT, DR. ALEX. Weitere Beiträge zur Blutlehre. Nach des Verfassers Tode herausgegeben. 247 Seiten. 8°. Mk. 7.

SCHWARTZE, TH. Die Lehre von der Electricität und deren praktische Verwendung. Mit 153 in den Text gedruckten Abbildungen. 543 Seiten. 8°. Mk. 10⁰⁰.

STEINHARDT, DR. EUGEN. Kurzes Lehrbuch der Chemie zum Gebrauch an Schulen und zur Selbstbelehrung. Zwei Theile. Erst. Theil; Anorganische Chemie. 418 Seiten. 8°. Mk. 6⁰⁰.

VAN BIERVLIET, J. J. Elements de psychologie humaine. Cours professé a l'université de Gand. Avec 34 figures dans le Text. 317 pages. frs. 8.

ZEITSCHRIFT FÜR ANGEWANDTE MIKROSKOPIE herausgegeben von G. Marpmann. Monthly. 1^{er} Band 1^{tes} Heft. Per year, \$2.75.

ZEITSCHRIFT, Geographische, Herausgegeben von Dr. Alfred Hettner. 1^{er} Jahrg. 1^{er} Heft. Per year (12 N^{os}) \$4⁰⁰.

ZIMMERMANN, DR. A. Das Mikroskop. Ein Leitfaden der wissenschaftlichen Mikroskopie. Mit 231 Figuren im Text. 334 Seiten. gr. 8°. Mk. 9.

ZITTEL, KARL A. VON. Grundzüge der Paläontologie (Paläozoologie). Mit 2048 in den Text gedruckten Abbildungen. 971 Seiten. gr. 8°. $\frac{1}{2}$ mor. Mk. 25⁰⁰.

GUSTAV E. STECHERT,

810 Broadway, New York.

Macmillan & Co.'s New Publications.

The Cell: Outlines of General Anatomy and Physiology.

By DR. OSCAR HEFTWIG, Professor Extraordinarius of Anatomy and Comparative Anatomy, Director of the II. Anatomical Institute of the University of Berlin. Translated by M. CAMPBELL and Edited by HENRY JOHNSTONE CAMPBELL, M. D., Assistant Physician to the City of London Hospital for the Diseases of the Chest, etc. With 168 Illustrations. 8vo, cloth, pp., \$3.00, *net*.

The American Commercial Policy.

Three Historical Essays. By UGO RABBENO, Professor of Political Economy in the University of Modena. Second Edition. Partly rewritten and entirely revised by the author. Translated at the Translations Bureau, London, W. C. 8vo, cloth, pp. 414, \$3.25, *net*.

Analytical Chemistry.

By N. MENSCHUTKIN, Professor in the University of St. Petersburg. Translated from the third German edition under the supervision of the Author. By JAMES LOCKE. 8vo, cloth, pp. xii+512, \$4.00, *net*.

The Great Frozen Land. Narrative of a Winter Journey Across the Tundras and a Sojourn Among the Samoyads.

By GEORGE F. JACKSON, Fellow of the Royal Geographical Society and Leader of the Jackson-Harnsworth Polar Expedition. With Illustrations and Maps. Edited from his Journals by ARTHUR MONTEFIORE. 8vo, cloth, pp. xviii+297, \$4.50.

Cambridge Natural Science Manuals.

A Text-Book of Zoögeography. By FRANK E. BEDDARD, M. A. (Oxon), F. R. S., Professor of the Zoological Society of London, and Lecturer on Biology at Guy's Hospital. 12mo, cloth, \$1.60, *net*. (*Biological Series*.)

Second Volume of the Century Science Series.

Edited by SIR HENRY E. ROSCOE, D. C. L., etc. (Biographies of Eminent Men of Science.)

Major Rennell, F. R. S., and the Rise of English Geography.

By CLEMENTS R. MARKHAM, C. B., F. R. S., President of the Royal Geographical Society. 12mo, cloth, \$1.25.

First Volume: John Dalton and the Rise of Modern Chemistry.

By SIR HENRY E. ROSCOE, F. R. S., etc. 16mo, cloth, \$1.25. Other volumes of this series in preparation.

The Horticulturist's Rule-Book.

A Compendium of Useful Information for Fruit-growers, Truck-gardeners, Florists and others. By L. H. BAILEY, Professor of Horticulture in Cornell University. Third Edition, thoroughly Revised and Recast, with many Additions. 12mo, limp cloth, 75 cents.

Short Studies in Nature Knowledge. An Introduction to the Science of Physiography.

By WILLIAM GEE, Certified Teacher of the Education Department and of the Science and Art Departments. Illustrated with 117 engravings, comprising portraits, views, etc. 12mo, cloth, \$1.10, *net*.

MACMILLAN & CO., 66 Fifth Avenue, New York.

SCIENCE

EDITORIAL COMMITTEE: S. NEWCOMB, Mathematics; R. S. WOODWARD, Mechanics; E. C. PICKERING, Astronomy; T. C. MENDENHALL, Physics; R. H. THURSTON, Engineering; IRA REMSEN, Chemistry; J. LE CONTE, Geology; W. M. DAVIS, Physiography; O. C. MARSH, Paleontology; W. K. BROOKS, Invertebrate Zoology; C. HART MERRIAM, Vertebrate Zoology; S. H. SCUDDER, Entomology; N. L. BRITTON, Botany; HENRY F. OSBORN, General Biology; H. P. BOWDITCH, Physiology; J. S. BILLINGS, Hygiene; J. McKEEN CATTELL, Psychology; DANIEL G. BRINTON, J. W. POWELL, Anthropology.

FRIDAY, AUGUST 16, 1895.

CONTENTS:

| | |
|--|-----|
| <i>The Hodgkins Fund Prizes</i> | 169 |
| <i>The History, Aims and Importance of the American Association for the Advancement of Science:</i> F. W. PUTNAM..... | 171 |
| <i>Bolometric Investigations in the Infra-red Spectrum of the Sun:</i> WILLIAM HALLOCK..... | 174 |
| <i>Vertebrate Paleontology in the American Museum:</i> HENRY F. OSBORN..... | 178 |
| <i>The Geographical Distribution of the Molusca:</i> FRANK C. BAKER..... | 179 |
| <i>Current Problems in Plant Morphology (I.):</i> CONWAY MACMILLAN..... | 183 |
| <i>Scientific Notes and News:—</i> | 184 |
| <i>Australasian Association for the Advancement of Science; The Geological Society of America; The Work of Yale Observatory; General.</i> | |
| <i>Correspondence:—</i> | 188 |
| <i>The Causes of the Gulf Stream, The Nature of Vowels:</i> JOSEPH LE CONTE..... | |
| <i>Scientific Literature:—</i> | 189 |
| <i>Menschutkin's Analytical Chemistry:</i> MOREIS LOEB. <i>Patton's Treatise on Civil Engineering:</i> MANSFIELD MERRIMAN. <i>Verity's Electricity Up to Date:</i> J. W. MOORE. <i>Terrestrial Magnetism:</i> L. A. BAUER..... | |
| <i>Scientific Journals:—</i> | 193 |
| <i>The Physical Review; The American Geologist.</i> | |
| <i>New Books</i> | 196 |

MSS. intended for publication and books, etc., intended for review should be sent to the responsible editor, Prof. J. McKeen Cattell, Garrison on Hudson, N. Y.
Subscriptions and advertisements should be sent to SCIENCE, 41 N. Queen St., Lancaster, Pa., or 41 East 49th St., New York.

THE HODGKINS FUND PRIZES.

REPORT OF THE COMMITTEE APPOINTED BY THE SMITHSONIAN INSTITUTION TO AWARD THE HODGKINS FUND PRIZES.

THE Committee of Award for the Hodgkins prizes of the Smithsonian Institution

has completed its examination of the two hundred and eighteen papers submitted in competition by contestants.

The Committee is composed of the following members:

Dr. S. P. Langley, chairman, *ex-officio*; Dr. G. Brown Goode, appointed by the Secretary of the Smithsonian Institution; Assistant Surgeon-General John S. Billings, by the President of the National Academy of Sciences; Professor M. W. Harrington, by the President of the American Association for the Advancement of Science.

The Foreign Advisory Committee, as first constituted, was represented by Monsieur J. Janssen, Professor T. H. Huxley and Professor von Helmholtz; and after the recent loss of the latter, Dr. W. von Bezold was added. After consultation with these eminent men, the Committee decided as follows:

First prize, of ten thousand dollars, for a treatise embodying some new and important discoveries in regard to the nature or properties of atmospheric air, to Lord Rayleigh, of London, and Professor William Ramsay, of the University College, London, for the discovery of *Argon*, a new element of the atmosphere.

The second prize, of two thousand dollars, is not awarded, owing to the failure of any contestant to comply strictly with the terms of the offer.

The third prize, of one thousand dollars,

to Dr. Henry de Varigny, of Paris, for the best popular treatise upon atmospheric air, its properties and relationships. Dr. de Varigny's essay is entitled 'L'Air et la Vie.'

(Signed) S. P. LANGLEY,
G. BROWN GOODE,
J. S. BILLINGS,
M. W. HARRINGTON.

AUGUST 9, 1895.

SUPPLEMENTARY REPORT OF THE COMMITTEE
APPOINTED BY THE SMITHSONIAN
INSTITUTION TO AWARD THE
HODGKINS FUND PRIZES.

After having performed the function to which the Committee was called, as announced by the circular of the Secretary of the Smithsonian Institution, dated March 31, 1893, which function did not include the award of any medals, there remained several papers to which the Committee had been unable to give any prize but to which they had felt desirous to give some honorable mention, and on their representing this to the Smithsonian Institution they have been commissioned to do so, and also to give certain medals of silver and bronze which had been subsequently placed at their disposition.

The Committee has decided that honorable mention should be made of the papers, twenty-one in number, included in the following list, which also gives the full names, titles and addresses of the authors, and the mottoes or pseudonyms which in four instances were employed. To three of the papers a silver medal is awarded and to six a bronze medal.

HONORABLE MENTION WITH SILVER MEDAL.

Prof. A. L. Herrera and Doctor Vergara Lopez, of the City of Mexico: 'La Atmosfera de las altitudes y el bienstar del hombre.'

Mr. C. L. Madsen, ('Geo,') Helsingor, near Copenhagen, Denmark.

Topographical Studies: Mr. F. A. R. Russell, of London, Vice President of

the Royal Meteorological Society of Great Britain: 'The Atmosphere in relation to Human Life and Health.'

HONORABLE MENTION WITH BRONZE MEDAL.

M. E. Deburaux-Dex and M. Maurice Dibos, ('Spes,') of Rouen, France: 'Etudes des courants aériens continentaux et de leur utilisation par des aérostats long-courriers.'

Doctor O. Jesse, of Berlin: 'Die leuchtenden Nachtwolken.'

Doctor A. Loewy, of Berlin: 'Untersuchungen ueber die Respiration und Circulation unter verdünnter und verdichteter Sauerstoffärmer und sauerstoffreicher Luft.'

Mr. Alexander McAdie ('Dalgetty'), of Washington: "The known properties of atmospheric air considered in their relationships to research in every department of natural science, and the importance of a study of the atmosphere considered in view of these relationships: the proper direction of future research in connection with the imperfections of our knowledge of atmospheric air and the conditions of that knowledge with other sciences."

Mr. Hiram S. Maxim, of Kent, England: 'Natural and Artificial Flight.'

Doctor Franz Oppenheimer and Doctor Carl Oppenheimer ('E pur si muove'), of Berlin, Germany: 'Ueber atmosphärische Luft, ihre Eigenschaften und ihren Zusammenhang mit dem menschlichen Leben.'

HONORABLE MENTION.

Mr. E. C. C. Baly, of University College, London: 'The decomposition of the two constituents of the atmosphere by means of the passage of the electric spark.'

Professor F. H. Bigelow, of Washington: 'Solar and Terrestrial Magnetism and their relation to Meteorology.'

Doctor J. B. Cohen, of Yorkshire College, Leeds, England: 'The Air of Towns.'

Doctor F. J. B. Cordeiro, U. S. N., of Washington: 'Hypsometry.'

Professor Emile Duclaux, of the French Institute, Paris, France: 'Sur l'actinométrie atmosphérique et sur la constitution actinique de l'atmosphère.'

Professor Doctor Gieseler, of Bonn, Germany: 'Mittlere Tagestemperaturen von Bonn, 1848-88.'

Doctor Ludwig Ilosvay von Nagy Ilosva, Professor in the Royal Joseph Polytechnic School, Budapest, Hungary: 'Ueber den unmittelbar oxydirenden Bestandtheil der Luft.'

Doctor A. Magelssen, of Christiania, Norway: 'Ueber den Zusammenhang und die Verwandtschaft der biologischen, meteorologischen und kosmischen Erscheinungen.'

Doctor A. Marcuse, of the Royal Observatory, Berlin, Germany: 'Die atmosphärische Luft.'

Professor C. Nees, of the Polytechnic School, Copenhagen, Denmark: 'The use of kites and chained air-balloons for observing the velocity of winds, etc.'

Surgeon Charles Smart, U. S. A., of Washington: 'An Essay on the Properties, Constitution and Impurities of Atmospheric Air, in relation to the promotion of Health and Longevity.'

Doctor F. Viault, of the Faculty of Medicine, Bordeaux, France: 'Découverte d'une nouvelle et importante propriété physiologique de l'Air atmosphérique (action hémotogène de l'air raréfié).'

(Signed) S. P. LANGLEY,
G. BROWN GOODE,
J. S. BILLINGS,
M. W. HARRINGTON.

AUGUST 9, 1895.

THE HISTORY, AIMS AND IMPORTANCE OF
THE AMERICAN ASSOCIATION FOR THE
ADVANCEMENT OF SCIENCE.

THE year 1839 was one of great scientific activity in this country, and in the older States regularly organized geological and zoological surveys were in progress which

had called into the field nearly all the scientific men in the country in various capacities. Many of our earlier scientists owe their fame to the opportunities then offered for solving the great problems in science which were met at every step. At that time science was still in its infancy, and the officers of the several State Surveys felt the necessity of comparing notes and discussing results. As a consequence it was agreed upon among them to form an Association of Geologists and Naturalists which should meet every year and discuss the facts and theories which every man was working out in his own State.

The first meeting of this Association was in Philadelphia in April, 1840, under the presidency of Edward Hitchcock, the head of the Geological Survey of Massachusetts. The second meeting was also held in Philadelphia, the year following, with the eminent chemist, Benjamin Silliman, Sr., of New Haven, as President. This was followed by annual meetings in Boston, Albany, Washington, New Haven, New York, and again in Boston in 1847, under the succession of Presidents: S. J. Morton, Henry B. Rogers, John Lock, William B. Rogers, C. T. Jackson and William B. Rogers for a second time, all of whom were prominent in their respective lines of research and each of whom has left an honored mark on the annals of American science.

At the meeting of 1847 in Boston it was found that during the seven years of the existence of the Association the kindred sciences of mathematics, astronomy, physics, chemistry, geography and ethnology had gained many devotees in this country. Such advances had been made in these sciences as to show the necessity of broader views and more general coöperation among the workers in all departments of science. It was therefore resolved to enlarge the scope of the existing association and to

take in all the sciences by changing the name to The American Association for the Advancement of Science.

In 1848 the new association met in Philadelphia, the birth-place of its predecessor, and adopted the constitution which in all its vital points has remained unchanged to this time. The first clause of this constitution is as follows: "The objects of the Association are, by periodical and migratory meetings, to promote intercourse between those who are cultivating science in different parts of America, to give a stronger and more general impulse and more systematic direction to scientific research, and to procure for the labors of scientific men increased facilities and a wider influence." Acting under this clause the Association has held forty-three meetings in the following cities: Philadelphia twice (in 1848 and 1884), Cambridge, Charleston, New Haven, Cincinnati twice (in 1851 and 1881), Albany twice (in 1851 and 1856), Cleveland twice (in 1853 and 1888), Washington twice (in 1854 and 1891), Providence, Montreal twice (in 1857 and 1882), Baltimore, Springfield, Newport, Buffalo three times (in 1866, 1876 and 1886), Burlington, Chicago, Salem, Troy, Indianapolis twice (in 1871 and 1890), Dubuque, Portland, Hartford, Detroit, Nashville, St. Louis, Saratoga, Boston, Minneapolis, Ann Arbor, New York, Toronto, Rochester, Madison and Brooklyn.

At first it was contemplated to hold two meetings each year, one in the early spring, mainly in the Southern cities, and the other in the summer in the more Northern cities. Thus two meetings were held in the years 1850 and 1851, but no meeting was held in 1852. The large number of members connected with colleges and schools soon made it essential to hold the meetings annually during the summer vacation. In 1859 a meeting was held in Springfield, and in 1860 at Newport. The fifteenth meeting was to have been held in Nashville, but was sus-

pending owing to the unhappy condition of the country. Five years later the meeting was held in Buffalo, when 79 members rallied to revive the meetings which have since that time been annually increasing in importance and have been attended by from 200 to 1000 members according to special circumstances and to locality.

The Association has now about 2000 names on its roll of members, and it has called to its annual meetings the principal societies of a national character, which, largely as offshoots from the Association, hold annual meetings as affiliated societies in connection with the Association. During the existence of the Association there has been on its roll the name of nearly every man and woman of eminence in science in the country, as well as many others equally distinguished in literature and art; while hundreds of men and women have found in the membership of the Association the opportunity of increasing their knowledge by contact with professional workers in science, and have had their minds made broader and their lives more useful as a consequence. The influence of the Association, meeting as it does in various parts of the country, has unquestionably been of the greatest importance to the people in bringing scientific methods and results to their notice; and it is beyond question that many a young mind has been led to pursue a life of scientific research in consequence of incentives derived from these annual gatherings.

The men who have held the position of President since 1848 are such a guarantee of the high character of the Association and the diversity of its interests that it is well to mention the names of Rogers, Redfield, Henry, Bache, Agassiz, Pierce, Dana, Torrey, Hall, Caswell, Alexander, Lea, Barnard, Newberry, Gould, Foster, Hunt, Gray, Smith, Lovering, J. L. LeConte, Hilgard, Newcomb, Marsh, Barker, Morgan, Brush,

Dawson, Young, Lesley, Newton, Morse, Langley, Powell, Mendenhall, Goodale, Prescott, Joseph LeConte, Harkness, Brinton, Morley.

In 1874 the Association was incorporated by a special act of the Legislature of Massachusetts, and it has authority to hold both personal property and real estate. The official home of the Association is in Salem, Mass., where there is an office in charge of the Assistant Secretary, where are kept the publications of the Association and a scientific library of considerable importance. The proceedings of each meeting are published in an octavo volume of several hundred pages, containing the addresses of the President and Vice-Presidents, reports of special committees, and more or less extended abstracts of the two or three hundred papers read at the meeting. Besides the annual volume of proceedings, a quarto number of the memoirs has been published by the generous gift of Mrs. Elizabeth Thompson, the first Patron of the Association. Several volumes of the Association have been reprinted by the liberality of Mrs. Esther Herrman, General William Lilly and Mrs. Thompson, the three Patrons of the Association.

Members of the Association are elected by the Council after nomination by two members of the Association. Upon election members pay \$5 admission fee. There is an annual assessment of \$3 which entitles members to all the privileges of the meetings and to the annual volume of proceedings. From such members as are engaged professionally in scientific work, or have by their labors advanced science in any of its departments, the Council elects the Fellows on nomination from the sections. It is from the Fellows that all officers of the Association are chosen, and thus the management of the Association is kept in the hands of professional scientists, while its doors are open wide to all who are inter-

ested in its objects and wish to be benefited by participation in its meetings.

Any individual who may give \$1000 or more becomes a Patron of the Association. Any member may become a life member by the payment of \$50 at one time which exempts him from the annual assessment. The income of the \$50 is used for current expenses of the Association during the life of the member; afterward the principal is added to the Research Fund. The interest of this fund is devoted to encourage original research. The Research Fund now amounts to nearly \$6000. The first grant from this fund was made at the New York meeting in 1887 to Professors Michelson and Morley to aid them in their important researches for the establishment of a standard of length. From this fund, secured by small savings, the Association has already in eight years been able to make grants amounting to \$2200 in aid of important scientific research. The time will undoubtedly come when this fund will be greatly increased by the Association being made the almoner of patrons of science.

At the present time the Association is divided into nine sections as follows: A. Mathematics and Astronomy; B. Physics; C. Chemistry; D. Mechanical Science and Engineering; E. Geology and Geography; F. Zoölogy; G. Botany; H. Anthropology; I. Economic Science and Statistics. Each of these sections is presided over by a Vice-President of the Association, and each has its secretary and special committees.

During the week of the Association meeting, in any city, two free evening lectures are generally given by the Association complimentary to the citizens. The general sessions, the presidential address and the addresses of the nine vice-presidents, and all the meetings of the sections, are free to all who wish to attend.

The triumphs of science have been many and great. By it mankind has been bene-

fited and civilization advanced. Grand possibilities lead her votaries on in the hope of still greater achievements than any yet accomplished. The diffusion and advancement of scientific knowledge are the objects of the Association for the Advancement of Science.

F. W. PUTNAM.

Permanent Secretary, A. A. A. S.

*BOLOMETRIC INVESTIGATIONS IN THE
INFRA-RED SPECTRUM OF THE SUN.**

WHEN Sir Isaac Newton allowed a beam of light to fall upon a triangular bar of glass, and thus demonstrated the complexity of ordinary light, he undoubtedly rendered science a great service: but when he stopped there, and said that all transparent substances affected light both qualitatively and quantitatively alike, he did it an injury almost as great. The weight of his word deterred investigators and retarded the development of this branch of optics for very many years. At last it was shown that all transparent substances affect light differently. Some bend all the colors considerably out of their course, while scattering or 'dispersing' them but slightly. Others bend, or 'refract,' but slightly, and 'disperse' considerably. In general the violet is 'refracted' most, followed by blue, green, yellow, orange and red, which is refracted least. Similarly, Newton's advocacy of the theory that light is material particles, 'corpuscles,' thrown out from the luminous body, added to the difficulties of gaining a general acceptance of the rival theory, which sees in light only a periodic, or 'wave,' motion, in a hypothetical elastic medium. To-day every scientist accepts the undulatory, or wave, theory of light and is even striving to make it unite the phenomena of light and electricity in one common explanation.

Long after Newton's corpuscles had

* Part of a popular lecture under the auspices of the New York Academy of Sciences.

passed out of science, 'caloric,' or the heat fluid, still maintained its list of respected advocates, and it remained for the first half of this century to relegate 'caloric' to the curiosity shop along with the 'corpuscles.' Then it was that heat was recognized as another manifestation of those periodic disturbances, or waves, in that elastic medium which was then known as the luminiferous ether, and which is now universally referred to as 'the ether.' In 1802 Wollaston, upon repeating Newton's experiment, discovered certain dark bands traversing the colors and apparently separating them. Some ten years later Fraunhofer made these bands the subject of very extensive and careful investigation, observing several hundred and mapping and naming the more important among them. These lines are commonly known now as 'Fraunhofer lines,' and are used as milestones in the spectrum. Thanks to the labors of Wollaston, Fraunhofer, Brewster, Angstrom, Kirchhoff, Bunsen and many others in less degree, we know that a chemical element, as sodium, when its vapor is heated sufficiently, will radiate only certain kinds of light; sodium, yellow; thallium, green; lithium, red, and soon. The light from any white-hot solid, when passed through a prism, is dispersed into a spectrum having all the colors and no dark lines, that is, a 'continuous spectrum.' If we put soda in an alcohol flame it will emit yellow light, which, being sent through a prism, will not give a continuous spectrum, but only a band of yellow at that place where the yellow would come in a continuous spectrum. Now, if the light of a white-hot solid, electric arc-light, for example, be caused to pass through the soda flame and then be dispersed into a spectrum, we shall find the latter to be continuous, except for a dark band at exactly that part of the yellow where the soda flame gave a yellow band. The soda vapor in the alcohol flame absorbed out of the white light just

that kind of light which it can itself radiate. (Kirchhoff's law.) In the spectrum of sunlight we find a Fraunhofer line at just the same point as the dark line occurs when the white light is passed through the soda vapor. The more exact the measurement the more perfect is the coincidence, hence we are compelled to conclude that the light from the white-hot body of the sun has passed through hot soda vapor before it reached our prism; this must have been in the sun's atmosphere, therefore sodium must exist in the sun. The reasoning is analogous and even more convincing that hydrogen with three lines is there, iron with its many hundred, and so of many other of the elements known to us. Some of the Fraunhofer lines do not correspond to any of our elements, but may be identified at any moment, as, for example, those of the recently discovered argon and helium.

The question was soon raised, whether the energy stopped sharply at the red and violet, or extended into the invisible. So-called fluorescent substances soon found something, 'actinism,' beyond the violet, and the thermometer soon found heat beyond the red, and thus began the campaign into the unknown invisible regions of the 'ultra-violet' and the 'infra-red.'

A word as to the size of these little waves and their rapidity of vibration. They are so small that for their measurement a special unit was adopted. The 'micron' (short) is $\frac{1}{1000}$ of a millimeter, or $\frac{1}{25400}$ of an inch, and is usually represented by the Greek letter mu, μ . A 'wave' whose length, including both hill and valley, is $0,75\mu$ ($\frac{75}{25400}$ inch), and which vibrates only about four hundred thousand million times per second, produces the sensation of red in our eyes. If the rate is seven hundred million times per second and the length about $0,43\mu$ ($\frac{43}{25400}$ inch) the sensation will be violet. Between these limits the sensations are the various reds, oranges,

yellow, greens and blues. Beyond these extremes the vibrations have no visible effects upon our eyes.

Photography in the trained hands of Victor Schumann, of Leipzig, has carried the frontier in the ultra-violet out to a wave length of $0,12\mu$, or a distance more than equal to the whole visible spectrum from red to violet. Meanwhile the 'bolometer,' with the consummate manipulation of S. P. Langley, has forced the limits of the infra-red to $10,0\mu$, with good assurances of waves two or three times as long as that, giving us an infra-red spectrum at least twenty times as long as the entire visible one from violet to red.

Metals on being heated increase their resistance to the passage of an electric current; in this fact lies all the secret of success in infra-red spectrometry. Wheatstone devised a system of electrical connections with battery and galvanometer, which compares resistances just as a lever balance compares weights. (See Fig. 1.) Let us

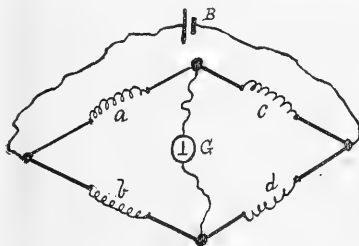

FIG. 1. Diagrammatic representation of the connections of a Wheatstone bridge; *a*, *b*, *c*, *d*, are the four resistances; *B* the battery and *G* the galvanometer.

suppose two very thin strips of metal to be so arranged in a Wheatstone balance (or 'bridge' as it is called) (See Fig. 2); when the adjustment is correct no current will run through the galvanometer, and the beam of light reflected from the little mirror attached to the 'needle' re-

mains stationary. If one of the strips be now warmed, ever so slightly, its resistance will be increased, the balance is destroyed, a current of electricity traverses the galvanometer and the beam of light is deflected from its normal position (zero). The de-

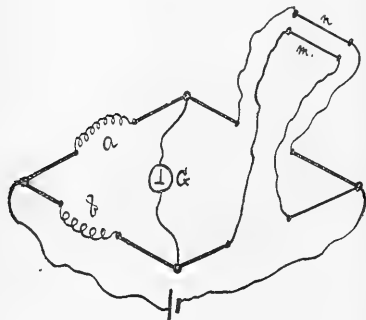

FIG. 2. Diagram of Wheatstone bridge showing how the two resistances c and d are replaced by the 'side arm' n and the 'middle arm' m of the bolometer.

flexion is a measure of the heating of the strip, and the position of the spot of light upon a scale always tells the thermal condition of the strip. Such a pair of strips, fitted with many devices and special adaptations, constitutes a 'bolometer.' One strip, called the 'central arm,' is exposed to the radiations to be measured, while the other, 'side arm,' is carefully shielded therefrom. The exposed strip of a bolometer for spectrum work is about 8 mm. long, $\frac{1}{10}$ mm. wide, and $\frac{1}{200}$ mm. thick ($\frac{1}{3} \times \frac{1}{100} \times \frac{1}{200}$ inch) appearing like a fine hair. Of course the galvanometer is the most delicate, and all precautions are taken. Such a system will record a rise in temperature of one of its strips of less than $\frac{1}{100000}$ of a degree centigrade ($\frac{1}{800000}$ Fh.)

Professor Langley's pioneer work into the infra-red regions of the spectrum was all by visual observations with the bolom-

eter. Let us suppose that some invisible Fraunhofer line is to be located. A large clockwork arranged to rotate a mirror is so adjusted that it reflects a beam of sunlight upon the slit of the spectrometer, which then gives a distinct spectrum, with its lines visible and invisible. The bolometer, mounted upon the arm of the spectrometer, is so set that its central arm coincides with some visible Fraunhofer line, and the circle of the spectrometer is read. This is the starting point. The arm is then turned until the bolometer stands where a line is sought. Again the circle is read. The slit of the spectrometer is then closed and the position of the spot of light at the galvanometer is noted. The slit is opened and the galvanometer read, then the slit is closed and the galvanometer read. The average of the first and third galvanometer readings subtracted from the second gives the deflection due to the radiant energy falling upon the bolometer at that particular point in the invisible infrared spectrum of the sun. The arm is now moved forward a little, bringing the bolometer into a new part of the spectrum. Again a series of deflections are read and the energy measured. Thus hundreds and thousands of points in the spectrum are determined, and these, when plotted, show the deep valleys where the energy runs low and the hills where it is abundant. In this way Professor Langley and his assistants, with consummate patience and perseverance, felt over the long stretches of the infra-red, mapping a beautiful 'energy curve,' with its many little notches and its four or five huge valleys separated by high peaks.

Some time after Prof. Langley's advent in Washington he organized an astrophysical observatory and in it has prosecuted his investigations by a new method and with renewed enthusiasm. The essential principles of the operation remain the same,

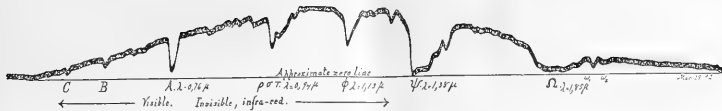

FIG. 3. One of the first bolographs, made in six minutes. A curve where the abscissae depend upon the wave-lengths of the undulations; and each ordinate is the amount of energy of the wave-length represented by the corresponding abscissa. C, B and A are the visible Fraunhofer lines; $\rho\sigma\tau$, ϕ , ψ , Ω , and $\omega_1 \omega_2$ are absorption bands in the infra-red. λ stands for wave-length.

only the record is automatic. The spot of light reflected from the mirror of the galvanometer no longer falls upon a scale, but upon a photographic plate which is raised or lowered by a clockwork. The same mechanism drives the tangent screw of the spectrometer, thus slowly swinging the bolometer through the spectrum. Now the operation is as follows: When all the adjustments have been made, the reading of the circle is noted at the starting point. At the signal the slit is opened, and a few seconds later the clockwork is set in motion, swinging the arm and lifting the plate. So long as the bolometer receives the same quantity of energy the spot of light remains stationary and traces a vertical line upon the rising plate. If the bolometer encounters an absorption band it cools off and the spot of light moves to one side, making a break in the trace. If it encounters a warm region the deflection will be in the opposite direction, and so on. The bolometer strip, as it sweeps through the darkness beyond the red, traverses regions varying in their quantities of heat, and continually reports its condition by the deflections of the spot of light, which is recorded in an irregular line upon the plate until at the signal everything stops, and in ten minutes an energy curve has been traced, better in nearly every respect than Prof. Langley's first one, which represents thousands of tedious observations. (See Fig. 3.) By this method, in a few hours of good work, curves are obtained which show hundreds of lines where dozens were intimated before. (See Figs. 4

and 5.) One must have seen it to appreciate the fascination of watching that simple spot of light and seeing in one's thoughts that little strip climbing up the heights of energy mountains only to plunge

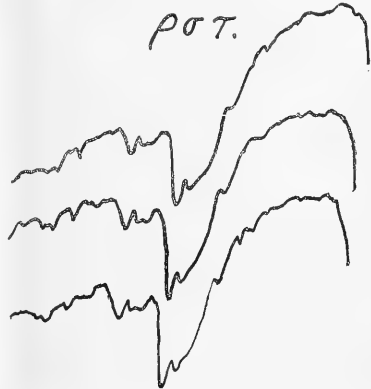

FIG. 4. Three bolographs of the infra-red group $\rho\sigma\tau$ showing how well different records agree, even in detail.

into a cold abyss upon the other side, absolutely unerring, overlooking no trifling hillock, overestimating no lofty peak.

When desired, such energy curves can be converted into 'line-spectra,' similar to the photographs of the visible Fraunhofer lines. Such a line-spectrum, combined with Schumann's photographs of the ultra-violet and Rowland's of the visible spectrum, upon Rowland's scale, would give us a radiant energy spectrum about six hundred feet long.

Of what use is all this? Could Faraday foresee that Morse would invent the telegraph or Bell the telephone? Could Helmholtz or König foresee the phonograph? Fortunately we live at a time when any addition to the world's knowledge of nature's truths is sufficient justification for any investigation however laborious.

The bolometer has already taught us that the firefly is a dozen times more economical as a light producer than our best electric



FIG. 5. A bolograph of the sodium double yellow line indicating the nickel line between them. This will show the extreme delicacy of this method of feeling and recording absorption lines.

lights and a hundred times better than our gas. It has taught us that our atmosphere acts like a valve, transmitting in almost undiminished strength the short quick waves of energy radiated to us from the sun, but refusing absolutely to return the long slow waves in which the earth tries to radiate the energy back into space. Without this atmosphere we should all have been frozen long ago.

We now know of electric waves which behave in every respect similarly to those of light, but which are many times longer and slower. Almost every month brings the announcement of shorter and faster electric waves, while Prof. Langley and his fellow laborers are continually detecting longer and slower light waves. Thus the bound-

aries of our knowledge are forced forward, and the unexplored strip becomes ever narrower. Light is as it were the snowy cap of a mountain. One explorer pushes downward from the light top into the dark regions lying below, while another from the broad and fertile valley of electricity struggles upward into the unknown. Are the two upon the same mountain? Will they ever meet? We hope so, we believe so, but until they have clasped hands we are not satisfied. Other workers may be found to be upon the same ether mountain, gravitation and other mysteries may there find a solution. What is above our mountain, unencumbered ether? thought? life?

WILLIAM HALLOCK.

COLUMBIA COLLEGE.

VERTEBRATE PALEONTOLOGY IN THE AMERICAN MUSEUM.

THE American Museum of Natural History has recently acquired the collection of fossil mammals, made by Professor Cope between 1872 and 1895. The collection represents eleven geological horizons, including specimens from the Jurassic, Laramie (Cretaceous), Puerco, Wasatch, Wind River, Bridger, Washakie, White River, John Day, Loup Fork and Pleistocene. The collections from the John Day and Wasatch of New Mexico and Wyoming are exceptionally perfect, and that from the Puerco, together with the collection already in the Museum procured by the expedition of 1892, is unique. Four hundred and seventy species are represented, of which four hundred and two are types. The collection is representative of all of Professor Cope's researches upon the mammalia, with the exception of the greater portion of his work upon the Wheeler Survey, the types of which are contained in the Smithsonian Institution of Washington, and more recently of his work upon the Canadian and Texas Surveys. The most complete speci-

mens are the skeletons of *Hyracotherium* and *Phenacodus* from the Wasatch and of *Hyrachyus* from the Bridger. There are also skeletons of *Galecynus* and *Trispondylus*, and material for the restoration of several other animals. Professor Cope has reserved the right of describing the new material, but the entire collection will be arranged and placed on exhibition as rapidly as possible, and will be permanently known as the Cope Collection. A large new storeroom on the upper floor of the new wing of the Museum has been set apart especially for it. All the specimens will be numbered; the types designated under the direction of Professor Cope, and all information regarding localities, dates, description, etc., will be entered on a special card catalogue. The collection will thus be made readily accessible to students.

The Exhibition Hall on the third floor of the new wing of the American Museum has been designed and cased for the entire collection of fossil mammals, and will be opened for exhibition in November. The line of large cases on either side of the centre of the hall is designed for complete mounts of *Aceratherium*, *Metamynodon*, *Palaeosyops* and *Titanotherium* and other animals now in preparation. The smaller side cases will contain morphological exhibits of the evolution of members of the families; also cases arranged geologically to represent the faunæ of each horizon; and a series of upright A cases designed for the exhibits of the evolution of the teeth, feet, skull and other special parts of the skeleton.

The expedition of 1895, the fourth which has been sent out, entered the Uinta beds early in the spring and explored the three levels in which the Uinta deposits are divided, as late as the water supply admitted. The party was then reinforced by a photographer, and, under the direction of Dr. Wortman, moved north to the southern exposure of the Washakie basin, east of the

Green River, and is now working in the *Uintatherium cornutum* beds with considerable success. The work of these expeditions is not confined to the collections of fossil mammals, but to the careful survey of the successive depositions in these various basins. Every basin visited is explored with the greatest care to determine the vertical succession and horizontal distribution of species. The main result of this exploration is to prove that each of the larger subdivisions of Leidy, Cope and Marsh is capable of being divided into a number of successive stratifications or beds, distinguished by characteristic species. The application of this method was begun by the Princeton expedition of 1880 in the surveys of Professor McMaster, but unfortunately was not followed up with sufficient care. Several years ago Mr. J. B. Hatcher showed that the lower portion of the White River beds was capable of subdivision into three clearly defined levels, and the American Museum party of 1893-94 proved that above the *Titanotherium* beds five other specific levels could be determined, thus dividing the White River beds into eight levels. In 1894 the Uinta beds were proved to be distinctly divided into three levels, the older of which overlaps the somewhat older Washakie beds, and the uppermost overlaps the beds of the more recent White River beds, thus demonstrating that the Uinta is the complete link between the Middle Eocene and the Lower Miocene or Oligocene. This summer the party is endeavoring to determine the exact relations of the Washakie depositions to the somewhat older Bridger deposition west of the Green River.

HENRY F. OSBORN.

THE GEOGRAPHICAL DISTRIBUTION OF THE
MOLLUSCA.

WE hear a great deal of late concerning the habits, range of variation, and special characteristics of a great number of forms

of life; but very little is written concerning the methods by which species peculiar to one locality may be transported to others many miles distant. This is a subject which bears more closely on the origin of species than any other, and one which will yield some of the best results, if studied carefully and faithfully, and if original observations are made in the field. It is my purpose in this communication to briefly consider some of these transporting agencies as illustrated by the Mollusca, from facts gathered by myself while collecting in the field, and from reliable correspondence.

Distribution by the aid of birds.—Several years ago, while on a collecting trip to Florida, I took occasion to dissect several hundred migrant and resident birds and to carefully note the contents of their crops. In a large number of the crops I found the shells of mollusks which had been taken as food; these shells were mostly minute, and of the genera *Pupa*, *Ampicula*, *Pisidium* and *Vertigo*. These shells, being indigestible, and not affected by the gastric juices of the stomach, would naturally pass off with the feces. In this manner, the shells of many species of mollusks, which were once supposed to inhabit restricted localities, have been found at a great distance from their recorded habitats. Especially would this be true during the migratory season, when a bird would swallow a species in one State and drop the shell with the feces in another. The shells, of course, would in most cases be dead when dropped, the animal portion being used as food; but there are exceptions to this, for I have several authentic accounts of living mollusks being found in the stomachs of birds. As an example of the wide distribution of these small mollusks, I cite *Pupa armifera*, Say, which is found from Dakota and Kansas to the Eastern States and Mexico.

The Catbird (*Galeoscoptes carolinensis*) I found to feed only (so far as the Mollusca

were concerned) on the minute land snails *Pupa* and *Vertigo*. It was frequently observed on the palmetto trees searching for these minute animals. The hawks and kites of Florida, especially the Everglade Kite, seemed to consider the animal of *Ampullaria depressa*, Say, a great delicacy, for in almost every crop dissected I found the remains of this mollusk. Heaps of the dead shells of this animal were always found beneath their roosting places. Frequently a hawk or kite will capture this fresh-water snail and carry it several miles to its roosting place; but many times another bird will overtake the one carrying the booty, and a dispute of ownership will follow, which nearly always results in the loss of the prey, which drops unharmed, perchance, into a pond which this species has not before inhabited, and there, if laden with eggs, as is frequently the case, establishes a new colony of *Ampullaria*. By this means, as well as others, this species has been distributed over a great portion of Florida. It is my belief that many a colony of mollusks, as well as other animals, has been formed in this manner.

Ducks, geese, swans and many other kinds of wild fowl, are very fond of snails, and I have never failed to find the remains of them in their crops. By means of these birds the shells of many mollusks have been transported for many miles, and have offered, doubtless, material over which some conchologist has worried and finally described them as a new species! I know of several instances where the eggs of a mollusk were found attached to the foot of a mallard, and several birds have come under my notice, which, when shot, had young Anodons and Sphæriums adhering to their toes. Many other instances might be cited of this character, but enough has been said to show that birds exert a wide influence in the distribution of the mollusca.

Distribution by the aid of fishes.—Various

species of fish feed upon snails as a regular diet. After feeding in one spot they repair in schools to some particular spot, often many miles distant from the feeding ground, where they digest the animal and eject the shell, either through the mouth or with the feces. In this manner littoral mollusks are carried to the abyssal regions, and, I believe, have been described as deep-sea forms. The greater portion of the foregoing accounts relate only to the dead shells which have been ejected from the stomach of some vertebrate animal, and the change cannot be said to be a correct variation in habitat, save in the few cases cited where the living animal was transported; it is simply the dispersal of a skeleton from one point to another.

Dispersal of the living animal by means of insects.—It would hardly be supposed that insects could in any way be the means of distributing mollusks, and yet I have numerous records of such distribution. Some time ago a water beetle was captured, which had a *Sphaerium* attached to one of its legs; another species was captured with an *Ancylus* attached to its wingcase. I have records of other instances where the larger water beetles had specimens of *Physa*, *Planorbis*, and even *Limnæa* attached to different portions of them. In this manner living mollusks have been transported from one pond to another, and so many of the fresh-water species have been distributed by the humble means of a water beetle.

Distribution by means of storms, ocean currents, etc.—We may now consider a change of habitat which affects the living animal more closely than in the cases previously cited. Many portions of Florida bordering the rivers and creeks are continually falling away and being carried into the Gulf, and so to Cuba, Yucatan and other parts of the West Indies and Mexico. These transported masses consist of three trunks, entwined vines, branches and roots of trees

covered with earth and vegetation. Many times, during storms, whole tracts of land are washed away and portions of them of considerable size are carried many miles by the currents. Upon all of these natural rafts, mollusks are found which are transported to habitats a great many miles from those in which they first appeared. In this manner *Helices*, *Bulimi*, *Pupæ*, *Limnæa*, *Physa*, *Planorbis*, and a host of species too numerous to mention, are carried from the Southern States to Cuba, Mexico and Yucatan. No doubt many of the species of land and fresh-water shells found in Cuba which are also found in the Southern States, especially Florida, were carried there in this manner, or were carried from Cuba to the States.

In the Western States fresh-water and land shells are continually being carried from one point to another. In the early spring, when freshets and floods occur, the young fry, as well as the adult animals, are carried from the headwaters of the Mississippi River to various places along its banks upon driftwood, tree trunks and an innumerable number of natural rafts of this character. In this manner the species of *Unio* have reached a comparatively wide distribution. So also in our Great Lakes the fry of mollusks are carried from Huron to Ontario. Mountain streams, during freshets, are potent vehicles of transportation in the spring, and no doubt many mollusks living at high altitudes are carried by this means from the mountains to the valleys and plains below. As an example of this I cite the following case, furnished by a reliable correspondent: About two years ago a colony of *Vittrina limpida* was found in a Pennsylvania town just after a severe flood; the species had not been before observed, although the collector had searched the locality for several years preceding. These shells had undoubtedly been brought down the Alleghany River on rafts during the flood, and the little colony

had been formed. From last accounts the little colony was doing well. This is but one example of many which prove that mollusks are distributed in this manner. I have one authentic case of a number of Anodons being carried away by a whirlwind and falling several miles distant during a severe rainstorm.

Distribution by human agencies. Man has been a great factor in the distribution of all animal and vegetal life, and the Mollusca are no exception to the rule. The great Erie Canal has been a powerful transporting agent. In it we find species of *Physa*, *Limnaea* and *Planorbis*, which were once supposed to inhabit only the western lakes and rivers. Even European species, like the giant *Limnaea stagnalis*, have been brought over from Germany and France, and are now found from Illinois to New York; so also with several small Valvatas and Amnicolas. Land mollusks have also been brought from Europe, either adult or in the egg, and we now have several colonies of *Helix nemoralis* and *H. hortensis* in several parts of the United States. In the City of Mexico, in a little corner of the cypress grove at Chapultepec, is a large colony of *Helix aspersa*, which, up to the time of its discovery, in 1890, was not supposed to be found in Central America. It is now spreading over the valley of Anahuac, and will before long be a recognized part of the fauna of Mexico. This species was undoubtedly brought to Mexico with German goods, found a locality favorable to its existence, and has grown and multiplied. This same species is now found in Charleston, South Carolina; New Orleans, Louisiana; Portland, Maine; Nova Scotia; Santa Barbara, California; Hayti; Chili; etc. It is a curious fact that *Helix hortensis* was not accidentally introduced into the country, as were *H. nemoralis* and *H. aspersa*, but was first brought to Burlington, New Jersey, by Mr. W. G. Binney. This species does not

thrive so well, nor does it spread so rapidly, as did the other species mentioned.

Our large garden-slugs, *Limax maximus* and *L. agrestis*, were introduced into this country some fifty years ago, and are now found all over the northeastern part of the United States and parts of Canada. The transportation of hothouse plants has been the principal means of distributing these species, for they are found more abundantly in greenhouses than in any other locality. Geological changes also tend to disperse mollusks and also to change their mode of living. A single example will suffice to illustrate this point. In Africa there is a lake (Lake Tanganyika) in which live a number of mollusks almost identical in the form of the shell and animal with the marine group of shells known as Trochids; yet these mollusks live in fresh water and have the principal characteristics of fresh-water species. Now this lake must at some time have been connected with the sea, and the change from salt to fresh water must have been very gradual in order not to have killed off all the animals. Numbers must have died during the change, and those that were the most enduring lived and multiplied. The result of the change is some of the most curious mollusks known to science. (*Limnotrochus*, *Tiphobia*, *Neuthauma*, *Tanganyicia*, etc.)

And thus I might go on and give hundreds of examples of the distribution of mollusks by natural and artificial methods; but I believe I have given enough to illustrate my point, which is that there is nothing so very wonderful in the finding of species hundreds of miles from their supposed natural habitat, and that the apparent 'paradox' of their discovery can be accounted for by some one of the examples given above. More attention should be given to the careful recording of facts such as those I have given, which are to my

mind far more valuable to science than the indiscriminate description of new species and genera, and a multitude of such facts would aid very materially in the solution of the origin of species, and the reasons for the gradual change from one type to another.

FRANK C. BAKER.

THE CHICAGO ACADEMY OF SCIENCES.

CURRENT PROBLEMS IN PLANT MORPHOLOGY (I.)

THE QUESTION OF PTERIDOPHYTE PHYLOGENY.

IF the question be asked: which among living genera of Pteridophytes most closely resembles the hypothetical archetype, three answers are at hand. Goebel, of Munich, adheres to the Prantlian theory that *Hymenophyllum* of the leptosporangiate ferns may be regarded as primitive. The peculiar strength of this position lies in the apparent homologies between the filamentous prothallia of this fern and moss-protonema such as that in particular of *Buxbaumia*. Bower, of Glasgow, has brought forward for consideration the curious club moss *Phylloglossum* and constructs, under his strobilar hypothesis, a phylogeny passing from Lycopodiaceæ through the eusporangiate ferns to the leptosporangiate, practically an inversion of the older view. Campbell, of Leland Stanford, has argued ably the claims of the eusporangiate fern *Ophioglossum*, deriving from its region the Marattiaceæ, Isoetaceæ, Lycopodiaceæ and leptosporangiate series of ferns.

The three views may really be reduced to two; Goebel maintains a leptosporangiate origin for the group; Bower and Campbell would establish an eusporangiate origin. Therefore one view is quite exactly the converse of the other. The peculiar strength of the new position lies in the remarkable sporophytic homologies which have been indicated between *Anthoceros* of the Hepaticæ and *Marattia* and *Lycopodium*.

At present the German school labors

under a certain disadvantage, although the position of Dr. K. Goebel is in accord with the new ideas of mechanomorphosis developed in the rough long ago by Sachs and De Bary and lately carried forward by Sachs, and among zoölogists by Roux, Driesch and many others. The disadvantage consists in a necessary opposition to the well-established hypotheses of differentiation, an opposition in which an actual metamorphosis of embryonic rudiments (*Anlagen*) is maintained. Bower's theory of sterilization, than which nothing could seem more reasonable under the generally accepted interpretations of ontogenetic and paleontologic records, must be set aside, and, finally, little use can be made of the remarkable pteridophytic characters of the *Anthoceros* and *Notothylas* sporophytes; but one must turn away from this group and bring forward the more specialized mosses as archetypal plants.

Hugo Glück, in *Flora* 80: 303-387, 1895, under the title *Die Sporophyll Metamorphose*, gives a valuable census of anatomical resemblances between sporophylls and foliage leaves, and after an examination of sporangial protective apparatus, viz., hairs, pits, indusia, rolled-over margins, etc., of sporophyll petioles, and of various transitional forms, proposes as established the thesis that 'all sporophylls are metamorphosed foliage leaves.' This is almost exactly the converse of the Bower-Campbell position which maintains the derivation of non-sporangium-bearing leaves from a sporangial tract. The argument of Glück is by no means convincing, for his evidence, apparently, might be used with quite as much force on the other side.

Goebel, carrying the war into Africa, brings out a paper entitled '*On Metamorphosis in Plants*' in *Science Progress* 3: 114-126, 1895, which expresses his views tersely and clearly. The outcome of the debate is interesting, for it promises to resolve itself

into a struggle between the older evolutionary and the newer developmental mechanical interpretations of morphology. It is difficult to see how the Bower sterilization theory can be overturned without carrying with it the whole scheme of Archeogoniate phylogeny which plant morphology owes to the classic work of Hofmeister. Nothing can be more apparent under accepted beliefs than that from *Oedogonium* sporophytes upward there is a progressive change from an entirely sporogenous plant body to one in which the great part of the sporogenous tissue is replaced by sterilized areas. It is, however, possible that both differentiation and the 'true metamorphosis' of Goebel have gone on together in the phylogenetic series. The experimental method would doubtless throw more light on the whole matter than the speculative phosphorescence which, up to the present, has been the chief illumination.

CONWAY MACMILLAN.

SCIENTIFIC NOTES AND NEWS.

AUSTRALASIAN ASSOCIATION FOR THE ADVANCEMENT OF SCIENCE.

THE Seventh Session of the above Association will be held in Sydney, from the 3rd to the 10th January, 1897, under the Presidency of A. Liversidge, M. A., F. R. S., Professor of Chemistry, University of Sydney.

The Presidents and Secretaries of the Sections are as follows:

Astronomy, Mathematics and Physics.—R. L. J. Ellery, C. M. G., F. R. S., Government Astronomer, Vict., President; R. Threlfall, M. A., Professor of Physics, and J. Arthur Pollock, B. Sc., Demonstrator in Physics, Sydney University, Secretaries.

Chemistry.—T. C. Cloud, A. R. S. M., F. G. S., Manager Wallaroo Copper Works, South Australia, President; W. M. Hamlet, F. C. S., F. I. C., Government Analyst, N. S. W., Secretary.

Geology and Mineralogy.—Captain F. W. Hutton, M. A., F. R. S., F. G. S., Director of Canterbury Museum and Lecturer in Geology, Christ Church, New Zealand, President; T. W. E. David, B. A., F. G. S., Professor of Geology and Physical Geography, Sydney University, and E. F. Pittman, A. R. S. M., F. G. S., L. S., Government Geologist and Lecturer in Mining, Sydney University, Secretaries.

Biology.—T. J. Parker, B. Sc., F. R. S., Professor of Biology, Otago University, Dunedin, New Zealand, President; W. A. Haswell, M. A., D. Sc., F. L. S., Professor of Biology, Sydney University, and J. H. Maiden, F. C. S., F. L. S., Curator, Technological Museum, Sydney, and Superintendent of Technical Education, N. S. W., Secretaries.

Geography.—H. S. W. Crummer, Secretary of the Royal Geographical Society of Australasia, N. S. W. Branch, Secretary.

Ethnology and Anthropology.—A. W. Howitt, F. G. S., Secretary for Mines, Vict., President; John Fraser, B. A., LL. D., Sydney, Secretary.

Economic Science and Agriculture.—R. M. Johnston, F. L. S., Government Statistician, Tasmania, President; Walter Scott, M. A., Professor of Greek, Sydney University, and F. B. Guthrie, F. C. S., Consulting Chemist to the Department of Agriculture, N. S. W., Secretaries.

Engineering and Architecture.—H. C. Stanley, M. I. C. E., Chief Engineer, Southern and Western Railway Lines, Queensland, President; J. W. Grimshaw, M. Inst. C. E., M. I. Mech. E., &c., Supervising Engineer, Harbors and Rivers Department, N. S. W., Secretary.

Sanitary Science and Hygiene.—Hon. Allan Campbell, M. L. C., L. R. C. O., South Australia, President; J. Ashburton Thompson, M. D., Chief Medical Inspector, Board of Health, N. S. W., Secretary.

Mental Science and Education.—John Shir-

ley, B. Sc., District Inspector of Schools, Brisbane, Queensland, President; Francis Anderson, M. A., Professor of Logic and Mental Philosophy, Sydney University, Secretary.

Communications and papers for the meeting, or inquiries, may be addressed to the Permanent Hon. Secretary, The Chemical Laboratory, The University, Sydney, N. S. W.

THE GEOLOGICAL SOCIETY OF AMERICA.

THE seventh summer meeting of this Society will be held Tuesday and Wednesday, August 27th and 28th, in the Art Museum, Springfield, Mass. The Council will meet Monday evening, August 26th, and the Society will be called to order on Tuesday morning at 10 o'clock. The preliminary list issued on July 30th includes papers by George M. Dawson and R. G. McConnell, C. H. Hitchcock, Warren Upham, H. L. Fairchild, B. K. Emerson, N. H. Darton, Arthur Hollick, George P. Merrill, Wm. H. Hobbs, A. Capen Gill, C. H. Gordon, J. F. Kemp, J. C. Branner, W. M. Davis, C. R. Van Hise. The excursions arranged include one of a week, beginning Tuesday, August 20th, through the crystalline area of western Massachusetts conducted by Professors B. K. Emerson and Wm. H. Hobbs, and three shorter excursions during the week of the meeting: (1) To the crystalline rocks west of the Connecticut River, under the direction of Prof. W. O. Crosby. (2) To the Triassic sandstones, including a visit to Mount Tom and Mount Holyoke, under the direction of Professor B. K. Emerson. (3) To Meriden and Southington, Conn., under the direction of Professors W. M. Davis and William North Rice.

THE WORK OF YALE OBSERVATORY.

IN the report for the year 1894-5 presented by the board of managers of Yale University to the President and Fellows,

Dr. Elkin states that he has continued and brought to what he hopes is a final close the series on the parallaxes of the first magnitude stars, and hopes to present the definitive results in the near future. The series on the parallaxes of the large proper motion stars, on which Dr. Chase has been mainly engaged, now comprises 99 stars, all but two of which have been observed at two parallax maximum epochs, in general on three nights. Measures of the Moon's diameter at the total eclipse of March 25th, last, and measures of Mercury referred to the Sun's limb at the transit on November 10th, last, were attempted, but in both cases the state of the sky permitted our obtaining only a small amount of results. The reductions of the *Coma Berenices* triangulation have been practically completed, and the work will shortly be ready for the press. The new equatorial mounting constructed by Warner & Swasey for carrying a number of cameras was used on three nights of the August meteor period, but only two meteor trails were found on the plates. The observatory has, however, twelve impressions of Perseid trails, and plates showing meteor trails have been sent by Professor Barnard and Professor Pickering, a discussion of which Dr. Elkin will shortly have ready for publication.

GENERAL.

It is hoped that Professor W. M. Davis will give one of the lectures on the part of the American Association complimentary to the citizens of Springfield. In this case his lecture would be upon the geographical development of the Connecticut Valley and would be illustrated by lantern pictures. The other lecture will probably be by Mr. Cornelius Van Brunt, on the Wild Flowers of the Connecticut Valley, illustrated by colored lantern pictures of the flowers and plants. The local committee contemplate offering a room free of

expense for the exhibition of scientific apparatus, specimens, etc. The railroads generally are making reductions on the plan of one rate and a third for the round trip, but unfortunately no reductions have as yet been made for railroads west of the Mississippi. Members from the West can, however, secure the reduction from points east of the Mississippi.

A CIRCULAR issued by Mr. William Kent, Vice President, and Prof. Harold S. Jacoby, Secretary of the Section of Mechanical Science and Engineering of the A. A. S., recommends that the papers read before the Section relate more especially to the application of scientific methods to the various engineering problems, while the more strictly technical subjects and the description of finished projects which appeal only to one branch of engineers belong rather to the different engineering societies. It has been suggested that short papers be presented giving information regarding the following questions: Have you any experimental data which either confirm or throw doubt upon formulas or constants hitherto generally received? Have you any data upon subjects hitherto considered doubtful, as, for example, the strength of unstayed surfaces? What subjects should engineering laboratories undertake to investigate, with a view to obtaining data which will be of general importance, and how would you propose to make such tests (including a description of the apparatus)? It is hoped that many brief resumé's of investigations or experiments relating to different subjects of interest to the Section may be offered for this meeting.

It was announced in the preliminary circular of the A. A. S. that the State Weather Service Association would meet in Springfield, Mass., but it is now found impracticable to meet with the A. A. S., on account of the difficulty in securing representation of the various State services,

three of the four preceding State Weather Service Conventions having been held in Eastern cities. Indianapolis, Ind., has therefore been selected for the place of meeting this year, and a large attendance of State Weather Service Directors is promised. The convention will be held October 15th and 16th.

THE Linnæan Society of New York has published the abstract of its proceedings for the year ending March 26, 1895. There were held during the year 14 meetings of the Society, at which the average attendance of members was seven and of visitors six. There were read 16 papers, of which nine related to ornithology and the remainder chiefly to mammology. The officers elected for the ensuing year are: President, J. A. Allen; Vice-President, Frank M. Chapman; Secretary, Walter W. Granger, and Treasurer, L. S. Foster. There are appended to the proceedings two papers, one by Dr. Juan Gunlach, entitled 'Notes on Cuban Mammals,' and one by Mr. W. L. Sherwood, on 'Salamanders found in the Vicinity of New York City, with Notes upon Extra-limital or Allied Species.'

PROFESSOR MENDELÉEFF will visit London during the present month, in connection with the work of making standards of Russian weights and measures.

IN England Mr. James Blyth, the well-known agriculturist, has received a baronetcy, and Mr. Herbert Gardner, President of the Board of Agriculture, has been made a peer.

A STATUE of M. Boussingault has been erected in the Court of the Conservatoire des Arts et Métres in Paris, in which institution he was professor of agricultural chemistry for forty years.

THE *Medical Record* states that The Charcot Monument Fund now amounts to over 40,000 francs, nearly half of which sum has been contributed by foreigners.

It is proposed to commemorate the fiftieth anniversary of Professor Leuckart's doctorate. American students who have studied zoölogy under Professor Leuckart at Leipzig and who wish to contribute to the memorial—which will be a marble bust—should send subscriptions to Herrn Karl Graubner, Johannes Gasse 8, Leipzig.

SIR JOSEPH LISTER has been presented with a portrait of himself painted by Mr. Lorimer as a testimonial from his colleagues and pupils on his retirement from his chair in King's College Hospital. Speeches were made by Dr. W. S. Playfair, who presided, and Sir John Ericksen.

It is proposed to erect a statue in Copenhagen to the memory of Dr. Hans Wilhelm Meyer. Subscriptions may be sent to Mr. A. E. Cumberbatch, 80 Portland Place, London, W.

THE citizens of Geneva have petitioned that the statue of Carl Vogt, the work of M. de Niederhausen, be placed in the open air on the Promenade des Bastions instead of in The Vestibule of the University.

SIR WILLIAM FLOWER, Professor W. Ramsay and M. Sabatier have been elected correspondents of the French Academy.

The *Photographic Times* for August contains an admirably illustrated article on Astronomical Photography by Professor E. E. Barnard. A number of full-page reproductions are given of photographs with exposures as long as five hours.

We quote from the *Lancet* the outlines of a plan having for its object the continuation of the Index Medicus: "The yearly cost of production is about £1,000 and it is proposed to raise this sum by 200 subscriptions of £5 each. The United States, it is estimated, will supply 120, Great Britain 60, and the Continent 20. We think, however, that Great Britain with all her learned societies might well subscribe £400 by herself. If £5 is too heavy a tax for one indi-

vidual to undertake, there are surely five medical men in every one of our large towns each of whom would subscribe £1, and so form a group which would receive a copy of the Index for their common use; while institutions and societies should have no hesitation in voting the required amount. Those who are willing to subscribe are requested to communicate with the Librarian, Royal Medical and Chirurgical Society, 20 Hanover Square, London, W."

At a recent meeting of the Michigan State Board of Health, the means of carrying out a new act of the Legislature passed at the instance of the board were discussed. This act requires the State Board of Health annually to send to public school superintendents and teachers throughout the State, printed data and statements which will enable teachers to teach their pupils the modes by which the dangerous communicable diseases are spread, and the best methods for the restriction and prevention of such diseases. This same law provides a fine or forfeiture in cases where any school board wilfully neglects to comply, and such neglect by any superintendent or teacher is sufficient cause for dismissal. There are 16,000 teachers in the State who will be required to spread sanitary information to their pupils. From a better and more general knowledge of diphtheria alone it is hoped that there will be a saving of life and money values equal to an amount much greater than the State now expends for the maintenance of the State Board of Health.

THE International Congress of Otolaryngology, held at Florence on September 23rd, will be attended by the leading aural surgeons of Europe and America. The last congress was held in Brussels in 1888.

PROFESSOR J. MARK BALDWIN, of Princeton, is coöperating in the preparation of the new French *Dictionnaire de Physiologie*, of which Professor Ch. Richet is the general

editor. Among the more important topics assigned to Professor Baldwin are *Intelligence* and *Heredity*.

THE question whether a child is naturally moral or immoral will be taken up by Professor James Sully in *The Popular Science Monthly* for September. This article will be devoted to primitive egoism and altruism, and will show that many of a child's acts that seem perverse or cruel are explained when we try to look at things from the child's personal standpoint.

THE first number of the American Journal of Sociology has been issued from the press of the University of Chicago under the editorship of Professor Albion W. Small. The number opens with an editorial article entitled 'The Era of Sociology,' followed by an article on 'The Place of Sociology Among the Sciences' by Lester F. Ward. The other articles are contributed by members of the University of Chicago.

SIR JOHN TOMES, a distinguished dental surgeon and writer on dental anatomy, died at Caterham, England, on July 29th. He was born at Weston-on-Avon in 1815. In addition to a large number of scientific papers he published in 1848 a 'Dental Physiology and Surgery' and in 1859 'A System of Dental Surgery.' In its latest edition the latter work is regarded in England as the standard text-book on the subject.

JOSEPH DERENBOURG, professor of oriental languages at the École Pratique, died at Paris on August 5th in his 84th year.

DR. GEORGE STEVENS, professor of English language and literature in the University of Copenhagen, died in Copenhagen on August 9th at the age of 82 years. He is known for his writings on history, folklore, linguistics and runology.

DR. VON GNEIST, professor of jurisprudence in the University of Berlin, died on July 21st, at the age of 79.

CORRESPONDENCE.

CAUSES OF THE GULF STREAM.

I AM convinced that one of the most important functions of such a journal as SCIENCE is the friendly criticism of articles whether appearing in its own pages or in those of other journals. Much harm is done by allowing to go unchallenged even slight inaccuracies in scientific statements. Permit me then to draw attention to some such inaccuracies in our issue of July 26th.

1. In Mr. R. Meade Bache's excellent article on the 'Causes of the Gulf Stream,' which I have read with the greatest interest and satisfaction, on page 89, 2d column, in speaking of these causes the writer says: "One of these, the centrifugal force of the earth's rotation, *draws the water as a submarine flow* from the poles to the equator." And again on page 92 he criticises Carpenter for omitting 'this agency of rotation.' Now, to say the least, this is an inaccurate mode of statement. For on the equilibrium theory, which he is sustaining, the only force which determines the exchange between poles and equator is difference of density. Rotation cannot *generate*, but only *deflect* a current already generated by some other cause. Centrifugal force determines the form of equilibrium, but does not disturb the equilibrium, and therefore cannot generate a current.

2. Again, on pp. 92 and 93, he says: "Both the Northern connecting current and the Southern connecting current run for the greater portion of their course *due east*, and therefore the direction of their courses is not, for that portion of their journey, influenced (deflected) by the rotation of the earth." Here we have again the very common but wholly false idea that deflection by rotation takes place only in bodies moving northward or southward. The fact is, the deflection is a function of latitude, but wholly *independent of the direction of motion*.

A current or a projectile or a Foucault pendulum is equally deflected whatever be the direction of motion. The deflection is always to the right in the northern hemisphere and to the left in the southern. An eastward going current in both hemispheres is deflected toward the equator.

THE NATURE OF VOWELS.

MY next criticism is of a statement contained in article taken from the *London Times*. This, of course, is not an authoritative source, but since it reappears in SCIENCE it ought not to go unchallenged.

Speaking of the use of the phonograph in analyzing complex sounds, the writer says: "Hermann has obtained the curves corresponding to the tones of the vowels and has shown that vowels are true musical tones, each having its own pitch, and not, as Helmholtz supposes, the pitch of a harmonic tone corresponding to the shape of the oral cavity."

Now it is true that the vowels are true musical tones, but it is not true that each has its own pitch. The vowel sounds are a phenomenon, not of pitch, but of quality or *timbre*. All the vowels can easily be made successively without at all altering the pitch of the voice. Pitch is made in the larynx; the *timbre* is made in the mouth cavity. The one depends on the *number*, the other on the *form* of the waves. Doubtless the phonograph will prove a very useful instrument in analyzing vowel sounds; doubtless the investigations of Hermann and others mentioned are important; doubtless Helmholtz's theory will be corrected and improved, but that the vowel sounds are a phenomenon of *timbre* and not of pitch is too plain to be doubted. The writer has not fully understood or else not clearly stated either Helmholtz's theory or the bearing on it of these recent investigations.

JOSEPH LE CONTE.

UNIVERSITY OF CALIFORNIA.

[It would add much to the interest and value of this journal, and thus contribute to the advancement of science, if we should all follow the recommendations made by Professor Le Conte in his opening paragraph. J. McK. C.]

SCIENTIFIC LITERATURE.

Analytical Chemistry. By M. MENSCHUTKIN; translated by JAMES LOCKE. Macmillan & Co. Pp. 512. \$4.00 net.

Among the numberless text-books on analytical chemistry, the well-known work of Menschutkin appears to occupy an unique position in this respect, that the author emphasizes the didactic rather than the practical value of this branch of chemistry. Skill and accuracy in Qualitative and Quantitative Analysis have such a distinct commercial value that we cannot properly find fault with the share of attention they receive in the chemical curriculum of most institutions; the supply of competent analysts and essayers cannot be too great. But, in this age of specialization, it is allowable to ask whether the elementary education of the scientific investigator ought to be identical with that of the analyst.

Largely through the influence of one great writer, analysis has been 'codified,' and 'Fresenius' has become for the chemical student what 'Blackstone' is to the beginner in law. The ease with which we can acquire the principles and methods of analysis, by the careful study and practice of such a code, is wonderful; but we do not, in the meantime, advance appreciably beyond that point, in *chemical knowledge*, where the Elementary Inorganic Chemistry had left us. Menschutkin's book is intended, according to its Introduction, for students who propose advancing into Organic, Physical and Theoretical Chemistry, and he strives to cultivate the same habits of thought, in their study of Qualitative Analysis, as will be essential in the advanced branches.

This is an admirable standpoint, and one which should ensure the book a reading from all earnest students.

Unfortunately, there are a number of defects that impair its usefulness as a textbook. In the effort to enhance its didactic value by adhering to the inductive method, systematic treatment has been neglected. Descriptions of apparatus, operations and manipulations are introduced in such sequence as may afford the student progressive practice, indeed, but in no strictly logical order. As there is a very scanty index, it is impossible to refer to particular operations, for instance, without reading the book through. Unnecessary verbiage, frequent repetitions of facts already stated, facts connected very remotely with the subject in hand, tend to break the continuity and unnecessarily to increase the bulk of the volume.

Several times the wrong equations are given intentionally, 'because the right ones would be too complicated.' This seems to be rather unscientific treatment.

As for the actual subject-matter, both the special reaction and the systematic methods of Qualitative Analysis appear to be admirably chosen. Is it not time, however, that schemes for complete analysis should consider the possible presence of elements so frequently met with in natural and artificial products as are titanium, lithium, uranium and tungsten? It is also peculiar that, while the rarer elements are dismissed in the Qualitative Analysis, with a few paragraphs describing their most characteristic special reactions, these same paragraphs contain detailed instructions for their purification and quantitative determination!

The quantitative analysis of the common elements is treated in the last two hundred pages in an admirable manner, the separations especially receiving adequate consideration. But it seems queer to read of certain methods as recently discovered,

which have been in use ten or fifteen years; while the author appears to be quite unfamiliar, for instance, with the Gooch Crucible, whose use has removed so many obstacles from the analyst's path.

The translation is not done very skillfully—it is unidiomatic, and in many passages two or three readings are required before the author's sense can be accurately ascertained.

MORRIS LOEB.

UNIVERSITY OF THE CITY OF NEW YORK.

A Treatise on Civil Engineering. By W. M. PATTON. New York, John Wiley & Sons. 1895. Octavo, pp. xviii, 1654. Price, \$7.50.

Fifty years ago it was easy to compress the science and art of civil engineering into a single volume; to-day it is an impossibility. Civil, as distinguished from military, engineering is scarcely a century old, but its growth has been so vigorous, and the branches of its activity are so numerous, that the term is becoming somewhat vague. Telford's definition—the art that utilizes the materials and forces of nature for the benefit of man—was a good one in 1818, but it now can only be applied to the whole field of construction which is now subdivided into civil, mechanical, mining and electrical engineering.

The best definition that can now be given is perhaps the following: Civil engineering is the science and art of economic construction undertaken for the purpose of facilitating the transportation of men and matter. It thus embraces roads, railroads and canals, upon which men and freight are transported, together with river and harbor improvements; irrigation, water and sewerage systems for the transportation of water and sewage; and all the necessary foundations, bridges and structures for these objects. It includes all the surveys, estimates and mechanical principles required to build and maintain such construction in the most

economic manner consistent with the proper degree of security. The wonderful progress of the nineteenth century has, however, caused civil engineering to become divided in practice into special departments like railroad engineering, bridge engineering, irrigation engineering and sanitary engineering.

Mr. Patton's treatise, when tested by the above definition, is found to be defective; at the same time it is better and more comprehensive than would be expected when the vast range of the subject is considered. It includes fifty-nine chapters, together with an appendix of 125 pages. Many chapters contain information that can be found in no other single volume, clearly presented, well illustrated, and often set forth with the weight of authority that can attach only to the writings of an engineer who has long been in responsible charge of important construction work. Other chapters are compiled from standard treatises on special subjects, or from periodical literature. Throughout care and thoroughness are apparent, and a volume has been produced which is likely to be of much value to the younger members of the engineering profession.

Strictly speaking, the book is not a treatise, but its character is cyclopædic. A treatise is a classified and logical presentation in which causes precede their effects. Above all works on civil engineering, Rankine's manual stands highest as a treatise, for its theory is set forth in most logical relation to practice. Rankine's theory, though often difficult for students, is his own, and carefully coördinated on a uniform plan. Mr. Patton's method is one more suitable for a cyclopædia than a treatise, as his theoretic discussions have been largely adopted from other authors and have little coördination. For instance, the theory of earth pressure is taken from one author, the theory of trusses from another, and the theory of elas-

tic arches from a third. This has not been done without due credit, but in a treatise all these should have been worked out on a uniform basis and with systematic classification. Some investigations are also left more or less incomplete, with references to books where thorough discussions may be found. Such methods detract from the logical completeness that a true treatise should possess.

In one respect Mr. Patton has improved on the method of Rankine. Numerical examples are given illustrating the application of the theory. This is absolutely necessary for students and for most engineers, as algebra is always hazy, and mechanical principles are rarely well understood until they are applied to concrete problems. These examples are well selected to illustrate engineering practice, and they are usually worked out in a complete manner.

The most valuable and authoritative chapters are those relating to construction work, including earthwork, masonry, foundations, arches, dams, tunnels and river and harbor improvements. Numerous detailed descriptions of important works are presented to illustrate the best modern practice. The subject of the materials of engineering is set forth, not exhaustively, but clearly and well. As a cyclopædia of construction work the book may properly be called one of high rank.

The theory of bridges occupies much space, but it does not appear that the discussions contain any material improvements over the authorities whose methods have been mainly followed, unless it be in numerical illustrations. On hydraulic and sanitary engineering the book is weak. A few hydraulic formulas of value are given, but several long since discarded are also stated, and the elaborate determinations of hydraulic coefficients made in recent years are quite unnoticed. The separate system of sewerage is not mentioned, and little is

given relating to water works. These omissions show the defects of the author's system of classification, and demonstrate how impossible it is to write a satisfactory one-volume treatise on civil engineering at the present day. A comprehensive treatise, like the *Handbuch der Ingenieurwissenschaften*, must consist of many volumes and be the work of many men.

MANSFIELD MERRIMAN.

LEHIGH UNIVERSITY, July 29, 1895.

Electricity Up to Date for Light, Power and Traction. JOHN B. VERITY. London and New York, Frederick Warne & Co. 1894.

The preface of this book tells us that 15,000 copies have found their way into circulation. The title is a misnomer, unless the date is mentioned. In these days of active investigation and rapid application of discovered principles a book on electricity is out of date as it drops from the press. This statement is exemplified in this publication. The recent lucid investigations of Mr. R. E. Crompton on electric heating do not appear, and the surprising results of Mrs. Ayrton on the electric arc receive no mention. The various prime movers are mentioned, excepting the steam turbine, which, perhaps, is the most promising of all motors. The author ignores pretty generally what America is doing in the electric field, except in the case of Edison, to whom he gives credit for what was known before Edison was born—'the subdivision of the electric light.'

One of the first and certainly one of the simplest arc lamps, and the one most used, the Brush, receives no mention. There are several expressions which ought to be omitted from popular books, to prevent the spreading of erroneous ideas. Among these are 'Storage of Electricity,' used in this book as the head of a chapter; 'Electric Pressure,' for 'Difference of Potential.'

The confounding of these terms causes great confusion in the schools. We expect better things in a book which professes to be both scientific and popular. On page 184 is the statement that in a wire through which a current of electricity is passing 'the heat generated is proportional to the quantity of current used;' it would have been just as easy to have stated the exact law. The book is well printed and illustrated, but it is difficult to treat so large a subject in 200 pages with success. J. W. MOORE.

LAFAYETTE COLLEGE.

Neudrucke von Schriften und Karten über Meteorologie und Erdmagnetismus herausgegeben von Professor Dr. G. Hellmann, No. 4. E. HALLEY, W. WHISTON, J. C. WILCKE, A. VON HUMBOLDT, C. HANSTEEN. *Die ältesten Karten der Isogonen, Isoklinen, Isodynamen; 1701, 1721, 1768, 1804, 1825, 1826.* Berlin, A. Ascher & Co. 1895. Sieben Karten in Lichtdruck mit einer Einleitung. 26 pp., 4to.

The above forms No. 4 of the very interesting series of reprints in facsimile of epoch-making rare old books or charts in Meteorology and Terrestrial Magnetism edited by the well-known meteorologist and bibliographer, Professor Hellmann, of Berlin.

Like its predecessors,* the number before us commends itself by its keen, critical and thorough research, by its beautiful typographical execution and by the lowness of the price. Hardly one of the seven charts given could be obtained for the price (5 marks) asked for the whole. It is needless to remark that the editor of these successful reprints and his coöperators, the German Meteorological Society and its Berlin Branch, have thus merited the warmest

* No. 1. L. Reynman: *Wetterbüchlein. Von wahrer Erkenntniss des Wetters.* 1510.

No. 2. Blaise Pascal: *Récit de la Grande Expérience de l'Equilibre des Liqueurs.* Paris, 1648.

No. 3. Luke Howard: *On the modifications of clouds.* London, 1803.

praise. The pure geomagnetician will find additional satisfaction in the fact that Professor Hellmann appears to have abandoned his original intention of publishing the earliest meteorological and magnetic charts in one and the same volume. This differentiation of purely meteorological and magnetic matter cannot be too highly commended.

As announced in the title, the purpose of this number is to reproduce in facsimile the earliest geomagnetic charts. The amount of careful and painstaking research, as evinced by the many copious notes following the text, necessary for the completion of this task can only be thoroughly appreciated by those who have made similar attempts.

Plate I, gives Halley's famous lines of equal variation or magnetic declination for the epoch 1700.

Plate II, the earliest (1721) lines of equal magnetic inclination by W. Whiston for southern England and the Channel.

Plate III, the earliest *general* chart of the lines of equal inclination by J. C. Wilcke, published in 1768.

Plate IV, Humboldt's attempt at a representation of the distribution of the intensity of the earth's magnetism on both sides of the equator passing through Peru.

Plate V, the earliest delineation of the lines of equal magnetic force by Hansteen, published in 1825 and 1826.

A limited number of copies of the above can be obtained from the reviewer at the price named.

L. A. BAUER.

UNIVERSITY OF CHICAGO.

SCIENTIFIC JOURNALS.

THE PHYSICAL REVIEW, VOL. III., NO. 1,
JULY-AUGUST.

Thermal Conductivity of Copper. By R. W. QUICK, C. D. CHILD and B. S. LANPHEAR.

In a former paper (Phys. Rev., Vol. II., No. 6) the writers have given an account

of experiments made to determine the conductivity of copper at temperatures ranging from 70° to 170°. The present article is devoted to experiments upon the same copper bar at temperatures below 0°, the results being, so far as the writer is aware, the first that have been obtained for this range of temperatures. Several modifications in the method employed were made necessary by the new conditions. As a cooling bath, in which one end of the test bar was immersed, a mixture of solid CO₂ and ether was used. The temperature obtained by this means was about -70°. The formation of frost on the surface of the cold bar was a source of some annoyance, but was finally prevented by placing the bar in a large box filled with dry air. The temperature of the bar was measured, as in the previous experiments, by the resistance of a coil of fine copper wire, whose temperature coefficient was determined by reference to the melting points of ice and mercury.

The results show a variation in conductivity from 0.921 at -54° to 1.059 at 13°. It is to be observed that the increase of conductivity with rise of temperature corresponds with the behavior of the bar at high temperatures. The increase is, however, more rapid for temperatures below 0°. On the other hand, the average value of the conductivity for the range -54° to -13° is found to be slightly greater than the average value between 70° and 170°. Either, therefore, the results have been affected by some undiscovered source of error, or else the curve of conductivity must possess a maximum at some temperature between -14° and +70°. Determinations of conductivity for temperatures lying between this range are to be desired.

On Ternary Mixtures. I. By W. D. BANCROFT.

The attention which in recent years has been devoted to the subject of dissociation,

and to the development of the analogy between a dissolved substance and a gas, has heretofore prevented a systematic consideration of the more complex cases in which the solubility of one substance is influenced by the presence of a second. In the paper before us, which is the first of a series of articles on Ternary Mixtures, the experimental investigation of one of the simplest of such cases is begun: viz., the case of three liquids, two of which are non-miscible, while the third is miscible with each of the others in all proportions. Experiments were made with chloroform and water, and benzol and water, as non-miscible liquids, while ethylalcohol, methylalcohol and acetone were used as solvents. The quantity of solvent being kept constant, the amounts of the other two components necessary to produce saturation were determined. The results are found to be closely in agreement with the 'mass law': *i. e.*, if x and y denote the amounts of the non-miscible liquids the condition for saturation is $x^a y^\beta = C$ where a , β , and C are constants. When the curve showing the relation between x and y is plotted it is in general found, however, that a single curve is not sufficient to represent the experimental results. There appear to be two sets of conditions leading to equilibrium. A mixture of chloroform, water and alcohol may, for example, be saturated with respect to chloroform; in which case a precipitate of the latter liquid will be formed on the addition of *either* chloroform or water. A mixture of the same liquids may also be made which is saturated with respect to water. The proportions of water and chloroform are, of course, different in the two cases. The paper contains a discussion of several such cases, as well as numerous tables of experimental data.

On the Secular Motion of a Free Magnetic Needle. II. By L. A. BAUER.

The accumulation and discussion of the observational data used by Dr. Bauer have been described in the first half of this paper (*Phys. Rev.*, Vol. II., No. 6), and have already been noticed in SCIENCE. Practically all available sources of such data have been thoroughly searched, and the results collected constitute in themselves a valuable contribution to the literature of geomagnetism. By a combination and comparison of these data the author derives in the present paper certain important general laws regarding secular magnetic changes, which can perhaps best be stated in the language of the paper:

1. "In consequence of the secular variation of geomagnetism, the north end of a freely suspended magnetic needle, viewed from the center of suspension of the needle, moves on the whole earth in the direction of the hands of a watch."
2. "The secular variation curves appear to develop themselves more and more as we go around the earth eastwardly; or, in other words, the secular wave appears to travel in the main, roughly speaking, westward."
3. "The north end of a free magnetic needle, viewed from the center of suspension of the needle, moves clockwise in making an instantaneous easterly circuit of the earth along a parallel of latitude."
4. "The secular variation and the prevailing distribution of geomagnetism appear to be closely related."

Plates showing secular curves at different stations, as well as 'instantaneous curves' for several latitudes, accompany the paper. The author promises a mathematical discussion of the subject in the near future. Apart from the interest and value of the results obtained by Dr. Bauer, the directness and thoroughly scientific character of the work done form a pleasant contrast to the speculative and superficial methods by which the complex problem of geomagnetism are so often attacked.

A Galvanometer for Photographing Alternating Current Curves. By H. J. HOTCHKISS and F. E. MILLIS.

For the investigation of many important

alternating current problems the determination of the wave form by the ordinary method of instantaneous contacts is subject to many disadvantages. This method gives at most only a mean wave curve, corresponding to *steady* conditions. Some continuously recording instrument has long been needed, especially in the case of problems dealing with sudden changes in the conditions. But although numerous forms of apparatus have been suggested and tried, none of the methods proposed appears to be entirely satisfactory. The apparatus described in this article was constructed by Messrs. Hotchkiss and Millis for use in the study of sudden changes in an alternating current; such, for example, as the change brought about by a sudden change in load of a synchronous motor. The apparatus consists essentially of a very light needle, which is merely a mirror mounted on a piece of soft iron, suspended in a rather strong magnetic field. Surrounding the needle is a coil which carries the alternating current to be studied, the axis of the coil being perpendicular to the lines of force of the field. The needle is held in its zero position partly by the magnetic effect, and partly by the torsion of the short fiber, the latter being attached both above and below the needle. Being deflected by the action of the current it indicates current strength by its deflection, and constitutes a true galvanometer. A photographic registering device enables a continuous record of the variable current to be obtained.

The essential requirement for accuracy in such an instrument, viz., a short period of vibration, seems to have been filled. The frequency in the case of the five needles used varied from 2850 to 3950 complete vibrations per second. Curves taken from various types of alternating generation are shown, in which no trace of the natural vibration of the needle can be seen. Several 'make' and 'break' curves are shown also,

both for alternating and direct currents, which are of considerable interest.

The authors call attention to the fact that the apparatus can be used for other purposes besides the study of alternating currents. One interesting example of its application is a curve showing the temperature variation in the interior of a steam-engine cylinder during a single stroke, the temperature measurement depending on the change in the resistance of a fine iron wire.

Experiments with a New Polarizing Photo-Chronograph as Applied to the Measurement of the Velocity of Projectiles. By A. C. CREHORE and G. O. SQUIER.

To avoid the errors due to inertia, which are present in all ordinary types of chronograph, the present form of instrument is made to depend upon the rotation of the plane of polarization by a current. In the path of a beam of light, which is converged upon a moving photographic plate by a lens, are placed crossed nicols, and between them a tube filled with carbon bisulphide. If current flows in a coil surrounding this tube, light is restored, while if the current is broken, the light reaching the plate is *immediately* suppressed. The apparatus is especially suited to the measurement of small time intervals. In addition to a description of the instrument, the article contains an account of experiments made with it to determine the velocity of projectiles.

Experimental Demonstration of a Law of Fluid Pressure. W. J. HUMPHREY.

A description of a simple apparatus for showing that the pressure of a fluid is the same in all directions.

Books Reviewed.—Hertz. *Die Principien der Mechanik.* S. P. Thompson. *Elementary Lessons in Electricity and Magnetism.* Yeo. *Steam and the Marine Steam Engine.*

THE AMERICAN GEOLOGIST, AUGUST.

Joseph Granville Norwood, M. D., LL. D. By G. C. BROADHEAD.

Dr. Norwood's geological work was done between the years 1845 and 1855. He was associated with Dr. D. D. Owen in the Geological Survey of Wisconsin, Iowa and Minnesota, and was later State Geologist of Illinois. From 1860 to the time of his death (May 6, 1895) Dr. Norwood held a professorship in the University of Missouri, but on account of ill health his active work with that institution ceased in 1880. The paper is accompanied by a portrait and a list of publications.

The Keweenaw According to the Wisconsin Geologists. By N. H. WINCHELL.

This is the sixth in a series of papers entitled 'Crucial Points in the Geology of the Lake Superior Region.' With the conclusions of the Wisconsin Geological Survey concerning the Laurentian and Huronian the author does not essentially disagree, but he criticises the conclusions regarding the Keweenaw and the Upper Cambrian sandstones. It is stated that the Keweenaw was introduced by a period of subsidence and the deposition of conglomerates and sandstones, and that the great igneous activity of this age was later than these basal clastic rocks; the opposite view was held by the Wisconsin geologists. The author also brings forward evidence to show that there was not necessarily a long erosion interval (and a consequent unconformity) between the Keweenaw and the Upper Cambrian sandstones, as was held by the Wisconsin Geological Survey.

Superior Mississippian in Western Missouri and Arkansas. By CHARLES ROLLIN KEYES.

Recent work has shown that the upper Mississippian rocks in western Missouri, which have been regarded as not presenting a series easily parallelized with the typical rocks of this age in the Mississippi valley, are present in both their superior and inferior portions. The Burlington limestone is practically the same as at the typical

locality, and a typical Kaskaskia fauna is present in the uppermost member of the Mississippian.

Glacial Notes From the Planet Mars. By E. W. CLAYPOLE.

A summary of knowledge concerning the polar caps of Mars, which are believed to be composed of snow and ice, is presented. It is shown that Mars affords no evidence in support of the eccentricity theory of glacial cold, though his conditions are at present such as to favor a state of intense glaciation in his southern hemisphere.

Correlations of Stages of the Ice Age in North America and Europe. By WARREN UPHAM.

The series of stages of fluctuating growth and decline of the ice sheets on both sides of the North Atlantic are shown to be nearly alike and probably contemporaneous, so that the names proposed by Chamberlin for the principal American stages are applied also to the European, these names being here given on maps of the glacial drift of each continent. The marginal moraines of each are referred to the Champlain epoch, which was the short closing part of the Glacial period.

Besides the foregoing articles, this number contains departments of editorial comment, reviews of recent geological literature, lists of recent publications in geology, and personal and scientific news.

NEW BOOKS.

The Principles of Physics. ALFRED P. GAGE. Boston and London, Ginn & Co. 1895. Pp. ix + 634.

An Introduction to Chemical Crystallography. ANDREAS FOCK. Translated and edited by WILLIAM J. POPE. Oxford, The Clarendon Press. 1895.

Petrology for Students. ALFRED HARKER. Cambridge, University Press. 1895. Pp. viii + 306. \$2.00.

SCIENCE

NEW SERIES.
VOL. II. No. 34.

FRIDAY, AUGUST 23, 1895.

SINGLE COPIES, 15 CTS.
ANNUAL SUBSCRIPTION, \$5.00.

GUSTAV E. STECHERT'S Recent Importation of Scientific Books.

BECKERT, TH. und DR. ALBANO BRAND. Hüttenkunde. Mit 235 in den Text gedruckten Figuren. 765 Seiten. gr. 8^o. Mk. 20.

BEHRENS, H. Anleitung zur mikrochemischen Analyse. Mit einem Vorwort von Prof. S. Hoogerwerf in Delft. 224 Seiten mit 92 Figuren in Text. 8^o. Mk. 6.

BIEDERMANN, W. Elektrophysiologie. 1^{te} Abtheilung. Mit 136 Abbildungen. 440 Seiten. 8^o. Mk. 9.

BORCHERS, DR. W. Elektro-Metallurgie. Die Gewinnung der Metalle unter Vermittlung des elektrischen Stromes. 2^{te} verm. v. völlig umgearb. Auflage. 1^{te} Abtheilung, mit 87 Abbildungen. 160 Seiten. gr. 8^o. Mk. 6⁰⁰.

BUSCHAN, GEORG. Vorgeschichtliche Botanik der Cultur-u. Nutzpflanzen der alten Welt auf Grund prähistorischer Funde. 268 Seiten. 8^o. Mk. 7⁰⁰.

DAMMER, DR. O. Handbuch der chemischen Technologie. Unter Mitwirkung von Direktor Th. Beckert, Dr. Bender, Dr. Benedikt, Dr. Börnstein u. A. herausgegeben. 2^{tes} Band. Mit 235 in den Text gedruckten Figuren. gr. 8^o. Mk. 20.

DELAGE, YVES. La structure du protoplasma et les théories sur l'hérédité et les grands problèmes de la biologie générale. 878 pages. gr. 8^o cloth. frs 24⁰⁰.

DETMER, DR. W. Das pflanzenphysiologische Praktikum. Anleitung zu pflanzenphysiolog. Untersuchungen für Studierende u. Lehrer der Naturwissenschaften, sowie der Medicin, etc. 2^{te} völlig neubearbeitete Aufl. Mit 184 Abbildungen. 456 Seiten. 8^o. Mk. 9.

FOREL, DR. AUGUST. Der Hypnotismus, seine psycho-physiologische medicinische, strafrechtliche Bedeutung und seine Handhabung. 3^{te} verb. Aufl. mit Adnotationen von Dr. O. Vogt. 223 Seiten. gr. 8^o. Mk. 5.

FRANK, DR. A. B. Die Krankheiten der Pflanzen. Ein Handbuch für Land u. Forstwirte, Botaniker, etc. Erster Band, Die durch anorgan. Einflüsse hervorgerufenen Krankheiten. Mit 34 Holzschnitten. 2^{te} Aufl. 344 Seiten. 8^o. Mk. 6⁰⁰.

HIS, WILH. Die anatomische Nomenclatur. Nomina anatomica, Verzeichniss der von der anatomischen Gesellschaft auf ihrer 9. Versammlung in Basel angenommenen Namen. Mit 30 Abbildgn. im Text und 2 Tafeln. 180 Seiten. Mk. 7⁰⁰.

HOUDAILLE, F. Météorologie agricole. 204 pages cloth. fr. 3.

JAHRBUCH DER ELEKTROCHEMIE. Berichte über die Fortschritte des Jahres 1894. Im wissenschaftlichen Theile bearbeitet von Dr. W. Nernst. Im technischen Theile bearbeitet von Dr. W. Borchers. I^{er} Jahrgang. 274 Seiten. gr. 8^o. Mk. 10.

JERUSALEM, WILH. Die Utheilsfunction. Eine psychologische und erkenntnistheoretische Untersuchung. 269 Seiten. Mk. 6⁰⁰.

LOEUVY, DR. A. Untersuchungen über die Respiration and Circulation bei Aenderung des Druckes und des Sauerstoffgehaltes der Luft. Mit 5 Curventafeln im Text. 155 Seiten. gr. 8^o. Mk. 4.

MEYER, DR. ARTH. Untersuchungen über die Stärkekörner der höheren Pflanzen. Mit 9 Tafeln u. 99 Text-Abbildgn. 318 Seiten. gr. 8^o. Mk. 20⁰⁰.

NIEDENZU, DR. FRANZ. Handbuch für botanische Bestimmungsübungen. Mit 15 Figuren im Text. 351 Seiten. 8^o. Mk. 4.

SCHAFFER, DR. KARL. Suggestion und Reflex. Eine Kritisch-experimentelle Studie über die Reflexphänomene des Hypnotismus. Mit 6 Tafeln in Lichtdruck und 11 Abbildungen im Text. 113 Seiten. gr. 8^o. Mk. 6⁵⁰.

SCHMIDT, DR. ALEX. Weitere Beiträge zur Blutlehre. Nach des Verfassers Tode herausgegeben. 247 Seiten. 8^o. Mk. 7.

SCHWARTZE, TH. Die Lehre von der Electricität und deren praktische Verwendung. Mit 153 in den Text gedruckten Abbildungen. 543 Seiten. 8^o. Mk. 10⁰⁰.

STEINHARDT, DR. EUGEN. Kurzes Lehrbuch der Chemie zum Gebrauch an Schulen und zur Selbstbelehrung. Zwei Theile. Erst. Teil; Anorganische Chemie. 418 Seiten. 8^o. Mk. 6⁰⁰.

VAN BIERVLIET, J. J. Elements de psychologie humaine. Cours professé a l'université de Gand. Avec 34 figures dans le Text. 317 pages. frs. 8.

ZEITSCHRIFT FÜR ANGEWANDTE MIKROSKOPIE herausgegeben von G. Marquand. Monthly. I^{er} Band 1^{tes} Heft. Per year, \$2.75.

ZEITSCHRIFT, Geographische, Herausgegeben von Dr. Alfred Hettner. I^{er} Jahrg. 1^{tes} Heft. Per year (12 N^{os}) \$4⁰⁰.

ZIMMERMANN, DR. A. Das Mikroskop. Ein Leitfaden der wissenschaftlichen Mikroskopie. Mit 231 Figuren im Text. 334 Seiten. gr. 8^o. Mk. 9.

ZITTEL, KARL A. VON. Grundzüge der Paläontologie (Paläozoologie). Mit 2048 in den Text gedruckten Abbildungen. 971 Seiten. gr. 8^o. $\frac{1}{2}$ mor. Mk. 25⁰⁰.

GUSTAV E. STECHERT,

810 Broadway, New York.

Macmillan & Co.'s New Publications.

The Cell: Outlines of General Anatomy and Physiology.

By DR. OSCAR HERTWIG, Professor Extraordinarius of Anatomy and Comparative Anatomy, Director of the II. Anatomical Institute of the University of Berlin. Translated by M. CAMPBELL and Edited by HENRY JOHNSTONE CAMPBELL, M. D., Assistant Physician to the City of London Hospital for the Diseases of the Chest, etc. With 168 Illustrations. 8vo, cloth, pp., \$3.00, *net*.

The American Commercial Policy.

Three Historical Essays. By UGO RABBENO, Professor of Political Economy in the University of Modena. Second Edition. Partly rewritten and entirely revised by the author. Translated at the Translations Bureau, London, W. C. 8vo, cloth, pp. 414, \$3.25, *net*.

Analytical Chemistry.

By N. MENSCHUTKIN, Professor in the University of St. Petersburg. Translated from the third German edition under the supervision of the Author. By JAMES LOCKE. 8vo, cloth, pp. xii+512, \$4.00, *net*.

The Great Frozen Land. Narrative of a Winter Journey Across the Tundras and a Sojourn Among the Samoyads.

By GEORGE F. JACKSON, Fellow of the Royal Geographical Society and Leader of the Jackson-Harmsworth Polar Expedition. With Illustrations and Maps. Edited from his Journals by ARTHUR MONTEFIORE. 8vo, cloth, pp. xviii+297, \$4.50.

Cambridge Natural Science Manuals.

A Text-Book of Zoögeography. By FRANK E. BEDDARD, M. A. (Oxon), F. R. S., Professor of the Zoölogical Society of London, and Lecturer on Biology at Guy's Hospital. 12mo, cloth, \$1.60, *net*. (*Biological Series*.)

Second Volume of the Century Science Series.

Edited by SIR HENRY E. ROSCOE, D. C. L., etc. (*Biographies of Eminent Men of Science*.)

Major Rennell, F. R. S., and the Rise of English Geography.

By CLEMENTS R. MARKHAM, C. B., F. R. S., President of the Royal Geographical Society. 12mo, cloth, \$1.25.

First Volume: John Dalton and the Rise of Modern Chemistry.

By SIR HENRY E. ROSCOE, F. R. S., etc. 16mo, cloth, \$1.25. Other volumes of this series in preparation.

The Horticulturist's Rule-Book.

A Compendium of Useful Information for Fruit-growers, Truck-gardeners, Florists and others. By L. H. BAILEY, Professor of Horticulture in Cornell University. Third Edition, thoroughly Revised and Recast, with many Additions. 12mo, limp cloth, 75 cents.

Short Studies in Nature Knowledge. An Introduction to the Science of Physiography.

By WILLIAM GEE, Certified Teacher of the Education Department and of the Science and Art Departments. Illustrated with 117 engravings, comprising portraits, views, etc. 12mo, cloth, \$1.10, *net*.

MACMILLAN & CO., 66 Fifth Avenue, New York.

SCIENCE

EDITORIAL COMMITTEE: S. NEWCOMB, Mathematics; R. S. WOODWARD, Mechanics; E. C. PICKERING, Astronomy; T. C. MENDENHALL, Physics; R. H. THURSTON, Engineering; IRA REMSEN, Chemistry; J. LE CONTE, Geology; W. M. DAVIS, Physiography; O. C. MARSH, Paleontology; W. K. BROOKS, Invertebrate Zoology; C. HART MERRIAM, Vertebrate Zoology; S. H. SCUDDER, Entomology; N. L. BRITTON, Botany; HENRY F. OSBORN, General Biology; H. P. BOWDITCH, Physiology; J. S. BILLINGS, Hygiene; J. MCKEEN CATTELL, Psychology; DANIEL G. BRINTON, J. W. POWELL, Anthropology.

FRIDAY, AUGUST 23, 1895.

CONTENTS:

| | |
|--|-----|
| <i>The Relationships and Responsibilities of Museums:</i> | |
| G. BROWN GOODE | 197 |
| <i>The Processes of Life Revealed by the Microscope:</i> | |
| SIMON HENRY GAGE..... | 209 |
| <i>Consciousness and Evolution:</i> J. MARK BALDWIN..... | 219 |
| <i>The Science of Examining:</i> PETER T. AUSTEN..... | 223 |
| <i>The 'New Race' in Egyptian History:</i> D. G. BRINTON..... | 227 |
| <i>Current Notes on Physiography (XIV.):—</i> | 228 |
| <i>Foreau's Expedition into the Sahara; Laccolitic Mountain Groups; The Run-off of Rivers:</i> W. M. DAVIS..... | 229 |
| <i>Scientific Notes and News:—</i> | 229 |
| <i>The British Medical Association; Section C, Chemistry, of the A. A. A. S.; The Botanical Society of America; Vital Statistics of New England; General.</i> | |
| <i>University and Educational News.</i> | 233 |
| <i>Correspondence:—</i> | 234 |
| <i>A New Bibliographical Bureau for Zoology:</i> HERBERT HAVILAND FIELD..... | 237 |
| <i>Scientific Literature:—</i> | 237 |
| <i>Jaccard's Le pétrole, Vashalle et le bitume:</i> S. F. PECKHAM; <i>Honarth's Glacial Nightmare and the Flood:</i> J. W. SPENCER; <i>Talbot's Etiology of Osseous Deformities:</i> CHARLES L. DANA; <i>Double Refraction in Wood:</i> WILLIAM HALLOCK; <i>Magnetic Declination in Alaska:</i> L. A. BAUER. | |

MSS. intended for publication and books, etc., intended for review should be sent to the responsible editor, Prof. J. McKeen Cattell, Garrison on Hudson, N. Y.
Subscriptions and advertisements should be sent to SCIENCE, 41 N. Queen St., Lancaster, Pa., or 41 East 49th St., New York.

THE RELATIONSHIPS AND RESPONSIBILITIES OF MUSEUMS.*

In an article on 'The use and abuse of Museums,' written nearly fifteen years ago

* Part of a paper on 'The Principles of Museum Administration,' read before the *Museums Association*, at Newcastle-on-Tyne, July 23, 1895.

by Professor William Stanley Jevons, attention was directed to the circumstance that there was not, at that time, in the English language a treatise analyzing the purposes and kinds of museums, and discussing the general principles of their management and economy. It is somewhat surprising that the need then made so evident had not since been supplied and that there is not at the present day such a treatise in the English or any other language. Many important papers have in the interval been printed in regard to particular classes of museums and special branches of museum work. Notable among these have been those written by Sir William H. Flower, Professor W. A. Herdman, Dr. J. S. Billings, Dr. H. H. Higgins, Dr. Albert Günther and General Pitt Rivers, and there had previously been printed the well known essay of Dr. J. E. Gray, Edward Forbes' suggestive paper on 'Educational Uses of Museums,' in 1853, and the still earlier one by Edward Edwards on 'The Maintenance and Management of Public Galleries and Museums,' printed in 1840.

No one has as yet attempted, however, even in a preliminary way, to formulate a general theory of administration applicable to museum work in all its branches, except Professor Jevons, who, in the paper already referred to, presented in an exceedingly impressive manner certain ideas which should underlie such a theory.

It is still true, as it was when Professor Jevons wrote, in 1881, that there is not in existence 'a treatise analyzing the purposes and kinds of museums and discussing the general principles of their management and economy.' With this fact in mind I have ventured to begin the preparation of such a treatise and to attempt to bring together in one systematic sequence the principles which I believe to underlie the practice of the wisest and most experienced of modern museum administrators.

My ideas are presented, it may be, in a somewhat dogmatic manner, often in the form of aphorisms, and to the experienced museum worker many of them will, perhaps, sound like truisms.

I have had two objects in view:

It has been my desire, in the first place, to begin the codification of the accepted principles of museum administration, hoping that the outline which is here presented may serve as the foundation for a complete statement of those principles, such as can only be prepared through the coöperation of many minds. With this in view, it is hoped that the paper may be the cause of much critical discussion.

My other purpose has been to set forth the aims and ambitions of modern museum practice, in such a manner that they shall be intelligible to the persons who are responsible for the establishment of museums and also to the directors of other public institutions founded for similar purposes, in order to evoke more fully their sympathy and coöperation.

Museums of art and history, as well as those of science, are discussed in this paper, since the same general principles appear to be applicable to all.

The theses proposed are two hundred and fifteen in number and are arranged under the following heads or chapters:

- I. The Museum and its Relationship;
- II. The Responsibilities and Requirements

- of Museums; III. The Five Cardinal Necessities in Museum Administration; IV. The Classification of Museums; V. The Uses of Specimens and Collections; VI. The Preservation and Preparation of Museum Materials; VII. The Art of Installation; VIII. Records, Catalogues and Specimen Labels; IX. Exhibition Labels and Their Function; X. Guides and Lecturers; Hand Books and Reference-books; XI. The Future of Museum Work.

[The introductory portion, consisting of the first three chapters, and the last chapter are here printed. The remainder of the paper is more technical and is intended especially for the consideration of persons engaged directly in museum work.]

THE MUSEUM AND ITS RELATIONSHIPS.

A. *The Museum Defined.*

1. A museum is an institution for the preservation of those objects which best illustrate the phenomena of nature and the works of man, and the utilization of these for the increase of knowledge and for the culture and enlightenment of the people.

B. *The Relation of the Museum to other Institutions of Learning.*

1. The Museum in its effort for the increase and diffusion of knowledge aids and is aided by (a) the university and college, (b) the learned society and (c) the public library.

2. The special function of the museum is to preserve and utilize objects of nature and works of art and industry; that of the library to guard the written records of human thought and activity; that of the learned society to discuss facts and theories; that of the school to educate the individual, while all meet together on common ground in the custodianship of learning and in extending the boundaries of existing knowledge.

3. The care and utilization of material objects being the peculiar duty of the mu-

seum, it should not enter the field of other institutions of learning, except to such a degree as may be found absolutely necessary in connection with its own work.

[For example, its library should contain only such books as are necessary for use within its own walls. Its publications should be solely those which are (directly or indirectly) the outgrowth of its own activities. Its teaching work should be such as cannot be performed by other institutions.

On the other hand, schools may advantageously limit their cabinets with reference to the needs of their lecture rooms and laboratories. The library and the learned society should not enter the field of the museum, except in localities where museum agencies are not provided.]

C. *The Relation of the Museum to the Exposition.*

1. The Museum differs from the Exposition both in its aims and in the method of its activity.

2. The Exposition, or Exhibition, and the Fair are primarily for the promotion of industry and commerce; the Museum for the advancement of learning.

3. The principal object of the former is to make known the names of the exhibitors for their own professional or financial advantage; in the latter the name of the exhibitor is incidental, the thing chiefly in mind being the lesson taught by the exhibit.

4. Into the work of the former enters the element of competition, coupled with a system of awards by diplomas or medals; in that of the latter the element of competition does not appear.

5. The educational results of expositions, though undeniably important, are chiefly incidental, and not at all proportionate to the prodigal expenditure of energy and money which are inseparable from any great exposition.

D. *Museum Features Adopted in Expositions.*

1. Museum methods have been in part adopted by many expositions, in some instances to attract visitors, in others because it has been desired to utilize the occasion to give museum lessons to multitudes to whom museums are not accessible.

2. Those expositions which have been most successful from an educational standpoint have been the ones which have most fully availed themselves of museum methods, notably the London Exhibition of 1851 and the Paris Exposition of 1889.

3. Special or limited exhibitions have a relatively greater educational value, owing to the fact that it is possible in these to apply more fully the methods of the museum. Examples of this principle were afforded by the four expositions held in London from 1883 to 1886—Fisheries, Health, Inventions and Colonial.

4. The annual exhibitions of the academies of art are allied to the exposition rather than to the museum.

5. Many so-called 'museums' are really 'permanent exhibitions,' and many a great collection of pictures can only be suitably described by the name 'picture gallery.'

E. *Temporary Museums.*

1. There are many exhibitions which are administered in accordance with museum principles and which are really temporary museums. To this class belong the best of the loan exhibitions, and also special exhibits made by public institutions, like the 'Luther Memorial Exhibition' of 1874, the material for which was derived chiefly from the Library of the British Museum, and similar exhibitions subsequently held under the same auspices.

F. *Museum Methods in other Institutions—'Museum Extension.'*

1. The zoölogical park, the botanical garden and the aquarium are essentially mu-

seums, and the principles of museum administration are entirely applicable to them.

2. An herbarium in its usual form corresponds to the study series in a museum, and is capable of expansion to the full scope of the general museum.

3. Certain churches and ecclesiastical edifices and classical antiquities in place, when they have been pronounced 'public monuments,' are subject to the principles of museum administration.

4. Many cities, like Rome, Naples, Milan and Florence, by reason of the number of buildings, architectural features, sculpture and other objects in the streets and squares, together with the historical houses duly labeled by tablets, have become practically great museums, and these various objects are administered much in the manner of museums. Indeed, the number of 'Public Monuments' in Italy is so great that the whole country may properly be described as a museum of art and history. A government commission for the preservation of the monuments of history and art regulates the contents of every church, monastery and public edifice, the architectural features of private buildings, and even private collections, to the extent of requiring that nothing shall be removed from the country without governmental sanction. Each Italian town is thus made a museum, and in Rome the site of the Forum and the adjacent ancient structures has been set aside as an outdoor museum under the name of the *Passeggiata Archeologica*.

Similar government control of public monuments and works of art exists in Greece and Egypt, and in a lesser degree in the Ottoman Empire, and for half a century there has been a Commission of Historic Monuments in France, which has not only succeeded in protecting the national antiquities, but has published an exceedingly important series of descriptive monographs concerning them.

THE RESPONSIBILITIES AND REQUIREMENTS OF MUSEUMS.

A. *The Relation of the Museum to the Community.*

1. The museum meets a need which is felt by every intelligent community and furnishes that which cannot be supplied by any other agency. The museum does not exist except among enlightened peoples, and attains its highest development only in great centres of civilization.

2. The museum is more closely in touch with the masses than the university and learned society, and quite as much so as the public library, while, even more than the last, it is a recent outgrowth of modern tendencies of thought. Therefore,

3. THE PUBLIC MUSEUM IS A NECESSITY IN EVERY HIGHLY CIVILIZED COMMUNITY.

B. *The Mutual Responsibilities of the Community and the Museum.*

1. The museums in the midst of a community perform certain functions which are essential to its welfare, and hence arise mutual responsibilities between the community and the museum administrator.

2. The museum administrator must conduct his work with the highest possible degree of efficiency, in order to retain the confidence of the community.

3. The community should provide adequate means for the support of the museum.

4. A failure on the part of the one must inevitably lead to a corresponding failure on the part of the other.

C. *The Specific Responsibilities of the Museum.*

1. The museum should be held responsible for special services, chiefly as follows:

a. *For the advancement of learning.*—To aid learned men in the work of extending the boundaries of knowledge, by affording them the use of material for investigation, laboratories and appliances.

To stimulate original research in connection with its own collections, and to promote the publication of the results.

b. *For record.*—To preserve for future comparative and critical study the material upon which past studies have been made, or which may serve to confirm, correct or modify the results of such studies. Such materials serve to perpetuate the names and identifications used by investigators in their publications and, thus authenticated, to serve as a basis for future investigation in connection with new material. Specimens which thus vouch for the work of investigators are called *Types*. Besides types museums retain for purposes of record many specimens which, though not having served for investigation, are landmarks for past stages in the history of man and nature.

c. *As an adjunct to the class room and the lecture room.*—To aid the teacher either of elementary, secondary, technological or higher knowledge in expounding to his pupils the principles of art, nature and history, and to be used by advanced or professional students in practical laboratory or studio work.

To furnish to the advanced or professional student materials and opportunity for laboratory or studio training.

d. *To impart special information.*—To aid the occasional inquirer, be he a laboring man, school boy, journalist, public speaker or savant, to obtain, without cost, exact information upon any subject related to the specialities of the institution; serving thus as a 'bureau of information.'

e. *For the culture of the public.* To serve the great general public, through the display of attractive exhibition series, well-planned, complete and thoroughly labeled; and thus to stimulate and broaden the minds of those who are not engaged in scholarly research, and draw them to the public library and the lecture room. In

this respect the effect of the museum is somewhat analogous to that of travel in distant lands.

2. A museum to be useful and reputable must be constantly engaged in aggressive work, either in education or investigation, or in both.

3. A museum which is not aggressive in policy and constantly improving cannot retain in its service a competent staff and will surely fall into a decay.

4. A FINISHED MUSEUM IS A DEAD MUSEUM, AND A DEAD MUSEUM IS A USELESS MUSEUM.

5. Many so-called 'museums' are little more than storehouses filled with the materials of which museums are made.

D. *The Responsibility of Museums to Each Other.*

1. There can be no occasion for envious rivalry between museums, even when they are in the same city. Every good museum strengthens its neighbors and the success of the one tends to the popularity and public support of the others.

2. A system of coöperation between museums, by means of which much duplication of work and much expenditure of work may be avoided, is seemingly possible.

3. The first and most important field for mutual understanding is in regard to specialization of plan. If museums in the same town, province or nation would divide the field of work so that each should be recognized as having the first rights in one or more specialities, rivalry would be converted into friendly association and the interests of science and education better served.

4. An important outcome of such a system of coöperation might be the transfer of entire groups of specimens from one museum to another. This would greatly facilitate the work of specialization referred to, and at the same time relieve each museum of the responsibility of maintaining collec-

tions which are not germane to its real purpose. Such transfers have occasionally been made in the past, and there are few museums which might not benefit individually, in a large degree, by a sweeping application of this principle. If its effect upon the effectiveness and interest of any local or national group of museums is taken into account, no one can doubt that the result would be exceedingly beneficial.

5. Another field for coöperation is in joint expenditure of effort and money upon labels and catalogues and in the economical purchase of and in supplies and material.

6. Still another would lie in the coöperative employment of expert curators and preparators, it being thus practicable to pay larger salaries and secure better men.

THE FIVE CARDINAL NECESSITIES IN MUSEUM ADMINISTRATION.

The Essentials of Success in Museum Work.

A museum cannot be established and creditably maintained without adequate provision in five directions:

1. A stable organization and adequate means of support.

2. A definite plan, wisely framed in accordance with the opportunities of the institution and the needs of the community for whose benefit it is to be maintained.

3. Material to work upon—good collections or facilities for creating them.

4. Men to do the work—a staff of competent curators.

5. Appliances to work with—a suitable building, with proper accessories, installation material, tools and mechanical assistants.

A. *Stability of Organization.*

1. The only absolute assurance of permanence for a museum lies either in governmental protection, in a connection with some endowed institution of learning, or in special organization with ample endowments.

2. The cabinets of unendowed societies, or those gathered and supported by the efforts of individuals, must in time inevitably be dispersed or destroyed.

B. *Definiteness of Plan.*

1. No two museums can be or ought to be exactly alike. Each should be devoted to one or more special subjects, and should select those subjects not only in reference to opportunity and the needs of the community, but also with regard to the specialties of other museums in the same region, with a view to coöperation.

2. It is the duty of every museum to be preëminent in at least one specialty, be this specialty never so limited.

3. The specialties or departments of any museum may be few or many, but it is important that its plan should be positively defined and limited, since lack of purpose in museum work leads in a most conspicuous way to waste of effort and to failure, partial or complete.

4. It will undoubtedly be found desirable for certain museums, founded for local uses, to specialize mainly in the direction of popular education. If these cannot also provide for a certain amount of scholarly endeavor in connection with their other activities, it is of the utmost importance that they should be associated (by a system of administrative coöperation) with some institution which is a centre of original work.

5. The general character of a museum should be clearly determined at its very inception. Specialization and division of labor are essential for institutions as well as for individuals. It is only a great national museum which can hope to include all departments and which can with safety encourage growth in every direction.

6. Small museums, it is needless to say, cannot attempt specialization in the same degree as large ones, but the principles just

enunciated should be constantly kept in view, even by the least of them.

C. Collections.

1. The sources of collections are the following: (a) By gift; (b) by purchase; (c) by exchange; (d) by collection and exploration; (e) by construction; (f) through deposit or temporary loan.

a. *By gift.*—Acquisition by gift is a most important source, but very uncertain. If a museum has a plan to which it intends to adhere, a large proportion of the gifts offered to it will be unavailable; while, on the other hand, only a small proportion of the desiderata will ever be thus obtained. A museum may properly, by the offer of a large and complete collection illustrating a subject outside of its plan, be induced to expand its scope. In the case of a large benefaction of this kind, necessitating extensive changes in installation, there must always be careful consideration of the result. It should be borne in mind, however, that the random, thoughtless acceptance of proffered gifts, which in the course of a few years produces results by no means insignificant in the consumption of space and money for their care, may modify the plan of a museum in a most radical manner. It requires quite as much judgment and mental effort on the part of a museum officer to keep out unsuitable objects as to bring in those which are desirable.

b. *By purchase.*—Acquisition by purchase is often the only means of obtaining desirable objects, particularly so in the case of art museums, least so in natural history museums. Money is especially necessary for the filling of gaps in series obtained by gift or otherwise.

c. *By exchange.*—Acquisition by exchange is especially advantageous, since it enables a museum to dispose of unavailable duplicate material. When exchanges are made with well-conducted museums there is the

additional advantage that the materials thus obtained have been studied and identified by expert authorities. Little is gained by conducting exchanges in a commercial spirit and in insisting on too exact valuations and balancing of equivalents, especially when the parties to the exchange are public institutions. Large museums in dealing with small ones may often advantageously give largely and receive comparatively little in return, since they not only become disembroiled of useless duplicates not desired by institutions of equal rank, but are also building up sister institutions which may in time afford them much more substantial aid. Exchanges with private collectors may well be carried on in the same spirit, since the collector is thus encouraged to gather more material, in the midst of which unexpected treasures may come to light, and is also aided to build up a private collection which in time will probably fall into the hands of some public museum.

d. *By collecting and exploration.*—For all museums save those of art this is usually the most profitable and satisfactory, since by gathering fresh material in unexplored fields, new facts are discovered, science is enriched, and the reputation of the institution improved. Furthermore, material is obtained in such large quantities that there always remains much in the way of duplicate specimens valuable for exchange. A museum which carries its activities into unexplored fields secures for itself material which is unique and unobtainable by others, and thus makes itself a centre of interest for the entire world.

The smallest museum may enrich its collections by modest explorations under its own walls; it can do much by simply encouraging the people in the adjacent region to save what they accidentally encounter in the course of their daily pursuits. Explorations of this kind are preëminently the function of local and provincial museums.

e. *By construction.*—Any museum may do much to improve its exhibition series by the construction of models and the making of drawings and maps and by taking copies of important objects in its own collections, to secure material to be used in exchange. Even small museums may do this, for extensive workshops are not necessary and a specialist, himself devoid of mechanical skill, may accomplish marvelous things with the aid of a patient mechanic.

f. *Through deposit and temporary loan.*—Possessors of private collections will often lend them for purposes of exhibition or study, if assured that they will be properly cared for. Such loan collections often become permanent gifts. Single specimens, or small groups of objects, are still more frequently offered on deposit, and such deposits, when within the province of the museum, should be encouraged.

[In the United States National Museum small deposits are received for short periods, but large collections involving trouble and expense in installation, only with the understanding that they shall not be removed within a certain period—never less than two years.]

2. Collections which are encumbered by conditions as to manner of disposition and installation are usually sources of serious embarrassment. It is especially undesirable to accept either as a gift or as a loan any unimportant collection with the pledge that it shall be kept intact and installed as a unit. The acceptance of any collection, no matter how important, encumbered by conditions, is a serious matter, since no one can foresee how much these conditions may interfere with the future development of the museum.

3. Gifts, deposits and coöperation of all kinds may be greatly encouraged by liberal acknowledgment upon labels and in public reports. This is but simple justice to the generosity of the benefactor. It is also a

legitimate way to gratify a natural and and praiseworthy sentiment; for a collection to the accumulation of which a man has devoted a lifetime becomes so connected with his own personality that it is but natural that he should wish his name to be permanently associated with it. If acknowledgment of this kind is made upon the individual label of each specimen, this will usually fully satisfy the desire of the donor that the individuality of his gift should be preserved—an arrangement much more satisfactory than a plan requiring that the objects shall be kept together and treated as a unit of installation.

Gifts and deposits are also encouraged by the fact that the buildings are fire-proof, the cases so built as to afford perfect protection, and the scheme of installation dignified and attractive. Collections of great value may well be afforded accommodations of a specially sumptuous character and such protection, in the case of priceless objects, as is afforded by special electric attachments.

4. Since the plan and character of a museum is largely determined for all time by the nature of the collections which fall first into its possession, at the time of its organization, the authorities in charge of such an institution at the time of organization should be exceedingly careful in accepting materials which are to serve as a nucleus for its future growth.

[It is not unusual for boards of trustees, having erected a building, to proceed at once to partially fill it with showy material before the staff has been appointed or a plan considered. This can only be characterized as pernicious activity which is certain to result in more harm than good. A plan having been determined upon and a director selected, the collections may be developed with much less expenditure and with any degree of rapidity which may be desired.]

D. *Museum Officers.*

1. A museum without intelligent, progressive and well-trained curators is as ineffective as a school without teachers, a library without librarians, or a learned society without a working membership of learned men.

2. Museum administration has become one of the learned professions, and success in this field can only be attained as the result of years of study and experience in a well-organized museum. Intelligence, a liberal education, administrative ability, enthusiasm, and that special endowment which may be called 'the museum sense' are prerequisite qualifications.

Each member of the museum staff should become an authority in some special field of research, and should have time for investigation and opportunity to publish its results.

3. A museum which employs untrained curators must expect to pay the cost of their education in delays, experimental failures and waste of materials.

4. No investment is more profitable to a museum than that in its salary fund, for only when this is liberal may the services of a permanent staff of men of established reputation be secured.

Around the nucleus of such a staff will naturally grow up a corps of volunteer assistants, whose work properly assisted and directed will be of infinite value.

5. Collaborators, as well as curators, may be placed upon the staff of a large museum, the sole duty of the former being to carry on investigations, to publish, and, if need be, to lecture.

6. Volunteers may be advantageously employed either as curators and custodians, or collaborators. Such coöperation is especially desirable and practicable when a museum is situated in the same town with a college or university, or in a national capital where there are scientific bureaus

connected with the government. Professors in a university or scientific experts in the government service often find it a great benefit to have free access to the facilities afforded by a museum, and are usually able to render useful service in return. Younger men in the same establishments may be employed as volunteer aids, either in the museum or in the field.

7. No man is fitted to be a museum officer who is disposed to repel students or inquirers, or to place obstacles in the way of access to the material under his charge.

8. A museum officer or employee should, for obvious reasons, never be the possessor of a private collection.

9. The museum which carries on explorations in the field as a part of its regular work has great advantage over other institutions in holding men of ability upon its staff and in securing the most satisfactory results from their activities. No work is more exhaustive to body and mind than the care of collections, and nowhere are enthusiasm and abundant vitality more essential. Every museum must constantly obtain new material through exploration, and it is better that this exploration should be done by the men who are to study the collections and arrange them in the museum than that this work should be placed in the hands of others.

10. In a large museum staff it is almost essential that certain persons should give their attention chiefly to administrative and financial matters, thus leaving their associates free from occupation of this description. The business affairs of a museum cannot be conducted with too great promptness and precision. It is desirable, however, that the administrative officers of a museum should be men who comprehend the meaning of museum work and are in sympathy with its highest aims, and that its business affairs and scientific work should be controlled by the same executive head.

E. *Museum Buildings.*

1. The museum building should be absolutely fire-proof and substantially constructed; the architecture simple, dignified and appropriate—a structure worthy of the treasures to be placed within.

2. Above all things the interior should be well lighted and ventilated, dry and protected from dust. The halls should be well proportioned, the decoration simple and restful to the eye. No decorative features should be permitted which might draw attention from the collections or reduce the floor or wall space.

3. While the museum building should be planned with reference to the character of the collections it is to contain, the fact that unexpected development of rapid growth in some one direction may necessitate the rearrangement and reassignment of halls to different departments should always be kept in mind.

4. Since no two museums can be alike, there can be no general uniformity in their buildings. It is manifestly undesirable then that a board of trustees should erect a building for a museum before its character is decided upon or its staff appointed; or that the opinion of the architect of a museum building should be allowed to outweigh the judgment of the experts who are responsible for its utilization after completion. Museum architecture affords no exception to the principle that an edifice should be perfectly adapted to the purpose for which it is designed. No architectural effect which lessens the usefulness of the building can be pleasing to an intelligent public.

F. *Accessories to Museum Work.*

1. A well-equipped museum requires as accessories to its work:

a. A reference library for the use of staff, students and visitors.

b. Laboratories for the classification of

material, for the storage of the study-series, and for the use of students and investigators.

c. Workshops, for preparation, mounting and repair of specimens, and the making and adjustment of mounts and cases, and storage rooms for material not yet available. A printing press is a most essential feature.

d. An assembly hall, for public lectures, society meetings and special exhibitions.

e. A bulletin, or other official publication, to preserve the history of its activities, to maintain its standing among similar institutions, to serve as a means of communication with correspondents, and to exchange for specimens and books for the library.

2. In addition to local accessories, the opportunity for exploration and field work are equally essential, not only because of considerations connected with the efficiency of the staff, but for the general welfare of the institution. Other things being equal, exploration can be carried on more effectively by the museum than by any other institution of learning, and there is no other field of research which it can pursue to better advantage.

THE FUTURE OF MUSEUM WORK.

A. *The Growth of the Museum Idea.*

1. There can be no doubt that the importance of the museum as an agency for the increase and diffusion of knowledge will be recognized so long as interest in science and education continues to exist. The prediction of Professor Jevons in 1881, that the increase in the number of museums of some sort or other must be almost coextensive with the progress of real popular education, is already being realized. Numerous local museums have been organized within the past fifteen years in the midst of new communities. Special museums of new kinds are developing in the old centres, and every university, college and school is organizing

or extending its cabinet. The success of the Museums Association in Great Britain is another evidence of the growing popularity of the museum idea, and similar organizations must of necessity soon be formed in every civilized country.

2. With this increase of interest there has been a corresponding improvement in museum administration. More men of ability and originality are engaging in this work, and the results of this are manifest in all its branches.

The museum recluse, a type which had many representatives in past years, among them not a few eminent specialists, is becoming much less common, and this change is not to be regretted. The general use of specimens in class-room instruction and, still more, the general introduction of laboratory work in the higher institutions, has brought an army of teachers into direct relations with museum administration, and much support and improvement has resulted.

3. Museum administration has become a profession, and the feeling is growing more and more general that it is one in which talents of a high order can be utilized. It is essential to the future development of the museum that the best men should be secured for this kind of work, and to this end it is important that a lofty professional standard should be established.

B. *Public Appreciation of the Material Value of Collections.*

1. The museum of nature or art is one of the most valuable material possessions of a nation or a city. It is, as has well been said, 'the people's vested fund.' It brings not only world-wide reputation, but many visitors and consequent commercial advantage. What Alpine scenery is to Switzerland, museums are to many neighboring nations. Some one declares that the Venus of Melos has attracted more wealth to Paris than the Queen of Sheba brought to King

Solomon, and that but for the possession of their collections (which are intrinsically so much treasure) Rome and Florence would be impoverished towns.

This is thoroughly understood by the rulers of modern Italy. We are told that the first act of Garibaldi after he had entered Naples in 1860 was to proclaim the city of Pompeii the property of the nation, and to increase the appropriation for excavations so that these might be carried on with greater activity. He appreciated the fact that a nation which owns a gold mine ought to work it, and that Pompeii could be made for Naples and for Italy a source of wealth more productive than the gold mines of Sacramento. If capital is an accumulation of labor, as economists say, works of art which are the result of the highest type of labor must be capital of the most productive character. A country which has rich museums attracts to itself the money of travelers, even though it may have no other source of wealth. If, besides, the populace is made to understand the interest which is possessed by their treasures of art they are inspired with the desire to produce others of the same kind, and so, since labor increases capital, there is infinite possibility for the growth of national prosperity. It is evident then that too much money cannot be devoted to the formation of museums, to their maintenance, and to the education of the people by this means.

Suggestive in this same connection is this remark of Sir William Flower to the effect that the largest museum yet erected, with all its internal fittings, has not cost so much as a single fully equipped line of battleships, which in a few years may be either at the bottom of the sea or so obsolete in construction as to be worth no more than the material of which it is made.

This principle was well stated more than half a century ago by Edward Edwards in his treatise on the 'Administrative Econ-

omy of the Fine Arts in England,' as follows :

"In addition to the broad principle that public funds can never be better employed than in the establishment of institutions tending at once to refine the feelings and to improve the industry of the whole population, there is the subordinate but yet important ground of inducing and enabling private persons greatly to benefit the public by contributing towards the same end."

"No country," he continues, "has more cause to be proud of that munificent spirit of liberality which leads private individuals to present or bequeath to the community valuable collections which it has been the labor of their lives to form; but to give due effect to this liberality and to make that effect permanent, it is necessary that the state step in and contribute its sanction and its assistance; and in many cases the very munificence of spirit which has formed an immense collection, and given birth to the wish to make it national, has, by its own excess, made that wish powerless without the active aid of the legislature. The actual cost, and still more the inherent value of the collections of Sloane, Elgin and Angerstein, made them in reality gifts to the nation, although they could never have been acquired (without gross injustice to the descendants of the large minded collectors) had not Parliament made certain pecuniary advances on account of them. Whilst but for the foundation of the British Museum and of the National Gallery, the collections of Cracherode and Holwell Carr, of Beaumont, of Sir Joseph Banks and of King George III., would have continued in the hands of individuals."

C. *Public Appreciation of the Higher Function of Museums.*

1. Museums, libraries, reading rooms and parks have been referred to by some wise person as 'passionless reformers,' and no better term can be employed to describe one of the most important of their uses.

The appreciation of the utility of museums to the great public lies at the foundation of what is known as 'the modern museum idea.' No one has written more eloquently of the moral influence of museums than Mr. Ruskin, and whatever may be thought of the manner in which he has carried his ideas into practice in his workmen's museum, near Sheffield, his influ-

ence has undoubtedly done much to stimulate the development of the 'people's museum.' The same spirit inspired Sir Henry Cole when he said to the people of Birmingham in 1874:

"If you wish your schools of science and art to be effective, your health, your air and your food to be wholesome, your life to be long and your manufactures to improve, your trade to increase and your people to be civilized, you must have museums of science and art to illustrate the principles of life, wealth, nature, science, art and beauty."

I myself never shall forget the words of the late Sir Philip Cunliffe Owen, of South Kensington, who said to me some years ago:

"We educate our working people in the public schools, give them a love for refined and beautiful objects, and stimulate in them a desire for information. They leave school, go into the pursuits of town life, and have no means provided for the gratification of the tastes which they have been forced to acquire, and are condemned to a monotonous, depressing life in the midst of smoky chimneys and dingy walls. It is as much the duty of the government to provide them with museums and libraries for higher education as it is to establish schools for their primary instruction."

The development of the modern museum idea is indeed due to Great Britain in much greater degree than to any other nation, and the movement dates from the period of the great Exhibition of 1851, which marked an epoch in the intellectual progress of English speaking peoples.

2. The future of the museum, as of all similar public institutions, is inseparably associated with the continuance of modern civilization, by means of which those sources of enjoyment which were formerly accessible to the rich only are now, more and more, placed in the possession and ownership of all the people (an adaptation of what Jevons has called 'the principle of the multiplication of utility') with the result that objects which were formerly accessible only to the wealthy, and seen by a very small number of people each year, are now held in common ownership and enjoyed by hundreds of thousands.

In this connection the maintenance of museums should be especially favored, because, as has been shown, these, more than any other public agency, are invitations to the wealthy owners of private treasures, in the form of collections, to give them in perpetuity to the public.

3. If it be possible to sum up in a single sentence the principles which have been discussed in the present paper, that sentence should be phrased in these words:

THE DEGREE OF CIVILIZATION TO WHICH ANY NATION, CITY OR PROVINCE HAS ATTAINED IS WELL INDICATED BY THE CHARACTER OF ITS PUBLIC MUSEUMS AND THE LIBERALITY WITH WHICH THEY ARE SUPPORTED.

G. BROWN GOODE.

U. S. NATIONAL MUSEUM.

*THE PROCESSES OF LIFE REVEALED BY THE MICROSCOPE: A PLEA FOR PHYSIOLOGICAL HISTOLOGY.**

It is characteristic of the races of men that almost at the dawn of reflection the first question that presses for solution is this one of life; life as manifested in men and in the animals and plants around them. What and whence is it and whither does it tend? Then the sky with its stars, the earth with its sunshine and storm, light and darkness, stand out like great mountain peaks demanding explanation. So in the life of every human being, repeating the history of its race, as the evolutionists are so fond of saying, the fundamental questions are first to obtrude themselves upon the growing intelligence. There is no waiting, no delay for trifling with the simpler problems; the most fundamental and most comprehensive come immediately to the fore and alone seem worthy of consideration. But as age advances most men learn to ignore the fundamental questions and to sat-

isfy themselves with simpler and more secondary matters as if the great realities were all understood or non-existent. No doubt to many a parent engaged in the affairs of society, politics, finance, science or art, the questions that their children put, like drawing ing aside a thick curtain, bring into view the fundamental questions, the great realities; and we know again that what is absorbing the power and attention of our mature intellect, what perhaps in pride we feel a mastery over, are only secondary matters after all, and to the great questions of our own youth, repeated with such earnestness by our children, we must confess with humility that we still have no certain answers. It behooves us then, if the main questions of philosophy and science cannot be answered at once, to attempt a more modest task and by studying the individual factors of the problem to hope ultimately to put these together and thus gain some just comprehension of the entire problem.

This address is therefore to deal, not with life itself, but with some of the processes or phenomena which accompany its manifestations. But it is practically impossible to do fruitful work according to the Baconian guide of piling observation on observation. This is very liable to be a dead mass devoid of the breath of life. It is a well known fact that the author of the *Novum Organum*, the key which Bacon supposed would serve as the open-sesame of all difficulties and yield certain knowledge, this potent key did not unlock many of the mysteries of science for its inventor. Every truly scientific man since the world began has recognized the necessity of accurate observation, and no scientific principle has ever yet been discovered simply by speculation; but every one who has really unlocked any of the mysteries of nature has inspired, made alive his observations by the imagination, he has, as Tyndall so well put it, made a scientific use of the

* Presidential address delivered before the American Microscopical Society, Wednesday evening, Aug. 21, 1895.

imagination and created for himself what is known as the 'working hypothesis.' It must be confessed that for some investigators the 'hypothesis' becomes so dear that if the facts of nature do not conform to the hypothesis, 'so much the worse for the facts.' But for the truly scientific man, the hypothesis is destined solely to enable him to get the facts of nature in some definite order, an order which shall make apparent their connection with the great order and harmony which is believed to be present in the universe.

If the working hypothesis fails in any essential particular he is ready to modify or discard it. For the truly inspired investigator, one undoubted fact weighs more in the balance than a thousand theories.

At the very threshold of any working hypothesis for the biologist, this question as to the nature of the energy we call life must be considered. The great problem must receive some kind of a hypothetical solution. What is its relation to the energies of light, heat, electricity, chemism and the other forms discussed by the physicist? Are its complex manifestations due only to these or does it have a character and individuality of its own? If we accept the ordinarily received view of the evolution of our solar system, the original fiery nebula in which heat reigned supreme, slowly dissipated part of its heat, and hurled into space the planets, themselves flaming vapors, only the protons of the solid planets. As the heat became further dissipated there appeared in the cooling mass manifestations of chemical attraction, compounds at first gases, then liquids, and finally, on the cooling planets, solids appeared. Lastly, upon our own planet, the earth, when the solid crust was formed and the temperature had fallen below the boiling point of water, the seas were formed and then life appeared. Who could see, in the incandescent nebula, the

liquids and solids of our planet and the play upon them of chemism, of light, heat, electricity, cohesion, tension and the other manifestations so familiar to all? And yet, who is there that for a moment believes that aught of matter or energy was created in the different stages of the evolution? They appeared or were manifested just as soon as the conditions made it possible. So it seems to me that the energy called Life manifested itself upon this planet when the conditions made it possible, and it will cease to manifest itself just as soon as the conditions become sufficiently unfavorable. It was the last of the forms of energy to appear upon this planet, and it will be the first to disappear.

In brief, it seems to me that the present state of physical and physiological knowledge warrants the assumption, the working hypothesis, that life is a form of energy different from those considered in the domain of physics and chemistry. This form of energy is the last to appear upon our planet, last because more conditions were necessary for its manifestations. It, like the other forms of energy, requires a material vehicle through which to act, but the results produced by it are vastly more complex. Like the other energies of nature it does not act alone. It acts with the energies of the physicist, but as the master; and under its influence the manifestations pass infinitely beyond the point where for the ordinary energies of nature it is written 'thus far and no farther.'

It can be stated without fear of refutation that every physiological investigation shows with accumulating emphasis that the manifestations of living matter are not explicable with only the forces of dead matter, and the more profound the knowledge of the investigator the more certain is the testimony that the life energy is not a mere name. And strange to say, the physicist and chemist are most emphatic in de-

claring that life is an energy outside their domain.

The statements of a chemist, a physicist and a biologist are added. From the character and attainments of these men, their testimony, given after years of the most earnest investigation and reflection, is worthy of consideration.

When Liebig was asked if he believed that a leaf or a flower could be formed or could grow by chemical forces, he answered: "I would more readily believe that a book on chemistry or on botany could grow out of dead matter by chemical processes."

"The influence of animal or vegetable life on matter is infinitely beyond the range of any scientific inquiry hitherto entered on. Its power of directing the motions of moving particles, in the demonstrated daily miracle of our human free will, and in the growth of generation after generation of plants from a single seed, are infinitely different from any possible result of the fortuitous concourse of atoms; and the fortuitous concourse of atoms is the sole foundation in philosophy on which can be founded the doctrine that it is impossible to derive mechanical effect from heat otherwise than by taking heat from a body at a higher temperature, converting at most a definite proportion of it into mechanical effect and giving out the whole residue to matter at a lower temperature." Sir William Thomson (Lord Kelvin).

"The anagenetic (vital) energy transforms the face of nature by its power of assimilating and recompounding inorganic matter, and by its capacity for multiplying its individuals. In spite of the mechanical destructibility of its physical basis (protoplasm) and the ease with which its mechanisms are destroyed, it successfully resists, controls and remodels the catagenetic (physical and chemical) energies for its purpose." Cope.

What then are the manifestations of the

life energy? And what are the processes which are discernible? All of us in whatever walk of life will recognize the saying of Gould: "Now when one looks about him the plainest, largest fact he sees is that of the distinction between living and lifeless things."

As life goes on and works with power where the unaided eye fails to detect it, the microscope—marvelous product of the life energy in the brain of man—shows some of these hidden processes. It has done for the infinitely little on the earth what the telescope has done for the infinitely great in the sky.

Let us commence with the little and the simple. If a drop of water from an aquarium, stream or pool is put under the microscope many things appear. It is a little world that one looks into, and like the greater one that meets our eye on the streets, some things seem alive and some lifeless. As we look we shall probably find, as in the great world that the most showy is liable in the end to be the least interesting. In the microscopic world there will probably appear one or more small rounded masses which are almost colorless. If one of these is watched, lo, it moves, not by walking or swimming, but by streaming itself in the direction. First a slender or blunt knob appears, then into it all of the rest of the mass moves, and thus it has changed its position. If the observation is continued, this living speck, which is called an amoeba, will be seen to approach some object and retreat; indeed, it comports itself, as if sensitive, with likes and dislikes. If any object suitable for food is met in its wanderings the living substance flows around it, engulfs it and dissolves the nutrient portions and turns them into its own living substance; the lifeless has been rendered alive. If the eye follows the speck of living matter, the marvels do not cease. After it has grown to a certain size, as if by an invisible string, it

constricts itself in the middle and finally cuts itself in two. The original amoeba is no more; in its place there are two. Thus nearly at the bottom of the scale of life are manifested all of the fundamental features, the living substance moves itself, takes nourishment, digests it and changes non-living into living substance and increases in size; it seems to feel and to avoid the disagreeable and choose the agreeable and finally it performs the miracle of reproducing its kind, of giving out its life and substance to form other beings, its offspring.

It is the belief of many biologists that the larger and complex forms even up to man himself may be considered an aggregation of structural elements originally more or less like the amoeba just described; but instead of each member of the colony, each individual itself carrying on all the processes of life independently as with the amoeba, there is a division of labor. Some move, some digest, some feel, think and choose, some give rise to new beings, all change lifeless matter into their own living substance.

The processes and phenomena by which a new individual is produced are included under the comprehensive term, Embryology.

All organisms, great or small, are but developments of minute germs budded off by the parent or parents, and the way in which these minute beginnings develop into perfect forms like their parents can only be followed by the aid of a microscope. Indeed, in no field of biology has the microscope done such signal service in revealing the processes of life.

The method of the production of a new being with the amoeba, as we have just seen, is for the parent to give itself entire to its offspring—the parent ceasing to be in producing its offspring. With some other lowly forms a part of the body of the parent buds out, grows and finally falls off as an independent organism, or remains con-

nected with the parent to form a colony. In the plant world a familiar example of a colony is represented by the cactus that the children call 'Old Hen and Chickens.'

In the higher animals, however, where specialization has been carried to its extreme limit, some myriads of cells forming the body are set apart to produce motion, others digest food, still others think and feel, while comparatively few, the *germ cells* are destined for the continuation of the race. In the higher and highest forms especially, all observation goes to show that the life energy, not satisfied with the mere vitalization of matter and a dead level of excellence, is aiming at perpetual ascent, greater mastery over matter and its physical forces. For the more certain attainment of this end, the production of offspring is no longer possible for one individual; two wholly separate individuals must join, each contributing its share of the living matter which is to develop into a new being. In this way the accumulated acquisitions of two are united with the consequent increase in the tendencies and impulses for modification, and nearly double the protection for the offspring. Thus in striking contrast with the amoeba, where the single parent gives all of itself to form offspring, and in so doing disappears and loses its individuality, the higher forms, while two must unite to form the offspring, the parents remain and retain their individuality and the ability to produce still other offspring. The process by which this is accomplished may be traced step by step with the microscope. A germ cell of the father and one of the mother fuse together, and from this new procreative cell, formed by the fusion of two with all their possibilities combined, the new individual arises. This certain knowledge is the result of the profound investigation of the last few years and shows the literalness of the scriptural statement, 'they shall be one flesh.'

After this fusion of the father and mother germ cells, the single cell thus formed, like the amoeba, divides into two, and these into four and so on, but unlike the amoeba all the cells remain together. Within this cellular mass, as if by an unseen builder, the cells are deftly arranged in their place, some to form brain, some heart, some the digestive tract, others for movement, so that finally from the simple mass of cells, originally so alike, arises the complex organism, fish or bird, beast or man. How perfectly the word *offspring* describes the life process in the production of this new being! That the child should resemble both father and mother is thus made intelligible, for it is a part of both. Yes, further, it may resemble grandfather or great grandfather or mother, for truly it is a part of them, their life conserved and continued. There is no new life, it is only a continuation of the old: '*Omne vivum ex vivo*,' all life from life. But the demonstration of this prime fact required a microscope, and it is an achievement of the last half of this century. How counter this statement still is to the common belief of mankind we may perhaps better appreciate if we recall our own youth, and remember with what absolute confidence we expected the stray horsehairs we had collected and placed in water to turn into living snakes. The belief that it is an every-day occurrence for living beings to arise from lifeless matter was not by any means confined to those uneducated in biology. It was held by many scientific men within the memory of most of us. Indeed, this goblin of *spontaneous generation*, even for the scientific world, has been laid low so recently that the smoke of battle has scarcely yet cleared from the horizon.

In the complex body of animals, as stated above, the constituent elements perform different functions. Is there any hint of the way in which the action is accomplished?

Let us glance at two systems, the nervous and the glandular, widely different in structure and function. All know how constantly the glands are called into requisition, the salivary glands for saliva, those of the stomach and pancreas for their digestive juices, etc. If we take now the pancreas as an example, and that of a living fasting animal is put under the microscope so that its constituent cells can be observed, it will be seen that they are clouded, their outlines and that of their nuclei being very vague and indistinct. The cell is apparently full of coarse grains. If now the animal is fed, as the digestion proceeds the pancreas pours out its juice. At the same time the granules and with them the cloudiness gradually disappear, the cells become clear and both they and their nuclei are sharply outlined. That is, the substance which is to form the pancreatic juice is stored in the cells in the form of granules during the periods of rest and held until the digestive agent is demanded, and if the demand is great all the granules may be used up. But as soon as the demand ceases the cells begin again their special vital action, and again the granules begin to appear and increase in number until finally the cells become so full that they are fully charged and again ready to pour forth the digestive fluid. This is a daily, almost an hourly process. Let us take another example in which there would almost appear an organic memory on the part of the gland cells. No doubt all have seen the clear jelly-like masses surrounding the eggs of frogs and salamanders. Whence comes this jelly that is so resistant to the agents that work so quickly the destruction of ordinary organic matter? As spring advances the cells of the oviduct increase enormously in size. The microscope shows this increase to be due to a multitude of clear granules. As the eggs move along, the ova are coated with the jelly formed from the granules

given out by the cells. As this material for the jelly is poured out the cells gradually shrink to their original size, and then wait another twelve months before doing their destined work.

If one can thus catch a glimpse of some of the finer processes taking place in gland action, how is it with nervous action, the highest function of which living matter is capable? While it has been known for a long time that the nervous system is the organ of thought and feeling and the director and coördinator of the motions of the body, and many speculations have been made concerning the processes through which the nervous tissue passes in performing its functions, it was left to an American student, Dr. Hodge, to first successfully show that there were visible changes through which the nervous system passes in its work. The question is, can the activity of the nervous system be traced as surely by changes occurring in the living matter forming its basis as the action of a gland can be seen by the study of the gland cells?

The demonstration is simple now that the method has been shown. No doubt every one has had the experience of failing to perform some difficult muscular action at one time and then at another of doing it with ease, or of finding true the reverse of the adage 'practise makes perfect.' For example, in a trial of skill, as in learning to ride a bicycle, all the complicated action may be performed with considerable ease and certainty when one is fresh, but as the practice continues the results become progressively less and less successful, and finally with increasing weariness there is only failure and one must rest. We say the muscles are tired; this is true in part, but of much greater importance is the fatigue of the nervous system, as this furnishes the impulses for the action and coördination of the muscles. Now, as muscular

action can be seen and the amount can be carefully controlled, here was an exact indicator of the time and amount of the nervous activity. Furthermore, as animals have two similar sides, one arm or leg may work and the other remain at rest, and consequently corresponding sides of the nervous system may be active and at rest. By means of electrical irritation one arm of a cat or other animal was caused to move vigorously for a considerable time, the other arm remaining at rest. Then the two sides of the nervous system, that is the pairs of nerves to the arms with their ganglia and a segment of the myel (spinal cord), were removed and treated with fixing agents, and carried through all the processes necessary to get thin sections capable of accurate study with the microscope. Finally, upon the same glass slide are parts of the nervous system fatigued even to exhaustion, and corresponding parts of the same animal which has been at rest. Certainly if the nervous substance shows the result or processes of its action the conditions are here perfect. Fatigued nerve cells are side by side with those in a state of rest. The appearances are clear and unmistakable; the nucleus has markedly decreased in size in the fatigued cells and possesses a jagged irregular outline in place of the smooth rounded form of the resting cells. The cell substance is shrunken in size and possesses clear scattered spaces or a large clear space around the nucleus.

If the nervous substance was not fixed at once, but remained in the living animal for twelve to twenty-four hours in a state of repose, the signs of exhaustion disappeared and the two sides appeared alike. By studying preparations made after various periods of repose all the stages of recovery from exhaustion could be followed.

For possible changes in normal fatigue sparrows, pigeons and swallows and also honey bees were used. For example, if

two sparrows or two honey bees as nearly alike as possible were selected, the nervous system of one being fixed in the morning after the night's rest and that of the other after a day of toil, the changes in the cells of the brain of the honey bee or sparrow and in the spinal ganglia of the sparrow were as marked as in case of artificial fatigue. After prolonged rest then the nerve cells are *charged*, so to speak—they are full and ready for labor, but after a hard day's work they are *discharged*, shrunken and exhausted.

There is one more step in this brilliant investigation. If in the morning after sleep and rest animals and men are full of vigor, and in the evening are weary and exhausted, how like is it to the beginning and end of life? In youth so overflowing with vigor that to move, to act, is a pleasure and continued rest a pain. But in the evening of life a warm corner and repose are what we try to furnish those whose work is done. How is this correlated in the cells of the nervous system with the states of rest and fatigue? With a well-nourished child which died from one of the accidents of birth the nerve cells showed all the characters of cells at rest and fully charged. In a man dying naturally of old age the cells showed the shrunken nuclei and all the appearances of exhausting fatigue. In the one was the potentiality of a life of vigorous action; the other showed the final fatigue—the store of life-energy had been dissipated and there was no recovery possible.

For the animals that possess an undoubted nervous system probably all would admit that there is some sort of nervous action corresponding to sensation; but what of living matter in the humbler forms where no nervous system can be found? That these have vital motion, that they breathe, nourish themselves, grow and produce offspring, none can deny. Do they

have anything comparable with sensation? As most of the lower forms are minute, the microscope comes to our aid again, and in watching these lowliest living beings it is found that they discriminate and choose going freely into some portions of their liquid world and withdrawing from other portions. If some drug which is unusual, or we must believe disagreeable, is added to a part of the water they withdraw from that part. It seems to have the same effect as disagreeable odors on men and animals. On the other hand, there are substances which attract, and into the water containing these they enter with eagerness. Strange is it too that as proved by experiment if an unattractive substance is used, and also one on the other side that has been still more attractive, the less disagreeable is selected, the less of two evils is chosen.

As man, the horse, dog and many other animals adapt themselves gradually to temperatures either very cold or very warm, and that too by a change in their heat-regulating power rather than by a change of hairy or other clothing, so these lowly organisms are found in nature in water at temperatures from near freezing up to 60°–80° C., a point approaching that of boiling water. It may be answered that each was created for its place; but by means of a microscope and a delicate thermostat, to be certain of every step and to see all the results, Dr. Dallinger through a period of seven years accustomed the same unicellular organism and its progeny to variations of temperature from 15°–20° C., *i. e.*, about the temperature of a comfortable sitting-room, up to 70° C. For those at the cooler temperature it was death to increase rapidly the temperature 10°, and for those at the higher temperature it was equally fatal to lower the heat to 15°–20°, their original normal temperature. These examples seem to show that it is one of the fundamental character-

istics of living substances, whether in complex or simple forms, to adapt themselves to their environment.

There is another fact in nature that the microscope has revealed and that fills the contemplative mind with wonder and an aspiration to see a little farther into the living substance, and so perchance discover the hidden springs of action. This fact may be called *cellular altruism*. In human society the philanthropist and soldier are ready at any time to sacrifice themselves for the race or the nation. With the animals the guards of the flock or herd are equally ready to die in its defense.

So within each of the higher organisms the microscope has shown a guarding host, the leucocytes or white blood corpuscles. The brilliant discoveries in the processes of life with higher forms have shown that not only is there a struggle for existence with nature and against forms as large or larger than themselves, but each organism is liable to be undermined by forms, animal and vegetable, infinitely smaller than themselves, insignificant and insidious but deadly. Now to guard the body against these living particles and the particles of dust that would tend to clog the system there is a vast army of amœba-like cells, the leucocytes, that go wherever the body is attacked and do battle. If the guards succeed the organism lives and flourishes, otherwise it dies or becomes weakened and hampered. This much was common scientific property three years ago, when one of our members (Miss Edith J. Claypole) came to my laboratory for advanced work. I discussed with her what has just been given, and told her that there still remained to be solved the problem what becomes of the clogging or deleterious material which the leucocyte take up? These body guards are after all a part of the organism, and for them simply to engulf the material would not rid the body entirely of it, and finally

an inevitable clogging of the system would result. The problem is simple and definite: What becomes of the deleterious substances, bacteria and dust particles, that get into the body and become engulfed by the leucocytes? Fortunately, for the solution of this problem, in our beautiful Cayuga Lake there is an animal, the *Necturus*, with external gills through which the blood circulates for its purification. So thin and transparent is the covering tissue in these gills that one can see into the blood stream almost as easily as if it were uncovered. Every solid constituent of the blood, whether red corpuscle, white corpuscle, microbe or particle of dust, can be seen almost as clearly as if mounted on a microscopic slide.

Into the veins of this animal was injected some lampblack mixed with water, a little gum arabic and ordinary salt, an entirely non-poisonous mixture. Thousands of particles of carbon were thus introduced into the blood and could be seen circulating with it through the transparent gills. True to their duty, the white corpuscles in a day or two engulfed the carbon particles, but for several days more the leucocytes could be seen circulating with the blood stream and carrying their load of coal with them. Gradually the carbon laden corpuscles disappeared and only the ordinary carbon-free ones remained. Where had the carbon been left? Had it been simply deposited somewhere in the system? The tissues were fixed and serial sections made. The natural pigment was bleached with hydrogen-dioxid, so that if any carbon was present it would show unmistakably. With the exception of the spleen, no carbon appeared in the tissues, but in many places the carbon-laden leucocytes were found. In mucous cavities and on mucous surfaces and on the surface of the skin were many of them; in the walls of organs were many more apparently on their way to the surface with the load, that is the carbon is

actually carried out of the tissues upon the free surfaces of the skin and mucous membranes where, being outside of the body, it could no more interfere in any way with it. But what was the fate of the leucocytes that carried the lampblack out of the tissues? They carry their load out and free the body, but they themselves perish. They sacrifice themselves for the rest of the body as surely as ever did soldier or philanthropist for the betterment or the preservation of the state.

Thus I have tried to sketch in briefest outline some of the phenomena or processes of life revealed by the microscope. Most of those discussed have come under my own personal observation and are therefore to me particularly real and instructive. But to every one long familiar with the microscope and with the literature of biology, many other examples will occur, some of them even more striking. This discussion has been confined to the above also because it seems to me to show with great clearness the way in which we can justifiably hope to do fruitful work in the future. This sure way it seems to me is the study of structure and function together; the function or activity serving as a clue and stimulus to the investigator for finding the mechanism through which function is manifested and thus give due significance to structural details which, without the hint from the function, might pass unnoticed.

This kind of microscopical study, it seems to me, may be well designated as *Physiological History*. It is in sharp contrast with ordinary histology, in which too often the investigator knows nothing of the age, state of digestion or of fasting, nervous activity, rest or exhaustion. Indeed, in many cases it is a source of congratulation if he knows even the name of the animal from which the tissue is derived. Such haphazard observation has not in the past, and is not likely in the future, to lead to splen-

did results. If structure, as I most firmly believe, is the material expression of function, and the sole purpose of the structure is to form the vehicle of some physiological action, then the structure can be truly understood only when studied in action or fixed and studied in the various phases of action.

Indeed, if one looks only for form or morphology in the study of histology, the very pith and marrow is more than likely to be lost.*

For example, if one wished to study the comparative histology of the pancreas and were to take pieces from various animals to be compared without regard to their condition of fasting or digestion, he might find the coarser anatomical peculiarities in each. In all probability he would also find two distinct structural types, with various gradations. One type with clearly defined cells and nuclei, the other with the cells clouded, filled with granules and with the outlines of cells and their nuclei almost indiscernible. Between these there might be various gradations in the different forms. And yet, from what has been stated above, it is plain that all these different structural appearances represent phases of activity, and all might have come from the selfsame animal. In like manner, if certain parts of

*Although in a different field, the words of Osborn in discussing the unknown factors of evolution are so pertinent that they may well be quoted: "My last word is that we are entering the threshold of the evolution problem, instead of standing within the portals. The hardest tasks lie before us, not behind us." "We are far from finally testing or dismissing these old factors [of evolution], but the reaction from speculation upon them is in itself a silent admission that we must reach out for some unknown quantity. If such does exist there is little hope that we shall discover it except by the most laborious research; and while we may predict that conclusive evidence of its existence will be found in morphology, it is safe to add that the fortunate discoverer will be a physiologist, 'armed with a microscope.' I would like to add" *Am. Nat.*, May, 1895.

the nervous system were to be studied comparatively, and the tissue taken from one animal after refreshing sleep and rest, from another after exhausting labor, another in infancy, and another from an animal decrepit with years, the difference in general appearance and in structural details would be striking enough to satisfy any morphologist that, as with the structure of the pancreatic cells, there were two or more distinct types; but the physiological histologist would recognize at once that the differences so much insisted upon represented different phases of activity, and, as with the pancreatic cells, might be all represented in the same animal at different times.

I would be far from saying that there are no structural differences in the different animals independent of any particular phase of functional activity; but if these only are sought and the others neglected, the physiological appearances will often obtrude and confuse, if they do not utterly confound.

I have therefore for the last ten years urged my students, and mean to go on advocating with all the earnestness of which I am capable, that, in studying an organism or its tissues, the investigator, to gain certain knowledge, must know all that it is possible to learn concerning the age, health, state of nervous, muscular and digestive activity; in fact, all that it is possible to find out about the processes of life that are going on and have gone on when the study is made.

Fortunately, there are some microscopic forms in which the entire study can be made while the creature is alive. With the higher organisms also some of the living elements, as the white corpuscles, can be studied and their various actions and structural changes observed for a considerable time. Most of the tissues of the higher forms, however, cannot be thus studied,

and the best that can be done is to fix the different phases of action, as by a series of instantaneous photographs, then with a kind of mental kinetoscope put these together and try to comprehend the whole cycle.

Fortunately for the histologist the incessant experimentation of the last twenty-five years has brought to knowledge chemical substances which do for the tissues the wonder that was ascribed to the mythical Gorgon's head—to kill instantly and to harden into changeless permanence all that gazed upon it. So the tissues may be fixed at any phase, and then studied at length. If then the investigator observes and keeps record of every point that may have an influence on the structural appearances, whether shown by experience or suggested by insight, and this record always accompanies the specimen, thus and thus only, it seems to me, can he feel confident that he is liable to gain real knowledge from the study, knowledge that represents actuality and which will serve as the basis for a newer and more complete unraveling of the intricacies of structure, an approximate insight into the mechanism through which the life energy manifests itself.

And so, with all the light that physics and chemistry can give, commencing with the simplest problems and being careful that every factor that can influence the result is being duly considered, the microscopist can go forward with enthusiasm and with hope, not with the hope that the great central question can be answered in one generation, perhaps not in a thousand, but confident that if each one adds his little to the *certain* knowledge of the world, then in the fullness of time the knowledge of living substance and the life processes will be so full and deep that what *life is*, though unanswered, may cease to be the supreme question.

SIMON HENRY GAGE.

CORNELL UNIVERSITY.

CONSCIOUSNESS AND EVOLUTION.

THE quotation by Professor Cattell in SCIENCE, July 26, of Professor Cope's table (from the *Monist*, July, 1895) shows that he was equally struck by it with myself. Prof. Cope gives in this table certain positions on points of development, in two contrasted columns, as he conceives them to be held by the two camps of naturalists divided in regard to inheritance into Preformists and the advocates of Epigenesis. The peculiarity of the Epigenesis column is that it includes certain positions regarding consciousness, while the Preformist column has nothing to say about consciousness. Being struck with this I wrote to Professor Cope—the more because the position ascribed to consciousness seemed to be the same, in the main, as that which I myself have recently developed from a psychological point of view in my work on *Mental Development* (Macmillan & Co.). I learn from him that the table* is not new; but was published in the 'annual volume of the Brooklyn Ethical Society in 1891:' and the view which it embodies is given in the chapter on 'Consciousness in Evolution;' in his *Origin of the Fittest* (Appletons, 1887).

Apart from the question of novelty in Professor Cope's positions—and that Mr. Cattell and I should both have supposed them so can only show that we had before read hastily; I myself never looked into Professor Cope's book until now—I wish to point out that the placing of consciousness, as a factor in the evolution process, exclusively in the Epigenesis column, appears quite unjustified. It is not a question, as Mr. Cattell seems to intimate in his note referred to in SCIENCE, July 26, of a causal interchange between body and mind. I do not suppose that any naturalist would hold to an injection of energy in any form into

the natural processes by consciousness; though, of course, Professor Cope himself can say whether such a construction is true in his case. The psychologists are, as Mr. Cattell remarks, about done with a view like that. The question at issue when we ask whether consciousness has had a part in the evolutionary process is, I think, as to whether we say that the presence of consciousness—say in the shape of sensations of pleasure and pain—with its nervous or organic correlative processes, has been an essential factor in evolution; and if so, further, whether its importance is because it is through the consciousness aspect of it that the organic aspect gets in its work. Or, to take a higher form of consciousness, does the memory of an object as having given pleasure help an organism to get that object a second time? This may be true, although it is only the physical basis of memory in the brain that has a causal relation to the other organic processes of the animal.

Conceiving of the function of consciousness, therefore, as in any case not a *deus ex machina*, the question I wish to raise is whether it can have an essential place in the development process as the Preformists construe that process. Professor Cope believes not. His reasons are to appear fully in his proposed book. I believe that the place of consciousness may be the same—and may be the essential place that Mr. Cope gives it in his left-hand column and which I give it in my *Mental Development*—on the Preformist view. I have argued briefly for this indifference to the particular theory one holds of heredity, in my book (Chap. VII.), reserving for a further occasion certain arguments in detail based upon the theory of the individual's personal relation to his social environment. The main point involved, however, may be briefly indicated now, although, for the details of the social influences appealed to, I must again refer

*This table is given in the issue of SCIENCE for July 26, p. 100. The three points from it which are taken up now are cited below.

to my book (Chaps. on 'Suggestion' and 'Emotion').

I have there traced out in some detail what other writers also have lately set in evidence, *i. e.*, that in the child's personal development, his ontogenesis, his life history, he makes a very faithful reproduction of his social conditions. He is, from childhood up, excessively receptive to social suggestion; his entire learning is a process of conforming to social patterns. The essential to this, in his heredity, is excessive instability, cerebral balance and equilibrium, a readiness to overflow into the new channels which his social environment dictates. He has to learn everything for himself, and in order to do this he must begin in a state of great plasticity and mobility. Now, my point, but briefly, is that these social lessons which he learns for himself take the place largely of the heredity of particular paternal acquisitions. The father must have been plastic to learn, and this plasticity is, as far as evidence goes, the nervous condition of acute consciousness; the father then learned, through his consciousness, from his social environment. The child does the same. What he inherits is nervous plasticity and the consciousness. He learns particular acts for himself; and what he learns is, in its main line, what his father learned. So he is just as well off, the child of Preformism, as if he had been the heir of the particular lessons of his father's past. I have called this process 'Social Heredity,' since the child really inherits the details; but he inherits them from society by this process of social growth, rather than by direct natural inheritance.

To show this in a sketchy way, I may take the last three points which Professor Cope makes under the Epigenesis column, the points which involve consciousness, and show how I think they may still be true to the Preformist if he avail himself of the resource offered by 'Social Heredity.'

I do this rather for convenience than with any wish to controvert Professor Cope; and it may well be that his later statements may show that even this amount of reference to him is not justified.

1. (5 of Cope's table.) "Movements of the organism are caused or directed by sensation and other conscious states."

The point at issue here between the advocate of Epigenesis and the Preformist would be whether it is necessary that the child should inherit any of the particular conscious states, or their special nervous dispositions, which the parent learned in his lifetime, in order to secure through them the performance of the same actions by the child. I should say, no; and for the reason—additional to the usual arguments of the Preformists—that 'Social Heredity' will secure the same result. All we have to have in the child is the high consciousness represented by the tendency to imitate the parent or to absorb social copies, and the general law now recognized by psychologists under the name of Dynamogenesis—*i. e.*, that the thought of a movement tends to discharge motor energy into the channels as near as may be to those necessary for that movement.* Given these two elements of endowment in the child, and he can learn anything that his father did, without inheriting any particular acts learned by the parent. And we must in any case give the child this much; for the principle of Dynamogenesis is a fundamental law in all organisms, and the tendency to take in external 'copies' by imitation, etc., is present in all social animals, as a matter of fact.

The only hindrance that I see to the child's learning everything that his life in society requires would be just the thing that the advocates of Epigenesis argue for—the inheritance of acquired characters. For such inheritance would tend so to bind

* Both of these requirements are worked out in detail in my book.

up the child's nervous substance in fixed forms that he would have less or possibly no unstable substance left to learn anything with. So, in fact, it is with the animals in which instinct is largely developed; they have no power to learn anything new, just because their nervous systems are not in the mobile condition represented by high consciousness. They have instinct and little else. Now, I think the Preformist can account for instinct also, but that is beside the point; what I wish to say now is that, if Epigenesis were true, we should all be, to the extent to which both parents do the same acts (as, for example, speech) in the condition of the creatures who do only certain things and do them by instinct. I should like to ask of the Neo-Lamarckian: What is it that is peculiar about the strain of heredity of certain creatures that they should be so remarkably endowed with instincts? Must he not say in some form that the nervous substance of these creatures has been 'set' in the creatures' ancestors? But the question of instinct is touched upon under the next point.

2. (6 of Cope's table.) "Habitual movements are derived from conscious experience." This may mean movements habitual to the individual or to the species in question. If it refers to the individual it may be true on either doctrine, provided we once get the child started on the movement—the point discussed under the preceding head. If, on the other hand, habitual movements mean race movements, we raise the question of race habits, best typified in instinct. I agree with Mr. Cope that most race habits are due to conscious function in the first place; and making that our supposition, again we ask: Can one who believes it still be a Preformist? I should again say that he could. The problem set to the Preformist would not in this case differ from that which he has to solve in accounting for development generally:

it would not be altered by the postulate that consciousness is present in the individual. He can say that consciousness is a variation, and what the individual does by it is 'preformed' in this variation. And then what later generations do through their consciousness is all preformed in the variations which they constitute on the earlier variations. In other words, I do not see that the case is made any harder for the Preformist by our postulate that consciousness with its nervous correlate is a real agent. And I think we may go further and say that the case is easier for him when we take into account the phenomena of Social Heredity. In children, for example, there are variations in their mobility, plasticity, etc.; in short, in the ease of operation of Social Heredity as seen in the acquisition of particular functions. Children are notoriously different in their aptitudes for acquiring speech, for example; some learn faster, better, and more. Let us say that this is true in animal communities generally; then these most plastic individuals will be preserved to do the advantageous things for which their variations show them to be the most fit. And the next generation will show an emphasis of just this direction in its variations. So the fact of Social Heredity—the fact of acute use of consciousness in ontogeny—becomes an element in phylogeny, also, even on the Preformist theory.

Besides, when we remember that the permanence of a habit learned by one individual is largely conditioned by the learning of the same habits of others (notably of the opposite sex) in the same environment, we see that an enormous premium must have been put on variations of a social kind—those which brought different individuals into some kind of joint action or coöperation. Wherever this appeared, not only would habits be maintained, but new variations, having all the force of double he-

editary tendency, might also be expected. But consciousness is, of course, the prime variation through which coöperation is secured. All of which means, if I am right, that the rise of consciousness is of direct help to the Preformist in accounting for race habits—notably those known as gregarious, coöperative, social.

3. (7 of Cope's table.) "The rational mind is developed by experience, through memory and classification." This, too, I accept, provided the term 'classification' has a meaning that psychologists agree to. So the question is again: Can the higher mental functions be evolved from the lower without calling in Epigenesis? I think so. Here it seems to me that the fact of Social Heredity is the main and controlling consideration. It is notorious how meagre the evidence is that a son inherits or has the peculiar mental traits of parents beyond those traits contained in the parents' own heredity. Galton has shown how rare a thing it is for artistic, literary or other marked talent to descend to the second generation. Instead, we find such exhibitions showing themselves in many individuals at about the same time, in the same communities, and under the same social conditions, etc. Groups of artists, musicians, literary men, appear, as it were, a social outburst. The presuppositions of genius—dark as the subject is—seem to be great power of learning or absorbing, marked gifts or proclivities of a personal kind which are not directly inherited but fall under the head of sports or variations, and then a social environment of high level in the direction of these sports. The details of the individual development, inside of the general proclivity which he has, are determined by his social environment, not by his natural heredity. And I think the phylogenetic origin of the higher mental functions, thought, self-consciousness, etc., must have been similar. I have devoted

space to a detailed account of the social factors involved in the evolution of these higher faculties in my book.

I fail to see any great amount of truth in the claims of Mr. Spencer that intellectual progress in the race requires the Epigenesis view. The level of culture in a community seems to be about as fixed a thing as moral qualities are capable of being; much more so than the level of individual endowment. This latter seems to be capricious or variable, while the former moves by a regular movement and with a massive front. It would seem, therefore, that intellectual and moral progress is gradual improvement, through improved relationships on the part of the individuals to one another; a matter of social accommodation, rather than of natural inheritance alone, on the part of individuals. It is only a rare individual whose heredity enables him to break through the lines of social tissue and imprint his personality upon the social movement. And in that case the only explanation of him is that he is a variation, not that he inherited his intellectual or moral power. Furthermore, I think the actual growth of the individual in intellectual stature and moral attainment can be traced in the main to certain of the elements of his social *milieu*, allowing always a balance of variation in the direction in which he finally excels.

So strong does the case seem for the Social Heredity view in this matter of intellectual and moral progress that I may suggest an hypothesis which may not stand in court, but which I find interesting. May not the rise of the social life be justified from the point of view of a second utility in addition to that of its utility in the struggle for existence as ordinarily understood, the second utility, *i. e.*, of giving to each generation the attainments of the past which natural inheritance is inadequate to transmit? Whether we admit Epigenesis or

confine ourselves to Preformism, I suppose we have to accept Mr. Galton's law of Regression and Weismann's principle of Panmixia in some shape. Now when social life begins we find the beginning of the artificial selection of the unfit; and so these negative principles begin to work directly in the teeth of progress, as many writers on social themes have recently made clear. This being the case, some other resource is necessary besides natural inheritance. On my hypothesis it is found in the common or social standards of attainment which the individual is fitted to grow up to and to which he is compelled to submit. This secures progress in two ways: First, by making the individual learn what the race has learned, thus preventing social retrogression, in any case; and second, by putting a direct premium on variations which are socially available.

Under this general conception we may bring the biological phenomena of infancy, with all their evolutionary significance: the great plasticity of the mammal infant as opposed to the highly developed instinctive equipment of other young; the maternal care, instruction and example during the period of helplessness, and the very gradual attainment of the activities of self-maintenance in conditions in which social activities are absolutely essential. All this stock of the development theory is available to confirm this view.

And to finish where we began, all this is through that wonderful engine of development, consciousness. For consciousness is the avenue of all social influences.

J. MARK BALDWIN.

PRINCETON.

THE SCIENCE OF EXAMINING.

MUCH severe criticism is being directed against examinations, and much of it is timely and fully deserved. And yet when the criticisms are carefully considered they

appear to be directed not so much against examinations as a method in education as against certain forms of examination which are very prevalent and which certainly do not show anything more than evanescent memorization, adroitness or trickiness on the part of a student. No one will deny, however, that much of actual life is a kind of examination, and that we are being continually pressed to solve problems of all kinds, apply knowledge, and in general to act, and that on the success of our efforts will depend the positions we will attain, or, at least, maintain. There seems to be no reason why examinations should not be made an extremely important part of education, instead of being, as I fear they often are, an unmitigated nuisance to both student and teacher, a bone for the pedagogical critics continually to snarl over, and, when all is done, to be of no real use to either teacher or student, and to show nothing as to the real nature of the teaching done and the mental development of the student.

For the teacher who teaches from love of teaching, and who knows that successful teaching calls for the application of psychological principles far more than is generally supposed, there is a peculiar fascination in an examination paper. An examination may be made a test of the contents, capacity, quality and action of a mind under defined conditions; but the paper must be a good one; I do not refer to the work of an inexperienced hand. The idea seems to be prevalent that anyone can write an examination paper. This is a great mistake. The elaboration of a paper that will really test not only the contents of the mind, but also its different functions as developed by a particular study under the guidance of a particular teacher, requires experience and ability. It is true that a man may be a good teacher and a poor examiner, but this usually arises from a lack of attention to the science and art of examining. My ex-

perience in this branch of pedagogical science leads me to believe that there are not very many really good examiners, and that the average examinations do not test the minds of the student as they ought to be tested. The average examination calls mainly for an exercise of memory, and for some proof that the student understands the matter he has studied. No man values the faculty of memory more highly than I do, or requires a better understanding of a given subject. But memory and mere understanding are only the foundations of education. More than this is called for. Some examinations require skill in observation, others accurate definition; while others bristle with problems. Some call for knowledge in which the teacher is weak. Almost every pedagogic earmark may be found in examination papers, but rarely is the paper constructed on such a plan that it tests not only the quality and quantity of knowledge in the mind, but also the various workings of the mind, and ascertains what the mind can do when set in action by the particular subject.

In my own specialty of chemistry there is an excellent opportunity for examination papers, which may test the mind qualitatively and quantitatively, and probe both absorptive and productive powers. I have always taken a great interest in working out examination papers and in studying the minds as they appear in the answers. I am accustomed to work out questions under various heads. The following examples will serve to indicate my meaning, and may also encourage others to experiment in examinational science; and I think that the method will be found so interesting that the investigation will not be hastily dropped. I should add that in the examination paper as given to the students the questions are mixed up, so that the classifications given as follows do not appear.

QUESTIONS FOR TESTING:—

Memory.—(1) Give a brief history of oxygen. (2) Outline the theory of phlogiston. (3) What are 'coppers;' 'bluestone,' 'tincal.'

Accuracy of Definition.—(4) State concisely the laws of Dalton, Charles, Mariotte and Avogadro. (5) Define a mechanical mixture. (6) Define an element.

Observation of Experimentally Demonstrated Facts.—(7) Describe and sketch an apparatus for producing acetylene from calcium carbide and explain the working of it. (8) Describe and sketch the combustion of nitric acid in iodohydric acid.

Accuracy of Detail.—(9) Explain with the aid of sketches the reduction of hot cupric oxide by hydrogen, heating the oxide in a combustion-furnace and preparing the hydrogen in a Kipp generator.† (10) Make a sketch of a section of Pepp's gasometer, and explain how the apparatus works.

Acquaintance with the Properties of Matter.—(11) Describe the properties and chemical behavior of nitrogen, sulfur, zinc, silica and iodine.

Retention of Oral Instruction.—(12) Explain the contamination of water by sewage. (13) Describe the process for making open hearth steel.

The Faculty of Comparison.—(14) State similarities and differences between the properties of oxygen and hydrogen. (15) What substances resemble lead sulfide in color and solubility in nitric acid.

Lucidity of Statement.—(16) Describe minutely and without sketches the apparatus and method of preparing phosphine. (17) Prove by analysis of stibine by volume that the molecule of antimony is tetraatomic.

Recognition of Substances.—(18) A yellowish green gas with a suffocating odor. What may it be? (19) A colorless gas, very soluble in water, gives white fumes with hydrochloric acid. What may it be? (20) A white powder, insoluble in water; heated with concentrated nitric acid it evolves red fumes and yields a solution, which, when excess of acid is evaporated off, and it is diluted with water, yields a precipitate which is insoluble in concentrated nitric acid. What may this white substance be? (21) A chemist wishes to fill a jar with red liquid. What substance may he use?

The Ability to Observe.—(22) Give four examples of chemical change which you observe in this room. (23) Describe an ordinary red building brick, stating dimensions and properties of surface, weight, fracture, etc. (24) Water expands on freezing. Give five examples of results caused by this expansion which you have personally observed.

* Given in lectures and not in text-book.

† Given in text-book and demonstrated in lecture.

The Application of Facts to Proofs. (25) Prove that water is formed by the combustion of a kerosene lamp. (26) Prove that hydrogen sulfid contains sulfur.

The Interpretation of Phenomena.—(27) A piece of white paper on being held for an instant in the flame of a candle and at right angles to it, a black ring is formed on the paper. Explain what the ring indicates, and how the particles of carbon are formed and why they are deposited on the paper. (28) A Roman candle on being ignited and then thrust under water continues to burn. How can this be accounted for? (29) Why cannot fish live in lakes on the tops of very high mountains.*

The Application of Knowledge.—(30) The iodine falls into the sand box. How can the iodine and sand be separated? (31) A mixture consists of barium carbonate, sodium sulfate and sulfur. How can they be separated? (32) A manufacturer has a waste product consisting of a liquid containing 40 % of sulfuric acid, 10 % sodium sulfate and 5 % ferric sulfate. How can he treat it so as to convert it into other products that have commercial value?

Deceptive or Misleading Questions.—(33) Dilute sulfuric acid is poured upon zinc. A gas with a slight bluish* color is evolved which burns with a red† flame. What is it? (34) Chlorine gas is collected in a jar over mercury‡ in the usual manner. It is then brought into a eudiometer, mixed with twice§ its volume of hydrogen, and exploded. How many volumes of hydrochloric acid gas will be produced?

The Imagination.—(35) Filthy water of the gutter, warmed by the sun's rays, escapes from a foul environment, and, condensing, sparkles like diamonds on the petal of the violet. Use this as basis for an allegory in life.

These questions do not by any means represent all the possible divisions of mental action, and I have purposely avoided those of a very technical nature, most of which, however, would fall under the heads given; but they will serve to indicate what opportunities there are to construct examination papers that shall test a student's knowledge and the working of his mind. It may be urged against the questions I have given

that several of them might fall as well under one head as another, or that a few more elaborate questions could be made out and each question marked under the several heads. My experience, however, has not been that the real ends are best attained in this way. The question that is distinguished by its definite nature and object gets a clearer answer and gives a more satisfactory insight into the student's mental equipment and action than a long or complicated one. If, after teaching a student a subject for a certain time, an examination shows that he can bring forth nothing more than that which has been put into him, it may be inferred either that the teacher is incompetent, or that the student is intellectually deficient; assuming, of course, that the system in the particular institution permits the teacher to do his best, does not assign him more pupils than one man can teach, and requires the student to do the work assigned to him. In such case I think that the fault usually lies with the teacher. Still I admit that there are institutions in which educational work of a high pedagogical order is impossible, and mind development, as distinguished from mind cramming, is out of the question. In such a case students are produced who are saturated with knowledge, but who are incapable of utilizing it. Like water-logged vessels they roll about aimlessly, and are unable even to keep out of the way of craft which are taking the fullest advantage of wind and tide. In such an institution the earnest teacher, when he fails, deserves sympathy more than blame.

The results of examinations, conducted on some plan like the one I have attempted to describe, are very interesting. Such examination papers are far more difficult to write than the calls for mere memorization that are so frequently made on the student, and which a hasty cram will enable a fairly bright candidate to pass. The answers are

* Compare London University Matriculation Examinations, Stoker and Hooper, p. 31. Q. 6.

† Colorless.

‡ Chlorine cannot be collected over mercury.

§ Once.

more difficult to rate; and often an attempt to mark them according to the usual rules is unsatisfactory. It is quite easy to assign a mark to the amount that a student knows, or even to discriminate as to the quality of his knowledge. To assign a figure to his ability to apply this knowledge, to originate, to create, to act under its instigation, is more difficult; yet it can be done with a fair degree of success.

It must always be borne in mind that a man's value in this life does not depend merely on what he knows, but upon what he can do. *Ceteris paribus*, the more he knows, the more he should be able to do; for so much the greater should be the incentive, if the knowledge imparted to him acts on him as it should. Until technical education was introduced, this fact was not well understood, and it is still far from appreciated in many schools.

For instance: A shows in his paper an encyclopedic knowledge. In his answer to Q. 11 he recites with great precision the properties of silica and iodine. But he fails to answer Q. 30, which calls for a conclusion dependent upon this knowledge. He is like a recruit who has been given a gun, but has not been taught how to fire it off. Such a student demands the teacher's attention at once. His mental inaction is usually the result of poor teaching.

It may not be amiss for me to say parenthetically here that teaching is the most difficult of all professions. It is not usually regarded so, but I believe that it is. Much of what is called teaching is nothing more than a kind of pumping. Knowledge is forced in through the most convenient intellectual orifice, a great deal being lost *in transitu*, and not a little leaking out afterwards. The engorged recipient is like a boiler whose feed pump is too big for it and will not cease pumping, but fills the boiler entirely full of water and leaves no space for steam; whereon the engine slows down

and stops, or throbs soggily with its cylinder filled with lukewarm water instead of hot expansive steam.

Again, a student may fail in his attempts to state anything correctly or exactly; but he fills pages with attempts to apply his knowledge, suggesting all sorts of ideas and applications. Most of them may be impossible, some even ridiculous. But no matter, let the teacher take hold of this boy at once, for the mind of an Edison, a Siemens or an Ericsson may be seeking nourishment and development. Happy is the teacher who can discern what mean the instinctive strugglings of the embryonic master mind, and who can liberate it from the thralldom of routine—who can guide its first weak attempts to walk and climb, until it becomes hardy and venturesome, and fearlessly scales cliffs heretofore inaccessible; and so clambering by hitherto unknown ways to the peak discovers new fields for human activity, and cuts a wide path by which thousands may enter and take possession.

What man gets closer to the Creator than the teacher, who can discern and understand His idea as shown in the youth and who clears away the obstacles in the way of its development, nourishes it until it is strong and independent, and itself becomes creative? Verily such a teacher has his reward.

Examination papers constructed on the basis I have suggested, viz.: to test not only the knowledge possessed by the student, but also the working of his mind upon the particular subject, will show more clearly the nature and condition of a mind than the daily recitation, because the case is more capable of systematic study and can be made to cover larger fields of mental activity. While I do not intend to suggest that such examinations should replace the regular recitation, I believe that they should be held frequently, and should serve a far wider purpose than that of merely

noting the quantity of knowledge absorbed by the mind. Such an examination is not a mere matter of testing and registering—it is a creative exercise of the mind.

PETER T. AUSTEN.

BROOKLYN POLYTECHNIC INSTITUTE.

THE 'NEW RACE' IN EGYPTIAN HISTORY.

DURING the session of the International Geographical Congress, Professor Flinders Petrie invited a number of the members to visit the extraordinary collection of Egyptian antiquities exhibited at the University College, the results of his excavations between Ballas and Nagada in the early months of 1895. They may well be called 'extraordinary,' as they introduce an entirely new element into the history of ancient Egypt, proving the presence on the Nile 'of a fresh and hitherto unsuspected race, who had nothing of the Egyptian civilization,' to quote Professor Petrie's words. Not that they were uncivilized. Far from it. Their culture was in some respects superior to that of the Egyptians of their age; but it was wholly independent of it, developed in another center, under an entirely different inspiration and technique, proving it the product of another ethnic group.

These intruders overthrew the great civilization of Egypt at the close of the VIth dynasty, and were in turn overthrown by the rise of the XIth dynasty at Thebes. In the current chronology this would place them from 3300 to 2800 B. C. They completely expelled or destroyed the former inhabitants for more than a hundred miles along the Nile Valley, in the district situate between Gebelen and Abydos. How thoroughly they extirpated their predecessors in this region may be judged by the fact that, in opening over two thousand of their graves and examining several of their town sites, not a single Egyptian object was found. Nor did they care to learn any Egyptian

art; for though they worked extensively and skilfully in clay, all their vessels are made by hand, and they refused to adopt the potter's wheel, which was then and long before familiar to the Egyptians. They brought with them a culture belonging to the highest neolithic type. I have never seen in any other collection, flint implements of equal finish or so graceful in outline. Beautifully polished beads and small ornaments of cornelian, amethyst, turquoise, garnet and other hard stones were found in abundance. Stone vases were shown in great variety and of graceful outlines.

The decorative designs are often elaborate, some in conventional lines, spirals and network, some representing boats, birds, trees and human beings. Animal designs in relief are portrayed with artistic consciousness.

Of metals, copper was the only one in frequent use. Adzes, needles, harpoons and daggers were manufactured from it.

Their mode of interment was altogether unknown to the Egyptians. The bodies were buried in the gravel, not in rock tombs. The graves were square pits, and the corpse was laid in a contracted position with the head to the south and the face to the west. The custom of incineration did not prevail; but there are signs of funereal human sacrifices, and apparently of cannibalism.

It is not likely that they shared the Egyptian's skill in architecture. Two of their towns which were examined showed remains of structures of mud brick of small size.

What were the ethnic relations of these mysterious invaders, this 'new race,' as Professor Petrie called them?

In the interesting address which he made to us on the occasion of our visit, he expressed himself cautiously but with a positive conviction. From numerous analogies

of culture, of cranial forms, of geographic position, of historic references, he had been led to the conviction that they belonged to the Berber or Libyan groups, that vast ethnic stock which occupied the whole of north Africa, west of the Nile Valley, above the Soudan. His arguments seemed to myself and others quite sufficient, at least in the present stage of the investigation.

What is especially noteworthy is the fact that civilization was highest on their arrival. Later it degenerated, and finally became absorbed in the Egyptian. Therefore, if Professor Petrie is right in his identification, we must credit to the Numidian-Libyan tribes of the fourth millennium B. C. a culture of native growth higher in many respects (though inferior in others) to that of the Egyptians who were their contemporaries.

Of the many and brilliant discoveries we owe to the indefatigable zeal of Professor Petrie, this last, of which I give this cursory account, is perhaps the most important for the history and ethnography of the Nile Valley and northern Africa.

D. G. BRINTON.

LONDON, Aug. 3.

CURRENT NOTES ON PHYSIOGRAPHY (XIV).

FOUREAU'S EXPEDITION INTO THE SAHARA.

FOR the third time, Foureau has been repulsed by the Touaregs in his attempt to cross the desert and reach the inland district of Air. The nomads resent the intrusion of European explorers, and do not wish to hear of commerce or trans-Saharan railways. Although not an expert in geographical description, Foureau's account of his unfortunate expedition gives many interesting sketches of the *hammada*, or rugged sandstone uplands, too stony for camels to cross; the *erg*, or sandy areas of the lower lands, with chains of dunes trending N. E. -S. W., as if controlled by the trade winds; the numerous *wadies*, or stream courses,

universally adopted as routes of travel, although caravans are here sometimes overwhelmed by floods from which there is no escape where the walls are steep. Gently sloping plateaus (*hammada*), dissected by long consequent valleys to the north and broken by short and steep obsequent streams on their south-facing escarpments, are characteristic features of the regions south of Wargla, in latitude 27°. Much of the surface near the wadies is minutely dissected, and would be called 'bad lands' by our Western explorers. The barrenness of the stony plateaus is complete; but along the wadies there are acacias and scattered herbage on which horses and sheep find a scanty pasture. A little wheat is raised on the flood plains. Swarms of grasshoppers sometimes consume the vegetation. The people are excessively poor, and all are great beggars, clamoring for gifts. In November, 1893, minima of -6° C. were recorded several times; sleeping without a tent, the explorer's blanket was covered with frost nearly every morning. Although suffering from cold, Foureau found, on the other hand, plenty of water in pools along the wadies, for in the five winter months of 1893-'94 there was rain on twenty-two days. Snow was seen on the plateaus. On several mornings there was dense fog. The Touaregs thought the cold spell was brought by the explorers. Mouflons were seen on the *hammadas*, and antelopes were common on the *erg* districts (Bull. Soc. géogr., Paris, XVI., 1895, 10-74).

LACCOLITIC MOUNTAIN GROUPS.

THE fourteenth annual report of the United States Geological Survey contains an interesting chapter on the laccolitic mountain groups of Colorado, Utah and Arizona, by Whitman Cross. It serves as an extension of the report on the Henry mountains by Gilbert of some years ago. While the chief value of this chapter is in

its discussion of structural and petrographical problems, it is of use to the physiographer also in giving excellent description and illustration of typical examples belonging to this peculiar member of the volcanic group of forms. It may thus serve as a corrective to the undue share of attention ordinarily allowed to the superficial loose-textured and short-lived volcanic cone. It serves also to enforce the idea that the surface of the land as we see it is often deeply carved in land of earlier times; truly a primitive geological conception, but one which geographers have been slow to recognize and utilize.

THE RUN-OFF OF RIVERS.

THE same report of the survey contains a chapter by F. H. Newell on the results of stream measurements, in which an important relation is indicated between rainfall and topography, on the one hand, and 'run-off,' on the other. For example, where the mean annual rainfall on mountainous regions is 40 inches, the run-off approaches 30 inches; where the rainfall is 25 inches, the run-off is 15; where the rainfall is 12, the run-off is only 5. On more open country, where the mean annual rainfall is 50 inches, a run-off of 25 inches may be expected; where the rainfall is 30 inches, the run-off is about 8 inches; while where the rainfall is 20 inches, only about 3 inches gets into the streams. In both mountainous and open country, the percentage of run-off rapidly decreases as the rainfall lessens. One notable exception to this rule is noted. In regions of small rainfall, under twelve inches, the rain usually falls at long intervals, but then at an excessive rate, often as 'cloud bursts.' In such cases the water has little time to penetrate the ground, and the run-off is exceptionally large. An interesting map of the mean annual run-off of our country accompanies this essay.

W. M. DAVIS.

HARVARD UNIVERSITY.

SCIENTIFIC NOTES AND NEWS.

THE BRITISH MEDICAL ASSOCIATION.

THE sixty-third annual meeting of the Association convened in London on July 30th, with an attendance of nearly 3000 members. The growth of the Association in recent years has been remarkable. When it last met in London (1873) the membership was 1500, whereas now it is the strongest medical society of the world, having 15,669 members and property of great value. The address of the president, Sir J. Russell Reynolds, was entitled 'The power of life in life,' and discussed in part the use of 'living things' in the conservation of health and the prevention or cure of disease. The address also reviewed the progress of medicine since the preceding London meeting and the relations of professional life to certain aspects of art and religion. The Association met in fifteen sections, before each of which many papers were presented, followed by discussions of much interest, not only to members of the medical profession, but also to all interested in the progress of science. The Association occupies somewhat the position of a professional trades union, and with its great membership and means and its organ, *The British Medical Journal*, is able to influence, not only the etiquette and practice of the profession, but also legislation. The reports of committees, such as that on Parliamentary bills, and the discussions that followed, were consequently of great practical importance.

SECTION C, CHEMISTRY, OF THE A. A. A. S.

THE committee appointed by the Council to prepare a programme for the meetings announce that the Committee after careful consideration believe that added interest may be given to the meetings by providing, in addition to the original papers that may be offered, a series of discussions of subjects of current interest to chemists, in

which all who may be present may take part. In order that a systematic course may be followed in these discussions, each general division of chemical work arranged for this meeting will be introduced by a member of the section, who will be followed in turn by some other members who may have anything to offer. These discussions will be open to all members of this Section, but it is requested that those who may have something to offer will advise the Chairman of the Committee of the fact and submit to him as early as possible a brief abstract or syllabus of the material. The object of this is to enable the Committee to make a systematic arrangement of the work to be done. The several sessions will be devoted respectively to physical, general inorganic, general organic, analytic, didactic, biologic, hygienic, agricultural and technical chemistry. The address of the vice-president, Dr. William McMurtrie, is on 'The Relations of the Industries to the Advance of Chemical Science.'

THE BOTANICAL SOCIETY OF AMERICA.

The Botanical Society of America was formally organized last summer at Brooklyn. The first annual meeting will be held at Springfield, Mass., Tuesday and Wednesday, August 27th and 28th, immediately preceding the meeting of the A. A. A. S. The sessions of the Society will be held in the High School building, room 6, first floor, beginning at 3 P. M., Tuesday. The Council will meet at the Hotel Worthy at 2 P. M. of the same day, for the purpose of arranging the program and for such other business as may come before it.

C. R. BARNES, *Sec'y.*

VITAL STATISTICS OF NEW ENGLAND.

A SUMMARY of the vital statistics of the New England States for the year 1892 has been compiled under the direction of the

secretaries of the State Boards of Health and published by Damrell & Upham, Boston. It appears that the birth rate of New England, 24.9 per thousand of the population, was less than that of any European country excepting France and Ireland. The death rate (19.9) was less than that of Italy, Hungary, Austria, Germany, France, Holland and Belgium, but greater than that of the British Islands, the Scandinavian countries and Switzerland. The marriage rate (18.5) was higher than that of any other country. The illegitimate births were only 13.4 per thousand living births, whereas in Europe they vary from 25 in Ireland to 143 in Austria. The total population of New England (4,700,745) is almost equally divided between the urban population contained in cities having a population larger than 10,000 and the rural population. The marriage, birth and death rates in the two groups were as follows:

| | Marriage. | Birth. | Death. |
|-------------------|-----------|--------|--------|
| Urban Group | 20.66 | 29.68 | 21.01 |
| Rural Group | 16.42 | 20.00 | 18.72 |

GENERAL.

At the *Versammlung deutscher Naturforscher und Aerzte*, which will be held in Lübeck, under the presidency of Professor J. Wislicenus, from the 16th to the 21st of September, the following lectures will be given: On Some Problems of the Physiology of Reproduction, by Professor G. Klebs; Serum Therapeutics, by Professor Behring; Surgical Operations on the Brain, by Professor Riedel; Atomic Problems, by Professor Victor Meyer; Neo-Vitalism, by Professor von Rindfleisch; The Origin of the East Sea, by Professor R. Credner; The Overthrow of Scientific Materialism, by Professor W. Ostwald.

ACCORDING to the *Naturwissenschaftliche Rundschau*, the 'Göttingen Gesellschaft der Wissenschaften' offers a prize of 500 marks, to be awarded February 1, 1897, for an anatomical research and description of the cavities of the body of the new-born child and their contents compared with those of the adult. The Academy of Sciences of Cracow proposes, as subject for the Copernicus prize (1000 and 5000 fl.), theories concerning the physical condition of the globe. The essays must be received before the end of December, 1898, and must be written in the Polish language.

The Annual Congress of the British Institute of Public Health was held at Hull, on August 8th to 13th.

MR. ADOLPH SUTRO, Mayor of San Francisco, has offered to the Regents of the University of California thirteen acres of land on which to erect buildings for the affiliated colleges of the University. In addition he offers to deed to the trustees of the city thirteen acres adjoining as a site for the Sutro Library. The collection of books is said to contain 200,000 volumes, and the total value of gifts to be \$1,500,000.

MR. GRANT ALLEN has written *The Story of the Plants* for Appleton's Library of Useful Stories.

THE Japanese government has made an appropriation for the laboratory of Dr. Kitasato, in which researches of great importance are now in progress on the cause of leprosy.

At a conference on the deaf and dumb held recently at Exeter Hall, London, a constitution for a new national association was adopted. Among other addresses was one by Mr. J. N. Bannerji on the position of the 200,000 deaf mutes in India, the education of whom is unassisted by the government. The following resolutions were passed: "That it is desirable that facilities should be given by which pupils of our in-

stitutions who show exceptional ability should have the advantage of a more extended education than it is now possible to give them." "That this conference considers it desirable that the governing bodies of institutions should at once petition the government to reduce the proportion of one-third, to be provided out of sources other than rates of moneys provided by Parliament, to the proportion of one-fifth." "That the committee of the National Association of Teachers of the Deaf be requested to draft at the earliest possible opportunity a scheme of education for children of school age as a suggestion to the Education Department."

THE 100th anniversary of the foundation of the Institute of France will be celebrated an October 23d, 24th and 25th with appropriate ceremonies.

THE Chemical Industry Society, an English society devoted to the study and practise of applied chemistry, with a membership of 2892, held its annual meeting at Leeds during the first week in August.

THE 'Berliner Akademie der Wissenschaften' has recently appropriated over \$5000 for the promotion of scientific work and research. Among others we may mention an appropriation of 2000 Mk. to Professor Fuchs, of Berlin, to be devoted to the continuation of the publication of Dirichlet's works; 2000 Mk. to Professor Weierstrass, of Berlin, for the publication of his collected works; 1500 Mk. to Professor Gerhardt for the publication of the Mathematical correspondence of Leibnitz, and 2000 Mk. to Dr. Schaumsland for researches on the Fauna of the Pacific islands.

THE Steward Prize of the British Medical Association for 1895, consisting of an illuminated address and a cheque for £50, was awarded to Brigade-Surgeon-Lieutenant-Colonel D. Douglas Cunningham, M. B., C. I. E., F. R. S., for his bacteriological

work in India, especially in the investigation of the bacillus of cholera.

THE chief article in the June number of the 'Quarterly Journal of Microscopical Science' is a study of Metamerism by Prof. T. H. Morgan, of Bryn Mawr College, in which he treats, on the basis of a large amount of original research, irregularities in the serial repetition of rings of annelids.

It has been shown in a report of the sub-committee of the Glasgow corporation that some samples of French peas examined contain fifteen grains of copper sulphate in the pound. The French government forbids the use of these peas in France, but allows them to be exported.

THE exhibition of the Department of Mines at the Cotton States and International Exposition will include four oil paintings 120 feet long, showing sections of the Appalachian range of mountains drawn on the scale of one foot to a mile. In these paintings every mineral and coal vein in in the Appalachian system will be shown. Sections from the different coal veins of the United States will be exhibited, some of these sections weighing seven tons and showing the whole vein. The exhibition is personally superintended by Dr. David T. Day, Chief of the Department of the Government Board of the Exposition.

GINN & Co. announce for publication this summer 'Lakes of North America,' by Professor Israel C. Russell. The origin of the lake basins and their place in topographic development, the movements of lake waters, the topography of lake shores, the relation of lakes to climatic environment, the life histories of fresh and of saline lakes, are some of the subjects discussed.

THE British Museum has recently published the accounts of the income and expenditure of the 'Special Trust Funds' for 1895. These are six in number, amounting to £24,177, of which the interest is £1,518.

This has been expended on salaries, the purchase of manuscripts and excavations in Cyprus. The number of visitors to the museum in 1894 was 578,977. An average of 670 daily visit the reading rooms for purposes of research and reference. 413,572 people were admitted to the collections of the Natural History department; of these 20,029 were students, chiefly in the department of zoölogy.

DURING the year a valuable collection of Hindu coins has been bequeathed to the museum by the late Sir Alexander Cunningham, and a large collection of Turkish books published in Constantinople during the reign of the present Sultan, by whom the volumes were sent. The museum has also acquired a portion of the collection of rare English books of the period of Elizabeth and James I., discovered in 1867, at Lamport Hall, the seat of Sir Charles Isham, where they appear to have been forgotten for two centuries.

By the will of Benjamin P. Cheney the sum of \$50,000 was left to various public institutions. The Massachusetts Institute of Technology receives \$10,000.

M. LUCIEN NAPOLEON BONAPARTE WYSE, a well-known engineer and explorer, died at Paris on August 12th, at the age of 51. He was a grandson of Lucien Bonaparte. He made extensive hydrographical and other scientific explorations, and in 1875 undertook the survey of the Panama isthmus. His "Rapport," 1876-78, on this survey was followed by the operations of M. de Lesseps on the Panama ship canal.

THE astronomer Andreas Löwald Pihl died in Christiania on July 1st, at the age of 73 years.

THE *Lancet* announces the deaths of Dr. S. Moos, professor of otology in Heidelberg; Dr. Kiener, professor of pathological anatomy in Montpellier, and Dr. Albert Nagel, professor of ophthalmology in Tübingen.

DR. ADOLF GERSTÄCKER, professor of zoölogy in the University of Greifswald, died on July 20th, at the age of 67 years.

DR. GUSTAV VON GROFE, professor of mathematics in the University of Dorpat, died recently at the age of 47 years.

MR. JOSEPH THOMPSON, one of the most distinguished and successful of modern African explorers, died on August 7th, at the age of 37.

UNIVERSITY AND EDUCATIONAL NEWS.

FEW realize the great work done at the University of Kansas along scientific lines. To-day, as happens every summer, several expeditions are in the field collecting for the enrichment of the university museums and laboratories. Professor S. W. Williston is spending his second vacation in the Bad Lands of Wyoming. Last summer he returned to the University richly rewarded for his summer's work by valuable specimens which were described by him during the year in the *Kansas University Quarterly*. Also under his direction, but not personal supervision, a party has been at work in the cretaceous deposits of western Kansas and eastern Colorado. Professor E. Haworth has been constantly busy in directing the Geological Survey of the State; this work being done in connection with the State Irrigation Survey. Last summer Professor Haworth completed a stratigraphical survey of the southeastern portion of the State. L. L. Dyche, curator for the zoölogical museums, is with the Peary Relief Expedition as chief naturalist. Professor Dyche hopes to secure many valuable specimens of Arctic mammals. Last season Professor Dyche was with the party on board the ill-fated *Miranda*. He had secured a large amount of material, all of which was lost when the vessel went down. Another expedition which goes out each summer is that from the Department of Entomology. This season collections for this department are

being made in northern Wyoming. Last year the summer was spent in New Mexico. But it is not alone in natural history that advances are being made. Along every other line work is being done. The physics and electrical engineering department has taken possession of the new building just completed which is to be devoted to the study of electricity. It is true that rare advantages are given the Kansas students of science in natural proximity to the great collecting regions of the west. But these rare advantages might have been allowed to remain undeveloped had not early in the history of Kansas a teacher been found who possessed in the highest degree the rare quality of being not only an enthusiast himself, but also a teacher capable of arousing enthusiasm in others. This teacher was Francis H. Snow, first professor of natural history, then professor of botany and entomology, and now Chancellor of the University. To him Kansas owes more than to any one man for the upbuilding of her great University. He laid the foundation for the great entomological collections now only second in size and value to those of Harvard; for the famous Kansas collection of mounted mammals; for the geological and paleontological museums, and for the excellent herbarium. But it is as Chancellor of the University that perhaps his most noticeable work has been done. Since 1890, when he was placed in the president's chair, the institution has doubled in size of equipment, number of students and power in the State. The standard of scholarship has been raised, and the University has been placed in the front rank of State Universities. X.

The Botanical Gazette states that on account of serious financial difficulties and a distrust of the progressive and enlightened educational policy of President John, the trustees of De Pauw University at Greencastle, Indiana, have forced the resignation of the president and set about a return to

the old paths. The department of biology having been founded by Dr. John was among the first to suffer. It was summarily abolished, the announcement being made without previous warning only the day before commencement. From a professor of zoölogy and one of botany at the beginning of the last college year, the instructional force is reduced to a single tutor, who is expected to give instruction in the elements of both sciences.

THE Board of Trinity College, Dublin, while declining to grant permission to women to attend lectures and examinations at the College, have offered, on certain conditions, to conduct examinations for special certificates.

THE Regents of the State University have voted to confer the university degree, M. D., only after one year's post-graduate study subsequent to receiving the degree of bachelor or doctor of medicine from some registered medical school, and only on candidates who have spent not less than four years' total study in accredited medical schools.—*Medical Record*.

PROF. J. W. JUDD has been appointed successor of Huxley as Dean of the Royal College of Science, South Kensington.

THE chair of surgery in the University of Breslau, vacant through the death of Prof. Trendlenburg, which was declined by Prof. Mikulicz, has now been offered Dr. Schede, of Eppendorf General Hospital, Hamburg.

DR. RUDOLF METZNER, of Freiburg, has been called to the chair of physiology in the University of Basel, in the place of Professor Miescher, who has retired.

DR. EMIL YUNG has been made professor of zoölogy and comparative anatomy in the University of Genf as successor to Karl Vogt.

DR. HANS PECHMANN has received a call to a professorship of chemistry in the University of Tübingen.

CORRESPONDENCE.

THE NEW BIBLIOGRAPHICAL BUREAU FOR ZOOLOGY.

ON January 1st, 1895, there will be established in Zurich, Switzerland, an International Bibliographical Bureau for Zoölogy and comparative Anatomy. This Bureau is being organized on the broadest foundations and will be strictly international in character. There are already a number of committees in the more important countries of the world, and it is to be hoped that the organization will soon be entirely complete. In this country there is a committee nominated by the 'Society of Naturalists.' In France the organization is quite complete, and may serve as a model of what we still need in this country. In the first place there is an influential central committee in Paris.* In connection with this body is a corps, 'Associate Members.' The function of the 'Membres Associés' is to exercise direct local influence in such emergencies as require it. For example, it is proposed to issue an appeal to all publishing societies, asking them to send in to the central Bureau their publications for the purpose of recording the zoölogical observations which they contain. From the very outset of our undertaking it became evident that scientific societies would in general be glad to respond to such an appeal, but that there were considerable difficulties in the way of relying unconditionally upon this coöperation. A preliminary canvass was undertaken among the leading Paris societies, which showed conclusively that both learned societies and publishing firms were most willing to coöperate, but that they would have to have the matter properly brought to their notice by persons devoted to the movement; a mere general appeal might easily go unnoticed, and thus important works never reach the Bureau.

* See the 'Rapport de M. Bouvier, Mem. Soc. Zool. de France,' 1895, 1er fasc.

The 'Membres Associés' undertake to look after this matter and see that every publication of their district is brought to the knowledge of the Bureau. The 'Associés' are 21 in number, and have already promised to do all in their power to accomplish their mission.

In addition to the 'Associés,' there is a body of 'Correspondants' whose duty is to record such publications as are inaccessible in any Swiss or Leipzig library. The 'Correspondants' are few in number and are all persons able to give considerable time to the work. A number of competent persons have kindly offered to do both classes of work in this country, and we can at least assume that the same generosity will be shown by publishing societies and publishers.

It must be remembered that it is not proposed to depend wholly upon these agencies for obtaining the material on which the work of the Bureau will be based; but that this organization is to supplement the more ordinary means of consulting the literature, *i. e.*, use of large libraries. Not only will the Bureau have access to works in the Swiss and Leipzig libraries; it will also have at its disposition the library of the Zoological Station of Naples. This arrangement is due to the generous coöperation of Geheimrath Dohrn, who, in addition to making an annual appropriation towards the support of the Bureau, has offered to have sent through the Bureau those works of which we may stand in need.

In order to treat adequately the Bohemian, Hungarian, Polish and Russian publications, special 'Sub-bureaux' are being organized. In Russia this is being provided by the Russian National Committee and by Professor Mitrophanow, who has shown remarkable activity in this connection. In Galicia similar steps have been taken by Professors Hoyer, Sr. and Jr., and a Sub-bureau will be organized at Krakow.

Turning now to the system of recording,

let it be noted, at the outset, that the staff of the Bureau will consist of zoölogists rather than of librarians. This fact permits it to undertake a task of immense value to the investigator, *viz.*: that of basing the subject index upon the text of the memoirs, instead of upon the mere title. I do not need to dwell upon the value of this feature. The insufficiency of the title for such purposes is familiar to every worker. In a previous note, I have already given a case from my own personal experience, in which the titles were absolutely valueless to the bibliographer of the question I then had in hand. An idea of the defectiveness of our existing bibliographical means can readily be obtained by anyone who will take the pains to compare the bibliographies found at the end of a number of special memoirs with the lists given under the corresponding headings of the best of our present catalogues. The classification given by the Bureau will then be based upon the *text* and will use the individual observations—the paragraph—as a unit, and not the paper as a whole. Furthermore any incidental observations, though wholly different from anything in the title, would be brought out by the Bureau.

The publications of the Bureau will consist in two principal editions: (1) a fortnightly bulletin and (2) a card catalogue. The morphological titles will also be reprinted annually by the 'Zoologischer Jahresbericht,' and indexed according to authors. It would be desirable if some similar arrangement could be made for systematic zoölogy; but this has not been provided for. It was our hope that the 'Zoölogical Record' might be transformed, so as to form together with the 'Zoologischer Jahresbericht' a complete annual record for zoölogy, but it seems unlikely that its directors could accept such an arrangement. It must not be forgotten by those who have urged this upon us, that the Zoölogical Record is pub-

lished with considerable pecuniary loss, and that our Bureau is unable to offer any adequate guarantee that the loss would not be just as great, unless the guarantee of a continental publisher would suffice.

The Bulletin will be divided into a series of chapters, including 1, a general part, and 2, a division into systematic groups. Under each heading will be placed not merely such works as deal exclusively with the matter indicated, but also—as cross references—any papers containing incidental observations in regard to it.

The Cards will be issued simultaneously with the Bulletin and will be of the standard Library Bureau size. They will be essentially Author's Cards, but will also bear classificatory symbols of such nature that they can readily be placed in a subject index by persons unfamiliar with zoölogy. Three sets of symbols will be used, each indicating a distinct system of classification—systematic, morphological and faunistic—and all based upon a study of the text.

MAURER, F.

XIII., 7.

1894 b. Die ventrale Rumpfmuskulatur der anuren Amphibien. *Morph. Jahrb.*, Bd. 22, p. 225-262, Taf. 6, 7.

[Entwicklung—*Rana*; Anatomie—*Dactylethra*, *Ceratophrys*, *Bombinator*; Vergleich mit Urodelen.]

It is proposed to receive eventually subscriptions to the cards relating to *limited topics*. A student of a special question could then be informed at once of the appearance of each publication touching his particular field, and thus be saved much of the mechanical labor of looking through the journals for the papers which interest him. For the present, however, larger divisions only of the catalogue can be so offered.

I have already spoken of the generosity of Geheimrath Dohrn; the further support which the Bureau will receive consists in

part in the establishment of sub-bureaus at the expense of the nations concerned, *i. e.*,—Russia, Poland—in part in the voting of money grants towards the maintenance of the central Bureau: *e. g.*, the Swiss Federal Board of Education, the cantonal and town Boards of Zürich, a subscription under the 'Société Zoologique de France.' In this country a subscription of \$250 in addition to what has already been secured is all that is asked for. It does not seem too much to expect that this sum can be raised in the country as a whole as soon as the learned societies meet again in the fall:

In conclusion, let me say a few words in regard to the relations of our undertaking to that of the Royal Society. The organization of the Zoölogical Bureau was already well under way and several committees had been appointed when the circular of the Royal Society came to hand. On receipt of this circular we at once made inquiry of the Secretary of the Society, Professor Foster, in regard to the probable attitude of the Royal Society towards our undertaking, and were assured that the Royal Society would certainly prefer to absorb, or make one with it, all existing enterprises, rather than to try to rival them with a new one. A more definite answer was at that time impossible, nor can it be given at present. It was, however, all that we could desire, for this was precisely the great difficulty of our task, *viz.*: that it involved too great personal sacrifices for it to be possible to count with certainty upon its being given us through long periods of time. The Bureau is therefore being organized provisionally for the period of 5 years, so that the work can then be continued under the auspices of the Royal Society, provided the Society succeeds in realizing its project. On the other hand, if the larger plan fails, then the Bureau must live on its own resources. This is surely a wiser course than to abandon the undertaking and make useless the

sacrifices already made; in any case the literature for the period from 1896 to 1900 will have been well indexed and an important experiment in view of the Royal Society's undertaking will have been tried.

I should like finally to remind authors and publishers that they can greatly aid in this work by preparing short *résumés* of their publications as recommended in these columns by Professor Bowditch.

HERBERT HAVILAND FIELD.

GREAT NECK, L. I., NEW YORK.*

SCIENTIFIC LITERATURE.

Le pétrole, l'asphalte et le bitume, au point de vue géologique. PAR A. JACCARD, professeur de géologie à l'académie de Neuchâtel. Ancienne librairie Germer Baillière et cie. Paris. 1895.

This work forms one of the volumes of the Bibliothèque Scientifique Internationale and has been published since the author's death, on the 5th of last January.

The task of reviewing the work of one no longer living imposes upon the reviewer great care that no injustice shall be done the author, either as regards his intention or accomplishment. A very careful perusal of the work has shown that the author was a very close observer of nature, and a man of very positive convictions within the range of his own observations, yet in his final conclusions not too confident of his own infallibility, although at times, along the line of argument that he maintains throughout the work, his language very closely approaches upon dogmatism. He devoted his life to the study of the geology of the Jura, and that portion of France and Switzerland which includes the celebrated deposits of bituminous limestone and sandstone lying in the upper valley of the Rhone, from Neuchâtel to Pyrimont and beyond. In this work he has included, not

only the results of his own observations, but those of many other writers from the earliest mention made in scientific literature to the present time. I do not question that in respect to this particular department of the general literature of bituminous substances, or, more properly speaking, of bitumen, that this work is without a rival the most complete that has been devoted to the scientific discussion of this subject.

I think it is to be regretted that the author attempted a more ambitious work, and sought to reach general conclusions that, beyond the horizon of his own observations, were based upon the work of others made at various dates and under various conditions, which M. Jaccard appears to have accepted without much discrimination. He further allowed himself to be confined exclusively to works written in the French language which, embracing, as they do, many of the most valuable original memoirs extant, would at the same time exclude all access to the original works of American, English and German writers on the subject. As an illustration he quotes at this date (1895) the conclusions reached by M. Daubré in his 'Rapport du jury de l'exposition internationale de Paris, 1867,' in relation to the petroleum of North America. This paucity of information written in the French language, and injudicious use of French authors who have discussed the subject second hand, renders the work of very little value so far as it relates to American bitumen.

Again, he devotes a considerable portion of the work to the discussion of the 'Origin of Bitumen,' a subject that cannot be discussed from the 'point of view' of geology alone, as it involves a knowledge of both the chemistry and technology of bituminous substances. The apparent lack of knowledge of the details of the chemistry and technology of bitumens has led to many misstatements and invalid conclu-

* Address after September 3d, care of Brown, Shipley & Co., London, E. C.

sions throughout the work. To cite these instances in detail would require too much space, but they will not fail to arrest the attention of those familiar with the subject. It is no doubt to the same fundamental cause that the work owes its grave defects in classification, a defect that appears even in the title. Bitumen is the generic term that includes all forms of petroleum and asphalt. Moreover, no distinction is made between the peculiar use made by French authors of the word *asphalte* as applied to the asphaltic limestones and sandstones of eastern France and Switzerland and the use of the word to designate the solid form of bitumen, in which latter use he has made it the equivalent of 'asphalt' in English. The words naphtha and petroleum, and petrole and maltha, are also used interchangeably to some extent in some places and with different meanings in others, so that throughout the work the use of these words is not clear. This confusion arises from a disregard of details that belong to chemistry rather than to geology.

As a whole, the work possesses great merits and grave defects; especially is the latter statement true in relation to American bitumen. The work should be read with careful discrimination, which is much to be regretted, as it will doubtless be widely read in Europe, where its merits will be much more apparent than its defects.

S. F. PECKHAM.

The Glacial Nightmare and the Flood. By SIR HENRY HOWARTH, K. C. I. E., M. P., F. G. S., etc. 2 vols. Pp. 11-920. Sampson, Low, Marston & Co.

This volume is a manual of the facts and changing opinions gathered and expressed by the students of the superficial features of Europe and America from the earliest days of observation, and brings into prominence the names of many excellent men formerly overlooked or forgotten. The work is a fair

history of the rise and decay of the theory of floods, of the universality and restriction of iceberg action, of the origin and culmination of the glacial theory. Thus far the author's views are only seen in the title. On the subject of the unity of the glacial period, the evidence is stated with the writer's judgment favoring one general period of cold. The astronomical theory of the cause of the Ice Age is shown to be unsustained by the evidence. The cause of glacial motion and the mechanical effects of the glaciers are discussed in a masterly manner, with conclusions very acceptable to most of us. The use of the doctrine of an ice cap and its subsequent restriction to continental areas is explained. But now the work is directed against extreme views, which have prevailed or are still dominant, on the ground of want of evidence. In the latter part of the work the writer ceases to be the judicial historian and becomes the philosopher, and explains some phenomena of the drift, carefully analyzed, by an appeal to 'waves of translation,' a modification of the doctrine of catastrophies in contra-distinction to the ideas of extreme uniformity which often need modification. The work is invaluable to the American student on account of giving him access to many of the fathers of superficial geology, whose works are not ordinarily accessible. These works also show how much more had been done by the early observers than is credited to them by most modern writers, partly on account of facts becoming public property in course of time, and partly on account of the impossibility of doing justice to so many men at all times. Yet these men were the intellectual ancestors in the field of surface geology. Another lesson is taught that conclusions of many of the most distinguished writers have not withstood deeper research, and have been replaced by the views of others who in turn will pass behind the curtains of time. Yet the science was originated and devel-

oped by these early geniuses, who should still be honored. As a manual the work should be in the hands of every student of superficial geology, and must form one of his most valuable works of reference. In a great manner the conclusion of the author will be most acceptable. On other points, differences of opinion will prevail here as in the works of all other philosophic writers. The title of the book is its sensational feature, and might awaken more opposition than its general judicial character would give rise to.

J. W. SPENCER.

The Etiology of Osseous Deformities of the Head, Face, Jaws and Teeth. By EUGENE S. TALBOT, M. D., D. D. S. Third Edition. Revised and enlarged, with 461 illustrations. Chicago, The W. T. Keener Company. Pp. 487.

Dr. Talbot's work is a most ambitious one, and this is perhaps its chief fault. It contains an enormous amount of facts and figures gathered from every source and touching upon every question from anthropology and crime to the useful art of taking care of the teeth. If the doctor could have condensed his book and given it a little more proportion and coherence it would appeal much more to the general and scientific reader. As it is, we find in it much original observation and a multitude of anatomical and anthropological facts which are interesting and should prove useful.

An excellent example of the author's work is shown in his chapter on developmental resources. Here he starts with the simple problem of the palatal arch in idiots and ends in a discussion of the general problem of osseous deformities as related to the different forms of degeneration. Dr. Talbot is manifestly a follower of Morel and Lombroso and adds many facts in support of the view that characteristic stigmata accompany the degenerative state. We must add again, however, that he fails to

take what we would consider a properly conservative view of the question, and, while he gives many valuable data regarding criminals, he does not, we think, consider sufficiently the anatomy of the normal man of the low social stratum from which most of his criminals come. Lombroso has himself abandoned anthropometrical measurements as affording much help in establishing a criminal type.

We must add, in conclusion, and in justice to Dr. Talbot, that we know of no American who has made so many personal observations and measurements on the defective classes, and he is entitled to great credit for his work.

CHARLES L. DANA.

DOUBLE REFRACTION IN WOOD.

Doppelbrechung electrischer Strahlen. K. MACK. Wied. Ann. 54, 1895, p. 342.

Bemerkung über die Abhandlung von Herrn Mack. W. VON BEZOLD. Ibid. 54, 1895, p. 752.

Doppelbrechung electrischer Strahlen. A. RIGLI. Ibid. 55, 1895, p. 389.

Mr. Mack's article describes an interesting series of experiments to demonstrate that plates of wood exhibit a double refraction of electric waves. The sender and receiver were so arranged, with spark gap and reflectors, that the waves were 50-60 cm. in length. The test for double refraction in light is the lightening up of the field when the substance is introduced between crossed Nicols; similarly, Mr. Mack tested for double refraction of electric waves by introducing plates of wood between crossed sender and receiver. The first plates were of fir-tree 0.5-1.0 sq. M. area and 2,3 cm. thick, and gave negative results. An octagonal plate of fir about 60 cm. in diameter and 20 cm. thick was afterward used, and showed a decided double refraction when its fibres were 45° to the sender and receiver, and also between parallel sender and receiver showed

greater absorption when its fibres were parallel than when they were perpendicular to the plane of the vibrations. That is, the wood is double refracting and transmits best when the plane of vibration is perpendicular to the direction of the fibres and absorbs most when they are parallel. In fact, to this absorption the author ascribes the reappearance of the sparks with the crossed sender and receiver, since the plates of wood were not thick enough to give a retardation of one ray behind the other equivalent to a half wave-length; in fact, the plates were only from $\frac{1}{8}$ to $\frac{1}{2}$ a wave-length thick. The phenomenon was observed with plates up to 35 cm. thick and of fir, oak and beech. Plates cut perpendicular to the fibre showed no double refraction as was anticipated. The author refers to the experiments of Starkl showing that the thermal conductivity of wood is different, parallel with and perpendicular to the fibre.

W. von Bezold calls attention to the experiments on thermal conductivity by Tyndall, which led him in 1871 to experiment upon the Lichtenberg figures formed upon wood. At that time von Bezold found that the Lichtenberg figures on plates of wood cut with the grain fibre were elliptical with the major axis at right angles to the fibre, while the ellipses obtained upon the same wood by Senarmont's method of testing thermal conductivity were much more elongated and in the direction of the fibre. The author was able to give to a hard rubber plate an anisotropic character by pasting parallel strips of tinfoil upon the back, whereupon it gave Lichtenberg figures similar to those on a piece of wood cut with the grain. He suggests experiments with a dielectric in which are imbedded rods of a conductor or a dielectric of different inductive capacity.

A. Righi points out that he had presented a paper before the Academy of Sciences at Bologna, which Mr. Mack evidently had not

seen, although it was read nearly six months before his article appeared. On that occasion Mr. Righi described experiments similar to those of Mack, wherein he obtained identical results, even identifying elliptical and circular polarization in wood.

In conclusion, I may state that I have recently examined thin films of wood between crossed Nicols, using sunlight, and found in all cases the behavior toward light the same as that described for electric waves, albeit, one sees that the double refraction is not shared equally by all the components of the wood.

WILLIAM HALLOCK.

Distribution of the Magnetic Declination in Alaska and Adjacent Waters for the Year 1895. Bull. No. 34, U. S. Coast and Geodetic Survey. 8°, 6 pp. and 1 chart.

The above is a brief abstract of a fuller report to be published later by C. A. Schott, Assistant. As the title indicates, the paper attempts to give the latest representation of the distribution of the magnetic declination for the region indicated. It hence replaces the earlier (1890) attempt and gives evidence of a decided improvement. On account of the wide extent of the region involved and the paucity and irregular distribution of the observations; the analytical method of representing the available declinations was adopted. The formula established gives a very satisfactory accord with the observations covering a territory from 47°.4 to 71°.3 N and from 122°.4 to 156°.5 W. of Gr. The largest discrepancy between the observed and computed declination is but 0°.9; the probable error of a single representation, $\pm 19'$.

On the chart the isogonics or lines of equal magnetic declination, as obtained with the aid of the formula, are given at intervals of one degree for the region covered by the above title.

L. A. BAUER.

SCIENCE

NEW SERIES.
VOL. II. NO. 35.

FRIDAY, AUGUST 30, 1895.

SINGLE COPIES, 15 CTS.
ANNUAL SUBSCRIPTION, \$5.00.

GUSTAV E. STECHERT'S Recent Importation of Scientific Books.

BECKERT, TH. and DR. ALBANO BRAND. Hüttenkunde. Mit 235 in den Text gedruckten Figuren. 765 Seiten. gr. 8°. Mk. 20.

BEHRENS, H. Anleitung zur mikrochemischen Analyse. Mit einem Vorwort von Prof. S. Hoogewerff in Delft. 224 Seiten mit 92 Figuren in Text. 8°. Mk. 6.

BIEDERMANN, W. Elektrophysiologie. 1^{te} Abtheilung. Mit 136 Abbildungen. 440 Seiten. 8°. Mk. 9.

BORCHEERS, DR. W. Elektro-Metallurgie. Die Gewinnung der Metalle unter Vermittlung des elektrischen Stromes. 2^{te} verm. v. völlig umgearb. Auflage. 1^{te} Abtheilung, mit 87 Abbildungen. 160 Seiten. gr. 8°. Mk. 6⁹⁰.

BUSCHAN, GEORG. Vorgeschichtliche Botanik der Cultur-u. Nutzpflanzen der alten Welt auf Grund prähistorischer Funde. 268 Seiten. 8°. Mk. 7⁹⁰.

DAMMER, DR. O. Handbuch der chemischen Technologie. Unter Mitwirkung von Direktor Th. Beckert, Dr. Bender, Dr. Benedikt, Dr. Börsenstein u. A. herausgegeben. 3^{ter} Band. Mit 235 in den Text gedruckten Figuren. gr. 8°. Mk. 20.

DELAGE, YVES. La structure du protoplasma et les théories sur l'hérédité et les grands problèmes de la biologie générale. 878 pages. gr. 8° cloth. frs 24⁰⁰.

DETMER, DR. W. Das pflanzenphysiologische Praktikum. Anleitung zu pflanzenphysiolog. Untersuchungen für Studierende u. Lehrer der Naturwissenschaften, sowie der Medicin, etc. 2^{te} völlig neubearbeitete Aufl. Mit 184 Abbildungen. 456 Seiten. 8°. Mk. 9.

FOREL, DR. AUGUST. Der Hypnotismus, seine psycho-physiologische medicinische, strafrechtliche Bedeutung und seine Handhabung. 3^{te} verb. Aufl. mit Adnotationen von Dr. O. Vogt. 223 Seiten. gr. 8°. Mk. 5.

FRANK, DR. A. B. Die Krankheiten der Pflanzen. Ein Handbuch für Land u. Forstwirthe, Botaniker, etc. Erster Band. Die durch anorgan. Einflüsse hervorgerufenen Krankheiten. Mit 34 Holzschnitten. 2^{te} Aufl. 344 Seiten. 8°. Mk. 6⁹⁰.

HIS, WILH. Die anatomische Nomenclatur. Nomina anatomica, Verzeichniss der von der anatomischen Gesellschaft auf ihrer 9. Versammlung in Basel angenommenen Namen. Mit 30 Abbildgn. im Text und 2 Tafeln. 180 Seiten. Mk. 7⁹⁰.

HOUDAILLE, F. Météorologie agricole. 204 pages cloth. fr. 3.

JAHREBUCH DER ELEKTROCHEMIE. Berichte über die Fortschritte des Jahres 1894. Im wissenschaftlichen Theile bearbeitet von Dr. W. Nerst. Im technischen Theile bearbeitet von Dr. W. Borchers. I^{er} Jahrgang. 274 Seiten. gr. 8°. Mk. 10.

JERUSALEM, WILH. Die Urtheilsfunction. Eine psychologische und erkenntniskritische Untersuchung. 269 Seiten. Mk. 6⁹⁰.

LOEWY, DR. A. Untersuchungen über die Respiration and Circulation bei Aenderung des Druckes und des Sauerstoffgehaltes der Luft. Mit 5 Curventafeln im Text. 155 Seiten. gr. 8°. Mk. 4.

MEYER, DR. ARTH. Untersuchungen über die Stärkekörner der höheren Pflanzen. Mit 9 Tafeln u. 99 Text-Abbildgn. 318 Seiten. gr. 8°. Mk. 20⁹⁰.

NIEDENZU, DR. FRANZ. Handbuch für botanische Bestimmungsübungen. Mit 15 Figuren im Text. 351 Seiten. 8°. Mk. 4.

SCHAFFER, DR. KARL. Suggestion und Reflex. Eine Critisch-experimentelle Studie über die Reflexphänomene des Hypnotismus. Mit 6 Tafeln in Lichtdruck und 11 Abbildungen im Text. 113 Seiten. gr. 8°. Mk. 6⁹⁰.

SCHMIDT, DR. ALEX. Weitere Beiträge zur Blutlehre. Nach des Verfassers Tode herausgegeben. 247 Seiten. 8°. Mk. 7.

SCHWARTZE, TH. Die Lehre von der Electricität und deren praktische Verwendung. Mit 153 in den Text gedruckten Abbildungen. 543 Seiten. 8°. Mk. 10⁹⁰.

STEINHARDT, DR. EUGEN. Kurzes Lehrbuch der Chemie zum Gebrauch an Schulen und zur Selbstbelehrung. Zwei Theile. Erst. Theil; Anorganische Chemie. 418 Seiten. 8°. Mk. 6⁹⁰.

VAN BIERVLIET, J. J. Elements de psychologie humaine. Cours professé à l'université de Gand. Avec 34 figures dans le Text. 317 pages. frs. 8.

ZEITSCHRIFT FÜR ANGEWANDTE MIKROSKOPIE herausgegeben von G. Marpmann. Monthly. 1^{ter} Band 1^{tes} Heft. Per year, \$2.75.

ZEITSCHRIFT, Geographische, Herausgegeben von Dr. Alfred Hettner. 1^{er} Jahrg. 1^{es} Heft. Per year (12 N^{os}) \$4⁰⁰.

ZIMMERMANN, DR. A. Das Mikroskop. Ein Leitfaden der wissenschaftlichen Mikroskopie. Mit 231 Figuren im Text. 334 Seiten. gr. 8°. Mk. 9.

ZITTEL, KARL A. VON. Grundzüge der Paläontologie (Paläozoologie). Mit 2048 in den Text gedruckten Abbildungen. 971 Seiten. gr. 8°. $\frac{1}{2}$ mor. Mk. 25⁹⁰.

GUSTAV E. STECHERT,

810 Broadway, New York.

Macmillan & Co.'s New Publications

"Written in the true spirit of the Alpine Climber."

The Alps from End to End.

By SIR WILLIAM MARTIN CONWAY. With 100 Illustrations by A. D. McCORMICK. Large demy, 8vo, cloth, \$7.00.

"A high place among these books of climbing, which appeal to many who cannot climb as well as to all who can, will be taken by the very pleasant volume, 'The Alps from End to End.'"—*Times*.

"Written in the true spirit of the Alpine climber. The book contains a hundred full-page illustrations by that admirable portrayer of rock and ice scenery, Mr. A. D. McCormick."—*Scotsman*.

"As pleasant a possession as any record that this thrilling sport has inspired in its devotees."—*Daily Chronicle*.

"An Arctic Adventure."

Ice-Bound on Kolguev.

By AUBYN TREVOR-BATTYE, F. L. S., F. Z. S., etc. With numerous Illustrations and Drawings, and 3 Maps. Large 8vo, cloth, gilt top, \$7.00.

"The story is told in a delightfully simple and spontaneous manner. Mr. Trevor-Battye's simple and unaffected narrative enables us to learn a good deal."—*London Times*.

"From beginning to end the story of this adventure is outside the common lines. It is a tale of success of an odd kind."—*Spectator*.

"A volume enjoyable for its manner as it is interesting for its matter."—*Glasgow Herald*.

Lindsay. *An Introduction to the Study of Zoology.* By B. LINDSAY, C. S. of Girton College, Cambridge. With 124 Illustrations and Diagrams. Pp. xix+356, 12mo, cloth, \$1.60 net.

Economic Classics. Edited by W. J. ASHLEY. New volume. **Peasant Rents:** Being the First Half of an Essay on the Distribution of Wealth and on the Sources of Taxation. By RICHARD JONES, 1831. Pp. xii+207, 16mo, cloth, 75 cents.

Gillies. *The Theory and Practice of Counter-Irritation.* By H. CAMERON GILLIES, M. D. Pp. xii+236, 8vo, cloth, \$2.50.

The Climates and Baths of Great Britain. Being the Report of a Committee of the Royal Medical and Chirurgical Society of London. W. M. Ord, M. D., Chairman; A. E. Garrod, M. D., Hon. Secretary.

Vol. I. The Climates of the South of England, and the Chief Medicinal Springs of Great Britain. Map. Pp. vxi+640, 8vo, cloth, \$6.50 net.

Jenks—The History of the Australian Colonies (from their foundation to the year 1893). By EDWARD JENKS, M. A., Professor of Law in the University College, Liverpool, etc. 12mo, cloth, \$1.60 net. (*Cambridge Historical Series.*)

Guttman. *The Manufacture of Explosives.* A theoretical and practical treatise on the history, the physical and chemical properties and the manufacture of explosives. 2 vols., 8vo, cloth, \$9.00 net.

Drage. *The Problem of the Aged Poor.* By GEOFFREY DRAGE. Pp. xvii+375, 12mo, cloth, \$2.00.

Cambridge Natural Science Manuals. Physical Series. General Editor, R. T. GLAZEBROOK, M. A., F. R. S. **Solution and Electrolysis.** By WILLIAM CECIL DAMPIER WHETHAM, Fellow of Trinity College, Cambridge. Pp. viii+296, 12mo, cloth, \$1.90 net.

Giles.—A Short Manual of Comparative Philology for Classical Students. By P. GILES, M. A., Fellow and Lecturer of Emmanuel College, in the University of Cambridge. 16mo, cloth, \$3.00 net. (*Macmillan's Manuals for Students.*)

MACMILLAN & CO., 66 Fifth Avenue, New York.

SCIENCE

EDITORIAL COMMITTEE : S. NEWCOMB, Mathematics ; R. S. WOODWARD, Mechanics ; E. C. PICKERING, Astronomy ; T. C. MENDENHALL, Physics ; R. H. THURSTON, Engineering ; IRA REMSEN, Chemistry ; J. LE CONTE, Geology ; W. M. DAVIS, Physiography ; O. C. MARSH, Paleontology ; W. K. BROOKS, Invertebrate Zoölogy ; C. HART MERRIAM, Vertebrate Zoölogy ; S. H. SCUDDER, Entomology ; N. L. BRITTON, Botany ; HENRY F. OSBORN, General Biology ; H. P. BOWDITCH, Physiology ; J. S. BILLINGS, Hygiene ; J. MCKEEN CATTELL, Psychology ; DANIEL G. BRINTON, J. W. POWELL, Anthropology.

FRIDAY, AUGUST 30, 1895.

CONTENTS :

| | |
|--|-----|
| <i>The Aims of Anthropology</i> : DANIEL G. BRINTON..... | 241 |
| <i>The Providential Functions of Government with Special Reference to Natural Resources</i> : B. E. FERNOW | 252 |
| <i>Current Notes on Anthropology (XII.)</i> :—..... | 265 |
| ‘Carib Art’ and its Significance ; <i>Syphilis and Leprosy in Ancient America</i> ; <i>Prehistoric Botany</i> : D. G. BRINTON. | |
| <i>Current Notes on Physiography (XV.)</i> :—..... | 266 |
| <i>Lakes in the Austrian Alps</i> ; <i>Lofly Ballooning in Germany</i> : W. M. DAVIS. | |
| <i>Scientific Notes and News</i> :—..... | 267 |
| <i>The Huxley Memorial</i> ; <i>The French Association for the Advancement of Science</i> ; <i>The Relations of Physiological and Clinical Research</i> ; <i>General</i> . | |
| <i>Correspondence</i> :—..... | 271 |
| <i>Consciousness and Evolution</i> : J. MCKEEN CATTELL. | |
| <i>Scientific Literature</i> :—..... | 272 |
| <i>Beddard’s Text-book of Zoögeography</i> ; THEO. GILL ; <i>Rehmké’s Psychologie</i> : A. C. ARMSTRONG, JR. ; <i>Keyes’ Paleontology of Missouri</i> : U. S. GRANT. | |
| <i>New Books</i> | 276 |

MSS. intended for publication and books, etc., intended for review should be sent to the responsible editor, Prof. J. McKeen Cattell, Garrison on Hudson, N. Y. Subscriptions and advertisements should be sent to SCIENCE, 41 N. Queen St., Lancaster, Pa., or 41 East 49th St., New York.

THE AIMS OF ANTHROPOLOGY.*

A MODERN philosopher has advanced the maxim that what is first in thought is last in expression ; illustrating it by the rules of grammar, which are present even in un-

*Address by the retiring President of the American Association for the Advancement of Science, at the Springfield meeting, August 29, 1895.

written languages, whose speakers have no idea of syntax or parts of speech.*

It may be that this is the reason why man, who has ever been the most important creature to himself in existence, has never seriously and to the best of his abilities made a study of his own nature, its wants and its weaknesses, and how best he could satisfy the one and amend the other.

The branch of human learning which undertakes to do this is one of the newest of the sciences ; in fact, it has scarcely yet gained admission as a science at all, and is rather looked upon as a dilettante occupation, suited to persons of elegant leisure and retired old gentlemen, and without any very direct or visible practical applications of concern with the daily affairs of life.

It is with the intention of correcting this prevalent impression that I address you today. My endeavor will be to point out both the immediate and remote aims of the science of anthropology, and to illustrate by some examples the bearings they have, or surely soon will have, on the thoughts and acts of civilized communities and intelligent individuals.

It is well at the outset to say that I use the term anthropology in the sense in which it has been adopted by this Association, that is, to include the study of the whole

*Professor James Ferrier, in his *Institutes of Metaphysic*.

of man, his psychical as well as his physical nature, and the products of all his activities, whether in the past or in the present. By some writers, especially on the continent of Europe, the term anthropology is restricted to what we call physical anthropology or somatology, a limitation of the generic term which we cannot but deplore. Others again, and some of worthy note, would exclude from it the realm of history, confining it in time to the research of prehistoric epochs, and in extent to the investigation of savage nations.

I cannot too positively protest against such opinions. Thus 'cabinined, cribbed, confined,' it could never soar to that lofty eminence whence it could survey the whole course of the life of the species, note the development of its inborn tendencies, and mark the lines along which it has been moving since the first syllables of recorded time; for this, and nothing less than this, is the bold ambition toward which aspires this crowning bough of the tree of human knowledge.

You will readily understand from this the magnitude of the material which anthropology includes within its domain. First, it investigates the physical life of man in all its stages and in every direction. While he is still folded in the womb, it watches his embryonic progress through those lower forms, which seem the reminiscences of far-off stages of the evolution of the species, until the child is born unto the world, endowed with the heritage transmitted from innumerable ancestors and already rich in personal experiences from its prenatal life. These combined decide the individual's race and strain, and potently incline, if they do not absolutely coerce, his tastes and ambitions, his fears and hopes, his failure or success.

On the differences thus brought about, and later nourished by the environment, biology, as applied to the human species, is

based; and on them, as expressed in aggregates, ethnography, the separation of the species into subspecies and smaller groups, is founded. It has been observed that numerous and persistent, although often slight differences arose in remote times, independently, on each of the great continental areas, sufficient to characterize with accuracy these subspecies. We therefore give to such the terms 'races' or 'varieties' of man.

All these are the physical traits of man. They are studied by the anatomist, the embryologist, the physician; and the closest attention to them is indispensable, if we would attain a correct understanding of the creature man, and his position in the chain of organic life.

But there is another vast field of study wholly apart from this and even more fruitful in revelations. It illustrates man's mental or psychical nature, his passions and instincts, his emotions and thoughts, his powers of ratiocination, volition and expression. These are preserved and displayed subjectively in his governments and religions, his laws and his languages, his words and his writings; and, objectively, in his manufactures and structures, in the environment which he himself creates—in other words, in all that which we call the arts, be they 'hooked to some useful end,' or designed to give pleasure only.

It is not sufficient to study these as we find them in the present. We should learn little by such a procedure. What we are especially seeking is to discover their laws of growth, and this can only be done by tracing these outward expressions of the inward faculties step by step back to their incipency. This leads us inevitably to that branch of learning which is known as archaeology, 'the study of ancient things,' and more and more to that part of archaeology called prehistoric, for that concerns itself with the most ancient; and the most

ancient is the simplest, and the simplest is the most transparent, and therefore the most instructive.

Prehistoric archæology is a new science. I can remember when neither its name nor its methods were known to the most learned anthropologists. But it has already taught us by incontrovertible arguments a wonderful truth, a truth opposing and reducing to nought many teachings of the sages and seers of past generations. They imagined that the primal man had fallen from some high estate; that he had forfeited by his own falseness, or been driven by some hard fate, from a pristine Paradise, an Eden garden, an Arcady; that his ancestors were demi-gods and heroes, himself their degenerate descendant.

How has prehistoric archæology reversed this picture? We know beyond cavil or question that the earliest was also the lowest man, the most ignorant, the most brutish, naked, homeless, half-speechless. But the gloom surrounding this distant background of the race is relieved by rays of glory; for with knowledge not less positive are we assured that through all hither time, through seeming retrogressions and darkened epochs, the advance of the race in the main toward a condition better by every standard has been certain and steady, 'ne'er known retiring ebb, but kept due on.'

Archæology, however, is, after all, a dealing with dry bones, a series of inferences from inanimate objects. The color and the warmth of life, it never has. How can we divine the real meaning of the fragments and ruins, the forgotten symbols and the perished gods, it shows us?

The means has been found, and this through a discovery little less than marvelous, the most pregnant of all that anthropology has yet offered, not yet appreciated even by the learned. This discovery is that of the psychical unity of man, the parallelism of his development everywhere and in

all time; nay, more, the nigh absolute uniformity of his thoughts and actions, his aims and methods, when in the same degree of development, no matter where he is, or in what epoch living. Scarcely anything but his geographical environment, using that term in its larger sense, seems to modify the monotonous sameness of his creations.

I shall refer more than once to this discovery; for its full recognition is the corner stone of true anthropology. In this connection I refer to it for its application to archæology. It teaches us this: that when we find a living nation of low culture, we are safe in taking its modes of thought and feeling as analogous to those of extinct tribes whose remains show them to have been in about the same stage of culture.

This emphasizes the importance of a prolonged and profound investigation of the few savage tribes who still exist; for although none of them is as rude or as brutelike as primitive man, they stand nearest to his condition, and, moreover, so rapid nowadays is the extension of culture that probably not one of them will remain untouched by its presence another score of years.

Another discovery, also very recent, has enabled us to throw light on the prehistoric or forgotten past. We have found that much of it, thought to be long since dead, is still alive and in our midst, under forms easily enough recognized when our attention is directed to them. This branch of anthropology is known as Folklore. It investigates the stories, the superstitions, the beliefs and customs which prevail among the unlettered, the isolated and the young; for these are nothing less than survivals of the mythologies, the legal usages and the sacred rites of earlier generations. It is surprising to observe how much of the past we have been able to reconstruct from this humble and long neglected material.

From what I have already said, you will understand some of the aims of anthropology, those which I will call its 'immediate' aims. They are embraced in the collection of accurate information about man and men, about the individual and the group, as they exist now, and as they have existed at any and all times in the past; here where we are, and on every continent and island of the globe.

We desire to know about a man, his weight and his measure, the shape of his head, the color of his skin and the curl of his hair; we would pry into all his secrets and his habits, discover his deficiencies and debilities, learn his language, and inquire about his politics and his religion, yes, probe those recesses of his body and his soul which he conceals from wife and brother. This we would do with every man and every woman, and, not content with the doing it, we would register all these facts in tables and columns, so that they should become perpetual records, to which we give the name 'vital statistics.'

The generations of the past escape such personal investigation, but not our pursuit. We rifle their graves, measure their skulls, and analyze their bones; we carry to our museums the utensils and weapons, the gods and jewels, which sad and loving hands laid beside them; we dig up the foundations of their houses and cart off the monuments which their proud kings set up. Nothing is sacred to us; and yet nothing to us is vile or worthless. The broken pot-shoulder, the half-gnawed bone, cast on the refuse heap, conveys a message to us more pregnant with meaning, more indicative of what the people were, than the boastful inscription which their king caused to be engraved on royal marble.

This gleaming and gathering, this collecting and storing of facts about man from all quarters of the world and all epochs of his existence, is the first and indispensable aim

of anthropologic science. It is pressing and urgent beyond all other aims at this period of its existence as a science; for here more than elsewhere we feel the force of the Hippocratic warning, that the time is short and the opportunity fleeting. Every day there perish priceless relics of the past, every year the languages, the habits and the modes of thought of the surviving tribes which represent the earlier condition of the whole species, are increasingly transformed and lost through the extension of civilization. It devolves on the scholars of this generation to be up and doing in these fields of research; for those of the next will find many a chance lost forever, of which we can avail ourselves.

And here let me insert a few much needed words of counsel on this portion of my theme. Why is it that even in scientific circles so little attention is paid to the proper training of observers and collectors in anthropology?

We erect stately museums, we purchase costly specimens, we send out expensive expeditions; but where are the universities, the institutions of higher education, that train young men how to observe, how to explore and collect in this branch? As an eminent ethnologist has remarked, in any other department of science, in that, for instance, which deals with flowers or with butterflies, no institution would dream of sending a collector into the field who lacked all preliminary training in the line, or knowledge of it; but in anthropology the opinion seems universal that such preparation is quite needless.* Carlyle used to say that every man feels himself competent to be a gentleman farmer or a crown prince;

* See the pertinent remarks of Dr. S. R. Steinmetz in the *Einleitung* to his *Ethnologische Studien zur Ersten Entwicklung der Sprache* (Leiden, 1894). I have urged this point further in a pamphlet entitled *Anthropology; as a Science and as a branch of University Education in the United States* (Philadelphia, 1892).

our institutions seem to think that every man is competent to be an anthropologist and archæologist; and let a plausible explorer present himself, the last question put to him will be, whether he has any fitness for the job.

Hence our museums are crammed with doubtful specimens, vaguely located, and our volumes of travel with incomplete or wholly incorrect statements, worse than purely fictitious ones, because we know them to be the fruit of honest intentions, and therefore give them credit.

But, you will naturally ask, to what end this accumulating and collecting, this filling of museums with the art-products of savages and the ghastly contents of charnel houses? Why write down their stupid stories and make notes of their obscene rites? When it shall be done, or as good as done, what use can be made of them beyond satisfying a profitless curiosity?

This leads me to explain another branch of anthropology to which I have not yet alluded, one which introduces us to other aims of this science, quite distinct from those I have mentioned. That branch is Ethnology.

Ethnology in its true sense represents the application of the principles of inductive philosophy to the products of man's faculties. You are aware that that philosophy proceeds from observed facts alone; it discards all preconceived opinions concerning these facts; it renounces all allegiance to dogma, or doctrine or intuition; in short, to every form of statement that is not capable of verification. Its method of procedure is by comparison, that is, by the logical equations of similarity and diversity, of identity and difference; and on these it bases those generalizations which range the isolated fact under the general law, of which it is at once the exponent and the proof.

By such comparisons, ethnology aims to define in clear terms the influence which

the geographical and other environment exercises on the individual, the social group and the race; and, conversely, how much in each remains unaltered by the external forces, and what residual elements are left, defiant of surroundings, wholly personal, purely human. Thus, rising to wider and wider circles of observation and generalization, it will be able at last to offer a conclusive and exhaustive connotation of what man is—a necessary preliminary, mark you, to that other question, so often and so ignorantly answered in the past, as to what he should be.

Ethnology, however, does not and should not concern itself with this latter inquiry. Its own field is broad enough, and the harvest offered is rich enough. Its materials are drawn from the whole of history and from pre-history. Those writers who limit its scope to the explanation of the phenomena of primitive social life only have so done because these phenomena are simpler in such conditions, not that the methods of ethnology are applicable only to such. On the contrary, they are not merely suitable, they are necessary to all the facts of history, if we would learn their true meaning and import. The time will come, and that soon, when sound historians will adopt as their guide the principles and methods of ethnologic science, because by these alone can they assign to the isolated fact its right place in the vast structure of human development.

In the past, histories have told of little but of kings and their wars; some writers of recent date have remembered there is such a thing as the People, and have essayed to present its humble annals; but how few have even attempted to avail themselves of the myriad side-lights which ethnology can throw on the motives and the manners of a people, its impulses and acquisitions?

It is the constant aim of ethnology to

present its results free from bias. It deprecates alike enthusiasm and antipathy. Like Spinoza's God, *nullum amat, nullum odit*. Its aim is to compare dispassionately all the acts and arts of man, his philosophies and religions, his social schemes and personal plans, weighing and analyzing them, separating the local and temporal in them from the permanent and general, explaining the former by the conditions of time and place, referring the latter to the category of qualities which make up the oneness of humanity, the solid ground on which he who hereafter builds, 'will build for aye.'

This, then, briefly stated, is the aim of that department of anthropology which we call ethnology. In yet fewer words, its mission is 'to define the universal in humanity,' as distinguished from all those traits which are the products of fluctuating environments.

This universal, however, is to be discovered, not assumed. The fatal flaw in the arguments of most philosophers is that they frame a theory of what man is and what are the laws of his growth, and pile up proofs of these, neglecting the counter-evidence, and passing in silence what contradicts their hypotheses.

Take, for instance, the doctrine of evolution as applied to man. It is not only a doctrine but a dogma with many scientists. They look with theological ire on any one who questions it. I have already said that in the long run and the general average it has been true of man. But that we have any certainty that it will continue true is a mistake; or that it has been true of the vast majority of individuals or ethnic groups is another mistake. As the basis for a boastful and confident optimism it is as shaky as sand. Taken at its real value, as the provisional and partial result of our observations, it is a useful guide; but swallowed with unquestioning faith, as a final

law of the universe, it is not a whit more inspiring than the narrowest dogma of religious bigotry.

We have no right, indeed, to assume that there is anything universal in humanity until we have proved it. But this has been done. Its demonstration is the last and greatest conquest of ethnology, and it is so complete as to be bewildering. It has been brought about by the careful study of what are called 'ethnographic parallels,' that is, similarities or identities of laws, games, customs, myths, arts, etc., in primitive tribes located far asunder on the earth's surface. Able students, such as Bastian, Andree, Post, Steinmetz and others have collected so many of these parallels, often of seemingly the most artificial and capricious character, extending into such minute and apparently accidental details, from tribes almost antipodal to each other on the globe, that Dr. Post does not hesitate to say: "Such results leave no room for doubt that the psychical faculties of the individual as soon as they reach outward expression fall under the control of natural laws as fixed as those of inorganic nature."*

As the endless variety of arts and events in the culture history of different tribes in different places, or of the same tribe at different epochs, illustrates the variables in anthropologic science, so these independent parallelisms prove beyond cavil the ever-present constant in the problem, to wit, the one and unvarying psychical nature of man, guided by the same reason, swept by the same storms of passion and emotion, directed by the same will towards the same goals, availing itself of the same means when they are within reach, finding its pleasures in the same actions, lulling its fears with the same sedatives.

The anthropologist of to-day who, like a late distinguished scholar among ourselves,

* Dr. A. H. Post, 'Ethnologische Gedanken,' in *Globus*, Band 59, No. 19.

would claim that, because the rather complex social system of the Iroquois had a close parallel among the Munda tribes of the Punjab, therefore the ancestors of each must have come from a common culture center; or, who, like an eminent living English ethnologist, sees a proof of Asiatic relations in American culture because the Aztec game of *patolli* is like the East Indian game of *parchesi*—such an ethnologist, I say, may have contributed ably to his science in the past, but he does not know where it stands to-day. Its true position on this crucial question is thus tersely and admirably stated by Dr. Steinmetz: "The various customs, institutions, thoughts, etc., of different peoples are to be regarded either as the expressions of the different stadia of culture of our common humanity; or, as different reactions of that common humanity under varying conditions and circumstances. The one does not exclude the other. Therefore the concordance of two peoples in a custom, etc., should be explained by borrowing or by derivation from a common source only when there are special, known and controlling reasons indicating this; and when these are absent, the explanation should be either because the two peoples are on the same plane of culture, or because their surroundings are similar."*

This is true not only of the articles intended for use, to supply the necessities of existence, as weapons and huts and boats—we might anticipate that they would be something similar, otherwise they would not serve the purpose everywhere in view; but the analogies are, if anything, still more close and striking when we come to compare pure products of the fancy, creations of the imagination or the emotions, such as stories, myths and motives of decorative art.

It has proved very difficult for the comparative mythologist or the folk-lorist of

the old school to learn that the same stories, for instance, of the four rivers of Paradise, the flood, the ark and the patriarch who is saved in it, arose independently in western Asia, in Mexico and in South America, as well as in many intervening places, alike even in details, and yet neither borrowed one from the other, nor yet drawn from a common source. But until he understands this, he has not caught up with the progress of ethnologic science.

So it is also with the motives of primitive art, be they symbolic or merely decorative. How many volumes have been written tracing the migrations and connections of nations by the distribution of some art motive, say the *svastika*, the meander or the cross! And how little of value is left in all such speculations by the rigid analysis of primitive arts that we see in such works as Dr. Grosse's *Anfänge der Kunst*, or Dr. Haddon's attractive monograph on the 'Decorative Art of British New Guinea,' published last year! The latter sums up in these few and decisive words the result of such researches pursued on strictly inductive lines—"The same processes operate on the art of decoration whatever the subject, wherever the country, whenever the age." This is equally true of the myth and the folk-tale, of the symbol and the legend, of the religious ritual and the musical scale.

I have even attempted, I hope not rashly, to show that there are quite a number of important words in languages nowise related by origin or contact, which are phonetically the same or similar, not of the mimetic class, but arising from certain common relations of the physiological function of language; and I have urged that words of this class should not be accounted of value in studying the affiliations of language.*

* 'On the Physiological Correlation of certain Linguistic Radicals.' By D. G. Brinton. In the *Proceedings of the American Oriental Society*, March, 1894.

* Dr. S. R. Steinmetz, *ubi supra*, Einleitung.

And I have also endeavored to demonstrate that the sacredness which we observe attached to certain numbers, and the same numbers, in so many mythologies and customs the world over, is neither fortuitous, nor borrowed the one from the other; but depends on fixed relations which the human body bears to its surroundings, and the human mind to the laws of its own activity. And, therefore, that all such coincidences and their consequences—and it is surprising how far-reaching these are—do not belong to the similarities which reveal contact, but only to those which testify to psychical unity.*

So numerous and so amazing have these examples of culture-identities become of late years that they have led more than one student of ethnology into a denial of the freedom of the human will under any of the definitions of voluntary action. But the aims of ethnology are not so aspiring. It is strictly a natural science, dealing with outward things, to wit, the expressions of man's psychical life, endeavoring to ascertain the conditions of their appearance and disappearance, the organic laws of their birth, growth and decay. These laws must undoubtedly be correlated with certain mental traits, but it is not the business of the ethnologist to pursue them to their last analysis in the realm of metaphysics. For instance, we may trace all forms of punishment back to the individual's passion for revenge; or we may analyze all systems of religion until we find the common source of all to be man's dread of the unknown; and these will be sufficient ethnologic explanations of both these phenomena, but not a final analysis of the emotion of dread or the

*'The Origin of Sacred Numbers.' By D. G. Brinton. In the *American Anthropologist*, April, 1894. In my *Myths of the New World* (New York, 1868, Chapter III, 'The Sacred Number, its Origin and Applications'), I had shown the prepotency of the number *four* both in American and Old World mythology, ritual, statecraft, etc.

thirst for vengeance. Ethnology declines to enter these realms of abstractions.

I repeat that to define 'the universal in humanity' is the aim of ethnology, that is, the universal soul or *psyche* of humanity.

But let me not be understood as speaking of this as of some entity, like the *ame humaine* of the Comtists. That were sophistical word-mongering in the style of ancient scholasticism. There is no such entity as humanity, or race, or people, or nation. There is nothing but the individual man or woman, the 'single, separate person,' as Walt Whitman says. Hence some of the most advanced ethnologists are ready to give up the *ethnos* itself as a subject of study. Those terms so popular a few years ago, *Völkerpsychologie*, *Völkergedanken*, racial psychology, ethnic sentiments, and the like, are looked upon with distrust. The external proofs of the psychical unity of the whole species have multiplied so abundantly that some maintain strenuously that it is not ethnic or racial peculiarities, but solely external conditions on the one hand and individual faculties on other, which are the factors of culture-evolution.

While I admit that this question is still *sub judice*, I add that the position just stated seems to be erroneous. All members of the species have common human mental traits; that goes without saying; and in addition it seems to me that each of the great races, each ethnic group, has its own added special powers and special limitations compared with others; and that these ethnic and racial psychic peculiarities attached to all or nearly all members of the group are tremendously potent in deciding the result of its struggle for existence.

I must still deny that all races are equally endowed—or that the position with reference to civilization which the various ethnic groups hold to-day is one merely of opportunity and externalities. I must still claim that the definition of the *ethnos* is one

of the chief aims of ethnology, and that the terms of this definition are not satisfied by geographic explanations. Let me, with utmost brevity, name a few other connotations, prepotent, I believe, in the future fate of nations and races.

None, I maintain, can escape the mental correlations of its physical structure. The black, the brown and red races differ anatomically so much from the white, especially in their splanchnic organs, that even with equal cerebral capacity, they never could rival its results by equal efforts.

Again, there is in some stocks and some smaller ethnic groups a peculiar mental temperament which has become hereditary and general, of a nature to disqualify them for the atmosphere of modern enlightenment. Dr. Von Buschan has recently pointed out this as distinctly and racially pathologic; an inborn morbid tendency, constitutionally recreant to the codes of civilization, and therefore technically criminal.

Once more, one cannot but acknowledge that the relations of the emotional to the intellectual nature vary considerably and permanently in different ethnic groups. Nothing is more incorrect than the statement so often repeated by physicians that the modern civilized man has a more sensitive emotional system than the savage. The reverse is the case. Since the Dark Ages, Europe has not witnessed epidemic neuroses so violent as those still prevalent among rude tribes.

These and a number of similar traits separate races and peoples from each other by well marked idiosyncrasies, extending to the vast majority of their members and pregnant with power for weal or woe on their present fortunes and ultimate destinies. The patient and thorough investigations of these peculiarities is, therefore, one of the most apposite aims of modern ethnology.

In this sense we can speak of the *Volksgeist* and *Völkergedanken*, a racial mind, or the temperament of a people, with as much propriety and accuracy as we can of any of the physical traits which distinguish it from other peoples or races.

For the branch of anthropology which has for its field the investigation of these general mental traits, the Germans have proposed the name 'Characterology' (*Karakterologie*). Its aim is to examine the collective mental conditions and expressions of ethnic groups, and to point out wherein they differ from other groups and from humanity at large; also, to find through what causes these peculiarities came about, the genetic laws of their appearance, and the consequences to which they have given rise.

This branch of anthropology is that which offers a positive basis for legislation, politics and education, as applied to a given ethnic group; and it is only through its careful study and application that the best results of these can be attained, and not by the indiscriminate enforcement of general prescriptions, as has hitherto been the custom of governments.

The development of humanity as a whole has arisen from the differences of its component social parts, its races, nations, tribes. Their specific peculiarities have brought about the struggles which in the main have resulted in an advance. These peculiarities, as ascertained by objective investigation, supply the only sure foundation for legislation; not *a priori* notions of the rights of man, nor abstract theories of what should constitute a perfect state, as was the fashion with the older philosophies, and still is with the modern social reformers. The aim of the anthropologist in this practical field is to ascertain in all their details, such as religions, language, social life, notions of right and wrong, etc., wherein lie the idiosyncrasies of a given group, and frame its laws accordingly.

Perhaps what I have said sufficiently explains the aims of ethnology. Some one has pertinently called it 'the natural science of social life,' because its methods are strictly those of the natural sciences, and its material is supplied by man living in society.

The final arbiter, however, to whom it appeals, is, I repeat, not the *ethnos*, not the social group, but the individual. I think it was Goethe who, nearly a century ago, uttered the pithy remark: "Man makes genera and species; Nature makes only individuals." Hence, the justification of any result claimed by ethnology must come from the psychology of the individual; in his personal feelings and thoughts will be discovered the final and only complete explanation of the forms of sociology and the events of history. As I have elsewhere urged, man himself, the individual man, is the only final measure of his own activities, in whatever direction they are directed.*

On the other hand, the only rational psychology—using that term as a science of the mental processes—must be the outcome of anthropology conducted as a natural science. For thousands of years other plans have been pursued. The philosopher would delve in his 'inner consciousness;' the theologian would turn to his revelation; the historian would reason on his undigested facts; but the psychologist of the future, taking nothing for granted, will define the mentality of the race by analyzing each of its lines of action back to the individual feelings which gave them rise.

It is quite likely that some who have heard me thus far, and have agreed with

* "Man himself is the only final measure of his own activities. To his own force and faculties all other tests are in the end referred. All sciences and arts, all pleasures and pursuits, are assigned their respective ranks in his interest by reference to those physical powers and mental processes which are peculiarly the property of his own species." *Anthropology as a Science*, etc., p. 3.

me, are still dissatisfied. On their lips is that question which is so often put to, and which so often puzzles, the student of the sciences, *cui bono*. What practical worth have these analyses and generalizations which have been referred to?

Fortunately, the anthropologist is not puzzled. His science, like others, has its abstract side, seemingly remote from the interests of the workaday world; but it is also preëminently an applied science, one the practicality and immediate pertinence of which to daily affairs render it utilitarian in the highest degree.

Applied anthropology has for its aims to bring to bear on the improvement of the species, regarded on the one hand as groups, and on the other as individuals, the results obtained by ethnography, ethnology and psychology.

Such an improvement is broadly referred to as an increased or higher civilization; and it is the avowed aim of applied anthropology accurately to ascertain what are the criteria of civilization, what individual or social elements have in the past contributed most to it, how these can be continued and strengthened, and what new forces, if any, may be called in to hasten the progress. Certainly no aims could be more immediately practical than these.

Here again anthropology sharply opposes its methods to those of the ideologists, the dogmatists, and the deductive philosophers. It refuses to ask, What *should* improve man? but asks only, What *has* improved him in the past? and it is extremely cautious in its decision as to what 'improvement' really means. It certainly does not accept the definition which up to the present the philosophies and theologies have offered; any more than it accepts the means by which these claim that our present civilization has been brought about.

This department of anthropology is still in its infancy. We are only beginning to

appreciate that, in the future, political economy, like history, will have to be rearranged on lines which this new science dictates. The lessons of the past, their meaning clearly apprehended, will be acknowledged as the sole guides for the future. It may be true, as De Tocqueville said of the United States, that a new world needs a new political science; but the only sure foundation for the new will be the old.

Applied anthropology clearly recognizes that the improvement of humanity depends primarily on the correct adjustment of the group to the individual; and, as in ethnology, its ultimate reference is not to the group, but to the individual. In the words of John Stuart Mill, the first to apply inductive science to social evolution, it is that the individual may become 'happier, nobler, wiser,' that all social systems have any value.

We may profitably recall what the same profound thinker and logician tells us have been up to the present time the prime movers in human social progress. They are: first, property and its protection; second, knowledge and the opportunity to use it; and third, coöperation, or the application of knowledge and property to the benefit of the many.

But Mill was altogether too acute an observer not to perceive that while these moments have proved powerful stimulants to the group, they have often reacted injuriously on the individual, developing that morbid and remorseless egotism which is so prevalent in modern civilized communities. Nor should I omit to add that the remedy which he urged and believed adequate for this dangerous symptom is one which every anthropologist and every scientist will fully endorse—the general inculcation of the love of truth, scientific, verifiable truth.

It seems clear therefore that the teachings of anthropology, whether theoretical or practical, lead us back to the individual as the point of departure and also the

goal. The state was made for him, not he for the state; any improvement in the group must start by the improvement of its individual members. This may seem a truism, but how constantly it is overlooked in the most modern legislation and schemes of social amelioration! How many even of such a learned audience as this have carefully considered in what respects the individual man has improved since the beginning of historic time? Is he taller, stronger, more beautiful? Are his senses more acute, his love purer, his memory more retentive, his will firmer, his reason stronger? Can you answer me these questions correctly? I doubt it much. Yet if you cannot, what right have you to say that there is any improvement at all?

To be sure, there is less physical suffering, less pain. War and famine and bitter cold are not the sleuthhounds that they once were. The dungeons and flames of brutal laws and bigoted religions have mostly passed away. Life is on the average longer, its days of sickness fewer, justice is more within reach, mercy is more bountifully dispensed, the tender eye of pity is ever unscarfed.

But under what difficulties have these results been secured? What floods of tears and blood, what long wails of woe, sound down the centuries of the past, poured forth by humanity in its desperate struggle for a better life! A struggle which was blind, unconscious of its aims, unknowing of the means by which they should be obtained, groping in darkness for the track leading it knew not whither.

Ignorant of his past, ignorant of his real needs, ignorant of himself, man has blundered and stumbled up the thorny path of progress for tens of thousands of years. Mighty states, millions of individuals, have been hurled to destruction in the perilous ascent, mistaking the way, pursuing false paths, following blind guides.

Now anthropology steps in, the new Science of Man, offering the knowledge of what he has been and is, the young but wise teacher, revealing the future by the unwavering light of the past, offering itself as man's trusty mentor and friend, ready to conduct him by sure steps upward and onward to the highest summit which his nature is capable of attaining; and who dares set a limit to that?

This is the final aim of anthropology, the lofty ambition which the student of this science deliberately sets before himself. Who will point to a worthier or a nobler one?

DANIEL G. BRINTON.

UNIVERSITY OF PENNSYLVANIA.

*THE PROVIDENTIAL FUNCTIONS OF GOVERNMENT WITH SPECIAL REFERENCE TO NATURAL RESOURCES.**

It is with considerable hesitation that I undertake the duty which you have seen fit to impose upon me, namely, of addressing you in a representative manner on a subject of Economic Science. For I may not claim to be an expounder of its laws, although engaged in its practical application; much less do I pretend to be a representative of the science, if science it be.

This doubt alone, whether there is as yet such a thing as economic science, should unfit me for my present position before you, who have chosen this field of human inquiry as your specialty and hold it, I presume, as correlated with equal value to all the other sciences established as such.

But even conceding the right to such a correlation which I know is maintained practically by the most eminent men, I am still inclined to doubt the propriety of the title which is applied to this section of the Association for the Advancement of Science, for I conceive that the intention could

* Address of the Vice-President, Section I, American Association for the Advancement of Science, at the Springfield Meeting, August 29, 1895.

not have been to single out for representation in the great concourse of sciences one portion and one method of the greater separate field of inquiry, but that the title of Economic Science was in reality supposed or intended to be inclusive of all those branches of knowledge which deal with the phenomena of political, commercial, economic and social life of mankind, and which might be comprised in the all-inclusive name of Social Science, Anthropology in Section *H*, forming its historical or descriptive part.

At least since this section *I* was formed, if not before, it has been recognized that political economy, or economics, was only a branch of a larger science, the science of the social biology of man, and that this branch could not be satisfactorily developed for any length of time without reference to and without an equal development of all other branches of the system. Hence to be abreast with the times, at least in classification and nomenclature, we should rechristen this Section to be the Section of Social Science, which to my mind would assign it its proper place in the concourse of sciences represented in the Association. Social Science would then have to determine the forces and laws and to explain the phenomena of social life, and finally, as applied social science, to direct the development of the political, economic, commercial and social intercourse of man; these four aspects of social life being all inclusive and at the same time so differentiated as to admit of their more or less separate study and largely, never entirely, independent development.

Perhaps I owe you an explanation, if not an apology, for my doubt as to whether we are *as yet* justified in classing this branch of knowledge as a science. This doubt, which I notice is shared by others, has arisen from the observation that the discussions in this field are still progressing to a very large ex-

tent on a *a priori* reasoning, instead of a *posteriori*, as true science demands. The scientific method of procedure is too often neglected.

It seems that as yet both writers and practitioners rely more upon proposed working theories than upon discovered laws, and hence we find the economists divided into camps and schools, differing in the most fundamental principles; partisanship, preferences, bias of education, personal opinion, sentiment, dogmatism, rather than facts, truths, and natural laws, predicating unalterable consequences, are at the very foundation of the superstructure.

All science, to be sure, requires working theories as methods for further development, and in these there may be differences of conception which lead to diversity of opinion as to the probable truth, such as the dynamic and fluid theory of electricity, the undulatory and corpuscular theory of light. But these theories are the scaffolding outside of the unfinished building, not the foundation that is placed on broad unalterable law, on facts observed, which can be tested, and it is the organized and related condition of these facts and laws, their 'cause and effect,' interdependence, their structural aggregation which gives to the building its name and character of 'Science,' although the building may not yet be, never is to be, finished.

Do we have such a substructure and sufficient foundation walls for social science, or even for that part which has been most developed, Political and Economic Science, to deserve its appellation, or is it only a scaffolding from which to work in the erection of the building with a few isolated foundations of some of its walls, not too firmly placed and often lacking connection and mutual support?

Is not even the plan of the building so ill understood that the masons on each of the four walls have worked independently,

without reference to what the whole is to be, and some of them think that they are building an independent and separate structure instead of an integral part of the whole; so that, for instance, the worker on the economic side is jealous of and quarrelling with the sociologist? (*Vide* Discussion in the latest Proceedings of Am. Economic Association.)

It was not, however, my purpose to carp about names and classification, although I believe that proper nomenclature and classification assist greatly in advancing science; or to quarrel with the builders, except to warn them against dogmatism, which is unscientific, and against narrow conceptions of the sphere of their work, which is detrimental to its efficiency. I wish to emphasize that foundations are still needed on which to erect the building of social science and mutual supports for the walls, that have hitherto been left to stand independent; that the forces and stresses need to be more carefully calculated and their direction determined with more precision before the building may satisfactorily proceed. Finally, I desired to use this occasion for calling the attention of the workers on this building to the advantages they could derive for their fundamental work in this Association, which affords intercourse with the workers in other biological sciences, an advantage which the student of Social Science cannot afford to neglect.

While thus I desire to emphasize the advantages that come from such association, it will be part of my theme to point out the danger and impropriety of considering the social development of man as closely analogous to, nay, as of the same order as the biological development of plant and animal, an impropriety which is perpetrated by that school which has potently influenced economic thought for many decades, known as individualists, with Herbert Spencer as their most powerful exponent.

The revolution, which the fascinating philosophy of Darwin has brought into the manner of contemplating and explaining the life and development of plant and animal world, has with these men asserted itself in their manner of contemplating and explaining man's life. To be sure the same forces which determine the progress of development in plant and animal world are also active in the human world. We may easily agree that the same means employed in their struggle for existence, namely: selection, rejection, competition and adaptation, are also means which aid in the perpetuation, development and improvement of the human race, or its better adaptation to the conditions of existence.

So far as the simple *biologic* development of man is concerned, this may readily be conceded; and even in *social* development these forces were perhaps alone at work in the earliest history of mankind, when it just emerged from the state of mere brutishness, and are the only ones in some portions of it even now. But if we content ourselves to accept these same forces and means as the only ones now at work in shaping *social* development, we shall fail in understanding, explaining or directing that development. The two qualities by which the human individual differs from the brute, the head and the heart, the intellect and the soul, the reason and the emotions, feelings, affections—breeding the 'one wisdom, and the other character, the one directing, the other impelling action—have had, and will in future have still more influence upon the social development of the race. It is the existence and powerful influence of these two factors, these additional variables, in the social development, that have rendered its analysis so difficult, and that have kept our knowledge of human affairs from becoming an exact science sooner.

We do not deny the existence of the germs of these two qualities and occasional ex-

hibition of the same in the animal, but the capacity of developing them, as far as we know, is possessed by man to such an infinitely greater degree as to approach difference in kind.

With these two qualities two new aims were added to those which man has in common with the rest of living creation, namely, to secure the development of these two qualities; but, what is more important in his social development, they lead him and enable him to interfere with the working of the natural laws of physical development, to give direction to that development without the necessity of the struggle for existence as motive, and to even influence and transform the conditions of existence, which necessitated the struggle.

These qualities develop, however, only in society to such a degree as to become the moving force of further social progress. Associated effort has bred and fed them. At first probably the same instinct that moves the ants and bees and other animals to association was alone active in man, but as these two qualities developed by application they became the directive forces both of individual and social effort, and became stronger than the mere biologic forces.

Not that thereby human development becomes a 'bewildering exception to the reign of universal law'—a kind of solitary and mysterious island in the midst of the cosmos given over to strife of forces without clue or meaning; for morals and reason also develop under laws, but the development becomes more complex, a function of more variables, a result not of physical, but psychic forces as well, and of rational deliberation.

If the progress of man in his higher social development had relied on biologic forces alone, it is not likely that he would have exceeded the stage in which we find the lowest savages, who, with all the faculties of higher man latent, and the biologic laws

almost alone active, remain on the plane of the animal.

To quote Professor Joseph Le Conte: "I have from time to time shown that there are certain limitations to the application of the doctrines and methods of biology to sociology—that in every case such limitation is the result of the introduction of some new principle characteristic of *humanity* as distinguished from *animality*, of *reason* as distinguished from *instinct*."^{*}

And Lester F. Ward, after careful analysis, goes so far as to state rather strongly: "that the whole farrago which has so long passed for political economy is true only of irrational animals and is altogether inapplicable to rational man."[†]

Whatever value then all the other evolutionary, biologic forces pure and simple, have had in the *animal* development of man, in the *social* development, in the progress of moral and material civilization, the feelings, emotions or affections have played a much more important part, which has generally been greatly undervalued, until Lester F. Ward, in his *Dynamic Sociology*, and again in his *Psychic Factors of Civilization*, called forcibly attention to this fact. He recognizes these, however, only as dynamic forces, without direction, conceding to the intellect alone the power of direction. I am not prepared to deny altogether direction to the emotions, just as the force of gravity is both dynamic and directive. I am inclined to keep these two exhibits of the human mind distinctly and separably as two social forces of unequal value and direction, giving to the emotions the highest value in the past, to the intellect a more and more increasing importance, and modifying the direction of the former. At any rate we shall have to agree that the emotions have had and have the largest share in shaping men's civilization, and the rec-

ognition of this fact will appear as important with regard to the subject I have proposed to discuss.

Neither the individualists nor the socialists have recognized this notable fact which history develops at every step. The latter, *i. e.*, the *rational* socialists, in their plans of improvement of social conditions, fail to take account of it as well as of the biologic factors. They propose to hasten the millennium by making coöperation compulsory and reason rule supreme, suppressing the *individual* as in a colony of ants, each existing only as a part of the whole.

The individualists, on the other hand, desire to let our progress depend or to shape itself entirely under the working of the natural law of competition, suppressing as far as possible the *organization* which has served to develop the moral and intellectual forces, in fact they propose to reduce us as far as possible to the conditions of the brute world. They expect, to be sure, but with what right it is difficult to see, that the individuals will as such, independently of society, develop the social instinct, will desire the common good even at the expense of his own good, and finally, will seek voluntarily coöperation as a result of superior intelligence. And they claim that he will do so sooner and with less friction if let alone. It is not very clear why such a result should occur, how the free exercise of competition is to produce coöperation, which is its very antithesis. "Coöperation," as Ward states it, "always tends to reduce competition, and competition denotes want of coöperation;" and he further points out that the seeming coöperation as a result of competition is in reality only competition between corporations or classes, but in no sense the coöperation which establishes the same aims in all members of the society.

"We are told," says he, "to let things alone and to let nature take its course. But has intelligent man ever done this? Is

* Pop. Sci. Mo., Feb., 1879, p. 430.

† *Psychic Factors*. Ward. P. 279.

not civilization itself, with all that it has accomplished, the result of man's not letting things alone, of his not letting nature take its course?"*

In other words, the whole difference between civilization and other forms of natural progress is that it is a product of art, of artful coöperation; and this coöperation has been coerced rather than voluntary, coerced first by the few, and, as intellectual and moral forces developed, by the many.

And now we are asked to give up the advantage of this coöperation, laboriously developed, to return to the beginning as far as that is possible; and for what?—to experiment, and see whether the individual if left alone to the laws of competition would not again develop coöperation, which after all even the individualist admits with chagrin is preferable to competition.

To quote Ward again: "Competition not only involves the enormous waste, which has been described, but it prevents the maximum development, since the best that can be obtained under its influence is far inferior to that which is easily obtained by the artificial, *i. e.*, the rational and intelligent removal of that influence. Hard as it seems to be for modern philosophers to understand this, it was one of the first truths that dawned upon the human intellect. Consciously or unconsciously, it was felt from the very outset that the mission of mind was to grapple with the law of competition and, as far as possible, to resist and defeat it. The iron law of nature, as it may be appropriately called, was everywhere found to lie athwart the path of human progress; and the whole upward struggle of rational man, whether physical, social or moral, has been with this tyrant of nature—the law of competition—and in so far as he has progressed at all beyond the purely animal stage he has done so triumphing little

* *Psychic Factors*, Ward, p. 286.

by little over this law and gaining somewhat the mastery in the struggle."*

The individualists who expect better success from the purely animal method have been led by the undeniable fact that, in many respects, governments have failed to perform their functions well, although even in this respect fair investigation will show that, considering the conditions and the general limitations of men, this stricture cannot be sustained to the degree that may at first glance appear to the casual observer. Now, instead of improving the methods of government, they propose to curtail the functions; instead of giving direction to the social forces—which will not be downed—they propose to neglect them, to substitute the biologic forces.

Just as the chemists, who are attempting to determine dietaries and construct universal soups by chemical synthesis, overlook the existence and claims of the palate, catering alone to the stomach, so the individualists and many economists deal with man as a machine of a given physiological construction and put in motion by physiological forces, overlooking that psychological forces are his main motive power, 'that he is to be lured, not pushed, in the way of productive effort,' or, at least, that however far for his animal development the laws of animal biology, the laws of nature, may be allowed to prevail for his truly human development, the laws of mind, and especially of heart, must and will interfere. In this development, not competition, but coöperation, is a necessity.

This rather lengthy reference to that school of sociologists whose motto is the reduction of the functions of government, who have so strongly influenced and still continue to influence, not only thought, but government activity, appears necessary, whenever we desire to discuss government functions, for whether we subscribe to the

* *Psychic Forces*, Ward, p. 261.

views of the *laissez-faire* school, or to those of what we may call in contradistinction the *faire-marcher* school, the discussion will take a different turn.

Between the socialist and the individualist stands the true democrat, in whose creed society, the demos, stands recognized as the supreme ruler with ideals of progressive civilization as the goal of associated effort, giving all liberty possible to individual activity that does not interfere with the good of society. That good he believes to be the moral and intellectual development and material comfort of all its members, present and future, and he believes that it is attained not by negative, or merely restrictive methods, but by positive, active methods; ameliorative, or coercive, whenever the interests of society, present or future, would suffer by non-interference with individual activity or neglect. The functions of his government lie wherever coöperation of the whole will accomplish the end aimed at by society better than individual effort, avoiding interference where individual effort suffices to obtain the end of society; above all, he does not consider government as an evil and outside of himself, but as a good created by himself for the attainment of his highest human ideals, and furthermore, he always contends for the welfare of the future as well as of the present. This is the creed to which I subscribe, and until sociologic science furnishes us with the knowledge of fundamental, incontrovertible laws which with unflinching necessity produce invariable effects, we will have to state our creeds before preaching; this may not be a very scientific proceeding, but where, as I have stated, emotions play such a prominent part science and exact reasoning must suffer.

"The end of government is the good of mankind!" This briefest and broadest statement of the purpose of government, which breathes the true philosophical spirit of Locke, is much less a formula, as Huxley

calls it, or a working theory, than a historical fact, expressive of the visible trend which the evolutionary development of society has taken and which the careful student of the history of mankind can now deduce much more readily than even Locke; the broadly humanitarian tendencies of the governments of to-day, as compared with those of old, stand out unmistakably in spite of the many narrow, clannish policies that still prevail.

Yet the active politician or statesman would hardly find it practicable to formulate and direct the measures and methods for such an end on such a broad basis. He requires limitations. If he succeeds in accomplishing or promoting the good of that portion of mankind which is segregated as a nation, he may feel satisfied that he has also done his part in promoting the good of mankind.

There may then, to be sure, still remain antagonisms among the various governments which have to be smoothed away in that dim future which is the dream of the individualist, when the true '*Civitas dei*,' the ideal nation comprising all mankind, is to materialize; "in which every man's moral faculty shall be such as leads him to control all those desires which run counter to the good of mankind and to cherish only those which conduce to the welfare of society." (Huxley, *Nihilism*.)

For the present this cosmopolitan activity appears premature even to discuss. We will do well, therefore, to hold fast to the wisdom of minding our own affairs, to regulate our own government in such a manner as to attain the good of our own nation.

However poorly at times this end of government has been attained or attempted in practice, however its functions have been perverted, however diverse the methods employed, the conception that government exists for the purpose of the good of the aggregation of mankind to which it extends,

may be asserted to have now universal acceptance among all peoples. The questions on which people differ are as to how the good of the nation is to be attained; it is as to methods, rather than objects, that diversity of opinion has always prevailed.

Even the individualist, when closely pressed and not too callous, will agree to this object of government, but he will insist that this object, the good of the nation, is attained by inactivity rather than by active exertion of the government, by allowing the individuals to work out their own salvation (or damnation) amid the free and unrestricted play of natural forces, rather than by making them do so. *Laissez-faire* instead of *Faire-Marcher!*

They overlook that the objects and the motives which inspire the action of the individual as such are and will remain entirely different from those of the aggregation of individuals. As individual he will strive and does strive to work out that 'unsocial peculiarity of desiring to have everything his own way and opposing others.' Beyond the gratification of his own desires and an interest in his immediate offspring and perhaps in the second generation, he lacks as individual, and naturally so, incentive to advance or to calculate with the future. It is only as citizen, a member of organized society, as a social being, in community with others, as a reasoner and philosopher with conceptions of the objects and aims not only of individual existence, but of society as a whole, of the race, that he allows considerations of the future to influence his action, that he realizes the higher human ideals; in this communal activity 'he feels that he becomes more a man.'

Social man, then, is not satisfied alone with the preservation of his species by means of unconscious adaptation to its surroundings, but *consciously* he adapts himself to his surroundings and, more than that, he influences and adapts the surroundings

to himself, nay, he influences the future consciously, and therein, if in nothing else, he differs from the animal world and has outgrown the laws of their development.

How this has come to be so we need not inquire; it is so, that is enough. It is the momentum of education, of gradually accumulated tendencies that drives him on the path towards social and ethical improvement, with ideals in the future always before him. What we call the feeling of duty, which is the motive spring of most men's altruistic actions, is nothing but this momentum, which the accumulated education of generations has imparted to us and which produces the conscious civilizatory progress of the race, always setting up new ideals when the old ones have been attained, or when reason has dislodged them.

This civilizatory tendency has been upheld, however, only in the association, and is lost sight of by the individual as soon as he is dissociated and acts apart from his fellow members. This sounds like a paradox, that the tendencies and desires of the whole and its action should differ from the tendencies, desires and actions of its parts.

Yet even the sage of antiquity, Aristotle, recognized that you could never arrive at the whole by a mere addition of the units composing it, that while the prosperity of the whole implied the prosperity of all individuals which it includes, yet in our treatment of social questions we must proceed from the standpoint of society, not from that of the individual, the welfare of society could not be secured by attention to individual claims. And we observe this every day in larger or smaller assemblies of men; the emotions, feelings, provoked in the assembly lead to entirely different actions than if each member separately had acted on his own motion. The feeling of patriotism, which inspires many actions of nations and is of a kind with the civilizatory tendencies referred to, can hardly be

thought of outside of organized association, and so all the altruistic and ideal aspirations of the best and most advanced apostles of humanity, which have in view the improvement of the conditions of the future, the advancement of the race, are not of an individualistic but of communist nature, possible only in society and attainable only by associated effort.

Government then, the instrument of associated action, the expedient of organized society, the brain and hand of the nation, becomes the means not only of securing social existence, but social progress, and out of this object of government arises what I have called the providential functions of government, which have in view the future of the nation, as contrasted with the current functions of government, which refer to the more immediate needs of social, political, commercial and economic intercourse.

Government becomes the representative not only of communal interests as against individual interests, but also of future interests as against those of the present. Its object is not only for the day, but includes the *perpetuity* of the well-being of society and the perpetuity of such favorable conditions as will conduce to the *continued* welfare and improvement of the same; in short, its activity must be with regard to continuity, must provide for the future, must be providential.

Mark, we do not create this special providence for the individual, but for society; the individual will have to work out his own salvation to a large extent with the opportunities for advancement offered by society, but society itself can only act through the state or government, and as the representative of the future the state cannot, like the individual, 'let the future take care of itself.'

In our present state activity and legislation there is as yet but little realization of its providential character. Even the ques-

tion of education, which partakes of that character providing in part for future improvement, is only imperfectly considered from this point of view. The questions of the franchise as well as that of immigration, both of which are of greatest influence upon the future composition and condition of our society, are much more often discussed with reference to the rights of present members than with reference to the future of society.

The one condition of social life in which the action of the present influences the future almost more than in any other direction, namely, the condition of the means of material existence and their economical use (the economy of resources) has received perhaps the least recognition in practice as well as in theoretical discussion; and especially is this absence of attention to this most important branch of economics noticeable in English literature.

The reason probably is that the need of careful analysis of this factor of social life has as yet not been pressing. But as the world has been explored in all corners and the extent of its resources has become more nearly known, and as it is being rapidly peopled everywhere and the causes of depopulation are becoming less, the warnings of Malthus and Mill come home to us with new force and the study of the nature, relation to social life and development, and the economy of resources becomes a most important branch of social science, which will overshadow some of the other branches now appearing all important. When the questions of the extension of suffrage to women, of tariff, of taxation, of coinage and currency, which are all merely incidents, will have sunk into the background; the question of the economy of the resources which constitute and sustain the political, commercial and social power of the nation, long neglected, will still claim attention, for only those nations who develop their

national resources economically and avoid the waste of that which they produce can maintain their power or even secure the continuance of their separate existence. A nation may cease to exist as well by the decay of its resources as by the extinction of its patriotic spirit.

Whether we have a high tariff or no tariff, an income tax or a head tax, direct or indirect taxation, bimetalism or a single standard, national banks or state banks, are matters which concern, to be sure, the temporary convenience of the members of society, but their prejudicial adjustment is easily remediable; when ill effects become apparent, the inconveniences may be removed with but little harm to the community and none to mankind at large or to the future. But whether fertile lands are turned into deserts, forests into waste places, brooks into torrents, rivers changed from means of power and intercourse into means of destruction and desolation, these are questions which concern the material existence itself of society, and since such changes become often irreversible, the damage irremediable, and at the same time the extent of available resources becomes smaller in proportion to population, their consideration is finally much more important than those other questions of the day.

It is true that as individuals the knowledge of the near exhaustion of the anthracite coal fields does not induce any of us to deny ourselves a single scuttle of coal so as to make the coal field last for one more generation, unless this knowledge is reflected in increased price. But we can conceive that, as members of society, we may for that very purpose refuse to allow each other or the miner to waste unnecessarily. That this conception is not absurd and may be practically realized without any strain in our conceptions of government functions, is proved by the fact that it has been carried out in practice in several cases without opposition.

Absurdly enough we have begun such action with reference to our resources where it is perhaps of least consequence, as for instance, when by the establishment of hunting and fishing seasons and by other restrictions we seek to prevent the exhaustion of the fish and game resources. This is a good illustration of the fact that emotion rather than reason, sentiment rather than argument, are the prime movers of society. It was hardly fear of the exhaustion of this readily restorable resource, and economic reasons that lead to this protection of our fisheries and game, but love of sport that gave the incentive. And again it needed the love of sport, to set on foot the movement for the improvement of the roads in the United States, which the realization of true economy had not the power to bring about.

In some countries the waste of forest resources is more or less guarded against and the waste of water is at least to some extent a matter of control by society.

While we do not prevent single individuals from ruining themselves financially and hazarding the future of their families, we do prevent associated portions of the community, corporations, towns and cities, from jeopardizing their future by preventing them from extravagant expenditures and contracting of debts. This, too, is perhaps less designed for the future than to protect present members against undesirable burdens.

There are enough precedents established to show that whatever the greed and selfishness of the individual may dictate, society recognizes its right to interfere with the individual not only for its present objects, but even for considerations of the future.

To recognize how far any of the resources must become objects of national concern, it is necessary to understand their relative significance for the present and for the future development of society or of the particular nation. From this point of view I

have at some former occasion classified the resources under four heads, namely :

1. Resources inexhaustible.
2. Resources exhaustible and non-restorable.
3. Resources restorable, but liable to deterioration under increased activity.
4. Resources restorable, and apt to yield increased returns to increased activity.

Of the first class, hardly any one can be mentioned that are usually denominated as resources ; land, water, air and the forces of nature would fall under this class, but since it is not so much these things themselves as the conditions in which they are found that make them resources, and since these conditions are alterable by human agency, their inexhaustibility with reference to human requirements is not entirely established. With the land it is rather the fertility of the soil that makes it a resource, except so far as it serves for building purposes. With the water, except for the absolute necessity of life, it is its desirable distribution—terrestrial and atmospheric—which constitutes it a resource in the sense of satisfying human wants.

Of such resources as are in time exhaustible without the possibility of reproduction we may mention the mines. The supply of coal, 'the bread of industries,' in Europe is calculated to last not more than three or four centuries, although scarcity is expected long before that time, and in our own country we are told that anthracite coal mines do not promise more than sixty years of supply under present methods of working. The silver and gold mines, upon the basis of which Nevada became a State, are said to show signs of exhaustion. Oil fields and natural gas wells of very recent discovery belong to this class of exhaustible resources; with their consumption in satisfying our wants they are destroyed forever.

The timber of the virgin forest and its game, the water power of the streams,

largely dependent on the conditions of the former, the fisheries, and to some extent the local climate conditions, are resources of the third order, capable in most instances, of reproduction or restoration under human care, after having been deteriorated by uneconomic exploitation, or by change of contingent conditions, as when brooks and rivers are lessened in volume or else filled with flood waters and debris in consequence of forest destruction.

Lastly, as resources restorable and yielding increased returns to increased activity we would find most of those resources which are the product of human labor, industry and ingenuity; the accumulated educational fund and other conditions of civilization, the people themselves, capable of performing labor.

It might appear that of the natural resources, the soil with its fertility, capable under intensive cultivation of increasing its yield, should be placed here, but when this increased activity is unaccompanied by rational methods this resource too will deteriorate almost to a degree where its restoration is practically precluded.

Altogether, while possibility of restoration has served in our classification, practicability, *i. e.*, the relation of expenditure of energy and money to the result will have to influence the ranging of the resources in these classes as far as state activity with regard to them is called for.

Often it will be a difficult task to assign a particular resource to a proper position with regard to its bearing upon social interest, but conservatism, which is the logical policy of society, will lead us in cases of doubt to lean toward the presumption that the interests of society are more likely to suffer than those of the individual; and a mistake in curtailing private interests will be more surely and easily corrected than a mistake in not having in time guarded social interests.

To properly appreciate the position in any given case, we will have to weigh the present and future significance of the resource, the likelihood of its permanence, and the likelihood of its fate under private treatment, whence the necessity of bringing it under sovereign control of the state and the quality of the control will appear.

That each individual case will require its own consideration and adjudication holds there as well as with legislation in reference to industrial action, and the general classification here attempted offers simply a suggestion as to the general points of view from which each case must be considered.

With the conception of the government before us as outlined, namely, as the instrument to secure the possibility not only of social life, but of social progress, the representative of communal interests as against private interests, of the future as against the present, we can get an idea as to how far the providential functions of the state are to be called into action.

The policy of governmental control over waterways, roads and lands, falling under the operation of eminent domain, is well established in most governments. The ownership and management of railways has proved itself as in the interests of society in several countries. It should be extended with even more reason to all exhaustible, non-restorable resources. That in the interest of society and of production as well, the mines should belong to the state in order to prevent waste, we may learn from the actual experience of France, where they are state property and only the right to work them under supervision is leased to private individuals.

Of the restorable resources it is apparent that with regard to those which yield increased returns to increased labor, the interests of society and of the individual run on parallel lines. Where interference of the

state in their behalf exists, it is not from providential reasons; the amelioration functions only are called into requisition. Whatever tends to stimulate private activity is to be promoted, whatever retards development of intensive methods to be removed by government. Industrial education, cultural surveys, bureaus of information, experiment stations, and other aids to private enterprise, constitute the chief methods of expressing state interest with regard to these resources.

The three great resources upon which mankind is most dependent, and which, therefore, demand first and foremost the attention of the state are the soil as food-producer, the water and the climatic conditions. The utilization of these three prime resources by agriculture forms the foundation of all other industries, or as Sully puts it: "Tillage and pasturage are the two breasts of the state." It is true the manufacturer increases the utility of things, but the farmer multiplies commodities; he is creative, and he therefore above all others can claim a right to first consideration on the part of the state.

Whatever may be thought of the practicability of Mr. George's plans and of his conclusions, the fundamental principle upon which he bases his land theories will have to be admitted as correct. Society, the state, is the original owner of the soil. Whether the ownership should continue is another question.

The soil is a valuable resource as far as it is fertile and capable of agricultural production; the fertility, while liable to deterioration, can, with few exceptions, be said to be restorable, and it certainly yields increased returns to intelligent increased labor. It ranks, therefore, with those resources which can be left to private enterprise, calling only for the ameliorative functions of the government. But while this condition prevails, when the soil is put to

agricultural use, it does not exist as long as the soil is not so utilized. By the withdrawal of large sections of land from such use, society is harmed and deprived of the benefit which it would derive from a use of its property. The proper distribution and the appropriation of the soil to proper use form, therefore, fit functions of government control.

The rational appropriation of soil (land) to either farm use, pasturage or timber production, one would be inclined to think, could be left to the regulation of private intelligence; yet the fact is that the thin rocky soils of mountain districts are worked for a scanty agricultural crop, when they should be left to timber; while thousands of acres in fertile valleys are still under the shade of virgin forests.

Water and climate are the accessories to agricultural production and supplement the resources of the soil. Not objects of private enterprise directly, except in a limited manner, it is evident that, as far as they or the conditions which influence them can be at all controlled, they should be under the direct control of the state.

A rational management of the water capital of the world, in connection with agricultural use of the soil, will become the economic problem of the highest importance as the necessity for increased food production calls for intensive methods. And in connection with this problem, it must become a matter of state interest by a rational management of existing forests and by reforestation at the head waters of rivers and on the plains to secure the conditions which make a rational utilization of the waters possible. For without forest management, no water management is for any length of time possible, no stable basis for continued productive agriculture, industries and commerce.

I may be allowed for the sake of illustration to state more in detail the considera-

tions which pertain to the one resource with which I am most familiar, the forest.

The virgin forest is a natural resource, which answers two purposes of civilized society. On the one hand it furnishes directly desirable material; on the other hand it forms a condition of soil cover, which influences directly or indirectly, under its own cover and at a distance, conditions of water-flow, of soil and of local climate.

To the individual it is in the first place the timber, the accumulated growth of centuries, which has an interest to him and which he exploits for the purpose of making a profit on his labor and outlay. The relation of the forest to other conditions, direct or indirect, immediate or future, hardly ever enters into his calculations. Now the exploitation of this resource is a necessity of our civilization, but the economic conditions of our country and for that of any new or partially developed country, especially the condition of the distribution of population and consequent necessity for a long haul of the bulky material, bring it about, that only the best kinds of timber and the best cuts of these can be profitably moved to market. Hence, since profit is the object, exploitation is by necessity wasteful.

Again culling the forest, which means removing the good kinds, although apparently not as destructive to the resource as clean cutting, leaves the ground to the kinds not useful or less useful to man, to the weeds of the forest. This means not only occupation of the ground by undesirable kinds, but prevention of the reproduction of desirable kinds, which being reduced in numbers, hence are at a disadvantage in the struggle for existence and especially in the struggle for the necessary light under the shade of the growth that was left.

Thus even under legitimate exploitation, such as the interests of the individual exploiter and the economic conditions of the

country predicate, the future of the resource must be injured, its value deteriorated by changing its composition and quality.

Now comes the further danger of neglect which arises from the fact that when the marketable timber is gone the interest of the individual in the forest is also gone. The conflagrations which follow the wasteful exploitation with the accumulated debris of timber operations left in the woods kill and damage not only the remaining old timber, but all the young growth of desirable kinds. An additional vegetation of weeds, tree weeds as well as others, adapt themselves to the new conditions and further prevent the reestablishment of desirable kinds. Often these fires burn out the soil itself, which consists of the mould from the decay of litter accumulated through centuries, and thus not only the practicability but the possibility of restoration is prevented.

Thus by leaving this resource to the unrestricted activity of private individual interests it is quickly exhausted, its restoration is made difficult and sometimes impossible, its function as a material resource is destroyed.

It is possible to so exploit the forest that the natural reproduction of the best kinds in even superior quantity and quality is secured; the methods which must be employed to this end necessarily entail curtailment of present revenues, and as the new crop takes decades, nay, a century and more to grow to maturity the incentive for the short-lived individual, to curtail his present income for the sake of an income in the uncertain future is but slight. Where, as in older countries, the institution of family estates had secured stability and permanency of holdings, the interest in the future was greater and staved off the evil day of forest devastation, but even there the rapidity of change of the modern world asserts itself, and the safety of this resource in private hands has become doubtful.

The other functions of the forest, namely that which it exercises as a soilcover by preventing erosion of the soil, by regulating waterflow, changing surface drainage into subsoil drainage and thereby influencing the water-stages of rivers and its possible relation to the local climate conditions, pre-eminently renders it an object of government consideration.

The attempt to get the largest profit from his labor, which is the only incentive of private enterprise, is bound to lead to unconservative management, especially where the maintenance of favorable forest conditions from protective considerations is necessary, for here again the need of leaving valuable material for the time being, the need of curtailing present revenue for the sake of the future and for the sake of other people's interests can hardly be expected to be appreciated by the private individual.

Here the general principle of Roman law, *Utere tuo ne alterum noceas*, prevention of the obnoxious use of private property, establishes readily the propriety of state interference, and by *alterum* we are to understand not only the other citizen of the present, but of the future as well.

We see, then, that the forest resource is one that under the active competition of private enterprise is apt to deteriorate and in its deterioration to affect other conditions of material existence unfavorably; that the maintenance of continued supplies as well as of favorable conditions is possible only under the supervision of permanent institutions, with whom present profit is not the only motive. It calls preëminently for the exercise of the providential functions of the state to counteract the destructive tendencies of private exploitation. In some cases restriction of the latter may suffice; in others ownership by the state or some smaller part of the community, a permanent associated institution is necessary.

I close with the hope that the students of political economy associated with this Section will see that this branch of their science, the economy of natural resources, so important and yet so much neglected, requires on their part a fuller and more careful consideration.

B. E. FERNOW.

DEPARTMENT OF AGRICULTURE,
WASHINGTON, D. C.

CURRENT NOTES ON ANTHROPOLOGY (XII).

'CARIB ART' AND ITS SIGNIFICANCE.

WHEN Von Den Steinen went among the Carib tribes of southern Brazil he was surprised to find himself called by them a 'Carib,' until he found the word means 'a stranger' (literally 'not like us'). It is, and long has been, a term used extremely vaguely. There are tribes in Central America called Caribs, who are no more allied to the Caribbean stock than are the Iroquois. In fact, there was not a single tribe of the stock in North America anywhere at the time of the discovery.

'Carib art' has been alleged to have left its traces in Florida and in the Greater Antilles; but the curvilinear decorations, the little clay images, and the broad, rough-flaked arrow heads, asserted to be evidence of Carib work, have yet to be shown to be peculiar to that stock. In a recent pamphlet written by Mr. J. J. Quelch, curator in charge of the British Guiana Museum at Demerara, he mentions a number of such objects found on the Puruni River and the east coast, which he inclines to attribute to the Caribs, though historically they did not live in that region. Other relics were a small plate of gold, neat quartz beads, perforated, granite plates, pots and polishers and pottery with highly wrought figures of men and animals. These certainly suggest a nation to the west of the locality, but not necessarily Carib. That name should now be confined to the members of the well-marked linguistic stock

which we now know so well through the admirable studies of Von Den Steinen and Lucien Adam. It is in no wise synonymous with 'Antillean,' as some have employed it.

SYPHILIS AND LEPROSY IN ANCIENT AMERICA.

As a question in the history of disease, as well as having some archaeological bearings, the presence of syphilis and leprosy in America before the discovery has deservedly attracted the attention of investigators.

The latest contribution to the subject is by Dr. Albert S. Ashmead, in a series of articles in the *Journal of the American Medical Association*, reprinted in pamphlet form. He has had the good idea of studying the ancient pottery for representations of persons afflicted with these deforming diseases, and his results are quite remarkable. He finds in the mound pottery of the United States, and especially in the ceramics of Peru, numerous figures of persons with their faces or members marred by some erosive disease, akin to, if not identical with, those mentioned. His conclusions are that both prevailed in different parts of America in pre-Columbian times; but that the deformations represented are more likely to be lupoid or syphilitic than leprous, without, however, excluding the possibility of the latter.

He does not consider that the presence of these diseases on the American continent would necessarily point to an extra-American source. We know too little of their etiology to justify the construction of theories in that direction; but it enables us better to understand the significance of many of the specimens in our museums.

PREHISTORIC BOTANY.

THE American ethnologist, Charles Pickering, devoted the last fifteen years of his life to a vast work intended to show the early history and migrations of the human species by the distribution and cultivation

of plants. Though left incomplete, it is a storehouse of information and suggestion.

Since then, prehistoric science has taken a long stride, and that branch of it devoted to the study of the vegetation which surrounded primitive man and his early culture-plants has not been neglected. We have but to remember what a conspicuous feature it is in the mooted question of the origin of the Aryans to see the value attached to it by thoughtful students.

In America, Dr. Harshberger, of the University of Pennsylvania, has contributed a searching study to maize, and others have traced the archæologic history of tobacco, mandioca, etc. A work which has just appeared in Europe from the competent pen of Dr. George Buschan takes up the cultivated and useful plants found in the prehistoric sites of the old world, both Europe and Asia (*Vorgeschichtliche Botanik der Cultur und Nutzpflanzen der Alten Welt, auf Grund Prähistorischer Funde*, J. U. Kern, Breslau, 1895). He has prepared for it by a ten years' study of the collections in various museums and in private hands, and has received the aid of most of the eminent archæologists of Europe. His results enable the student for the first time to estimate correctly the value and meaning of much of the material collected.

D. G. BRINTON.

UNIVERSITY OF PENNSYLVANIA.

CURRENT NOTES ON PHYSIOGRAPHY (XV.).

LAKES IN THE AUSTRIAN ALPS.

AN atlas of the lakes in the Austrian Alps, prepared under the direction of Professors Penck, of the University of Vienna, and Richter, of the University of Graz, begins with a folio on the Lakes of the Salzkammergut, sounded by Simony and drawn by Mullner, and lately published by Hölzel, of Vienna. The text by Mullner will constitute a number of Penck's *Geographische Abhandlungen*, to be issued shortly. A second

number of the atlas will be by Richter, concerning the more eastern Alpine lakes. The eighteen maps now published are on a scale of 1: 25,000; the land tinted in two or three shades of buff, the water in several shades of blue. The land has contours, generally at 20-meter interval; the water has the original sounding and the conjectural contours for every ten meters. Numerous true scale sections are added.

In this connection mention may be made of the atlas of French lakes by A. Delebecque, published by the French Ministry of Public Works, 1892-93 (Paris, Baudry), with maps on scales of 1: 10,000 and 1: 20,000, for which a text is announced as forthcoming. The land surface is here left blank.

LOFTY BALLOONING IN GERMANY.

THE scientific skill of the Germans in lofty ballooning is only exceeded by the height of their ascents. The 'Cirrus,' fitted with automatic meteorological instruments and despatched without an observer, reached heights of 16,325 m. above sea level on July 7, and 18,500 m. on September 6, 1894; the minimum recorded pressures being 85 and 59 mm., and temperatures, -53° and -67° C. It is thought that these extremely low temperatures are nevertheless not so low as they should have been; the mechanical aspiration for the thermometer being regarded as insufficient. The heights are calculated with careful regard to temperature, thus making them less than the values that would be given by rough calculation, such as has been used by certain other aeronauts.

The 'Phoenix' carried Gross and Berson to a height of 7,930 m. on May 11, 1894; but this altitude was much exceeded by the ascent of Berson alone on December 4, to 9,150 m. above sea level, where the temperature was -47.9° C. Berson prepared himself for this extraordinary flight by a good

eight-hour sleep, while his associates made the balloon and the instruments ready. He carried up a steel cylinder, filled with a thousand liters of oxygen, condensed to 200 atmospheres pressure; this to reinforce his breathing at great heights. Only once was he partly overcome with sleep; then he roused himself with a loud scolding. He made a full series of observations on the way up and down; and when nearing the ground this well-trained observer packed up his instruments, so that they should not be injured in case he alighted violently. (Dr. W. Köppen, in *Annalen der Hydrographie*, 1895, May, 179-185.)

W. M. DAVIS.

HARVARD UNIVERSITY.

SCIENTIFIC NOTES AND NEWS.

THE HUXLEY MEMORIAL.

THE movement inaugurated in England, in favor of the erection of a suitable memorial to the late Professor Huxley, by Lord Kelvin, Sir John Lubbock, Professor Michael Foster and others, is taking form rapidly. In conference with Lord Kelvin, a suggestion has been made by Dr. Thurston that the monument be made international, and it is expected that, on the convening of the British committee, in October, this extension of the plan may be given formal approval and a beginning of the work affected. Every member of the original provisional committee thus far consulted is reported to be favorably disposed, and the American promoter of the plan reports from Belgium an equally favorable inclination on the part of scientific men there; and it is expected that the same disposition will be manifested in Germany and in France. Meantime, the American subscription is already headed by Mr. Carnegie with \$500 (and more, possibly, if needed), and is likely to reach a large sum. It is hoped that the American committee will be made up of leading men of science in the

United States and the contribution be thus made a noteworthy one in other than a purely financial way. Scientific men and others interested in this great movement may, meanwhile, transmit their pledges and subscriptions either to SCIENCE or to Dr. Thurston, and they will be promptly entered upon the list, as received. The Huxley memorial cannot fail of being made worthy of that famous man and of the great nations taking part in its erection.

THE FRENCH ASSOCIATION FOR THE ADVANCEMENT OF SCIENCE.

THE Association met at Bordeaux on August 4th, at which place its first meeting was held twenty-three years before. The members were welcomed by the Mayor of Bordeaux, who called attention to the progress made by the city in educational, scientific and philanthropic institutions since the previous meeting of the Association. The number of elementary schools has been tripled, and there have been established faculties of science, letters, law and medicine, attended by more than 2,000 students. M. Émile Trélat, the President, chose as the subject of his address, *La Salubrité*, in which he traced the more important contributions of hygiene to science and human welfare. M. Livon, Secretary of the Association, gave an account of the preceding meeting at Caen and reported a necrology and the honors which had been conferred during the year on members of the Association. The Treasurer, M. Émile Galante, gave an account of the finances of the Association, from which it appears that the receipts for the year were over 86,000 fr. The capital of the Association is now over 1,000,000 fr. A large number of grants varying in amount from 200 to 1,500 fr. were made for the advancement of science in various directions. The Association met in four sections: Mathematics, physical and chemical science, natural science and

economic science, before each of which many papers (some 200 in all) were presented.

being at the same time thoroughly trained in the other.

THE RELATIONS OF PHYSIOLOGICAL AND CLINICAL RESEARCH.

ONE of the most interesting addresses before the *British Medical Association* was the introductory address 'On The Relationship in which Physiological and Clinical Work Stand to One Another' with which Dr. Ferrier opened the section of physiology. According to the official report in the *British Medical Journal*, Dr. Ferrier pointed out, by taking specific examples, how largely recent progress had been affected by a thorough and accurate combination of results attained by the two methods. Thus he mentioned how experimenting on animals, and from a physiological standpoint Professor Sherrington had succeeded in mapping out a whole series of skin areas in relation to segmental regions of the spinal cord. Further, from the clinical side Dr. Head had attained great success by a thorough study of herpetic areas and areas of referred pain in showing the relationship of thoracic and abdominal viscera to spinal segments. Dr. Ferrier pointed out how great were the difficulties encountered by the clinical worker, as the cases he had to unravel were so complex and at first sight contradictory; yet in so many instances, so soon as physiological work could be brought to bear upon them, order soon appeared among the mass of facts which had been accumulated. Moreover, that working under the comparatively simple conditions produced by experiment, physiologists were in a far better position to criticise and throw light upon the obscurer facts of clinical work. To many physiological problems, however, an answer could only be finally obtained as a result of clinical study, and he therefore particularly emphasized the necessity of a worker in either branch

GENERAL.

THE second annual meeting of the Society for the Promotion of Engineering Education will be held in connection with the A. A. S. at Springfield, on September 2d, 3d and 4th. It is proposed that all papers presented before the meeting shall be tributary to the subjects announced on the program. Each paper will be limited to fifteen minutes, and an abstract of about 300 words will be printed before the meeting and distributed to the members. Five minutes will be allowed to anyone wishing to discuss the papers. There will be but one session daily for the reading of papers and for discussions.

THE question of an international bibliography of science appears to be receiving attention in all directions. An international bibliographical conference has been called to meet in Brussels, September 2-4, of this year. The programme includes the discussion of the following propositions: 1. The foundation of an international institute of bibliography. 2. The adoption of an international and universal classification of bibliography. 3. The publication of a universal bibliographical *Répertoire* by an international bureau which shall seek the cooperation of all existing bibliographical agencies. 4. Proposal to various governments to establish an international bibliographical union.

THE *Berliner Akademie der Wissenschaften* has elected as corresponding members Prof. Wilhelm V. Gümbel (Münich), Prof. Albrecht v. Zittel (Münich), Prof. Albrecht Schrauf (Vienna), Prof. Alfonso Cossa (Turin), Prof. Alexander Agassiz (Cambridge), and Prof. Eleuthère Mascart (Paris).

PROFESSOR BONNET, professor of anatomy in the University of Giessen, has received

a call to Greifswald, and Dr. M. Miyoshi has been appointed professor of botany in the University of Tokyo.

THE Paris Academy has elected Prof. Retsius and Dr. Bergh, of Copenhagen, as correspondents.

ACCORDING to the *British Medical Journal*, in the discussion on the revision of the *British Pharmacopœia*, at the annual meeting of the British Medical Association, Dr. Donald MacAlister announced on behalf of the editing committee that the metric system would be introduced into the forthcoming edition. To facilitate transition in the pharmacopœial article the official proportions will be given in the familiar British measures as well as metrically. In all gravimetric and analytical operations, however, the metric system alone will be made authoritative.

MR. W. NELSON GREENWOOD, of Glasson Dock, Lancaster, Eng., has addressed a circular letter to the shipmasters throughout Great Britain asking their opinions regarding the advisability of making a change in time reckoning. Mr. Greenwood, who publishes Tide-tables and a Nautical Almanac for the use of English seamen, is himself favorable to the unification of the civil, nautical and astronomical days.

THE papers by Mr. Borchgrevink before the *International Geographical Congress* attracted special interest. The Norwegian explorer described his voyage on the steam-whaler *Antarctic* during which he and his companions landed on Cape Adair, being the first to land on the Antarctic continent, which may be twice the size of Europe but of which we at present know nothing. The Congress unanimously passed the following resolution:

“The sixth Geographical Congress, assembled at London, 1895, with reference to the exploration of the Antarctic regions, expresses the opinion that this is the greatest

piece of geographical exploration to be undertaken, and, in view of the additions to knowledge in almost every branch of science which would result from such scientific exploration, the congress recommends that the several scientific societies throughout the world should urge, in whatever way seems to them most effective, that this work should be undertaken before the close of this century.”

MR. BINNIE, the engineer of the London County Council, has proposed a plan for a new water supply for London. It is proposed to bring the water from the valley of the Wye in two covered aqueducts, the largest in the world, the one 150, the other 176 miles in length. Each is to convey 200,000,000 gallons of water per day.

FOLLOWING the horseless carriage contest in France, one between Chicago and Milwaukee is proposed for which prizes amounting to \$5,000 are offered.

IT is stated that astronomical observations on Mont Blanc will begin soon. The Polar ‘siderostat,’ superseding the ordinary telescope, has reached Chamonix.

THE section of anatomy and histology at the recent meeting of the *British Medical Association* was of special interest, as it was the first time that a section for anatomy had been made at the meetings of the Association.

THE Indian Survey Department has sent out a scientific mission with the object of establishing a longitudinal rectification between India and Greenwich.

JOHN WILEY & Sons have published the first thousand of the fifth edition of Professor Mansfield Merriman’s ‘*Treatise on Hydraulics*,’ which has been revised and enlarged by 43 pages, and a full alphabetical index has been added.

THE *American Antiquarian* states that M. Soares has given £40,000 to the French Archeological School at Cairo.

At the recent meeting of the *International Geographical Congress* papers were

read by Professor Brückner and Mr. Frank Campbell on Geographical Bibliography, and a resolution was unanimously passed recommending that the permanent bureau should follow out the subject of geographical bibliography, and authorizing the bureau to associate with itself competent persons and give them the necessary power for prosecuting the inquiry.

DR. P. MANSEN presented a paper before the *British Medical Association* on the malaria parasite, dealing more especially with the life history of the parasite outside the human body. He showed from experiments made at his suggestion by Surgeon-Major Ross that it is probable that the intermediate host is the mosquito.

THE apparatus used at the Pasteur Institute for the discovery and treatment of bacteria and bacilli will be exhibited at the Atlanta Exposition.

BY act of the Legislature of the State of Ohio a clay-workers' school has been established at the Ohio State University, where the chemistry, mechanism and manual work of everything connected with clay industries is taught. Prof. Orton is the director of this school.

AT a recent meeting of the Board of Scientific Directors of the New York Botanic Garden it was resolved to authorize a topographical survey of the 250 acres of land in Bronx Park which have been set aside for the uses of the garden. All the trees in the park are to be labelled, and new varieties of seeds desirable for cultivation are to be secured.

MR. MARSHALL M. TIDD, a well known civil engineer, died in Woburn on August 20th, at the age of sixty-eight. Mr. Tidd was one of the oldest members of the Boston Society and the American Society of Civil Engineers.

THE Commissioner of Patents, John S. Seymour, has submitted to the Secretary of

the Interior a summary of his report for the year ending June 30th, 1895. 20,745 patents were granted during the year.

COL. HENRY L. ABBOT, of the Engineer Corps, has been placed on the retired list of the army.

THE Russian National Health Society announces that it will celebrate, in May, 1896, the one hundredth anniversary of Jenner's first experiments in vaccination. To commemorate the event the Society proposes: (1) to offer four prizes for the best works upon vaccination; (2) to collect and publish materials for a history of the practice of vaccination in Russia, and also a short history of the same in western Europe; (3) to publish a Russian translation of Jenner's works, with his biography and portrait; (4) to organize an exhibition of objects connected with vaccination; and (5) to hold a commemorative meeting on the day of the centenary.

THE French Société de Médecine Publique et d'Hygiène Professionnelle offers, according to the *Medical Record*, three prizes for the best *mémoire* on 'Preventable Diseases and the Preventive Measures to be Taken.' The first prize is 1200 fr., the second 800 fr. and the third 500 fr. The essay is not to exceed from twenty to thirty pages of 500 words each. The following points must be treated: How to prevent contagious diseases during the illness and after; private sanitation of patients and those who tend and treat them; house sanitation and disinfection, and general sanitation during illness.

One of the most interesting features of the meeting of the *British Medical Association* in the collection of medical antiquities found in Italy by Dr. Luigi Sambon and exhibited by Messrs. Oppenheimer at the Savoy Hotel. It consists of a number of surgical instruments and terra cotta models collected from ancient Roman and Etruscan

temples and tombs. The models are votive offerings (*donaria*) which used to be presented to the shrine of some deity by the common people, and their medical significance is Dr. Sambon's own discovery. Looking one day at the collection of these objects in the museum at Rome, he noticed that they were intended to represent portions of the human body, certain internal organs, and so forth, a fact which had completely escaped the eye of the lay antiquarian, who took them to represent fruits. This discovery aroused Dr. Sambon's interest, and he began to collect specimens from various places in Italy. He has now got together several hundreds, chiefly from the Temple of Maternity at Capua, the Temple of Minerva Medica in Rome, and from the Etruscan towns of Corneto, Civita Lavinia and Veii. These terra cotta figures were in some cases thankofferings, in others appeals for children, for relief from some disease or deformity, and so on. The model represents the part of the body affected—the face or part of the face, the ear, a limb, or some internal organ—and, though rough, they are fashioned with a considerable knowledge of anatomy.—*London Times*.

CORRESPONDENCE.

CONSCIOUSNESS AND EVOLUTION.

PROFESSOR BALDWIN'S article on 'Consciousness and Evolution' in the last number of this journal should be carefully read and considered. No student of evolution can ignore consciousness and its place in organic development, but clear ideas can only be obtained by serious psychological study. Thus Darwin in discussing 'sexual selection' continually passes from those secondary sexual characters which are useful to the male in conquering other males or in finding and securing the female, to those characters which are supposed to please or charm the female. He does not realize the great difference in the two problems. The former is simply a special case of 'natural selection.' The latter introduces entirely new factors. The taste in

the female which prefers certain colors in the male is no less complex than the colors preferred. So long as it is not possible to assign any useful function to the female taste, nothing whatever is gained by assuming it to be the cause of the preservation of otherwise harmful characters in the male.*

Now as I understand Darwin in this instance and Professor Cope in those of his writings that I have read, consciousness *qua* consciousness, in interaction with the physical world, is used to explain the preservation (Darwin) and even the origin (Cope) of variations. Thus Mr. Cope remarks (SCIENCE N. S., Vol. II., p. 125):

"The cause of the movements of organic beings are various. The best known are conscious states, as hunger, cold, heat and various other sensations; some of them of higher mental grade, as fear, anger, etc. Movements by the lowest animals, as that drop of jelly, the *amoeba*, appear to be the result of sensations. * * * * *. The phenomenon of heliotropism, for instance, when these simple creatures leave the dark and crowd into light places, cannot be shown to be due to chemical or physical causes only. They seek oxygen, which is more abundant where sunlight penetrates, but they have to be aware that they need it, and must have some knowledge of the fact when they get it."

Probably most psychologists would say that the causes of the movements of organic beings are physical stimuli acting on a complex physical organism. If we can never explain the movements of protozoa toward the light by chemical or physical causes, then it must be by some form of energy analogous to these. When Mr. Baldwin writes, "I agree with Mr. Cope that most race habits are due to conscious function in the first place," he probably means that the habits are due to the cerebral concomitants of consciousness, but I understand that Mr. Cope would assume consciousness in causal interaction with the physical world.

Mr. Baldwin does well to call attention to the relation of the social environment to human ev-

* I should myself take it for granted that the female likes certain traits because they are present in the male, not that the traits are present in the male because the female likes them. I venture to suggest that the bright colors and useless appendages in the male develop an accompanying alertness that more than counterbalances their drawbacks.

olution. The survival of the fittest, in the case of man, is as much a survival of fit ideas, institutions, etc., as of individuals. In man individual plasticity is required rather than inherited special traits. A realization of this would make a book such as Mr. Kidd's *Social Evolution* impossible. Mr. Kidd's major premise is that evolution takes place exclusively through severe natural selection, but, as a matter of fact, human progress also occurs through cooperative improvement in the social environment.

Professor Le Conte has contributed a very interesting address to the July number of *The Monist* in which he distinguishes social progress from organic development. He, however, regards the Lamarckian factors as essential to human progress, and does not, I think, adequately value the progress that can be made through improving the environment without regard to any organic change in the individual. Indeed I shall follow the advice of Mr. Le Conte in a recent number (Vol. I., page 188) of this journal and venture to point out what seems to me a fallacy in his argument. Mr. Le Conte writes: "Now I cannot at all accept this view [that Lamarckian factors are no factors in evolution]; I will not stop to argue it, but simply point out some logical consequences when applied to human progress; consequences which, it seems to me, are nothing less than a *reductio ad absurdum* for the view;" and he proceeds to describe the consequences, "the pitiless destruction of the weak, the sick and the helpless," against which "we instinctively revolt." But even if these practical consequences follow, one is surely not justified in arguing that facts do not exist because we would gladly have them otherwise.

J. McKEEN CATTELL.

SCIENTIFIC LITERATURE.

A Text-book of Zoögeography. By FRANK E. BEDDARD. Cambridge, 1895. (Cambridge Natural Science Manuals—biological series.)

Zoögeography treats of the geographical distribution of all animals, and in 'A Text-book of Zoögeography,' Mr. Beddard himself says: "The science is not limited to a consideration of the animals which inhabit dry land; but," he immediately adds, "this volume will only deal with *those forms*, touching incidentally upon

some of the fresh water species, whose distribution is apparently governed by the same laws as those which govern the distribution of the purely terrestrial animals" (p. 4). Inasmuch as the distribution of marine animals is determined by other factors than the distribution of terrestrial and fresh-water forms, we have some reason to complain of the too comprehensive scope of the title, but, with this caveat, we can judge the work in question on its own merits as an epitome of the geographical distribution of mammals and birds with some references to other animals.

The time-honored Scaterian 'regions' are retained, although modified by their own author long ago (1876). The subject-matter has been repeatedly discussed and need not detain us here. The reasons (often traversed) which have influenced Mr. Beddard are given by him at length (pp. 85-87). It is not untimely, however, to repeat that there is an entire want of congruity between the inland and marine faunal realms, and it may be added that while there is every gradation between marine and fresh-water types, the great bulk of fresh-water fishes, at least, has long been segregated completely from salt-water types, the Ostariophysi, including the hosts of Characini, Cyprinids, Gymnotids, Silurids and their numerous allies, having only a few descendants that have reverted to the salt waters. This great assemblage, by the way, furnishes an excellent illustration of the truth of Mr. Beddard's assertion that "the facts of distribution are constantly liable to be misunderstood through ignorance of classification," and that "a knowledge of comparative anatomy is absolutely essential to the student of distribution" (25). The several families of Ostariophysi are widely separated in European works on ichthyology and associated with forms with which they have no affinity. Such knowledge, too, would have prevented the coupling of the *Galaxiidae* and *Haplochitonidae* as 'two families of Salmonoid fishes' (171), for they really have no relationship to the Salmonoids, but represent a group confined to the fresh waters of the southern hemisphere. Another misapprehension as to relationships on account of superficial similarity disguising anatomical differences is responsible for the statement that "the chief feature of the island [Madagascar] is the pres-

ence of the American genera *Philodryas* and *Heterodon* among snakes, a fact which is remarkably paralleled by the *Centetidæ* among the *Insectivora*" (189). The Madagascar snakes are differentiated generically and belong to different groups from the American species, and the *Centetidæ* belong even to a family differing from the American forms (*Solenodontidæ*) with which they have been associated.

Mr. Beddard's work is very suggestive and leads to so many questions of interest that it is with difficulty we can circumscribe our inquiries within the limits of a review. We can only touch upon a few points of interest.

Although the only class groups systematically considered by Mr. Beddard are the mammals and birds, he has introduced a number of sections treating of the distribution of various minor groups, as the edentates, cuckoos, tortoises, lizards, crocodiles, snakes, batrachians, scorpions and earthworms. The section on the earthworms is especially valuable, as it contains the results of Mr. Beddard's most recent investigation of a group of which he has made a special study and quite lately published a monograph.

Mr. Beddard very properly remarks that "Land Mollusca would appear on many grounds to be exceedingly valuable as furnishing evidence in favour of ancient land connections" (p. 83), but then quotes Mr. Blanford in opposition. Recent mollacologists, and above all Prof. Pilsbry, have done much to correlate the data of structure and distribution. We feel inclined here to take exception to the statement re-echoing the old idea of 'the existing genera *Pupa* and *Zonites* going back to carboniferous times' (p. 85). The carboniferous species referred to those genera are certainly much like the recent species, but it must be remembered that shells having the same contours are secreted by animals quite dissimilar in anatomical features. The presumption is entirely against the generic identity of the ancient and modern forms, and *Dendropupa* (Owen, 1862) is a name proposed for the old upiform shells. Nevertheless the groups of mollusks are very long lived, and their presence in a country has a significance quite different from that of a mammal or other vertebrate. This may be well understood when we recall that almost all of the modern families of mollusks

originated before the commencement of the tertiary period, while almost none of the families of mammals came into existence until long after. The correlated fact follows that few families or even genera of mollusks are circumscribed in their distribution like so many of the vertebrates.

Mr. Beddard, in his systematic sketches of the various regions of the globe, has added lists of 'families' and 'genera' supposed to be 'peculiar to' those regions, but sometimes without sufficient reason. For example, of 'genera confined to the [Palearctic] region' (p. 89), *Anurosorex* also occurs in the oriental region (Assam), *Bos*, however restricted, in the oriental region at least; *Capra* in 'the Neilgherries and some other ranges of southern India' (p. 22), and *Perisorex*, *Cyanocitta*, *Nucifraga* and *Acanthis* are common in North America. Indeed *Cyanocitta* is exclusively North American, and must have been introduced into the present list through some mistake. The lists of the families and genera peculiar to the 'Neoartic region,' as well as to the 'Neotropical region,' require still more revision and large additions which space forbids us to undertake. In view of the fact that many peculiar South American genera have been omitted, we are rather surprised to find Tomes' almost forgotten *Hyraodon* (1863) resuscitated as a 'peculiar' genus of Neotropical marsupials (108). Tomes' genus may possibly have been based on a young *Didelphys*, although the characters assigned scarcely seem to be applicable to such; it has even been overlooked by Thomas, but in any even the name *Hyraodon* cannot be used, as it had been taken previously by Leidy for a well-known extinct genus related to the rhinoceroses.

Because animals are found between certain degrees of latitude, it does not follow that they specially affect the temperatures prevalent in the lowlands of such countries. The humming birds may be more numerous in tropical lands, but many types are confined to mountains and occur about the summits of very high ones and consequently in cold regions. Mr. Beddard says that "it upsets the current notions as to the tropical habits of the humming birds to learn that a species, *Selasphorus rufus*, breeds in Alaska" (p. 97), but the well-known facts as to the elevations where humming birds occur and as to the extension of species into the still

bleaker regions of the southern hemisphere should 'upset' any notion as to their intolerance of cold. Nor is it necessary to postulate a decreased temperature as the cause of isolation of the relics of a past dynasty. The proposition that the tapirs are 'purely tropical animals,' and that they have been isolated 'by the gradual decrease of heat in the northern hemisphere' (p. 131), is scarcely tenable in view of the fact that one of the species—*Tapirus pinchaque*—is an inhabitant of heights where the temperature is but moderate. The camelids, whose now living members are as isolated as the tapirs, are likewise capable of withstanding much cold as well as heat. Their demission from regions once inhabited by an ancestral stock must therefore have resulted from other complications than loss of heat, although that may have been one of the causes. Temperature in many cases affects animals indirectly (by means of its influence on the food supply) rather than directly.

Numerous names are used for animals for which those who follow strictly rules of priority would employ others, and probably Mr. Beddard himself would in some cases use others if he reconsidered the questions involved. Among such is *Platydaetylus facetanus*, properly known as *Tarentola mauritanica*, which we refer to in order to add that it certainly cannot be called a 'cosmopolitan Gecko' (p. 10), inasmuch as it is almost or (according to Boulenger) quite limited to the 'Mediterranean District.' In one case at least different names have been used for the same genus, as *Sennopithecus* (106) and *Presbytes* (103). In other cases wrong names have been used instead of those intended, as *Crice-tonys* (90) for *Cricetus* and *Cheropotanus* (100) in place of *Charodes* (preoccupied) or *Cheropsis*, and these might perplex some readers, as there are genera legitimately bearing the names so misused. Another error is manifest in the statement that the Central American tapirs 'were separated by the late Mr. Alston as a distinct genus *Elasmognathus*' (p. 109), that differentiation having been effected by Gill and Alston did not approve of it.

Typographical errors occur to (or possibly, slightly above) the normal extent we are accustomed to find in works in which so many names

of Greek or Latin origin are used. The following have been found in a hasty perusal, and are here noted for the benefit of readers: *Charadriæ* (8) for *Charadriidæ*, *Chærocampa* (10) for *Chærocampa*, *Jemlanica* (21) for *Jemlaica*, *Cinisternidæ* (38) for *Cinosternidæ*, *Testudinæ* (39) for *Testudinidæ*, *Pixys* (39) for *Pyxis*, *Pelomedusæ* (39) for *Pelomedusidæ*, *Chelydidæ* (39, 40) for *Chelyidæ*, *Carettochelydidæ* (39) for *Carettochelyidæ*, *Gecko-tidæ* (40) for *Geckonidæ*, *Xanthusidæ* (42) for *Xantusiidæ*, *Loxocenius* (46) for *Loxocenus*, *Dyscophidæ* (49) for *Dyscophidæ*, *Casarca* (46) for *Casarea*, *Panthalops* (89, 92) for *Pantholops*, *Ipéyan* (89) for *Impeyan*, *Autrozous* (93) for *Autrozous*, *Ocibus* (93) for *Ovibus*, *Pilohela* (94) for *Philohela*, *Cærebidæ* (107) for *Cærebidæ*, *Rhynchastidæ* (107) for *Rhamphastidæ*, *Mimocyehla* (108) for *Mimocichla*, *Apterygidæ* (113) for *Apterygidæ*, *Starnænas* (108) for *Starnænas*, *Calænas* (114) for *Calenas*, *Hoplochitonidæ* (171) for *Haplochitonidæ*, *Paretroplopis* (178) for *Paretropilus*, *agestis* (186) for *agrestis*, *Mani* (204) for *Mawi*, and *Dicæidæ* (204) for *Dicæidæ*.

Some others of new orthography perhaps have been given as corrections, as *Osteolemus* (43, 44) for *Osteolemus*, although a number that would much more bear correction are allowed to retain their original form, such as *Pediæcetes* (97) for *Pediæcetes*, and *Lynnæa* (142) for *Linnaea*. *Osteolemus* indeed is perfectly in accord with classical words, as, *g. e. ὀστεολέμης* (Aristotle), and a word frequently used by Mr. Beddard himself—osteology.

We would not be deemed to have examined the work thus criticized with a censorious mind; recent inquiries into the margin of error in various publications have led us to apply the same method to Mr. Beddard's volume, and we have been incited by a spirit of curiosity rather than of fault-finding. 'Balm' for the errors he and his printers have fallen into may be found in like failings of others (see SCIENCE for July 26, 1895). Really Mr. Beddard's work is a meritorious production and contains much that would be looked for in vain in larger works; it will, indeed, be of more use to some than a more bulky production, and we wish for it all success. If a second edition is called for, the corrections here made may help the author to perfect it.

THEO. GILL.

Lehrbuch der allgemeinen Psychologie. Von DR.

JOHANNES REHMKE, a. ö. Professor der Philosophie zu Greifswald. Hamburg and Leipzig, Verlag von Leopold Voss. 1894. Pp. 582.

The plan of this work is quite different from that of the many other treatises on psychology which are now issuing from the press. The emphasis of its author, Professor Rehmke of Greifswald, is placed throughout on the determination of the general questions which underlie psychological science rather than on the detailed investigation of psychological phenomena; and he offers his results as a guide for the cultivated reader as well as for technical students. This plan inevitably leads to the inclusion in the one volume of two subjects, the science of psychology and the philosophy of psychology, which most writers nowadays endeavor to keep separate. As a result the treatise divides into three parts, of which the first, *Das Seelenwesen*, is clearly metaphysical; the second, *Der Seelenaugenblick* (the psychology of the static moment), and the third, *Das Seelenleben*, combine scientific and philosophical investigations in a not altogether unambiguous way.

In philosophy Professor Rehmke belongs to the sharply defined group of German thinkers known as 'monists of consciousness.' In his criticism of the various views of the mind, therefore, he is very severe on all materialistic views, 'old' and 'new,' on all positivistic tendencies, and on 'neo-Spinozism,' while the current theories of the 'spiritualists' themselves find sharp treatment at his hands. His own doctrine is based on his belief in consciousness as the ultimate reality and insists, for its empirical foundation, on the presence in all consciousness, even the least developed, of the *Bewusstseins subject*, as an essential 'moment.' If this mean, 'self-consciousness,' as it seems most nearly to do, it is to be feared that Dr. Rehmke's fundamental position is vitiated by the now widely accepted conclusion that the consciousness of self or 'subject' is not present in the beginning of conscious life but comes after a period of growth. The general position, on the other hand, brings him into agreement with most psychologists of the day in regard to the question of 'unconscious' psychical states. These are vehemently rejected, and any theory which

shows the faintest tendency toward a belief in them is condemned out of hand.

In the more scientific portions of the work the same combination of individuality and agreement with received conclusions constantly manifests itself. The 'elementary sensations' of the associationists and evolutionists are denied, and in general all 'synthetic' theories of consciousness. Indefinite, undifferentiated consciousness of space is made a factor in cognition from the start, and even in developed space-perception the functions of movement and muscular consciousness are minimized in favor of vision. Feelings are reduced to simple pleasure and pain, which, however, are as rememberable as perceptions themselves; while the burning questions of the day in regard to the nature of emotions seem entirely unconsidered. As against Brentano and Münsterberg the actuality of will is strenuously maintained, but in the restricted sense of 'causal consciousness,' which is further interpreted as belonging to the 'Seelenaugenblick' and so independent of all concrete action, present or represented.

As a whole, therefore, Professor Rehmke's *Lehrbuch* is interesting but not satisfactory. Unquestionably psychology to-day, even psychology as science, is suffering from the lack of settled fundamental ideas and principles. But it is very questionable whether these can best be discussed in so close conjunction with the attempted explanation of the phenomena of concrete psychical life. And the endeavor to give a complete consideration of both in a single volume is, as things are now, hopeless from the start.

A. C. ARMSTRONG, JR.

WESLEYAN UNIVERSITY.

Paleontology of Missouri. By CHARLES R. KEYES, State Geologist. Missouri Geological Survey, Vols. iv. and v., 314 and 320 pages, 56 plates and a geological map of the State. Jefferson City. 1895.

This review of the fossils of Missouri is a radical departure from the reports which are usually made on the subject of paleontology. It is an attempt to make this subject as economic as possible in its bearing. Instead of giving new names to an endless number of forms, accompanied by long technical descriptions, it has

been the aim to avoid them so far as possible. The 'new species' described are scarcely more than a dozen in number. Particular attention is called to the economic value of fossils, a fact which is so commonly overlooked. A successful attempt has been made to present the ancient organisms in their proper light, and it is quite manifest that the emphasis placed on this side of the question has been none too great. In reality the fossils are regarded as labels to the rocks containing them, telling the observer at a glance the age of the beds being worked and providing a most reliable guide in directing the miner and prospector to the layers most likely to contain the minerals sought.

It is stated that the report is the outcome of a widespread desire which has existed for many years among the more enlightened class of citizens who are interested directly in advancing the mineral development of the State. The demand for accurate accounts of the organic remains found in the rocks of the region is shown to have become more and more urgent in the light of the fact that the fossils have such a distinct practical importance. In the attempt to satisfy properly the calls arising in connection with the work, it has been the aim of the author to present as briefly as possible: (1) an index to the fossils of the State, through means of which forms now known to occur within the limits of the region considered may be recognized rapidly without recourse to great libraries; (2) a list of works pertaining to Missouri fossils, in which has been brought together all that has been written on the subject and that is now widely scattered and almost inaccessible; (3) a concise summary of all that has been done up to the present time in this branch of science, so far as it pertains to the State; (4) knowledge to more comprehensive study involving the solution of problems now more or less obscure concerning the arrangement and relations of the various strata. In short, it is a handbook of the fossils of the State adapted to the use of the teacher, student and layman alike.

The general plan of treatment of the different species enumerated has been to give under each a more or less complete bibliography, by reference to which additional information or good illustrations of the forms not here figured may

be found. In the diagnoses the author has endeavored to give a rather full description of some leading representative of each genus, accompanied by a suitable figure, and to make the sketches of the other members of the genus brief and in a great measure comparative. In this way of dealing with the subject it is thought that the characterizations of all the species will be sufficiently ample for intelligent comprehension and for the particular uses to which the work will be put. At the same time the bulk of the report is greatly reduced—to one-fourth at least of what it otherwise would have been. The matter of localization is necessarily rather general, allusion being made to the nearest post office usually, or in a few instances, when the fossil is common and the distribution wide, merely to the county. As a further help there has been appended a stratigraphical catalogue, which is intended for ready reference, and a synonymic index list of all the names applied to Missouri species.

The chief characteristics of this report, as enumerated above, show that in many particulars it is radically different from the usual reports on paleontology prepared by the various State Geological Surveys. That it will be of much practical value to the citizens of Missouri is certain. On the other hand, the report gives a sufficiently complete scientific account of what is at present known concerning the fossil organisms of the State, and opens the way for future work of a more detailed and exhaustive nature.

U. S. GRANT.

GEOL. AND NAT. HIST. SURV. OF MINN.

NEW BOOKS.

A Hand-book for Surveyors. MANSFIELD MERRIMAN and JOHN P. BROOKS. New York, John Wiley & Sons. 1895. Pp. 196.

Die Vertheilung der Erdmagnetischenkraft in Österreich-Ungarn. Von J. LITZNER. 1st Part. Wien. 1895. Pp. 232.

Annual Report of the Pennsylvania State College for 1894. Clarence M. Busch, State Printer. 1895. Pp. 375.

A Working Manual of American History. WILLIAM H. MACE. Syracuse, N. Y., C. W. Bardeen. 1895. Pp. 297.

SCIENCE

NEW SERIES.
VOL. II. No. 36.

FRIDAY, SEPTEMBER 6, 1895.

SINGLE COPIES, 15 CTS.
ANNUAL SUBSCRIPTION, \$5.00.

GUSTAV E. STECHERT'S

Recent Importation of Scientific Books.

BECKERT, TH. and DR. ALBANO BRAND. Hüttenkunde. Mit 235 in den Text gedruckten Figuren. 765 Seiten. gr. 8°. Mk. 20.

BEHRENS, H. Anleitung zur mikrochemischen Analyse. Mit einem Vorwort von Prof. S. Hoogewerf in Delft. 224 Seiten mit 92 Figuren in Text. 8°. Mk. 6.

BIEDERMANN, W. Elektrophysiologie. 1^{te} Abtheilung. Mit 136 Abbildungen. 440 Seiten. 8°. Mk. 9.

BORCHERS, DR. W. Elektro-Metallurgie. Die Gewinnung der Metalle unter Vermittlung des elektrischen Stromes. 2^{te} verm. v. völlig umgearb. Auflage. 1^{ste} Abtheilung, mit 87 Abbildungen. 160 Seiten. gr. 8°. Mk. 6⁰⁰.

BUSCHAN, GEORG. Vorgeschichtliche Botanik der Cultur-u. Nutzpflanzen der alten Welt auf Grund prähistorischer Funde. 268 Seiten. 8°. Mk. 7⁰⁰.

DAMMER, DR. O. Handbuch der chemischen Technologie. Unter Mitwirkung von Direktor Th. Beckert, Dr. Bender, Dr. Benedikt, Dr. Börstein u. A. herausgegeben. 2^{ter} Band. Mit 235 in den Text gedruckten Figuren. gr. 8°. Mk. 20.

DELAGE, YVES. La structure du protoplasma et les théories sur l'hérédité et les grands problèmes de la biologie générale. 878 pages. gr. 8° cloth. frs 24⁰⁰.

DETMER, DR. W. Das pflanzenphysiologische Praktikum. Anleitung zu pflanzenphysiolog. Untersuchungen für Studierende u. Lehrer der Naturwissenschaften, sowie der Medicin, etc. 2^{te} völlig neubearbeitete Aufl. Mit 184 Abbildungen. 456 Seiten. 8°. Mk. 9.

FOREL, DR. AUGUST. Der Hypnotismus, seine psycho-physiologische medicinische, strafrechtliche Bedeutung und seine Handhabung. 3^{te} verb. Aufl. mit Adnotationen von Dr. O. Vogt. 223 Seiten. gr. 8°. Mk. 5.

FRANK, DR. A. B. Die Krankheiten der Pflanzen. Ein Handbuch für Land u. Forstwirthe, Botaniker, etc. Erster Band, Die durch anorgan. Einflüsse hervorgerufenen Krankheiten. Mit 34 Holzschnitten. 2^{te} Aufl. 344 Seiten. 8°. Mk. 6⁰⁰.

HIS, WILH. Die anatomische Nomenclatur. Nomina anatomica, Verzeichniß der von der anatomischen Gesellschaft auf ihrer 9. Versammlung in Basel angenommenen Namen. Mit 30 Abbildgn. im Text und 2 Tafeln. 180 Seiten. Mk. 7⁰⁰.

HOUDAILLE, F. Météorologie agricole. 204 pages cloth. fr. 3.

JAHRBUCH DER ELEKTROCHEMIE. Berichte über die Fortschritte des Jahres 1894. Im wissenschaftlichen Theile bearbeitet von Dr. W. Nernst. Im technischen Theile bearbeitet von Dr. W. Borchers. 1^r Jahrgang. 274 Seiten. gr. 8°. Mk. 10.

JERUSALEM, WILH. Die Urtheilsfunction. Eine psychologische und erkenntnistheoretische Untersuchung. 269 Seiten. Mk. 6⁰⁰.

LOEWY, DR. A. Untersuchungen über die Respiration und Circulation bei Aenderung des Druckes und des Sauerstoffgehaltes der Luft. Mit 5 Curventafeln im Text. 155 Seiten. gr. 8°. Mk. 4.

MEYER, DR. ARTH. Untersuchungen über die Stärkekörner der höheren Pflanzen. Mit 9 Tafeln u. 99 Text-Abbildgn. 318 Seiten. gr. 8°. Mk. 20⁰⁰.

NIEDENZU, DR. FRANZ. Handbuch für botanische Bestimmungsübungen. Mit 15 Figuren im Text. 351 Seiten. 8°. Mk. 4.

SCHAFFER, DR. KARL. Suggestion und Reflex. Eine Kritisch-experimentelle Studie über die Reflexphänomene des Hypnotismus. Mit 6 Tafeln in Lichtdruck und 11 Abbildungen im Text. 113 Seiten. gr. 8°. Mk. 6⁵⁰.

SCHMIDT, DR. ALEX. Weitere Beiträge zur Blutlehre. Nach des Verfassers Tode herausgegeben. 247 Seiten. 8°. Mk. 7.

SCHWARTZ, TH. Die Lehre von der Electricität und deren praktische Verwendung. Mit 153 in den Text gedruckten Abbildungen. 543 Seiten. 8°. Mk. 10⁰⁰.

STEINHARDT, DR. EUGEN. Kurzes Lehrbuch der Chemie zum Gebrauch an Schulen und zur Selbstbelehrung. Zwei Theile. Erst. Teil; Anorganische Chemie. 418 Seiten. 8°. Mk. 6⁰⁰.

VAN BIERVLIET, J. J. Elements de psychologie humaine. Cours professé a l'université de Gand. Avec 34 figures dans le Text. 317 pages. frs. 8.

ZEITSCHRIFT FÜR ANGEWANDTE MIKROSKOPIE herausgegeben von G. Marpmann. Monthly. 1^{er} Band 1^{er} Heft. Per year, \$2.75.

ZEITSCHRIFT, Geographische, Herausgegeben von Dr. Alfred Hettner. 1^{er} Jahrg. 1^{er} Heft. Per year (12 N^{os}) \$4⁰⁰.

ZIMMERMANN, DR. A. Das Mikroskop. Ein Leitfaden der wissenschaftlichen Mikroskopie. Mit 231 Figuren im Text. 334 Seiten. gr. 8°. Mk. 9.

ZITTEL, KARL A. VON. Grundzüge der Paläontologie (Paläozoologie). Mit 2048 in den Text gedruckten Abbildungen. 971 Seiten. gr. 8°. $\frac{1}{2}$ mor. Mk. 25⁰⁰.

GUSTAV E. STECHERT,

810 Broadway, New York.

Macmillan & Co.'s New Publications

NEW VOLUME OF THE

Columbia University Biological Series.

Edited by HENRY FAIRFIELD OSBORN, *Da Costa Professor of Biology in Columbia College.*

Fishes, Living and Fossil.

An Outline of their Form and Probable Relationship.

By BASHFORD DEAN, Ph. D. Columbia, *Instructor in Biology, Columbia College.*
With Illustrations from the Author's original Pen Drawings. 8vo, cloth, \$2.50 net.

ALREADY PUBLISHED IN THE SAME SERIES.

From the Greeks to Darwin. The development of the evolution idea. By HENRY FAIRFIELD OSBORN, Sc. D. Princeton, *Da Costa Professor of Biology in Columbia College.* 8vo, cloth, \$2.00 net.

Amphioxus and Ancestry of the Vertebrates. By ARTHUR WILLEY, B. Sc. Lond., *Tutor in Biology, Columbia College, Balfour Student of the University of Cambridge.* With Illustrations. 8vo, cloth, \$2.50 net.

NEW VOLUME.

Columbia University Press.

Atlas of the Fertilization and Karyokinesis of the Ovum.

By EDMUND B. WILSON, Ph. D., *Professor of Invertebrate Zoology in Columbia College*, with the cooperation of EDWARD LEAMING, M. D., F. R. P. S., *Instructor in Photography at the College of Physicians and Surgeons, Columbia College.* Illustrated with 40 figures photographed from nature by Dr. Leaming, from the preparations of Professor Wilson at an enlargement of one thousand diameters, and mechanically reproduced by the gelatine process without retouching, by Edward Bierstadt of New York. The plates are accompanied by an explanatory text, giving a general introduction to the subject for the use of students and general readers, a detailed description of the photographs, and over sixty text-figures from camera-drawings. 8vo, cloth, \$4.00 net.

Hertwig.—The Cell: Outlines of General Anatomy and Physiology. By DR. OSCAR HERTWIG, Professor Extraordinarius of Anatomy and Comparative Anatomy, Berlin. Translated by M. CAMPBELL and Edited by HENRY JOHNSTONE CAMPBELL, M. D., Assistant Physician to the City of London Hospital for the Diseases of the Chest, etc. With 168 Illustrations. 8vo, cloth, pp., \$3.00, net.

Lindsay.—An Introduction to the Study of Zoology. By B. LINDSAY, C. S. of Girton College, Cambridge. With 124 Illustrations and Diagrams. Pp. xix+356, 12mo, cloth, \$1.60 net.

Cooke, Shipley and Reed. Molluscs and Brachiopods. By REV. A. H. COOKE, M. A., Fellow of King's College, Cambridge; A. E. SHIPLEY, M. A., Fellow of Christ's College, Cambridge; and F. R. C. REED, B. A., Trinity College, Cambridge. Illustrated. *Cambridge Natural History.* 8vo, cloth, pp. 535, \$3.25 net.

"Written in the true spirit of the *Alpine Climber.*"

The Alps from End to End. By SIR WILLIAM MARTIN CONWAY. With 100 Illustrations by A. D. McCORMICK. Large demy, 8vo, cloth, \$7.00.

The Rural Science Series.

Edited by L. H. BAILEY. New Volume.

King.—The Soil. Its Nature, Relations and Fundamental Principles of Management. By F. H. KING, Professor of Agricultural Physics in the University of Wisconsin. 16mo, cloth, 75 cents.

Jackson.—The Great Frozen Land. Narratives of a Winter Journey across the Tundras and a Sojourn among the Samoyads. By GEORGE F. JACKSON, Fellow of the Royal Geographical Society and Leader of the Jackson-Harmsworth Polar Expedition. With Illustrations and Maps. Edited from his Journals by ARTHUR MONTFLORE. 8vo, cloth, pp. xviii+297, \$4.50.

Wright.—Birdcraft. A Field Book of Two Hundred Song, Game and Water Birds. By MABEL OSGOOD WRIGHT. With numerous full-page Plates containing 128 Birds in the Natural Colors, and other Illustrations. 8vo, bound in linen, \$3.00 net.

"An Arctic Adventure."

Ice-Bound on Kolguev. By AUBYN TREVOR-BATTYE, F. L. S., F. Z. S., etc. With numerous Illustrations and Drawings, and 3 Maps. Large 8vo, cloth, gilt top, \$7.00.

MACMILLAN & CO., 66 Fifth Avenue, New York.

SCIENCE

EDITORIAL COMMITTEE: S. NEWCOMB, Mathematics; R. S. WOODWARD, Mechanics; E. C. PICKERING, Astronomy; T. C. MENDENHALL, Physics; R. H. THURSTON, Engineering; IRA REMSEN, Chemistry; J. LE CONTE, Geology; W. M. DAVIS, Physiography; O. C. MARSH, Paleontology; W. K. BROOKS, Invertebrate Zoology; C. HART MERRIAM, Vertebrate Zoology; S. H. SCUDDER, Entomology; N. L. BRITTON, Botany; HENRY F. OSBORN, General Biology; H. P. BOWDITCH, Physiology; J. S. BILLINGS, Hygiene; J. MCKEEN CATTELL, Psychology; DANIEL G. BRINTON, J. W. POWELL, Anthropology.

FRIDAY, SEPTEMBER 6, 1895.

CONTENTS:

| | |
|--|-----|
| <i>Seventh Summer Meeting of the Geological Society of America</i> : J. F. KEMP..... | 277 |
| <i>The Relations of the Industries to the Advancement of Chemical Science</i> : WILLIAM McMURRIE..... | 283 |
| <i>American Microscopical Society</i> | 296 |
| <i>Engineering Notes</i> :—..... | 298 |
| <i>The British Institute of Mechanical Engineers; The Congress of Sanitary Engineers and Architects; General</i> : R. H. THURSTON. | |
| <i>Scientific Notes and News</i> | 299 |
| <i>University and Educational News</i> | 301 |
| <i>Correspondence</i> :—..... | 303 |
| <i>The Nature of Vowels</i> : WESLEY MILLS. The 'Date of Publication' in the Light of the Law of Priority: HERBERT HAVILAND FIELD. <i>Electric Storm on Mount Elbert, Colorado</i> : P. A. WELKER. | |
| <i>Scientific Literature</i> :—..... | 306 |
| <i>Gage's Principles of Physics</i> : W. LE CONTE STEVENS. <i>Engel's Theorie der Parallelinien von Euclid bis auf Gauss</i> : GEORGE BRUCE HALSTED. <i>Boas' Chinook Texts, Nicolai's Life and Traditions of the Red Man</i> : A. S. G. <i>Dennert's Vergleichende Pflanzenmorphologie</i> : JOHN W. HARSHBERGER. | |
| <i>Scientific Journals</i> :—..... | 312 |
| <i>The Botanical Gazette; Psyche</i> . | |
| <i>New Books</i> | 312 |

MSS. intended for publication and books, etc., intended for review should be sent to the responsible editor, Prof. J. McKeen Cattell, Garrison on Hudson, N. Y.
Subscriptions and advertisements should be sent to SCIENCE, 41 N. Queen St., Lancaster, Pa., or 41 East 49th St., New York.

SEVENTH SUMMER MEETING OF THE GEOLOGICAL SOCIETY OF AMERICA.

THE seventh summer meeting of the Geological Society of America convened in Springfield, Mass., August 27th and 28th, 1895. The Council assembled the evening before, prepared the program of

the meeting and formulated such other business as was necessary to present to the Society the following day. The fellows and their friends to the number of thirty-five assembled in the new City Art Museum at 10 A. M., August 27th. The meeting was called to order by President Shaler, who introduced Dr. William Rice, Secretary of the Library Association of Springfield. Dr. Rice welcomed the Society in a few happily chosen remarks, from which the Society learned that they were the first organization to occupy the building. President Shaler replied to the address. Brief memorial mention was made of Professor Henry B. Nason, of Troy, and Professor James D. Dana, of New Haven, the two fellows who had passed away since the last meeting.* Extended memorials were, however, postponed to the winter meeting, according to the usual custom. The Secretary announced the election of the following fellows: S. P. Baldwin, Cleveland; O. C. Farrington, Chicago; G. P. Grimsley, Topeka, Kansas; F. P. Gulliver, Norwich, Connecticut; J. B. Hatcher, Princeton, New Jersey; E. B. Matthews, Baltimore; J. C. Merriam, Berkeley, California; H. B. C. Nitze, Baltimore; F. L. Ransome, Berkeley, California; Charles Schuchert, Washington, D. C.; J. A. Taff, Washington, D. C. The report of the committee on the preparation of a card catalogue of scientific literature, which was printed in the

proceedings of the Baltimore meeting, but which had been laid on the table pending amendment, was recalled and passed unanimously. The committee (Emmons and Willis), appointed at the Madison meeting, 1893, to urge on the United States Senate the importance of making the region about Mt. Rainier a public park, reported that they and others had presented the case to the Senate Committee having it in charge, but that the bill had failed of recommendation. On motion the committee was continued, and President Shaler was added to it. Before proceeding to the reading of papers the usual rule was adopted, that papers not presented by their authors in person should go to the end of the list. The first paper read was 'The Champlain Glacial Epoch,' by C. H. Hitchcock, Hanover, N. H. The author stated that when he gave the name Champlain to the clays and sands along this lake, he was a disciple of Lyell, and believed in submergence and iceberg action, but wider experience had made him a follower of Agassiz, and in that he now favored a moderate submergence with local glaciers coming down from the mountains to the east and west, but with an oceanic connection, certainly out through the Gulf of St. Lawrence and probably to the Hudson and westward. He mentioned the species of shells found in the clays of the St. Lawrence Valley, and along the Atlantic near Portland, Maine, and proved them to be of a Labradorian facies. On citing the European divisions of the Glacial Age of James Geikie, the speaker surmised that the Champlain epoch corresponded to the Mecklenbergian.

The paper led to a somewhat extended discussion. I. C. White raised the question of the connection between the submergence and the terraces of the river valleys in the Alleghenies in West Virginia and Pennsylvania, and the lack of fossils. J. F. Kemp cited the barrenness of the clays in the

Hudson Valley in all organic remains except a few diatoms, and that the variety was small in the Champlain valley itself. J. W. Spencer remarked the moderate elevation of the Laurentide Mountains so-called and other topographical features of the St. Lawrence Valley. W. M. Davis brought up the importance of properly distinguishing terraces in work of this kind, especially as between marine and re-cut river deposits in valleys. The discussion then drifted to the meaning of Champlain, as to whether it applied to a time division or a series of sediments, and was closed by the president, who suggested that the lack of fossils might be caused by the decay of organic matter in the clays, which would develop gases and destroy them.

The second paper was by H. L. Fairchild, of Rochester, N. Y., and was entitled 'The Glacial Genesee Lakes.' By means of an admirable map, the valley of the Genesee River was shown and the relations of its drainage basin to surrounding river systems. The heights of the divides were marked from the headwaters in Pennsylvania down to Rochester. The argument was then made that the ice-sheet came from the north and filled the valley, all of whose streams were pre-glacial and had flowed in almost all cases near their present channels. Then as the ice retreated the waters at its front and from neighboring heights were ponded back and were drained off to the south, west and east, sometimes to the Allegheny River system, sometimes to the Susquehanna. The old channels are now largely represented by cols with swamps at the divides. Ten stages were recognized in all, viz.: 1. The headwater cols over 2,000 ft. A. T. south of Genesee, Pa. 2. The col at the head of the west branch near Genesee, Pa. 3. At Mapes, N. Y., col, 1606 A. T. 4. Head of Olean Creek, col 1490. 5. The cut from Portage to the headwaters of the Susquehanna. 6. Col at Hor-

nellsville, 1200 A. T. 7. A broad stream to westward over flat country north of Portage. 8. Warren Water. 9. Lake Iroquois. 10. Present relations. The speaker also described the terraces, bisected deltas and other surface deposits that corresponded to the several cols, and remarked that there were but four places where the present streams were working on rock.

I. C. White asked if the old burned channels around these rock cuts were known, but the speaker replied that there was too much drift and too few borings. President Shaler argued that the cols of the first stage were due to subglacial streams. J. W. Spencer, W. M. Davis and H. S. Williams brought up minor points, after which adjournment was made for lunch.

The Society met at 2 and listened to an extended paper by Professor B. K. Emerson, of Amherst, on 'The Geology of Hampshire, Hampden and Franklin Counties, Mass.' These are the three counties along the Connecticut river in Massachusetts. They embrace Archean crystalline rocks, metamorphosed Cambrian and Devonian sediments, Triassic sandstones and traps, Glacial deposits and Champlain clays. The speaker illustrated his remarks by large maps, the results of nearly twenty-five years of study. His address was divided into three heads. He first took up the Archean and paleozoic rocks. The former are in the continuation of the Green Mountains and lie on the west side of the valley. Among other things they embrace a great belt of granite containing inclusions of marble, and a great belt of hornblende schist on which rests the emery bed at Chester. On the older crystallines lies unconformably the Cambrian conglomerate now metamorphosed to gneiss, and the same appears at Monson on the east, where it is quarried as granite. The Devonian beds appear at Bernardston and exhibit remarkable contact metamorphism. The second part of

the paper dealt with the Triassic sandstones and traps. The dikes, plugs, tufts, and the faults characteristic of this series were described. The third part of the paper discussed the glacial deposits, Champlain clays and the variations in the channel of the Connecticut river in the formation of oxbows.

The address was the most important of the meeting and was listened to with close attention by all present.

The next paper was by W. B. Clark, of Baltimore, 'On the Eocene Fauna of the Middle Atlantic Slope.' The speaker reviewed our previous knowledge of the forms of life of this period and detailed the great increase in the number of species and in the sharpness of their determination that had resulted from the explorations of the last few years. The faunas were now so well understood and established as to be of great stratigraphic value. The paper was followed by R. T. Jackson and T. A. Jaggard, of Cambridge, Mass., on the 'Arrangement and Development of Plates in the Melonitidæ.' The anatomical structure and life history of this group of echinoderms were described. The next paper was by Wm. H. Hobbs, Madison, Wis., 'Pre-Cambrian Volcanoes in Southern Wisconsin.' The speaker presented a preliminary report on the study of a group of isolated areas of igneous rocks which protrude through the Potsdam sandstone in the valley of the Fox river, Wisconsin. Some of these areas represent local outflows of rhyolitic lava which exhibits superb examples of spherulitic, perlitic, fluxion and breccia structures. The originally glassy ground mass of these rocks has become devitrified; hence they are apo-rhyolites, and they have been subjected to dynamic metamorphism and subsequent infiltration of silica. They are intruded by dikes of both basic and acid rocks. Specimens and photographs of sections were exhibited.

The succeeding speaker was A. Capen Gill, of Ithaca, N. Y., on 'A Geological Sketch of the Sierra Tlayacac, in the State of Morelos, Mexico. The Sierra Tlayacac, situated to the southward of the great fault-line described by Felix and Lenk, consists of a projecting group of mountain tops in the midst of the Morelos Plain. The plain is formed by the lava streams and ejectamenta of Popocatepetl or neighboring volcanic vents. The tops of the nearly submerged mountains show that the folding and elevation of the Cretaceous (Caprina?) limestone was accompanied or followed by the deposition of a limestone conglomerate, in the pebbles of which are also Caprina (?) fossils. Lack of eruptive pebbles indicates that the volcanic activity of the region was subsequent to extensive folding and erosion.

The limestone conglomerate is overlain by an acid eruptive, and both rocks are cut by numerous dykes which show a close 'consanguinity' with the recent extrusions of Popocatepetl. The very striking metamorphism produced by these dykes corroborates the view that there is little, if any, migration of material from the intruded mass into the metamorphosed rock.

Heated water and steam would appear to be the principal agents of metamorphism, rather than heat alone, since the great distance to which recrystallization has reached seems dependent on the *porous character* of the rock before alteration.

Garnet, vesuvianite, wollastonite and pyroxene are among the minerals developed, and large crystals have been found at a distance of several hundred feet from the contact.

Considerable discussion followed in which the forbearance of the author in refraining from the creation of new rock-names, was heartily commended.

The session then adjourned until 9 A. M. of Wednesday. On reassembling the following morning the first paper was pre-

sented by W. M. Davis, Cambridge, Mass., on 'The Bearing of Physiography on Uniformitarianism.'

The conditions and processes postulated in the physiographic study of land forms—geomorphology of some authors—are among the cardinal principles of uniformitarianism. The success in the interpretation of nature by means of this kind of study confirms the correctness of its postulates, and thus brings to the support of uniformitarianism a large class of facts, whose bearing on this theory was not at all perceived when its early advocates announced it. These general principles were further elucidated by the example of the development of the river Marne in northeastern France, and of its associated streams. The migration of divides and the robbing of one stream by another in the course of slow degradation were traced out as an illustration of large effects from the operation of slow and gradual causes. In discussion B. K. Emerson cited similar cases of the robbing of one stream's headwaters by another, in the relations of the Housatonic and Connecticut divides in western Massachusetts. President Shaler emphasized the importance of continental tilting in bringing about these changes of drainage, and illustrated his point by cases in the Berkshire Hills.

C. R. Van Hise, of Madison, Wis., followed with a paper on the 'Analysis of Folds.' As regular movement three zones in the constitution of the earth were cited, an outer of fracture, an inner of fracture and flowage, and an interior one of flowage alone. The particular depth or extent of each depends on the hardness or softness of the strata; shales, for instance, flow at a small depth. The subject of folds was then taken up, and it was shown that the ordinary treatment of the subject with sections in only two dimensions was incomplete in that it failed to properly emphasize the pitch of the axes and the presence of other

folds at angles with the first series. The relations of various smaller wanes as all parts of one great one were also brought out, and especially the association of minor overthrown anticlines with a central fan-shaped fold. The former incline toward the latter in case of fan-shaped synclines and away from it in corresponding anticlines. The paper closed with practical suggestions in taking and interpreting observations, but feeling pressed for time, the speaker passed over them with such rapidity that an appreciation of them will require the printed text. W. M. Davis in discussion referred to the three zones originally cited and asked if the speaker could estimate from the character of the flowing or fracture, shown by an eroded fold, anything about the original burden of rock that had been removed. Prof. Van Hise in reply stated that he thought it could be done within reasonably wide limits, say two to five thousand feet.

The following paper was by N. S. Shaler, of Cambridge, Mass., and was entitled 'On the Effects of the Expulsion of Gases from the Interior of the Earth.' The smaller cases of gases emerging from muddy river bottoms, lakes and swamps were first treated, and then the larger manifestations of the same at times of earthquakes, such as those at New Madrid and Charleston. The action was likened to the succession of bubbles in champagne or soda water. One getting started eases up the weight of the overlying column of water, so that many others follow in the same path. The lack of fossils or organic remains in mud and clay where they must have originally been abundant was explained by the dissolving action of these gases, especially while in solution. The explosion of vapors in volcanic conduits was then taken up, illustrated by the speaker's observations on Vesuvius and explained in the same way as the simpler cases.

Arthur Hollick, of New York, next pre-

sented a paper on 'Cretaceous Plants from Martha's Vineyard.' Results were obtained from an examination of the material collected by David White in 1889.

At the New York meeting of the Society in December, 1889, Mr. David White read a paper entitled 'Cretaceous Plants from Martha's Vineyard,' which was published in abstract in the proceedings of that meeting. The author subsequently published a more extended account in the *American Journal of Science* for February, 1890, and figured a few of the specimens which were most readily to be identified as cretaceous species. These papers were based upon material collected by the author and Mr. Lester F. Ward during the summer of 1889. The object of these papers was principally to demonstrate the occurrence of cretaceous strata in that island, hence only sufficient material for that purpose was utilized. During the present year all the material which was collected was turned over to him for examination and report, in addition to which there were a few specimens collected personally during the summer of 1893. The general results obtained indicated a flora parallel with that of the Amboy clays of New Jersey, but as the fossil leaves are found in concretionary sandstones which are mixed with the clays in somewhat uncertain relations, it is very desirable to obtain, if possible, remains in the clays themselves. The difficulty in preserving such as have hitherto been noted has prevented their study.

J. F. Kemp, of New York, then read a contribution on 'The Titaniferous Iron Ores of the Adirondacks.' The paper opened with a brief statement of the characters of the two kinds of iron ores which are afforded by the region, the merchantable magnetites and the titaniferous. The former are in gneisses; the latter in the gabbros and anorthosites of the Norian, which are believed to be intruded through the gneisses.

A list of localities of the titaniferous ores was given and the distinction was made between the smaller bodies which are, so far as can be seen, basic developments of gabbro, and the enormous ore bodies at the old Adirondack Iron Works, in the heart of the mountains. These latter are in massive anorthosite, which is almost entirely formed of large, blue-black crystals of labradorite. The ore bodies, and especially the one crossing Lake Sanford, contain numerous included labradorite crystals, each of which is surrounded by a reaction rim 5-10 mm. across. It was further shown that the wall rocks show no signs of the widespread crushing that is exhibited in the general 'mortar-structure' of the Adirondack and Canadian anorthosites, but are plutonic rocks free from evidences of dynamic metamorphism. The argument is then made that the ores are segregations from an igneous magma formed during the process of cooling and crystallization. In conclusion the speaker gave some notes on recent attempts to utilize these ores that bid fair to be successful.

In discussion, C. R. Van Hise mentioned the similar bodies of titaniferous ores in the gabbros of Lake Superior, adding, however, that there had been some infiltration of iron oxide since the formation.

The last paper of the meeting was presented by J. C. Branner, of Stanford University, California, on 'The Decomposition of Rocks in Brazil.'

The decomposition of rocks is much more profound in Brazil than in temperate regions. This decay has lately been demonstrated by railway cuts and tunnels and by deep mines, records of which was given. This decomposition is produced by mechanical and chemical agencies.

The chief mechanical agency is daily change of temperature suffered by rocks openly exposed to the sun—about 100 degrees Far. This causes exfoliation of moun-

tain masses and of boulders and open crevices that admit water, air, insects, and these set up a train of reactions that soon destroy the rock. Chemical agencies are organic and inorganic. The inorganic agencies are carbonic and nitric acid brought down in rains in great quantities. The organic chemical agencies are insects and plants. The ground is then filled with vast hordes of ants whose breath and food form acids that attack the rocks. The rapid decay of a very rank vegetation contributes the chief agent of rock decomposition. Rain falling on hot rocks greatly increases the action of these agents. The paper was illustrated by sketches and photographs and excited the deepest interest.

On account of the absence of the authors and the need of adjournment in view of an excursion that was offered by Professor Emerson to Mt. Holyoke in the afternoon, the following papers were only read or announced by title:

George M. Dawson and R. G. McConnell: 'On the Glacial Deposits of Southwestern Alberta,' in the vicinity of the Rocky Mountains. Warren Upham: 'Drumlins and Marginal Moraines of Ice-sheets.' N. H. Darton: 'Notes on Relations of Lower Members of Coastal Plain Series in South Carolina.' N. H. Darton: 'Resumé of General Stratigraphic Relations in the Atlantic Coastal Plain from New Jersey to South Carolina.' George P. Merrill: 'On Asbestos and Asbestiform Minerals.' C. A. Gordon: 'Syenite-Gneiss (Leopard Rock) from the Apatite Region of Ottawa County, Canada.'

The regular meeting adjourned after passing a vote of thanks to the Library Association of Springfield, and to the Local Committee.

In the afternoon thirty-seven fellows accompanied Professor Emerson to Mt. Holyoke to see the contacts of trap and sandstone, the dikes, plugs, bird-track and other

phenomena of the Triassic. Before the meeting a more extended trip was taken by a good sized company. Professor Wm. H. Hobbs guided them through the interesting metamorphic region of the Berkshire Hills. They were met at Pittsfield by Professor Emerson, who took them to Chester, Bernardston, Turner's Falls, and other points of interest in the Connecticut Valley.

On the whole the meeting was an interesting and well attended one, but, as in previous summers, the fellows of the Geological Society to a very great extent returned to their homes on its conclusion. The meetings of Section E of the American Association are thereby crippled, and the question was raised in the minds of not a few, who have the interests of Section E likewise at heart, whether it is on the whole wise for the Geological Society to hold other than a business meeting, in the summer, for which there would always be a sufficient number of fellows on account of the meetings of the American Association. It is also a question whether it is wisest for the American Association to have for its meetings a week broken by Saturday and Sunday. The temptation for members to go to their homes on Saturday is well-nigh irresistible and comparatively few return. As a result the final sessions have few attendants and the available candidates for sectional officers who are actually present on the day of election are few. A session beginning Tuesday and closing Saturday would have many advantages.

J. F. KEMP.

COLUMBIA COLLEGE.

*THE RELATIONS OF THE INDUSTRIES TO
THE ADVANCEMENT OF CHEMICAL
SCIENCE.**

We justly congratulate ourselves that development and progress in chemistry, both

* An address before the American Association for the Advancement of Science, August 29, 1895, by the Vice-President, Section C.

in science and technology, have been more rapid in the past three decades than ever before, and that as much has been accomplished in this period as in all the years preceding since reactions have been known and applied. New elements, new compounds, new theories and new laws have followed each other in the manifold directions with such enormous rapidity that few have been able to keep informed of all, and most of us of only a few, of the discoveries and generalizations that have been made. It is for the purpose of exchanging information on these subjects that we come together at the present time, and it has been the custom of the Chairman to discuss one or another of these lines of progress, setting forth the most important of what has been developed in the more recent times. In many of the discussions and addresses on similar occasions by those more or less closely allied with or engaged in the study of so-called pure chemistry, much has been said of the practical value of the results obtained in the scientific laboratories devoted to research, and the uses they have found in daily life. No one has arisen to question the truth of what has been said, nor could it be questioned, for the men who have been working with the most unselfish devotion to the pursuit of truth for truth's sake, and with little hope of reward for the service they have rendered, have acquired and disseminated a store of knowledge which has added so largely to the capacity of all men for work that only the most grateful acknowledgments may be offered. While all this may be accepted, it is seldom that anything is heard regarding the reciprocal influence of the industries and the ordinary occupations of daily life upon the development or advancement of chemical science, and it has seemed that, in this period of relaxation, it would be well to stop and consider what are the relations of the industries to the science from the other

side of the question, and what aid has come from the former to the latter to promote its advancement, if, indeed, any distinction can be made so far as the additions to human knowledge are concerned. For science is cosmopolitan, as it were, and omnivorous, and facts from whatever source, and of whatever kind, are greedily absorbed to form a part of the grand structure of human knowledge, whether they come from efforts made at leisure and in the quiet of the study or private laboratory, or whether they are developed in the struggle for existence and the daily bread.

In its earlier development, substantially beginning with the present century, chemistry was the newest of the physical sciences. It grew up out of the empiricism of the preceding centuries and had its foundation in the facts to be found in the daily practice of those engaged in the endeavor to meet the demands of the current needs. As civilization progresses, culture extends, demands consequently grow, and it is one of the inevitable laws of sociology and political economy, as of nature, that these demands shall be met. To meet them human ingenuity must be taxed for the determination of methods and means; and whether it be to secure immediately useful results or to establish more abstract truths, intellectual endeavor is required, knowledge must be increased and science therefore advanced. Literature is filled with description of the service which the science of chemistry has rendered to the industries and the commercial world, and the development of the tar color industry is the favorite example of this so frequently cited. History, so far as it is written, for the most part deals with the subject from this standpoint. But it may properly be questioned whether the industry was wholly the outcome of scientific research or whether science received much, at least, of its inspiration, its suggestion, its original material from the industry

already developed in an intensely empirical way. It is this side of the question that will occupy us at the present time, and we shall endeavor to call attention to some of the influences which operate from one side or the other to bring about the results indicated and to the reciprocal influences which flow from the results themselves.

The true fundamental principles of the science were not developed and set forth through the classic researches and deductions of the great leaders, Dalton, Priestley, Cavendish, Black, Wenzel, Richter, Lavoisier, Gay Lussac, Avogadro, Dulong and Petit until the close of the last and the earlier years of the present century. But even before the beginning of the last century the rapid progress of civilization and culture in other lines had made demands for the products of the chemical arts, and they were met in ways that were empirical it is true, but by reactions which were as positive then as they are now, even though they were unknown, and they furnished fertile food for study and speculation on the part of the philosophers in fields quite new to them, led them out from the libraries of the monasteries to the active work of the busy world, furnished them with facts for collaboration and classification, from which they were amply able to construct the hypotheses and build up the theories which have been of so much value to the civilized world. During the entire century the industries thrived and grew, met the demands put upon them and brought about the establishment of facts that long since were recorded as new discoveries.

The acknowledged fathers of the science of chemistry, although eminent scholars and connected with the institutions of learning, were many, if not most of them, directly interested in the manufacture of chemical products, and by their general education and higher intelligence were enabled to contribute to their material advance-

ment. At the period in which these men lived and worked, these industries could with difficulty meet the demands of the advancing civilization, and that they were profitable then, even as they were later, we learn from the experience and writings of Chaptal,* who was turned from the profession of teaching to establish at Montpellier, as he tells us, large works for the manufacture of sulphuric, nitric, muriatic and oxalic acids, alum, copperas, sal ammoniac, sal saturn, white lead and the preparations of lead, mercury, etc. He declares that he had made 'mountains of alum without being able to crystalize it,' until he had, through the analysis of Roman alum, determined the presence of potash in the crystallized product. And in order that he might have proper apparatus for his works he undertook the manufacture of the porcelain and pottery he required. A little later he became interested in dyeing and calico printing in a commercial way. How profitable this manufacture was may be gathered from the fact that after the political reverses which brought about his deposition from the public life in Paris which had consumed his entire fortune, he returned to his manufacture at Montpellier and in a single year realized from it a handsome net profit of 350,000 francs. He further relates that, encouraged by his success, other chemists of France established large manufacturing works and entered into their management. He was closely associated with Lavoisier, Berthelot, Monge, Foureroy, Carny, Vandermonde, Guyton de Morveau and others in the manufacture of gunpowder near Paris, and his memoirs show that during his residence at Montpellier he was in constant correspondence with the chemists of Paris and elsewhere. Dubrunfaut† states that at the instigation of the Comptroller-General, Turgot, the Academy

of Sciences of Paris offered a prize in 1776 for the invention of a method for the production of niter and that Stahl and Lavoisier did not disdain to take an interest in the subject of the prize. It amounted to £3000 and was awarded to Thouvenel, who was required, we are told, to justify experimentally the theory of Lavoisier. At that time Lavoisier was director of the Royal Saltpeter Works. Berthollet* was interested in bleaching and dyeing, suggested the use of chlorine for the former and in 1791 published a work entitled 'Elements of the Art of Dyeing.' Guyton de Morveau † was devoted to analytical and technical chemistry, and among other things he founded saltpeter works in 1773 and soda works in 1783.

Much of the work, therefore, not only of Chaptal but of other chemists of his time, was doubtless done in response to demands made upon them by the exigencies of the manufactures, but how many of the results they communicated to the journals and learned societies flowed directly therefrom we are not told. Certainly they could not have failed to study closely the phenomena thus offered for their observation and which in many respects could not have been as efficiently exhibited in any other way.

So also, as we are told by Meyer ‡ and other historians, the earlier contributors to the new science, Boyle, Kunkel, Bergmann, Scheele, Margraff, Macquer, Duhamel and others, were largely devoted to the development of certain chemical processes in the industries. With all these men, the other great leaders of the science were closely associated; the problems constantly arising and the results obtained in their solution were doubtless subjects of frequent dis-

* Schaedler, Handwörterbuch der wissenschaftlich bedeutenden Chemiker.

† Schaedler, Handwörterbuch der wissenschaftlich bedeutenden Chemiker.

‡ Geschichte der Chemie, Zweite Auflage, 1895.

* La Vie et l'Oeuvre de Chaptal. p. 31.

† Le Sucre. II., 95, note.

ussion and led them to profitable study regarding them and the fundamental and natural laws upon which they were based. And what was true of that earlier period of the history is true to-day and to an increasing degree must find illustration in future work. The industries are still pushing forward with earnest competition to supply the demands which grow with the years, and the hard questions which come from managers and proprietors to professional men are as numerous and as difficult in their way as those which puzzled the early philosophers and stimulate an earnestness in endeavor and investigation that brings the highest and most useful results. We must admit that without these hard questions the advances in the science itself would be less rapid and the intellectual activities of investigators less alert.

Beautiful illustrations growing out of such demands are everywhere to be seen at the present day even as they were in former years, although they are not often to be found recorded in the pages of published history. Many of us will remember the incident cited by Hoffmann* in his necrological notice of Dumas describing the circumstances which led to the discovery of the absorption of chlorine by organic bodies, in which he declares that it "is not generally known that the theory of substitution owes its source to a soirée in the Tuileries." Dumas has been called upon by his father-in-law, Alexander Brogniart, who was director in the Sèvres Porcelain Works, and, as Hoffmann says, in a measure a member of the royal household, to examine into the cause of the irritating vapors from candles burned in the ball room, a demand to which Dumas readily acceded, because he had already done some work upon the examination of wax which could not be bleached and was therefore unmerchantable. He was read-

ily led to the conclusion that the candles used in the palace had been made with wax which had been bleached with chlorine and that the vapors were hydrochloric acid generated in the burning of the candles. But examination of the wax of the candles showed that the quantity of chlorine found was greater than could be accounted for by its presence as a mechanical impurity, and from it Dumas was led to experiments which showed that many organic substances when heated with chlorine have the power to fix it, and from these results he was in turn led to the further generalization concerning the law of substitution. In this connection Hoffmann says: "This information upon the origin of substitution, which the author of this sketch had from the mouth of Dumas himself, is more than an interesting incident. We frequently see that like the Luxembourg palace, the Tuileries, besides their historical legends, have likewise scientific memories. How wonderful! A ray of sunlight reflected from the window of the Luxembourg, and accidentally seen by Malus through a plate of calc spar, revealed to him the phenomenon of double refraction, adding a new province to the domain of physics; while the acid vapors from a smoking burning candle in the ball room of the Tuileries led Dumas to study the influence of chlorine upon organic bodies, and finally led him to speculation upon this action, which for many years had controlled the science and even to-day has a mighty influence upon its development."

It would be difficult to follow Dumas through the hundreds of investigations he made in all the fields of chemical activity, clearing up the the questions arising in the various occupations of daily life and in all its departments, even as it would that of other men active in progressive work. Much of the work of Dumas, as shown by Hoffmann and the published records, was devoted to the solution of such questions,

*Berichte der Deutschen Chemischen Gesellschaft. 17 R. 667.

and much of his inspiration was drawn from them. It was an incident similar to that already described that brought Dumas to the reaction whereby hydrogen sulphide may be oxidized to sulphuric acid. He found the walls of one of the bath rooms at Aix les Bains covered with crystals of calcium sulphate, which could have no other source than the vapors liberated from the hot water. No trace of sulphuric acid could be found in the atmosphere of the room. The portières of the room soon acquired an acid reaction, which proved to be due to sulphuric acid. Dumas concluded that the combination of hydrogen sulphide with oxygen had occurred upon the wall itself, the porous surface exercising an influence similar to that of platinum black upon hydrogen and oxygen. A subsequent investigation showed that when air steam and hydrogen sulphide are passed over porous substances at from 40° to 50° C., and still better at 80° to 90°, sulphuric acid is quickly formed without intermediate formation of sulphurous acid or separation of sulphur.

Similar instances are set forth by Hoffmann*—who seems to have recognized the value of the influences we here have in mind—in his necrological address upon Liebig, whose well-known devotion to the industries and their advancement is so familiar and interesting. Hoffmann says: "No branch of chemical industry has failed either directly or indirectly to receive benefit from Liebig's works." He calls attention to the study of the fat and acetic acid industries, and declares that the key to their peculiar operations is of his making, that the preparation of the prussiates and fulminates, the manufacture of the cyanides, the production of the silver mirror, were the result of Liebig's work. His interest in the problems of agriculture and of the nutrition

* Hoffmann, *Berichte der Deutschen Chemischen Gesellschaft*, VI., 647.

of plants and animals, of physiology and pathology, led him not only to the development of many new industries, but to the establishment of many of the truths of science as well. His method for the production of artificial foods and concentrated animal extracts were not the smallest of his contributions to the industry, and the possibilities of their value and wide application in turn led to further investigation. Meyer,* quoting from Hoffmann, says: "If we could hold to view all that Liebig has done for the well-being of the human race in the industries, in agriculture or in the promotion of health, one can scarcely declare that any other scholar of his time has left a richer legacy to mankind."

And what Hoffmann has said of Liebig is also applicable to himself, for in many respects he rivalled Liebig in his intelligent comprehension of commercial and industrial needs and their value in suggesting new and fruitful lines of work. No question could be proposed to him that had not for him some germs of useful thought, and it was the utilization of such possibilities as came to him in this way that made him great. His genius for this will be illustrated in connection with the incidents in the coal tar color industry which show the relation of that great branch of human endeavor to the subject in hand.

It seems to make little difference to which branch of chemical work we turn for illustrations of the ideas just presented. The enormous losses suffered by Italy and France by the diseases of the silk worm, the deterioration of the wines and the diseases of farm animals, made demands upon the genius of Pasteur, and through his brilliant work and magnificent results attention has been directed to the field of bacteriology and fermentation, and almost a new science has been built upon it. What a mass of material has through this one branch of

* *Geschichte der Chemie*, 231.

work been added to the sum of human knowledge and what an impetus has it given to the advancement of science! The industries demanded relief from their losses, but the path to that relief is strewn with facts which have been utilized for the establishment of new principles; and the new principles, extended to the other industries, have widened still further the field and led to the study of the products developed in the growth and nutrition of the lower organisms with results the spread of whose influence it would be difficult to define.

Some of us will remember that a little more than a decade ago many of the leading chemists of this country were called upon to settle a commercial dispute in Chicago, turning upon the question of an admixture of fats in the adulteration of lards and that, on account of the lack of knowledge then prevailing regarding the exact constitution and reactions of various fats, it was impossible to arrive at satisfactory conclusions with regard to the mixtures submitted. It was embarrassing for chemists to admit the weakness, but it nevertheless had useful results. Since that time the development of knowledge concerning these products has been such that it is possible readily to determine in many cases, not only the components of such admixtures, but even the quantity of each component present.

Such illustrations in increasing numbers will occur to every one who may consider the history of the science and the industries from this point of view. The coal tar color industry, which has so frequently been cited and described as the direct outcome of scientific investigation, will serve admirably to illustrate further the relations we are considering. No one of the industries has been so rapid in growth or has attracted the same degree of attention from both scientists and technologists, or has had so wide an influence upon the progress of

the other industries and scientific work. A brief review of the conditions of its development from the standpoint of this discussion will be of interest and will serve to show how much the purely scientific side of chemistry may be found to owe to the development of the technical side.

The origin of the crude product of this industry, the manufacture of gas, is comparatively modern. Though it was known in the latter part of the last century it did not find extensive application permanently until between 1830 and 1835. But from the time of its first extended application, its by-product, tar, became a troublesome nuisance and many endeavors were made on all sides to find some means for its disposition and utilization. It was consumed by burning, it was boiled down in open vessels and its residues used as preservative paint for wood and metals; its lighter and more volatile products were subsequently collected by condensation and put upon the market as a solvent for fats, waxes, rubber, etc., and this was used in the manufacture of varnishes. According to Lunge,* Accum was the first to boil tar down in close vessels and thus obtain volatile oil which could be used as a cheap substitute for turpentine. Dr. Longstaff declares that, in conjunction with Dr. Dalton, he erected the first distillery for coal tar in 1822 near Leith, and that the spirits obtained were sent to Mr. Mackintosh, while the residue was used for making lampblack. Roscoe states that the distillation was carried on near Manchester in 1834, the naphtha obtained being used for making black varnish with the pitch. So that the lighter distillates had been furnished to the markets some years before Mansfield began, in 1847, the distillation of the lighter oils to obtain products which might be used for lighting purposes. It was in the course of this work that he de-

* Lunge. Coal Tar and Ammonia. 189.

termed the composition of the lighter oils in the market and found that they contained a considerable quantity of benzenè, a fact discovered by Hoffmann two years before. Supplies for the subsequent uses in the color industry were therefore possible.

It may be observed here that the discovery of this compound by the dry distillation of coal, *de novo*, in the laboratory, would have been practically impossible* since, according to Perkin,† 100 lbs. of coal yields only 0.85 oz. of coal tar naphtha, and 0.275 oz. of benzene. The operations of the industry carried out on a large scale are necessary to this,‡ and such operations we know and shall see have furnished to those working in purely scientific lines materials for study which has given the most important results and without which many of the relations would still be unknown.

But to proceed. With the commercial production of benzene, its derivative nitrobenzene was readily obtained in large quantities. It had been made, it is true, years before by Mitscherlich in 1834, from benzene of benzoic acid, and by Laurent a little later by the action of nitric acid upon light oil of tar. Collas, a French pharmacist, made it in 1848 in a large way in Paris and later Mansfield took up its manufacture from the product of his stills, putting it on the market as artificial oil of bitter almonds, or oil of Mirbane, to be used in scenting soap.

So aniline which Unverdorben produced in 1826 by dry distillation of indigo and called *krystallin*, and Runge first separated from coal tar by treating it with hydrochloric acid in 1834 and called *blauöl*, and Fritsche produced by digestion of indigo with potash and distillation of the product in 1840 and called *anilin*, and Zinin pro-

duced in 1842 by reduction of nitrobenzene with ammonium sulphide and called *benzidam*, remained a scientific curiosity the true constitution of which was not fully determined until some years after it had been produced by Bechamp by reduction of coal tar nitrobenzene with iron and acetic acid and Perkin had utilized it in the manufacture of mauve.

And so the way for Perkin had been prepared. Both the industry and the science, so far as they had been able, had done their share: the industry, by efforts at the utilization of the products at hand and showing possible commercial profit; the science, in the struggle after new compounds. The spirit of the iatro-chemists still prevailed and substantial benefits flowed from it as of old. Perkin,* likewise in an effort to produce a compound valuable and scarce in the market and to effect the synthesis of quinine, produced aniline purple or mauve instead. Starting out, as he says, with the consideration of the empirical formula, he concluded that by the oxidation of allyl-toluidine he might attain his end. Describing his experiment, he says: "For this purpose I mixed the neutral sulphate allyl-toluidine with bichromate of potassium, but instead of quinine I obtained only a reddish brown precipitate. Nevertheless, being anxious to know more about this curious reaction, I proceeded to examine a more simple body under similar circumstances. For this purpose I treated the sulphate of aniline with bichromate of potassium. The mixture produced nothing but an unpromising black precipitate; but, on investigating this precipitate, I found it to be the substance which is now, I may say, a commercial necessity." Perkin treated the black precipitate with different solvents in the study of its properties and found it to yield to alcohol a colored solution. With more of the inventive and commercial spirit

* Compare Roscoe and Schorlemmer, *Treatise on Chemistry*, III., pt. iii., 15.

† *Jour. Soc. Arts.* 1869. 101.

‡ Compare Hoffmann. *Jour. Soc. Arts.* 1863. 647.

* *Chemical News*, 1861. 347.

than prevailed with his illustrious teacher in whose laboratory he was working, he at once began experiments to determine whether this new color, so beautiful in its hues, could be fixed upon textile fibers, and succeeded in dyeing a strand of silk with it without the aid of any mordant whatsoever. He promptly submitted his discovery to Puller, of Perth, who tried the color in a larger way, proving its commercial value. The patents were secured and Perkin at once devoted himself to the industrial production of the color and, after more or less difficulty, always incident to the manufacture of a new substance, he attained commercial success. The tar color industry was launched; it was immensely profitable; it furnished incentive to further investigation and experiment in similar lines; a new field was opened up, and what a flood of results has come from it! In them both empiricism and rationalism have been represented, and the addition to the number of new substances whose properties and constitution have been essential to the establishment of new theories and new laws has been enormous and unprecedented in all the history of chemical work. The search after the production of a commercial product, yielded accidentally as it were, and almost empirically, the seed from which this great and flourishing tree has sprung.

For it must not be forgotten that, after Perkin had obtained his oxidation product of aniline and had found that some portion of it was colored and could be applied to the dyeing of fabrics, his study of its properties ended for the time being and it was not until 1863 that he was able to take up this subject and follow it to conclusion, establishing the constitution of the new compound.

The history of the coal tar color industry is full of examples of the production of new substances and new reactions by the industry of the highest importance to the ad-

vancement of knowledge in the domain of chemistry and to the development of the great theories to which, in turn, much of progress both in science and technology has been due. In this connection one may study, with profit and interest, the very able address of H. Caro* before the Berlin Chemical Society, on the subject of the 'Development of the Coal Tar Color Industry.' While very properly giving the fullest credit for the scientific or rational work done in this connection and the applications of it in the industries, he shows many examples of the important results attained by technical or empirical methods and of the highest interest and value to the science. He calls attention to the fact that C. E. Nicholson suggested to Hoffmann that pure aniline would not yield aniline red, and that it was not the true agent for the production of this compound. A gallon of aniline with a constant boiling point of 220° C. sent to Hoffmann by Nicholson gave such a result; while a sample of the ordinary aniline of commerce, and boiling at from 182° to to 220°, yielded an abundant quantity of color. From this Hoffmann concluded that the commercial aniline contained a second base which, together with aniline and homologous with it, entered into the reaction to produce the regular result. But Hoffmann† declared that, if such an admixture of bases existed, their separation by any other than operations on a large scale would be out of the question, a condition found by other investigators. Nicholson had already suggested the presence of toluidine in the mixture. Hoffman tried making the color with pure toluidine from tolu balsam sent him by Muspratt and found that this, too, gave a negative result. But upon mixing the pure aniline from Nicholson in proper

*Berichte der Deutschen Chemischen Gesellschaft, 25, 955.

† Berichte der Deutschen Chemischen Gesellschaft, 25, 976.

proportions with the pure toluidine from Muspratt, the proportions corresponding with one molecule of benzene to two molecules of toluene, the red color was promptly produced. In this connection Hoffmann said 'the industry was ahead of the science' and Caro said: "Hence the industry was not only the generator of aniline red, but furthermore it had opened up the way to the rational utilization of benzene and its homologues for all present and future uses of color manufacture."

Artificial alizarine has much the same kind of history. It was developed by Graebe and Liebermann by most rational methods and from the constitution and reactions of the body itself. Starting with a commercial body, produced by industrial methods and in most empirical ways, they endeavored to reproduce it by rational synthesis and succeeded. Their method through dibromanthraquinone was not, however, a commercial possibility, and it remained for Perkin, with his industrial experience and capacity, and his engineering skill combined with his knowledge of chemistry, to overcome the manufacturing difficulties and to attain this end by other means and reactions than had been proposed by Graebe and Liebermann. The process proposed by the latter was precluded by the high cost of bromine and Perkin replaced it by sulphuric acid, producing the anthraquinone sulphonic acids which yielded after the melt the product desired. The industrial genius of Perkin gave artificial alizarine and with it a long series of products and problems for study and solution by chemists everywhere. It taught reactions that were fertile in stimulating new research and established facts that could not be, or at least were not, discovered in the laboratory. For instance, in the course of the manufacture, Perkin found that when, as sometimes happened, sulphonation of the anthraquinone was not thor-

oughly effected through insufficient heating or use of too little acid, a really better product was obtained than when the process had proceeded normally. He found that in the latter case the color of the resulting product was less brilliant than when these irregular conditions prevailed; that, in the latter, the resulting paste was a mixture of colors, while with the former nearly pure alizarine was the result. Investigation confirmed the outcome of the practice and showed that from the anthraquinone monosulphonic acid only pure alizarine was produced, while from the result of higher sulphonation a mixture of products was secured. Such a discovery may have been possible only in the larger way occurring in the works and might have long been overlooked in the laboratory. At any rate it was brought out in the industrial operation of the reaction, and a new fact was added to the sum of knowledge.

This discovery brought further necessity and new invention. By the ordinary method of sulphonating then employed, the monosulphonic acid could not readily be produced and it remained for Perkin to advance both science and technology still further by the determination of a new process for attaining this end. He found* that dichloranthracene which is easily made may be as easily sulphonated and that the dichloranthracene sulphonic acid is readily converted to the anthraquinone sulphonic acid by heating with sulphuric acid, the final result depending upon the degree of heat employed in the reaction in sulphonating the dichloranthracene. He had thus not only advanced the industry in this branch of manufacture, but he had added to the list of reactions and compounds in chemistry as well.

Hoffmann received from the French color works the *quesues d'aniline*, from which he was able to separate para toluidine and the

* Jour. Soc. Arts. 1879. 577.

two new bases paraniline and paramidophenol.* Other products from the same residues enabled the great investigator to arrive at a knowledge of the mode of formation and structure of rosaniline. Later another French color-maker sent Hoffmann a well crystallized by-product which he recognized as meta-toluylendiamine which he, together with Muspratt, had endeavored to make by synthesis. He found it to have been undoubtedly produced by the Bechamp method from nitrobenzene contaminated with dinitrotoluene.

In his most interesting and valuable address, from which many of these illustrations have been obtained, Caro calls attention to other instances of contributions to the advancement of science from this great industry; the use of zinc dust in strongly alkaline solution for the reduction of nitro-bodies was worked out in the factories; safranine was produced technically several years before its structure and mode of formation were made out by Nietzki. The empirical formation of nitrodraeylic acid and β naphthylamine is cited as furnishing contributions to the establishment of isomerism in the classes to which they respectively belong. Aniline blue, produced empirically by heating together fuchsin and aniline, was found later by Hoffmann to be triphenylated rasanilin† and led him to the recognition that change of color could be produced by substituting an alkyl, phenyl or benzyl radical for hydrogen; and so started the theory, now developed into a law, that color of compounds is a function of structure, and that, in those compounds, having antifermentive, therapeutic or toxic action, the influence will vary in intensity with the position of the radical in the molecule. Thus it has been found that ortho-cresol is less active as an antiferment than the meta-compound, while this

in turn is less intense in its action than para-cresol. α Naphthol is more poisonous and more actively antiseptic than β naphthol.

The field of chemical work, here so wonderfully opened up, has done much to bring into closer contact and communion the professional men and investigators on the one hand and the practical technologists on the other. Professional men find that such union furnishes valuable material for study and most useful suggestions for work. As Hoffmann says, "the technologist is not likely to leave long without utilization any fact of science which may be developed and made valuable from the technical side;" so we find that the benefits which flow from each to each are rapidly increasing from year to year and the distinction formerly made between science and technology is rapidly being broken down, and more cordial, and therefore more useful, relations established. Such union for progressive work was established with profit to both sides by Hoffmann and Nicholson, Graebe and Caro, O. Fischer and E. Heppé and others, and the example of these authorities has been followed by the great manufacturers in all countries by the foundation in the works, of well-equipped laboratories, intended not only for control of processes by analytical methods, but for the improvement and extension of processes by careful research methods and the discovery of new principles. Ostwald* has clearly set forth the manner in which technology and science may work together in electrical work, in the various directions.

How rapidly this practice has grown will be illustrated by the fact that the great works, successors to Meister, Lucius and Bruning at Höchst, made, in 1890, from 1700 to 1800 colors† and employ 3000 per-

* *Chemische Industrie*. 1895. 212. From *Zeitschrift für Electrotechnik und Electrochemie*. 1894. 81.

† *Ost. Lehrbuch der Technischen Chemie*.

* *Proc. Roy. Soc.* 1863. 312.

† *Proc. Roy. Soc.* 13. 9.

sons including 70 chemists and 12 engineers.* K. Oehler & Co., in Offenbach, have 300 workmen and 45 chemists.† Other works of large capacity like the Badische Anilin und Soda Fabrik of Ludwigshafen, Bayer & Co. at Elbersfeld, Casella & Co. in Frankfurt $\frac{a}{m}$ likewise employ large numbers of educated chemists and engineers. This practice now extends to most of the more important manufactures. Its value was early recognized in metallurgy and it has been adopted in other lines. As a consequence a demand has been made upon the educational institutions and an influence has been exerted upon the management leading to provision of better facilities for work both in investigation and instruction.

In connection with the working force of the German color factories, it is worthy of remark, that experience has led directors to employ educated engineers alongside the research chemists and so to recognize the fact that engineering capacity is necessary to the practical and industrial application of chemical reactions. These reactions effected in the laboratory cannot always be obtained in the works in a large way without the invention of special apparatus, and frequently the most brilliant discoveries in science prove to be nothing more than mere suggestions to the industries, doubtful stepping stones to new processes or new products. The discoveries of aniline and alizarine are examples of this principle. The ammonia soda reaction remained dormant nearly half a century until it was made practical through the genius of Solvay and by means which scarcely involved chemical reactions. The Leblanc soda process, with its beautiful reactions—partly, it is true, because of the political situation—remained dormant nearly a quarter of a century before the

genius of Muspratt restored it to life. The sugar industry, the conception of Margraff and Achard, required the invention and construction of much special apparatus before it could develop into the astonishing dimensions it presents to-day. The Weldon process could be established in the industry only after a most earnest struggle extending over three years, and the final result showed that the complete reaction could be obtained only when working in the largest way.

The study of the ultimate history of any or all of these industries will show that, as they grew, they made demands upon the educated men and so both directly and indirectly contributed to the sum of useful knowledge in nearly all its branches, chemistry included.

For this reason the demand is growing for a combination of chemical and engineering knowledge in the same person. The value of this has been noticed in the lives and works of many of the leaders in chemical work, and its recognition among educators is advancing. This is illustrated in the views of Victor Meyer,* expressed as follows: "I coincide completely with Dr. Lippmann in his wish not only for an extension of his technical instruction in our own university in its present scope, but also for the further development of the same, and I would add thereto the expression of my own opinion that instruction in technical drawing ought not to be omitted in the curriculum of any university in which numerous young chemists seek their education and are likely ultimately to desire occupation in factories and works." Similar expressions have come from other high authorities in the field of education, and the wisdom of the establishment of the technical schools with provision for thorough education in all the special branches that may find useful application in the

* Grandhomme. Die Fabriken der Actien-Gesellschaft Farbwerke Meister, Lucius und Bruning.

† Dir. E. Franck. Zeitschrift für Angewandte Chemie. 1895. 444.

* Chemical News, 1894, 97.

different industries is thoroughly confirmed.

Thus far no reference has been made to the influence of the industries upon the development of analytical chemistry, and perhaps for this there is no need. It is generally accepted, or is fast growing to be, that it is an integral part of all technical work involving any kind of chemical reactions. Meyer* says: "The industry practically developed volumetric analysis. It was first used by Decroizelles and Vauquelin in an empirical way in the chemical industries with which they were connected and was finally developed rationally by Gay Lussac, who brought it to a state of perfection not greatly improved upon in many respects."

The industries of the earlier chemical history were controlled by other methods of analysis also, crude, perhaps, but serving a useful purpose and forming the foundation of the beautiful systems in use to-day.

In this particular the requirements of the industries of the present day are most exacting. Technical methods as distinguished from scientific methods have passed away, for with rapidity of operation that many of the processes call for, the utmost accuracy must likewise prevail. This is particularly true of the metallurgical industries in which many of the operations must be controlled by analysis from hour to hour. So, too, the utmost accuracy is demanded in all work controlling commercial operations, and frequently the investigation required to confirm the value of these so-called commercial methods, or the data upon which they are based, brings forth results both as to quality and quantity that are most gratifying. In at least two cases that have come to my knowledge the directors of the laboratories of great educational institutions made requests to the directors of large chemical works, asking for descriptions of the analytical methods in daily use

* Geschichte der Chemie, 339.

in the works in question, and the request was of course cordially granted.

And if the analytical methods of the technical side are recognized as of value, so too are the experimental methods. In the great German chemical works, where large numbers of chemists are employed, the force is divided into 'laboratoriums Chemiker' and 'betriebs Chemiker,' each class having its appointed work;* the first class devoted to the investigation of new ideas in the smaller way in the laboratory, producing new compounds or investigating new reactions, or, still further, controlling by analysis the operations in the works; the second class experimenting in a larger way, with larger apparatus and quantities, and even with the normal factory facilities; with either new principles deduced from the results of factory work, or with processes or products worked out in the laboratory. The results of this combination are extensive and important; most of them are covered by patents, it is true, but they are nevertheless offered to the world, soon become public property and add to the store of knowledge. How much this really amounts to is illustrated by the fact that the records show that the works of Fr. Bayer & Co. patented or described in the first half of 1895 forty-five processes and products, while during the same period there were issued to the house of Meister Lucius and Brunning thirty-seven patents. The number of specifications for chemical patents† accepted in Germany from 1889 to 1893 were respectively, 4,406, 4,680, 5,900, 6,430. Of these patents Dr. Freidlander‡ says: "If one could be certain of the excellence of all these compounds, a new era in the color industry would be imminent. Manifestly, however, even the patentees themselves find it diffi-

* Caro, Berichte der Deutschen Chemischen Gesellschaft, 25, R. 967.

† Chem. Zeit. 1894, 136.

‡ Chem. Zeit. 1894, 1184.

cult to recognize instant practical value in them. The numerous naphthylamine, amido-naphthol and dioxynaphthaline sulphonic acids were patented, not indeed because a special technical interest was claimed for them, but only because they were new and it was scarcely possible at once to determine whether they would be applicable in one direction or another."

In no direction has the application of the methods in the larger way, either in the laboratory or in the works, given richer yields in new material than in the varied uses of the electric current in chemical work. It has led to the production of new compounds or has increased the means for production of old ones, and through it additions are constantly being made to the store of material of such composition and properties that they must inevitably lead to further new discoveries or the establishment of new principles or laws. It has added greatly to our knowledge of the reactions of oxidation and reduction and has made new applications of those phenomena possible. In this connection we may refer to the processes of Hoepfner and of Siemens and Halske for the extraction of copper from its solutions, whereby, as the metal is removed from the solution at the cathode, the reduced salts are oxidized at the anode, and the solutions thus brought to the higher state of oxidation are ready for use on new portions of ore.* Similar reactions occur in the new process of Löwenherz for the production of sodium persulphate, a compound new to chemistry and resulting from the application of electricity on a scale more extended than is usually employed for laboratory work. Sulphuric acid and sodium sulphate solutions, separated by a porous diaphragm are electrolyzed with the anode immersed in the sodium sulphate. The resulting compound is comparatively unstable, yielding up its oxygen with the production of acid

* Zeitschrift für Angewandte Chemie, 1893.

sodium sulphate. And since this latter may readily be neutralized by sodium carbonate, the new compound is recommended for all uses in which oxidation may be applied.*

With the production of hypochlorites and the chlorates we are already familiar. It grows rapidly with the cheapening of artificial power or the utilization of natural power, until eventually the world's demand for them must be covered by materials from this source. The reaction necessary to this is further utilized in the production of such compounds as chloral, iodized phenol and other similar substances.†

In the field of reductions reference may with interest be made to the late discoveries of Gattermann and the color works of Fr. Bayer & Co., that electrolysis is readily applied to the production of a large number of compounds not heretofore produced technically but for which technical uses constantly exist. Their earlier discovery of the application of electrolysis to the reduction of nitrobenzene to amido-phenol with intermediate production of phenyl-hydroxylamine finds wider application than they at first supposed and will doubtless constitute the starting point of a new line of synthesis of the carbon compounds.‡ This reaction is similar to that of zinc dust in alkaline solutions, preferably in alcohol containing calcium chloride whereby, as noticed by Wohl and Bamberger, phenyl-hydroxylamine is produced instead of the aniline produced by the reduction with acetic acid and iron.

The electrical smelting furnace has opened up a wide field of experiment and investigation as fascinating as it is new, and it is to be expected that many additions will be made to the list of new substances through its use. The increased production of chromium and the crystallization of carbon by

* Zeitschrift für Angewandte Chemie, 1895, 349.

† Chem. Zeit., XIX.

‡ Chem. Zeit., XIX., 1111.

Moissan,* the production of carborundum by Acheson, the production of the various carbides by Moissan, Wilson, Borchers and others are of great interest from both the technical and scientific side. Whether the calcium carbide, which has been so much discussed and seems such a valuable material for the production of acetylene, will at once take and hold the high position assigned to it by its inventors is still an open question. But whether it shall find extended application in the industries or not; whether it will prove too expensive to compete with benzene as an enricher of an illuminating gas, or as a raw material for the synthesis of alcohol or other substances in a commercial way, it will serve as a convenient and sufficiently inexpensive source of acetylene for experimental purposes, and it will therefore without doubt still become the starting point for many valuable investigations. Nikodem Caro† has already applied the method of Berthelot to the syntheses of alcohol with acetylene liberated from calcium carbide and shown that the yields are so far from the theoretical amounts that immediate application in this direction is at least doubtful. But the results illustrate the possibilities of the advancement of the science through these technical or semi-technical methods.

It would be impossible in such a discussion as this to cover more than a few of the manifold ways in which the science of chemistry has been advanced by the industries, their wants and their wastes. The former have led to the establishment of the great systems of technical schools provided with the magnificent library and laboratory equipments, the state and national experiment stations, the various official boards and commissions for the study of those questions which immediately affect the general welfare, and from each and all of these

sources come reports of advances which are most gratifying. The latter,* that is, the industrial wastes, gave us new elements and new compounds and so furnished the material for the establishment of new laws. The soap-boiler's lye gave iodine, the wastes of salt gardens gave bromine, the mother liquors from the springs gave cesium and rubidium, the acid chambers selenium and thallium, and the mines and metallurgical works gave gallium and germanium.

Whether we consider this side of the subject of the advancement of our science from one direction or another, we shall find ample encouragement for combination of forces and for closer union of professional and technical workers in our general field of activity. For the benefits from one side must bring reciprocal benefits from the other.† The principle of action and reaction is as true and as applicable here as in the great domain of physics. Necessity is the most natural stimulant to effort, and honest investigation must call to her aid all knowledge whatever its source and all methods however they may be acquired, and where this is the moving spirit progress is most active. Dr. Ostwald says most justly that "the secret of German industrial chemistry is the recognition that science is the best practice." Is it not equally true that practice which leads to the development of truth is the best science?

WILLIAM MCMURTRIE.

NEW YORK.

AMERICAN MICROSCOPICAL SOCIETY.

THE eighteenth annual meeting was held in the buildings of Cornell University, Ithaca, N. Y., August 21-23. It was characterized by a large and enthusiastic attendance and a very important program

* Roscoe and Schorlemmer, *Treatise on Chemistry* III. pt. III. 15.

† *Garol. Ber. d. d. Chem. Gesell.* 25, R. 991 Meyer, *Geschichte der Chemie*, 469-470.

* *Chemische Industrie*, 1895, 231.

† *Chem. Industrie*, 1895, 226.

both in papers and discussions. There were seven papers devoted to botanical subjects, ten to zoölogical and histological topics and fifteen to technical subjects relating to the manipulation of the microscope, its accessories and the material to be examined. Titles of some of the more important papers were the flagella of motile bacteria, by Dr. V. A. Moore, of Washington; corky outgrowths of roots, by Herman Schrenk, of St. Louis; the secondary thickenings of the rootstalks of *Spathyema*, by Mary A. Nichols, of Ithaca; the history of the sex cells from the time of segregation to sexual differentiation in *Cymatogaster*, by Professor C. H. Eigenmann, of Bloomington, Ind.; the morphology of the brain of the soft-shelled turtle and the English sparrow compared, by Susanna Phelps Gage, of Ithaca; the lateral line system of sense organs in Amphibia, by B. F. Kingsbury, Ph. D., of Defiance, Ohio; the primitive source of food-supply in the great lakes, by Professor Henry B. Ward, of Lincoln, Nebraska; formalin as a hardening agent for nerve tissue, by Dr. Wm. C. Kraus, of Buffalo, N. Y.; the use of formalin in neurology, by Dr. P. A. Fish, of Ithaca, N. Y.; and a practical method of referring units of length to the wave length of sodium light by Professor Wm. A. Rogers, of Waterville, Me.

The morning sessions (9:30 to 1) were regularly devoted to the reading and discussion of papers. Following these, on Wednesday afternoon the Society inspected the library and other university buildings and witnessed the ruling of micrometers with a Rogers dividing engine in the physical laboratory. In the evening President Gage delivered the annual address before the Society.

On Thursday afternoon the Society was treated to an excursion on Cayuga Lake by the citizens of Ithaca. The enjoyment of this excursion was greatly increased by the kindness of Professors Tarr and Williams,

who explained the geological formations met at the various points.

In the business session on Friday afternoon the project for an international bibliographical bureau of zoölogy was brought before the Society by Professor H. B. Ward, and it was unanimously decided to present the bureau with the proceedings of the Society and also to grant a subsidy of \$25 for the coming year.

For the coming year the following officers were elected: President, Dr. A. Clifford Mercer, F. R. M. S., of Syracuse, N. Y.; Vice-Presidents, Edward Pennock, of Philadelphia, and Miss V. A. Latham, M. D., of Chicago; Secretary, Dr. Wm. C. Krauss, of Buffalo, N. Y.; Executive Committee, Dr. C. H. Eigenmann, of Bloomington, Ind; Dr. Hermann Schrenk, of St. Louis, Mo., and Miss M. A. Booth, of Longmeadow, Mass.

The following is a complete list of the papers presented:

1. *Some Notes on Alleged Meteoric Dust*: MAGNUS PFLAUM.
2. *Corky Outgrowth of Roots and Their Connection With Respiration*: H. SCHRENK.
3. *A Practical Method of Referring Units of Length to the Wave Length of Sodium Light*: PROFESSOR WM. A. ROGERS.
4. *Some Peculiarities in the structure of the Mouth Parts and Ovipositor of Cicada septendecim*: PROFESSOR J. D. HYATT.
5. *The Lateral Line System of Sense Organs in Amphibia*: DR. B. F. KINGSBURY.
6. *The Chlorophyll Bodies of Chara Coronata*: PROFESSOR W. W. ROWLEE.
7. *Secondary Thickenings of the Rootstalks of Spathyema*: MARY A. NICHOLS.
8. *Comparison of the Fleischel, the Gower and the Specific Gravity Method of Determining the Percentage of Hemoglobin in Blood for Clinical Purposes*: F. C. BUSCH and A. T. KEER, JR.
9. *The History of the Sex-Cells From the Time of Segregation to Sexual Differentiation in Cymatogaster*: PROFESSOR C. H. EIGENMANN.
10. *A Fourth Study of the Blood Showing the Relation of the Colorless Corpuscle to the Strength of the Constitution*: DR. M. L. HOLBROOK.

11. *Two Cases of Intercellular Spaces in Vegetable Embryos*: K. M. WIEGAND.
12. *The Fruits of the Order Umbelliferæ*: DR. E. J. DURAND.
13. *The Action of Strong Currents of Electricity Upon Nervous Tissue*: DR. P. A. FISH.
14. *The Morphology of the Brain of the Soft-Shelled Turtle and the English Sparrow Compared*: SUSANNA P. GAGE.
15. *The Flagella of Motile Bacteria*: DR. V. A. MOORE.
16. *The Primitive Source of Food Supply in the Great Lakes*: PROFESSOR HENRY B. WARD.
17. *Some Experiments in Methods of Plankton Measurements*: PROFESSOR HENRY B. WARD.
18. *The Fruits of the Order Composite*: PROFESSOR W. W. ROWLEE and K. M. WIEGAND.
19. *The Spermatheca and Methods of Fertilization in Some American Newts and Salamanders*: DR. B. F. KINGSBURY.
20. *Cocaine in the Study of Pond-Life*: PROFESSOR H. S. CONSER.
21. *Paraffin and Colodion Embedding*: PROFESSOR H. S. CONSER.
22. *Formalin as a Hardening Agent for Nerve Tissue*: DR. WM. C. KRAUSS.
23. *The Use of Formalin in Neurology*: DR. P. A. FISH.
24. *The Lymphatics and the Lymph Circulation With Demonstrations of Specimens and Apparatus*: DR. GRANT S. HOPKINS.
25. *New Points in Photo-Micrographs and Cameras*: W. H. WALMSLEY.
26. *The Question of Correct Naming and Use of Micro-Reagents*: MISS V. A. LATHAM, M. D.
27. *A New Way of Marking Objectives*: DR. WM. C. KRAUSS.
28. *Demonstration of Histological Preparations by the Projection Microscope*: DRs. KRAUSS and MAL-LONEE.
29. *Improvements in the Colodion Method*: PROFESSOR S. H. GAGE.
30. *The Syracuse Solid Watch Glass*: DR. A. C. MERCER.
31. *A Metal Centering Block*: MAGNUS PFLAUM.
32. *A New Cell and a New Method of Mounting in Glycerin*: MAGNUS PFLAUM.

NOTES ON ENGINEERING.

THE BRITISH INSTITUTE OF MECHANICAL ENGINEERS.

THE Institute held its annual convention the first week in August at Glasgow, Professor A. B. W. Kennedy presiding. The principal papers and discussions related to

the economics of gas production and of the water supply of cities as a source of hydraulic power. The list was brief but the papers valuable and purely technical. Mr. Biggart described the application of hydraulic apparatus in the operation of charging retorts and in drawing the coke. The result was the doubling of the output with a stated force of men. Some 200 of the machines described are already in use. If applied to the whole manufacture in Great Britain, the estimated saving would be some \$2,000,000 annually on eight millions of tons of coal. Glasgow and other great cities have them in use. The manager of the Glasgow works stated that the machines used in their works on a half-million tons of coal annually are in use night and day and give no trouble whatever.

Mr. Ellington described the existing systems of hydraulic transmission of power in Glasgow and Manchester, where pressures of 1120 pounds per square inch had been adopted; the customary figure being 700 to 800. Their method of transmission was succeeding admirably in intermittent work, and especially for packing presses. This power was in use, here and there, in London for operating dynamos. The charge for water is equivalent to threepence per brake horse power per hour. In South America this method has been applied in extensive drainage.

THE CONGRESS OF SANITARY ENGINEERS AND ARCHITECTS.

REPORTS of the work of Congress held recently in Paris and attended by foreign as well as French professionals indicate that much remains still to be done to complete a modern satisfactory system. More questions were propounded than answered, by far, and many schemes proposed by members were found impracticable by those actually engaged in such work. Much was said of methods of economizing water with-

out restricting its necessary and desirable use, but no methods were found free from difficulty. The technical schools teaching sanitary plumbing were commended and their extension advised, as were the professorships of sanitation in schools of architecture. Wm. Trélat's system of heating rooms and his formulation of the theory—by no means new—that heat should be radiated into rooms from warm walls, and not introduced by heating the enclosed air, were strongly approved. One method of Mr. Trélat is that of superheating the room before it is required for use, and then, by opening doors and windows, replacing the heated by cold air, thus leaving the heating to be done by radiation from the walls, and yet giving the occupants cold air to breathe. Resolutions were passed in favor of baths in schools, of cheap working-class dwellings and other social and economic improvements. The attendance was about three hundred.

GENERAL.

THE largest steamer yet constructed for carrying freight was launched at Wallsend, G. B., recently. The 'Westneath' is 465 feet long, 56 feet beam, $34\frac{1}{2}$ feet moulded depth, and can carry 10,500 tons dead weight of cargo, or 14,500 tons by measurement. The bottom is double and constructed as a system of ballast tanks. The engines are triple expansion and work at 180 pounds pressure. The hull is by Swan & Hunter, the engines by the Wallsend Engineering Co.

ENGLISH express trains between London and Glasgow and Edinburgh have for many years had schedules calling for speeds of 50 miles an hour. This has now been bettered by the London-Aberdeen express, which is scheduled to make the 540 miles in $8\frac{1}{2}$ hours. This was accomplished by the first train a month ago, and with no apparent difficulty, making the mean speed

including stops over 63 miles an hour, and probably at times between stations on level stretches above 70 miles.

PROFESSOR SYLVANUS THOMPSON, in a letter to the *London Times*, August 1st, protests against the prejudice attributed to Lord Kelvin and others in favor of continuous currents for general use, and states that experience indicated the alternating currents to be desirable for all but electrolytic work. The obvious advantages of simplicity and relative cheapness of the latter are in no other case considered by the critic to be in any important degree compensated by continuity of current. R. H. THURSTON.

SCIENTIFIC NOTES AND NEWS.

SIR WILLIAM TURNER (*Journ. Anat. and Physiol.*, April, 1895, p. 424) after reviewing the famous examples of the so-called transitional forms between apes and man, and concluding that they are without exception human, gives a detailed account of Dubois' *Pithecanthropus erectus*. The fragments on which this 'genus' is founded are also thought to be human when the single molar tooth is eliminated. The author holds that, since the crown of this tooth is not worn, while all the sutures of the cranial vault are obliterated, the tooth is from another skeleton and in all probability that of an orang.

PROFESSOR D. D. SLADE has written an elaborate paper on *The Significance of the Jugal Arch*. (*Proc. Amer. Philosoph. Soc.* xxxiv., May 13th, 1895, pp. 17.) A systematic review of the elements entering into the composition of the jugal arch in the mammalia is essayed. The author invites attention to the taxonomic value of the arch in genera and families, while acknowledging that the underlying forces which it is assumed have produced the various forms yet await elucidation.

At the approaching meeting of the British Association for the Advancement of

Science, which convenes on the evening of September 4th, there will be in addition to the address of the president, Sir Douglass Galton, three public lectures, one by Professor Sylvanus P. Thompson on *Magnetism in Rotation*, one on *The Work of Pasteur and its Various Developments* by Professor Percy F. Franklin and a lecture to workmen by Dr. Alfred H. Fison on *Color*.

THE eleventh International Congress of Americanists will meet at the city of Mexico from the 15th to the 20th of October. The meeting will be under the patronage of the President of Mexico and the most distinguished scholars and statesmen of the country. The Congress has for its object the study of the ethnography, languages and history of North and South America, with special reference to the period preceding the advent of Columbus.

THE Berlin Academy of Sciences announces that the Steiner prize (4,000 M. and an additional prize of 2,000 M.) will be awarded for a paper in continuation of J. Steiner's work on curved surfaces, which must be submitted before the close of the year 1899.

THE *Naturwissenschaftliche Rundschau* states that the 'Academia dei Lincei' at Rome has elected as correspondents, Professor Luciani, of Rome; Dr. Stefani, of Florence; Professor v. Kölliker, of Würzburg; Dr. Jordan, of Paris; Dr. Salmon, of London; Professor Ivanovitch, of St. Petersburg, and Professor Newcomb, of Washington.

PROFESSOR BERGH has been elected correspondent of the Paris Academy in the place of Huxley.

THE Intercolonial Medical Congress of Australasia announces its first meeting for February 3, 1896.

WITH the September number, the *American Journal of Psychology* enters upon its seventh volume. The preceding volumes (1887-1895) have been edited by President

G. Stanley Hall (Clark University). For the future, the editorial responsibility of the *Journal* will be shared by President Hall, Professor E. C. Sanford (Clark University) and Professor E. B. Titchener (Cornell University). A coöperative board has been formed, which includes the names of Professor F. Angell, Professor H. Beaunis, Professor J. Delboeuf, Dr. A. Kirschmann, Professor O. Kuelpe, Dr. A. Waller, F. R. S., and Professor H. K. Wolfe. The *Journal* will be devoted exclusively to the interests of experimental psychology (psychophysiology, psychophysics, physiological psychology, etc.). Each number will contain, as heretofore, original articles, reviews and abstracts of current psychological books and monographs, and notes upon topics of immediate psychological importance. Contributions may be addressed to any one of the three editors.

DR. THOMAS HENDERSON CHANDLER, dean of the Harvard Dental School, died on August 27th, at the age of 71 years.

A SPANISH translation of *Maize: A Botanical and Economic Study*, by J. W. Harshberger (No. II. of the monograph series issued by the botanical department of the University of Pennsylvania) has been made by Dr. Nicolas Leon, of Guadalupe, Hidalgo, Mexico.

D. APPLETON & Co's preliminary announcements for the autumn include the following publications: A new edition of the *Natural History of Selbourne*, by Gilbert White, in two volumes with an introduction by John Burroughs and illustrations by Clifton Johnson with the text and new letters of the Buckland edition, a translation of Dr. William Hirsch's *Genie und Entartung*, *Psychology of Number* by Dr. J. A. McClellan and Professor John Dewey, *The Story of The Earth* by H. G. Seeley, and a new and revised edition of *The Sun* by Professor C. A. Young.

EIGHTY-TWO physicians from the United States and Canada were present at the British Medical Association. The Association will probably meet in Eastbourne, England, next year.

STATISTICS have been collected by order of the German government to study the effects of the serum treatment of diphtheria. These statistics cover the first three months of 1895, and they are supplied by 232 physicians practicing in 191 hospitals. The percentage of deaths in 2,228 cases was found to be only 17.3.

THE general meeting of the *Social Science Association* is being held at Saratoga during the present week. The opening address by Dr. F. J. Kingsbury is on 'The Tendency of Men to Live in Cities.' The Association meets in the departments of Education, Health, Jurisprudence and Finance, each department having a different day set aside for the presentation of papers.

The Critic mentions a report that a posthumous volume of Huxley's essays will be brought out soon. It will contain most of his later writings, including a notable article finished just before his death. *The Life and Letters of Thomas H. Huxley*, edited by his son, is announced.

HENRY HOLT & Co. announce for publication in the autumn an introduction to the geological history of organisms entitled *Geological Biology* by Prof. Henry S. Williams; a laboratory companion to Remsen's 'Introduction to the Study of Chemistry,' entitled *Remsen and Randall's Chemical Experiments*, by Prof. Ira Remsen and Dr. Wyatt W. Randall; *Grasses of North America*, by Prof. W. J. Beal; a new and much enlarged edition of Prof. W. T. Sedgwick and Prof. E. B. Wilson's *General Biology*, and translations of Kerner and Oliver's *Natural History of Plants* (2d Vol.), and of Hertwig's *General Principles of Zoölogy*.

UNIVERSITY AND EDUCATIONAL NEWS.

PROFESSOR MARK W. HARRINGTON has accepted the presidency of the University of Washington.

GEN. J. WATTS DE PEYSTER has provided for the erection of a college of languages for the American University of Washington. The building will bear his name and a bronze statue of the donor will be erected in front of the college.

WE have received the new prospectus of elective studies of Michigan Mining School. It states that the Board of Control and Faculty of the School have unanimously decided to adopt an elective system in the institution for the future, and the prospectus is issued to explain such variations in the course of instruction as will be introduced by this change. The elective system will go into full effect on September 16, 1895.

As stated in our issue of August 9th means of attracting foreign students to the University at Paris are being considered by a Committee specially appointed for the purpose. With this object in view, according to *The Nation* the University confers this year 'diplomas d'études Supérieures d'histoire et de géographie,' which may be obtained by all students including those who have not yet taken the B. A. degree. Students at the University can thus obtain official recognition of their work after having resided at the University for a comparatively short time.

THE announcement of the department of geology and paleontology of Union University for the ensuing year is received. In the advanced work particular attention is given to the paleontology and field geology of New York. During the spring term the last two days of each week were spent in field work, and typical exposures of all the formations ranging from the Potsdam in the Cambrian up to the Catskill of the Devonian were studied. This summer Prof. Prosser is studying the distribution and classifica-

tion of the Upper Devonian in central and eastern New York for the State Survey.

FIVE graduates of Michigan State Agricultural College, who were assistants or instructors, have recently been elected to other positions, as follows: F. B. Mumford, professor of agriculture, State University, Columbia, Mo.; A. T. Stevens, professor of agriculture at Green borough, N. C.; W. L. Rossman, chemist to State Pure-food Commission, Lansing, Mich.; U. P. Hedrick, professor of botany and horticulture, Corvallis, Oregon; A. B. Cordly, professor of entomology, Corvallis, Oregon.

It is stated that Dr. Wilhelm Roux, of Innsbruck, has been called to the chair of anatomy in the University of Halle; Dr. K. Seubert, of Tübingen, to the chair of chemistry in the Technical High School, at Hannover, and Dr. Kallius, of Göttingen, to the chair of anatomy at Tübingen.

D. C. HEATH & Co. have in preparation 'The Connection of Thought and Memory: a Contribution to Pedagogical Psychology,' by H. P. Lukens, Ph. D., with an introduction by Dr. G. Stanley Hall. The work is based on F. W. Dorpfeld's 'Denken und Gedächtniss.'

ACCORDING to the London *Times* the French have unearthed at Delphi the building that Pausanias describes as the 'Treasury of the Athenians;' and here they have discovered the remains of two large slabs of stone inscribed with words and music. In their first season's work they found 14 fragments of various sizes, of which they published an account last year. Four of these fragments were distinguished from the other ten by a difference in the notation of the music; and these four made up the piece that was introduced to the public as 'The Hymn to Apollo.' Fortunately, in their second season's work, the French have found another large fragment, to which the remaining ten can be

adjusted with tolerable certainty; and now we have a second hymn. The decipherment has been intrusted, as before, to MM. Henri Weil and Théodore Reinach, and their version is about to be published in the *Bulletin de Correspondance Hellénique*. The duration of the musical notes is indicated by the syllables that were sung with them. Thus, for example, where three notes are attached to a word of one long syllable followed by two short syllables they must answer roughly to a crotchet followed by two quavers. The pitch of the notes is indicated by various letters of the alphabet. In the first hymn the letters were those that the Greeks prescribed for use with voices; but in this second hymn they are those that were prescribed for use with instruments. As the Delphians would hardly have written down the accompaniment and omitted the song itself, we must suppose that the instruments and voices were here in unison.

ROBERTS BROTHERS will publish in the autumn a work on the history and topography of Constantinople by Professor E. A. Grosvenor, of Amherst College.

THE *Tribune* states that *The American Museum of Natural History* has received twenty skeletons exhumed by Mr. H. I. Smith in Mason County, Ky. The skeletons are in bad condition, but the ornaments and implements, including bone fish-hooks, are said to be of special interest.

A HURRICANE station has been recently established in Yucatan, and observations will be cabled from Mérida to New Orleans. It is hoped that the coöperation of the Mexican Meteorological Bureau will be secured with a view to establishing stations at intervals along the borders of the Gulf.

THE *Scientific American* states that Dr. Cornelius Herz has invented an improvement in telegraphy, by which more than 1,000 words can be transmitted by long

submarine cables in the same time that 20 words can be sent now. Dr. Herz's invention would allow of cabling 50 words at a cost of five cents, and would render submarine telephony and multiplex telephony feasible.

CORRESPONDENCE.

THE NATURE OF VOWELS.

THERE is one statement in Professor Le Conte's letter in SCIENCE (Aug. 16th) which seems to me worth further examination. He writes, "Now it is true that the vowels are true musical tones, but it is not true that each has its own pitch."

In a paper on the voice published in the *Journal of Physiology*, Vol. IV., 1883, I took ground on this subject at variance with the view set forth by Professor Le Conte at least in its most rigid form. I consider his statement a partial truth only.

My paper is not at hand, so I cannot quote from it, but the matter was put somewhat thus: There is but one position of the vocal apparatus—vocal bands and supraglottic parts—no structural and functional combination so far as the human vocal mechanism is concerned for the perfect production of each vowel, and the further this is departed from the greater the deviation from this true and perfect result. It will be noticed that the entire range in pitch in ordinary conversation is very limited, and even in the most exciting dramatic passages the range covers but a few notes. Moreover, the best classic music and the popular songs that are most lasting and effective have a limited range, all of which is a matter of considerable significance, but part of that significance is owing to the fact that the proper production of the vowels in their purity is determined as I have indicated; and the poet, orator, actor, singer or composer who recognizes this principle will prove so far as this can go most successful. Compare such words as 'roar' and 'scream.' What effect would 'roar' produce if spoken or sung at a very high pitch or 'scream' at a very low pitch?

Now, if any one doubts as to this let him make the simple test of singing the vowels o,

u, a, at his highest pitch, and at the same time require some listener to name the vowel he is attempting to produce. I venture to say that there will be some very ludicrous answers, and I think the majority of persons will be convinced then that pitch does go a long way in the *proper* production of vowels. That something more or less like them may be produced at different points in the scale I do not question and, of course, we accept in practice these departures from the proper vocal effect or best result if not too great. WESLEY MILLS.

PHYSIOLOGICAL LABORATORY,
MCGILL UNIVERSITY, MONTREAL.

THE 'DATE OF PUBLICATION' IN THE LIGHT OF THE LAW OF PRIORITY.

THE American Association for the Advancement of Science, in common with its sister organizations in Europe and in Australasia, has repeatedly had occasion to consider the question of scientific nomenclature; and as a result of many deliberations, zoölogists have practically agreed upon a code of rules, which have now been adopted by the International Congress and should be followed by every worker. These rules, as well as their predecessors, contain the so-called law of priority; and in consequence, the entire structure is made to depend on last analysis upon the 'Date of Publication.' How important it is then to define exactly what is meant by this term!

The present rules, adopted by the International Congress through the initiative of Dr. Raph. Blanchard, show a distinct advance in that they declare that the date at which a paper is read before a learned society does not constitute publication in the sense of this law. A thing to be published must be printed. Some still maintain that a memoir is published as soon as it leaves the hands of the author after the last corrections have been made upon it. I am even told that this is the ruling in certain legal cases—patents and the like. It is, however, a date which is in practice impossible to establish, and is consequently wholly unfitted for such a code of rules. These rules are confessedly arbitrary to a certain extent, and it is by no means necessary that we should avoid setting up a somewhat artificial rule in this case as well.

Such a step was taken by Dr. Blanchard in his first report, when he declared that publication in a daily newspaper could not be regarded as publication in this special sense, *e. g.*, the *Rostocker Zeitung*, though official organ of the *Rostocker Verein*.

Similarly it has been proposed that the date of publication should mean the date at which the printed work issues from press. This is an arbitrary ruling, and yet I fear it is not one which meets the needs of zoologists. Let us suppose the case that a printed memoir lies for months in the desk of the author, unknown to any of his colleagues. Is it wise for us to accept a rule which shall give this withheld memoir priority over one which, though it was printed later, had already been long known to specialists? Such a course would result in a needless revision of established names and could surely raise no claim to being convenient.

But the third possibility is the one which has already won the support of the majority of zoologists, and should, in my opinion, be incorporated into our rules. The difficulty, however, would be only half solved; we should know what the criteria are, but we should be at a loss to apply them, for the *date of distribution* can almost never be accurately determined. The date which the publisher uses is, as everyone knows, utterly untrustworthy. One does not need to have been specially occupied with bibliographical matters to know that the dates on the title pages of our scientific monthlies do not correspond with the time of issue; but that the 'June' number appears in May, etc. I have collected a large number of instances among journals upon whose dates we are more accustomed to rely, in which it was shown by internal evidence that the preface was written after the 'date of issue,' etc. I shall not publish this list, for it is something which everyone must have met in his own experience, and I do not wish to single out certain journals for criticism.

There seem to be but two ways to remedy this evil: either a reform must be worked in our methods of publication, or a date must be affixed by some competent agency. The former course is not likely to find favor, I fancy, with persons who have had experience in such matters. The second means seems to involve

undue complication. Surely it is not necessary to maintain a recording agency for the single purpose of settling trifling disputes of priority. The case becomes, however, singularly simplified when we consider that the new bibliographical Bureau for Zoology* can readily undertake this task without materially increasing its labor. Indeed, it could do this simply in consideration of the greater promptness with which it would receive the publications for its index. In view of this circumstance, it seems desirable to make the following suggestion in regard to the date of publication:

The Bibliographical Bureau should record with each paper a date of approximate distribution, to be determined by the date at which the paper was sent to the Bureau. For this determination, the Bureau might (1) use the postmark; (2) deduct from the date of receipt the number of days ordinarily required for the transmission by post from the place of publication to the Bureau (this in case the postmark should prove illegible), or (3) record the date at which the paper might have been mailed as a registered package. The ideal solution of the question would seem to be, since we have already the precedent of arbitrary rules adopted for convenience, to declare that not merely must a description be printed, it must also be placed on record. I would not be understood as advocating the incorporation of such a modification into our law priority. The practice would have to become quite general for such a step to be possible. I am, however, of opinion that it would be very desirable for the A. A. A. S. to take the necessary steps towards introducing this custom. HERBERT HAVILAND FIELD.

ELECTRIC STORM ON MOUNT ELBERT,
COLORADO.†

THE daily course of the weather was very peculiar and singularly uniform: The mornings

*The new bibliographical bureau is described in SCIENCE, N. S., II. p. 234.

†A storm experienced by Mr. Welker while occupying a triangulation station of the Coast and Geodetic Survey on Mt. Elbert, Colorado, in July, 1894. Mt. Elbert is about 14,440 ft. elevation. The camp was only one hundred yards from the summit.

invariably dawned clear and beautiful. Details in distant valleys and on the horizon a hundred miles away were clearly discernible. Not a cloud could be seen above or below. About eight o'clock in the morning a faint mist would begin to make its appearance at numerous places far below the station. This would slowly ascend until at last every object below was completely lost to view. By noon the mist, now become a dense cloud, would reach the camp. It would then be difficult to distinguish objects only a few yards distant. Then the electric performance began. A loud buzzing sound pervaded the atmosphere. Everything was heavily charged with electricity. From every projecting point, from the tops of tent poles, from sharp pointed rocks, balls of electric fire shed an uncanny light. These lights varied in size from that of a small incandescent lamp to globes four inches in diameter. We could draw electric sparks from pieces of metal; from the walls of the tents and from each other's bodies. Our hair would stand on end and men's whiskers would frequently be aglow. At one time a ring of electric light encircled the rim of my hat like the pictured halos of the old masters. Every one on the summit would experience a tingling, pricking sensation and occasionally quite a violent shock. These feelings were very often decidedly uncomfortable, but they could be prevented by lying flat upon the ground. Animals upon the summit frequently became so restless from their electrified condition that it was necessary to let them go down the mountain.

These phenomena would continue for about one hour. The nature of the manifestations would then suddenly change and frequent discharges would occur. At once it would seem that the concentrated fire of all the artillery of heaven was poured upon Mt. Elbert. Lightning, thunder, hail and snow followed with such fury that it often seemed that the station must be abandoned to save the lives of the party. The flashes of lightning were almost continuous and peal after peal of thunder crashed around us like the roar of a ceaseless bombardment of which we were the unwilling targets. These fearful storms would invariably continue until nine o'clock at night. The phenomena of balls of light, hair standing on end, etc., etc.,

ceased at once when lightning and thunder began. Such phenomena were to be seen only when a cloud passed over the mountain's peak without producing lightning.

Although the party escaped surprisingly well, considering the violence of the assaults, considerable damage was done by the lightning. The observatory and theodolite were struck twice, the vertice circle twice, the azimuth mark once, and a rock cairn near the summit once.

The first damage done was on July 12th, at eight o'clock in the evening, during a furious hail storm. Simultaneous with a vivid and dazzling flash of lightning there came a crash of thunder that shook the mountain top itself and drove terror to every heart.

For a short time after this tremendous discharge not a sound was heard from any one. All were certain that lightning had struck the camp, but where was the damage done? The storm was still raging furiously and an examination was impossible at the time. Word passed from tent to tent assured us that all members of the party had escaped.

As usual, the following morning was clear and bright, and our steps were at once turned to the observatory and the damage done by the lightning the night before quickly ascertained. A small round hole about the size of a pea was burned through the canvas roof of the observatory. The lightning had struck the theodolite on the end of the sunshade or dew-cap and had melted a semicircular notch in its edge. Drops of molten metal had splattered over the objective and small bullet-shaped fragments of aluminum were scattered around. The anterior lens of the objective was badly cracked, probably from the heat of the molten metal, as the remainder of the objective was uninjured. The brick pier which supported the iron stand of the instrument had been partially torn to pieces and a good sized hole had been burnt in the floor. An examination of the theodolite showed that the pivots, the wyes and the foot screws were all badly burnt. The damage was repaired as well as the means at hand would permit, the rough places on the bearing surfaces being smoothed with an oil stone.

Having thus put the instrument into fair working order, observations were resumed.

We had some little faith in the truth of the old saying that lightning never strikes twice in the same place, and as all signs of the storm had disappeared we now felt reasonably secure.

By noon, however, the weather again changed and we experienced almost an exact reproduction of the events of the day before.

This time the bolt of lightning struck earlier in the evening and caused somewhat greater damage. A small round hole was pierced through one of the two-inch rafters of the observatory roof. The theodolite was again struck, a second notch being melted in the rim of the sunshade. The molten metal was again splattered over the objective, and the pivots, the wyes and all bearing surfaces where two different pieces of metal came in contact were burned as before. This time the brick pier was completely shattered and an eight-inch furrow was ploughed through the rocky surface of the summit for about fifteen yards, when it disappeared beneath a snow bank. A little later upon the same evening a bolt struck the verticle circle, but did comparatively little damage to that instrument. A hole was burnt in the tent, the ridge pole was somewhat splintered, the wooden stand which supported the instrument was badly shattered, and a small furrow was ploughed through the ground. A small blister upon the circle showed the effect of the passage of the electric.

In my former experience I have found that all electric phenomena were more marked and the shocks more violent on sharp, isolated peaks. For some reason, Mount Elbert seems to be an exception, and I have come to the conclusion that there must have been something powerfully attractive in the rock composing the peak, perhaps a bed of magnetic ore.

P. A. WELKER.

SCIENTIFIC LITERATURE.

The Principles of Physics. By ALFRED P. GAGE, Ph. D. Boston, Ginn & Co. 1895. Pp. 634, with 493 illustrations.

Thirteen years ago the author of this textbook, after many previous years of practical experience as a teacher in high school work, put forth a manual for high schools, the guiding principle of which was expressed in the words,

'Read Nature in the Language of Experiment.' He advocated the plan of putting the pupil from the outset in the position of an inductive inquirer, of placing in his hands the simplest apparatus that could be made available, and of causing the experiment, whenever possible, to precede the formulation of the truth to be apprehended.

There were already many others who believed in the extension of the objective method of instruction to all subjects in which it could be made applicable, but Dr. Gage's position was so radical as naturally to cause much healthy discussion in relation to the practical limits of the inductive method in schools. The opinion is now very generally held that, in the teaching of physics, laboratory practice should either accompany or closely follow the study of principles; but it can scarcely be said that there are very many successful teachers who now advocate the plan of trying to make original discoverers of all the students who are required to become acquainted with the elements of physics within the limited time usually allotted in a high school or college programme. The brighter pupils may indeed be so directed as to be led to the rediscovery of some long-known truths; but these are also the ones whose eagerness causes them to devour with avidity all the information they can glean from books. The prescribed experiment is performed and the corresponding deduction is correctly expressed; but the knowledge had been acquired beforehand, so that the experiment merely confirms what had already been apprehended, instead of opening out a new avenue to knowledge. Pupils whose ability is only medium, or less than average, may follow the instructions given, but are seldom able to formulate the corresponding law except under guidance. Original discovery is for them out of the question. No law of nature has ever been discovered, even by a mature investigator, as the outcome of a single experiment; and the most successful investigators are keenly alive to the difficulty of so isolating the conditions of experiment as to exclude what is confusing or misleading. No one is ready to make a discovery in physics without considerable preliminary knowledge of principles.

In the present volume Dr. Gage avoids insist-

ence upon the doctrine to which he gave such emphatic expression in its predecessor. He states that it is simply a text-book, not a laboratory manual, but that its teachings should be supplemented by laboratory work and that "experiments are introduced chiefly for the purpose of illustrating principles and laws." With this clear statement of the object in view, he writes, not a revision of the older volume, but an independent expression of his riper experience in adapting the expression of truth to the capacity of those for whom the book is intended. These are in the main high school pupils, but a considerable amount of interesting material is introduced that is confessedly beyond the range of most of these pupils. The book is intended to include two courses, one for the high school and the other an advanced course suited for 'the requirements of the so-called classical courses in many colleges.' In such courses it is customary to avoid mathematical difficulties as far as possible; but it is safe to say that in many of them, certainly in our leading colleges, the course in general physics is so given as to include many applications of not only algebra and geometry, but also plane trigonometry and elementary analytical geometry. Indeed, the careful avoidance of equations, and the almost entire exclusion of trigonometry from the present volume, necessitates such fullness of verbal explanation as to amount to redundancy in some parts.

But, despite the objection just expressed, the explanations contained in this text-book are always clear, and the work has been admirably done. On every page are the marks of the skillful teacher, methodical, careful and accurate. To say that there are no mistakes would be, of course, inadmissible, but they are unusually few. The author has been alert in keeping up with the results of recent physical investigation, and many old definitions and technical terms have been so modified as to adapt them to modern demands. The book will undoubtedly be very useful, not only in the high school, but as a book for parallel reading by the college student, whose course in the class room is more mathematical, but who wants the 'plain English of it' where difficulties are encountered. To such it can be heartily commended, although

he will perhaps find less than he wants on some special topics, such as elasticity, moment of inertia, and the physical pendulum. The presentation of the elementary principles underlying the dynamo, the motor, the transformer, and other familiar applications of electricity will be found particularly good.

A few words of adverse criticism may perhaps be applied to some points that are capable of easy modification and relatively of inferior importance.

The term 'centroid' is employed in many places where 'center of mass' is implied. The latter is explicit; the former is unnecessary. The two expressions are used about equally frequently. Centroid has not come into general use, whatever may be the objection to such generally used expressions as 'center of mass,' 'center of inertia,' or 'center of gravity.'

In saying (p. 223) that 'if two tones form a narrower interval than a minor third, the combined sound is harsh and grating on the ear,' the author forgets that this is not true for the higher parts of the musical scale. These facts were fully investigated by Mayer about twenty years ago.

The specific heat of water (p. 263) is represented to increase continually from 0° to 80° C. The figures given are those of Regnault (1850). More recent careful investigation by Rowland and others has shown that the specific heat of water decreases slightly from 0° to about 30° and then increases gradually to 100° C.

Absolute zero (p. 273) is said to be 'a point of absolute cold or absence of heat, beyond which no cooling is conceivable.' This statement is admissible only on the assumption that the laws of Boyle and Gay Lussac are applicable rigidly at even the lowest temperatures, an assumption which is now known to be not admissible.

It is stated (p. 417) that 'carbon bisulphide is exceptionally transparent to all forms of radiation.' This may be qualified by adding 'except the violet and ultra-violet.'

There are a few other points, the noting of which would unduly extend this criticism. There are few text-books in which the first edition is so free from serious errors.

W. LE CONTE STEVENS.

Die Theorie der Parallellinien von Euklid bis auf Gauss, eine Urkundensammlung zur Vorgeschichte der nichteuklidischen Geometrie, in Gemeinschaft mit Friedrich Engel, herausgegeben von Paul Stäckel. Leipzig, Teubner. 1895. [July].

This book is a striking example of one of the many beneficent characteristics of our present civilization. Here all the works which show the gradual but sure development of the human mind toward an achievement of modern thought unsurpassed for interest and importance, books so rare that, so far as I know, not one is contained in any public library on the western continent, are put within the reach of the poorest student. Here we have, edited with the most painstaking accuracy, Wallis, Saccheri, Lambert, Schweikart, Taurinus, the forerunners of the non-Euclidean geometry.

The jump made by Bolyai and Lobachevski, the Magyar and the Russian, will no longer seem so bewilderingly long and unanticipated. How they, about the same time, 1829, came to publish each a complete, a full-fledged non-Euclidean geometry was a problem which provoked an unfortunate pseudo-solution, a hypothetical construction, which is still repeated, and even to be found in the pages of SCIENCE. [March 29, 1895, pp. 357-8.]

After a lecture on Saccheri at the World's Fair Science Congress, since published under the title 'The non-Euclidean Geometry Inevitable,' in the *Monist*, July, 1894, pp. 483-493, Professor Felix Klein, of Goettingen, who was present and said that never before had he so much as heard even the name of Saccheri, was asked why in his *Nicht-Euklidische Geometrie*, 1889-90, he says: "Kein Zweifel bestehen kann, dass Lobatschewsky sowohl wie Bolyai die Fragestellung ihrer Untersuchungen der Gaussischen Anregung verdanken" [p. 175, Zweiter Abdruck, 1893]. He answered, that he believed he would be justified when Schering published the 'Nachlass von Gauss.' Such special personal information from Schering perhaps is referred to on the preceding page, 174, in the sentence: "Dies sind die saemmtlichen Notizen, die man in *allgemeinen Kreisen* ueber die Gaussischen Untersuchungen, betreffend die nichteuklidische Geometrie besitzt."

This very question to Professor Klein, as to how he could justify his ungenerous statement, must have been again put to him by Engel and Stäckel, and he must have given essentially the same answer; for, after stating his opinion, they say of it, p. 243: "Eine Entscheidung ueber die Richtigkeit dieser Vermutungen wird kaum moeglich sein, solange der Nachlass von Gauss der Forschung unzuganglich ist."

But how little we can trust the unchecked judgment of Klein in this matter is strikingly shown by what he says of Gauss's letter to Bolyai of 1799, on this very page 174: "Dies ist das interessanteste hierher gehoerige Dokument, da es noch ganz aus Gauss' Jugendzeit stammt. In diesem letzteren Brief ist besonders gesagt, dass es in der hyperbolischen Geometrie ein Maximum des Dreieckinhaltes gebe."

This letter is given in full in the English translation of the *Science Absolute of Space* by Bolyai János, and again in the *Monist*, (p. 486), and is reproduced by Staeckel (p. 219). What it really says is about as far as could be well imagined from the statement of Professor Klein. If Schering can do no better than that, we need not wait to declare that there is not the slightest particle of evidence that either Bolyai or Lobachevski were even in the remotest degree influenced by Gauss.

A certain 'Gymnasiallehrer,' Richard Beez, mentioned slightly by Professor Klein on p. 277 of Part I. of his *Nicht-Euklidische Geometrie*, as incapable of grasping the subject, yet presumed on p. 15 of a pamphlet published at Plauen to use the expression, 'Gauss, der Lehrer von Bolyai und Lobatschewsky.' This irritating misstatement was reproduced by Dr. Emory McClintock in the *Bulletin of the New York Mathematical Society*, and when written to about it he asked Beez his grounds, and of course found there were none. In his retraction, *Bulletin*, March, 1893, p. 146, he cites, as some justification, the paragraph from Professor Klein already discussed, and says: "In the paper already cited I followed Beez in stating too strongly the probable connection between Gauss and Lobatschewsky. I am indebted for my first knowledge of Beltrami's account of Saccheri to a letter from Professor Beez, in which he admits his mention of Gauss as the

teacher of Lobachewsky to be partly inferential, and not to be taken literally." It is to be taken, we suppose, in some 'Pickwickian' sense.

This letter of Beez incited Dr. McClintock to an examination of Beltrami's article and a paper on it under the title 'On the early history of the non-Euclidean geometry,' where among other mistakes he makes one peculiarly entertaining. He says, p. 145, Bulletin, Vol. II., of Saccheri: "He confessed to a distracting heretical tendency on his part in favor of the 'hypothesis anguli acuti,' a tendency against which, however, he kept up a perpetual struggle (*diurnum proelium*). After yielding so far as to work out an accurate theory anticipating Lobatschewsky's doctrine of the parallel-angle, he appears to have conquered the internal enemy abruptly, since, to the surprise of his commentator, Beltrami, he proceeded to announce dogmatically that the specious 'hypothesis anguli acuti' is positively false." Who would suspect that all that is a pure fairy tale evolved by Dr. McClintock from his mistranslation of a passage immediately announced by the two Latin words he fortunately retained in parenthesis!

As some slight acknowledgment of the fine spirit in which the previous criticisms had been received, a transcript was made of a considerable portion of a copy of Saccheri then being translated into English, the only copy then on this continent, and sent to Dr. McClintock. After another examination and comparison of the article by Beltrami, Dr. McClintock wrote a frank acknowledgement of his mistake, but this time published no correction.

Mr. A. Ziwet, noticeable as a converted anti-non-Euclidean, repeats the older error in a review of the translation of Vasiliev's Address on Lobachevski:—"confirms the supposition that the first impulse to these studies came to him, at least indirectly, from Gauss. To the same source of inspiration must be traced the almost simultaneous, but independent, researches of the Hungarian Wolfgang Bolyai and his son Johann." [SCIENCE, March 29, 1895, p. 358.] It is rather a pity if it 'must,' since it never can be. A life of Bolyai from original Magyar sources, which is now in press, puts a totally new aspect upon the whole matter, which need not here be anticipated. These Magyar docu-

ments make it possible to offer to Professor Staeckel a slight correction, which is given as homage to the extraordinary accuracy of his book. On p. 241 the title of the *Tentamen* includes the words 'Cum appendice triplici.' Then follows the statement, "In dem dritten Anhang, der nur 28 seiten umfasst, hat Johann Bolyai seine neue Geometrie entwickelt."

It was not a third appendix, nor is it referred to at all in the words 'cum appendice triplici.' These words, as explained in a prospectus issued by Bolyai Farkas asking for subscribers, referred to a real triple appendix, which appears, as it should, at the end of the book, *Tomus Secundus*, pp. 265-322.

The now world renowned Appendix by Bolyai János was an afterthought of the father, who prompted the son not 'to occupy himself with the theory of parallels,' as Staeckel says, but to translate from the Magyar into Latin his treatise discovered in 1823, given in writing to J. W. von Eckwehr in 1825. The father, without waiting for Vol. II., inserted this Latin translation, with separate paging, as an appendix to his Vol. I., where, counting a page for the title and a page 'Explicatio Signorum,' it has 26 numbered pages, followed by two unnumbered pages of Errata. The treatise itself, therefore, contains only 24 pages—the most extraordinary two dozen pages in the whole history of thought!

GEORGE BRUCE HALSTED.

AUSTIN, TEXAS.

Chinook Texts. FRANZ BOAS. Washington, 1894. Pp. 278.

The linguist who in publishing elementary treatises on the languages of primitive peoples was the first to subjoin national texts and to comment on these texts philologically, certainly found the correct method. But it is a pity that so few of his colleagues and co-workers have followed his example, for ten pages of well-edited texts of aboriginal, oral literature accomplish more for the deeper study of these forms of human speech than one hundred pages of vocabulary or of crude, undigested grammatical information. But recently the publishing of such texts has become quite the fashion. The late James O. Dorsey intended to publish a series of works on the Omaha and Ponka language, and

the first installment of this series being a ponderous quarto volume of Indian *texts* (myths, animal stories, legends and correspondence) with notes and translation, proves that Dorsey was inspired by the same thoughts.

The Chinook family of dialects is too little known even at the present time, but Boas has made an excellent beginning by filling one of J. W. Powells' *Bulletins of the Bureau of Ethnology*, octavo size, with 'Chinook Texts' gathered by himself. These were all obtained from a gifted man of the tribe, Charles Cultee, who is a true storehouse of aboriginal folk-lore and speaks also the Kathlamet dialect of this same stock. From him Boas obtained eighteen national myths and animal stories, followed by a series of 'beliefs, customs and tales,' with some historical reports. These texts were written down during the seasons 1890 and 1891 at Bay Center, Pacific county, Washington, not very far from the Old Chinook home at the mouth of Columbia River. By a sentiment of grateful remembrance the explorer had the portrait of Cultee placed at the head of the volume which contains 278 pages, and was issued late in 1894 from the Government Printing Office in Washington.

Dr. Boas' scientific alphabet had to be very special and flexible to express the sounds of Chinook, a tongue which people will hardly venture to call sonorous or euphonious, for it abounds in consonantal combinations, and more so at the end of the words than elsewhere. The word-accent is never placed upon the ultima, but always on the penult or ante-penult, and this is the law of the language which made consonantal clusters possible in the *final* syllables. The Shawnee, of the Algonkinian stock, has an opposite law; it has the tendency to emphasize words at the end or ultima, and hence we find vowel elisions and consonantal accumulations in the beginning of the words.

As for the contents of the Chinook stories in which fish, ravens and gulls, cranes, robins and panthers are anthropomorphized extensively and much of the fictive matter is presented in colloquial form, we may state that some are outrageously queer and weird; others reveal a poetic vein beneath many things that seem odd and nonsensical, puerile and childish to us.

What refers to the religion of these natives appears very strange, and many will be prompted to exclaim: "Why! for religion, this is decidedly ungodly!" Indeed, we cannot expect that our religious sentiments, which are half Aryan and half Semitic, could ever agree with those of the red man's tenets, beliefs and inspirations. But our religion is all abstraction and theirs is all nature, life and animism. The religious aspects of the primitive man tolerates nothing that is not based on forms and facts of concrete life. The present reviewer is firmly convinced that any white man's opinion concerning the tendencies pervading Chinook folk-lore and similar products of aboriginal peoples is premature and hence erroneous, unless all the bearings and characteristics of this literature have been assiduously studied. Many of us think it is easy to judge the genuine mental products of the American native from our points of view; on the contrary, it is extremely difficult, and the more we study these products, the more the difficulties increase. A. S. G.

The Life and Traditions of the Red Man. JOSEPH NICOLAR. Bangor, Me., 1893. Pp. 147.

Joseph Nicolar is an Indian of the Penobscot tribe settled on islands in the Penobscot River, Maine, and counting about 400 people. These Indians are quite industrious and inventive; they construct birch bark canoes and manufacture basketry of very neat patterns, which they sell either at the neighboring town of Old Town, or at the watering places of the seaside of the New England coast. The Penobscot Indians adhere to the Roman Catholic faith, which was planted among them in the beginning of the eighteenth century. Mr. Nicolar has made it a life-task to study, publish and propagate the folklore of his own people and in 1893 published to this effect '*The Life and Traditions of the Red Man.*' It is an interesting collection of 147 pages, which for graphic qualities and fluency of style rivals any similar production of the white man. It describes the ancient customs and beliefs, not of the Indian in general, as the title would make us believe, but only of the Abnakis or New England Indians of Algonkin race and language, who are subdivided into Penobscots, Passamaquoddies, Miamecs and St. Francis Indians.

The main figure in these stories is *Gluskap*, their chief deity and lawgiver, who unites with his divine power and oratory the qualities of a clown, liar and deceiver. Several aboriginal religions have their main deities clothed in this same ragamuffin or Falstaff garb, and instances of these are Manabozho or Ninebush—the great Rabbit—of the Ojibwé, Sinti among the Kio-was and Kmukámteh among the Klamaths of Oregon. There is no doubt but that they are deifications of the sun and sky, of the winds and storms, and of the seasons of the year. The name of *Gluskap* is the usual Abnáki term for liar and deceiver, but it is rather difficult to discover his real appellation when Nicolai writes him 'Klos-kur-beh.' The book shows a remarkable effort on the part of an Indian to explain to the white man his peculiar manners and ways in life and religion, and the face of the author, of whom a good portrait is added as frontispiece, shows the earnestness of his purposes. The preface is dated Old Town, Maine, but the book was printed at Bangor.

A. S. G.

Vergleichende Pflanzenmorphologie. Von DR. E. DENNERT. Mit über 600 Einzelbildern in 506 Figuren. 254 Seiten. Verlagsbuch handlung von J. J. WEBER, Leipzig, 1894.

In giving a new science text-book to the world, an author ought to have something valuable to present, in order to fix the attention of the scientific public. Dr. Dennert has attempted to do this, and has succeeded in putting in a clear and forcible way the principles of vegetal morphology. Dr. Dennert in his comparative outline does not claim to have made any new departure, but he wishes to give the laity the fundamental tenets of morphological botany. He hopes that the book may prove a useful repertory to students who desire a compendium on the comparative macroscopic structure of plants.

The book puts in a concise and comprehensive form the essentials of vegetable morphology. Most of the figures are good and new, and give the tyro a fair pictorial representation of a variety of interesting plant structures. The arrangement is, as it should be, scientifically logical. Starting with the cell as the 'unit of

plant life, he unfolds in a short chapter the principal points of vegetable histology. The sections on root, stem and leaf commend themselves for clearness and lucidity. Nothing more could be desired for beginners than the sketch of the leaf presented in Section III. of the book. After a brief summary of the development of leaf forms, he follows with a clear exposition of leaf morphology by treating the subject under the following categories.* Cotyledonary leaves (keim-blätter), scale leaves, especially on rhizomes (nieder-blätter), foliage leaves (laub-blätter) with stipules (neben-blätter), bractse (hoch-blätter, deck-blätter) and floral leaves (blüten-blätter). By leaf arrangement, as distinguished from phyllotaxy or leaf situation, Dr. Dennert would mean the various adaptive positions of the leaf with respect to light, moisture, heat, as also leaf mosaics. The interesting features of metamorphosed leaves, leaf traps, leaf pitchers, leaf thorns and fleshy leaves receive due consideration, as also heterophylly as represented in *Ranunculus aquatilis* and *Platyserium Wallinkii*.

The development, or growth of the leaf from the primordial leaf (primordial blatt) and its parts, the embryological leaf base (blatt grund), and the embryological leaf blade (ober-blatt), presented in closing the discussion of leaves, helps to clear up any difficulty which the student may have as to the morphological conception of a leaf, especially as to the nature of stipules.

Dr. Dennert has attempted to give in one hundred pages (134-234) the morphology and 'biology' of the flower and fruit, and has, therefore, only succeeded in giving a mere outline of this topic of absorbing interest. One might wish that the author had enlarged upon the adaptive arrangements of flowers in relation to insect visitation, but Dr. Dennert doubtless left this subject, wisely, for exposition by the individual teacher.

The book, however, as a whole, is to be commended to those who desire to obtain in a short time a general knowledge of plant morphology.

JOHN W. HARSHBERGER.

UNIVERSITY OF PENNSYLVANIA.

* The German terms are given, because there seems to be considerable confusion among students, as to the exact English equivalents.

SCIENTIFIC JOURNALS.

BOTANICAL GAZETTE, AUGUST.*

Synopsis of the North American Amaranthaceæ, III.: EDWIN B. ULIN and WM. L. BRAY. An enumeration of the North American species of this order, with synonymy and remarks upon the recognized species and varieties, together with descriptions of new ones. The genera *Fratichia*, *Gossypianthus*, *Guilleminia*, and *Cladotrix* are treated in this installment. *Fratichia interrupta cordata*, *Gossypianthus lanuginosus Sheldoni* and *Guilleminia densa aggregata* are described as new.

Notes from my Herbarium, III.: WALTER DEANE. In this note Mr. Deane describes his methods of mounting plants. As his herbarium is remarkable for the beauty of the specimens his advice on these matters is especially valuable.

Some Euphorbiaceæ from Guatemala: JOHN P. LOTSY. The last representatives of this order from Guatemala acquired by Capt. John Donnell Smith are here enumerated by Dr. Lotsy. *Euphorbia rubrosperma*, *E. microappendiculata*, *E. leucocephala*, *E. chamæpeplodes*, *Croton eluterioides*, *C. Guatemalensis* and *Tragia Guatemalensis* are described as new. On two double plates three of these new species are figured.

Vegetal dissemination in the genus Opuntia: J. W. TUOMEY. Professor Tuomey calls attention to the fact that the persistency with which these cactuses retain their moisture fits them for vegetal dissemination. The prostrate flat-jointed forms spread by rooting where they touch the ground and having the older parts die away, while the cylindrical erect forms have barbed spines by means of which their joints are transported. Few depend upon seed dissemination.

A study of some Anatomical Characters of North American Gramineæ: TH. HOLM. In this paper the author concludes the examination of the species of *Leersia* and enumerates the anatomical characters of the leaves by which they can be discriminated.

Daniel Cady Eaton: GEORGE E. DAVENPORT. This is a short but appreciative biographical sketch of the late Professor Eaton, by one who has long been associated with him in the critical

*Issued August 15, 1895. 40 pp., 5 pl.

study of the ferns. A portrait accompanies the sketch.

The Nomenclature Question: A Further Discussion of the Madison Rules: B. L. ROBINSON. Dr. Robinson replies to Mr. Coville's criticisms in the July number and again vigorously attacks the doctrine of 'the rejection of the homonyms.'

Among *Briefer Articles* is one describing a new genus of Umbellifere from Mexico, which the authors, Dr. John M. Coulter and Mr. J. N. Rose, dedicate to Mr. Walter Deane under the name of *Deanea*, with two species, *D. nudicaulis* and *D. tuberosa*; and one by Dr. Trelease, asking for information in regard to the distribution of our species of pignuts. An *Editorial* vigorously defends the *Gazette* against the charge, by an anonymous correspondent of the *Journal of Botany*, of suppressing free discussion of the nomenclature question. Under *Current Literature* Mr. Charles Robertson reviews MacLeod's 'Fertilization of Flanders Flowers,' and the editors notice a new issue in Ostwald's 'Klassiker der exakten Wissenschaften.' Two pages of *Notes and News* conclude the number.

PSYCHE, SEPTEMBER.

W. S. BLATCHLEY continues his account of the winter insects of Vigo county, Ind., adding 26 more species of Hepteroptera. G. B. King finds from repeated observations of frozen nests that *Formica obscuripes* does not retreat into the lower parts of the nest in winter, but remains practically in all parts excepting close to the surface, though, of course, wholly inactive; some of the parasites are noticed. In a supplement, T. D. A. Cockerell describes a couple of new bees and some new Coccidæ and adds a note on a Mutillid which 'as it runs over the ground . . . looks extremely like a bit of thistle down blown by a gentle breeze.'

NEW BOOKS.

Tables for the Determination of Common Minerals.

W. O. CROSBY. Third edition rewritten and enlarged. Boston, The Author. 1895. Pp. 106.

Fishes, Living and Fossil. Bashford Dean. Columbia University Biological Series III. New York, Macmillan & Co. 1895. Pp. xiv+300.

SCIENCE

NEW SERIES.
VOL. II. No. 37.

FRIDAY, SEPTEMBER 13, 1895.

SINGLE COPIES, 15 CTS.
ANNUAL SUBSCRIPTION, \$5.00.

GUSTAV E. STECHERT'S

Recent Importation of Scientific Books.

BECKERT, TH. and DR. ALBANO BRAND. Hüttenkunde. Mit 235 in den Text gedruckten Figuren. 765 Seiten. gr. 8^o. Mk. 20.

BEHRENS, H. Anleitung zur mikrochemischen Analyse. Mit einem Vorwort von Prof. S. Hoogewerf in Delft. 224 Seiten mit 92 Figuren in Text. 8^o. Mk. 6.

BIEDERMANN, W. Elektrophysiologie. 1^{te} Abtheilung. Mit 136 Abbildungen. 440 Seiten: 8^o. Mk. 9.

BORCHERS, DR. W. Elektro-Metallurgie. Die Gewinnung der Metalle unter Vermittlung des elektrischen Stromes. 2^{te} verm. v. völlig umgearb. Auflage. 1^{te} Abtheilung, mit 87 Abbildungen. 160 Seiten. gr. 8^o. Mk. 6^{oo}.

BUSCHAN, GEORG. Vorgeschichtliche Botanik der Cultur- u. Nutzpflanzen der alten Welt auf Grund prähistorischer Funde. 268 Seiten. 8^o. Mk. 7^{oo}.

DAMMER, DR. O. Handbuch der chemischen Technologie. Unter Mitwirkung von Direktor Th. Beckert, Dr. Bender, Dr. Benedikt, Dr. Börnstein u. A. herausgegeben. 2^{ter} Band. Mit 235 in den Text gedruckten Figuren. gr. 8^o. Mk. 20.

DELAGE, YVES. La structure du protoplasma et les théories sur l'hérédité et les grands problèmes de la biologie générale. 878 pages. gr. 8^o cloth. frs 24^{oo}.

DETMER, DR. W. Das pflanzenphysiologische Praktikum. Anleitung zu pflanzenphysiolog. Untersuchungen für Studierende u. Lehrer der Naturwissenschaften, sowie der Medicin, etc. 2^{te} völlig neubearbeitete Aufl. Mit 184 Abbildungen. 456 Seiten. 8^o. Mk. 9.

FOREL, DR. AUGUST. Der Hypnotismus, seine psycho-physiologische medicinische, strafrechtliche Bedeutung und seine Handhabung. 3^{te} verb. Aufl. mit Adnotationen von Dr. O. Vogt. 223 Seiten. gr. 8^o. Mk. 5.

FRANK, DR. A. B. Die Krankheiten der Pflanzen. Ein Handbuch für Land u. Forstwirthe, Botaniker, etc. Erster Band, Die durch anorgan. Einflüsse hervorgerufenen Krankheiten. Mit 34 Holzschnitten. 2^{te} Aufl. 344 Seiten. 8^o. Mk. 6^{oo}.

HIS, WILH. Die anatomische Nomenclatur. Nomina anatomica, Verzeichniss der von der anatomischen Gesellschaft auf ihrer 9. Versammlung in Basel angenommenen Namen. Mit 30 Abbildungen im Text und 2 Tafeln. 180 Seiten. Mk. 7^{oo}.

HOUDAILLE, F. Météorologie agricole. 204 pages cloth. fr. 3.

JAHRBUCH DER ELEKTROCHEMIE. Berichte über die Fortschritte des Jahres 1894. Im wissenschaftlichen Theile bearbeitet von Dr. W. Nernst. Im technischen Theile bearbeitet von Dr. W. Borchers. 1^{er} Jahrgang. 274 Seiten. gr. 8^o. Mk. 10.

JERUSALEM, WILH. Die Urtheilsfunction. Eine psychologische und erkenntniskritische Untersuchung. 269 Seiten. Mk. 6^{oo}.

LOEWY, DR. A. Untersuchungen über die Respiration and Circulation bei Aenderung des Druckes und des Sauerstoffgehaltes der Luft. Mit 5 Curventafeln im Text. 155 Seiten. gr. 8^o. Mk. 4.

MEYER, DR. ARTH. Untersuchungen über die Stärkekörner der höheren Pflanzen. Mit 9 Tafeln u. 99 Text-Abbildg. 318 Seiten. gr. 8^o. Mk. 20^{oo}.

NIEDENZU, DR. FRANZ. Handbuch für botanische Bestimmungsübungen. Mit 15 Figuren im Text. 351 Seiten. 8^o. Mk. 4.

SCHAEFFER, DR. KARL. Suggestion und Reflex. Eine Kritisch-experimentelle Studie über die Reflexphänomene des Hypnotismus. Mit 6 Tafeln in Lichtdruck und 11 Abbildungen im Text. 113 Seiten. gr. 8^o. Mk. 6^{oo}.

SCHMIDT, DR. ALEX. Weitere Beiträge zur Blutlehre. Nach des Verfassers Tode herausgegeben. 247 Seiten. 8^o. Mk. 7.

SCHWARTZE, TH. Die Lehre von der Electricität und deren praktische Verwendung. Mit 153 in den Text gedruckten Abbildungen. 543 Seiten. 8^o. Mk. 10^{oo}.

STEINHARDT, DR. EUGEN. Kurzes Lehrbuch der Chemie zum Gebrauch an Schulen und zur Selbstbelehrung. Zwei Teile. Erst. Teil; Anorganische Chemie. 418 Seiten. 8^o. Mk. 6^{oo}.

VAN BIERVLIET, J. J. Elements de psychologie humaine. Cours professé à l'université de Gand. Avec 34 figures dans le Text. 317 pages. frs 8.

ZEITSCHRIFT FÜR ANGEWANDTE Mikroskopie herausgegeben von G. Marpmann. Monthly. 1^{ter} Band 1^{tes} Heft. Per year, \$2.75.

ZEITSCHRIFT, Geographische, Herausgegeben von Dr. Alfred Hettner. 1^{er} Jahrg. 1^{es} Heft. Per year (12 N^{os}) \$4^{oo}.

ZIMMERMANN, DR. A. Das Mikroskop. Ein Leitfaden der wissenschaftlichen Mikroskopie. Mit 231 Figuren im Text. 334 Seiten. gr. 8^o. Mk. 9.

ZITTEL, KARL A. VON. Grundzüge der Paläontologie (Paläozoologie). Mit 2048 in den Text gedruckten Abbildungen. 971 Seiten. gr. 8^o. ½ mor. Mk. 25^{oo}.

GUSTAV E. STECHERT,

810 Broadway, New York.

Macmillan & Co.'s New Publications

NEW VOLUME OF THE

Columbia University Biological Series.

Edited by HENRY FAIRFIELD OSBORN, *Da Costa Professor of Biology in Columbia College.*

Fishes, Living and Fossil.

An Outline of their Form and Probable Relationship.

By BASHFORD DEAN, Ph. D. Columbia, *Instructor in Biology, Columbia College.*
With Illustrations from the Author's original Pen Drawings. 8vo, cloth, \$2.50 net.

ALREADY PUBLISHED IN THE SAME SERIES.

From the Greeks to Darwin. The development of the evolution idea. By HENRY FAIRFIELD OSBORN, Sc. D. Princeton, *Da Costa Professor of Biology in Columbia College.* 8vo, cloth, \$2.00 net.

Amphioxus and Ancestry of the Vertebrates. By ARTHUR WILLEY, B. Sc. Lond., *Tutor in Biology, Columbia College, Balfour Student of the University of Cambridge.* With Illustrations. 8vo, cloth, \$2.50 net.

NEW VOLUME.

Columbia University Press.

Atlas of the Fertilization and Karyokinesis of the Ovum.

By EDMUND B. WILSON, Ph. D., *Professor of Invertebrate Zoology in Columbia College*, with the cooperation of EDWARD LEAMING, M. D., F. R. P. S., *Instructor in Photography at the College of Physicians and Surgeons, Columbia College.* Illustrated with 40 figures photographed from nature by Dr. Leaming, from the preparations of Professor Wilson at an enlargement of one thousand diameters, and mechanically reproduced by the gelatine process without retouching, by Edward Bierstadt of New York. The plates are accompanied by an explanatory text, giving a general introduction to the subject for the use of students and general readers, a detailed description of the photographs, and over sixty text-figures from camera-drawings. 8vo, cloth, \$4.00 net.

Hertwig.—The Cell: Outlines of General Anatomy and Physiology.

By DR. OSCAR HERTWIG, Professor Extraordinarius of Anatomy and Comparative Anatomy, Berlin. Translated by M. CAMPBELL and Edited by HENRY JOHNSTONE CAMPBELL, M. D., Assistant Physician to the City of London Hospital for the Diseases of the Chest, etc. With 165 Illustrations. 8vo, cloth, pp., \$3.00, net.

Lindsay.—An Introduction to the Study of Zoology.

By B. LINDSAY, C. S. of Girton College, Cambridge. With 124 Illustrations and Diagrams. Pp. xix+356, 12mo, cloth, \$1.60 net.

Cooke, Shipley and Reed. Molluscs and Brachiopods.

By REV. A. H. COOKE, M. A., Fellow of King's College, Cambridge; A. E. SHIPLEY, M. A., Fellow of Christ's College, Cambridge; and F. R. C. REED, B. A., Trinity College, Cambridge. Illustrated. *Cambridge Natural History.* 8vo, cloth, pp. 535, \$3.25 net.

"Written in the true spirit of the Alpine Climber."

The Alps from End to End. By SIR WILLIAM MARTIN CONWAY. With 100 Illustrations by A. D. MCCORMICK. Large demy, 8vo, cloth, \$7.00.

The Rural Science Series.

Edited by L. H. BAILEY. New Volume.

King.—The Soil. Its Nature, Relations and Fundamental Principles of Management. By F. H. KING, Professor of Agricultural Physics in the University of Wisconsin. 16mo, cloth, 75 cents.

Jackson.—The Great Frozen Land. Narratives of a Winter Journey across the Tundras and a Sojourn among the Samoyeds. By GEORGE F. JACKSON, Fellow of the Royal Geographical Society and Leader of the Jackson-Harnsworth Polar Expedition. With Illustrations and Maps. Edited from his Journals by ARTHUR MONTEFIORE. 8vo, cloth, pp. xviii + 297, \$4.50.

Wright.—Birdcraft. A Field Book of Two Hundred Song, Game and Water Birds. By MABEL OSGOOD WRIGHT. With numerous full-page Plates containing 128 Birds in the Natural Colors, and other Illustrations. 8vo, bound in linen, \$3.00 net.

"An Arctic Adventure."

Ice-Bound on Kolguev. By AUBYN TREVOR-BATYEE, F. L. S., F. Z. S., etc. With numerous Illustrations and Drawings, and 3 Maps. Large 8vo, cloth, gilt top, \$7.00.

MACMILLAN & CO., 66 Fifth Avenue, New York.

SCIENCE

EDITORIAL COMMITTEE: S. NEWCOMB, Mathematics; R. S. WOODWARD, Mechanics; E. C. PICKERING, Astronomy; T. C. MENDENHALL, Physics; R. H. THURSTON, Engineering; IRA REMSEN, Chemistry; J. LE CONTE, Geology; W. M. DAVIS, Physiography; O. C. MARSH, Paleontology; W. K. BROOKS, Invertebrate Zoölogy; C. HART MERRIAM, Vertebrate Zoölogy; S. H. SCUDDER, Entomology; N. L. BRITTON, Botany; HENRY F. OSBORN, General Biology; H. P. BOWDITCH, Physiology; J. S. BILLINGS, Hygiene; J. MCKEEN CATTELL, Psychology; DANIEL G. BRINTON, J. W. POWELL, Anthropology.

FRIDAY, SEPTEMBER 13, 1895.

CONTENTS:

| | |
|---|-----|
| <i>The Springfield Meeting of the American Association for the Advancement of Science:</i> JAS. LEWIS HOWE..... | 313 |
| <i>The Relation of Engineering to Economics:</i> WILLIAM KENT..... | 321 |
| <i>John Adam Ryder:</i> HARRISON ALLEN..... | 334 |
| <i>Reports of International Meteorological Meetings:</i> A. LAWRENCE ROTCH..... | 336 |
| <i>The American Chemical Society.....</i> | 337 |
| <i>Scientific Notes and News:—</i> | 338 |
| <i>Railway Speed in Great Britain:</i> R. H. T. The Royal Society of New South Wales; <i>General.</i> | |
| <i>Correspondence:—</i> | 342 |
| <i>Winds and Ocean Currents:</i> W. M. DAVIS. <i>Corrections:</i> THEO. GILL. <i>Bolometric Investigations:</i> WILLIAM HALLOCK. | |
| <i>Scientific Literature:—</i> | 344 |
| <i>Beyer's Growth of U. S. Naval Cadets:</i> FRANZ BOAS. <i>Meyer's Untersuchungen über die Stärkekörner:</i> EMILY L. GREGORY. | |

MSS. intended for publication and books, etc., intended for review should be sent to the responsible editor, Prof. J. McKeen Cattell, Garrison on Hudson, N. Y.
Subscriptions and advertisements should be sent to SCIENCE, 41 N. Queen St., Lancaster, Pa., or 41 East 49th St., New York.

XLV. MEETING OF THE AMERICAN ASSOCIATION FOR THE ADVANCEMENT OF SCIENCE, SPRINGFIELD, MASS., AUG.

28th-SEPT. 4th, 1895.

IN 1859 the American Association assembled for its thirteenth meeting in Springfield. After the lapse of thirty-six years the Association has again met in the metropolis of western Massachusetts, this time for its forty-fourth annual gathering, five meetings having been passed on account of the Civil War.

Geographically, Springfield is well located

for a place of meeting, being within easy reach of a large proportion of the members of the Association. For some reason, perhaps, the unusually late date of holding the meeting, the hopes of officers and local committee as to attendance were not realized, it having been the smallest meeting held in the eastern section of the country since that of Saratoga in 1879, and having but slightly exceeded the meetings held in the West. The number of members registered was hardly double that of the earlier Springfield meeting, when 180 were present.

The uncertainty until a late date as to where the meeting would be held, it having been hoped that the railroads would make satisfactory rates to San Francisco, may also have contributed to the smallness of the meeting.

But if the attendance was not what might have been wished, the arrangements by the local committee have rarely been better made. Outside of a University town it is rarely possible to have all the audience rooms in one building, but at Springfield all were in such close proximity that little inconvenience was experienced in going from section to section and to the offices and reception rooms. Every convenience was provided for the members, and the courtesies of the citizens of the city are worthy of special mention. It is, however, unusual that the immediate vicinity of the place of meeting is so meagerly represented among

the members. Of the whole number registered, only 15 were from the city of Springfield and hardly more than half a hundred from the entire State of Massachusetts; more than half of these, too, were elected at the present meeting.

While these strictures must in fairness be passed upon the meeting, the work in the individual sections was probably above the average. The number of papers presented—over two hundred—was very large and many of them were of unusual value and interest. This was particularly true in the Sections of Chemistry and Anthropology, and members were heard to characterize the meeting as far as regarded these sections as the most helpful and best ever held. In the Chemical Section this was due to the labors of the Vice-President and Sectional Committee in preparing the program long in advance of the meeting. In this connection it may be said that of the 184 new members elected 40 belong to section C, and 21 out of 58 fellows elected at the Springfield meeting are members of the the same section. At the same time the American Chemical Society is by far the largest (over 900 members) and perhaps the most active of the Affiliated Societies. In this case it seems as if the Affiliated Society is directly conducive to the prosperity of the Section of the Association. The opening session of the Association was held in the Y. M. C. A. Hall on Thursday morning. In calling the meeting to order the Permanent Secretary, Prof. F. W. Putnam, read a letter from the President, Dr. D. G. Brinton, announcing that owing to the continued serious illness of his wife it was impossible for him to return from Europe in time for the meeting. In Dr. Brinton's absence, the Senior Vice-President, Prof. Wm. H. Brewer, of New Haven, was called to the chair, and referring in a few well-chosen words to the labors of the President-elect in his well-known determinations of

the composition of water, introduced Prof. Edward W. Morley, of Cleveland, as President of the forty-fourth meeting of the Association. After an invocation by Rev. Bradley Gilbert addresses of welcome were delivered by ex-Lieutenant-Governor W. H. Haile, and Mayor Charles L. Long. This latter address, contrasting well the periods at which the two Springfield meetings were held, was as follows:

More than a third of a century has passed away since this Association last met in this city, on the 3d day of August, 1859, for the purpose of holding its 13th gathering. Prof. Stephen Alexander, that distinguished astronomer whose writings attracted the attention of scientific scholars of this country and of other lands, presided at the meeting. The political and scientific changes which have taken place during the period that has passed have been many, and they have been as remarkable as they have been numerous.

When that convention assembled, human slavery was a legalized institution in the Southern States, and the great question of its extension into the Territories and of their admission into the Union cursed with its blight agitated the people. Two months had scarcely passed after the Association adjourned, before the country was convulsed with excitement over the insurrection at Harper's Ferry, and within two years the storm which had for so long been gathering and which was to settle forever the great questions of State rights and of human slavery in this country broke with terrific fury upon our beloved land, drenching it in fraternal bloodshed and in a conflict unequal in its magnitude and unsurpassed in the importance of the results achieved.

No doubt the learned men who assembled at that gathering were proud of the success which had thus far drowned scientific investigation, and gloried in the great ad-

vance which had been made. But so great have been the discoveries which have followed, and so wonderful have been the changes which these discoveries have wrought, that we can hardly appreciate that many of the great scientific truths of to-day were but cautiously advanced theories at that time.

It was during the year preceding that meeting that the paper of Wallace 'on the tendency of varieties to depart indefinitely from the original type' and Darwin's paper 'on the tendency of species to form varieties' were read, simultaneously, before the Linnæan society. On the first of October following that meeting Darwin published his 'Origin of Species,' which more than a decade later caused the French Academy to reject him as a candidate for membership by a vote of more than two-thirds, one of its members declaring that the 'Origin of Species' was 'a mass of assertions and absolutely gratuitous hypotheses, often evidently fallacious.'

Truly, 'the stone which the builders refused is become the headstone of the corner,' for the doctrines of Darwin's work are now recognized and accepted by the learned and scientific of the civilized world; and evolution, which was for years scorned and rejected not only by the great majority of the scientific, but by pretty much everybody whose views upon the subject were entitled to weight, is now almost universally accepted.

During this period the doctrine of spontaneous generation received the aggressive attention of scientists. The views of the learned Pasteur, which were opposed to this doctrine, were contested, and were supposed to have been refuted by the experiments of Wyman. The theory of spontaneous generation is no longer accepted, but out of the agitation which it created, was born the new science of bacteriology.

Indeed, during the period of which I am

speaking, the progress in geological, zoölogical, physiological and astronomical science, in chemistry and in physics, has been marvellous. The wonderful development and utilization of electric forces, which forms such a marked demonstration of the value of scientific research, was not then dreamed of. Even the Atlantic Cable had not been successfully laid, and the results of the wonderful inventions of Edison, of Bell and of many others of the great discoverers and inventors of the electrical world were not for a moment contemplated.

The doctrine of the antiquity of man, which sought to place and which now places his origin far back beyond the period of 6000 years, which was then zealously contested, is now not only adopted by scientists, but is accepted complacently by all the well-informed without any shock to their religious feelings.

These great advances, which have entertained, enlightened and improved the mind, and added greatly to the comfort, happiness and welfare of mankind, are the result of investigation and study by men such as those of you whose lives are devoted to scientific research and who are here assembled as an association under a constitution proclaiming its object to be: "By periodic and migratory meetings, to promote intercourse between those who are cultivating science in different parts of America, to give a stronger and more general impulse and more systematic direction to scientific research, and to procure for the labors of scientific men increased facilities and a wider usefulness."

You have assembled in a city which has sprung from one of the earliest settlements in this Commonwealth. Here, 260 years ago, the rude cabins of the first white settlers were erected. Here our Puritan ancestors found in large numbers, contented and happy in their savage freedom and ignorance, the American Indian, from whom

they obtained by purchase the land upon which our city is built and with whom, for a period of 40 years, they lived in interrupted peace.

Here, as declared in the first of the articles adopted for their future government, they laid the foundation of their future growth and prosperity on the principles of the Christian religion; and here, as a result of those principles, the industry and honesty of our predecessors and the aggressive qualities of our people, we have, to-day, a well-governed, a prosperous and beautiful city, surrounded by natural scenery which excites the admiration of all lovers of nature; a city which, in population, in trade and in its industries is deservedly recognized as the metropolis of western Massachusetts.

I am greatly honored in being the representative of such a city, and as its representative in extending to you a cordial welcome to our borders, to an association with our people, to an examination of our institutions and to such entertainment as we may be able to provide for you; and I assure you that by your presence our citizens appreciate that they are greatly honored by reason of your high standing as individuals, your professional attainments, and the reputation of your Association, whose illustrious work in the past will be, I am sure, excelled by the results which will crown its labors in the future.

Replying to ex-Lieutenant-Governor William H. Haile, President of the Local Committee, and His Honor the Mayor, Charles L. Long, who had welcomed the Association, Mr. Morley said:

GENTLEMEN: That which you say to us of the beauty of Springfield and of the scenery of this fertile valley commands our cordial assent. We listen with delight to the survey of the general progress of science since our last meeting in your city, which you state with so much fairness, and with

so much justice and so much breadth of view. But best of all are the words of hearty and generous welcome which are so grateful to us, because they assure us of a profitable meeting and promise us delightful intercourse with your citizens.

Massachusetts is the last place on the face of the earth where this Association could possibly be made to feel like a stranger and an alien. It was an act of your Legislature which incorporated us. Of our forty-two Presidents, Massachusetts can fairly claim as her citizens not less than seven, or one-sixth of the whole number. Almost from time immemorial one Permanent Secretary after another has been elected from Massachusetts. We have met at Cambridge, at Springfield, at Salem, at Boston and again at Springfield.

Let me interrupt for a moment my reply to your welcome. Some of us, for whom the backward view covers the larger part of the visible heavens, would recall something of our meeting here in 1859. There are now on our list the names of twenty-one who were members of our Association at that time. Its President was that Professor Alexander, of whom the President of the Local Committee has already spoken. The Vice-President (there was but one), was a most distinguished citizen of Massachusetts, who was the first President of the Society which was the parent of our own, known all over the world for his masterly labors in geology, Dr. Edward Hitchcock, of Amherst. The General Secretary and the Permanent Secretary were Professors Joseph Lovering, of Cambridge, and William Chauvenet, of St. Louis.

Of those who became members of this Association at our Springfield meeting, eighteen have maintained their membership to the present time or to their decease. But four of these are living. Professor G. F. Barker is known to us all; some of us think his compendium of physics is the best

in the English language. Dr. Samuel H. Scudder is known for his work on the bibliography of science, and for his many labors in entomology; this Association has published a memoir of his on fossil butterflies. Professor Henry A. Ward is again here making an exhibit of mineralogical and geological specimens, which is a source of much pleasure to many of our own number and of the public. Of those whom we have lost I may mention Henry B. Mason, of Troy; Lewis M. Rutherford, of New York, and James Craig Watson, of Ann Arbor.

The number of our members in attendance at that meeting was large; we may be sure that when such officers presided and such men became members, the meeting cannot but have been a successful and profitable one.

Your welcome was especially grateful to us, because it exhibited an appreciative interest in us and in our work. Such an appreciative interest has been exhibited in other ways. On eight dates during the summer I have been where I read a Springfield morning paper. Four of these papers contained articles, of at least a half a column, written with dignity, with adequate information, not without literary graces of style, which were devoted to this Association; therefore, in the judgment of a practiced editor, many of those who read your daily papers have some intelligent interest in our Association, its history, its object, its methods, in the history of our sister Associations in other countries.

Your words of welcome express the same appreciative interest; they confirm the same favorable impression we have received, and fill us with pleasurable anticipations.

We know something of Massachusetts, and of what sort of welcome we might reasonably expect. We know of Massachusetts, though not many of us are its citizens or its children. In the intention of its

founders, our Association includes the whole of this continent; in accomplished fact our membership represents perhaps every State of this Union and every province of the great Dominion north of us, and a few from countries or islands to the south of us. Many of us have, therefore, grown up under other influences than those of Massachusetts. We come from other strains of colonization. We owe allegiance to other local institutions. We have learned to revere other local traditions.

But we all cordially agree in saying that, in all those things in which the citizens of a Commonwealth ought to feel the highest pride, Massachusetts is unsurpassed. No contributions to political thought have been greater or better than hers; no moulding of political or social institutions has been wiser than hers; nowhere on the continent has literature touched a higher level than on her shores or her western hills; nowhere has high thinking been better combined with living made subservient to the intellectual life.

We see these things; we admire, but we do not wonder, for we know the stock which first settled Massachusetts Bay. Putting religion in a place, some think, too high for mortal powers, they came from school and college in the old world, and brought to the new a profound sympathy with learning and scholarship and literature. These men, their spirit, their foundation of universities, their keen intellectual life have made this Commonwealth one whose guests we are proud to be, sure of welcome, sure of *appreciative* welcome, which receives us for what we are.

We are an association for the advancement of science. Some of us advance science chiefly by expressing our interest in it. Some of us, burdened with much teaching, find in that the limit of our opportunities. But some of us try to enlarge the borders of science and to add to the world's stock

of knowledge. These last ought to be considered as the more important part of our society and as the proper index to its character.

Now, the advancement of science ministers chiefly to purely intellectual wants. Science is not the apple tree nor the vine, bearing fruit for the body. It is the elm or the lily; carefully nurtured, highly prized, because it ministers to higher necessities, to intellectual or æsthetic wants. Of course, many purely scientific discoveries have become the basis of inventions which have conferred enormous material benefits; some value science chiefly or wholly because of the promise of further material advantages; they esteem the elm because sometime it may perhaps support the vine. But we, who love science and give to it much labor and weariness, value it chiefly because of the intellectual benefits which it confers on our race. And in this ancient Commonwealth we feel that you value every source of intellectual uplifting and intellectual inspiration. We think, and I am sure so do you, that this world is a better place for men to live, now that we know its size, even if we can make no material profit from the knowledge. We think, with you, that this continent is a better home for intellectual beings, now that the history of its formation has been made out by the combined labors of so many eminent geologists, and has been told with such a wealth of learning and such skill of exposition by one of our past Presidents, who has been taken from us since we last met, not till he had completed his work. The knowledge of the distance of the sun makes no one richer or warmer, but it makes some of us happier, by satisfying the ennobled and ennobling curiosity which seeks to learn all which is now unknown.

So we who are fascinated with science justify our devotion to it by the intellectual benefits which our devotion confers on our

fellow men. So we ask you to receive us, not as engineers, promising new structures or flying ships; not as inventors, creating new sources of income and new comforts; not as ethical teachers, for science cannot change human natures or the social order; not even as those who would make two ears of corn grow where one grew before; but as those who would make two lilies grow for one in the garden of the Nation's intellectual life.

We wish we could make some return for your generous welcome, in kind, in any way; but we cannot. We can only thank you; we thank you again, and again.

On the afternoon of Thursday the addresses of the Vice-Presidents were delivered, and in the evening the Presidential address of Dr. D. G. Brinton, on the 'Aims of Anthropology,' was read in the Court Square Theater by the General Secretary. As these addresses are published in full in the columns of SCIENCE, no further reference is made to them.

Three public lectures, complimentary to the citizens of Springfield, were given during the week. On Friday evening Professor Wm. M. Davis, of Harvard University, lectured on 'The Geographical Development of the Connecticut Valley,' a large and evidently appreciative audience following with interest the story of the valley, and enjoyed the accompanying stereopticon views.

On Tuesday evening the City Hall was almost filled to hear Mr. Cornelius Van Brunt's lecture on 'The Wild-flowers of the Connecticut Valley,' and more especially to see the beautiful floral photographs, exquisitely colored by Mrs. Van Brunt, projected by the stereopticon. The flowers, which comprised our common favorites, had evidently been photographed against an absolutely black background, and then the positive lantern slide colored with great delicacy and fidelity to nature. The flowers

stood out upon the screen with a beauty that can hardly be exaggerated; they were most enthusiastically received by the audience.

On Wednesday afternoon, Professor A. S. Bickmore lectured on the 'Illustrative Method of Teaching Geography and Zoölogy at the American Museum of Natural History, in New York City.' This lecture, like its predecessors, was illustrated by beautiful stereopticon views.

Evident emphasis was laid upon the social side of the Springfield meeting. While unquestionably many of the members attend almost exclusively on account of the papers and discussions of the meetings of the several sections, there is a large number who would lay equal stress on the value of the gathering in bringing together socially specialists in very varied fields of knowledge, and of giving them opportunities for interchange of ideas; the specialist needs more breadth and he gains it by contact with those outside of his immediate field. The importance of this as an aim of the Association is often overlooked, but should not be. On Wednesday evening the Association was invited to a reception at the new Art Museum, the doors of which were that night for the first time opened to the public. The building is a beautiful one and a fitting place for housing the collection which in a number of departments is of great value. On Thursday evening, at the conclusion of the Presidential address, the Ladies' Reception Committee gave a reception to the Association at the City Hall. The hall was tastefully and appropriately decorated, the music by two orchestras well selected and rendered, the collation thoroughly appreciated, and the efforts of the committee in charge to make the occasion enjoyable to all present were eminently successful. On Monday, late in the afternoon, lawn receptions were given to the several sections by ladies of Springfield, which were largely attended and enjoyed.

The whole day on Saturday was as usual devoted to excursions in the vicinity of Springfield. The college party, which included most of the members present, left early in the morning for Amherst, a small number however leaving the party at Holyoke in order to visit Mt. Holyoke College at South Hadley. Most of the party kept on to Amherst, where they were taken in carriages to either Amherst College or the Agricultural College, as they wished. Several hours were spent in examining the buildings and collections. At Amherst College much attention was attracted by the new chemical and physical laboratory erected under the direction of Professors Hains and Kimball, and by the fossil footprints collected by President Edw. Hitchcock. At the Agricultural College the Insectary, one of the three in existence, was considered the most notable feature. From Amherst the party went to Northampton, where a collation was served at the town hall by the citizens of the place. Unfortunately at this time the rain which had threatened all the forenoon now began, and somewhat interfered with the enjoyment of the afternoon. The party visited Smith College in carriages and many of them went to the numerous places of interest in the suburbs of Northampton. In spite of the weather, the day was one of much pleasure and profit to the participants in the excursion. Sunday, though quietly spent, was not devoid of scientific interest to the members of the Association. Several pulpits were filled by visiting members and a number of sermons on subjects of scientific bearing were preached in various churches. In the evening a union meeting was addressed by a number of members of the Association, and in the afternoon the usual Association prayer meeting was held at the Y. M. C. A. rooms. Returning to the more direct work of the Association, each morning a general session was held at ten o'clock, and the

final session was held on Wednesday evening, September 4. At these general sessions all business transacted by the Council was announced and their recommendations were considered by the Association. The more important items of business should be enumerated. After a prolonged discussion on the recommendation of the Council to change the name of Section I from Economic Science and Statistics to Sociology, the Association voted that the Section should be called *Economic and Social Science*. The Association declined to form a Section of Geography, letting Section E remain *Geology and Geography*.

Grants were made from the Research Fund as follows: \$100 to Professor William A. Rogers, of Colby University, for continuing the work of Professor Morley and himself on the measurement of the expansion of metals by means of the interferential comparator; \$100 to support a table at the Marine Biological Laboratory at Wood's Holl, the same to be under the direction of Vice-Presidents of the sections of zoölogy and of biology ex-officio, and of Professor C. O. Whitman, of the University of Chicago; \$250 towards the support of the International Bibliographical Bureau at Zurich, Switzerland. This bureau is the result of the work of an American zoölgist, Dr. H. H. Field, and aims to prepare a current subject index of the publications in zoölogy. Owing to a financial stringency in the treasury of the Association it was felt necessary to curtail grants and other expenditures, and in view of this a number of members and friends subscribed several hundred dollars for the needs of the Association, and the hope was expressed that others will make this sum up to at least one thousand dollars.

It was decided to deposit the Library, which consists of several thousand volumes, mostly exchanges, with the University of Cincinnati, where it will be available to the

members and fellows for direct consultation, or by mail, or express. The University of Cincinnati has offered to keep it in their new building and to bind within the next five years all the volumes, nearly three-fourths, which are now unbound. A card catalogue of the Library will be made, and it is hoped that the members and fellows will utilize the valuable publications in the Library. Professor J. U. Lloyd, of Cincinnati, and his brother have also in this connection offered to make their Botanical and Pharmaceutical Library accessible to the Association. This Library is probably the most complete on the continent in these subjects and is being constantly added to.

Professor Benjamin Apthorp Gould, of Cambridge, and Professor Rudolph Leuckart, of Leipzig, were elected to Honorary Fellowship in the Association.

The Sectional Committees of each Section were instructed to make efforts to have the program for their respective sections for the next meeting prepared as far as possible in advance, and the provisional programs will be distributed to the members at least a month before the time of meeting. It was felt that the experience of the Section of Chemistry showed that this would add much to the interest and profit of the meeting.

The election of officers for the meeting of 1896 resulted as follows:

President, Edward D. Cope, of Philadelphia.

Vice-Presidents, A. Mathematics and Astronomy, Wm. E. Story, of Worcester, Mass. B. Physics, Carl Leo Mees, of Terre Haute, Ind. C. Chemistry, W. A. Noyes, of Terre Haute, Ind. D. Mechanical Science and Engineering, Frank O. Marvin, of Lawrence, Kans. E. Geology and Geography, Ben. K. Emerson, of Amherst, Mass. F. Zoölogy, Theodore N. Gill, of Washington, D. C. G. Botany, N. L. Britton, of New York City. H. Anthropology, Alice C. Fletcher, of Washington, D. C. I. Economic and Social Science, William R. Lazenby, of Columbus, O.

Permanent Secretary (for 5 years from 1894), F. W. Putman, Cambridge, Mass.

General Secretary, Charles R. Barnes, Madison, Wis.

Secretary of the Council, Asaph Hall, Jr., of Ann Arbor, Mich.

Secretaries of the sections, A. Mathematics and Astronomy, Edwin B. Frost, of Hanover, N. H. B. Physics, Frank P. Whitman, of Cleveland, O. C. Chemistry, Frank P. Venable, of Chapel Hill, N. C. D. Mechanical Science and Engineering, John Galbraith, of Toronto, Can. E. Geology and Geography, A. C. Gill, of Ithaca, N. Y. F. Zoölogy, D. S. Kellicott, of Columbus, O. G. Botany, George F. Atkinson, of Ithaca, N. Y. H. Anthropology, John G. Bourke, U. S. Army. I. Economic and Social Science, R. T. Colburn, of Elizabeth, N. J.

Treasurer, R. S. Woodward, New York, N. Y.

Invitations to hold the meeting of next year at St. Paul, Indianapolis, Colorado Springs and Buffalo were presented. Buffalo was selected, partly for the reason that there has come to be a sort of precedent for a meeting at Buffalo every ten years. The Association met at Buffalo first in 1866, the first meeting after the opening of the war; 1876 and 1886 saw the Association again there, and now in 1896 the visit to Buffalo will be repeated. It was also kept in mind that a strong effort is being made to have the British Association meet at Toronto in 1897, and that the west would furnish desirable places for a joint meeting of the two Associations.

Much more debate was occasioned in selecting the date for the next meeting. The meeting of this year, beginning as it did the fifth week in August, was felt to be too late, the early opening of the schools and some colleges preventing the attendance of many teachers. This year the meeting opened on Thursday; sections met on Friday; Saturday was devoted to excursions, and the Sections renewed their meetings on Monday. The break of two days was felt to be detrimental to the interests of the Association. The Council proposed that the first meeting and Vice-Presidential and Presidential addresses be on Monday, leaving four days of continual session for section work, and then at the close Saturday is left for excursions. Many of the members,

however, felt that Tuesday would be the best day for opening, as travel on Sunday could be better so avoided. After prolonged argument the recommendation of the Council was adopted, and the meeting of 1896 will open at Buffalo at 10 A. M. on Monday, August 24th. It is hoped by this arrangement to avoid the considerable exodus of members which takes place under the present custom on Friday night. The subject is complicated by the Affiliated Societies, which now meet for the most part on Monday prior to the opening of the Association, and some of whose members desire to get away before it closes.

The relation of the Affiliated Societies has occasioned an increasing amount of discussion, some holding that they are very helpful to the Association, while others see in them a cause of diminishing interest in the Association. A committee was this year appointed to consider broadly the policy of the Association and its relation to the Affiliated Societies, and to suggest methods of improving the present state of affairs.

The close of the last session of the Association was marked by the presentation of a resolution of thanks, which was seconded with appropriate remarks by a number of members of the Association, and ably replied to by ex-Lt. Gov. W. H. Haile. Thus ended a meeting which, if small in number, was nevertheless one of the most successful and helpful meetings which the Association has known.

JAS. LEWIS HOWE,
General Secretary.

THE RELATION OF ENGINEERING TO
ECONOMICS.*

In the first page of Mr. J. R. McCullough's 'Introductory Discourse' (published

* Vice-Presidential Address delivered before Section D, Mechanical Science and Engineering, of the American Association for the Advancement of Science, at Springfield, Mass., Aug. 29, 1895.

in 1828) to his edition of Dr. Adam Smith's work, 'An Inquiry into the Nature and Causes of the Wealth of Nations,' he gives one of the best definitions we have of the science of political economy. "Its object," he says, "is to point out the means by which the industry of man may be rendered most productive of those necessaries, comforts and enjoyments which constitute wealth; to ascertain the proportion in which this wealth is divided among the different classes of the community, and the mode in which it may be most advantageously consumed."

The definition of engineering given by Tredgold, and incorporated into the charter of the British Institution of Civil Engineers, is 'The art of directing the great sources of power in nature for the use and convenience of man.' Rankine says: "The engineer is he who by art and science makes the mechanical properties of matter serve the ends of man."

Mr. George S. Morison, President of the American Society of Civil Engineers, in his address at the convention of the Society in June this year, says:

"Every engineering work is built for a special ulterior end; it is a tool to accomplish some specific purpose. Engine is but another name for tool. The highest development of a tool is an engine which manufactures power."

Comparing the above definitions of political economy and of engineering, we find they are closely related. Political economy, according to McCullough, points out the means by which the industry of man may be rendered most productive of wealth. If we asked the merest tyro in knowledge of human industry by what means industry might be rendered most productive, he would naturally answer, 'by the use of tools.' The engineer is the tool builder. His best work is the building of an engine which manufactures power, makes industry

most productive and manufactures commodities which are the elements of wealth. Political economy, which points out the means by which industry may be made most productive, should, therefore, point out tools and engines. But, strange to say, the writers on political economy have almost entirely neglected to point out those means. Their 'dismal science,' as it is called, generally points out everything but tools and engines. It treats of buying and selling, of supply and demand, of rents, interest and wages, of tariffs, of money and currency, of land values, taxes, and what not; but, with rare exceptions, does not mention engineering, which is the most potent force in the economics of the nineteenth century.

Adam Smith, the first great English writer on political economy, writing in 1776, when he was, of course, not to be blamed for knowing nothing of the engineering of this century, said: "The greatest improvement in the productive power of labor, and the greater part of the skill, dexterity and judgment with which it is anywhere directed or applied, seem to have been the effects of the division of labor." He gives a famous instance of the division of labor in the manufacture of pins. One man, he said, might with difficulty make one pin a day, and certainly could not make twenty. But as the manufacture was carried on in his day, by division of labor one man draws out the wire, another straightens it, a third cuts it, a fourth points it, a fifth grinds it at the top for receiving the head, and so on, dividing the labor up among ten men, and eighteen different operations. Those ten men thus made between them 48,000 pins per day. Most writers on political economy have followed Adam Smith, and given division of labor the credit for making the greatest improvement in production, and neglected the still more important improvement, the introduction of machinery, by which the labor of ten men was all done by

a machine with one man tending it. But I find that Robert Ellis Thompson in his work on political economy (1875) mentions the case of the pin industry in its modern phase. He says: "An inventive mechanic has put together a machine that only needs to be fed with wire, well oiled and supplied with steam power, to turn out complete pins, sort them, and even thrust them into the papers in the right numbers and in straight rows."

The example of the pin industry may be taken as representative of what has taken place in every branch of productive industry. By the use of the steam engine and of other machinery the productive power of human labor has been increased a thousand fold, and engineering thus becomes the most important force which has caused an industrial and economic revolution throughout the civilized world, and the one subject of all others which should be discussed by a political economist.

Political economy being broadly the science of wealth, and since wealth is property, and property, according to some writers of the socialist school, is robbery, it may be well to get our bearings here, and see whether wealth is a thing to be desired or not. I quote here the words of Mr. McCullough in his 'Introductory Discourse,' above mentioned, and without further argument may say, that I agree with him entirely: "The acquisition of wealth is not desirable merely as the means of procuring immediate and direct gratification, but as being indispensably necessary to the advancement of society in civilization and refinement. Without the tranquillity and leisure afforded by the possession of accumulated wealth, those speculative and elegant studies which expand and enlarge our views, purify our taste, and lift us higher in the scale of beings, can never be successfully prosecuted. It is certain, indeed, that the comparative barbarism and re-

finement of nations depend more upon the comparative amount of their wealth than on any other circumstance. It is impossible to name a single nation which has made any distinguished figure either in philosophy or the fine arts without having been at the same time celebrated for its wealth."

Having thus settled the question of the desirability of wealth, let us consider what is the engineer's share in its production. The great forces of nature which the engineer utilizes for the production of wealth are the forces of wind and of running water, and the stored energy of fuel in the forests, peat bogs, coal mines and gas and oil wells. By far the greatest of these forms of stored energy is that of coal. Let us compare for a moment the work that can be done by a ton of coal with the muscular power of men. One man digging coal from the side of a hill can easily dig two tons, say 4,000 lbs. of coal, in a day. Another man running a boiler and engine can burn these same two tons under a boiler, and if the engine is a moderately good non-condensing engine using 3 lbs. of coal per indicated horsepower per hour, it will develop from the two tons of coal 133 horse-power for 10 hours, equivalent to the physical labor that could be done by 1,300 men. Thus a man's labor by means of coal and a steam engine can be multiplied 650 times. But if we use a large high-grade triple-expansion, condensing engine, it will require only half as much coal per horse-power, and then if we set the engine to work to mine the coal itself, through the agency of mining machinery, and to feed its own coal to the boiler by means of automatic stokers, we see that the effectiveness of man's labor can be still more vastly increased.

Let us consider some of the results which the engineer has been able to accomplish by the utilization of coal.

In my study of the subject of this address, while I have failed to find it properly treated

in any of the standard works on political economy to which I have had access, I have found it discussed in a more or less fragmentary manner in writings and addresses of numerous engineers, statisticians and other specialists, and since it is more convenient to quote largely from their writings than to write anything original, I will now trouble you with some quotations.

I first quote from a recent lecture by Mr. Edward Orton, State Geologist of Ohio, before the Ohio Mining Institute :

"All the great applications of the stored power of the world belong to the nineteenth century, and the most important of them belong to the last 50 years. What has been done within this century constitutes by far the most important chapter in the economic history of the race. Fossil power lies at the root and center of this unparalleled advance. In Great Britain alone coal does the work of more than 100,000,000 men. It adds to the wealth of these fortunate islands on this basis.

"The great powers, those that are making over the world, are steam and electricity. The steam engine lies at the bottom of by far the greatest industrial and economic revolution through which the race has ever passed, and steam is now being reinforced by the new motor, from which we justly expect so much.

"We note some further consequences of the discovery and use of fossil power on the large scale. We shall find the most striking characteristics of our day and age, so far as the material side of life is concerned, centering around this one element. What are these characteristics of the nineteenth century? There are no more distinctive features of our time than the two following: viz., the remarkable growth of cities throughout the civilized world and the unparalleled increase of the wealth of men. Both take their rise in coal; both are conditioned by its use in all their phases

and stages. All modern manufactures are absolutely dependent on the stored force of coal. Machinery driven by this power is everywhere replacing the skilled labor of the olden time. Cities grow largely by massing the ruder labor that our modern factories can utilize.

"With this growth of cities in the modern world, a group of problems arises, all of which are new and of which we are obliged to work out the solutions. No other problems of equal gravity and urgency confront the statesman, philosopher or philanthropist of our day. All of them have their root in coal."

Mr. John Birkinbine, Past President of the American Institute of Mining Engineers, estimates that if only 1% of the consumption of fuel of all kinds in the United States, including coal, wood, oil and gas, were saved, it would be equal to 2,300,000 tons of coal per year. It is the work of the engineer to devise ways and means to accomplish this saving and more.

Mr. Chas. H. Loring, Past President of the American Society of Mechanical Engineers, in his Presidential address in 1892 thus spoke of the influence of the steam engine upon civilization:

"The civilizations of antiquity were limited to a few cities, and were based upon a slave labor, the slaves being drained from other places, which were thus doomed to deepening barbarism.

"The disgrace of the ancient civilization was its utter want of humanity. Justice, benevolence and mercy held but little sway; force, fraud and cruelty supplanted them. Nor could anything better be expected of an organization based upon the worst system of slavery that ever shocked the sensibilities of man. As long as human slavery was the origin and support of civilization, the latter had to be brutal, for the stream could not rise higher than its source. Such a civilization, after a rapid culmination,

had to decay, and history, though vague, shows its lapse into a barbarism as dark as that from which it had emerged.

"Modern civilization also has at its base a toiling slave, but one differing widely from his predecessor of the ancients. He is without nerves and he does not know fatigue. There is no intermission in his work, and he performs in a small compass more than the labor of nations of human slaves. He is not only vastly stronger, but vastly cheaper than they. He works interminably, and he works at everything; from the finest to the coarsest he is equally applicable. He produces all things in such abundance that man, relieved from the greater part of his servile toil, realizes for the first time his title of Lord of Creation. The products of all the great arts of our civilization, the use of cheap and rapid transportation on land and water, and of printing, density of population everywhere, the instruments of peace and war, the acquisition of knowledge of all kinds, are made the possibility and the possession of all by the labor of this obedient slave, which we call Steam Engine.

"We who were born under this benign influence but vaguely appreciate its value, and rarely recognize our obligations to it; existing civilizations would be impossible without it, and if human ingenuity finds no substitute for it they will perish with it.

"The steam engine is a machine which has been the prolific parent of other machines. It has caused the invention and construction of the immense plant of ingenious power tools employed in its own fabrication; it has caused the improvement of metallurgy as a science and of the various methods of metal manufacture as an art; it may be said to have created whole branches of important manufacture, and to have been the occasion of the invention of the immense mass of highly-diversified machinery, by means of which these manufactures are

practiced; and, last and greatest, it has stimulated and directed the human intellect as nothing else ever has, and has done more to advance human nature to a higher plane than all which statesmen, generals, monarchs, philosophers, priests and artists have ever accomplished in the vast interval which separates original man from the man of to-day. It has raised man from an animal to something approaching what a great intelligence should be, by simply placing in his hands a limitless physical power capable of application in every conceivable direction and to every conceivable purpose."

The value of the invention of Bessemer steel to the human race is discussed as follows in an address by Mr. Abram S. Hewitt in 1890 ('Trans. Amer. Inst. Mining Engineers,' Vol. XIX., p. 518):

"The Bessemer invention takes its rank with the great events which have changed the face of society since the Middle Ages. The invention of printing, the construction of the magnetic compass, the discovery of America and the introduction of the steam engine are the only capital events in modern history which belong to the same category as the Bessemer process. They are all examples of the law of progress, which evolves moral and social results from material development. The face of society has been transformed by these discoveries and inventions.

"Steel is now produced at a cost less than that of common iron. This has led to an enormous extension in its use and to a great reduction in the cost of the machinery which carries on the operations of society. The effect has been most marked in three particulars: First, the cost of constructing railways has been so greatly lessened as to permit of their extension into sparsely-inhabited regions, and the consequent occupation of distant territory otherwise beyond the reach of settlement; second, the cost of transportation has been reduced to so low

a point as to bring into the markets of the world crude products which formerly would not bear removal, and were thus excluded from the exchanges of commerce; third, the practical result of these two causes has been to reduce the value of food products throughout the civilized world, and, inasmuch as cheap food is the basis of all industrial development and the necessary condition for the amelioration of humanity, the present generation has witnessed a general rise in the wages of labor, accompanied by a fall in price of the food which it consumes. * * * * These are material results, but they are accompanied with the slow but sure elevation of the great mass of society to a higher plane of intelligence and aspiration."

The increase of working power of the United States is thus shown by Mr. M. G. Mulhall, the great statistician, in the *North American Review* for June, 1895. The working power of an able-bodied male adult is 300 foot-tons daily; that of a horse, 3,000, and of steam horse-power, 4,000. On this basis the working power of the United States was at various dates approximately as follows in millions of foot-tons daily:

| Year. | Hand. | Horse. | Steam. | Total. | inh. ^b nt. |
|--------------------|-------|--------|--------|---------|-----------------------|
| 1820..... | 753 | 3,300 | 240 | 4,293 | 446 |
| 1840..... | 1,406 | 12,900 | 3,040 | 17,346 | 1,020 |
| 1860..... | 2,805 | 22,500 | 14,000 | 39,005 | 1,240 |
| 1880..... | 4,450 | 36,600 | 36,340 | 77,390 | 1,545 |
| 1895..... | 6,400 | 55,200 | 67,700 | 129,400 | 1,940 |
| Gt. Britain 1895. | 3,210 | 6,100 | 46,800 | 56,110 | 1,470 |
| Germany, 1895. | 4,280 | 11,500 | 29,800 | 45,580 | 902 |
| France, 1895..... | 3,380 | 9,600 | 21,600 | 34,580 | 910 |
| Austria, 1895..... | 3,410 | 9,500 | 9,200 | 22,510 | 560 |

Notice from this table how vastly the power of man is increased by the use of the steam engine, and in United States how great was the increase in the last 15 years.

The wealth of the American people, says Mr. Mulhall, surpasses that of any other nation past or present. "The physical and mechanical power which has enabled a community of woodcutters and farmers to be-

come, in less than 100 years, the greatest nation in the world, is the aggregate of the strong arms of men and women, aided by horse-power, machinery and steam power applied to the useful arts and services of every-day life. The accumulation of wealth in the United States averages \$7,000,000 daily."

The increase of wealth in the United States is shown as follows, according to Mulhall:

| Year. | Total wealth, millions of dollars. | Wealth per capita. |
|-----------|---------------------------------------|-----------------------|
| 1820..... | 1,960 | \$205 |
| 1840..... | 3,910 | 230 |
| 1860..... | 16,160 | 514 |
| 1880..... | 43,642 | 870 |
| 1890..... | 63,037 | 1,039 |

Wealth per capita in different countries in 1890;

| | |
|--------------------|---------|
| Great Britain..... | \$1,260 |
| France..... | 1,130 |
| Holland..... | 1,089 |
| United States..... | 1,039 |
| Belgium..... | 840 |
| Germany..... | 730 |
| Sweden..... | 630 |
| Italy..... | 480 |
| Austria..... | 475 |

Average yearly wages per operative in the United States:

| | |
|-----------|-------|
| 1860..... | \$289 |
| 1870..... | 302 |
| 1880..... | 347 |
| 1890..... | 485 |

Rural or agricultural wealth in the United States has quadrupled in 40 years, while urban wealth has multiplied sixteen-fold.

| Year. | Millions of dollars. | | | Per cent of total | |
|-----------|----------------------|--------|--------|-------------------|--------|
| | Urban. | Rural. | Total. | Urban. | Rural. |
| 1850..... | 3,169 | 3,965 | 7,136 | 44.4 | 55.6 |
| 1860..... | 8,180 | 7,980 | 16,160 | 50.6 | 49.4 |
| 1870..... | 15,135 | 8,900 | 24,035 | 63.0 | 37.0 |
| 1880..... | 31,583 | 12,104 | 43,642 | 72.2 | 27.8 |
| 1890..... | 49,065 | 15,982 | 65,037 | 75.4 | 24.6 |

During the last 20 years the increment of rural wealth has been almost uniform at \$47 per head per annum of the number of rural workers. In urban workers the accumulation averaged \$83 per annum, which suffices to explain the influx of population into towns and cities.

The increased productiveness of the farmer, due to his use of machinery, is shown as follows:

"An ordinary farm hand in the United States raises as much grain as three in England, four in France, five in Germany and six in Austria, which shows what an enormous waste of labor occurs in Europe because farmers are not possessed of the same mechanical appliances as in the United States.

"In the United States one man can feed 250, whereas in Europe one man feeds only 30 persons. Nor can we hope for a better state of things in Europe soon. So dense is the ignorance of most men, even among the educated classes, that they are convinced that all labor-saving appliances are an evil, and that the more persons there are employed to do any given work the better."

During a visit to Germany three months ago I learned of an instance of this ignorance among the laboring classes. My traveling companion saw three men cutting grass on a lawn with ordinary scythes and sickles. "Why don't you use a lawn mower?" said he, "then one man could do as much as three are now doing." "Don't talk to us about lawn mowers," said one of the men, "it is all we can do now to find work enough to earn our bread. If we had a lawn mower two of us would starve." They did not think that if their employer saved the wages of two men, the money would burn a hole in his pocket until he either employed it for some useful purpose, by giving employment to either the same two men or two others, or loaned it to some one who would employ it.

In the United States, however, the old-time opposition to the introduction of labor saving machinery as a harm to the laboring man, throwing him out of employment, has now almost died out among reasoning men, and it is generally acknowledged by men

who have studied the subject that the steam engine and labor-saving machinery in general are the chief agents of the civilization of the latter half of the nineteenth century, and that they have increased the productiveness of man's labor, increased his wages, shortened his hours of labor, cheapened his food and clothing and given the average man comforts and luxuries which a century ago not even kings would have commanded.

Mulhall's 'Dictionary of Statistics' (1892) gives the following facts concerning the agriculture of the world. "Capital and product have more than doubled since 1840, but the number of hands has not risen 50 per cent.

Agricultural Capital of the World Millions of Dollars.

| | Land. | Cattle. | Sundries. | Total. |
|-----------|--------|---------|-----------|---------|
| 1840..... | 35,475 | 4,970 | 4,735 | 45,180 |
| 1860..... | 59,310 | 7,810 | 7,495 | 74,615 |
| 1887..... | 88,880 | 13,505 | 12,645 | 115,030 |

Agricultural Capital in the United States. Millions of Dollars.

| | Land. | Cattle. | Sundries. | Total. |
|-----------|--------|---------|-----------|--------|
| 1840..... | 2,000 | 480 | 500 | 2,980 |
| 1860..... | 6,910 | 1,190 | 1,185 | 9,225 |
| 1887..... | 12,800 | 2,505 | 3,175 | 18,480 |

"In the United States 9,000,000 hands raise nearly half as much grain as 60,000,000 hands in Europe. Thus it appears that for want of implements and of proper machinery there is a waste of labor equal to 48,000,000 of peasants."

The census returns of the manufacturers of the United States, 1880 and 1890, show the following:

| | 1880. | 1890. | Increase per cent. |
|---|-----------------|-----------------|--------------------|
| No. of establishments re- porting..... | 253,502 | 322,624 | 27.27 |
| Capital..... | \$2,780,766,805 | \$6,138,716,604 | 120.76 |
| Av. No. of employees..... | 2,700,732 | 4,476,094 | 65.74 |
| Total wages..... | \$930,462,252 | \$2,171,356,919 | 130.13 |
| Cost of materials used..... | 3,395,925,123 | 5,018,277,603 | 47.77 |
| Value of products..... | 5,349,191,458 | 9,654,191,458 | 69.27 |

Vast economic changes throughout the world have recently taken place as the result of the development of engineering. Mr. Edgerton R. Williams in his article on 'Thirty Years in the Grain Trade' (*North American Review*, July, 1895), says:

"In 1869 97% of England's population, say, 18½ out of 19 millions, were fed on English-grown wheat. In 1890, with a population of 25 millions, only 5 millions were supplied with English wheat, a falling-off of 77%. The decrease in wheat average in 40 years, from 1846 to 1886, was nearly 66%."

The tendency of population from the country to the cities is a consequence of the increased production of manufactures and of the decrease in the percentage of the total population required to produce the food of the world. This tendency in the United States is shown in the following census figures:

| | Urban population, per cent. of total. | | | | |
|--------------------|---------------------------------------|-------|-------|-------|-------|
| United States..... | 1850 | 1860 | 1870 | 1880 | 1890 |
| Per cent..... | 12.49 | 16.13 | 20.93 | 22.57 | 29.12 |

In the northern central division of the United States, in the past ten years, the urban element has nearly doubled, while the total population has increased only 25.78%. The increase in urban population is confined mainly to a few large cities.

The completion of the Trans-Siberian Railroad, and the extension of railroads in India and in the Argentine Republic will probably before long make Europe independent of the grain crop of America. Mr. Worthington C. Ford, Chief of the United States Bureau of Statistics, in the *North American Review* for August, says: "It is now the Argentine Republic which appears to have an almost unlimited power to grow and export wheat in defiance of any competition." The perfection of refrigerating machines—an engineering triumph—makes it now possible for Europe to receive its supply of meat from Australia and from the Argentine Republic, as well as from the United States. The introduction of modern cotton machinery into Japan and into India threatens the cotton trade of England with exclusion from the markets of Asia, one of England's greatest present resources. In Australia, according to Mr. Ford, the

ranchmen are successfully overcoming one of the most serious obstacles to the extension of sheep raising, by sinking artesian wells and making pools or dams to retain the water for their stock—another example of the application of engineering in using nature's stored forces to overcome the resistance of nature. There thus appears to be no limit to the economic changes throughout the world which may yet be made by the use of engineering appliances.

Marked economic effects have attended the building, or failing to build, important highways in the United States of whatever kind where opportunity and need existed. The early topographical engineers of the country, including especially George Washington, who was an engineer by profession, foresaw that at whatever point on the Atlantic coast an outlet should be made for the products of the Ohio and Mississippi valleys, a great, probably the greatest, seaport would arise. Virginia was at this time far in advance of the other States, and especially of New York. * * * Washington urged the Legislature of Virginia to build a canal connecting the Ohio River and the James or Potomac, so as to place the outlet at Norfolk. His advice was not heeded. Subsequently New York, under the leadership of De Witt Clinton, constructed the Erie Canal, connecting Lake Erie, at Buffalo, with the Hudson, at Albany, then a stupendous feat of State enterprise in finance and civil engineering. Until that canal was built New York city had little more than the trade of the Hudson River valley. The building of the canal made New York the Empire State, and the city the commercial metropolis of the Union—Denslow, p. 150.

Who can estimate the economic value to the United States of that great feat of engineering, the building of the first railroad across the continent? What an increase of the wealth of nations has flowed from the opening of the Suez Canal, and what another

increase will follow the completion of the Nicaragua Canal!

Improvements in engineering methods often cause the destruction of vast amounts of fixed capital by the substitution of new appliances for the old. The British government expended in 1864-'70 £20,000,000 on a class of armored gunboats, which, before any use was made of them, were condemned as worthless, owing to the improvements in the construction of guns. It expended large sums on iron guns, which became useless by the substitution of steel guns, etc.

A telegraph company expended large sums of money in constructing a line through Siberia and Alaska, whereby to get telegraphic communication between New York and London via San Francisco and Behring Straits, which was made totally worthless by the laying of the first Atlantic Cable (Denslow, p. 81). Numerous canals and canal boats have been thrown out of use and allowed to fall into decay on account of the competition of railroads.

Between 1872 and 1880 a revolution took place in the construction and in the method of driving blast furnaces for making iron, so that of 700 blast furnaces running or in condition to run in 1872, probably not 50 are now on the active list, and although the production of iron has more than quadrupled since that date, only 480 furnaces are now on the list of existing furnaces, and more than half of these are out of blast. The destruction of capital involved in the abandonment of old furnaces is probably over \$100,000,000. A similar destruction of fixed capital has followed the substitution of Bessemer steel for puddled iron, and the introduction of improved forms of rolling mills. A great decrease in the value of the iron mines of New Jersey, New York and Pennsylvania has followed the opening of better mines in Lake Superior.

One of the great achievements of engi-

neering is the substitution of the factory system of labor for the old domestic system. The beginning of the factory system was in the decade of 1760-1770, when the spinning jenny, the spinning frame and the spinning mule were introduced into the textile industry, but it did not begin its full career of development until after Watt had perfected his steam engine about thirty years later. Has the factory system been a benefit to civilization? There is no better authority on this question than Mr. Carroll D. Wright, formerly United States Commissioner of Labor, and now Commissioner of the Census of 1890. He says: (Johnson's Cyclopædia, Vol. III., p. 265): "The factory system is in every respect vastly superior to the domestic system as an element of civilization, although this is contrary to popular impression and largely against popular sentiment. * * * Under the domestic system the home of the worker was the workshop also, and the wheels or looms disputed with the inmates for the room and the conveniences for house work. Small, close crowded, with bad air and bad surroundings, the hut of the domestic worker was occupied by a class which had not found, and cannot find, its like under the factory system, for, as a rule, the operative of to-day occupies a home even in the factory tenement or boarding house superior in every sense to the home of the domestic worker.

"Under the domestic system of industry grew up that great pauper class in Great Britain which was a disgrace to civilization. It continued to grow, until one-fourth of the annual budget was for the support of paupers. * * * The domestic labor's home was far from having the character poetry has given it. Huddled together in what poetry calls a cottage and history a hut, the weaver's family lived and worked without comfort, conveniences, good food, good air, and without much intelligence. Drunken-

ness and theft of materials made many a house the scene of crime and want and disorder. Superstition ruled, and envy swayed the workers. Ignorance under the old system added to the squalor of the homes of the workers under it, even making the hut an actual den, shared in too many instances by the swine of the family. The home of the agricultural laborer was not much better; in fact, in Great Britain and France he has to a great degree continued in his ignorance and in his degraded condition.

"One of the positive results of the factory system has been to enable men to secure a livelihood in fewer hours than of old. This means intellectual advancement, for, as the time required to earn a living grows shorter, civilization progresses. * * * The fact that the lowest grade of operative can now be employed in factories does not signify more ignorance, but a raising of the lowest to higher employments. This process is constantly narrowing the limits of the class which occupies the lowest step in the progress of society. This mission alone stamps the system as an active element in the moral elevation of the race. The factory system does not tend to intellectual degeneracy."

The arguments thus far adduced have all been one-sided in showing that an increase in civilization and in refinement follows an increase in wealth. There is another side to the question. A portion of the laboring masses are dissatisfied. This side is ably treated in this month's issue of the *North American Review*, by Rev. J. S. Zahm, C. S. C., entitled 'Leo XIII. and the Social Question.' I quote as follows:

"In lieu of the old organic regime the French Revolution substituted the reign of individualism. Unlimited competition, freedom of labor, the preponderance of capital and the general introduction of machinery ushered into existence the fourth estate proletarians, or wage-earners—and with it the

social question. The organism became a mechanism, and from its excesses proceeded the evils from which we now suffer. As matters at present stand, we have two inimical forces, standing face to face; on one side, the modern state, with its army and its police; on the other, socialism and organized labor with its battalions and its long pent-up grievances.

"Never before was humanity confronted with such a danger. Three centuries of renaissance of pagan law and a century of *laissez-faire* and *laissez-passer* have atomized society and divided the human family into two opposing camps—on one side the tyranny of the law and of the employer; on the other, renewed servitude and virtual rebellion—everywhere hatred, lack of equilibrium, egotism and overt struggle.

"Formerly after the struggle between employer and employee was over, rest and peace were to be found in the workshop or in the home, whereas to-day the struggle has reached our very hearthstones. It persists in a dull and sullen manner, when it does not break forth openly, and it is ever compassing the ruin of society because it is incessantly destroying all chance of domestic happiness. Never before, indeed, has the social question knocked in so threatening a manner at the doors of the civil order."

Mr. Zahm charges machinery, which is engineering, with being one of the chief causes of social troubles. He says further:

"It may truly be said that the social question arises from a five-fold revolution: the revolution in machinery; the revolution in political economy; the revolution in religion; the revolution in the state, and the revolution brought about by the general movement of humanity.

"Machinery, or rather the abuse of machinery, was the first to effect a transformation in the economic order. It is not without reason that Lasalle styles it 'the revolution incarnate'—*Die verkörperte Revo-*

lution. Machinery has revolutionized the mode of production, the manner of labor, and the distribution of revenue and of property. It has destroyed the workshop and introduced the factory in its stead. It has sterilized manual labor, and, by its immense productivity, has internationalized prices and markets. While, on the one hand, it has created the despotism of capital, it has, on the other, called into existence the unorganized army of the proletariat. It has ground humanity into a powder, without cohesion and without unity, and has placed the world of labor at the mercy of a few soulless plutocrats. This new order of things means the reign of the few; it implies the permanence of expropriation and the resurrection of ancient Rome, where millions of slaves were trampled under foot by an insolent oligarchy of wealth. And finally, by its fatal centralization machinery has engendered a double International—the International of capital and the International of socialism. Never has a more complicated situation, or one more pregnant with peril, weighed upon men. What were the invasions of the barbarians from the north of Europe, or the upheavals of the fifteenth and eighteenth centuries, in comparison with the threatened explosion of this vast world already stirred to its profoundest depths and in a state of violent ebullition?"

The remedy for this terrible state of affairs, according to Mr. Zahm, is to be found in following the advice given in the recent encyclical letter of the Pope. I quote.

"In the introduction to his epoch-making document, Leo XIII. directs attention to some of the evidences of the dominant evil, extreme riches, extreme misery, and the indescribable desolation which has entered the world of the proletariat in consequence of the atomization of society under the leveling reign of capital.

"As in the politico-religious order, Leo

XIII. has, through his encyclical '*Immortale Dei*,' preached the code of reconciliation, so has he, in the economic order, promulgated the character of social harmony. For the first time economic science has pity on the wage-earner, and discusses the new issues raised without rancor or recrimination. At the same time it exhibits a respect for the rights of all while insisting on the duties of all, which will forever render the encyclical, '*Rerum Novarum*,' not only the most glorious monument of the present pontificate, but also the most beneficent contribution yet made to the new order of things."

We must give all honor to Pope Leo XIII. for his earnest efforts to bring about social harmony, but Mr. Zahm is surely not right in saying that this is the first time that economic science has pity for the wage-earner. Many writers in all schools—Henry George, for example—have been animated by sincere sympathy for the wage-earner, and have earnestly discussed means of ameliorating his condition. I hope to show in my conclusion that the whole tendency of economic evolution is toward bettering the condition of the wage-earner.

Mr. Hewitt in his Presidential address before the American Institute of Mining Engineers in 1890, entitled '*Iron and Labor*,' '*Trans. A. I. M. E.*' Vol. XIX., pp. 496, 497, speaks of 'the new era,' when every intelligent workman will insist on being an owner, and every well-managed corporation will see that its workmen are directly interested in the results of the business. He says: "The time is approaching when capitalists and laborers will more and more be joint owners in the instruments of production. While the wages system will necessarily survive, the workmen will, to a large extent, become their own employers, and finally may hire capital as capital now hires labor. The facilities offered for the division of prop-

erty, through the distribution of corporate shares, will lessen strife, develop skill, reduce cost, increase production and promote the equitable distribution of wealth, which, it must never be forgotten, is the chief end of the social organization."

The equitable distribution of wealth which Mr. Hewitt speaks of is the aim of all honest political economists of all schools. They only differ as to the means through which it is to be brought about, and they differ vastly in their apprehension of what is the existing state of things. The chief difficulty of the socialist writers and such men as Henry George and Mr. Zahm is that they do not see clearly the existing facts. Seeing the vast wealth of a few individuals, they preach the dictum the 'rich are growing richer and the poor are growing poorer,' the last half of which is a stupendous economic falsehood, equalled only by the dictum of the anarchists that 'property is robbery.' Innumerable facts can be adduced to show that the statement that the poor are growing poorer is a falsehood. Statistics prove beyond all question that in all the civilized world the wages of labor have tended, ever since the extensive use of the steam engine, say, since 1850, to increase, and the cost of living to decrease. Statistics of savings banks, of building associations, of life insurance companies, of fraternal assessment life insurance associations, of the ownership of small houses and small farms, of the reduction of mortgages on farms, all show that not only is there a vast increase in the wealth of the Nation as a whole, but that this wealth is being more widely distributed than ever before. A magazine article recently said that more than one-half of the entire population of New England, including men, women and children, are depositors in the savings banks, the average amount to the credit of a depositor being \$363. It says of the depositors: "If it were possible to prove what is

apparent to the eye of any one who watches the customers of these banks, it would be found that very much the largest part of them are the women and children. The aggregate deposits in the savings banks in New England is \$774,000,000. In New York State alone it is \$644,000,000." In the little town in which I live, Passaic, N. J., containing 18,000 inhabitants, a considerable part of the population are Poles, Bohemians, Hungarians and other natives of southern Europe. They are recent immigrants, working in mills; yet one of the two savings banks in the city has 2,500 depositors, the deposits amounting to nearly \$400,000; and in addition these same foreigners last year sent to Europe, in the shape of drafts issued by this same bank, not less than \$50,000.

Place the statements just made concerning savings banks against those made by Mr. Zahm—viz., that the human family is divided into two opposing camps; that we have two inimical forces standing face to face: on one side the modern State with its army and its police; on the other socialism and organized labor. How can we reconcile these two apparently conflicting views of the existing status? Why, very easily. Mr. Zahm's two opposing camps exist: on one side the socialists, on the other side the police; but his eyes were blinded when he said that the whole human family is divided into two opposing camps. He failed to see the vast majority of the people who belong to neither one camp nor the other, who are the savings bank depositors, the owners of small homes, albeit with small mortgages on them, who are members of building associations and fraternal life insurance societies. The grandest fact in the economic history of this age is the great increase in the number of the people in comfortable circumstances who once were numbered among the poor. The increase in the middle class goes along with a great decrease in the

number of the very poor. The poor are growing poorer, say the agitators. Whom do you mean by the poor? Is it a family that has only \$100 in the savings banks? Next year it will have \$200 and five years thence \$1,000.

Do you mean, then, we ask the agitator, the man who has not a dollar in any bank, who has not enough ahead to keep him from starvation a week? If he is the man whom you call poor, and whom you have been saying for the last 20 years that he is growing poorer, how much poorer is he going to get? How many such men are there in the United States? Let them stand up and be counted.

We have seen that engineering is the chief factor in the production of wealth; that wealth has enormously increased in the past few years, and that it is being well distributed, although perhaps not as well as it ought to be, among the common people. What of the future? Engineering has caused men to leave the farm and seek the cities, because in the cities they can grow rich faster. Engineering, again, through rapid transit, electric cars and the like, is making it possible for these men who work in the city to sleep in the suburbs, and bring up their families in a place which has all the advantages of city and country combined. One of the triumphs of the iron-making engineer has been the construction of a hollow steel tube of great lightness and strength. The mechanical engineer has found out how to make ball bearings, and lo! we have the bicycle of 1895, 400,000 of them to be made in this year. Who can estimate the value to the people of this new industry, building up an athletic and healthy race of men and women, and causing good roads to be built from one end of the country to the other, another work of engineering by which the farmer may move his crops more cheaply and the cost of food be correspondingly decreased. What next? As

Mr. Hewitt has foreseen, the wage-earner will become a stockholder in the corporations for which he works, and labor will hire capital, instead of capital hiring labor. Then what Mr. Zahm calls the fourth estate, the proletariat, will cease to exist. It will be merged into the third estate, the common people, who are at the same time wage-earners and capitalists. The proletariat, or fourth estate, as a separate element in society, antagonistic to the third estate, is already a vanishing quantity. We who are old enough remember the alarm created throughout the world in the years 1867, 1868 and 1869 when the dreaded 'International' held its congresses in Europe. Who now dreads the International. True, it may be strong enough some day in some one or more places to repeat the terror of the Paris Commune in 1871, but the uprising will end as the uprising of the Commune did, and it will not take two months to end it, as it then did.

"The Empire is peace," said Napoleon III. just before the Franco-Prussian War. He was mistaken. The war took place, causing vast loss and suffering, followed by the terrible agony of the Commune. But how nobly France recovered from the shock, how quickly she paid the indemnity to Germany out of the actual stored savings of her common people. No revolution in the social order took place, only a change in government, then everything went on as before. So it will be if the International should arise, as is predicted by the alarmists, and reproduce the horrors of the French Revolution. The world will live through it; the social order, as of old, will be restored, and the present relations of capital and labor will not be changed, except as by gradual and necessary evolution, due to engineering more largely than to any other one cause, capital and labor becoming merged by the laborers becoming capitalists. This will be the crowning triumph of engineering,

through which the increase of wealth is caused, which enables the laborer to become a capitalist. Then the political economists may meet together and discuss the improved social order, burn their old books, and erect a monument to the man who above all others contributed the means for obtaining the wealth of nations, James Watt, the engineer. WILLIAM KENT.

JOHN ADAM RYDER.*

IN 1875, exactly one score of years ago, John A. Ryder began his work at the Academy. Six of these years were spent in the service of the government. The remaining fourteen were in close communion with these halls. The museum and library were the scenes of his many labors.

At one time his friends feared that he was covering too large a field. Doubtless, the fear would have been sustained if Ryder had pursued his studies along conventional lines. But we must not judge him by such a standard. His mental attitude was well poised. The objects that 'swam into his ken' came from a wide space. So long as he was searching for the results of vital forces on the economy, it mattered little to him whether it was the teeth of mammals, the tails or scales of fishes, or the movements of protoplasm in a rhizopod that illustrated these actions.

While arranging the collections of the Academy as a Jessup Fund student he found material for his studies in teeth of quadrupeds; while on excursions in the city park, in the smaller articulated animals feeding on fungi or swimming in pools; while on the Fish Commission, in the oyster and its parasites and the movements of fishes; as professor of histology and em-

bryology at the University, in the preparation of specimens for courses of instruction.

What were the mental forces that operated in Ryder to make him what he was? This is of interest, for the result of comparative studies is to aid us in knowing ourselves. How strange is the phenomenon! First, a young student coming to the Academy so absolutely unknown that his first application to a position on the Jessup Fund was deferred. Second, his obtaining the position and setting to work on the collection, rearranging and cleansing specimens, refilling jars and cataloguing. Third, after a career of four years attracting the attention of Professor Baird and leaving the city to accept an appointment on the Fish Commission. Fourth, returning to Philadelphia in 1887 and again in frequenting the Academy, no longer working on its collections, but consulting its library and speaking at its meetings as a University professor. So we find Ryder at the beginning and at the end of his career part of the Academy. But where, in this chain of circumstances, do we find the factors which gave to Ryder those things which distinguish him? Almost precisely the same conditions (so far as the Academy and the University were concerned) were met with in Leidy. Yet how different were the two men! Indeed, so little did Leidy understand Ryder that he endeavored (with the most kindly motive) to dissuade him from a career of study. Leidy knew that men who are dependent on science for a livelihood secure fewer prizes in the struggle for maintenance than do those in any other learned calling. This statement is yet true, and it had special force twenty years ago.

Thus while the Academy gave Ryder incalculable aid (the soil, indeed, in which he grew), the influences which determined the character of his work were extraneous. These were in brief the influences of the

*An address on 'Dr. Ryder's relations to the Academy of Natural Sciences,' of Philadelphia, by Dr. Harrison Allen, given at the memorial meeting on April 10, 1895, and published by the committee in charge of publication.

theory of evolution as applied to living things, which brightening the horizon of science relieved it of all mists, such as the theories of Oken and its many variants, before men of Ryder's age looked toward the dawn for inspiration.

In America, to use Professor Packard's expression, a neo-Lamarckian phase of the theory of evolution arose. It held to an insistence of mechanical causes in modifying the shapes of organisms. Its advocates were Alpheus Hyatt and Edward D. Cope, men whom Darwin did not understand, but Ryder did; and, while he is in no respect a disciple of either of these distinguished men, his career was in a sense determined by them.

The forces which Ryder so eagerly studied were those which tended, as he believed they did, to modify endlessly the bodies in which they are exercised. The living body is compared by him to a machine in motion, which changes the shape of the machine itself by virtue of the motions; he believed that such changes are transmitted to offspring, and in this way organisms tend to endless variation. Nothing is fixed but the initial necessity to change.

Dr. Ryder might have done well had he confined himself more than he did to the study of species and genera. His papers in this line were excellent. He announced several forms of Thysanura, Myriapods, fresh water crustaceans, and a new fresh water polyp. He revised the account of the sturgeons of our eastern waters, and resuscitated Le Sueur's *Accipenser brevirostris*, an old specimen of which (probably part of the material on which the species was named) was found by Ryder in the Museum of the Academy.

In competent hands the elucidation of species is not, as it has opprobriously been said to be, a dullard's task of taking an inventory of nature, but the study of the ultimate forms which those organisms as-

sume which breed true. The shifting of color-schemes, the exhibition of the effects of retardation or precocity in the development of the individual, the effects of food and climate on size in whole or in parts, and of other causes by which minute differentiations are started and maintained, are of unending interest, and worthy of the best powers of the naturalist. If Ryder had been more closely identified than he was with the careers of the great academicians who had preceded him he would in no whit have detracted from the value of his philosophical labors. One cannot but regret, if for no other reason than for his health's sake, that he discontinued those fruitful excursions to our woods, ponds and rivers by which he contributed so notably to our micro-fauna.

With nameless regret, we note in what degree his exceptional powers were wasted. We see him in training as an oyster culturist, or busy with details of affairs on the Fish Commission. We see him giving his substance of energy to undergraduate instruction. Why do we insist that penknives are appropriate tools to fell oaks? that pedagogy is a suitable career for a man who has rare gifts for investigation? We may never see nor the world see the like of Ryder again. Why did we not get all that was possible from him while he was here, and leave the tasks of teaching undergraduates to those equally earnest with himself, to teachers as capable as himself, but who did not possess a tithe of his ability as an inquirer after truth? Teaching, it is true, gave him his maintenance, one which he preferred to any other. Alas! that there is no larger Jessup Fund for matured students as well as tyros! No complaint is here made that as compared with other students Ryder had not received due consideration. Nevertheless, bureau employment and teaching are not the best uses to which we can put exceptionally en-

dowed men. Ryder was patient and dignified. He was not a Pegasus chafing in his harness, but as one consecrated to the calling of his choice and on whose heart the lowliest duties on itself did lay. But we are the losers. We cannot but be saddened at the knowledge that he did not live to put in form and substance the results of his profound labors. His work is like an unfinished house webbed in scaffolding, with heaps of building material scattered about the ground. The spirits to which Ryder was kin (the Keats, the Mozarts), visit us at long intervals, and when they come we treat them as though they were ordinary mortals after all.

HARRISON ALLEN.

REPORTS OF INTERNATIONAL METEOROLOGICAL MEETINGS.

Two of these have lately been received; the first being the Report of the International Meteorological Congress, held at Chicago in August, 1893. This Congress was remarkable for the number of papers presented rather than for the number of persons who assembled to hear them read, and yet it seemed doubtful whether they could be published, as the Congress Auxiliary of the Columbian Exposition had no funds available. Fortunately, the U. S. Weather Bureau was able to accomplish this in its series of Bulletins, Bulletin 11, Part II., now before us, forming Part II. of the Report, which is devoted to history and bibliography, agricultural meteorology, atmospheric electricity and terrestrial magnetism. The first section is of special interest, as it contains a detailed account of the commencement and development of meteorology in the United States, with which the Army Medical Department, the Smithsonian Institution, the Hydrographic Office and the Signal Service were chiefly concerned. Two papers of much bibliographical interest, relating to English meteorological

literature from 1337 to 1699 and to meteorology and terrestrial magnetism in the fifteenth, sixteenth and seventeenth centuries, were contributed, respectively, by Mr. Symons, of London, and Dr. Hellmann, of Berlin, the two highest authorities on this subject. This Report is edited by Mr. O. L. Fassig, the able librarian of the Weather Bureau, who deserves great praise for effecting translations of the various foreign papers, with no pecuniary assistance, and otherwise performing a difficult task in so satisfactory a manner. Part I., which appeared more than a year ago, contained the papers on weather services and methods, rivers and floods and marine meteorology; while Part III. will comprise climatology, instruments and methods of observation and theoretical meteorology.

The second report to be mentioned is that of the International Meteorological Committee, chosen at the Munich Conference in 1891, which held its first meeting at Upsala in August, 1894. The proceedings are published in three languages, and the English edition, prepared by Mr. R. H. Scott, Secretary to the Committee, is issued as No. 115 of the official publications of the London Meteorological Office. The present members of the Committee and the countries which they represent are as follows: Messrs. von Bezold (Prussia), Billwiller (Switzerland), de Brito-Capello (Portugal), Davis (Argentine Republic), Eliot (India), Ellery (Victoria, Australia), Hann (Austria), Harrington (United States), Hepites (Roumania), Hildebrandsson (Sweden), Mascart (France), Mohn (Norway), Paulsen (Denmark), Scott (Great Britain), Snellen (Holland), Tacchini (Italy) and Wild (Russia). Among the most important resolutions was that the proposed International Meteorological Bureau was not realizable, but that the Committee appeared to be the proper body to establish and maintain relations between the

different institutions and to arrange for the carrying-out of investigations of general utility. It was decided that a conference, similar to that of Munich, should be held in Paris in September, 1896. The Cloud Committee, consisting of Messrs. Hann, Hildebrandsson, Mohn, Riggenbach, Rotch and Teisserenc de Bort reported upon the proposed cloud atlas, its cloud definitions and the instructions for observing them. It was recommended that measurements of the altitude of clouds (preferably by photographic methods) at a limited number of stations, and direct observation of the velocity of motion of clouds at a larger number of stations throughout the world, be commenced May 1, 1896, and continued one year.

A. LAWRENCE ROTCH.

THE AMERICAN CHEMICAL SOCIETY.

The *American Chemical Society* held its eleventh general meeting at Springfield, Mass., August 27th and 28th. The address of welcome was delivered by Mayor Charles L. Long, and the response to the same was made by the President of the Society, Professor Edgar F. Smith. No business was transacted, the entire time of the three sessions being wholly devoted to the reading of the following papers and to their discussion:

1. 'Determination of the Heating Effect of Coal,' W. A. Noyes, J. R. McTaggart and H. W. Craven.
2. 'Use of Aluminum for Condensers,' T. H. Norton.
3. 'A Case of Mistaken Identity' (relating to the tetrachloride of zirconium), F. P. Venable.
4. 'The Determination of Sulphur in Refined Copper,' George L. Heath.
5. 'The Possibility of the Occurrence of Hydrogen and Methane in the Atmosphere,' Francis C. Phillips.
6. 'The Evolution Method for the Determination of Sulphur in Iron,' Francis C. Phillips.
7. 'Metaphosphinic Acids and their Derivatives,' Henry N. Stokes.
8. 'The Analysis of Alloys Containing Tin, Lead and Antimony,' Launcelot Andrews.
9. 'Observations on Double Platinum Salts,' Charles N. Herty.

10. 'A New Electrical Process in Making White-lead,' R. P. Williams.
11. 'Estimation of the Extraction in Sugar Houses' (by title), M. Trubeck.
12. 'Tellurium, its Separation from Copper Residues with Notes on some New Reactions,' Cabell Whitehead.
13. 'Arsenic in Glycerol,' George E. Barton.
14. 'The Occurrence of Trimethylene Glycol as a Bi-Product in the Glycerine Manufacture,' Arthur A. Noyes.
15. 'The Electrolytic Reduction of Paranitro Compounds in Sulphuric Acid Solution,' Arthur A. Noyes.
16. 'Speed of Oxidation by Chloric Acid,' Robert B. Warder and Herman Schlundt.
17. 'Acidimetric Estimation of Vegetable Alkaloids,' Lyman F. Kebler.
18. 'A Study of Some of the Gas-producing Bacteria' (by title), A. A. Bennett.
19. 'Pierates' (by title), George B. Pfeiffer.
20. 'A New Burette Holder,' W. K. Robbins.
21. 'A New Form of Water Bath,' W. P. Mason.
22. 'The Reaction Between Concentrated Sulphuric Acid and Copper,' Charles Baskerville.

After all the papers had been read President Edward Morley, of the American Association, who was present, was called upon for remarks, and he summed up the results that have been secured by the various workers who have labored to determine with accuracy the atomic weight of oxygen, giving as the final probable average of the results 15.879. These remarks were of especial interest, as Prof. Morley himself has done more than any other investigator to determine the atomic weight of oxygen, spending years upon the subject and making a number of elaborate and careful determinations. President Smith, of the Society, then gave a warm tribute to the work done by Prof. Morley and congratulated the chemists of this country on having among their number one whose work ranks with the highest done by any investigator in the world.

The Society visited the works of the Holyoke Paper Company, of the Merrick Thread Company, the plant of the Farr Alpaca Company, the Hampton Paint and Chemical Company and the U. S. Arsenal.

The present membership of the Society is 950. Eight active sections now exist in various parts of the United States, with

the possibility of two more before the year closes.

The mid-winter meeting will be held at Cleveland, Ohio.

SCIENTIFIC NOTES AND NEWS.

RAILWAY SPEED IN GREAT BRITAIN.

MR. CHARLES ROUS-MARTIN, an English authority on railway working, published a paper in the *London Engineer* of August 9th, in which he discusses what has come to be called 'the railway race to Aberdeen,' between the East and the West Coast routes. It began July 1st by the reductions of the schedule time from 11 h. 35 m. and 11 h. 50 m. to 11 h. 40 m. by the West Coast line. East Coast, then, came to 11 h. 20 m.; then West Coast to 11 hours. Next East Coast made the 523 miles in 10 h. 45 m., July 22 and, the same day, West Coast 543 miles in 10 h. 45 m. The last figures to date were 10 h. 25 m. and 10 h. 20 m. The running speed ranges between 60 and 75 miles an hour, which figures have been repeatedly bettered, previously, for short distances, by local trains. The higher the speed, the steadier was the motion of the train. The present writer came up from Perth to Edinboro' on such trains and can report extraordinarily easy and smooth motion of engine and carriages at speeds estimated to be much above seventy miles for considerable distances. It is concluded that the American system of 'bogies' or 'trucks' is much better than the old English six-wheeled rigid type of carriage. The East Coast line employed single drivers 7 ft. 7 in. to 8 ft. 1 in. diameter and the West Coast two pairs coupled of 6 ft. 6 in. diameter. Speeds of 80 miles were sometimes touched; but rarely were the velocities considered extraordinary. The engines were in some cases simple, sometimes compound. All did magnificent work. The loads were 180 to 200 tons. R. H. T.

ROYAL SOCIETY OF NEW SOUTH WALES.

THE Society offers its Medal and £25 for the best communication (provided it be of sufficient merit) containing the results of original research or observation upon each of the following subjects:

Series XV.—To be sent in not later than 1st May, 1896. On the origin of Multiple Hydatids in man. On the Occurrence of Precious Stones in New South Wales with a description of the Deposits in which they are found. On the effect of the Australian Climate on the Physical Development of the Australian-born Population.

Series XVI.—To be sent in not later than 1st May, 1897. On the Embryology and Development of the Echidna or Platypus. The Chemical Composition of the Products from the so-called Kerosene Shale of New South Wales. On the Mode of Occurrence, Chemical Composition, and Origin of Artesian Water in New South Wales.

The competition is in no way confined to members of the Society, nor to residents in Australia, but is open to all without any restrictions whatever, excepting to members of Council for the time being. The communication to be successful must be either wholly or in part the result of origin observation or research on the part of the contributor. The Society is fully sensible that the money value of the Prize will not repay an investigator for the expenditure of his time and labor, but it is hoped that the honour will be regarded as a sufficient inducement and reward. The successful papers will be published in the Society's Annual Volume. Fifty reprint copies will be furnished to the author free of expense. Competitors are requested to write upon foolscap paper—on one side only. A motto must be used instead of the writer's name, and each paper must be accompanied by a sealed envelope bearing the motto outside, and containing the writer's name and address inside.

All communications are to be addressed to the Honorary Secretaries, T. W. E. David and J. H. Maiden, The Society's House, 5 Elizabeth Street, Sydney.

GENERAL.

THE Kansas University Geological Expedition has returned from the field with large and valuable collections of Mesozoic and Tertiary vertebrate fossils, aggregating nearly five tons in weight. Among the material are two complete skeletons of *Bos antiquus*, which will be mounted in the museum; an excellent skull of *Monoclonius (Triceratops)* and a specimen of *Hesperornis*, which is unequalled in any collection for perfection and completeness, and is of especial interest from the fact that the chalk slab upon which it is lying shows clear impressions of the dermal covering.

A FEDERAL DECREE published in the 'Diario Oficial,' on the 25th June, established the metric system of weights and measures obligatory in the United States of Mexico, on and after September 16, 1896. The metric system has been in use in the government departments of Mexico for some time past; the decree makes it the sole legal system throughout the Republic and will do away with the heterogeneous old Spanish measures hitherto tolerated in ordinary business transactions.

AFTER one of the sessions of the Section of Mechanical Science and Engineering of the A. A. A. S. the members were invited to inspect the Duryea motor wagon, and saw the carriage in successful operation. Some of the members rode in it and were delighted with the ease with which the carriage could be managed and the way in which it performed its work. The Messrs. Duryea began their study of this subject in 1886, began construction in 1891, and the present carriage was completed last March. Further improvements have been made which will be embodied in the next one

constructed. The tires are pneumatic and the general appearance of the carriage is very nearly like the ordinary piano-box type.

ON the occasion of the visit of members of the A. A. A. S. to Amherst, Professor Emerson exhibited the important palaeontological, geological and mineralogical collections belonging to the College. Professor Emerson's laboratory and lecture-room was, from a pedagogical point of view, of much interest. One of the appliances was a blackboard constructed on what seems to be a new principle. The face was of ground glass in a hinged frame with a black surface back of the glass. This makes a good blackboard in itself, but its special advantage is that diagrams can be inserted back of the glass, and the drawing can be continued in the presence of the students.

Nature states that a civil list pension of £200 has been granted to Mrs. Huxley.

The Educational Review for September contains three of the principal evening addresses given before the Denver meeting of the National Educational Association:—the Presidential address, by Prof. N. M. Butler, on 'What Knowledge is of Most Worth,' an address by Prof. Joseph Le Conte, on 'Evolution and Education,' and an address by Prof. W. H. Payne, on 'Education According to Nature.' *The Review* also contains the reports of two committees presented to the National Council of Education:—one on the 'Laws of Mental Congruence and Energy applied to some Pedagogical Problems' and one on 'The Rural School Problem.'

THE daily papers contain a telegram from St. John stating that news of the Peary Relief Expedition has been received from the American schooner John E. Mackenzie, returning from the Greenland halibut fishery. The Mackenzie met the Kite with the expedition at Holsteinburg on July 15. At

Holsteinburg the Kite took aboard Professor Dyche, one of the members of the expedition, and sailed again that same evening. Very little ice was reported south of Greenland waters. The crew of the Mackenzie think the Kite will have no difficulty in reaching Whale sound, where Peary's headquarters are located. The return of the relief party is expected about the end of this month.

THE conditions attached to the bequest of \$60,000 made by the late Sir William Macleay to the Sydney University to found a chair of bacteriology are such that the University has decided to decline the bequest. The money will now revert to the Linnean Society to maintain a bacteriologist who will carry on bacteriological investigations and also take pupils.

M. C. H. FRÉMONT described before a recent meeting of the Paris Academy of Sciences a special microscope for the observation of opaque bodies. A concave mirror is placed within the tube of the microscope which reflects a ray of light through the lenses of the objective to the object.

AMONG recent appointments abroad, Professor Strahl, of Marburg, has been called to the chair of anatomy in the University of Giesen; Professor Hans Lenk, of Leipsig, to the professorship of geology in the University of Erlangen; Dr. Haecker, of Freiburg i. B., and Dr. v. Dalla-Torre, of the University of Innsbruck, have been made assistant professors of zoology.

ON August 15th, Dr. Münch, the physicist, died at the age of 75 years. The deaths are also announced of M. H. Wittmeur, professor of mineralogy and geology in the University of Brussels, and of Dr. W. Fabritius, astronomer in the Observatory of Kiew.

La Nature states that an Ethnographical Exposition has been opened at Paris on the Champ-de-Mars by MM. Barbier, exhibit-

ing a negro village of western Africa; not only the inhabitants, but also the manners and customs of the people are represented. The negro families occupy houses grouped according to their race, the architecture being a faithful imitation of the originals. Even native animals and plants have been introduced.

PROF. H. H. POWERS, now of Smith College, has been called to the professorship of economics at Stanford University.

It is stated that Professor Carl Barus has constructed a new top for educational purposes. The 'peg' of the top consists of a writing stylus, adapted to pencil a graphic record of its motions upon a slate or sheet of paper. This motion of the 'peg' simulates the motion of precession about a movable axis which, in its turn, is in both rotational and translational motion. The complex spiral and cycloidal curves which may be thus obtained present an exceedingly beautiful appearance.

THE *American Engineer and Railroad Journal* gives a full account, of the Japanese Industrial Exhibition opened in Kioto on April 1st. The present exhibition is the fourth of a series instituted in 1877 by imperial ordinance of Japan with the object of encouraging the development of agriculture, the arts and commerce. The former exhibitions were held in Tokio in the years 1877, 1881 and 1890. The fourth exhibition is held on the occasion of the eleven hundredth anniversary of the founding of the city of Kioto by Emperor Kwammu. The site for the exhibition is near the incline of the Lake Biwa Canal. The exhibition grounds are 42½ acres in extent. The buildings, eight in number, occupying an area of 305,388 sq. ft. are as follows: Industrial Building, Machinery Hall, Agricultural and Forest Building, Marine Products Building, Aquarium, Fine Arts Building, Live Stock Building and Ceremonial

Hall. The number of exhibits has increased from 16,703 in 1890 to 170,184 in 1895.

DR. LEEBER, Professor of Ophthalmology in the University of Heidelberg, has been awarded the Graefe Medal by the Ophthalmological Congress recently held at Heidelberg.

THE American Electro-Therapeutic Association held its 5th annual meeting at Toronto on September 3d, 4th and 5th.

THE professorship of geology and mineralogy in the University of Toronto is vacant, owing to the resignation of Prof. Chapman.

PROF. PRICE, Commissioner of Fisheries of the Dominion of Canada, has been examining the coast of British Columbia with a view to finding a suitable place for lobster breeding.

PROFESSOR ADAMKIEWICZ, of Vienna, has been elected correspondent of the Paris Academy of Medicine in recognition of his researches on the nature and treatment of cancer.

DURING the month of September there will be held in Hamburg a meeting of the Society of German Physicians for the Insane, and in Stuttgart the annual meeting of the German Society for Public Hygiene.

MR. WILLIAM KENT has become a member of the editorial staff of *Engineering News*.

DR. ALBERT GÜNTHEE, F. R. S., has resigned his position as Keeper of Zoölogy in the Natural History Museum at South Kensington after having filled it for thirty years.

DR. JOHN SYER BRISTOWE, a London physician who achieved great success as a writer, pathologist and clinical teacher, died recently at Monmouth, at the age of 68. His treatise on the 'Theory and Practice of Medicine' first published in 1876 is regarded as one of the leading text-books on the subject and has passed through

many editions. In 1888 he published 'Diseases of the Nervous System,' a collection of papers containing important contributions to neurology.

THERE will be held at Amsterdam on September 20th and 21st an International Congress of Railway and Marine Hygiene. The work of the Congress will be divided into three sections, dealing respectively with the securities for the physical competence of the staffs of railways and ships, the organization of the medical service, and the hygienic interests of employees and travelers.

MR. MARSHALL McDONALD, Head of the United States Fish Commission, died on September 1st, at the age of 60 years.

PROFESSOR SVENON LOUIS LOVEN, a Swedish zoölogist, died recently at the age of 86 years.

PROFESSOR HOPPE-SEYLER, of Strassburg, one of the founders of modern physiological chemistry, died on August 12th, at the age of 70.

We learn from the *British Medical Journal* that in the *Ugeskrift for Læger* Dr. Friis advances a claim on behalf of a Holstein schoolmaster named Peter Plett, to the honour of priority in the discovery of vaccination. Jenner's first vaccination was, he says, performed on May 14th, 1796, but Plett had already done it in 1791. The latter was a tutor in a family at Schönweide in Holstein in 1790, and while there he heard that it was a matter of common knowledge that the milkmaids who had previously been infected with cow-pox never caught small-pox. Having by chance seen a medical practitioner perform inoculation, Plett conceived the idea that cow-pox lymph might be used for the purpose of conferring protection against small-pox. In 1791 he was at Hasselburg, and an epidemic of cow-pox occurring among the cows on a farm, he told the children under his charge to rub their hands with matter from the pus-

tules; as no result followed he himself vaccinated three of them without the consent or knowledge of their parents. He used a table knife for the purpose, making the incisions on the back of the hand, between the thumb and the forefinger. The operation was successful, and a year later, when the other children of the family suffered from small-pox, the three who had been vaccinated by Platt remained free from the disease. There appears to be no record of his having performed other vaccinations.

GINN & Co. announce '*Chemical Experiments—General and Analytical*,' by R. P. Williams, instructor in chemistry in the English High School, Boston. The book contains 100 sets of illustrative experiments, about one-half in general chemistry and one-half in metal and acid analysis.

THE Fifth International Congress for combatting the abuse of alcohol met at Bâle on August 20th, 21st and 23d. The president, M. Heemskirk, the Dutch Minister of State, opened the proceedings by a brief survey of the progress made since the last Congress held at the Hague in 1893. Papers on physiological and psychological effects of alcohol were read and discussed, including an elaborate paper on the effects of different kinds of alcoholic beverages by Dr. Lancelot, delegate of the French Minister of Public Instruction. The second day was devoted to the various anti-alcoholic organizations throughout Europe. On the third day the principal paper discussed the effect of alcoholic abuse in fostering crime. The majority of the members favored total abstinence. Brussels was decided upon as the place of meeting in 1896.

DURING the past ten years the extinction of wolves in France has proceeded rapidly. One hundred and eighty thousand francs were expended by the government in 1894 for the destruction of wolves. In 1895 the total reported is only 2,500 francs. The

official reports state that there are now 55 departments where the presence of wolves is very rare.

It is stated that the report of the death of M. Lucien Bonaparte Wyse is incorrect, his name having been substituted for that of his brother, M. Napoleon Alfred Wyse.

At the last meeting of the Council of Manchester Museum, Owens' College, as reported in *The Lancet*, the library committee recommended that a grant of £400 per annum be made on condition that the Lancashire and Cheshire County Councils and the local district councils gave £800 a year. As an amendment it was proposed that the £400 should in any case be given.

CORRESPONDENCE.

WINDS AND OCEAN CURRENTS.

THE article by Mr. Bache in a recent number of SCIENCE on the causes of the Gulf Stream brings up a number of points on which other opinions than those which he advocates may be fairly maintained. Some of these points have been indicated by Prof. Le Conte (SCIENCE, Aug. 16). The scheme of a northeast surface movement and southwest subsurface return of an oceanic circulation in the northern hemisphere, if uninterrupted by continents, is essentially a return to the untenable view advocated by Dove in his theory of atmospheric circulation; now displaced by Ferrel's much more satisfactory theory. The deducible circulation of the ocean, under convectational control alone, whether interrupted by continents or not, has been best stated by Ferrel, especially in several articles in SCIENCE, first series, 1886 or 1887; my file is not now at hand for precise reference.

While there is good reason to believe that the difference of density of the equatorial and polar waters produces a slow convectational circulation of the ocean, and is responsible for the low temperature of the great body of the torrid oceans, there is also good reason for thinking that the comparatively rapid and notably systematic, eddy-like circulation of the surface waters in the several oceans is determined essentially by the winds. The argu-

ments for the wind theory, as generally stated, are first, the general accordance of prevailing winds and associated currents; each ocean having its wind eddy only less marked than its current eddy. Second, the periodic variation of the currents in regions of monsoon winds; the type example of this kind being in the Indian Ocean, where, as even Dampier noted two hundred years ago, the currents shift about a month after the winds. Third, the irregular movements of the surface waters under storm winds, which suffice in a day or two to deflect or even to reverse the surface layers of so strong a current as the Gulf Stream off Hatteras. To these facts may be added the hardly less significant behavior of the equatorial counter currents, which increase in area and strength on that side of the equator to which the trade wind from the other hemisphere crosses over as a deflected, monsoon-like wind; the monsoon currents of the Indian Ocean being only special cases of this general rule. The greater velocity of the North Atlantic drift ('North connecting current' in the objectional terminology of the school atlases) in winter than in summer may also be mentioned as a fact best explained by the wind theory. There is nothing about the Gulf Stream so peculiar as to exempt it from the general control exercised by the winds over the waters.

W. M. DAVIS.

HARVARD UNIVERSITY.

CORRECTIONS.

EDITOR OF SCIENCE: The fate of my review of Beddard's Zoogeography furnishes another illustration of the dangers which an author is subject to in his path to publication. In the proof (of which I have a duplicate at hand), Nearctic and *Osteolæmus* occur all right, but in the published article (altered after it passed through my hands) *Osteolæmus* is substituted for *Ostolæmus* and *Osteolæmus* for *Osteolæmus* and consequently there is no apparent point to the criticism made and no reason for the analogue *event*. 'Upiform' on p. 273 (left column) should have been *pupiform*, and 'even' on p. 273 (right column) just before 'the same Hyracodon' should, of course, have been *event*. The *p* of *pupiform* and *t* of *event* were dropped after

transmission of the proof; 'molacologist' should have been corrected to *malacologist*.

I may add that Mr. Beddard spells the title of his volume Zoogeography (without *o*) as I had written and corrected.

The reviewer of Beddard's work in 'Nature' (July 25, p. 289) is "at a loss to understand" "by what confusion of ideas the name *Hyracodon*, (which belongs to an extinct genus of rhinoceros-like animals) is made to do duty for *Didelphys*." *Hyracodon* of Tomes, as noted in the review in SCIENCE (p. 273) was published in 1863 and in the Proc. Zoöl. Soc. London (p. 50) and has remained unexplained to the present day. I have long been inclined to believe that it was based on a young *Didelphys*, although the meagre description does not apply to any stage I have seen (and I have seen many). I was surprised that it was not noticed in Mr. Thomas' excellent work on Marsupials. It seems, indeed, to have fallen quite flat, but was noticed by Murray in his geographical distribution of Mammals, and I presume that it is from Murray that Mr. Beddard has received the generic name. The homonymy of the names of Leidy and Tomes was, of course, a mere coincidence. The type of Tomes' genus (*Hyracodon fuliginosus*) was from 'Ecuador; collected by Mr. Fraser.' If it has not been lost, perhaps Mr. Thomas may find it and tell us what it is.

We may, perhaps, derive some comfort from the fact that the printers of your famous contemporary 'Nature' are by no means exempt from errors like those I now correct. Four lines before the reference to *Hyracodon* just cited, we find a reference to the 'Siberian hippopotamus;' the original copy of the review undoubtedly had *Liberian*. THEO. GILL.

WASHINGTON, Aug. 31, 1895.

[In the issue of SCIENCE for August 30, smaller type was for the first time used in part of the number. As is apt to happen in such cases there was a delay in the arrival of the type and the proof was late. Dr. Gill's corrections were sent to the printer, but the corrected proof was not seen by the editor. The errors are however such (presumably due to resetting part of the article) that it is better to offer apologies rather than excuses. J. McK. C.]

BOLOMETRIC INVESTIGATIONS; A CORRECTION.

PROF. JOSEPH LE CONTE has kindly called my attention to an error in the above article. On page 175, 7 lines from the bottom of first column, it should read million instead of thousand, and after line 5 insert million, that is, the limits are four hundred million million and seven hundred million million times per second. The error was made in transcribing the original manuscript and was not caught in my proof reading.

WILLIAM HALLOCK.

SCIENTIFIC LITERATURE.

The Growth of U. S. Naval Cadets. By HENRY G. BEYER. (Proceedings of the United States Naval Institute, Vol. XXI., No. 2. Whole No. 74).

In this paper Dr. Henry G. Beyer discusses measurements of U. S. Naval Cadets. These measurements form an exceedingly valuable material for the study of growth. The character of the material may be judged from the following remarks of the author:

"It has been the custom at the Naval Academy for the last thirty years or more to make an annual physical examination of every cadet in training at that school, and, at the same time, to keep a record of certain anthropometric measurements of every cadet undergoing such examination. * * * Up to a few years ago the height standing, perineal height, circumference of chest, waist measure and the lung capacity were the only items recorded. Within recent years the height sitting, span of arms, strength of squeeze, acuteness of vision and hearing have been added to these records; the number of observations under the first-named items is, consequently, much larger than that under the last named. * * * The cadet who stays the full term of four years at this school leaves on the books the records of five successive examinations taken one year apart; after graduation two years are spent at sea, after which time the cadet returns to the Academy for his final examination, leaving the records of another physical examination. This makes six in all. Since the age for entrance into the Academy is limited to from 15 to 18 years, and taking six years as the time necessary to elapse between the first and last examinations, the period of growth

covered by these records ranges all the way from 15 to 24 years of age."^{*}

The most important part of the investigation is the discussion of individual growth which proves beyond a doubt that the assumption which was made by Bowditch and Porter, namely, that on the average individuals of a certain percentile rank retain this rank through life does not hold good. Dr. Beyer considers boys of 15 years of age and representing the 25th and 75th percentile grades. It appears from the tables given by the author that the average statures of both classes approach more and more the 50th percentile grade. I have computed the rank of these boys from year to year from the statements given by Dr. Beyer, and obtained the result that boys who ranked at 15 years 26% and 73% ranked in the following years:

| | | | | | | | |
|------------|----|----|----|----|----|----|----|
| Years..... | 15 | 16 | 17 | 18 | 19 | 20 | 21 |
| Grade..... | 26 | 28 | 26 | 34 | 27 | 38 | 38 |
| Grade..... | 73 | 74 | 69 | 69 | 68 | 65 | — |

It appears that the approach of the lower grade towards the middle is greater than that of the higher grade. In the consideration of weight the approach of the lower grade toward the middle grade appears even stronger, while the higher grade even exceeds the corresponding normal grade. It is difficult to understand the reason of this phenomenon. It would seem likely that when we select a certain grade at a certain age, and follow the development of the individuals composing the grade, that the conditions of life during the following years are favorable in some cases, unfavorable in others, but, on the whole, correspond to the average conditions. When, therefore, the initial age is remote from the adult stage, we should expect a gradual approach to the average. This phenomenon is observed in the case of stature, but does not appear clearly in the case of weight. As Dr. Beyer does not give his original observations, it is impossible to judge what may be the cause of this curious fact.

The same subject is treated in a small but useful table (XVII.), which proves that when a small group of individuals whose statures at

* In addition to these data we should like to know the restrictions governing the selection of cadets which are of great importance in interpreting the observed distribution of measurements.

a certain age lie between narrow limits are treated alone, the variability of the series increases steadily until the adult stage is reached, and that furthermore this increase in variability is the less the nearer the initial point approaches the adult stage. It appears at the same time that each of these series approaches the middle values as time elapses from the initial age.

Another important phenomenon which is brought out in this paper is that tall boys of 16 years grow much less than short boys, because they are nearer the adult stage. As the table which Dr. Beyer gives is rather complex and not quite clear, I have computed it again and give it here in a modified form. I have compensated the series and find that among each 100 boys the following amounts of total growth occur :

| Statures at 16 years. | 62 and 63 in. | 64 and 65 in. | 66 and 67 in. | 68 and 69 in. |
|--|---------------|---------------|---------------|---------------|
| Frequency of various amounts of total growth from 16th to 22d year in inch. among 100 individuals. | | | | |
| -0.9-0.0 | — | 1 | — | 2 |
| +0.0-0.9 | 3 | 9 | 15 | 14 |
| 1.0-1.9 | 8 | 24 | 35 | 39 |
| 2.0-2.9 | 14 | 32 | 31 | 31 |
| 3.0-3.9 | 17 | 21 | 12 | 12 |
| 4.0-4.9 | 18 | 10 | 2 | 2 |
| 5.0-5.9 | 17 | 2 | 1 | — |
| 6.0-6.9 | 10 | 1 | 3 | — |
| 7.0-7.9 | 5 | — | 1 | — |
| 8.0-8.9 | 6 | — | — | — |
| 9.0-9.9 | 2 | — | — | — |

These figures show that the typical amount of growth of the 16-year-old boy who is 62 or 63 inches tall is about 4.4 inches ; of the boy who is 64 or 65 inches tall 2.4 inches, and of those from 66 to 69 inches only 1.8 inches. It also shows that the boys grow more uniformly the taller they are, and this is probably the cause of the more rapid approach of the lower grades towards the middle values. The curves showing the total amount of growth are necessarily very asymmetrical and the asymmetry effects the averages of the statures of the boys who originally belong to the same grade. Therefore these averages which were used by Dr. Beyer in following the growth of a certain group of individuals are only very rough approximations to the

typical value of that class. For the 17th year I obtained the following distribution and approximate typical values of growth from the 17th to the 22d year of age :

| Stature at 17 years. | 64 and 65 in. | 66 and 67 in. | 68 and 69 in. |
|---|---------------|---------------|---------------|
| Frequency of various amounts of total growth from 17th to 22d year among 100 individuals. | | | |
| -0.9-0.0 | 3 | 5 | 5 |
| +0.0-0.9 | 22 | 35 | 42 |
| 1.0-1.9 | 31 | 38 | 42 |
| 2.0-2.9 | 25 | 16 | 9 |
| 3.0-3.9 | 10 | 5 | 1 |
| 4.0-4.9 | 4 | 1 | 1 |
| 5.0-5.9 | 5 | — | — |
| Typical growth from 17th to 22d year; inches. | 1.6 | 1.0 | 0.3 |

This consideration cannot be carried on, because the selection made by the author of individuals of equal stature of 16 years of age influences the distribution of measurements taken during the later years too much.

It appears from these tables that it would be an easy matter to determine in this manner, how many individuals of each class are adult at a certain age, and this is one of the fundamental points required for a better understanding of the laws of growth. But it would have been much better to start with individuals who as adults have the same measurements and to investigate how these measurements are distributed in earlier years. This is the only means by which the difficulties arising from the irregular distribution of the period of growth in different individuals can be overcome.

The investigation suffers greatly from the fact that only a selection—and not a very systematic selection—of data from the rich material has been utilized. The author deserves our special thanks for having given these data in an unbridged form. They are contained in Tables XIV. to XVI., which represent the heights of 63 tall, 71 middle-sized, and 52 short individuals, measured mostly annually from their 16th to their 22d year, but the measurements for the 21st year are missing in most cases. The grouping, however, is not favorable, the limits of the lowest and highest classes being too wide. The shortest class contains individuals of from 60.5

to 65½ inches; the middle-sized group individuals measuring 65 and 66 inches, the tall group individuals of from 67 to 69.5 inches. In arranging such a table either the total material must be utilized or a certain portion selected at random, and the limits which are originally selected must be adhered to most rigidly. Therefore it is not admissible to include in these tables individuals whose measurements at 16 years are not given but whose later development is similar to that of other boys of the class. The deviations of these three tables which are given at the foot of the columns have been miscalculated.

It is very curious that although the paragraphs discussed here show that the theory of percentile grades as applied to the study of growth cannot be held any longer, nevertheless the whole valuable material is presented in this form so that it is all but useless for the purpose of further investigations. The very conclusions which the author draws from his study of individual records prove that all the tables (XXIX. to XLVIII.) which contain the annual increases for the different percentile grades have no biological significance whatever and ought to have been omitted.

Dr. Beyer's investigations show that it is quite indispensable to publish the original records of each individual as the only means of really furthering our knowledge of the laws of growth. Only on such tables can future study be founded, and if there is to be a wholesome advance in the science of anthropometry such tables must be accessible to all. We hope that the author may find an opportunity of extending the brief abstracts of such individual records which are printed in tables XIV. to XVI. and give us the whole valuable material which would represent the most important contribution to the study of growth made for a long time.

FRANZ BOAS.

Untersuchungen über die Stärkekörner; Wesen und Lebensgeschichte der Stärkekörner der höheren Pflanzen. Von ARTHUR MEYER, Professor der Botanik an der Universität Marburg. Mit neun Tafeln und 99 in den Text gedruckten Abbildungen.

As the title suggests, this work contains an

exhaustive treatment of the subject. Its principal interest lies in the fact that the manner of origin and growth of the starch grain has been for many years a subject of patient investigation, and different theories respecting the unit of organized structures have been based on the facts thus obtained.

The work is divided into five parts. The first treats of the chemical nature of the starch grain, its relation to the action of the ferment diastase; the second, of the physical character of the grain; the third, of its biology; the fourth consists of biological monographs of the starch grains of various plants; the fifth is a short discussion of the relation of the starch grain to the living protoplast.

In order to make clear the conclusions reached by the author in the first part, it will be necessary to explain that Naegeli was the first to construct a theory concerning the chemical nature of the starch grain, its manner of origin and subsequent growth. Since his book was written many facts have come to light, which have invalidated some of his conclusions. His work, however, forms the basis of all subsequent investigations. He considered the grain made up of two substances which he named starch cellulose and granulose. The latter he thought contained the essential principles of starch, and is that part which is dissolved by the action of saliva on certain acids; the former he supposed differed but little from the substance composing the principal part of the vegetable cell wall, or cellulose; this starch cellulose forms the skeleton or framework left after the grain has been treated with saliva or acids as before described. Later investigators, among whom is Walter Naegeli, claim that the intact grain consists of one substance only, and that the skeleton is the product of the chemical action of the acids on this substance, and they name this product amyloextrine.

According to the results obtained by the author in a long series of experiments, he concludes that the grain consists of one substance, amylose, which exists in two forms or modifications, and a slight amount of another substance, amyloextrine, which is a dissociation product of amylose. The two forms of this latter substance he names for convenience β - and α -

amylose, and says it is quite possible that future investigations will show that β - and α -amylose are crystals of one and the same substance, the former containing water, the latter without. Of the difference between them, he says β -amylose is soluble in water at 100° , while α -amylose requires a greater degree of heat to render it soluble, and that if the starch grain be treated with water at 138° a single substance may be obtained in the form of β -amylose as the α -amylose is changed to this form.

Amylodextrine is said to be of interest for three reasons. First, it exists in those starch grains which turn red with the application of iodine; second, the ordinary starch grain can be easily changed into it; third, because the sphaerocrystal of the pure amylodextrine is very important in explaining the real nature of the starch grain. The first discoverer of amylodextrine was Musculus (Comptes rendus 1870, page 857), who named it insoluble dextrine. Its present name was given it by Walter Naegeli, who, with many other scientists, afterwards obtained this substance by treating starch with various acids. The author conducted a series of similar experiments for the purpose of obtaining amylodextrine in a pure form and then to determine its molecular weight. He succeeded in the former, but in the latter attempt only learned with certainty that its molecular weight was very high. He then gives in detail the exact methods and results of a long series of experiments with various substances more or less clearly related to amylodextrine. Among other conclusions concerning it he states that the skeleton of the starch grain, obtained by treating it with saliva or acids, does not consist entirely of amylodextrine as was formerly supposed, but of a mixture of crystals of this substance with crystals of α -amylose. Part first closes with the macro- and micro-chemistry of the starch grain.

In the second chapter he gives a statement of his conclusions concerning the physical constitution of the starch grain, with an explanation of his reasons, then a full account of all the theories preceding his own. It is impossible to give more than a brief summary of the contents of this chapter in the space allotted to a review.

Naegeli's theory, as the author states, was the first which was founded on an extended series of observations, and from the year it was published, 1858, till now, it has been the prevailing theory with most scientists and text-book writers. According to our author, however, it has wrought much harm by introducing the use of the terms, intussusception and apposition as applied to methods of growth, also by the application of the supposed manner and growth of the starch grain to that of cell wall and protoplasts. Schimper, in his work published in 1880 and 1881, was the first to destroy the deep-seated faith in Naegeli's theory. This he did first, by proving that most starch grains are formed in the chromatophores, while the foundation of Naegeli's theory rests on the assumption that the starch grain grows free in the cell sap. Second, Schimper claimed that the inner part of the grain is the older, the outer the younger. His conclusion is that the starch grain is a sphaerocrystal composed of fibrous crystalloids, therefore the whole is a crystalloid. The author contrasts the opinions of Naegeli and Schimper as follows: Naegeli supposed the grain to be made up of long crystals lying perpendicular to the layers of stratification, but free in the cell sap. Schimper supposed the crystalloid threads composing the grain to be united at their bases. Naegeli made the spherical bodies or balls, forming the transition between fluid and solid bodies, grow by means of the intercalation of new substances between the old particles; Schimper, by the superposition of new masses of substance. Naegeli explained the layers as resulting from a difference in tension caused by the new particles of substance intercalated between the old, Schimper, by a difference in tension caused by the influx of water between the particles of substance. It is in this particular, and in other characters of the grain which Schimper claimed as a cause for its striations, that his theory differs from that of the author.

According to the latter, the starch grain is a sphaerocrystal (not a sphaerocrystalloid) composed of crystals of β - and α -amylose and amylodextrine. He defines the word sphaerocrystal in the sense in which it was used by Naegeli and Rosenbusch, that is, a microscopically small spherical body with a more or less

plainly radial structure, and more or less clearly marked striations, and which shows a cross when viewed with a polarizer. These bodies exist in the mineral, animal and plant kingdoms, and may be artificially produced from organic or inorganic material. The author claims that the starch grains are sphaerocrystals which are exactly similar in structure and action to those of other carbohydrates, with the single exception of their manner of swelling in the formation of paste. This difference he attributes to the peculiarity of the β -amylose crystals, and says it is too unimportant to make a distinction between the starch grain and the sphaerocrystal. The typical sphaerocrystal consists of very fine, long, needle or thread-like crystals which may be called trichiten. These trichiten are united in clusters and the clusters branch in such a manner as to form pores or channels for the entrance of water. The manner of branching depends upon certain conditions in the way the material by which the crystal grows is furnished. The appearance of stratification is caused by the difference in the size of the pores, and consequently the amount of water in the different layers. In all this the starch grain corresponds to the sphaerocrystal of the pure amyloextrine, both bodies enlarging to a certain extent on taking in water. It is otherwise when heat or chemical reagents are used, by which the starch grain is partially dissolved. This he terms 'Lösungsquellung,' a process peculiar to starch and due to the nature of β -amylose. In conclusion he adds, as the structure of the starch grain corresponds to that of the sphaerocrystals of other carbohydrates it is highly probable that it grows in the same manner.

The result of the author's investigations concerning the biology of the starch grains must also be condensed into a few sentences. He describes the chromatophore as a drop of a complex viscous fluid solution. In the viscous fluid of this drop the carbohydrates are formed and eventually condensed to amylose, etc. The form of the starch grain depends upon the form of this drop. It is also influenced largely by the diastase which is in the chromatophore itself and works principally from the outside inward so that the grain grows smaller by its action. He claims that starch grains may be formed in

the three different kinds of chromatophores, and that in the angiosperms, at least, they never originate free in the cell sap or cytoplasm. He describes the chloroplast as consisting of a colorless or yellowish substance, stroma, in which lay drops of a chlorophyll-colored substance, grana. He suggests that the latter form the apparatus of assimilation, while the stroma produces the starch and is also the organ by which diastase is formed. The growth of the starch grain is said to be influenced considerably by the formation of crystalloids of proteid substances which the chromatophores are known to form. He suggests that the names of the various kinds of grains, given to them by Naegeli, be changed to others more in harmony with their manner of growth. Numerous examples are given from various plants, and the experiments of a large number of scientists are quoted in addition to his own; to explain the cause of rifts and clefts in certain grains, the origin of the layers and many other points.

Finally, he treats of the starch grain as a part of the living protoplast. After contrasting the views of Naegeli and Wiesner by which they formulated hypotheses concerning the organization of the cell, he says both these scientists hold that there is no important difference between the structure of the starch grain and that of protoplasm. An entirely different relation, however, between starch grain and protoplast must be assumed by all who consider the protoplast a fluid. He then quotes from a large number of scientists who agree with him in this opinion of protoplasm.

If this view of the nature of the starch grain be correct, the commonly accepted theory concerning the unit of structure of cell wall and of protoplasm loses its foundation. It is true that the greater part of Naegeli's studies was confined to the starch grain, while other botanists applied these conclusions to the structure and manner of growth of cell wall and even to the unit of structure of the living protoplasm. It is highly probable that, as a German botanist said to the writer of this review, referring to another contested physiological problem, "The last word concerning this subject has not been spoken."

EMILY L. GREGORY.

SCIENCE

NEW SERIES.
VOL. II. No. 38.

FRIDAY, SEPTEMBER 20, 1895.

SINGLE COPIES, 15 CTS.
ANNUAL SUBSCRIPTION, \$5.00.

GUSTAV E. STECHERT'S Recent Importation of Scientific Books.

BECKERT, TH. and DR. ALBANO BRAND. Hüttenkunde. Mit 235 in den Text gedruckten Figuren. 765 Seiten. gr. 8°. Mk. 20.

BEHRENS, H. Anleitung zur mikrochemischen Analyse. Mit einem Vorwort von Prof. S. Hoogewerf in Delft. 224 Seiten mit 92 Figuren in Text. 8°. Mk. 6.

BIEDERMANN, W. Elektrophysiologie. 1^{te} Abtheilung. Mit 136 Abbildungen. 440 Seiten. 8°. Mk. 9.

BORCHERS, DR. W. Elektro-Metallurgie. Die Gewinnung der Metalle unter Vermittlung des elektrischen Stromes. 2^{te} verm. v. völlig umgearb. Auflage. 1^{te} Abtheilung, mit 87 Abbildungen. 160 Seiten. gr. 8°. Mk. 6⁰⁰.

BUSCHAN, GEORG. Vorgeschichtliche Botanik der Cultur-u. Nutzpflanzen der alten Welt auf Grund prähistorischer Funde. 268 Seiten. 8°. Mk. 7⁰⁰.

DAMMER, DR. O. Handbuch der chemischen Technologie. Unter Mitwirkung von Direktor Th. Beckert, Dr. Bender, Dr. Benedikt, Dr. Börnstein u. A. herausgegeben. 2^{ter} Band. Mit 235 in den Text gedruckten Figuren. gr. 8°. Mk. 20.

DELAGE, YVES. La structure du protoplasma et les théories sur l'hérédité et les grands problèmes de la biologie générale. 878 pages. gr. 8° cloth. frs. 24⁰⁰.

DETMER, DR. W. Das pflanzenphysiologische Praktikum. Anleitung zu pflanzenphysiolog. Untersuchungen für Studierende u. Lehrer der Naturwissenschaften, sowie der Medicin, etc. 2^{te} völlig neubearbeitete Aufl. Mit 184 Abbildungen. 456 Seiten. 8°. Mk. 9.

FOREL, DR. AUGUST. Der Hypnotismus, seine psycho-physiologische medicinische, strafrechtliche Bedeutung und seine Handhabung. 3^{te} verb. Aufl. mit Adnotationen von Dr. O. Vogt. 223 Seiten. gr. 8°. Mk. 5.

FRANK, DR. A. B. Die Krankheiten der Pflanzen. Ein Handbuch für Land u. Forstwirte, Botaniker, etc. Erster Band, Die durch organ. Einflüsse hervorgerufene Krankheiten. Mit 34 Holzschnitten. 2^{te} Aufl. 344 Seiten. 8°. Mk. 6⁰⁰.

HIS, WILH. Die anatomische Nomenclatur. Nomina anatomica, Verzeichniss der von der anatomischen Gesellschaft auf ihrer 9. Versammlung in Basel angenommenen Namen. Mit 30 Abbildgn. im Text und 2 Tafeln. 180 Seiten. Mk. 7⁰⁰.

HOUDAILLE, F. Météorologie agricole. 204 pages cloth. fr. 3.

JAHRBUCH DER ELEKTROCHEMIE. Berichte über die Fortschritte des Jahres 1894. Im wissenschaftlichen Theile bearbeitet von Dr. W. Nernst. Im technischen Theile bearbeitet von Dr. W. Borchers. I^{er} Jahrgang. 274 Seiten. gr. 8°. Mk. 10.

JERUSALEM, WILH. Die Urtheilsfunction. Eine psychologische und erkenntniskritische Untersuchung. 269 Seiten. Mk. 6⁰⁰.

LOEWY, DR. A. Untersuchungen über die Respiration and Circulation bei Aenderung des Druckes und des Sauerstoffgehaltes der Luft. Mit 5 Curventafeln im Text. 155 Seiten. gr. 8°. Mk. 4.

MEYER, DR. ARTH. Untersuchungen über die Stärkekörner der höheren Pflanzen. Mit 9 Tafeln u. 99 Text-Abbildgn. 318 Seiten. gr. 8°. Mk. 20⁰⁰.

NIEDENZU, DR. FRANZ. Handbuch für botanische Bestimmungsübungen. Mit 15 Figuren im Text. 351 Seiten. 8°. Mk. 4.

SCHAFFER, DR. KARL. Suggestion und Reflex. Eine Critisch-experimentelle Studie über die Reflexphänomene des Hypnotismus. Mit 6 Tafeln in Lichtdruck und 11 Abbildungen im Text. 113 Seiten. gr. 8°. Mk. 6⁰⁰.

SCHMIDT, DR. ALEX. Weiters Beiträge zur Blutlehre. Nach des Verfassers Tode herausgegeben. 247 Seiten. 8°. Mk. 7.

SCHWARTZE, TH. Die Lehre von der Electricität und deren praktische Verwendung. Mit 153 in den Text gedruckten Abbildungen. 543 Seiten. 8°. Mk. 10⁰⁰.

STEINHARDT, DR. EUGEN. Kurzes Lehrbuch der Chemie zum Gebrauch an Schulen und zur Selbstbelehrung. Zwei Theile. Erst. Teil; Anorganische Chemie. 418 Seiten. 8°. Mk. 6⁰⁰.

VAN BIERVLIET, J. J. Elements de psychologie humaine. Cours professé à l'université de Gand. Avec 34 figures dans le Text. 317 pages. frs. 8.

ZEITSCHRIFT FÜR ANGEWANDTE MIKROSKOPIE herausgegeben von G. Marpmann. Monthly. 1^{er} Band 1^{er} Heft. Per year, \$2.75.

ZEITSCHRIFT, Geographische, Herausgegeben von Dr. Alfred Hettner. 1^{er} Jahrg. 1^{er} Heft. Pery year (12 N^{os}) \$4⁰⁰.

ZIMMERMANN, DR. A. Das Mikroskop. Ein Leitfaden der wissenschaftlichen Mikroskopie. Mit 231 Figuren im Text. 334 Seiten. gr. 8°. Mk. 9.

ZITTEL, KARL A. VON. Grundzüge der Paläontologie (Paläozoologie). Mit 2048 in den Text gedruckten Abbildungen. 971 Seiten. gr. 8°. ½ mor. Mk. 25⁰⁰.

GUSTAV E. STECHERT,

810 Broadway, New York.

Macmillan & Co.'s New Publications

NEW VOLUME OF THE

Columbia University Biological Series.

Edited by HENRY FAIRFIELD OSBORN, *Da Costa Professor of Biology in Columbia College.*

Fishes, Living and Fossil.

An Outline of their Form and Probable Relationship.

By BASHFORD DEAN, Ph. D. Columbia, *Instructor in Biology, Columbia College.*

With Illustrations from the Author's original Pen Drawings. 8vo, cloth, \$2.50 net.

ALREADY PUBLISHED IN THE SAME SERIES.

From the Greeks to Darwin. The development of the evolution idea. By HENRY FAIRFIELD OSBORN, Sc. D. Princeton, *Da Costa Professor of Biology in Columbia College.* 8vo, cloth, \$2.00 net.

Amphioxus and Ancestry of the Vertebrates. By ARTHUR WILLEY, B. Sc. Lond., *Tutor in Biology, Columbia College, Balfour Student of the University of Cambridge.* With Illustrations. 8vo, cloth, \$2.50 net.

NEW VOLUME.

Columbia University Press.

Atlas of the Fertilization and Karyokinesis of the Ovum.

By EDMUND B. WILSON, Ph. D., *Professor of Invertebrate Zoology in Columbia College*, with the cooperation of EDWARD LEAMING, M. D., F. R. P. S., *Instructor in Photography at the College of Physicians and Surgeons, Columbia College.* Illustrated with 40 figures photographed from nature by Dr. Leaming, from the preparations of Professor Wilson at an enlargement of one thousand diameters, and mechanically reproduced by the gelatine process without retouching, by Edward Eierstadt of New York. The plates are accompanied by an explanatory text, giving a general introduction to the subject for the use of students and general readers, a detailed description of the photographs, and over sixty text-figures from camera-drawings. 8vo, cloth, \$4.00 net.

Hertwig.—The Cell: Outlines of General Anatomy and Physiology.

By DR. OSCAR HERTWIG, Professor Extraordinarius of Anatomy and Comparative Anatomy, Berlin. Translated by M. CAMPBELL and Edited by HENRY JOHNSTONE CAMPBELL, M. D., Assistant Physician to the City of London Hospital for the Diseases of the Chest, etc. With 168 Illustrations. 8vo, cloth, pp., \$3.00 net.

Lindsay.—An Introduction to the Study of Zoology.

By B. LINDSAY, C. S. of Girton College, Cambridge. With 124 Illustrations and Diagrams. Pp. xix+356, 12mo, cloth, \$1.60 net.

Cooke, Shipley and Reed. Molluscs and Brachiopods.

By REV. A. H. COOKE, M. A., Fellow of King's College, Cambridge; A. E. SHIPLEY, M. A., Fellow of Christ's College, Cambridge; and F. R. C. REED, B. A., Trinity College, Cambridge. Illustrated. *Cambridge Natural History.* 8vo, cloth, pp. 535, \$3.25 net.

"Written in the true spirit of the Alpine Climber."

The Alps from End to End.

By SIR WILLIAM MARTIN CONWAY. With 100 Illustrations by A. D. MCCORMICK. Large demy, 8vo, cloth, \$7.00.

The Rural Science Series.

Edited by L. H. BAILEY. New Volume.

King.—The Soil. Its Nature, Relations and Fundamental Principles of Management. By F. H. KING, Professor of Agricultural Physics in the University of Wisconsin. 16mo, cloth, 75 cents.

Jackson.—The Great Frozen Land. Narratives of a Winter Journey across the Tundras and a Sojourn among the Samoyads. By GEORGE F. JACKSON, Fellow of the Royal Geographical Society and Leader of the Jackson-Harmsworth Polar Expedition. With Illustrations and Maps. Edited from his Journals by ARTHUR MONTEFIORE. 8vo, cloth, pp. xviii + 297, \$4.50.

Wright.—Birdcraft. A Field Book of Two Hundred Song, Game and Water Birds. By MABEL OSGOOD WRIGHT. With numerous full-page Plates containing 128 Birds in the Natural Colors, and other Illustrations. 8vo, bound in linen, \$3.00 net.

"An Arctic Adventure."

Ice-Bound on Kolguev. By AUBYN TREVOR-BATTYE, F. L. S., F. Z. S., etc. With numerous Illustrations and Drawings, and 3 Maps. Large 8vo, cloth, gilt top, \$7.00.

MACMILLAN & CO., 66 Fifth Avenue, New York.

SCIENCE

EDITORIAL COMMITTEE: S. NEWCOMB, Mathematics; R. S. WOODWARD, Mechanics; E. C. PICKERING, Astronomy; T. C. MENDENHALL, Physics; R. H. THURSTON, Engineering; IRA REMSEN, Chemistry; J. LE CONTE, Geology; W. M. DAVIS, Physiography; O. C. MARSH, Paleontology; W. K. BROOKS, Invertebrate Zoology; C. HART MERRIAM, Vertebrate Zoology; S. H. SCUDDER, Entomology; N. L. BRITTON, Botany; HENRY F. OSBORN, General Biology; H. P. BOWDITCH, Physiology; J. S. BILLINGS, Hygiene; J. McKEEN CATTELL, Psychology; DANIEL G. BRINTON, J. W. POWELL, Anthropology.

FRIDAY, SEPTEMBER 20, 1895.

CONTENTS:

| | |
|---|-----|
| <i>Springfield Meeting of the American Association for the Advancement of Science</i> | 349 |
| <i>Section B. Physics</i> : WILLIAM HALLOCK. <i>Section C. Chemistry</i> : W. A. NOYES, A. H. GILL, FRANCIS C. PHILLIPS. <i>Section D. Mechanical Science and Engineering</i> . | |
| <i>Development of Vegetable Physiology</i> : J. C. ARTHUR..... | 360 |
| <i>Current Notes on Physiography (XVI)</i> :—..... | 373 |
| <i>National Geographic Monographs; The Composite Origin of Topographic Forms; Tidal Streams about the British Isles; Meteorological Charts of the Red Sea</i> : W. M. DAVIS. | |
| <i>Preliminary Note on a Contagious Insect Disease</i> : S. A. FORBES..... | 375 |
| <i>Scientific Notes and News</i> | 376 |
| <i>University and Educational News</i> | 378 |
| <i>Correspondence</i> :—..... | 379 |
| <i>Are Consequences Ever a Test of Truth?</i> JOSEPH LE CONTE. <i>The Katydid's Orchestra</i> : GEORGE M. GOULD. | |
| <i>Scientific Literature</i> :—..... | 381 |
| <i>Foster's Physiology</i> : W. T. PORTER. <i>Nehrling's North American Birds</i> : C. H. M. | |
| <i>Scientific Journals</i> :..... | 383 |
| <i>The American Geologist; The Astrophysical Journal</i> . | |
| <i>New Books</i> | 384 |

MSS. intended for publication and books, etc., intended for review should be sent to the responsible editor, Prof. J. McKeen Cattell, Garrison on Hudson, N. Y. Subscriptions and advertisements should be sent to SCIENCE, 41 N. Queen St., Lancaster, Pa., or 41 East 49th St., New York.

SPRINGFIELD MEETING OF THE AMERICAN ASSOCIATION FOR THE ADVANCEMENT OF SCIENCE.

SECTION B. PHYSICS.

THE address of the Vice-President, Prof. W. Le Conte Stevens, was upon 'Recent

Progress in Optics.' He introduced the subject by referring to the impossibility of summarizing all of the work, even of a meritorious order, that has been accomplished, and preferred to discuss certain investigations of special merit. First among these was the standardizing of the metre in terms of a wave-length of light, an investigation begun by Michelson and Morley eight years ago, and recently completed by Michelson at the observatory of the International Bureau of Weights and Measures near Paris. A brief description was given of the construction and use of the interferential comparer, and the difficulties encountered in securing a perfectly homogeneous spectrum tint. Spectral lines that had been supposed to be single, and hence due to approximately homogeneous light, were found to be multiple, presenting the phenomenon of optical beats, or maxima and minima of brightness in the interference fringes that pass across the field of view in the observing telescope. So delicate is the method that it is possible to detect a variation of wave-length corresponding to as little as one-thousandth of the interval between the two main components of what is commonly known as the sodium line. The red line of cadmium was found the most nearly simple of all those examined, and the length of the standard meter was determined to be 1,553,163.5 wave-lengths of cadmium light. This was the mean of two independent

determinations differing from it about one part in two millions. This achievement is deemed a signal scientific triumph that ranks with the brilliant work of Arago, Fresnel and Regnault. In the conception, mechanical design and execution it is wholly and distinctively American; and it tends to do away with the reproach, too often deservedly cast against America, that our people have little appreciation for scientific work unless its value can be expressed in dollars.

The subject of luminescence was next taken up, in connection with important work done in Germany, by Wiedemann and Schmidt, and not yet fully published, with a view to clearing up the uncertainties regarding the nature of this in its two chief manifestations, phosphorescence and fluorescence. We have here, as in photography, a transformation of radiant energy; and it is shown that in a large proportion, if not all, of the cases examined, at least a part of the transformation is into chemical energy, to which is superadded the retransformation into energy of longer period; and this either at the same time or long after the action of the exciting rays. Many substances which manifest no luminescence at ordinary temperatures after exposure, or which do so for only a very short time, become distinctly luminescent when warmed, some even after the lapse of days or weeks. This thermo-luminescence is thus analogous to the chemical storage of electrical energy in an accumulator cell. The capacity for giving out colored light continues until the cessation of the chemical action thus brought into play. The effect of great depression of temperature is also considered, some remarkable results having been attained by Dewar on subjecting various luminescent substances to the temperature of liquid air.

By proper selection of luminescent salts it is possible to produce a selected series of

tints during and after exposure to those spectrum rays which are most effective in photography; but such colors cannot be made fixed and permanent. The problem of securing on the photographic plate a faithful and lasting reproduction of the various hues of a spectrum thrown upon it has long baffled most of those who grappled with this subject. While not yet completely solved, it has been handled with much nearer approach to success during the last five years than during an equal number of decades previously. Two quite different methods are to be considered in tracing this success. The first, originally due to Becquerel, has been greatly improved by Lippmann in Paris. It depends upon the production of stationary waves of light. The theoretical possibility of producing these has long been apprehended, but demonstrated success was attained for the first time a few years ago by Otto Wiener, in Strassburg, a physicist whose admirable work in optics has received but little attention in America. The conditions requisite for success are here given, and Wiener's method is explained; as is also the application of his results to confirm the views of Fresnel, in opposition to those of Neumann and MacCullagh, in regard to the relation between plane of polarization and direction of vibration of polarized light, and in regard to change of phase in the reflection of light at the boundary between two media differing in density.

The theory of Lippmann's method of photographing in natural colors is now discussed, but the conclusion is expressed that the method cannot long remain practically important because, like the daguerreotypes of fifty years ago, these colored photographs are incapable of multiplication. Wiener has lately published an elaborate research upon this subject, in which he recognizes the necessity for the employment, not of interference colors, but rather of what he

calls body colors (Körperfarben) due to chemical modification of the reflecting surface. While it is abundantly possible that colored illumination upon suitable color-receptive materials can give rise to similar body colors, we are still far from having these materials under control. There seems at present to be greater promise in a second and quite different application of optical principles, that of taking three separate negatives simultaneously from the same object through color screens appropriately chosen in accordance with the Helmholtz theory of color. The positives from these, taken on suitably dyed plates, are then superposed; or light transmitted through the negatives is combined by an appropriate instrument, as in the method of F. E. Ives, which was explained. This solution of the problem gives very beautiful results, but the necessity for an auxiliary instrument interferes with its general availability. It does not seem probable therefore that photography in colors will soon interfere seriously with that photography in light and shade with which most of us have had to content ourselves thus far.

Investigations in the infra-red region of the spectrum were now considered, the foremost place being given to Langley's recent work, which will undoubtedly make it possible to determine in large measure to what extent the cold bands in the heat spectrum are due to atmospheric absorption, and which of them are produced by absorption outside of the earth's atmosphere. Notice was given to the work of Snow, Rubens, Angström, Paschen and Percival Lewis in their studies of the infra-red spectra of various chemical elements.

In regard to the visible spectrum, reference was made to Rowland's extensive work in the determination of wave-lengths for all the chemical elements; to the recent discovery of argon and helium; to the grouping of spectral lines by Kayser and

Runge; to Keeler's spectroscopic study of Saturn's rings, and Hale's use of the spectroheliograph.

In the domain of polarized light the work of Nichols and Snow, of Merritt, of Marston and of Crehore was duly noticed, including the application to gunnery.

Physiological optics is a subject too large to receive its proper share of attention in an address chiefly on physical optics. Mrs. Franklin's theory of light sensation was discussed, and a brief account was given of Mayer's ingenious experiments on simultaneous color contrast, which have been confirmed by the experiments of the author. Reference was then made to Ferry's law of retinal persistence, and its application to the explanation of the 'artificial spectrum top,' which has excited such general interest during the last year. That it should have been copyrighted is deemed a precedent that may yet result in an attempt to copyright the solar spectrum.

IN addition to the address of the Vice-President twenty-five papers were read in full and three by title, about the same number as last year at Brooklyn.

1. *Expansion of Jessop's Steel, Measured by Interferential Method* (30 m.), by E. W. MORLEY and WM. A. ROGERS. The Fizeau method with numerous adaptations and improvements was employed to determine the thermal expansion of Jessop steel, with the result that the measurement of the elongation is now much more accurate than the temperature observations. The latter appears to be correct to $\pm 0.1^\circ\text{C}$. and hence the coefficient of expansion is correct to 0.1%; which is about the accuracy at present attained by other methods. The authors expect to improve the thermometric part of the apparatus and attain an accuracy much greater than at present.

2. *Flow of Alternating Currents in an Electric Cable* (20 m.), by M. I. PUTIN. This

question has heretofore been treated only mathematically and without considering the end conditions, and hence no satisfactory conclusions have been reached. The author treats the current in a cable like a swinging string and similarly introduces the members representing the end conditions. The result of the analysis shows that the representative curves are produced by superimposing a sine curve upon a catenary. Experimental measurements upon an artificial cable, with rates of alternation between 650 and 3,000 verified the analytical conclusions very beautifully.

3. *The Most General Relation between Electric and Magnetic Force and their Displacements* (20 m.), by M. I. PUPIN. It was shown that the difference between Maxwell's ideas concerning electricity and those of his predecessors lies in the form and in the extension of his considerations to the medium. The author believes that by a suitable extension of the equations of condition of the ether the phenomena of light can be more simply explained by the electro-magnetic theory than by the elastic solid theory.

4. *Relations of the Weather Bureau to the Science and Industry of the Country* (15 m.), by WILLIS L. MOORE.

5. *Solar Magnetic Radiation and Weather Forecasts* (15 m.), by FRANK H. BIGELOW.

6. *Clouds and Their Nomenclature* (20 m.), by CLEVELAND ABBE.

7. *Cloud Photography* (10 m.), by ALFRED J. HENRY.

Numbers 4, 5, 6 and 7 were read before a joint session of Sections A, B, E and I, and will receive ample attention elsewhere.

8. *A New Apparatus for Studying Color Phenomena* (30 m.), by E. R. VON NARDROFF. This consists of a mechanism by which three beams of light are taken from the condenser of a projection lantern, and controlled as to intensity by diaphragms and as to color by various colored screens. These beams then fall upon a distant screen

and may be caused to appear distinct or overlapped and combined, and afford an excellent means for studying a large variety of color phenomena.

9. *Voice Production with Photographs of the Vocal Cords in Action* (15 m.), by F. S. MUCKEY and W. HALLOCK. It is ordinarily assumed that increase of tension is the only means provided for raising the pitch of the note sung. Dr. Muckey has found that with proper training the arytenoid cartilages may be rotated, thus shortening the effective length of the cord, and probably also lightening its weight by holding the thicker muscular part of the cord. The photographs verify the conclusions as to the rotation and shortening of the cords.

10. *Note on the Limits of Range of the Human Voice* (5 m.), by W. LE CONTE STEVENS. The author finds the singing limits to be from 43 to 2,048 vibrations per second, and has observed the squeal of a child as high as 3,072 per second.

11. *Voice Analysis with Photographic Record* (20 m.), by F. S. MUCKEY and W. HALLOCK. Resonators tuned to the pitch of bass C and its seven first overtones are provided with manometric capsules of improved form and adaptation. While this note (128 per sec.) is sung on different vowels and by different singers the flames are photographed as described in the 'Physical Review,' Vol. II., p. 305. In this way many negatives have been obtained illustrating the different *timbre* or *klangtint* of the vowels and voices. Many more must be taken before reliable conclusions can be drawn.

12. *The Reproduction of Colors by Photography* (60 m.), by F. E. IVES. By taking negatives through color screens, and then projecting the pictures through similar screens and superimposing upon the screen, effects are obtained which are very wonderful, though not entirely above criticism. A similar process has been applied to the stereoscope, giving better results.

13. *Color Definitions for the Standard Dictionary* (10 m.), by W. HALLOCK and R. GORDON. Disks painted with English vermilion, mineral orange, light chrome yellow, emerald green and artificial ultra-marine blue, in a *thick* solution of gum arabic, have had their wave-length determined. These combined with white, and a disk covered with lamp black and shellac, enable one to place such combinations upon a rotation machine as to match any color in nature or art. This process was applied to the study of 6,000 samples of colored objects resulting in formulæ for some 500 named colors.

14. *On Standard Colors* (20 m.), by J. H. PILLSBURY. The author urges correct and scientific teaching of color especially in early youth, approving the use of Maxwell disks, printed red, orange, yellow, blue and violet, by lithography, with black and white.

15. *Significance of Color Terms* (15 m.), by J. H. PILLSBURY. The uncertainty attached to color nomenclature was pointed out and the desire expressed that it should be removed by the introduction of a method of definition similar to that explained in the previous paper (No. 14). Numerous illustrations were given showing varieties of colors, including some well-known flowers.

16. *On the Comparison in Brightness of Differently Colored Lights and the 'Flicker Photometer'* (20 m.), by FRANK P. WHITMAN. A very interesting and successful comparison test of the Rood flicker photometer, an ingenious device of rotating semi-disc, allowed the easy and accurate comparison of lights, etc., upon an ordinary photometer bench. The tests upon the colors of the spectrum brought out the accepted maximum of luminosity in the yellow, and also showed a slight increase in luminosity at the extreme violet. It must, however, be said that these measurements were made upon colored papers and not upon the spectrum itself.

17. *Observation on the Relations of Certain*

Properties of Line Spectra to the Physical Conditions under which they are Produced (20 m.), by J. F. MOHLER and W. J. HUMPHRIES. Experimenting upon the spectra of metals under pressures of air up to 15 or 20 atmospheres, certain widenings and displacements of the lines were noted, and an increasing similarity in appearance to the solar spectrum.

18. *An Experimental Investigation of the Rotary Field* (20 m.), by H. S. CARHART. An iron ring wound with a continuous coil tapped at four, six, or more points combined with an ingenious commutator furnished a rotary field that could be stopped and studied at any instant. The photographs of iron filings in the field, show a 'measuring worm motion' of the poles, with no essential difference between the two and three phase connection.

19. *Electrolytic Reproduction of Resonators* (5 m.), by W. HALLOCK. A wax ball is turned the size and shape of the spherical resonator, and then copper plated. After melting out the wax, the resonator is tuned by cutting off the lip of the mouth.

20. *A Photographic Method of Comparing the Pitch of Tuning Forks* (5 m.), by W. HALLOCK. Each fork is clamped before a manometric capsule, bowed, and the flames photographed, and the relative number of vibrations counted.

21. *Illustration of Gems, Seals, etc.* (5 m.), by W. HALLOCK. An impression of the gem is taken in the transparent wax, used first by O. N. Rood, and this is photographed by transmitted light in an enlarging camera.

22. *An Examination of the Statement of Maxwell that all Heat is of the Same Kind* (15 m.), by WM. A. ROGERS. The author argues, from his observations with his inter-ferential comparator, that heat of radiation is different from heat of air contact and should be measured in a different unit.

23. *Phenomena of Electric Waves Analogous to those of Light with a Diffraction Grating*

(20 m.), by C. D. CHILD. A Righi vibrator and a tinfoil receiver were used to study the diffraction of electric waves by a tinfoil grating. The apparatus worked quite well and the resulting wave-length determinations were satisfactory.

24. *The Effect of Age upon the Molecular Structure of Bronze, Glass and Steel* (10 m.), by WM. A. ROGERS. As a result of comparisons extending over a period of five years, the author concludes that our fear as to the molecular changes of length of our standards is not well founded.

25. *A New Determination of the Relative Length of the Yard and Metre* (8 m.), by WILLIAM A. ROGERS. A new determination gives the metre as equal to 39.37015 inches, slightly different from the accepted international value, 39.3700, which, however, is being reviewed by the Bureau which may confirm the author's value.

The following papers were read by title:

26. *California Electric Storms* (20 m.), by JOHN D. PARKER.

27. *A New Formulation of the Second Law of Thermodynamics*, by L. A. BAUER.

28. *The Method of Reciprocal Points in the Graphical Treatment of Alternating Currents*, by FREDERICK BEDELL.

It will be seen that the papers were of unusual interest, and they provoked much careful discussion. The attendance was large, ranging from 40 to 60, and the number of specialists present was remarkable.

A motion by William Orr, Jr., of Springfield, resulted in the appointment by the Council of the following committee to consider standard colors and color nomenclature; O. N. Rood, chairman; W. Le Conte Stevens and W. Hallock. Similarly a motion by H. S. Carhart, of Ann Arbor, resulted in the appointment of a committee upon electrical and other standards, consisting of T. C. Mendenhall, chairman; William A. Rogers, H. A. Rowland, H. S.

Carhart, E. L. Nichols and R. S. Woodward, with power to add a seventh.

WILLIAM HALLOCK.

SECTION C. CHEMISTRY.*

THE address of the Vice-President of the Section, Dr. William McMurtrie, of Brooklyn, has been already printed in SCIENCE, September 6th. Owing largely to the efforts of the Vice-President and of others under his direction in preparing for the meeting, the attendance at the sessions of the Section was large and the papers presented were of more than usual interest.

FRIDAY MORNING, AUGUST 30.

The first paper was by Professor W. P. Mason, of Troy, N. Y., 8 on 'Foreign Laboratory Notes.' He spoke of recent experiments in Paris showing the effect of the liver in stopping poisons in the organism; also that it has been shown that urea is not toxic in action. Diagrams were distributed showing the way in which the number of deaths of children corresponds to the percentage of samples of bad milk found by the public analysts.

New methods used in Paris for the examination of potable waters were spoken of and Miquel's theory of the auto-contamination of waters was referred to.

Mrs. Ellen H. Richards and J. W. Ellms, of the Massachusetts Institute of Technology, read a paper on 'The Coloring Matter of Natural Waters, its Source, Composition and Quantitative Measurement.' The colors appear to be formed by the partial carbonization of organic matter. A series of natural waters furnishes the best secondary standard. Such standards fade and must be replaced at least once in six months. The tintometer is very satisfactory for making the comparison. The colors obtained

* Reported by W. A. Noyes, A. H. Gill and Francis C. Phillips.

by treating steel with nitric acid appear to furnish the best primary standards.

Professor W. D. Bancroft, of Newport, R. I., spoke on 'Saturated Solutions and the Mass Law.' The author showed that the precipitation of salts from saturated aqueous solutions by organic liquids and by other salts can be expressed by the formulae

$$(X+A)^n y = c$$

and $(X+A)^n (y+B) = c$, in which X is the quantity of the salt in the saturated solution and y the quantity of the added liquid or salt. A and B are calculated from the experiments themselves and the formula may be derived by an application of the law of mass action.

Professor F. P. Venable, of Chapel Hill, N. C., discussed 'Recent Views on the Periodic System,' giving a very brief historical review and referring more in detail to the views of Preyer, Thomsen and Boisbaudran.

Thomsen's table is the same as that of Carnelley, the latter having stated that it was originally Bayley's. Professor Venable has given a table himself in the Journal of the American Chemical Society, but disclaims any attempt to discuss the genesis of the elements. The law is incomplete, but establishes that the elements are not independent bodies but are closely related to each other. He also described a synoptical table of the elements by Professor L. R. Gibbs, of Charleston, S. C., published in 1875, which contained many of the features of Mendeleef's system, though developed without knowledge of that. It also anticipated much of the later work.

FRIDAY AFTERNOON.

Dr. H. N. Stokes, of Washington, gave an account of the work which has been done with argon and helium.

Prof. E. W. Morley, of Cleveland, Ohio, gave an account of his determinations of the volumetric composition of water. The

ratio obtained by Professor Morley some years ago, while undoubtedly the same which any other observer working with apparatus of the same nature and dimensions and with the same care, would obtain, was incorrect because of some physical reason, dependent on the measurement of gases in tubes, but not clearly understood. By a different method, the ratio has been determined with very great accuracy as being 2.00269. This value agrees closely with that obtained by Scott in his later work, and also fairly well with the result calculated by the formula of Van der Waals. The densities of hydrogen and of oxygen have also been determined by methods which eliminate the effect of mercurial vapor. The values are, for a latitude of 45°, 0.089873 for hydrogen and 1.42900 for oxygen.

Prof. C. H. Herty, of Athens, Ga., spoke of 'Double Salts and Allied Compounds.' Attention was called to the inaccuracy of past work, the various lines of investigation followed, and the theoretical views of the constitution of these bodies which have been advanced by Horstmann, Remsen, Werner, Carnegie and others. None of these seem to be entirely satisfactory. Lines of work were suggested which may prove useful in determining the constitution of these bodies.

Prof. W. A. Noyes, of Terre Haute, Ind., read a paper on 'Camphoric Acid.' A new and independent proof that cis-campholytic acid is a *D'* compound has been obtained. A study of hexahydro-xylylic and some of its derivatives has given quite conclusive proof that the Armstrong-Wallach formula for camphoric acid is incorrect.

FRIDAY EVENING.

Prof. P. C. Freer, of Ann Arbor, described his recent work on 'Tetrinic Acid.' This indicates that the correct formula for the acid is

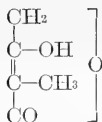

Prof. A. B. Prescott, of Ann Arbor, gave an account of work on periodides. A classification and theoretical discussion of the character of periodides was given and was followed by a description of the following periodides:

A. Pyridine Alkyl periodide.

1. Pyridine methyl pentaoidide.
2. " " dioidide.
3. " " trioidide.
4. " " tetraoidide.
5. " " octoidide.
6. " ethyl trioidide.

B. Periodides of the amine and of the tertiary ammonium base.

1. Pyridine tetraoidide.
2. " hydrogen pentaoidide (Dart-fert).

C. Dipyridine trimethylene dibromide.

Whenever a mixture of alkyl iodide and iodine is added to pyridine, there will be some formation of the periodide of the amine base as well as of the pyridine alkyl periodide. Mr. R. F. Flintermann and Mr. B. F. Trowbridge have done most of the experimental work described.

MONDAY MORNING, SEPTEMBER 2.

Prof. C. L. Jackson, of Cambridge, read a paper on 'Some New Color Reactions.' On adding sodium ethylate to brom-di-nitrotoluene and other similar bodies, unstable compounds having brilliant colors were formed. V. Meyer has made similar observations and the work will not be continued, but results obtained indicate that the nitro group is directly affected in the formation of these bodies.

Prof. Jackson read a second paper on 'Picryl Malonic Ester.' Two forms melting

at 58° and at 64° have been obtained. The former was obtained at first, but repeated attempts to prepare it a second time were unsuccessful.

A discussion on 'The Teaching of Organic Preparations' followed. Prof. P. C. Freer, of Ann Arbor, introduced the subject. He advocated the selection of some classical research which is to be carefully studied and the experimental work repeated by the student. The discussion was continued by C. L. Jackson, T. H. Norton, W. A. Noyes, A. B. Prescott, W. H. Seaman and L. W. Andrews.

Prof. A. B. Prescott gave an introduction to the subject, 'Inherent Limitations in the Accuracy of Analytical Work.' An abstract of a paper by A. A. Blair and J. E. Whitfield on 'Ammonium Phosphomolybdate,' and the reducing action of zinc in the reductor, was given. Prof. E. D. Campbell gave a provisional schedule of admissible limits of accuracy in certain metallurgical analyses. An abstract of a paper by F. P. Dewey on 'Accuracy in Metallurgical Analysis' was given by Prof. Prescott. In these papers an attempt was made to make a beginning toward the establishment of standards of accuracy which may be demanded of chemists in various forms of analytical work. The papers were discussed by W. O. Atwater, L. F. Kebler, J. L. Howe, William McMurtrie and others.

Prof. T. H. Norton, of Cincinnati, illustrated the use of thioacetic acid as a laboratory reagent. Methods of preparation were also discussed; in the discussion the odor of the thioacetic acid was unfavorably noticed.

MONDAY AFTERNOON, SEPTEMBER 2.

Prof. T. H. Norton spoke of the phosphorus contained in phospho-cereal. Of about five per cent. of P₂O₅ present, about one-half passes into solution on boiling with water for two hours.

Prof. R. B. Warder, of Washington, read

a paper on the Major Premise in Physical Chemistry. The tendency of chemical progress is to place more emphasis on physical methods and the mathematical deductions of thermodynamics. The aid of physicists and mathematicians would be desirable in obtaining rational instead of empirical formulas.

Prof. C. L. Jackson, of Cambridge, gave an interesting account of the order which he follows in instruction in general chemistry.

Prof. T. H. Norton spoke of laboratory construction and equipment.

Prof. J. L. Howe, of Lexington, Va., spoke of the relative order of theory and description in the teaching in general chemistry. For college students a course of instruction in which theoretical considerations appear early and are used constantly in the development of the work was advocated. The paper was discussed by P. C. Freer, T. H. Norton and C. H. Herty.

A paper by H. W. Wiley, of Washington, on quantitative experiments in general chemistry was read.

A paper by Prof. G. C. Caldwell, of Ithaca, on instruction in quantitative analysis, was also read.

TUESDAY MORNING, SEPTEMBER 3.

Prof. Norton read a paper by Dr. H. C. Bolton, of New York, on 'Bibliography as a Feature of the Chemical Curriculum.' The author urged that more bibliographic work should be done in our colleges and universities. Prof. W. A. Noyes spoke of the preparation of papers on special topics by students and of journal reviews. The topic was discussed by H. P. Talbot and W. O. Atwater. A paper by P. T. Austen on 'Chemistry as a Liberal Education' was omitted, in the absence of the author, for lack of time. Dr. E. E. Smith, of New York, read a paper on 'A Specific Form of Cell Metabolism.' The paper described the

composition of the cell and relation of chemical composition to the structural elements. Reference was then made to the decomposition products of the nucleins and the relation of these to uric acid brought out. It was then explained why uric acid excretion, when the ratio to the amount of urea is considered, becomes an index to the existence of nutritional disturbances, particularly of a class whose symptoms are largely subjective. A paper by E. A. de Schweinitz upon 'Products of Pathogenic Bacteria' was read by title, as Dr. de Schweinitz was unable to be present.

The paper of Prof. W. O. Atwater, upon 'Some Points connected with the Chemistry and Physics of Metabolism,' was not read, but was summarized by him as follows: The physiologist must either become a chemist or turn over the products of his work to a chemist for examination. Experimentation must be based upon income and outgo of matter in the body in terms of energy. This has only been done recently, as the apparatus has been wanting.

A new field for the chemist is thus opened up which is fully as important as any other. The value of the basal calorimeter for the determination of the heating value of foods was spoken of. Discussion was participated in by Prof. A. B. Prescott.

'Record of Progress in Agricultural Chemistry,' by H. W. Wiley, was read by title by Prof. Atwater.

The author dwelled upon the recent advances in agricultural science and the increased facilities which have been provided for its study at the larger colleges and universities.

One of the chief difficulties encountered by agricultural chemists has been found in the selection of accurate methods for the analysis of the constituents of plants, and certain classes of these constituents are as yet little understood. Great progress is being made, however, in their investigation.

Recent investigations have clearly shown that atmospheric nitrogen plays an important part in the nutrition of plants. The assimilation of nitrogen from the atmosphere can only result from the activity of a microbe which is present in the soil. Fertility of the soil is, in case of certain plants, largely dependent upon the existence of this bacterium. It is probable that a study of the part played by the bacteria in the soil will prove of great importance. The results already obtained in introducing bacteria into the soil have been most encouraging in the case of certain plants.

The paper was discussed by Profs. G. E. Patrick, J. L. Howe and W. O. Atwater. Prof. Atwater described the experiments which are being conducted in this country and abroad to determine comparative values of foods and the quantities of food required by people of different classes and occupations.

A paper by Prof. Milton Whitney, on 'Recent Progress in the Analysis of Soils,' was omitted owing to the absence of the author. Mr. J. T. Morehead read a paper on 'Calcium Carbide.' The author described the process of manufacture in an electric furnace. The furnace is constructed of ordinary brick and is covered. Vertically supported carbon rods, 4 inches thick, constitute the positive electrode. A plate of iron at the bottom of the furnace, covered by a layer of carbon, forms the negative electrode. The charge consists of a mixture of ground lime and coke.

A current of 100 volts and 1700 amperes produces 80 pounds per hour of calcium carbide. The product is a hard crystalline substance having the composition Ca C_2 . Immersed in water it is decomposed with violence but with very little heat, and yielding slacked lime almost white in color. Five cubic feet of acetylene gas are produced by one pound of carbide. Large quantities of the carbide are now being

manufactured by the Wilson Aluminum Company in their works situated at Spray, N. C. After a tribute of thanks to Dr. Wm. McMurtrie, Vice-President of the Section of Chemistry, the Section adjourned.

SECTION D. MECHANICAL SCIENCE AND ENGINEERING.

THE chairman of Section D, William Kent, of Passaic, N. J., and the secretary, Professor Henry S. Jacoby, of Ithaca, N. Y., were both present throughout the meeting of the Association. The Vice-President's address, which is published on page 321 of SCIENCE, was delivered on Thursday afternoon, August 29th, and excited more than usual interest outside as well as in the Section by its able exposition of the work of the engineer as related to economic progress.

The papers were read on Friday. That of H. N. Ogden, of Ithaca, N. Y., treated of the 'Economics of Engineering Public Works.' After an introduction referring to the extravagance of the American people, and to the influences which favored individual action and rendered unnecessary the combination of interests by coöperation until recently, instances were given of corporations seeking advantage at the expense of the public good. The tearing-up of city streets, and digging one trench for gas pipes, another for water pipes, and others for sewers and steam pipes, without any mutual arrangement, was given as an illustration of the most common lack of economy in municipal affairs, as the people ultimately pay for all the trenches and suffer the loss incident to breaking up the streets so frequently, interfering with traffic and often ruining the paving. Similar extravagance is seen in the conduct of elections and the assessment and collection of taxes. Numerous instances of the ability of our people to adapt means to ends, to devise new methods to changed conditions, give hope

for the future. The Interstate Commerce Law, railroad commissions, the appreciation of the value of city franchises and the utilization of garbage wastes are evidences of progress in public economy. The importance of deciding by a competent authority the relation of our streams to pure water supply and to carrying off sewage was urged as one of many problems demanding more careful attention.

In the discussion which followed, E. L. Cortell, in alluding to the author's statements concerning competition, considered it unwise for any government to decide what division shall be made between transportation by rail and by water. In France it was found necessary to keep up the rates on the railroads in order to save the existence of the canals. Multiplying the means of transportation tends to lower the rates. The Interstate Commerce Commission can prevent the throwing away of money in the unnecessary construction of new railroads.

Professor O. H. Landreth spoke of the immense investment made for the water supply of Boston and of 25 or 30 towns by coöperation, and Vice-President Kent called attention to the corner in the water supply in northern New Jersey secured by large corporations.

In a paper on the 'Mathematical Theory of the Windmill,' by Professor DeVolson Wood, of Stevens Institute of Technology, a formula was derived for the pneumatic energy of the wind upon a sail, and the results were compared with those given in Wolf's Treatise on Windmills.

Professor Mansfield Merriman, of Lehigh University, presented a valuable paper on 'Partially Continuous Drawbridge Trusses, with a Method of Deducing Formulas for the Reactions.' The first case of partial continuity considered was the rim-bearing drawbridge without webbing in the panel over the support. The second was that of the double rolling draw, where the webbing

is continuous but not the chords, and the third case was that of the double swing-bridge, which is a combination of the first two. In all these cases the value of the reactions deduced were found to be intermediate between those for simple and for continuous trusses.

A paper by Professor J. J. Flather, of Purdue University, gave the results of some 'Experiments on the Flow of Steam and a Comparison with those obtained by Napier's Formula.' The difference was very small and some of the conditions under which the experiments were made were such as to require additional experiments to be made.

Professor H. S. Jacoby, of Cornell University, read a paper on the 'Design of Fish-Plate Timber Joints,' in which formulas were given for the resultant pressure of the side of round bolts or pins against the timber both in the direction of the fiber and perpendicular to that. For yellow pine with compressive stresses of 1100 and 300 pounds per square inch on the ends and on the sides of the fiber respectively, the former resultant was 0.627 times the product of the diametral projection of the surface of the bolt by the compressive stress on the ends of the fibers, while that of the latter was 0.4 times the same product. The force tending to split the timber when the resultant pressure is in the direction of the fibers is one-half of this last amount. The corresponding value of the resultant in the direction of the fibers obtained by experiment was found to have an average constant of 0.60 instead of the theoretic value of 0.627. The radial angle with the fibers at which the fibers begin to crush sidewise was also determined theoretically and by experiment and the agreement was very close. For the above timber the angle was $15^{\circ} 37'$ to $17^{\circ} 00'$ in the experiments, the theoretic value being $15^{\circ} 50'$. The tendency to split the timber must be provided for either by transverse bolts or by

increasing the longitudinal shearing surface which would otherwise be required.

The officers of the Section elected for the next year by the Association are Professor F. O. Marvin, of the University of Kansas, for Chairman, and Professor J. Galbraith, of the School of Practical Science, of Toronto, Canada, for Secretary.

*DEVELOPMENT OF VEGETABLE
PHYSIOLOGY.**

THERE is a certain fitness in bringing before the section of this Association, which has been most recently established, some account of that department of botanical science which is one of the latest to be brought into notice as a grand division of the subject. For vegetable physiology, the topic which is to engage our attention, is like a western or African domain, long inhabited at the more accessible points, more or less explored over the larger portion, but with undefined boundaries in some directions, and with rich and important regions for some time known to the explorer, but only now coming to the attention of the general public. In fact, our domain of vegetable physiology is found to be a diversified one, in some parts by the application of chemical and physical methods yielding rich gold and gems, in other parts coming nearer to every man's daily interests with its fruits and grains. Thus it comes about that, before the public is well acquainted with the name of the science, it has differentiated itself into two or three sciences having quite separate objects in view.

It is the purpose of this address to acquaint you with the growth and present outlines of the group of sciences which for convenience are included under the heading of vegetable physiology, and also to show why they deserve recognition as important

*Address of the Vice-President, Section-G., American Association for the Advancement of Science at the Springfield Meeting, August 29, 1895.

constituents of a liberal education along with other natural sciences. The point of view at all times will be that of the American botanist.

In the development of botany in America the science has passed through successive waves or stages of popularity, constantly increasing in momentum, widening its scope by evolution of new interests, and more and more exhibiting virility by its adaptability to the needs of the times. That botany has in it something that may be transmuted into money has only recently been discovered, but it is a discovery that is likely to work benefit not only to the practical man who makes application of scientific truths to commercial ends, but also reciprocally to the investigator who thinks only of uncovering a new fact or establishing a new law. To adequately meet the requirements of modern botany in the way of laboratories, gardens, herbaria, libraries and apparatus requires a capital that not long since would have been deemed fabulous. The money to meet this demand of a growing science must be expected to come in the main as the voluntary contribution of an interested public—the reciprocal response to the attitude of botany toward the general welfare.

I have mentioned the economic aspect of botany thus early, because it is one of the significant changes which has come over the science within the last decade or two, and to which vegetable physiology in some of its features is, I venture to say, about to add further important contributions. Science no longer shrinks into the shadow of the closet for fear of being implored to lend a hand at securing revenue, but steps forth and curiously scrutinizes every process of the practical world, often finding there its most fruitful fields for fundamental research.

The problems of vegetable physiology possess to a greater or less degree a special

element of interest not inherent in those of other departments of botanical science. They embrace the dynamical property of motion, which never fails to exercise a fascination over the human mind. Physiology, in fact, deals with what plants do, their methods of activity, their behavior; while the other divisions of botany treat of what plants are, or have been, their form, structure, and relation of parts. The one is the study of the organic machine in action, and the other the contemplation of its component members.

Movement in plants does not attain the rapidity exhibited by animals. Some movements in both cases are ultra-visual, as the translocation of molecules in metabolism, the diffusion of gases, and in plants especially the flow of liquids. In plants even the movements of the organs are comparatively slow. While the leaves of the sensitive plant telegraph plant, and Venus's fly-trap and the petals of certain orchids excite the wonder of the casual beholder, most plant organs move too slowly to be readily detected without mechanical magnification. This does not prove a detraction to the interest of the subject, however, as it has led to the invention of ingenious and complicated machines, whose numerous wheels and bands inspire a sense of importance, particularly appealing to a large class of persons in this age of machinery, and constituting an element in securing favorable attention from the public, while it adds a charm to the work of the investigator, rivalling that of the microscope. It is yet but the dawning of day for the display of mechanical contrivances as aids to botanical research, and the future gives promise of notable achievements. The names of Barnes, Anderson, Stevens, Stone, Golden, Thomas, Frost and Arthur at present are representative of the American inventive spirit in botany. The most perfect and interesting pieces of apparatus yet

turned out by them embrace Frost's and Golden's auxanometers for recording the increase in length or thickness of growing organs, Thomas's apparatus for recording the variation in pressure of sap resulting from root action, Anderson's automatic balance for registering the rate and amount of change in the weight of an object used in studying transpiration and growth, and Arthur's clinostat for neutralizing the action of gravity and light, and his centrifugal apparatus for substituting mechanical force for that of gravity.

While having in mind the public interest in our science, it may be well to notice the very small basis of information on which this interest is founded. Only the vaguest notions are current regarding the nutrition of plants, the uses of the leaves, the movements of sap, the purposes of color, and the means by which new positions are assumed. This ignorance is primarily due, of course, to the some cause which has so long delayed the development of the science upon the technical side—the fact that almost nothing can be learned of the functions of plants from direct observation. In regard to the physiology of animals, even the lowest, much may be inferred by observing their behavior and analyzing the phenomena from the human standpoint, but there are no obvious similarities between plants and the higher animals, and it is necessary to resort to careful experimentation and profound study to arrive at a fair understanding of the vital actions of plants. Physiology is an experimental science, and the public must perforce derive its knowledge second hand without much opportunity of verification. It must be admitted that, although a view of this portion of the *res publica natura* has its fascination, yet the attainment of vantage ground for the survey is necessarily difficult and slow.

The term public, when used in connection with vegetable physiology, needs to be con-

structed liberally. It will include, without doubt, some able scientists and men of liberal education. I may be permitted to cite an occurrence to which some in this audience were witnesses. Some time since the subject of gases in plants was before the Association and induced an animated discussion. Probably half of those participating confounded respiration, which is a general function of all plants, as well as animals, under all conditions of existence, with the photosynthetic function of fixation of carbon by the green parts of plants in the presence of sunlight. Both processes have to do with oxygen and carbon dioxide, but the resemblance goes no further. It is an error dating back to the last century, when the two processes were discovered, and one for which botanists themselves are by no means without responsibility. Another error not yet dislodged from the cobwebby corners of many a well-read man's intellectual storehouse is the old fiction of a circulation of sap, so dear to those who desire to find analogies in plants with physiological processes of animals. It is not much over fifty years since the learned French Academy exhibited its ignorance of vegetable physiology by awarding the grand prize to an essay founded upon this error; and the error still lives.

But the general ignorance of even the best established and most readily apprehended facts of physiology may be justly extenuated when the pedagogical status of the subject is examined. Botany, as a substantial part of the curriculum, cannot be said to have received recognized standing in the American educational system until the time of Asa Gray. In the latter part of the decade of the thirties his first textbook, the 'Elements of Botany,' appeared, and in the decade following, the 'Text-book for Colleges' and the 'Manual,' all of which works showed a true appreciation of the best features of the science and the needs

of the time. They were so well conceived, and so much in demand, that new editions rapidly succeeded one another; and to the present day they hold a high place in the estimation of botanical teachers. These works possessed a specially potent element of virility in being the expression of knowledge at first hand, the words of the master. In so far as inspiration was drawn from foreign sources it came chiefly from French and English scholars, of whom De Candolle the eldest and Robert Brown were the representatives.

A half century ago vegetable physiology, in the fulness of the modern meaning of the words, did not exist. Structural botany was then the dominant phase, and in elementary instruction took the shape of close attention to the form and arrangement of the organs of flowering plants, with the ulterior object of being able readily to determine the names of the plants of the field. Even then physiology presented some attractive features, but they appeared largely extra-territorial, as the title of the book from which most of us received our early botanical pabulum testifies: 'First Lessons in Botany and Vegetable Physiology,' by Asa Gray, issued in 1857, and continuing its supremacy as a text-book until 1887, when it was revised and renamed.

In the seventies botanical laboratories began to form a necessary feature of the best institutions, each with its quota of compound microscopes and reagents, in which we followed the example of Germany, such laboratories having been established at Halle, Breslau, Munich and Jena a decade previous, and subsequently at many other centers of learning. With the advent of Sachs's 'Textbook of Botany' in English dress about this time, the science in America took on a new and vigorous phase of development. The method of this work found more convenient expression in Bessey's 'Botany' (1880), which for a decade was

the recognized standard of instruction. A wealth of laboratory guides soon appeared, and American botanists became devotees of microscopic anatomy. I scarcely need call your attention to the triumphal advancement of botany during the decade of the eighties; it is so fresh in every one's mind. It amounted to a revolution; the work of the herbarium was well-nigh abandoned for the study of the cell. Those of the older systematic botanists who took no part in this upheaval became alarmed, and put forth vigorous protests, claiming with much justice that pupils so trained lost breadth of view and proper perspective. An editorial writer in the *Botanical Gazette* very clearly contrasted the two methods of instruction. "The ancient method," said he, "gives a wide range of acquaintance with external forms; a general knowledge of the plant kingdom and its affinities, a living interest in the surrounding flora; but it disregards the underlying morphology of minute structures and chemical processes, the great principles which bring plant life into one organic whole. The modern method, on the contrary," he continues, "takes a few types, carefully examines their minutest structures and life work, and grounds well in general biological principles; but it loses the relation of things, as well as any knowledge of the display of the plant kingdom in its endless diversity, and, worse than all for the naturalist, cultivates no love for a flora at hand and inviting attention. The former is the method of the field, the latter of the laboratory."

But under both ancient and modern methods of instruction, whether the teacher were a systematist or a histologist, whether the pupil pulled apart flowers under a hand lens or dissected tissues under a compound microscope, botany flourished in America. There was, in reality, a better philosophy abroad than usually appeared in practice. The layman, remembering his school days,

might assert with Julian Hawthorne that "botany is a sequel of murder and a chronicle of the dead," but the professional botanist, imbued with the spirit of the times, resented the imputation as no fault of the science; and while deploring the well enough known mediævalism and incompetence of teachers, who only disclosed a descriptive and classificatory science, with marvelous wealth of terminology to be sure, but as lifeless and unbiological as mathematics or astronomy, pointed to the motto held by all the progressionists, 'the study of plants as living things.'

The revivifying spirit which was pervading the botanical world, which strove to find in plants more than objects for the glossologist and the cataloguer, which interrogated the plant upon matters of action as if a dumb intelligence, which diffused a new light and a higher significance into every fact of the science, had its source in that all-pervading influence which emanated from the observations and interpretations of Charles Darwin. The brilliant series of works upon the behavior and relationship of plants by this author, beginning with the fertilization of orchids in 1862 and extending through a score of years, left a profound impress upon botanical thought, based as they were upon the connecting thread of evolution. So different now was the point of view that there sprang up what was called the 'new botany.' Although the inspiration of the 'new botany' was general, yet it manifested itself pedagogically chiefly in elementary instruction and in special studies. We may pass the delightful brochure of Asa Gray on 'How Plants Behave' (1872) with a bare mention, as it appeared too early to show any peculiarities of method not familiar to the readers of Darwin, and to call to mind the much less pretentious presentation of the new way as understood by Beal under the title of 'The New Botany' (1881). He

declares it to be a study of 'objects before books,' in which "the pupil is directed and set to thinking, investigating and experimenting for himself." The new method did not fit equally well into all departments of botany, and found its best expression for the most part in developmental and physiological subjects. It was in fact the chief agent in preparing the ground for the crop of physiology that is now being sown, and sown in a field selected and staked out by Darwin and Sachs.

Having shown how the field for the reception of the latest botanical husbandry was prepared, I may now briefly trace the source of the ideas with which it was implanted, and in doing so it is necessary to point out that vegetable physiology, as the term is generally employed, is not a homogeneous science.

The advancement of any subject is promoted by a clear understanding of its outlines, and it is in the interest of clear concepts and convenient usage that certain natural limitations should be respected by physiologists. Not that intergradation and mutual dependence do not occur, but that certain natural boundaries may be more or less distinctly recognized which will throw the subject-matter into sections and simplify the presentation of the numerous facts of the science.

The most obvious distinction to be made in the physiological aspect of organisms is in regard to their maturity. The organism in its embryonic or juvenile condition manifests functional peculiarities of the highest import, quite unlike those of the adult. The physiology of reproduction belongs here, and includes not only a study of the formation and increase of the young plant, that is, embryology, but genesiology as well, that is, the philosophy of the transmission of qualities and powers from the parent to the offspring, both in vegetative and sexual reproduction. It is a curious fact, which

Vines has recently called attention to, that even vegetative reproduction, as in the case of the growth of a plant from a cutting, brings about rejuvenescence of the protoplasm, the new individual showing the characters of youth, and not of maturity. In both sexual and asexual reproduction the attention should be focused chiefly upon the behavior of the cell, and a wonderful complexity will be found in these minute structures. The mystery of a world is bound up in this bit of protoplasm, and corresponding to the *multum in parvo* aggregation of properties there seems to be an unsolved intricacy of structure. To the study of what was originally supposed to be essentially homogeneous protoplasm, we have gradually distributed and extended the properties of the cell to the cytoplasm, the plastids, the nucleus, the nucleoli, the fibrillar network, the chromosomes, the centrosomes, the kinoplasmic spindle and the polar bodies. What further distribution of function will eventually be found, it is too early in the history of investigation to prognosticate.

But it is not every dividing cell that points the way to a new individual. Plants with complex structures possess tissues of embryonic character, such as the cambium, whose utmost power of division only leads to the production of additional tissues like those adjoining it, but are wholly incapable of originating a new individual, or even a new organ. From this histogenic extreme all gradations and variations occur, to the perfectly reproductive spore, which by its growth forms another individual without contributing anything to the support of the parent organism.

Beside the elementary riddles of life bound up in the processes of cellular reproduction, or cytogenesis, there are others, relating to nutrition, growth and irritability, which comprise what animal physiologists group under the term 'cellular physiology.'

for which Professor Verworn, of Jena, made such an impassioned plea in the *Monist* about a year ago. "We find," said he, "that even the minutest cell exhibits all the elementary phenomena of life, that it breathes and takes nourishment, that it grows and propagates itself, that it moves and reacts against stimuli," and he urged that therefore far more attention should be given to this department of physiology, as the key to many complicated processes. The physiological study of the cell, including both its reproductive and vegetative aspects, in so far as they may be considered the nascent functions of the elementary parts of the organism, may be conveniently considered under a single heading, 'caliology.'

Passing to the physiology of the adult organism, a little reflection will show that the activities of the plant may be considered from two standpoints: that of the plant's individual economy, and that of the plant's social economy, or its relation to other plants and animals and the world at large. Looking at the latter phase more closely, we shall find that the subject contains some of the most interesting topics in the range of botany, which appeal especially to the lover of nature, without losing their value as problems of the deepest scientific import. Among the relations of plants to the world at large may be mentioned the influence of climate, the means of protection against rain, drouth and cold, adaptation to the medium in which the plant grows and the establishment of rhythmical periods. Among the relations of plants to animals are those interesting chapters in the pollination of flowers by insects, the contrivances by which plants with a predilection for highly nitrogenous food may capture and feed upon insects, and the means adopted by plants to prevent injury from large animals, which are more or less familiar to the general public through the writings of Charles

Darwin. Among the relations of plants to one another comes foremost the struggle for existence, bringing into play the laws of natural selection and the survival of the fittest, together with much else that is now known under the head of evolution, followed by various phases of parasitism, mutualism and other topics. Is it not evident from this hasty and by no means complete outline that here is a portion of physiology which appeals to all classes of thoughtful persons, rich in possibilities for the philosophical and speculative mind, and bristling with queries demanding experimental solution?

Although this department of physiology has received much attention here and there for a long time, and some of its topics are well understood, yet only very recently has it fallen into place as a systematic part of the general subject, and no separate presentation of it has yet appeared in English, and only two works in German. There is some confusion regarding the name of the science. The Germans call it 'biology,' which may serve to emphasize the importance of regarding the plant as a living, plastic being, but is not an exclusory term, and also does violence to its philological derivation. Even the recently proposed modification into phytobiology does not much improve the term. The English usage of the word biology, as so admirably set forth by Huxley, and more or less consistently adopted in this country, leaves no place to introduce the imperfect usage of the Germans. Two years ago, in his wholly delightful 'Chapters in Modern Botany,' Patrick Geddes proposed the term 'bionomics.' The same year, however, a better term was advocated almost simultaneously in England and America. The Madison Botanical Congress indorsed the word 'ecology' as the designation of this part of physiology; and only a few days later Professor Burdon-Sanderson, in his Presidential address before the biological section of the

British Association, outlined the science and traced the origin of the name ecology, of which he made use.

Ecology, therefore, is the name under which we are to attempt the orderly arrangement of the facts, observations and deductions composing the science in which, to quote Burdon-Sanderson, "those qualities of mind which especially distinguish the naturalist find their highest exercise." The first independent treatise on the subject is by Wiesner (Vienna, 1889), and is an excellent model, while Ludwig's work, issued a few months since (Stuttgart, 1895), which is the second and to the present time only similar work, cannot be so highly praised. A work in English is greatly to be desired.

Having disposed of the external or sociological economy of the adult plant under the heading of ecology, we turn to the consideration of the internal or individual economy. This is the portion of physiology now in the ascendency, and the part which is usually more particularly intended under the present usage of the term vegetable physiology. The tendency is to restrict the titular use of the term to this part of the subject alone, which is to be approved. This gives us three well-defined departments in the science of the activities of plants: caliology, ecology and physiology.

Physiology, in the restricted sense, deals with the most vital of problems, how the individual lives. It pertains to the way in which plants breathe, secure and use their food, adjust themselves to light, heat, moisture, and the contact of other bodies. It deals with what botanists in the days of Linnæus, and even down to within the last fifty years, would have called the products of the *vis vitalis*. It desires to know what the specific energies of the plant are capable of accomplishing; in short, what is going on within the plant in the way of life processes. As will be readily seen, the whole

matter is summed up in an exhibition of energy, which in former days was called vital energy, and thought to reside exclusively in living organisms, but now held to be only a special manifestation of the general physical forces of the universe.

The energies of plants fall into two categories, those which bring about changes in the intimate structure of vegetable substances, and those which bring about movement; and hence we call physiology a superstructure whose foundation is chemistry and physics. The present great advance in the science may, in large measure, be traced to the wonderful advances in the sciences of chemistry and physics, which have supplied facts and methods to assist the physiologist in his study of life processes.

Yet it would be an egregious mistake to suppose that physiology is but a dependency of chemistry and physics. The substitution of the so-called mechanical philosophy of life for the old vitalistic philosophy has not in any way rendered the vital activities less wonderful, or the protoplasmic display of energy less complex, less inscrutable, or less *sui generis*. The meaning of the word life shows no likelihood of being solved until the chemical and physical constitution of the protoplasmic molecule is understood, and that is too far away to make speculation at this time worth while; and so we need not quarrel with those who fancy that even when that advanced goal is reached the problem will not be solved, but a mysterious residuum will still exist to endow protoplasm with autonomy. Be that as it may, the path of present advancement keeps steadily onward in the clear light of physical laws, and ignores the nearness of of mystical, unfathomable shadows.

But returning from this long digression in separating physiology into the three reasonably distinct sciences—caliology, ecology and physiology proper—we will pro-

ceed with the inquiry regarding the present scientific status and its course of attainment in each of the three branches. It is not, however, any part of my purpose to give a philosophical or historical disquisition upon the subject, but merely to point out a few landmarks to enable us to get our bearings, so that we may spy out the land and obtain some opinion of what there may be good or bad in it.

The subject of caliology, that is, the various phases of juvenescence, including especially the dynamics of the young cell, has not yet received systematic presentation. Although a vast array of facts have been recorded, mostly to be sure as the concomitants of morphological studies and scattered so widely as to be almost lost, yet the value of the subject as a separate inquiry has not yet much impressed itself upon botanical students. There are, doubtless, most excellent reasons for this, not in any wise dependent upon the importance or attractiveness of the subject. The action of a machine as a whole depends upon the interaction of its parts; and to fully understand its operation requires a knowledge of its mechanism. No adequate theory of the physiological processes in the mature organism was possible until the character of the cellular framework and the distribution of tissues had been well worked out; and in the investigation of cellular physiology there occurs the same inherent difficulty. The structure of the cell in all its microscopic detail must be ascertained, and when the microscope fails us there must be well-framed theories of physical organization of the parts before solid advancement in understanding cellular activity can be expected.

The labors of Strasburger have been especially noteworthy in establishing an adequate morphological basis for the interpretation of cellular activity. If we were to point to a single work as particularly con-

spicuous in this connection it would be his *Zellbildung und Zelltheilung* (1875), which introduced hardening and staining methods into the study of the cell, and may be said to have created a new school of histologists, even more conspicuously represented among zoölogists, possibly, than among botanists. Great accuracy and a far clearer interpretation have been attained by the new methods, causing a rapid accumulation of trustworthy facts regarding the parts of the cell, especially of the reproductive cell and its neighbors, and of the succession of changes as the young organism or as the histogenic elements pass toward maturity. In this important work America can count some able investigators and valuable contributions, especially in making known the development of the metaspemic embryo and accompanying changes.

Morphological knowledge of the cell and of the stages in reproduction must necessarily be followed by inquiry into physiological processes. Already the writings of De Vries, Strasburger, Klebs, Vöchting, Wiesner and Vines have indicated the directions for study. The greatest impulse to the physiological study of reproduction, however, has been given by Weismann, although not himself a botanist, and not drawing heavily from the botanical storehouse to support his theories. Nägeli's idioplastic theory of 1884, and De Vries's later theories, have not of themselves been sufficient to arouse botanical enthusiasm. The whole domain of caliology is suffering, in fact, for leaders—men chiefly known for their researches in this field. The science needs a Linnaeus, a Sachs or a Gray to bring it into prominence and to inspire enthusiasm and a following. Some day it will be in vogue.

Upon turning to ecology, we find the conditions wholly changed. There are elements of popularity in the science that have made some of its topics familiar to the general reader, even before the boundaries of

the science have been mapped. The fascinating and epoch-making observations of Charles Darwin on the pollination of orchids and other flowers, at the same time bringing to light the long lost Pompeian-like treasures of Sprengel, gave an impulse to a line of study still full of promise. The extensive writings of Müller, Delpino, and in our own country Charles Robertson, have provided large stores of knowledge, and at the same time opened up attractive vistas for further observation.

Thus we might enumerate many other topics, which are more or less familiar to every one having the slightest acquaintance with botany, and to some others as well. If we ask how these matters came to be so widely known, the answer is not far to seek, and not obscure. The marvellous inspiration which came with the writings of Charles Darwin, and the fact that he cultivated ecological subjects more than any other, together with his theories of adaptation and natural selection which provided a key to the riddles of nature, making what were before matters of course now matters of the liveliest import, turned the attention of the botanical world, and of all other lovers of plants as well, even of some who cannot be placed in either class, in this direction. We may call Darwin the father of vegetable ecology, for had he not written, the field would have lain largely uncultivated and uninteresting.

In America the year 1887 saw the establishment of a series of State institutions, which gave a wonderful influence to the study of ecology. American botany owes much to the Agricultural Experiment Stations, especially in promoting a knowledge of vegetable pathology and ecology. Together with the Agricultural Department of the general government, they have enabled American botanists to become the leading investigators and writers upon pathological subjects, giving a position and imparting a

value to the science of plant diseases, both scientific and practical, that ten years ago would have been inconceivable. What has been done for pathology is likely to be done for ecology, as it is the second subject in importance cultivated by station botanists. In the latter science the assistance of the Agricultural Colleges is also important, for in a few years the subject will undoubtedly hold a commanding position in the curriculum of the agricultural and general science courses of these institutions, and be regarded as the culminating and leading feature of a course of botanical study. It may seem presumptuous and fanciful to claim so much and be so positive in face of the fact that at the present time the subject is a *nomen incognitum* to the makers of curricula in these institutions; but careful examination of the subject-matter of the science shows that even in its present rather chaotic condition it embraces more points of vital interest to the lover and cultivator of plants than other departments of botany, being less recondite, and yet at the same time underlaid with a broad and attractive philosophy. What is most needed at present is a suitable text-book; for the value of the subject will be more quickly recognized when it is displayed in well arranged form.

It would be interesting and profitable to take a survey of the development of the different branches and topics of the science, but I shall content myself with barely mentioning one or two which especially flourish in this country. Recently a new life has been infused into the study of floras and the distribution of plants by what is called the 'biological' method, the inspiration having been derived in the first place from the zoölogists. This method, which has so far been most successfully applied to limited areas in the western part of the United States, undertakes an explanation of the present location of forms by considering severally and collectively the various external and

inherent factors promoting and restricting their development, including the reciprocal influence of proximity. Of the names prominent in this connection, those of Coville, Trelease and MacMillan are especially worthy of mention. The last has done good service by calling attention to the significance of tension lines, in his account of the 'Metaspermæ of the Minnesota Valley.' There is a phase of phylogenetic study which has received some attention of late, in form of the breeding of plants. It is a subject especially adapted to experiment station work. The leader in this line of research, L. H. Bailey, has also materially promoted ecological studies by his numerous biogenetic and other writings.

Coming to physiology, *sensu stricto*, we find the domain of the science so well defined and its several areas so well cultivated that a clear statement of its main problems is now possible. Not much advancement was made before the beginning of the present century. The most notable achievements had been the publication of Hales' brilliant work on the pressure and movement of sap, which introduced the physical side of physiology to the world, and Ingenhousz's equally entertaining volume upon his discoveries regarding the uses of green organs, which introduced the chemical side of physiology to the world. The century was ushered in by Knight's classical essays, in which it was pointed out, among other things, that there was a substantial reason why roots grow downward and stems upward, and by De Saussure's researches upon respiration and other chemico-physiological matters. It is worth mention that Hales, Ingenhousz, Knight and De Saussure were not botanists, although they cultivated botanical subjects; neither were Senebier, Du Hamel, Dutrochet, Liebig, Boussingault and others, who assisted in laying the foundations of the science, but were physicists, chemists and horticulturists. And to

this day much important data is contributed to the science by workers in other fields.

Thus facts accumulated, important discoveries were made, and the mysteries of the life processes in plants were gradually unfolded. But it was not until 1865 that the science was given the commanding position due to it. Then appeared the first treatise which set forth the phenomena and laws of vital processes with due regard to proportion, and with clear philosophical insight. Sachs, in his 'Experimental Physiology,' became the founder of the science in its modern aspect. He set forth with critical discrimination the most important matters pertaining to the organism's relation to light, heat, electricity and gravity, the processes of metabolism, nutrition and respiration, and the movement of water and gases in the plant. With rare foresight he excluded all, or nearly all, topics not strictly belonging within the true scope of the science, and presented the whole subject-matter in an entirely original form, breaking away from the customs of his predecessors and adopting advanced scientific methods. It was an epoch-making book. As Strasburger has recently said in his history of botany in Germany, "the work at once restored vegetable physiology to its place at the center of scientific research."

The book has never been translated into English, and so, while it stimulated the study of physiology in Germany, and physiological laboratories soon became common, led by the famous one at Würzburg, presided over by Sachs, American botany felt little of the new movement until the appearance of Sach's 'Text-book' in English dress a decade later. Even then the new science (for such it was in America) gained but an insecure footing. After another decade, in 1885, appeared the first, and to the present the only, treatise on physiological botany by an American author. This

was written by Goodale in response to the desire of Asa Gray to have the several parts of his 'Text-book for Colleges' expanded into separate treatises in order to more fully represent the status of botanical science. As late as 1872 Dr. Gray contemplated writing the work himself, but his time proving insufficient he assigned the task to his worthy colleague. The title is used in its broad sense, and included histological anatomy, ecology and caliology, as well as physiology proper, the last being by no means the most conspicuous part of the book. The encyclopedic fulness of the work better adapted it for a reference-book to accompany a course of lectures than as a text-book. It greatly helped the science in America however, especially as it stimulated experimental study by a set of laboratory exercises given as an appendix. The year following appeared Vines's 'Physiology of Plants,' in some respects the most philosophical and well-digested presentation of the science yet written in any language; and only a year later still came Sach's new treatise on the same subject. These two works were too bulky to serve well as text-books for undergraduate students, but were a source of inspiration to maturer students and to investigators. The present year, completing the third decade since the physiological epoch began, has seen the altogether admirable, although brief, account of the science by Vines, forming part of his 'Text-book of Botany,' and two excellent laboratory manuals, one by Darwin and Acton, of England, and the other an English adaptation, by MacDougal, of a German work. With these treatises elementary instruction is well provided for, and their effect is already seen in the rapid introduction of the study as a portion of botanical instruction in colleges, and even high schools, throughout the country.

Thus far only the pedagogical side of the science has been brought prominently for-

ward; but what can we say of the research side? So far as America is concerned, there is no research side; the science is equipped and expanded with facts and theories from foreign sources. A few papers embodying original investigations have been published by American teachers, but they were the result of studies carried on in German laboratories. A dozen or two papers have, indeed, been issued from our own laboratories within the last five years, but all of them have been the work of students, mostly in preparation for a degree. America has nothing to show that can in any wise compare with the important discoveries made and still being made by Francis Darwin in England, De Vries in Holland, Wiesner in Austria, or Sachs, Pfeffer, Vöchting, Frank and others in Germany. There are ample reasons why this state of things need not be considered humiliating, and yet it is to be deplored as most unfortunate.

Let us turn to a hasty examination of some of the problems of physiology which await solution. They stand out prominently in every chapter of the science, and suggest to the scientific mind most tempting opportunities for original investigation. The nutrition of plants is so imperfectly understood that it may appropriately be said to be a bundle of problems. So little do we know of the processes that even what constitutes the plant's food is in doubt. We know, for instance, that lime and magnesia are taken into the plant, but whether they are directly nutritive by becoming part of living molecules, or whether they serve as aids to nutritive processes, or become the means of disposing of waste materials within the organism, cannot be definitely stated. And to a greater or less extent similar conditions exist respecting potassium, sulphur, iron and chlorine, which in fact embrace all the so-called mineral elements of plants. The move-

ments and transformations of the two most characteristic elements of organic structures, carbon and nitrogen, are a little better known. Some progress has been made in tracing the steps by which the simple molecule of carbon dioxide derived from the atmosphere is built up into the complex, organic molecule of starch. But the further process by which the starch molecule combines with others to form the most complex and important of all plant substances, protoplasm, is yet an almost complete mystery. The story of the progress of discovery in ascertaining the means by which plants get their nitrogen is a fascinating one, and is not yet ended. These matters in part lie at the very foundation of the most fundamental of industries, agriculture. Intensive farming, and the highest success in the raising of all kinds of crops, is greatly promoted by a knowledge of the nutritive processes in plants. The botanists who thirty-five years ago demonstrated that carbon was taken into the plant through the leaves, and not to any material extent through the roots, struck a theme that revolutionized agricultural practice and added greatly to the wealth of the world. The more recent discovery of the connection of symbionts with leguminous and some other plants, by which the abundant supply of nitrogen in the air is converted into food available for higher plants, has also greatly affected agricultural practice. The whole subject of the nutrition of plants is so bound up with intelligent farming and all manner of plant cultivation that advancement of this part of physiology means an increase in material prosperity as well as in scientific knowledge. Ample provision for its prosecution would be a valuable investment for any people, and particularly so for the people of these United States.

There are many ways in which plants show similar physiological processes to those of animals; and plants being simpler in or-

ganization, their study may often be made to promote a knowledge of animal physiology. The greatest similarity between the two kingdoms lies in various phases of nutrition, respiration and reproduction. The greatest divergence is to be found in the manifestation of irritability. Those fundamental processes upon which being and continued existence depend are much the same throughout animate nature, but the processes by which the organism communicates with the world outside of itself, and through which it is enabled to adjust itself to environmental conditions, the processes which in their highest development are known as sensations, have attained great differentiation, running along essentially different lines of development. The prevalent view that plants occupy an intermediate position between the mineral and the animal kingdoms is not true in any important respect. Neither is it true that the faculties of animals, especially of the lower animals, are foreshadowed in plants. No just conception of animate nature can be obtained by conceiving it to lie in a single ascending series. It constitutes two diverging and branching series, like the blades and stems in a tuft of grass, which we may assume have been derived from a common germ. There are two fundamental characters which manifested themselves early in phylogenetic development, one structural and one physiological. The structural character of the histologic integument of the organism, in animals soft and highly elastic, in plants firm and but slightly elastic, gave rise to the two series of forms, structurally considered, which we call animals and plants. The physiological character of free locomotion for most animals and a fixed position for most plants determined the line of separation for the development of those powers of the organism classed as irritability and sensation. So great have been the differences which these funda-

mental characters have brought about that the stimulating action of external agents, such as light, heat and gravity, have produced very diverse powers in the two kingdoms. Animals have a wonderful mechanism which enables them to see, while plants have a no less wonderfully specialized sensitiveness by which they assume various positions to secure more or less illumination. Animals have a sense of equipoise, but plants have a very dissimilar and even more remarkable sense of verticality. And so on throughout the list of stimuli the reactions are not the same, but are differentiated along entirely separate and divergent lines. The period is fortunately well past when physiology was chiefly cultivated with an *arrière pensée* as to its value for interpreting the functions in man, and hence, in claiming for this department of study the most exalted position, and the most intricate and interesting of botanical problems, we need not be distracted by any lurking *cui bono*, or feeling of having come short of ample returns for conscientious effort, although the facts do not elucidate any point in human or animal physiology. Some of the dissatisfaction which caused G. H. Lewes to abandon the pursuit of his early dreams of a comparative psychology, and M. Foster to discontinue his early study of comparative general physiology, as both authors have assured us they did, may possibly be traceable to a lack of singleness of purpose in taking the good of the organism itself in each grade of development as the point of view in pursuing the study. But as all vital activity rests upon a common basis, it is not improbable that the key to some of the fundamental mysteries of physiological action will yet be found in a study of the well developed functions exhibited in the simpler, nerveless structure of plants, and thus a truer philosophy of life in general be attained.

In closing, a few words in regard to the

future of vegetable physiology in America may not be out of place. In many ways the conditions under which botany exists in America are very different from those in other countries. In Europe the class-rooms are filled chiefly with medical students, for whom a moderate amount of botany is considered essential, and the incentive for advanced work in most instances is not strong. In this country the botanical classes are larger, with more varied interests, of which medicine forms only a small part, and the study usually stands upon the same footing as that of the other sciences. The attainment of equal recognition as a substantial element of an educational course, superseding the notion that it constituted only an efflorescence to be classed with belles-lettres and other refinements, was the beginning of a prosperous period. One of the effects of this prosperity was to make the botanist more jealous of his reputation, and with the beginning of the nineties he entered a vigorous protest against the appropriation by the zoölogists of the terms 'biology' and 'biologist.' It was fair evidence that botanists had awakened to a recognition of common interests with the rest of the world, and of the advantages of keeping well abreast with the times. Later, the systematists, finding that other departments of natural history had devised improved ways for naming natural objects, undertook to fall into line and reform the method of naming plants, which led to the first serious break in unanimity which American botanists have known. So warm has been the contention that a few have descended to personal reflection and invective, which were never before known to mar the amicable adjustment of differences of opinion among American botanists. But this storm is likely to pass and leave the atmosphere clearer, brighter and more invigorating; and it is to be hoped that no trace will remain of an interruption of good fellowship and

general comraderie which has heretofore distinguished the botanists of this country.

It is the broadened horizon for botany in general which makes the outlook for vegetable physiology so especially auspicious. This is the country of all others where its practical and educational importance is likely to be most fully recognized, and where the best equipped and most independent laboratories can most readily be established. One difficulty yet besets it, the difficulty of making known what is needed. Botany has not before required much more than a table near a window for its microscope and reagents, a case for the herbarium and a few shelves for books, and it is difficult to make it understood that the new department needs rooms with special fittings and expensive apparatus. If there were only one well equipped laboratory in the country it might be cited as a model, but even that advantage is yet lacking. It can be explained that the chemical side of the subject needs much of the usual chemical apparatus and supplies with many special pieces, that the physical side requires similar provision, and that many pieces of apparatus are demanded which cannot be obtained in the markets owing to the newness of the subject, necessitating provision for making apparatus of both metal and glass; but the explanation rarely conveys a full appreciation of how essential and extensive this equipment is expected to be. In the fitting of the laboratory there should be rooms for the chemical work with gas, water, sinks and hoods, and rooms for the physical work, with shafting for transmitting power to clinostats and centrifugals, with devices for regulating moisture and temperature, and with as ample provision for light as in a greenhouse. There should also be dark rooms into which a definite amount of light may be introduced by means of arc lamps, and other special rooms for special lines of study. It is easy to see that a well stocked

greenhouse is required to supply healthy plants when needed for study, but the value of a botanic garden may not be so apparent. It need not only be pointed out here, however, that Charles Darwin examined 116 species of plants belonging to 76 genera to prepare his brochure on climbing plants, and it might have been more complete with greater opportunities.

The man who is to preside over a department of this kind, in which research work is to be carried on and instruction undertaken suitable to a university, cannot be one of St. Thomas Aquinas's *homo unius libri*, for physiology touches upon the adjacent sciences to a far greater extent than do other departments of botany, and requires a more intimate acquaintance with a wide range of knowledge.

After careful consideration of the subject, it seems safe to predict that the next great botanical wave that sweeps over America will be a physiological one. As the green chlorophyll grain of vegetation is the great primal storage battery absorbing and fixing the energy of the sun, and making it available for doing the work of the world—in fact, supplying nearly all the power, except that from wind and waters required in commercial enterprise, whether derived finally from animal force, wood, coal, steam or electricity, so the subject which includes the fundamental study of a matter of such universal importance will without doubt eventually attain to a place in public esteem commensurate with its importance.

J. C. ARTHUR.

PURDUE UNIVERSITY.

CURRENT NOTES ON PHYSIOGRAPHY (XVI).
NATIONAL GEOGRAPHIC MONOGRAPHS.

THE fourth number of this series is an essay on the 'Present and Extinct Lakes of Nevada,' by Professor I. C. Russell, of the University of Michigan. This is a serviceable abstract of the fuller treatment of the

subject in Russell's Geological Survey Monograph on Lake Labontan. Besides several figures, it contains a general map, showing the areas of present and extinct lakes, and three maps of larger scale, one of which from surveys by W. D. Johnson exhibits certain details of extinct shorelines with great nicety. All the illustrations are, however, only reproductions of those already published in the survey monograph above mentioned, and thus have less freshness than new illustrations would have.

The fifth monograph is on the 'Beaches and Tidal Marshes of the Atlantic Coast' by Professor N. S. Shaler, of Harvard University. This is for the most part occupied with an account of shore processes rather than shore forms, and is in only a secondary way concerned with the Atlantic Coast. Unfortunately, it has no illustrations, and the number of specific examples of shore forms, described ready for teachers' use, is comparatively small. It seems too much to call our off-shores and-bars 'indestructible shields' of the continent; and to say that upon them the 'ocean waves.....break without effect.'

The sixth monograph, on the 'Northern Appalachians,' by Bailey Willis, of the U. S. Geological Survey, contains a greater amount of new material and new presentation than the two preceding numbers. The region between the Blue Ridge on the east and the Alleghany front on the west is called the 'Greater Valley,' in distinction from the 'Great Valley' of general usage, which does not include the ridge-and-valley area west of the slate and limestone lowland. The general lowland level of the Greater Valley is described as a surface of denudation, and is called the Shenandoah 'base-level;' the ridges rise above it, not yet worn down; the streams traverse it in trenches, excavated since a moderate uplift of the region. The ancient surface, of

which the even uplands and the level crest lines of the ridges are remnants, is called the Kittatinny 'base-level;' this is also recognized as a peneplain, but of ancient date, and now much dissected by the excavation of the valley floors. The three chief divisions of the region 'constitute a group, in which the Blue ridge may be called a continental range; the Greater Valley a tilted litoral zone; and the Alleghany front, which confronts the old continent of Appalachia, an inland-facing 'escarpment.' ['Inface' has lately been suggested as a more compact name for the last mentioned topographic form.] The Shenandoah is shown to have gained length by diverting to its own course the headwaters that once belonged to Beaver Dam creek; Snicker's Gap in the Blue Ridge representing the former outlet of the now diverted headwaters, and the beheaded creek now rising on the eastern slope of the ridge.

THE COMPOSITE ORIGIN OF TOPOGRAPHIC FORMS.

UNDER the above title Prof. A. P. Brigham has contributed an essay to the Bulletin of the American Geographical Society (XXVII., 1895, 161-173) in which he brings together a number of illustrations of the various processes, constructive and destructive, by which the forms of the land are assumed. He emphasizes the importance of this aspect of geographical study: "The teacher of physiography has no greater reward than is his where a student assures him that henceforth his native State will be to him a new country, or that he will see the hills and valleys of his old home with new eyes. . . . Every journey becomes fraught with meaning, and the traveller who has caught the spirit of modern geography will not report the great plains of Kansas and Nebraska as 'uninteresting.' It must, however, still be said that many colleges deny their graduates this appreci-

ative eye. But even the secondary and earlier grades cannot much longer deprive their pupils of this best fruit of geographic study."

TIDAL STREAMS ABOUT THE BRITISH ISLES.

Two small folios of tidal stream charts, one for the North Sea, the other for the west coast of Scotland, have recently been prepared from official material by F. H. Collins (London, Potter, 1894, five shillings each). Each folio contains twelve charts for successive tidal hours. In several localities, as the Strait of Dover and the Frith of Clyde, the opposite movement of the tidal currents is shown within moderate distances; thus exhibiting nicely the origin of the currents in the orbital motion of the water within the tidal wave. The continuance of flood tide after high water, and of ebb tide after low water, commonly observed in straits and estuaries, and puzzling to many vacation observers, is thus simply explained. A series of similar tidal charts for our Atlantic sounds and bays would be an interesting product of our Coast Survey office.

METEOROLOGICAL CHARTS OF THE RED SEA.

THIS atlas contains twenty-four charts, showing chiefly the winds and the currents for every month. They have been prepared by C. A. Baillie, Marine Superintendent of the (London) Meteorological Office (London, Eyre and Spottiswood, 1895; 21 shillings). The charts of the winds are based on 75,000 observations, mostly along the axial line of the sea. The wind roses exhibit both frequency and force. From June to September northwesterly winds prevail over all the Red Sea, with southwesterly winds east of the entrance strait; from October to January there are northerly winds over the northern half, and southerly over the southern half; from February to May the northerlies gain on the southerlies, and

return to summer conditions. The surface currents are irregular, fluctuating with the winds. This is especially marked at the strait, where no persistent surface inflow is indicated, to compensate the deep outflow that has been described as a steady current and ascribed to the excessive salinity of the sea.

W. M. DAVIS.

HARVARD UNIVERSITY.

PRELIMINARY NOTE ON A CONTAGIOUS INSECT DISEASE.

SINCE the establishment, July 1st, at the Illinois State Laboratory of Natural History, of a distinct department for the continuous investigation of the contagious diseases of insects, this work, in which Mr. B. M. Duggar is immediately engaged, has taken two principal directions.

In the first place *Sporotrichum globuliferum* Speg., well known as the fungus of the white muscardine of the chinch bug and of many other insects, was studied oecologically, especially with reference to the effect of exposure of the fungus in its various stages of germination, growth and fruiting for various lengths of time, to a graduated series of temperatures. The troublesome liability of this species to arrest of growth or to complete destruction by drouth, by heat and by cold, together with the fondness which certain prolific field mites have shown for it as an article of food, has led us to search diligently for a bacterial insect disease, presumably less susceptible to these conditions than the muscardines.

Such a disease Mr. Duggar has been fortunate enough to find among a lot of squash bugs (*Anasa tristis*) brought into the laboratory for experimental uses. It has now been clearly shown that this disease is due to a motile bacillus larger than *B. insectorum* Burrill, and of different form, preferably aerobic in habit, but capable, nevertheless, of growing beneath the surface of agar, where the colonies are commonly oval or

fusiform. It spreads over the solid medium freely as a rather thickish film of radiate, lichenose structure and broadly lobate margin.

It multiplies very freely in the blood of insects, doubtless producing there a toxic substance which kills the host, very commonly within two or three days of the first infection. This interpretation of its action is based on the promptly fatal effect produced on small insects by a watery infusion of agar cultures of this bacillus. Young chinch bugs perish in such an infusion in less than a minute, and adults in two or three minutes, while medium-sized caterpillars (*Datana*) dipped into it for ten seconds have begun to writhe and roll in evident distress within two minutes, dying within five or six.

Chinch bugs are readily infected by simple exposure to squash bugs dead with this disease, and die under this infection more promptly, more rapidly, and in larger proportion than if exposed to inoculation with *Sporotrichum*.

S. A. FORBES.

CHAMPAIGN, ILL.

SCIENTIFIC NOTES AND NEWS.

THE 16th and final volume of the first series of the *Index Catalogue* of the library of the Surgeon General's Office of the United States army has now been published. As is well known this is practically a complete index of medical literature, the library now containing 116,847 books and 191,598 pamphlets. The present volume includes 12,759 author titles representing 4,857 volumes and 11,613 pamphlets. It also contains 8,312 subject titles of separate books and 13,280 titles of articles and periodicals. The subjects in the present volumes having the greatest number of entries are water(s), women and wounds. Owing to the large increase in the library since the publication of the index was begun, a second series is needed and the manuscript has

been prepared which will probably make five volumes of the same size and style as those already published. The present volume is probably the last that will be issued under the personal supervision of Dr. John S. Billings, to whom both the catalogue and the library itself are in chief measure due.

ACCORDING to reports in *The British Medical Journal* the milk supply of London is unusually bad. Of fifty samples of ordinary milk examined by Mr. Cassal, twenty-four were found to be below the lowest standard and ten more below the standard requiring 3.5 per cent. of fat. Boric acid preparations had been added to more than one-fourth of the samples. The bacteriological examination made by Mr. Sidney Rowland is still more serious. It showed that every sample examined contained fecal matter, fully 90 per cent. of all the micro-organisms discovered being *bacillus coli communis*.

THE *Revue Scientifique* states that M. Zacharewicz, professor of agriculture at Vaulchuse, has cultivated strawberries under colored glass with the following results: (1) The best and earliest fruits were obtained under ordinary glass. (2) Orange glass increased the leaves but injured the quantity, size and earliness of the fruit. (3) Violet glass gave more berries, but they were small, inferior in quality and late.

MR. DAVID T. DAY, Chief of the Division of Mineral Resources of the United States Geological Survey, has issued a bulletin on the mineral products of the United States for 1885 to 1894. The total value of metallic products during 1894 was \$218,168,788. This shows a decided decrease, the products during 1890, 1891 and 1892 having been over \$300,000,000 in value. The non-metallic mineral products for 1894, of which coal is by far the most important, are valued at \$308,486,774, which is also a decrease compared with the immediately preceding years.

THE cable despatches state that the meetings of the *British Association* opened at Ipswich on September 11th. In the absence of Lord Salisbury, Sir Douglas Galton, the president, was introduced by Lord Kelvin. Sir Douglas is stated to have fainted while reading his address. On his recovery, the remainder of the address was read by Sir John Evans.

MR. H. C. MERCER, editor for Anthropology of the *American Naturalist*, writes in the September number: "I asked the Bishop of Yucatan the question propounded by Mr. Otis T. Mason in *SCIENCE* for August 2, 1895—whether the sandal now in common use among the Mayas, strapped across the instep and fastened further by a single round thong between the first and second toes, was an inheritance from pre-Spanish times. He was unable to answer the question more particularly than to show me from his collection the foot of an earthen statue from Izamal, moulded with a sandal fastened by two toe thongs instead of one. These passed between the first and second and third and fourth toes to reach a strip on the instep. I question whether the existing sandals have been attentively studied in Central America. Some Indians may wear the double toe strap still, but given the existence of the sandal with double toe straps in ancient America, we might reasonably suspect that the old Mayas sometimes used the simpler single thong between the first and second toes, now so common."

THE numbers of the *Lancet* and of the *British Medical Journal* for September 7th are educational numbers being almost entirely filled with accounts of the medical courses in the English universities, schools and hospitals.

Nature states that Prof. John Milne has established a small station at Slide Newport, Isle of Wight, for the study of earthquakes having their origin in distant locali-

ties. Communications respecting the *Transactions* of the Seismological Society and the *Seismological Journal* should be made to Prof. Milne at the above address.

THE 23d Annual Meeting of the American Public Health Association will be held at Denver, Col., October 1st to 4th.

La Nature states that the municipal administration has taken an important step in the development of meteorological study in the district surrounding Paris. M. Joseph Jaubert, founder and director of the Observatory of Saint Jacques, will also undertake the directorship of the Observatory of Montsouris. The observatories will now have increased facilities for coöperation in observing meteorological phenomena. The observatories are 5 kilometers apart, and are connected by telephone.

LONGMANS & Co. have in press the 'Life and Letters of George John Romanes,' prepared by Mrs. Romanes. The book contains many of Romanes' letters to men of science and to private friends, and correspondence between Romanes and Charles Darwin.

ON May 1st of next year an industrial exhibition will be opened in Berlin. The time has been chosen to coincide with the 25th anniversary of a united German Empire.

AT the meeting of the British Dental Association held recently at Edinburgh, under the presidency of Mr. W. Bowman Macleod, the report of the committee on the condition of the teeth of school children showed that in all 11,422 had been examined. The investigations indicated that the teeth of children of the rich were more prone to decay than those of children of the poor.

THE first meeting of the recently organized and incorporated Binghamton (N. Y.) Academy of Science after a vacation of two months was of unusual interest and enthusiasm. A revised constitution drafted by the Executive Council was adopted and ordered printed, together with a list of the

active, associate, corresponding and honorary members, which altogether now number over one hundred. The Society has enrolled in its membership the leading men of science of Binghamton, and is rapidly becoming a potent force in the city. Its object is 'to promote scientific study and research.' Two twenty-minute papers were presented on Saturday evening, one by Rev. J. H. LaRoche, rector of Trinity Church, on 'Christian Socialism;' the other by Arthur T. Vance, of the *Commercial Traveler's Home Magazine*, on 'Professor Huxley: a Biographical Sketch.' The Academy meets in the science room of the high school building on the first and third Saturday evenings of the academic year. At the next meeting Dr. Jack Killen, an oculist and optician, will give a paper on 'Refraction and Lens Making;' and Norman M. Pierce, chemist of the Manhattan Spirit Co., will discuss 'Earth Dust and Star Dust.' The officers of the academy are: President, E. R. Whitney; Vice-President, Herbert J. Jones; Secretary, Willard N. Clute; Treasurer, Fannie Webster; Corresponding Secretary, Dudley T. Greene; Executive Council: the President, the Secretary, Addison Ellsworth, Norman M. Pierce, Arthur T. Vance.

CHAPMAN & HALL will hereafter publish in Great Britain the important scientific and technical publications of John Wiley & Sons.

DR. JOSEPH F. JAMES, formerly Assistant Pathologist in the United States Department of Agriculture, has resigned his position and will in future practice medicine.

THE North Carolina Experiment Station has published a report of the weather in 1894. It describes the work of the State weather service and its several agencies, the meteorological observing stations, the signal display stations and the crop reporting systems. The latter dis-

tribute weekly the weather crop bulletin, the signal stations display flags to note the coming of cold waves and frost warnings and changes in the weather, while the observing stations furnish observations for securing a correct record of the climate and weather. People living on the low grounds of certain rivers are warned of the approach of floods. The number of places supplied with weather forecasts is nearly 500. The crop correspondents reporting for the weekly weather crop bulletin number 350 from all of the 96 counties. The meteorological observing stations number 73 in all parts of the State.

GINN & Co. have in press *Problems in Differential Calculus*, by Professor W. E. Byerly, of Harvard University.

THE first part of an *Encyclopedie Therapie*, edited by Professor Oscar Liebreich with the coöperation of Drs. M. Mendelssohn and A. Würzburg, has been published by August Hirschwald, Berlin. The works will be issued in nine parts, making three volumes.

THE third French Congress of Medicine will be held at Nancy in 1896, under the Presidency of M. Pitres, Dean of the Faculty Medicine of Bordeaux.

THE New Maryland Asylum, for the colonization of the incurably insane of the State, will be located in Springfield.

UNIVERSITY AND EDUCATIONAL NEWS.

MAXEY HALL, a new dormitory at Brown University, was opened by a reception given by President Andrews on the afternoon of September 13th. The hall contains, in addition to 36 students' apartments, 8 recitation rooms and rooms for the Herbarium.

THE *Medical Record* states there were 19,048 medical students registered in Italy in 1894-95. The number of universities is twenty-one, and the number of students registered at the various universities varies

from 3,697 at Naples to 87 at Milan. The percentage of medical students to the population is about 61 per 100,000 inhabitants. In France it is 57 per 100,000, and in Germany 63 per 100,000.

THE Cambridge University Calendar for the academical year 1895-6 gives as the total number of undergraduate students 2,895, an increase of 56 compared with last year.

MISS HELEN GOULD has founded two scholarships of \$5,000 each in the University of the City of New York.

MRS. FRASER, widow of the late Bishop of Manchester, has bequeathed £3,000 to Oriol College, Oxford, for the foundation of a scholarship; and also £3,000 to Owens College, Manchester, towards the endowment of a chair of ecclesiastical history.

DR. LINGI PALAZZO, of *Officio Centrale di Meteorologia e di Geodinamica*, Rome, has been made a professor.

DR. BEHREND, of Leipzig, has been called to the chair of chemistry in the Technical High School of Hanover, and Dr. Roher to an assistant professorship in the University of Prague.

IT is stated that Dr. Nathaniel Butler, of Chicago University, has declined the presidency of Colby University.

PROF. W. S. STRONG, of the University of Colorado, has accepted a professorship of physics and geology in Bates College.

THE will of the late Benjamin P. Cheney bequeathes \$10,000 to the Massachusetts Institute of Technology.

THE Catholic University has decided to admit women to lectures in the regular and special courses.

IT is stated that the Hon. Carroll D. Wright will give a course of lectures on political economy during the coming winter in the McManon Hall of Philosophy of the Catholic University.

CORRESPONDENCE.

ARE CONSEQUENCES EVER A TEST OF TRUTH?

I AM glad that Professor Cattell (*SCIENCE*, N. S., II., p. 271-2) has taken me at my word in regard to criticisms of recent articles; even though I may be the first to suffer. In my recent article in the *Monist* I had spoken of evil consequences as a reason for rejecting the view that natural selection is the only factor in social evolution. On this Professor Cattell remarks: "But even if these practical consequences follow, one is surely not justified in arguing that facts do not exist because we would gladly have them otherwise."

Now I admit that Professor Cattell may be right from a scientific point of view, but not, I think, from the widest philosophic point of view. This opens a very wide question, but hardly adapted to a scientific journal. I can, therefore, touch it very lightly and only in the way of barest suggestion; and even so I fear I shall raise more questions than I solve.

It is indeed true that many things which we, from the point of view of *the now and the self*, would gladly have otherwise are nevertheless true; yet I do not think that a doctrine or idea which, if carried out, would be disastrous to humanity as a whole and in the final outcome can be true. If it were, then our intellectual and moral natures would be in hopeless conflict and we ourselves in a state of irretrievable confusion.

Or put it in another way: There are certain postulates which are a necessary condition of our effective activity in this world. We cannot prove them; we assume them because necessary to our activity. We assume the existence of the external world as a necessary condition of *physical* activity. We assume a rational order of the universe—a universal reign of law—as a necessary condition of scientific activity. We may not be able in a particular case to see law and rational order; on the contrary, all may seem chaos and confusion, but we are sure that this seeming chaos is the result of our ignorance and that behind it is perfect order. So, also, there are postulates of our *moral nature*, postulates because absolutely necessary conditions of our *moral* activity. Such a postulate is the existence of a universal *moral order*—a perfect

righteousness—behind all seeming moral disorder and evil. I repeat, then, that whatever is a necessary condition of our highest activity—whatever is contributive to the best interests of our whole humanity and in the *final outcome*—must be in some sense true. I am quite aware that we are often mistaken as to what ideas come under this head, but we are mistaken only through a too limited and personal view.

Therefore, in a true philosophy, we cannot wholly leave out consequences. It would be irrational to do so. "But observe; I speak of consequences only as a *test* of truth. I would not swerve a hair's breadth in absolute devotion to truth. Whatever is really true will surely vindicate itself as such by its beneficence, if we only wait patiently for final results."*

So much for the principle criticised. Nevertheless, I freely admit that I may be wrong in thinking that these dire consequences would follow if natural selection be the only factor in social evolution. There may be, and indeed I am sure there is, a natural selection of fittest ideas and institutions, and thereby a gradual improvement of the social environment, which must be a powerful factor of progress, and of which I did not take sufficient account. But to show that I have not been wholly unmindful of this factor I quote from a recent paper:† "Ideas are like species. In the evolution of thought, some indeed become extinct and have no progeny, but some are transformed into new, and all the new come only by such transformation of the old."

BERKELEY, CAL.

JOSEPH LE CONTE.

THE KATYDID'S ORCHESTRA.

TO THE EDITOR OF SCIENCE: Possibly the phenomenon I am about to describe is well known to biologists, but to me it is unknown, and it seems so remarkable that it is worth recording. It is the only instance I know of in nature of any continued attempt at concerted harmony and measured time-keeping on the part of many animals. With all the musical or sound-mak-

ing capacities of animals none seems to have much of an idea of measured time-beating, and in no instance known to me is there any attempt of large numbers to unite the individual notes into a common musical result. The universal fact of preserved individualism, and indifference to unisonal effect, is a noteworthy one when we consider the high degree of musical sense with which some animals are endowed.

Probably every person would express disgust at the idea of the stridulous noise of the Katydid being musical, and surprise at the suggestion that there is any rhythm or unison in many of them, but for weeks the fact has been all too apparent to my family for the purposes of sleep. Our house has been upon a mountain top in North Carolina, surrounded by a grove of trees, and farther away by woods upon all sides. So soon as the sun has set and twilight is advancing, the katydids in the trees begin to 'tune up.' The first notes are scattered, awkward, and without rhythm, but if no wind is blowing, thousands soon join in and from that time until daylight breaks there is no intermission. It is marvellous that the organs can withstand this continual rubbing for eight hours. By choosing out an insect close by and listening to it alone I have convinced myself that the same insect keeps at it at least for hours at a time. These raspings are seldom three at a time, as the popular name would imply, but are the result of usually four or five, sometimes six, distinct but closely joined movements. When united with a thousand others the disjunction of these tones is, of course, not perceptible, and they sound like a single note. In order to make my description clearer, let us suppose one thousand Katydids scattered through the trees to utter their several notes all at once, and call them Company A. Another thousand, Company B., at once answers them, and this swing-swung is kept up, as I say, all night. Company A's note is the emphatic or accented note, and is more definitely and accurately a precise musical note, whilst the note of Company B varies from one to five half tones below, the most conspicuous note being five. In the old-fashioned musical terms I learned as a boy, Company B's note is *e. g.*, clearly and definitely *do*, while the note of Company B is either *la*, or more cer-

* 'Evolution and its relation to religious thought,' p. 279.

† Geol. Dep't, University of California, Bull. No. 11, p. 336.

tainly *sol*, below. Not only is Company A's note more unisonal and definite, but it is firmer, more accented, and it seems to me that more insects join in this note than in the second. Careful observation has convinced me that no insect of Company A or Company B ever joins in the other company's note. The rhythm is usually perfect unless there is a disturbance by a breeze. A sharp gust upsets the whole orchestra and confusion results, but the measured beat is soon refound. In the instants of confusion one can detect the steady see-saw of certain ones, as it were, 'leaders,' or 'first violinists,' who hold the time-measure despite the wind, and who soon draw the lost notes of the others once more into the regular measure or beat. I do not mean to say that by diligent attention one may not at times detect individuals sawing out of time, stray fellows that are indifferent or careless, but the vast majority usually even seemingly without a single exception, if there is no wind or rain, thus swing along hour after hour in perfect time. I have counted the beats several times and find the number is always identical, 34 double beats or 68 single ones in 60 seconds. The effect of the rhythm upon the mind is not unlike that of the woodsman's cross-cut saw handled by two steady, tireless pairs of hands, although the Katydids give a larger volume of sound and the *timbre* is harsher. The queries arise: Is Company A composed of males and Company B of females? What function does the orchestration subserv? Is there anything comparable to it among other animals?

Sincerely yours,

GEORGE M. GOULD.

HIGHLANDS, MACON COUNTY, N. C.

SCIENTIFIC LITERATURE.

A Text-Book of Physiology by M. FOSTER, M. A., M. D., LL. D., F. R. S. Professor of Physiology in the University of Cambridge and Fellow of Trinity College, Cambridge. Revised and abridged from the author's text-book of physiology in five volumes. New York, Macmillan & Co. 1895.

We remember the third edition of Dr. Foster's celebrated text-book with gratitude and affection. It was different from other books then in common use. This book had style to begin

with; and style is a rare quality in such writings. It had an air of being at the center of things. There was a certain glow of enthusiasm in its pages, breaking through at times what seemed the habitual restraint of a scholar who was also a man of the world. Such moments were very welcome. Not less welcome were the brief accounts of celebrated controversies. How we venerated the name of Ludwig! What high resolves were stirred by the triumphs of Bernard, Heidenhain, Marey and Du Bois-Reymond! How amazingly clever were Goltz and Gaule to have thought of measuring the pressure in the heart with a minimum valve! These were not merely the easily excited reactions of impressionable youth. Fourteen years have passed since those delightful days and have but strengthened our belief that this was a most stimulating and helpful book.

The first, second and third editions were much alike. They set forth 'that which is fixed and sure, without too much display or too much neglect of that which is uncertain and loose.' They introduced in smaller type discussions on debated points. The fourth edition and its successors differ from the earlier volumes. The discussions on debated points are either left out or much abridged or are transformed by the omission of the references to original sources. In the preface to the fourth edition Dr. Foster explained that his decision to do away with the small print portions of former editions had been largely determined by the fact that this former pupils, now his colleagues at Cambridge, had undertaken to join with him in treating these higher or advanced parts of physiology in a more extended and satisfactory form. The hope that the result of their labors would soon appear led him to omit all references and to use as little as possible the personal authority of the names of investigators. "The fondness of students for the use of names of persons is as marked as the pertinacity with which they use them wrongly."

The hope which the author here expressed is fulfilled in the fifth edition, in which Dr. Gaskell, Mr. Langley and Dr. Lea have given great assistance. The result is a work of about two thousand pages in five volumes. Part I. treats of the blood, the contractile tissues and the vas-

cular mechanism; Part II., of the tissues, of chemical action with their respective mechanisms and of nutrition; Part III., of the central nervous system and its instruments; Part IV., of the senses and some special muscular mechanisms and of the tissues and mechanisms of reproduction; and Part V., the appendix, of the chemical basis of the animal body.

The abridged edition recently issued is in one volume of about twelve hundred pages. The abridgment, we are told in the preface, has been effected by omitting all the histological matter, and all discussions of a too theoretical nature. The appendix is also omitted. Otherwise, beyond such changes as the advance of science seems to call for, the text which is left is the same as in the full edition.

In forming an opinion about a text-book, two questions must be answered: first, whether the plan on which the book is made is the best possible plan; second, whether the workmanship is good. The second question we may dismiss at once. The work is admirably done. Experience and painstaking are seen in every page. About the plan we cannot be so sure. A text-book of physiology should form and develop scientific habits of thought, make clear the danger as well as the suggestive value of hypotheses, harden the student against the shock of controversy by teaching the value of evidence and especially the criticism of method, and in short create a state of mind. If this be the aim, facts will take care of themselves. They are relatively unimportant. The trained student retains many of the facts which have been the raw material of his training and can easily get more. The untrained is merely encumbered by information. These principles are fundamental, yet how seldom are they practically applied. Many a widely sold text-book of physiology is a weak encyclopedia, a medley of facts. Dr. Foster's book is not of this sort. Its chief excellence is that it strives to develop as well as to inform the mind.

It may be questioned whether the recent editions serve this purpose as well as the third edition. The omission of references to original sources, the lack of historical account and the repression of controversy do not strengthen the book, while the more extended treatment for

the sake of which chiefly these things have been done threatens to be too much for the undergraduate and is certainly too little for the advanced student. We loved the third edition for its personal quality. We find the fifth impersonal, less vivid, remote. The history of a few of the more famous discoveries in physiology, the rise of a few famous doctrines, the fall of others, the general outlines of one or more of the controversies of the day, are, in our opinion, indispensable to the correct rendering of that subtle atmosphere which is the very spirit of the science. Much of this there already is, but its force is weakened by the absence of personal reference. The facts of physiology, particularly recent facts, are seldom altogether separated from the personality of their discoverer, and they cannot be wholly divorced without breaking a sympathetic link, a human interest, highly valuable as an intellectual condiment. An impersonal statement of the records secured by the self-registering apparatus of a captive balloon is less interesting to the ordinary student than the observations made at a great height by the aeronaut himself.

However, this may be, there is no gainsaying the general opinion that Dr. Foster's work is the most satisfactory yet written. Wide knowledge, a fine sympathy, the gift of style and a delicate sense of balance are necessary to the making of such a book. W. T. PORTER.

HARVARD UNIVERSITY.

North American Birds: By H. NEHRING. 4°, part XII., Sept. 1895, pp. 145-192, pls. 22 and 23. Published by Geo. Brumder, Milwaukee, Wis.

The twelfth part of the American edition—for there is a German edition also—of this excellent work has been delivered to subscribers. It contains two colored plates—one a superb picture of the Black-breasted Rosy Finch (*Leucocitæ atrata*) from the brush of Robert Ridgway; the other a conglomeration of sparrows by Mützel.

The text deals with the sparrows and finches and includes some of the commonest and best known of American birds—as the Long Sparrow—and also some of the rarest species—as Abert's Tomhel. The accounts of some of the

Western birds are largely at second hand and not very complete, while those of the species with which Mr. Nehrling is personally familiar—comprising the great majority—are full and show a real knowledge of the birds' haunts and habits. Mr. Nehrling is a botanist as well as an ornithologist, and many of his biographies tell more of the flowers and shrubs among which the birds live than of the birds themselves.

It is gratifying to see this meritorious work pressing so rapidly toward completion.

C. H. M.

SCIENTIFIC JOURNALS.

THE AMERICAN GEOLOGIST, SEPTEMBER.

Edward Hitchcock: By C. H. HITCHCOCK. President Hitchcock's name is thoroughly identified with the subject of ichnology and the Connecticut sandstone. To him belongs the honor of having proved the existence of a large fauna of giant bipeds and quadrupeds in the Trias of New England from their footmarks. The sketch of his life is accompanied by a portrait and an extended bibliography.

A Rational View of the Keweenaw: By N. H. WINCHELL. The author continues his discussion of the Keweenaw from last month's number of this journal. His conclusions are briefly as follows: The so-called basal eruptives (gabbros, etc.) of the Keweenaw are pre-Keweenaw, and are separated from the Keweenaw by a long erosion interval. The lowest beds of the Keweenaw are conglomerates and sandstones, and not igneous rocks. With these basal clastics are included the Sioux, New Ulm and Baraboo quartzites. (This seems to be the first time that these quartzites have been assigned to the Keweenaw.) There is not sufficient evidence of a long erosion interval between the Keweenaw and the Upper Cambrian. The Animikie is Lower Cambrian in age, and the Olenellus horizon is separated from the Paradoxides horizon by the disturbance that closed the Animikie. The Keweenaw eruptive age, following the accumulation of the conglomerates and quartzites above mentioned, separated the Paradoxides horizon from the *Dicelloccephalus* horizon.

The Mentor Beds: A Central Kansas Terrane of the Comanche Series: By F. W. CRAGIN. These

beds, named from a small station in Saline county, Kansas, are a terrane of variegated earthy textured marine shales, with intercalated beds of brown sandstone, resting in part conformably upon the Kiowa shales, and in part unconformably upon the Permian. They are succeeded by the sediments of the Dakota. They were formerly considered by all geologists as constituting a part of the Dakota group, but are now known to belong to the upper part of the Comanche series. The Mentor beds are characterized by a fauna (which is here listed) related to that of the Denison beds, and still more closely to that of the Kiowa shales, with the latter of which its stratigraphic relation is close.

The Larval Stages of Trilobites: By CHARLES E. BEECHER. A common early larval form of trilobites is recognized and called the *protaspis*. It has a dorsal shield, a cephalic portion composed of five fused segments indicating as many paired appendages, and a pygidial portion consisting of the anal segment with one or more fused segments. The simplest larvæ are those of Cambrian genera. In later geologic time the *protaspis* acquired additional characters by earlier inheritance, as the free-cheeks, the eyes, the eye-line and ornaments of the test.

On account of the antiquity and generalized nature of the trilobites, their ontogeny is of considerable importance in interpreting crustacean phylogeny. The *protaspis* and crustacean nauplius are shown to be homologous larval forms, and the latter to have potentially five cephalic segments bearing appendages. The nauplius is considered as a modified crustacean larva. The *protaspis* more nearly represents the primitive ancestral larval form for the class, and approximates the protonauplius.

Recent Geological Work in South Dakota: By J. E. TODD. Prof. Todd, State Geologist, presents in a brief letter some points of general geological interest ascertained during this season's work in the Black Hills and in the north-western part of the State.

THE ASTROPHYSICAL JOURNAL, AUGUST.

A New Form of Stellar Photometer: EDWARD C. PICKERING. A new photometer has been devised with special reference to the comparison

of stars some distance apart. The double-image prism is placed at the focus and the two images of the object glass are formed by two achromatic prisms which can be slid to any desired distance from the focus. A Foucault prism and eyepiece are placed behind the double-image prism. With this instrument stars $35'$ apart may be brought together. This form is recommended for large telescopes for determining the brightness of the fainter stars.

On the Forms of the Disks of Jupiter's Satellites: S. I. BAILEY. Observations made at Arequipa during the early part of the year indicate that under the best conditions, II., III. and IV. are always seen round. I. was twice observed to have an elongation, in each case being near the planet.

Note on the Magnesium Band at λ 5007: H. CREW and O. H. BASQUIN. This fluting upon being photographed plainly showed its bands to have a linear structure. A table gives the wave-lengths of the main lines.

Note on the Spectrum of Carbon: H. CREW and O. H. BASQUIN. This confirms the work of Kayser and Runge in showing by independent evidence that the three carbon bands at λ 4216, λ 3883 and λ 3590 were due to cyanogen.

The Measurement of some Standard Wave-lengths in the Infra-red Spectra of the Elements, II.: EXUM PERCIVAL LEWIS. In this second paper on the investigation of the infra-red spectra with the radiometer, measurements are given of lines due to calcium, strontium and thallium.

Preliminary Table of Solar Spectrum Wave-lengths, VII.: HENRY A. ROWLAND. The table is continued from λ 4903 to λ 5148.

Résumé of Solar Observations made in 1894 at the Astrophysical Observatory of Catania: A. MAS-CARI. The months richest in the various phenomena were May for spots and pores, July for groups of spots and pores and for prominences, and September for faculæ. The prominences and faculæ have been more numerous in the southern than in the northern hemisphere. A marked maximum for the faculæ occurs between 10° and 20° . There is a secondary maximum in the southern hemisphere between 60° and 70° , and a decided minimum in the polar regions. From the tables it is concluded that the secondary maxima of prominences of 1893 have moved toward

the equator, while the absolute maximum has moved nearly 10° south. The phenomena of prominences and faculæ have not been always in complete accord.

A Spectrographic Determination of velocities in the System of Saturn: W. W. CAMPBELL. The work of the new Mills spectrograph on the Saturnian system has been a confirmation of that of Professor Keeler.

On the Existence of a Twilight Arc upon the Planet Mars: PERCIVAL LOWELL. Micrometric measures of the equatorial diameter of Mars in November showed an increase over those made in October when the planet was nearer opposition, while the polar diameter remained practically unchanged. From this the author argues the existence of a twilight arc of 10° upon Mars.

Spectroscopic Observations of Colored Stars: FRIEDRICH KRUEGER. This is a list of observations of such colored stars as have not hitherto been examined spectroscopically and of those which required a review because of former dubious results.

Minor Contributions and Notes: Preliminary Note on the Radiation of Incandescent Platinum. The Visible Spectrum of the Trifid Nebula. Note on the Spectrum of the Aurora Borealis. Observations of the B Band in Stellar Spectra. Note on the Spectroscopic Proof of the Meteoric Constitution of Saturn's Rings. Photograph of the Nebula near λ 2 Orionis Made at the Astrophysical Observatory of Colonia. Note on the D_3 Line in the Spectrum of the Chromosphere. Étienne-Léopold Trouvelot. The Belgian Astronomical Society.

NEW BOOKS.

The Alps from End to End. SIR WILLIAM MARTIN CONWAY. Westminster, Archibald, Constable & Co. New York, Macmillan & Co. 1895. Pp. xii+403. \$7.00.

Icebound on Kolguev. AUBYN TREVAR BATTYE. Westminster, Archibald, Constable & Co. New York, Macmillan & Co. 1895. Pp. xxviii+458. \$7.00.

An Introduction to the Study of Zoology. B. LINDSAY. London, Levan, Sonnenschien & Co. New York, Macmillan & Co. 1895. Pp. xii+356. \$1.60.

SCIENCE

NEW SERIES.
VOL. II. No. 39.

FRIDAY, SEPTEMBER 27, 1895.

SINGLE COPIES, 15 CTS.
ANNUAL SUBSCRIPTION, \$5.00.

GUSTAV E. STECHERT'S Recent Importation of Scientific Books.

BECKERT, TH. und DR. ALBANO BRAND. Hüttenkunde. Mit 235 in den Text gedruckten Figuren. 765 Seiten. gr. 8°. Mk. 20.

BEHRENS, H. Anleitung zur mikrochemischen Analyse. Mit einem Vorwort von Prof. S. Hoogewerff in Delft. 224 Seiten mit 92 Figuren in Text. 8°. Mk. 6.

BIEDERMANN, W. Elektrophysiologie. 1^{te} Abtheilung. Mit 136 Abbildungen. 440 Seiten. 8°. Mk. 9.

BORCHERS, DR. W. Elektro-Metallurgie. Die Gewinnung der Metalle unter Vermittlung des elektrischen Stromes. 2^{te} verm. v. völlig umgearb. Auflage. 1^{te} Abtheilung, mit 87 Abbildungen. 160 Seiten. gr. 8°. Mk. 6⁰⁰.

BUSCHAN, GEORG. Vorgesichtliche Botanik der Cultur-u. Nutzpflanzen der alten Welt auf Grund prähistorischer Funde. 268 Seiten. 8°. Mk. 7⁰⁰.

DAMMER, DR. O. Handbuch der chemischen Technologie. Unter Mitwirkung von Direktor Th. Beckert, Dr. Bender, Dr. Benedikt, Dr. Börnstein u. A. herausgegeben. 2^{tes} Band. Mit 235 in den Text gedruckten Figuren. gr. 8°. Mk. 20.

DELAGE, YVES. La structure du protoplasma et les théories sur l'hérédité et les grands problèmes de la biologie générale. 878 pages. gr. 8° cloth. frs 24⁰⁰.

DETMER, DR. W. Das pflanzenphysiologische Praktikum. Anleitung zu pflanzenphysiolog. Untersuchungen für Studierende u. Lehrer der Naturwissenschaften, sowie der Medicin, etc. 2^{te} völlig neubearbeitete Aufl. Mit 184 Abbildungen. 456 Seiten. 8°. Mk. 9.

FOREL, DR. AUGUST. Der Hypnotismus, seine psycho-physiologische medicinische, strafrechtliche Bedeutung und seine Handhabung. 3^{te} verb. Aufl. mit Adnotationen von Dr. O. Vogt. 223 Seiten. gr. 8°. Mk. 5.

FRANK, DR. A. B. Die Krankheiten der Pflanzen. Ein Handbuch für Land u. Forstwirte, Botaniker, etc. Erster Band, Die durch anorgan. Einflüsse hervorgerufene Krankheiten. Mit 34 Holzschnitten. 2^{te} Aufl. 344 Seiten. 8°. Mk. 6⁰⁰.

HIS, WILH. Die anatomische Nomenclatur. Nomina anatomica, Verzeichniss der von der anatomischen Gesellschaft auf ihrer 9. Versammlung in Basel angenommenen Namen. Mit 30 Abbildgn. im Text und 2 Tafeln. 180 Seiten. Mk. 7⁰⁰.

HOUDAILLE, F. Météorologie agricole. 204 pages cloth. fr. 3.

JAHRBUCH DER ELEKTROCHEMIE. Berichte über die Fortschritte des Jahres 1894. Im wissenschaftlichen Theile bearbeitet von Dr. W. Nernst. Im technischen Theile bearbeitet von Dr. W. Borchers. 1^{er} Jahrgang. 274 Seiten. gr. 8°. Mk. 10.

JERUSALEM, WILH. Die Urtheilsfunction. Eine psychologische und erkenntniskritische Untersuchung. 269 Seiten. Mk. 6⁰⁰.

LOEWY, DR. A. Untersuchungen über die Respiration and Circulation bei Aenderung des Druckes und des Sauerstoffgehaltes der Luft. Mit 5 Curventafeln im Text. 155 Seiten. gr. 8°. Mk. 4.

MEYER, DR. ARTH. Untersuchungen über die Stärkekörner der höheren Pflanzen. Mit 9 Tafeln u. 99 Text-Abbildgn. 318 Seiten. gr. 8°. Mk. 20⁰⁰.

NIEDENZU, DR. FRANZ. Handbuch für botanische Bestimmungsübungen. Mit 15 Figuren im Text. 351 Seiten. 8°. Mk. 4.

SCHAFFER, DR. KARL. Suggestion und Reflex. Eine Critisch-experimentelle Studie über die Reflexphänomene des Hypnotismus. Mit 6 Tafeln in Lichtdruck und 11 Abbildungen im Text. 113 Seiten. gr. 8°. Mk. 6⁵⁰.

SCHMIDT, DR. ALEX. Weitere Beiträge zur Blutlehre. Nach des Verfassers Tode herausgegeben. 247 Seiten. 8°. Mk. 7.

SCHWARTZE, TH. Die Lehre von der Electricität und deren praktische Verwendung. Mit 153 in den Text gedruckten Abbildungen. 543 Seiten. 8°. Mk. 10⁰⁰.

STEINHARDT, DR. EUGEN. Kurzes Lehrbuch der Chemie zum Gebrauch an Schulen und zur Selbstbelehrung. Zwei Theile. Erst. Theil; Anorganische Chemie. 418 Seiten. 8°. Mk. 6⁰⁰.

VAN BIERVLIET, J. J. Elements de psychologie humaine. Cours professé a l'université de Gand. Avec 34 figures dans le Text. 317 pages. frs. 8.

ZEITSCHRIFT FÜR ANGEWANDTE MIKROSKOPIE herausgegeben von G. Marpmann. Monthly. 1^{ter} Band 1^{tes} Heft. Per year, \$2.75.

ZEITSCHRIFT, Geographische, Herausgegeben von Dr. Alfred Hettner. 1^{er} Jahrg. 1^{er} Heft. Per year (12 N^{os}) \$4⁰⁰.

ZIMMERMANN, DR. A. Das Mikroskop. Ein Leitfa-den der wissenschaftlichen Mikroskopie. Mit 231 Figuren im Text. 334 Seiten. gr. 8°. Mk. 9.

ZITTEL, KARL A. VON. Grundzüge der Paläontologie (Paläozoologie). Mit 2048 in den Text gedruckten Abbildungen. 971 Seiten. gr. 8°. ½ mor. Mk. 25⁰⁰.

GUSTAV E. STECHERT,

810 Broadway, New York.

Macmillan & Co.'s New Publications

Nitti. Catholic Socialism.

By FRANCESCO S. NITTI, Professor of Political Economy at the University of Naples, author of "Population and the Social System," etc. Translated from the second Italian edition by MARY MACKINTOSH. With an Introduction by DAVID G. RITCHIE, M. A., Professor of Logic and Metaphysics in the University of St. Andrews. Pp. xx + 432, 8vo, cloth, \$3.50.

Lindsay. An Introduction to the Study of Zoology.

By B. LINDSAY, C. S., of Girton College, Cambridge. With 124 Illustrations and Diagrams. Pp. xix + 356, 12 mo, cloth, \$1.60 net.

Cooke, Shipley and Reed. Molluscs and Brachiopods.

By REV. A. H. COOKE, M. A., Fellow of King's College, Cambridge; A. E. SHIPLEY, M. A., Fellow of Christ's College, Cambridge; and F. R. C. REED, B. A., Trinity College, Cambridge. Illustrated. *Cambridge Natural History*. 8vo, cloth, pp. 535, \$3.25 net.

Conway. The Alps from End to End.

By SIR WILLIAM MARTIN CONWAY. With 100 Illustrations by A. D. MCCORMICK. Large demy 8vo, cloth, \$7.00.

Bastable. Public Finance.

By C. F. BASTABLE, M. A., LL.D., Professor of Political Economy in the University of Dublin. Second Edition. Revised and enlarged. 8vo, cloth, \$4.00 net.

"An Arctic Adventure."

Trevor-Battye. Ice-Bound on Kolguev.

By AUBYN TREVOR-BATTYE, F. L. S., F. Z. S., etc. With numerous Illustrations and Drawings, and Three Maps. Large 8vo, cloth, gilt top, \$7.00.

Watson. Hedonistic Theories, from Aristippus to Spencer.

By JOHN WATSON, Professor of Moral Philosophy in the University of Queen's College, Kingston, Canada. 12mo, cloth, \$1.75 net.

Jackson. The Great Frozen Land.

Narratives of a Winter Journey across the Tundras and a Sojourn among the Samoyads. By GEORGE F. JACKSON, Fellow of the Royal Geographical Society and Leader of the Jackson-Harmsworth Polar Expedition. With Illustrations and Maps. Edited from his Journals by ARTHUR MONTEFIORE. 8vo, cloth, pp. xviii + 297, \$4.50.

NEW VOLUMES.

The Century Science Series.

Edited by SIR HENRY E. ROSCOE.

Justus Von Liebig: His Life and Work. By W. A. SHENSTON, Science Master in Clifton College. 16 mo, cloth, \$1.25.

The Herschels and Modern Astronomy.

By MISS AGNES M. CLERKE, author of "A Popular History of Astronomy in the 19th Century," etc. 16mo, cloth, \$1.25.

Already Published.

John Dalton and the Rise of Modern Chemistry.

By SIR HENRY E. ROSCOE, F. R. S., etc. 16mo, cloth, \$1.25.

Major Rennell, F. R. S., and the Rise of English Geography.

By CLEMENTS R. MARKHAM, C. B., F. R. S., etc. 16mo, cloth, \$1.25.

The Rural Science Series.

Edited by L. H. BAILEY. New Volume.

King.—The Soil. Its Nature, Relations and Fundamental Principles of Management. By F. H. KING, Professor of Agricultural Physics in the University of Wisconsin. 16mo, cloth, 75 cents.

The Function of Criticism at the Present

Time. By MATTHEW ARNOLD. Reprinted from "Essays in Criticism." **An Essay in Style.** By WALTER PATER. Reprinted from "Appreciations." In one Vol., 18mo, cloth, 75 cents; paper, 25 cents.

Wright.—Birdcraft.

A Field Book of Two Hundred Song, Game and Water Birds. By MABEL OSGOOD WRIGHT. With numerous full-page Plates containing 128 Birds in the Natural Colors, and other Illustrations. 8vo, bound in linen, \$3.00 net.

MACMILLAN & CO., 66 Fifth Avenue, New York.

SCIENCE

EDITORIAL COMMITTEE: S. NEWCOMB, Mathematics; R. S. WOODWARD, Mechanics; E. C. PICKERING, Astronomy; T. C. MENDENHALL, Physics; R. H. THURSTON, Engineering; IRA REMSEN, Chemistry; J. LE CONTE, Geology; W. M. DAVIS, Physiography; O. C. MARSH, Paleontology; W. K. BROOKS, Invertebrate Zoölogy; C. HART MERRIAM, Vertebrate Zoölogy; S. H. SCUDDER, Entomology; N. L. BRITTON, Botany; HENRY F. OSBORN, General Biology; H. P. BOWDITCH, Physiology; J. S. BILLINGS, Hygiene; J. MCKEEN CATTELL, Psychology; DANIEL G. BRINTON, J. W. POWELL, Anthropology.

FRIDAY, SEPTEMBER 27, 1895.

CONTENTS:

| | |
|---|-----|
| <i>The American Forestry Association:</i> F. H. NEWELL | 385 |
| <i>Society for the Promotion of Engineering Education.</i> | 390 |
| <i>The Second Summer Meeting of the American Mathematical Society:</i> THOMAS S. FISKE..... | 394 |
| <i>The Springfield Meeting of the American Association for the Advancement of Science:—</i> | 397 |
| <i>Section A. Mathematics and Astronomy:</i> ASAPH HALL, JR. <i>Section E. Geology and Geography:</i> EDMUND OTIS HOVEY. <i>Section G. Botany:</i> B. T. GALLOWAY. <i>Section I. Economics.</i> | |
| <i>Scientific Notes and News</i> | 407 |
| <i>University and Educational News</i> | 409 |
| <i>Correspondence:—</i> | 411 |
| <i>Alleged Suppression of Discussion:</i> J. MCKEEN CATTELL. <i>Examination of the Blood in Disease:</i> JOSEPH F. JAMES. | |
| <i>Scientific Literature:—</i> | 413 |
| <i>Mach's Mechanics:</i> D. W. HERING. <i>Allen's Collection of Mammals from Arizona and Mexico:</i> C. H. M. <i>La sensibilité de l'œil aux couleurs spectrales:</i> E. C. SANFORD. | |
| <i>Scientific Journals:—</i> | 419 |
| <i>The Physical Review.</i> | |
| <i>New Books</i> | 420 |

MSS. intended for publication and books, etc., intended for review should be sent to the responsible editor, Prof. J. McKeen Cattell, Garrison on Hudson, N. Y.

Subscriptions and advertisements should be sent to SCIENCE, 41 N. Queen St., Lancaster, Pa., or 41 East 49th St., New York.

THE AMERICAN FORESTRY ASSOCIATION.

THE American Forestry Association held its summer meeting at Springfield, Massachusetts, on September 4th and 5th, in connection with the American Association for the Advancement of Science.

The President of this Association, the Hon. J. Sterling Morton, Secretary of Agri-

culture, was prevented by official business from attending, but sent his regards together with expressions of deep interest in the objects of the meeting.

Capt. Francis H. Appleton, Vice-President, from Massachusetts, presided and opened the session by a brief address detailing the condition of forestry in Massachusetts and referring to the action of the State Board of Agriculture through its Forestry Division. The first business was the appointment of Messrs. Fernow, Higley, Moses, Walker and Appleton as a Committee on Resolutions to report at the end of the session. The Hon. G. F. Talbot, of Maine, made an address in which he advocated that all worthless lands forfeited by tax sales be permanently held by the State and devoted to the purpose of the production of trees, such lands being admirably adapted to this end. He spoke of the fire laws of Maine and stated that the adverse interests of forest owners was the great obstacle to any reform in the proper control. Under a sharp competition the land was stripped of everything salable and the refuse left where it happened to fall, thus ultimately becoming through its inflammability a menace to all neighboring property.

Mr. George H. Moses, Secretary of the New Hampshire Forestry Commission, reviewed the history of legislative attempts to provide suitable protection to the forests, and spoke of the creation of the present

Commission organized to investigate the extent and character of the forest cover, the removal of lumber, the annual receipts and the general relation of forests to climate, water and health. They are empowered simply to investigate, but much of their energy has been given to attempts to convince the lumber men that it is for their personal interest as well as that of the State to introduce less wasteful and destructive methods. They are also striving to preserve some of the natural beauties of the White Mountain region, as the summer resorts, if destroyed or injured, will cause great annual loss to the State.

Mr. Joseph B. Walker, of Concord, New Hampshire, followed with a description of the present condition of the forests, especially those in the northern portion of the State. Here large areas are owned by individuals whose sole object is to make the most money in the shortest period, and who have no interest in obtaining a future crop of trees. Everything is cut which can be sold, either for lumber or matches. Vast sections are denuded one after the other, the fires in the 'slashings' sweeping the ground clean after the lumber men have left. There is a beginning, mainly from the sentimental side, to make an attempt to prevent this great destruction, and the fire laws have been so improved that the Selectmen or County Commissioners are required to appoint fire wardens, whose duties include the watching for fires and the summoning of aid to prevent their spread. No penalty for failure is provided, but popular sentiment is being aroused to such an extent as to render the law generally effective. The farmer is beginning to appreciate the necessity of the forests, as these if properly managed will furnish him opportunity for labor during the winter months. At present he labors seven months of the year and from his farm alone cannot derive revenue for the remaining five months.

Rev. Julius H. Ward, of the editorial staff of the Boston *Herald*, read a paper on the present situation in the White Mountains. He noted the increased regard being expressed by lumbermen for the young trees which ultimately should become valuable for lumber. He described the ordinary operations and stated that the companies now at work in the White Mountains expected to cut everything before them, not leaving a stick of any value.

Mr. Charles Eliot, of the firm of Olmstead & Eliot, of Brookline, Mass., read a paper on the new public forests near Boston, illustrating this by maps of the locations of these forests, and described their general characteristics. The most important of these public reservations is the Blue Hills area, consisting mainly of rugged hills and swamps. Next in importance are the Middlesex Falls, and besides these are numerous smaller localities notable for the beauty of their scenery. The chief enemy to these is fire, and to guard against this, the larger reservations are blocked out into fire districts, and watchmen employed to patrol the grounds.

Mr. E. H. Forbush, Director of Field Work of the Gypsy Moth Department of the Massachusetts Board of Agriculture, spoke of the work in confining this insect pest within certain limits. It originated in specimens imported by an entomologist, these escaping and multiplying until the trees and bushes within many towns were destroyed as completely as by fire. By means of sufficient appropriations it would be possible to exterminate this insect, but Massachusetts has only granted a sum sufficient to hold it in check. Thus there is constant danger that the moth may escape and start new colonies in every direction. If allowed to spread it may overrun the whole country. He stated that the native birds will not eat the eggs of this insect, but that possibly some foreign birds which

eat the eggs in their own country might be imported.

Mr. Cornelius C. Vermeule, of the New Jersey Geological Survey, read a paper upon forests and rivers, this relating mainly to the conditions within the State of New Jersey, reference being made to data from Massachusetts, New York and Pennsylvania. In his conclusions he stated that the river measurements failed to indicate any notable effect of forests upon evaporation or upon the very highest or lowest rate of flow. The measurements do show what is quite as important, namely, a more equable flow, fewer floods, and shorter periods of extreme low water upon well forested catchments. Some of Mr. Vermeule's conclusions were called in question by Mr. Fernow as not being applicable beyond the areas studied.

Hon. Warren Higley, of New York, spoke of the progress of legislation in his State, and described the inception and growth of the Adirondack Park. The lands within the Park limits are being acquired by the State through tax sales or by purchase, excepting such as are owned or controlled by clubs or corporations whose interests in forest protection are identical with those of the State. It was the original intention to manage this Park upon rational principles and dispose of the ripe trees for timber wherever this could be done without injury, but the Constitutional Convention adopted a provision against the sale of any timber upon lands owned or to be acquired by the State, the people thus putting themselves upon record as being able to buy and maintain these forests without the aid of revenue from the sale of forest products.

Colonel William Fox, Superintendent in charge of the State Forests, briefly described the organization of the Commission under which he was employed, and stated that it was the intention to purchase 80,000 acres as soon as possible. The forests could un-

doubtedly be improved by cutting, but since this was prohibited by the Constitution, a rational system of forestry must be held in abeyance for the present.

Prof. J. C. Smock, State Geologist of New Jersey, stated that some of the largest land holdings in that part of the country are in southern New Jersey. The Geological Survey is performing, to a certain extent, some of the functions of a forest commission and is making examinations as to the relation of forests to water supply and sanitary conditions. The agricultural interests are as a rule subordinate in New Jersey to the question of water supply, especially in the northern part of the State, where are situated the great metropolitan districts. For the southern part the main source of anxiety is the forest fires, one of these alone having burned over and destroyed probably a million dollars' worth of lumber and other property. Such a fire leaves only the bare white sand, destroying even the soil.

Baron Beno Reinhardt von Herman, Chamberlain to the King of Württemberg, Forestry Councillor and at present Attaché Forestry and Agriculture to the German Legation, read a brief address upon forestry management in Germany, and spoke of the special education of the foresters in colleges devoted to this purpose, and their subsequent training by practical experience in the woods.

The remaining papers on the program for Tuesday were not read owing to the absence of their authors. Adjournment was taken till Wednesday, September 4th.

On Wednesday morning, September 4th, the session was called to order by Vice-President Appleton, the first paper being by Mr. T. S. Gold, Secretary of the Board of Agriculture of Connecticut. He spoke of the causes tending to re-establish wood growth in his State, these being mainly the decrease of profit in wood cutting, owing to the extinction of the iron furnaces. Many

trees are being set by the roadside and the State has enacted legislation protecting such trees. Spikes having the letter 'C' in the head are to be provided, and when driven into one of the roadside or shade trees this spike must not be removed even by the owner, and any destruction or injury to the tree is punishable by heavy penalty. The drought of the past year has destroyed many trees, especially the chestnut, resulting in widespread injury to woodlands.

Dr. B. G. Northrop, of Clinton, Connecticut, described the interest shown in Arbor Day in the Hawaiian Islands and in Japan, at the time of his visit to those countries. In Japan the Emperor's birthday has been designated as Arbor Day, memorial trees being planted in his honor. Great enthusiasm was expressed and interest shown in the reclamation of sea coast and the planting of the sand dunes.

A letter from the Hon. J. Sterling Morton, President of the Association, was read. This called attention to the necessity of urging upon the State legislation compelling the proper care of waste from timber cutting in order to prevent forest fires. Mr. Morton also wrote of the necessity of bringing about coöperation between the United States Geological Survey and the Forestry Division of the Agricultural Department, in order that during the preparation of the topographic map the forest areas might be properly represented. He showed that by slight additional expense it would be possible for an expert to classify the woodlands while the map was being made, and obtain the material for a report upon the condition and value of the forests, and the steps to be taken for the proper protection or treatment of these resources. By this means the completed map would show not only the altitude and slopes of the country, the roads, trails and improvements, but also the character and extent of the timber.

Mr. F. H. Newell, Secretary of the Asso-

ciation, spoke of the progress of the great map of the United States now being prepared by the United States Geological Survey, and described the methods of representing wooded areas, dwelling upon the benefits which would follow the more accurate designation of timber lands. By suitable coöperation of the Agricultural Department, it might be possible to concentrate efforts upon the areas covered by the national forest reservations and complete the mapping and description of these within a few years. Remarks were made by Messrs. Talbot, Moses, Elwyn, Pinchot, Smock and others, showing the inaccuracy of the present information concerning the forests and the difficulties of obtaining exact facts through local officials.

Mr. George T. Powell, of Ghent, New York, spoke upon the benefit to the farmers of the preservation of forest areas. He stated that too many unproductive acres were now cultivated, and that in the Eastern States often the cost of production exceeded the value received. By tilling a smaller number of acres with greater care, and devoting the poorer lands to the growth of timber far larger results might be obtained.

At this point Mr. Appleton resigned the chair to Hon. Warren Higley, Vice-President for New York. A discussion was entered into as to the necessity and value to this Association of a forestry journal. This was participated in by Messrs. Fernow, Newell, Talbot, Ward and Pinchot, the general opinion being that such a journal was highly desirable, provided the editorial and business management could be undertaken by any competent person. On motion of Dr. G. B. Northrop the matter was referred to the Executive Committee, with power to act.

Mr. B. E. Fernow, Chief of the Forestry Division, at the beginning of the afternoon session made a statement as to the progress

in National forestry legislation and reviewed the history of attempts made in the past to secure passage of bills endorsed by this Association.

Mr. R. U. Johnson, of the *Century Magazine*, then spoke of the action of the New York Board of Trade and Chamber of Commerce, and urged the advisability of endorsing the resolution of that body calling for the creation by Congress of a Forestry Commission, consisting of three persons empowered to examine into the forest conditions of the country.

Mr. Gifford Pinchot then read a paper upon the present condition of the National forests and the necessity of action in protecting these. He held that since past efforts of this Association had been in a large degree ineffectual, that the proper method of procedure was through a Forest Commission such as that proposed by Mr. Johnson. His views were strongly controverted by Mr. B. E. Fernow on the ground that the time was ripe for action rather than for investigation, and that Congress would be more likely to consider legislation already discussed during the past session rather than to take a backward step in the appointment of a Commission. The matter was urged by Messrs. Johnson and Pinchot, and under a suspension of the rules the following resolution was adopted:

Resolved, That we, this Association, join with the New York Chamber of Commerce and Board of Trade in hearty advocacy of the establishment of a Forestry Commission of three members to make a thorough investigation of the public forest lands and to make recommendations concerning their disposition and treatment, and the Executive Committee is hereby directed to represent the Association in support of such legislation.

Prof. Dwight Porter, of the Massachusetts Institute of Technology, read a paper upon the fluctuations of water supply in Con-

necticut river and the possible connection between these and forest removal. His general conclusion was that as far as the flow of the lower river is concerned there is no proof of permanent injury through cutting of the forests at the head waters. Mr. Talbot called attention to the fact that taking the basin as a whole there might be at present as much growing timber as formerly since on this point there are no statistics available.

Mr. Leonard W. Ross, of Boston, read a paper upon seacoast planting as practiced on the Province lands of Cape Cod, and described the attempts being made to prevent the shifting sands at the extremity of Cape Cod from injuring the settlements and harbor. He spoke of the various kinds of grasses and shrubs which have been planted to hold the sands, and of the results attained, and exhibited specimens showing the cutting of the twigs due to the sand carried by the wind.

Mr. H. C. Bliss, of Springfield, Massachusetts, read a description of methods of planting trees in the vicinity of his city. He has planted an average of 100 trees a year for over twelve years, and has had great success in thus adding to the beauty of the various streets. He described his methods and offered many practical suggestions.

Mr. John M. Woods, of Boston, Mass., described the changes in the hard wood trade during the past thirty years, and spoke of the uses of the more valuable of the ornamental woods native in the eastern and southern parts of the United States.

Hon. G. F. Talbot presented a formal invitation from the Governor of Maine and the Mayor of Portland, inviting the Association to hold a meeting at Portland, Maine, during the next summer. Invitations were referred to the Executive Committee for action.

The Committee on Resolutions then made its formal report, and the following resolu-

tions were adopted paragraph by paragraph, after which the Association adjourned:

Resolved, That the American Forestry Association learns with satisfaction of the recent enactment of laws for the protection of forest property against destruction by fire in Wisconsin and Minnesota, and of the successful operation of such laws in Maine, New Hampshire and New York, deprecating at the same time the continuance of forest destruction by fire in other States and especially on the public domain.

That the question of dealing with forest fires is still the first and most important one to be settled in nearly all the States of the Union before rational forestry methods can become practicable.

That inasmuch as forestry property is taxed for the support of government, it has the same right to consideration and protection as other property and that the Legislatures of the different States which have no efficient forest-fire laws are recommended to provide the same.

That the policy of establishing forest reservations and parks is to be encouraged, and for this purpose it is recommended that timber lands offered for sale for non-payment of taxes be acquired by the State and held to form the nucleus of State forest reservations.

That it is the first duty of Congress in regard to the public timber lands to enact proper legislation for the National protection and administration of the forest reservations and unreserved timber lands, and we appeal to the Public Lands Committees of the Senate and House of Representatives to secure the passage of bills which received the sanction of the Senate and House of Representatives in the 53d Congress, and failed to become laws only for lack of time for consideration of amendments in conference.

That the American Forestry Association, recognizing that a practical advance in

rational forestry methods requires the services of men trained in forestry practice, indorse the legislation proposed in the last Congress by Mr. Hainer, and expresses the hope that the same will be enacted during the coming Congress.

That the knowledge of the extent and conditions of our forest resources is a necessary basis for intelligent forest legislation, and that therefore the American Forestry Association recommends the coöperation of various government departments as far as practicable in ascertaining these areas and conditions, and especially recommends that both a topographic and forestal survey of National Forest Reserves be instituted.

F. H. NEWELL,

Corresponding Secretary.

WASHINGTON, D. C.

SOCIETY FOR THE PROMOTION OF ENGINEERING EDUCATION.

The second annual meeting of the Society for the Promotion of Engineering Education was held at Springfield, Mass., on Sept. 2, 3 and 4. This Society was organized in 1893 at the close of the session of the educational section of the International Engineering Congress, whose proceedings were published in the first volume of its transactions. It had 156 members at the close of the meeting held in Brooklyn in 1894. The sessions of the Society are largely devoted to the discussion and reading of papers, nearly all the business being transacted by a Council composed of 21 members, selected from 21 different engineering colleges.

The President of the Society, Professor George F. Swain, opened the first session with an address on the relation between mental training and practical work in engineering education. He alluded to the strong tendency toward practical engineering work as often dangerous in preventing a thorough educational development. The opinions of the public and of some engineers are often

directly opposed to those of teachers of long experience, and hence the importance of the discussions in this Society. Principles are more important than rules, and a broad foundation gives the best opportunity for success. The success of the middle-aged engineers of to-day, who had few opportunities for practical work during their college courses, is perhaps largely due to their broad and thorough training in fundamental subjects. The selection of teachers on the basis of practical experience alone seems a dangerous one. In short, education is more important than engineering in the school and college.

The report of the Secretary, Professor J. B. Johnson, brought out the fact that a considerable number of copies of the two volumes of transactions had been sold in Europe, and that the methods of laboratory instruction in the United States had formed the subject of a lengthy discussion in the Society of Engineers and Architects of Germany.

REQUIREMENTS FOR ADMISSION.

The Committee appointed at the Brooklyn meeting to collect facts regarding the requirements for admission to engineering colleges presented a report of progress through its chairman, Professor F. O. Marvin. Circulars had been sent to every engineering college in the United States and Canada and 55 replies had been received, which were tabulated in five groups by States. The New England, Middle and Central States are strong in mathematical requirements, over 50 per cent. in each of these groups requiring algebra through quadratics and plane and solid geometry, while in the West and South only 24 and 4 per cent., respectively, require the same amount. The Central States are much stronger in science requirements than the other groups, 14 colleges requiring an average of three or more science subjects. In

advanced English requirements the Eastern colleges are the strongest. In foreign languages the central group stands highest. Drawing is required by only ten per cent. of all the colleges, and the larger part of these are in the Central or Western States.

In all the groups there is seen a strong tendency to increase the mathematical requirements, to abandon formal grammar and substitute a better knowledge of the English language and literature, and to introduce either French or German.

As to the conditions allowed and the time for their removal the replies show that the practice is subject to wide variation. The same is the case with respect to the acceptance of certificates in place of examination. It is significant, however, that out of 55 colleges 34 should report the certificate plan as more or less satisfactory.

Circulars were also sent to nearly 500 preparatory schools and 148 replies were received. Of these 59 think an increase in the requirements for admission to engineering colleges is desirable, and 75 are prepared to advance their courses to meet such an increase; 105 schools favor uniformity in requirements. With respect to the certificate plan only one-third think that it should be extended, those in the East favoring examinations and those in the South and West favoring admission by certificate.

The Committee refrained from presenting opinions upon the facts collected, and it was continued in order to further study the material on hand and report at the meeting in 1896.

PAPERS ON SEPTEMBER 2.

'The Scope of an Engineering School,' by Professor William G. Raymond, took the ground that culture and language studies should be mostly confined to preparatory courses, and that mathematics, except arithmetic, should be left to the engineer-

ing college. Here algebra and geometry should be begun and a broad and thorough training be given in general and technical science, while the specialties of engineering, like bridge and locomotive design, should be left to a post-graduate year. These views met with decided opposition from Mr. William Kent, who advocated geometry, algebra and Latin as most important subjects to be taught in the high schools.

'The Requirements of Engineering Colleges in Non-professional Studies,' by Professor Louis E. Reber, gave statistics relating to 37 institutions. The various subjects were classed as culture, indirect technical and technical. The average time devoted to culture studies was given as 16 per cent., while the technical subjects occupy from 50 to 60 per cent. Three colleges have no language studies in their technical courses, although requiring more or less for admission. The tendency toward specialization in engineering work seemed marked, one institution having no culture studies of any kind in the entire four years of the course.

'Graphic Methods in Engineering Education,' by Professor L. M. Hoskins. This paper urged the importance of more thorough instruction, not only in graphic studies, but also in general analysis by graphics. It was claimed that geometry often yields almost wholly to algebra as an instrument of investigation and that this results in a lack of clearness. The discussion on this paper developed the general opinion that technical students are usually very weak in arithmetical computations, and that graphic methods should not be used for cases where a slide rule gives sufficient precision.

'The Elective System Applied to Courses in Mining,' by Dr. M. E. Wadsworth, gave an outline of the method adopted at the Michigan Mining School. The discussion on this paper by several members indicated that elective courses in engineering were

not in general regarded with favor, as the proper sequence of studies can not be thus well maintained. The experience of the Massachusetts Institute of Technology was cited as tending to a restriction of the elective system.

'Specifications for Text-books,' by Professor Ira O. Baker, treated of the principles which should be kept in view in preparing a text-book. Typographical arrangement, subdivisions, nomenclature and notation were discussed in a suggestive manner. The practice of publishers in bringing out volumes with wide margins was somewhat severely criticised in the discussion which followed, as also was the practice of inserting appendices filled with matter clipped from periodicals.

'The Place of Drawing and Shop Work in Engineering Schools,' by Professor C. H. Benjamin. This paper advocated a prominent place for free-hand drawing, it being regarded as equally important with mechanical drawing. Shop work should be taught to illustrate principles as well as for the advantages of manual training. Students should be required to pay for work that they spoil. The educational value of both drawing and shop work was regarded as high. In the discussions of this paper the methods of the workshops of the Worcester Polytechnic Institute were described by the Superintendent.

PAPERS ON SEPTEMBER 3.

'Theses and Degrees,' by Professor Storm Bull, was a plea for the propriety of giving the bachelor's degree at the completion of a course of technical study. The professional degree of civil or mechanical engineer properly demands a thesis of a different character from that prepared for the bachelor's degree, and should be given only after two or three years of practice. If a third degree is advisable after advanced study it should be Doctor of Engineering

rather than Doctor of Philosophy. The discussion which followed showed a general agreement with these views; it also brought out opinions that theses are of great educational value and that they should be prepared by students with little or no assistance from instructors.

'Modified Requirements for Students who have taken full Liberal Courses,' by Professor Ira N. Hollis. This paper claimed that, with a proper arrangement, a classical graduate could complete an engineering course in one or two years. The greatest difficulty in doing this seems to lie in the fact that the teaching of mathematics in liberal courses is conducted without reference to practical applications.

'Graduate Study in Engineering Courses,' by Professor William H. Burr, asserted that the value of these graduate courses is small compared with those in literary institutions. Four years of study in college is sufficient for most men who intend to follow the practice of engineering.

'The Economic Element in Technical Education,' by Professor L. S. Randolph, advocated the discussion of the commercial side of engineering problems, and the undesirability of making computations to an unnecessary degree of precision. A study of questions of cost is often of essential importance, engineering being in fact the art of economic construction.

'Unsymmetrical Development of the various courses in Engineering Colleges,' by Prof. F. R. Hutton, favored a strong executive control in order to prevent one department from growing at the expense of others.

'The Engineer of the Twentieth Century,' by Elmer L. Corthell, was a vigorous plea for more thorough education on a broad systematic plan. Technical education was claimed to possess special advantages in training the mind so as to render it capable of being of most service to society and humanity. The boys of to-day who are to be

engineers of the twentieth century were advised to secure a broad, liberal education before beginning the special study of engineering.

The afternoon of September 3d was devoted to a visit of inspection to the dam under construction at Holyoke, and also in observing the testing of turbines at the works of the Holyoke Water Power Company.

PAPERS ON SEPTEMBER 4.

On the morning of this day five papers on courses in the physical sciences were presented. Professor C. L. Mees discussed Physics, dwelling upon the importance of precision of nomenclature and in the use of units of measurement, also claiming that dynamics should properly be a part of the course in physics. Professor G. C. Comstock treated of Astronomy, showing the value of the precise training in observation and computation to every engineer. Professor R. S. Woodward's paper on Mechanics dwelt on the fundamental definitions and concepts, particularly those of force, mass and acceleration. These papers led to many interesting discussions by T. C. Mendenhall, Wm. Kent, J. Galbraith and others.

A second class of papers treated of the professional studies in engineering courses, of the subjects and the time to be given to each. Professor C. L. Crandall gave a tabulation of these for the course in civil engineering. Mr. C. C. Brown, city engineer of Indianapolis, discussed a course in sanitary engineering, claiming such specialization to be highly advantageous. Professor Mansfield Merriman, in discussing geodetic engineering, expressed his opposition to a specialized four years' course in this subject, saying that the aim should be, not training in a trade, but education, that is, the development of the powers of the mind. The discussion on these papers brought out

many opinions in opposition to trade specialization in engineering colleges, and many others in favor of thoroughness and precision in all technical work.

'Mechanical Engineering,' by Prof. H. W. Spangler, presented statistics showing the lines of work followed by graduates of mechanical engineering courses; out of 587 graduates all but 9 had followed their chosen profession. The relative importance of laboratory and shop work was treated at length.

'Mining Engineering Laboratories,' by Professor H. O. Hofmann, fully detailed the equipment and methods of work in the laboratories of the Massachusetts Institute of Technology, where 325 hours of practical work are required of each student in mining.

'A Course of Instruction in Engineering Materials,' by Professor J. B. Johnson, gave a comprehensive outline of both the theoretic and practical divisions of mechanics of materials, the laboratory work recommended being about fifty hours in length. The proper kinds of testing machines for the use of students received an extended consideration in the discussion.

The five sessions of the meetings were not sufficient for the reading of all the papers presented; three were read by title, their authors being absent. The time for discussion also often proved too limited. Perhaps the most interesting discussion of the session was that between the engineers and the physicists regarding the units of force best adapted for use in the teaching of mechanics.

THE NEXT MEETING.

It was decided to hold the next annual meeting at Buffalo, beginning on August 20, 1896. The following officers were elected: President, Mansfield Merriman, of Lehigh University; Vice-Presidents, F. O. Marvin, of the University of Kansas, and Cady Staley, of the Case School of Applied

Science; Secretary, C. Frank Allen, of the Massachusetts Institute of Technology; Treasurer, J. J. Flather, of Purdue University.

The number of new members elected at this meeting was 33, thus bringing the total membership to 189, representing about 75 technical colleges. The number of members and guests present at the Springfield meeting was nearly 100. There is now little doubt but that the Society will have a great and lasting influence in shaping the development of engineering education.

THE SECOND SUMMER MEETING OF THE AMERICAN MATHEMATICAL SOCIETY.

THE Second Summer Meeting of the American Mathematical Society was held in the High School building at Springfield, Mass., on August 27th and 28th. Among those present were: Prof. A. L. Baker, Dr. J. H. Boyd, Prof. C. H. Chandler, Prof. L. L. Conant, Prof. C. L. Doolittle, Prof. W. P. Durfee, Prof. E. Frisby, Dr. G. D. Gable, Dr. J. W. L. Glaisher, Prof. A. Hall, Jr., Prof. Ellen Hayes, Dr. G. W. Hill, Prof. W. Woolsey Johnson, Mr. P. A. Lambert, Prof. J. McMahon, Prof. M. Merriman, Prof. F. Morley, Prof. H. B. Newson, Prof. W. F. Osgood, Prof. M. I. Pupin, Mr. R. A. Roberts, Mr. C. H. Roekwell, Prof. J. B. Shaw, Prof. W. E. Story, Prof. H. Taber, Prof. J. M. Van Vleck, Prof. E. B. Van Vleck, Prof. C. A. Waldo, Prof. H. S. White, Prof. J. M. Willard, Prof. C. B. Williams, Prof. F. S. Woods and Prof. R. S. Woodward.

The President, Dr. G. W. Hill, occupied the chair. Two sessions were held each day, meeting respectively at 10 A. M. and 2:30 P. M. The following papers were read:

1. *The periodic solution as a first approximation in the lunar theory:* DR. G. W. HILL.
2. *The linear vector operator of quaternions:* PROF. J. B. SHAW.
3. *A new application of quaternions to geometry:* PROF. J. B. SHAW.

4. On a generalization of Weierstrass's equation with three terms : PROF. F. MORLEY.
5. Formulas for the sides of rational plane triangles : DR. ARTEMAS MARTIN.
6. Partial linear transformations of ternary quantities and their concomitants : PROF. J. MCMAHON.
7. An introduction to the integrell calculus : PROF. W. H. ECHOLS.
8. On the expansion of a uniform function of a real variable without use of derivatives : PROF. W. H. ECHOLS.
9. On continuous functions without differential coefficients : MR. P. A. LAMBERT.
10. Concerning Jordan's linear substitution groups : PROF. E. H. MOORE.
11. Algebraic symbols and $\sqrt{-1}$: PROF. A. L. BAKER.
12. An application of the method of conformal representation to the study of related differential equations : PROF. E. B. VAN VLECK.
13. On the differential equations of certain systems of conics : MR. R. A. ROBERTS.
14. On bilinear forms : PROF. H. TABER.
15. Elementary proof of the quaternion associative principle : PROF. A. S. HATHAWAY.
16. Asymptotic lines on a circular ring : PROF. H. MASCHKE.

Dr. Hill's paper at the time of its presentation was already in type for publication in the *Astronomical Journal*. Its object is to obtain the values of the coefficients of the periodic inequalities having the multiples of the mean angular distance of the Moon from the Sun as arguments when the inclination of the lunar orbit and the two eccentricities are neglected. It is very desirable to have these coefficients with a high degree of accuracy in order to effect their useful employment in the further determination of the motion of the perigee and node, and in fact of all the other coefficients of the periodic inequalities. This work has been done previously by the author in the *American Journal of Mathematics*, Vol. I., but in neglecting the lunar mass and the solar parallax. Mr. Ernest W. Brown has in the same journal supplemented these researches, but still leaving out of consideration the mass of the Moon.

Professor Shaw's first paper is a development of the linear vector operator of qua-

ternions in the form of a scalar part and two vector parts, also as a tensor and a versor, and finally as a sum of nine operators. The forms are similar to those obtained in the articles of Professor Taber (*Amer. Jour. Math.*, Vols. 12, 13), but are here developed entirely from quaternion expressions and not from matrices. It was stated that this paper would be offered to the *American Journal of Mathematics* for publication.

Professor Shaw's second paper applies the quaternion calculus to homogeneous geometry of two dimensions. In the expression $\zeta = xi + yj + zk$, x, y, z , are proportional to the areas PBC, PCA, PAB respectively, where the point P is referred to the fundamental triangle ABC . By this convention propositions of projective geometry are easily proved, and especially such propositions of modern geometry as those of the Lemoine-Brocard type. The author expected to contribute this paper to the *Annals of Mathematics*.

Professor Morley's paper will be published in the *Bulletin of the American Mathematical Society*. It contains a simple generalization of the formula

$$\begin{aligned} & \sigma(u+u_1) \sigma(u-u_1) \sigma(u_2+u_3) \sigma(u_2-u_3) \\ & + \sigma(u+u_2) \sigma(u-u_2) \sigma(u_3+u_1) \sigma(u_3-u_1) \\ & + \sigma(u+u_3) \sigma(u-u_3) \sigma(u_1+u_2) \sigma(u_1-u_2) = 0 \end{aligned}$$

In Dr. Martin's paper a large number of formulæ are deduced for calculating rational numbers which represent the sides of triangles having a rational area. Among them are, for the case of a right angled triangle,

$$x=2pq, \quad y=p^2-q^2, \quad z=p^2+q^2,$$

and, for the case of an oblique triangle,

$$\begin{aligned} x &= (p^2+q^2)(r^2-s^2), \\ y &= 2rs(p^2+q^2) \pm 2s^2(p^2-q^2), \\ z &= (p^2+q^2)(r^2+s^2) \pm 3rs(p^2-q^2), \end{aligned}$$

in which x, y, z denote the sides, and p, q, r, s , any entire numbers whatever. The paper, which contains many numerical applications, will be printed in the *Mathematic-*

al Magazine. In the absence of Dr. Martin his paper was read by the Secretary.

Semi-invariants of a ternary quadratic satisfy some, but not all, of the six differential equations which characterize invariants. Professor McMahon's paper shows how to distinguish between those semi-invariants which are the sources of covariants and those which are the sources of semi-covariants, and gives a simple method of deriving from the latter all the coefficients of the semi-covariant, or of a semi-contravariant if desired. A systematic geometrical interpretation of these three kinds of semi-concomitants is presented and appears to be particularly useful in cartesian coordinates. This paper is intended for the *Annals of Mathematics*.

In the absence of Professor Echols his two papers were presented by the Secretary. The first one was the second section of an essay 'On the Differell and Integrell Calculus,' the preceding section having been read at the May meeting of the Society. Professor Echols approaches the infinitesimal calculus from the calculus of finite differences. He considers the latter, however, in a greatly generalized form. A differell is defined to be the limit of a ratio whose terms are the n -th differences of the function and the independent variable. An integrell is a differell of a negative index. The applications presented consisted chiefly in the expansion of functions in terms of differells and integrells. In the second paper some of the more novel results were translated into the language of ordinary calculus.

Mr. Lambert attempted to show that functions of which Weierstrass's derivativeless function is the type may be so considered geometrically that their curves will have determinate tangents. In order to secure agreement of the analytic result with the geometric he found it necessary to replace Weierstrass's limitation of h ,

$$\frac{1}{2} \frac{\pi}{a^n} < h < \frac{3}{2} \frac{\pi}{a^n}, \text{ by } 0 < h < \varepsilon \frac{\pi}{a^{2n}},$$

n increasing indefinitely, and ε being any finite quantity.

In Professor Moore's paper a tactical configuration is established which exactly defines Jordan's linear substitution group when taken fractionally. This configuration is self-reciprocal. The properties of this configuration and of other allied configurations similarly related to certain important subgroups of the main group are developed. Professor Moore's paper will appear in the *Bulletin of the American Mathematical Society*. It was presented at the meeting by the Secretary.

Professor Baker's paper contained a detailed discussion of the character of the operations of algebra and the theory of imaginary quantities. It will be published in the *American Journal of Mathematics*.

In Professor Van Vleck's paper an aggregate of regular linear differential equations of the second order is taken, each of which has a polynomial solution. The requirement is made that these equations shall have a common group arising from their four common branch points; in Riemann's phraseology, that they shall be related. This requirement necessitates the introduction of one accessory branch point into each equation. These accessory points do not, however, give rise to any substitutions of the group. The paper outlines a method by which the position of the accessory points may be investigated, as well as the distribution of the roots of the various polynomials between the four (real) branch points and in the imaginary domain. One result is the determination of the distribution of the roots of all polynomials satisfying differential equations of the second order with exactly four branch points which with their exponent differences are given.

Mr. Roberts' paper gives the differential equations of certain systems of conics in a

plane, viz., conics having double contact with two fixed conics, etc., and in space, of conics touching six fixed planes, conics having double contact with three quadrics inscribed in the same developable, circles having double contact with two confocal quadrics, etc. These results are principally deduced by means of elliptic integrals and the first-class of hyper-elliptic integrals, and from them flow certain theorems concerning doubly infinite porisms of curvilinear polygons. This paper will be published in the *Bulletin of the American Mathematical Society*.

Professor Taber's paper related to the orthogonal transformations which leave a bilinear form unaltered, and their generation by means of infinitesimal transformations. It has been contributed to the *Quarterly Journal of Pure and Applied Mathematics*.

In Professor Hathaway's paper the proof consists in identifying, by means of elementary geometry, the product of several versors with the composition of a set of rotations through angles double those of the corresponding versors. The obvious associative principle of the composition of the rotations proves the corresponding associative principle of multiplication of versors. This paper will appear in the *Bulletin of the American Mathematical Society*. It was presented to the Society by Professor Shaw.

Professor Maschke's paper contains a very elegant application of elliptic functions to curves drawn on the surface of a circular ring. This paper will also appear in the *Bulletin of the American Mathematical Society*. It was presented to the Society by Professor Morley.

At the afternoon session, August 28th, two topics were presented to the Society for general discussion:

(1) 'A general subject catalogue or index of mathematical literature.'

(2) 'The mathematical curriculum of the college and scientific school.'

The first discussion was opened by the

Secretary, who gave a brief account of the '*Répertoire bibliographique des sciences mathématiques*,' in course of publication by the Mathematical Society of France. The discussion was continued by Professors Morley, Woodward and McMahon. On motion by Professor McMahon, it was resolved that the Council be requested to consider the desirability of offering to the Mathematical Society of France the coöperation of this Society and of drawing up a plan for such coöperation.

The second discussion was opened by Professor Shaw, who presented a table of statistics showing the character of the mathematical instruction in 101 representative colleges and scientific schools. The discussion was continued by Professors White, Morley, Van Vleck, Doolittle, Chandler, Pupin and Woodward. It seemed to be generally held that the work of the preparatory schools as a whole is not sufficiently thorough to serve as a satisfactory basis for collegiate courses; that a greater proportion of the students' time should be given to mathematical study; that greater stress should be laid on the fundamental subjects; that elementary portions of applied mathematics should be earlier introduced and more extensively taught, and that spherical trigonometry should be in great part, or altogether, dropped from the required curriculum.

At the close of the discussion the thanks of the Society were tendered to the Springfield Local Committee for the accommodations and hospitality which the Society had enjoyed, and the meeting was adjourned.

THOMAS S. FISKE.

COLUMBIA COLLEGE.

THE SPRINGFIELD MEETING OF THE AMERICAN ASSOCIATION FOR THE ADVANCEMENT OF SCIENCE.

SECTION A. MATHEMATICS AND ASTRONOMY.

In section A, Mathematics and Astronomy, the following papers were read :

1. *Development of Some Useful Quaternion Expressions, with Applications to Geometry of Three and Four Dimensions*: JAMES BYRNE SHAW.
2. *The Constant of Aberration*: C. L. DOOLITTLE.
3. *On the Constant of Nutation*: S. C. CHANDLER.
4. *Progress of the Zone Work at the Naval Observatory, Washington*: A. N. SKINNER.
5. *On the Distribution and the Secular Variation of Terrestrial Magnetism* (read by title): L. A. BAUER.
6. *Sun Spots and Magnetic Storms*: M. A. VEEDER.
7. *The Spectrum of B. Lyrae*: EDWIN B. FROST.
8. *Notes on Square Numbers Whose Sum Is Either a Square or the Sum of Other Squares*: ARTEMAS MARTIN.
9. *Some Results for Stellar Parallax from Meridian Transit Observations at the Washburn Observatory*: ALBERT S. FLINT.
10. *A Convenient Formula for Computing Times of Moon Rising*: EDGAR FRISBY.
11. *On a Slide Scale for Computing Precession*: EDGAR FRISBY.
12. *Chronology and Ancient Eclipses*: SAMUEL W. BALCH.
13. *Period of R. Comae*: HENRY PARKHURST.

In his paper Professor Shaw develops the alternating functions, $A.pq = \frac{1}{2}(pq - qp,$

$$S.p Aqr$$

$$A.pqr = S.p Aqr - Sp. A. qr,$$

$$-Sq. Arp - Sr. Apr,$$

$$S.p Aqrs.$$

A set of four quaternions related to one another is deduced, analogous to a set of three rectangular unit vectors and from which various collections of formulas can be derived.

Affixing one of the set of four quaternions to each vertex of a tetrahedron and letting the point $P = x_1 l_1 + x_2 l_2 + x_3 l_3 + x_4 l_4$ be that point for which the volumes $BC, P - BCD, P - CDA, P - DAB, P - ABC$ are as $x_1 : x_2 : x_3 : x_4$ we are enabled to treat solid geometry projectively.

The elaborate and carefully arranged series of observations made by Professor C. L. Doolittle at Lehigh University, primarily for the determination of the variation of latitude, was planned by him so that a determination of the constant of aberration could also be secured, stars being taken

throughout all the 24 hours, and the pairs being observed before and after midnight so as to obtain maximum aberration coefficients, with opposite sign. This series was observed from 1892, October 10, to 1893, December 27, 442 nights.

Professor Doolittle finds for the constant of aberration

$$20.''55,$$

Struve's value being $20.''44$. Later values differ considerably from that of Struve, and it would appear that his value is too small.

Dr. Chandler, on examining Pond's Greenwich mural circle observations with the idea of getting at the long period term of the variation of latitude, found the work to be of excellent quality, quite as good as the modern work, though imperfectly reduced. The plan of observation was first-rate, being so arranged as to eliminate as far as possible division errors, flexure and all instrumental constants. Indeed, Dr. Chandler regards the discovery of the good quality of this work as a most important one. From Pond's observations is found for the constant of lunar nutation

$$9.''190,$$

the usual value, called Peters', being

$$9.''223.$$

Peters observed only a few stars and took no account of the long period variation of latitude. It is probable that the constant of lunar nutation is very nearly

$$9.''20,$$

since Professor Newcomb finds for this constant from the Greenwich transit circle declinations and the Washington transit circle declinations respectively

$$9.''194,$$

$$9.''204.$$

It should be noted that Dr. Chandler's discussion of Pond's mural circle declinations confirms Boss' proper motions as being almost exact.

A number of years ago the German Astronomical Society inaugurated the plan of making fairly accurate determinations of the stars in the Durchmusterung of Arge-lander and that of Schönfeld. The sky was divided into bands or zones, every zone overlapping for comparison purposes on the zones north and south.

Mr. Skinner gave an account of the work on the zone — $13^{\circ} 50'$ to — $18^{\circ} 10'$ which had been assigned to the Naval Observatory, and which is now being observed there under his charge. Zero stars are distributed throughout the zone, the other stars being determined differentially with respect to them. Each star is to be determined at least twice. The work has now been going on for a year and a half. The zone has been observed in one position of the instrument, and 5,714 stars in the reversed position, the whole number of stars being more than 8,000. Probably the observing will be completed next winter and it will be about two years after that before the reductions are finished.

Dr. Veeder is doing excellent work collecting statistics with regard to auroras, magnetic storms and thunder storms, and endeavoring to derive general laws. It is to be hoped that many observers may be found who will furnish him the data he desires.

The problems regarding the spectrum of β Lyrae as brought to light by recent spectroscopic observations of this star at Pulkova, Potsdam and London were treated by Professor Frost.

Mr. A. S. Flint, of the Washburn observatory, presented some results of the researches with regard to stellar parallax undertaken by him with the Repsold meridian circle of that observatory by the method of Kapteyn. A list was made of stars having a proper motion of $1''$ or more. A large number of these stars Mr. Flint has observed for three epochs, and he proposes to continue until he shall secure five. As to the

method of observing a bright field was used and wire screens were employed so that all stars should appear in the telescope as approximately of the same brightness. The observations were begun 1893, October. The method of Kapteyn, which is differential, employing a preceding and following comparison star, is certainly excellent. Mr. Flint has obtained important results of a high order of accuracy.

ASAPH HALL, JR.

SECTION E. GEOLOGY AND GEOGRAPHY.

EIGHTEEN papers were presented to the section this year, but only thirteen were read in full, as the authors of the others were not present at the meeting. Major Jed. Hotchkiss, of Staunton, Va., the Vice-President, was absent from the early sessions of the section, so that his address was not delivered until Monday afternoon. He then gave a somewhat informal talk on the geological survey of Virginia, 1835-1841, and its influence on the history of science in this country. This survey was conducted by Professors W. B. and H. D. Rogers and was held by the speaker to have been the first important geological survey carried on in the United States. The work was carried on for five years at an expense of only \$100,000 and the results lie at the foundation of the progress made in geology since.

'The relations of primary and secondary structures in rocks' was the topic discussed by Professor C. R. Van Hise, of Madison, Wis. The paper inquired into the relations of cleavage and fissility to bedding, and showed that in homogeneous rocks the law of hydrostatic viscous flow applies, and therefore that the secondary structure cuts the primary. In heterogeneous rocks the beds are of varying strength, and the accommodations between them control the major movements, which are parallel to them. The secondary structure is produced

by shearing and is therefore parallel to the bedding, and this may be called parallel cleavage or parallel fissility. In heterogeneous rocks, however, at the crests and troughs the law of hydrostatic flow chiefly applies, while the law of shearing applies at the limbs. In passing from the limbs of the folds to the arches and troughs the two tendencies are both at work, and the phenomena are the resultants of both forces. The law of hydrostatic viscous flow becomes predominant as the arch or trough is neared; the law of shearing, as the limb is approached.

Professor B. K. Emerson, Amherst, Mass., delivered the substance of two papers on the Archaean and Cambrian rocks of the Green Mountain range in southern Massachusetts and on the geology of Worcester County, Mass., which embodied a preliminary account of the author's work on the region for the United States Geological Survey. The Green Mountains traverse western Massachusetts in a series of complex anticlines and synclines which are partly overturned and overthrust westward. Upon these in places there is unconformable conglomerate gneiss of Cambrian age. The author illustrated by means of the United States Geological Survey topographic maps the progress of the work in mapping the intricate crystalline rocks in the district.

'Gotham's Cave, or Fractured Rocks in Northern Vermont' was the title of a short paper by Professor C. H. Hitchcock, N. H., describing with the aid of sketch maps and sections a peculiar occurrence in the Green Mountain State.

'Recent discovery of the occurrence of marine cretaceous strata on Long Island.' In this paper Mr. Arthur Hollick, of Columbia College, said that the presence on Long Island of cretaceous strata belonging to the so-called non-marine division was amply demonstrated some years ago, but until the past year the evidence of the ex-

istence there of marine strata of this age was confined almost entirely to the alleged discovery of an *Ecogyra* in an excavation for a well in Brooklyn. Last summer, while examining the north shore at Center Island, evidences of more strata were observed, and afterwards hardened fragments of marl containing *Gryphæa* and other cretaceous molluscs were found in the moraine near Ridgewood Reservoir, Brooklyn.

Dr. J. W. Spencer read a contribution on the 'Geological Canals between the Atlantic and Pacific Oceans.' He said that over the Isthmus of Tehuantepec, in Mexico, low planes now eroded mark a shallow strait of a few miles in width connecting the basin of the Mexican Gulf with that of the Pacific Ocean. This land is now raised about 1,000 feet above sea level. Through these straits there are two lower canals about 800 feet above tide, only a mile long and a quarter of a mile wide, whose floors are covered with gravels which are continuous with terraces upon the gulf side. The time of elevation is that of the recent terrace epoch; at any rate it was later than the Columbia period.

A second paper by Dr. Spencer dealt with the 'Recent Elevation of New England.' He holds that the high terraces in the valleys of New England are not those of rivers but of estuaries. These terraces occur on the north, east, south and west sides of the New England rivers from an elevation of at least 2,700 feet downward by level steps. From their features it is inferred that these steps represent changes in the base plane of erosion, or, in other words, successive uplifts in the most recent post-glacial times in amount approximately equal to the aggregate heights of the terraces. The elevation appears to have been greater in the mountain masses than nearer the sea.

'Geological Notes on the Isles of Shoals,' by Dr. H. C. Hovey, Newburyport, Mass. The author briefly described these islands,

which lie off the coast of Maine and New Hampshire. Statements made by reliable residents seem to show that some of the islands have risen six feet in the last fifty years, while the rest seem to be stationary. The general rock is gneissoid to schistose and varies in color from white to black. The islands are traversed by numerous dykes of basic rock. On Appledore Island there is a peculiar six-sided column of granitoid rock protruding through a schistose, biotite gneiss. The column is more than eleven feet in diameter and its original height must have been from 25 to 50 feet.

'The Great Falls of the Mohawk at Cohoes, N. Y.,' by W. H. C. Pynchon, Trinity College, Hartford, Conn. This paper described, by the aid of maps and stereopticon views, the gorge of the Mohawk and the falls. The author brought out the fact that the rocks, which are Hudson river shales, dip sharply down stream instead of up stream as is the case at many falls, notably Niagara. The gorge is shown to be a post-glacial cutting and the old valley still exists not far from the present one. The position of the strata facilitates the formation of innumerable pot holes of all sizes up to ten feet in diameter.

In a paper entitled 'Subdivisions of the Upper Silurian in Northeastern Iowa,' A. G. Wilson, of Hopkinton, Ia., gave lithological and palaeontological characteristics on which he would propose to divide the Niagara strata there into five groups:

5. The building stone.
4. The upper coralline beds.
3. The Pentamerus beds.
2. The lower coralline beds.
1. The beds of passage from the Maquoketa shales.

Professor J. P. Smith, Stanford University, California, in a paper on the metamorphic series of the Shasta region of California, supplemented observations which the author detailed to the section at the

Brooklyn meeting. New finds in the Middle Trias shales make the age assigned to them more probable; certain strata which are of Upper Trias combine in the same beds fossils which are always in separate beds in the Alps and Himalayas. The discovery of an upper Karnic, or more probably Jurassic, fauna was announced.

In the absence of the author, Mr. Warren Upham's paper on a 'View of the Ice Age as Two Epochs, the Glacial and the Champlain,' was read in abstract at the request of some members of the section. The author divides the Glacial epoch of ice accumulation into four stages: 1, Culmination of the Lafayette epirogenic uplift; 2, the Kansan stage, marking the farthest extent of the ice sheet; 3, the Helvetian or Aftonian stage, during which there was considerable recession of the ice-front; 4, the Iowan stage of renewed ice accumulation. The Champlain epoch of ice departure is divided into four more stages continuing the others: 5, the Champlain subsidence or Neudeckian stage—a time of widespread depression; 6, the Wisconsin stage—marked by moderate re-elevation of the land; 7, the Warren stage, of maximum extent of glacial Lake Warren, and 8, the Toronto stage, with slight glacial oscillations, but temperate climate at Toronto and Scarboro, Ontario.

'A re-survey of the whirlpool and vicinity of the Niagara river, with a demonstration of the true geology of the locality, illustrated by a new, large map.' In this paper Mr. George W. Holley presented some views regarding the origin and history of the gorge of the Niagara which were considerably at variance with those commonly accepted by geologists.

'Glacial phenomena between Lake Champlain, Lake George and the Hudson' was the title of a paper by Professor G. F. Wright, of Oberlin, Ohio, in which the author detailed the results of recent personal study of that region. He described the mo-

rainic lakes which existed at two or three points along the southern shore of Lake George and the end of Lake Champlain, the drainage of Lake George in both directions after the ice had left its basin, and the elevated gravel and sand terrace near Saratoga.

In a somewhat informal lecture Professor H. L. Fairchild, Rochester, N. Y., described some interesting features in the surface geology of the Genesee region, New York. The lecture was illustrated by numerous lantern slides, some of which were especially instructive as showing in an excellent manner the intimate structure of the gravel and sand beds. These are glacial till as well as stratified lacustrine deposits.

The papers read only by title were:

Terminology proposed for the description of the shell in Pelecypoda: by Professor A. Hyatt, Boston, Mass.

Russia in Europe: by Dr. Gardiner G. Hubbard, Washington, D. C.

Distribution of sharks in the Cretaceous: by C. R. Eastman, Cambridge, Mass.

The equatorial counter currents: by Professor W. M. Davis, Cambridge, Mass.

On Saturday, 31st August, the section joined in the general excursion to Amherst, Northampton and South Hadley. The interest for the section centered in Amherst, of course, and there, under the guidance of Professor B. K. Emerson, the members studied the famous collection of footprints and other impressions from the Connecticut trias made by President E. Hitchcock. These remain in the Appleton Cabinet just as they were left by President Hitchcock. In another building are the fine collections of minerals and rocks which have been gotten together by Professor Emerson since the fire occurred which destroyed the College collections some years ago.

Tuesday nine or ten members of the section availed themselves of the opportunity

offered to accompany Professor W. M. Davis to the region of trap and sandstone near Meriden, Conn., which he has studied so thoroughly, from which he has described overflow sheets of trap, beds of tuff with ejected blocks and extensive faults.

EDMUND OTIS HOVEY.

SECTION G. BOTANY.

The botanists were well represented at the recent meeting of the American Association for the Advancement of Science, held at Springfield, Mass. Interesting papers were presented at the meetings of the Botanical Society of America and the Botanical Club. In addition to these Affiliated Societies, Section G (Botany), of the Association proper, also had a full program.

The address of the Vice-President, Dr. J. C. Arthur, was delivered on Thursday afternoon, August 29, the subject being 'The Progress of Vegetable Physiology.' As the address appeared in full in SCIENCE, September 20th, it is not necessary to review it here. The papers read before Section G are briefly reviewed below:

1. *A Leaf Rot of Cabbage*, by H. L. RUSSELL, Madison, Wis. In the absence of the author this paper was read by Professor Barnes, of the University of Wisconsin. The disease seems to be associated with bacteria, although the author has not succeeded in isolating the organism. The axils of the lower leaves first show the disease. These points are usually filled with moisture, and the disease gains an entrance through rents caused by rapid growth of the tissue. Once within the tissues, the disease spreads rapidly through the fibro-vascular bundles; as a result, the functions of the plant are disturbed and the leaves wilt. The disease seems to be different from the one described by Garman, and may be checked by cutting off the affected leaves along the main stalk.

2. *Watermelon Wilt and other Wilt Dis-*

eases Due to Fusarium, by ERWIN F. SMITH, Washington, D. C. The author reviewed the work of last year and gave the results of investigations confirming previous statements regarding the nature and cause of watermelon wilt. The discovery of two additional stages of the wilt fungus were noted, and evidence was brought forward to show the great vitality of the fungus. Wilt diseases caused by *Fusarium* have been recently found in a number of other plants, notably sweet potato, cabbage, and cowpeas. On the last-mentioned plant a new *Nectriella* was found, and the evidence shows that the conidia so abundant outside and inside of the plant are but forms of this Ascomycete.

3. *Observations on the Development of Uncinula spiralis* B. & C., by B. T. Galloway, Washington, D. C. The author first called attention to a paper presented before the Association in 1890, in which it was shown by artificial cultures that the forms of *Uncinula spiralis* found on *Vitis* and *Ampelopsis* are identical. The development of the fungus was then discussed, especial attention being called to the manner in which the parasite passes the winter. It was shown that the first material change in the fungus after the leaves have fallen is the disappearance of the perithecial appendages. Observations made from time to time brought out the fact that there was no germination of ascospores before January. Through the months of January and February the ascospores were successfully germinated by keeping perithecia, which had been, out all winter, for several weeks in moist chambers. The asci were ejected from the perithecia with considerable force, and in most cases collapsed as soon as free. Only a comparatively small number of asci and ascospores remained perfect, and such of the latter as did not break up commenced to germinate within four or five hours after their escape from the ascus. Attempts were made to obtain the fungus on *Vitis* and

Ampelopsis by sowing ascospores, but this work was wholly negative.

4. *The Effect of Sudden Changes of Turgor and of Temperature on Growth*, by RODNEY H. TRUE, Madison, Wis. In the absence of the author, this paper also was read by Prof. Barnes. The author claims that growth and turgor pressure have no direct proportional relation, and in proof of this shows the variation in growth when a radicle is suddenly transferred from water to a one per cent. solution of KNO_3 or *vice versa*, or when it is accommodated to these media by a stay of two or three days before the transfer is made. He attributes retardation to the irritable qualities of the plant, and in substantiation of this discusses the fact that when change of medium produces a very material increase of turgor pressure the rate of growth usual for both media mentioned falls below the normal. He found changes of temperature to affect growth in about the same way as changes of turgor, the retardation period in this case depending upon length of time between extremes and length of time spent at the lower limit when the plant is transferred to a normal range. The author's conclusion is that sudden changes in turgor pressure or surrounding temperature act as a shock to the irritable organisms and cause a pronounced retardation of growth.

5. *Recording Apparatus for the Study of Transpiration of Plants*, by ALBERT F. WOODS, Washington, D. C. Attention was first called by the author to the fact that the direct method of weighing the plant is the most satisfactory one of determining the amount of water evaporated during a given period. Various automatic devices for accomplishing this object have been described and used. The apparatus in question is a modification of Marvin's recording rain and snow gauge, and is designed to register automatically the loss of water through any given period. It is constructed so as to

register a tenth of a gram. This amount can be reduced to smaller quantities by subdividing the curve recorded.

6. *Pressure, Normal Work, and Surplus Energy in Growing Plants*, by GEORGE M. HOLFERTY, Leipzig, Germany. This paper was read by Professor Barnes in the absence of the author. The general questions of pressure, interior and exterior; resistance, natural and artificial; work effects, normal and extra, were discussed. Pfeffer's results showing the amount of pressure were given, and the gypsum method and pressure spring for root pressure were described.

7. *Notes on the Ninth Edition of the London Catalogue of British Plants*, by N. L. BRITTON, Columbia College, New York City. The author gave a comparison of the treatment and nomenclature of genera in the catalogue common to Great Britain and north-eastern North America.

8. *Obolaria virginica L., a Morphological and Anatomical Study*, by THEODORE HOLM, Washington, D. C. The systematic position of *Obolaria virginica* L. was reviewed, the statements being based upon the morphological characteristics and the anatomy of the various organs of the plant.

9. *Botany of Yakutat Bay, Alaska*, by FREDERICK V. COVILLE, Washington, D. C. This paper was a review of a report upon a collection of plants made at Yakutat Bay, Alaska, by Mr. Frederick Funston in 1892. Attention was called to the more important plants collected and a general account was given of the relation of the plant life of the region to environmental conditions and native industries.

The foregoing papers completed the program for Friday. Saturday being devoted to general excursions no regular meetings were held. On Monday Section F (Zoölogy) and Section G (Botany) met in joint session with the following program:

10. *Fungous Gardens in the Nest of an Ant (Atta tardigrada Buckl.) near Washington, D.*

C., by W. T. SWINGLE, Washington, D. C. The author first briefly reviewed the published statements by Belt made in 1874, that the Central American leaf-cutting ants use the cut-up leaves for carrying into their nests as a medium upon which to grow fungi which serve as food for the ants. The important work of Möller on the fungous gardens of ants in south Brazil, published in 1893, was then reviewed. Möller showed that the ants not only cultivate a fungus on chewed-up fragments of leaves, but that they also make pure cultures of a single species, and furthermore, that they prevent the fungus from producing conidia or other reproductive bodies. The fungus under the action of the ants gives rise to globular inflated hypha ends, which are incapable of germinating and which Möller designated as kohlrabis. In July of this year the author examined some colonies of *Atta tardigrada* in the vicinity of Washington, and found within the nests a fungus closely resembling that described by Möller. Kohlrabis even larger and more perfect than those described by Möller were found, and from this and other evidence the author thinks that it is by no means improbable that the species will prove to be the same as that described by Möller.

11. *Distinction between Animals and Plants*, by J. C. ARTHUR, La Fayette, Ind. The author called attention to the present and former use of physiological characters to distinguish plants and animals, and to the insufficiency of such characters to explain the differences under consideration. The following was suggested as expressing the difference between animals and plants: "Plants are organisms possessing in their vegetative state a cellulose investment; animals are organisms possessing in their vegetative state a proteid investment, actual or potential."

12. *Variation after Birth*, by L. H. BAILEY, Ithaca, New York. The author

reviewed the current discussion of causes of variation and showed that they are concerned chiefly with those forms which are congenital. Argument was then advanced to show that a given set of individuals starting equal may arrive at very unlike destinies. These dissimilarities may be impressed upon the offspring.

13. *Rejuvenation and Heredity*, by CHAS. S. MINOT. The author traced the rôle of the embryonic type of cells in animals and plants as a necessary predisposition of structure for the action of heredity. The rôle of the embryonic type of cells in both animals and plants in reproduction and regeneration was discussed for the purpose of showing that their functions render it impossible to accept Weissman's theory of heredity.

At the close of the last paper the joint session ended. On the afternoon of Monday the final papers before Section G were presented. These are given below:

14. *Poisoning by Broad-leaved Laurel* (*Kalmia latifolia*), by FREDERICK V. COVILLE, Washington, D. C. Read by title.

15. *The Number of Spore Mother Cells in the Sporangia of Ferns*, by WILLIS L. JEPSON, Berkeley, Cal. This paper was presented by Prof. Geo. F. Atkinson, and gave the details of investigations to determine the number of spore mother cells in the sporangia of *Pteris crethea*, with comparisons of other species of *Pteridophyta*.

16. *The Southern Tomato Blight*, by ERWIN F. SMITH, Washington, D. C. The author reviewed his previous work on this subject, and from the evidence obtained concludes that the tomato wilt and cucumber wilt are not identical; that the tomato and potato wilt are identical; that various other solanaceous plants, including eggplant, are susceptible to the disease; that the cause of the disease, as determined by inoculations, is a bacillus, the biology of which has not been fully worked out; that the stinking wet rot

is due apparently to one or more organisms which follow in the path of the true parasite; and finally, that primary infection of the plants as a rule takes place through the parts above ground.

17. *Constancy of the Bacterial Flora of Fore Milk*, by H. L. BOLLEY, Fargo, N. Dak. This paper was a report of investigations on the constancy of species and physiological types of bacteria in normal fore milk. The experiment was conducted with ten animals during three winter months and three animals during the month of July. The conclusion drawn by the author is that species may be quite constant in the udder of an individual animal, but that there is little evidence of constancy among different animals, even under similar conditions.

18. *A New California Liverwort*, by DOUGLAS H. CAMPBELL, Palo Alto, Cal. The author gave a brief account of a new liverwort allied to *Spheroacarpus*, collected near San Diego, Cal.

19. *Personal Nomenclature in the Myxomycetes*, by O. F. COOK, Huntington, N. Y. The author claims that only the personal system of nomenclature is used in the Myxomycetes, naming Masee's Myxogastres and Lister's Mycetozoa in substantiation of the claim. The paper discusses the author's view of the changes which will be necessary should the priority system of nomenclature be adopted.

20. *Root Fungus of Maize: Enantiomorphism in Plants*, by GEO. MACLOSIE, Princeton, N. J. The root cap of the roots of maize is described. The author believes that the nature of the cap makes it a medium for the luxuriant growth of a certain microscopic fungus, and that this fungus may possibly account for the ability of Gramineæ to extract nitrogenous food without impoverishing the soil. The author claims to have discovered two kinds of maize produced from the same ear, and states that this diversity depends on place of origin of

the ovules. This habit the author calls antidromy, and claims that all flowering plants are antidromous. The manner in which this habit manifests itself in different plants is described and a list of the plants examined is given. The author thinks this law will explain many of the mysteries of plant growth.

21. *Exoascus upon Alnus Leaves*, by MRS. FLORA W. PATTERSON, Cambridge, Mass. An account is given of the first recorded appearance of *Exoascus* on *Alnus* leaves in America. The difference between this *Exoascus* and various other species is shown. The species will not be named until additional knowledge in regard to it is obtained.

22. *Experiments in Pollinating and Hybridizing Citrus Fruits*, by H. J. WEBBER, Eustis, Fla. The author gives an account of his experiments to determine the cause of the sterility of the Navel orange. It was found that this variety produces no pollen. The form, growth, etc., of the Navel and common oranges are minutely described. Experiments were also conducted by the author to determine if Navel oranges develop without pollination and the effect on this variety of foreign pollen. Other experiments in hybridizing were also described.

23. *Summary of a Revision of the Genus Dieranum*, by CHAS. R. BARNES and RODNEY H. TRUE, Madison, Wis. Read by title.

24. *The Physiology of Isopyrum vibernatum L., and the Transmission of Stimuli Effects in Mimosa pudica L.*, by D. T. MACDOUGAL, University of Minnesota. The papers by Professor MacDougal were read during the absence of the Secretary, and as the abstracts were not at hand a review cannot be given.

On Saturday, August 30, a number of the botanists visited Harvard College, where they were entertained by Dr. Farlow, and shown the many things of botanical interest in the vicinity of Cambridge.

B. T. GALLOWAY, Secretary.

SECTION I. ECONOMICS.

THE most important feature of the meeting was the change in name of the section, looking toward an extension of scope. The old name 'Economic Science and Statistics' was justly regarded as bungling and inadequate. The question of terminology is, however, a serious one. No name wholly adequate to express and limit the field which this section seeks to cover could be found. It is properly a branch or offshot of anthropology, as Mr. Fernow showed in his Vice-Presidential address, and is concerned with all that advances the physical well-being of man; while, equally with anthropology, it discusses his social and moral welfare, all being indissolubly knit together. 'Sociology' was at first the name selected by the section, after considering 'Social and Economic Science.' The general session, however, preferred the latter, and the constitution was accordingly so amended.

The Section of 'Social and Economic Science' is fortunate in having had as its President this year an economist so well and favorably known as B. E. Fernow, Chief of the Division of Forestry; and equally fortunate in the election for next year of Wm. R. Lazenby, so long a professor at the Agricultural College at Columbus, O., and this year doubly honored by election to the office of President of the Society for the Promotion of Agricultural Science.

Popular interest in this section is always great, and even when there is not a flood of papers there are always some to arrest attention. Not that everything said in the section is sound. Some wild monetary theories have been broached; some revolutionary socialistic schemes advocated, but the sound common sense of the majority of members gives them a speedy quietus, and the result is better than if they were exploited somewhere else where their fallacy might be less promptly refuted. On the other hand, some interesting and valuable

material is almost certain to be presented among the papers read and in the discussions.

Papers were read by title in the section on 'The Law of Chance Illustrated in Railway Accidents,' by T. C. Mendenhall, and on 'Suicide,' by W. L. O'Neill. On the morning of Friday, August 30, Mr. Henry Farquhar read a paper on 'An International Coinage,' which contained arguments for such a system and reviewed the difficulties to be overcome before the system could be put in practical operation.

In the afternoon a joint session of Sections A, B, E and I was held to listen to papers on meteorology, which will be reported elsewhere in this journal.

On Monday, September 2, the first paper presented was by the Secretary of the Section, W. R. Lazenby, whose subject was 'Manual Training in Horticulture for Our Country Schools.' The author said that in the earlier educational history of this country, when the forests covered large sections of the land and people lived in log houses built by their own hands, and the school-houses were constructed in the same manner, the boys and girls grew to be men and women of great force of character and strong personality. Nothing could be more useful than manual training in horticulture to train the eye and hand, to stimulate the power of observation, to awaken an appreciation of the beautiful, in short to develop all the faculties of body and mind, which is the aim of modern education. In a paper entitled, 'Equality of Opportunity—How Can We Secure It?' J. L. Cowles argued in favor of government control of the means of communication and transportation. Mrs. Mary J. Eastman, an associate member, was invited to read a paper on 'A Cottage Settlement in Spain,' in which she advocated the extension of the university settlement idea by the establishment of model cottages.

On Tuesday, September 3, E. L. Corthell read a paper on 'The Growth of Great Cities.' He traced the growth of cities, and closed by predicting the population of some of the world's greatest cities in 1920, as based on past and present growth, and allowing for a future decrease. His predictions are as follows: Population of London 8,344,000; Paris, 3,808,586; New York, 6,337,500; Berlin, 3,422,221; Chicago, 7,797,600; Philadelphia, 1,838,160; St. Petersburg, 1,470,833. The last paper of the meeting was on 'Taxation in the United States,' by Edward Atkinson. The speaker aimed to show the necessity of carefully investigating what proportion of taxes goes to construction, to interest, etc. Other things being equal, the country that spends the most of its taxes for construction and the least for military expenses is the best administered.

SCIENTIFIC NOTES AND NEWS.

M. CH. BOUCHARD announced to the Paris Academy of Sciences, on September 2d, that he had examined the gases from three sulphurous springs in the Pyrenees. In one he found the characteristic lines of both argon and helium, in one of helium alone, and in a third helium together with an unknown substance characterized by lines in the orange and red.

At the same meeting of the Academy, M. J. Janssen reported on the work at Mont Blanc Observatory. Measurements of the force of gravity have been made at Chamoniix and at the Grand-Mulets, at an elevation of 3,050 m., and it is hoped to repeat the measurements next year at the summit, if it be found possible to transport the apparatus. M. de Thierry has ascended to the summit in order to study the ozone in the air and make certain bacteriological examinations.

PROFESSOR C. V. RILEY, the entomologist, was killed by a fall from a bicycle at Wash-

ington on September 14th. We hope to give an account of Professor Riley's scientific work in an early number of this journal.

PROFESSOR E. D. COPE's important work, previously announced in this journal, will be published in October by the Open Court Publishing Company. It will be entitled *The Primary Factors of Organic Evolution*. The same publishers announce *Post-Darwinian Questions*, the second part of the late Prof. George J. Romanes's work *Darwin, and After Darwin*. With the exception of the concluding chapters, the present volume was ready for publication over two years ago, but the severe and protracted illness of Professor Romanes prevented its speedy completion. On his death, in 1894, the manuscript was placed in the hands of his friend, Prof. C. Lloyd Morgan, Principal of University College, Bristol, England, who has edited the work.

THE autobiography of Mr. Herbert Spencer is already in print, though it will not be issued till after his death.

THE Naturforschende Gesellschaft of Switzerland met at Zermatt from September 8th to 11th, and The Swiss Geographical Societies at St. Gall on September 22d and 23d.

Nature states that a memorial tablet in honor of v. Helmholtz has been affixed to the house No. 8 Haditz Strasse, Potsdam, in which he was born, and also that it is intended to erect a joint monument to the memory of Werner Siemens and v. Helmholtz in front of the Technische Hochschule at Charlottenberg.

WE have received No. 62 of the *Monthly Weather Review*, containing the annual summary for 1894. Tables and charts are given showing barometer readings, temperature, precipitation and other meteorological phenomena throughout the United States.

THE English record in railway speed

made by a run from London to Aberdeen over the London & Northwestern Railway of 540 miles in 512 minutes has been surpassed by a run on the New York Central & Hudson River Railroad on September 11th. The train ran from New York to Buffalo, a distance of 436½ miles in 407 minutes. This is an average of 64½ miles an hour as compared with the English record of 63½ miles an hour. The train on the New York Central & Hudson River Railroad was also much the heavier.

At a recent meeting of the Park Board, New York, eight bids ranging from \$319,000 to \$444,000 were received from various builders and contractors for the completion and enlargement of the new west wing of the American Museum of Natural History. The awards will probably be made in a few days.

THE *British Medical Journal* states that a quarterly court of the governors of the London Hospital was held on September 4th, Mr. J. H. Buxton, the Treasurer, presiding. In the report the House Committee stated that the amount subscribed to the Sir Andrew Clark Memorial Fund was close upon £3,000, and it had been determined to recommend the governors to adopt a scheme for the building of a female erysipelas ward and accommodation for cases needing isolation, and additional rooms for the porters. To carry that scheme into effect a further expenditure of £1,500 would be necessary, and the Board asked the governors to sanction that step.

THE Prince of Wales has accepted the presidency of the committee of the Huxley Memorial. The general committee will probably hold its first meeting some time in October.

THE Orient Steam Navigation Company, Ltd., propose to send one of their steamships of about 4,000 tons gross register and 3,000 H.P. to Vadsø in the Varanger Fiord,

Lapland (about 30° E. Long.), to enable observation to be made of the total eclipse of the sun on August 9th, 1896. The steamship starts on July 21st and is due at London on the return voyage on August 17th. The passage money is forty guineas.

It is stated that 2,000 deaths from cholera are occurring daily in Pekin. Cholera is also raging in the Russian Government of Volhynia, where the deaths are said to be about 250 a day.

ACCORDING to the *Naturwissenschaftliche Rundschau* Prof. Ernst Beyrich of Berlin has been presented with the gold 'Cothenius Medaille' by the Leopoldinisch-Carolinische deutsche Akademie der Naturforscher.

WALTER SCOTT has published *The Growth of the Brain*, by Prof. H. H. Donaldson, of the University of Chicago, as the latest volume of the Contemporary Science Series. The work will doubtless be shortly published in America by Chas. Scribner's Sons.

AN international industrial exhibition will be held at Cape Town, under the auspices of the Chamber of Commerce. The exhibition will open on November 18th and will continue for six weeks.

GINN & Co. announce a text-book on the *Elements of Plant Anatomy*, by Emily L. Gregory, of Barnard College. The book is divided into two parts, the plant cell and cell aggregates or tissues.

ACCORDING to the report of the Chief of the U. S. Weather Bureau for 1893 the total number of deaths in the United States caused by violent winds was 399, and the number of deaths caused by lightning was 209. In 1892 the deaths caused by violent wind and lightning were nearly the same, 252 and 251 respectively.

THE meeting of the German Association for the Repression of the Abuse of Alcoholic Drinks will be held this year at Munich on

September 18th and 19th. Among the papers to be presented are 'Hygiene and Temperance' by Professors Hans Buchner and Max von Pettenkofer; and 'Beer and the Alcohol Question' by Professor Moritz, of Munich.

ACCORDING to the London *Times* 320 cases of small-pox were under treatment within the metropolitan area on September 12th.

THE International Congress of Physiology opened at Berne on September 9th. Some 80 papers were on the program.

MR. H. TWEDELL, a distinguished English engineer, died on August 23d.

M. JULES LAVERRIÈRE, a French writer on agriculture, died at Lyons at the beginning of the present month.

A TELEGRAM has been received from India by the relatives of Mr. Mummery, the famous Alpine climber, stating that he has been lost while climbing the Himalayas, and that his remains are being searched for.

THE deaths are reported on August 26th of Dr. Frederick Miescher and Dr. Ernst de Sury, professors of physiology and of legal medicine, respectively at Bâle, and of Dr. Moritz Willkomm, professor of botany in the German University at Prague.

UNIVERSITY AND EDUCATIONAL NEWS.

THE faculty of Harvard University has sent to the corporation a proposition to establish 'docents' similar to those in the German universities. The men thus designated would be holders of the degree of Ph. D: who might offer advanced courses to graduate students without being paid for their work by the University.

MR. MELVIL DEWEY, Secretary of the University of the State of New York, has sent out a circular letter stating that Mr. Asa O. Gallup, who has so efficiently discharged the duties of chief clerk for the

past four years, will hereafter represent the University in New York city and will be as fully informed on all matters pertaining to this office as are the officers resident in Albany. He will have all publications, blanks and necessary records for the accommodation of law, medical, dental and veterinary students, and for all the professional, academic and higher examinations conducted by the University. The action of the last Legislature in largely increasing the preliminary and professional examinations under the regents has made a New York office a necessity. The office at 10 East 42d street will be open after September 10, 1895.

THE University of Illinois, at Champaign, opened on the 17th of September with one thousand students.

DR. WALTER M. RANKIN and Dr. Charles F. W. McClure have been appointed assistant professors of biology in Princeton College.

It is stated that Dr. Nathaniel Butler, of the University of Chicago, has decided to accept the presidency of Colby University.

DR. SAMUEL WEIR has been appointed professor of the history of education and ethics in the University of the City of New York.

It is proposed to open the new college buildings of the University of the City of New York on October 19th. Mayor Strong, Chancellor of the University of the State of New York, is invited to represent the Eastern colleges. A speaker to represent the colleges of the West and South will also be invited. It is announced that gifts amounting to between \$50,000 and \$60,000 have been received by the University during the summer.

HENRY B. KÜMMEL, Ph. D. (University of Chicago, 1895), has been appointed assistant geologist on the Geological Survey of New Jersey. His address is Trenton,

N. J., instead of the University of Chicago, as heretofore.

UNION COLLEGE began its one hundred and first year on September 19th. The Freshman Class numbers 100. Thirty candidates were refused admission owing to lack of room.

THE Freshman Class at Yale University numbers 350 as compared with 338 last year. Princeton College reports a slight increase in the academic departments and a marked decrease in the scientific departments.

THE University of St. Andrews is building a hall of residence for its women students on the lines of the Girton and Newnham Colleges at Cambridge and the Oxford Halls for Women. The fee for residence and board for the winter university session of six months will be £40, each student having a separate room. There will be 15 scholarships, all tenable for three years.

THE official returns of Swiss universities for the summer semester are reported in *The Lancet* of September 14th. 3108 students and 634 auditors attend the seven universities. Of these students 440 study theology, 648 law, 998 medicine, 1658 philosophy (science and literature). Of the 3108 students 1774 are Swiss, 504 German, 348 Russian, 131 Bulgarian, 56 French, 53 Austrian, 49 Roumanian, 39 Turkish, 39 Italian and 32 American. The greatest number of students attend the Universities of Zurich and Geneva, the attendance being 673 and 665 respectively.

DR. HERMAN CREDNER has been promoted to a full professorship of geology and paleontology at Leipzig, Dr. B. Weinstein to a professorship of physics at Berlin and Dr. Max Vervorn to an assistant professorship of physiology at Jena. Dr. Victor Eberhard, of Königsberg, has been called to fill the chair of mathematics at Halle.

CORRESPONDENCE.

ALLEGED SUPPRESSION OF DISCUSSION.

MR. ERWIN F. SMITH, of the United States Department of Agriculture, has printed a pamphlet on 'The Botanical Club Check List,' of which an abstract contributed by the author was published in the issue of SCIENCE of May 24th, pp. 587-8. In an introduction Mr. Smith writes:

"This paper was offered to the *Botanical Gazette*, passed through the hands of two of its editors, was accepted for publication and announced to appear in the June number. Subsequently it was rejected unless I would submit to have it cut down *two-thirds*. A much briefer statement of the case was previously accepted by SCIENCE, and proof sent to me, after which it was rejected as too long and too personal. Evidently every effort is being made to limit adverse criticism." * * *

An editorial article in the *Journal of Botany* (London) quotes and apparently endorses even more explicit charges of suppression of discussion. In answer to these charges the present writer sent the following letter:

"In the issue of the *Journal of Botany*, for July (p. 213) you quote from a correspondent who writes: 'The journals in question will not publish articles which give a true account of what has been said against the American system in Berlin and Vienna. A notice stating the facts was sent to SCIENCE and actually put in type, but the botanical editor suppressed it.' As you state, this is a serious charge, and I venture to ask you to insert this letter denying it. Your correspondent has been misinformed, as no article on the nomenclature question has been rejected by the botanical editor of SCIENCE. The only contribution presented to SCIENCE on this subject and not accepted was an account of an extemporary discussion (partly against and partly in favor of the proposed system) following the reading of a paper before the Biological Society of Washington. This discussion was considered by the undersigned not suitable in form for publication, but the speakers were invited to contribute a discussion of the subject to SCIENCE, and a paper by one of them, Mr. Erwin F. Smith, presenting views similar to those of your correspondent, was contributed by him

in abstract and printed in the issue of May 24th."

The *Journal of Botany* has printed this letter, excepting that the beginning has been altered so that the phrase 'as you state' may be omitted. The editor does not, however, withdraw the charges made in his journal.

In regard to the *Botanical Gazette* the editor of the *Journal of Botany* writes:

"We have received a similar communication, which we have unfortunately temporarily mislaid, from the editor of the *Botanical Gazette*, pointing out that articles opposing the neo-American nomenclature have appeared in that journal, and stating that the paper on the subject referred to in the extract we printed was rejected by him on grounds altogether apart from the line of argument adopted. The editor, however, in the number of the *Gazette* just to hand, publishes his justification in terms which are hardly free from the 'personalities' to which he objects in his contribution; and this can be consulted by those who wish to pursue the subject further."

The editorial article referred to is as follows:

"Under the caption 'American nomenclature,' the editor of the *Journal of Botany* prints in the July number a portion of a private letter from some American correspondent in which occurs the following:

"The only two botanical journals are controlled by reformers. * * * The journals in question will not accept articles which give a true account of what has been said against the American system in Berlin and Vienna. A notice stating the facts was sent to SCIENCE, and * * * suppressed. It was then sent to the *Botanical Gazette*, but was declined."

"Inasmuch as the editor has sufficient grace to recognize this charge of suppression of the truth as a serious one, it would seem to have been his duty to determine whether it was true or false before publishing it. He could hardly have failed to observe that the *Gazette* has been publishing articles adverse to the reform movement in nomenclature, and had he re-examined them he would have found four of the six on this topic by opponents of reform and only two in favor of it. Another, likewise adverse, is published in this number. We challenge our

readers to say whether this shows a spirit of fairness or a desire to suppress discussion. Does it even indicate an inclination to refuse 'articles which give a true account of what has been said against the American system?'

"So much the editor of the *Journal* could have inferred from the action of the *Gazette*. It is enough to raise at least a presumption that his correspondent's statement was untrue. But he prefers to assume that what the *Gazette* has rejected has been rejected for the purpose of suppressing the truth.

"As a matter of fact the *Gazette* has rejected but one article on the subject of nomenclature. The article 'suppressed' by SCIENCE was rejected by us because it contained numerous objectionable personalities. In returning the MS. we took pains to inform the author that we objected only to the personalities, *not* to his opinion on nomenclature, and that if the personalities were eliminated the paper would be accepted. When the MS. was returned to the editor, however, it had been so greatly amplified that it would have filled at least thirteen pages of the *Gazette*. It was therefore returned to the writer with a request to condense it, and he was offered any space up to five pages (about the space required by the original paper), but he declined to alter the MS., and finally withdrew it.

"It is difficult to believe that a wish to be fair to what he is pleased to call 'the arbitrary dicta of certain American botanists' animates the utterances of the editor of the *Journal of Botany*. If it does it is at least curious that two scientific men should come to such opposite conclusions upon the same facts as do Mr. James Britten and a strenuous but gentlemanly opponent whose name we withhold but whose voluntary words we are permitted to quote:

"I have greatly regretted the ill-natured statements of J. Britten, especially those in which he implies that there has been any unfair suppression of opinion by the *Gazette*. I am confident that whatever has been rejected by the *Gazette* has been refused for the best reasons and for the sake of harmony and the best good of all concerned."

It would seem certain from the above that no attempt has been made either by SCIENCE or by the *Botanical Gazette* to suppress discussion of

botanical nomenclature. Probably no American journal wishes to suppress discussion, but it is evidently impossible to accept everything presented, and but few journals would care to print an article such as that contained in the July number of the *Journal of Botany*.

J. McKEEN CATTELL.

BLOOD EXAMINATION IN DISEASE.

The suggestion of Prof. Le Conte that some notice be taken of articles in which statements are made that are liable to mislead, or that are absolutely erroneous, calls to mind an article in the *Scientific American Supplement* for May 4, 1895 (p. 16, 126), by Prof. John Michels, entitled "Does a nucleus exist in the red corpuscles of mammalian blood?" In it the following assertion is made:

"It is a remarkable fact that although a knowledge of blood is of such importance and probably the key to a perfect knowledge of the treatment of disease, little or next to nothing is known relating to its physiological properties, its constituents or its effects on the human economy in health or disease. No physician ever makes a microscopical examination of blood in making his diagnosis, and if he did, he would be unable to interpret the appearances he would notice, for there is no guide to the subject, the medical profession remaining under a cloud of ignorance in regard to this matter, and they appear to be content to wait to have this knowledge forced upon them by chemists and biologists, rather than make any effort on their own part to relieve their condition of disgraceful ignorance."

That there still remains much to be learned regarding the blood is undeniable. But that the medical profession is in a state of ignorance in regard to it, or that no one ever makes a microscopical examination of blood in making his diagnosis, is absolutely false. Since the discovery of the hematozoa of malaria by Laveran, in 1880, thousands of cases of malarial fever have been diagnosed absolutely by blood examination. All late books on the practice of medicine refer to this as a valuable aid to diagnosis in this disease. Dr. Wm. Osler, of John Hopkins University, who has made a special study of malarial diseases, can, perhaps, give Prof. Michel some information on this point.

So, too, in cases of anemia. An examination of the blood will infallibly diagnose the

case, and all physicians in cases of doubt make this examination or have it made. Special instruments like the haemacytometer of Gowers or Thoma, or the haemoglobinometer of Gowers, have been made for this purpose and can be purchased from all dealers in microscopical instruments.

The disease known as Filariasis can be and is diagnosed by blood examination. The parasites causing this disease occur in the immature state in the blood, passing, as they mature, into the lymphatics. These parasites are truly remarkable from the fact that they are found in the blood only at night, being almost or entirely absent in the daytime; if, however, the patient sleep during the day this is reversed, thus showing that the condition of sleep is an important factor in determining the presence of the organisms.

From these facts it would seem that the medical profession is not in quite as 'dense' a state of ignorance regarding the blood as Prof. Michels would have his readers believe, and that they do make use of blood examination in the diagnosis of disease.

JOSEPH F. JAMES.

WASHINGTON, D. C., Sept. 4, 1895.

SCIENTIFIC LITERATURE.

The Science of Mechanics. A Critical and Historical Exposition of its Principles. By DR. ERNST MACH, Professor of Physics in the University of Prague. Translated from the Second German Edition by Thomas J. McCormack. The Open Court Publishing Co., Chicago.

The Science of Mechanics is an English translation of the German treatise by Professor Ernst Mach, on *The Development of Mechanics*; a work whose ability and importance entitle it to critical attention. While not a complete history of the science, it deals with the subject by the historical method and purports to be a philosophical discussion of the nature, origin and relations of those ideas and principles in mechanics which, when thus linked together, give an intelligible and comprehensive view of the science as it now is, and of the sometimes tortuous way by which it reached its present state. The book as a whole is unique, and is a valu-

able addition to any library of science or philosophy.

The author's well-known psychological bent is here directed to getting rid of metaphysical obscurities that befog the discussions of the seventeenth and eighteenth century physicists. He presents mechanics as a physical rather than a mathematical science, employing mathematics to some extent, necessarily, but with care not to make of a proposition in mechanics a mere peg on which to hang mathematical formulæ.

After a brief introduction, the work is arranged in a historical view of the development of the principles of statics, to which a hundred and twenty pages are devoted; then about an equal space is given in the same manner to dynamics, this being the order in which the science actually grew up. These divisions overlap somewhat, the former being carried well into the eighteenth century, while the latter begins with Galileo in the seventeenth century, but the order is, on the whole, very satisfactory.

Although the subject-matter of the first chapter may be of less immediate interest than that of the next, yet the author's treatment of it and his philosophical discussion of the early investigators' work and methods of working is most interesting, while the manner in which he shows how a principle has been employed *in essence* by one and another such investigator in its application to special and apparently unrelated questions, before some one makes the happy generalization that gives it the force of a law, is admirable. As one example among others, it is shown how the principle of virtual velocities was made use of by Stevinus in the sixteenth century, and later by Galileo, Torricelli and others before 'the universal applicability of it to all cases of equilibrium was perceived by John Bernoulli,' early in the eighteenth century.

"They that know the entire course of the development of science will, as a matter of course, judge more freely and more correctly of the significance of any present scientific movement than they who, limited in their views to the age in which their own lives have been spent, contemplate merely the momentary trend

that the course of intellectual events takes at the present moment." (p. 7.) The work exhibits this forcibly and repeatedly. Thus, by an extension of the principles employed by Stevinus in the study of hydrostatics, the author deduces a proposition which is now readily recognizable as a special case of Green's Theorem. "We may accordingly," says Professor Mach, "see into the force-system of a fluid in equilibrium, or, if you please, see out of it, systems of forces of greater or less complexity, and thus reach by a short path propositions *a posteriori*. It is a mere accident that Stevinus did not light on these propositions. The method here pursued corresponds exactly to his." (p. 109.)

The process from special cases to general principles is of course one of economy, and we might expect that any opportunity thus to economize would be at once seized upon. Says the author, "economy of communication and of apprehension is of the very essence of science," and this economy, serving at first to satisfy mere bodily wants, becomes later a potent factor in the development of science in its more advanced and specialized forms. At many points in the book we are reminded of this thesis, but almost immediately after it is stated we are brought face to face with a feature in the history of science that seems in contradiction to it, for after recounting the points which Archimedes, in beginning his study of equilibrium, assumed as self-evident, and then presenting that philosopher's mode of establishing the law of the lever, we are introduced to a succinct statement of the different methods by which Galileo, Huygens, Lagrange and others demonstrated the same law. We may believe that, in part, various philosophers produced new demonstrations because they saw or thought they saw fallacies in the reasoning of their predecessors, but this, we think, is not the principal reason. The fact is rather an illustration of the other fact that, in olden times, a problem once stated, existed, in the estimation of many, for the purpose of bringing out *all the solutions that could be found*. Hence the multiplicity of solutions to various problems as, for example, the many proofs of Euclid's Forty-seventh. There does not seem to be much economy of

time or labor in this. Professor Mach recognizes and condemns this tendency, calling it a 'mania for demonstration in science.' It is a fact that variety in the solutions of problems in mechanics led to the development of principles not before recognized, and thus resulted in an expansion of the science. This is shown by Professor Mach where the generalization of the principle of the lever by Leonardo da Vinci brings into prominence the principle of statical moments; and in like manner other advances are introduced, but it was not for the sake of these, nor yet in the interest of economy, that the new demonstrations were produced.

It is shown that the celebrated investigation of the inclined plane by Stevinus virtually involves the principle of the parallelogram of forces, and the principle itself is then stated and the fact commented on that Varignon as well as Newton determined it. The importance of the principle in both statics and kinetics is very properly recognized, but surely it scarcely needs pointing out that the statement and conception of the principle in connection with the parallelogram at this day is not most economical in mental labor or in manual application. It accords well with the cumbersome form in which many statements were made early in the development of science, and in their time the forms were excusable, but that a writer should continue to employ this principle now in the form in which it was enunciated by Newton is not an indication of any economical tendency. For the science has got beyond that. So soon as the idea is accepted that the result of several forces acting simultaneously upon a particle is the same, whether they are considered independently of one another or collectively, the graphic composition of the forces by vectorial addition becomes at once the simplest and most rational method. This, for two forces and their resultant, gives the triangle and dispenses with the parallelogram and diagonal idea altogether, besides serving equally well for three forces in equilibrium. As good a treatise on mechanics can be produced to-day without any reference to the parallelogram of forces as with it, and such is now the tendency. If the idea of 'economy of communication and of apprehension' is to prevail we must carry out this ten-

dency, but it will be done, if at all, only after an unduly prolonged, wasteful adherence to the parallelogram.

In treating of the development of dynamics, attention is confined principally to the achievements of Galileo, Huygens and Newton. The exposition of the work of Galileo is excellent, marking out in clearest lines his superiority as a truly scientific investigator over all his predecessors and most of his successors. His greatest work, of course, was his determination of the laws of falling bodies, and consequently of uniformly accelerated motion. In everything concerning the relation of motion to the circumstances that affect it, Galileo had to make his way as a pioneer. After first examining whether the velocity of a falling body varied directly as the distance, and abandoning this for the assumption that it varied as the time, he was led to a correct idea of acceleration, and also to that of force as measured by the product of mass and acceleration. Owing to the physical limitations under which he was obliged to perform his experiments, it was necessary for him to make various assumptions, whose validity always had to be proven. For instance, he retarded the motion of falling bodies by causing them to descend inclined planes, and then examined the peculiarities of their motion upon the assumption that "a body which falls through the height of an inclined plane attains the same final velocity as a body which falls through its length."

The reasoning by which he felt warranted in making this assumption brought him to the conclusion that if a body, in falling down the length of an inclined plane, acquired a velocity different from that gained by falling through its height, "a heavy body could, by an appropriate arrangement of inclined planes, be forced continually upwards solely by its own weight." But besides justifying the assumption logically he verified it experimentally. Both his reasoning and his experimentation were confined to the action of single bodies. Later, when Huygens solved the problem of the centre of oscillation of a compound pendulum he made use of a principle which, in its ultimate nature, was like that employed by Galileo, as follows: "In whatsoever manner the

material particles of a pendulum may by mutual interaction modify each other's motions, in every case the velocities acquired in the descent of the pendulum can be such only that by virtue of them the centre of gravity of the particles, whether still in connection or with their connections dissolved, is able to rise just as *high* as the point from which it *fell*. Huygens found himself compelled, by the doubts of his contemporaries as to the correctness of this principle, to remark that the only assumption implied in the principle is that heavy bodies of themselves do not move upwards;" (p. 174), and this principle, as Professor Mach points out, is a *generalization of one of Galileo's ideas*.

The author regards Huygens as in every respect the peer of Galileo, a rank which perhaps few would deny him. The above principle which he introduced makes what we now call the *work* done on a body by gravity, the condition determinative of the velocity it acquires, and this, more than anything else, marks the difference between Huygens' point of departure and that of Galileo and of Newton. All three recognized the fact of accelerations which they ascribed to *force* as a cause whose nature was unknown. Says the author: "That which in the mechanics of the present day is called *force* is not a something that lies latent in the natural processes, but a measurable, actual circumstance of motion, the product of the mass into the acceleration." (p. 246.) But this product is only one way of measuring the mutual actions involved, for not only do bodies influence one another as to velocities, but also as to displacements, and either of these may be made the basis of measuring the force. "We may, therefore, as it suits us, regard the *time* of descent or the *distance* of descent as the factor determinative of velocity. If we fix our attention on the first circumstance, the concept of force appears as the original notion, the concept of work as the derived one. If we investigate the influence of the second fact first, the concept of work is the original notion. * * * In this case we know force only as the limiting value of the ratio which increment of work bears to increment of distance.

Galileo cultivated by preference the first of these two methods. Newton likewise preferred

it. Huygens pursued the second method, without at all restricting himself to it." (p. 250.)

When we recollect that the adoption of 'work' as the fundamental concept of mechanics by J. R. Mayer, scarce a half century ago, was the introduction of modern views and methods in physics, and that when Professors Clifford and Tait, in still more recent times, were wont to dwell upon the consideration of force as a space-rate of change in work or energy (or potential), their ideas were regarded as novel and rather disturbing, it is refreshing to find Huygens ranged alongside of the nineteenth century physicists, though chronologically sandwiched between Galileo, who founded the science of dynamics, and Newton, of whom the author says, 'since his time no essentially new principle has been stated.' But, as Professor Mach reminds us, Huygens' principle was by no means well received by his contemporaries, notwithstanding it was his chief performance.

Naturally the achievements of Newton come in for the largest share of attention. The extent of his achievements and the profound and lasting impression which they made upon science compel, in any critic, the most searching scrutiny. It is necessary, too, to distinguish those discoveries and reflections which are Newton's own from those which he accepted from his predecessors and made more available by his clear perception of their relation to physical science in general and by his lucid formulation of them in laws and principles. This distinction has been made many a time, and doubtless many a one has wished to protest against certain of Newton's views, but it must be admitted that except for the old fashioned form of his statements, and the geometrical form of the demonstrations, surprisingly little of his writings has been altered to advantage. So far as his investigations are confined to facts, with abstention from every form of speculation, that is, so far as he conforms strictly to his assertion that he does not frame hypotheses, Professor Mach finds little but pleasure in his great work, and only objects to its form. But in his famous view concerning absolute time, space and motion, Newton departs from a consideration of physical facts, enters into psychology and, in the estimation of the author, makes statements

and distinctions that are not justifiable and which he criticises severely. Yet after reading the fifty pages or more that are devoted to the rather unfavorable consideration of Newton's fundamental statements in mechanics, one cannot help feeling that the last word on the subject has by no means been said. When the author says, "We arrive at the idea of time, to express it briefly and popularly, by the connection of that which is contained in the province of our memory with that which is contained in the province of our sense perception," we feel that Maxwell's statement that the idea of time originated probably 'in the recognition of an order of sequence in our states of consciousness' is an improvement in form upon the author's, and is more satisfactory, while conforming much more nearly to the Newtonian conceptions. As substitutes for Newton's enunciations Professor Mach offers three experimental propositions and two definitions as being 'much more simple, methodically better arranged, and more satisfactory.' In so far as his criticisms are endorsed the substitute propositions might be approved in substance, but their form savors of pedantry and they have the defect of excessive conciseness; they are therefore technical, and in consequence they require, each on its own account, a good deal of explanation. They can only be called simple for those who are already pretty well aware of what they state, but they prepare us for the remark: "We join with the eminent physicists Thomson and Tait in our reverence and admiration of Newton. But we can only comprehend with difficulty their opinion that the Newtonian doctrines still remain the best and most philosophical foundation of the science that can be given." (p. 245.)

A chapter is devoted to the extension of the principles, in which the reader will find an interesting treatment of the controversy between Descartes and Leibnitz, with their respective followings, over the conservation of momentum and of *vis viva*, with D'Alembert's final adjustment of it. The merits of D'Alembert's principle are enlarged upon we think justly, it being shown to embody within it all that is involved in Gauss' principle of least constraint. The work abounds in such comparisons and analyses as, after an

account of Clairaut's treatise on the figure of the earth, we learn that 'in the theory of Clairaut here presented is contained, beyond all doubt, the idea that underlies the doctrine of *force-function* or *potential*, which was afterwards developed with such splendid results by Laplace, Poisson, Green, Gauss and others.' (P. 398).

In the section on mechanical units, adapted to American usage by Mr. C. S. Peirce we notice the suggestion that the unit of acceleration be called a 'galileo,' as one more contribution to supply 'a long felt want.' The suggestion is at once adopted in the illustrations that follow.

Under 'The formal development of mechanics' is presented a view of the characteristic *classes* of problems that have arisen. This, together with a discussion of the various points of view, theological, animistic and mystical, of the great investigators, a section on analytical mechanics, and one on the economy of science, makes a most readable and enjoyable chapter.

The final chapter treats of the relations of mechanics to other departments of science, and is the least satisfactory one in the book. It opens with the declaration that "purely mechanical phenomena do not exist;" an arbitrary assertion which is explained by the equally arbitrary one that 'with dynamic results are always associated thermal, magnetic, electrical and chemical phenomena.' The statements are arbitrary because there is no proof of them. The author deprecates explaining all physical phenomena by mechanical ideas, saying, "we have no means of knowing, as yet, which of the physical phenomena go *deepest*, whether the mechanical phenomena are perhaps not the most superficial of all, or whether all do not go equally deep." Precisely; and for that reason, if for no other, we would take exception to the opening remark quoted above. Even if it were shown that no supposed mechanical phenomenon occurred without one or more of the other effects mentioned, the proposition would be by no means proven. Attraction, repulsion and strain are the very essence of mechanics and it is by no means certain that they are not the essence of other branches of physics also. There is nothing to show that magnetic, electrical and even chemical phenomena may not be ultimately and purely mechanical in their nature.

The translation is occasionally very free, but generally faithful to the meaning of the original, and only varied from it in form, to make the statements more lucid. This effect is heightened by the insertion of several brief notes by the translator.

Reproductions of quaint old portraits and vignettes give piquancy to the pages. The numerous marginal titles form a complete epitome of the work; and there is that invaluable adjunct, a good index.

Altogether the publishers are to be congratulated upon producing a technical work that is thoroughly attractive in its make-up.

D. W. HERING.

UNIVERSITY OF THE CITY OF NEW YORK.

On a Collection of Mammals from Arizona and Mexico, made by W. W. Price, with Field Notes by the Collector. By J. A. ALLEN. Bull. American Museum Natural History, vol. VII., pp. 193-258, June 29, 1895.

This important paper is based chiefly on a collection of 1500 specimens of small mammals obtained by W. W. Price in 1894 in southeastern Arizona. Mr. Price contributes an itinerary and descriptions of localities at which collections were made—a useful feature too often omitted in faunal papers. He also attempts to define five life zones, but fails to correlate them with the zones now commonly recognized in the region. His *first* is wholly Lower Sonoran; his *second* comprises the upper part of the Lower, and lower part of the Upper Sonoran; his *third* is the upper or *juniper belt* of the Upper Sonoran; his *fourth* is the Transition, and his *fifth* the Boreal.

The annotated list of mammals by Dr. Allen, with Mr. Price's field notes, covers 58 pages and is a great addition to the published record of our knowledge of Arizona mammals. Several changes in nomenclature are made and one species is described as new (*Thomomys cervinus*, a pocket gopher from Phoenix). The other new forms were described by Dr. Allen in a previous paper. *Perognathus conditi* and *Perodipus chapmani* are allowed to stand as species, although it has not been shown how the former differs from *Perognathus paradoxus*, or the latter from *Perodipus ordi*.

All of the wood rats are lumped under a

single species, *Neotoma mexicana* Baird, and the extraordinary opinion is expressed that *N. albigula* Hartley 'is not separable from *N. mexicana*.' Here, as in a previous paper, the author shows himself hopelessly at sea. *Neotoma albigula* and *N. mexicana* not only inhabit different life zones but belong to different groups or subdivisions of the genus!

The Arizona form of the Plains Prairie Dog is given as a distinct species, but anyone who will take the trouble to compare it with specimens from New Mexico and Texas will see that at most it is only a subspecies. On the other hand, the long-eared Arizona Jack Cottontail is given as a subspecies, though very distinct from any other known rabbit.

By curious lapse of memory the round-tailed spermophile (*Spermophilus tereticaudus*) is allowed to remain in the subgenus *Ictidomys*—a subgenus erected by Dr. Allen in 1877 for species with narrow elongate skulls. The species originally referred to it are *tereticaudus*, *tridecemlineatus* and *franklini*. *S. tereticaudus* has one of the shortest and broadest skulls known in the whole genus *Spermophilus*, but, probably by accidental transposition of skulls, it was described by Dr. Allen as long and slender. When his attention was called to the matter he very properly withdrew *tereticaudus* from the group and suggested that *13-lineatus* be taken as the type of *Ictidomys*, no type having been designated in the original description. But in the present paper the short skulled *tereticaudus* is again placed in *Ictidomys*!

Say's ground squirrel (*Spermophilus lateralis*) is persistently referred to the genus *Tamias*—a genus with which it has no affinity whatever and to which it bears only the most superficial resemblance.

With respect to the white-footed mice of the *Peromyscus sonoriensis* group, it is not likely that the last word has been said.

The generic name *Adelonycteris*, adopted from Harrison Allen for the large Brown Bat, has no claim for recognition, being antedated by at least two names of equal pertinency.

The specific name now in current use for the Mountain Sheep (*Ovis canadensis* Shaw) is replaced by *O. cervina* Desm. without apparent reason. Both names were published in 1804,

but there is no evidence that *cervina* antedates *canadensis*. In the absence of positive proof of priority such changes are most unfortunate and not likely to stand.

Passing from technical matters to the substance of the paper, one finds much of interest and numerous previously unpublished records. And it is gratifying to learn that elk still inhabit the White Mountains on the boundary between Arizona and New Mexico, where one was shot August 10, 1894. It is to be regretted that the specimen was not preserved.

C. H. M.

La sensibilité de l'œil aux couleurs spectrales. M. PARINAUD. *Revue Scientifique*, Sér. 4, T. 3, 709-714. June 8, 1895.

In a recent number of the *Revue Scientifique* Parinaud gives the results of certain interesting experiments upon the relative sensitiveness of the eye to spectral colors seen under different conditions of retinal adaptation. Two degrees of adaptation were used, one that of the eye in ordinary vision, the other that of the eye from which light has been completely excluded for 20-30 minutes. The following little table gives

| Condition of the Retina. | A | B | C | D | E | F | G | H |
|--------------------------|------------------------|-----------------|-----------------|-----------------|-----------------|-----------------|-----------------|-----------------|
| | 20-30 min. darkness... | ? | $\frac{1}{300}$ | $\frac{1}{100}$ | $\frac{1}{10}$ | 1 | 1 | $\frac{1}{100}$ |
| Ordinary conditions... | ? | $\frac{1}{300}$ | $\frac{1}{100}$ | $\frac{1}{10}$ | $\frac{1}{100}$ | $\frac{1}{300}$ | $\frac{1}{100}$ | ? |

the general results of the experiments, the letters standing for the Fraunhofer lines. While the figures are not to be taken in any sense as absolute, there are several interesting relations that appear in them.

The red end of the spectrum, for example, appears wholly unaffected by adaptation, though the place of greatest brightness shifts decidedly toward the violet. It was observed further that, with the adapted eye and the low intensities of light used with it, colors from the yellow onward to the violet (*i. e.*, the colors which are influenced by adaptation) appeared colorless; in other words, adaptation of the eye decreases the saturation of the colors seen until they at last appear entirely white. The red end is seen as red if seen at all. A third observa-

tion was that no adaptation whatever exists in the *fovea* (retinal point of clearest vision). It is consequently blind to lights that are yet easily seen by adjacent regions, and all colors are seen by it as colors if seen at all. The relations of these observations to color theories the author has reserved for succeeding papers. It is to be regretted that M. Parinaud has not coördinated his work with that of von Bezold, Hillebrand, König, Christine Ladd Franklin and others, who have, one or another of them, made all or nearly all of these observations before.

E. C. SANFORD.

SCIENTIFIC JOURNALS.

THE PHYSICAL REVIEW, VOL. III., NO. 2, SEPTEMBER-OCTOBER.

A Study of the Polarization of the Light Emitted by Incandescent Solid and Liquid Surfaces: By R. A. MILLIKAN. In spite of its important bearing upon the whole theory of radiation, the subject of polarization by emission appears to have been heretofore almost wholly neglected. As is pointed out by Dr. Millikan in the brief historical introduction to his own observations, no quantitative study of this subject has yet been made; and even qualitative observations appear to be rare. Having a clear field, Dr. Millikan has therefore undertaken a thorough investigation of the phenomenon. Experiments were first made in order to make certain that the effect is not due to refraction through the heated air at the incandescent surface. For this purpose a piece of platinum foil was brought to incandescence *in vacuo*. The light emitted showed the same degree of polarization as was observed when air was present. It thus appears that the polarization occurs within the radiating body.

Qualitative observations were next made upon a great variety of substances, in order to determine to what extent the phenomenon depends upon the nature of the surface. In all cases it was found that the polarization was in a plane perpendicular to the plane of emergence. Most metals showed a strong polarization, especially at grazing emergence; and provided the surfaces were not altered by oxidation, the behavior of molten metals was similar to that of

solids. Non-metallic substances, such as glass and porcelain, showed the effect in less degree than did the metals. The transparency or non-transparency of the material appears to have little influence upon the amount of polarization observed. For quantitative observations the author used the polariscope of Cornu, an instrument quite simple in construction and yet capable of considerable accuracy. The present paper contains a discussion of the sensitiveness of the instrument, together with a few observations made with it; but the discussion of most of the quantitative work is postponed until the second half of the paper, which will appear in the November number.

Alternating Currents when the Electromotive Force is of a Zigzag Wave Type. By E. C. RIMINGTON. Of course no dynamo will give an E. M. F. curve of the zigzag form. Nevertheless when certain harmonics are present in unusual prominence this shape of curve is sometimes approached. Mr. Rimington has investigated the relation between current and electromotive force in an inductive circuit for the ideal case, in order to be able to predict roughly what will occur in practice. The mathematical methods used are novel, and results are obtained in such form as to be readily available for calculation. Perhaps what will most strongly appeal to the reader are the diagrams giving the curves of electromotive force current for certain assumed values of the resistance and inductance. Diagrams are also given for the case of an E. M. F. curve of the rectangular type.

On Ternary Mixtures. By W. D. BANCROFT. This is a continuation of an article begun in the July number, which has already been noticed in SCIENCE. Further abstract will be postponed until the article is completed.

On a Simple Method of Photographically Registering the Infra-Red Energy Spectrum: By KNUT ÅNGSTRÖM. In this paper are described two forms of apparatus for obtaining autographic bolometer records, the results achieved being similar to those obtained by Langley in his recent work on the infra-red solar spectrum. Dr. Ångström makes no attempt to improve upon the elaborate apparatus of Langley, the wonderful results of which he does not hope to equal. But, as he very truly remarks, "such

an instrument can only be obtained by a richly endowed laboratory.' His object is, therefore, to simplify the method so as to bring the apparatus within the reach of laboratories of only moderate equipment. The method proposed can scarcely be described here. Tests made with it in recording the infra-red spectra of various flames, appear, however, to be satisfactory. The author's aim can perhaps best be stated in his own words: "To construct an apparatus which shall bear the same relation to that of Langley as does the direct vision spectroscope to the larger instruments of its class."

On the Electrolytic Conductivity of Concentrated Sulphuric Acid. By K. E. GÜTHE and L. J. BRIGGS. The authors have determined the conductivity of strong sulphuric acid at different temperatures and concentrations, with especial reference to the concentration corresponding to the hydrate $H_2SO_4 + H_2O$. Measurements were made by the bridge method with an alternating current, a sensitive dynamometer being used instead of a telephone. The results are given in tables, and also in the form of four curves, which show the relation between molecular volume and molecular conductivity at temperatures of 0° , 10° , 18° and 25° . Each of the four curves has a well-marked minimum at the molecular volume 32.1. If curves are drawn with concentrations instead of molecular volumes the minima do not occur at the same points. From this the authors draw the important conclusion that 'it is not the concentration but the molecular volume which determines the conductivity of the acid.' Interesting results are obtained for the conductivity of the crystalline hydrate $H_2SO_4 + H_2O$. The values obtained are perfectly definite, and appear to be free from errors due to the presence of unsolidified acid. The conductivity is found to be much smaller than that of the liquid, even when the latter is undercooled. A rapid diminution in resistance is, however, noticeable as the temperature approaches the melting point ($7^\circ.5$).

Book Notices. HELM: Grundzüge der Mathematischen Chemie. OSTWALD'S Klassiker der Exacten Wissenschaften. MACH: Popular Science Lectures. Proceedings of the Electrical Society of Cornell University. NABER: Standard Methods in Physics and Electricity criticised.

NEW BOOKS.

- A Text-book of the Principles of Physics.* ALFRED DANIELL. 3d Edition. New York and London. 1895. Pp. xv+782. \$4.00.
- The Great Frozen Land.* FREDERICK GEORGE JACKSON. London and New York, Macmillan & Co. 1895. Pp. xviii+297. \$4.50.
- Climate and Baths of Great Britain.* (Vol. I.) Being the report of a committee of the Royal Medical and Chirurgical Society of London. London and New York, Macmillan & Co. 1895. Pp. xvi+640. \$6.50.
- The Practice of Massage.* A. SYMONS ECCLES. New York and London, Macmillan & Co. 1895. Pp. xii+377. \$2.50.
- The Theory and Practice of Counter Irritation.* H. CAMERON GILLIES. London and New York, Macmillan & Co. 1895. Pp. xii+236. \$2.50.
- The Production of Tin in Various Parts of the World.* CHARLES M. ROLKER. Washington. Government Printing Office. 1895. Pp. 88.
- Handbuch der Physiologischen Optik.* H. VON HELMHOLTZ. 2d Edition, Nos. 1-10. Hamburg und Leipzig, Leopold Voss. 1886-1895. Pp. 800.
- Graduate Courses.* Compiled by an editorial board of graduate students. New York, Macmillan & Co. 1895. Pp. vi+135. 25 cts.
- Proceedings of the Royal Society of Victoria.* Vol. VII., New Series. London, Williams and Norgate. 1895. Pp. vi+339.
- The Psychology of Number.* By JAMES A. McLELLAN and JOHN DEWEY. New York, D. Appleton & Co. 1895. Pp. xiv+309. \$1.50.
- The Beginnings of Writing.* WALTER JAMES HOFFMAN. New York, D. Appleton & Co. 1895. Pp. xiv+209. \$1.75.
- Frail Children of the Air.* SAMUEL HUBBARD SCUDDER. Boston and New York, Houghton, Mifflin & Co. 1895. Pp. viii+279. \$1.50.
- Alternating Electric Currents.* EDWIN J. HOUTON and A. E. KENNELLY. New York, The W. J. Johnston Co. 1895. Pp. 225. \$1.00.
- The Stone Industry in 1894.* WILLIAM C. DAY. Washington, Government Printing Office. 1895. Pp. 83.

SCIENCE

NEW SERIES.
VOL. II. No. 40.

FRIDAY, OCTOBER 4, 1895.

SINGLE COPIES, 15 CTS.
ANNUAL SUBSCRIPTION, \$5.00.

GUSTAV E. STECHERT'S Recent Importation of Scientific Books.

BECKERT, TH. und DR. ALBANO BRAND. Hüttenkunde. Mit 235 in den Text gedruckten Figuren. 765 Seiten. gr. 8^o. Mk. 20.

BEHRENS, H. Anleitung zur mikrochemischen Analyse. Mit einem Vorwort von Prof. S. Hoogewerf in Delft. 224 Seiten mit 92 Figuren in Text. 8^o. Mk. 6.

BIEDERMANN, W. Elektrophysiologie. 1^{te} Abtheilung. Mit 136 Abbildungen. 440 Seiten. 8^o. Mk. 9.

BORCHERS, DR. W. Elektro-Metallurgie. Die Gewinnung der Metalle unter Vermittlung des elektrischen Stromes. 2^{te} verm. v. völlig umgearb. Auflage. 1^{te} Abtheilung, mit 87 Abbildungen. 160 Seiten. gr. 8^o. Mk. 6⁰⁰.

BUSCHAN, GEORG. Vorgesichtliche Botanik der Cultur-u. Nutzpflanzen der alten Welt auf Grund prähistorischer Funde. 268 Seiten. 8^o. Mk. 7⁰⁰.

DAMMER, DR. O. Handbuch der chemischen Technologie. Unter Mitwirkung von Direktor Th. Beckert, Dr. Bender, Dr. Benedikt, Dr. Börnstein u. A. herausgegeben. 2^{te} Band. Mit 235 in den Text gedruckten Figuren. gr. 8^o. Mk. 20.

DELAGE, YVES. La structure du protoplasma et les théories sur l'hérédité et les grands problèmes de la biologie générale. 878 pages. gr. 8^o cloth. frs 24⁰⁰.

DETMER, DR. W. Das pflanzenphysiologische Praktikum. Anleitung zu pflanzenphysiolog. Untersuchungen für Studierende u. Lehrer der Naturwissenschaften, sowie der Medicin, etc. 2^{te} völlig neubearbeitete Aufl. Mit 184 Abbildungen. 456 Seiten. 8^o. Mk. 9.

FOREL, DR. AUGUST. Der Hypnotismus, seine psycho-physiologische medicinische, strafrechtliche Bedeutung und seine Handhabung. 3^{te} verb. Aufl. mit Adnotationen von Dr. O. Vogt. 223 Seiten. gr. 8^o. Mk. 5.

FRANK, DR. A. B. Die Krankheiten der Pflanzen. Ein Handbuch für Land u. Forstwirte, Botaniker, etc. Erster Band, Die durch anorgan. Einflüsse hervorgerufenen Krankheiten. Mit 34 Holzschnitten. 2^{te} Aufl. 344 Seiten. 8^o. Mk. 6⁰⁰.

HIS, WILH. Die anatomische Nomenclatur. Nomina anatomica, Verzeichniss der von der anatomischen Gesellschaft auf ihrer 9. Versammlung in Basel angenommenen Namen. Mit 30 Abbildgn. im Text und 2 Tafeln. 180 Seiten. Mk. 7⁰⁰.

HOUDAILLE, F. Météorologie agricole. 204 pages cloth. fr. 3.

JAHRBUCH DER ELEKTROCHEMIE. Berichte über die Fortschritte des Jahres 1894. Im wissenschaftlichen Theile bearbeitet von Dr. W. Nernst. Im technischen Theile bearbeitet von Dr. W. Borchers. 1^{er} Jahrgang. 274 Seiten. gr. 8^o. Mk. 10.

JERUSALEM, WILH. Die Urtheilsfunction. Eine psychologische und erkenntniskritische Untersuchung. 269 Seiten. Mk. 6⁰⁰.

LOEWY, DR. A. Untersuchungen über die Respiration und Circulation bei Aenderung des Druckes und des Sauerstoffgehaltes der Luft. Mit 5 Curventafeln im Text. 155 Seiten. gr. 8^o. Mk. 4.

MEYER, DR. ARTH. Untersuchungen über die Stärkekörner der höheren Pflanzen. Mit 9 Tafeln u. 99 Text-Abbildgn. 318 Seiten. gr. 8^o. Mk. 20⁰⁰.

NIEDENZU, DR. FRANZ. Handbuch für botanische Bestimmungsübungen. Mit 15 Figuren im Text. 351 Seiten. 8^o. Mk. 4.

SCHAFER, DR. KARL. Suggestion und Reflex. Eine Critisch-experimentelle Studie über die Reflexphänomene des Hypnotismus. Mit 6 Tafeln in Lichtdruck und 11 Abbildungen im Text. 113 Seiten. gr. 8^o. Mk. 6⁰⁰.

SCHMIDT, DR. ALEX. Weitere Beiträge zur Blutlehre. Nach des Verfassers Tode herausgegeben. 247 Seiten. 8^o. Mk. 7.

SCHWARTZE, TH. Die Lehre von der Electricität und deren praktische Verwendung. Mit 153 in den Text gedruckten Abbildungen. 543 Seiten. 8^o. Mk. 10⁰⁰.

STEINHARDT, DR. EUGEN. Kurzes Lehrbuch der Chemie zum Gebrauch an Schulen und zur Selbstbelehrung. Zwei Theile. Erst. Teil; Anorganische Chemie. 418 Seiten. 8^o. Mk. 6⁰⁰.

VAN BIEVELIET, J. J. Elements de psychologie humaine. Cours professé à l'université de Gand. Avec 34 figures dans le Text. 317 pages. frs. 8.

ZEITSCHRIFT FÜR ANGEWANDTE MIKROSKOPIE herausgegeben von G. Martmann. Monthly. 1^{ter} Band 1^{tes} Heft. Per year, \$2.75.

ZEITSCHRIFT, Geographische, Herausgegeben von Dr. Alfred Hettner. 1^{er} Jahrg. 1^{es} Heft. Per year (12 N^{os}) \$4⁰⁰.

ZIMMERMANN, DR. A. Das Mikroskop. Ein Leitfaden der wissenschaftlichen Mikroskopie. Mit 231 Figuren im Text. 334 Seiten. gr. 8^o. Mk. 9.

ZITTEL, KARL A. VON. Grundzüge der Paläontologie (Paläozoologie). Mit 2048 in den Text gedruckten Abbildungen. 971 Seiten. gr. 8^o. $\frac{1}{2}$ mor. Mk. 25⁰⁰.

GUSTAV E. STECHERT,

810 Broadway, New York.

Macmillan & Co.'s New Publications

Lindsay.—An Introduction to the Study of Zoology. By B. LINDSAY, C. S., of Girton College, Cambridge. With 124 Illustrations and Diagrams. Pp. xix + 356, 12mo, cloth, \$1.60 net.

Cook, Shipley and Reed.—Molluscs and Brachiopods. By REV. A. H. COOKE, M. A., Fellow of King's College, Cambridge; A. E. SHIPLEY, M. A., Fellow of Christ's College, Cambridge; and F. R. C. REED, B. A., Trinity College, Cambridge. Illustrated. *Cambridge Natural History*. 8vo, cloth, pp. 535, \$3.25 net.

NEW VOLUME OF THE

Columbia University Biological Series.

Edited by HENRY FAIRFIELD OSBORN, *Da Costa Professor of Biology in Columbia College.*

Fishes, Living and Fossil.

An Outline of their Form and Probable Relationship.

By BASHFORD DEAN, Ph. D. Columbia, *Instructor in Biology, Columbia College.*

With Illustrations from the Author's original Pen Drawings. 8vo, cloth, \$2.50 net.

ALREADY PUBLISHED IN THE SAME SERIES.

From the Greeks to Darwin. The development of the evolution idea. By HENRY FAIRFIELD OSBORN, Sc. D. Princeton, *Da Costa Professor of Biology in Columbia College.* 8vo, cloth, \$2.00 net.

Amphioxus and Ancestry of the Vertebrates. By ARTHUR WILLEY, B. Sc. Lond., *Tutor in Biology, Columbia College, Balfour Student of the University of Cambridge.* With Illustrations. 8vo, cloth, \$2.50 net.

Stanley.—Studies in the Evolutionary Psychology of Feeling.

By HIRAM M. STANLEY, Member of the American Psychological Association. 8vo, cloth, pp. viii + 392. Price, \$2.25, net.

Harris.—Note-book on Plane Geometrical Drawing. With a chapter on Scales and an Introduction to Graphic Statics. By ROBERT HARRIS, Art Master at St. Paul's School: late Examiner to the Board of Intermediate Education, Ireland; Author of the 'Art Series of Drawing-books,' for Use in Public Schools. New Edition, Revised and Enlarged. 12mo, cloth, pp. 230. Price, 90cents, net.

Nitti.—Catholic Socialism. By FRANCESCO S. NITTI, Professor of Political Economy, at the University of Naples, author of 'Population and the Social System,' etc. Translated from the second Italian edition by MARY MACKINTOSH. With an Introduction by DAVID G. RITCHIE, M. A., Professor of Logic and Metaphysics in the University of St. Andrews. Pp. xx + 432, 8vo, cloth, \$3.50.

NEW VOLUME.

Columbia University Press.

Statistics and Sociology. Science of Statistics. Part 1.

By RICHMOND MAYO-SMITH, Ph. D., Professor of Political Economy and Social Science in Columbia College. 8vo, cloth, \$3.00 net.

MACMILLAN & CO., 66 Fifth Avenue, New York.

SCIENCE

EDITORIAL COMMITTEE : S. NEWCOMB, Mathematics ; R. S. WOODWARD, Mechanics ; E. C. PICKERING, Astronomy ; T. C. MENDENHALL, Physics ; R. H. THURSTON, Engineering ; IRA REMSEN, Chemistry ; J. LE CONTE, Geology ; W. M. DAVIS, Physiography ; O. C. MARSH, Paleontology ; W. K. BROOKS, Invertebrate Zoology ; C. HART MERRIAM, Vertebrate Zoology ; S. H. SCUDDER, Entomology ; N. L. BRITTON, Botany ; HENRY F. OSBORN, General Biology ; H. P. BOWDITCH, Physiology ; J. S. BILLINGS, Hygiene ; J. MCKEEN CATTELL, Psychology ; DANIEL G. BRINTON, J. W. POWELL, Anthropology.

FRIDAY, OCTOBER 4, 1895.

ADDRESS OF THE PRESIDENT, SIR DOUGLAS GALTON, BEFORE THE BRITISH ASSOCIATION FOR THE ADVANCEMENT OF SCIENCE.

CONTENTS:

| | |
|--|-----|
| <i>Address of the President, Sir Douglas Galton, before the British Association for the Advancement of Science</i> | 421 |
| <i>Electrification and Diselectrification of Air and other Gases</i> : LORD KELVIN, MAGNUS MACLEAN and ALEXANDER GALT..... | 433 |
| <i>Science or Poetry</i> : W. K. BROOKS..... | 437 |
| <i>Bibliography as a Feature of the Chemical Curriculum</i> : H. CARRINGTON BOLTON..... | 440 |
| <i>Agricultural Chemistry</i> : H. W. WILEY..... | 442 |
| <i>Proceedings of the Botanical Club, A. A. A. S., Springfield Meeting, August 29th to September 2d, 1895</i> : H. L. BOLLEY..... | 445 |
| <i>The Botanical Society of America</i> : CHARLES R. BARNES..... | 448 |
| <i>Scientific Notes and News</i> :..... | 449 |
| <i>A New Jurassic Plesiosaur from Wyoming</i> : W. C. KNIGHT. <i>The Earliest Name for Steller's Sea Cow and the Dugong</i> : T. S. PALMER. <i>An International Zoologist's Directory; Natural Science Training for Engineers; General</i> . | |
| <i>University and Educational News</i> | 453 |
| <i>Correspondence</i> :—..... | 453 |
| <i>Professor Halsted Replied To</i> : EMORY MCCLINTOCK. | |
| <i>Scientific Literature</i> :—..... | 454 |
| <i>Climate and Baths of Great Britain</i> : J. S. BILLINGS. <i>Ravitz's Leitfaden für histiologische Untersuchungen</i> : S. H. G. | |
| <i>Scientific Journals</i> :—..... | 456 |
| <i>Psyche</i> . | |
| <i>New Books</i> | 456 |

MSS. intended for publication and books, etc., intended for review should be sent to the responsible editor, Prof. J. McKeen Cattell, Garrison on Hudson, N. Y.

Subscriptions and advertisements should be sent to SCIENCE, 41 N. Queen St., Lancaster, Pa., or 41 East 49th St., New York.

My first duty is to convey to you, Mr. Mayor, and to the inhabitants of Ipswich, the thanks of the British Association for your hospitable invitation to hold our sixty-fifth meeting in your ancient town, and thus to recall the agreeable memories of the similar favor which your predecessors conferred on the Association forty-four years ago.

In the next place I feel it my duty to say a few words on the great loss which science has recently sustained—the death of the Right Hon. Thomas Henry Huxley. It is unnecessary for me to enlarge, in the presence of so many to whom his personality was known, upon his charm in social and domestic life; but upon the debt which the Association owes to him for the assistance which he rendered in the promotion of science I cannot well be silent. Huxley was preëminently qualified to assist in sweeping away the obstruction by dogmatic authority, which in the early days of the Association fettered progress in certain branches of science. For, whilst he was an eminent leader in biological research, his intellectual power, his original and intrepid mind, his vigorous and masculine English, made him a writer who explained the deepest subject with transparent clearness. And

as a speaker his lucid and forcible style was adorned with ample and effective illustration in the lecture room; and his energy and wealth of argument in a more public arena largely helped to win the battle of evolution, and to secure for us the right to discuss questions of religion and science without fear and without favor. It may, I think, interest you to learn that Huxley first made the acquaintance of Tyndall at the meeting of the Association held in this town in 1851.

About forty-six years ago I first began to attend the meetings of the British Association; and I was elected one of your general secretaries about twenty-five years ago. It is not unfitting, therefore, that I should recall to your minds the conditions under which science was pursued at the formation of the Association, as well as the very remarkable position which the Association has occupied in relation to science in this country. Between the end of the sixteenth century and the early part of the present century several societies had been created to develop various branches of science. Some of these societies were established in London, and others in important provincial centers. In 1831, in the absence of railways, communication between different parts of the country was slow and difficult. Science was therefore localised; and in addition to the universities in England, Scotland and Ireland, the towns of Birmingham, Manchester, Plymouth and York each maintained an important nucleus of scientific research.

Under these social conditions the British Association was founded in September, 1831. The general idea of its formation was derived from a migratory society which had been previously formed in Germany; but whilst the German society met for the special occasion on which it was summoned, and then dissolved, the basis of the British Association was continuity. The objects of

the founders of the British Association were enunciated in their earliest rules to be:

“To give a stronger impulse and a more systematic direction to scientific inquiry; to promote the intercourse of those who cultivated science in different parts of the British Empire with one another, and with foreign philosophers; to obtain a more general attention to the objects of science, and a removal of any disadvantages of a public kind which impede its progress.”

Thus the British Association for the Advancement of Science based its utility upon the opportunity it afforded for combination.

The first meeting of the Association was held at York with 353 members. As an evidence of the want which the Association supplied, it may be mentioned that at the second meeting, which was held at Oxford, the number of members was 435. The third meeting, at Cambridge, numbered over 900 members, and at the meeting at Edinburgh in 1834 there were present 1,298 members.

At its third meeting, which was held at Cambridge in 1833, the Association, through the influence it had already acquired, induced the Government to grant a sum of £500 for the reduction of the astronomical observations of Baily. And at the same meeting the General Committee commenced to appropriate to scientific research the surplus from the subscriptions of its members. The committees on each branch of science were desired “to select definite and important objects of science, which they may think most fit to be advanced by an application of the funds of the society, either in compensation for labor, or in defraying the expenses of apparatus, or otherwise, stating their reasons for their selection, and, when they may think proper, designating individuals to undertake the desired investigations.” The several proposals were submitted to the Committee of Recommendations, whose approval was necessary before they could be passed by the General Committee.

The regulations then laid down still guide the Association in the distribution of its grants. At that early meeting the Association was enabled to apply £600 to these objects.

I have always wondered at the foresight of the framers of the constitution of the British Association, the most remarkable feature of which is the lightness of the tie which holds it together. It is not bound by any complex central organization. It consists of a federation of Sections, whose youth and energy are yearly renewed by a succession of Presidents and Vice-Presidents, whilst in each Section some continuity of action is secured by the less movable Secretaries.

The governing body is the General Committee, the members of which are selected for their scientific work; but their controlling power is tempered by the law that all changes of rules, or of constitution, should be submitted to, and receive the approval of, the Committee of Recommendations. This Committee may be described as an ideal Second Chamber. It consists of the most experienced members of the Association. The administration of the Association in the interval between annual meetings is carried on by the Council, an executive body, whose duty it is to complete the work of the annual meeting (*a*) by the publication of its Proceedings; (*b*) by giving effect to resolutions passed by the General Committee; (*c*) it also appoints the Local Committee and organizes the *personnel* of each Section for the next meeting. I believe that one of the secrets of the long-continued success and vitality of the British Association lies in this purely democratic constitution, combined with the compulsory careful consideration which must be given to suggested organic changes.

The Association is now in the sixty-fifth year of its existence. In its origin it invited the philosophical societies dispersed

throughout Great Britain to unite in a cöoperative union. Within recent years it has endeavored to consolidate that union. At the present time almost all important local scientific societies scattered throughout the country, some sixty-six in number, are in correspondence with the Association. Their delegates hold annual conferences at our meetings. The Association has thus extended the sphere of its action; it places the members of the local societies engaged in scientific work in relation with each other, and brings them into cöoperation with members of the Association and with others engaged in original investigations, and the papers which the individual societies publish annually are catalogued in our report. Thus by degrees a national catalogue will be formed of the scientific work of these societies. The Association has, moreover, shown that its scope is coterminous with the British Empire by holding one of its annual meetings at Montreal, and we are likely soon to hold a meeting in Toronto.

The Association, at its first meeting, began its work by initiating a series of reports upon the then condition of the several sciences. A rapid glance at some of these reports will not only show the enormous strides which have been made since 1831 in the investigation of facts to elucidate the laws of nature, but it may afford a slight insight into the impediments offered to the progress of investigation by the mental condition of the community, which had been for so long satisfied to accept assumptions without undergoing the labor of testing their truth by ascertaining the real facts. This habit of mind may be illustrated by two instances selected from the early reports made to the Association. The first is afforded by the report made in 1832, by Mr. Lubbock, on 'Tides.'

This was a subject necessarily of importance to England as a dominant power at sea. But in England records of the tides

had only recently been commenced at the dockyards of Woolwich, Sheerness, Portsmouth and Plymouth, on the request of the Royal Society, and no information had been collected upon the tides on the coasts of Scotland and Ireland. The British Association may feel pride in the fact that within three years of its inception, viz. by 1834, it had induced the Corporation of Liverpool to establish two tide gauges, and the Government to undertake tidal observations at 500 stations on the coasts of Britain.

Another cognate instance is exemplified by a paper read at the second meeting, in 1832, upon the State of Naval Architecture in Great Britain. The author contrasts the extreme perfection of the carpentry of the internal fittings of the vessels with the remarkable deficiency of mathematical theory in the adjustment of the external form of vessels, and suggests the benefit of the application of refined analysis to the various practical problems which ought to interest shipbuilders—problems of capacity, of displacement, of stowage, of velocity, of pitching and rolling, of masting, of the effects of sails and of the resistance of fluids; and, moreover, suggests that large-scale experiments should be made by Government, to afford the necessary data for calculation.

Indeed, when we consider how completely the whole habit of mind of the populations of the western world has been changed, since the beginning of the century, from willing acceptance of authority as a rule of life to a universal spirit of inquiry and experimental investigation, is it not probable that this rapid change has arisen from society having been stirred to its foundations by the causes and consequences of the French Revolution?

One of the earliest practical results of this awakening in France was the conviction that the basis of scientific research lay in the accuracy of the standards by which

observations could be compared; and the following principles were laid down as a basis for their measurements of length, weight and capacity, viz.: (1) That the unit of linear measure applied to matter in its three forms of extension, viz.: length, breadth and thickness, should be the standard of measures of length, surface and solidity; (2) that the cubic contents of the linear measure in decimeters of pure water at the temperature of its greatest density should furnish at once the standard weight and the measure of capacity.* The metric system did not come into full operation in France till 1840; and it is now adopted by all countries on the continent of Europe except Russia.

The standards of length which were accessible in Great Britain at the formation of the Association were the Parliamentary standard yard lodged in the Houses of Parliament (which was destroyed in 1834 in the fire which burned the Houses of Parliament), the Royal Astronomical Society's standard and the 10-foot bar of the Ordnance Survey. The first two were assumed to afford exact measurements at a given temperature. The Ordnance bar was formed of two bars on the principle of a compensating pendulum, and afforded measurements independent of temperature. Standard bars were also disseminated throughout the country, in possession of the corporations of various towns.

The British Association early recognized the importance of uniformity in the record of scientific facts, as well as the necessity for an easy method of comparing standards and for verifying differences between instruments and apparatus required by various observers pursuing similar lines of investi-

*The liter is the volume of a kilogramme of pure water at its maximum density, and is slightly less than the liter was intended to be, viz., one cubic decimeter. The weight of a cubic decimeter of pure water is 1.000013 kilogrammes.

gation. At its meeting at Edinburgh in 1834 it caused a comparison to be made between the standard bar at Aberdeen, constructed by Troughton, and the standard of the Royal Astronomical Society, and reported that the scale "was exceedingly well finished; it was about $\frac{1}{5000}$ of an inch shorter than the five-feet of the Royal Astronomical Society's scale, but it was evident that a great number of minute, yet important, circumstances have hitherto been neglected in the formation of such scales, without an attention to which they cannot be expected to accord with that degree of accuracy which the present state of science demands." Subsequently, at the meeting at Newcastle in 1863, the Association appointed a committee to report on the best means of providing for a uniformity of weights and measures with reference to the interests of science. This committee recommended the metric decimal system—a recommendation which has been endorsed by a committee of the House of Commons in the last session of last Parliament.

British instrument makers had been long conspicuous for accuracy of workmanship. Indeed, in the eighteenth century practical astronomy had been mainly in the hands of British observers; for although the mathematicians of France and other countries on the continent of Europe were occupying the foremost place in mathematical investigation, means of astronomical observation had been furnished almost exclusively by English artisans.

The sectors, quadrants and circles of Ramsden, Bird and Carey were inimitable by continental workmen. But the accuracy of the mathematical instrument maker had not penetrated into the engineer's workshop. And the foundation of the British Association was coincident with a rapid development of mechanical appliances. At that time a good workman had done well if the shaft he was turning, or the cyl-

inder he was boring, 'was right to the $\frac{1}{32}$ of an inch.' This was, in fact, a degree of accuracy as fine as the eye could usually distinguish.

Few mechanics had any distinct knowledge of the method to be pursued for obtaining accuracy; nor, indeed, had practical men sufficiently appreciated either the immense importance or the comparative facility of its acquisition. The accuracy of workmanship essential to this development of mechanical progress required very precise measurements of length, to which reference could be easily made. No such standards were then available for the workshops. But a little before 1830 a young workman named Joseph Whitworth realized that the basis of accuracy in machinery was the making of a true plane. The idea occurred to him that this could only be secured by making three independent plane surfaces; if each of these would lift the other they must be planes and they must be true.

The true plane rendered possible a degree of accuracy beyond the wildest dreams of his contemporaries in the construction of the lathe and the planing machine, which are used in the manufacture of all tools. His next step was to introduce an exact system of measurement, generally applicable in the workshop.

Whitworth felt that the eye was altogether inadequate to secure this, and appealed to the sense of touch for affording a means of comparison. If two plugs be made to fit into a round hole they may differ in size by a quantity imperceptible to the eye, or to any ordinary process of measurement, but in fitting them into the hole the difference between the larger and the smaller is felt immediately by the greater ease with which the smaller one fits. In this way a child can tell which is the larger of two cylinders differing in thickness by no more than $\frac{1}{2000}$ of an inch.

Standard gauges, consisting of hollow cylinders with plugs to fit, but differing in diameter by the $\frac{1}{10000}$ or the $\frac{1}{100000}$ of an inch, were given to his workmen, with the result that a degree of accuracy inconceivable to the ordinary mind became the rule of the shop.

To render the construction of accurate gauges possible, Whitworth devised his measuring machine, in which the movement was affected by a screw; by this means the distance between two true planes might be measured to the one-millionth of an inch.

These advances in precision of measurement have enabled the degree of accuracy which was formerly limited to the mathematical instrument maker to become the common property of every machine shop. And not only is the latest form of steam engine, in the accuracy of its workmanship, little behind the chronometer of the early part of the century, but the accuracy in the construction of experimental apparatus which has thus been introduced has rendered possible recent advances in many lines of research.

Lord Kelvin said, in his Presidential Address at Edinburgh, "Nearly all the grandest discoveries of science have been but the rewards of accurate measurement and patient, long-continued labor in the sifting of numerical results." The discovery of argon, for which Lord Rayleigh and Prof. Ramsay have been awarded the Hodgkin prize by the Smithsonian Institution, affords a pregnant illustration of the truth of this remark. Indeed, the provision of accurate standards not only of length, but of weight, capacity, temperature, force and energy, are amongst the foundations of scientific investigation.

In 1842 the British Association obtained the opportunity of extending its usefulness in this direction. In that year the Government gave up the Royal Observatory at Kew

and offered it to the Royal Society, who declined it. But the British Association accepted the charge. Their first object was to continue Sabine's valuable observations upon the vibrations of a pendulum in various gases, and to promote pendulum observations in different parts of the world. They subsequently extended it into an observatory for comparing and verifying the various instruments which recent discoveries in physical science had suggested for continuous meteorological and magnetic observations, for observations and experiments on atmospheric electricity, and for the study of solar physics.

This new departure afforded a means for ascertaining the advantages and disadvantages of the several varieties of scientific instruments, as well as for standardizing and testing instruments, not only for instrument makers, but especially for observers by whom simultaneous observations were then being carried on in different parts of the world, and also for training observers proceeding abroad on scientific expeditions. Its special object was to promote original research, and expenditure was not to be incurred on apparatus merely intended to exhibit the necessary consequences of known laws.

The rapid strides in electrical science had attracted attention to the measurement of electrical resistances, and in 1859 the British Association appointed a special committee to devise a standard. The standard of resistance proposed by that committee became the generally accepted standard, until the requirements of that advancing science led to the adoption of an international standard.

In 1866 the Meteorological Department of the Board of Trade entered into close relations with the Kew Observatory, and in 1871 Mr. Gassiot transferred £10,000 upon trust to the Royal Society for the maintenance of the Kew Observatory,

for the purpose of assisting in carrying on magnetical, meteorological and other physical observations. The British Association thereupon, after having maintained this Observatory for nearly thirty years, at a total expenditure of about £12,000, handed the Observatory over to the Royal Society.

The *Transactions* of the British Association are a catalogue of its efforts in every branch of science, both to promote experimental research and to facilitate the application of the results to the practical uses of life. But probably the marvellous development in science which has accompanied the life-history of the Association will be best appreciated by a brief allusion to the condition of some of the branches of science in 1831 as compared with their present state.

At the foundation of the Association geology was assuming a prominent position in science. The main features of English geology had been illustrated as far back as 1821, and among the founders of the British Association, Murchison and Phillips, Buckland, Sedgwick and Conybeare, Lyell and De la Beche were occupied in investigating the data necessary for perfecting a geological chronology by the detailed observations of the various British deposits, and by their correlation with the continental strata. They are thus preparing the way for those large generalizations which have raised geology to the rank of an inductive science.

In 1831 the ordnance maps published for the southern counties had enabled the Government to recognize the importance of a geological survey by the appointment of Mr. De la Beche to affix geological colors to the maps of Devonshire and portions of Somerset, Dorset and Cornwall; and in 1835 Lyell, Buckland and Sedgwick induced the Government to establish the Geological Survey Department, not only for promoting geological science, but on account of its practical bearing on agriculture,

mining, the making of roads, railways and canals, and on other branches of national industry.

The ordnance survey appears to have had its origin in a proposal of the French Government to make a joint measurement of an arc of the meridian. This proposal fell through at the outbreak of the Revolution, but the measurement of the base for that object was taken as a foundation for a national survey. In 1831, however, the ordnance survey had only published the 1-inch map for the southern portion of England, and the great triangulation of the kingdom was still incomplete.

In 1834 the British Association urged upon the Government that the advancement of various branches of science was greatly retarded by the want of an accurate map of the whole of the British Isles; and that, consequently, the engineer and meteorologist, the agriculturist and geologist, were each fettered in their scientific investigations by the absence of those accurate data which now lie ready to his hand for the measurement of length, of surface and of altitude.

Yet the first decade of the British Association was coincident with a considerable development of geographical research. The Association was persistent in pressing on the Government the specific importance of sending the expedition of Ross to the Antarctic and of Franklin to the Arctic regions. We may trust we are approaching a solution of the geography of the North Pole; but the Antarctic regions still present a field for the researches of the meteorologist, the geologist, the biologist and the magnetic observer, which the recent voyage of M. Borchgrevink leads us to hope may not long remain unexplored.

In the same decade the question of an alternative route to India by means of a communication between the Mediterranean and the Persian Gulf was also receiving atten-

tion, and in 1835 the Government employed Colonel Chesney to make a survey of the Euphrates Valley in order to ascertain whether that river would enable a practicable route to be formed from Iskanderoon or Tripoli, opposite Cyprus, to the Persian Gulf. His valuable surveys are not, however, on a sufficiently extensive scale to enable an opinion to be formed as to whether a navigable waterway through Asia Minor is physically practicable, or whether the cost of establishing it might not be prohibitive.

The advances of Russia in Central Asia have made it imperative to provide an easy, rapid and alternative line of communication with our Eastern possessions, so as not to be dependent upon the Suez Canal in time of war. If a navigation cannot be established, a railway between the Mediterranean and the Persian Gulf has been shown by the recent investigations of Messrs. Hawkshaw and Hayter, following on those of others, to be perfectly practicable and easy of accomplishment; such an undertaking would not only be of strategical value, but it is believed it would be commercially remunerative.

Speke and Grant brought before the Association, at its meeting at Newcastle in 1863, their solution of the mystery of the Nile basin, which had puzzled geographers from the days of Herodotus; and the efforts of Livingstone and Stanley and others have opened out to us the interior of Africa. I cannot refrain here from expressing the deep regret which geologists and geographers, and indeed all who are interested in the progress of discovery, feel at the recent death of Joseph Thomson. His extensive, accurate and trustworthy observations added much to our knowledge of Africa, and by his premature death we have lost one of its most competent explorers.

The report made to the Association on the state of the chemical sciences in 1832

says that the efforts of investigators were then being directed to determining with accuracy the true nature of the substances which compose the various products of the organic and inorganic kingdoms, and the exact ratios by weight which the different constituents of these substances bear to each other.

But since that day the science of chemistry has far extended its boundaries. The barrier has vanished which was supposed to separate the products of living organisms from the substances of which minerals consist, or which could be formed in the laboratory. The number of distinct carbon compounds obtainable from organisms has greatly increased; but it is small when compared with the number of such compounds which have been artificially formed. The methods of analysis have been perfected. The physical, and especially the optical, properties of the various forms of matter have been closely studied, and many fruitful generalizations have been made. The form in which these generalizations would now be stated may probably change, some, perhaps, by the overthrow or disuse of an ingenious guess at nature's workings, but more by that change which is the ordinary growth of science—namely, inclusion in some simpler and more general view.

In these advances the chemist has called the spectroscope to his aid. Indeed, the existence of the British Association has been practically coterminous with the comparatively newly developed science of spectrum analysis, for though Newton,* Wol-

* Joannes Marcus Marci, of Kronland in Bohemia, was the only predecessor of Newton who had any knowledge of the formation of a spectrum by a prism. He not only observed that the colored rays diverged as they left the prism, but that a colored ray did not change in color after transmission through a prism. His book, *Thaumantias, liber de arcu caelesti deque colorum apparentium natura*, Prag. 1648, was, however, not known to Newton, and had no influence upon future discoveries.

laston, Fraunhofer and Fox Talbot had worked at the subject long ago, it was not till Kirchhoff and Bunsen set a seal on the prior labors of Stokes, Ångström and Balfour Stewart that the spectra of terrestrial elements were mapped out and grouped; that by its help new elements were discovered, and that the idea was suggested that the various orders of spectra of the same element are due to the existence of the element in different molecular forms—alotropic or otherwise—at different temperatures.

But great as have been the advances of terrestrial chemistry through its assistance, the most stupendous advance which we owe to the spectroscope lies in the celestial direction. In the earlier part of this century, whilst the sidereal universe was accessible to investigators, many problems outside the solar system seemed to be unapproachable.

At the third meeting of the Association, at Cambridge, in 1833, Dr. Whewell said that astronomy is not only the queen of science, but the only perfect science, which was "in so elevated a state of flourishing maturity that all that remained was to determine with the extreme of accuracy the consequences of its rules by the profoundest combinations of mathematics, the magnitude of its data by the minutest scrupulousness of observation."

But in the previous year, viz., 1832, Airy, in his report to the Association on the progress of astronomy, had pointed out that the observations of the planet Uranus could not be united in one elliptic orbit—a remark which turned the attention of Adams to the discovery of Neptune. In his report on the position of optical science in 1832, Brewster suggested that with the assistance of adequate instruments "it would be possible to study the action of the elements of material bodies upon rays of artificial light, and thereby to discover the analogies be-

tween their affinities and those which produce the fixed lines in the spectra of the stars, and thus to study the effects of the combustions which light up the suns of other systems."

This idea has now been realized. All the stars which shine brightly enough to impress an image of the spectrum upon a photographic plate have been classified on a chemical basis. The close connection between stars and nebulae has been demonstrated; and while on the one hand the modern science of thermodynamics has shown that the hypothesis of Kant and Laplace on stellar formation is no longer tenable, inquiry has indicated that the true explanation of stellar evolution is to be found in the gradual condensation of meteoritic particles, thus justifying the suggestions put forward long ago by Lord Kelvin and Prof. Tait.

We now know that the spectra of many of the terrestrial elements in the chromosphere of the sun differ from those familiar to us in our laboratories. We begin to glean the fact that the chromospheric spectra are similar to those indicated by the absorption going on in the hottest stars, and Lockyer has not hesitated to affirm that these facts would indicate that in those localities we are in the presence of the actions of temperatures sufficiently high to break up our chemical elements into finer forms. Other students of these phenomena may not agree in this view, and possibly the discrepancies may be due to default in our terrestrial chemistry. Still, I would recall to you that Dr. Carpenter, in his Presidential Address at Brighton in 1872, almost censured the speculations of Frankland and Lockyer in 1868 for attributing a certain bright line in the spectrum of solar prominences (which was not identifiable with that of any known terrestrial source of light) to a hypothetical new substance which they proposed to call 'helium,' because "it had

not received that verification which, in the case of Crookes' search for thallium, was afforded by the actual discovery of the new metal." Ramsay has now shown that this gas is present in dense minerals on earth; but we have now also learned from Lockyer that it and other associated gases are not only found with hydrogen in the solar chromosphere, but that these gases, with hydrogen, form a large percentage of the atmospheric constituents of some of the hottest stars in the heavens.

The spectroscope has also made us acquainted with the motions and even the velocities of those distant orbs which make up the sidereal universe. It has enabled us to determine that many stars, single to the eye, are really double, and many of the conditions of these strange systems have been revealed. The rate at which matter is moving in solar cyclones and winds is now familiar to us. And I may also add that quite recently this wonderful instrument has enabled Prof. Keeler to verify Clerk Maxwell's theory that the rings of Saturn consist of a marvellous company of separate moons—as it were, a cohort of courtiers revolving round their queen—with velocities proportioned to their distances from the planet.

If we turn to the sciences which are included under physics, the progress has been equally marked. In optical science, in 1831, the theory of emission as contrasted with the undulatory theory of light was still under discussion. Young, who was the first to explain the phenomena due to the interference of the rays of light as a consequence of the theory of waves, and Fresnel, who showed the intensity of light for any relative position of the interference waves, both had only recently passed away.

The investigations into the laws which regulate the conduction and radiation of heat, together with the doctrine of latent and of specific heat, and the relations of

vapor to air, had all tended to the conception of a material heat, or caloric, communicated by an actual flow and emission. It was not till 1834 that improved thermometrical appliances had enabled Forbes and Melloni to establish the polarisation of heat, and thus to lay the foundation of an undulatory theory for heat similar to that which was in progress of acceptance for light.

Whewell's report, in 1832, on magnetism and electricity shows that these branches of science were looked upon as cognate, and that the theory of two opposite electric fluids was generally accepted. In magnetism the investigations of Hansteen, Gauss and Weber in Europe, and the observations made under the Imperial Academy of Russia over the vast extent of that Empire, had established the existence of magnetic poles, and had shown that magnetic disturbances were simultaneous at all the stations of observation.

At their third meeting the Association urged the Government to establish magnetic and meteorological observatories in Great Britain and her colonies and dependencies in different parts of the earth, furnished with proper instruments, constructed on uniform principles, and with provisions for continued observations at those places.

In 1839 the British Association had a large share in inducing the Government to initiate the valuable series of experiments for determining the intensity, the declination, the dip and the periodical variations of the magnetic needle which were carried on for several years, at numerous selected stations over the surface of the globe, under the directions of Sabine and Lefroy.

In England systematic and regular observations are still made at Greenwich, Kew and Stonyhurst. For some years past similar observations by both absolute and self-recording instruments have also been made at Falmouth—close to the home of

Robert Were Fox, whose name is inseparably connected with the early history of terrestrial magnetism in this country; but under such great financial difficulties that the continuance of the work is seriously jeopardised. It is to be hoped that means may be forthcoming to carry it on. Cornishmen, indeed, could find no more fitting memorial of their distinguished countryman, John Couch Adams, than by suitably endowing the magnetic observatory in which he took so lively an interest.

Far more extended observation will be needed before we can hope to have an established theory as to the magnetism of the earth. We are without magnetic observations over a large part of the southern hemisphere. And Prof. Rücker's recent investigations tell us that the earth seems as it were alive with magnetic forces, be they due to electric currents or to variations in the state of magnetised matter; that the disturbances affect not only the diurnal movement of the magnet, but that even the small part of the secular change which has been observed, and which has taken centuries to accomplish, is interfered with by some slower agency. And, what is more important, he tells us that none of these observations stand as yet upon a firm basis, because standard instruments have not been in accord; and much labor, beyond the power of individual effort, has hitherto been required to ascertain whether the relations between them are constant or variable.

In electricity, in 1831, just at the time when the British Association was founded, Faraday's splendid researches in electricity and magnetism at the Royal Institution had begun with his discovery of magneto-electric induction, his investigation of the laws of electro-chemical decomposition, and of the mode of electrolytical action. But the practical application of our electrical knowledge was then limited to the use

of lightning conductors for buildings and ships. Indeed, it may be said that the applications of electricity to the use of man have grown up side by side with the British Association.

One of the first practical applications of Faraday's discoveries was in the deposition of metals and electro-plating, which has developed into a large branch of national industry; and the dissociating effect of the electric arc, for the reduction of ores, and in other processes, is daily obtaining a wider extension.

But probably the application of electricity which is tending to produce the greatest change in our mental and even material condition is the electric telegraph and its sister, the telephone. By their agency not only do we learn, almost at the time of their occurrence, the events which are happening in distant parts of the world, but they are establishing a community of thought and feeling between all the nations of the world which is influencing their attitude towards each other, and, we may hope, may tend to weld them more and more into one family.

The electric telegraph was introduced experimentally in Germany in 1833, two years after the formation of the Association. It was made a commercial success by Cooke and Wheatstone in England, whose first attempts at telegraphy were made on the line from Euston to Camden Town in 1837, and on the line from Paddington to West Drayton in 1838. The submarine telegraph to America, conceived in 1856, became a practical reality in 1866 through the commercial energy of Cyrus Field and Pender, aided by the mechanical skill of Latimer Clark, Gooch and others, and the scientific genius of Lord Kelvin. The knowledge of electricity gained by means of its application to the telegraph largely assisted the extension of its utility in other directions.

The electric light gives, in its incandes-

cent form, a very perfect hygienic light. Where rivers are at hand the electrical transmission of power will drive railway trains and factories economically, and might enable each artisan to convert his room into a workshop, and thus assist in restoring to the laboring man some of the individuality which the factory has tended to destroy. In 1843 Joule described his experiments for determining the mechanical equivalent of heat. But it was not until the meeting at Oxford, in 1847, that he fully developed the law of the conservation of energy, which, in conjunction with Newton's law of the conservation of momentum, and Dalton's law of the conservation of chemical elements, constitutes a complete mechanical foundation for physical science.

Who, at the foundation of the Association, would have believed some far-seeing philosopher if he had foretold that the spectroscopist would analyze the constituents of the sun and measure the motions of the stars; that we should liquefy air and utilize temperatures approaching to the absolute zero for experimental research; that, like the magician in the 'Arabian Nights,' we should annihilate distance by means of the electric telegraph and the telephone; that we should illuminate our largest buildings instantaneously, with the clearness of day, by means of the electric current; that by the electric transmission of power we should be able to utilize the Falls of Niagara to work factories at distant places; that we should extract metals from the crust of the earth by the same electrical agency to which, in some cases, their deposition has been attributed?

These discoveries and their applications have been brought to their present condition by the researches of a long line of scientific explorers, such as Dalton, Joule, Maxwell, Helmholtz, Herz, Kelvin and Rayleigh, aided by vast strides made in me-

chanical skill. But what will our successors be discussing sixty years hence? How little do we yet know of the vibrations which communicate light and heat! Far as we have advanced in the application of electricity to the uses of life, we know but little even yet of its real nature. We are only on the threshold of the knowledge of molecular action, or of the constitution of the all-pervading ether. Newton, at the end of the seventeenth century, in his preface to the 'Principia,' says: "I have deduced the motions of the planets by mathematical reasoning from forces; and I would that we could derive the other phenomena of nature from mechanical principles by the same mode of reasoning. For many things move me, so that I somewhat suspect that all such may depend on certain forces by which the particles of bodies, through causes not yet known, are either urged towards each other according to regular figures, or are repelled and recede from each other; and these forces being unknown, philosophers have hitherto made their attempts on nature in vain."

In 1848 Faraday remarked: "How rapidly the knowledge of molecular forces grows upon us, and how strikingly every investigation tends to develop more and more their importance. A few years ago magnetism was an occult force, affecting only a few bodies; now it is found to influence all bodies, and to possess the most intimate relation with electricity, heat, chemical action, light, crystallization; and through it the forces concerned in cohesion. We may feel encouraged to continuous labors, hoping to bring it into a bond of union with gravity itself."

But it is only within the last few years that we have begun to realize that electricity is closely connected with the vibrations which cause heat and light, and which seem to pervade all space—vibrations which may be termed the voice of the

Creator calling to each atom and to each cell of protoplasm to fall into its ordained position, each, as it were, a musical note in the harmonious symphony which we call the universe.

At the first meeting, in 1831, Prof. James D. Forbes was requested to draw up a report on the State of Meteorological Science, on the ground that this science is more in want than any other of that systematic direction which it is one great object of the Association to give. Prof. Forbes made his first report in 1832, and a subsequent report in 1840. The systematic records now kept in various parts of the world of barometric pressure, of solar heat, of the temperature and physical conditions of the atmosphere at various altitudes, of the heat of the ground at various depths, of the rainfall, of the prevalence of winds, and the gradual elucidation not only of the laws which regulate the movements of cyclones and storms, but of the influences which are exercised by the sun and by electricity and magnetism, not only upon atmospheric conditions, but upon health and vitality, are gradually approximating meteorology to the position of an exact science.

England took the lead in rainfall observations. Mr. G. J. Symons organized the British Rainfall System in 1860 with 178 observers, a system which until 1876 received the help of the British Association. Now Mr. Symons himself conducts it, assisted by more than 3000 observers, and these volunteers not only make the observations, but defray the expense of their reduction and publication. In foreign countries this work is done by government officers at the public cost. At the present time a very large number of rain gauges are in daily use throughout the world. The British Islands have more than 3000, and India and the United States have nearly as many; France and Germany are not far behind; Australia probably has more—in-

deed, one colony alone, New South Wales, has more than 1100.

The storm warnings now issued under the excellent systematic organization of the Meteorological Committee may be said to have had their origin in the terrible storm which broke over the Black Sea during the Crimean War, on November 27, 1855. Leverrier traced the progress of that storm, and seeing how its path could have been reported in advance by the electric telegraph, he proposed to establish observing stations which should report to the coasts the probability of the occurrence of a storm. Leverrier communicated with Airy, and the government authorized Admiral Fitz Roy to make tentative arrangements in this country. The idea was also adopted on the continent, and now there are few civilized countries north or south of the equator without a system of storm warning.*

(To be concluded.)

ELECTRIFICATION AND DISELECTRIFICATION OF AIR AND OTHER GASES.†

§ 1. EXPERIMENTS were made for the purpose of finding an approximation to the amount of electrification communicated to air by one or more electrified needle points. The apparatus consisted of a metallic can 48 cms. high and 21 cms. in diameter, supported by paraffine blocks, and connected to one pair of quadrants of a quadrant electrometer. It had a hole at the top to admit the electrifying wire, which was 5.31 metres long, hanging vertically within a

* It has often been supposed that Leverrier was also the first to issue a daily weather map, but that was not the case, for in the Great Exhibition of 1851 the Electric Telegraph Company sold daily weather maps, copies of which are still in existence, and the data for them were, it is believed, obtained by Mr. James Glaisher, F. R. S., at that time Superintendent of the Meteorological Department at Greenwich.

† Abstract of a paper by Lord Kelvin, Magnus Maclean and Alexander Galt, read before the British Association for the Advancement of Science.

metallic guard tube. This guard tube was always metallically connected to the other pair of quadrants of the electrometer and to its case, and to a metallic screen surrounding it. This prevented any external influences from sensibly affecting the electrometer, such as the working of the electric machine which stood on a shelf 5 metres above it.

some minutes, so as to electrify the air in the can. As soon as the machine is stopped the electrifying wire is lifted clear out of the can. The can and the quadrants in metallic connection with it are disconnected from the case of the electrometer, and the electrified air is very rapidly drawn away from the can by a blowpipe bellows arranged to suck. This releases the opposite

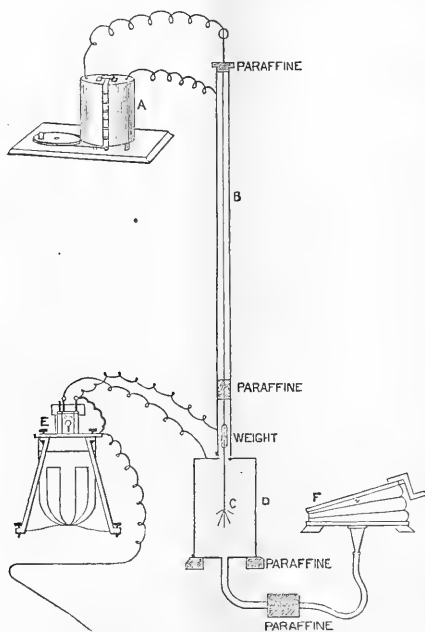

FIG. 1.—Connected with guard screen (not shown in diagram).

§ 2. The experiment is conducted as follows: One terminal of an electric machine is connected with the guard tube and the other with the electrifying wire, which is let down so that the needle is in the centre of the can. The can is temporarily connected to the case of the electrometer. The electric machine is then worked for

kind of electricity from the inside of the can, and allows it to place itself in equilibrium on the outside of the can and on the insulated quadrants of the electrometer in metallic connection with it.

§ 3. We tried different lengths of time of electrification and different numbers of needles and tinsel, but we found that one nee-

dle and four minutes of electrification gave nearly maximum effect. The greatest deflection observed was 936 scale divisions. To find, from this reading, the electric density of the air in the can, we took a metallic disk, of 2 cms. radius, attached to a long varnished glass rod, and placed it at a distance of 1.45 cm. from another and larger metallic disk. This small air condenser was charged from the electric light conductors in the laboratory to a difference of potential amounting to 100 volts. The insulated disk thus charged was removed and laid upon the roof of the large insulated can. This addition to the metal in connection with it does not sensibly influence its electrostatic capacity. The deflection observed was 122 scale divisions. The capacity of the condenser is approximately

$$\frac{\pi \times 2^2}{4\pi \times 1.45} = \frac{1}{1.45}.$$

The quantity of electricity with which it was charged was

$$\frac{1}{1.45} \times \frac{100}{300} = \frac{1}{4.35}$$

electrostatic unit. Hence, the quantity to give 936 scale divisions was

$$\frac{1}{4.35} \times \frac{936}{122} = 1.7637.$$

The bellows was worked vigorously for two and a-half minutes, and in that time all the electrified air would be exhausted. The capacity of the can was 16,632 cubic centimetres, which gives, for the quantity of electricity per cubic centimetre,

$$\frac{1.7637}{16,632} = 1.06 \times 10^{-4}.$$

The electrification of the air in this case was positive; it was about as great as the greatest we got, whether positive or negative, in common air when we electrified it by discharge from needle points. This is about four times the electric density which

we roughly estimated as about the greatest given to the air in the inside of a large metal vat, electrified by a needle point and then left to itself, and tested by the potential of a water dropper with its nozzle in the centre of the vat, in experiments made two years ago and described in a communication to the Royal Society of date May, 1894.*

§ 4. In subsequent experiments, electrifying common air in a large gasholder over water by an insulated gas flame burning within it with a wire in the interior of the flame kept electrified by an electric machine to about 6,000 volts, whether positively or negatively, we found as much as 1.5×10^{-4} for the electric density of the air. Electrifying carbonic acid in the same gasholder, *whether positively or negatively*, by needle points, we obtained an electric density of 2.2×10^{-4} .

§ 5. We found about the same electric density (2.2×10^{-4}) of *negative* electricity in carbonic acid gas drawn from an iron cylinder lying horizontally, and allowed to pass by a U-tube into the gasholder without bubbling through the water. This electrification was due probably not to carbonic acid gas rushing through the stopcock of the cylinder, but to bubbling from the liquid carbonic in its interior, or to the formation of carbonic acid snow in the passages and its subsequent evaporation. When carbonic acid gas was drawn slowly from the liquid carbonic acid in the iron cylinder placed upright, and allowed to pass, without bubbling, through the U-tube into the gasholder over water, no electrification was found in the gas unless electricity was communicated to it from needle points.

§ 6. The electrifications of air and carbonic acid described in Sections 4 and 5 were tested, and their electric densities measured by drawing by an air pump a

* 'On the Electrification of Air,' by Lord Kelvin and Magnus Maclean.

measured quantity of the gas* from the gasholder through an India-rubber tube to a receiver of known efficiency and of known capacity in connection with the electrometer. We have not yet measured how much electricity was lost in the passage through the India-rubber tube. It was not probably nothing; and the electric density of the gas before leaving the gasholder was no doubt greater, though perhaps not much greater, than what it had when it reached the electric receiver.

§ 7. The efficiency of the electric receivers used was approximately determined by putting two of them in series, with a paraffine tunnel between them, and measuring by

in each case. This assumption was approximately justified by the results.

§ 8. Thus we found for the efficiencies of two different receivers respectively 0.77 and 0.31 with air electrified positively or negatively by needle points; and 0.82 and 0.42 with carbonic acid gas electrified negatively by being drawn from an iron cylinder placed on its side. Each of these receivers consisted of block tin pipe, 4 cms. long and 1 cm. diameter, with 5 plugs of cotton wool kept in position by six discs of fine wire gauze. The great difference in their efficiency was no doubt due to the quantities of cotton wool being different, or differently compressed in the two.

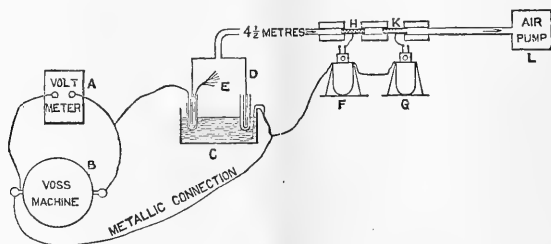

FIG. 2.

means of two quadrant electrometers the quantity of electricity which each took from a measured quantity of air drawn through them. By performing this experiment several times, with the order of the two receivers alternately reversed, we had data for calculating the proportion of the electricity taken by each receiver from the air entering it, on the assumption that the proportion taken by each receiver was the same

* The gasholder was 38 cms. high and 81 cms. in circumference. Ten strokes of the pump raised the water inside to a height of 8.1 cms., so that the volume of air drawn through the receivers in the experiments was 428 cubic centimetres per stroke of the pump. This agrees with the measured effective volume of the two cylinders of the pump.

§ 9. We have commenced and we hope to continue an investigation of the efficiency of electric receivers of various kinds, such as block tin, brass and platinum tubes from 2 to 4 cms. long, and from 1 mm. to 1 cm. internal diameter, all of smooth bore and without any cotton wool or wire gauze filters in them; also a polished metal solid, insulated within a paraffine tunnel. This investigation, made with various quantities of air drawn through per second, has already given us some interesting and surprising results, which we hope to describe after we have learned more by farther experimenting.

§ 10. In addition to our experiments on

electric filters we have made many other experiments to find other means for the dis-electrification of air. It might be supposed that drawing air in bubbles through water should be very effective for this purpose, but we find that this is far from being the case. We had previously found that non-electrified air drawn in bubbles through pure water becomes negatively electrified, and through salt water positively. We now find that positively electrified air drawn through pure water, and negatively electrified air through salt water, has its electrification diminished but not annulled, if the primitive electrification is sufficiently strong. Negatively electrified air drawn in bubbles through pure water, or positively electrified air drawn through salt water, has its electrification augmented.

§ 11. To test the effects of heat we drew air through combustion tubes of German glass about 180 cms. long, and $2\frac{1}{2}$ or $1\frac{1}{2}$ cms. bore, the heat being applied externally to about 120 cms. of the length. We found that, when the temperature was raised to nearly a dull red heat, air, whether positively or negatively electrified, lost little or nothing of its electrification by being drawn through the tube. When the temperature was raised to a dull red heat, and to a bright red, high enough to soften the glass, losses up to as much as four-fifths of the whole electrification were sometimes observed, but never complete diselectrification. The results, however, were very irregular. Non-electrified air never became sensibly electrified by being drawn through the hot glass tubes in our experiments, but it gained strong positive electrification when pieces of copper foil, and negative electrification when pieces of carbon, were placed in the tube, and when the temperature was sufficient to powerfully oxidize the copper or to burn away the charcoal.

§ 12. Through the kindness of Mr. E.

Matthey, we have been able to experiment with a platinum tube 1 metre long and 1 millimetre bore. It was heated either by a gas flame or an electric current. When the tube was cold, and non-electrified air drawn through it, we found no signs of electrification by our receiver and electrometer. But when the tube was made red or white hot, either by gas burners applied externally or by an electric current through the metal of the tube, the previously non-electrified air drawn through it was found to be electrified strongly positive. To get complete command of the temperature we passed a measured electric current through 20 centimetres of the platinum tube. On increasing the current till the tube began to be at a scarcely visible dull red heat we found but little electrification of the air. When the tube was a little warmer, so as to be quite visibly red hot, large electrification became manifest. Thus 60 strokes of the air pump gave 45 scale divisions on the electrometer when the tube was dull red, and 395 scale divisions (7 volts) when it was a bright red (produced by a current of 36 ampères). With stronger currents, raising the tube to white-hot temperature, the electrification seemed to be considerably less.

SCIENCE OR POETRY.

THE hardest of intellectual virtues is philosophic doubt, and the mental vice to which we are most prone is our tendency to assume that lack of evidence for an opinion is a reason for believing something else.

This tendency has value in practical matters which call for action, but the man of science need neither starve nor choose, and suspended judgment is the greatest triumph of intellectual discipline, although vacillation brands the man of affairs with weakness.

Anything which is conceivable may be

good poetry, but science is founded upon the rock of evidence, and we all believe many things which are inconceivable, such as the truth that the image in our eyes is upside down, and we justly repudiate many opinions which are not only quite conceivable but also quite incapable of disproof.

Many persons have found the opinion that all nature is conscious and endowed with volition, that the morning stars sing together, that the waters laugh, that the wind bloweth where it listeth, and that trees talk; not only conceivable but worthy of belief, and it is quite clear that we cannot oppose any belief of this sort, or convert the sailor who believes the wind obeys his whistle, by evidence.

The path of scientific progress is strewn with beliefs which have been abandoned from lack of evidence, as burst shells strew a battlefield, and it is our boast that they are abandoned and not lugged along the line of march.

As a shell which has failed to burst is now and then picked up on some old battlefield by some one on whom experience is thrown away, and is exploded by him with disastrous results in the bosom of his approving family, so one of these abandoned beliefs is sometimes dug up by the head of some scientific family to the intellectual confusion of those who accept him as their leader.

We need not concern ourselves with the beliefs of the unscientific, but the utterances of the heads of learned societies are public acts, approved by the majority of the members. They come before the public with authority, and they are regarded by the world as the expressions of the mature judgment of American men of science.

In a recent number of SCIENCE (p. 210) a 'President' quotes the opinion 'of a chemist, a physicist and a biologist,' to the effect that they cannot conceive how the problems of biology are to be referred to

mechanical energy and physical matter; and he tells us furthermore that "it can be stated without fear of refutation that every physiological investigation shows with accumulating emphasis that the manifestations of living matter are not explicable only with the forces of dead matter."

The assertion that this is shown by every or by any physiological investigation is flatly contradicted by most of the investigators; but the assertion that *it can be stated without fear of refutation that so and so is true* is a pretty safe one, although a moment's reflection will show that there is no end to the things which may be stated without fear of refutation; that Mars is inhabited, for example, or that we are surrounded by good and evil spirits.

Another recent number of SCIENCE (p. 125) contains the statement, by one who is many times a President, that when protozoa move towards the light they 'seek' oxygen, and that in order to 'seek' it "they have to be aware that they need it, and must have some knowledge of the fact when they get it."

When we ask how the President knows all this we receive this most remarkable and characteristic answer: "It is impossible at present to *assign any other cause* to some of the movements of even the amœba."

A child can see that lack of proof is not evidence, and while it is impossible to prove that an amœba or an oak tree is not conscious and is not endowed with volition, the statement that they are so endowed is not science but poetry until some better evidence than lack of proof is adduced.

Even if positive evidence were found, even if it were proved that all nature is conscious, this would not be proof that consciousness and volition are or can be causes of structure.

If we admit, as I think we must, that, for all we know, an oak tree may have volition and may do as it likes, what evidence

is there that it ever likes to do anything which it would not do in any case, by virtue of its structure, even if it were unconscious?

If the President will give us evidence that volition is an agent in this sense of the word; that it can do anything which is not deducible from structure; that it can be a cause of structure; that any one by taking thought can add one cubit to his stature; I, for one, will hold him in the highest honor as the greatest of discoverers; nor do I believe that he will find me prejudiced, for I trust that I have done all that in me lies to refrain from preconception, and I simply want to know.

"If he possesses such knowledge he is just the man for whom I have long been seeking. All knowledge can be communicated, and therefore I might hope to see my own knowledge increased to this prodigious amount by his instruction." (Kant; translated by Huxley; *Hume*, p. 208.)

If the learned bodies which give their allegiance to the utterances I have quoted will publish the evidence which proves that consciousness and volition can cause structure or anything else, they will not only demonstrate their own scientific eminence, but, by settling a question which has never ceased to vex the mind of man, they will make the closing years of the nineteenth century memorable for all time by the greatest scientific discovery the world has seen.

In an article which was printed in SCIENCE in April, 1895, I urged the need for philosophic doubt on the problems of life, and I also took occasion to affirm my own opinion that the phenomena of vitality and of volition are so peculiar that these words are most useful ones in so much as they help to focus the most distinctive problems of biology.

I thought I had made it clear that my plea for these words is based on their value in helping us to keep difficulties in clear view

and not because they explain anything; and I have been much surprised by the receipt of a number of letters from Vitalists who welcome me as a new recruit.

No one likes to march alone; and both sides put the man who does not take sides with the enemy. We need all the comrades we can get in our weary way through life, and I regret the necessity which forces me to tell my correspondents I cannot fight under their banner; and that my only purpose in writing the article was to show that intolerance has followed the conversion into a belief, by pious Monists, of Huxley's carefully guarded declaration that he lives '*in the hope and in the faith*' that we shall some time be able to see our way from the constituents of living matter to its properties.

Nothing was farther from my thoughts than any dogmatic assertion that vitality and volition are outside the domain of physical matter and mechanical energy, or that they are agents, and I had in mind certain zoölogists who seem to me to be attempting to discount the possibilities of future discovery in defiance of the warning "that the assertion which outstrips evidence is not only a blunder but a crime."

Recent utterances seem to show that all the criminals are not among the materialists, and that the dogmatism of biologists must be attacked at both ends of the line.

In all seriousness we ask, what can fundamental disagreement among those who speak with authority lead to, except disaster? Are we not bound to find first principles which will command the assent of all thinking men?

Those who hold the creed that all the activities of animals and plants will some day be deduced from the properties of the physical basis of life are not likely to be influenced by any other opinion of the matter, whether this be called a belief, a hope or a working hypothesis; nor are those who hold that our will is free at all persuaded by those

who assert that volition is only an empty shadow of the changes which go on in the physical basis. So far as I can see, there can be no compromise between these opinions; and the *modus vivendi* is a device of the men of affairs, with which science has no concern.

Science still has many acute and well-trained enemies, and if they should concentrate their forces in an attack upon biology what better weapon could we place in their hands than our own failure to agree?

Honesty of purpose and expediency unite in the demand that we build biology upon a foundation which can never be shaken; and if we accept as our creed the assertion that while we do not know whether life is or is not different from matter, that while we do not know whether thought is or is not an agent, we should like to find out, we need fear no attack by anything in the universe or outside it.

I am tempted to add a word of comment on one of my letters, as it bears upon the case in point, and is a good illustration of a belief which is held because it cannot be disproved.

It is accompanied by a book in which the writer devotes literary training and skill which many a scientific writer might envy, and eloquence and enthusiasm worthy of any cause, to the thesis that the living world is the work of 'Biologos,' a being who is said to bear about the same relation to us as that which we bear to the plants which we cherish in our gardens from love of horticulture; a being who is very paternal, very loving, very sympathetic and very superhuman, but still very far short of omniscience or omniscience.

The writer seems to forget that there is no new thing under the sun, and that ages ago the first of naturalists failed to secure appointment as successor to the head of a school where very similar views had been taught, on account of his refusal to advocate

them, not because he thought he could disprove them, but because he held that they are not supported by evidence.

W. K. BROOKS.

JOHNS HOPKINS UNIVERSITY.

*BIBLIOGRAPHY AS A FEATURE OF THE CHEMICAL CURRICULUM.**

WHEN the Chairman of the Committee on Didactic Chemistry sent me a flattering invitation to address the Chemical Section on some topic associating bibliography with instruction, I hesitated to accept, for it seemed to me that the matter was too obvious to require discussion; but later, as chairman of a committee whose duty it is to encourage, in every possible way and on all occasions, the indexing of chemical literature, I concluded it was my duty to seize the opportunity of saying a few words in favor of introducing bibliographical research into the chemical curriculum of our American colleges. Could this be generally done what a multitude of chemical indexes to special topics might be secured!

The matter is largely in the hands of the heads of the chemical departments in our institutions of learning. As in every branch of instruction, in order to impart to students a lively interest in the subject, the teacher should himself have practical experience in the approved methods of indexing. He might introduce the subject by a lecture on Chemical Literature, pointing out the most recent and the most useful books and serials in the several branches of the science, their special and relative values, and the best way to use them. The teacher might exhibit a sample index in MS., prepared on the index cards of the Library Bureau, and he might explain to those unfamiliar with library cataloguing the technical methods employed. He might also discuss the different ways of

*Read to the Chemical Section of the American Association for the Advancement of Science, Springfield Meeting, August, 1895.

classifying and grouping the data, and show the advantages and disadvantages of the chronological, the author-alphabetical and the topical arrangements. Quite early in the instruction the teacher should direct the attention of the students to the necessity of discrimination between catalogues, bibliographies and indexes, for these words are too often used either as synonyms or indifferently. He should inform the students that a *catalogue* is a list of books on all subjects in a certain collection or locality; that a *bibliography* is a list of the books on a given subject without regard to their position; and that an *index* is a systematically arranged list of the papers and researches on a definite topic contained in books and serials, with references to the same. The teacher might warn the students against regarding the compilation of indexes as drudgery, claiming on the contrary that the task involves an agreeable pursuit similar in its fascination to that of the hunter.

The best methods for securing intelligent work in bibliography may well be left to the judgment of those having charge of instruction. I merely suggest that some institutions find it feasible to require of candidates for the higher degrees in science (B. S., S. D. and Ph. D.) chemical dissertations accompanied by special indexes to the literature of the subjects under discussion. This is a part of the prescribed work for applicants for the degree of Ph. D. at the Corcoran Scientific School of The Columbian University, Washington, a distinction of which the Dean may be justly proud. The preparation of Indexes to Chemical Literature is also required of undergraduates at the University of Michigan by the professor in charge, who is himself a member of the committee of the American Association for the Advancement of Science, already referred to. As a specimen of the excellent work done under Professor Pres-

cott's direction, I may mention the 'Bibliography of Aceto-Acetic Ester,' by Paul H. Seymour, which has been honored by publication in the Miscellaneous Collections of the Smithsonian Institution. (No. 970, Washington, 1894, 148 pp., 8°.) A similar requirement is in force in the chemical departments of Cornell University and of the University of Cincinnati.

The amount and kind of bibliographical work to be required of students will unavoidably vary greatly in different institutions, and must depend in part on the extent of the libraries to which the students have access and in part on their linguistic capacities. In many cases it might be well to limit the requirements to works in the English language, or even to the publications of American chemists, but if thus restricted, completeness within these limits should be insisted upon.

The problem of getting these undergraduate indexes into print is a somewhat difficult one; obviously many would of necessity remain in MS. on the shelves of the college library and become available to a very small number. Some of the more carefully prepared indexes to topics of prime importance would always find channels of publication either in the serials issued by learned societies, in periodicals devoted to analogous subjects, or through the higher medium of the Smithsonian Institution. This difficulty vanishes, however, with respect to those universities that require candidates for higher degrees to *print* their dissertations, as is the custom in most countries of Europe. The U. S. Bureau of Education has furnished me with the following:

**List of Universities and Colleges which require Printed Dissertations before (or after) conferring the degree of Ph. D.:* Clark University, Worcester, Mass.; College of New Jersey,

**Additions and corrections are earnestly desired by the writer.*

Princeton, N. J.; Columbia College, New York City; Cornell University, Ithaca, N. Y.; Johns Hopkins University, Baltimore, Md.; Lake Forest University, Lake Forest, Ill.; Leland Stanford, Jr., University, California; Northwestern University, Evanston, Ill.; University of Colorado, Boulder, Colo.; University of Chicago, Chicago, Ill.; University of Indiana, Bloomington, Ind.; University of Kansas, Lawrence, Kan.; University of Michigan, Ann Arbor, Mich.; University of Minnesota, Minneapolis, Minn.; University of Virginia, Charlottesville, Va.; University of Wisconsin, Madison, Wis.; Vanderbilt University, Nashville, Tenn.; Western Reserve University, Cleveland, Ohio.

Allow me to call attention, in this connection, to the desirability of forming a complete collection of all printed dissertations of American universities, and to suggest that the Smithsonian Institution is the proper place of deposit for such a collection. The Institution already receives those issued by the John Hopkins University and is willing to give others a place. When the magnificent new Library of Congress is completed, a collection of American university dissertations could be well housed, and would make a really valuable addition to the treasury of books; eventually a catalogue of these works could be published, as has recently been done in France. (Catalogue des Thèses de Sciences, 1810-1890, Albert Maire, Paris, 1892; Catalogue des Thèses de Pharmacie à l'École de Pharmacie de Paris, 1815-1889, Paul Dorveaux, Paris, 1891; Catalogue des Thèses de Pharmacie soutenues en Province, 1803-1894, Paul Dorveaux, Paris, 1895). It may be proper to state that I am attempting to catalogue all the printed chemical dissertations of American colleges for the *Supplement* to my 'Select Bibliography of Chemistry,' and I appeal to the members of the Chemical Section for assistance.

Finally, could bibliographical researches be introduced into the chemical curriculum of American colleges several advantages would ensue beyond the mere collection of indexes; such a procedure would train students to accuracy in making citations; it would encourage in them a disposition to give credit to earlier workers in the same field of research as their own; it would tend to enlarge their views as to the immense domain of chemical literature; it would lay foundations upon which the post-graduates might build more substantially in after years, and it would develop an appreciation of the historical aspects of chemistry, which busy workers in the laboratory too rarely have opportunities of cultivating.

H. CARRINGTON BOLTON.

AGRICULTURAL CHEMISTRY.*

AGRICULTURAL chemistry is a cosmopolitan science. It was founded by Liebig, of immortal memory. Its early apostle in France was Boussingault; in England, Gilbert; in America, Johnson. It is presumably that science most nearly allied to the sustenance of human life, and thus lies nearer than any other to the heart, or perhaps the stomach, of humanity. Its home is wherever a plant grows. Its devotees are found wherever a plowshare turns the soil. Its base lies in the study of the composition of the soil and the constitution of plants. Its superstructure rises high enough to touch the most abstruse questions of mineral and vegetable physiology and metabolism. Turning from philosophy to facts, we find this science linked indissolubly with the greatest industry of the world. There is scarcely a field or a forest which has not felt the impress of its power. From the field its domain has extended to the factory and the guidance and advice of the

* Read before Section of Chemistry of the American Association for the Advancement of Science, September 3, 1895.

chemist are sought for the further preparation of foods and fabrics for the use of man. It has also secured a place in the domain of public and advanced instruction, and even the conservatism of the great universities has yielded to agricultural chemistry a prominent place in the curriculum of studies. Both in this country and in Europe hundreds of special schools and experiment stations are found devoted largely to the service of agricultural chemistry and its coördinate branches of science.

The art of fertilizing the fields, at first purely empirical, has become an exact science. The methods of saving and recovering waste fertilizing products, at the present time, renders many great industries possible which otherwise would have to yield to the fierce competition which every human endeavor has to meet at this end of the century. Further than this the paternal efforts of agricultural chemistry extend and seek to recover from the mine and from the sea the elements of fertility apparently forever lost during the centuries that have passed.

The science of agricultural chemistry acknowledges, without stint, its indebtedness to the other fields of chemical work. In its very beginning it was the simple use of the principles of mineral analysis, applied to the soil and its products. By this means the parts of the plants which were derived directly from the soil were determined, and the surprising fact was thus developed that nearly the whole of the vast product of vegetable growth is a free gift of Heaven and not chargeable to the soil. This was the point of union between agricultural chemistry and meteorology, and the basis of the science of meteorology applied to agriculture. The supply of carbon dioxide and water to the growing plant becomes thus a problem of the profoundest interest to agriculture, and the chemist and physicist have thus been led to study the great problems of precipitation, drainage and

irrigation as affecting the products of the field. The best methods of disposing of an excess of rainfall, with the minimum loss of plant food due to percolation of water through the soil, are of no less importance. In connection with this, that treatment of the soil by chemical and physical means which will best prepare it to distribute the supply of moisture available to the advantage of the growing plant has been carefully studied.

Agricultural science has also drawn freely on the resources of organic chemistry. In agricultural products are presented to the students some of the most complicated as well as interesting organic compounds. In the growth of the plant are seen the wonderful resources of the vegetable cell in the way of chemical activity. The most renowned achievements of modern synthetic chemistry have consisted in the reproduction of some of the simpler forms of vegetable organic compounds. It will be admitted, without doubt, that the simple sugars are the least complicated of organic vegetable products, and these have been at last successfully made in the laboratory. The step from a hexose to a hexobiose seems indeed a short one, and yet it has not been taken. Only step by step must we expect the onward progress of synthesis until, for instance, a starch is reached. Yet in the progress of organic synthetic chemistry already accomplished, great good has come. The exact chemical relations of the sugars to the aldehyds, ketones and polyatomic alcohols have been established and the bonds which unite the organic chemistry of man to that of Nature clearly distinguished. On a former occasion, in an address to the Chemical Society, I have pointed out the futility of the expectation that synthetic organic chemistry will ever be able to take the place of agriculture, but the debt agriculture owes it is one of great and constantly increasing magnitude.

Not of less practical importance to agriculture has been the recent progress in our knowledge of that indefinite complex which has so long passed under the misnomer of 'nitrogen-free extract.' With the exception of the facts that it is not nitrogen-free and that it is not an extract, the name may do well enough. At least some agricultural chemists have an idea of what the term signifies, and to others it serves the purpose of the physician's malaria, permitting them to designate, in a fairly mysterious way, a something of which nothing is known. The constitution of the greater part of this complex body is now known, and the proportions of cellulose and of pentosans which it contains can be determined with a fair degree of definiteness. We should deem it a matter for congratulation to be assured that the day is fast approaching when the agricultural chemist will no longer be called on to determine forty per cent. or more of a cattle food 'by difference.'

In late years not only has organic chemistry helped us in the way of a better understanding of the composition of the carbohydrates, but it has also pointed out to us some of the main points in the constitution of those most valuable products, the vegetable proteids. We are far behind our digestive organs in our understanding of these bodies and have been accustomed in practical work to place all proteid matter together in a single class. But there is no doubt of the fact that the vegetable proteids differ as much among themselves as those of animal origin, and at last the chemist is able to distinguish between them. Even if it should prove that there is little difference in their food value, yet it must be conceded that a knowledge of their structural differences, together with the several contents of nitrogen found therein, will prove in the end of the greatest advantage to the agricultural chemist.

The relations of agriculture to pedagogic

chemistry have already been mentioned. In many of our public schools it is thought to be quite as important to teach the child something about the life of the field and the orchard as to drill him in the geography of Johore. How plants and animals grow is a theme which will one day be developed in every school in the land. Naturally, in agricultural colleges, the pedagogic side of agricultural chemistry receives due consideration, but alas! with these institutions it is sometimes *nomen et preterea nihil*. In these cases agricultural chemistry must often give place to a heterochronistic psychology. But, on other hand, many of our universities have recognized the need of such instruction and have provided properly therefor. Merely material considerations should induce all our higher institutions of learning to provide for advanced instruction in agricultural chemistry, for just now there is, and for years to come there will be, a large demand for young men well trained in this direction. It will not be many years before it will be required of every well-equipped university to provide liberally for the professional education of the young men who are to take charge of the agricultural colleges and experiment stations of the country.

In its relations to bacteriology, agricultural chemistry is also a debtor. In the life history of those minute vegetable organisms which exert so profound a chemical action on many bodies has been found the solution of the problem of those fermentations which prepare for use the nitrogenous foods of plants. The successive conversion of organized nitrogen into ammonia, nitrous and nitric acids is a process of the most vital importance to plant life. It is true that these activities were exerted for several millions of years without our knowing anything about them, and they would doubtless go on until the end of time if our knowledge of them should entirely

cease and determine. Nevertheless, the value of what little knowledge we now possess seems almost the groundwork of scientific agriculture. The micro-organisms which nitrify organic nitrogenous compounds, as well as those which act in the opposite direction, viz., in reducing nitrates to a lower form of oxidation, are of the utmost importance to agricultural chemistry. It is not beyond the range of possibility that a barren field may be rendered fertile by securing conditions favorable to nitrification and then seeding the soil with a few active nitrifying ferments.

Quite true it is, already, that any scheme for an analysis of a soil which leaves out of consideration the determination of nitrifying activity is far from complete. The action of bacteria on the ripening of cream and of cheese is a matter of but little importance. The fermentation of cream and of cheese is already as much of an art as the fermentation of malt in the manufacture of beer. In the curing of tobacco the same activity is discovered and the day is not far distant when commerce in high bred tobacco bacteria will be an established fact. In short, we may look forward to the day when the bacteria active in agriculture will be carefully cultivated and the bacterial herd book will be found along with those of the Jersey cow and the Norman horse. Agricultural chemistry makes demands on every science which can aid it in the production of food and in the advancement of rational agriculture.

But we may go still a step further and follow the crude food into the factory and the kitchen. From the knowledge of the action of ferments mentioned above the great art of food preservation has been created. The sterilization of food products and their preservation from the further action of destructive ferments is one of the practical developments of rational agricultural chemistry. This method of food preservation is

infinitely preferable to that other simpler process which consists in adding to the food a substance which paralyzes the further action of micro-organisms. Happily, agricultural and analytical chemistry have provided a certain method of detecting chemicals thus used for food preservation.

The conversion of foods into appropriate digestive forms and the study of their nutritive power mark the final step in agricultural chemistry in its control of food products. In this relation it comes into intimate contact with hygiene and animal physiology, thus almost completing the circle of intimate union with nearly all the leading sciences. Intimately associated with this branch of the subject is the control of the purity of the food itself and the detection of the adulterations to which it may be subjected.

The thoughts suggested in the foregoing pages are those that have come to me amid a multitude of distractions as those suited, at least in part, to meet the views of your presiding officer in asking me to introduce the theme of agricultural chemistry for discussion before the Section. I now yield the floor for a more particular treatment of some of the branches of the subject.

H. W. WILEY.

PROCEEDINGS OF THE BOTANICAL CLUB, A. A. S., SPRINGFIELD MEETING, AUGUST 29th TO SEPTEMBER 2d, 1895.

THE meetings were held in the room assigned to Section 'G,' in the State Street Baptist Church.

THURSDAY MORNING, AUGUST 29.

In the absence of the President, Prof. D. H. Campbell, and of the Secretary, Prof. F. C. Newcombe, the meetings of the Club were placed in organization by Prof. Geo. F. Atkinson. Hon. David F. Day was made Chairman *pro tem.*, and Prof. H. L. Bolley, Secretary.

On motion of Professor Atkinson, those having papers to present were requested to hand titles of the same to the Secretary upon the day preceding that upon which it was wished the paper should be read.

The meeting adjourned at 11:30 to meet at 9 A. M., Friday, August 30th.

FRIDAY MORNING, AUGUST 30.

The Club met as ordered, with President D. H. Campbell in the chair. In order to facilitate the reading of papers, the titles of which for the first time in the history of the Club now appeared printed in the regular daily program of the A. A. A. S., the reading of the minutes of the previous meetings was dispensed with.

The first paper presented was on 'Crimson Clover Hairballs,' by Mr. F. V. Coville. These balls, composed of the hairs of the Crimson Clover, *Trifolium incarnatum*, has been found in the stomach of a horse. Mr. Coville exhibited specimens, also mounted slides showing their composition.

Professor Byron D. Halsted reported the results of field experiments with beans. He had found that 25 per cent. of plants grown on soil previously occupied by beans were affected by spot, whereas when grown on new soil only six per cent. were diseased.

Mrs. Elizabeth G. Britton reported corrections upon descriptions of *Coscinodon*.

Mr. O. F. Cook remarked upon 'A Peculiar Habit of a Liberian Species of *Polyporus*,' and exhibited specimens showing various degrees of proliferation, one pileus arising from another upon very extended delicate stalks, due perhaps, to the extreme moisture of their environment.

An apparatus for the bacteriological sampling of well water was described and illustrated by Professor H. L. Bolley, the merits of which were facilities afforded for sterilization in toto, and in general accuracy of work afforded without contamination by air and water.

Mr. C. L. Pollard described the methods of work in the National Herbarium. The colored labels in use to designate type specimens were made of special interest, because of the new range offered for convenience of reference.

Passing to order of unfinished business, Dr. Trelease called for the report of the committee appointed at the Rochester meeting to prepare and print a check list of the plants of northeastern North America. Dr. N. L. Britton, as chairman of the committee, submitted the appended report:

"The Committee reports that it has completed the task assigned it by the Club at its Rochester and Madison meetings, by preparing, to the best of its ability, a list of plants in accordance with instructions received at those meetings. The Committee herewith presents a printed copy for such list, which has been prepared and published without expense to the Club.

For the Committee,

N. L. BRITTON,

Chairman."

Mr. O. F. Cook, seconded by Dr. F. H. Knowlton, moved the acceptance of the report. After some discussion as to the scope of the term 'acceptance' as here moved, an adjournment was taken until afternoon without action being taken upon the motion.

FRIDAY AFTERNOON, AUGUST 30.

Following the regular session of Section 'G,' the Club, upon further discussion, adopted the motion of Mr. Cook to accept the report.

On motion of Prof. L. H. Bailey the Club then proceeded to the discussion opened in the morning by passing the regular program.

On motion of Mr. F. V. Coville, seconded by Prof. E. L. Greene, and carried, it was resolved that the meeting proceed to a discussion of the principles on which the list was based.

Dr. B. L. Robinson then alluded to certain generic names which he thought had been inconsistently employed in the list. He also discussed the admission of specific names first published as synonyms. The practice of admitting such names was defended by Prof. Greene, who maintained that the practice of 'taking up of synonyms' as used by the committee was a principle established by Gray.

Prof. N. L. Britton also maintained that the principles adopted by the Club at the Rochester meeting required the admission of such synonyms as those cited by Dr. Robinson.

After much rambling discussion, the following resolution, offered by Professor Britton, and seconded by Professor L. H. Bailey, was adopted:

Resolved, That in view of the opinions which have been expressed at home and abroad on principles of nomenclature, during the progress of the work of the committee, the matter be referred to the committee for consideration and report at the next meeting of the Club.

Prof. Britton also introduced the following resolution:

Resolved, That the committee be increased to eleven members by the additions of Dr. B. L. Robinson and Dr. C. S. Sargent.

At this point Dr. B. L. Robinson stated that, because of the radical difference of opinion existing between himself and the majority of the present committee upon certain vital points, it was plain to him that he must decline to serve upon the committee. In compliance with these wishes, the Club reluctantly accepted Dr. Robinson's withdrawal, and upon motion Professor L. H. Bailey's name was substituted in the resolution, and the same adopted as amended. The Club then adjourned to meet at the same place at 9 A. M., Monday, September 2d.

MONDAY MORNING, SEPTEMBER 2.

Prof. N. L. Britton, Dr. W. H. Seaman and Mr. Walter Deane were appointed a committee to nominate officers for the next meeting. The report of Treasurer F. C. Newcombe, showing the balance in hand, \$6.57, was read and accepted.

The first paper was read by Mrs. Elizabeth G. Britton, entitled 'Some Notes on *Dicranella heteromalla* and allied Species.'

Prof. J. C. Arthur described a new form of clinostat, and remarked on its advantages over similar machines previously constructed, its great superiority being multiple arms for holding plants, allowing of checks upon tests made.

A paper by Mr. A. B. Seymour describing the Mary A. Gilbreth collection illustrating the dissemination of seeds, now the property of Radcliffe College, was read by Mrs. Flora W. Patterson.

Judge David F. Day described the dissemination of the seeds of *Zinnia* by means of the persistent ray-flowers.

Mr. Walter Deane mentioned the expulsion of the seed from the capsules of the Witch-hazel, *Hamamelis Virginica*, stating that he had observed them strike a pane of glass fourteen feet away with almost force enough to crack it.

Judge Day spoke also on the desirability of further observations on climbing plants, referring to his observations on the genus *Dioscorea*, some species of which twine in one direction, others in another. He mentioned *Aconitum uncinatum* as a twining plant, and had observed a secondary peduncle in *Anemone Virginiana* twining around the primary one.

The following papers were read by title during the meetings:

'Notes upon Pig-nut Hickories,' by William Trelease.

'Experiments with Lime as a preventive of Club-root,' by B. D. Halsted.

'Notes on the alkaline Reaction of the

vascular Juices of Plants,' by Erwin F. Smith.

'Continuation of Experiments upon the Relation between the fertile and sterile Lervæ of *Onoclea*,' by George F. Atkinson.

'A Hybrid between an Egg Plant and Tomato Plant,' by P. H. Rolfs.

'A Method of using Formalin Gelatine as a Mounting Medium,' by A. F. Woods.

The committee appointed to nominate officers submitted the following names and they were unanimously elected:

President, Frederick V. Coville, Washington, D. C.

Vice-President, Conway McMillan, Minneapolis, Minn.

Secretary and Treasurer, J. F. Cowell, Buffalo, N. Y.

The Secretary was requested to append to the minutes for future reference a list of persons who have been officers of the Club since its formation.

The Club then adjourned to meet as usual during the meeting of the Association in 1896.

Fifty-three botanists were registered during the different sessions.

H. L. BOLLEY,
Secretary pro tem.

THE BOTANICAL SOCIETY OF AMERICA.

THE first annual meeting of the Botanical Society of America was held in Springfield, Mass., August 27 and 28, 1895. The Council, having all members present, met in the afternoon of the 27th. The consideration of names proposed for membership, the canvassing of ballots cast for officers and transaction of other business engrossed the attention of the Council for an hour and a half.

The Society was then called to order by the President, Wm. Trelease, of St. Louis. The first day's session and a portion of those of the second day were devoted to business.

Four new members were elected: Mr. M.

S. Bebb, of Rockford, Ill.; Prof. W. R. Dudley, of Leland Stanford University; Prof. D. P. Penhallow, of McGill University, and Dr. W. A. Setchell, of Yale University.

The following officers were elected for 1896: President, Prof. C. E. Bessey, of the University of Nebraska; Vice-President, Prof. W. P. Wilson, of the University of Pennsylvania; Treasurer, Prof. Arthur Hollick, of Columbia College; Secretary, Prof. Charles R. Barnes, of the University of Wisconsin. Councillors, Dr. B. L. Robinson, of Harvard University, and Prof. G. F. Atkinson, of Cornell University.

Dr. A. W. Chapman, of Apalachicola, Fla., was elected unanimously an honorary member of the Society. Dr. Chapman, the well-known author of a 'Flora of the Southern United States,' is the first honorary member to be elected. His advanced age, precluding active membership, and his pioneer services in making known the vegetation of the Southern States, were felt to be sufficient warrant for this action.

Contributions of books having already been received by the Society, it was ordered that such be deposited in the library of the Missouri Botanical Garden, subject to the order of the Council, and the Secretary be directed to report to the Society the annual additions.

The Treasurer's report showed a cash balance of \$354.

The following resolution was presented by Prof. L. H. Bailey at a session subsequent to the reading of Dr. Britton's paper on 'The New York Botanical Garden,' and was unanimously adopted:

Resolved, That the Botanical Society of America express its thanks to Dr. N. L. Britton for his account of the condition and progress of the movement for a botanical garden in the city of New York, and congratulate the people of that city on the prospect of its rapid development; and, furthermore, that the Society commend the

Board of Managers of the garden and its Board of Scientific Directors for their wisdom in securing a broad foundation and an assurance of liberal management.

The following papers were read before the Society :

Some notes on a revision of the genus *Mnium*, illustrated with specimens and photographs of types : ELIZABETH G. BRITTON.

The New York Botanical Garden : N. L. BRITTON.

A contribution to a knowledge of North American phycophilous fungi : GEO F. ATKINSON.

The genus *Liriodendropsis* : ARTHUR HOLICK.

The Laboulbeniaceæ : ROLAND THAXTER.

Notes on aquatic fungi : ROLAND THAXTER.

A synopsis of North American rushes : FREDERICK V. COVILLE.

Summary of a revision of the genus *Dicranum* : CHARLES R. BARNES and RODNEY H. TRUE.

Corrections in the description of *Coscinodon Ravei* and *O. Renauldi*, and a comparison of these species : ELIZABETH G. BRITTON
CHARLES R. BARNES.

UNIVERSITY OF WISCONSIN.

SCIENTIFIC NOTES AND NEWS.

A NEW JURASSIC PLESIOSAUR FROM WYOMING.

THE writer has recently been fortunate in finding in the Baptonodon Beds of the Upper Jurassic of Wyoming the remains of a large Plesiosaur, the first of the group from the Jurassic found in America. The horizon is below that of the large Dinosaurs. The precise generic location of the specimen is at present difficult, until more of the specimen has been detached from the hard matrix. It is, therefore, placed provisionally in the genus *Cinoliosaurus*, to which the ascertained characters seem to refer it. The species may be known as *C. rez.*

A centrum of a dorsal vertebra measures

108 mm. in length by 130 mm. in transverse diameter. An anterior cervical centrum is deeply cupped on one end and nearly flat on the other, and measures 65 mm. in length by 80 mm. in width. The arch is united by suture, and the ribs have a single attachment. The femur is about 1200 mm. in length (a portion of the shaft is missing), 375 mm. in width at the distal end, and 300 mm. at the head. A basal phalange is 105 mm. in length, 65 mm. in width at either end and 37 mm. through the shaft.

A full description of the remains found will be shortly given by Professor Williston and the writer. W. C. KNIGHT.

THE EARLIEST NAME FOR STELLER'S SEA COW AND DUGONG.

IN 1811, Illiger published a number of new genera,* proposing among others, *Rytina* for the sea cow of Bering Island and *Halioore* for the dugong of the Indian Ocean. Nearly all recent writers on mammals have adopted these genera, apparently overlooking the fact that both animals had been named before 1811: As early as 1794 Retzius described the sea cow in the 'Handlingar' of the Stockholm Academy of Science, placing it in a new genus which he called *Hydrodamalis*,† and the species, based on the *Vacca marina* of Steller, *Hydrodamalis stelleri*. The generic description is sufficient to identify the animal even if the species and the vernacular name used by Steller had not been given. As *Hydrodamalis* has 17 years priority over *Rytina* it should be adopted as the generic name of the northern sea cow. The earliest specific name is that given by Zimmermann in 1780, and the species should stand *Hydrodamalis gigas* (Zimm.). The abandonment of *Rytina* necessitates a change in the name of the family (*Rylinidæ*), which

* Prodomus Syst. Mamm. et Avium.

† Kongl. Vetensk. Acad. nya Handlingar, Stockholm, XV., Oct.-Dec., 1794, p. 292.

may be called *Hydrodamalide*, there being no other genus in the group.

Lacépède, in 1801, used *Dugong** as a generic name for the sirenian afterwards called *Halicore* by Illiger, but not being a classical word it did not come into general use. As it is the first name for the genus there seems to be no good reason for not adopting it. The specific name was first proposed by Müller in 1776,† who spelled it *dugon*—without the final g. This was evidently not a misprint, as the same spelling occurs twice. The name for the dugong will, therefore, be *Dugong dugon* (Müller), while the unfortunate compound *Dugongida* becomes necessary for the family, instead of the more euphonious *Halicoridae*.

T. S. PALMER.

WASHINGTON, D. C.

AN INTERNATIONAL ZOÖLOGISTS' DIRECTORY.

MESSRS. FRIEDLÄNDER & SON, of Berlin, have just issued a very useful 'International Zoölogists' Directory' of 740 pp. octavo, containing about 12,000 names and addresses. It includes to a certain degree the official position of each person, for it is not a simple alphabetical list, but has several subdivisions, the classification being primarily geographical by countries. Under the country the towns are given alphabetically, excepting that the capital is placed first. Under each place are given, first, names of those attached to the different educational and scientific institutions (each institution apart), and here the names are given in the order and with the specification of their rank; unattached names follow alphabetically; some names, therefore, appear more than once, but only once in full. There is much supplementary information in brief statements regarding the publications of the different institutions. The specialties of each person are given in

an abbreviated form, and the names are again classified in a scientific register (37 pp.) at the end under each specialty, and here names of those not authors and merely collectors are designated by an asterisk. Dealers and natural history artists are given last and separately under each place. Separate geographical and personal indexes enable us quickly to find what we may seek in the volume. It is excellently planned and admirably executed. We hope it has come to stay, but it will need constant revision.

NATURAL SCIENCE TRAINING FOR ENGINEERS.

IN an article in the *Engineering Magazine* for September, Professor N. S. Shaler considers the question "as to the share of natural science which should be incorporated in the several four-year courses leading to the bachelor's degree in the departments of civil, electrical, mechanical and mining engineering." The reorganization of the Lawrence Scientific School of Harvard University has made the investigation of this question desirable, and the results of the inquiry have to a great extent been embodied in its schemes of instruction. Sound general instruction in physics, knowledge of the principles of chemistry, an elementary course in geology, a good theoretical training in metallurgy, a certain amount of determinative mineralogy and an elementary half course in geography are enumerated as necessities for every engineer. The time required for the study of these subjects is about four-fifths of the study period of a college year, which is evidently excessive. Prof. Shaler considers that the burden of the student may be considerably lightened by attendance at the summer school of the University, when each student is required to give his time to one course. "It has been found that the six weeks' term, owing to the concentration of attention, serves to carry the pupil

* Mém. de l'Institut, Paris, III, 1801, Nouv. Tabl. Méthod., p. 501.

† Natursystems Suppl., 1776, pp. 21-22.

quite as far as he is likely to advance in an ordinary year of work. * * * Including the year of his entrance, a student has four summers at his disposal before attaining his bachelor's degree. By giving up six weeks of each of three vacations he may win all the time required for the elementary science courses which are to be expected of the engineer." The latter part of the paper is devoted to the requirements of engineers who wish to be fitted for any one of the several branches of the profession, and considers in turn mechanical, electrical, marine; hydraulic, topographical and mining engineering, for each of which it is necessary that work in particular sciences should be carried to a higher plane. Professor Shaler considers it "an open question as to whether our science schools are not going too far in the effort to acquaint their students with the details of the several departments of engineering. * * * It is likely that in the end our schools will confess a limitation in their work and win firm ground by acknowledging that their province is to give the student a thorough education in the original sense of the word, supplying him with a large theoretical outfit, leaving the technique of his occupation to the time he begins work in a particular employment." Another argument for this point of view is that the education of an engineer differs from that of candidates for other professions. The classics and much else studied with the sole object of culture are perforce omitted. Professor Shaler says: "While I fully believe that natural science can do an excellent part in the civilizing process, it cannot do this if the teaching be devoted to immediate ends. The work must be done in the large, truly academic way; it must take the subject for itself, and not as a mere means to a professional result." The article concludes with a plea for the addition of one year to the curriculum of the technical schools: "While

the way to a profession through the path of the college may be held to be too long, that through the technical school is clearly too short for the needs of the work their graduates have to do." The extra year, besides making it much easier to add a fitting amount of natural science to the curriculum of the engineer, would also be a decided gain in the opportunities for studying English, French and German, and would admit of a more advantageous distribution of professional studies than can be accomplished under the present system.

GENERAL.

PROFESSOR C. L. DOOLITTLE writes that the University of Pennsylvania has begun the erection of an Astronomical Observatory; the purpose being to furnish facilities for instruction in astronomy and for original research. The site is five miles west of the present University buildings, being two miles beyond the city limits. The principal instruments are an 18-inch Equatorial, with Spectroscope, a Meridian Circle and a Zenith Telescope, each of 4 inches aperture. The optical parts are by Brashear, the instrumental by Warner & Swasey. As the Observatory Library is for the most part a thing of the future, any publications relating to astronomy or allied subjects which may be sent will be very acceptable. At present the Observatory has nothing to offer in exchange, but hopes to have at a future time. Contributions may be sent to The Flower Observatory, University of Pennsylvania, Philadelphia.

MR. O. H. TITTMANN, assistant in the Coast and Geodetic Survey, has been appointed delegate from the United States to the International Geodetic Association that meets in Berlin on the 30th inst., and sailed from New York on the 17th.

PROFESSOR ERNST RITTER, whose appointment as assistant professor of mathematics

in Cornell University, was recently announced, died on September 23d, of typhoid fever, on his arrival from Germany. The *New York Tribune* gives the following particulars concerning his life: Ernst Ritter was born at Waltershausen, Germany, on January 9th, 1867. He spent twelve years at the gymnasium at Gotha, and afterwards studied mathematics and natural science under Thomas, at Jena, and under Klein and Schwartz, at Göttingen. In 1890 he passed the government teacher's examination with the highest distinction, after two years of pedagogical work at Cassel, and at the Wöhlerschule in Frankfurt. He took the degree of Ph. D., *summa cum laude*, at Göttingen in 1892. In 1893 he was appointed assistant to Professor Klein, and began to devote his entire time to mathematics, contributing regularly to mathematical periodicals. Last year he lectured on geometry and the theory of automorphic functions, in which he was an authority. He was appointed to his Cornell professorship last June.

THE death is announced of Samuel C. Booth, mineralogist and naturalist. Mr. Booth began life as a poor farmer, but at the age of fifty years had gained a competency. He spent, however, much time in scientific study and became recognized as an authority in his chosen branches, and was able to leave behind much valuable information on scientific subjects, and a collection of rare minerals.

THE Institute of France has appointed a large and influential committee to further the object of erecting a statue of Lavoisier at Paris. It has been decided to make the memorial international and the committee have issued a circular asking help from all who wish to do honor to the memory of the great chemist.

THE Danish Academy of Sciences offers five prizes for papers which must be pre-

sent before the end of October, 1896, to Secretary of the Academy, Prof. G. H. Zeuthen, Copenhagen. The subjects are as follows: (1) The Electrolysis of Organic Substances; the gold medal of the Academy valued at 320 kr. (2) Algebraic Equations with their Numerical Coefficients in Relation to the Abel Equations; the gold medal of the Academy. (3) Field Mice and their Food; prize of 400 kr. (4) The Physical Constitution of Cultivated Earth; prize of 600 kr. (5) The bacteriological products in sour milk; prize of 400 kr.

LA SOCIÉTÉ de Médecine Publique et d'Hygiène Professionnelle, according to an announcement in the *British Medical Journal*, offers a prize for an essay on the following subject: 'Preventable Diseases; Means of Preserving Oneself from them and Preventing their Diffusion.' The prize is open to competitors of all nationalities. The essays, which must be written in French, must be sent in—with the usual precautions as to anonymity—before October 10th, to M. Cheysson, 115 Boulevard St. Germain, Paris. The first prize is of the value of £48, the second of £32. The sum of £20 will be distributed among 'honorable mentions.'

PROFESSOR HALLOCK writes that, in the list of colors given in the abstract of J. H. Pillsbury's paper on page 353, green should be inserted, making the colors: red, orange, yellow, green, blue and violet, with black and white.

THE Third South African Medical Congress was held at Durban from July 12th to 19th.

It is reported that news has been received from a Danish trading station that a three-masted ship corresponding to Dr. Nansen's vessel, the 'Fram,' was seen by Eskimos last July embedded in an ice drift, and somewhat to the southward of 66° N. latitude.

UNIVERSITY AND EDUCATIONAL NEWS.

PROFESSOR W. A. SETCHELL, of Yale University, has accepted a call to the chair of botany in the University of California, vacant through the removal of Professor E. L. Greene to the Catholic University of Washington.

A SUIT has been brought by Yale University against Storrs College to determine the disposition of the Government appropriation (about \$20,000 a year) to agricultural colleges. This money was paid to Yale University from the time the fund was appropriated, in 1862, till it was diverted to the fund of Storrs College, in 1893. Since this date the money has been tied up by reason of the suit of Yale University to restrain the Treasurer from paying the money to Storrs College.

PROFESSOR HENRY TALBOT has been appointed associate professor of chemistry in the Massachusetts Institute of Technology.

THE following changes have been made in the medical faculty at Yale University: Dr. Cheney and Dr. Henry L. Swain have been appointed to professorships; Dr. Oliver T. Osborn and Dr. Louis S. DeForest have been made assistant professors, and Mr. C. J. Bartlett instructor in bacteriology.

QUEEN'S COLLEGE, Belfast, Ireland, attains its jubilee this year. It has been, however, resolved to postpone the celebrations till next year, when it is hoped that many alumni from different parts of the world will find it possible to be present.

THE number of Freshmen admitted to Harvard University by examination is 465, as compared with 418 last year. The scientific school shows a gain of 22 students; 104 were admitted this year as compared with 84 last year.

THE Freshman Class at Williams College; the largest in its history, numbers about 124 members. The Freshman Class

at Boston University, also the largest yet assembled, shows an increase of 50 over last year.

CORRESPONDENCE.

PROFESSOR HALSTED REPLIED TO.

EDITOR OF SCIENCE: Your number of September 6th appeared while I was in Europe, so that I am late in replying to an extraordinary charge made against me on page 309 by Professor Halsted, as follows:

"This letter of Beez incited Dr. McClintock to an examination of Beltrami's article and a paper on it under the title 'On the early history of the non-Euclidean geometry,' where, among other mistakes, he makes one peculiarly entertaining. He says, p. 145, Bulletin, Vol. II., of Saccheri: 'He confessed to a distracting heretical tendency on his part in favor of the hypothesis anguli acuti, a tendency against which, however, he kept up a perpetual struggle (diuturnum proelium). After yielding so far as to work out an accurate theory anticipating Lobatschewsky's doctrine of the parallel-angle, he appears to have conquered the internal enemy abruptly, since, to the surprise of his commentator, Beltrami, he proceeded to announce dogmatically that the specious hypothesis anguli acuti is positively false.' Who would suspect that all that is a pure fairy tale evolved by Dr. McClintock from his mistranslation of a passage immediately announced by the two Latin words he fortunately retained in parenthesis?"

This is all that Professor Halsted now says of my paper which he names and from which he quotes. He does not mention that half of that paper consists of a brief but careful resumé of the claims of Gauss, to which he devotes so large a part of the review to which I am replying, nor does he recollect that at the time when my paper appeared he wrote me (April 17, 1893), "I was delighted with your article on the Early History of the Non-Euclidean Geometry," giving no hint of dissatisfaction, but going on among other things to refer to an earlier paper of mine as 'your epoch-making article on the Non-Euclidean Geometry.' He sent me a second letter on April 27, 1893, again of the friendliest and most appreciative sort, but not referring to the paper in question; showing that the half on Saccheri as well as the half on Gauss met at that time with no disapproval on his part.

Professor Halsted has since added to our obligations to him as the bibliographer of this subject by obtaining the original Latin treatise of Saccheri and translating it into English. He found from the beginning that the two words quoted by Beltrami and from Beltrami by me, *diuturnum prælium*, were meant by Saccheri to indicate a mental attitude of constant war against the 'hypothesis' as heretical, without any such 'struggle' in his own mind as he appeared, from my reading of Beltrami, to have 'confessed.' The words of Beltrami are not inconsistent with my rendering of the two Latin words.

In May, 1894, on Professor Halsted challenging my word 'confessed,' etc., and sending me his Latin copy of Saccheri, I denied my mistranslation of what Beltrami had set before me, though acknowledging that I had, through the ambiguity of my material, credited Saccheri with a confession of what he did not confess (though he doubtless felt it, as intimated by Beltrami), the 'distracting heretical tendency.' In the last letter which I find on this subject from Professor Halsted, May 8, 1894, he says properly: "In my interpretation of the facts as they exist in the book I am inclined to go much further than Beltrami or yourself. But I wish to distinctly separate historic fact from interpretation, however probable or however much called for." There was no hint that I should publish any correction. I assumed that he would make the case clear in bringing out his translation of Saccheri.

The reader will now observe that I am charged with 'other mistakes,' of which no specification is or has ever been given, publicly or privately, and will form his own judgment. He will kindly note that I am charged with 'mistranslation,' after I had quoted to Professor Halsted the Italian and Latin context of the two Latin words in question and received no reply expressing dissatisfaction, and will form his own judgment. He will finally remark that my references to Beltrami's surprise, etc., are ridiculed as a 'pure fairy tale,' contrary to the fact, by this usually staunch upholder of historical accuracy, and will form his own judgment. And after all he will probably form a wholly incorrect judgment of Professor Hal-

sted's motives, however correct it may be of his imprudence; for I have had too many proofs of personal friendliness from him not to feel sure, in spite of this injury he has done me, that he had no idea that his hasty phrases could injure me, and no motive other than that of 'pointing a moral' for the moment.

EMORY MCCLINTOCK.

MORRISTOWN, Sept. 24, 1895.

SCIENTIFIC LITERATURE.

The Climates and Baths of Great Britain. Vol. I. London and New York, Macmillan & Co. 1895. 8vo. pp. xvi+640.

This volume contains the first part of the report of a Committee of the Royal Medical and Chirurgical Society of London, which Committee was appointed in 1889 to investigate certain questions relating to the climatology and balneology of Great Britain and Ireland, and includes the results of correspondence with medical men, of personal investigations by members of the committee and of the analysis of meteorological and medical statistics relating to the various localities. This first volume relates to the climates of the South of England and the chief medicinal springs of Great Britain.

The chairman of the Committee is Dr. W. M. Ord, of London, and his name is a sufficient guarantee of the accuracy and scientific impartiality of the statements made. In his introductory remarks he points out the contrast between England and Continental Europe from the point of view of the seeker of health, the former furnishing chiefly seacoast resorts while the main sanatory resources of the continent are inland and mountainous.

While a large part of this report is mainly of local interest, being intended especially as a guide to English physicians in prescribing certain health resorts to certain classes of patients, the general principles upon which its recommendations are based are as applicable to many American resorts as they are to the English ones. For example, much of what is said as to the class of cases which may hope for benefit or as to the other class of cases which are likely to be injured by the hot waters of Bath is equally applicable to the Hot Springs of Virginia or of Arkansas. So far as seaside resorts

are concerned, England is peculiarly fortunate in having such a number and variety of them on the southern coast, which presents great differences in outline, soil and climatic influences of various kinds. Dr. Ord remarks that "where a ridge comes down from high inland into the sea, its shelving sides are found to embrace great differences of climate within a small area. We may find one side of a bay exposed to east winds, with an air which is found to be tonic and bracing, while, on the other side, with a westerly or southwesterly aspect, the sun pours in on a beach lying at the foot of high cliffs with almost tropical warmth; and one side of a headland may be so warm as to be held to be relaxing, while the other is cool and invigorating."

In the section on the Climate of Devonshire attention is called to the fact that for years this region has been considered as specially favorable for those suffering from all forms of respiratory trouble, and the reporters, Dr. Symes Thompson and Dr. Lazarus-Barlow, say "from this cause it comes about that a large proportion of the permanent residents have become such from either some actual or hereditary tendency to diseases of the respiratory type." To this it might be added that so far as consumption is concerned, any locality to which large numbers of persons affected with pulmonary tuberculosis have resorted for a number of years is specially liable to be infected with the specific bacillus from dried sputa, wherever this has been deposited in more or less dark places.

In speaking of one locality the significant remark is made that "typhoid fever has virtually disappeared from Sandown since the new water supply was established in 1863."

The really valuable thermal and mineral springs of Great Britain are comparatively few in number. There are no alkaline waters. Bath and Buxton are the only thermal waters of importance. Harrogate and Strathpeffer are the chief sulphurous spas, and the strongest saline waters are those of Droitwich and Nantwich. There are no chalybeate springs of great reputation, but there are several which have considerable value.

Considering the great number and variety of

thermal and mineral waters in the United States, many of the springs containing considerable quantities of salts, having important therapeutic qualities, it is much to be desired that a scientific, impartial report upon them, similar to the one above referred to, should be prepared and published for the benefit not only of our own people, but of the world at large. No doubt at present it would be impossible to obtain the requisite data, for while we have a fair amount of reliable chemical analyses of the different waters, the statistics of disease and death are for the most part wanting and the meteorological data are still incomplete, although much has been done in this direction within the last ten years.

In the meantime, until we can have such a report of our own, those who are interested in health resorts, whether as physicians, patients, or friends of the sick, will find much in this volume to interest and instruct them.

J. S. BILLINGS.

Leitfaden für histologische Untersuchungen. VON DR. BERNHARD RAWITZ, Privatdozenten an der Universität Berlin. Zweite umgearbeitete und vermehrte Auflage. Pp. 148, no figures. Verlag von Gustav Fischer, Jena, 1895.

The purpose of this work, as the title states, is to furnish a guide to histological investigation. It is divided into two main sections. The first is devoted to the methods of histology, fixing, hardening, sectioning, staining, etc., and the principles involved in these proceedings. The second part takes up all of the tissues and organs and shows how the methods are applied. Cross references are constantly given, so that only a minimum of repetition is necessary.

The author's preparation for the task has been excellent. Besides the training of the German laboratories, he has prepared an excellent manual of histology and has written several papers giving the results of his own histological investigations.

In going carefully over the methods one can see the discrimination that has been exercised by the author in selecting, from the great number of possible methods, those that his own experience and that of others have found most reliable and most capable of giving the best gen-

eral results. The book seems to be a thoroughly trustworthy guide to modern histology. The author emphasizes the need of keeping physiology constantly in mind in studying morphology; this is one of the crying needs of morphological study at the present time, and it may be safely predicted that future advances will most often be made by those who see in morphology the agent or material vehicle of physiology.

Unlike most guides to investigation in which a microscope is necessary, this one omits all consideration of the instrument of the investigator. The author believes that as the microscope is a physical instrument it should be studied in a course on physics. He stands nearly or quite alone in this respect. Most teachers have found that the special application of an instrument could best be taught in actually applying the instrument to the investigation, and the best instructor is the one who has had experience in the use of the special instrument, it being always understood, of course, that the teacher has an adequate knowledge of the theory of the instrument. The author also believes that in a work on histology the methods by which the results are obtained should find no place, but be in a separate volume. He is here also largely in a minority, as the best works on modern histology give the methods by which each preparation has been obtained. This is sometimes given with the preparation or at the end of the chapter. The advantage is that a student can follow exactly the method of the book he is studying and avoid the confusion of being compelled to make his own selection from several methods. The uncertainty as to the cause of any failure is thus largely eliminated.

From the standpoint of a teacher who has had much experience with students, the reviewer is compelled to say that it would require one of experience to make the best use of this guide, as in many, if not the majority of, cases the directions are so brief that a beginner would find it impossible to fill the gaps. For one with experience, however, the book would serve an excellent purpose, for its directions include many late methods, and the general discussions are very suggestive. A drawback for the teacher is the lack of references to the sources of the

various methods given. Credit is given, as Ranvier's method, etc., but no reference to the place in which the full discussion can be found, and certainly in a book serving as a guide to investigation—and this professes to be such—the investigator should be given every aid. The *Microtomists' Vade Mecum* of Lee is far more satisfactory in this respect.

In a word, the book, with all its excellencies, is too brief for beginners without experienced teachers, and for the advanced worker the lack of references to original sources detracts greatly from its usefulness. S. H. G.

SCIENTIFIC JOURNALS.

PSYCHE, OCTOBER.

THE number is almost exclusively given to a revision of the species of the orthopteran genus *Spharagemon* by A. P. Morse. The author divides it into three series: *bolli* (with 4 species), *æquale* (3) and *collare* (2); but he further divides *S. collare* into no less than six races, to which he gives names; considerable change in the synonymy results. Excellent outline figures are given of the face of six of the commoner species with a few other characteristic parts. Three new species are briefly described. The genus is strictly North American and has not been found west of the Sierra Nevada. Mr. Morse expresses no definite opinion regarding the intimacy of its relationship to *Dissosteira*, under which Saussure placed it as a subgenus.

NEW BOOKS.

Report of the Chief of the Weather Bureau for 1893. Washington. Government Printing Office. 1894. Pp. 319.

The Forces of Nature. HERBERT B. HARROLD and LOUIS A. WALLIS. Columbus, Ohio, the authors. 1895. Pp. 159.

Psychology in Education. Ruric N. Roark. New York, American Book Company. 1895. Pp. 312. \$1.00.

The Herschels and Modern Astronomy. AGNES M. CLERKE. New York, Macmillan & Co. 1895. Pp. vi+224. \$1.25.

Justus von Liebig, His Life and Work (1803-1873). W. A. SHENSTONE. New York, Macmillan & Co. 1895. Pp. vi+215. \$1.25.

SCIENCE

NEW SERIES.
VOL. II. No. 41.

FRIDAY, OCTOBER 11, 1895.

SINGLE COPIES, 15 CTS.
ANNUAL SUBSCRIPTION, \$5.00.

GUSTAV E. STECHERT'S

Recent Importation of Scientific Books.

BECKERT, TH. and DR. ALBANO BRAND. Hüttenkunde. Mit 235 in den Text gedruckten Figuren. 765 Seiten. gr. 8°. Mk. 20.

BREHENS, H. Anleitung zur mikrochemischen Analyse. Mit einem Vorwort von Prof. S. Hoogewerf in Delft. 224 Seiten mit 92 Figuren in Text. 8°. Mk. 6.

BIEDEMANN, W. Elektrophysiologie. 1^{te} Abtheilung. Mit 136 Abbildungen. 440 Seiten. 8°. Mk. 9.

BORCHERS, DR. W. Elektro-Metallurgie. Die Gewinnung der Metalle unter Vermittlung des elektrischen Stromes. 2^{te} verm. v. völlig umgearb. Auflage. 1^{te} Abtheilung, mit 87 Abbildungen. 160 Seiten. gr. 8°. Mk. 6⁰⁰.

BUSCHAN, GEORG. Vorgeschichtliche Botanik der Cultur-u. Nutzpflanzen der alten Welt auf Grund prähistorischer Funde. 268 Seiten. 8°. Mk. 7⁰⁰.

DAMMER, DR. O. Handbuch der chemischen Technologie. Unter Mitwirkung von Direktor Th. Beckert, Dr. Bender, Dr. Benedikt, Dr. Börnstein u. A. herausgegeben. 2^{ter} Band. Mit 235 in den Text gedruckten Figuren. gr. 8°. Mk. 20.

DELAGE, YVES. La structure du protoplasma et les théories sur l'hérédité et les grands problèmes de la biologie générale. 878 pages. gr. 8° cloth. frs 24⁰⁰.

DETMER, DR. W. Das pflanzenphysiologische Praktikum. Anleitung zu pflanzenphysiolog. Untersuchungen für Studierende u. Lehrer der Naturwissenschaften, sowie der Medicin, etc. 2^{te} völlig neu bearbeitete Aufl. Mit 184 Abbildungen. 456 Seiten. 8°. Mk. 9.

FOREL, DR. AUGUST. Der Hypnotismus, seine psycho-psysiologische medicinische, strafrechtliche Bedeutung und seine Handhabung. 3^{te} verb. Aufl. mit Annotationen von Dr. O. Vogt. 223 Seiten. gr. 8°. Mk. 5.

FRANK, DR. A. B. Die Krankheiten der Pflanzen. Ein Handbuch für Land u. Forstwirte, Botaniker, etc. Erster Band, Die durch anorgan. Einflüsse hervorgerufenen Krankheiten. Mit 34 Holzschnitten. 2^{te} Aufl. 344 Seiten. 8°. Mk. 6⁰⁰.

HIS, WILH. Die anatomische Nomenclatur. Nomina anatomica, Verzeichniss der von der anatomischen Gesellschaft auf ihrer 9. Versammlung in Basel angenommenen Namen. Mit 30 Abbildgn. im Text und 2 Tafeln. 180 Seiten. Mk. 7⁰⁰.

HOUDAILLE, F. Météorologie agricole. 204 pages cloth. fr. 3.

JAHRBUCH DER ELEKTROCHEMIE. Berichte über die Fortschritte des Jahres 1894. Im wissenschaftlichen Theile bearbeitet von Dr. W. Nernst. Im technischen Theile bearbeitet von Dr. W. Borchers. 1^r Jahrgang. 274 Seiten. gr. 8°. Mk. 10.

JERUSALEM, WILH. Die Urtheilsfunction. Eine psychologische und erkenntniskritische Untersuchung. 269 Seiten. Mk. 6⁰⁰.

LOEWY, DR. A. Untersuchungen über die Respiration and Circulation bei Aenderung des Druckes und des Sauerstoffgehaltes der Luft. Mit 5 Curventafeln im Text. 155 Seiten. gr. 8°. Mk. 4.

MEYER, DR. ARTH. Untersuchungen über die Stärkekörner der höheren Pflanzen. Mit 9 Tafeln u. 99 Text-Abbildgn. 318 Seiten. gr. 8°. Mk. 20⁰⁰.

NIEDENZU, DR. FRANZ. Handbuch für botanische Bestimmungsübungen. Mit 15 Figuren im Text. 351 Seiten. 8°. Mk. 4.

SCHAFFER, DR. KARL. Suggestion und Reflex. Eine Kritisch-experimentelle Studie über die Reflexphänomene des Hypnotismus. Mit 6 Tafeln in Lichtdruck und 11 Abbildungen im Text. 113 Seiten. gr. 8°. Mk. 6⁵⁰.

SCHMIDT, DR. ALEX. Weitere Beiträge zur Blutlehre. Nach des Verfassers Tode herausgegeben. 247 Seiten. 8°. Mk. 7.

SCHWARTZE, TH. Die Lehre von der Electricität und deren praktische Verwendung. Mit 153 in den Text gedruckten Abbildungen. 543 Seiten. 8°. Mk. 10⁰⁰.

STEINHARDT, DR. EUGEN. Kurzes Lehrbuch der Chemie zum Gebrauch an Schulen und zur Selbstbelehrung. Zwei Theile. Erst. Teil; Anorganische Chemie. 418 Seiten. 8°. Mk. 6⁰⁰.

VAN BIERVLIET, J. J. Elements de psychologie humaine. Cours professé à l'université de Gand. Avec 34 figures dans le Text. 317 pages. frs. 8.

ZEITSCHRIFT FÜR ANGEWANDTE MIKROSKOPIE herausgegeben von G. Marpmann. Monthly. 1^{er} Band 1^{er} Heft. Per year, \$2.75.

ZEITSCHRIFT, Geographische, Herausgegeben von Dr. Alfred Hettner. 1^{er} Jahrg. 1^{er} Heft. Per year (12 N^{os}) \$4⁰⁰.

ZIMMERMANN, DR. A. Das Mikroskop. Ein Leitfa den der wissenschaftlichen Mikroskopie. Mit 231 Figuren im Text. 334 Seiten. gr. 8°. Mk. 9.

ZITTEL, KARL A. VON. Grundzüge der Palaeontologie (Palaeozoologie). Mit 2048 in den Text gedruckten Abbildungen. 971 Seiten. gr. 8°. $\frac{1}{2}$ mor. Mk. 25⁰⁰.

GUSTAV E. STECHERT,

810 Broadway, New York.

Macmillan & Co.'s New Publications

Mayo-Smith—Statistics and Sociology. Science of Statistics, Part I.

By RICHMOND MAYO-SMITH, Ph. D., Professor of Political Economy and Social Science in Columbia College. 8vo, cloth, \$3.00 *net*. (New volume of the *Columbia University Press*.)

Watson—Hedonistic Theories, from Aristippus to Spencer.

By JOHN WATSON, Professor of Moral Philosophy in the University of Queen's College, Kingston, Canada. 12mo, cloth, \$1.75 *net*.

Loney—The Elements of Co-ordinate Geometry.

By S. L. LONEY, M. A., late Fellow of Sidney Sussex College, Cambridge. Pp. x.+416, 16mo, cloth, \$1.25 *net*.

Eccles—The Practice of Massage: Its Physiological Effects and Therapeutic Uses.

By A. SYMONS ECCLES, M. B. Aberd., Member Royal College Surgeons, England; Fellow Royal Medical and Chirurgical Society, London; Member Neurological Society, London, etc. 8vo, cloth, pp. xii.+377, \$2.50 *net*.

Lassar-Cohn—A Laboratory Manual of Organic Chemistry: A Compendium of Laboratory Methods for the Use of Chemists, Physicians and Pharmacists.

By DR. LASSAR-COHN. Translated, with the author's sanction, from the second German edition. ALEXANDER SMITH, B. Sc., Ph. D. Pp. ix.+403, 12mo, cloth, \$2.25 *net*.

Bastable—Public Finance.

By C. F. BASTABLE, M. A., LL.D., Professor of Political Economy in the University of Dublin. Second Edition. Revised and enlarged. 8vo, cloth, \$4.00 *net*.

Stanley—Studies in the Evolutionary Psychology of Feeling.

By HIRAM M. STANLEY, Member of the American Psychological Association. 8vo, cloth, \$2.25 *net*.

Keith—Plea for a Simpler Life.

By GEORGE S. KEITH, M. D., F. R. C., P. E. 12mo, cloth, \$1.00.

The Rural Science Series.

Edited by L. H. BAILEY. *New Volume.*

King—The Soil. Its Nature, Relations and Fundamental Principles of Management. By F. H. KING, Professor of Agricultural Physics in the University of Wisconsin. 16mo, cloth, 75 cents.

The Century Science Series.

Edited by SIR HENRY E. ROSCOE, D. C. L. *New Volume.*

Justus Von Liebig: His Life and Work. (1803-1873.) By W. A. SHENSTONE, F. I. C., Lecturer on Chemistry in Clifton College. With Portrait. 16 mo, cloth, \$1.25.

MACMILLAN & CO., 66 Fifth Avenue, New York.

SCIENCE

EDITORIAL COMMITTEE: S. NEWCOMB, Mathematics; R. S. WOODWARD, Mechanics; E. C. PICKERING, Astronomy; T. C. MENDENHALL, Physics; R. H. THURSTON, Engineering; IRA REMSEN, Chemistry; J. LE CONTE, Geology; W. M. DAVIS, Physiography; O. C. MARSH, Paleontology; W. K. BROOKS, Invertebrate Zoology; C. HART MERRIAM, Vertebrate Zoology; S. H. SCUDDER, Entomology; N. L. BRITTON, Botany; HENRY F. OSBORN, General Biology; H. P. BOWDITCH, Physiology; J. S. BILLINGS, Hygiene; J. MCKEEN CATTELL, Psychology; DANIEL G. BRINTON, J. W. POWELL, Anthropology.

FRIDAY, OCTOBER 11, 1895.

THE ARCTIC EXPEDITION OF 1895, AND
LIEUTENANT PEARY'S WORK.

CONTENTS:

| | |
|--|-----|
| <i>The Arctic Expedition of 1895, and Lieutenant Peary's Work:</i> ROLLIN D. SALISBURY..... | 457 |
| <i>On Oysters and Typhoid:</i> R. W. BOYCE and W. A. HEEDMAN | 460 |
| <i>Address of the President, Sir Douglas Galton, before the British Association for the Advancement of Science (II.)</i> | 462 |
| <i>Some Notes on Darlington (S. C.) 'Bay':</i> L. C. GLEN..... | 472 |
| <i>A New Method of Determining the Motion of the Stars in the Line of Sight:</i> J. E. K. | 475 |
| <i>Section of Zoölogy of the A. A. A. S.:</i> CHARLES W. HARGITT..... | 476 |
| <i>The Indexing of Chemical Literature</i> | 478 |
| <i>Antarctic Exploration</i> | 480 |
| <i>Current Problems in Plant Morphology (II.):—</i> | 481 |
| <i>The Influence of Spray and Rain on the Form of Leaves:</i> CONWAY MACMILLAN. | |
| <i>Scientific Notes and News</i> | 482 |
| <i>University and Educational News</i> | 484 |
| <i>Correspondence:—</i> | 485 |
| <i>The Absorption of Terrestrial Radiation by the Atmosphere:</i> W. M. DAVIS. <i>Shells as Implements:</i> O. T. MASON. <i>The Inverted Image on the Retina:</i> J. MCK. C. | |
| <i>Scientific Literature:—</i> | 487 |
| <i>Muscular Fatigue:</i> CHARLES HENRY. <i>Allen's Mammals from the Black Hills Region:</i> C. H. M. | |
| <i>Scientific Journals:—</i> | 491 |
| <i>Journal of Geology; The American Geologist.</i> | |
| <i>New Books</i> | 492 |

THE North Greenland Expedition of 1895, s. s. Kite, the primary object of which was to bring Lieutenant Peary and his companions back to the United States, left St. Johns, N. F., on the 11th of July. At this time the members of the party were Mr. Emil Diebitsch, Dr. J. E. Walsh, Mr. Theo. Boutilier and the writer. A little later we were joined by Prof. L. L. Dyche, who had preceded us to the coast of Greenland. The chief scientific work undertaken by members of the party was the collection of birds and mammals by Prof. Dyche, and the study of glacial geology by the writer.

After brief stops at Holstenberg, Godhavn, Jakobshavn, Atanikerdluk and Dalrymple Island, Inglefield Gulf, or perhaps more properly Whale Sound, was reached on the morning of the 31st of July. To this point, but little floe-ice had been encountered, even Melville Bay being essentially free from it along the line of our route. In Inglefield Gulf, twenty-five miles or so from Mr. Peary's headquarters, the ice stopped further progress. From the natives who soon boarded the Kite from the settlement of Karnah, it was learned that Mr. Peary had returned from his journey across the inland ice, and that he, together with Messrs. Lee and Henson, was now at the lodge at the head of Bowdoin Bay. After an unsuccessful attempt to reach the

MSS. intended for publication and books, etc., intended for review should be sent to the responsible editor, Prof. J. McKeen Cattell, Garrison on Hudson, N. Y.

Subscriptions and advertisements should be sent to SCIENCE, 41 N. Queen St., Lancaster, Pa., or 41 East 49th St., New York.

head of the bay by crossing the ice on dog sledges, the lodge was reached on the 3d of August, after an overland journey from the head of McCormick Bay.

The main facts concerning the work of the year were soon learned. The provisions which had been cached on the ice cap for the trip of 1894, not being used that year, were relied upon for the journey of the succeeding season. In September of 1894, after the departure of the Falcon, an attempt was made to visit the nearer caches. One of the objects of the visit was to get the provisions out from beneath the season's snow; so as to make them more accessible when the journey of the following spring should be begun. Although the same caches had been visited in the preceding July and the provisions then raised to the surface of the snow, it was found in September that the snowfall of the summer had been so heavy that neither of the two caches nearest the boarder of the ice could be found, the signals having been completely buried. After this discovery, little hope was entertained that search for the caches would be more successful in the following spring. As the caches on the ice contained the pemmican, which was to have been the chief article of food, and the alcohol which was to have served as fuel, Mr. Peary was obliged to face the prospective loss of both. With this unpleasant outlook, the winter was passed.

Instead of giving up the proposed journey across the ice cap, Mr. Peary made such provision for the trip as was possible, and on the 1st of April, accompanied by Lee and Henson, started for Independence Bay. As had been expected, the important caches were not found. In spite of this the crossing of the ice cap was successfully accomplished, the distal edge being reached on the 13th of May. The rest of the month was spent on the land about the bay. From lack of provisions a longer stay was im-

practicable, and the return journey across the ice was begun on the 1st of June and ended on the 25th.

The enterprise and courage with which Mr. Peary conceived and attempted to execute his plans would seem to have entitled him to more consideration at the hands of the powers that be. On two successive years his well matured plans have been thwarted by circumstances over which he had no control, and upon which he could in no way count.

While adverse circumstances have made it impossible for him to carry out, in full, his plans with reference to the north coast of Greenland, he has nevertheless accomplished much during his Arctic residence. He has twice (in 1892 and 1895) crossed the ice cap from Inglefield Gulf to Independence Bay, and has gathered information concerning the inland ice and the ice-free territory beyond, which possesses unique value. Further he has mapped a considerable stretch of the coast of West Greenland, in the vicinity of his headquarters. The full value of this work will first appear when the map is published, but a few general statements concerning it will indicate something of its scope. It covers the coast from Cape Alexander (lat. 78° 10') on the north to Cape York (lat. 75° 55') on the south. Within this latitude the range in longitude is nearly 8°. The coast is very irregular, as may be inferred from the fact that its actual length, including the islands near the mainland, is about 1,000 miles. A comparison of Mr. Peary's MS. map with the earlier charts of the same region reveals the extent and the importance of the changes, which are so great as to make it apparent that the new map is really such, and not merely a corrected copy of the old. The modifications are so extensive that, were it not for the names, the new map, and the last edition of the chart of the same region, issued by

the Hydrographic Office, would hardly be taken to represent the same coast. In some places the general trend of the coast is altered many degrees. Many bays are mapped which have not hitherto found representation, and many indentations of the coast which have heretofore appeared upon the charts, have been changed in position and size. Eleven islands which do not appear on the published charts referred to have been accurately located, and the position, shape and size of those heretofore represented have been corrected. A large number of glaciers, probably as many as 100, have been located with approximate accuracy within the region where but ten were represented on the published chart, and even these were in some cases in false positions, and greatly exaggerated in size. Astrup's map of Melville Bay, already published, should be mentioned in this connection, since it was prepared while its author was a member of Mr. Peary's corps. Geographers will not fail to appreciate the magnitude and the importance of this cartographic work.

In addition to the map, Mr. Peary has kept a series of meteorological records, probably the most accurate and elaborate which have ever been secured in so high a latitude. Besides the more formal records, he has been observant of the behavior of winds about the ice sheet, and in this way has come into possession of facts which are not without significance in connection with the problems of glaciology. He has made careful measurements of the rate of motion of one of the most active glaciers of the region, and has carried them through a sufficiently long period of time to give them especial value. He has brought back two large and choice meteorites from the coast east of Cape York, the study of which will possess much popular as well as scientific interest.

In quite another line, important studies

have been prosecuted to a successful issue. During his three years and a half of Arctic residence—adding the time of the earlier visit to that of the later—Mr. Peary has made a study of the Eskimos of North Greenland. During this time he has personally come into contact with almost every man, woman and child on the west coast north of the Danish possessions. He has lived among them in such a way as to get from them data which no temporary visitor could secure, and which no one, not understanding their language, and not commanding their confidence, could hope to gain. As a result, he is in possession of much fuller knowledge of these people than any one else has ever been. The results of his study, when published, will be an important contribution to ethnology.

Indirectly, the expeditions which Mr. Peary has caused to be made into northern waters have not been without result. Five successive voyages, without accident, have shown that Arctic navigation, under proper management, is not so dangerous as has been supposed. Through those who have accompanied these expeditions, much information has been secured touching the natural history, the geography and the geology of the regions visited. Some of these data have been published, while others have not yet appeared, but they must nevertheless be taken into account in enumerating the results of the several expeditions for which Mr. Peary has been responsible. It will be readily seen that the returns are, in the aggregate, very considerable, and that, although the object which was first in mind when the last expedition was planned has not been fully attained, the results which have been achieved cannot be looked upon as incommensurate with the outlay.

So far as concerns the results accomplished by the members of the party of 1895, it may be said that Professor Dyche

was successful in getting large numbers of birds and mammals at various points along the coast. He was especially fortunate in securing an abundant supply of walrus, both bulls and cows, goodly numbers of reindeer and seals, and a smaller number of narwhals.

The writer saw much of the west coast of Greenland between latitude 64° and $78^{\circ} 45'$, at close enough range to study its geographic features to advantage. Stops were made near the parallels of 67° , 69° , 70° , and at many points between $75^{\circ} 45'$ and $77^{\circ} 45'$. At all these points geographical and geological studies were carried on. The eastern coast of America was also seen for a considerable distance, especially from Ellsmere land south to $71^{\circ} 30'$, and most of the coast of the island of Disco. On the Greenland coast many glaciers between $75^{\circ} 45'$ and $77^{\circ} 45'$ were studied in detail, and some determinations of significance concerning glacier motion made. A considerable body of evidence was gathered touching the former extension of the ice cap of Greenland. Determinations were also made at several points concerning recent changes of level of the land.

ROLLIN D. SALISBURY.

UNIVERSITY OF CHICAGO, October 4, 1895.

ON OYSTERS AND TYPHOID.*

OUR motives in undertaking this investigation have been:—

1. Purely scientific—the elucidation of the life conditions of the oyster, both under normal and abnormal environment.

2. Economic or technological—to trace the causes and effects of diseased conditions, with the view of determining what basis

*An experimental inquiry into the effect upon the oyster of various external conditions including pathogenic organisms. A paper presented before Section D. at the Ipswich Meeting of the British Association, by R. W. Boyce, Professor of Pathology in University College, Liverpool; and W. A. Herdman, Professor of Zoology in University College, Liverpool,

exists for the recent 'Oyster and typhoid' scare, (a) in the interests of the oyster fisheries, and (b) in the interests of the general public.

A. The objects, in detail, we had in view in entering on the investigation were as follows:—

1. To determine the conditions of life and health and growth of the oyster by keeping samples in sea waters of different composition—*e.g.*, it is a matter of discussion amongst practical ostreiculturists as to what specific gravity or salinity of water, and what amount of lime are best for the due proportionate growth of both shell and body.

2. To determine the effect of feeding oysters on various substances—both natural food, such as Diatoms, and artificial food, such as oatmeal. Here, again, there is a want of agreement at present as to the benefit or otherwise of feeding oysters in captivity.

3. To determine the effect of adding various impurities to the water in which the oysters are grown, and especially the effect of sewage in various quantities. It is notorious that oysters are frequently grown or laid down for fattening purposes in water which is more or less contaminated by sewage, but it is still an open question as to the resulting effect upon the oyster.

4. To determine whether oysters not infected with a pathogenic organism, but grown under insanitary conditions, have a deleterious effect when used as food by animals.

5. To determine the effect upon the oyster of infection with typhoid, both naturally—*i.e.*, by feeding with sewage water containing typhoid stools, and artificially—*i.e.*, by feeding on a culture in broth of the typhoid organism.

6. To determine the fate of the typhoid bacillus in the oyster—whether it is confined to the alimentary canal, and whether it increases in any special part or gives rise

to any diseased conditions; how long it remains in the alimentary canal; whether it remains and grows in the pallial cavity, on the surface of the mantle and branchial folds; and whether it produces any altered condition of these parts that can be recognized by the eye on opening the oyster.

7. To determine whether an oyster can free its alimentary canal and pallial cavity from the typhoid organism when placed in a stream of clean sea water; and, if so, how long would be required, under average conditions, to render infected oysters practically harmless.

B. The methods which we employed in attaining these objects were as follows:—

1. Observations upon oysters laid down in the sea, at Port Erin—

(a) Sunk in 5 fathoms in the bay, in pure water.

(b) Deposited in shore pool, but in clean water.

(c) Laid down in three different spots in more or less close proximity to the main drain pipe, opening into the sea below low-water mark.

These were to ascertain differences of fattening, condition, mortality, and the acquisition of deleterious properties as the result of sewage contamination.

2. Observations upon oysters subjected to various abnormal conditions in the laboratory.*

(a) A series of oysters placed in sea water and allowed to stagnate, in order to determine effect of non-aëration.

(b) Similar series in water kept periodically aërated.

(c) A series placed in sea water to which a given quantity of fresh (tap) water was added daily, to determine effect of reduction of salinity.

*The oysters were kept in basins in cool rooms of constant temperature, shaded from the sun, both at the Port Erin Biological Station and also in the Pathological and Zoölogical Laboratories at University College, Liverpool.

(d) A series of oysters weighed approximately, and fed upon the following substances, viz.:—

(1) Oatmeal.

(2) Flour.

(3) Sugar.

(4) Broth.

(5) Living Protophyta (Diatoms, Desmids, Algeæ).

(6) Living Protozoa (Infusoria, etc.).

(7) Earth.

In this series of experiments the oysters were fed every morning and the water aërated, but not changed (evaporation was compensated for by the addition of a little tap water as required). The oysters were weighed from time to time, and observations made upon the apparently harmful or beneficial effects of the above methods of treatment.

(e) A series of oysters placed in sea water to which was added daily—

(1) Healthy faecal matter.

(2) Typhoid faecal matter.

(3) Pure cultivations of the typhoid bacillus.

The oysters were carefully examined to determine their condition, with special reference to condition of branchia, alimentary canal, adductor muscle, and viscera generally. The contents of the rectum, as well as the water in the pallial cavity, were subjected to bacteriological analysis to determine the number of micro-organisms present, as well as the identity of the typhoid or other pathogenic organisms.

C. The following is a summary of the results obtained so far:—

We consider that these results are based upon tentative experiments, and serve only to indicate further any definite lines of research. They must not be regarded as conclusive. We feel strongly that all the experiments must be repeated and extended in several directions.

Our experiments demonstrate:—

I. The beneficial effects of aëration—

(a) By the addition of air only;

(b) By change of water;

pointing to the conclusion that the laying down of oysters in localities where there is a good change of water, by tidal current or otherwise, should be beneficial.

II. The diverse results obtained by feeding upon various substances, amongst which the following may be noted. The exceedingly harmful action of sugar, which caused the oysters to decrease in weight and die; whilst the other substances detailed above enabled them to maintain their weight or increase. The oysters thrive best upon the living Protophyta and Protozoa. Those fed upon oatmeal and flour after a time sickened and eventually died.

III. The deleterious effects of stagnation, owing to the collection of excretory products, growth of micro-organisms, and formation of scums upon the surface of the water.

IV. The toleration of sewage, etc. It was found that oysters could, up to a certain point, render clear sewage-contaminated water, and that they could live for a prolonged period in water rendered completely opaque by the addition of faecal matter; that the faecal matter obtained from cases of typhoid was more inimical than that obtained from healthy subjects; and that there was considerable toleration to peptonised broth.

V. The infection of the oyster by the micro-organisms. The results of the bacteriological examination of the water of the pallial cavity of the oyster, and of the contents of the rectum, showed that in the cases of those laid down in the open water of the bay the colonies present were especially small in number, whilst in those laid down in proximity to the drain pipe the number was enormous (*e. g.*, 17,000 as against 10 in the former case). It was found that more organisms were present in

the pallial cavity than in the rectum. In the case of the oysters grown in water infected with the *Bacillus typhosus*, it was found that there was no apparent increase of the organisms, but that they could be identified in cultures taken from the water of the pallial cavity and rectum fourteen days after infection.

It is found that the typhoid bacillus will not flourish in clean sea water, and our experiments seem to show so far that it decreases in numbers in its passage along the alimentary canal of the oyster. It would seem possible, therefore, that by methods similar to those employed in the 'Bassins de dégorge ment' of the French ostreiculturist, where the oysters are carefully subjected to a natural process of cleaning, oysters previously contaminated with sewage could be freed of pathogenic organisms or their products without spoiling the oyster for the market.

It need scarcely be pointed out that if it becomes possible thus to cleanse infected or suspected oysters by a simple mode of treatment which will render them innocuous, a great boon will have been conferred upon both the oyster trade and the oyster-consuming public.

We desire to acknowledge the kind help of Mr. W. I. Beaumont in making some of the observations at Port Erin, and of Mr. Andrew Scott at Liverpool.

ADDRESS OF THE PRESIDENT, SIR DOUGLAS GALTON, BEFORE THE BRITISH ASSOCIATION FOR THE ADVANCEMENT OF SCIENCE (II.).

THE earliest Reports of the Association which bear on the biological sciences were those relating to botany. In 1831 the controversy was yet unsettled between the advantages of the Linnæan, or Artificial system, as contrasted with the Natural system of classification. Histology, morphology, and physiological botany, even if born, were

in their early infancy. Our records show that von Mohl noted cell division in 1835, the presence of chlorophyll corpuscles in 1837; and he first described protoplasm in 1846.

In 1831 Cuvier, who, during the previous generation had, by the collation of facts followed by careful inductive reasoning, established the plan on which each animal is constructed, was approaching the termination of his long and useful life. He died in 1832; but in 1831 Richard Owen was just commencing his anatomical investigations and his brilliant contributions to paleontology. The impulse which their labors gave to biological science was reflected in numerous reports and communications, by Owen and others throughout the early decades of the British Association, until Darwin propounded a theory of evolution which commanded the general assent of the scientific world. For this theory was not absolutely new. But just as Cuvier had shown that each bone in the fabric of an animal affords a clue to the shape and structure of the animal, so Darwin brought harmony into scattered facts, and led us to perceive that the moulding hand of the Creator may have evolved the complicated structures of the organic world from one or more primeval cells.

Richard Owen did not accept Darwin's theory of evolution, and a large section of the public contested it. I well remember the storm it produced—a storm of praise by my geological colleagues, who accepted the result of investigated facts; a storm of indignation such as that which would have burned Galileo at the stake from those who were not yet prepared to question the old authorities; but they diminished daily. We are, however, as yet only on the threshold of the doctrine of evolution. Does not each fresh investigation, even into the embryonic stage of the simpler forms of life, suggest fresh problems?

The impulse given by Darwin has been fruitful in leading others to consider whether the same principle of evolution may not have governed the moral as well as the material progress of the human race. Mr. Kidd tells us that nature as interpreted by the struggle for life contains no sanction for the moral progress of the individual, and points out that if each of us were allowed by the conditions of life to follow his own inclination the average of each generation would distinctly deteriorate from that of the preceding one; but because the law of life is ceaseless and inevitable struggle and competition, ceaseless and inevitable selection and rejection, the result is necessarily ceaseless and inevitable progress.

Evolution, as Sir William Flower said, is the message which biology has sent to help us on with some of the problems of human life, and Francis Galton urges that man, the foremost outcome of the awful mystery of evolution, should realize that he has the power of shaping the course of future humanity by using his intelligence to discover and expedite the changes which are necessary to adapt circumstances to man, and man to circumstances.

In considering the evolution of the human race, the science of preventive medicine may afford us some indication of the direction in which to seek for social improvement. One of the early steps towards establishing that science upon a secure basis was taken in 1835 by the British Association, who urged upon the Government the necessity of establishing registers of mortality showing the causes of death "on one uniform plan in all parts of the King's dominions, as the only means by which general laws touching the influence of causes of disease and death could be satisfactorily deduced." The general registration of births and deaths was commenced in 1838. But a mere record of death and

its proximate cause is insufficient. Preventive medicine requires a knowledge of the details of the previous conditions of life and of occupation. Moreover, death is not our only or most dangerous enemy, and the main object of preventive medicine is to ward off disease. Disease of body lowers our useful energy. Disease of body or of mind may stamp its curse on succeeding generations.

The anthropometric laboratory affords to the student of anthropology a means of analyzing the causes of weakness, not only in bodily, but also in mental life. Mental actions are indicated by movements and their results. Such signs are capable of record, and modern physiology has shown that bodily movements correspond to action in nerve centers, as surely as the motions of the telegraph indicator express the movements of the operator's hands in the distant office.

Thus there is a relation between a defective *status* in brain power and defects in the proportioning of the body. Defects in physiognomical details, too finely graded to be measured with instruments, may be appreciated with accuracy by the senses of the observer; and the records show that these defects are in a large degree associated with a brain *status* lower than the average in mental power. A report presented by one of your committees shows that about 16 per 1,000 of the elementary school population appear to be so far defective in their bodily or brain condition as to need special training to enable them to undertake the duties of life and to keep them from pauperism or crime. Many of our feeble-minded children, and much disease and vice, are the outcome of inherited proclivities. Francis Galton has shown us that types of criminals which have been bred true to their kind are one of the saddest disfigurements of modern civilization; and he says that few deserve better of their country

than those who determine to lead celibate lives through a reasonable conviction that their issue would probably be less fitted than the generality to play their part as citizens.

These considerations point to the importance of preventing those suffering from transmissible disease, or the criminal or the lunatic, from adding fresh sufferers to the teeming misery in our large towns. And in any case, knowing as we do the influence of environment on the development of individuals, they point to the necessity of removing those who are born with feeble minds or under conditions of moral danger from surrounding deteriorating influences. These are problems which materially affect the progress of the human race, and we may feel sure that, as we gradually approach their solution, we shall more certainly realize that the theory of evolution, which the genius of Darwin impressed on this century, is but the first step on a biological ladder which may possibly eventually lead us to understand how in the drama of creation man has been evolved as the highest work of the Creator.

The sciences of medicine and surgery were largely represented in the earlier meetings of the Association, before the creation of the British Medical Association afforded a field for their more intimate discussion. The close connection between the different branches of science is causing a revival in our proceedings of discussions on some of the highest medical problems, especially those relating to the spread of infectious and epidemic disease. It is interesting to contrast the opinion prevalent at the foundation of the Association with the present position of the question. A report to the Association in 1834, by Professor Henry, on contagion, says: "The notion that contagious emanations are at all connected with the diffusion of animalculæ through the atmosphere is at variance with all that

is known of the diffusion of volatile contagion."

Whilst it had long been known that filthy conditions in air, earth and water fostered fever, cholera and many other forms of disease, and that the disease ceased to spread on the removal of these conditions, yet the reason for their propagation or diminution remained under a veil.

Leeuwenhoek in 1680 described the yeast-cells, but Schwann in 1837 first showed clearly that fermentation was due to the activity of the yeast-cells; and, although vague ideas of fermentation had been current during the past century, he laid the foundation of our exact knowledge of the nature of the action of ferments, both organized and unorganized. It was not until 1860, after the prize of the Academy of Sciences had been awarded to Pasteur for his essay against the theory of spontaneous generation, that his investigations into the action of ferments enabled him to show that the effects of the yeast-cell are indissolubly bound up with the activities of the cell as a living organism, and that certain diseases, at least, are due to the action of ferments in the living being. In 1865 he showed that the disease of silkworms, which was then undermining the silk industry in France, could be successfully combated. His further researches into anthrax, fowl cholera, swine fever, rabies and other diseases proved the theory that those diseases are connected in some way with the introduction of a microbe into the body of an animal; that the virulence of the poison can be diminished by cultivating the microbes in an appropriate manner; and that when the virulence has been thus diminished their inoculation will afford a protection against the disease.

Meanwhile it had often been observed in hospital practice that a patient with a simple-fractured limb was easily cured, whilst a patient with a compound fracture

often died from the wound. Lister was thence led, in 1865, to adopt his antiseptic treatment, by which the wound is protected from hostile microbes. These investigations, followed by the discovery of the existence of a multitude of micro-organisms and the recognition of some of them—such as the bacillus of tubercle and the comma bacillus of cholera—as essential factors of disease, and by the elaboration by Koch and others of methods by which the several organisms might be isolated, cultivated, and their histories studied, have gradually built up the science of bacteriology. Amongst later developments are the discovery of various so-called antitoxins, such as those of diphtheria and tetanus, and the utilization of these for the cure of disease. Lister's treatment formed a landmark in the science of surgery, and enabled our surgeons to perform operations never before dreamed of; whilst later discoveries are tending to place the practice of medicine on a firm scientific basis.

The study of bacteriology has shown us that, although some of these organisms may be the accompaniments of disease, yet we owe it to the operation of others that the refuse caused by the cessation of animal and vegetable life is reconverted into food for fresh generations of plants and animals. These considerations have formed a point of meeting where the biologist, the chemist, the physicist and the statistician unite with the sanitary engineer in the application of the science of preventive medicine.

The early reports to the Association show that the laws of hydrostatics, hydrodynamics and hydraulics necessary to the supply and removal of water through pipes and conduits had long been investigated by the mathematician. But the modern sanitary engineer has been driven by the needs of an increasing population to call in the chemist and the biologist to help him to provide pure water and pure air. The

purification and the utilization of sewage occupied the attention of the British Association as early as 1864, and between 1869 and 1876 a committee of the Association made a series of valuable reports on the subject. It was not till the chemist called to his aid the biologist, and came to the help of the engineer, that a scientific system of sewage purification was evolved.

Dr. Frankland many years ago suggested the intermittent filtration of sewage; and Mr. Baldwin Latham was one of the first engineers to adopt it. But the valuable experiments made in recent years by the State Board of Health in Massachusetts have more clearly explained to us how by this system we may utilize micro-organisms to convert organic impurity in sewage into food fitted for higher forms of life. To effect this we require, in the first place, a filter of any material which affords numerous surfaces or open pores. Secondly, that after a volume of sewage has passed through the filter an interval of time be allowed, in which the air necessary to support the life of the micro-organisms is enabled to enter the pores of the filter. Thus this system is dependent upon oxygen and time. Under such conditions the organisms necessary for purification are sure to establish themselves in the filter before it has been long in use.

In other branches of civil and mechanical engineering the reports in 1831 and 1832 on the state of this science show that the theoretical and practical knowledge of the strength of timber had obtained considerable development. But in 1830, before the introduction of railways, cast iron had been sparingly used in arched bridges for spans of from 160 to 200 feet, and wrought iron had only been applied to large-span iron bridges on the suspension principle, the most notable instance of which was the Menai suspension bridge, by Telford.

The development of the iron industry is

due to the association of the chemist with the engineer. The introduction of the hot blast by Neilson, in 1829, in the manufacture of cast iron had effected a large saving of fuel. But the chemical conditions which affect the strength and other qualities of iron, and its combination with carbon, silicon, phosphorus and other substances had at that time scarcely been investigated. In 1856 Bessemer brought before the British Association at Cheltenham his brilliant discovery for making steel direct from the blast furnace. This discovery, followed by Siemens's regenerative furnace, by Whitworth's compressed steel, and by the use of alloys and by other improvements too numerous to mention here, has revolutionized the conditions under which metals are applied to engineering purposes.

Indeed, few questions are of greater interest, or possess more industrial importance, than those connected with metallic alloys. This is especially true of those alloys which contain the rarer metals; and the extraordinary effects of small quantities of chromium, nickel, tungsten and titanium on certain varieties of steel have exerted profound influence on the manufacture of projectiles and on the construction of our armored ships. Of late years investigations on the properties and structure of alloys have been numerous, and among the more noteworthy researches may be mentioned those of Dewar and Fleming on the distinctive behavior, as regards the thermo-electric powers and electrical resistance, of metals and alloys at the very low temperatures which may be obtained by the use of liquid air.

Professor Roberts-Austen, on the other hand, has carefully studied the behavior of alloys at very high temperatures, and by employing his delicate pyrometer has obtained photographic curves which afford additional evidence as to the existence of allotropic modifications of metals, and which

have materially strengthened the view that alloys are closely analogous to saline solutions. Professor Roberts-Austen has, moreover, shown that the effect of any one constituent of an alloy upon the properties of the principal metal has a direct relation to the atomic volumes, and that it is consequently possible to fortell, in a great measure, the effect of any given combination.

Metallurgical science has brought aluminium into use by cheapening the process of its extraction; and if by means of the wasted forces in our rivers, or possibly of the wind, the extraction be still further cheapened by the aid of electricity, we may not only utilize the metal or its alloys in increasing the spans of our bridges, and in affording strength and lightness in the construction of our ships, but we may hope to obtain a material which may render practicable the dreams of Icarus and of Maxim, and for purposes of rapid transit enable us to navigate the air.

As early as 1820 the steam engine had been applied by Gurney, Hancock and others to road traction. The absurd impediments placed in their way by road trustees, which, indeed, are still enforced, checked any progress. But the question of mechanical traction on ordinary roads was practically shelved in 1830, at the time of the formation of the British Association, when the locomotive engine was combined with a tubular boiler and an iron road on the Liverpool and Manchester Railway. Great, however, as was the advance made by the locomotive engine of Robert Stephenson, these earlier engines were only toys compared with the compound engines of to-day which are used for railways, for ships, or for the manufacture of electricity. Indeed, it may be said that the study of the laws of heat, which have led to the introduction of various forms of motive power, are gradually revolutionizing all our habits of life.

The improvements in the production of

iron, combined with the developed steam engine, have completely altered the conditions of our commercial intercourse on land; whilst the changes caused by the effects of these improvements in shipbuilding and on the ocean carrying trade have been, if anything, still more marked. At the foundation of the Association all ocean ships were built by hand of wood, propelled by sails, and manœuvred by manual labor; the material limited their length, which did not often exceed 100 ft., and the number of English ships of over 500 tons burden was comparatively small. In the modern ships steam power takes the place of manual labor. It rolls the plates of which the ship is constructed, bends them to the required shapes, cuts, drills, and rivets them in their place. It weighs the anchor; it propels the ship in spite of winds or currents; it steers, ventilates and lights the ship when on the ocean. It takes the cargo on board and discharges it on arrival.

The use of iron favors the construction of ships of a large size, of forms which afford small resistance to the water, and with compartments which make the ships practically unsinkable in heavy seas or by collision. Their size, the economy with which they are propelled, and the certainty of their arrival, cheapen the cost of transport. The steam engine, by compressing air, gives us control over the temperature of cool chambers. In these not only fresh meat, but the delicate produce of the Antipodes, is brought across the ocean to our doors without deterioration. Whilst railways have done much to alter the social conditions of each individual nation, the application of iron and steam to our ships is revolutionizing the international commercial conditions of the world; and it is gradually changing the course of our agriculture as well as of our domestic life.

But, great as have been the developments of science in promoting the commerce of the

world, science is asserting its supremacy even to a greater extent in every department of war. And perhaps this application of science affords at a glance, better than almost any other, a convenient illustration of the assistance which the chemical, physical and electrical sciences are affording to the engineer. The reception of warlike stores is not now left to the uncertain judgment of 'practical men,' but is confided to officers who have received a special training in chemical analysis and in the application of physical and electrical science to the tests by which the qualities of explosives, of guns and of projectiles can be ascertained. For instance, take explosives. Till quite recently black and brown powders alone were used—the former as old as civilization, the latter but a small modern improvement adapted to the increased size of guns. But now the whole family of nitro-explosives are rapidly superseding the old powder. These are the direct outcome of chemical knowledge and not of random experiment. The construction of guns is no longer a haphazard operation. In spite of the enormous forces to be controlled and the sudden violence of their action, the researches of the mathematician have enabled the just proportions to be determined with accuracy; the labors of the physicist have revealed the internal conditions of the materials employed and the best means of their favorable employment. The chemist has rendered it clear that even the smallest quantities of certain ingredients are of supreme importance in affecting the tenacity and trustworthiness of the materials. The treatment of steel to adapt it to the vast range of duties it has to perform is thus the outcome of patient research. And the use of the metals—manganese, chromium, nickel, molybdenum—as alloys with iron has resulted in the production of steels possessing varied and extraordinary properties. The steel required to resist the

conjugate stresses developed, lightning fashion, in a gun necessitates qualities that would not be suitable in the projectile which that gun hurls with a velocity of some 2,500 ft. per second against the armored side of a ship.

The armor, again, has to combine extreme superficial hardness with great toughness, and during the last few years these qualities are sought to be attained by the application of the cementation process for adding carbon to one face of the plate and hardening that face alone by rapid refrigeration. The introduction of metal cartridge-cases of complex forms drawn cold out of solid blocks or plate has taxed the ingenuity of the mechanic in the device of machinery and of the metallurgist in producing a metal possessed of the necessary ductility and toughness. The cases have to stand a pressure at the moment of firing of as much as 25 tons to the square inch. There is nothing more wonderful in practical mechanics than the closing of the breech openings of guns, for not only must they be gas-tight at these tremendous pressures, but such that one man by a single continuous movement shall be able to open or close the breech of the largest gun in some ten or 15 seconds. The perfect knowledge of the recoil of guns has enabled the reaction of the discharge to be utilized in compressing air or springs by which guns can be raised from concealed positions in order to deliver their fire, and then made to disappear again for loading, or the same force has been used to run up the guns automatically immediately after firing, or, as in the case of the Maxim gun, to deliver in the same way a continuous stream of bullets at the rate of ten in one second.

In every department concerned in the production of warlike stores electricity is playing a more and more important part. It has enabled the passage of a shot to be followed from its seat in the gun to its

destination. In the gun, by means of electrical contacts arranged in the bore, a time-curve of the passage of the shot can be determined. From this the mathematician constructs the velocity-curve, and from this again the pressures producing the velocity are estimated and used to check the same indications obtained by other means. Electricity and photography have been laid under contribution for obtaining records of the flight of projectiles and the effects of explosions at the moment of their occurrence. Many of you will recollect Mr. Vernon Boys's marvelous photographs showing the progress of the shot driving before it waves of air in its course. The readiness with which electrical energy can be converted into heat or light has been taken advantage of for the firing of guns, which in their turn can, by the same agency, be laid on the object by means of range finders placed at a distance and in advantageous and safe positions; while the electric light is utilized to illumine the sights at night, as well as to search out the objects of attack.

The advances in engineering which have produced the steam engine, the railway, the telegraph, as well as our engines of war, may be said to be the result of commercial enterprise rendered possible only by the advances which have taken place in the several branches of science since 1831. Having regard to the intimate relations which the several sciences bear to each other, it is abundantly clear that much of this progress could not have taken place in the past, nor could further progress take place in the future, without intercommunication between the students of different branches of science. The founders of the British Association based its claims to utility upon the power it afforded for this intercommunication. Mr. Vernon Harcourt (the uncle of your present General Secretary), in the address he delivered in 1832, said: "How feeble is man for any purpose

when he stands alone—how strong when united with other men! It may be true that the greatest philosophical works have been achieved in privacy, but it is no less true that these works would never have been accomplished had the authors not mingled with men of corresponding pursuits, and from the commerce of ideas often gathered germs of apparently isolated discoveries, and without such material aid would seldom have carried their investigations to a valuable conclusion."

I claim for the British Association that it has fulfilled the objects of its founders, that it has had a large share in promoting intercommunication and combination. Our meetings have been successful because they have maintained the true principles of scientific investigation. We have been able to secure the continued presence and concurrence of the master spirits of science. They have been willing to sacrifice their leisure, and to promote the welfare of the Association, because the meetings have afforded them the means of advancing the sciences to which they are attached.

The Association has, moreover, justified the views of its founders in promoting intercourse between the pursuers of science, both at home and abroad, in a manner which is afforded by no other agency. The weekly and sessional reunions of the Royal Society, and the annual *soirées* of other scientific societies, promote this intercourse to some extent, but the British Association presents to the young student during its week of meetings easy and continuous social opportunities for making the acquaintance of leaders in science, and thereby obtaining their directing influence. It thus encourages, in the first place, opportunities of combination, but, what is equally important, it gives at the same time material assistance to the investigators whom it thus brings together. The reports on the state of science at the present time, as they ap-

pear in the last volume of our Transactions, occupy the same important position, as records of science progress, as that occupied by those reports in our earlier years. We exhibit no symptom of decay.

Our neighbors and rivals rely largely upon the guidance of the State for the promotion of both science teaching and of research. In Germany the foundations of technical and industrial training are laid in the Realschulen and supplemented by the higher technical schools. In Berlin that splendid institution, the Royal Technical High School, casts into the shade the facilities for education in the various Polytechnics which we are now establishing in London.

For developing pure scientific research and for promoting new applications of science to industrial purposes the German Government, at the instance of von Helmholtz and aided by the munificence of Werner von Siemens, created the *Physikalische Technische Reichsanstalt* at Charlottenburg. This establishment consists of two divisions. The first is charged with pure research, and is at the present time engaged in various thermal, optical, and electrical and other physical investigations. The second branch is employed in operations of delicate standardizing to assist the wants of research students. As a consequence of the position which science occupies in connection with the State in Continental countries, the services of those who have distinguished themselves either in the advancement or in the application of science are recognized by the award of honors; and thus the feeling for science is encouraged throughout the nation.

Great Britain maintained for a long time a leading position among the nations of the world by virtue of the excellence and accuracy of its workmanship, the result of individual energy; but the progress of mechanical science has made accuracy of work-

manship the common property of all nations of the world. Our records show that hitherto, in its efforts to maintain its position by the application of science and the prosecution of research, England has made marvellous advances by means of voluntary effort, illustrated by the splendid munificence of such men as Gassiot, Joseph Whitworth, James Mason and Ludwig Mond; and, whilst the increasing field of scientific research compels us occasionally to seek for Government assistance, it would be unfortunate if by any chance voluntary effort were fettered by State control. The British Association has contributed £60,000 to aid research since its formation.

The other voluntary agencies to research, including those which the Government carries on for its own purposes, are too numerous to print here. For direct assistance to voluntary effort the Treasury contributes £4,000 a year to the Royal Society for the promotion of research, which is administered under a board whose members represent all branches of science. The Treasury, moreover, contributes to marine biological observatories, and in recent years has defrayed the cost of various expeditions for biological and astronomical research, which in the case of the Challenger expedition involved very large sums of money. In addition to these direct aids to science, Parliament, under the Local Taxation Act, handed over to the County Councils a sum, which amounted in the year 1893 to £615,000, to be expended on technical education. In many country districts, so far as the advancement of real scientific technical progress in the nation is concerned, much of this money has been wasted for want of knowledge. And whilst it cannot be said that the Government or Parliament have been indifferent to the promotion of scientific education and research, it is a source of regret that the Government did not devote some small portion of this magnificent gift

to affording an object lesson to County Councils in the application of science to technical instruction, which would have suggested the principles which would most usefully guide them in the expenditure of this public money. Government assistance to science has been based mainly on the principle of helping voluntary effort.

The Kew Observatory was initiated as a scientific observatory by the British Association. It is now supported by the Gassiot trust fund, and managed by the incorporated Kew Observatory Committee of the Royal Society. This institution carries on to a limited extent some small portion of the class of work done in Germany by that magnificent institution, the Reichsanstalt at Charlottenburg, but its development is fettered by want of funds. British students of science are compelled to resort to Berlin and Paris when they require to compare their more delicate instruments and apparatus with recognized standards. There could scarcely be a more advantageous addition to the assistance which Government now gives to science than for it to allot a substantial annual sum to the extension of the Kew Observatory, in order to develop it on the model of the Reichsanstalt.

The various agencies for scientific education have produced numerous students admirably qualified to pursue research; and at the same time almost every field of industry presents openings for improvement through the development of scientific methods. For instance, agricultural operations alone offer openings for research to the biologist, the chemist, the physicist, the geologist, the engineer, which have hitherto been largely overlooked. If students do not easily find employment it is chiefly attributable to a want of appreciation for science in the nation at large. This want of appreciation appears to arise from the fact that those who nearly half a century ago directed the movement of national education were

trained in early life in the universities, in which the value of scientific methods was not at that time fully recognized. Hence our elementary and even our secondary and great public schools neglected for a long time to encourage the spirit of investigation which develops originality. This defect is diminishing daily.

There is, however, a more intangible cause which may have had influence on the want of appreciation of science by the nation. The Government, which largely profits by science, aids it with money, but it has done very little to develop the national appreciation for science by recognizing that its leaders are worthy of honors conferred by the State. Science is not fashionable, and science students—upon whose efforts our progress as a nation so largely depends—have not received the same measure of recognition which the State awards to services rendered by its own officials, by politicians, and by the Army and by the Navy, whose success in future wars will largely depend on the effective applications of science.

The reports of the British Association afford a complete chronicle of the gradual growth of scientific knowledge since 1831. They show that the Association has fulfilled the objects of its founders in promoting and disseminating a knowledge of science throughout the nation. The growing connection between the sciences places our annual meeting in the position of an arena where representatives of the different sciences have the opportunity of criticizing new discoveries and testing the value of fresh proposals, and the presidential and sectional addresses operate as an annual stock-taking of progress in the several branches of science represented in the sections. Every year the field of usefulness of the Association is widening. For, whether with the geologist we seek to write the history of the crust of the earth, or with the

biologist to trace out the evolution of its inhabitants, or whether with the astronomer, the chemist and the physicist we endeavor to unravel the constitution of the sun and the planets or the genesis of the nebulae and stars which make up the universe, on every side we find ourselves surrounded by mysteries which await solution. We are only at the beginning of work.

I have, therefore, full confidence that the future records of the British Association will chronicle a still greater progress than that already achieved, and that the British

eral lake-like expanses usually represented as being at the head of some very small stream, I began inquiries concerning them and followed this up by visiting several of the largest.

Parenthetically, I may say that Darlington is well out on the loose sands and clays of the coastal plain (see Fig. 1), and while the main streams have cut down 30 to 40 feet beneath the general level of the country, yet their side streamlets are small, and much of the inter-stream surface is poorly dissected and but slightly changed from



Fig. 1. Map of S. C., showing position of Darlington on the coastal plain.

nation will maintain its leading position amongst the nations of the world, if it will energetically continue its voluntary efforts to promote research, supplemented by that additional help from the Government which ought never to be withheld when a clear case of scientific utility has been established.

SOME NOTES ON DARLINGTON (S. C.), 'BAYS.'

HAVING noted on a surveyor's map of my school district of Darlington, S. C., sev-

the condition in which it was uplifted from sea bottom. This inter-stream surface is very level, the slope being about one foot per mile; the streamlets are weak; and extensive systems of ditches are necessary to keep the upland drained for cultivation.

To the lake-like expanses the term 'bay' is usually applied, and by it is meant a perfectly flat, clayey area with a surface some two to four feet below the general level of the country and varying from a few acres in size to stretches a mile or two long and a

half mile or more in width; the smaller ones being much more numerous and having usually an area of 20 to 30 acres. They are in some cases approximately round in shape, though they are usually ovoid or el-

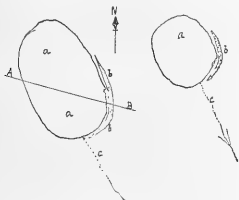

Fig. 2. Sketch map of a 'bay.' a, 'bay'; b, sand ridge; c, intermittent outflow to a stream near by.

liptical (see Fig. 2), and are covered with vegetation-stained water from a few inches to a foot or two deep, according to the season. Growing in this water, where the 'bay' is uncleared, are cypress, juniper or black-gum trees with a moderately thick swamp undergrowth.

Except when overflowed in a rainy season, there is often in the smaller 'bays' no permanent drainage. In the larger ones a small streamlet usually rises. When cleared for cultivation, the first requisite is to dig a ditch to the nearest stream or main ditch sufficiently deep for thorough drainage.

A sand ridge borders each 'bay' on the east and southeast and sometimes extends fairly well round toward the south, but is never found, so far as I could ascertain, on the west or north (see Fig. 2, b). The size of this sand ridge varies with the size of the 'bay,' rising in some well-pronounced cases 5 or 6 feet above the general level in the highest part and thinning out near both ends. In the usual case, however, it rises only some 2 or 3 feet above the general surface level. The width of the ridge varies from a rod to three or four rods. The

transverse surface curvature is most often uniform, or if more precipitous on one side than on the other no law could be found governing such variation (see Fig. 3).

A gentleman owning large tracts of land containing 'bays,' and having been a close observer of them, gave me much information and went a number of times to visit them with me. He called my attention to the fact that on first attempting to drain them for cultivation he had tried cutting ditches through this sand ridge, but found that the sand caved so easily (being, in a few cases, very quick) that it was very difficult to dig and keep such ditches open. The sand I thus found extended down below the surface of the adjacent sands and clays. How deep I could not find by direct test, probably not deeper at farthest than 15 to 25 feet, if nearly as deep as that, which I doubt. It is a rounded sand and, though used in Darlington for mortar, is very poor for building purposes. No fossils could be found in it so far as I searched. No stratification was visible. It is agriculturally extremely poor, and from its characteristic whiteness may be detected

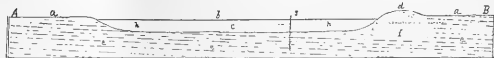

Fig. 3. Section 'through a bay' on line A B in Fig. 2. A B, general surface level; b, surface of 'bay'; c, clay filling basin of 'bay'; d, sand ridge; e, loose sands and clays dipping gently southeast; f, unknown part; g, pump; h, water level.

in a field that has been tilled for years. It seems to be a beach sand.

The basin (see Fig. 3, c) when drained shows a dark fertile, compact clay, impervious to water and with no fossils so far as a rough search could detect. This clay extends down some 15 to 25 feet, as is proved by driven wells that have been forced down through it. No water is got-

ten until the pipe reaches the underlying sand, when the water at once rises to the general water level, within 6 or 8 ft. of the surface. (See Fig. 3, g and h.)

Other duties prevented my mapping the large number of 'bays' that occur, to see what relationship, if any, could be discovered from their position. They seem to be scattered irregularly over the flat surface, some nearer the present coast than others. Whether they arrange themselves along certain lines I cannot say.

By some the sand ridges are attributed to wind action. This, however, would require a region free of vegetation, and we do not know that this one ever was so over any broad area. Besides, the wind would pile the dunes on *other sides* of the 'bays' than the east and southeast, unless it blew always from the east or southeast—a supposition of which no proof can be given. Finally, wind action is insufficient to account for the bases of the sand ridges extending beneath the general surface of the adjacent sands and clays.

From an examination of the Coast Survey charts of the Albemarle and Pamlico Sound region, I was at first led to conclude that I had in the 'bays' the results of numerous repetitions on a smaller scale of what is now going on in these sounds—the difference in the *size* of the bodies compared being great, but their agreement in *process* being strong. Each sound is a drowned valley with a bottom 15 to 25 feet deep at most and, being cut off from the ocean by the sand bar thrown across its mouth, they are slowly silting up with the very fine material brought down by the sluggish streams that empty into them. If present conditions continue long enough they will be filled with a fine, compact clay, and are already skirted on the southwest and east by a sand dune. There is an apparent analogy. The former sea where Darlington now stands—though deep shortly before

this from the thick beds of fuller's earth which must have been very gently deposited far from shore sands—was shallow, as is shown by the marl deposits near the surface and by the sands over all the region showing false or cross bedding and containing in some places moderate sized quartz pebbles. The shore line must have been low. Streams were probably numerous and small, no large drainage basins having been formed. Allow time enough for a little cutting of their channels by these newly-born streams, then a very small downward oscillation of the land,* let the headlands be beaten off and bars thrown across the mouth of the drowned streams while the enclosed basin slowly fills with fine sediment, and finally let the whole region gradually rise as it has done in fact, and we have a theory of their origin (see Fig. 4).



Fig. 4. *Theoretic Origin.* a, soundlet being enclosed; b, headlands beaten-back; c, bar thrown across mouth of sound.

This theory, however, is open to certain objections. No remains of an old stream channel entering this 'bay' is found. The existence of old beaten-off headlands on either side has been asked about. If these exist they are too faint to have made themselves noticeable when not looked for. They may exist in the case of the larger ones. The irregular distribution toward

*See Prof. Shaler's 'Fresh Water Morasses, etc,' 10th An. Rept. U. S. Geol. Sur., pp. 330-331, for numerous such oscillations recorded near this region.

the present shore is another difficulty. The prevailing rounded or elliptical shape is not explained.

That the sea, when this part of the coastal plain rose above it, left numerous inequalities somewhat similar to the ripple-made pittings seen in the sand in the bottom of a gutter after a rain has suggested itself to me. If so, these basin-like pittings—separated from each other by sand ridges highest above the general shore slope on their east side—might have formed the basins for these 'bays.'

Fuller observation and study is needed before anything but a tentative conclusion may be reached. Any additional observations or suggestions will be gladly welcomed.

L. C. GLENN.

DARLINGTON, S. C.

—
A NEW METHOD OF DETERMINING THE MOTION OF STARS IN THE LINE OF SIGHT.

A METHOD of measuring the motions of stars in the line of light, which does not require the use of an artificial comparison spectrum, and which is therefore adapted to slitless spectroscopes, has been proposed by Professor Orbinsky, of Odessa (*A. N.* 3289). It is of unusual interest because the object-glass spectroscope, which is so advantageous with respect to simplicity of construction and to the brightness of the spectra which it yields, has never yet been successfully applied to this branch of astronomical research.

The principles on which the method depends may be briefly described as follows: If a luminous body is moving in the line of sight, the distance between any two lines in its spectrum is not what it would be if the body were at rest, since the two lines are unequally displaced by the motion. In a normal spectrum the displacement of the lower line would be somewhat the greater, although the differ-

ence would scarcely be measurable under ordinary circumstances, but on account of the increasing dispersion of a prism toward the violet the effect in a prismatic spectrum is reversed, and the upper line is displaced more than the lower one. The differential displacement of the $H\delta$ and $H\beta$ -lines, in an ordinary prismatic spectroscope, is, in fact, somewhat more than half the absolute displacement of the $H\gamma$ line. By measuring this apparent change of dispersion the motion of a star can be determined.

To avoid the errors attending the measurement of large distances on a photograph, and other errors which need not be specially mentioned here, the spectrum of a star whose motion in the line of sight is known is photographed on the same plate, and the apparent change of dispersion due to the motion of the first star is deduced from measures referred to corresponding lines in the spectrum of the second. The stars selected for purposes of comparison would naturally be bright stars with well-defined lines, and their motions could therefore be accurately determined by the usual methods. Only a comparatively small number of such standard stars would be required.

For slit spectroscopes it would probably be found that Professor Orbinsky's method is inferior to the usual one, although Professor Vogel finds that it can be applied to some of the photographs taken with the Potsdam spectograph. It not only depends upon a differential effect, and thus reduces the amount of the available displacement, but it requires the measurement of lines which are widely separated, and therefore badly defined in consequence of their great distance from the axis of the camera objective. Even if this lens were constructed with a view to giving a large field the definition would be inferior to that in the center of the field of an objective of the usual construction.

The latter objection does not apply, however, to the case of a telescope with object-glass prism, where a great linear extent of spectrum is obtained with small angular field. It is for instruments of this class that the method is intended, and it seems to promise well. Possibly the range of spectrum could be advantageously increased by the use of orthochromatic plates, which, largely on account of the compression in the lower part of the prismatic spectrum, have an actinic value in the region of $\lambda 550$ not greatly inferior to that near H γ . It is true that few spectra have strong lines in this region. Various advantages and disadvantages attending the use of such plates will readily occur to the observer acquainted with their peculiarities, and actual trial would probably be necessary to determine on which side the balance lies.

J. E. K.

AMERICAN ASSOCIATION FOR THE ADVANCEMENT OF SCIENCE.

SECTION OF ZOÖLOGY.

By reason of the absence of both the Vice-President and the Secretary-elect, the work of the section was somewhat delayed and embarrassed. Mr. L. O. Howard, of Washington, D. C., was nominated by the Council for Vice-President and was duly elected by the Association. Following the work of the general session, Section F. proceeded to complete its organization. Chas. W. Hargitt, of Syracuse, N. Y., was elected Secretary. Chas. S. Minot, of Boston, Mass., was elected Councillor, and George Dimmock was elected as a member of the nominating committee.

The following papers were read on Friday: *The Evolution of the Insect Mouth-parts.* By PROF. JOHN B. SMITH, Rutgers College.

Beginning with the typical mandibulate mouth the author undertook to show the the gradual modification of these parts in the structure of the mouths of all insects,

and further to show that there is no well-defined basis for the distinction of insects into mandibulate and haustelate groups. The paper was a very elaborate discussion of the subject and was listened to with the closest attention. It was illustrated by a series of lantern transparencies prepared by the author or under his direction.

Following this a paper was read by Mr. C. L. Marlatt, of Washington, D. C., on the Mouth-parts of Insects with Special Reference to the Diptera and Hemiptera.

In this paper the author sought to maintain the usually accepted view. It was illustrated by a series of charts and drawings and was a valuable contribution to the subject. Following this there was an animated discussion in which several entomologists participated.

The next paper on the program was by Prof. Chas. S. Minot on the 'Olfactory Lobes.' The paper was a noteworthy contribution to the subject.

Another important contribution to morphology was a paper on the 'Visceral Anatomy of the Lacertilea,' by Prof. E. D. Cope.

On Monday morning occurred the joint session of sections F. and G., at which the following papers were presented:

The Distinction Between Animals and Plants.

By PROF. J. C. ARTHUR.

Variation After Birth. By PROF. L. H. BAILEY. Read by title.

Rejuvenation and Heredity. By PROF. CHAS. S. MINOT.

This paper was a noteworthy contribution to the subject of heredity, and was distinguished by its very forcible antagonism of the views of Weismann and his school.

The following papers were presented at subsequent sessions:

Semiulus as an Ordinal Type. By O. F. COOK.

From abundant material collected by Mr. Cook in Siberia, a more extended examination has been made possible and

characters discovered which he claims justify the recognition of *Stemiulus* as an Ordinal Type.

Characters which are Useful in Describing Larvæ of Spingidae. By GEO. DIMMOCK.

In this paper the author emphasizes the importance of measuring and describing the head, noting the granulations and rugosities of the surface of the Larvæ, and the structure and coloration of the stigmata.

The Affinities of the Pythonomorph Reptiles.

By E. D. COPE.

This paper was discussed in Prof. Cope's usually lucid style, and was illustrated by blackboard sketches.

Temperature Variations of Cattle Observed During Extended Periods of Time, with Reference to the Tuberculosis Test. By JULIUS NELSON.

In this paper the author discussed an extended series of experiments made upon a herd of twenty-eight cattle upon the farm of the New Jersey Agricultural Experiment Station. A graphic representation of the experiments was made by means of carefully executed charts. Very important results were indicated which give promise of great value.

*On the Girdling of Elm Twigs by the Larvæ of *Orgyia leucostigma*, and its results.* By J. A. LINTNER.

Notes upon the Eupaguride. By CHAS. W. HARGITT.

This paper reviews characteristic morphological and physiological traits of the family and discusses their bearing on the subject of heredity.

On a Revision of the North American Craspedosomatide. By O. F. COOK.

*A New Character in the Colobognatha, with Drawings of *Siphonotus*.* By O. F. COOK.

A New Wheel for Color Mixing in Tests for Color Vision. By J. H. PILLSBURY.

Some Further Results of Investigation of Areas of Color Vision in the Human Retina. By J. H. PILLSBURY.

*A Study of *Panorpa* and *Bittacus*.* By E. P. FELT.

The following resolutions relative to the proposed International Bibliographical Bureau were adopted:

WHEREAS, The date of publication is a question of fact to be determined by investigation and not by arbitrary ruling, and

WHEREAS, In the world at large the date of publications of books is the date at which they are printed, and

WHEREAS, The adoption of any other date would have no practical effect for this reason, and for the following reasons, viz.:

First, The majority of publications are not distributed but sold;

Second, The distribution when it occurs may be rendered ineffective by accidents such as fires, loss by mail, etc.;

Third, Distribution by individuals may be delayed or prevented by absence from home, sickness or death;

Fourth, Distribution by governments is often delayed for routine reasons;

Fifth, The actual date of mailing will often be impossible to ascertain with certainty owing to lack of record or irregularity in the period of transmission, and

WHEREAS, The determination of the date of printing will be generally found in the records of the printing office and can be established by the testimony of several disinterested persons, while the time of mailing will be known generally by but one person, therefore

Be it Resolved: First, that the Zoölogical Section of the American Association for the Advancement of Science recommends that the date of the completion of printing of a single issue be regarded as the date of publication; and

Second, that the Section recommends that such date be printed on the last signature of all publications, whether books, periodicals or separates.

Resolved further: 1, That the Section of

Zoölogy is impressed with the desirability of introducing the custom of placing all publications on record at some central agency together with the date of publication;

2, That a committee be appointed to obtain the approval of these resolutions by publishing societies at home and abroad;

3, That a copy of these resolutions be transmitted to the British Association for the Advancement of Science, the Zoölogical Society of London, the Australasian Association for the Advancement of Science, the Association Francaise, the Soc. Zoöl. de France, der Versammlung der Naturforscher und Aerzte, and the International Congress of Zoölogists.

The following committee was appointed: S. A. Forbes, Champaign, Ill.; E. A. Birge, Madison, Wis.; W. A. Locy, Lake Forest, Ill.; Geo. Dimmock, Canoble Lake, N. H.

Following were elected officers of the Section for coming year: Vice-President, Theodore Gill, Washington, D. C.; Secretary, D. S. Kellicott, Columbus, Ohio.

CHARLES W. HARGITT.

SYRACUSE, N. Y.

THE INDEXING OF CHEMICAL LITERATURE.

THE committee on indexing chemical literature, consisting of H. Carrington Bolton, chairman, F. W. Clarke, Albert R. Leeds, Alexis A. Julien, John W. Langley, Albert B. Prescott, Alfred Tuckerman, presented to the Chemical Section of the A. A. A. S. its thirteenth annual report, which is as follows:

During the twelve months which have elapsed since the last report the following bibliographies have been printed:

1. Indexes to the Literature of Cerium and Lanthanum. By W. H. Magee. Smithsonian Miscellaneous Collections, No. 971. Washington, 1895. 43 pp. Svo.

2. Index to the Literature of Didymium, 1842-1893. By A. C. Langmuir. Smith-

sonian Miscellaneous Collection, No. 972. Washington, 1895. 20 pp. Svo.

These bibliographies of three associated metals fill an important gap in chemical literature. That by Dr. Langmuir is reprinted from the School of Mines Quarterly (Vol. XV.), at the request of your Committee. Both indexes are arranged chronologically and provided with author-indexes.

3. Bibliography of Aceto Acetic Ester. By Paul H. Seymour. Smithsonian Miscellaneous Collections, No. 970. Washington, 1894. 148 pp. Svo.

This bibliography was compiled by the author under the direction of Prof. Albert B. Prescott, and by him submitted to the Committee who recommended its publication August 22, 1892. It consists of a series of carefully prepared, critical abstracts of original papers arranged chronologically with author- and subject-indexes.

After issuing the twelfth annual report the attention of the Committee was directed to two contributions to the bibliography of chemical and pharmaceutical periodicals by Dr. Friedrich Hoffmann, editor of *Pharmaceutische Rundschau*, viz.:

4. Die Deutsch-sprachlichen pharmaceutischen Zeitschriften. *Pharm. Rundschau*, New York, Vol. XII., pp. 7-10 (Jan., 1894) and p. 28 (Feb., '94).

5. English-sprachliche pharmaceutische, chemische und botanische Zeitschriften Nord-Amerika's. *Pharm. Rundschau*, New York, Vol. XII., pp. 131-136 (June, 1894).

Several chemists have made reports of progress.

Prof. Henry Trimble, of Philadelphia, states he continues to collect references to the literature of the Tannins with the expectation of further publication at no very distant date.

Prof. Arthur M. Comey reports that his Dictionary of Solubilities, Vol. I., is nearly all in type, and should appear early in the autumn.

Dr. Alfred Tuckerman expects to complete the MS. of his Index to the Mineral Waters of all Nations in a few months.

Prof. F. W. Clarke is making progress with a new edition of the Recalculation of the Atomic Weights.

Dr. H. Carrington Bolton reports having done much work on the Supplement to his Bibliography of Chemistry, the MS. now comprising about 6500 titles.

Mr. C. LeRoy Parker, of the Columbian University, Washington, has undertaken an Index to the Literature of Attempts to Decompose Nitrogen.

Mr. George Estes Barton, of the same institution, is at work on a Bibliography of Glycerol; and Mr. George Baden Pfeiffer, also of the Columbian University, is engaged on a Bibliography of Picric Acid and the Nitrophenols.

At the request of the Smithsonian Institution, Dr. H. Carrington Bolton has undertaken to edit a new edition of his 'Catalogue of Scientific and Technical Periodicals, 1665-1882,' published in 1885 in the Smithsonian Miscellaneous Collections. The new edition will bring down to date the old periodicals and include new ones established since 1882. The work is well under way.

Mr. W. D. Bigelow, of the Chemical Division of the U. S. Department of Agriculture, has completed the MS. of an Index to Methods for the Detection and Estimation of Fusel Oil in Distilled Liquors. The channel of publication has not been determined.

In a communication to the chairman, Professor W. Percy Wilkinson, of Melbourne, states he is engaged on an Oenological Bibliography, to include works relating to the vine, viticulture, wine-making, vine-diseases and wine-analysis, published in Germany, France, England, America, Italy, Portugal and Spain. He expects the bibliography to number 2000 titles and will give

full details as to date, size, editions, etc. It is to be published by the Royal Society of Victoria.

Monsieur G. Fr. Jacques Boyer, editor of the *Revue Scientifique*, Paris, announces the preparation of a Bibliography of Physical and Chemical Science; information as to its scope and period is lacking.

Those interested in the chemical applications of electricity should note the following:

'Elektrotechnische Bibliographie; monatliche Rundschau über * * * der Elektrotechnik. Von Georg Maas,' Leipzig, 1893.

Also: 'Leiner's Elektrotechnischer Katalog * * * von 1884 bis 1893.' Leipzig, 1893. Svo.

The following special bibliography has recently appeared in France: 'Bibliographie de la technologie chimique des fibres textiles. Propriétés, blanchiment, teinture, matières colorantes, impression, apprêts. Par J. Garçon. Paris, 1893. Svo.' This work has been honored with a prize by the 'Société industrielle de Mulhouse.'

Although not pertaining to chemistry, we may briefly note the appearance of another special bibliography; 'Bibliographie der psycho-physiologischen Litteratur des Jahres, 1893. Hamburg, 1894. Svo.' Published in the *Zeitschrift für die Psychologie und Physiologie der Sinnesorganen*.

Attempts to establish a comprehensive Index to Chemical Literature in the form of a periodical are not altogether successful, lacking the important element of permanence. The 'Index' announced by Dr. Bechhold, of Frankfort-on-Main, noticed in our Twelfth Report, has not made its appearance; the 'Biblioteca Polytecnica' by Szczepanski ceased at the close of one year; the 'Universal Index' by Wien and Brockhaus reached only nineteen numbers. Dr. J. Ephraim advertises the following: 'Index der gesammten chemischen Litteratur (Wissenschaft und Technologie), Berlin,' but no number has yet appeared.

ANTARCTIC EXPLORATION.

MR. C. E. BORCHGREVINK contributes to the *London Times* an article on 'Antarctic Exploration,' in which he deduces reasons, both commercial and scientific, in favor of undertaking an expedition toward the South Pole in the near future. The recent Antarctic expedition was a commercial venture, and was equipped with the object of capturing the 'black whale,' valuable for its whale bone. The failure to accomplish this object is attributed by Mr. Borchgrevink to the fact that the expedition did not penetrate far enough into the large open bay in the vicinity of the volcanic peaks, Erebus and Terror. This bay and South Victoria Land were discovered by Sir James Clark Ross in 1841, whose predictions that large numbers of the black whale would be found in the southern latitudes Mr. Borchgrevink believes will be verified in the future. The blue whale is present in large numbers, but in the recent expedition (the first since 1841) these could not be captured owing to the lack of proper appliances. There is also a probability of finding many seals. The guano beds discovered by the 'Antarctic' are reported to be well worth the attention of business men. From the analysis of specimens of rock brought back from the mainland there is a possibility, or even a probability, of the presence of valuable minerals. The discovery of vegetation on the mainland also materially increases the possibilities. Mr. Borchgrevink considers it undesirable, while practically little is known of the the many hundreds of miles further north, to attempt at present to reach the pole, but urges that if this can eventually be reached the value of observations made at the south magnetic pole would be of very great scientific value.

Mr. Borchgrevink then describes the plans proposed for the expedition which he hopes will be undertaken next season. It

has been suggested that the members of the expedition, with appliances and food, should be taken to Cape Adare in a whaling vessel and left there until the ice breaks up in the following summer; that the whaler should then take in cargo, sail for Australia and pick up the exploring party (which would go into winter quarters on the peninsula at Cape Adare) on the return voyage. Mr. Borchgrevink, however, urges that a small vessel (say of 200 tons), to fall back upon in case of need, would greatly add to the safety of the party. A small light vessel would be able to encounter dangers which would be insuperable for a bulkier craft. Mr. Borchgrevink considers the number of men sailing with the expedition should not exceed twelve and that these should be chiefly composed of men of culture. Besides the ordinary outfit on board, which should be of the best, it would be necessary to include two good whaling guns with harpoons and other tackle, Norwegian ski and Canadian snowshoes with necessary footgear. The expedition should also have a sufficient number of sledges, and to drag these a large number of Eskimo dogs would have to be procured. Fuel for 18 months would form a very important item.

Mr. Borchgrevink also recommends two or three semi-globular shaped huts, composed of hard wood, so built as to withstand the pressure of the snow and the force of the wind, and covered with some material capable of resisting a possible rain of stones from the adjoining volcanic craters. A captive balloon with the necessary appliances on the vessel would be extremely valuable, both for the purpose of ascertaining the exact location of open water within the pack, and also to enable a closer view of the magnificent aerial phenomena appearing in these latitudes. It would be desirable also to include letter-carrying balloons in the outfit.

CURRENT PROBLEMS IN PLANT MORPHOLOGY (II.).

THE INFLUENCE OF SPRAY AND RAIN ON THE FORMS OF LEAVES.

THE interesting work of Stahl*—based upon observations made at the Buitenzorg gardens, and thus indicating tropical conditions and recording tropical results—served to direct attention towards those adaptive form-modifications which leaves take when subjected to excessive rainfall. That the points and serrations of the leaves were in such cases usually prolonged and slender; that the leaves frequently adopted a vertically suspended position; that the nerves in many cases were sunken in gullies, thus making channels from which the superfluous water easily escaped; that the arrangement of hairs on leaves and stems contributed to the ready dispersion of water, were among the facts made clear in this contribution. Previous students, as, for example, Lundström† and Wille,‡ had already brought out some of these; but Stahl's work is noteworthy from its novel points of view as well as for its solid additions to the knowledge of the subject. Of particular interest is his summing up of the ecologic importance of rain specializations in tropical leaves. That it is necessary to disburden the leaves of their weight of moisture; that this superfluous water must be conducted to the roots and not intercepted by the crown; that the upper sides of the leaves must be freed from attached epiphytic algæ, fungi and lichens; that the transpiration stream, passing with difficulty from a leaf the surface of which is wet, must be promoted by the rapid drying off of the surface, are some of the rea-

sons brought forward to account for the morphological peculiarities of the rain leaves.

The most peculiar single form-character of the rain leaf is the elongated point or 'Träufelspitze,' and this has been shown to be characteristic not only of tropical plants subjected to a rainy season, but of strand plants subjected to the ocean spray, of high mountain and plateau plants subjected to heavy dews and of temperate zone plants where the rainfall is excessive.

Jungner,* whose earlier researches have contributed to the subject,† brings out a valuable paper in which considerable direct experimental work is recorded and several new observations are described. The most novel part of the work is the discussion of the influence of cataract spray upon the plants growing in the gorge beneath or beside the waterfall. 'Träufelspitzen' are shown to characterize plants in such locations, and several figures showing the difference between normal habitat and spray habitat leaf forms are given. In such an habitat, too, the customary hairiness of the leaf is reduced, hairs having a tendency to retain the water too long, and peculiar groupings of the leaves on the stem, significant as arrangements for rapid draining off of water, were observed. The glazing by wax of the upper surface of the leaf in some cases served to reduce its 'wetableness.'

The most valuable part of the work, however, is the experimental portion in which it is shown how form-modifications may be produced in the greenhouse by subjecting leaves to regular dropping of water or to spray. The characteristic rain forms and spray forms were thus developed in a

(*) Regenfall and Blattgestalt. Leiden, 1893.

† Die Anpassungen der Pflanzen an Regen und Thau, Upsala, 1884.

‡ Kritische Studien über die Anpassungen der Pflanzen an Regen und Thau. Cohn's Beitr. Biol. Pflanz. 4: hft. 3.

* Wie wirkt träufelndes und fließendes Wasser auf die Gestaltung des Blattes? Bibliotheca Botan. 32. Stuttgart. 1895.

† Om regnblad, dagblad och snöblad. Bot. Notiser No. 3, 1893, No. 3, 1894, and Klima und Blatt in der Regio alpina. Flora. 1894.

number of plants. Jungner properly distinguishes between ontogenetic rain leaves and phylogenetic. It is clear, however, that it is not necessary in every case to attribute the special form to any deeper effective cause than the direct influence of the environment. This whole line of experiments, recorded by Jungner, is a notable contribution to the modern literature of adaptation phenomena—a literature which on the whole is as richly and as sanely developed in the field of plant morphology as anywhere.

CONWAY MACMILLAN.

UNIVERSITY OF WISCONSIN

SCIENTIFIC NOTES AND NEWS.

THE next International Congress of Zoologists will be held in England in 1898 under the presidency of Sir William H. Flower. The International Congress of Physiologists will also hold its next meeting in England, having accepted the invitation to Cambridge given by Prof. Michael Foster.

FOUR American men of science were elected corresponding members at the recent meeting of the British Association: Professor John S. Billings, University of Pennsylvania; Professor D. H. Campbell, University of California; Professor H. F. Osborn, Columbia College, and General F. A. Walker, Boston.

AT the suggestion of Dr. H. Carrington Bolton the Smithsonian Institution is now corresponding with American universities for the purpose of making a collection of all printed Dissertations published by candidates for higher degrees.

M. PIERRE FAUVEL reported to the Paris Academy on September 9th that the severe cold of last winter was very destructive to the marine fauna of France, the mortality extending even to a depth at which the temperature could not have had any direct effect. Nearly the entire contents of the

dragnets, both of the marine laboratory and of the fishermen, consisted of animals dead and decomposed. Thus eighty per cent. of the scallops (*Peeten maximus*) were decomposed and the others were in such condition that they could not be sold. In the spring rare species and some new to the fauna of the coast were present in great abundance.

CAPTAIN LENOX-CONYNGHAM is in charge of a mission sent out by the British government for the purpose of determining the difference of longitude between Greenwich and Madras. After having finished operations at Odessa the mission will proceed to Batum and then on to Baku, Resht and Teheran. Facilities have been promised to this mission by the Russian and Persian governments.

SINCE the report on indexing chemical (see p. 478) was presented before the A. A. A. S., Mr. W. D. Bigelow's 'Index to Methods for the Detection and Estimation of Fusel Oil in Distilled Liquors' has been accepted for publication by the Journal of the American Chemical Society.

Prometheus, the German scientific journal, in Nos. 300-302, publishes an article, '*Der thierische Körper als Kraftmaschinen*,' translated from SCIENCE by Dr. Reuleaux, the Director of the Polytechnicum at Charlottenburg and author of '*Briefe aus Philadelphia*'; the latter famous for their frankness in revealing the defects of German manufactures and especially for their prompt effect in stimulating improvement. Professor Reuleaux prefaces Dr. Thurston's paper by an appreciative introduction, and supplements it by an interesting statement of his own ideas on the subject.

THE next meeting of the German Association of Naturalists and Physicians will be held at Frankfurt.

A TELEGRAM to the London *Times* states that Professor Anderson Stuart, of the Uni-

versity of Sydney, has invented an artificial larynx for a man who had lost his voice. The invention is a singular success. The changing of certain reeds contained in the instrument makes the voice soprano, tenor, contralto or bass, at will.

DR. HJALMAR HJORTH BOYESON, professor of Germanic languages and literatures in Columbia College, died on October 4th, at the age of 47 years. Professor Louis Polleus, professor of French in Dartmouth College, died on September 22d, at the age of 56 years.

PROFESSOR ELI WHITNEY BLAKE, who until last June filled the position of Hazard professor of physics in Brown University, died on October 1st, at the age of 59 years. The following particulars concerning his life are taken from the Boston *Transcript*. Professor Blake was born in New Haven, his father being the well-known inventor of the same name. He was graduated at Yale University in 1857, studied chemistry and physics in the universities of Heidelberg, Marburg and Berlin, and returning to this country was named professor of chemistry and physics in the University of Vermont and the State Agricultural College. He was then appointed professor of physics and mechanic arts at Cornell University; later he became acting professor of physics at Columbia College, and from 1870 until last June filled the chair of physics at Brown University.

The following lines (we do not know at whose instance) have been engraved upon Huxley's tombstone:

"And if there be no meeting past the grave,
If all is darkness, silence, yet 'tis rest.
Be not afraid, ye waiting hearts that weep!
For God 'still giveth his beloved sleep.'
And if an endless sleep he wills, so best!"

DR. ELLIOT FOLGER ROGERS, instructor in chemistry at Harvard University, died on October 3d.

DR. ERNEST BAUMANN, the African explorer, died at Cologne on September 4th, at the age of 24 years.

MR. JAMES CARTER, paleontologist at Cambridge University, died recently at the age of 81 years.

DR. HEINRICH ADOLF BARDELEBEN, professor in the medical faculty of the University of Berlin, died recently at the age of 76. Dr. Bardeleben was the author of a number of important works, the principal of which is a text-book on Surgery and Surgical Operations, in four volumes, which has passed through a number of editions.

GENERAL O. M. POE, U. S. Engineer, died on October 1st.

THE German correspondent of the N. Y. *Evening Post* writes that Professor H. Kayser, Director of the Physical Institute in Bonn, has demonstrated that helium (as well as argon) exists in a free condition in nature. The waters of Wildbad, in the Black Forest, for instance, contain in the bubbles of gas rising continually to the surface (about 96 per cent. nitrogen), both those elements which on bursting escape into the surrounding atmosphere. Even in the natural air in Bonn, Professor Kayser found helium in a free state, but, as the spectroscope showed, in infinitesimal quantities.

HOUGHTON, MIFFLIN & Co. announce the publication in book form of Mr. Percival Lowell's articles on 'The Planet Mars,' reprinted from the *Atlantic Monthly*.

PROFESSOR VICTOR RYDBERG, the Swedish writer and archæologist, died on September 22d, at Stockholm, at the age of 67 years.

A REPRESENTATIVE of the Jackson-Darrowsworth expedition has received a cablegram from Vardi beyond the North Cape with the news that the 'Windward,' after an exceptionally severe winter in the Arctic seas, had at last regained inhabited regions. Mr. Jackson and his party, in-

cluding equipment, dogs and provisions, had been safely landed on Franz Joseph Land, on September 7, 1895. Two days later ice closed round the 'Windward' and she was frozen in for the winter. The crew remained on the ship, but joined in the efforts of the explorers (who took up their abode in treble-walled Russian log houses which they had brought with them from England) in procuring fresh meat for food. When the ship left the explorers they were starting on their journey northward with good hopes of being able to explore successfully the unknown polar regions.

THE Dominion Medical Association held its twenty-eighth annual convention under the presidency of Dr. W. Bayard, on August 28th.

THE Rev. Dr. Williamson, professor of astronomy in Queens University, died on September 27th, in Kingston, Ontario, at the age of 87 years.

MR. EPHRAIM W. BULL, the well-known agriculturalist, died on September 26th, at the age of 89.

EXPERIMENTS in marching have been recently undertaken by students of medicine in the Friedrich Wilhelm Institute in Berlin, at the request of the German War Office. The results as reported in *The British Medical Journal* are as follows: The marches performed varied from 22 to 33 miles in length and were undertaken in all weather. The weights carried were from 48 to 68 pounds. A march of 25 miles undertaken at a temperature of 60° F. had no ill effect even if continued for some days consecutively, but under the same conditions at a temperature of 70° F. it necessitated a rest of at least ten hours in the twenty-four. A load of 68 pounds carried 25 miles produced grave physiological disturbance and necessitated a complete rest on the following day, but if the distance were reduced to fifteen miles 60 pounds

could be carried day after day in ordinary summer weather without injurious effects.

A LETTER written to the *American Machinist* states that the new rule allowing inventors six months instead of two years' time in which to prosecute an application for a primary examination went into effect April 15, 1895. Pending cases will be affected as though the last office decision were upon that date; therefore, all applications which were pending before that date should be amended or argued before October 15, 1895.

UNIVERSITY AND EDUCATIONAL NEWS.

THE fifth annual Report of the U. S. Commissioner of Education, Dr. William T. Harris, for the year ending November 30th, 1893, states that the entire number of pupils in the schools and colleges of the United States was 15,083,630, 22.5 % of the population, an increase of 370,697 over the previous year. The number of pupils enrolled in the public schools was 13,510,719, an increase of 1.92 %. The average attendance showed an increase of 3.45 %. The attendance for each child was only during about one-fifth of the year. 122,056 men and 260,954 women were employed in teaching. The number of schoolhouses was 235,426, valued at \$398,435,039. It is stated that the value of school property and the common school expenditure have more than doubled during the preceding twenty years. The report contains statistics of public high schools, professional educational institutions and normal schools, and includes a review of systems of education in foreign countries; reports of the International Congress of Education at the World's Fair; criticisms on American education by representatives of the German government at Chicago; a report on American technological schools by Professor Riedler, of the Royal Polytechnicum at Charlottenburg, near Berlin, and

the report of the committee of ten appointed by the National Educational Association upon the courses of instruction in secondary schools.

DR. EDMUND J. JAMES, professor of public finance and administration in the Wharton School of Finance and Economy, and professor of political science in the graduate department of the University of Pennsylvania, has accepted the professorship of public administration at the University of Chicago.

RICHARD E. DODGE, of the department of geography in Harvard University, has been appointed instructor in geography and geology in the Teachers' College, New York.

THE University of Pennsylvania expects an increase in the number of students in almost every department. The Freshman Class in the medical school numbers about 250, and the upper classes include 50 students from other institutions.

DR. ARTHUR D. FRIZELL has been appointed associate professor of mathematics in the University of the City of New York.

CORRESPONDENCE.

THE ABSORPTION OF TERRESTRIAL RADIATION BY THE ATMOSPHERE.

IN the issue of SCIENCE for August 16th Professor Hallock's account of Langley's bolometric studies contains the following statement: "Our atmosphere acts like a valve, transmitting in almost undiminished strength the short quick waves of energy radiated to us from the sun, but refusing absolutely to return the long slow waves in which the earth tries to radiate the energy back into space. Without this atmosphere we should all have been frozen long ago" (p. 178).

This leads to an interpretation of Langley's results so different from that which I have gathered from his writings that a brief comment on the subject seems desirable. It seems to me that Langley has shown that the solar rays find

the atmospheric valve badly clogged when they attempt to pass inward through it, and that the terrestrial rays find the valve very leaky when it tries to prevent their passage outward.

In the first place, regarding the entrance of solar rays, Langley found from his observations at Allegheny and Mt. Whitney that about half their energy is lost in passing down through clear air. He drew a curve to represent the distribution of energy in the spectrum of the high sun at Allegheny; the area included between the curve and its horizontal base line corresponding to 1.7 on a scale of calories. Another curve was constructed on the same base, but with ordinates representing the inferred distribution of energy in the solar spectrum outside of the atmosphere; the area here included corresponding to 3.5 calories ('Researches on Solar Heat,' Prof. Papers, U. S. Signal Service, XV., p. 144 and pl. XV.). Later statements increase the average percentage of transmission of the solar beam to 70% ('The Temperature of the Moon,' Mem. Nat. Acad. Sciences, 1888, IV., 89); but a valve that could, when open, allow only 70% of a current to pass through it would be regarded as a very imperfect mechanism.

In the second place, the action of the atmosphere on rays emitted from the earth is inferred chiefly from its action on rays emitted by the moon and by experimental radiators. The moon's spectrum is shown to consist of two parts; one part being simply reflected sunlight with its maximum energy in rays of 'luminous' wave-lengths; the other part being true lunar rays, emitted by true lunar radiant action, with their upper and lower limits at wave-lengths of one and perhaps fifty μ , and their maximum energy in wave-lengths of seven μ . These latter are in a spectral region of which no one had any knowledge whatever before Langley's studies about 1886. The solar rays, infra-reds as well as luminous and ultra-violet rays, are transmitted by glass, but the true lunar rays are entirely cut off by glass and must be studied with rock-salt prisms. The ratio of the energy of the solar rays reflected by the moon to that of the true lunar rays is as one to seven (Mem. N. A. S., IV., 197; or Amer. Journ. Science, Dec., 1889, 435). As is the case with the rays

from other solid radiators, the lunar beam has the greatest quantity of energy in rays of greater wave-length than those of its maximum energy (A. J. S., 435), and this is a matter of great importance in the present connection. The air is practically opaque to the strongest of these rays, of wave-length about seven μ , for it is here that the 'great cold band' of the lunar spectrum occurs; yet in the region of the great body of coarser but weaker lunar rays the percentage of transmission rises to 70 or 80 (Mem. N. A. S., pl. 6 and 7; A. J. S., pl. X. and XI.). The average transmission of the whole lunar beam of emitted rays is estimated at 40% (Mem., 189). A valve with a leakage of 40% should not be spoken of as 'absolutely refusing' to let a current pass; it should hardly be called a valve at all. Assuming that terrestrial and lunar radiations are much alike, Langley's results seem to show that something more than half of the solar beam comes in through clear air, and something less than half of the terrestrial beam goes out. It can be only by the small amount of energy thus saved to our use that the temperature of the earth is maintained.

Regarding the process by which the earth maintains its existing temperature, there is an interesting suggestion by Prof. Arthur Searle, of the Harvard College Observatory, in a brief essay entitled 'Atmospheric Economy of Solar Radiation' (Proc. Amer. Acad. Arts and Sci., XXIV., 1888, 26-29), to which those who are interested in this problem may refer, and from which I quote the following sentence in order to show how others than myself read Langley's conclusions: "The hypothesis which has been current until recently with regard to this protective action of the atmosphere depended upon a supposed effect of selective absorption, which has now been largely, if not entirely, disproved by Langley's experiments" (p. 26).

The following quotations may indicate Langley's position regarding the 'valve' or 'trap' or 'hot-bed' action of the atmosphere: "Allegheny observations * * * show that a considerable part of this radiated [lunar] heat does pass through our atmosphere along with that reflected" (SCIENCE, 1st Ser., Jan. 1, 1886, 8). "Contrary to all previous experience, it [the lunar beam] nevertheless reaches us, thus bringing

evidence of the partial transparency of our terrestrial atmosphere even to such rays as are emitted by the soil of our planet" (Mem. N. A. S., 193). "To see how the question of the lunar heat affects our knowledge on the whole subject of our planet's temperature, we must remember that until a few years past it had been assumed by all writers of repute that the earth's atmosphere acted exactly like the glass cover of a hotbed, and kept the planet warm, in exactly the same way that the hotbed is warmed, by admitting the light-heat of the sun, which was returned by the soil in the invisible radiations of greater wave-length to which the atmosphere was supposed to be impervious, and that thus the heat was stored" (Mem., 110). Although no equally explicit announcement is made of the belief with which Langley would replace this assumption made by 'all writers of repute,' these extracts and quotations give reason to think that Professor Hallock's brief statement is over-strong in using such phrases as 'almost undiminished' and 'refusing absolutely.' The analogy of the valve needs so much qualification that it is not very serviceable in the way of explanation.

In this connection, a few words may be added on the matter of terminology, which I find very embarrassing. We all recognize that the careful definition of scientific terms is an important aid to careful thought, and that the use of a term loosely and vaguely is apt to tangle up the ideas of the hearer or reader, if not of the speaker or writer. The introduction to Maxwell's 'Theory of Heat' offers an excellent illustration of the care with which that masterful physicist used his terms (Appleton's Edition, 1883, p. 8, 9. He afterwards says: "Heat is certainly communicated from one body to another by a process which we call radiation, which takes place in the region between the two bodies. We have no right, however, to speak of this process of radiation as heat. We have defined heat as it exists in hot bodies, and we have seen that all heat is of the same kind. But the radiation between bodies differs from heat * * * in being of many different kinds * * * When we speak of radiant heat we do not mean to imply the existence of a new kind of heat, but to consider radiation in its thermal aspect.")

(p. 15, 16). Yet, even Maxwell speaks of 'heat rays,' almost as if they objectively possessed heat, and, of course, with the implication that 'rays of light' are not 'heat rays.' Can it be urged too strongly that the rays differ objectively only in wave-length and amplitude, and that their relations to heat and light are entirely and absolutely subjective? Yet loose phrasing is continually met with. Langley writes of 'luminous heat' and of 'the radically different character of the heat in these two maxima' (A. J. S., ut supra, 434, 435). Hallock writes: "Then it was that heat was recognized as another manifestation of those periodic disturbances, or waves, in that elastic medium which was then known as the luminiferous ether, and which is now universally known as 'the ether' (SCIENCE, ut supra, 174). Perhaps this refers to the mis-recognition of the early part of this century; perhaps professional physicists get along comfortably enough with 'dark heat rays' and the rest; but to those who have to use physical results in other lines of study, this indefinite phraseology is very troublesome.

W. M. DAVIS.

HARVARD UNIVERSITY, Sept. 30, 1895.

SHELLS AS IMPLEMENTS.

PLEASE call the attention of those who own or have charge of archæological cabinets to an illustration in von den Steinen's 'Unter den Naturvölkern Zentral Brasiliens,' 1894, p. 207, fig. 27. A fresh water mussel shell has a hole through it just as you see in specimens on plate xxvi. of Holmes' paper. 'Art in Shell.' But von den Steinen says that these shells are used as scrapers; the edge on large objects and the hole through the shell is also used by the tribes living on the upper Shingu for smoothing or scraping wood. His next remark about pushing the hole in with an Akuri nut I do not comprehend.

O. T. MASON.

THE INVERTED IMAGE ON THE RETINA.

IN the last number of this journal (p. 438) Professor Brooks writes: "We all believe many things which are inconceivable, such as the truth that the image in our eyes is upside down." But why is this inconceivable? To

those having knowledge of elementary physics it is inconceivable that the image should not be inverted. Perhaps Professor Brooks means that it is incomprehensible that we should see things right side up when the image is upside down. This is sometimes urged, but would seem to be sufficiently answered by a remark once made by Lotze in the presence of the writer: "If any one is troubled by the fact that the image is inverted, let him suppose that the soul stands on its head." It is, indeed, quite as reasonable to suppose that the mind stands on its head as to suppose that it stands on its feet and looks at the image on the retina—which would seem to be the assumption of those who are troubled by the phenomenon.

A similar paradox is the fact that with two images on the retinas we see things singly. This may also be treated without undue seriousness by the question: "If we hear a baby crying with two ears, why do we not think it is twins?"

J. MCK. C.

SCIENTIFIC LITERATURE.

Mental and Physical Fatigue by M. Mosso. Translation by P. Langlois. (Bibliothèque de philosophie contemporaine.) Paris, Félix Alcan. 1894.

The Difference Between the Muscles in Their Normal and Their Abnormal, or Fatigued Condition by M. WEDENSKY. Archives de physiologie; Comptes rendus de l'Académie des Sciences.

It is but recently that problems of this nature have been treated by physiologists.

Kronecker, in his experiments on the detached muscles of the frog, succeeded in obtaining 1,000, even 1,500 contractions, the intensity of which decreased regularly in proportion to the increase of fatigue; thus, for contractions at regular intervals, produced by currents of equal intensity, the curve of fatigue is a straight line. Kronecker also observed the great individual differences existing in animals in their power of resistance to fatigue.

M. Mosso, the author of the present work (unfortunately abridged in the French translation), is an Italian physiologist who has undertaken with an instrument of his own invention,

which he calls an 'ergograph,' to measure the normal variations of muscular force in man. The work contains illustrations of the apparatus in question, as well as the various curves obtained by the experiments. The instrument consists: (1) of a small cushioned platform upon which the forearm rests, fastened down at the wrist in such a manner as to give free play to the fingers, the hand remaining immobile meanwhile; (2) a pulley, consisting of a wheel and cord, one end of which is attached to a weight and the other end to the finger to be experimented upon—usually the middle finger. To this cord, moving in a groove, is fixed a sliding pen, the point of which rests upon the registering cylinder above. At intervals of two seconds, marked by the metronome, the subject is expected to concentrate all his force on the muscles of the middle finger for the purpose of lifting the weight at the other end of the cord. The weight thus lifted was usually 3 kg. The line passing through the maxima of the contractions formed the curve of fatigue.

Experiments of this character are open to theoretical objection. It is evident, from the curves obtained by the registering cylinder, that the digital contractions are in no case instantaneous, and that each portion, or part, of a given contraction differs from the preceding or succeeding one. However, the conditions of M. Mosso's experiments were practically such that the variations of time between the different fractions of contraction were but slight. For all practical purposes, then, the curve thus obtained may be considered a curve of instantaneous effort in equal intervals of time.

Similar experiments, made upon himself by M. Aducco, a fellow-worker of the author, show two curves—one obtained in winter, the other in summer. They are not alike. These curves vary not only for different subjects, but also for the same subject under various conditions dependent upon the state of health or preceding muscular effort.

There is also given a curve of fatigue produced by an interrupted current applied in the same manner to the median nerve. The intensity was not at its maximum, but the author affirms that an increase of intensity aug-

ments but feebly the amplitude of the contractions. The curve thus obtained is essentially the same as that obtained by muscular contractions under the influence of the will, from which he concludes that physical fatigue is a phenomenon depending on the muscles rather than on the excitability of the nervous centers. Nevertheless, if we consider an effort of the muscles excited by the will and an effort of the muscles excited by electricity simultaneously, we find the former much greater than the latter.

It is known that fatigue engenders poisoning, and that the blood of an animal in this abnormal state, injected into another animal, will produce all the phenomena of fatigue. When the leg of a frog that is being operated upon becomes fatigued, the poison may be, so to speak, neutralized, and the contractions may be made to continue by injecting salt water in the artery which carries the blood to the muscles. In case of a total absence of blood, its place may be wholly supplied by salt water. The frog may in this manner be kept alive one or two days and continue to react during the first few hours like a frog in normal condition.

These poisons, under the name of *ptomaines*, are now being studied. But until we obtain the knowledge which will enable us to neutralize them chemically, it is well to know that their elimination may be facilitated by all the various operations calculated to accelerate respiration, massage, etc.

Severe intellectual labor diminishes the pulse, produces a fullness in the head, causes palpitation of the heart, pain in the brain and in the muscles of the eye, sometimes photophobia and often vertigo. Dyspepsia, also, is among its painful consequences. Violent muscular exercise has been prescribed as a remedy for all these ills, but this is shown to be a mistake. The only remedy is rest—a complete cessation of mental labor, the disturbing cause. The fact is that, after a prolonged physical effort, nervous excitement increases in proportion as muscular energy diminishes, and this excitement is apt to extend to other muscles which should not be brought into participation.

Another device of M. Mosso, a modification of the ergograph, which he calls the *ponomètre*, permits him to measure this *travail à vide*, as he

designates the uncontrollable, fruitless, nervous activity superinduced by over-fatigue, and which is so exhaustive to the nervous centers. He shows, furthermore, by his experiments on carrier pigeons, that excessive muscular fatigue produces anæmia of the brain. A slight modification in cerebral circulation is sufficient to impair the intellectual faculties and may even determine a swoon. In experiments made upon a subject named Bertino, the author produced syncope and convulsions by a compression of the carotid arteries—an opening of some half inch in the frontal region of his subject, enabling him to register the pulsations of the brain meanwhile.

Every one has heard of *curare*, first introduced into Europe in 1595. It is a dark-brown, solid substance contained in little earthen pots, as prepared by the Indians of South America, by whom it is used principally to poison their arrowheads for war and the chase. The active principle in curare is its curarine, a ternary substance consisting of azote, hydrogen and carbon. This substance has two remarkable qualities: Contrary to what is usually the case with vegetable poisons, it may be absorbed internally with impunity, and in fairly large doses (by mammals, at least), whereas in the form of hypodermic injections it becomes a violent poison. On the other hand, it does not affect the nervous centers—the mental powers, the sensitive nerves and the muscles, while paralyzing the motor nerve. It doubtless especially affects the terminal plate where the motor nerve unites with the muscle. It kills by arresting the heart's action.

Professor Wedensky, of the St. Petersburg University, has lately reproduced the paralyzing effect of curare by a very different process. With the electric apparatus of Dubois Raymond he excites the motor nerve by frequent and violent currents. Under the influence of this irritating treatment, the muscle, instead of contracting, relaxes almost completely, and its condition becomes analogous to that produced by the mysterious influence of the curare. As the intensity and frequency of these excitations are diminished, the muscle tends to resume its contractile power and to return to its normal state.

These experiments are of the greatest interest. They show the fatal consequences attending frequent and intense nervous effort; they permit us at the same time to calculate the danger of paralysis and to anticipate it. These new processes enable us to distinguish the normal muscle from the enervated muscle—that is to say, the muscle deprived of the influence of the spinal marrow and the nervous fibres—after long and intense irritation, whether caused by over-taxation of the brain or of the muscles.

Professor Wedensky calls attention to the fact that the enervated muscle in presence of the electric battery acts in a much simpler manner than the normal muscle when the excitations traverse the tissues in their entire length. The normal muscle, subjected to currents of gradually increasing intensity, will contract but slightly at first, then more, and then less again; whereas, the enervated muscle will increase its contractions with the intensified current, relaxing as the intensity diminishes. Furthermore, if a second current be added to the first, it will have no effect on the normal muscle, while for the enervated muscle the second current reinforces the first.

A stethoscopic auscultation of the muscles after frequent irritations will, in case of enervation, reveal sounds whose rhythm corresponds almost exactly with that of the induced current; the vibrations of the normal muscle, on the contrary, will be found to maintain their own independent rhythm.

Finally, it must be remarked that the normal muscle is much more excitable under the influence of an ascending current than a descending one. The contrary is the case for the enervated muscle, and even for the muscle that is simply fatigued.

From these facts results an important practical application, an exact method for the examination of cases of fatigue and paralysis. For instance, let the subject under examination clasp in his right hand the negative pole while the positive pole rests on his right foot; then ascertain the degree of intensity required to produce the least possible contraction of the muscles traversed by the current; whereupon reverse the order of the electrodes, placing the positive above and the negative below, thus subjecting

the same muscle to a descending current of the same character, the intensity of which, like the first, shall be the least perceptible. If the intensity of this latter current proves to be inferior to that of the former, the inference is that the muscular mass experimented upon is enervated. The greater the difference between the two degrees of intensity, the more serious will be the state of muscular enervation.

The great question for physiologists to answer now is: By what means are we to realize the full measure of muscular capacity in man and beast? The problem is in their hands, and the merit of M. Mosso and Wedensky is that they have succeeded in studying experimentally some of the questions so deeply interesting to those engaged in this work.

CHARLES HENRY.

PARIS.

List of Mammals collected in the Black Hills Region of South Dakota and in Western Kansas by W. W. Granger, with field notes by the collector. By J. A. ALLEN. Bull. American Museum Nat. Hist., Vol. VII., pp. 259-274, Aug. 21, 1895.

The Black Hills region is one of more than ordinary interest to the naturalist, and it has received its full share of attention. Perhaps no area of equal size in the United States has been more closely studied by geologists and paleontologists, and it has been visited more than once by zoölogists and botanists.

The special interest attaching to the Black Hills, from the standpoint of the living fauna and flora, centers in the fact that it is the easternmost of the outlying boreal islands belonging in a general way to the Rocky Mountain region. This was clearly indicated by the first report on its mammals and birds, published by Geo. Bird Grinnell in 1875. Since then it has been visited three times by the experienced mammal collector, Mr. Vernon Bailey, but the results of his labors have not yet been published. The present paper by Dr. Allen, based on a collection made by Walter W. Granger in 1894, is therefore the first enumeration of the mammals of the region since modern methods of trapping came into vogue.

Three life zones—*Boreal*, *Transition* and *Upper Sonoran*—are embraced in the area covered by the report, though this important fact is not recognized by the author. The higher parts of the Black Hills are *Boreal*; the lower slopes, embracing most of the pine forest, are *Transition*; the adjacent 'bad lands' south of the Cheyenne River are *Upper Sonoran*. The Boreal element is completely isolated, being separated by a wide interval from the nearest land of sufficient elevation to support a similar fauna and flora. The following Boreal species occur in the Black Hills: *Microtus longicaudus*, *Peromyscus g. brevicaudus*, *Peromyscus l. arcticus*, *Neotoma cinerea* [= '*grangeri*'], *Sciurus h. dakotensis*, *Arctomys dakota*, *Sorex personatus* [recorded as *forsteri*], *Tamias l-vit. borealis* and *Zapus*. The Transition element covers the greater part of the hills, and stretches uninterruptedly northward east of the Little Missouri River. It is inhabited by *Lepus campestris*, *Onychomys leucogaster*, *Neotoma rupicola*, *Peromyscus nebrascensis* and *Microtus austerus haydeni*. The Upper Sonoran element finds its northern limit near the Cheyenne River, on the east side of the Hills, but pushes farther north on the west side. It introduces several species (*Geomys lutescens*, *Perognathus paradoxus*, *Perodipus richardsoni*, *Corynorhinus 'townsendi*' and a few others) not occurring elsewhere in the region.

Dr. Allen describes a new cottontail (*Lepus sylvaticus grangeri*) from the higher parts of the Black Hills, and in a previous paper named as new several other mammals collected by Mr. Granger. It is stated that the Gray Pocket Gopher (*Thomomys talpoides*) "is found not only in the prairie country at the base of the Black Hills, but in the small parks in the Black Hills, at an altitude of 5500 ft." Specimens collected in the higher parts of the Black Hills by Mr. Bailey are not the same as those from the surrounding low country.

In all, 53 species are enumerated, with more or less full annotations. The specific name of the Black-tail deer is carried back from *macrotis* Say (1823) to *hemionus* Rafinesque (1817).

The list as a whole is a welcome addition to our local knowledge of the mammals of a small but interesting area.

C. H. M.

SCIENTIFIC JOURNALS.

JOURNAL OF GEOLOGY, AUGUST-SEPTEMBER.

James Dwight Dana and His Work as a Geologist: By H. S. WILLIAMS. Prof. Dana's contributions to the geology of this country are so many and so varied, they are such a fundamental part of our knowledge, that so long as the science endures he cannot be forgotten. Prof. Williams has succeeded in bringing together the salient features of his work in a very satisfactory manner.

Glacial and Interglacial Deposits near Toronto: By A. P. COLEMAN. The question whether there was one or two or more glacial epochs has been so long and earnestly discussed that we hail with pleasure any decisive and positive contributions to the subject. Such is this article by Mr. Coleman. He finds in the cliffs near Toronto three beds of till separated by stratified material. Between the lower and middle till the stratified material is 140 feet of laminated clay and sand, while between the middle and upper till there is seventy to one hundred feet of sand and clay. In the first of these a larger collection of fossils has been found than in any like deposit in the world. Among insects five families, fifteen genera and twenty-nine species are represented. These are all extinct forms and may be considered as indigenous to the locality and not decidedly boreal. Of vegetable remains fifteen species were represented. These, according to Dr. Macoun, indicate a climate like that of the northern part of the Gulf of St. Lawrence or southern Labrador. There was no sign of ice action, but rather of quiet water conditions. In the valley of the Don, a few miles away, apparently in the same relations to the till, many unios were found, a few gasteropods and specimens of the wood of Oak, Ash, Elm, Pawpaw and Osage Orange were found. These point to a climate as warm as that of Toronto at present, if not as warm as Ohio. The unios are such as chiefly now belong to the Mississippi basin and not to the St. Lawrence. In addition to the lapse of time indicated by the deposit of these one hundred and forty feet of fine sediments he finds an erosion interval represented by ninety feet deep and one-half mile wide cut in the deposits after

their emergence and before the succeeding beds were formed. Above these beds is thirty feet of till consisting of a blue calcareous clay with striated erratics of limestone and Utica shale, together with Laurentian boulders. Then follows about one hundred feet of stratified sand and gravel, which has no fossils and shows evidence of the not-distant presence of the ice. The upper till is twenty to thirty feet thick and contains striated erratics of limestone, shale and gneiss. Mr. Coleman seems to make a very strong case for one important interglacial epoch and one subordinate interglacial episode.

Origin of Certain Features of Coal Basins: By H. F. BAIN. A description of the coal basins of Iowa as throwing light on coal horizons in general.

Preglacial Gravels on the Quartzite Range Near Baraboo, Wis.: By R. D. SALISBURY. Certain peculiar gravels are found at high levels in Wisconsin and surrounding States which differ from all glacial gravels. The author discusses the significance of these, suggests a correlation and concludes that the area indicated was submerged much later than had been supposed, possibly as late as the Cretaceous or Tertiary.

Glacial Studies in Greenland: By T. C. CHAMBERLIN. This is one of a series of papers founded on the personal observations of the author during the last summer. They embody some rather unique additions to our knowledge of the formation and work of glaciers.

The Upper Paleozoic Rocks of Central Kansas: By C. S. PROSSER. This is a description and correlation of the rocks of Kansas.

Summary of Current Pre-Cambrian North American Literature: By C. R. VAN HISE. Since the introduction of the microscope into geological study a flood of light has been thrown upon this difficult field—the pre-Cambrian rocks. Many investigators are working and there has come to be an extensive literature. Prof. Van Hise brings together this literature and endeavors to interpret it.

THE AMERICAN GEOLOGIST, OCTOBER.

The Synchronism of the Lake Superior Region with other portions of the North American Continent: By N. H. WINCHELL. The author shows that a close similarity exists between the pre-

Silurian strata of the Lake Superior region and eastern New York (including adjacent areas in Canada and New England). This similarity is expressed in the lithological structural and faunal character of the rocks of the two regions. Strata of the Lower, Middle and Upper Cambrian are recognized in both districts. A plea is made for the use of lithological constants in correlating rocks belonging to the earlier epochs of geological history when similar oceanic and physical conditions spread over vast expanses of the earth's surface.

Brachiocrinus and Herpetocrinus: By F. A. BATHER. The generic terms *Brachiocrinus* and *Mylodactylus* were early applied to so-called arm fragments of crinoids. These seem to have been really stem fragments, and as such were later correctly described as *Herpetocrinus*, which term the author thinks wise to retain in place of the others. A revised diagnosis of *H. nodosarius* is presented.

Description of a New Genus and Five New Species of Fossils from the Devonian and Sub-Carboniferous Rocks of Missouri: By R. R. ROWLEY. The new genus is *Aristocrinus*, and the new species belong to the genera *Allagecrinus*, *Granatocrinus*, *Gonialites*; *Pleurotomaria* and *Murchisonia*.

The Elective System as Adopted in the Michigan Mining School: By M. E. WADSWORTH. The Michigan Mining School has recently adopted an elective system which allows more freedom of choice than that in any other mining or technical school. Two studies only—elementary geology and the elementary principles of mining—are required of all students, but there is in some cases a natural sequence of studies, so that students, in order to pursue advanced work in certain lines, must first complete the earlier work in the sequence.

Rock Hill, Long Island, N. Y.: By JOHN BRYSON. An immense boulder on the summit of Rock Hill is described and figured. This boulder is now about 50 by 20 feet, but the author thinks that it was originally, before being quarried for stone, more than 125 by 20 feet. Several other glacial features of the region are discussed.

The Geological Society and American Association Meetings: By WARREN UPHAM. An ex-

tended and complete account of the recent meetings at Springfield, Mass., is given. Abstracts of all the papers (and discussions) read before the Geological Society and before Section E of the A. A. S. are included.

The International Geological Congress.—A Correction: By ALBERT HEIM. Prof. Heim calls attention to some misstatements concerning himself which appeared in the account of the last meeting of the Congress.

NEW BOOKS.

The Manufacture of Explosives. OSCAR GUTTMANN. 2 Volumes. New York, Macmillan & Co. London, Whittaker & Co. 1895. Pp. xiii+348, xii+444. \$9.00.

Solution and Electrolysis. W. C. D. WHETHAM. Cambridge University Press. New York, Macmillan & Co. 1895. Pp. viii+296. \$1.90.

A Laboratory Manual of Organic Chemistry. DR. LASSAR-COHN. Translated by ALEXANDER SMITH. London and New York, Macmillan & Co. Pp. xix+403. \$2.25.

Bulletins of the U. S. Geological Survey, No. 118. Pp. vi+131. *A Geographic Dictionary of New Jersey*. HENRY GANNETT. No. 119. *A Geological Reconnaissance in Northwest Wyoming*. GEORGE HOMANS ELDRIDGE. Pp. vi+72. No. 120. *The Devonian System of Eastern Pennsylvania and New York*. CHARLES S. PROSSER. Pp. vi+81. No. 121. *A Bibliography of North American Paleontology*. CHARLES ROLLIN KEYES. Pp. vi+251. No. 122. *Results of Primary Triangulation*. HENRY GANNETT. Pp. vi+412. Government Printing Office, Washington, D. C. 1894.

Lakes of North America. ISRAEL C. RUSSELL. Boston and London, Ginn & Co. 1895. Pp. x+125. \$1.65.

Greenhouse and Window Plants. CHARLES COLLINS. London and New York, Macmillan & Co. 1895. Pp. x+160. 40 cts.

The Production of Coal in 1894. EDWARD WHEELER PARKER. From the Sixteenth Annual Report of the Director of the U. S. Geological Survey, Washington, 1895. Pp. 224.

SCIENCE

NEW SERIES.
VOL. II. No. 42.

FRIDAY, OCTOBER 18, 1895.

SINGLE COPIES, 15 CTS.
ANNUAL SUBSCRIPTION, \$5.00.

GUSTAV E. STECHERT'S Recent Importation of Scientific Books.

ADICKES, DR. ERICH. Kant-Studien. 185 Seiten. gr. 8°. Mk. 4⁰⁰.

BENEDIKT, DR. MOR. Die Seelenkunde des Menschen als reine Erfahrungswissenschaft. 372 Seiten. 8°. Mk. 6⁰⁰.

BERNBACH, DR. W. Der elektrische Strom und seine wichtigsten Anwendungen in gemeinverständlicher Darstellung. Mit 90 Abbildungen. 108 Seiten. 8° Mk. 2⁰⁰.

BIEDERMANN, W. Elektrophysiologie. 1^{te} Abtheilung. Mit 136 Abbildungen. 440 Seiten. 8°. Mk. 9.

BOEGLE, DR. C. Die Entstehung organischer Formen. 18 Seiten. 8°. Mk. 1⁵⁰.

CAPITAINE, EMLL. Das Wesen des Erfindens. Eine Erklärung der schöpferischen Geistesthätigkeit an Beispielen planmässiger Aufstellung u. Lösung erfinderischer Aufgaben. 135 Seiten. 8°. Mk. 3⁰⁰.

DELAGE, YVES. La structure du protoplasma et les théories sur l'hérédité et les grands problèmes de la biologie générale. 875 pages. gr. 8° cloth. frs 24⁰⁰.

DÜHRING, DR. E. Wirklichkeitsphilosophie, Phantasmenfreie Naturergründung und gerecht freiheitliche Lebensordnung. 554 Seiten. 8°. Mk. 9⁰⁰.

FOREL, DR. AUGUST. Der Hypnotismus, seine psycho-physiologische medicinische, strafrechtliche Bedeutung und seine Handhabung. 3^{te} verb. Aufl. mit Annotationen von Dr. O. Vogt. 223 Seiten. gr. 8°. Mk. 5.

FRICKS, DR. J. Physikalische Technik speciell Anleitung zur Ausführung physikalischer Demonstrationen und zur Herstellung von physikalischen Demonstrations-Apparaten mit mögl. einfachen Mitteln. 6^{te} umgearb. und verm. Aufl. von Dr. Otto Lehmann. II. Band. Illustriert. 1054 Seiten. gr. 8°. Mk. 20⁰⁰.

GRIESBACH, PROF. DR. H. Physicalisch-Chemische Propädeutik unter besonderer Berücksichtigung der medicin. Wissenschaften u. mit histor. und biographischen Angaben. 1^{ste} Hälfte. Bogen 1-17 mit Figur 1-44. gr. 8°. Mk. 5⁰⁰.

HAACKE, DR. WILH. Die Schöpfung des Menschen und seiner Ideale. Ein Versuch zur Versöhnung zwischen Religion und Wissenschaft. Mit 62 Abbildungen im Text. 487 Seiten. gr. 8°. Mk. 12⁰⁰.

HAMPE, DR. JULIUS. Ueber Geisteskrankheiten in Folge Schwefelkohlenstoff-Vergiftung. 51 Seiten. 8°. Mk. 1⁶⁰.

HANSEN, DR. EMIL CHR. Untersuchungen aus der Praxis der Gährungsindustrie. Beiträge zur Lebensgeschichte der Mikroorganismen. 3^{te} verm. u. neubearb. Aufl. mit 19 Abbildgn. Heft I, 92 Seiten. gr. 8°. Mk. 3⁵⁰.

HALLIER, DR. ERNST. Die Pestkrankheiten (Infectionskrankheiten) der Kulturgewächse. Nach streng bakteriologischer Methode untersucht und in völliger Uebereinstimmung mit Robert Koch's Entdeckungen geschildert. Mit 7 Tafeln. 144 Seiten. Text. gr. 8°. Mk. 8⁰⁰.

HITZIG, DR. ED. Ueber den Quärlantenwahn-sinn, seine nosologische Stellung und seine forensische Bedeutung. Eine Abhandlung für Aerzte und Juristen. 146 Seiten. gr. 8°. Mk. 5⁰⁰.

JAHR, HANS. Grundriss der Electrochemie. 311 Seiten. gr. 8° Mk. 8⁰⁰.

KROMPECHER, EDMUND. Die mehrfache indirekte Kerntheilung. Mit 9 lithogr. Tafeln. 275 Seiten. gr. 8°. Mk. 4⁰⁰.

LEHMANN, DR. O. Electricität und Licht. Einführung in die messende Electricitätslehre und Photometrie. Mit 220 Holzstichen u. 2 Tafeln. 390 Seiten. gr. 8°. Mk. 7⁰⁰.

NOLDE, BARON EDUARD. Reise nach Innerarabien, Kurdistan und Armenien 1892. Mit dem Bildniss des Reisenden und 1 Karte. 272 Seiten. 8°. Mk. 4⁵⁰.

Pharmakologie und Toxikologie mit Beiträgen von vielen Ärzten redigirt von A. Brestaniski. 967 Seiten. gr. 8°. Ludbd. M. 25⁰⁰.

RICHTER, CARL. Die Galvanische Verzinkung des Eisens. Mit besonderer Berücksichtigung der neueren Methoden. Mit 18 Figuren im Text. 48 Seiten. 8°. Mk. 1⁵⁰.

SCHMIDT, DR. CARL. Das Naturereigniss der Sintflut. Akademischer Vortrag. 63 Seiten. 8°. Mk. 1²⁰.

WELTER, DR. ADOLF. Die Tiefen Temperaturen, ihre künstl. Erzeugung, ihre Einwirkung auf Tiere, Pflanzen, Microorganismen, etc., sowie ihre Anwendung in der Industrie. 84 Seiten. gr. 8°. Mk. 2⁵⁰.

ZITTEL, KARL A. VON. Grundzüge der Paläontologie (Paläozoologie). Mit 2048 in den Text gedruckten Abbildungen. 971 Seiten. gr. 8°. $\frac{1}{2}$ mor. Mk. 25⁰⁰.

ZWAARDEMAKER, DR. H. Die Physiologie des Geruchs. Mit 28 Figuren im Text. 324 Seiten. gr. 8°. Mk. 9⁰⁰.

GUSTAV E. STECHERT,

810 Broadway, New York.

Macmillan & Co.'s New Publications

Mayo-Smith—Statistics and Sociology. Science of Statistics, Part I.

By RICHMOND MAYO-SMITH, Ph. D., Professor of Political Economy and Social Science in Columbia College. 8vo, cloth, \$3.00 net. (New volume of the *Columbia University Press*.)

Watson—Hedonistic Theories, from Aristippus to Spencer.

By JOHN WATSON, Professor of Moral Philosophy in the University of Queen's College, Kingston, Canada. 12mo, cloth, \$1.75 net.

Loney—The Elements of Co-ordinate Geometry.

By S. L. LONEY, M. A., late Fellow of Sidney Sussex College, Cambridge. Pp. x.+416, 16mo, cloth, \$1.25 net.

Eccles—The Practice of Massage: Its Physiological Effects and Therapeutic Uses.

By A. SYMONS ECCLES, M. B. Aberd., Member Royal College Surgeons, England; Fellow Royal Medical and Chirurgical Society, London; Member Neurological Society, London, etc. 8vo, cloth, pp. xii.+377, \$2.50 net.

Lassar-Cohn—A Laboratory Manual of Organic Chemistry: A Compendium of Laboratory Methods for the Use of Chemists, Physicians and Pharmacists.

By DR. LASSAR-COHN. Translated, with the author's sanction, from the second German edition. ALEXANDER SMITH, B. Sc., Ph. D. Pp. ix.+403, 12mo, cloth, \$2.25 net.

Bastable—Public Finance.

By C. F. BASTABLE, M. A., LL.D., Professor of Political Economy in the University of Dublin. Second Edition. Revised and enlarged. 8vo, cloth, \$4.00 net.

Stanley—Studies in the Evolutionary Psychology of Feeling.

By HIRAM M. STANLEY, Member of the American Psychological Association. 8vo, cloth, \$2.25 net.

Keith—Plea for a Simpler Life.

By GEORGE S. KEITH, M. D., F. R. C., P. E. 12mo, cloth, \$1.00.

The Rural Science Series.

Edited by L. H. BAILEY. *New Volume.*

King—The Soil. Its Nature, Relations and Fundamental Principles of Management. By F. H. KING, Professor of Agricultural Physics in the University of Wisconsin. 16mo, cloth, 75 cents.

The Century Science Series.

Edited by SIR HENRY E. ROSCOE, D. C. L. *New Volume.*

Justus Von Liebig: His Life and Work. (1803-1873.) By W. A. SHENSTONE, F. I. C., Lecturer on Chemistry in Clifton College. With Portrait. 16 mo, cloth, \$1.25.

MACMILLAN & CO., 66 Fifth Avenue, New York.

SCIENCE

EDITORIAL COMMITTEE: S. NEWCOMB, Mathematics; R. S. WOODWARD, Mechanics; E. C. PICKERING, Astronomy; T. C. MENDENHALL, Physics; R. H. THURSTON, Engineering; IRA REMSEN, Chemistry; J. LE CONTE, Geology; W. M. DAVIS, Physiography; O. C. MARSH, Paleontology; W. K. BROOKS, Invertebrate Zoology; C. HART MERRIAM, Vertebrate Zoology; S. H. SCUDDER, Entomology; N. L. BRITTON, Botany; HENRY F. OSBORN, General Biology; H. P. BOWDITCH, Physiology; J. S. BILLINGS, Hygiene; J. MCKEEN CATTELL, Psychology; DANIEL G. BRINTON, J. W. POWELL, Anthropology.

FRIDAY, OCTOBER 18, 1895.

GEOLOGY AT THE BRITISH ASSOCIATION,
1895.

CONTENTS:

| | |
|---|-----|
| <i>Geology at the British Association:</i> W. W. WATTS. | 493 |
| <i>A Course of Astronomy for Engineering Students:</i> GEORGE C. COMSTOCK. | 502 |
| <i>How Far shall the Periodic Law be Followed in Teaching Chemistry?</i> F. P. VENABLE. | 506 |
| <i>The Status of the Solar Magnetic Problem:</i> FRANK H. BIGELOW. | 509 |
| <i>Current Notes on Physiography (XVI.):</i> — | 514 |
| <i>Russell's Lakes of North America; A Seiche in Lake Superior; Bathymetry of the English Lakes; Diurnal Variation of River Volume and Velocity; Geography in Normal Schools:</i> W. M. DAVIS. | |
| <i>Scientific Notes and News:</i> — | 516 |
| <i>The Ipswich Meeting of the British Association; The Brooklyn Institute of Arts and Sciences; General.</i> | |
| <i>University and Educational News</i> | 520 |
| <i>Correspondence:</i> — | 521 |
| <i>Professor Brooks on Consciousness and Volition; E. D. COPE. Absorption of Terrestrial Radiations by the Atmosphere: W. HALLOCK. A Reply: GEORGE BRUCE HALSTED. The Rudolf Leuckart Celebration: CH. WARDELL STILES. To Those Interested in Quartertons and Allied Systems of Mathematics: P. MOLENBROEK and S. KIMURA.</i> | |
| <i>Scientific Literature:</i> — | 525 |
| <i>Proceedings of the International Electrical Congress, Chicago; HENRY S. CARIART. The Alps from End to End. W. M. D. Merriman's Handbook for Surveyors.</i> | |
| <i>Scientific Journals:</i> — | 527 |
| <i>The Monist. The Journal of Comparative Neurology.</i> | |
| <i>Societies and Academies:</i> — | 528 |
| <i>The New York Academy of Sciences: J. F. KEMP. The Texas Academy of Science.</i> | |

MSS. intended for publication and books, etc., intended for review should be sent to the responsible editor, Prof. J. McKeen Cattell, Garrison on Hudson, N. Y.

Subscriptions and advertisements should be sent to SCIENCE, 41 N. Queen St., Lancaster, Pa., or 41 East 49th St., New York.

THE British Association for the Advancement of Science held its sixty-fifth meeting this year at Ipswich, the chief town in Suffolk, in the east of England, the district in which the Pliocene rocks of the country are best developed. The Section of Geology was presided over by Mr. W. Whitaker, who was engaged for many years in mapping these rocks for the Geological Survey. The address delivered by this gentleman on the opening day, September 12th, naturally dealt with local problems, and especially those raised by the numerous deep borings for coal and water which have been put down through the rocks of eastern England.

Neglecting deposits newer than the Gault, the variations of which are slight and of but little consequence, he notes that the Lower Greensand has only been met with in one boring, that of Culford, where it is 32 feet thick and of anomalous character, preparing us for the thinning out which occurs elsewhere. Jurassic rocks are only present in the southern borings and do not occur in Suffolk. Under the Jurassic or Cretaceous rocks the Trias is supposed to occur in one case and in the others strata belonging to the Carboniferous, Devonian and Silurian Systems. In five bores out of ten put down under the London Basin the determination of the age of the rocks is aided by fossil

evidence, but in the rest this support is wanting. The general result is to prove that over an area not less than 86 miles from northwest to southeast older rocks almost certainly occur everywhere at a distance of not more than 1600 feet from the surface.

The only boring in eastern England which has struck productive Coal Measures is that at Dover, where evidence from the Continent was at hand to aid in fixing the exact position for the trial locality, but two or three others have struck Carboniferous rocks at a horizon below that at which workable coals are usually found, thus proving that there are Carboniferous rocks in the eastern counties, and showing that there is every likelihood of eventually meeting with productive measures if exploration is persisted in. The Stutton experimental boring, on which the President read another paper in the course of the meeting, after passing through 1000 feet of Neozoic rock had struck on Palæozoic rock and was being continued through it in the hope that some satisfactory evidence of the age of the latter rock would be forthcoming. It had then reached the depth of 1350 feet and the lithological character of the rock resembled Carboniferous or Ordovician shale. The section of the bore hole is given below :

| | Feet. |
|---|-------|
| Drift (River Gravel)..... | 16 |
| London Clay and Reading Beds..... | 54 |
| Upper and Middle Chalk..... | 720 |
| Lower Chalk, with very glauconitic marl at the base (almost a green sandstone)..... | 154½ |
| Gault | 49½ |
| Palæozoic Rock' with a high dip. | |

In conclusion Mr. Whitaker stated that, even if it was necessary to abandon the present experiment, it was intended to make one or possibly two more trials, so as to have a fair chance of really settling the

question of the occurrence of coal in East Anglia. Taking up the question thus prominently brought forward by the President, Mr. Harmer advocated that the systematic survey of deep-seated rocks by means of borings should become one of the duties of the Geological Survey. Anticipating that valuable economic discoveries of coal, water, iron and other products were only a question of time, he stated that the starting of new industries in agricultural districts, the appreciation in the value of land, and if necessary the imposition of a royalty on minerals worked beyond a certain depth, would far more than pay the expenses of such systematic work, whilst, under the present state of the law, no private individual cared to undertake deep exploration, because his very success would only bring him into competition with those who would profit by his discoveries without sharing his risks.

Mr. Whitaker likewise contributed to the Section a paper on deep wells in Suffolk ; six of these penetrate the Tertiary rocks and reach the chalk.

A paper of very great importance was that by Mr. Joseph Francis on methods for determining the direction of dip in strata at the bottom of deep borings, methods which have proved quite successful at depths of 1,000 feet and might be applied to almost any depth. The author had carried out his experiments at the borings at Ware and Turnford, and, after abandoning plans dependent on fastening a compass needle on the top of the core, he fell back on the method of lowering the rods with the utmost care to prevent twisting, and checking the result by equally careful raising and the lifting of wax moulds of the top of the core. The crown of the boring-tool was furnished interiorly with three sharp steel points so arranged as to give a line in a known direction; these points on descending ruled three lines on the side of the core

which was then broken off, lifted, and the angle of the diametral line with the direction of dip measured. A test experiment was also arranged by grinding the surface of the next piece of core and impressing a line of points on it by lowering a steel bar armed with punches on to the smooth surface; on raising this core it yielded a measurement within a degree of the preceding observation. The Palaeozoic rocks at Ware and Turnford gave dips a little west of south.

Owing to the presence of many observers who had worked in East Anglia, local papers were numerous. First came two by Mr. Harmer, a gentleman who was for many years the colleague of Mr. Searles Wood, Jun. One dealt with the commonly occurring species of Mollusca of the Coralline Crag deposits and showed that this assemblage, even better than the total fauna, proved the southern derivation of the organisms. The summaries given by him are printed below:

Summary of the abundant and characteristic species of Mollusca occurring in the Coralline Crag.

| | |
|--|-----|
| Not known as living (37 per cent)..... | 89 |
| Living in distant seas..... | 8 |
| Living in the Mediterranean..... | 133 |
| Living in the West European area..... | 9 |
| Living not south of Britain..... | 1 |
| Total..... | 240 |

Species of European Mollusca occurring abundantly in the Coralline Crag.

| | |
|---|-----|
| Southern and not British (28 per cent)..... | 42 |
| British (rare) and Southern..... | 9 |
| (35 per cent)..... | 51 |
| British (characteristic) and Southern..... | 91 |
| British and not Southern..... | 1 |
| Total..... | 143 |

Mr. Harmer's second paper dealt with the so-called derivative shells in the Red Crag; while admitting that the Eocene species had

undoubtedly been derived from an older deposit, the author contended that many of these shells had lived in Britain in much later times, some belonging to the interval which elapsed between the formation of the Red and Coralline Crag. Mr. Clement Reid gave an illustrated lecture on the glacial deposits of Cromer, which were visited later on by a large party under his guidance. The Cromer drift is remarkable for the contortions which it exhibits, and, indeed, it frequently displays all the structural phenomena of the crystalline schists, being sheared, crumpled, brecciated, twisted and kneaded into 'eyes.' The same author in conjunction with Mr. H. N. Ridley described the discovery of a new bed containing temperate plants between the moraine deposits and those with arctic plants at Hoxne, a locality long famous for the palaeolithic implements found in its upper strata; he proposes to investigate this deposit still further and to determine the relation of the human remains to the various climates indicated by the plants and moraines.

The following is the section exposed :

| | |
|--|-------|
| | Feet. |
| Gravelly surface soil..... | 2 |
| Brick earth; towards the base <i>Valvata piscinalis</i> , cyprids, bones of ox, horse, elephant (?), and palaeolithic implements | 12 |
| Sandy gravel, sometimes carbonaceous, with flint flakes | 1 |
| Peaty clay, with leaves of Arctic plants (?)..... | 4 |
| Lignite, with wood of yew, oak (?), white birch, seeds of cornel, etc..... | 1 |
| Green calcareous clay, with fish, <i>Valvata piscinalis</i> , <i>Bythinia tentaculata</i> , cyprids, <i>Ranunculus repens</i> , <i>Carex</i> | 4 |
| Boulder clay..... | 4 |

Recent storms at Southwold, on the east coast, have effected considerable denudation there and have directed attention to

the amount of this action which is measurable within recent years; Mr. Spiller estimates this amount to vary between 10 and 84 feet in six years at different points along the coast. Mr. H. B. Woodward describes the section exposed by the storm just mentioned: Norwich Crag below the Chalky Boulder Clay, and above that a bed containing fresh water shells followed by a peaty deposit.

A paper by M. G. F. Dollfus, on the probable extension of the seas during Upper Tertiary times in western Europe, is so important that we give a full abstract of it:

Taking into consideration the positive nature of all the outliers of Upper Tertiary age, the author is led to the following conclusions as to the extension of the Neogenic seas in western Europe. During Miocene times England was united to France, and we have proof of the existence of two seas in the western part of Europe; one on the east extended over part of Belgium (Bolderian system), Holland, and north of Germany—probably this sea was not very far off the eastern coast of England; the other sea, the Western, or old Atlantic Sea, was off Ireland, penetrating in various gulfs into France, as in some part of Cotentin, Brittany, in the Loire valley, in the Gulf of the Gironde, but there was no way of communication with the Mediterranean basin crossing France. In north Spain there are no Miocene deposits; in Portugal Miocene beds are purely littoral.

The communication with the Mediterranean Sea was certainly by the valley of the Guadalquivir. The Gibraltar Strait had not exactly its present place. The fauna of these Miocene coasts was warm and very similar to the existing fauna of Senegal and Guinea.

We can divide Pliocene time into three periods, but the situations of the seas were not very different. England was always in direct continental communication with

France, the English Channel was not open at all. All the Pliocene deposits of Belgium, north France, or England, even the Lenthams beds, are on the side of the North-Eastern Sea; we find all these patches on the northern side of the great anticlinal line of the Artois, Boulonnais and Weald. The fauna is different from the Miocene, and colder; it even turns more and more cold during the progress of Pliocene time. On the western or Atlantic side we have little gulfs, leading the sea into the land, but not so frequently and not so far as during Miocene times. The Cornwall deposits, Cotentin beds and the Brittany patches are very limited; the basin of the Gironde contains no trace of Pliocene beds, and we have no trace of recent marine beds at the foot of the Pyrenees. In the north of Spain there is also no trace of Pliocene beds. The continent seems to have been higher, and the Atlantic tolerably distant. All the Portuguese sands recently discovered are littoral, and only on the Algarve coast and south of Spain do we find proof of the probable communication with the Mediterranean. The Gibraltar Strait was not always in the same place during Pliocene time; in the beginning probably the Guadalquivir valley to Murcia continued to be the strait, but later the rock of Gibraltar was separated from Africa and a new road was open; this way was certainly deeper than the former one, and as deep as the existing strait. By this depression the cold fauna of the depths of the Atlantic penetrated into the Mediterranean Sea as far as Sicily and Italy with *Cyprina Islandica*.

The geology of Morocco is unknown, but we have plenty of information on Algeria. We have there great Miocene deposits raised along the Atlas Chain up to a great altitude, and a little lower a good and very long band of Pliocene beds of marine and continental origin. Quaternary deposits, similarly continental and littoral, occur lying along

the actual coast, pointing out the south side of the Mediterranean connection.

In a few words, the English Channel has been opened very recently, and no sea occupied its place before. No sea has crossed France or central Spain, and we are obliged to seek for an outlet for the Eastern Sea during Miocene time by way of Germany, Galicia and south Russia, or by the north of Scotland.

During the existence of the Pliocene seas there was no other communication for the Crag seas than the northern one, for the western, the south and eastern sides were undoubtedly shut in by land.

M. Van den Brœck followed with a note on the present state of our knowledge of the Upper Tertiary strata of Belgium. He had determined that the Upper Oligocene strata did not exist in Belgium, but that the Upper Pliocene was probably present there. He concluded that the line of march of the Miocene fauna was from east to west, for Miocene forms present in Belgium were absent from England. That the Miocene formation had been once present in England he inferred from the fact that half the Belgian Miocene fauna was to be found in the Coralline Crag. M. M. Boule described some interesting finds in gravel in France, the deposit containing bones not only of *Elephas meridionalis*, but of *E. antiquus* and of the Mammoth, the former being in contact with palæolithic flints, the latter bearing tusks nearly three metres in length.

Several American gentlemen either read or sent papers to the meeting, including Professors Marsh, W. B. Scott, E. W. Claypole and Mr. R. B. White. The account of Professor Marsh's paper given by the *Times* is as follows:

"Professor Marsh described his restorations of some European Dinosaurs, and offered suggestions as to their place among the Reptilia. He said that he had examined nearly every specimen in Europe, and,

from minute comparison with the eight chief American types, mostly found in the Rocky Mountain regions, had restored four European forms, viz.: *Compsognathus*, *Scelidosaurus*, *Hypsilophodon* and *Iguanodon*. The Dinosaurs were all land animals, none being known as arboreal or aquatic. They varied in size from that of a chicken to gigantic monsters 80 ft. in length. Most were probably carnivorous; the *Iguanodon*, however, was herbivorous. The *Compsognathus* was found in the Jurassic Solenhofen slates near Munich. Its footprints resembled those he had shown Professor Huxley in the mud layers in the Connecticut Valley. Huxley considered them footprints, not of birds, but reptilian, and made by true Dinosaurs, and drew a bipedal animal about the size of a turkey conforming to the size of the footprints. It was a typical example of a true carnivorous Dinosaur. The *Scelidosaurus* was found in the Lias of England, a quadruped about 30 ft. long, with its back partly covered with a coat of mail. He had restored its fore feet by analogy with the quadrupedal *Stegosaurus ungulatus* of America, one or two specimens of which he had found, 30 ft. in length, just as the animal had fallen down to die, with every bone in position. The *Hypsilophodon* was found in the same geological formation. It had an ossified sternum, and in this respect differed from the American allied form. Much doubt had been entertained concerning the *Iguanodon* till the wonderful discovery of about 30 specimens in Belgium in their exact position at the time of death. As to the question of the true place of Dinosaurs amongst reptilia there had been great diversity of opinion. The crocodilian form *Hallopus* was regarded as a Dinosaur, but it differed from all other Dinosaurs in the long metatarsus and the backward projection of the calcaneum. But there were certain affinities between Dinosaurs and the crocodilian form

Aëtosaurus. The Dinosaurs were found at the base of the Jurassic strata. There was no evidence for their existence in the Tertiary period, but much against it. Owing to their appearance in the Wealden strata, if the evidence derived from Vertebrates is to be regarded as conclusive, the Wealden must be considered as belonging, not to the Cretaceous, but to the Jurassic formation."

Professor E. W. Clappole's paper on 'The Cladodonts of the Upper Devonian of Ohio' was as follows: Numerous specimens of the Cladodonts of the Cleveland Shale in Ohio have been found by Dr. Wm. Clark. They for the first time reveal to us the general form of the fishes to which belonged the teeth that have alone so long represented the genus *Cladodus*. The fossils are in very fair preservation, but their state of pyritization has obscured many of the details of their structure. So far as regards their form, however, we now know that they were long, slender fishes, resembling in their character the sharks of the present day; that they possessed well-developed and powerful pectoral and caudal, with weak ventral fins, the dorsals being unknown; that they were for the most part, or altogether, spineless; that at least one species possessed cladodont teeth of more than one pattern; and that they had near the hind end of the body a peculiar flat expansion or membrane of rudely semicircular form, which gave to the caudal extremity when seen from above the outline of a sharp-pointed shovel.

The largest whole specimen yet found shows a fish of about 6 feet in length, but detached teeth and other fragments indicate others of double this size, and supply abundant proof that in late Devonian times, and in the North American area, the elasmobranch fishes had attained very great proportions and a high stage of development.

Hitherto the Cladodonts have been regarded as, in the main, characterizing the

Lower Carboniferous rocks, but we now find them abounding in the earlier Devonian strata, and, as shown by the contents of their stomachs, preying, in some cases at least, on the smaller placoderms of the same area.

From the evidence of the new specimens it appears most likely that the species already defined from single and isolated teeth can no longer be maintained.

For details see the papers in the American Geologist for 1893-4-5.

Professor Clappole also read a second paper, illustrated with specimens on 'The Great Devonian Placoderms of Ohio.' The Upper Devonian Shales of Ohio have recently afforded a remarkable series of fossil fishes rivalling in size and interest those found many years ago in the Old Red Sandstones of similar age, in Scotland, and described by Agassiz and Hugh Miller. The earliest of these, *Dinichthys*, was closely studied, and its structure was well explained by the late Dr. Newberry. It was an immense armor-clad fish whose head measured from 2 to 3 feet in length. *Titanichthys*, the second of the group, though less massive, was of yet larger size. *Gorgonichthys*, the third, was described by the speaker in 1893, and, so far as is yet known, was the most formidable of all, possessing jaws of enormous size and thickness, above 24 inches long, ending in teeth or points from 6 to 9 inches in length. The last of the four, *Brontichthys*, of which a description was also published in the American Geologist for 1894, is equally heavy and of equal size, but differs from all the rest in possessing very massive symphysial portions in the mandibles with sockets apparently for the reception of teeth, as in *Titanichthys*.

Of the two last-named genera only the jaws are yet known with exactness. Other portions have been found of *Gorgonichthys*, but are still imbedded in the matrix. So far as can at present be determined, all the

four are closely related to *Cocosteus*, and belong to the same family.

The set of casts exhibited in illustration of the fossils has been prepared by their discoverer, Dr. William Clark, and faithfully represents the originals, of many of which only single specimens are yet known. The labor of extricating them from the pyritous shale has proved very heavy, and much yet remains to be done in this direction.

Professor W. B. Scott illustrated, with a large number of slides, his paper on 'The Tertiary Lacustrine Formations of America.' In Tertiary times one lake succeeded another, giving an almost complete record of that era in lacustrine deposits. Professor Scott suggested the annexed correlation of these deposits with the standard strata of Europe:—

| | | |
|----------------------------|----------------|--|
| 9. <i>Equus</i> beds | Pleistocene. | |
| 8. Blanco formation | Pliocene. | |
| 7. Loup Fork beds..... | Upper Miocene. | |
| 6. John Day beds..... | Lower Miocene. | |
| 5. White River beds..... | Oligocene. | |
| 4. Uinta beds. | Eocene { | Parisien. Suessionien. Cernaysien. |
| 3. Bridger beds. } | | |
| 2. Wasatch beds. } | | |
| 1. Puerco beds. } | | |
| | | |

A considerable break occurs between 3 and 4 and earth-movement then took place, while a second hiatus is seen between 6 and 7. 3, 5 and 7 are each divided into three divisions, and the highest division of the Loup Fork beds, the Palo Duro, may be correlated with the basal Pliocene. The Uinta beds were the evidence of the last lake west of the Rocky Mountains; the lakes afterwards spread east to the great plain.

The paper by Mr. R. B. White, 'On the Glacial Age in Tropical America,' described a number of apparently glacial deposits in the Republic of Colombia, almost under the equator. He spoke of moraines forming

veritable mountains, immense thicknesses of boulder clay, breccias, cement beds, sands, gravels and clays, beds of loess, valleys scooped, grooved and terraced, monstrous erratics and traces of great avalanches. It is a significant fact that over part of the area the author supposes the ice period to be contemporaneous with great volcanic activity, so that the glaciers bore on their surfaces little but loads of pumice, ash and ejected blocks; in other places, however, the detritus appears to have been derived from sedimentary rocks. The paper concludes with some remarkable speculations as to the cause of glacial periods.

Dr. H. Woodward read an interesting paper on some decapod crustaceans from the Cretaceous formations of Vancouver Island, in which he described four new species from specimens sent him by Mr. J. F. Whiteaves. These are named as follows: *Callianassa Whiteavesii*, *Palaecorystes Harveyi*, *Plagiophthalmus? Vancouverensis* and *Homolopsis? Richardsons*. Some of these forms approach very close to European Cretaceous types.

Turning now to the subject of palæontology, a paper which is fraught with far-reaching consequences in the near future, is that entitled 'Notes on the Phylogeny of the Graptolites,' by Professor H. A. Nicholson and Mr. J. E. Marr.

The authors note that the number of stipes possessed by graptolites has been looked upon as a character of prime importance, many genera being based on the possession of a certain number. Again, the 'angle of divergence' has been looked upon as an important factor in the diagnosis of families. They are, however, led to believe that a character of essential importance in dealing with the classification of the graptolites, and one which, in all probability, indicates the true line of descent, is found in the shape and structure of the hydrothecæ, the point of next importance as indi-

eating genetic relationship being the 'angle of divergence.'

These views are illustrated by reference to forms belonging to the 'genera' *Bryograptus*, *Dichograptus*, *Tetragraptus* and *Didymograptus*, which appear in turn in this sequence.

Out of nine *Tetragrapti* (and the authors know of no other forms referred to this genus which are represented by well-preserved examples), eight are closely represented by forms of *Didymograptus*, which are closely comparable with them as regards characters of hydrothecæ and amount of 'angle of divergence,' whilst the ninth is comparable with a *Didymograptus* as regards 'angle of divergence' only. Moreover, four of the *Tetragrapti* are comparable as regards the two above-named important characters with forms of *Dichograptus* and *Bryograptus* with eight or more branches, and the authors confidently predict the discovery of forms belonging to these or closely allied many-branched 'genera,' agreeing with the remaining *Tetragrapti* in what they regard as essential characters.

They give details showing the points of agreement of each group of the various series, including a two-branched, a four-branched, and a many-branched form, and point out how difficult it is to understand how the extraordinary resemblances between the various species of *Tetragraptus* and *Didymograptus* (to take one example) have arisen, if, as usually supposed, all the species of the genera have descended from a common ancestral form for each genus, in the one case four-branched, and in the other case two-branched. On the other hand, it is comparatively easy to explain the more or less simultaneous existence of forms possessing the same number of stipes, but otherwise only distantly related, if they are imagined to be the result of the convergent variation of a number of different ancestral types. They allude to similar phenomena

which have been shown to exist amongst other organisms; thus Mojsisovicz has described analogous cases amongst the Ammonites, and Buckman (under the name of heterogenetic homœomorphy) amongst the brachiopods, though in this instance the cases of 'species' and not of 'genera' are considered.

Following the above inferences to their legitimate conclusion, the authors point out how 'genera' like *Diplograptus* and *Monograptus* may contain representatives of more than one 'family' of graptolites, according to the classification now in vogue, which would account for the great diversity in the characters of the monograptid hydrothecæ.

In conclusion, the authors offer a few theoretical observations upon a possible reason for the changes which they have discussed in the paper.

The latter of the foregoing authors, with Mr. E. J. Garwood, also read an important paper on the zoning of the Carboniferous rocks which they had begun in the north of England. The zones so far established were the following:

Zone of *Productus* c. f. *edelburgensis*.

Zone of *Productus latissimus*.

Zone of *Productus giganteus*.

Zone of *Chonetes papilionacea*.

Zone of *Spirifera octoplicata*.

Mr. Garwood has traced the zone of *P. latissimus*, occupying the same relative position to that of *P. giganteus*, from Settle, in Yorkshire, to the Northumbrian coast, near Howick Burn.

With regard to the other papers coming under this heading it will suffice to mention that the attempt to obtain the rest of the skeleton of the Oxford *Cetiosaurus* has not as yet met with any success, and that the report on fossil Phyllopora by Professor Rupert Jones contained a most valuable table by Professor Lapworth on the distribution of these organisms. The discovery of a new section of Rhætic rocks was de-

scribed by Mr. Montagu Browne, and Mr. Harrison reported on the flints, supposed by himself and others to have been worked by man, obtained from high level drift in Kent. Mr. Walford gave an account of the succession of rocks occurring between the Inferior Oölite and the Great Oölite in Oxfordshire as revealed by an excavation undertaken there within the year. In a paper on the auriferous conglomerates of Witwatersrand Dr. Hatch concluded that the gold must have been introduced into the rock subsequently to its consolidation, and not derived with the pebbles from an older formation.

Professor J. Milne, in an exceptionally interesting paper on earthquake phenomena, showed that the greater shocks could be felt by delicate instruments for enormous distances, even at their antipodes, and that the waves travelled faster than if the interior of the earth had the elasticity modulus of glass or steel. The observations of slight movements showed one regularly recurring set which the writer suggested might possibly be due to the evaporation of moisture by day and its deposit by night. The Committee engaged in collecting photographs of geological interest had amassed not less than 1,200, which were deposited at the Museum of Practical Geology at Jermyn St., London. Gradually this collection will form a most valuable and reliable survey of geological features and phenomena.

The committees on the erosion of sea coasts and on the circulation of underground water completed the labors on which they have been engaged for so many years, but still continue to act and now proposes to extend its scope to Scotland, where the local committee has ceased work for some years.

Amongst the papers on glacial subjects one of the most important was by Professor Sollas on artificial glaciers (or 'poissiers') made of pitch, and their bearing on the-

ories of glacier movement and transport. Troughs were prepared of various shapes and while these were inclined they were filled with pitch in such a way that when placed in position its surface had a slope of about 12 degrees. The pitch was put in in layers, various substances, such as rice, sago, pigment, etc., being placed on each layer as it was completed, to serve as indexes of the movements within the mass. In this way it was shown that against barriers opposed to the movement of the ice, an upward movement occurred like that which had long since been postulated by geologists to account for the upward transport of erratics. A similar upward movement also was detected in the pitch where it was driven into a narrow gorge. Another point illustrated was that pitch sometimes overrode heaps of loose materials just as glaciers are known to override their moraines. Pitch conformed to all the laws of fluid motion and differed only in the element of time, and it was found that practically similar results could be obtained with Canada balsam, glycerine and even water. This enabled Professor Sollas to project on the screen not only photographs of his results, but the actual experiments themselves taking place. The author had been able to imitate experimentally some of the phenomena recently described by Mr. Chamberlin.

Several papers dealing with old, pre-glacial valleys were read. One by Mr. Beeby Thompson called attention to the following varieties of such valleys: (1) New valleys without drift and having old, filled-up valleys near at hand; (2) Those that drift on one side and rock on the other; (3) Streams re-excavating old, drift-filled valleys; (4) Re-excavated valleys with the drift all washed down into gravel. Mr. E. Hill described a similar valley in Suffolk, and Mr. T. V. Holmes one in Essex.

Mr. P. Kendall and Mr. Lomas read a

remarkably interesting paper on modern glacial striae, of which unfortunately no report is available: Mr. W. W. Watts contributed a note on the basins of some of the tarns near Snowden. One very small one seemed to occur in a rock basin, one was dammed at both ends by scree and stream detritus, and two larger lakes, Glaslyn and Llyn Llydaw, were either confined in true rock basins or else were not more than about 40 feet deep.

A large number of excursions was planned and carried out chiefly under the leadership of the President and Mr. Clement Reid. The various localities for the Coralline and Red Crag deposits were visited and the relations of the deposits studied, and the last two days were devoted to a pretty thorough examination of the remarkable and classical glacial deposits of Cromer on the coast of Norfolk.

W. W. WATTS.

GEOLOGICAL SURVEY, LONDON.

A COURSE IN ASTRONOMY FOR ENGINEERING STUDENTS.

At the present time our engineering schools tend more and more strongly to technical curricula which deal with professional subjects to the exclusion of non-professional matters, and the author of the present paper, approving this tendency, purposes to state here his conception of a brief course in spherical and practical astronomy as a part of the technical training of the future engineer. The purposes of such a course should be:

(A.) To give the pupil some training in the precise use of instruments of precision. His course in surveying has given the student an introduction to the use of such instruments, but the nature of that work and the circumstances under which it is done preclude the placing of any considerable emphasis upon precision of results. To demand all the accuracy which a transit or level can be made to furnish is in general

bad surveying practice, but only the man familiar with refined methods of instrumental work is competent to form an intelligent judgment of the manner in which those methods should be modified and their rigor relaxed in any given case. The course in astronomy, therefore, comes as a supplement to that in surveying, and the pupil should now be taught:

(a.) That it is his business in each of his problems to obtain from his instrument all of the precision that it can be made to furnish.

(b.) He should be taught to obtain this precision with a minimum expenditure of care and time. The instinctive tendency of the student mind to execute every part of a given task with equal painstaking needs to be curbed and the pupil taught what things require minute care and what may be, and ought to be, dealt with in a summary manner.

(c.) As a subordinate matter he may be introduced to the use of instruments of a higher grade than those employed in his course in surveying.

(B.) A second purpose of the course is to train the student in the art of computing (ciphering). Model forms of record and reduction for his several problems should be placed before him and the advantage of compact and orderly arrangement of all numerical work should be strenuously insisted upon.

(C.) As the concrete outcome of the above training, the student should acquire the ability to determine latitude, time and azimuth with such instruments as he will use in the ordinary practice of civil engineering. The sextant and engineer's transit furnish quite as good an equipment for the course here contemplated as the elaborate outfit of an observatory. The latter belongs to a more advanced stage of study.

The details of a course of study such as is above suggested depend upon the amount

of time which can be assigned it in the curriculum, and as a compromise between conflicting interests we suggest a required course of sixty exercises, to be followed by an elective course, *which the student should have an opportunity to elect*, and for which he should receive credit.

THE REQUIRED COURSE. It is presupposed that the student is familiar, as a matter of common information, with the diurnal and annual motions of the earth and the rising and setting of stars. His technical instruction may begin with a formal definition of the zenith, poles, horizon, equator, meridian and an explanation of the coördinates, altitude, azimuth, declination, hour angle and right ascension, together with the geographical latitude and sidereal time, which should be introduced as concepts strictly analogous to the coördinates. An armillary sphere or some equivalent apparatus is almost essential to the ready acquisition of a working knowledge of the coördinates, and it will usually aid the student if emphasis is placed upon the fact that while any two coördinates suffice to fix the position of a star they naturally fall into pairs, altitude and azimuth, declination and right ascension, etc., the common element between the coördinates constituting a pair being that they refer to the same fundamental plane. It should be further noted that the latitude and sidereal time constitute the relationship between the different systems of coördinates, and it will be advantageous to point out the reasons for employing several different systems.

The astronomical triangle, Pole-Zenith-Star, should next be introduced as a device for transforming coördinates from one system to another, and the student's interest will be stimulated if it is pointed out to him that the practical problems with which he is soon to deal, such as the determination of time, latitude and the direction of the meridian, are, in so far as their theory is

concerned nothing other than cases of the transformation of coördinates.

The convenient use of the astronomical triangle for the purposes here indicated requires a knowledge of the 'general spherical triangle,' and it will frequently be found that the student's mathematical attainments are in this respect insufficient. In such cases it is often an economy of time to devote an hour to the derivation of the general formulæ of spherical trigonometry by the transformation of rectangular coördinates, accompanying the demonstration with the requisite precepts for the application of these formulæ to numerical calculation. The student should apply the astronomical triangle to the derivation of formulæ for passing from each system of coördinates to each of the others, and should preserve these formulæ for use in the reduction of his observations rather than to resort anew in each case to the triangle.

At this stage of progress the student should devote some little time to the numerical transformation of coördinates, both for the purpose of familiarizing himself with the several systems and mode of passing from one to another, and for instruction in the technique of computing, the arrangement of his work, the checks against the commission of error, the mechanical devices for economy of time and labor, and the use of addition and subtraction logarithms, which are usually neglected in the department of mathematics.

It is a common saying among experienced computers that the only way to avoid mistakes in numerical work is to have acquired experience through the commission of every possible kind of blunder, and there is perhaps no part of his course in astronomy from which the future engineer will derive more practical advantage than this training under the guidance and criticism of an accomplished computer such as every professor of practical astronomy should be.

This training in numerical work should be a prominent feature of the whole course in astronomy, and without more than a beginning in such work the student may pass to a consideration of the different kinds of time in the order, sidereal, apparent solar, mean solar time, and should learn the use of the ephemeris in so far as it deals with the concepts he has had occasion to employ. He will learn that the various quantities contained in the ephemeris are all variable with the time; that their values which he is to use must be interpolated from it for the instant at which the observation in question was made, and that this instant must be expressed in Washington or Greenwich time. This seems an exceedingly elementary matter, but it is the writer's experience that students are frequently perplexed by it and that a little care is required for its elucidation.

The order in which the student shall take up his practical problems is not a matter of primary importance, but it has been found convenient in practice to assign first the determination of time from a single altitude, or series of altitudes, of the sun, measured with the sextant, showing the student how to use the instrument and explaining its chief sources of error without going into their mathematical theory. The reduction of these observations brings the student to a consideration of the fact that the altitude which he has measured cannot immediately be employed with the latitude and declination of the sun for the solution of the astronomical triangle, but must be first transformed from an apparent into a true altitude by correcting for the effect of refraction and parallax.

The theory of the parallax may be briefly given, neglecting the earth's compression, but it will usually be better to give arbitrarily the refraction formula than to attempt its derivation. The student will usually have difficulty in determining which limb

of the sun he observed, and his perplexity may be used to emphasize the advantage of observing both the upper and lower limbs. So also he will usually require some stimulus to secure the bestowal of sufficient attention upon the determination of the index correction.

The next step in his progress may be a rapid revision of the theory of the theodolite or engineer's transit which he encountered, but usually did not master, in connection with his course in surveying. This work should include the measurement of angles by repetition, the effect of a reversal of the instrument in eliminating its errors, the method of employing its plate and striding levels, and the mode of eliminating the effect of graduation errors. If an instrument with micrometer microscopes is available, instruction in its use may be given at this point and the instrument first employed for measuring the zenith distance of a terrestrial mark. It is advantageous to throw the alidade level somewhat out of adjustment, in order to impress upon the student that the reversal of the instrument eliminates all defects of this kind from the measured zenith distance.

Although not strictly germane to a course in astronomy, the subject of trigonometric levelling with the effect of refraction and the curvature of the earth's surface may be introduced here with advantage.

In his measurements of zenith distance the student should be taught to bring the level bubble somewhere near the middle of its scale, but not be allowed to spend much time in getting a nice adjustment of it, reading the level and subsequently applying its indications as a correction to the circle readings. This requires a knowledge of the value of a level division, and the student should be required to determine this value by whatever method his instructor deems most convenient.

Passing on to astronomical uses of the

theodolite, the student may determine latitude from circum-meridian altitudes of the sun (Gauss' mode of reduction) and azimuth from simultaneous readings of the vertical and horizontal circles when the line of sight is directed to the sun, combined with readings of the horizontal circle when the telescope is directed upon a terrestrial mark. This mode of determining azimuth, although very much neglected in the text-books, admits of considerable precision and is excellently adapted to the purposes of the engineer.

Thus far the student's problems have involved only work by daylight, but he should now take up night work and will require some instruction about illuminating the wires of his instrument and in reading verniers, levels, etc., by lamplight. His first problem should be the simultaneous determination of time and latitude from equal altitudes of Polaris and southern stars. This method is very little used in America, but it is the best method of using an engineer's transit for the determination of either time or latitude and should be taught to engineers. An exposition of the method with examples of its application has been given by the author of this paper in the *Bulletin of the University of Wisconsin, Science Series, Vol. I., No. 3.*

An average student with a good transit and ordinary watch may be expected within an hour to determine his latitude within 2" and the error of his watch within a quarter of a second.

The limits of time above allotted permit the assignment of only one more problem in our course, the determination of azimuth from observations of a close circum-polar star. The student should be taught that while it is advantageous to observe at elongation it is by no means necessary to do so, and that by a proper combination of stars, together with an approximate determination of time, he may frequently avoid

the necessity of observing at inconvenient hours without in any way impairing the precision of his results.

In outlining the above required course, to be given in sixty exercises, or less, no reference has been made to a text-book, and the author knows of no text-book which is altogether satisfactory. In giving at the University of Wisconsin the equivalent of the course above outlined it has been his practice to prepare cyclo-style copies of lecture notes covering the ground to be traversed by the class and including in detail the record and reduction of a set of observations corresponding to each problem assigned the student. A copy of these notes is placed in the hands of each student and he is expected to familiarize himself with the text contained in them and to use the numerical parts as models for the record and reduction of his own observations. These observations and their reduction written up in a note-book and accompanied by the requisite formulæ are preserved by the student as guides for any future work of the kind which he may have occasion to do. This mode of instruction, however, cannot be regarded as altogether satisfactory, and a suitable text-book would presumably strengthen the course.

It does not fall within the scope of this paper to provide in detail an advanced elective course in astronomy. As our schools are organized such a course must be arranged to meet the requirements of each individual case, but the material available for such a course in a properly equipped engineering observatory may be indicated as follows:

The Transit Instrument. Determination of time in the meridian. Investigation of the constants of the instrument. Determination of azimuth by mounting the instrument in the vertical of a circum-polar star near elongation.

Clocks and Chronometers. Comparison

of. Investigation of rates and temperature coefficients.

The Zenith Telescope. Investigation of constants. Determination of latitude.

The Universal Instrument. Refined determination of azimuth. Latitude from altitudes of stars. Time from transits over the vertical circle of Polaris, Doellen's method.

Transit Instrument in the Prime Vertical. Determination of latitude and declinations of stars.

The prosecution of such a course of study necessarily implies a considerable addition to the student's theoretical knowledge, and concurrently with his instrumental work he should take up in the standard treatises such subjects as precession, nutation, aberration, refraction, the reduction of star places, etc.; but we here approach, if indeed we have not already passed, the bounds which separate engineering study from the domain of the professional astronomer.

The points at which the writer of this paper seeks to place special stress are that a brief course in spherical and practical astronomy is properly a part of the professional training of every engineer in whose work surveying is to occupy an important place, and that this instruction can be advantageously given with no further instrumental equipment than that possessed by every good school of engineering.

GEORGE C. COMSTOCK.

UNIVERSITY OF WISCONSIN.

HOW FAR SHALL THE PERIODIC LAW BE FOLLOWED IN TEACHING CHEMISTRY?

MORE than a quarter of a century has passed since Mendeleeff announced the Periodic Law. Any one who critically surveys this period will be forced to admit that this discovery has been the most fruitful of results of any since the Atomic Theory, and I believe we are just beginning to realize the value of this Natural Law

and to have some idea of the fulness of its true meaning.

Chemists have shown themselves very conservative in the adoption of such discoveries and the ordering of their science by means of them, but it seems that in this case they have carried their conservatism too far. And perhaps this conservatism has not always been that which springs from a careful guarding against the possibly false and misleading, but rather from mental inertia and a dislike of giving up the old and learning the new.

The Natural Law, if true, introduces some most radical changes into the science. It is in a measure subversive of the old. It is impossible to cling to the old system while ascribing high praise to the Periodic Law, as is done in so many of our textbooks.

If this law is true it must dominate all of chemistry. Its statements are fundamental and all-embracing. It cannot consent to share its authority with the old system. There can be no half-way measures. Just in so far as it is accepted as proved it must be incorporated into the science. The custom has been to teach chemistry to beginners very much in the old style, and then to give a short time to explaining the Periodic Law, instead of teaching the science with this as the very foundation.

It is manifestly the duty of a conscientious teacher to satisfy himself as to how far this law is true, and then to make all possible use of it in his teaching, as he does of the Atomic Theory itself. If it is false reject it, if true let it be the foundation of your system of instruction.

Now let me say, at the beginning, that for myself, I regard this law as incomplete in several of its details. But some points of prime importance may be regarded as settled.

1. That the elements are not distinct and separate individuals, but are more or less

closely related and must be treated in some measure as we treat the hydrocarbons. The degree and nature of the relationship is as yet unknown.

This idea of the inter-relationship of the elements must be at the bottom of all teaching of the science. I do not think it possible in the present state of our knowledge to lay very much stress upon that which is called periodicity, nor yet upon the degree of relationship as expressed by the atomic weight differences.

If too much stress is laid upon them in their incomplete state they may bring into doubt the great truths of the law.

2. The old division into metals and non-metals, or metalloids, is no longer permissible. It was always most arbitrary and indefensible, except on the grounds of convenience. It is no longer convenient, and being a false distinction it serves only to obscure the truth. I think some of the hesitation in accepting the Periodic Law has been due to the false ideas springing from this old-time division.

There is no such clear-cut division between the elements.

It would be contrary to the fundamental idea of their kinship. They must be taught by groups and the gradation of positive to negative tendencies pointed out along with the change of atomic weight and of valence.

3. It is clear that, if these elements are related and show a certain gradation in properties and the old idea of their separate and distinct individuality is to be given up, then the proper classification for the salts is under the head of the acid which mainly determines their nature and not, as in the old way of teaching, under the head of each metal. Mineralogists long ago seized upon this as the simplest and most natural way of classifying minerals, but chemists have been slow to catch the idea. I can assure my fellow teachers, from my own experience, that time is saved, the subject made

clearer and the tax upon the memory lessened by this simple change of classification.

4. Valence and the gradations in it must be taught according to the natural arrangement. We cannot stand back because confronted with something which we cannot explain. Many of the facts of the science must be taught as facts leaving the explanation to those who are to follow us and to whom many of the things which are mysteries to us will be made plain.

It is just as well for the chemist of to-day to acknowledge that with all of the progress, of which he is justly proud, he is really only on the threshold of his science and that he is surrounded by the unknown on every side. What does he know of chemical force itself, of the nature of the atoms, of the character of this wonderful relationship, of valence and of many other problems?

I do not think the beginner should be tried too much with discussions of these problems nor with attempted explanations.

Such explanations are too subject to change. As to periodicity, I question the advisability of laying too much stress upon this feature of the Mendeleeff System in teaching Elementary Chemistry. It is true that the author makes this the first one of the eight conclusions drawn from his System but he speaks of it as an 'evident periodicity.' Every chemist who has examined into the matter will admit evidences of periodicity, but as the periods are irregular and not fully agreed upon, as the character of the periodicity varies and is unexplained, it is not wise, I repeat, to lay too much stress upon this feature yet awhile. The recurrence of elements of the same properties, that is periodicity, must be mentioned, but I would prefer to impress all this in a general way as a dependence of the properties upon the atomic weights. Still, I think, this is largely a personal matter. I do not like to teach with too

much dogmatism to young students half-discovered truths.

5. The system gives us certain typical elements. From these can be deduced the properties for the various members of the groups, and their treatment is greatly simplified. The old division into families, which was partial only, is broadened and filled out in the new groups.

6. I freely acknowledge that there are difficulties to be met. How could we expect it to be all plain sailing where our

I offer this only as possessing the value of success under personal trial.

I do not propose it as something free from objections, but merely as the best that I have been able to think out. I hope to improve it on further trial, and I trust that others will see and suggest improvements. The table was printed in the American Chemical Society's Journal for January, 1895.

My method, following Lothar Meyer's notable lecture before the German Chemical Society, is to preface the course with a dis-

| M ₂ O | | MO | | M ₂ O ₃ | | MH ₄ | | MH ₃ | | MH ₂ | | MH | | | | |
|------------------|----|----|----|-------------------------------|----|-----------------|----|-------------------------------|----|-----------------|----|-------------------------------|----|----|----|----|
| M ₂ O | | MO | | M ₂ O ₃ | | MO ₂ | | M ₂ O ₅ | | MO ₃ | | M ₂ O ₇ | | | | |
| Li | Be | B | C | N | O | F | | | | | | | | | | |
| 16 | 15 | 16 | 16 | 17 | 16 | 16 | | | | | | | | | | |
| Na | Mg | Al | Si | P | S | Cl | | | | | | | | | | |
| 16 | 40 | 16 | 41 | 17 | 43 | 20 | 44 | 20 | 44 | 20 | 47 | 20 | 45 | | | |
| K | Cu | Ca | Zn | Sc | Ga | Ti | Ge | V | As | Cr | Se | Mn | Br | Fe | Co | Ni |
| 46 | 45 | 47 | 47 | 45 | 43 | 42 | 45 | 43 | 45 | 44 | 47 | 47 | 47 | 46 | 47 | 48 |
| Rb | Ag | Sr | Cd | Y | In | Zr | Sn | Cb | Sb | Mo | Te | I | Ru | Rh | Pd | |
| 48 | 89 | 50 | 88 | 50 | 91 | 50 | 89 | 88 | 90 | 88 | | | 87 | 88 | 88 | |
| Cs | Au | Ba | Hg | La | Tl | Ce | Pb | Ta | Bi | W | | | Os | Ir | Pt | |
| | | | | | | 90 | | | | 54 | | | | | | |
| | | | | | | Th | | | | Ur | | | | | | |

knowledge is so incomplete and that which we suppose we know is often so inaccurate. It is sometimes difficult to assign an element to its proper group and one is especially troubled by what Blanshard has called 'Cross-Analogies.'

I believe the atomic weight is to be accepted as the final arbiter of arrangement in all cases.

I have prepared a table in which what I have regarded as the most prominent facts of the Natural System are presented.

cussion of water as a compound, air as a mixture, and the component elements. This gives the three classes of elements, compounds and mixtures, and some opportunity for fundamental laws. Then the table is given and its working explained.

All of the elements are then described in their proper order.

Then their hydrogen compounds, followed by the oxygen compounds. As each acid-forming oxide is reached, its salts with all the bases are given and described.

The system is simpler, clearer, saves repetition and time (five months instead of six and a half), is less burdensome to the memory, and gives a fairly uniform system for inorganic and organic chemistry. This in itself is an advantage not to be lightly estimated.

The table is not to be pushed too far—one must be careful not to go to lengths incapable of direct proof. The position in which the elements fall should not be used as having any reference to their genesis, derivation or composition.

As to graphic representations of the Natural System, I have examined all and rejected all as unsuited to teaching the science. All are open to the serious objection of carrying analogies too far, and leading the student on to deductions and dreams for which the chemist of to-day has no possible proof.

Take for example the pendulum oscillations of Spring and Reynolds, inseparably connected now with Crookes' speculation as to the Genesis of the Elements or take Preyer's condensation-steps and generation pyramids, all full of this idea of the genesis. Mendeleeff dismisses the idea of such curves of properties as Meyer devised, and there is much weight in his criticisms. Such curves are, at any rate, instructive only to those who are capable of reading mathematics critically.

I would counsel the use of the simple table without the questionable aid of curves or diagrams of any kind.

The summing up of the whole matter is this: If the Natural System is true it cannot be relegated to a side place in your teaching. It forms the basis of your entire course, and unless you utilize it you are occupying a false position and depriving yourself of the most valuable aid which the teacher of to-day has at his command.

F. P. VENABLE.

UNIVERSITY OF NORTH CAROLINA.

THE STATUS OF THE SOLAR MAGNETIC PROBLEM.

A SERIES of papers has been published in different journals during the past four years giving a very brief account of the steps taken in the investigation of the general problem of the transference of energy from the Sun to the Earth. It is probable that the main thread of the argument may be obscure to some readers for want of a consecutive statement of the case, and it is therefore proposed to summarize the evidence already obtained, as well as to indicate the nature of the scientific questions immediately at hand.

The research has been one of peculiar difficulty to successfully prosecute to definite conclusions, not because the line of operations was obscure, nor on account of the intricate mathematical conditions, but chiefly in consequence of the looseness of the phenomenon under consideration. By looseness is meant the wide deviations from the normal laws, whatever these may be, arising from the actual spasmodic actions of the sun on the one hand, and the very indirect effect of the solar energy thus generated upon the terrestrial, magnetic and meteorological fields, as recorded by the instruments employed in observations. This is an ordinary difficulty when the ether is the medium of the transference of energy between masses of matter widely separated in space, and in our case it is especially complex by reason of the complicated nature of the transmitter and the receiver, namely, the sun and the earth respectively. The solution of the problem must necessarily be by a system of approximations, in which unknown terms are carried hidden in the residuals during one operation, until the result obtained enables a repetition of the work under clearer conceptions. Also the complication of terms is so great that it is only by the successful treatment of an enormous mass of material that the im-

pressed force desired will emerge by the mutual destruction of other terms. Hence the work is laborious and the residuals small at the end of the first trip through the observations.

To obtain any result whatever it has been necessary to adhere closely to certain precepts, and also it has been requisite to learn to look beneath the apparent discordances of curves which purported, but on the surface seemed not, to be a record of the same fundamental pulsation. It was very natural that those who seek to verify the results of an investigator should expect to do so with a brief treatment of the material involved, and it could be easily shown that certain criticisms which have been published were based upon this process. Some highly discordant curves are shown as arguments against the truth of my conclusions, but in every case so far as known some of the precepts were violated and only a little material was used. Negative results to be valid against positive must be at least as exhaustive, both as to the concepts employed and the amount of material in evidence. In publishing conclusions it has been my practice to retain partially tested work till such advance had taken place as to become a pretty sure criticism of the results communicated, and it has therefore been regarded as conducive to the progress of the research not to complicate it with discussions of the negative arguments, which were obviously violating certain precise rules of procedure as yet unexplained to the public.

The ultimate goal of interest to the Weather Bureau is the improvement of the forecasts, whether in reading the daily maps or in predicting seasonal conditions for a year or more. Meteorology had contented itself with combinations of three forces, the earth's gravitation, the earth's rotation and equatorial insolation, acting upon the fluid atmosphere, in order to ex-

plain the observed effects in the motions of the air. The result has not satisfied students of the subject. The first point to determine was whether the sun did or did not transmit other energy to the earth, and, if it did, what kind of energy. The probability was that the auroras, the magnetic storms and earth currents, certain spasmodic actions in the electricity and magnetism of the earth's field and motions of the atmosphere, the sun spots and the coronal output, all belonged to one fundamental system, though no intelligible notion had been proposed that could explain the interrelation philosophically. The great distance of the earth from the sun seemed a barrier to one obvious explanation, so that the work was never seriously undertaken to test the validity of it.

My own attempts to solve the question of the meaning of the stream lines seen in the corona during an eclipse of the sun suggested and strengthened the working hypothesis that the whole unexplained system might be referred to the sun as a magnet in dynamic operation, and that live lines of magnetic force originating in the sun were propagated to the earth in wide sweeping curves, where the energy was expended in various operations, such as those just mentioned. Progress was also made in computing and mapping out the system of forces causing the diurnal and annual swings of the magnetic needles, which showed plainly that a complex field of mechanical forces besides gravitation surrounded the earth at its surface. Such forces must necessarily be referred to the electro-magnetic radiation of the sun, because the system was instantaneous and observations covering half a century could be combined without reduction for secular variation; and also because the entire system wanders up and down the earth with the change of the position of the axis of the field, as the sun moves in declination.

Furthermore, the fact that this field exhibits three compensating couples, fulfilling the laws of refraction when a permeable shell is placed within an external magnetic field, renders it certain that we have at last secured the basis of the complete solution of the ancient problem of the distribution of the earth's *quasi* permanent magnetism and its variation in short and long periods.

In order to distinguish the field of force that was supposed to produce the aurora and the other phenomena above mentioned, it was proposed to call it 'coronal,' or 'polar' radiation, in distinction from the sunlight, or equatorial radiation. It is radiation of some kind, if there is any transmission of energy through the ether from the sun to the earth, and it may be simply magnetic, or curved radiations, as opposed to rectilinear, or electro-magnetic radiation, the latter having been practically established as natural by the work of Maxwell and Hertz.

It was evident that if a solar-polar magnetic field existed and extended to the distance of the earth, its presence would be revealed by periodic variations, the period being determined by the synodic rotation of the sun, and the variations by the impressed energy due to the magnetic output on the several meridians. Also for the maintenance of such a normal field, whatever fluctuations it might undergo in itself, it was necessary to suppose that the nucleus of the sun is to some extent rigid, or at least non-vaporous. The detection of the synodic period and the approximate form of the curve representing the solar field at the distance of the earth followed, the period being 26.67-928 days, and the curve the one many times published. The period was found from the years 1878 to 1889, these containing the available European modern observations; since that time an application of the same period carried back from the epoch 1887 to the British Colonial Stations,

1841 to 1848, gives back the same curve, as if begun about one-tenth of a day later. Thus my first period is sufficient for a half century's work, and it is plain that a re-discussion of all the data will enable us to determine the rotation of the sun with extreme accuracy. Since we recognize the fact that the magnetic curves are a true and delicate register of solar action through at least 800 revolutions, it is clear that few natural phenomena have been so continuously recorded as the solar motion and in such detail. The same remark applies to the other physical manifestations of the energy of solar nucleus, if we learn to correctly interpret the changes in the magnetic curves. This unconscious contribution to solar physics by magneticians, through more than fifty years, is abundant justification of the faith in science that has inspired their work, and a sufficient answer to the cavilling question, *cui bono*.

The securing of the solar period was, of course, the foundation of progress in the classification of large masses of hitherto unworkable data. The illustration of its power is contained in the series of results thrust upon us by using it. At first the effort was made to detect a similar curve in meteorological and in solar phenomena by simply massing the observations in this period. The results were tantalizing, if not discouraging, for, while it was evident that a similar synchronous beat existed in the atmospheric elements, yet the residuals were so small, and the curves exhibiting them so rough, when compared with one another, that it seemed for a long while as if further progress might be impossible. However, by persistent study of successive periods during which no little practical skill was developed in detecting the underlying harmony in apparently unrelated curves, it was discovered that the normal curve was subject to inversion. That is to say, the curve was workable for a season, say a few weeks,

or even four months in one position, and then the system conformed to the same curve if inverted. The explanation of this singular and apparently irrational phenomenon was not found for a long while, although the fact that it existed could not be doubted. The mode or law of this inversion is yet a subject of study, and its great irregularity makes it difficult to thoroughly understand.

It was now seen that the result of massing all the observations on one period was to give back very small residuals, which expressed merely the excess of the strength or the energy of one system over the other. Two large inverse types may thus give exceedingly small residuals, if they are nearly equally balanced in power. The form of the curve at first obtained was also partially defective for the same reason, three minor crests being suppressed in the magnetic field. On applying the clue thus obtained to the temperatures of the northwestern districts of the United States the two types emerged unmistakably, and also a curve more precisely representing the normal solar field. Now on reviewing each period of the European magnetic field with this improved curve it was comparatively simple to separate all the observed vectors into two parts corresponding to the direct and the inverse types. Thus the residuals were greatly improved, the forms of the curves steadied, and in every sense the future of the problem greatly strengthened. The critical elements at the earth, the magnetic field and the meteorological temperatures and pressures in the northwest, all agreed in classification under the same double system, and in producing curves that are merely the inverse of one another.

It next became extremely important to discover some simple, rational cause for this peculiar inversion, so persistent for years and so universal on the earth. In

the magnetic field it is common simultaneously to all stations in the northern and the southern hemispheres, in whatsoever longitude. In the meteorological system the principal center of concentration is in the northwest of the American Continent, so far as explored; other centers of action will doubtless be detected. Supposing the seat of inversion to be in the solar action, it was proper to classify the sun-spot areas in two groups, keeping the northern and the southern hemispheres independent of each other, by massing these respectively on this period. The result is very gratifying, for they give back the same fundamental curve, the southern hemisphere corresponding to the direct type, and the northern to the inverse type. This fact may well be regarded as the keystone to our arch, as it gives stability to the entire structure of the research. We must conclude that the sun emits two types of magnetic energy, whose products, to some extent, are the coronal stream lines and the sun-spot system, and probably other phenomena on the sun; while on the earth is to be found the same periodic function displayed in the variations of the magnetic field, and the American meteorological system certainly, acting continuously through the curved lines of magnetic force; spasmodic action within the solar nucleus gives the auroral display, the magnetic storms and electric currents, and possibly other important effects.

On the sun the minor results are the proof that the solar nucleus rotates with very nearly the same motion as the visible equator; the center of the coronal belt is in latitude $\pm 55^\circ$; the sun spots drift anti-rotationally, and by comparison in this period all surface currents can be detected and analyzed in longitude as well as in latitude; the density of the sun must be greatly modified by reason of a distribution of matter into a nucleus and a distant en-

velope or photosphere. On the earth it has been shown that the permeable magnetic material is confined to a shell about 800 miles thick; that in consequence of this the external field divides into an everted system, accounting for the location and movement of the auroral belt, and an inverted system, in some way related to the energy of tropical hurricanes; that the lacking term needed to account for the spasmodic action of storm generation over our entire hemisphere is to be attributed to the solar field; that the storm tracks of the United States vary in latitude and the eastward drift of storms in longitude, also the temperature annual means and amplitudes with the solar field in the 11-year period; that the storms are formed in the northwest in a procession corresponding to the type prevailing, and that this order is inverted with the type; that the maximum of extra-tropical storms of America, as compared with Siberia, is due to the impression of this variable energy upon the atmosphere in North America; that the prevalence of storms and cold waves in winter is due to the increased action of the magnetic field at lower temperatures; that the glacial epochs may naturally be referred to the long period variations of the sun as respects its magnetic output; that the observed minute variations of terrestrial latitudes may be plausibly ascribed to the action of the stresses in the ether at the surface of the earth, due to the mechanical forces generated in the ether by the transmission of radiant energy.

It is evident that, besides the very practical results to forecasting to be expected from a complete solution of the problem of storm generation in this long period of 26.68 days, we have a large field of study in the relations of magnetism and electricity. If all radiant energy is accompanied by vector stresses in the ether, of the minute amount disclosed by the residuals, it may

not be impossible that gravitation is an ether stress generated by the atomic vibrations of ponderable matter, spreading in spherical waves through space, according to the Newtonian law. The fact that the sun's hemispheres exhibit the normal field inverted in them respectively, by which a maximum in one corresponds to a minimum in the other on the same meridian, leads one to doubt that a continuous line of force, as assumed in theory, passes from the positive to the negative pole. At any rate here is an exhibition of what a dynamic magnet is actually doing, our experiments heretofore having been confined to static conditions. The mode of transference of this magnetic energy through the ether is wholly unknown, and its solution must greatly enlighten us upon several important subjects.

This research has been greatly handicapped because no magnetic observations have ever been made in the northern Rocky Mountain regions of the United States, where the interrelation of several primary physical forces can be most successfully studied. The high altitude of this region, bringing the stratum of the atmosphere in which observations are made more nearly into contact with the external field, and its proximity to the polar magnetic cap, suggest that it is the most appropriate place for the establishment of a magnificent permanent solar-terrestrial observatory, equipped with the best instruments available, and managed by men of power in scientific investigations. One such observatory in the Northwest and another in the eastern part of the United States, together with some minor stations, would no doubt amply repay the American people for the expense of equipping and maintaining them through the agency of the Government.

FRANK H. BIGELOW.

WASHINGTON, D. C.

CURRENT NOTES ON PHYSIOGRAPHY (XVI).

RUSSELL'S LAKES OF NORTH AMERICA.*

PROFESSOR RUSSELL calls his new book 'a reading lesson for students of geography and geology.' It is appropriately dedicated to Gilbert. An opening chapter discusses the origin of lake basins, a subject which the author's own studies in the West have greatly advanced; for we owe to Russell not only the best account of a region of comparatively recent dislocations, where lakes lie in the relatively depressed areas, but also the description of such lacustrine curiosities as Moses Lake, in Washington, retained in a deep valley behind a barrier of sand dunes, and such as the two lakes that lie in basins formed by the plunge of a cataract on the temporary glacial course of the Columbia. Other chapters concern the movements of lake waters and the geological and climatic functions of lakes. The topography of lake shores is particularly well illustrated, chiefly by plates selected from publications of the U. S. Geological Survey, now placed more conveniently in the hands of teachers and students. The relations of lakes to climatic conditions, the resultant composition of their waters and the variation of their volume are fully considered. The book closes with an excellent account of certain special lacustral histories, including the pleistocene lakes of the Laurentian basin, Lake Agassiz, the pleistocene lakes of the Great Basin and certain lakes of the more remote past. If this book has the circulation that it deserves, the rising generation of geographers will greatly profit by it.

A SEICHE IN LAKE SUPERIOR.

A CLASS of movements of lake waters, briefly treated in Russell's book, is the 'seiche,' or slow oscillation of level, long

*Ginn & Co., Boston, 1895, 125 pages, with numerous illustrations. Price, \$1.65.

known and minutely studied in Switzerland, especially by Forel; vaguely recorded and hardly studied at all in this country. A strong seiche was observed in Chequamegon Bay, near the west end of Lake Superior, on September 11, last. It rose in a 'wall of water' about four feet high, extending across the bay and rushing in upon the low shore, where it did much damage, lifting up the logs of corduroy roads, breaking log booms and drifting the logs away, and even putting out the fires under a few steam boilers. The water gradually subsided, bearing back to the lake a confused flotsam of 'roots, grass, tree tops and other debris.' Mr. G. M. Burnham, of the Ashland (Wis.) *Daily Press*, calls my attention to the occurrence at Harbor Springs, near the north end of Lake Michigan, also on September 11, of a gradual depression of the water 'fully five feet,' followed by a gradual rise, and other minor changes of level. Although these peculiar disturbances are sometimes strong enough to break boats away from their moorings, and although the automatic records of water levels maintained by the army engineers at various lake ports show minor seiches of almost continual occurrence, no serious study of their varied phenomena has yet been undertaken.

BATHYMETRY OF THE ENGLISH LAKES.

DR. H. R. MILL describes his bathymetrical survey of the English lakes in the July and August numbers of the (London) *Geographical Journal*, with many illustrations from photographs and an excellent series of tinted maps by Bartholomew. The view of Wastwater is a particularly good illustration of a lake in its hill-setting; not simply a sheet of water bounded by a distant shore, such as appears in most pictures of lakes. The following table presents a number of the results gained:

| Lake. | Length. miles. | Area, sq. m. | Eleva- tion. | Depth. | |
|----------------------|-------------------|-----------------|-----------------|--------|-------|
| | | | | Max. | Mean. |
| Windermere. | 10.50 | 5.69 | 130 | 219 | 78½ |
| Ullswater. | 7.35 | 3.44 | 476 | 205 | 83 |
| Wastwater. | 3.00 | 1.12 | 200 | 258 | 134½ |
| Coniston Water. | 5.41 | 1.89 | 143 | 184 | 79 |
| Crummock Water. | 2.50 | 0.97 | 321 | 144 | 87½ |
| Emerdale Water. | 2.40 | 1.12 | 368 | 148 | 62 |
| Bassenthwaite. | 3.83 | 2.06 | 223 | 70 | 18 |
| Derwentwater. | 2.87 | 2.06 | 244 | 72 | 18 |
| Haweswater. | 2.33 | 0.54 | 694 | 103 | 39½ |
| Buttermere. | 1.26 | 0.36 | 329 | 91 | 54½ |

Derwentwater and Bassenthwaite belong together as a shallow lake, divided by an alluvial flat; their average depth being only 18 feet, and this average being only a quarter of their maximum depth. The other lakes form a deeper group, whose average depth is 40 feet, while the average depth of each one varies from 36 to 61 per cent. of its maximum depth. The best examples of this class lie in long narrow valleys with steeply sloping sides, the slopes being continued under water and terminating on a flat bottom. The lakes as a whole reach just as far as and no farther than the beginning of the more level country which skirts around the highland.

DIURNAL VARIATION OF RIVER VOLUME AND VELOCITY.

PROFESSOR BRÜCKNER, of Berne, contributes a review of numerous observations on the rivers of Switzerland to Petermann's *Mitteilungen* (June and July, 1895,) which result in showing that all the streams heading in regions of melting snow or ice have perceptible diurnal fluctuations in volume and velocity. These are noticeable in the Arve to the city of Geneva, the Rhone to its mouth in Lake Geneva, the Aar to Lake Brienz, the Reuss to Lake Lucerne, especially in midsummer; the wave of high water advances down stream at a rate of three or four meters a second. Side streams entering a trunk river at different points tend to confuse the high water wave, but

fail to obliterate it. While a particle of ice requires decidedly more than a century to move from the summit of the Jungfrau to the foot of the Aletsch glacier, 29 km., only twelve hours are needed for the water to flow from the glacier down the Rhone to Lake Geneva, where it remains on the average about eleven years before resuming its journey to the Mediterranean.

GEOGRAPHY IN NORMAL SCHOOLS.*

TEACHERS of geography in normal schools will do well to consider Mr. Murdock's plan of work at Bridgewater; not so much because it can be immediately applied elsewhere as because of the importance that it attaches to local observation in geographical study, and because of the large share of attention allowed to questions of origin, structure, denudation and the like, which are too often left to one side, as if fenced off in a geological field where the geographer must not trespass. Many references are made to good materials. On the other hand, the fault of too much method, thought by many educators to be characteristic of normal schools, occasionally appears; as in such a definition as "A picture of an object is the representation on a surface of the appearance of an object." Any scholar in a normal school who needs this definition cannot be ready for serious geographical study. So sententious a truism as "Geographical objects within the range of vision must be observed; the product of the observation is knowledge," is another sign of those normal school methods in which a diluted psychology is mixed with other subjects of study, to the distress and embarrassment of the everyday teacher.

W. M. DAVIS.

HARVARD UNIVERSITY.

* *Outline of Elementary Geography.* By F. F. Murdock, State Normal School, Bridgewater, Mass. Revised edition. July, 1895. pp. 159.

SCIENTIFIC NOTES AND NEWS.

THE IPSWICH MEETING OF THE BRITISH ASSOCIATION.

THE address of the president, Sir Douglas Galton, already printed in this journal, attempted the difficult task of reviewing the progress of science during the sixty years that have elapsed since the foundation of the Association. His long service as secretary made him especially familiar with those scientific advances to which the Association has directly or indirectly contributed. Prof. W. M. Hicks, president of Section A (physics), reviewed recent attempts to explain the ultimate nature of matter. Prof. Raphael Meldola, president of Section B (chemistry), reviewed the great progress made by the science since the previous Ipswich meeting in 1851. The address of Mr. W. Whitaker, president of Section C (geology), is reported in the present number of SCIENCE. Prof. W. A. Herdman, president of Section D (zoölogy), dealt almost entirely with questions of marine zoölogy. Mr. H. J. Mackinder, president of Section E (geography), and Mr. L. L. Price, president of Section F (economics), reviewed recent developments in their respective departments. Mr. L. F. Vernon-Harcourt discussed the relation of engineering to science with special reference to mathematics and chemistry. The address of Prof. Flinders Petrie, president of Section H (anthropology), on interference with lower civilizations has been widely quoted in the daily papers. In Section K (botany) the president, Mr. W. T. Thiselton-Dyer, gave an account of Henslow in his relations to Darwin, and compared the old natural history and the present laboratory methods in botany.

THE scientific papers presented before the several sections were numerous and interesting, but it is difficult to select any for

special notice. Lord Rayleigh, who the year before announced the discovery of argon, described minute investigations into the refractive indices and viscosities of argon and helium, and Professor Runge, of Hanover, communicated the results of experiments, showing that the gas from cleveite is made up of two constituents, of which one is always present in the sun, and the other only occasionally and proposed that the name helium should be restricted to the former. The interpretation of the results obtained with the spectroscope was discussed by Prof. Schuster and Dr. G. J. Stoney. Two of the most important papers presented before the Association, that on the 'Electrification of Air' by Lord Kelvin, Mr. Maclean and Mr. Galt, and that on 'Oysters and Typhoid' by Professors Boyce and Herdman have been contributed by the authors to this journal.

THE attendance at the Ipswich meeting was the smallest since 1880, the total number of members present being 1,234. This is, however, nearly double the number that attended a previous meeting held in this town in 1851, and bears witness to the increasing size and influence of the Association. According to the report of Professor Rücker, general treasurer, the receipts for 1894-95 were £4,214; £1,160 was appropriated by the committee for scientific purposes and distributed among the different sections as follows: Mathematics and Physics, £245; Chemistry, £80; Geology, £140; Zoölogy, £405; Geography, £10; Mechanical Science, £40; Anthropology, £180; Physiology, £25; for the report of the Corresponding Societies, £30. Sir Douglas Galton resigned the general secretaryship of the Association, a position which he has held for more than twenty-four years. Professor E. A. Schäfer was elected his successor. The next meeting of the Association will be held at Liverpool, commencing

on Wednesday, September 16, 1896, under the presidency of Sir Joseph Lister. Toronto was selected for the place of meeting in 1897. An invitation from Bournemouth has been received for the year 1898, and an invitation from Dublin is expected for the same year.

THE BROOKLYN INSTITUTE OF ARTS AND SCIENCES.

THE prospectus of the Brooklyn Academy of Arts and Sciences for 1895-96 has been recently issued. It gives preliminary announcements of the courses of instruction, lectures, exhibitions and entertainments planned for the ensuing year. A number of well known specialists from other institutions have been invited to lecture during the year, and many of these have already consented.

Six illustrated lectures in astronomy may be mentioned as of special interest. Mr. Percival Lowell has been invited to lecture on 'The Planet Mars,' Professor Henry A. Newton on 'Meteors,' Professor Edward E. Frost on 'Stellar Spectroscopy,' Professor James E. Keeler on 'The Methods of Astro-Physical Research with Special Reference to Saturn's Rings,' Mr. Wallace Gould Levison on 'Radiant Matter,' and Mr. John A. Brashear on 'The Evolution of a Telescope, or the Story of an Astronomical Object Glass.' In the department of Domestic Science Professor John S. Billings will lecture on 'The Diseases of Occupations,' and Professor R. H. Chittenden on 'The Value of Meats as Food.' The names of Mr. William Kent, Professor R. H. Thurston and Professor Frederick R. Hutton appear in the list of lecturers in the department of Engineering. The Geological department is particularly strong, lectures being announced on the first Monday evening of each month by President T. C. Mendenhall, Professor R. S. Woodward, Dr. Charles D. Walcott, Dr.

Joseph F. James, Professor Charles S. Prosser, Dr. W J McGee, Professor W. M. Davis and Professor D. S. Martin. Professor Woodward will also deliver a course of lectures in the Mathematical department. Professor William O. Crosby, Professor Samuel L. Penfield, Dr. W J McGee and Professor A. J. Moses are announced to lecture in the Mineralogical department. In psychology Professor William James will deliver a course of six lectures on 'Recent Researches into Exceptional Mental Phenomena,' and Professor G. T. Ladd a course of six lectures on hypnotism from the physiological and psychological points of view. It is hoped that Professor E. D. Cope and Professor E. B. Wilson will lecture in the Zoölogical department.

Further information concerning the Institute and the terms of membership may be obtained from the Director, Professor Franklin W. Hooper, 502 Fulton Street, Brooklyn.

GENERAL.

PROFESSOR RAMSAY writes to *Nature* that he has received a letter from Prof. Olszewski, of Krakau, in which he informs him that having exposed a sample of helium which he sent him to the same treatment as was successful in liquefying hydrogen—namely, compressing with a pressure of 140 atmospheres, cooling to the temperature of air boiling at low pressure, and then expanding suddenly—he has been unable to detect any sign of liquefaction. The density of helium being, roughly speaking, twice that of hydrogen, it is very striking that its liquefying point should lie below that of hydrogen. It may be remembered that argon, which has a higher density than oxygen, liquefies at a lower temperature than oxygen; and it was pointed out by Prof. Olszewski that this behavior was not improbably connected with its appar-

ently simple molecular constitution. The similar fact now recorded for helium may therefore be regarded as evidence of its simple molecular constitution.

THE directors of New York Botanic Garden, to be laid out at Bronx Park, have formally accepted the allotment of 250 acres in Bronx Park, with the restrictions relating to the cutting down of trees in Hemlock Grove, and voted to request the Park Department to secure from the city the \$500,000 appropriated in the act of incorporation in case \$250,000 was raised by private subscription. The entire \$250,000 has been subscribed in amounts of \$25,000, and a large part of the sum has already been paid in. The gardens are to be left so far as possible in their natural condition.

ACCORDING to the returns issued on the present state of cholera in Russia, there occurred during the last fortnight of September in the province of Podolia 51 cases and 19 deaths from the disease, and in the province of Volhynia 7,827 cases and 3,085 deaths.

THE Committee on Terrestrial Magnetism of the British Association presented at the Ipswich meeting an elaborate analysis of a series of observations made with the magnetographs at Kew Observatory by the recently appointed Director, Dr. Chree.

MACMILLAN & Co. have issued the first number of a quarterly journal, *The American Historical Review*. Six of the leading American historical scholars constitute a board of editors, and Professor J. Franklin Jameson, of Brown University, is managing editor. The number contains 208 large octavo pages, and maintains throughout a high standard of scientific scholarship.

MR. J. GRAY read a paper before Section H, of the British Association, upon anthropometric observations in East Aberdeenshire, which pointed to the existence in Aberdeenshire (1) of a Germanic or Can-

stadt type, fair-haired, with light eyes, concave nose, and an average height of 5 ft., 7 in.; (2) of an Iberian or Cro-Magnon type, dark-haired, dark-eyed, aquiline-nosed, and of an average height of 5 ft., 11½ in.; and (3) of a broad-headed type, dark-haired, dark-eyed, probably straight-nosed, with an average height of 5 ft., 4 in.

THE issue of the *British Medical Journal* for October 5th states that the lines inscribed on Huxley's tombstone, and quoted in the last number of SCIENCE, are part of a poem by Mrs. Huxley, and were used as Huxley's epitaph at his own request.

MR. W. J. L. WARTON states in *Nature* that a deeper spot in the ocean than any yet known has been recently found by H. M. surveying ship *Penguin*. Unfortunately the observation was not complete, as a fault in the wire caused it to break when 4,900 fathoms had run out without bottom having been reached. This occurred in lat. 23° 40' S., long. 175° 10' W., about 60 miles north of a sounding of 4,428 fathoms obtained by Captain Aldrich in 1888. As the deepest cast hitherto obtained is one of 4,655 fathoms near Japan, it is at any rate certain that the depths at the position named is at least 245 fathoms greater.

It is stated that Professor Joly has sold the right to his process of color photography for the United States and Canada to Mr. Schuyler, of New York, for \$30,000. He is negotiating for the sale of the right to the process for other countries, and the invention is patented for England.

THE third annual convention of the National Society of Electro-therapeutists met at Boston on Wednesday, the 17th and 18th of September, under the presidency of Dr. Wm. L. Jackson. In speaking of recent advances in the applications of electricity to therapeutics, the president said: "Already electricity has a wide sphere of usefulness. Even its physical properties, as heat and

light, assist us. By means of its light, we obtain a knowledge of internal organs and parts by which we are enabled to treat them far more satisfactorily than we could without its aid. It has been proved that the effect of the electric light on plants is to stimulate their growth and improve their condition. This being a fact, it is reasonable to suppose that it might have the same effect on animal life, and, indeed, recent experiments with the electric light bath upon the bodies of patients have shown this to be the case. It is in the diseases of the nervous system that it finds one of its most useful spheres of influence. Not only is it valuable in determining the site of disease, but it gives us most healthful aid in neuralgic affections and paralysis. Above all, it is one of the safest and best general tonics at our command."

THE jury of awards of the Atlanta Exposition, with President Gilman at the head, will assemble in Atlanta on October 15. Among the members of the jury are the following:

Gen. Henry L. Abbot, United States Engineers, 'Engineering, and Public Works.'

President C. K. Adams, of the University of Wisconsin, 'Liberal Arts.'

Prof. N. Murray Butler, of Columbia College, 'Education.'

G. Brown Goode, of the Smithsonian Institution, 'Fisheries.'

Morris K. Jesup, President of the American Museum of Natural History, New York, 'Museums, Parks, etc.'

President T. C. Mendenhall, of the Worcester Technical Institute, 'Machinery.'

Prof. Simon Newcomb, F. R. S., 'Instruments of Precision.'

Prof. Ira Remsen, Baltimore, 'Chemistry.'

Prof. Henry A. Rowland, F. R. S., Johns Hopkins University, 'Electricity.'

THE State Geological Survey of New York, according to the *Engineering and Mining Journal*, has been busily at work this summer. Prof. Charles W. Comstock, one of the professors of engineering at Cornell

University, who has done excellent work on the surveys in Colorado, is in charge of work on the upper Hudson district with numerous able assistants. Prof. C. Wellman Park, recently in charge of the department of physical science at the Rensselaer Polytechnic Institute, has charge of the survey work in Franklin county, with a large corps of men engaged in making surveys of large tracts of State land on township 24, etc., near the Saranac Lakes. Mr. Monroe Warner, recently a United States Deputy Surveyor for South Dakota, is at work with a party in townships 1 and 2 of Totten & Crossfield's purchase in the county of Hamilton, near Scandago Lake and Lake Pleasant. Mr. Solomon Lefevre, formerly an assistant on the New Jersey Geological Survey under Prof. Cook, is in charge of surveys in the district of the Indian River and West Canada Creek, Vrooman's patent, Herkimer county. Perhaps one of the most important results of the work accomplished of general interest will be some computations made by Prof. Olin H. Landreth, formerly of Vanderbilt University, Nashville, Tenn., now professor of mechanics and engineering at Union University.

MACMILLAN & Co. announce a translation, by Mr. A. J. Butler, of Professor Frederick Ratzel's *History of Mankind*, to be published in thirty monthly parts. There will be a preface by Professor E. B. Tylor and the work will be elaborately illustrated.

MR. E. H. GRIFFITHS opened a discussion at the recent meeting of the British Association on Heat Standards. He said the thermal capacity of water had been taken as a standard since the time of Black, but caused many inconveniences. The different heat units proposed were: (1) the specific change per degree centigrade of the product of pressure and volume of a gramme of hydrogen, by Macfarlane Gray; (2) the latent

heat of evaporation of a gramme of water at ordinary pressure, by Joly; (3) the latent heat of fusion of a gramme of ice, by Pickering. But none of these are simply related to other units, and they are arbitrary. He suggested a thermodynamic unit—namely, the heat energy of 42 million ergs. This is a natural and an absolute unit, independent of the researches of any observer, and convenient in magnitude. It may be interpreted practically as the amount of heat required to raise a gramme of water 1 deg. C. at 10 deg. C., as measured on a hydrogen thermometer.

UNIVERSITY AND EDUCATIONAL NEWS.

THE buildings of the University of the City of New York at University Heights will be formally opened on Saturday, October 19th. The two buildings that will be dedicated are the Hall of Languages and the Havemeyer Laboratory. The new gymnasium is also finished and will be open for inspection. Dr. Anson Judd Upton, Chancellor of the University of the State of New York, will make an address and speeches are expected from Governor Morton, Mayor Strong, Dr. Wm. T. Harris, President Hill of Rochester and President Gates of Amherst. Part of the dedicatory exercises will be the breaking of ground for the new library building.

THE Freshman class in the academic department of Yale University numbers 330, one less than last year. The Freshman class in the scientific department numbers 149, a decrease of 101 as compared with last year. This decrease is attributed to changes in requirements of admission. There are this year 149 graduate students, as compared with 138 in 1894 and 143 in 1893. The number of professors and instructors is this year 227, an increase of 20. The professorships of natural philosophy and astronomy and of botany have not been filled.

By the will of Col. W. L. Chase \$5,000 is bequeathed to the president and fellows of Harvard College to establish a scholarship in the medical school, to be known as the Charles B. Porter scholarship.

DR. FREDERICK F. DUNLAP, a graduate of the University of Michigan, has been called to an assistant professorship of organic chemistry in Yale University.

At the Ohio Wesleyan University, Professor Albert Mann, Ph. D., who has recently returned from Munich, has entered upon his new field of labor in the biological department. The enrollment of students in this department is twice as great as during any preceding year in the history of the College. Professor Trumbull G. Duvall, Ph. D., has just resigned the chair of philosophy at DePauw University, in order to take charge of the department of philosophy. Mr. Duvall is establishing a fine departmental library in connection with his philosophical instruction at the University. Lieut. Waldo E. Ayer, of the 12th U. S. Infantry, has been detailed by Secretary Lamont as professor of military science and tactics. Prof. Ayer will report at the University for duty immediately.

MR. DANIEL T. MACDOUGAL has lately been appointed assistant professor of botany in the University of Minnesota. He will have charge of the graduate and undergraduate courses in plant physiology. Miss Josephine E. Tilden has been awarded the Albert Howard Fellowship on the basis of her work on American fresh-water algae.

A NEW \$40,000 laboratory building is about completed for the departments of bacteriology, histology and pharmacy in the medical college of the University of Minnesota.

THE recently published 'Directory of the Officers and Students of Brown University' shows a total enrollment of 844 students, an increase of 104 over that of last year.

THE number of students in the school of biology of the University of Pennsylvania has greatly increased. More than 300 students are taking the biological courses, about one-third of these being women.

THE Spring Garden Institute of Philadelphia has received a gift of \$100,000 from the heirs of Samuel Jeanes, who supported the Institute with great generosity during his lifetime.

M. H. WHITE, of Cincinnati, and his brother, F. T. White, of New York, have given \$25,000 to Earlham College at Richmond, Ind., in memory of their father, the late John T. White. The College is supported by the Society of Friends.

DR. A. H. THORNDIKE has been appointed instructor in mathematics in Boston University.

DR. G. P. GRIMSLEY, of Topeka, Kansas, has accepted the professorship of geology and natural history in Washburn College.

LAFAYETTE COLLEGE will hold a celebration on October 24th in honor of Professor Francis A. March, the distinguished philologist, who this fall completes his seventieth year and forty years of service in the College. The exercises will begin at 11 a. m., in the auditorium of Pardee Hall, ex-President W. C. Cattell presiding, and will consist of an address by Professor W. B. Owen on Dr. March and his work for Lafayette, and several addresses by Dr. March's fellow laborers in the field of English language and philology; Dr. Wm. T. Harris, U. S. Commissioner of Education; Professor T. R. Lounsbury, of Yale; Professor J. W. Bright, of Johns Hopkins, and Professor Thos. R. Price, of Columbia.

LEHIGH UNIVERSITY celebrated Founder's Day on Thursday, October 10th. An address was delivered in the Packer Memorial church by the President, Dr. Thomas M. Drown.

THE Council of University College, Dundee, has appointed to the new Harris chair of physics Dr. J. P. Kuenen, Ph. D., of the University of Leyden, Holland.

MR. GEORGE SAINTSBURY has been appointed professor of rhetoric and English literature in the University of Edinburgh.

DR. W. BIEDERMANN, professor of physiology at Jena, has received a call to the University at Graz. Dr. Adolf Heydweiller, of Strassburg, has been made assistant professor of physics in the University of Breslau.

DR. OTTO JAEKEL has been promoted to be a professor of paleontology at Berlin.

CORRESPONDENCE.

PROFESSOR BROOKS ON CONSCIOUSNESS AND VOLITION.

IN SCIENCE of October 4th Professor Brooks has a letter on two communications in previous numbers by Professor Gage, of Cornell University, and myself, in which he expresses objections to them. It is necessary that I state the names of the authors of these articles, as Professor Brooks unaccountably does not do so.

Professor Brooks' objection is to a supposed assumption of knowledge on the part of these persons which he is sure that they do not possess, and he is willing to characterize their assumption by no worse a term than 'poetry.' In any case, he says, it is not science. His objections extend not only to the papers criticised, but to the societies which are supposed to have endorsed such views by electing one of their authors 'many times president;' they will logically extend also to the societies who have elected the other one president, though Professor Brooks does not refer to them.

Professor Brooks' specific objection is to the assumption that "consciousness and volition can cause structure or anything else." He also varies the proposition thus: "If we admit, as I think we must, that for all we know an oak tree may have volition and may do as it likes, what evidence is there that it ever likes to do anything which it would not do in any case by

virtue of its structure even if it were unconscious."

I have much respect for Professor Brooks' abilities and work as a biologist, but in the above sentences he commits the common error of confounding volition with consciousness in a way which will surprise any student of mental phenomena. I am not aware that any well-read person in modern times has proposed the hypothesis that 'volition,' or doing 'as it likes,' is a property of the vast majority of protoplasm, while every naturalist knows that consciousness is a property of protoplasm, though not of all protoplasm so far as our means of observation permit us to judge. Students of cells and tissues are very frequently not students of consciousness, and I will therefore add another commonplace of psychology, and that is that the responses of conscious protoplasm to stimuli are as strictly regulated by necessity as the responses of unconscious protoplasm, though the necessity is of a different kind.

The proposition that a muscular contraction is influenced, *i. e.*, directed by a conscious state, may be a matter of mere opinion, or it may be a working hypothesis, or it may represent a fact. Mankind generally, including many scientific men, hold it to be a fact. Lord Kelvin, according to Prof. Gage, is of this number, though he calls it a 'miracle.' However, Prof. Brooks will probably allow that it is a permissible working hypothesis, although he does not say so directly. If we grant that it is true of man, which most of us do, no one has yet shown where the line is to be drawn, as we descend the scale of animal life, at which sensation ends. In fact, centers of special sense are alleged to exist in many Protozoa, and if special sensation exists it is probable that general sensation exists still lower down in the scale.

As to whether such sensation, if it exists, has any effect on structure, the reasons for thinking that this occurs through the medium of movements have been stated so often that it is not necessary to repeat them here. I only refer for a resumé of some of the evidence to a book by myself which will probably be issued by the Open Court Publishing Co. by the beginning of next month.

A common source of obscure thinking among

naturalists is the assumption that reflex and automatic acts disprove the agency of conscious states in the direction of movements. Evolutionists, however, look for the origin of things, and some of them find consciousness, as a cause of the direction of new movements now, to be an equally supposable cause of new movements at former periods of the earth's history. Here we have again a legitimate working hypothesis; although it is not necessary to account for all the movements of organic matter.

Of course, the opposing view to the hypotheses above mentioned involves the assumption of their falsity. To give the opposite position the standing in court adopted by Professor Brooks, I quote him with variations, as follows: "If the learned bodies which give their allegiance to the utterances I have quoted will publish the evidence that consciousness and volition can influence Professor Brooks when he writes a learned article, or makes an address on a biological subject, 'they will not only demonstrate their own scientific eminence, but by settling a question which has never ceased to vex the mind of man they will make the closing years of the nineteenth century memorable for all time,' etc. Thinkers will adopt one or the other of these hypotheses as they see fit, but when they touch the metaphysical side of the question they must give to it that attention which it deserves.

Professor Brooks' plea for suspense of judgment is wise. But the formulation of a hypothesis need not alarm him. Builders generally know the difference between the scaffolding and the building. And a builder will value the indication of faults in his scaffolding rather than general disquisitions on the uselessness of scaffolds in general.

E. D. COPE.

P. S. I hope to make shortly some comments in the pages of the American Naturalist on previous articles in SCIENCE by Profs. Baldwin and Cattell.

ABSORPTION OF TERRESTRIAL RADIATIONS BY THE ATMOSPHERE.

I AM certainly glad that Prof. Davis (SCIENCE p. 485, Oct. 11, 1895) objected to the extreme terms which I used in referring to the blanket effect of our atmosphere. I object to them

myself, and must have used them in a moment of mental aberration. I should have said that the bolometer had given us most of the reliable data concerning the absorption and transmission of radiant energy by the atmosphere, although at that time I fully believed, both from a general knowledge of Prof. Langley's work, and from conversations with him, that the atmosphere was a pretty good valve. Prof. Davis's references and a recent study of the published data show that the valve is leaky indeed. Still, if the atmosphere absorbs 50% of the Sun's radiations, and 50% of those from the earth, we have 25% of the Sun's radiations let in and not let out. If we take the figures which I believe Langley recommends, 70% for the solar, and 40% for the terrestrial radiations, we should have a catch of 40% of that originally arriving from the Sun.

Many unexplained points concerning this complex problem continually appear. What becomes of the 30-40% of the solar radiations and the 40% of terrestrial radiations absorbed by the atmosphere? It has but little mass and low specific heat, and yet it does not get hot, except in its lower layers. This source of energy it seems to me would be more than sufficient for all meteorological phenomena. Prof. Langley's data, voluminous and wonderful as they are, still appear incomplete in certain very important directions, leaving a very attractive field for investigation.

As to terminology, it seems to me very convenient to speak of 'heat rays' so long as we know exactly what we mean by the expression. We are all familiar with 'light rays,' and a 'heat ray' is the same thing, only, as Maxwell says, considered in its 'thermal aspect.' The term 'ray' is no doubt bad, but it is convenient and should be permissible with a tacit understanding that it is only a makeshift term. It would, of course, be better if we had some term to signify energy in its radiant form, as to direction of propagation, wave front, etc., but so long as we have not, and inasmuch as we all recognize its identity, why not use the old names and avoid multiplication of words. Even Prof. Langley's 'Luminous heat' ought to mislead no one; evidently he refers to the heat effects of that kind of radiant energy which is also capable of

producing light effects; 'dark heat rays' are incapable of so doing. When Professor Langley speaks of the 'radically different character of the heat in two maxima' he refers, of course, to their different wave-lengths. A similar remark about a treble and bass note would not mislead any one into the idea that both were not sound. I fail to see what is wrong with the last quotation from my article, or exactly what is meant by the 'mis-recognition of the early part of this century.'

I sympathize most sincerely with Professor Davis in his demand for precise terminology, but we must not allow even this worthy desire to lead us into complexities of expression which may be even more fatal to perspicuity than old terms with modern significations.

W. HALLOCK.

COLUMBIA COLLEGE, October 11, 1895.

A REPLY.

EDITOR OF SCIENCE: If it be fair to presume, as does Dr. Emory McClintock on page 453-4 of SCIENCE, under a heading which I think should be 'Professor Halsted Corroborated,' that because neither in a private letter nor in print one specifies his many mistakes, therefore one did not disapprove both his 'half on Saccheri as well as the half on Gauss,' then I must beg of SCIENCE a line to say that among other mistakes in this letter of his, he is completely wrong in saying of me: "He found that the two words *diuturnum prælium* were meant by Saccheri to indicate a mental attitude of constant war against the 'hypothesis' as heretical."

GEORGE BRUCE HALSTED.

AUSTIN, TEXAS, October 7, 1895.

THE RUDOLF LEUCKART CELEBRATION.

SEVERAL months ago the following circular (Cf. SCIENCE, Vol. I., p. 187) was sent out from Leipzig, signed by about a hundred and fifty scientists from various parts of the world:

"Zur Feier des am 13 December, 1895, stattfindenden fünfzigjährigen Doctorjubiläums von Rudolf Leuckart, dem Nestor unter den deutschen Zoologen, dessen Wirken weit über den Kreis seiner Specialwissenschaft hinausreicht, fordern die ergebenst Unterzeichneten zu Beiträgen auf. Im Herzen seiner zahlreichen

Verehrer steht es fest, dass der seltene Tag nicht vorbei gehen darf ohne ein dauerndes Zeichen der Erinnerung. Wir gedenken von einem hervorragenden Bildhauer 'Leuckart's Marmorbüste' herstellen zu lassen und sie zugleich mit einer künstlerisch ausgestatteten Adresse zu überreichen.

"Wir wenden uns an alle, welche in ihrem geistigen Entwicklungsgange sein Wirken und seinen Einfluss verspürt haben, dass sie zu einer würdigen Ehrung des Jubilars beisteuern.

"Da es unmöglich ist, die Adressen aller seiner Schüler, namentlich derer, die nicht Zoologen von Fach geblieben sind, zu erlangen, so bitten wir diejenigen Herren, welche der allgemeinen Anregungen, die sie aus Leuckart's Vorlesungen in ihren Beruf mit hinausgenommen haben, in Dankbarkeit gedenken, dass sie in ihren Kreisen durch Verbreitung dieses Aufrufs in unserem Sinne thätig sind.

"Beträge werden erbeten an Herrn Carl Graubner (C. F. Winter's Verlag, Leipzig, Johannesgasse 8), welcher das Amt des Schatzmeisters freundlichst übernommen hat."

Within a few weeks of the receipt of the circular by American zoölogists I received a number of inquiries from various sources asking for further information regarding the subject, but was unable to reply to these inquiries, as I had not learned the detailed plans of the Leipzig Committee. At present, however, I can furnish some of the desired information, and, as the time is very short, will utilize the columns of SCIENCE for this purpose.

It is the intention of the Leipzig Committee to have a life-size marble bust of the Geheimrath made and to present it to him on December 13th, and it is understood that the bust will eventually be deposited in the University at Leipzig or in the Leipzig Gallery. The statue will be made by one of the most prominent sculptors of Germany, who attended Leuckart's lectures this last semester, unbeknown to the lecturer, in order to study his expression. The estimated cost is 4,000 marks, of which about 1,000 marks had been subscribed before September 1st. Should more money be collected than is necessary it will probably be spent for photographs of the bust which will be sent to persons who have forwarded subscriptions.

The subscriptions thus far made vary from 10 to 200 marks, most of them being in sums of 20 to 50 marks.

It is not intended to confine the subscriptions to Leuckart's pupils, for a number of other persons have expressed their desire to contribute. The Leipzig Committee therefore extends a cordial invitation to all admirers of the Geheimrath to join in the celebration, and I would therefore urge all of Leuckart's pupils in this country to bring this circular to the attention of their scientific and medical friends.

Subscriptions can be sent to Carl Graubner, as announced in the original circular, or to me. At the request of Dr. Simroth, the moving spirit in the undertaking, I have agreed to receive American subscriptions and forward the same in one sum to Leipzig.

CH. WARDELL STILES.

U. S. DEPARTMENT OF AGRICULTURE,
WASHINGTON, D. C.

TO THOSE INTERESTED IN QUATERNIONS AND ALLIED SYSTEMS OF MATHEMATICS.

DEAR SIRS: The mathematical ideas associated with the direct treatment of vectors and vector functions are daily becoming more familiar to the scientific mind. Half a century ago the broad principles of vector theory were laid down in the Quaternions of Hamilton and the Ausdehnungslehre of Grassmann. In his second monumental work Hamilton developed a vector calculus of great power and flexibility, peculiarly appropriate to geometry and physics; while both systems, in their richness of transformations, generality of treatment, simplicity of expression and interpretation, surpass any other known forms of mathematics. Nevertheless, these systems have not received the attention that is surely their due, and remain still in a comparatively undeveloped state.

Meanwhile, in connection chiefly with the remarkable advance in electrical theory, the growing necessity for a vector calculus, or at least for a compact vector notation, has induced more recent investigators to invent new systems, which have very much in common with those already established by Hamilton and Grassmann.

The time, therefore, seems to be ripe for a combination of forces, so that workers in these important lines may become known to one another, and the enthusiasm of students excited and sustained.

Led by these considerations we venture to suggest the organization of what we provisionally call 'the International Association for promoting the Study of Quaternions and allied systems of Mathematics.' By such an organization vector analysis would receive a great impetus. A journal published from time to time would keep the members of the Association in touch with the various aspects of the subject, both pure and applied, and would facilitate interchange of opinions on the introduction and adoption of new notations.

In these few lines we have tried to point out the important task of the Association, but shall be obliged for any suggestion or improvement. It is almost needless to say that we are only preparing the way; and once the Association has been started we shall be ready to place it in the hands of persons much more competent than ourselves to further its best interests.

We earnestly hope that all friends will appreciate our endeavors and show us at once some token of approval.

We remain, Dear Sirs,

Very respectfully yours,

P. MOLENBROEK, the Hague, Holland.

S. KIMURA, Yale University, U. S. A.

October, 1895.

N. B.—We would ask those who are in Europe to communicate with the first of the above names, and those in America with the second.

SCIENTIFIC LITERATURE.

Proceedings of the International Electrical Congress, Chicago, 1893. American Institute of Electrical Engineers. Edited by Max Osterberg.

The publication of this volume of nearly 500 pages insures a permanent record of the Chicago Electrical Congress and gives evidence of the value and importance of its work. The Congress was unique in its composition, since it consisted of both an official and an unofficial body. The 'Chamber of Delegates' was a small body represent-

ing ten governments and composed only of those presenting duly authenticated official credentials.

It may be said in this connection that while the expenses of the official representatives of foreign governments were paid, as far as known to the writer, our own government went only so far as to appoint representatives through its Secretary of State, but neither paid expenses nor, what is of much more importance, provided in any way for the meeting of this body of officially delegated scientific men from abroad, and took no official notice of them. This neglect was a source of great chagrin to the representatives of the United States. It would be impossible in Europe, with the sentiment prevailing there respecting the official etiquette befitting such an occasion.

The papers printed in this volume constitute a valuable collection of great variety, and no one interested in the higher phases of electrical theory and practice can afford to be without them. It is gratifying to know that the sales of the 'Proceedings' have already nearly or quite met the cost of publication, while a goodly number of volumes remain in the possession of the Institute.

An omission of some importance, in view of subsequent controversies, occurs in the report of the 'Proceedings of the Chamber of Delegates.' I refer to the appointment of the committee on notation and nomenclature. The presentation of the committee's report is noted, but one looks in vain for the names of the gentlemen composing it.

Inasmuch as a committee was appointed to draw up specifications for the Clark cell, consisting of Messrs. Helmholtz, Ayrton and Carhart, it may not be amiss to explain here why this committee never reported.* The chairman, Professor von Helmholtz, it will be remembered, was seriously injured on his return trip to Europe, and this unfortunate accident delayed action. The writer, however, received finally a long official communication from him in relation to the Clark cell and the legalization of the units adopted by the Congress. The proposals of von Helmholtz were accepted by myself with some slight modifications. Some correspond-

* *Proceedings*, p. 20.

ence was also had with Professor Ayrton, which served to clear up points of uncertainty. The committee of the British Board of Trade, however, preferred to adhere to the test-tube form of cell and proceeded to secure the legalization of their own specification without reference to the finding of the international committee. The work had all been done by the committee before the death of von Helmholtz, except the drawing up of a formal report. Upon the appointment of the committee of the National Academy of Sciences, all the information in the hands of the writer and the conclusions reached by the majority of the international committee were communicated to the chairman of the new committee, and they are embodied in his report (see *Mis. Doc. No. 115, 53d Congress, Senate*). I take pleasure in adding that the specification relating to the Clark cell, which was reported to Congress by the Academy committee, meets my entire approval and has some points of superiority over that legalized by the English 'Order in Council.' It is not likely, however, that any discrepancies between the E. M. F.'s of the two will be found to exist.

It seems necessary to add that the volume now under review is somewhat seriously marred by many typographical and other errors. The proof should certainly have been read by more than one person and by some one familiar with the details of the Congress.

HENRY S. CARHART.

The Alps from End to End. BY SIR WILLIAM MARTIN CONWAY. Westminster, Constable. New York, Macmillan & Co. 1895.

Sir William M. Conway, who has gained distinction among explorers of high mountains by his expedition to the Himalayas, made a rapid scramble over the Alps from end to end in the summer of 1894, and now presents a simple narrative of his excursion in a rather large book of four hundred pages with a hundred full-page plates; the latter being notable for the high average elevation of the points of view. Having taken Swiss guides to aid him in the Himalayas, Conway now brings two Gurkhas—natives of Nepal—to go with him over the Alps, at the same time advancing their mountaineering education, and thus enabling them better to

assist in Himalayan exploration on their return to the East. The use of a compass, an aneroid and a good contour map to find the way in the clouds is ingenious and worth learning. There is extremely little physiographical or geological matter in the book, but it abounds with the minutiae of personal incidents. For example, opening the book at random, we read: "On calling for provisions we found that the men had devoured all the fresh meat at breakfast, and that the day was to be a bread-and-butter one. Fitzgerald and I purloined the end of a sausage in revenge. It was easily secreted, but the straits to which we were put to eat it secretly," etc., etc. Of a day opening with rain it is frankly recorded: "We were delighted to hear that the morning was one for bed rather than mountains;" the glory of trips at headlong speed being apparently in having done them rather than in the doing. The book records a redoubtable athletic experience, but almost any one might write a volume if such shadowy substance is worthy of permanent record in large pages with open type. The only chapter of scientific value is on Mountain Falls; this being based chiefly on the account by Buss and Heim of the landslide of Elm, Canton Glarus, in 1881. W. M. D.

A Handbook for Surveyors. By MANSFIELD MERRIMAN and JOHN P. BROOKS, of Lehigh University. New York, J. Wiley & Sons, 1895. 16 mo., pp. 242.

This little book is at once text-book and field reference book for students and for surveyors in the field. It contains, in compact and systematic form, the information, the principles and the methods of surveying, so far as required in advance of the subject of railroad location—those of land and town surveying, leveling, triangulation and topography. It is given the pocket-book form in order that it may be conveniently used in the field, where its tables are likely to be at any moment useful, and where reference to the text-book is sometimes found advisable by the old practitioner as well as by the student and novice. Special attention is given to the testing of instruments and their comparison, and standard methods with some excellent new processes are described with the

lucidity and accuracy characteristic of these writers. A dozen tables are appended, the natural functions being given to five, and the logarithms and functions to six places of decimals. The book seems likely to prove very useful to a large class of engineers and surveyors and should find ready and extensive sale.

SCIENTIFIC JOURNALS.

THE MONIST, OCTOBER.

AFTER a careful examination of Darwin's own statements upon the matter, and a brief survey of the theories of Wallace, Weismann, Cope and the Neo-Lamarckians, Geddes, Henslow and others, the late Professor G. J. Romanes concludes, in the leading article of this number, on *The Darwinism of Darwin and of the Post-Darwinian Schools*, that Darwin's answer to the question whether the so-called Lamarckian factors were involved in the progressive modification of living forms was distinct and unequivocal, and that he never maintained that natural selection was to be regarded as the *sole* cause of organic evolution. As the mean between the two extremes of American Neo-Lamarckism and European Weismannism, Prof. Romanes believes that Darwin's judgment with respect to the relative importance of the factors of evolution will eventually prove the most accurate of all. Romanes' criticism of the American Neo-Lamarckians is that they do not distinguish between the 'statement of facts in terms of a proposition and an explanation of them in terms of causality,' but the bulk of the article is devoted to demolishing the erroneous and widely current impression implied in the so-called 'pure Darwinism' of Mr. Wallace, and especially to refuting the latter's conception of the intervention of a distinct individual intelligence in evolution.

Dr. Paul Topinard, in the second article, *Man as an Animal*, seeks to assign man's place in nature by a review of the results of anthropology, which for him is a branch of natural history pure and simple. His general conclusion is that man is not a creature apart in creation, but an animal like all the rest, only adapted and perfected to intellectual life; and

that from this point of view his interests and impulses are all individual and egotistic. In details his views are opposed to prominent American theories on this subject.

In *Criminal Anthropology Applied to Pedagogy*, Prof. C. Lombroso shows how the conclusions of criminology can be turned to practical account by teachers in their treatment of children. His article indicates more clearly than most of his writings do what are the limitations of his doctrine of the criminal type.

By *Arrested Mentation* (fourth article) G. Ferrero understands that law of natural logic by which the person of average power and education stops short in his reasonings at facts and phenomena falling under the notice of the senses, never pushing his inquiries after causes beyond the *obtrusive* facts of his experience. He also includes under this term our penchant for syllogistic reasoning, as opposed to the laborious and repellent methods of inductive research, and gives well-known historical examples in illustration of his idea.

The three last articles form a logically coherent group on the moral and religious upshot of scientific inquiry. That on *Naturalism* by Professor C. Lloyd Morgan is a defense of science against the recent animadversions of Mr. Balfour, and finds that Mr. Balfour's onslaught is directed against a wholly imaginary conception of the naturalistic tenets, and one which is never held by the foremost representatives of scientific thought. Dr. Paul Carus in *The New Orthodoxy* makes a plea for that 'rightness of opinion' which proceeds from the rigorous observation of the *objective* criteria of truth established by science. In *The Fifth Gospel* Dr. Woods Hutchinson, of the University of Iowa, announces a new evangel—the Gospel according to Darwin—which, the author claims, places morals and religion on firmer foundations than ever before.

Prof. F. Jodl reviews the philosophical publications of Germany and Austria, M. Lucien Arréat those of France, and Theodore Stanton writes on some French opinions of the Chicago Congresses. Emilia Digby discusses Prof. Le Conte's view of 'social evolution through the ethical law.' Numerous book reviews. Contents of Periodicals.

THE JOURNAL OF COMPARATIVE NEUROLOGY,
JULY.

The Mammalian Cerebellum. Part I. The Development of the Cerebellum in Man and the Cat: By BERT BRENETTE STROUD. This paper is introduced by sections on technique and terminology; also by an historical review. The development of the cerebellum of both man and the cat is presented in a series of drawings and descriptions of all of the important stages. In 1891 Herrick gave a brief description of the development of the cerebellum of the mammal and reptile, in which he showed that this organ arises not from a median anlage, but from two lateral centers of proliferation from which the neuroblastic elements migrate dorsad and mesad. In 1894 Schaper verified and amplified these observations in the teleosts. Mr. Stroud has fully illustrated the process in his two types, and has then traced the development of each of the major divisions of the adult organ. His paper is accompanied by eight plates and a bibliography.

Notes on Child Experiences: By C. L. HERRICK. I. Anthropomorphization of Numerals. The strong tendency of children toward personification has led in the case cited to a phenomenon not unlike pseudochromæsthesia. The boy of ten years habitually personifies and visualizes his numerals and attributes to each a moral nature in keeping with his form. II. Hallucinations of Vision in Children. In the course of a description of certain unusually vivid visual hallucinations which the author experienced in his own childhood, he takes occasion to criticize the recent statistical studies of the power of visualization. The average untrained observer is unable to tell whether he truly visualizes or not, so that much of the work done on the basis of recent statistics is fallacious.

The Cerebral Fissures of two Philosophers, Chauncey Wright and James Edward Oliver: By BURT G. WILDER. A brief comparison of the fissural patterns of these brains shows, in both, the frontal region unusually high and wide and the supertemporal fissure larger than common; but the very exceptional features of Wright's cerebrum are not repeated in Oliver's. But all

estimates of the extent and significance of their peculiarities will be only provisional until the careful comparison of many average brains supplies one or more types or standards.

Formula for the Preservation of Brains. [Preliminary Note]: By PIERRE A. FISH. A minimum shrinkage and loss in weight, cheapness and rapidity of action are the advantages claimed for the mixture proposed.

The Physiological Condition of Consciousness: By DR. PAUL CARUS. This article was called out by Professor Herrick's reply to Dr. Carus' article in the *Journal of Comparative Neurology* for September, 1894. Dr. Carus defends his use of the words 'feeling' and 'intelligence,' and reviews his arguments for regarding the corpus striatum as the seat of consciousness in the sense of an organ by which through some kind of a mechanical arrangement the connection between the memory-images are established so as to produce by their interaction the condition of consciousness. A bibliography accompanies the paper.

SOCIETIES AND ACADEMIES.

NEW YORK ACADEMY OF SCIENCES.

The first regular meeting of the year 1895-96 was held on Monday evening, October 7. No formal program had been announced beyond regular business, but after this had been transacted, the members present gave personal sketches of the work of the summer, and touched particularly on the meetings of the American Association, its affiliated societies and the British Association.

A proposed plan for the meeting of the British Association in joint session with the American Association at San Francisco in 1897 was brought up and informally discussed, but no action was taken.

J. F. KEMP,
Secretary.

THE TEXAS ACADEMY OF SCIENCE.

A REGULAR meeting of the Academy was held on the evening of Friday, October 4, at which the annual address by the President, Dr. George Bruce Halsted, was given, the subject being 'The Culture Given by Science.'

SCIENCE

NEW SERIES.
VOL. II. No. 43.

FRIDAY, OCTOBER 25, 1895.

SINGLE COPIES, 15 CTS.
ANNUAL SUBSCRIPTION, \$5.00.

GUSTAV E. STECHERT'S

Recent Importation of Scientific Books.

ADICKES, DR. ERICH. Kant-Studien. 185 Seiten. gr. 8^o. Mk. 4⁰⁰.

BENEDIKT, DR. MOR. Die Seelenkunde des Menschen als reine Erfahrungswissenschaft. 372 Seiten. 8^o. Mk. 6⁰⁰.

BERMBACH, DR. W. Der elektrische Strom und seine wichtigsten Anwendungen in gemeinverständlicher Darstellung. Mit 90 Abbildungen. 108 Seiten. 8^o. Mk. 2⁵⁰.

BIEDERMANN, W. Elektrophysiologie. 1^{te} Abtheilung. Mit 136 Abbildungen. 440 Seiten. 8^o. Mk. 9.

BOEGLE, DR. C. Die Entstehung organischer Formen. 18 Seiten. 8^o. Mk. 1²⁰.

CAPITAINE, EMIL. Das Wesen des Erfindens. Eine Erklärung der schöpferischen Geistesthätigkeit an Beispielen planmäßiger Anstellung u. Lösung erdinnerlicher Aufgaben. 135 Seiten. 8^o. Mk. 3⁰⁰.

DELAGE, YVES. La structure du protoplasma et les théories sur l'hérédité et les grands problèmes de la biologie générale. 878 pages. gr. 8^o cloth. frs 24⁰⁰.

DÜHRING, DR. E. Wirklichkeitsphilosophie, Phantasmenfreie Naturergründung und gerecht freieiliche Lebensordnung. 554 Seiten. 8^o. Mk. 9⁰⁰.

FOREL, DR. AUGUST. Der Hypnotismus, seine psycho-physiologische medicinische, strafrechtliche Bedeutung und seine Handhabung. 3^{te} verb. Aufl. mit Adnotationen von Dr. O. Vogt. 223 Seiten. gr. 8^o. Mk. 5.

FRICKS, DR. J. Physikalische Technik speciell Anleitung zur Ausführung physikalischer Demonstrationen und zur Herstellung von physikalischen Demonstrations-Apparaten mit mögl. einfachen Mitteln. 6^{te} ungerarb. und verm. Aufl. von Dr. Otto Lehmann. II. Band. Illustriert. 1054 Seiten. gr. 8^o. Mk. 20⁰⁰.

GRIESBACH, PROF. DR. H. Physicalisch-Chemische Propädeutik unter besonderer Berücksichtigung der medicin. Wissenschaften u. mit histor. und biographischen Angaben. 1^{ste} Hälfte. Bogen 1-17 mit Figur 1-44. gr. 8^o. Mk. 5⁰⁰.

HAACKE, DR. WILH. Die Schöpfung des Menschen und seiner Ideale. Ein Versuch zur Versöhnung zwischen Religion und Wissenschaft. Mit 62 Abbildungen im Text. 457 Seiten. gr. 8^o. Mk. 1⁵⁰.

HAMPE, DR. JULIUS. Ueber Geisteskrankheiten in Folge Schwefelkohlenstoff-Vergiftung. 51 Seiten. 8^o. Mk. 1⁰⁰.

HANSEN, DR. EMIL CHR. Untersuchungen aus der Praxis der Gährungsindustrie. Beiträge zur Lebensgeschichte der Mikroorganismen. 3^{te} verm. u. neubearb. Aufl. mit 19 Abbildgn. Heft I, 92 Seiten. gr. 8^o. Mk. 3⁵⁰.

HALLIER, DR. ERNST. Die Pestkrankheiten (Infektionskrankheiten) der Kulturgewächse. Nach streng bakteriologischer Methode untersucht und in völliger Uebereinstimmung mit Robert Koch's Entdeckungen geschildert. Mit 7 Tafeln. 144 Seiten. Text. gr. 8^o. Mk. 8⁰⁰.

HITZIG, DR. ED. Ueber den Quäralantenwahnsinn, seine nosologische Stellung und seine forensische Bedeutung. Eine Abhandlung für Aerzte und Juristen. 146 Seiten. gr. 8^o. Mk. 5⁰⁰.

JAHN, HANS. Grundriss der Electrochemie. 311 Seiten. gr. 8^o. Mk. 8⁴⁰.

KROMPECHER, EDMUND. Die mehrfache indirekte Kerntheilung. Mit 9 lithogr. Tafeln. 275 Seiten. gr. 8^o. Mk. 4⁰⁰.

LEHMANN, DR. O. Elektrizität und Licht. Einführung in die messende Elektrizitätslehre und Photometrie. Mit 220 Holzstichen u. 2 Tafeln. 390 Seiten. gr. 8^o. Mk. 7⁰⁰.

NOLDE, BARON EDUARD. Reise nach Innerasien, Kurdistan und Armenien 1892. Mit dem Bildnis des Reisenden und 1 Karte. 272 Seiten. 8^o. Mk. 4⁵⁰.

Pharmakologie und Toxikologie mit Beiträgen von vielen Ärzten redigirt von A. Brestaniski. 967 Seiten. gr. 8^o. Lubbd. M. 25⁰⁰.

RICHTER, CARL. Die Galvanische Verzinkung des Eisens. Mit besonderer Berücksichtigung der neueren Methoden. Mit 18 Figuren im Text. 48 Seiten. 8^o. Mk. 1⁵⁰.

SCHMIDT, DR. CARL. Das Naturereigniss der Sintflut. Akademischer Vortrag. 63 Seiten. 8^o. Mk. 1²⁰.

WELTER, DR. ADOLF. Die Tiefen Temperaturen, ihre künstl. Erzeugung, ihre Einwirkung auf Tiere, Pflanzen, Microorganismen, etc., sowie ihre Anwendung in der Industrie. 84 Seiten. gr. 8^o. Mk. 2⁵⁰.

ZITTEL, KARL A. VON. Grundzüge der Paläontologie (Paläozoologie). Mit 2048 in den Text gedruckten Abbildungen. 971 Seiten. gr. 8^o. $\frac{1}{2}$ mor. Mk. 25⁰⁰.

ZWAARDEMAKER, DR. H. Die Physiologie des Geruchs. Mit 28 Figuren im Text. 324 Seiten. gr. 8^o. Mk. 9⁰⁰.

GUSTAV E. STECHERT,

810 Broadway, New York.

Macmillan & Co.'s New Books.

Loudon and McLennan.—A Laboratory Course of Experimental

Physics. By W. J. LOUDON, B. A., LL. D., Demonstrator in Physics in the University of Toronto, and J. C. MCLENNAN, B. A., Assistant Demonstrator in Physics in the University of Toronto. 8vo, cloth, \$1.90 net.

Ostwald.—The Scientific Foundations of Analytical Chemistry.

Treated in an Elementary Manner by WILHELM OSTWALD, Ph. D., Professor of Chemistry in the University of Leipzig. Translated with the Author's sanction by GEORGE MCGOWAN, Ph. D. 12mo, cloth, pp. 207, \$1.60 net.

Hutchinson.—Hand=Book of Grasses. Treating of their Structure, Classification, Geographical Distribution and Uses. Also Describing the British Species and Their Habitats.

By WILLIAM HUTCHINSON. With Illustrations. 12mo, cloth, 75 cents net.

Laurie.—Facts about Processes, Pigments and Vehicles. A Manual for Art Students.

By A. P. LAURIE, M. A., B. Sc., Lecturer on Chemistry, St. Mary's Hospital; late Fellow King's College, Cambridge. 12mo, cloth, edge cut, \$1.00 net.

Stewart.—An Elementary Treatise on Heat.

By BALFOUR STEWART, LL. D., F. R. S., late Professor of Natural Philosophy Victoria University, Owen's College, Manchester. Sixth edition, revised, with additions, by ROBERT E. BAYNES, M. A., student of Christ Church, Oxford, and Dr. Lee's Reader in Physics. New Edition. 12mo, cloth, \$2.25 net.

Murray.—An Introduction to the Study of Seaweeds.

By GEORGE MURRAY, F. R. S. E., F. L. S. With 8 Colored Plates and 88 other Illustrations. 12mo, cloth, \$1.75 net.

Tait.—Dynamics.

By P. G. TAIT, M. A., Sec. R. S. E., Honorary Fellow of St. Peter's College, Cambridge, Professor of Natural Philosophy in the University of Edinburgh. 12mo, cloth, \$2.50 net.

Wiedersheim.—The Structure of Man. An Index to His Past History.

By DR. R. WIEDERSHEIM. Translated by H. and M. BARNARD. The translation edited and annotated and a preface written by G. B. HOWES, F. L. S., Professor of Zoölogy, Royal College of Science, London. With 105 Figures in the Text. 8vo, cloth, \$2.60 net.

Wilson.—Atlas of the Fertilization and Karyokinesis of the Ovum.

By EDMUND B. WILSON, Ph. D., Professor of Invertebrate Zoölogy in Columbia College, with the coöperation of EDWARD LEAMING, M. D., F. R. P. S., Instructor in Photography at the College of Physicians and Surgeons, Columbia College. With Illustrations. 4to, cloth, \$4.00 net. (*Columbia University Press.*)

Keith.—Plea for a Simpler Life.

By GEORGE S. KEITH, M. D., F. R. C., P. E. 12mo, cloth, \$1.00.

MACMILLAN & CO., 66 Fifth Avenue, New York.

SCIENCE

EDITORIAL COMMITTEE: S. NEWCOMB, Mathematics; R. S. WOODWARD, Mechanics; E. C. PICKERING, Astronomy; T. C. MENDENHALL, Physics; R. H. THURSTON, Engineering; IRA REMSEN, Chemistry; J. LE CONTE, Geology; W. M. DAVIS, Physiography; O. C. MARSH, Paleontology; W. K. BROOKS, Invertebrate Zoology; C. HART MERRIAM, Vertebrate Zoology; S. H. SCUDDER, Entomology; N. L. BRITTON, Botany; HENRY F. OSBORN, General Biology; H. P. BOWDITCH, Physiology; J. S. BILLINGS, Hygiene; J. McKEEN CATTELL, Psychology; DANIEL G. BRINTON, J. W. POWELL, Anthropology.

FRIDAY, OCTOBER 25, 1895.

CONTENTS:

| | |
|---|-----|
| <i>View of the Ice Age as Two Epochs, the Glacial and Champlain:</i> WARREN UPHAM | 529 |
| <i>Helium and Argon:</i> H. N. STOKES..... | 533 |
| <i>Economics of Engineering Public Works:</i> HENRY N. OGDEN | 539 |
| <i>Marine Laboratory of the U. S. Fish Commission at Wood's Hole:</i> J. I. PECK | 543 |
| <i>Geography at the British Association:</i> ROBERT HUGH MILL..... | 545 |
| <i>Scientific Notes and News:—</i> | 547 |
| <i>The Smithsonian Exhibit at Atlanta; General.</i> | |
| <i>Educational Notes and News.....</i> | 551 |
| <i>Correspondence:—</i> | 552 |
| <i>A Few More Words in regard to the New Bibliographical Bureau:</i> HERBERT HAVILAND FIELD. | |
| <i>The Dogmatism of Science:</i> GEORGE M. GOULD. | |
| <i>The Inverted Image on the Retina Again:</i> J. B. WOODWORTH; J. MCK. C. 'Crying with Two Ears:' W. H. FISHBURN. <i>Inaccurate Zoology:</i> THEODORE D. A. COCKERELL. | |
| <i>Scientific Literature:—</i> | 557 |
| <i>Verworn's Allgemeine Physiologie:</i> CHARLES S. MINOT. <i>Trevor-Battye's Ice-bound on Kolguev:</i> WILLIAM LIBBEY, JR. <i>Markham on Major James Rennell and the Rise of Modern English Geography:</i> W. M. D. <i>Oeuvres Ophthalmologiques de Thomas Young:</i> CHARLES HENRY. | |
| <i>Societies and Academies:—</i> | 563 |
| <i>The Entomological Society of Washington:</i> L. O. HOWARD. <i>The New York Academy of Sciences:</i> WM. HALLOCK. | |
| <i>New Books.....</i> | 564 |

MSS. intended for publication and books, etc., intended for review should be sent to the responsible editor, Prof. J. McKeen Cattell, Garrison on Hudson, N. Y.

Subscriptions and advertisements should be sent to SCIENCE, 1 N. Queen St., Lancaster, Pa., or 41 East 49th St., New York.

VIEW OF THE ICE AGE AS TWO EPOCHS, THE GLACIAL AND CHAMPLAIN.*

THE present paper supplements that presented by the author in the Proceedings of this Association a year ago, which showed the Quaternary era as divided into the Lafayette, Glacial and Recent periods. The Glacial period or Ice age is here more particularly reviewed, and is found divisible into two parts or epochs, the first or Glacial epoch being marked by high elevation of the drift-bearing areas and their envelopment by vast ice sheets, and the second or Champlain epoch being distinguished by the subsidence of these areas and the departure of the ice with abundant deposition of both glacial and modified drift. Epeirogenic movements, first of great uplift, and later of depression, are thus regarded as the basis of the two chief time divisions of the Ice age. Each of these epochs is further divided into stages, marked in the Glacial epoch by fluctuations of the predominant ice accumulation, and in the Champlain epoch by successively diminishing limits of the waning ice sheet.

Studies by many observers have shown that both in North America and Europe the border of the drift along the greater part of its extent was laid down as a gradually attenuated sheet; that the ice retreated and the drift underwent much subaërial erosion

* Read before the American Association for the Advancement of Science, Sept. 2, 1895.

and denudation; that renewed accumulation and growth of the ice sheets, but mostly without extending to their earlier limits, were followed by a general depression of these burdened lands, after which the ice again retreated, apparently at a much faster rate than before, with great supplies of loess from the waters of its melting; that moderate reëlevation ensued, and that during the farther retreat of the ice sheets prominent moraines were amassed in many irregular but roughly parallel belts, where the front at successive times paused or re-advanced under secular variations in the prevailing temperate and even warm climate by which, between the times of formation of the moraines, the ice was rapidly melted away.

Such likeness in the sequence of glacial conditions doubtless implies contemporaneous stages in the glaciation of these two continents; and the present writer believes that it is rather to be interpreted as a series of phases in the work of a single ice sheet on each area than as records of several separated and independent epochs of glaciation, differing widely from one another in their methods of depositing drift.

Under the latter view, however, Geikie distinguishes no less than eleven stages or epochs, glacial and interglacial, which he has very recently named (*Journal of Geology*, Vol. III., pp. 241-269, April-May, 1895), since the publication last year of the new edition of his 'Great Ice Age,' in which, however, they were fully described. These divisions of the Glacial period are as follows: 1. The Scanian or first glacial epoch; 2. The Norfolkian or first interglacial epoch; 3. The Saxonian or second glacial epoch; 4. The Helvetian or second interglacial epoch; 5. The Polandian or third glacial epoch; 6. The Neudeckian or third interglacial epoch; 7. The Mecklenburgian or fourth glacial epoch; 8. The Lower Forestian or fourth interglacial epoch; 9. The Lower Turbarian or fifth

glacial epoch; 10. The Upper Forestian or fifth interglacial epoch; and 11. The Upper Turbarian or sixth glacial epoch.

The earliest application of such geographic names to the successive stages and formations of the Ice age appears to be that of Chamberlin in his two chapters contributed to the new third edition of Geikie's admirable work before mentioned, in which he names the Kansan, East Iowan, and East Wisconsin formations. For the second and third he has since adopted the shorter names, Iowan and Wisconsin. This classification he has more recently extended (in the *Journal of Geology*, Vol. III., pp. 270-277, April-May, 1895), the interglacial stage and deposits between the Kansan and Iowan till formations being named Aftonian, and the Toronto interglacial formation, previously named, being referred, with some doubt, to an interval between the Iowan and Wisconsin stages. Chamberlin correlates, with a good degree of confidence, his Kansan stage of maximum North American glaciation with the maximum in Europe, which is Geikie's Saxonian epoch; the Aftonian stage as Geikie's Helvetian; the Iowan as the European Polandian; and the Wisconsin or moraine-forming stage of the United States as the Mecklenburgian, which was the stage of the 'great Baltic glacier' and its similarly well developed moraines. According to the law of priority, the names of the Kansan, Iowan and Wisconsin formations and stages should also be applied to these European divisions of the Glacial series, for the studies of Geikie and Chamberlin show them to be in all probability correlative and contemporaneous.

Differing much from the opinions of Geikie, and less widely from those of Chamberlin, concerning the importance, magnitude and duration of the interglacial stages, but agreeing with Dana, Hitchcock, Wright, Kendall, Falsan, Holst, Nikitin and others

in regarding the Ice age as continuous, with fluctuations but not complete departure of the ice sheets, my view of the history of the Glacial period, comprising the Glacial epoch of ice accumulation and the Champlain epoch of ice departure, may be concisely presented in the following somewhat tabular form. The order is that of the advancing sequence in time, opposite to the downward stratigraphic order of the glacial, fluvial, lacustrine and marine deposits.

EPOCHS AND STAGES OF THE GLACIAL PERIOD.

I. The Glacial Epoch.

1. THE CULMINATION OF THE LAFAYETTE EPIEROGENIC UPLIFT, affecting both North America and Europe, raised the glaciated areas to so high altitudes that they received snow throughout the year and became deeply ice-enveloped. Valleys and fjords show that this elevation was 1,000 to 4,000 feet above the present height.

Rudely chipped stone implements and human bones in the plateau gravels of southern England, 90 feet and higher above the Thames, and the similar traces of man in high terraces of the Somme valley, attest his existence there before the maximum stages of the uplift and of the Ice age. America appears also to have been already peopled at the same early time.

The accumulation of the ice sheets, due to snowfall upon their entire areas, was attended by fluctuations of their gradually extending boundaries, giving the Scanian and Norfolkian stages in Europe, and an early glacial recession and re-advance in the region of the Moose and Albany rivers, southwest of James Bay.

2. KANSAN STAGE. Farthest extent of the ice sheet in the Missouri and Mississippi river basins, and in northern New Jersey. The Saxonian stage of maximum glaciation in Europe.

Area of the North American ice sheet,

with its development on the Arctic archipelago, about 4,000,000 square miles; of the Greenland ice sheet, then somewhat more extended than now, 700,000 square miles or more, probably connected over Grinnell land and Ellesmere land with the continental ice sheet [the area of Greenland is approximately 680,000 square miles, and of its present ice sheet 575,000 square miles]; of the European ice sheet, with its tracts now occupied by the White, Baltic, North and Irish seas, about 2,000,000 square miles.

Thickness of the ice in northern New England and in central British Columbia, about one mile; on the Laurentide highlands, probably two miles; in Greenland, as now, probably one mile or more, with its surface 8,000 to 10,000 feet above the sea; in portions of Scotland and Sweden, and over the basins of the Baltic sea, a half mile to one mile.

3. HELVETIAN OR AFTONIAN STAGE. Recession of the ice sheet from its Kansan boundary northward about 500 miles to Barnesville, Minn., in the Red river valley; 250 miles or more in Illinois, according to Leverett; but probably little between the Scioto river, in Ohio, and the Atlantic coast, the maximum retreat of that portion being 25 miles or more in New Jersey. A cool temperate climate and coniferous forests up to the receding ice border in the upper Mississippi region. Much erosion of the early drift.

The greater part of the drift area in Russia permanently relinquished by the much diminished ice sheet, which also retreated considerably on all its sides.

During this stage the two continents probably retained mainly a large part of their preglacial altitude. The glacial recession may have been caused by the astro-nomic cycle which brought our winters of the northern hemisphere in perihelion of between 25,000 and 15,000 years ago.

4. IOWAN STAGE. Renewed ice accumu-

lation, covering the Aftonian forest beds, and extending again into Iowa, to a distance of 350 miles or more from its most northern indentation by the Aftonian retreat, and re-advancing about 150 miles in Illinois, while its boundary eastward from Ohio probably remained with little change.

The Polandian stage of renewed growth of the European ice sheet, probably advancing its boundaries in some portions hundreds of miles from the Helvetian retreat.

II. *The Champlain Epoch.*

5. CHAMPLAIN SUBSIDENCE; NEUDECKIAN STAGE. Depression of the ice-burdened areas mostly somewhat below their present heights, as shown by fossiliferous marine beds overlying the glacial drift up to 300 feet above the sea in Maine, 560 feet at Montreal, 300 to 400 feet from south to north in the basin of Lake Champlain, 300 to 500 feet southwest of Hudson and James bays, and similar or less altitudes on the coasts of British Columbia, the British Isles, Germany, Scandinavia and Spitzbergen.

Glacial recession from the Iowan boundaries was rapid under the temperate (and in summers warm or hot) climate belonging to the more southern parts of the drift-bearing areas when reduced from their great preglacial elevation to their present height or lower. The finer portion of the englacial drift, swept down from the ice fields by the abundant waters of their melting and of rains, was spread on the lower lands and along valleys in front of the departing ice as the loess of the Missouri, the Mississippi and the Rhine. Marine beds reaching to a maximum height of about 375 feet at Neudeck, in western Prussia, give the name of this stage.

6. WISCONSIN STAGE. Moderate reëlevation of the land in the northern United States and Canada, advancing as a perma-

nent wave from south to north and north-east; continued retreat of the ice along most of its extent, but its maximum advance in southern New England, with fluctuations and the formation of prominent marginal moraines; great glacial lakes on the northern borders of the United States.

The Mecklenburgian stage in Europe. Conspicuous moraine accumulations in Sweden, Denmark, Germany and Finland, on the southern and eastern margins of the great Baltic glacier. No extensive glacial re-advance between the Iowan and Wisconsin stages, either in North America or Europe.

7. WARREN STAGE. Maximum extent of the glacial Lake Warren, held on its north-east side by the retreating ice border, one expanse of water, as mapped by Spencer, Lawson, Taylor, Gilbert and others, from Lake Superior over Lakes Michigan, Huron and Erie, to the southwestern part of Lake Ontario; its latest southern beach traced east by Gilbert to Crittenden, N. Y., correlated by Leverett with the Lockport moraine.

This and later American stages, all of minor importance and duration in comparison with the preceding, cannot probably be shown to be equivalent with Geikie's European divisions belonging in the same time.

8. TORONTO STAGE. Slight glacial oscillations, with temperate climate nearly as now, at Toronto and Scarborough, Ont., indicated by interbedded deposits of till and fossiliferous stratified gravel, sand and clay. Although the waning ice sheet still occupied a vast area on the northeast, and twice re-advanced, with deposition of much till, during the formation of the Scarborough fossiliferous drift series, the climate then, determined by the Champlain low altitude of the land, by the proximity of the large glacial lake Algonquin, succeeding the larger lake Warren, and by the eastward and northeastward surface atmospheric currents

and courses of all storms, was not less mild than now. The trees whose wood is found in the interglacial Toronto beds now have their most northern limits in the same region.

9. IROQUOIS STAGE. Full expansion of the glacial Lake Iroquois in the basin of the present Lake Ontario and northward, then outflowing at Rome, N. Y., to the Mohawk and Hudson rivers. Gradual reëlevation of the Rome outlet from the Champlain subsidence had lifted the surface of Lake Iroquois in its western part from near the level of the present lake at Toronto to a height there of about 200 feet, finally holding this height during many years, with the formation of the well developed Iroquois beach.

Between the times of Lakes Warren and Iroquois, the glacial Lake Lundy, named by Spencer from its beach ridge of Lundy's Lane, probably had an outlet east to the Hudson by overflow across the slope of the highlands south of the Mohawk; but its relationship to the glacial Lake Newberry, named by Fairchild as outflowing to the Susquehanna by the pass south of Seneca Lake, needs to be more definitely ascertained.

10. ST. LAWRENCE STAGE. The final stage in the departure of the ice sheet which we are able to determine from the history of the Laurentian lakes and St. Lawrence valley was when the glacial Lake St. Lawrence, outflowing through the Champlain basin to the Hudson, stretched from a strait originally 150 feet deep over the Thousand Islands, at the mouth of Lake Ontario, and from the vicinity of Pembroke, on the Ottawa river, easterly to Quebec or beyond. As soon as the ice barrier was melted through, the sea entered these depressed St. Lawrence, Champlain and Ottawa valleys; and subsequent epeirogenic uplifting has raised them to their present slight altitude above the sea level.

Later stages of the glacial recession are doubtless recognizable by moraines and other evidences, the North American ice sheet becoming at last, as it probably also had been in its beginnings, divided into three parts, one upon Labrador, another northwest of Hudson Bay, as shown by Tyrrell's observations, and a third upon the northern part of British Columbia. From my studies of the glacial Lake Agassiz, whose duration was probably only about 1,000 years, the whole Champlain epoch of land depression, the departure of the ice sheet because of the warm climate so restored, and most of the reëlevation of the unburdened lands, appear to have required only a few (perhaps four or five) thousand years, ending about five thousand years ago. These late divisions of the Glacial period were far shorter than its Kansan, Aftonian and Iowan stages; and the ratio of the Glacial and Champlain epochs may have been approximately as ten to one. The term Champlain conveniently designates the short final part of the Ice age, when the land depression caused rapid though wavering retreat of the ice border, with more vigorous glacial currents on account of the marginal melting and increased steepness of the ice front, favoring the accumulation of many retreatal moraines of very knolly and bouldery drift.

WARREN UPHAM.

CLEVELAND, OHIO.

HELIUM AND ARGON.

BRIEF accounts of the discovery of helium and argon have already appeared in the pages of this journal. More recently, several important observations have been made, which, while not establishing with certainty the nature of these substances and their places in the system of the elements, at least afford a reasonable basis for speculation.

Helium was originally obtained from the

uranium minerals cleveite, bröggerite and Connecticut uraninite. Ramsay has since detected it in small amounts in several other minerals and in the gases occluded or combined in certain meteoric irons. The uranium minerals give the best yield, but it is also found in smaller quantities in samarskite, orangite and mouzite, and in traces in ytrotantalite, hjelmite, fergusonite, tantalite, polycrase and xenotime. All of these, including the uranium minerals above mentioned, are of comparatively rare occurrence and are found in small quantities only. They are all of complex composition and each contains several so-called 'rare earths.' It is a noteworthy fact that all minerals thus far found to contain helium consist in part of one or more of the elements uranium, thorium and yttrium, and it would seem that it is in some way associated with these, especially with uranium. As to the nature of this association nothing whatever is known, and attempts to cause them to recombine with helium have thus far failed.

Helium has also been found in the gases escaping from certain mineral springs. Kayser, of Bonn, has detected it in the gas from the Wildbad spring in the Black Forest. After sparking with oxygen to remove nitrogen, which is the chief constituent, 340 c. c. of the gas left a residue of 9 c. c., which gave a brilliant helium spectrum. Bouchard has found it associated with nitrogen and sometimes also with argon, in the gas obtained from several sulphur springs in the Pyrenees. As it is thus constantly escaping; we might well expect to detect it in traces in the atmosphere, and Kayser claims to have observed faint helium lines in the spectrum of the purest argon obtained from the atmosphere of Bonn. In fact, it seems to be a very widely distributed substance.

Cleve and Langlet have obtained helium with a density as low as 2.02, or about

double that of hydrogen; it is, therefore, next to hydrogen, the lightest gas known. This figure corresponds to a molecular weight of 4.04, and since the molecules of the gas appear to consist of single atoms, like those of argon, 4.04 represents the approximate atomic weight also. The importance of this observation lies in the fact that, although our present classification of the elements would lead us to infer the existence of several elements with atomic weights between those of hydrogen (at. wt. 1) and lithium (at. wt. 7), none of these are known. Helium may, therefore, well be one of these missing substances.

Careful spectroscopic studies by Crookes, Lockyer, Runge and Paschen, and others, have shown, however, that what we now call *helium* is not a single substance, but a mixture of two or more hitherto unknown gases. The composition of the mixture varies both qualitatively and quantitatively according to the source from which it is obtained. Crookes has published a very elaborate study of the spectra of samples of helium from different varieties of uraninite, from which it appears that even these are not absolutely identical. Sixteen bright lines are mentioned as common to all these samples of helium, including the famous D_3 line, first seen by Lockyer and Frankland in the solar spectrum. The gas from Connecticut uraninite seems to be the most complex and shows fourteen strong lines which are absent from the spectra of other varieties and presumably belong to another element. Twenty-seven lines are mentioned which seem to coincide with lines of the solar spectrum.

Runge and Paschen, who have studied the spectrum of the gas from cleveite, including the invisible ultra-red portion, have reached the conclusion that even this gas consists of two substances, one of which, the true helium, giving the D_3 line, is denser than the other (unnamed) constitu-

ent, which also shows a characteristic spectrum. The difference of density was detected by the slower rate of diffusion of the true helium, implying higher density. From spectroscopic considerations they are able to separate the composite spectrum into its two constituents, and to conclude that the true helium may have an atomic weight of about 5, and the other of not far from 3. Both of these substances, according to Kayser, are present in the gas from the Wildbad spring, while according to Bouchard helium from the Pyrenean springs also contains a second ingredient. The lines of both constituents of helium have also been noted in the spectra of several stars.

It was formerly asserted that helium and atmospheric argon have a constituent in common, this belief being based on the existence of a certain set of spectral lines common to both. Recent observations by Lockyer, with an instrument of high dispersive power, indicate that this coincidence is not exact, and hence that the theory of a common constituent is without foundation.

The only evidence favoring the view that atmospheric argon, as thus far obtained, is pure is found in the apparently constant boiling point of liquid argon, as observed by Olszewski. It may be questioned whether an experiment with only 1-10 c. c. of liquid is sufficient to prove the total absence of other substances of unknown boiling points. All samples of atmospheric argon naturally have the same composition, being derived from the same source, and argon from other sources has not yet been studied with sufficient accuracy to throw any light on the matter. It is therefore quite likely that the atomic weight of 40 will have to be changed to the extent of one or more units.

From these results it is obvious that the present figures for the atomic weights of

helium and argon, which are based on density determinations with impure material, must be regarded as provisional, but it is evident that one at least of the constituents of crude helium must have an atomic weight lower than the mean and hence must precede lithium. As it is possible that both crude helium and crude argon contain even more than two gases, the problem of their complete separation will doubtless be one of considerable difficulty, especially as all seem to possess a high degree of inertness.

The few experiments thus far made for the purpose of ascertaining if argon is a constituent of living beings have failed to detect it.

At present there is no evidence that any of these gases are decomposable into simpler constituents, and until such evidence is forthcoming we may continue to regard them as elementary.

Attempts to produce compounds of argon have given some indications of succeeding, but as yet no substances of definite and constant composition have been obtained. Besides the compound with benzene vapor described by Berthelot, this chemist has obtained a solid by submitting a mixture of argon and carbon disulphide vapor, confined over mercury, to the action of the electric discharge. This substance is said to evolve argon on heating. Ramsay found that, by forming an electric arc between carbon rods in an atmosphere of argon, the spectrum of argon nearly vanished after several hours' action, its place being taken by a brilliant 'channeled' spectrum. According to Crookes this shows many analogies with the spectra of carbon compounds, and may well proceed from a compound of carbon with argon. If Ramsay's observation that an *increase* of one fifth volume occurs should be confirmed, it would seem to do away with the view that argon molecules are monatomic, for a monatomic gas cannot increase in volume on entering into combination.

It was early observed that the metallic electrodes in the Plücker tubes used for obtaining spectra were very effective in removing traces of nitrogen. Even helium seemed to be slowly absorbed, its spectrum gradually becoming fainter and ultimately vanishing. Troost and Ouvrard have found that a powerful silent discharge through tubes of argon or helium containing magnesium or even platinum causes absorption of the gases. The absorption is exceedingly slow, but is ultimately complete. Nothing is known as to the nature of the products.

The elementary nature of helium has been very generally conceded. Several hypotheses assuming argon to be a compound of known or unknown elements have been suggested, most of which are without the least experimental basis, and need not be noticed here. A view which earlier met with considerable approval is that the argon molecule consists of three nitrogen atoms, N_3 . This allotropic form of nitrogen has never been obtained, and we have no means of predicting whether it would be more stable than the common form, N_2 . If more stable, and if formed in small amounts in the course of ages, it would tend to accumulate in the atmosphere. This view was supported by a not very close coincidence of densities, argon having a density of about 20, while the density of N_3 would be 21. Not the slightest evidence has been found, however, that argon and nitrogen are convertible into each other, even in traces, while such transformations are quite readily effected in all known cases of allotropism. Neither is argon formed when nitrogen is liberated from combination. If it is a more stable form of nitrogen it should be one, if not the main product under these circumstances, just as ordinary oxygen, not ozone, is the chief product when this element is set free. Until it can be shown that the evidence of the specific heat ratio, which is based on the kinetic theory of gases, is inconclusive, or

until argon is actually decomposed into simpler or familiar substances, we must regard it as a new element.

The elementary nature of the new gases being conceded, the first question which arises is whether they represent an entirely new order of substances, or whether they can be harmonized with the classification which has been found to apply to all known chemical elements whose properties have been established with any degree of exactness, and if so whether this system will admit of their adoption without any essential change, or whether it must be more or less modified and extended.

Our present classification is known as the Periodic or Natural System, and is based on a consideration of the broad chemical properties of the elements, rather than on special similarities or differences such as are considered in a classification for analytical or other practical purposes. If the elements be arranged in the order of increasing atomic weights there is a gradual modification of chemical properties as we ascend in the series, but this does not proceed uninterruptedly in the same sense through the entire list. At certain points there is a break, and the following element has properties resembling one several places back. This abrupt change is perhaps most obvious in respect to the metallic and base forming, and the non-metallic and acid forming properties, and is well illustrated in the following small table, which gives the first part of the series.

| | | | | | | |
|-------|------------|----|------|-------|-------|-------|
| Li | Be | B | C | N | O | F |
| 7.02 | 9 | 11 | 12 | 14.03 | 16 | 19 |
| Na | Mg | Al | Si | P | S | Cl |
| 23.05 | 24.3 | 27 | 28.4 | 31 | 32.06 | 35.45 |
| K | | | | | | |
| 39.11 | etc., etc. | | | | | |

Lithium (7.02), the element of the lowest known atomic weight excepting hydrogen, is a pronounced metal, electropositive,

and forming a strongly basic 'alkali.' Beryllium (9) is still metallic, but with boron (11) the metallic, base forming properties have vanished, and it is a weak acid former, while in fluorine (19) we have an element which is gaseous, highly negative, an acid former, and as different from lithium as could well be imagined. The next element, sodium (23.05), does not possess in a still stronger degree the properties shown by fluorine, as we might expect; on the contrary, it closely resembles lithium. A similar gradual modification again occurs as we proceed, the metallic, basic properties fading out and being gradually replaced by non-metallic, acidic properties. Silicon (28.4) is no longer a metal and chlorine (35.45) is a gas, chemically and physically much resembling fluorine. Beginning with the next element, the alkali metal potassium (39.11), a similar series of gradual transitions is gone through, followed by a sudden interruption and reversion, and this is several times repeated through the whole list, with certain modifications which it is not essential to our purpose to consider. Each set of elements beginning with a metal and ending with a non-metallic acid former is called a *period*. Those elements which fall into the same vertical column constitute a *group* or *natural family* and have a marked resemblance, lithium being followed by sodium, potassium, rubidium and cesium, the *alkali metals*, and fluorine by chlorine, bromine and iodine, the *halogens*, all of which give rise to strong acids.

This system, while presenting some difficulties, just as nearly every system of natural phenomena does, bears abundant evidence of being based on some natural cause, of the nature of which we know as yet absolutely nothing. Quite a number of blanks or 'missing links' occur, but it is generally expected that elements will ultimately be discovered which will fit into these places; an expectation which has in several cases

been realized in the most striking manner. The properties of helium and argon and their atomic weights, as at present roughly determined, do not hold out any promise that these elements will fit into any of the vacancies; on the contrary, it seems quite certain that they will not.

The abrupt jump from the halogen at the end of each period to the alkali metal beginning the next, in contrast with the gradual change elsewhere observed, is one of the most remarkable facts in chemistry. Given the existence of a periodicity of properties, we should rather expect the periods to be connected by a series of elements showing gradations in a reverse order, or at least by transitional elements of intermediate properties. We should expect to find a continuous curve with maxima and minima rather than a series of disconnected lines. While the law which makes the properties of elements a function of their atomic weights is wholly unknown we cannot assert that this must be so, and it is rather our reliance on the principle of continuity which leads us to feel that it should be so. We may assume that the connecting links actually exist though as yet undiscovered. It is on such an hypothesis that the most plausible attempts to classify the new elements have been made.

Rayleigh and Ramsay, at the close of their memorable paper on argon, read before the Royal Society in January, pointed out a possible way of harmonizing their discovery with the Periodic Law. They called attention to the variation of valency in the latter half of the second period:

| | | | | |
|------------|----------|-------------|----------|-----------|
| Element: | Silicon. | Phosphorus. | Sulphur. | Chlorine. |
| Valency: | 4 | 3 - 5 | 2 - 6 | 1 - 7 |
| Atomic wt. | 28.4 | 31 | 32.06 | 35.45 |

The next known element is potassium, beginning the third period with an atomic weight 39.11. Between this and chlorine, however, we may imagine another element,

which would form a continuation of the second period and which, following out the above order, would have an atomic weight between 35.45 and 39.11 and a valency of 0 or 8. A valency of 0 would imply absence of combining power, in other words, great inertness and molecules consisting of single atoms, both of which characterize argon. As pointed out above, the atomic weight of argon may prove to be less than the upper limit of 39.11.

Lecoq de Boisbaudran and Julius Thomsen have advanced hypotheses which consist essentially in the assumption of an eighth group of elements, intermediate between and transitional from the halogens to the alkali metals. Thomsen's table is here given, the hypothetical transitional elements being printed in heavy type. It is otherwise simply an abbreviated form of Lothar Meyer's table of the Periodic System. The dashes represent some of the missing elements above referred to, and the dots places of elements omitted for the sake of clearness.

| | | | | | | | | |
|-----------------------|-----|-----|-------|-------|-----|-----|------|------------|
| I. Hydrogen | | | | 1 | — | — | — | 4 |
| II. Lithium-fluorine | 7 | 9 | 11 | 12 | 14 | 16 | 19 | 20 |
| III. Sodium-chlorine | 23 | 24 | 27 | 28 | 31 | 32 | 35.5 | 36 |
| IV. Potassium-bromine | 39 | 40 | | | 79 | 80 | 84 | 84 |
| V. Rubidium-iodine | 85 | 87 | | | 125 | 127 | 132 | 132 |
| VI. Cesium | 133 | 137 | | | — | — | — | 212 |
| VII. ——— | — | — | | | — | — | — | 292 |

The atomic weights 4 and 36 would correspond to the chief ingredients of what we now call helium and argon. It must be borne in mind that the figures in the last column may be altered several units without affecting the theory.

It has been shown, however, as above stated, that helium and perhaps argon are more or less contaminated with other new elements. Until the atomic weights of these contaminating substances have been determined, it would be useless to assign them places in Thomsen's system. There are several possibilities. They may be other members of the last column.

Instead of only one transitional element between each period there may be several, and we would have, instead of only one, two or even three new columns on the right of the table. There remain several places open between hydrogen and lithium, and we cannot at present deny the possibility of unknown elements even preceding hydrogen. Although this element heads the list, there is no evidence of a natural reason for its occupying this unique position. On the hypothesis of a common origin of the elements from one primitive substance, the 'protyle' of Crookes, the existence of such substances is by no means improbable. The most exact atomic weight determinations indicate that the true unit of the whole system, the greatest common divisor of all atomic weights, if it exists at all, must be a comparatively small fraction of the atomic weight of hydrogen, a mass which could give rise to several elements still lower in the scale. The discovery of such elements would be scarcely more surprising than that of helium, and that they have not been thus far detected, even by the spectroscope, is no more remarkable than that this instrument overlooked argon.

While Thomsen's view cannot at present be regarded as more than a suggestion, it is certainly the one which best accords with our present knowledge. The Periodic System, imperfect as it still is, bears unquestionable evidence of some fundamental natural law, but it is at present as great a mystery as the natural system of plants and animals before the days of the evolution theory. The problem which the chemist faces to-day has much resemblance to that which confronted the biologist in those times. There appears to be no reason for expecting the recent discoveries to be in any way revolutionary, but they will doubtless contribute to the solution of the great problem of the chemist, not only by the enlarged conceptions which they involve, but

also by stimulating the search for new elements and the efforts to ascertain the true relation of those already known. In this sense the present year may well mark the beginning of a new era in chemical discovery.

H. N. STOKES.

WASHINGTON, October, 1895.

ECONOMICS OF ENGINEERING PUBLIC WORKS.

It has become almost proverbial that the inhabitants of new countries are in many respects lavish and extravagant. Our Puritan forefathers were undoubtedly the most rigorous and economical people that ever faced privation and hardship, yet it can hardly be gainsaid that their descendants have lost that characteristic of frugality to such an extent as to make the American people distinguished for extravagance and prodigality; notably so in this nineteenth century. As a people we have not spent our wealth on the fine arts, but on silks and velvets for clothing, on diamonds and jewelry for adornment, on luxuries in food and drink, and in similar indulgences of a low order, and we are now beginning to feel the evil results of this course of action.

This lavish expenditure of money has been made possible by the great accumulation of wealth resulting from the natural resources of the land, the wealth of the soil, of the forests, of the mines, and from the labor and frugality of the pioneers. We, of this generation, not only have felt no need to practice the economies familiar to other countries, but we have been impelled by the consciousness of our national and personal possessions to make use of them in what has often been vain and extravagant display.

Then again, this general success in the battle of life has made individuals self-reliant, or rather has prevented that feeling of the need of coöperation which only lately has shown signs of existence. There

was a time when men rose unaided to the top round of financial success, made their own fortunes, and spent them as their tastes dictated; individuals hired individuals, and laborers worked for this man or for that, as fancy or personal preference led them; but not now. By means of coöperation and combination with others, man is enabled to have advantages which, as an individual, he cannot secure; for we have begun to act on the principle that, while one man's opinions may be ignored, there is power in the expressed wish of numbers. Trusts and brotherhoods are alike in trying to secure some advantage for their individual members to the exclusion of the rest of the world. Man has reached a point where he sees that to benefit himself he must be willing to help a few others as well. One step has been taken away from individualism, but only one, and that a short one. Let us look at some instances of corporations and associations seeking their own advantage at the expense of the public good. This is sometimes done wilfully, in the face of public needs and desires, and sometimes through blindness and ignorance.

There are in the United States thousands of miles of railroad which have been uselessly built. The money for their construction has been practically taken out of the store of the world's wealth and literally buried in the ground. They have been built either by shortsightedness or by knavishness on the part of a few, and can only be maintained by a higher rate on all railroad business, and a correspondingly increased tax on all who use the railroads. No one would hesitate to say that were the New York Central Railroad, for example, to have all the freight business between New York and Buffalo, instead of having to divide with its competing roads, the rate per ton on freight would be greatly lowered and yet a working profit be maintained. Aside, then, from the local business, which

could generally be more economically managed by feeders than by trunk lines, competing lines enforce higher rates for the service rendered. Had a proper regard for public economy been maintained the West Shore Railroad, for instance, would never have been built.

Now look at the management of our municipal affairs. Water pipes under the care of one commission are laid in one trench, gas pipes under another management in a second trench, and so with the sewers and the steam pipes, and the conduits for wires and for other purposes. Each company is responsible for its own ditch and its contents, but the cost of the trench is, in each case, added to the cost of the service rendered, and the community has to pay for the many managements and their lack of coöperative understanding. It is not an unknown thing after a town is well paved to have the pavement ruined by the subsequent laying of water and sewer pipes, with the additional expense of repaving the street over the trench. Were all pipes put together in a suitable and accessible conduit, paid for by the managements of the different pipe lines, and were the conduits built before any of the trenches are dug, a certain net gain to the community would ensue. Conduits could, in most cases, be built for less than the total expense of the trenches, and could be constructed in the streets of our large cities, thus avoiding the dead loss incurred whenever the streets are torn up for repairs.

Another instance is found in our colleges and universities, where useless duplication, arising from petty jealousy and departmental rivalry, results in direct loss to the institution. One professor delivers a lecture on iron ore, as part of the course in geology, and another, lecturing on the strength of materials, goes over the same ground. One department buys a machine to test the strength of boiler plates; another

invests in one to test bridge rivets, and another in one to test building stone; while a single machine would serve all three departments were there some authoritative head to make proper arrangements.

Our elective machinery is run in the same spendthrift way. City and National elections come at different times, and the cost to the country is doubled in consequence. In November a Presidential election is held, and the following Spring the same big engine—inspectors, clerks, halls, etc.—must be put in motion, and run a whole day for the purpose of electing a school trustee or a road commissioner. With our taxes it is the same story. In February the assessors make out lists, perform all the necessary work and the State tax is collected at great expense; in June the same outlay, both of time and money, is again necessary to collect the city tax; while, were both done at the same time, nearly half the labor and expense could be saved.

Instances could be cited almost indefinitely to show that we continually spend a great deal of money to no purpose, money which does not add to the store of the world's wealth, money which, so far as any lasting good or any visible result is concerned, is absolutely thrown away. We have grown up with it, and it seems natural and necessary to us. Our vision is limited, and provided the thing to be done is done, we do not concern ourselves as to whether, or not, it is accomplished in the most economical and altruistical manner possible. New ways are being forced on us, as they have been on older countries, and as a nation we are bound to consider the questions of the hour in a broader and more communistic fashion than any individual, who weighs only the chances of his personal advantage, would do. It does not follow, that we, as a people, are not capable of improvement because there are instances

where, as a people, we have allowed ourselves to be imposed upon. The history of no other nation is so full of examples of genius in adapting the means at hand to secure required ends. Bogie trucks, pin-connected trusses, timber trestles and bridges were all called into existence by the necessities of work, and by the American genius in employing the material at hand. The modern steel construction in city buildings comes under the same head. A study of the patent office records proves that we are extravagant, not because we are incapable of developing methods, but because it has not been necessary for us to be otherwise. This seems to point to the fact that we have become accustomed to care only for ourselves and our private interests and are neglecting public economies.

There are, however, growing evidences of progress in this direction. The Interstate Commerce Law is designed to restrict railroad charges between non-competing points to what shall be reasonable rates for the service rendered. Railroad corporations can no longer obtain franchises to construct lines parallel to existing lines, unless it is clearly shown that the traffic is too heavy for one road. Four States of the Union now refuse to give the right of eminent domain to railroads, as has been done in times past. Even to obtain a franchise for an electric street line it must be shown that there is a public demand for its construction. Within the past three months the Supreme Court of New York has confirmed a decision of the State Railway Commission to the effect that no electric road may be constructed parallel to a railway, unless it is proved that public necessity and convenience require it. The Courts held that exorbitant rates on the steam railroad were to be avoided by application to the Railway Commission, and redress had through them. The public has an inherent right, however, to the best service for the least money, and

if trolley lines can give better service at lower rates than the steam roads, public economy demands their construction and use.

Deep water canals, which are awakening so much interest at present, afford another example. Heavy and bulky freight of certain kinds can indisputably be carried more economically by canal than by rail, and yet the railroads keep up a bitter competition for that class of matter, and have even been known to carry freight at less than cost in order to force out of competition the canals running along their line of way. It would be far better were the work of the railroads restricted to the transportations of perishable matter and other things whose rapid delivery is important, and all else entrusted to the canals, whose operating expenses, even with the interest on the original outlay, are generally enough smaller to make a considerable difference in the cost of transportation. The possibility of carrying freight from New York to Chicago means the possibility of carrying it from Europe to Chicago, and means also saving to the community of the cost of reloading in New York. A deep water canal from Chicago to New Orleans would mean a cheap water connection between the North and the South, and again to the Nation the amount saved on freight.

In New York a great step has been recently taken in the acquisition by the State of a quantity of land. This act of remarkable foresight is a wise provision for future citizens. New Jersey has shown equal wisdom in reserving her mountainous and water-bearing country as a gathering ground, that all her cities may have a pure and unlimited water supply.

Boston, moved, to be sure, by her own immediate needs, is about to offer to thirty or forty cities in that vicinity the opportunity to share in a large enterprise, by which each may secure good water at reduced

rates. Some years ago, Boston, in the same manner offered to the cities along the Charles and Mystic rivers a plan for the disposal of their sewage, as, by thus joining forces, the cost to each would be greatly lowered. Many examples of the recent tendency towards municipal economy might be enumerated; among others the modern sentiment on the value of street railroad franchises; the feeling that gas and water should be furnished to citizens at moderate rates; for no private company has the right to demand more than a reasonable profit; also that it is the duty of the city authorities to exercise their right of jurisdiction in these matters. There are, too, signs of growing enlightenment in the direction of caring for waste. People are beginning to realize the dead loss incurred by mixing different kinds of garbage, some of which have a value. There are now many manufactories that use as raw material what, in time past, was regarded as waste product. We might go on to speak of the folly of individuals making dirt which the municipality must clean up; to the use of water meters, to prevent waste even where there is plenty of water; all these things go to show inclination towards more careful consideration of municipal economy.

Apply this tendency to the question of water supply, and make the maintenance of its purity a question of public economy. Water is not only a prime requisite of food, but it also acts as chief among our scavenging agents. In our water works it does double duty; it brings water for cooking, drinking and cleaning into our houses, and after being made foul and unhealthy it carries away with it most of the waste of our vital processes. The large streams of a country act in the same way as the water in the pipes of a house. They bring into a city supplies for its daily life, and they carry away the waste. Since, except for the city at the river's source, the stream

cannot serve both purposes, it must be decided for each stream which service it shall perform. This question should be settled by some authority, learned not only in the quality of the stream, and its inherent fitness for being used for either purpose, but learned also in the economic phase of the question. Would the community as a whole be better served by having, for example, the Passaic river kept, by the exercise of some authority, pure and wholesome for domestic purposes, or by allowing it to be made an open sewer, a proper place for the discharge of all manufacturing waste. Shall the stream in question remain throughout its length as pure as at its source, or shall it be avowedly given up to pollution, is a question to be settled, not by asking if any one city along its banks desires to use the water of the stream for drinking purposes, but by a determination of the needs of the community. Contamination, or that which renders a stream unfit for further domestic use, is caused by the introduction of manufacturing wastes and of human refuse, and in order to keep a stream pure these two sources of contamination must be avoided, either by keeping all such matter out of the stream entirely, or by requiring some process of purification which shall render them non-injurious. It seems almost inevitable that these waste products will sooner or later find their way into the stream. It has been proved that intermittent filtration, well and carefully managed, will restore polluted water to a pure condition, and the practicability of its use for large cities is now being tested in several places in this country. The economical question to be answered with reference to any stream whose water is to be used at any point for drinking purposes, is: should the polluted water be *made pure* in such quantities as are needed for a specific use, or should the stream be *kept pure* by prohibiting its pollution at any point; that is by re-

quiring the purification of waste before it enters the stream. The general trend of modern legislation is towards the latter course, no doubt due largely to the influence of the increasing number of State Boards of Health; but why not make it a question of municipal economy?

If Newark, for example, wants her water supply from the Passaic river, whose waters are polluted, does it not seem absurd, speaking broadly, that she should be required to purify her supply of twenty million gallons a day when the pollution comes, perhaps, from one mill discharging only one million gallons? If one woolen mill on a stream causes pollution that obliges a dozen cities further down the stream to construct filtration works, provided they are to drink the water with any degree of safety, would it not be more economical to oblige the one mill to purify its comparatively small amount of waste before it is allowed to enter the stream, instead of permitting the pollution of the whole river? *Vice versa*, streams already devoted to the service of mills and manufactories may better serve the general economy by continuing in that service; and the one or two cities can build filtration plants at less cost than that of purifying the wastes of all the manufactories. Only a careful study of the condition of the communities along the banks can ascertain in which way the gain to the whole people is found, in which way public economy is best maintained.

HENRY N. OGDEN.

CORNELL UNIVERSITY.

MARINE LABORATORY OF THE UNITED STATES FISH COMMISSION AT WOOD'S HOLE STATION, SUMMER SEASON OF 1895.*

THE present 'Laboratory of Scientific Research' was constructed after Professor

*This has been an especially active season at the Government and Marine Biological Laboratories at Wood's Hole. At our request Professor Peck, who

Baird's designs in the year 1884, as part of the large building which serves the department of fish culture. This is, therefore, the eleventh season during which scientific research has been prosecuted under these conditions both by government patronage and by individual responsibility, and it is instructive to look back over these years and see how many well-known workers have been accommodated here, and of how much service these advantages have been to the learned institutions which they represent, such as Yale, Princeton, Harvard, Johns Hopkins, Columbia, and the University of Pennsylvania, besides a large number of smaller colleges both East and West.

There have been present at the Laboratory this summer thirty workers, representing twenty important educational institutions of this country, and one German university; four of these institutions are various high schools of the city of Chicago. These thirty have been engaged upon such a wide range of problems that only the more notable can be mentioned.

One piece of research, by Prof. H. V. Wilson, upon the sponges from the Gulf of California and the Galapagos Islands, collected by the U. S. steamer *Albatross*, under the direction of Professor Alexander Agassiz, has drawn our attention to the value of that side of biological work. Embryology naturally fills a large place here and two phases of it have been followed. The first, by Prof. W. Patten, deals with abnormal development in *Limulus embryos*. A certain small proportion of the eggs pass through the normal formation of the perfect embryo, only to then reverse the process and fade back to the original simple egg condition; or a double embryo may be formed, or a triple embryo in regular sequence, or one side of the embryo

has been in charge of the research work at the Government station this summer, sends to SCIENCE this informal report.

may disappear. It is expected that the singular behavior of these eggs will throw some light upon the physiology of growth in the embryos. It has been the good fortune also of another of our number, Dr. Lewis Murbach, to have obtained the eggs of the beautiful medusa *Gonionemus*, which this season has been unusually abundant in the 'eel pond.' An account of the occurrence of the adult in this locality is being prepared, while material for a very complete study of the development has also been secured. This piece of investigation is well under way and has contributed much of interest to all who have followed its progress. Interesting stages in the larval development of *Perophora* have been observed by Mr. George Lefevre, as the free swimming tadpole larva settles down to the fixed state, with loss of tail and sense organs.

Much cytological study has been directed upon the ganglion cells of the central nervous system. The center of this line of research was at the room of Dr. Ira Van Gieson, who, with his assistant, Mr. I. Strauss, made many careful preparations of the ganglia of the invertebrates, Mollusca, Tunicata, Annelida, for comparative study; while some of the clearest results were obtained from the large motor cells from the brain of the Torpedo. Neurological work in other directions has attracted several investigators, and one might mention in this connection the very successful application of the methylene blue method by Mr. J. E. Peabody to the study of the distribution of the nerve termini in the sense ampullæ of the dogfish and Torpedo. The work—originally suggested and directed by Professor H. Ayres—is tending toward important results as to the sensory or glandular nature of these characteristic structures. Altogether, including several students working under the direction of the investigators before mentioned, there have been seven of our number engaged in special study of nerves by means

of Nissl's method, the Golgi, Weigert and methylene blue methods.

Another line of research, by Dr. T. H. Montgomery, Jr., was concerned with the histology of the Nemertine worms, and has added many interesting features to the anatomy, histology and embryology of that group, especial attention having been paid this season to the development of the proboscis.

It is very encouraging to note how much of the work heretofore enumerated is definitely upon its way to publication by the authors. Some of it is already promised to leading journals; some of it will be incorporated in theses to be offered for the degree of Doctor of Philosophy at our universities, and all of it will, I believe, find its way into important and useful channels. One piece of research, by the present writer, was advanced directly under the auspices of the U. S. Fish Commission. This relates to the food of fish fry, especially of the earliest stages after the embryo becomes capable of free-swimming existence and able to take food; the nature of the food of fry of from a quarter to half an inch in length of several families is demonstrated, while the results will be published, together with previous studies upon planktonic material and the food of certain adult fishes, for the Fish Commission.

Much might be said about the students who have come to this station for their first seaside studies, who ask common questions about common things, or common questions about rare things, or sometimes rare questions about common things. Their work never grows old, is never finished, and seems more important each year than it did the year before. Inasmuch as no regular instruction is provided at the laboratory, much depends upon the careful outlines of work to be furnished students who come here alone by those who have them in charge. Great help can be given to students by fur-

nishing in advance definite ideas of what forms to select for work, how to proceed, and what to read, and, if possible, by putting the student into communication with some one who is willing to give an occasional word of advice. This help may be well given in advance at the universities and colleges from which students come, as is proved by our experience this season; much time thereby is saved for them and their work is more consistent and fruitful.

Another advantage of the presence of students who are doing work of a more general character is the custom of regular towing, and of constantly bringing into the Laboratory fresh supplies of living material of many kinds. The tow net is also drawn each day by Collector Vinal N. Edwards, of this station, and this, together with the large and beautiful aquaria in the exhibition room of the Laboratory, keeps all the men engaged in special research in association with general phenomena of the most attractive kinds.

It is very interesting also to see how much material for future work is each year taken from this Laboratory. Every research worker carefully collects all that he can to furnish his basis of study during the winter to come; every teacher secures also a collection of forms for class demonstration in the coming academic year, while some come here entirely for such general collecting. In this way biological work in all of the twenty universities, colleges and secondary schools represented here this season will derive many advantages from this station. In this connection we feel that too much cannot be said of our appreciation of the excellent collecting facilities offered here by the equipment of boats and other apparatus, nor of our grateful recognition of the invariable courtesy and coöperation of the U. S. Fish Commission authorities immediately in charge of this station.

Some of the most pleasant occasions of the summer were the informal gatherings held each Monday evening, at one of the large rooms of the 'Residence,' at which some of the older members of the Laboratory described the results of their various lines of investigation. Seven different themes of original research were thus presented, while the interest was much increased by the very general discussions and questions which followed each talk.

Altogether, this has been a very successful season at the Laboratory; there has been an earnest tone of work that has made itself felt throughout. We also owe very much to the advantages coming from our proximity to the Marine Biological Laboratory, and consider that much of our success is due to being so near to the active work of that institution.

We learn just at the closing of the season of the death of the Commissioner of Fish and Fisheries, Marshall MacDonald. Our grief is very deep at this sad news, for he was to all of us who have been associated with him a personal friend whom we loved, even as we respected his most liberal mind. His generous appreciation of all purely scientific work was a direct fulfilment of the original design of Professor Baird. Commissioner MacDonald's kindness, sympathy and personal interest in the young men working at this Laboratory will ever remain as most cherished memories by those who thus knew him.

J. I. PECK.

GEOGRAPHY AT THE BRITISH ASSOCIATION.

At the Ipswich meeting of the British Association, the Geographical Section was distinguished by the exceptionally small number of papers offered for reading, and several of those which were presented were read, contrary to the usual practice, in the absence of their authors. These facts must not be taken as implying any loss of interest

in geography on the part of the British public, but they are probably to be looked upon as an indirect result of the Geographical Congress held in London in the beginning of August which, with its surfeit of papers and discussions by the leading geographers of the world, was naturally enough felt by many geographers as sufficient for the year.

Section E met on four days, and on the average five papers were read each day, many of them being illustrated by the lantern. The proceedings were opened by an address in which Mr. H. J. Mackinder, reader in geography at the University of Oxford, as president of the Section, brought the intellectual value of geography in education into prominence. The address commenced with a comprehensive summary of the growth of modern geographical ideas from the Middle Ages down to the time when the labors of Ritter and Peschel made geography a modern science, and prepared the way for the university recognition of the subject which is now practically universal in Germany, though unknown in Britain. The geographical argument he sketched as forming a book of three chapters—geomorphology, geophysiography (comprising oceanography and climatology) and biogeography, with a supplement to the whole in the form of the history of geography.

The address embodied the practical suggestion that a centralized school of geography, guided by geographical and educational experts, should be established in London, under the immediate inspiration of the Royal Geographical Society. The concluding words express in a sentence the truth which volumes of argument seem powerless to impress upon university authorities:

“The geographical is a distinct standpoint from which to view, to analyze and to group the facts of existence, and as such entitled to rank with the theological or philosophical, the linguistic, the mathemat-

ical, the physical and the historical standpoints.”

The General Committee of the Association very appropriately appointed a committee with Mr. Mackinder as chairman and Mr. Herbertson, lecturer on geography at Owens College, Manchester, as secretary, to investigate and report upon geographical teaching in the United Kingdom.

Excellent papers on exploration were read by Mr. G. F. Scott Elliott on a journey to Ruwenzori, by Captain Hinde on the Congo State, by Mr. Myers on Caria in Asia Minor, by Mr. Borchgrevink on the Antarctic regions, and for Mr. Bent on southern Arabia; but the facts treated of had already been made public.

New results in travel were communicated by Mr. H. S. Cowper, who had made an interesting journey through Tarhuna and Gharian, in Tripoli, in bringing home photographs of many important sites previously little known, and by the Rev. W. Weston on the Japanese Alps, with an account of the curious rites practiced by the Japanese pilgrims on their visits to the mountain shrines.

Lengthened experience of a little-known land enabled Mr. John Dodd to give a paper of very high geographical value on Formosa, an island which he probably knows better than any other European, on account of his long residence there and his trading journeys among the aborigines of the interior. Dr. A. Markoff gave an account, from Russian official sources, of the conditions of the Asiatic dominions of that empire, and the probable effects of the completion of the trans-Siberian railway now in course of construction.

Mr. Montefiore, secretary of the Jackson-Harmsworth Arctic expedition, reported the return of the yacht ‘Windward’ from Franz-Josef Land, where she had wintered after landing Mr. Jackson and his party. Mr. Jackson started for his journey toward

the pole in March, returning twice to his base for supplies to equip the advanced station, where he will spend the coming winter; but the 'Windward' only broke out of the ice on September 7th, and her crew suffered badly from scurvy.

Major Leonard Darwin read a report on the Sixth International Congress and sketched the work done at that gathering.

In some respects the most valuable papers submitted were those dealing from the geographical standpoint with various special sciences. Astronomical geography was represented by Mr. W. B. Blaikie's remarkably ingenious Cosmosphere, a union of the terrestrial and celestial globes on which all problems in practical geography could not only be worked out, but demonstrated directly to the eye.

Oceanography had as its exponent the first British authority, and probably the first authority in the world, on the whole subject, Dr. John Murray, who discoursed on the general circulation of the oceans. Mr. H. N. Dickson demonstrated, by a series of exceptionally fine lantern slides, the results of his recent discussion of observations made on the conditions of the North Atlantic, bringing out the close relation between the axis of relatively high water temperature in the ocean and the position of the North Atlantic anti-cyclone, by which the climate of Europe is largely conditioned.

In climatology M. Ravenstein presented the report of a Committee of the Section on the investigation of the climate of tropical Africa by means of instruments supplied by the Association and employed by government officials, missionaries and traders in various parts of the continent. Biological geography was well represented by Mr. A. Trevor-Battye, who, in the course of a paper on the 'Struggle for Existence under Arctic Conditions,' insisted on the probability of the theory of instinctive return to an ancestral home being the compelling power in

the northern migration of birds for the breeding season.

And in history Mr. Myers succeeded in making clear the geographical conceptions of Herodotus by reconstructing, from the writings of the 'Father of History,' maps such as might have been used in the first discussion of these views.

HUGH ROBERT MILL,

LONDON.

Recorder of Section E.

SCIENTIFIC NOTES AND NEWS.

THE SMITHSONIAN EXHIBIT AT ATLANTA.

THE Government building at the Cotton States Exposition contains collections of great interest exhibited by the Smithsonian Institution and the National Museum. According to the pamphlet published to accompany the exhibit an attempt has been made:

1. To give as good an idea as possible of the character of the treasures which are preserved in the Museum, by presenting an epitome of its contents, with contributions from every department.

2. To illustrate the methods by which science controls, classifies and studies great accumulations of material objects, and uses these as a means for the discovery of truth.

3. To exhibit the manner in which collections are arranged, labeled and displayed in a great museum.

4. To afford as much instruction and pleasure as possible to those who may visit the Atlanta Exposition, to impress them with the value of museums as agencies for public enlightenment, and thus to encourage the formation of public museums in the cities of the South.

These objects seem to be admirably accomplished by the collections which are exhibited under the following departments: *Mammals*, including, in addition to 43 specimens illustrating range and classification, 12 of the most characteristic types of the human species. *Birds*, represented in their natural surroundings. *Reptiles*, showing the poisonous snakes of the United States. *Fishes*, including 73 of the most characteristic species. *Comparative Anatomy*, arranged by Mr. F. A. Lucas, is intended to illustrate

the structure of a considerable number of the most interesting types of the animal kingdom. *Marine Invertebrates*, in part, a continuation of the Department of Comparative Anatomy. *Mollusks*, arranged by Mr. C. T. Simpson. *Insects*, selected from the rich entomological collections of the Museum by the late Prof. C. V. Riley. *Paleontology*, including 116 species of North American fossils. *Geology*, exhibiting the occurrence of gold and silver in nature. *Minerals*, representing chemical and physical relations. *Botany* and *Materia Medica*. *Prehistoric Anthropology* and an alcove exhibiting the origin and significance of games. *Arts and Industries* and *Technology*, with special reference to industrial development. Ethnology offers exhibits of special interest, in part from the Bureau of American Ethnology prepared under the direction of Dr. W. J. McGee, and in part from the Department of Ethnology selected by Prof. O. T. Mason.

AN account of the Smithsonian Institution, its origin, history, objects and achievements, has been prepared by Dr. G. Brown Goode, intended to accompany the collective exhibit of the Smithsonian Institution and its dependencies at Atlanta. This should be read not only by visitors to the Exposition, but also by all who are interested in the Smithsonian Institution and the advancement of science in America. Dr. Goode concludes the article with the following paragraphs:

At the time of the Smithsonian bequest the endowment of research had scarcely been attempted in America. There were schools and colleges in which science was taught, and certain of the teachers employed in these institutions were engaged in original investigation. There were a few young and struggling scientific societies, very limited in extent and influence, but at that time the chief outcome of American scientific work. Science in America was an in-

fant in swaddling clothes. Fifty years have passed and American science now stands by the side of the science of Great Britain, of Germany, of France, a fellow worker, competing on an equal footing in nearly every field of research.

The Smithsonian Institution did what was, at the time of its organization, absolutely indispensable to the rapid and symmetrical development of American scientific institutions, and but for it science in America would no doubt have advanced with much less rapidity. It is also certain that the progress of American science has had an immense influence upon the welfare of America in every department of intellectual and industrial activity and a reflex action upon the scientific and industrial progress of the entire world.

In 1896 the Smithsonian Institution will celebrate the end of its first half century. A special volume will be published to commemorate the event, and two memorial tablets will be erected in honor of the founder in the city of Genoa, where he died, June 26, 1829; one in the English church, and one upon his tomb in the beautiful little English cemetery on the heights of San Benigno.

It is interesting to remember that in September, 1896, will occur not only the semi-centenary anniversary of the birth of the Institution founded in the City of Washington by Smithson, but also the centenary of the delivery of that immortal address in which Washington so forcibly recommended to his countrymen to promote as an object of the highest importance institutions for the increase and diffusion of knowledge.

GENERAL.

READERS OF SCIENCE will remember criticisms made in the journal (June 21, 1895, p. 682) regarding the illustrations in *The Standard Natural History*. The full bench of the Supreme Court of the State of Massa-

chusetts made a decision on October 19, which concerns the matter, and is of much scientific importance. Action was brought by Herman Julius Meyer, of Leipsic, publisher of Brehm's *Thierleben* against Estes & Lauriat, and S. E. Cassino & Co., for the breach of a contract made by them with the plaintiff in 1883, for the sale of plates to publish a natural history. By the terms of the contract the defendants were not to sell or dispose of the plates. It was for a breach of this provision that this suit was brought. The plaintiff claimed to be entitled to recover a \$30,000 penalty, as provided in the agreement, for a breach of the contract, as well as damages for the breach. The Judge at the trial in the Superior Court held that he was not entitled to recover. The decision now given holds that the plaintiff cannot recover the amount of the penalty, but is entitled to compensation for the breach of the agreement in disposing of the plates.

PROF. G. MACLOSIE, of Princeton, has published in the October number of the *Bulletin of the Torrey Botanical Club* an article on 'Antidromy in Plants,' previously read before the Botanical Section of the American Association. The author reports the discovery that all species of Phænogams appear to have two castes of individual plants, born of the same mother-plant, and differing by being slightly curved in opposite directions. Phyllotaxy is only one of the manifestations of this: and all plants seem to have heterodromous phyllotaxy between the different individuals of a species, and homodromous phyllotaxy within an individual and with all the quasi-individuals produced from it by cuttings or bulbs. Thus half the members of a species are 'antidromous' with the other half, the difference apparently arising from their being derived from seeds borne on opposite margins of a carpellary phyllome. In some cases plants derived from the same root-stock, as Iris,

Colla-lily and Rush, are relatively antidromous. Antidromy is a primitive character, affecting mother-seed, embryo, stem, leaves and inflorescence. It is frequently disguised and concealed by secondary changes, as twining of stems and contortions of flowers, spreading out and opposition of leaves. It affords a ready solution of puzzling problems, and is useful in suggesting new problems and new lines of discovery.

THE Huxley Memorial Committee is expected to take prompt action in the matter of organizing an American Committee. The latest reports from Professor Howe indicate that substantially all the American scientific men who have been thought of as possibly willing to serve have, so far as approached, signified their willingness to do what they can in the matter. The biologists are likely to be well represented, particularly, and the leaders in scientific work in every field will do their full share. It is hoped and anticipated that the contributions from the United States will rival those of Great Britain and exceed those of any other nation.

At a meeting of the Graduate Students' Association of the Johns Hopkins University, on October 11th, brief addresses were announced by Professor Brooks, on 'Huxley;' by Professor Rowland, on 'Helmholz;' by Professor Welch, on 'Pasteur,' and by President Gilman, on 'Dana.'

Nature states that a commission has been appointed charged with undertaking a systematic geological survey of Cape Colony. The commission intends to prepare at once a bibliography of all previous publications relating to the geology of the Colony.

THE late Professor Babington, of Cambridge, bequeathed to the University his entire collection of plants. His botanical library was presented to the University in 1888.

PROFESSOR E. E. BARNARD, of the Lick Observatory, has removed to Chicago, although the Yerkes Observatory will not be ready for use during the coming year.

PROFESSOR RAOULT, of Grenoble, has been awarded, for his chemical researches, the biennial prize (20,000 fr.) of the French Institute.

A FORMULA occurring in the account of Dr. Artemus Martin's paper read before the American Mathematical Society appears in SCIENCE, No. 39, Sept. 27, 1895, p. 395, as

$$z=(p^2+q^2)(r^2+s^2), \pm 2rs(p^2-q^2),$$

instead of

$$z=(p^2+q^2)(r^2+s^2) \pm 2rs(p^2-q^2)$$

DR. ROBERT BELL, assistant director of the Dominion Geological Survey, states that he has discovered a river larger than any other stream in the province of Quebec, together with a great area of timber land and a country suitable for agricultural purposes. This new river, for which the Indians have no name, is larger than the Ottawa, and Dr. Bell affirms it to be the sixth of the great rivers of the world. Its average width is considerably over a mile, and it has expansions many miles in width. It flows through a level country and is very deep. The river is five hundred miles in length, and would be navigable for steamers until toward James Bay, where there are great rapids.

DR. EDWARD W. BEMIS, lately professor in the University of Chicago, has become associate editor of the *Bibliotheca Sacra*, giving especial attention to applied ethics, economics and civics.

ACCORDING to the New York *Evening Post*, Prince Henry, of Orleans, in a letter to the Société de Géographie, gives an account of his journey from Mong-tse to Ta-li-fu. In this hitherto unexplored country, 750 miles in length, he has taken 500 photographs and collected 300 zoölogical specimens. He will return to France next January.

THE Roxburghe Press, London, is about to issue the *Nursing World and Hospital Record*, a journal for trained nurses, who, it is calculated, number nearly 30,000 in Great Britain alone.

BANGS & Co., New York, announce the sale of the library of the late William Berrian, including many scientific works.

SPON & CHAMBERLAIN announce 'Polyphase and Electric Currents and Alternate Current Motors,' by Professor Silvanus P. Thompson. The subject is dealt with under the following divisions: Generators for Polyphase Currents; the Properties of the Rotatory Magnetic Field, with some account of its historical development; the Theory, Construction and Performance of Polyphase Motors; the Theory and Construction of Motors operated by ordinary single-phase Alternate Currents; together with some account of Polyphase Transformers, and of the measurements of power in polyphase systems. The same publishers announce an elementary text-book on 'Steam Engines and Boilers,' by Prof. J. H. Kinealy, of Washington University.

At the International Congress of Otolology held recently in Florence many papers were presented, but they nearly all belonged to clinical medicine. The Sixth Congress will be held in London in 1899.

It is reported that petroleum wells in Java are very productive and are becoming important commercially.

THE English Consul in St. Paul de Loanda reports that the Trans-African Railway is now open for a distance of 300 km. and will be continued to Ambaca.

MR. FRANKLIN L. POPE, known for his contributions to electrical science, was killed on October 13th (æet 66), from electrical shock while examining the connections in his own house. In 1870 Mr. Pope invented with Mr. Edison the one-wire printing telegraph, and in 1872 he invented the rail

circuit for automatically controlling block signals, a patent largely in use on the principal American railroads. He was also the author of the 'Electric Telegraph' and 'Life and Work of Joseph Henry,' and was for several years editor of the *Electrical Engineer*. In 1885 he was elected president of the American Institute of Electrical Engineers.

UNIVERSITY AND EDUCATIONAL NEWS.

THE Stanford estate has just won its second victory in the suit of the Government to recover \$15,000,000 from its funds. A demurrer by the attorneys for the estate, alleging want of equity was sustained by United States Circuit Judge Ross, and this decision was sustained by the United States Circuit Court of Appeals, Judges Gilbert, Hawley and Morrow. The case goes to the Supreme Court for final decision, but it is felt that this decision must be in favor of the estate. The interest in the matter arises from the fact that this money was intended by Senator Stanford as the ultimate endowment of Leland Stanford, Jr., University, and the establishment of the Government's claim would seriously cripple the future of the University.

THE British Treasury has decided that the annual grant of which King's College, London, was deprived under the late Government may be restored to the College next year without any stipulation as regards tests.

ABERDARE-HALL, Cardiff, founded in 1885 in connection with the South Wales University at Cardiff, for the training of women students, has now been formally dedicated.

THE registration in the freshman class of the University of Minnesota at the present time has reached a total of 628. This number is distributed as follows: College of Science, Literature and the Arts, Classical 43, Scientific 126, Literary 114, Teachers' 25—308 in all; College of Engineering, Met-

allurgy and the Mechanic Arts, all courses 64; College of Agriculture, 4; College of Law, 107; Colleges of Medicine, Medicine and Surgery 71, Homeopathic Medicine and Surgery 8, Dentistry 48, Pharmacy 18.

The Faculty of the College of Engineering, Metallurgy and the Mechanic Arts, University of Minnesota has recently been strengthened by the addition of two men; Frank H. Constant, assistant professor of structural engineering, comes from the Osborn Company, Civil Engineers, Cleveland, where he held the position of assistant engineer and obtained a wide experience in designing and constructing bridges, roofs, elevated railroad tracks and other structures. Between graduation and joining Frank C. Osborn in the above named company he was in the employ of the King Bridge Company. Mr. Constant graduated with distinction at the University of Cincinnati in 1891, after taking his mathematical and professional training under Henry T. Eddy and Ward Baldwin. H. Wade Hibbard, assistant professor of machine design, is a graduate of Brown University and Sibley College, Cornell University, where he won high distinction. After graduating from the last named institution he entered the employ of the Pennsylvania Railroad Company and remained with the chief mechanical engineer of that system for three years, directing construction and repair in the Juniata shops, going to England and the Continent to investigate railway practice and performing other responsible duties. At the end of that time Mr. Hibbard was secured by the Lehigh Valley Railroad as chief draughtsman, which responsible position he held until his call to Minnesota.

It is stated that Birmingham is spending £50,000 on a central technical institution; Manchester, £130,000; Salford, £55,000; West Ham, in the East of London,

£40,000; Wigan, St. Helen's and Derby, £20,000 each; whilst Liverpool is having plans prepared which contemplated an outlay of £80,000.

DR. F. DIMMER, of Vienna, has been appointed to the chair of ophthalmology at Innsbruck in succession to Dr. Czermak.

THE University of Texas has opened its twelfth annual session with about 225 students.

THE report of a committee consisting of Lord Playfair, Lord Welby and Sir M. W. Ridley, M.P., appointed to consider the desirability of a fixed age for the compulsory retirement of professors under the crown has been published as a Parliamentary paper. The principal conclusions arrived at by the committee are that there should be fixed rules as to superannuation of presidents and professors, and that they should be made by college statutes and not by an Order in Council. When a professor reaches 65 years of age the president of the college should be bound to report to the government the condition and efficiency of the teaching. If these are and continue to be satisfactory, the professor need not be superannuated till 70, but at this age his retirement should be absolute. In regard to presidents, the committee is of the opinion that the age of 70 should be the period of retirement, but, should the visitors of the college formally report that the college would suffer by the loss of the experience which the president has acquired, the Treasury, and not the Irish office, should have power to continue him as president for a certain number of years not exceeding five, so that at the age of 75 the retirement of a president should be absolute.

CORRESPONDENCE.

A FEW MORE WORDS IN REGARD TO THE NEW BIBLIOGRAPHICAL BUREAU.

IN SCIENCE for August 23d I took the liberty of explaining, in a brief way, some of the

principal features of the new Bibliographical Bureau for Zoölogy. I was not, however, able to compare the system adopted with the numerous suggestions which had been made in this journal by correspondents interested in this important question. I shall now attempt to do so as briefly as possible.

In the first place, let me state that the work will agree closely with the propositions formulated by the Harvard Faculty. In elaborating this plan, I have been obliged to travel to almost every country of Europe, and to consult several hundred zoölogists and bibliographers from all parts of the world. It seems, therefore, a very significant fact that these two independent plans should show such striking similarity. This circumstance seems to show most conclusively that there is a real want felt for just such an organization of the service.

The features in which we differ from the plan of Professor Bowditch (not counting those where we simply go farther) are the two following: (1) The greater centralization of the work. We did not want to depend upon the coöperation of the authors. Our arrangement does not exclude the other. If the authors can be induced to aid us it would be a great saving, but we must be able to get along without their direct aid. (2) The notes appended to the titles by the Bureau are not intended to be *résumés*, but are to be concise statements of the *topics treated*. To make a *résumé* requires too special knowledge on the part of the bibliographer for it to seem practicable. This is the province of the Zoölogical Record and of the 'Jahresbericht,' and it is best not to duplicate their work.

In Professor Hale's letter I was much interested in his idea of a 'Bureau of Scientific Correspondence.' This is almost exactly what we shall offer. I differ from your correspondent merely in the minor point of not fancying a restriction in the matter of language to English and French.

The bibliographical part of Professor Todd's scheme corresponds too obviously with our own to need special comment. The same is true in regard to Dr. McGee. I should, however, like to call attention to his remarks on non-commercial

publishers. It is the basis of the coöperation that we ask.

Dr. Goode's letter reads almost like an introduction to our prospectus. I shall take up his numbered paragraphs successively and note the differences, where there are any. (1) The catalogue to be international, bearing the imprint of no society or organization; the same language to be used in the notes added as in the original, no restriction to English and French; Slavonic, Scandinavian and Oriental titles to be translated into French, German or English. The only way in which this would differ from our decision relates to the Scandinavian languages, these being kept in the original just as Italian or Spanish. (2) I fear that Dr. Goode would set a higher standard of comprehensiveness than we have done. (3) Dr. Goode chooses in favor of an annual form of publication, while our Bulletin will be fortnightly. The morphological titles will, however, be reprinted in the 'Jahresbericht,' so that this requirement can in part be met. It is possible that provision may ultimately be made for similarly bringing together the systematic part. (4) The annual lists would be indexed alphabetically under authors' names, as suggested; and, for cross reference, the year, the author's name and the running number will be used. A 'pasting' edition is also called for in the adopted regulations. In regard to the suggestion that the Mährenthaler typesetter be used for this work, it may be of interest to note that this has proved impossible; the company does not recommend its machine for broken work in which several faces of type are necessary. The remaining sections of the letter relate principally to the comprehensive scheme of a complete catalogue of science. They can, in my opinion, best be attained by the creation of federated bureaus for the branches. In this way it is possible to adapt the system to the special needs of each science, and yet to have the entire field adequately covered, as desired by the Royal Society. The criticism which Dr. Goode makes of the card system seems to be fully justified. It is a bulky contrivance, and, while it is doubtless indispensable to the worker and to libraries, yet it cannot wholly supplant other forms of publication. The New Bureau will combine both

methods, using the same type to print the several editions.

Mr. Weeks has also very fairly indicated the limitations of the card catalogue, and makes many of the same suggestions as Dr. Goode. I fancy that our Bureau would meet the needs set forth by Mr. Ramsay, each person being able to arrange his cards as he might see fit.

Finally, I find the methods of the Bureau in substantial agreement with the methods of Dr. Josephson, except that his 'Bureau for Natural and Physical Science' seems too little specialized.

In conclusion, let me refer to certain modifications of the system, which have been proposed in articles in other periodicals, or in personal letters to me or to one of the National Committees. In an interesting Russian note advocating the new Bureau, Prof. Mitrophanov suggests that a larger part of the work be left to National Bureaus. This step has not seemed wise for the reason that the work could not be uniformly done unless centralized.

Prof. Nachtrieb, who has been kind enough to abandon a similar enterprise in order not to conflict with our own, urges the adoption of descriptive words in place of the symbols which it is proposed to use; and a similar suggestion is made in an Italian article which I have received from Prof. Camerano. I think that these critics do not realize the fact that these symbols will often be very numerous, and that they are to be used in classifying the card when received rather than in consulting the catalogue. It is undoubtedly easier to run through a package of cards in search of the number 7 than to read each word in search of a long polysyllable; but when the cards are once classed, there is no need of even doing this; the guide cards would then be used. It must be remembered that it is not necessary to use these symbols save when they are needed, *i. e.*, in having the cards put in place by a person unfamiliar with the science. In fact this has been a feature which has been especially recommended by a number of persons. Mr. Dewey and Mr. Peckman Mann have gone still further in this direction and have urged the adoption of the 'Dewey System.' It remains to be seen whether this system would not become too complicated when applied to the

several cross classifications which we shall have to employ. It will also be necessary to see whether these symbols cannot be placed in a less conspicuous place on the cards. This is not so easy as would at first appear, for it must be remembered that the same type must be used for the pamphlet edition.

I have now passed the more important notes in review, hoping that this may facilitate future correspondence. Permit me to state, in closing, that I should be delighted to receive further suggestions in this regard. I must beg, however, some indulgence if I should find myself unable to reply promptly to all friends of the undertaking; the correspondence has already assumed such proportions that it is almost impossible to attend to it single-handed.

HERBERT HAVILAND FIELD.

THE DOGMATISM OF SCIENCE.

TO THE EDITOR OF SCIENCE—*Sir*: "The hardest of intellectual virtues is philosophic doubt," it has been said, and viewing the statements and the facts, one is inclined sometimes to assent to it in a literal way, *i. e.*, as an unintentional statement of the hardness, density or impenetrability of much that passes under the name of philosophic doubt. By the words, however, it is supposably meant that this 'philosophic doubt' is a virtue above all others, and that it is only the extremely virtuous who may ever reach this lofty pinnacle of greatness. To this I demur. As Heine said: We are natural protestants, and certainly the spirit that denies, *der Geist der stets verneint*, is as a matter of fact the easiest and the most common of 'virtues,' though Goethe and humanity have agreed in personalizing it as distinctly Mephistophelean, rather than angelic, or even manly. I should add that "the mental vice to which we are most prone is our tendency to assume that" our *Verneinung* in the name of science of all the religious and poetical truths that have been gained by humanity has anything virtuous or logical or scientific about it.

As to what is virtue, intellectual or moral, and as to what may be logical, there will never be an end of discussion, but as to what is scientific there should nowadays be convictions so indubitable that discussion should end. Even

the typical scientific dogmatist must admit that science properly considered is the unprejudiced, colorless observation of facts and the inductions from these facts *only so far as the facts will carry*. But the fundamental thesis of a certain class of scientists is that biologic facts are all explainable by the forces of 'mechanical energy and physical matter.' To ordinary—what I should call normal or healthy—minds, this is as perfect an example of deduction, theory or dogmatism as could be stated. So long as the old materialistic bauble of spontaneous generation remains the veriest will-o-the-wisp, the most undemonstrated and undemonstrable absurdity, so long have these 'scientists' not a shred or shadow of evidence that their dogma has any genuine scientific basis. For every biologic fact there must be posited the unexplained, and so far in-explainable fact of life itself, of sentience, or 'sensitive' or 'irritable' protoplasm, as the very beginning of the fact. To say in advance that this life, sensitiveness, irritability, etc., is explainable upon the principles or forces of physics is in most absolute contradiction of the scientific spirit, and one who dogmatically asserts it has yet to learn the a b c of scientific method. The scientist who thus commits scientific suicide may charitably be excused on the ground that he is a victim of the subtle laws of psychologic heredity, that he is an 18th century atheist masquerading as scientist, one with a dissident dogma unwarrantably compelling science to a service from which she must instinctively rebel.

In a recent letter to SCIENCE Professor Brooks pathetically pleads for a united front of all scientists against the 'Vitalists,' and that the 'dogmatism of biologists' must be attacked at both ends of the line. This rallying cry for unanimity of utterance rather than for adherence to personal conviction is sadly suggestive. It would seem that a more 'virtuous' ideal would be that of following truth rather than partisanship. 'Failure to agree' is stigmatized, but it might be politic to first ask who are the disagreeers. The answer to that question might result in the finding that Professor Brooks and his party are the disagreeers or sectarians, because if my observation is correct the scorned vitalists, as Professor Gage avers, constitute the

immense majority of scientific workers, and the few materialists who presume to speak in the name of their scientific brethren have no brief so to represent them. The cool assumption that biologic science is coterminous with physics is difficult to correctly characterize—politely. The refutation of that dogma has been made a hundred times and no adequate answer to these refutations has ever been made. Take one of these refutations, Beale's *Protoplasm*; no dispassionate and logical mind, knowing aught of the history of science or the laws of logic, can deny that the arguments and facts there set forth leave the dogmas of scientific materialism smashed to utter and everlasting smithereens.

An amusing corollary of the scientific dogmatists is that "consciousness and volition cannot cause structure or anything else," and that function is always the result of structure. This is, of course, necessary to the materialistic dogma, but "it can be stated without fear of refutation" that no one, not even Professor Brooks, ever observed a single fact of physiology, plant or animal, in which function did not precede structure, and surely before he could write his denial his 'consciousness and volition' set to work the machinery that moved his pen. Are the pseudopods of the amœba 'structures'? Did not the function of amœboid locomotion precede the locomotion of truly structural organs, such as feet and fins? Did not the desire for movement precede amœboid movement? Did not the desire create the structureless pseudopods? If function is always the result of structure, what then created the structures, *e. g.*, the million structures of the unborn fetus? The logic of the situation is that as 'consciousness and volition' have no organs, so far as any scientist knows, of which they are the outcome, it follows that consciousness and volition are only 'the empty shadow of changes that go on in the physical basis'—*i. e.*, they do not exist. If the facts do not tally with our theory so much the worse for the facts—let's flatly deny them existence. Of 'beliefs held because they cannot be disproved,' the most perfect of illustrators are surely those children in science who dogmatically wage Quixotic warfare against dogmatism.

Of the many charming self-contradictions of

Professor Brooks' delightful letter that I should like to mention, none is more suggestive than his 'demand' that we accept as our sole scientific creed the desire to find out "whether life is or is not different from matter," and "whether thought is or is not an agent," and yet the beginning, middle and end of his entire letter is, one might say, soaked in the dogma, determined in advance, that there is no 'whether' at all, and that it 'is flatly contradicted by most investigators.' His contempt for those who still entertain the 'whether' is,—to put it most courteously—the limit of childish *naïveté*.

GEORGE M. GOULD.

PHILADELPHIA, October 15, 1895.

THE INVERTED IMAGE ON THE RETINA AGAIN.

PROFESSOR BROOKS' statement concerning the inverted image on the retina, in a late number of SCIENCE, has called to my mind an experiment in optics which I stumbled upon as a boy one Sunday night in church when the sermon had extended beyond my powers of listening. As I have not seen an account of the experiment in the usual statements regarding the demonstration of the inverted image on the retina, I venture to give the matter for whatever it may be worth.

My attention having been attracted by the 'beams' of light which seemed to shoot off towards the ceiling and toward the floor from one of the gas jets of a chandelier, I aimlessly pushed against the *under* eyelid with my finger, and was surprised to see one of the beams of light, the *upper* one, shorten and lengthen, according to whether I opened or shut the lower lid. On repeating the experiment with the *upper* lid, I obtained the same results on the beam which appeared to pass *downward* from the gas jet. By closing one eye and carefully squinting with the other at the distant gas jet and working my eyelids in the manner above described, it was at once evident that the outer termini of these beams were cut squarely off, and that the end farthest from the gas light was in some way by refraction hinged to the edge of my eyelid. In short, as these red 'rays' formed part of the opposite sides of a cone, with the gas light at their apex, and the base at the contact of the edge of my eyelids

upon the cornea, it was evident that the whole phenomenon, gas light included, was in my eye so far as sight was concerned. In short, since, when a movement of the lower lid lengthens or shortens the 'rays' which appear to shoot upward toward the ceiling, and a movement of the upper lid *vice versa*, one can see that the image in his eye is inverted, because the sides of this cone and the background of the room are reversed.

If one will work this experiment to the point of perceiving that the picture of the outside world is entirely in his eye, he may come, as I did, to the fearful demonstration that even in 'full light' outside of his eye all is in a certain sense total darkness. It is a dreadful momentary concept, more dejecting than the fear which attends the coming on of blindness from destroyed vision. J. B. WOODWORTH.

CAMBRIDGE, MASS., October 12, 1895.

It follows from Mr. Woodworth's observation that the image on the retina is inverted. The 'rays of light' are not, of course, objective; but are due to imperfect accommodation. The light from a gas jet passing through the lower half of the pupil is in part refracted downward, affects the lower half of the retina, and is projected as rays extending upward. The same inference can be drawn from an examination of *Purkinje's figures* (the blood vessels of the retina), subjectively and objectively; or, indeed, by pushing the eyeball upward, in which case objects seem to move downward.

It is commonly believed that the external world sends up through the nerves little images of itself which are examined by the mind. This seems to the present writer a 'dejecting concept.' *Per contra*, the fact that the world in which we live is a mental construction assigns to mind its due place in the universe.

J. McK. C.

'CRYING WITH TWO EARS.'

IN SCIENCE for October 11th (page 487), Professor J. McK. C. corrects an inaccuracy in Professor Brooks' statement concerning the inverted image. He closes his criticism with the paragraph: "A similar paradox is the fact that with two images on the retinas we see things singly. This may also be treated without undue

seriousness by the question: 'If we hear a baby crying with two ears, why do we not think it is twins?'" What terrible sort of baby is it that cries with two ears? I protest against such a little monster. Is it not sufficient that a baby cry with one throat, and that we hear it with two ears? And are there not times when we think it is triplets? W. H. FISHBURN.

SECOND PRESBYTERIAN CHURCH,
COLUMBUS, O., October 12th, 1895.

INACCURATE ZOÖLOGY.

THE EDITOR OF SCIENCE—*Sir*: It appears to me that zoölogists should endeavor, whether for their own good or that of the science they cultivate, to see that popular zoölogical works are prepared by zoölogists, instead of being compiled by persons comparatively ignorant of the subject. Perhaps the most effectual means to this end consists in pointing out the inaccuracies of works which have not been written with sufficient knowledge, so that the public may be more careful about what it accepts. No one appreciates more than the present writer the great difficulty of ensuring perfect accuracy, and it is not suggested that those who might be criticised have not done the best in their power; the point is, rather, that the services of specialists should in every case have been secured.

Even so, curious errors will sometimes appear; perhaps usually due to the writer trying to cover too much ground. Thus in the *Standard Natural History* there is a figure of a *Pulvinaria*, called '*Coccus adonidum*;' this latter name belonging really neither to a *Coccus* (as now understood) nor a *Pulvinaria*, but a *Dactylopius*!

A few days ago the new *Standard Dictionary of the English Language* (Funk & Wagnalls Co., 1895) was received, and on looking over it I at once stumbled on the following curious items:

- (1.) The cotton scale-insect is 'a bark-louse (*Pulvinaria innumerabilis*).' There is no recognized cotton scale-insect in this country, though there are scale-insects which affect cotton. *Pulvinaria innumerabilis* is not a cotton species, but affects maples in the North. *Cottony* scale is doubtless what was intended.

- (2.) Coccidæ have scale-like *larvæ* and live in plants.
- (3.) A picture of a snail shows a sinistral shell, so also does the figure of *Linnaea stagnalis*. The snail is labelled *Helix pomatia*, but the figure appears to represent *Helix aspersa*.

And so on in other cases, although the bulk of the zoological information seems correct.

This morning was brought to me a little book which the New Mexico Territorial Board of Education have under their consideration for adoption in the High Schools. It is called *Zoology for High Schools and Academies*. (American Book Company, 1895, pp. 216.) The authoress is Margaretta Burnet. I could not very well recommend its use, after reading in it such things as the following:

- (1.) p. 90. Scale insects belong to Aphididæ.
- (2.) p. 132. Daddy longlegs is an example of the Scorpions.
- (3.) p. 59. Figures of three 'Fresh water snail-shells.' The middle figure is a *Succinea*. On p. 56 a *Succinea* is correctly figured as a land snail.

Yours truly,

THEO. D. A. COCKERELL.

MESSILLA PARK, NEW MEXICO.

SCIENTIFIC LITERATURE.

Allgemeine Physiologie. Ein Grundriss der Lehre vom Leben. Von MAX VERWORN. Mit 270 Abbildungen. Jena, Gustav Fischer. 8vo. Pp. xi., 584.

This work is a very acceptable addition to the series of biological text-books issued by Fischer of Jena, and takes its place worthily. In size and general appearance it conforms to the model adopted by the same publisher for Hertwig's Embryology, Wiedersheim's Comparative Anatomy, Ziegler's Pathology, and other familiar authoritative and important manuals.

Verworn attempts to present a summary of principles of physiology applicable to both plants and animals generally. He covers, therefore, somewhat the same ground as Claude Bernard in his classic work of 'Les Phénomènes de la

Vie communes aux Plantes et aux Animaux.' But whereas the French physiologist included much original research in his work, his German successor gives rather a collation of the results hitherto attained. It is certainly unfortunate that 'General Physiology' has been treated as a stepchild of Biology and left pretty much to shift for herself. Verworn renders, therefore, a substantial service in his book by directing attention rightly, and at the same time presenting many aspects of the subject in so comprehensive a manner as greatly to facilitate the further pursuit of this neglected branch of biological science. Such an attempt, when first made, must necessarily be partially successful at the best, because the material to be brought together is scattered in a great variety of memoirs, and occurs often as an incidental part of researches upon some problem of special physiology, vegetable or animal.

We must judge such a work by what it contains, not by what it omits. The first chapter, which occupies nearly sixty pages, seems to me inappropriate, and not to add to the scientific usefulness of the whole. It deals with 'the ways and means of physiological investigation,' according to the title chosen for it by the author. But ways and means do not signify to him practical methods, but rather a series of philosophical and metaphysical concepts, which appear to me neither very profound nor original, and which certainly lack any obvious bearing on the rest of the work. The chapter, however, includes a brief historical review of the progress of physiology. This review is well done.

The remaining chapters are properly physiological; their titles will indicate their chapters:

Chapter II. On the living substance.

Chapter III. On the elementary phenomena of life.

Chapter IV. On the general conditions of life.

Chapter V. On stimuli and their action.

Chapter VI. On the mechanism of life.

In each chapter will be found many facts collated, such as one cannot readily find elsewhere brought into mutual relations. For example, in Chapter IV. there are considered the present conditions of life in the world, the origin of life on the earth and the history of death, and in Chapter V. the general nature of stimuli, and

the effects of stimulation on the cell, including chemical, mechanical, photic, electric irritations, with discussions of chemotropic, barotropic, heliotropic, thermotropic and galvanotropic phenomena, and also sections on fatigue and exhaustion.

The author shows throughout that he has received a sound scientific training, that he has a good grasp of his subject since he handles all its themes firmly and successfully, so that his book will be found very useful to those who in their teaching wish to give due prominence to the fundamental principles of biology.

In another edition there will be many changes and additions to make, which will improve the work and render it a more adequate representative of the present status of general physiology. So long as the author deals with philosophical aspects of the subjects it must be deemed a serious omission not to include consciousness. We may note other omissions, such as the phenomena of senescence and growth as a function of age, an omission which is significant to me personally, owing to my having long been specially interested in senescence as a biological problem. Again, the difference between sex and sexuality is left unconsidered; the theory of the vital force as having a ferment-like effect, the causation and laws of variability, concerning which a good deal is known, and finally many minor points, which are known to this and that specialist, all suggest opportunities for improvement. None the less the book as a whole is to be commended, for it takes a great step towards bringing order in a field of science still chaotic, and it is to be hoped that it will become well known in American Laboratories.

CHARLES S. MINOT.

Ice Bound on Kolguev. By A. TREVOR-BATTYE, London, Constable. 1895. Pp. xxviii. and 458. Three maps and numerous illustrations.

The small Arctic island which forms the subject of this sketch is an interesting place, as it lies just within the Polar circle, to the north of Russia, between the entrance to the White Sea and the mouth of the River Petchora.

The two attempts which were made to colonize the island in the latter half of the eighteenth century resulted in failure; and at

the present time the Samoyede families who eke out a miserable existence there can hardly be called a successful venture in that line, because the conditions of life force them to a nomadic career, which puts an end to all development.

With regard to the structure of the island, the author was not able to find any trace of the rocky character which has usually been assigned to it. He describes the surface as one composed mainly of sandy hills, which are confined to the central and northern portions, while the southern districts are occupied by tundras of considerable extent. The soil of these tundras, frozen solid during a great part of the year, and only thawed out to a depth of a few feet at best during the summer, limits the amount of the food supply in the most thoroughgoing manner.

About 110 plants have been reported from the island and of these 95 were secured by the author. He also records 47 birds and 6 mammals.

The descriptions given in the book, particularly those of the birds and their habits and the portions devoted to the plants, are well done, and much interesting information has been put in a very agreeable form; here and there, however, one occasionally detects in the effusive style the zeal of the 'glorified naturalist.'

The volume is in the main well written, but some portions would be apt to cause the grammarians to shudder. As, for example, where we are told that "Powys kept our spirits up with the banjo, and we sang, skinned and ate many figs" (p. 52).

Our naturalist has done much painstaking work in spite of the comparatively hurried character of his trip. It is, however, to be regretted that the portions upon the Samoyedes and their manners and customs were not more carefully expanded. Enough is said to whet the appetite for more. On this island we find perhaps one of the few remaining opportunities for the study of a nearly pure form of bolvan worship; and if the author had not allowed his feelings of civilized disgust at some of the native performances to get the better of him, he might have worked himself more thoroughly into their good graces, and given us some insight into the rites of Nûm, the Arctic god. As it is, the subject is dismissed with a footnote and an ac-

count of the superstitious dread of the Russian sailors, which was produced by the knowledge that he had at least one of these 'rag dolls' on board of their vessel.

He cites the Eskimo as observers of this form of worship, but as far as they are concerned it is hardly possible that such is the case. They believe in spirits, but have not personified or individualized them in the shape of idols. The opportunities to investigate such characteristics are getting more and more rare each year, and it is a pity that any are missed.

The author has evidently not learned one of the essentials of a good explorer, and that is the ability to take things as they come. There is a sort of spirit of sad reluctance in the statement, "For breakfast we warmed our last night's lamp, pulled the wick out, and then ate the grease with black bread. It was not a *recherché* meal, but it was economical." There are instances all through the book of an evident feeling of dislike, or perhaps unrest, under the circumstances, which is hardly consonant with the best work. One is almost constrained to say that no one should venture into the field as a naturalist who is not willing to deny himself, in all matters of private convenience, for the sake of the object in view. Nothing is more apt to betray a man so quickly as an expression of his likes and dislikes.

It is to be regretted that their vessel, the Saxon, was allowed to run away with the dredges, alcohol and bottles for their work; since through this neglect they were deprived of the chance of bringing back a much larger amount of material.

There is much enjoyable reading to be found between the covers of this volume, more, perhaps, than is usually the case in books of travel. The formula for finding one's pathway after the fashion of the Cree Indian, upon pages 123 and 124, is not to be recommended to the average traveller who has strayed from his bearings. It is only the keen observer of little things who can 'shut his eyes,' think over the trail of some hours past, locate a given object and then proceed straight to it. Ordinary mortals had much better stick to their compasses, and not try to imitate the power of a genius, or even attempt to do what they have seen those who undoubtedly

possessed a large knowledge of the country do with comparative ease. The reviewer has often been through such experiences, and at first they seemed marvelous evidences of power, but later information dispelled much of the haze of glory which enveloped them. Still, we can all thank the writer for a good story well told.

A single word should be said upon the character of the illustrations. They are uniformly of a high character, and much taste has been shown in their selection. They are an ornament to the book as well as a help to the reader, and their execution is in almost every instance a credit to the designer. Of the maps, that of the island, and that showing the distribution of the ice fields about the island, are noteworthy. They are a valuable addition to our knowledge of this part of the globe, which now serves only to support the few families, who are in reality the Samoyede partners of the Russian traders from the district of Archangel.

The book is most cordially recommended to all lovers of books of travel.

WILLIAM LIBBEY, JR.

Major James Rennell and the Rise of Modern English Geography. By CLEMENTS R. MARKHAM, President of the Royal Geographical and of the Hakluyt Societies. New York, Macmillan. 1895. The Century Science Series. Pp. 232. \$1.25.

Rennell is pronounced, on the excellent authority of Markham, to be 'the first great English geographer.' He early gained an outdoor experience in a seven-year service as a midshipman in the navy, and then in 1764 was to his surprise appointed Surveyor General of Bengal at the youthful age of twenty-one. He returned to England in 1777 and resided there until his death in 1830. After completing his Bengal Atlas he turned from field surveying and became a deep student of geography, ancient and modern, of lands and of seas. It is noted that he was 'depressed by the aspect of public affairs and the wretched mismanagement of the American Revolutionary War.' It was in his later years, while a neighbor and associate of Sir Joseph Banks, that the element of attractive personality and invigorating companionship appears strongly in this biography

as in the lives of so many English men of science. Brought together in the world's metropolis, we read not so much of isolated reflections in the quiet study as of familiar intercourse in the brotherhood of congenial tastes. After the death of Banks, in 1820, Rennell was the acknowledged head of English geographers. Travellers and explorers came to him with their rough work, projects were submitted for his opinion, reports were sent to him from all parts of the world. The Raleigh Club was formed in 1827, 'for the attainment at a moderate expense, of an agreeable, friendly and rational society, formed by persons who had visited all parts of the world.' After Rennell's death the formation of a Geographical Society to supply his place became a necessity, and thus largely from his impulse was founded what has become the greatest force in geography to-day. Exploration rather than explanation was then naturally the direction of earth study; and it is chiefly in this division of geography that the English still follow their leader. W. M. D.

Oeuvres ophtalmologiques de Thomas Young, traduites et annotées par M. TSCHERNING, précédées du portrait de Young, de son éloge par François Arago et d'une préface par EMILE JAVAL. Publication faite aux frais de la Fondation Carlsberg. Copenhague, Høst et Son. 1894. 80 pp. x+248.

Among the great men who have inaugurated important epochs in science there are two classes; the first, writing with a fertile imagination and extraordinary capacity for work, have developed one or more kindred ideas and have achieved results of great perfection; the second class, while endowed with imagination no less, or perhaps even more powerful, have, in the absence of persistent, concentrated effort, followed the caprices of an intellectual curiosity which led in divers directions, and the works of their genius which have been preserved are consequently less perfect both in form and substance. Their writings are often intricate and obscure; but this very complexity not infrequently invests them with a peculiar charm for the thinker.

The most distinguished of the first type of mind was Isaac Newton; the most remarkable

of the second type was Thomas Young. Newton turned all the efforts of his genius toward mathematics and physics. To facts carefully observed he applied the powerful aid of the calculus and gave one of the finest examples of the fecundity of the mathematical method. The works of Laplace, Ampère, Cauchy and, in a certain measure, those of Fresnel are the product of a similar spirit. Works of this class are usually crowned with recognition and honors during the lifetime of their authors; for sooner or later, by the force of logic, they are able to rise above the never-failing hostile coalitions of mental inertia and the vanity of mediocrity in power. The same good fortune, however, is not the part of such works as those of Thomas Young. Mathematician, physicist, naturalist, physician, philologist and engineer, he has left profound traces of his originality in each of these domains; yet in not one of them was his genius recognized by his contemporaries. Endowed with extraordinary intuitive power, he was able to assimilate with marvellous rapidity the most varied kinds of knowledge, the consequence of which marks all his writings with a conciseness of language and exposition which, for the ordinary student accustomed to long and minute reasoning, gives to them an obscurity oftentimes discouraging.

The complications of Nature are infinite, and never in her manifold manifestations does she take into account the categories among which our intelligence is forced to divide itself up both in methods and reasoning. There is not a phenomenon in the animate world which has not its characteristics at once physico-chemical and mathematical; and the stating of biological problems in the form of problems in physics accessible to mathematical calculation is always attended with great difficulty. Young treated biological problems, especially those of ophthalmology, in this spirit, which was not then, and is not now, that of the medical profession. As a natural result he was not understood by his confrères, or was understood only sufficiently to be considered their adversary; an attitude by no means calculated to enhance his scientific popularity. He had besides the honor of being able to furnish an elegant interpretation of the curious phenomenon of the coloration of soap-bub-

bles and other thin transparent substances; also he explained phenomena not previously known, such as the shadow produced on a screen by the superposition of two luminous rays proceeding from the same source and arriving at the same point by different routes of unequal length; or, again, the augmentation of light which appears periodically when the differences of the respective routes vary. He saw that these facts were admirably explained by the hypothesis of undulations in an imponderable medium which, according to the concordance or discordance of their periods, mutually added to or destroyed each other; an hypothesis, it will be seen, diametrically opposed to that advanced by Newton. Notwithstanding his endeavor to place his idea under the patronage of his illustrious predecessor, the theory of interferences was denounced as sacrilegious by powerful adversaries, who held the public conscience and who never relinquished their hostile attitude.

But Young was 'not without honor save in his own country;' the recognition denied him in England has, thanks to a happy accident, been freely accorded in France. It was at the hands of the great Arago, himself interested in optics, that he received his first encouragement, followed by academic honors. In any case, it is in the works of Fresnel, who was inspired by the same principle, that Young's achievements were for the first time crowned with approbation; and it was the experiments of Foucault on the rapidity of the propagation of light through air and through water which gave the fatal blow to the emission theory and secured for the theory of interference a final victory. For some time past the physicists have shown a certain indifference concerning the undulatory and molecular theories, doubtless because of the superficial generalization built upon these theories twenty years ago. We cannot refuse to them, however, in spite of their hypothetical character, a marvellous rôle in discovery (as, for instance, the experiments of Herz on electrical undulation) as well as a system of representation quite satisfactory to the mind which does not seek to make a universal application. However this may be, Young has other claims to the admiration of physicists, as, for instance,

the first efforts made to unite by an empirical formula the elastic forces of vapors and their temperatures.

The works of Young in ophthalmology have not attracted the attention they merit, notwithstanding the liberal recognition of their results on the part of Helmholtz and Donders. Maxwell, Helmholtz and Rood have popularized his theory of colors which consists in attributing to the retina three kinds of fibres responding respectively to the three fundamental colors: red, green and violet; and producing by their combined impression the sensation of all the other colors; in like manner the combination of these three primary colors in variable proportions is able to produce all the appearance of colors. This hypothesis admits but a single mode of transmission of the impression through the nerves to the brain. It makes the differentiation of the sensation of color consist in a functional modification of the periphery rather than in a cerebral operation. But, while it offers a plausible explanation of certain cases of color-blindness, this theory is far from having obtained general acceptance. It seems difficult to apply it to the explanation of those cases of color-blindness where but a single color is perceived and that different from the fundamental colors of Young. But it must be admitted that Young did not advance his hypothesis without reserve, and the theories which have since undertaken to supersede his are scarcely more satisfactory; they are not susceptible of any better experimental proof nor of theoretical deductions.

A distinguished ophthalmologist, M. Tscherning, has just published a French translation of Young's works on ophthalmology with liberal commentary. The subjects therein treated appear in the following order:

1. Observations on Vision. (Philos. Trans. for 1793.)
2. A memoir 'On the Mechanism of the Eye.' (Philos. Trans. for 1801.)
3. Extracts on the vision of colors taken from different essays.
4. The 38th chapter of *Lessons on Natural Philosophy*, London, 1807: *On Vision*.
'Observations on Vision' were written at the age of twenty and present many remarkable re-

flections; take, for instance, this idea (which is developed by Chevreul in his voluminous volume *On the Law of the Simultaneous Contrast of Colors*) that those colors which, when combined, approach the nearest to white, produce, when placed side by side, the most agreeable effect. This opinion regarding the complementary colors is too absolute, as has been shown by a number of recent works; but it is a first step in the science of the harmony of colors.

The lesson 'On Vision' terminating the work is a brilliant *résumé* of the knowledge of that time, together with the writer's personal ideas on the subject of ocular dioptries, showing from the point of view of design in Nature all the advantages of the optical construction of the eye. The eye, as we know, is a sort of *camera obscura*, at the back of which is the retina. Before reaching the retina the luminous ray must pass through an *ensemble* of transparent media, which offers all the advantages of the convex lens without its inconveniences. We know, furthermore, that the luminous rays which strike the margins of the lens have their focus or point of meeting *in advance* of the focus formed by the rays which penetrate the center of the lens, to obviate which disturbing feature in photographic instruments a diaphragm is devised which cuts off the marginal rays. The iris of the eye, that membrane with its constantly contracting and expanding circular opening, placed in front of the crystalline, exercises the same function. Young shows how Nature aids still further in this direction by giving to the crystalline a gradually increased density from surface to center, thanks to which the focus of oblique rays is made almost to coincide on the entire concave surface of the retina.

The *mémoire* 'On the Mechanism of the Eye' is the most important of the work; it is remarkable for the complexity of means employed. The laws of refraction in media of uniform density had long been known; the author shows how the total index of refraction of a lens varies according to the index of refraction at the surface, when the density of the sphere or the lens varies according to the power of the distance between the surface and the center. This applies to the crystalline. He shows that the

total index of the lens is greater than the index of the center when the index, as in the case of the crystalline, is greater for the center than for the exterior. The number he got for the total index was found almost precisely correct by Mathiesen. It is in this same *mémoire* that appears for the first time a description of the *Optometer* with which Young made his principal determinations, the most complete that have ever been made of a single eye; but the instrument never came into general use and the translator was unable to find any trace of it. The principle upon which it was constructed (by Scheiner) is of a simplicity truly remarkable; a straight line down an oblong cardboard, and an ordinary visiting card perforated at one end with two pin holes, will give a fair idea of this ingenious device. By closing one eye and placing the other at the pin holes, which are held at one end of the straight line, the line in question appears no longer as a single line. To the eye looking through the pin holes two distinct lines present themselves which gradually tend one toward the other till they meet, and their point of meeting constitutes the nearest point of distinct vision. Any one may possess this simple contrivance home-made; by a system of graduation on the cardboard one may readily obtain a correct measurement of the position of the eye's focus. The experiment will show how difficult it is to fix the point where two lines cross, and the reason is that it requires considerable practice to be able to place one's eye in perfect repose, *i. e.*, to paralyze its accommodation.

Young had a large, prominent eye; which last feature he utilized with a compass to obtain an exact measurement of its length, which he found to be 23.11 mm. It was with his optometer that he discovered *astigmatism*, the unequal refracting power of the eye in different meridians; the exact degree of which he measured by the focal distance of the lens adapted to its correction. This visual defect he here speaks of for the first time, but without seeming to attach to the discovery any special importance. Young presents very complete notions on the following subjects: the field of vision; the field of perfect vision; the sensibility of the retina, less at the *fovea* than at

the periphery; on the field of regard; the fitness of the form and place of the retina for the production of a distinct image; the power of dispersion by the eye for different colors. Finally he takes up the famous problems of the mechanism which produces accommodation. To produce a distinct image of a given object on a screen the lens must be placed at a certain fixed distance from the object; how is it then that the screen known as our retina is able to receive distinct images at different distances? This problem is one not yet solved in all its complexity. The explanation offered by M. Tscherning is that the alteration required in the crystalline to form an image of objects near by is produced by the tension of the borders of the crystalline, thus increasing the convexity of the center. This is also Young's idea. Helmholtz sought to explain the alteration of the crystalline by an entirely different mechanism. Before entering upon the subject Young undertakes to eliminate the various other causes which might be invoked in elucidation of the problem. To prove that the cornea bears no part in accommodation, he neutralizes its refracting power by immersing it in water and substituting in its place a lens, and observes that there is no change in the range of his accommodation. One cannot but be struck with admiration for the patience and ingenuity which such an operation supposes. The decisive argument in favor of a change of form in the crystalline is derived by Young from a fact which Wollaston and Helmholtz sought in vain to verify, but which is verifiable on the eyes of youth, *i. e.*, the correction of the aberration during accommodation. His determination of the nature of crystalline alteration was due to another fact which has just recently been verified—that the capacity of accommodation is half as much again greater at the center of the crystalline than at its periphery; from which he concluded a flattening of the surfaces at the periphery.

It will be seen by this brief review to what an extent the ideas of Young on ophthalmology are still fresh and of absorbing interest; more than any other he has prepared the way for the final solution of these problems.

CHARLES HENRY.

PARIS.

SOCIETIES AND ACADEMIES.

THE ENTOMOLOGICAL SOCIETY OF WASHINGTON.

THE 110th regular meeting was held October 10, 1895.

Mr. Hubbard read a paper entitled 'Additional Notes upon the Insect Guests of the Florida Land Tortoise,' in which he gave his observations of the past summer, including a number of facts supplemental to his article on this subject published in *Insect Life*, Vol. VI., No. 4. The list of regular inhabitants of the burrows of the Florida land tortoise now reaches 19 species, of which 18 are insects and one is a vertebrate (*Rana œsopus*). Aside from these, 5 insects are constant visitors to the burrows. The paper was briefly discussed by Messrs. Schwarz and Gill. Mr. Schwarz referred to the possible finding of a similar insect fauna in the burrows of the European Testudo and of the two other American species of Gopherus. Dr. Gill showed that the European species do not make burrows, and argued that in spite of the close resemblance of American forms to the Florida species we must not necessarily assume that they are burrowers. Mr. Schwarz said that the inhabitants at Penas, a station on the Mexican National Railway, near Laredo, informed him that there is a burrowing tortoise in the great sand plains near that place. This he thinks may be *G. berlandieri*.

Mr. O. F. Cook made some general remarks under the head 'Insect Collecting in Africa,' describing some of the rarities which he had found, giving in some detail his impression of the insect fauna of Liberia, and describing his experience with driver ants. These insects, he thinks, may be responsible for the almost total absence of snakes in Liberia, since when snakes are gorged with food they are motionless and defenseless and are easy prey for these active and voracious ants. Mr. Schwarz remarked that no trace of a more or less permanent nest of Eciton has ever been found, and the queen is not known. These ants make temporary nests and are in the main peripatetic. The fact that we do not know the queen, however, argues that a true nest will some day be found. He called attention to the fact that the Rev. P. Jerome Schmidt has found a species of Eciton in North Carolina.

Mr. Ashmead read a paper entitled 'Rhopalosomidae, a New Family of Fossorial Wasps.' Mr. Ashmead founds this new family upon *Rhopalosoma poeyi*, a Cuban species described by Cresson, specimens of which have recently turned up in different parts of the United States. Much discussion exists in the literature as to the proper systematic position of this insect, Westwood, Frederick Smith, Cresson, Haliday and Nylander having assigned it variously to the Ichneumonidae, Braconidae, Poneridae, Sphegidae and Vespidae. Mr. Ashmead's studies led him to place the species as the type of a new family of fossorial wasps, which will form a link between the Vespidae and Sapygidae. Discussed by Messrs. Marlatt, Schwarz, Gill and Uhler, mainly in regard to the fact that the insect seems to lack a fossorial facies.

L. O. HOWARD,
Secretary.

NEW YORK ACADEMY OF SCIENCES.

THE Academy met on October 14 with Professor R. S. Woodward, chairman of the Section of Astronomy and Physics, in the chair. 22 persons were present. The secretary presented verbally the minutes of the preceding meeting.

There being no business, the Section of Astronomy and Physics immediately organized, and listened to the first paper of the evening by Professor Harold Jacoby, entitled 'The Reduction of Astro Photographic Plates.' This paper was read by title, and was explained as being a discussion of the best formulæ for the reduction of the photographic plates taken by the International Committee for the Photographic Mapping of the heavens. It will be published as a bulletin of the Committee at Paris. Professor Jacoby then showed some lantern views of apparatus and astrophotographic plates taken at the observatory at the Cape of Good Hope.

The second paper was read by R. S. Woodward: 'Results of Experiments on Metallic Spheres Falling in Water.' Professor Woodward, after detailing various attempts to obtain data upon the law governing the motion of spheres in a liquid, reported the results of a preliminary series of experiments, made at Co-

lumbia College last June. The experiments were performed by dropping spheres of steel, silver, aluminum and platinum in a tube of water sixteen feet long and one foot in diameter. The spheres vary in diameter from one-half inch to two inches. The interesting results of these preliminary tests are that all the spheres acquired a constant velocity inside of the first meter. Newton's law that resistance to motion is proportional to the square of the velocity seemed to be verified. The times of falling were determined with a Hipp chronoscope. More elaborate experiments with the same apparatus will be made later. This paper was discussed by Professor Jacoby and others. W. Hallock reported upon some summer work, explaining the action of the vocal cords in voice production, and described the photographs taken of the cords while in action, illustrative of their operation.

The Academy then adjourned.

WM. HALLOCK,
Secretary of Section.

NEW BOOKS.

An Introduction to General Biology. WILLIAM T. SEDGWICK and EDMUND B. WILSON. 2d Edition. New York, Henry Holt & Co. 1895. Pp. xii+231.

Darwin and After Darwin. II. Post-Darwinian Questions Heredity and Utility. GEORGE JOHN ROMANES. Chicago, Open Court Publishing Co. 1895. Pp. x+344. \$1.50.

Weather and Disease. A Curve History of their Variations in Recent Years. ALEX. B. MACDOWALL. London, The Graphotone Co. 1895. Pp. 82.

Chemical Experiments, Prepared to Accompany Remsen's 'Introduction to the Study of Chemistry.' IRA REMSEN and WYATT W. RANDALL. New York, Henry Holt & Co. 1895. Pp. x+156.

An Atlas of the Fertilization and Karyokinesis of the Ovum. EDMUND B. WILSON and EDWARD LEAMING. New York, Columbia University Press, Macmillan & Co. 1895. 4to. Pp. vi+32. \$4.00.

SCIENCE

NEW SERIES.
VOL. II. No. 44.

FRIDAY, NOVEMBER 1, 1895.

SINGLE COPIES, 15 CTS.
ANNUAL SUBSCRIPTION, \$5.00.

GUSTAV E. STECHERT'S Recent Importation of Scientific Books.

ADICKES, DR. ERICH. Kant-Studien. 185 Seiten. gr. 8°. Mk. 4⁰⁰.

BENEDIKT, DR. MOR. Die Seelenkunde des Menschen als reine Erfahrungswissenschaft. 372 Seiten. 8°. Mk. 6⁰⁰.

BERNBACH, DR. W. Der elektrische Strom und seine wichtigsten Anwendungen in gemeinverständlicher Darstellung. Mit 90 Abbildungen. 108 Seiten. 8° Mk. 2⁰⁰.

BIEDERMANN, W. Elektrophysiologie. 1^o Abtheilung. Mit 136 Abbildungen. 440 Seiten. 8°. Mk. 9.

BOEGLE, DR. C. Die Entstehung organischer Formen. 18 Seiten. 8°. Mk. 1²⁰.

CAPITAINE, EMIL. Das Wesen des Erfindens. Eine Erklärung der schöpferischen Geistesthätigkeit an Beispielen planmässiger Aufstellung u. Lösung erfinderischer Aufgaben. 135 Seiten. 8°. Mk. 3⁵⁰.

DELAGE, YVES. La structure du protoplasma et les théories sur l'hérédité et les grands problèmes de la biologie générale. 878 pages. gr. 8° cloth. frs 24⁰⁰.

DÜHRING, DR. E. Wirklichkeitsphilosophie, Phantasmenfreie Naturergründung und gerecht freiheitliche Lebensordnung. 554 Seiten. 8°. Mk. 9⁰⁰.

FOREL, DR. AUGUST. Der Hypnotismus, seine psycho-psysiologische medicinische, strafrechtliche Bedeutung und seine Handhabung. 3^{te} verb. Aufl. mit Annotationen von Dr. O. Vogt. 223 Seiten. gr. 8°. Mk. 5.

FRICKS, DR. J. Physikalische Technik speciell-Anleitung zur Ausführung physikalischer Demonstrationen und zur Herstellung von physikalischen Demonstrations-Apparaten mit mögl. einfachen Mitteln. 6^{te} umgearb. und verm. Aufl. von Dr. Otto Lehmann. II. Band. Illustriert. 1054 Seiten. gr. 8°. Mk. 20⁰⁰.

GRIESBACH, PROF. DR. H. Physicalisch-Chemische Propädeutik unter besonderer Berücksichtigung der medicin. Wissenschaften u. mit histor. und biographischen Angaben. 1^{ste} Hälfte. Bogen 1-17 mit Figur 1-44. gr. 8°. Mk. 5⁰⁰.

HAACKE, DR. WILH. Die Schöpfung des Menschen und seiner Ideale. Ein Versuch zur Versöhnung zwischen Religion und Wissenschaft. Mit 62 Abbildungen im Text. 487 Seiten. gr. 8°. Mk. 12⁰⁰.

HAMPE, DR. JULIUS. Ueber Geisteskrankheiten in Folge Schwefelkohlenstoff-Vergiftung. 51 Seiten. 8°. Mk. 1⁵⁰.

HANSEN, DR. EMIL CHR. Untersuchungen aus der Praxis der Gährungsindustrie. Beiträge zur Lebensgeschichte der Mikroorganismen. 3^{te} verm. u. neubearb. Aufl. mit 19 Abbildgn. Heft I, 92 Seiten. gr. 8°. Mk. 3⁵⁰.

HALLIER, DR. ERNST. Die Pestkrankheiten (Infektionskrankheiten) der Kulturgewächse. Nach streng bakteriologischer Methode untersucht und in völliger Uebereinstimmung mit Robert Koch's Entdeckungen geschildert. Mit 7 Tafeln. 144 Seiten. Text. gr. 8°. Mk. 8⁰⁰.

HITZIG, DR. ED. Ueber den Quärlantenwahn-sinn, seine nosologische Stellung und seine forensische Bedeutung. Eine Abhandlung für Aerzte und Juristen. 146 Seiten. gr. 8°. Mk. 5⁰⁰.

JAHN, HANS. Grundriss der Electrochemie. 311 Seiten. gr. 8° Mk. 8⁴⁰.

KROMPECHER, EDMUND. Die mehrfache indirekte Kernteilung. Mit 9 lithogr. Tafeln. 275 Seiten. gr. 8°. Mk. 4⁰⁰.

LEHMANN, DR. O. Elektrizität und Licht. Einführung in die messende Elektrizitätslehre und Photometrie. Mit 220 Holzstichen u. 2 Tafeln. 390 Seiten. gr. 8°. Mk. 7⁰⁰.

NOLDE, BARON EDUARD. Reise nach Innerarabien, Kurdistan und Armenien 1892. Mit dem Bildniss des Reisenden und 1 Karte. 272 Seiten. 8°. Mk. 4⁵⁰.

Pharmakologie und Toxikologie mit Beiträgen von vielen Ärzten redigirt von A. Brestaniski. 967 Seiten. gr. 8°. Ladb. M. 25⁰⁰.

RICHTER, CARL. Die Galvanische Verzinkung des Eisens. Mit besonderer Berücksichtigung der neueren Methoden. Mit 18 Figuren im Text. 48 Seiten. 8°. Mk. 1⁵⁰.

SCHMIDT, DR. CARL. Das Naturereigniss der Sinfitt. Akademischer Vortrag. 63 Seiten. 8°. Mk. 1²⁰.

WELTER, DR. ADOLF. Die Tiefen Temperaturen, ihre künstl. Erzeugung, ihre Einwirkung auf Tiere, Pflanzen, Microorganismen, etc., sowie ihre Anwendung in der Industrie. 84 Seiten. gr. 8°. Mk. 2⁵⁰.

ZITTEL, KARL A. VON. Grundzüge der Paläontologie (Paläozoologie). Mit 2048 in den Text gedruckten Abbildungen. 971 Seiten. gr. 8°. $\frac{1}{2}$ mor. Mk. 25⁰⁰.

ZWAARDEMAKER, DR. H. Die Physiologie des Geruchs. Mit 28 Figuren im Text. 324 Seiten. gr. 8°. Mk. 9⁰⁰.

GUSTAV E. STECHERT,

810 Broadway, New York.

Macmillan & Co.'s New Books.

Loudon and McLennan.—A Laboratory Course in Experimental

Physics. By W. J. LOUDON, B. A., LL. D., Demonstrator in Physics in the University of Toronto, and J. C. MCLENNAN, B. A., Assistant Demonstrator in Physics in the University of Toronto. 8vo, cloth, \$1.90 *net*.

Ostwald.—The Scientific Foundations of Analytical Chemistry.

Treated in an Elementary Manner by WILHELM OSTWALD, Ph. D., Professor of Chemistry in the University of Leipzig. Translated with the Author's sanction by GEORGE MCGOWAN, Ph. D. 12mo, cloth, pp. 207, \$1.60 *net*.

Hutchinson.—Hand-Book of Grasses. Treating of their Structure, Classification, Geographical Distribution and Uses. Also Describing the British Species and Their Habitats.

By WILLIAM HUTCHINSON. With Illustrations. 12mo, cloth, 75 cents *net*.

Laurie.—Facts about Processes, Pigments and Vehicles. A Manual for Art Students.

By A. P. LAURIE, M. A., B. Sc., Lecturer on Chemistry, St. Mary's Hospital; late Fellow King's College, Cambridge. 12mo, cloth, edge cut, \$1.00 *net*.

Stewart.—An Elementary Treatise on Heat.

By BALFOUR STEWART, LL. D., F. R. S., late Professor of Natural Philosophy Victoria University, Owen's College, Manchester. Sixth edition, revised, with additions, by ROBERT E. BAYNES, M. A., student of Christ Church, Oxford, and Dr. Lee's Reader in Physics. New Edition. 12mo, cloth, \$2.25 *net*.

Murray.—An Introduction to the Study of Seaweeds.

By GEORGE MURRAY, F. R. S. E., F. L. S. With 8 Colored Plates and 88 other Illustrations. 12mo, cloth, \$1.75 *net*.

Tait.—Dynamics.

By P. G. TAIT, M. A., Sec. R. S. E., Honorary Fellow of St. Peter's College, Cambridge, Professor of Natural Philosophy in the University of Edinburgh. 12mo, cloth, \$2.50 *net*.

Wiedersheim.—The Structure of Man. An Index to His Past History.

By DR. R. WIEDERSHEIM. Translated by H. and M. BARNARD. The translation edited and annotated and a preface written by G. B. HOWES, F. L. S., Professor of Zoölogy, Royal College of Science, London. With 105 Figures in the Text. 8vo, cloth, \$2.60 *net*.

Wilson.—Atlas of the Fertilization and Karyokinesis of the Ovum.

By EDMUND B. WILSON, Ph. D., Professor of Invertebrate Zoölogy in Columbia College, with the cooperation of EDWARD LEAMING, M. D., F. R. P. S., Instructor in Photography at the College of Physicians and Surgeons, Columbia College. With Illustrations. 4to, cloth, \$4.00 *net*. (*Columbia University Press.*)

Keith.—Plea for a Simpler Life.

By GEORGE S. KEITH, M. D., F. R. C., P. E. 12mo, cloth, \$1.00.

MACMILLAN & CO., 66 Fifth Avenue, New York.

SCIENCE

EDITORIAL COMMITTEE: S. NEWCOMB, Mathematics; R. S. WOODWARD, Mechanics; E. C. PICKERING, Astronomy; T. C. MENDENHALL, Physics; R. H. THURSTON, Engineering; IRA REMSEN, Chemistry; J. LE CONTE, Geology; W. M. DAVIS, Physiography; O. C. MARSH, Paleontology; W. K. BROOKS, Invertebrate Zoology; C. HART MERRIAM, Vertebrate Zoology; S. H. SCUDDER, Entomology; N. L. BRITTON, Botany; HENRY F. OSBORN, General Biology; H. P. BOWDITCH, Physiology; J. S. BILLINGS, Hygiene; J. MCKEEN CATTELL, Psychology; DANIEL G. BRINTON, J. W. POWELL, Anthropology.

FRIDAY, NOVEMBER 1, 1895.

CONTENTS:

| | |
|--|-----|
| <i>The Third International Zoological Congress</i> | 565 |
| <i>Relations of the Weather Bureau to the Science and Industry of the Country</i> : E. L. MOORE..... | 576 |
| <i>Salix Wardi</i> Bebb: N. M. GLATFELTER..... | 582 |
| <i>Scientific Notes and News</i> :— | |
| <i>Edwards' Butterflies of North America; Davenport Academy of Natural Sciences; General</i> | 584 |
| <i>Educational and University News</i> :— | |
| <i>Annual Report of President Low of Columbia College; General</i> | 586 |
| <i>Correspondence</i> :— | |
| <i>The Problem of Solar Magnetism</i> : WM. HALLOCK. <i>Science or Poetry</i> : S. H. GAGE. <i>The Katydid's Orchestra</i> : JOHN B. SMITH, S. H. SCUDDER. <i>A Naturalist in Mexico</i> : WITMER STONE. <i>Shells as Implements</i> : HENRY W. HAYNES | 588 |
| <i>Scientific Literature</i> :— | |
| <i>Powell's Canyons of the Colorado</i> : W J MCGEE. <i>Harker's Petrology for Students</i> : JOSEPH P. IDDINGS | 593 |
| <i>Scientific Journals</i> :— | |
| <i>The American Journal of Science. The American Chemical Journal</i> : J. ELLIOTT GILPIN. <i>Psyche</i> | 599 |
| <i>New Books</i> | 600 |

MSS. intended for publication and books, etc., intended for review should be sent to the responsible editor, Prof. J. McKeen Cattell, Garrison on Hudson, N. Y.

Subscriptions and advertisements should be sent to SCIENCE, 41 N. Queen St., Lancaster, Pa., or 41 East 49th St., New York.

THE THIRD INTERNATIONAL ZOÖLOGICAL CONGRESS, LEYDEN, SEPT. 16-21, 1895.

THE International Zoölogical Congress was organized at Paris in 1889 and the second meeting was held at Moscow in

1892. Neither of these Congresses was conspicuously successful in attaining a truly international character. The third Congress, however, which met at Leyden, September 16-21 of the present year, was not only brilliantly successful from the scientific point of view, but was also thoroughly international in the best sense of the word, a result which the Committee of Organization took the greatest pains to secure. The whole number of members registered was 232, representing 22 nations and colonies. Of course, these numbers were not equally distributed, Holland having 64 and France 56 of the entire number. Of much more importance than mere numbers in giving this international character was the distinguished position of very many of the delegates, most of the countries being represented by their foremost zoölogists, and the quality of the papers presented was unusually high. The arrangements for the comfort and convenience of the members, for the meetings and excursions, were in all respects excellent, and the Committee of Organization, MM. Hubrecht, Jentink, Hoek and Horst, as well as the local committees, acquitted themselves of their difficult task to the admiration of all the visitors. Upon this subject there was entire unanimity of opinion, and none who had the privilege of attending this Congress are at all likely to forget the delightful and stimulating experience.

On Sunday evening, September 15th, an informal gathering of the members of the Congress was held in the summer building of the 'Amicitia' Club, which, like the other clubs of Leyden, was hospitably thrown open to the delegates. This occasion was principally remarkable for the graceful speech of welcome in three languages, made by Prof. A. A. W. Hubrecht, President of the Netherlands Zoological Society, under the auspices of which the Congress was held. This speech, which was warmly applauded, is given in full:

MESDAMES, MESSIEURS ET CHERS COLLÈGUES !

C'est avec une joie bien sincère que je prends la parole ce soir pour vous remercier au nom de la Société Néerlandaise de Zoologie de vous être rendus à la bonne ville de Leyde afin d'y constituer un troisième Congrès International de Zoologie, qui a été précédé par les seuls Congrès de Moscou et de Paris.

Nous avons beaucoup apprécié la décision qu'a prise le Congrès de Moscou, il y a trois ans, de conférer l'honneur de la troisième session à la Hollande.

Aujourd'hui nous nous félicitons de nous voir entourés d'une réunion si nombreuse de savants des divers pays d'Europe, d'Asie et d'Amérique, voire même d'Afrique, qui ont bien voulu répondre à notre appel. Nous tous, nous aurons l'occasion de constater qu'une semaine, comme celle qui nous attend, va porter des fruits utiles à la science en même temps qu'elle va tisser de nouveaux liens d'amitié entre ses adeptes.

Ce soir nous ne sommes pas encore le Congrès International, ce soir nous ne sommes que des molécules libres qui ne demandent qu'à se combiner au plus vite en un produit d'un ordre plus élevé et d'une utilité incontestable, sous la direction du chimiste si compétent, notre collègue le Dr. Jentink.

Profitons donc de la liberté dont nous jouissons encore ce soir pour ne pas le con-

sacrer à des discussions scientifiques, mais uniquement à nouer et à renouer des liens personnels d'amitié, ce qui sans aucun doute constitue un des avantages les plus précieux de ces réunions internationales.

Es giebt aber *einen* Punkt über welchen man sich in diesen internationalen Zusammenkünften hinweg zu setzen wissen muss, n. l. eine all zu grosse Vorliebe und eine zu sorgsame Pflege seiner Muttersprache. Ein jeder von uns wird es sich gefallen lassen müssen, dass er seine Fachgenossen aus aller Herren Ländern, sowohl aus Höflichkeits- wie aus Bequemlichkeitsgründen in ihrer anstatt in seiner eigenen Sprache anzureden haben wird und wir werden uns freuen, wenn ein uns interessirender Vortrag eines ausländischen Collegen uns zu gleicher Zeit die Gelegenheit verschafft unsere Sprachkenntnisse zu erweitern. Die Niederländische Zoologische Gesellschaft, welche sich für ihre Einladungen zum Congress von drei modernen Sprachen bedient hat, hofft, dass auch die Mitglieder sich innerhalb des Rahmens dieser drei Sprachen einzuzwingen wissen werden. Soviel ich weiss werden wir Holländer den Herren nicht mit einer einzigen auf Holländisch vorzutragenden Mittheilung das Leben sauer machen.

Dem Thurmbau unserer Wissenschaft wird es zu Gute kommen, wenn wir die Sprachverwirrung—die traditionell am Ende einzutreten verspräche—gleich im Anfang in beherrschbarre Bahnen zu lenken wissen.

And so, to complete the trilogy of languages which I have recommended to your consideration, I ought to set a good example and to close these few words of welcome to the members of the Congress that is to be, in the language that was spoken by Newton, by Harvey, by Darwin and by Huxley.

This language is undeniably spreading all over the globe with greater rapidity than any other, and has got a very firm hold on

the five continents. Without speculating about its future, we may admire the simplicity of its grammar and the terseness and conciseness of style by which so many of its scientific worthies have distinguished themselves. We are very pleased to see so many of its representatives in our midst and I feel sure that they will largely contribute to the success, both of this and of many future International Zoological Congresses.

And now I propose to give you all the most hearty *welcome to Holland!*

Auf Ihr wohl, meine Herren.

Je vous souhaite la bienvenue à vous tous et je bois au succès du prochain troisième Congrès International de Zoologie.

MONDAY, SEPTEMBER 16TH.

The Congress was formally opened by an address from the Minister of the Interior, M. van Houten, honorary President of the Congress, which was responded to by the President, Dr. Jentink, Sir William Flower on behalf of Great Britain, Professor A. Milne Edwards for France, Baron E. de Sélvs de Longchamps for Belgium, and Dr. C. W. Stiles for the United States. Professor Weismann was then called upon and delivered a long and formal address, the publication of which will be awaited with great interest. He defended the principle of natural selection and developed certain new ideas complementary to this principle. Darwin and Wallace have proved the existence of selection between individuals, and Roux has shown that there is a struggle between the constituent parts of each organism. This struggle is of the highest importance for the life of the organism and, *à fortiori*, for the existence of the species. It is necessary, in the third place, to call attention to what the speaker has named *germinal selection*. The smallest vital units, the biophors and determinants, of which, according to his ideas, all living organisms

are formed, are in more or less favorable reciprocal conditions. It is just this which gives us the key to the fact that useful variations are always presented when selection requires them. The direction in which variations develop is determined by their utility. Here is an automatic mechanism which determines that useful variations shall be protected from their incipient stages, and under the sheltering mantle of individual selection these variations attain complete development. This dominant idea was supported by numerous examples taken from organisms which are advancing, as well as from those which are retrograding. The principle of Panmixia is thus logically completed and it becomes possible to explain why harmonious variations in different parts of the organisms are produced simultaneously.

Professor R. Blanchard reported on behalf of the committee that the prize instituted by the Emperor of Russia had been awarded to Dr. R. T. Scharff, of Dublin.

The following gentlemen were appointed permanent secretaries of Sections: Section I., Professor J. van Rees, Amsterdam; Section II., Dr. C. L. Reuvens, Leyden; Section III., Professor J. F. van Bemmelen, the Hague; Section IV., Professor G. C. J. Vosmaer, Utrecht; Section V., M. H. P. Nierstrasz, Utrecht; Section VI., Professor M. C. Dekhuysen, Leyden. The presidents of Sections were changed at each meeting. At 2.30 P. M. the Sections held their first meetings and were classified as follows: I. General Zoology. Geographical Distribution (including extinct faunas). Theory of Evolution. II. Classification and Distribution of recent and fossil Vertebrates. III. Comparative Anatomy of recent and extinct Vertebrates. Embryology. IV. Classification and Distribution of recent and extinct Invertebrates. V. Entomology. VI. Comparative Anatomy and Embryology of Invertebrates. This arrangement is re-

markable for the full recognition given to paleontology as a branch of zoölogy.

Prof. Sedgwick (Cambridge) read a paper on Cellular Theories, in which he pointed out the morphological inconsistencies and absurdities to which the prevalent theories lead.

Prof. Hensen (Kiel) made a report upon his Plankton studies, of which he considered the most interesting result to be the fact that the method of measuring percentages of various animals collected at different depths by fine, self-closing nets proves to be exact and may be employed as a basis for further investigations.

Prince Roland Bonaparte spoke of the researches in marine zoölogy made on the steamer 'Roland,' which he had placed at the disposal of M. de Lacaze Duthier.

Prof. Lütken (Copenhagen) spoke of the expedition for exploration of the great depths of the subarctic seas.

Prof. Scott (Princeton) made some remarks upon the relation of individual variations to the origin of species.

Prof. de Zograf (Moscow) gave a paper upon the origin of the lacustrine fauna of European Russia. The Russian lakes may be divided into four groups, the first derived from a bay of the White Sea and from a glacier; the second and third are the remains of glaciers. These three regions have the same limits as the three glaciers of the latter glacial periods of Geikie. The fourth group is derived from the Black and Caspian and other ancient seas which once covered southern Russia.

M. Vaillant (Paris) spoke of his researches on the structure of the osseous spine in the carp

Prof. Emery (Bologna) made a communication upon the polymorphism of ants and upon alimentary castration, defending the principle that the sterility of neuters and their different forms are chiefly due to the way in which the larvæ are fed.

The paper of M. Wasmann (Exaeten) dealt principally with the determination and classification of the ants and termites, giving the criteria of division with especial reference to those morphological characters which are of an adaptive nature.

At 4:30 P. M. the members of the Congress were received, by invitation of the Municipal Council of Leyden, in the Town Hall, where the Burgomaster welcomed them in a graceful speech, to which the President, Dr. Jentink, responded. The day was very agreeably ended by a concert at Katwijk given to the Congress.

TUESDAY, SEPTEMBER 17TH.

Prof. O. C. Marsh (New Haven) gave a paper upon the affinities and classification of the Dinosaurian Reptiles, illustrated by diagrams of *Actosaurus*, *Hallopus*, *Triceratops*, *Stegosaurus* and others, and of footprints, one of which shows a difference in the number of digits of the fore and hind feet. A new classification of the Dinosauria was proposed.

M. Büttikofer (Leyden) gave an account of the Dutch expedition to the interior of Borneo.

Prof. Lütken spoke of the investigations made in Denmark upon the fossil mammals of the Brazilian caverns.

Dr. C. W. Stiles (Washington) read a paper on the 'Revision of the Leporine Cestodes,' based upon the original types of European species and upon extensive American material. None of the European species have been found in North America.

M. S. Goto (Tokio) gave a short report on some ectoparasitic Trematodes from the Atlantic coasts of the United States and communicated also a case of synonymy of an European species. The species treated of are as follows: (1) *Tristomum leve*, Verrill. Examination of an original specimen shows that this is identical with the species described under the name

of *Tristomum ovale* by the speaker, so that *Tristomum ovale*, Goto, is a synonym of *Trist. læve*, Verrill. (2) *Phyllonella hippoglossi* (P. J. v. Beneden). This is the species called *Epibdella hippoglossi* by v. Beneden. The distinction between the two genera is that *Epibdella* has a pair of well-developed anterior suckers, while *Phyllonella* has none. The vagina is present and opens into the yolk reservoir, as in other species of *Tristomidae*. The 'vésicules séminales' of v. Beneden is the prostate gland and the internal cavity of the penis, while the vesicula seminalis of Cunningham is the vagina. (3) *Polystomum Hassalli*, n. sp. This species was found by Dr. Hassall, of Washington, in the bladder of *Kinosternon pennsylvanicum*. Body 1.5 mm. long, egg-shaped, genital hooks 16(3) and of the same size. Ovary sometimes on the right, sometimes on the left side. Intestine bifurcated, not branched. The *Polyst. oblongum* of Leidy is not *Polyst. oblongum*, Wright. (4) *Hexacotyle thunninae* (Par. et Per.). This is the *Octocotyle thunninae* of Parona and Perugia. The form of the body, the structure of the suckers as well as that of the vagina, shows that the species ought to be brought under the genus *Hexacotyle*.

In conclusion the speaker referred to the so-called 'grosse Zellen.' Under this name structures of various natures have been included, viz., (1) ganglion cells, (2) connective tissue cells, (3) gland cells.

Prof. S. J. Hickson (Manchester) in speaking of the classification of the *Alecyonaria* referred to the difficulty there is in finding sufficiently distinct characters to separate the *Alecyonaria* *Gorgonacea*. He considers that the *Corrallidae* and *Briarceidae* should be included among the *Alecyonacea* and not among the *Gorgonacea*.

The author then referred to some difficulties in the determination of species from museum specimens of *Alecyonarians*.

Prof. R. Blanchard (Paris) made a communication upon the leeches of the Dutch East Indies and of the Indo-Malayan region.

M. Dollfus (Paris) read a paper on the distribution of the isopod family, *Oniscidae*, in Europe. This group is particularly favorable for such studies, for most of its species exactly follow climatic zones. Most of them belong to the Mediterranean region, *stricto sensu*; some present curious phenomena of penetration toward the north or south, and a single one is ubiquitous. Three species of *Armadillo*, one of *Eluma* and twenty-five of *Armadillidium* were considered.

Baron E. de Sélvs de Longchamps (Liège) presented a paper entitled 'Progress in knowledge of the Odonata.'

M. Piepers (the Hague) spoke of supposed cases of mimicry among the insects, and expressed doubts concerning several so-called facts to which a place has been accorded in science before they have been sufficiently studied.

Prof. Perrier (Paris) gave an account of the marine laboratory on the island of Tahiti, of which he is the founder and director. It supplies facilities for researches in pure science, also for those bearing on fisheries and pisciculture. It is furnished with all necessary appliances and covers a space of 4 hectares.

M. Bolsius (Oudenbosch) read a paper upon the nephridea of the leeches, which, he contended, are separate from the ciliated organs. Prof. Kowalevsky (St. Petersburg) then gave a paper on contributions to the anatomy of the *Clepsines*.

Prof. Julin (Liège) communicated the work of his pupil, R. Legros, on the structure and development of the sexual organs in *Amphioxus* and the *Ascidians*. In both groups there is close homology in the formation of the sexual products. The cavity of the ovary and testis is homologous

with that in *Amphioxus* (coelom). The simple epithelium covering the germinal epithelium, together with that covering the sexual ducts, is, as a whole, homologous with the somatopleuric and splanchnopleuric epithelium covering the sexual glands of *Amphioxus*.

In the afternoon no Sectional meetings were held, the time being given to a lecture by Prof. Scott (Princeton) on the Tertiary Lakes of North America and their Mammals, which was illustrated by lantern slides. The lecturer pointed out that paleontology must be founded upon exact stratigraphy, and then gave an account of the American Tertiaries, indicating their European equivalents. Especially dwelt upon were the remarkable continuity of the American Tertiary horizons, their vast geographical extent, and the abundance and excellent preservation of their mammals. Many phylogenetic series may be worked out with great completeness, and from these may be deduced important laws as to the mode of development among mammals and their migration from one region to another.

In the evening a very large and brilliant audience, including the Queen and Queen Regent of Holland, assembled in the Concert Hall for the lecture of Dr. R. Bowdler Sharpe, of the British Museum, upon 'Some Curiosities of Bird Life.' The lecture was illustrated by a remarkable series of lantern slides painted by the Dutch artist Keulemans.

After Dr. Sharpe's lecture a reception to the Congress was given by the members of the students' club 'Minerva,' in their spacious and luxurious club house.

WEDNESDAY, SEPTEMBER 18TH.

The second plenary session of the Congress was opened at 10 A. M. Professor A. Milne Edwards then delivered a lecture upon the resemblances of the fauna of the Mascarene islands and that of certain is-

lands in the south Pacific. The lecturer pointed out the importance of the study of sedentary animals for the solving of distributional problems. The former existence of flightless birds in Madagascar and the neighboring islands has long been known. In 1889 M. Sauzier exhumed a large quantity of bones, which enabled Newton, Sclater and others to confirm the accounts of the traveller Leguat. The researches of Forbes, Newton and Hutton were then considered. These show that the Mascarene islands were formerly part of a great land area, which has been submerged beneath the ocean.

M. E. L. Bouvier (Paris) presented a report upon Dr. Herbert H. Field's plan of bibliographical reform and for the establishment of a central bibliographical bureau for zoology. The recommendations of the report are: (1) An International Bureau shall, as soon as possible, give effect to Dr. Field's plan for the reform of zoological bibliography. (2) National committees, established in each country, under the auspices of the zoological societies, will cooperate to simplify the work of the Bureau and to facilitate the reform. (3) In order to supply the Bureau with the necessary resources, the national committees will obtain subscriptions from individuals and learned societies. (4) An International Commission shall be appointed by the Congress to audit the accounts, assure the permanence and supervise the operations of the Bureau. This commission shall be composed of seven members, each of a different nationality; it shall report to the International Zoological Congress, and shall be renewable, in alphabetical order, at each meeting of the Congress.

These recommendations were unanimously adopted and the following commission was then appointed: For England, Prof. S. J. Hickson; for France, Prof. R. Blanchard; for Germany, Prof. J. W.

Spengel; for Holland, Dr. P. P. C. Hoek; for Russia, Prof. W. Schimkewitsch; for Switzerland, Prof. A. Lang; for the United States, Prof. W. B. Scott.

Prof. F. E. Schulze proposed the appointment of a commission of five members to codify the rules of nomenclature of living beings now used or recommended in various countries; the code to be published with the same text in three languages.

The proposition was unanimously adopted and the commission appointed as follows: Prof. R. Blanchard (Paris), Prof. Victor Carus (Leipsic), Dr. F. A. Jentink (Leyden), Dr. P. L. Selater (London), Dr. C. W. Stiles (Washington).

The following resolutions introduced by Dr. Stiles were unanimously carried:

Whereas, The Third International Zoölogical Congress considers Article 16, 3-1(1) of the Universal Postal Convention of Vienna, forbidding the transmission through the mails of "*animals and insects, living or dead, excepting the cases provided for [i. e., live bees] in the Regulations of detail,*" as a hindrance to the advancement of science, and

Whereas, Switzerland is at present the seat of the *International Bureau of the Universal Postal Union*, be it therefore by this Third International Congress held at Leyden, September 16-21, 1895,

Resolved, That this Third International Congress respectfully petition the Swiss Federal Government through its delegate, Prof. Studer, to introduce, at the next International Postal Congress, the following amendment to Article XIX. (Samples), 4, of the '*Regulations of Detail and Order,*' *i. e.*,

5th. Natural History Specimens—such as dried or preserved animals and plants, geological specimens, etc.—not sent for commercial purposes, provided the packages conform to the general conditions prescribed for '*Samples of Merchandise,*' and be it further

Resolved, That this Third International Congress call upon all of its delegates and members to bring this amendment to the attention of their respective governments, and to urge the several governments to instruct their delegates to the next International Postal Congress (Washington, D. C., 1897) to support the same; and be it further

Resolved, That the Secretary of this Third International Congress send a copy of these resolutions to every government represented in the Universal Postal Union, but not represented at the Third International Zoölogical Congress.

Wednesday afternoon was occupied by an excursion to the Hook of Holland.

THURSDAY, SEPTEMBER 19TH.

Sectional meetings at 10 A. M. Prof. Apáthy (Klausenburg) presented a paper upon a controlling element and its position with reference to the cells in invertebrates and vertebrates. The speaker distinguished between ganglion cells and nerve cells; the latter (as the muscle cells do for the contractile substance) produce the controlling substance which grows out, reaches and penetrates ganglion cells, sensory cells and muscle cells. This is done by means of the intercellular bridges, derived from the embryo, which always connect together the cells of the body. The old conception of Max Schultze has thus again been brought forward in opposition to the views of Bütschli, Leydig and others. By the gold chloride method, confirmed by methyl blue and other stains, Prof. Apáthy has been able to distinguish both kinds of cells and the finer details of the controlling primitive fibrils, especially within the ganglion cells, and also to establish the connection between the controlling motor and sensory primitive fibrils. An extremely interesting demonstration of these facts was given at the close of the session.

M. C. Janet (Beauvais) read a paper

showing that the problem of species and their variations may be compared to the examination of the positions of equilibrium of a point placed on a resisting surface and submitted to the action of a force which is a function of the coördinates of the point. The discussion of this problem of mechanics, translated into zöological language, leads to the following conclusions: That in a given fauna in a given environment there is but a limited number of possible species, and that the passage of the initial forms to the definitive forms will be made very rapidly. This explains the small probability of finding remains of the transitional forms. The same applies to the transition of one fauna to another under the action of a changed environment.

Prof. Eimer (Tübingen) spoke on definitely directed development (orthogenesis) and the impotence of Darwin's selection in the formation of species; also upon the development of species and affinities of the swallow-tailed butterflies. The speaker's works, which in part have been published for years, especially those on the markings of animals, show that definitely directed development is an unquestionable fact and his continued investigations everywhere confirm this. Variation always takes place in a few quite distinct directions, progressively, or sometimes (Foraminifera) retrogressively, *never* 'oscillatingly.' Utility plays no part, either in the minimal beginnings or in the further development. Transformation is to be referred to the influence of the environment upon a given constitution. Selection can create nothing new, but what is developed *may* become useful and be selected. The separation into species of the chain of organisms thus formed occurs chiefly through arrest at definite stages of development (Genepistasis) as well as by saltatory development (Halmatogenesis) and by hindrance of fertilization (Kyesomechania). Even the

origin of apparently mimicking forms is to be explained by definite directions of development (independent similarity of development, Homæogenesis). Only thus, not by selection, is the origin of mimicry made intelligible. The speaker employed, as evidence for his views, figures of the *Papilionide*, from which, as he said, the laws of development and of the formation of species⁸ may be read as from the letters of a book. The fact of the definitely directed development of non-useful characters completely refutes the lately propounded 'germinal selection.' Speculation may have its place in natural science, but it must not ignore *facts* previously established.

Dr. R. Bowdler Sharpe presented a paper on the geographical distribution of the birds of prey, and M. F. Mocquard (Paris) one upon some new reptiles and amphibians from the upper Congo.

Dr. T. Schmitt made a communication on the principles followed in preparing the new edition of the Scandinavian Fishes.

In the paper of M. Forrest, presented by the Baron d'Hamonville, upon the ostrich, egrets and birds of paradise, the principal points were: (1) Reintroduction of the ostrich into North Africa. (2) To have measures for the protection of the egrets universally adopted. (3) To obtain protection for the birds of paradise.

Prof. W. Leche (Stockholm) gave an outline of his investigations upon the development of the dental system in mammals, emphasizing the general considerations which are to be regarded in this question. He dwelt upon the fact that the serial appearance of the teeth had been only gradually acquired and also that there are no impassable barriers between the different dentitions. He pointed out the occurrence of at least four dentitions in the mammals and made some statements concerning the genesis of these.

Prof. Semon (Jena) spoke on the fœ-

tal membranes and appendages of vertebrates. He referred the formation of the amnion to the need of protection for the germ when the eggs are laid on land. Mechanically regarded, the process may be considered as a sinking, first of the front end, and then of the hinder end, of the embryo into the yolk sac. The development of the allantois as a respiratory organ keeps pace with the sinking of the embryo. In the structure and development of their fetal membranes and appendages the monotremes stand between the Sauropsida and the higher mammals.

Prof. Hubrecht (Utrecht) gave a demonstration of lemurine placentas. He finds the placentation of *Tarsius* to be entirely different from that of *Nycticebus* and other lemurs. While *Nycticebus* has a diffuse placenta, in *Tarsius* the chorion is quite thin and transparent, except at one spot, which forms a discoid placenta, so to speak. This develops at first as a massive cone, which grows into an especially modified part of the uterine wall. The allantois grows into this cone and surrounds the maternal blood vessels.

Prof. Zograf (Moscow) made a communication upon the teeth of the chondrosteaganoids. The sturgeons possess teeth in the young stages which are preserved longer in the eastern species than in the western. A series may be made from the sterlet (*A. ruthenus*), which loses its teeth toward the end of the first year, to *Psephurus gladius*, which retains them throughout life. The American *Polyodon folium* also retains its teeth permanently, but nothing is known in this respect of the other sturgeons of that continent. It is to be hoped that American investigators will soon clear up this point.

Mme. Céline Renooz (Paris), in a paper on the embryonic development of vertebrates, explained her views as to the derivation of aerial animals from plants and the

vegetable traces which occur in the first stages of embryonic development.

Prof. van Bemmelen (the Hague) presented a paper on the phylogeny of the Testudinate reptiles. The perforated cranial roof of the fresh-water turtles, as well as that of the lizards and snakes, must be derived from the uninterrupted roof of the marine forms. In the series of turtles the quadrate has developed into a tympanic ring, probably homologous with that of the mammals. The plastron contains elements of different phylogenetic antiquity; the anterior three are the homologues of the episternum and clavicles.

Prof. Kowalevsky spoke of the lymphatic glands of *Scorpio europæus* and certain allied forms. In some of these may be distinguished one class of glands which deals with solid substances and the lymphoid glands which prefer dissolved matters.

Prof. Schimkewitsch made a communication upon the first stages of development in the parasitic copepods. He has observed the segmentation, the formation of the germ layers, the very precocious development of the germinal cells, and the formation of the nervous system in the same way as in *Gammarus* as given by Bergh.

Prof. Gilson (Louvain) described the special muscular organs which he has discovered in the dissepiments of *Owenia*. It seems certain that these organs serve to regulate the pressure of the perivisceral fluid in the different segments and occasionally to isolate certain segments. Epithelial tubes situated in the fifth and sixth dissepiments and opening externally lead to the septal canal, and seem destined to introduce water into the perivisceral cavity for the needs of the hydraulic mechanism which constitutes the body of this tubicolar annelid.

M. Dautzenberg (Paris) gave an account of new molluscs dredged from near the Azores and the coast of Senegal—another

instance of the wide distribution of deep sea forms.

Prof. Perrier (Paris) spoke on the classification of worms. The Nematodes, with *Echinoderes*, *Gordius* and *Acanthæcephalus*, are separated from the worms and, under the name Nematelminthes, united with the Arthropods. The Plathelminthes and Annelids constitute the worms proper. The Rotifers, Bryozoans and Brachiopods form a group (Lophostomata) transitional between the Plathelminthes and Annelids.

Prof. Julin (Liège) read an elaborate paper on 'the epicardium, pericardium, heart and stolon in the larvæ of *Distaplia magnilarva*,' which is not reported in the Bulletin of the Congress.

Prof. Salensky (Odessa) gave an account of the development of the heart in the frog, from which it follows that the vertebrate heart is totally different from that of the Tunicates and that the endocardium is of mesodermal origin.

Prof. Eimer read a paper upon the formation of the tailed species of *Papilio*, in which he further developed his ideas on Orthogenesis referred to in the former paper.

The day was charmingly concluded by a 'dinner intime' in the Kurhaus at Scheveningen.

Friday, September 20th, was devoted to excursions to Helder, Marken and Grave-land.

SATURDAY, SEPTEMBER 21ST.

The paper which excited perhaps the greatest interest of all those presented to this Congress was that by Dr. E. Dubois on '*Pithecanthropus erectus*, a transitional, man-like form.' Dr. Dubois described the locality in Java where the remains were found, and mentioned as occurring near them a tooth of *Hyæna*, bones of *Cervus*, etc. No complete skeleton was found. The speaker then described the cranium and femur, of which he had maintained that they be-

longed to a man-like creature. He had compared the thigh bone with 150 different femora of Malays, Negroes, Europeans and other races, but could establish no similarity. Virchow's view of the greater resemblance of this femur to that of the apes (especially *Hylobates*) is correct. It is remarkable that the zoologists maintain the skull to be human, while the human anatomists refer it to the apes. The speaker discussed the cranial capacity of man and the anthropoid apes, with especial reference to the Neanderthal skull. In his published work Dr. Dubois had not referred to a second tooth found later among the excavated material. The speaker concluded that *Pithecanthropus erectus* should be placed between man and the anthropoid apes, that it represents a peculiar type and renders necessary the formation of a new genus.

Prof. R. Virchow (Berlin) opened the discussion with the statement that he agreed better with Dr. Dubois than would be supposed from newspaper accounts. He displayed some human femora, with exostoses like the Javan specimen. Virchow inclined to the view that the femur was human, but could not deny that the whole appearance of the bone was not man-like; it is most like that of *Hylobates*, but gigantic compared with the recent gibbons. He expressed himself positively against the opinion that the skull is human and explained the importance of the orbital region in such questions. Dubois' discovery is a very important one.

In reply Dr. Dubois pointed out the likeness of this skull to that of Neanderthal.

Prof. Marsh called attention to the great age of the bones. He had often observed similar exostoses on fossil femora. It is extremely desirable to establish the antiquity of the specimens.

Prof. Rosenberg (Utrecht) pointed out certain characteristics of femora; the long axis and its curvature, the linea obliqua,

crista trochanterica, linea aspera, angulus medialis, &c. Of the human femora examined, one showed all four peculiarities of the Javan specimen, so that he doubted whether the latter differed from a human femur. He also doubted the reference of the skull and explained why he did not believe that *Pithecanthropus* had an erect gait. He would like to have these bones compared with those of the New World monkeys.

Prof. Martin (Leyden) stated that the age of these bones could only be late Pliocene or early Pleistocene.

Sir William Flower laid much stress upon the correspondence between the skull of *Pithecanthropus* and that of *Hyllobates*.

Dr. Bashford Dean (New York) spoke 'On the Embryology of the North American Ganoids, *Accipenser*, *Lepidosteus* and *Amia*,' and exhibited a number of specimens illustrating their embryonic and larval development. A comparative study of these forms emphasizes the results of the palæontologist as to the phylogeny of the Teleosts, *i. e.*, their descent from a series of transitional Mesozoic Ganoids, as Leptolepids, Caturids; it interprets also the difficulties of the embryology of the Teleost, *e. g.*, the origin of the periblast, the mode of gastrulation, of blastulation, the significance of Kupffer's vesicle, of the solid neural axis, and of the specialized origin of the mesoderm. In a series of diagrams of saggital sections of early and late gastrulæ there was shown on the screen a more detailed comparison; thus in *Lepidosteus* shark like features were apparent, the conditions of the development of the germ layers of ventral and dorsal lip were closely similar, and by the time of the blastopores closure the appearance of the embryo was hardly to be noted. In *Amia*, on the other hand, the precocious character of the development of the embryo was extremely notable, forming clearly marked transitional conditions to the Teleosts.

At 2 P. M. was held the third and last session of the full Congress, when Mr. John Murray (Edinburgh) delivered a lecture upon 'Deep Sea Explorations.' He showed the respects in which our knowledge of the great ocean depths and of their animal life has so greatly increased in the last 40 years, and that the biological sciences have reaped the chief benefit of such increase. The greatest measured depth in the sea is 8500 metres, the mean depth 4500 metres. About 5 per cent of the deep part is 5500 m. or more. Mr. Murray then gave an account of the investigation of the bottom deposits undertaken by himself and M. Rénaud, of Brussels, which had led to such important results. The question of temperature was then taken up. This varies at the surface from 28° at the equator to 0° at the poles; at the bottom the water has a temperature almost everywhere equal and constant, averaging 3°. It is especially remarkable that in the tropics the number of deep sea species is much greater than in temperate regions, but in the latter the number of individuals of each species is far larger. The speaker then considered some of the characters of deep-sea animals. We have not succeeded in finding animals which can be considered representatives of extinct faunas. The forms are distinct; they are often of considerable size, they carry phosphorescent organs and usually have no striking colors; but on the whole they resemble animals from less profound depths. A very curious point is the resemblance between the deep sea forms of high latitudes, north and south. This was explained by assuming that the bottom had formerly the same fauna everywhere. The temperature was then uniform and a rich flora flourished at the poles, as at the equator. At that time the sun did not give out much more heat than at present, but its radiating surface was far larger, and therefore the distribution of solar heat upon the

earth was quite different from that which obtains at present.

Baron d'Hamonville next made an eloquent plea for protection to the birds of paradise and appealed to the ladies for support in this movement.

Dr. Herbert H. Field (Brooklyn) transmitted to the Congress a proposition of Prof. E. L. Mark, Cambridge, U. S. A., to "consider the desirability and feasibility of constructing a code of abbreviations in animal morphology based upon Latin names and to be recommended for general use by zoölogists and anatomists throughout the world."

The Congress voted unanimously that Sir William Flower should be the president of the fourth Congress, and that this should be held in England, the president-elect to agree with his English colleagues upon the place of meeting.

After speeches from MM. Milne-Edwards, Studer, Sélys-Longchamps and Flower, expressing the high appreciation felt by all the members for the admirably successful labors of the Dutch committees and the remarkable character of the work laid before the Congress, the president declared the sessions of the Third International Zoölogical Congress to be closed.

— — —

*RELATIONS OF THE WEATHER BUREAU TO
THE SCIENCE AND INDUSTRY OF
THE COUNTRY.*

MR. PRESIDENT and members of the American Association for the Advancement of Science:

It is a matter of much pleasure to me that I am allowed the privilege of speaking at a joint session of this Association—representing as it does within the confines of its admirable organization the scientific thought of our country. This is the Mecca towards which annually journey all those who wish, each to contribute his mite to the sum of human knowledge; each inspired with an ambition to add even one flickering

ray to the great luminous orb which to-day is shedding the benign light of wisdom even unto the uttermost recesses of the earth; subduing the barbarous instincts of man and warming and invigorating into life the better impulses of his nature. Thus is civilization advanced, and thus is humanity elevated to higher and higher planes of existence.

I hope to be a worker in the ranks of this great army, and as the science of meteorology can hardly be said to have passed beyond the embryonic state, I feel that the realms of investigation are boundless, and that the opportunities are correspondingly great.

As the Chief of the greatest meteorological system in the world, and with the power to control, under the direction of the Honorable Secretary of Agriculture, not only its executive functions, but the lines of future scientific investigation, I fully realize the great responsibility that rests upon me, and that, at the bar of public and scientific opinion, I shall, in the years to come, justly be held to a strict accountability for my stewardship.

Before considering the lines of investigation which can consistently be prosecuted by the Weather Bureau, it will be well to note the law which prescribes the duties of the chief.

By an Act Congress approved October 1, 1890, Sec. 3, Statutes at large, Fifty-first Congress, p. 653, it is provided:

"That the Chief of the Weather Bureau, under the direction of the Secretary of Agriculture, on and after July 1, 1891, shall have charge of the forecasting of weather, the issue of storm warnings, the display of weather and flood signals for the benefit of agriculture, commerce and navigation, the gauging and reporting of rivers, the maintenance and operation of sea-coast telegraph lines and the collection and transmission of marine intelligence for the benefit of commerce and navigation, the reporting of temperature and rainfall conditions

for the cotton interests, the display of frost and cold wave signals, the distribution of meteorological information in the interests of agriculture and commerce and the taking of such meteorological observations as may be necessary to establish and record the climatic conditions of the United States, or as are essential for the proper execution of the foregoing duties."

It will be seen that the main object for the existence and continuation of this Bureau is to give warning of the approach of storms, and therefore that the proper line of investigation should be for the purpose of determining the true philosophy of storms. The goal to be striven for is the improvement of weather forecasts, and surely one of the prerequisites to determine coming events is a thorough knowledge of existing conditions.

To those who have read every important treatise on meteorology, and who have studied every text-book on the subject, it is painfully patent that we are extremely ignorant of the mechanism of storms; of the operations of those vast and subtle forces in free air which give inception to the storm and which supply the energy necessary to accelerate cyclonic action when formed, or to disperse the same when once fully in operation. We know that great atmospheric swirls in the shape of high and low pressure areas alternately drift across the country at intervals of two or three days; that the atmosphere flows spirally into the cyclonic or low-pressure system and outward from the anti-cyclonic or high-pressure system, that the in-drawn east and south winds on the front of the storm are warm, and that the inwardly-flowing north and west winds are cold.

The theories of Redfield, Espy, Loomis, Ferrel and others, teach that our great storms are composed of immense masses of air gyrating about a vertical or nearly vertical axis, drifting eastward and at the same time drawing in warm easterly currents at

the front and cold westerly currents at the rear; that the commingling of these two as they rise to greater and greater elevations, near the regions of the cyclonic center, throws down volumes of rain or snow; that as precipitation occurs with the ascending currents, the heat of condensation energizes the cyclonic circulation; that the air at the center of the storm is relatively warm, is rarefied by centrifugal force and by reason of less density, rises to a great elevation, and in the upper regions of the atmosphere flows away laterally to assist in building up high-pressure areas on either side.

The high and low-pressure areas are supposed to be carried eastward by the general easterly drift of the atmosphere in the middle latitudes, somewhat as eddies are carried along by water in a running stream.

But, unfortunately for the complete accuracy of these theories, the forecaster often finds heavy down-pours of rain without any cyclonic circulation, and no convectional system in operation; again over immense areas of country, especially in the Rocky Mountain region, for many months in the year condensation occurs not at all in the warmer easterly currents flowing into the storm center, but almost exclusively in the westerly portion of the storm area, where the cold north and west winds are flowing in.

Again, many investigators to-day have good reason to doubt that the center of the storm is warm to any great elevation or that cyclonic circulation obtains to the top of the air.

In outlining, in a rough and general way, the line of investigation which in my judgment promises to give the most prolific results, not only to the cause of meteorological science, but to the making of more accurate forecasts for the benefit of agriculture and commerce, I will say that we have been for

years taking our measurements at the bottom of this great ocean of air, while the forces which cause the formation of storms, and which influence their intensity and direction of motion, operate at great elevations, or are extraneous to our earth. It therefore seems imperative that systematic exploration should be made of the upper air. Balloon ascensions should be made in the several quadrants of the cyclonic storm and also at the center thereof, especially when rain is falling and the barometric gradient is steep. It is especially important to know the level at which condensation ceases, the depth of the cloud stratum, the temperature gradient, the air pressure and humidity, to a height of four or five miles. Skilled aeronauts with complete and accurate instruments should be placed in the region of severest action at the season of the year when storms are most frequent. They should be held in readiness until the approach of storms typical of cyclonic action, and then from the central office, where the movement of the storm is being carefully watched on the daily synoptic chart, they should be given telegraphic orders to ascend, and their ascensions should be so timed as to secure accurate readings at great elevations throughout the several quarters of the storm. It is believed that information thus secured will establish something like an approach to the true philosophy of storms in contradistinction to the very imperfect theories which too often are hastily approved as demonstrated principles. Instead of erecting a cumbersome superstructure upon the sand, let us endeavor to lay a corner stone upon which to erect something exact enough to be called a science.

In winter the great high-pressure areas which constitute our cold waves should receive the same thorough exploration. Readings at Pike's Peak or Mt. Rainier might be useful in this investigation, but they are

too far removed from the general track of storms and cold waves to furnish the full information desired.

Upper-air explorations may be accomplished by a train of kites carrying automatic instruments, by captive kite-balloons which may be forced nearer and nearer the zenith with increasing wind velocity, or by the ascension of trained observers in free balloons. We must strive for the perfection of appliances and instruments which will, at no distant day, enable us to present to the forecaster the charted synchronous meteorological conditions prevailing at high levels and covering a great area. Mr. McAdie, at Washington, has secured recently some good records with kites at elevations of from 1000 to 2000 feet.

Systematic exploration of the upper air, with a continuation of the studies begun by Professor Bigelow of terrestrial magnetic forces as induced by the solar magnetic field, will be the line of investigation prosecuted during the next two years, and from which it is hoped that results satisfactory to the practical as well as the theoretical man may be obtained.

The Honorable Secretary of Agriculture is in thorough sympathy with all lines of research which can be legally carried on under the Act of Congress constituting the Weather Bureau, and which promise to give results useful to the people.

Harmonious coöperation between the practical worker and the scientific investigator is essential to success. Too often they have found themselves picking out diverging paths. In the future they will work on parallel and converging lines and not far removed from each other, and the result, I am confident, will be beneficial to all. In a great system like ours each worker must be justly recognized for the merit that is in him, whether he be a skilled scientist or an able executive officer, and he should be given his proper place as an in-

tegral part of the great whole which constitutes the efficient Bureau.

A brief retrospect of the forecast work may not be without compensating results in our efforts at future improvements.

Forecasts were begun in the United States about 25 years ago, and have, during the past decade, become of such benefit to the many and diversified interests of the country that with one accord the people now acknowledge their value and applaud all efforts to improve and extend their usefulness. Fifty million dollars is a low estimate of the value of property placed in jeopardy by one West Indian hurricane sweeping up our Atlantic coast.

Predictions were first called 'Probabilities' and were made for districts, each comprising several States, and included a prediction as to the probable change in barometer. Later the prediction as to barometer was omitted. Forecasting by districts was soon shown not to be specific enough as to boundary, and the designations applied were not well understood by the people; hence forecasting by States was adopted.

Forecasts were made only at the Central Office at Washington, and the local observers were allowed to disseminate no other, nor to give public expression to any opinion of their own which might be construed into a forecast. Considering the very limited training of the observers and the lack of all charted meteorological conditions for their study and enlightenment, the wisdom of that regulation could hardly be questioned.

With the transfer of the Weather Bureau to the Department of Agriculture came the inauguration of far more liberal and progressive ideas. The office of Local Forecast Official was created for such observers as had shown special fitness for forecast work, and they were assigned to duty at the more important agricultural, commercial or maritime centers, with instruc-

tions to carefully study the local climatology of their sections, so that products that are indigenous to limited areas, or interests which are of special importance to particular sections, might have such application of the weather forecasts as the intimate personal attentions of a competent local official could give.

The changes enumerated have been carefully tested and found to be beneficial in purpose and worthy of continued and permanent application. Thus has the forecasting system of to-day slowly developed during the past 25 years. Is it not the essential feature of the Weather Bureau? Is it not the nucleus around which all departments of thought and study must rotate and become auxiliary, if the original intent of Congress made manifest by the establishment of a National storm-warning system is to be carried forward to as successful an operation as the present knowledge of the physics of the air will permit? It is hoped that discoveries may be made relative to the controlling and modifying forces of storms which shall raise the standard of forecasting accuracy attained by our most expert officials, who have had all the benefits to be derived from many years of patient and intelligent observation of storms, from the time of their inception in, or entrance within our daily observed and charted territory, until they have been dissipated or have passed eastward beyond our range of vision.

It may be well to consider what class of forecasts can be most successfully made by our more or less empirical methods, the object being to extend the work along such lines of activity as promise the most beneficial results.

As to this proposition it is doubtless conceded by all that when pronounced high and low-pressure areas dominate the weather conditions and the changes in wind, temperature and weather are charac-

terized by such force and degree as to render them destructive to lives and property, a forecaster of average ability and well-balanced judgment is able to make nearly or quite as accurate a forecast as when the air pressure is quite uniformly distributed and all changes of weather are so slight as to be of no importance.

If, then, a destructive frost or cold wave can be predicted as easily as a change of a few degrees in temperature, and if the coming of high winds and gales are as easily foretold as that of a gentle zephyr, it is evident which class of forecasts should receive the greater attention. The public care comparatively little for predictions of moderate changes, and but little credit attaches to the Bureau when such forecasts are verified, but when great heat, cold waves or violent winds are on the programme, a vital interest is felt in the subject, and the accurate forecasting of such conditions is the gauge by which the public measures the usefulness of the Bureau.

Horticulturists and the growers of tobacco and cranberries realize the vast benefit to be derived from accurate frost predictions, and I will give a brief statement of what I believe to be original ideas introduced into the making of frost forecasts while in charge of the State Weather Service of Wisconsin, a State including within its domain the largest area of cranberry marshes in the world, and also including an extensive area devoted to the cultivation of tobacco. Heretofore I believe that only the air conditions have been taken into consideration in the making of frost forecasts—such as pressure, temperature, relative humidity, cloudiness and wind velocity. As a result of my investigations systematically prosecuted for three years I found that the conditions of the soil were equally as important as those of the air.

When the high-pressure area is moving in from the west, clear and colder weather

anticipated, with the probability that the early morning temperature will permit the formation of frost, the most important elements to be considered, in determining whether or not frost will occur injurious to growing crops, are as follows:

First: Has rain recently fallen, and what is the condition of the soil relative to the amount of moisture contained?

Second: What are the natural properties of the soil relative to the slow or rapid loss of heat by radiation?

Third: To what degree of heat has vegetation been subjected during the period immediately preceding?

The early fall frost injurious to tender crops occurs with the observed town or telegraphic minimum temperature ranging from 40 to 50 degrees, because, when the early morning temperature in the town falls much lower than 40 degrees, it is usually so late in the season that all crops are gathered, or if not gathered they have been destroyed ere this condition arrives. At the time then that frost warnings are of most benefit we have to deal with the air at temperatures considerably above the freezing point, and to recall that a deposition of frost requires that the temperature of the top soil, or that of vegetation, be reduced to the freezing point. This, of course, is accomplished by conduction and radiation of heat which takes place more rapidly from the soil and vegetation than it does from the lower stratum of air to the higher.

Anything that will seriously interfere with a rapid loss of heat after nightfall will tend to prevent the formation of frost. Moisture does this, and if the soil be well charged it partakes greatly of the stability of water as to temperature, and cools but little, if any, below the temperature of the superincumbent air, and no frost will occur even though all other favorable conditions of clearness, gentle winds and cool air obtain.

Even a small amount of moisture, say one-half inch of rainfall, will give ample protection if well distributed and precipitated within the 24 hours previous. But when severe drouth conditions are prevalent, injurious frosts may occur when the telegraphic temperatures do not show a reading within ten degrees as low as in the first case.

I believe that when estimating the probability or severity of frost sufficient weight has not been given to the dryness or wetness of the soil and the resultant dissipation or conservation of heat, and I call special attention to the point as one of the means for improving the forecast.

I have in mind two typical cases. In the first a high-pressure area attended by clear and cool weather drifted from the westward until it covered the State. No rain had fallen with the passage of the low-pressure area immediately preceding it; hence the ground was in excellent condition for the rapid loss of heat during the night, and a consequent lowering of the temperature of vegetation to the freezing point. Considerable damage was done to cranberries in unflooded marshes. In the second case a high-pressure area of slightly greater weight and slightly lower temperature covered the region about ten days later, but it was preceded within a few hours by a light but well distributed fall of rain, averaging about one-half an inch, and no frost occurred. In both cases the wind was gentle from the northwest, and the nights were clear. With slightly lower air temperature and higher barometer in the second condition, heavier frost would have occurred than in the preceding case had it not been for the thinly spread moisture of the timely rain conserving heat at the surface of the earth.

Might not this principle be carried further in the improvement of the forecast? Assuming that the caloric energy of the sun is a constant factor, the earth receives each year the same amount or intensity of heat,

and as the atmosphere is warmed mainly by contact with or radiation from the earth, seasonal variations of temperature which are marked departures from the normal might result from abnormal terrestrial surface conditions with respect to the conservation of this constant solar energy over large continental areas. Here the excessive or deficient rainfall during the preceding seasons should receive careful consideration. The subject is one that requires deeper and more detailed investigation than the length of this paper will permit.

I find that the minimum temperatures in cranberry marshes during abnormally dry seasons often fall 15 degrees below the temperatures telegraphed from the cities and towns within a few miles of the marshes. This is due to the fact that when the loose, spongy peat, of which the marsh is composed to the depth of several feet, has dried out, the radiation of heat during the night is very rapid and is not counterbalanced by conduction and connection from the marsh. The temperature, therefore, in cranberry marshes is at all times much lower than that which obtains in marshes composed of heavy black muck, where it preserves a more equable condition, such as is common to air resting over a considerable body of water. A dry cranberry marsh does not, therefore, enjoy that immunity from frost which wet marshes and watery lands get the benefit of. But when the ditches are flooded from the reserve water supply on receipt of a frost warning, the water quickly percolates through the peat composing the marsh, and the rapid loss of heat by radiation is checked and the frost averted.

The degree of heat to which vegetation has been subjected immediately before the frost condition, and the temperature under which it had made its growth, will in a great measure determine the extent of damage to ensue.

By carefully considering the principles herein enunciated, I will say that in 1894 12 out of 14 official forecasts of frost were fully verified—a much greater percentage of accuracy than has ever been attained by simply considering air conditions alone.

WILLIS L. MOORE,
Chief of U. S. Weather Bureau.

*SALIX WARDI, BEBB.**

It is desirable to know much more of the range and specific place of this very interesting willow than is yet known. Having visited it the past season in its native habitat during flowering time, May 10th, at Bonnetterre, Mo., and again when in mature leaf at Pilot Knob and Irondale, Mo., August 19th–20th, also at Washington, D. C., June 18th, I felt, though not without considerable diffidence, that my observations might prove of interest.

If my observations, in some respects, clash with those of our eminent and acute Mr. Bebb, the fact should be ascribed to variation of, or probably to more complete material.

The *S. Wardi* extends northward to within about 37 miles of St. Louis in greater or less abundance, intermingled with *S. nigra* and *S. longifolia*. One, and but one, I discovered growing on the banks of a lake in the Mississippi bottoms, about 8 miles northeast of St. Louis. Hybrids between the *Wardi* and *nigra* occur, but are not common, as is the case with *nigra* and *amygdaloides*.†

Though without question specifically distinct from *nigra*, and seeing it in growth, never to be mistaken for *nigra*, yet it presents several important characters reminding one, again and again, of the latter. Such are the general shape of the leaves, short petiole, persistent stipules, the staminate aments, number of stamens, scales, capsules, but especially the almost absolute corre-

spondence of venation, also the extension of the flowering laterals beyond the base of the rachis, is but the same character often observed in *nigra* emphasized. And yet further, the bark, though distinct, has a resemblance to that of the young stems of *nigra*. Still another reminder of the relationship is the near likeness of discoloration of dried specimens, as well as the color and taste of their infusions.

The following will embrace my observations of its main features: *Salix Wardi* is either a shrub or tree, usually the latter, which rises to the height of 10–15 feet, or exceptionally to 20 feet, 2 to 7 inches in diameter, spreading top, scraggy branches, tending to curve downwards; twigs tenacious, even as to bases, tips winter-killed; bark of stem and main branches are dark grey or blackish (therefore by the natives called 'black willow'), deeply latticed-ridged, resembling that of a youngish black walnut, intensified; it is lichen-covered on its northern aspect. The stem usually stands single, not in clumps as is common with *S. nigra*. The leaves vary from long narrow, to shorter oblong or ovate-lanceolate, matching fairly well, in their range, the forms of both *nigra* and *amygdaloides*, whitish glaucous beneath, pubescent when young, with short petioles; the bases of the leaves range from acute to auriculate, or cordate; stipules large, persistent, variable, roundish, irregular reniform, rhomboidal, oblong, the upper half often serrate, glandless, all obtuse; any tendency of pointing appearing to indicate contamination from *nigra*; young shoots very leafy, rather heavy, intensely whitish hoary pubescent (mostly); aments long, on many leaved laterals which are prolonged beyond the origin of the rachis; capsules smooth, ovate, ovate-conical, globose-ovate, with firm walls retaining shape in drying, line of suture conspicuously marked, slow to open; style and stigma exceptionally undeveloped, the

* Garden and Forest, Vol. 8, p. 363.

† See writer's 'Relations of *Nigra*, etc.' Vol. 6, No. 13, Acad. Sci., St. Louis, Mo.

latter mostly *not notched*. Pedicels stout, long as in amygdaloides. Stamens 4 to 7, mostly 5 to 6, subverticillate, villous at base; scales of staminate as in nigra, short obtuse, villous inside, smooth and *veined* outside.

On the 10th of May about $\frac{1}{3}$ to $\frac{1}{2}$ of the staminate flowers were yet fresh, whilst those of nigra had entirely vanished. They were therefore about 10 days later than nigra, and fully three weeks later than amygdaloides. Some of the capsules were not fully developed, whilst most of nigra had opened.

The discoloration occurring in drying is light or dark brown. The odor given off in handling is strong, rather disagreeable. Many of both staminate and fertile aments were much disfigured and deformed by insect work, or fungous infection. Stamens were caused to look like immature capsules.

Venation: In its very minute reticulation, Wardi presents an almost exact counterpart

of nigra; it lacks however the looping and marginal of the latter.* As to surface venation, while some specimens show raised reticulation moderately, as a rule, this is not a prominent feature.

Infusion: making strong infusions of the bark and leaves of each of Wardi, nigra, and amygdaloides, the first resulted in a liquid of slight bitterness, light brown color; the second, of increased bitterness, also brown color; the third of much increased bitterness, black color, the last two were from fresh material.

In comparing my Missouri with my Washington specimens, I find evidence of probable contamination in the latter series. Such are the shorter pedicels, the tendency to the notching of the stigma, and the greater prevalence of the long narrow-leaved forms.

Finally, having examined several speci-

SYNOPTICAL CONSPECTUS OF S. NIGRA, WARDI, AND AMYGDALOIDES, SHOWING RESEMBLANCES AND DIFFERENCES.

| SALIX NIGRA. | S. WARDI. | S. AMYGDALOIDES. |
|---|--|---|
| Range extended, North and South. | South of 39° latitude | North and West. |
| Size, tree large, branches crooked, ascending. | Small spreading top | large, straight branches |
| Stems, in clumps from a common center. | Single, | Single. |
| bark, young slight ridgy; old flaky branchlets, very brittle at bases branchlets, hardy to tips. | deeply latticed, ridgy tenacious ends, winter-killed hoary pubescent the same, or broader acute to auriculate whitish glaucous | Smooth or roughish somewhat brittle winter-killed glabrous ovate-lanceolate from acute to cordate pale glaucous coarser, more regular very long |
| Shoots, moderately pubescent leaves, oblong or linear-lanceolate base of leaf, acute to truncate. Under surface green | very minute, no marginal the same | obtuse, caducous <i>always glandular</i> |
| venation, very minute, marginal line petioles, short. | obtuse, persistent non-glandular | April 15th 6 to 9 |
| Stipules, pointed, persistent | May 5th | ovate, oblong, acute |
| Stipules non-glandular | 4 to 7, mostly 5 or 6 the same | ovate-conical long, stoutish as in nigra |
| date of blossoming, about April 25th. | ovate, globose-conical long, stout | dark, ashen or lead color fls. and shoots fragrant none. |
| Stamens, mostly less than 6. | both poorly developed light or deep brown | almost free more decided black |
| Scales of staminate, short obtuse. | Strong, disagreeable fls. and frt. deformed the same | |
| Capsules, ovate-conical pedicels, short slender | the same | |
| notched stigma, and style, prominent discoloration, brownish, odor, simply herby | the same | |
| insects or fungous, none, early, insects on leaves, mite galls | the same | |
| infusion, bark and leaves, bitterness slight | brown | |
| infusion, bark and leaves, color, brown | | |

* See writer's paper 'Venation of Salix' 5 Rept. Mo. Bot. Gard., p. 52.

mens of *S. longipes* (now *S. occidentalis*, Bebb) in herb. Nat. Museum; one, an original type specimen by Rugel at Mo. Bot. Gard.; one from Apalachicola bay, Fla. (by Mohr), I venture to predict that after full investigation, the Wardi and longipes will have to go under the same name. In presence of the very high authority of my friend Bebb, I feel fully conscious of the temerity of such assumption; but, if the boldness of an amateur may stimulate him and others to further efforts to solve the entanglement, a good point, at the least, shall have been made in the interest of science.

On previous page is a synoptical conspectus of *S. nigra*, Wardi, and amygdaloides, showing by comparison their resemblances and differences.

N. M. GLATFELTER.

ST. LOUIS, Mo., Oct. 7, 1895.

SCIENTIFIC NOTES AND NEWS.

EDWARDS' BUTTERFLIES OF NORTH AMERICA.

IN the 16th part of his Butterflies of North America, which appeared early in October, Mr. W. H. Edwards has given us one of the most important and interesting of this third series. The three species selected for representation are *Parnassius smintheus*, *Satyrus charon* and *Chionobas gigas*. Every stage of each is represented by the usual wealth and beauty of illustration, which, were we not now accustomed to it, would strike us with amazement, excepting the last species, of which the chrysalis and the last half of the larval life are yet unknown. As to *Parnassius*, no such illustration of a species of the genus has ever been attempted. This Part is particularly valuable, since Mr. Edwards has enriched his text with abundant observations and field notes from his correspondents, so that *Parnassius* extends to 16 quarto pages and *Chionobas* to 11. There is much interesting new matter regarding the formation of the abdominal pouch of the female *Par-*

nassius and figures are for the first time given of Scudder's peraplast, the supposed male implement in its formation. The *Chionobas* portion contains remarkably full comparisons of the habits and distribution of three species of the genus: *gigas*, *californica* and *iduna*, largely from Mr. W. G. Wright's notes, in justification of their belief in the distinctness of these three forms, denied by Elwes.

Another part will presumably conclude the series, but we must express the hope that the indefatigable author will be encouraged by extended subscriptions to begin another series forthwith. Material is not lacking.

THE DAVENPORT ACADEMY OF NATURAL SCIENCES.

THE Academy shows signs of increasing activity. It printed, this spring, *A Summary of the Archæology of Iowa*, by Professor Frederick Starr, of the University of Chicago. This pamphlet, of 72 octavo pages, contains a condensed statement of the substance of more than two hundred scattered articles and papers. It forms a foundation for further study. The Academy now plans a thorough and systematic exploration of the archæology of the State and solicits help from all Iowa workers. A circular stating the plan of the work and giving specific directions to collaborators has been printed and is being distributed. The Academy deserves hearty sympathy in this matter. The present condition and future prospects of the Society are most encouraging. With no debt, it owns a good fire-proof building, possesses important collections in natural history and an astonishingly valuable material from the mounds, and has a library numbering 40,000 books and pamphlets. Its '*Proceedings*,' now in the sixth volume, are known through the world of science. The continuance of publication is now happily assured by a legacy

of \$10,000 just received from Mrs. Mary Putnam Bull, of Tarrytown, N. Y. This gift, a memorial to Mr. Charles E. Putnam and Mr. J. D. Putnam, has been set aside as a Permanent Publication Fund. An effort is now being made to secure an endowment of \$50,000. All who know the history of the Academy will wish it success in this undertaking.

GENERAL.

THE Thirteenth Congress of the American Ornithologists' Union will convene in Washington, D. C., on Monday, November 11th, at 8 o'clock P. M. The evening session will be devoted to the election of officers and the transaction of other routine business.

The meetings open to the public, and devoted to the reading and discussion of scientific papers, will be held in the Lecture Hall of the United States National Museum, beginning Tuesday, November 12th, at 11 A. M., and continuing three days. Information regarding the Congress can be had by addressing the Secretary, Mr. John H. Sage, Portland, Conn.

THE Institute of France celebrated its centenary on the 23d, 24th, 25th and 26th of the present month. On the 23d the members of the five Sections met to receive the associates and the French and foreign correspondents. On the 24th there was a general meeting at the Sorbonne at which M. Poincaré, Minister of Public Instruction and of the Fine Arts, made an address, followed by a banquet in the evening. On the 25th there was a *matinée* at the Théâtre Française and a reception at the house of M. Faure, President of the Republic. On the 26th there was a visit to the Castle Chantilly and a reception by M. le duc d'Aumale.

M. DUCLAUX has been elected director and Dr. ROUX subdirector of the Pasteur Institute.

M. JANSSEN described before the meeting of the Paris Academy of Sciences on October

7th an ascent to the observatory on Mt. Blanc made on September 28th. The parts of a thirteen-inch telescope have arrived safely on the summit and will be mounted as a polar sidereostat. The self-recording meteorograph had stopped running, and M. Janssen thinks that it will require further experiments before the instrument will give satisfactory records. M. Janssen took advantage of the dry air of the summit to examine the solar light with a spectroscope and failed to find any rays of aqueous origin, and regards it as certain that there is neither oxygen nor aqueous vapor in the solar envelopes.

THE Hopkins Laboratory of the Stanford University has just issued the first of a series of bulletins, being a report on the Fishes of Sinaloa, giving the results of an expedition, under the auspices of the laboratory, by Dr. Jordan and several assistants last winter to the port at Mazatlan. A similar expedition, under charge of Dr. C. H. Gilbert, head of the department of zoölogy, with a force of assistants, will be made in December of this year to the coast of Panama. Other expeditions will be sent out from time to time until the Pacific coast is covered.

At the recent meeting of the International Congress of Railway and Marine Hygiene, at Amsterdam, Dr. Zwaardemaker, of Utrecht, urged that railway employees should have their sense of hearing as well as their eyesight tested and that applicants for railway service should only be accepted when their sense of hearing is normal. At the same congress an interesting discussion was held as to whether men wearing spectacles may be employed in the railway service. It seems that in parts of Germany defective eyesight may be corrected by spectacles, whereas in other parts those requiring them may not be employed. In Holland men with abnormal vision are not admitted to the railway service, but, if the

eyesight becomes defective later, spectacles are supplied by the company. It was suggested that engineers and firemen who required glasses should not be employed owing to the difficulty of keeping them clean.

PROFESSOR HALE, of the University of Chicago, and Professor Keeler, of the Allegheny Observatory, are now in Boston engaged in testing the lenses which Mr. Alvan Clark has now nearly completed for the Yerkes Telescope and which he will perfect under their direction.

HERR LUDWIG DÜRR, a German civil engineer, has recently exhibited before the military authorities in London a lamp invented and patented by him. The light is originated by automatic evaporation and overheating of the vapors of ordinary petroleum, and is said to yield a light ranging from 3,500 to 14,000 candle power. With it small print could be easily read at a distance of 120 yards. It is stated that the Dürr light has already been extensively adopted by the Russian and German governments.

THE Paris Academy of Sciences listened to a curious address by M. Émile Blanchard on October 7th. M. Blanchard stated that Lord Salisbury's presidential address before the Oxford meeting of the British Association confirmed the views he had always held regarding the permanence of species. He said that he had been unable to alter the hereditary color of the wings of butterflies, though he had kept them under colored lights of all the shades of the spectrum, and that he himself had often offered in vain to bring before the Academy the results of any investigator who had produced a new species in the animal kingdom!

PROFESSOR MACH, of Vienna, and Professor Wislicenus, of Leipzig, have been elected members of the Kaiserl. Leop.-Carol. Akademie deutscher Naturforscher.

DIE Accademia dei Lincei, of Rome, has

elected H. Wild as foreign member and Ernesto Cæsaro, the mathematician, and Annibale Ricco, the astronomer, as corresponding members.

MR. HOLBROOK CUSHMAN, instructor in physics in Columbia College, died on the evening of October 25th from heart disease, at the age of 38.

DR THOMAS KEITH, a distinguished London physician, known for his original investigations in ovariectomy and in fibroid growths, died on October 9th in his sixty-ninth year.

WE learn from the *Naturwissenschaftliche Rundschau* that Professor Dimitri Brändza, director of the Botanical Gardens in Bukarest, died at Staniel, Moldau, on August 15th. Dr. Riva, the botanist and African explorer, died in Rome on August 24th. On September 4th Professor Dr. Hellriegel, director of the agricultural experiment station, died at Bernberg, at the age of 64 years. On October 1st died Dr. Gustav Wilhelm, professor of agriculture in the technical high school of Gratz, at the age of 61 years, and Dr. Ernst von Rebeur-Paschwitz, astronomer and Privatdocent at Halle, at the age of 34 years.

UNIVERSITY AND EDUCATIONAL NEWS.

ANNUAL REPORT OF PRESIDENT LOW OF COLUMBIA COLLEGE.

PRESIDENT LOW's report was presented to the Trustees of the College on October 7th, and will shortly be published. From it we take the following facts concerning the progress of the University.

Undoubtedly the most important events in the history of the University are those relating to its removal to the new site. Of these events President Low's own gift of a million dollars for the Library Building as a memorial of his father, though only incidentally mentioned in the report, is the most noteworthy. A building for the Depart-

ments of Natural Science has been given by Mr. Schermerhorn, but at least six other buildings are needed. Much work has already been done on the new grounds, and the autumn of 1897 has been fixed as the time when the University shall remove to its permanent home.

The College of Physicians and Surgeons (School of Medicine of the University) will remain at its present site, and the buildings have been enlarged at a cost of \$600,000.

During the year 24,839 bound volumes have been added to the Library, making the total number of books over 200,000. More than \$25,000 was contributed during the year for the purchase of books in addition to special gifts.

Thirty University scholarships of the value of \$150 each have been established for graduate students. In connection with President Low's gift and at his request eight University scholarships and a University fellowship were established. Twenty scholarships are also to be maintained by the Trustees in Barnard College, and the Trustees at their own motion established a professorship to be known as the 'Seth Low Professorship' of American History.

The increase in the number of students in the University continues. The total number of students was

| | |
|--------------|------|
| 1891-92..... | 1573 |
| 1892-93..... | 1641 |
| 1893-94..... | 1805 |
| 1894-95..... | 1943 |

Of these 649 already held degrees representing 136 American and 26 foreign institutions. There were in the School of Philosophy 95 graduate students, in the School of Pure Science 34 and in the School of Political Science 94, and in addition students in the Senior Class of the School of Arts attend these schools.

The total number of instructors was 265, of whom 53 were professors, 8 emeritus professors and 15 adjunct professors. The

most important addition to the School of Pure Science was the appointment as professor of mathematics, under an arrangement with Barnard College, of Professor Frank D. Cole, from the University of Michigan.

The report lays especial stress on the importance of a liberal training as a foundation for professional education. In discussing this question President Low writes:

"Men cannot afford to postpone their specializing in study until so late in life as twenty-two or twenty-three years of age. In England and Germany they begin to specialize at nineteen and twenty, and they ought to do so here. In the newer country it is harder, not easier, to postpone the actual duties of life. It is in this light that I interpret the recent proposition from Harvard to give the Bachelor of Arts degree in three years, and it is certainly in this light that our own action is to be understood of permitting our college Seniors to study under any of the university faculties. Our Freshman Class at Columbia averages at entrance a little above seventeen years of age. * * * * But now that the university has appeared in this country as a place for specialization ideally to be founded on a previous liberal training, it is clear that the liberal training must either be omitted altogether or be confined to those years to which it properly belongs. These years I conceive to be broadly from sixteen to twenty."

President Low is justified in reporting "for the University a year of vigorous, inspiring life, whether regard be had to the current activities of the year, or to the progress made in laying the foundations of the University upon the new site."

GENERAL.

THERE have been two additions of importance to the Stanford Faculty for this year. Dr. H. H. Powers, of the department of economics in Smith College, appointed to the chair of economics and social science; Prof. F. J. A. Davidson, of Toronto University, to the assistant professorship of Romanic languages; the latter appointment being to fill the vacancy made by the resignation of Prof. W. S. Symington, Jr., who takes a professorship in Amherst. Dr. Henry C. Meyers, instructor in chemistry,

resigned to take a professorship in chemistry in Washington State University, to which institution Dr. M. W. Harrington, late of the Weather Bureau, has been called as President, and Mr. Harry Landes, A. M., of Harvard University, to the professorship of Geology.

It has been incorrectly reported in several journals that the University of California will be moved from Berkeley to San Francisco. Mayor Sutro has given 13 acres of ground in San Francisco and the State Legislature has appropriated \$250,000 for the erection of buildings, but these are for the professional schools of law, medicine, dentistry, pharmacy and art, which have always been located in San Francisco.

MRS. CORNELIA A. ATWILL has given \$6,000 to Columbia College for the foundation of two scholarships, to be known as the Stuart Scholarships in the school of arts, in memory of her grandsons, S. B. Stuart, Class of 1880, E. T. Stuart, Class of 1881, both of whom have since died. Mrs. Atwill reserves the privilege of nominating the scholars if so disposed, during her lifetime.

PRESIDENT PETER MCVICAR has resigned the Presidency of Washburn College, Topeka, Kans., which position he has held since 1871.

THE British Treasury has offered to include in next year's estimates a grant of £20,000 to the University College of South Wales. Cardiff and the Drapers company have offered to subscribe £10,000, provided that similar amounts are collected locally.

AMONG recent foreign appointments we notice that Dr. Dogiel, professor of anatomy in the University of Tomsk, has been called to the University of St. Petersburg, and Dr. J. P. Kuenen has been called to the new Harris chair of physics in University College, Dundee. Dr. F. Marés has been promoted to the professorship of physiology at the Bohemian University of Prague and Dr.

Schuchardt has been appointed to a newly established chair of psychiatry at Rostock.

THE Williams Science Hall given to the University of Vermont by Dr. E. H. Williams, of Philadelphia, at a cost of \$13,000 is now nearing completion. It contains laboratories and lecture rooms for the departments of chemistry, physics, biology and electrical engineering. The present Freshman Class, 78 in number, is the largest in the history of the University.

FROM the Oxford University Gazette of October 11th giving the courses for the Michaelmas term, it appears that in mathematics, astronomy and mechanics lectures are given occupying together twelve hours per week; in physics four hours per week; in chemistry eleven hours; in comparative anatomy two hours or more; in physiology five hours; in botany six hours; in geology six hours; in rural economy two hours; in zoology two hours, and in anthropology one hour. Laboratory work is offered in connection with most of these courses, but the opportunities for scientific study at Oxford do not seem to be so favorable as at the leading German and American universities.

CORRESPONDENCE.

THE PROBLEM OF SOLAR MAGNETISM.

THE work of Professor Bigelow (SCIENCE, p. 509, October 18, 1895) upon this subject has reached such dimensions as to command attention; at the same time the conclusions require the abandonment of so many ideas which experimental physicists have considered as representing experimental facts that I venture to call attention to some of the points which will render the new theory difficult of acceptance, by some at least. If Professor Bigelow has foreseen and quantitatively explained away these difficulties we ought to have the explanations.

If meteorology has contented itself (p. 510) with only a consideration of combinations of 'earth's gravity, earth's rotation and equa-

torial insolation,' and has treated the whole question of insolation, it seems to me to have considered, in the last factor, the most important source of energy for disturbances of the atmosphere. We receive from the sun daily sufficient radiant energy to melt a sheet of ice six inches thick (180 ft. annually, Langley). Two-thirds of this is caught by the atmosphere, either on its way in or out. A rough calculation shows this energy sufficient to raise the temperature of the entire atmosphere a little over 3° C. daily. When we remember that this action is concentrated upon a portion of the atmosphere, which is changing daily and annually, and upon certain strata, depending upon their relative humidity, it seems almost superfluous to seek for other forms of energy to account for the activities of the air.

The keystone of the new theory seems to be the assumption that the sun is a magnet and its activity as such affects us to a marked extent. The ratio of the sun's diameter to its distance from the earth is about 1 to 100. It is almost inconceivable that the best steel ball magnet one foot in diameter would affect the most delicate instrument at a distance of 100 feet. Possibly an electromagnet might, but how shall we conceive the sun as an electromagnet, even with the assumption of a solid nucleus and distant envelope. No trace of permanent magnetism has ever been observed in a body that is within several thousand degrees of the sun's temperature; magnetic effects vanish at 800° to 1000° C., except those due to electric currents. Suppose the sun to be a magnet, any distribution of magnetism at all adapted to the new theory would give a field at our distance homogeneous in its distribution in solar longitude, and hence the axial rotation of the sun would not affect the earth's magnetic state; this would be done only by variations from time to time in the intensity or distribution of the sun's magnetism. In no case can the earth's total magnetization be due to the sun's field. It is far too weak to induce such intensity even in the most susceptible metal, much less in such non-magnetic material as the earth's crust. Furthermore, if such were the case the magnetic poles would pass round the earth daily, somewhere between latitudes 60° and 75°.

It would appear that Professor Bigelow attributes to magnetic lines of force entirely novel properties. Properly speaking, lines of force are directions only, and if electricians refer to them as containing energy they really mean tubes of force.

There can be no radiation along a line or tube of force. When the author speaks of the sun as a 'magnet in dynamic operation,' and 'live lines of magnetic force originating in the sun and propagated to the earth in wide sweeping curves,' he uses terms to which students of mechanics and physics have fixed definite meanings, but in a way quite unintelligible to them. Also when variations of terrestrial latitude are attributed 'to the action of stresses in the ether at the surface of the earth, due to the mechanical forces generated in the ether by the transmission of radiant energy.' If we are to admit a new form of radiant energy we must have good cause indeed. No doubt we receive from the sun radiant energy of wave-lengths varying from fractions of a micron to possibly many kilometers, and this varies in nature from actinic to electric, from light to Herz waves of gigantic size.

Again, with reference to the reversal of the curves, Professor Bigelow's magnetic theory seems incapable of explaining such a phenomenon. To doubt that a line of magnetic force is continuous from one pole to the other, in fact, is a closed curve, is to doubt the most fundamental principle of magnetism as at present experimentally established. Electrostatic tubes, or lines of force may be open curves, but the difference between the two cases must be evident. It is difficult to see the connection between these hypothetical magnetic phenomena and the temperature of our atmosphere. It is too permeable and too bad a conductor to catch much of the slow radiant energy, either magnetic or electric.

In view of these difficulties among others are we not warranted in asking a fuller justification of a hypothesis, seemingly based upon curves of small residuals, obtained by a delicate and apparently complicated system of selecting and plotting.

WM. HALLOCK.

COLUMBIA COLLEGE, October 24, 1895.

SCIENCE OR POETRY.

EDITOR OF SCIENCE: In your issue of October 4th, p. 437, under the title, 'Science or Poetry' there is discussed the soundness of the scientific views of three Americans. Referring to one he quotes from his address in SCIENCE, August 23, p. 210, "It can be stated without fear of refutation that every physiological investigation shows with accumulating emphasis that the manifestations of living matter are not explicable with only the forces of dead matter," and he adds, p. 438, "The assertion that this is shown by every or by any physiological investigation is flatly contradicted by most of the investigators." On p. 439 the evidence is called for. I have selected from investigations on what in general comes under the term Osmosis (diffusion, absorption, transudation, etc.), a few references to recent work. This branch of physiology has been chosen for it is in this that the stronghold of the mechanical physiologists may be found. The questions are sharply defined also and experiments may be made on precisely the same object, both in the living and in the dead condition.

Heidenhain, R.: *Versuche und Fragen zur Lehre der Lympfbildung*. Arch. f. d. gesammte Physiologie des Menschen u. der Thiere (Pflüger's Archiv.) Bd. 49, 1891, pp. 209-301. In his conclusions he says: "Da die Triebkraft nicht in dem Blutdrucke liegen kann, muss dieselbe ihren Ursprung aus den Capillarwandung selbst herleiten; es handelt sich um Secretion, nicht um Filtration."

Reid, W.: Osmosis experiments with living and dead membranes. *Journal of Physiology*, Vol. XI., pp. 312-351.

It is shown that the dead differed markedly from the live membranes. With the living membranes the osmosis is more like the secretion of a gland.

Starling, E. A. and Tubby, A. H.: On absorption from and secretion into serous cavities. *Journal of Physiology*, Vol. XVI., 1894, pp. 140-155. "Absorption from or secretion into the pleural cavities is not a mere question of osmosis." *Conclusions*, p. 151.

Chittenden, R. H.: On digestive proteolysis, being the Cartwright lectures for 1894. New Haven, 1895, p. 116. "The view once held,

that the rate of absorption from the alimentary tract stands in close relation to the diffusibility of the products formed, and that non-diffusible substances are incapable of absorption, is no longer tenable. Absorption from the intestine is to be considered rather as a process involving the vital activity of the epithelial cells of the intestinal mucous membrane, where chemical affinities and other like factors play an important part in determining the rate and order of transference through the intestinal walls into the blood and lymph."

Howell, W. H.: *The Physiology of Secretion*. The Reference Handbook of the Medical Sciences, Vol. VI., pp. 363-379. "If the living lung tissue that allowed no liquid to filter through it was killed by heat or any other means, filtration quickly commenced. Similar results were obtained with the frog's intestines and abdominal wall; and if we were justified in applying these results to the other membranes of the body, it would be necessary to explain transudations by something more than simple physical laws." * * * After speaking of some other facts he continues: "Investigations like this compel us to be cautious in explaining the simplest phenomenon of the animal body by physical laws obtained by the study of dead matter."

In the experiments the structure remains the same, and consequently if the results differ the difference cannot be deduced from structure, for the only difference, so far as can be determined, is that it is alive during one experiment and dead at another. If it is urged that the difference is still due to structure which is different in the dead membrane, then life made the difference and there is no ground for disagreement.

In preparing the address it was supposed that a moderate amount of scientific restraint was exercised, and among other qualifications it is stated in the paragraph preceding the one quoted by the critic that, "In brief, it seems to me that the present state of physical and physiological knowledge warrants the assumption, the working hypothesis, that life is a form of energy different from those considered in the domain of physics and chemistry. . . . It, like the other forms of energy, requires a ma-

terial vehicle through which to act. . . . Like the other energies of nature, it does not act alone, etc."

The critic says, p. 439: "Recent utterances seem to show that all the criminals are not among the materialists, and that the dogmatism of biologists must be attacked at both ends of the line."

"In all seriousness we ask, what can fundamental disagreement among those who speak with authority lead to except disaster? Are we not bound to find first principles which will command the assent of all thinking men?"

I supposed it was an axiomatic truth that to have agreement only one man must do the thinking. However, progress has not been most rapid under such circumstances in the past. Perhaps, after all, the best possible antidote to the whole criticism of *Science or Poetry* is the review of Haeckel's Monism, entitled 'The tyranny of the monistic creed' (SCIENCE, N. S., Vol. I., p. 382). There seems in this review to be a protest against any one man setting up as the sole possessor of true doctrine. Here is one sentence from the review: "He (Haeckel) tells us all eminent and unprejudiced men of science who have the courage of their opinions think as he does." As the reviewer did not take kindly to this tyranny of monism, perhaps Haeckel would not include him among the elect in science, but rather would count him also among the poets.

S. H. GAGE.

CORNELL UNIVERSITY.

THE KATYDID'S ORCHESTRA.

TO THE EDITOR OF SCIENCE: The letter in the September 20th issue, from Mr. George M. Gould, seems to indicate that there is considerable ignorance concerning what are supposed to be elementary facts in entomology; and further, that the letter was not submitted to Mr. Scudder, the Entomological Editor, who is well posted in this matter. Mr. Gould asks, "Is Company A composed of males and Company B of females?" The solution suggested is an impossible one, because throughout the *Orthoptera* the females are mute and only the males are provided with stridulating organs. Furthermore, in speaking of the 'Katydid,' Mr. Gould

seems not to be aware that we have at least a dozen species to which this name is applied. We have the 'Katydid' which is *Cyrtophyllium concavum*, which is most generally described, and which makes the typical 'Ka-ty-did' or 'Ka-ty-did'-nt' sound. This species, I believe, does not occur in North Carolina, and the insect to whose sound Mr. Gould has listened was quite a different species from the one that makes loud music in the Middle and Eastern States. The members of the genera *Microcentrum*, *Scudderia* and *Amblycorypha* are all 'Katydid,' all musicians, and each species has a different note. Some of the sounds made by the Locustidæ have been described and set to music by Mr. Scudder, and as a matter of fact every collector in this order soon learns to know, with a fair degree of certainty, exactly what species is making the sound. Mr. Gould's observations are interesting; but they will have very little value until we know of what species he speaks. It is quite certain that the true 'Katydid' is not the species intended.

JOHN B. SMITH.

RUTGERS COLLEGE, NEW BRUNSWICK, N. J.,
October 14, 1895.

Professor Smith is of course correct in taking Dr. Gould to task for suggesting that the female katydid may stridulate, but it is not by any means so sure that *Cyrtophyllus* (the true katydid) 'does not occur in North Carolina,' as believed by him; on the contrary it is at least highly probable that it does, for it is not only found 'in the middle and eastern States,' as he says, but has also been reported from Kentucky (Garman), South Carolina (Saussure) and Georgia (Brunner), as well as in the West from Illinois to Texas. Professor Smith speaks as if the other genera he mentions (which are erroneously called katydids) belonged in the same group with *Cyrtophyllus*, whereas the last belongs to a different family (*Pseudophyllidæ*) and is indeed interesting as the only genus of that family yet known in the United States, although the family is richly represented in Central and especially South America.

The antiphonal rhythm of the two 'orchestras' mentioned by Dr. Gould is very interesting and not altogether unlike what has been observed among crickets; but I am inclined to doubt the

reality of the asserted difference in pitch, because with these locustarians, at least to an untrained ear like mine, differences in distance and consequent sharpness of tone (which latter Dr. Gould specifically mentions) are accompanied by an apparent difference in pitch, which is lost on similar approximation. If Dr. Gould can find two choirs equally loud and distinct, or equally distant and free from intermediate obstructions, accompanied by a real difference in pitch, he should report his further investigations, and further determine precisely what insect is the source of the orchestration.

SAMUEL H. SCUDDER.

A NATURALIST IN MEXICO.

THERE has recently appeared a small volume by Mr. F. C. Baker under the above title which purports to be an account of the expedition of Yucatan and southern Mexico sent out by the Academy of Natural Sciences of Philadelphia in 1890, under the leadership of Prof. Angelo Heilprin. It is based presumably upon the author's notes and recollections of the trip.

As a member of this expedition I consider it my duty to correct several inaccuracies in Mr. Baker's statements, and especially to call attention to the manner in which quotations have been made from the scientific reports of the expedition and other works without a word as to the source of the information, leaving the reader to infer that it is the work of the author. In the preface it is true we are referred to the Proceedings, Acad. Nat. Sci. Phila., 1890-95, 'for full accounts concerning the scientific portion of the expedition,' but the author does not acknowledge any assistance from this source in preparing his volume and makes direct quotations without the slightest comment. His historic account of Yucatan is drawn from Stephens' 'Incidents of Travels in Yucatan,' Vol. I., Chap. iii., as a comparison will at once show, many of the phrases being identical.

Turning to page 80 of 'A Naturalist in Mexico,' we find an account of previous measurements of Mt. Orizaba. The source of this can easily be ascertained by referring to Prof. Heilprin's paper on the subject Proc. Acad. Nat. Sci. Phila., 1890, p. 253-254, as the following quotations will show:

BAKER.

In 1796 Ferrer, by means of angle measurements taken from the Encero, determined the height to be 17,879 feet. Humboldt a few years later measured the mountain from a plain, near the town of Jalapa, and obtained 17,375 feet. He observed, however, that his angles of elevation were very small, and the base-line difficult to level, etc.

HEILPRIN.

Ferrer in 1796, by means of angle measurements taken from the Encero, determined its height to be 17,879 feet. Humboldt a few years later measured the mountain from a plain near the town of Jalapa, and obtained only 17,375 feet, but he observes with characteristic caution that his "angles of elevation were very small, and the base-line difficult to level," etc.

Professor Heilprin very properly places Humboldt's statement in quotation marks, and refers in a footnote to his source of information. Mr. Baker, however, takes Heilprin's statement bodily and Humboldt's with it and uses no quotation marks nor reference whatever! The rest of the account is similar to the above example, but Mr. Baker unfortunately credits Dr. Kaska with making his measurements with a 'thermometer' instead of a barometer as stated by Professor Heilprin.

Immediately following the consideration of the height of the mountain Mr. Baker gives us an account of the birds observed at San Andres. This he has taken directly from my paper Proc. A. N. S., Phila, 1890., p. 213, though it is presented without any acknowledgment or marks of quotation. The following example is sufficient:

BAKER.

The difference between the birds of San Andres and those of Orizaba 4,000 feet below, was marked. Only three species were common to both localities. Nearly all the species belonged to northern genera. In the town the only birds observed were the House Finch, Blue Grosbeak and Barn Swallow, etc.

STONE.

The difference between the birds of this vicinity and of the town of Orizaba 4,000 feet below, was at once apparent. Only three species were seen at both places. * * * Nearly all the species belonged to more northern genera. * * * In the town itself the only birds observed were the House Finch, Barn Swallow and Blue Grosbeak, etc.

While accompanying the expedition mainly as a conchologist, Mr. Baker did render valuable assistance in collecting birds. The scien-

tific names of the species, however, were at that time unknown to both of us, and the subsequent identification, after our return, was entirely my own work. Mr. Baker, however, has quoted my notes and identifications throughout his book as if they were his own. In many cases he has supplemented them by original notes which must have been drawn from memory—a very unreliable source after a lapse of five years. For instance, on p. 28, he says ‘finches were quite abundant,’ while they were in reality very scarce, and p. 32 he records ‘thrushes’ at Glenn’s Camp, while we only saw one thrush in Yucatan, which was at another time and place.

Strangest of all, however, is his account of the Trogon. The bird was shot in the cactus thicket, under the circumstances which he describes, was a Motmot and not a Trogon, as my notebook shows, and the only Trogon that we did collect—in fact, the only one we saw—had not a ‘rose-colored breast,’ but was the yellow breasted *T. cabigatus*.

In describing the effects of the rarefied air during our ascent of Orizaba, Mr. Baker says: “I was seized with most violent symptoms. My head swam, my eyes became bloodshot. * * * * Another of my companions was affected in the same manner.” As Mr. Baker and I were together when we desisted in the ascent I must be the one to whom he alludes, and I can only say that for my part the account is grossly exaggerated, nor did I see such signs of distress in my companion. Indeed, Mr. Baker’s recollections of the trip seem in many respects very dim, as the opening paragraph of his book shows that he has forgotten the name of the vessel upon which we sailed from New York.

On page 97 Mr. Baker takes occasion to ridicule the naming of the mollusks in the Mexican National Museum, referring to one instance as a ‘most ludicrous error.’ There is an old saying that “people who live in glass houses should not throw stones,” and it seems equally ‘ludicrous’ to find on page 123 of Mr. Baker’s book a figure of our eastern kingbird (*Tyrannus tyrannus*) labelled *T. vociferus*; the white tail-band, which is characteristic of the eastern bird and absent in the other, being brought out prominently in the cut; and yet this figure was drawn by the author especially for this work.

It may seem scarcely worth while to call attention to Mr. Baker’s plagiarism as I have done, but unfortunately this is not his first offense, as can be seen on comparing his article on the Round-tailed Muskrat, Proc. Acad. Nat. Sci. Phila., 1889, p. 271, with Mr. F. M. Chapman’s earlier paper on the same subject, Bull. Amer. Mus. Nat. Hist., Vol. II., p. 119, and it seems only right that such practice should be exposed.

WITMER STONE.

ACADEMY NAT. SCIENCES PHILA.

SHELLS AS IMPLEMENTS.

PROFESSOR OTIS T. MASON calls attention, in SCIENCE, October 11, 1895, to an illustration of a perforated shell, said to have been used as a scraper, given in von den Steinen’s work on ‘The Natives of Central Brazil,’ and resembling those figured by Holmes in his ‘Art in Shell,’ Pls. xxvi., fig. 3; xxvii., fig. 1. In shell heaps on the shores of Frenchman’s Bay, Mt. Desert Island, I have found numerous valves of the *Mya arenaria* similarly perforated. The greater part seem to have been so pierced by the hard beaks of the common crow, like those found now on beaches. Others, however, show such a rounded perforation as can only have been made by man, and have the edge artificially smoothed. I have always supposed that such smoothing was caused either by the lashing to it, or the insertion, of a wooden handle, and that the object was used as a spoon or ladle. This seems to be corroborated by the circumstance that the inside of one of these shells is covered by a hard incrustation resembling what is often found upon fragments of pottery vessels that have been used as cooking utensils. The edges of the shells show no indication that they have been used as scrapers.

HENRY W. HAYNES.

BOSTON, October 16, 1895.

SCIENTIFIC LITERATURE.

Canyons of the Colorado. By J. W. POWELL, PH. D., LL. D., formerly Director of the United States Geological Survey, member of the National Academy of Sciences, etc., etc. Meadville, Pa., Flood & Vincent, The Chautauqua-Century Press. 1895.

This is a sumptuous volume of 400 quarto

pages, illustrated by over 300 pictures, besides a number of folding panoramas, not paged. It contains fifteen chapters, of which the first four ('The Valley of the Colorado,' 'Mesas and Buttes,' 'Mountains and Plateaus,' 'Cliffs and Terraces') constitute an introduction in the form of a general description of the region traversed by Colorado River. Seven chapters are devoted to the itinerary of the memorable exploration of the canyon in 1869; four chapters contain the itinerary of the supplementary explorations in 1870; and the final chapter is a summary description of the canyon. The introductory and concluding chapters are based on present knowledge of the geography, geology, meteorology and ethnology of the region; the itineraries are also brought up to date, where there is need, by explanatory paragraphs, and while they are in part reprinted from official and other reports they are enriched by extracts from the original journals not hitherto published.

The valley of the Colorado extends from near Yellowstone Park to the Gulf of California, and from the deserts of the Great Basin to the Rocky Mountain front; it is one of the five principal river basins of the United States and bordering territory. It comprises the low-lying desert plains of the far Southwest, the western slope of the main continental divide and the rugged ranges beyond, together with the vast system of plateaus and mesas lying between mountain and desert. In much of this region the 'great stone book' in which the history of the earth is recorded lies open, and the broad expanse of its rocky pages is the paradise of the geologist; throughout much of the region, too, geologic process is so rapid as to catch the eye of the wayfarer and impress the lessons of dynamic geology. Here it was that Powell perceived the significance of the baselevel, and thereby planted the germ of geomorphology—the 'New Geology,' by which the field of the science has been doubled; here, too, he discovered that the high mountain is the young mountain, and that the crust of the earth is responsive to the transfer of load; here, also, other comprehensive generalizations were made whereby the science of the earth was stimulated and raised to a higher plane. Other American geologists, as

well as Powell, have gained inspiration in this fortunately conditioned field. Gilbert's concepts became masterly as he traversed the rocky tables and rested in the shadow of the cliffs of the Colorado country, and his memoir on the Henry mountain is still the model geologic monograph; Dutton's magnificent generalizations, of which some are even yet hardly grasped by his contemporaries and followers, were formulated in the same inspiring field; there it was, too, that Holmes developed the genius under which art and earth-science were joined, and his portraiture of plateau and mesa and of cliff and canyon (reproduced in part in the present work) remains a model; it was in the depths of the same canyon that Walcott coördinated paleontology and stratigraphy more perfectly than before, and shaped the ideas now bearing fruit in the policy of the federal survey. Through these students and others the influence of the field was spread over the country and world. Thus the valley of the Colorado is classic ground for the geologist; and with respect to physical geology at least, no other part of the earth has contributed so much to the body of the science.

This is the region which is appreciatively yet succinctly described by its original explorer and most philosophic student in the introductory chapters of his book. The description is at the same time sufficiently popular to be followed by the layman, and sufficiently profound to set forth the principles of the science in considerable fullness; and the chapters accordingly serve the double purpose of depicting the salient features of an interesting region in attractive word painting, and of popularizing newly established principles. Perhaps this part of the book might have been made more useful to students by pointing out the extent to which the principles were developed in the field described; but this is only one of the examples, in which the book abounds, of the elevation of well considered facts and principles above the ego.

The valley of the Colorado is hardly less notable in its aboriginal population than in its geologic features. Within its confines the primitive Shoshoni, embracing the 'Diggers' of early explorers, the warlike Apache, the peaceful

Pima, the mystery-loving Pueblo Indians, and other interesting tribes are found, while ruins of cliff houses, cavate dwellings, and plains villages abound. The living Indians discovered by the explorer spoke divers tongues; their habits of life and social customs were diverse; they had ceremonials, beliefs, systems of philosophy, many in number yet more or less closely related among one another, and so widely diverse from those of civilized men as to be rarely understood; their arts were varied yet related, and sometimes different from, though related to, those represented in the prehistoric relics; and the traditions of the tribes indicated extended migrations, peaceful possession alternating with savage strife, and successive occupancy of various districts by different tribes in prehistoric as well as in early historic times.

Thus the ethnic problems were many and interesting, and, since the inhospitality of the district retarded white invasion, the opportunities for ethnic research were exceptionally favorable. Impressed by the characteristics of the native races, the pioneer explorer began studying and recording the native languages, and this line of research was subsequently continued in connection with the federal survey of the Rocky mountain region and still later in the Bureau of American Ethnology; and the study finally grew into a classification of the native races of America north of Mexico on a linguistic basis. Moreover, collaborators were enlisted in the ethnic work as in the geologic studies, and some of these found inspiration in the same district; the Stevensons, husband and wife, enriched the National Museum with collections from different native tribes, and afterward elucidated the mythology of some of the Pueblo peoples; the Mindeleff brothers made extended and fruitful archeologic surveys; Cushing affiliated with the devout Zuñi priesthood, and brilliantly interpreted their thaumaturgic rites and their curiously complicated symbolism and ceremonial; and the influence of the ethnologists, like that of the geologists, extended over the country and the world. Thus the valley of the Colorado is classic ground for the ethnologist, and the dust of the flower bloomed in the desert has fertilized

all other branches of the growing science of man.

In his introductory chapters Powell describes the native tribes and illustrates their characteristics and handiwork as they are known in the light of the science developed in the district, while the itinerary depicts them as they were when first seen by white men. In the description the tribesmen are not dissevered from the district, but treated as an integral part of a natural assemblage of features, like the distinctive flora and fauna—for few of the historic Indians rose to the control of nature, and most of the tribes closely reflected their environment in their habits and institutions. Except that characteristic myths are introduced in the itineraries and that a large number of illustrations pertain to primitive artisans and their art, ethnology is kept somewhat in the background throughout the work, though the ethnology and archeology of the region are happily characterized here and there, particularly toward the end of the fourth chapter.

The itinerary of the first descent of the red-tinted river is a simple narrative of daily events, jotted down by a busy and hard-worked explorer, yet the events collectively form the most remarkable chapter in the history of American exploration; for the writer, albeit buffeted by waves and worn by anxiety for his companions, albeit weary, hungry, drenched and chilled as he wrote, was still a poet-naturalist; and to those who appreciate thrilling adventure, or direct contact with and conquest over nature, the pages are among the most attractive in our language. The little party embarked May 24, 1869, at Green River City, on a river reputed among whites and Indians as too swift and turbulent for passage. Nearly every day was one of peril; oars were broken in the fierce current, boats were overturned in the rapids and crushed against the rocks, apparatus and clothing were swallowed by the waters, food supplies were spoiled and lost, and still the cataracts grew higher, the rapids more terrific; again and again the rushing waters overcame the strength and skill of the boatmen, and the little vessels were engulfed in raging cataracts, sucked down in whirlpools, or rolled over and over on the jagged rocks; once and again leader and men

were washed from their boats to be barely rescued and resuscitated by their mates; yet day after day, for more than three months, the fleet pushed on. The party was a picked one from among the hardest of frontiersmen, and the record of their coolness, courage and fidelity through ceaseless toil and in the face of hourly peril is a picture of the nobility of manhood done in strong colors. But at last the expedition reaches a roaring cataract more forbidding than those already passed, and at the sight of it the spirit of the senior boatman is broken; he and others regard it as certain death to attempt the passage, and decide to trust themselves rather to the inhospitable deserts. There is no mutiny—the situation is far too desperate—all are alike in the valley of the shadow; but all night long the leader paces up and down a little path on a few yards of sand beach by the river side, weighing the chances. At daybreak he decides to go on, and secures anew the wavering allegiance of one after another of the party; but three will not be persuaded, and set out over the rocks—to their death. The leader, with his five companions, shoots the cataract more easily than anticipated, and three days later reaches the mouth of the Rio Virgen, with friendly pioneers already on the lookout for their wreckage.

In his preface the author says, 'The exploration was not made for adventure, but purely for scientific purposes, geographic and geologic, and I had no intention of writing an account of it, but only of recording the scientific results;' and although the chapters are of thrilling interest as a record of adventure alone, yet from beginning to end of the adventurous expedition the primary purpose was kept in view; directions and distances were platted and checked by sextant observations that the river might be mapped; the rocks were studied that the geologic history of resources of the province might be made known; the turbulent stream was studied as a geologic agent, and the effects of storms, tributaries, and changes in declivity were examined to the end that the processes of river work might be better understood. Despite the severity of the trip, few days passed without the record of important scientific observations or generalizations.

The final chapter describes the Grand Canyon as a geographic feature, as a record of geologic product and process, and as one of the most impressive scenic features of the world. "The Grand Canyon is a gorge 217 miles in length, through which flows a great river with many storm-born tributaries. It has a winding way, as rivers are wont to have. Its banks are vast structures of adamant, piled up in forms rarely seen in the mountains" (page 379). The author's impressions of the gorge as a scenic feature are best expressed in his own words:

"The wonders of the Grand Canyon cannot be adequately represented in symbols of speech, nor by speech itself. The resources of the graphic art are taxed beyond their powers in attempting to portray its features. Language and illustration combined must fail. The elements that unite to make the Grand Canyon the most sublime spectacle in nature are multifarious and exceedingly diverse. The Cyclopean forms which result from the sculpture of tempests through ages too long for man to compute, are wrought into endless details, to describe which would be a task equal in magnitude to that of describing the stars of the heavens or the multitudinous beauties of the forest with its traceries of foliage presented by oak and pine and poplar, by beech and linden and hawthorn, by tulip and lily and rose, and by fern and moss and lichen. Besides the elements of form, there are elements of color, for here the colors of the heavens are rivaled by the colors of the rocks. The rainbow is not more replete with hues. But form and color do not exhaust all the divine qualities of the Grand Canyon. It is the land of music. The river thunders in perpetual roar, swelling in floods of music when the storm gods play upon the rocks and fading away in soft and low murmurs when the infinite blue of heaven is unveiled. With the melody of the great tide rising and falling, swelling and vanishing forever, other melodies are heard in the gorges of the lateral canyons, while the waters plunge in the rapids among the rocks or leap in great cataracts. Thus the Grand Canyon is a land of song. Mountains of music swell in the rivers, hills of music billow in the creeks, and meadows of music murmur in the rills that ripple over the rocks. Altogether it is a symphony of multitudinous melodies. All this is the music of waters. The adamant foundations of the earth have been wrought into a sublime harp, upon which the clouds of the heavens play with mighty tempests or with gentle showers.

"The glories and the beauties of form, color and sound unite in the Grand Canyon—forms unrivaled

even by the mountains, colors that vie with sunsets, and sounds that span the diapason from tempest to tinkling rindrop, from cataract to bubbling fountain. But more, it is a vast district of country. Were it a valley plain it would make a State. It can be seen only in parts from hour to hour and from day to day and from week to week and from month to month. A year scarcely suffices to see it all. It has infinite variety, and no part is ever duplicated. Its colors, though many and complex, at any instant change with the ascending and declining sun; lights and shadows appear and vanish with the passing clouds, and the changing seasons mark their passage in changing colors. You cannot see the Grand Canyon in one view, as if it were a changeless spectacle from which a curtain might be lifted, but to see it you have to toil from month to month through its labyrinths. It is a region more difficult to traverse than the Alps or the Himalayas, but if strength and courage are sufficient for the task, by a year's toil a concept of sublimity can be obtained, never again to be equalled on the hither side of Paradise."

Considered as a whole, the book is a monograph on a region classic in geology and ethnology, and a summary history of the development of science in this region. It is at the same time a record, unique in its fullness, of a memorable exploratory trip, the most arduous, save that of Francisco Pizarro on the headwaters of the Amazon, in the annals of America, and one saved from the verdict of foolhardiness only by success. No geologic or ethnologic library or collection of Americana will be complete without it. As a historical treatise the work might have been made more valuable by setting forth the origin and development of great generalizations, and tracing the growth of knowledge concerning the region and its various aspects, though by such treatment its simplicity and unity would have been impaired.

From preface to summary the pages teem with matter-of-fact reason, mingled with poetic imagery, expressed in clear and fluent language. The strong personality of the author can be read only between the lines of scientific observation or generalization, or of the narrative of patient and persevering mastery of natural forces in the canyon. Reading between the lines, the philosophy of the author may be recognized in its practical application. He explored the canyon to the end that knowledge

might be gained; he trained collaborators in geology and ethnology, giving them freely of his acute observations and profound generalizations, to the end that knowledge might be diffused; he would have it that the book should be a monument to his companions in the exploration, including those who faltered at the eleventh hour; and self is lost in the immortality of knowledge useful to mankind.

The publishers have done their part well. The print is large and clear and carefully proof-read; the paper is good, and the illustrations are ample and well selected. Nearly all of the illustrations have been used before, either in governmental publications or in magazines, and to some readers this fact may convey a bad impression; but all of the illustrations have grown out of the work of the author. In some cases, too, it might have been desirable to connect the illustrations more closely with the text by legend or otherwise, and this was perhaps avoided only through desire to economize space. The cloth binding is good, and the binding in leather is excellent. W J MCGEE.

Petrology for Students. An introduction to the study of Rocks under the Microscope. By ALFRED HARKER. Published by Macmillan & Co., New York. 1895. Price, \$2.00.

As the author states in the preface, this text-book is prepared especially for English students, nevertheless, it will be found very useful for those beginning the study of petrography in this country who wish a text-book written in English. No systematic account of the crystallographic and optical properties of minerals has been attempted, and for such information the student is referred to the translation of Professor Rosenbusch's volume on the rock-making minerals. But as an introduction to the study of the rocks themselves a number of useful observations of a general nature are presented upon the characters of minerals in this section, and especially the latest methods of distinguishing the different varieties of feldspar. In treating so complex a subject as the optical properties of minerals in thin sections in such a condensed manner it is doubtful whether the author can meet the wants of a beginner. It

serves, however, as a form of definition of the terms used throughout the book. It would seem that in neglecting the use of those methods of determination based on the optical phenomena observed with converging polarized light the author needlessly weakens the processes of petrographical diagnosis.

In his remarks upon the examination of rock sections the author shows his appreciation of the broad field of the science, which, as he says, is not merely an attempt to discover the composition of a rock, but to unravel its history as well. His clear understanding of the subject is also shown in his discussion of the classification of rocks, especially those of igneous origin. In the present chaotic condition of the nomenclature of rocks it will be difficult for any one who does not succeed in reforming the whole system to classify rocks to his own complete satisfaction or to the satisfaction of any one else. In his attempt at simplification Mr. Harker has shown his independence to a considerable extent, while following in the main the classification of igneous rocks adopted by Rosenbusch, though under a different terminology. Thus massive igneous rocks are subdivided into *plutonic*, *intrusive* and *volcanic*, corresponding to *tiefengesteine*, *ganggesteine* and *vulkanischegesteine*. In many other ways also the author follows the methods and principles of Rosenbusch. Under each of the three great divisions above named the rocks are arranged according to their mineralogical or chemical composition, beginning with the most acid. The names used for varieties of rocks within different families are generally those expressing the mineralogical characteristics of the particular variety rather than those of a geographical character which may already be in common use. But in most cases both names are given. The most noticeable instance of this is in the peridotites.

In substituting the term *intrusive* for that of *ganggesteine*, and in maintaining an independent grouping for certain varieties of intrusive rocks, the author has not improved on the presentation of the case as made by Rosenbusch; and his remarks in introduction of his *intrusive* division are in the nature of an apology.

Nor does his use of the term acid intrusives, in distinction to that of porphyries and por-

phyrites, appear to be fortunate. Diabases are classed as intrusives. Under *volcanic* rocks no distinction is made between older and younger lavas, which certainly seems to be the only proper method of treatment. In this respect the classification follows the English usage. Fragmental products of volcanic action are described in connection with sedimentary rocks.

The descriptions of the various rocks embrace a general definition in mineralogical and structural terms, followed by an account of the constituent minerals and of the microstructure. Illustrative examples are chosen as far as possible from occurrences in Great Britain. The many references to the writings of British geologists and numerous others to the works of foreigners add greatly to the usefulness of the book for more advanced students.

The sedimentary rocks are divided into *arenaceous*, *argillaceous*, *calcareous* and *pyroclastic* kinds. Under the first division the general terms are defined and the characters of the derived grains and of the authigenous constituents are discussed separately. In this way the general characteristics of all arenaceous rocks are given rather than the specific character of any one kind of rock. In the chapter on argillaceous rocks the general definitions are first given, then the characters of the constituent minerals, followed by that of the structure. The description of illustrative occurrences serves to supply the need of some definite picture of different kinds of these rocks. The treatment of calcareous rocks is admirable for so condensed a statement. It deals first with the source and composition of these rocks; then the structure of organic fragments, followed by oölitic structure; the character of the matrix and of deep-sea calcareous deposits. Finally metasomatic changes are described and British examples cited. References to the literature of the subject are numerous and valuable. Pyroclastic rocks are briefly treated. Deposits due to chemical or to organic agencies are described in a few short paragraphs.

Under the head of Metamorphism the author discusses the general principles of the subject, and then describes the changes produced by thermal metamorphism upon the different kinds of sedimentary rocks, and upon igneous rocks

and the crystalline schists. This is followed by an account of the effects of dynamic metamorphism upon the minerals and structures of rocks. Very little space is devoted to the petrographical description of the various kinds of crystalline schists, which are grouped under the heads of *crystalline schists*, *gneisses*, *granulites* and *eclogites*. The basis of classification is structure. The book shows careful preparation, and although the reviewer has taken exception to some features of it he would recommend it to all those beginning the study of petrology.

JOSEPH P. IDDINGS.

SCIENTIFIC JOURNALS.

THE AMERICAN JOURNAL OF SCIENCE,
NOVEMBER.

THE November number of the *American Journal of Science* opens with an article by A. De Forest Palmer, Jr., of Brown University, giving the results of measurements made at Baltimore in 1893 upon the D_3 helium line in the solar spectrum. The observations were made with a large telescope spectrometer with a plane speculum metal grating, the line in question being compared with the best standard lines in the field of view. Seventeen series of measurements were made, an equal number of observations being made on opposite points of the sun's limb to eliminate the effect of rotation. The average of the seventeen values obtained was $5875.939 \pm .006$. A paper by E. A. Hill discusses the new elements argon and helium with special reference to the question as to the atomicity of argon. It is argued that the observations thus far made are not conclusive as proving that it is monatomic; some suggestions are also made as to the relations between the elements named and other elements as shown in the periodic classification of Mendeléeff. Professor W. LeConte Stevens gives the remainder of his address delivered before Section B of the American Association upon 'Recent Progress in Optics;' the earlier part was published in the October number. Wells and Hurlburt describe a series of ammonium-cuprous double halogen salts. Other chemical articles are by Gooch and Evans upon the reduction of selenic acid by hydrochloric acid, and by Gooch and Scoville upon its reduction

by potassium bromide in acid solution. L. V. Pirsson describes some phonolitic rocks from the neighborhood of the Bear Paw Mountain in Montana; one of these contained large crystals of pseudo-leucite, resembling those of Brazil and Magnet Cove, Arkansas. S. L. Penfield and J. H. Pratt give the results of an investigation of a series of minerals of the triphylite-lithiophilite group ($(Fe, Mn)LiPO_3$), which show that the replacement of iron by manganese has a remarkable influence upon the optical properties. Two articles are given by O. C. Marsh, the first upon the Reptilia of Baptonodon Beds of the Rocky Mountain Jurassic; the second upon the restoration of some European Dinosaurs. Four plates accompany the latter paper, giving restoration of the genera: *Compsognathus*, *Scelidosaurus*, *Hypsilophodon*, *Iguanodon*. This paper was read before Section C of the British Association at the Ipswich meeting in September last. The concluding twenty pages of the number are devoted to abstracts, book notices, etc., in various departments of science.

AMERICAN CHEMICAL JOURNAL, OCTOBER.

THIS number of the Journal contains contributions from several laboratories and reviews of new books on chemistry. Two papers by White and Jones on the Sulphonphthaleins contain results of work carried on in the laboratory of the Johns Hopkins University on this class of compounds. Four articles containing results of work in this line have already appeared. White prepared bromine and chlorine products of sulphonfluorescein, but found that the sulphonfluorescein itself could not be prepared by the action of resorcinol on orthosulphobenzoic acid, the product in this case containing four or six residues of resorcinol instead of two. Jones obtained similar results using the paramethylsulphonphthalein. Jackson and Grindley contribute the first of a series of papers upon the action of sodic alcoholates on chloranil. A number of substances were made belonging to a class which had not been very thoroughly investigated before and to which the authors give the name hemiacetals. The discovery of the hemiacetals of the quinones has led them to suggest a possible explanation of the constitution of quinhydrone and

related compounds. They would represent the structure of phenoquinone, for example, by the following formula, in which the phenol is added to the carbonyl groups:

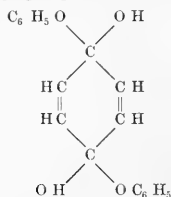

A number of derivatives of this class were made and studied and various lines of research mapped out for the future.

A. S. Miller describes experiments made to determine the results of the action of ammonia on ferric and ferrous chloride. He found that the ferric chloride formed unstable compounds with ammonia, the product formed at ordinary temperatures being $\text{Fe Cl}_3 \cdot 4 \text{NH}_3$. At 100° this becomes $\text{Fe Cl}_2 \cdot 4 \text{NH}_3$ and dissociates when heated higher. The compound formed with ferrous chloride was $\text{Fe Cl}_2 \cdot 6 \text{NH}_3$. Mead and Kremers show that, when so-called 'nitrosopinene' is hydrolysed, carvacrol and not thymol is formed, and as the nitrosopinene is made from pinene we can pass from pinene to carvacrol. Wheeler contributes a preliminary paper on halogen addition products of the anilides. He has obtained bromine addition products of metanitroacetanilide which form substitution products by the loss of hydrobromic acid.

Noyes and Ellis have prepared diphenylbiphenyl synthetically by the action of sodium on bromobiphenyl and shown it to be identical with the hydrocarbon benzerythrene, which is made from benzene by the action of heat. Reviews of several books are given, among them that of Cross and Bevan on Cellulose. A note on helium calls attention to its occurrence in many minerals and also in the free state, its properties, especially its low density and slight solubility, and the analogies in the spectra of helium and argon. J. ELLIOTT GILPIN.

PSYCHE, NOVEMBER.

MR. AND MRS. G. W. PECKHAM give an interesting account of the differences between

two wasps of the genus Trypoxylon in their habits of making and storing nests. H. G. Dyar describes the larva of *Harrisina coracina* found on the vine in New Mexico; and A. P. Morse describes the colors of *Enallagma pictum*, an agrionid, during life. There is also a review of the last part of Edwards' Butterflies of North America and a brief notice of the late Mr. Riley. A supplement contains descriptions of a new genus and several new species of New Mexican bees, with notes on their habits, and a notice of the early stages of *Doryphora lineolata*, both by T. D. A. Cockerell; and the description, with figure, of a new New Mexican Thamnottix, by C. F. Baker.

NEW BOOKS.

- The Scientific Foundations of Analytical Chemistry.* WILHELM OSTWALD. Translated by George M'Gowan. London and New York, Macmillan & Co. 1895. Pp. ix+207. \$1.60.
- Dynamics.* P. G. TAIT. London. Adam and Charles Black. New York, Macmillan & Co. 1895. Pp. xii+361. \$2.50.
- The Structure of Man.* By R. WIEDERSHEIM. Translated by H. and M. Bernard. London and New York, Macmillan & Co. 1895. Pp. x+227. \$2.60.
- An Introduction to the Study of Seaweeds.* London and New York, Macmillan & Co. 1895. Pp. xvi+271. \$1.75.
- Handbook of Grasses.* WILLIAM HUTCHINSON, London, Swan Sonnenschein & Co. New York, Macmillan & Co. 1895. Pp. 92. 75 cents.
- Elements of Plant Anatomy.* EMILY L. GREGORY. Boston and London, Ginn & Co. Pp. viii+148.
- Iowa Geological Survey, Vol. IV.* Third Annual Report, 1894. Des Moines, published for the Iowa Geological Survey. Pp. 461.
- On the Densities of Oxygen and Hydrogen and on the Ratio of their Atomic Weights.* EDWARD W. MORLEY. Washington, The Smithsonian Institution. 1895. 4° pp. xii+117.
- Determinação das Posições Geográficas.* Pp. 57. *O clima do Rio de Janeiro.* Pp. 71. *Eclipses du soleil et occultations.* Pp. 54. L. CRULS. Rio de Janeiro, H. Lombaerts & C. 1894.

SCIENCE

NEW SERIES.
VOL. II. No. 45.

FRIDAY, NOVEMBER 8, 1895.

SINGLE COPIES, 15 CTS.
ANNUAL SUBSCRIPTION, \$5.00.

GUSTAV E. STECHERT'S

Recent Importation of Scientific Books.

ADICKES, DR. ERICH. Kant-Studien. 185 Seiten. gr. 8^o. Mk. 4⁹⁰.

BENEDIKT, DR. MOR. Die Seelenkunde des Menschen als reine Erfahrungswissenschaft. 372 Seiten. 8^o. Mk. 6⁰⁰.

BERMBACH, DR. W. Der elektrische Strom und seine wichtigsten Anwendungen in gemeinverständlicher Darstellung. Mit 90 Abbildungen. 108 Seiten. 8^o. Mk. 2⁹⁰.

BIEDERMANN, W. Elektrophysiologie. 1^{te} Abtheilung. Mit 136 Abbildungen. 440 Seiten. 8^o. Mk. 9.

BOEGLE, DR. C. Die Entstehung organischer Formen. 18 Seiten. 8^o. Mk. 1²⁰.

CAPITAINE, EMIL. Das Wesen des Erfindens. Eine Erklärung der schöpferischen Geistesthätigkeit an Beispielen planmäßiger Aufstellung u. Lösung erfinderischer Aufgaben. 135 Seiten. 8^o. Mk. 3⁰⁰.

DELAGE, YVES. La structure du protoplasma et les théories sur l'hérédité et les grands problèmes de la biologie générale. 878 pages. gr. 8^o cloth. frs 24⁰⁰.

DÜHRING, DR. E. Wirklichkeitsphilosophie, Phantasmenreihe Naturergründung und gerecht freilichtliche Lebensordnung. 554 Seiten. 8^o. Mk. 9⁹⁰.

FOREL, DR. AUGUST. Der Hypnotismus, seine psycho-psychologische medicinische, strafrechtliche Bedeutung und seine Handhabung. 3^{te} verb. Aufl. mit Adnotationen von Dr. O. Vogt. 223 Seiten. gr. 8^o. Mk. 5.

FRICKS, DR. J. Physikalische Technik speciell-Anleitung zur Ausführung physikalischer Demonstrationen und zur Herstellung von physikalischen Demonstrations-Apparaten mit mögl. einfachen Mitteln. 6^{te} umgearb. und verm. Aufl. von Dr. Otto Lehmann. II. Band. Illustriert. 1054 Seiten. gr. 8^o. Mk. 20⁰⁰.

GRIESBACH, PROF. DR. H. Physikalisch-Chemische Propädeutik unter besonderer Berücksichtigung der medicin. Wissenschaften u. mit histor. und biographischen Angaben. 1^{te} Hälfte. Bogen 1-17 mit Figur 1-44. gr. 8^o. Mk. 5⁰⁰.

HAACKE, DR. WILH. Die Schöpfung des Menschen und seiner Ideale. Ein Versuch zur Versöhnung zwischen Religion und Wissenschaft. Mit 62 Abbildungen im Text. 487 Seiten. gr. 8^o. Mk. 12⁹⁰.

HAMPE, DR. JULIUS. Ueber Geisteskrankheiten in Folge Schwefelkohlenstoff-Vergiftung. 51 Seiten. 8^o. Mk. 1⁶⁰.

HANSEN, DR. EMIL CHR. Untersuchungen aus der Praxis der Gährungsindustrie. Beiträge zur Lebensgeschichte der Mikroorganismen. 3^{te} verm. u. neubearb. Aufl. mit 19 Abbildgn. Heft I, 92 Seiten. gr. 8^o. Mk. 3⁵⁰.

HALLIER, DR. ERNST. Die Pestkrankheiten (Infektionskrankheiten) der Kulturgewächse. Nach streng bakteriologischer Methode untersucht und in völliger Uebereinstimmung mit Robert Koch's Entdeckungen geschildert. Mit 7 Tafeln. 144 Seiten. Text. gr. 8^o. Mk. 8⁰⁰.

HITZIG, DR. ED. Ueber den Quärlantenwahnsinn, seine nosologische Stellung und seine forensische Bedeutung. Eine Abhandlung für Aerzte und Juristen. 146 Seiten. gr. 8^o. Mk. 5⁹⁰.

JAHN, HANS. Grundriss der Electrochemie. 311 Seiten. gr. 8^o. Mk. 8⁴⁰.

KROMPECHER, EDMUND. Die mehrfache indirekte Kerntheilung. Mit 9 lithogr. Tafeln. 275 Seiten. gr. 8^o. Mk. 4⁰⁰.

LEHMANN, DR. O. Elektrizität und Licht. Einführung in die messende Electricitätslehre und Photometrie. Mit 220 Holzstichen u. 2 Tafeln. 390 Seiten. gr. 8^o. Mk. 7⁰⁰.

NOLDE, BARON EDUARD. Reise nach Innerasien, Kurdistan und Armenien 1892. Mit dem Bildnis des Reisenden und 1 Karte. 272 Seiten. 8^o. Mk. 4⁵⁰.

Pharmakologie und Toxikologie mit Beiträgen von vielen Ärzten redigirt von A. Brestaniski. 967 Seiten. gr. 8^o. Lubbd. M. 25⁹⁰.

RICHTER, CARL. Die Galvanische Verzinkung des Eisens. Mit besonderer Berücksichtigung der neueren Methoden. Mit 18 Figuren im Text. 48 Seiten. 8^o. Mk. 1⁵⁰.

SCHMIDT, DR. CARL. Das Naturereigniss der Sintflut. Akademischer Vortrag. 63 Seiten. 8^o. Mk. 1²⁰.

WELTER, DR. ADOLF. Die Tiefen Temperaturen, ihre künstl. Erzeugung, ihre Einwirkung auf Tiere, Pflanzen, Microorganismen, etc., sowie ihre Anwendung in der Industrie. 84 Seiten. gr. 8^o. Mk. 2⁵⁰.

ZITTEL, KARL A. VON. Grundzüge der Paläontologie (Paläozoologie). Mit 2048 in den Text gedruckten Abbildungen. 971 Seiten. gr. 8^o. $\frac{1}{2}$ mor. Mk. 25⁰⁰.

ZWAARDEMAKER, DR. H. Die Physiologie des Geruchs. Mit 28 Figuren im Text. 324 Seiten. gr. 8^o. Mk. 9⁹⁰.

GUSTAV E. STECHERT,

810 Broadway, New York.

Macmillan & Co.'s New Books.

Loudon and McLennan.—A Laboratory Course in Experimental

Physics. By W. J. LOUDON, B. A., LL. D., Demonstrator in Physics in the University of Toronto, and J. C. McLENNAN, B. A., Assistant Demonstrator in Physics in the University of Toronto. 8vo, cloth, \$1.90 net.

Ostwald.—The Scientific Foundations of Analytical Chemistry.

Treated in an Elementary Manner by WILHELM OSTWALD, Ph. D., Professor of Chemistry in the University of Leipzig. Translated with the Author's sanction by GEORGE MCGOWAN, Ph. D. 12mo, cloth, pp. 207, \$1.60 net.

Hutchinson.—Hand-Book of Grasses. Treating of their Structure, Classification, Geographical Distribution and Uses. Also Describing the British Species and Their Habitats.

By WILLIAM HUTCHINSON. With Illustrations. 12mo, cloth, 75 cents net.

Laurie.—Facts about Processes, Pigments and Vehicles. A Manual for Art Students.

By A. P. LAURIE, M. A., B. Sc., Lecturer on Chemistry, St. Mary's Hospital; late Fellow King's College, Cambridge. 12mo, cloth, edge cut, \$1.00 net.

Stewart.—An Elementary Treatise on Heat.

By BALFOUR STEWART, LL. D., F. R. S., late Professor of Natural Philosophy Victoria University, Owen's College, Manchester. Sixth edition, revised, with additions, by ROBERT E. BAYNES, M. A., student of Christ Church, Oxford, and Dr. Lee's Reader in Physics. New Edition. 12mo, cloth, \$2.25 net.

Murray.—An Introduction to the Study of Seaweeds.

By GEORGE MURRAY, F. R. S. E., F. L. S. With 8 Colored Plates and 88 other Illustrations. 12mo, cloth, \$1.75 net.

Tait.—Dynamics.

By P. G. TAIT, M. A., Sec. R. S. E., Honorary Fellow of St. Peter's College, Cambridge, Professor of Natural Philosophy in the University of Edinburgh. 12mo, cloth, \$2.50 net.

Wiedersheim.—The Structure of Man. An Index to His Past History.

By DR. R. WIEDERSHEIM. Translated by H. and M. BARNARD. The translation edited and annotated and a preface written by G. B. HOWES, F. L. S., Professor of Zoölogy, Royal College of Science, London. With 105 Figures in the Text. 8vo, cloth, \$2.60 net.

Wilson.—Atlas of the Fertilization and Karyokinesis of the Ovum.

By EDMUND B. WILSON, Ph. D., Professor of Invertebrate Zoölogy in Columbia College, with the coöperation of EDWARD LEAMING, M. D., F. R. P. S., Instructor in Photography at the College of Physicians and Surgeons, Columbia College. With Illustrations. 4to, cloth, \$4.00 net. (Columbia University Press.)

Keith.—Plea for a Simpler Life.

By GEORGE S. KEITH, M. D., F. R. C., P. E. 12mo, cloth, \$1.00.

MACMILLAN & CO., 66 Fifth Avenue, New York.

SCIENCE

EDITORIAL COMMITTEE: S. NEWCOMB, Mathematics; R. S. WOODWARD, Mechanics; E. C. PICKERING, Astronomy; T. C. MENDENHALL, Physics; R. H. THURSTON, Engineering; IRA REMSEN, Chemistry; J. LE CONTE, Geology; W. M. DAVIS, Physiography; O. C. MARSH, Paleontology; W. K. BROOKS, Invertebrate Zoölogy; C. HART MERRIAM, Vertebrate Zoölogy; S. H. SCUDDER, Entomology; N. L. BRITTON, Botany; HENRY F. OSBORN, General Biology; H. P. BOWDITCH, Physiology; J. S. BILLINGS, Hygiene; J. MCKEEN CATTELL, Psychology; DANIEL G. BRINTON, J. W. POWELL, Anthropology.

FRIDAY, NOVEMBER 8, 1895.

LOUIS PASTEUR.

CONTENTS:

| | |
|---|-----|
| <i>Louis Pasteur</i> : H. W. CONN | 601 |
| <i>Pasteur as Illustration of Modern Science</i> : GEORGE BRUCE HALSTED | 611 |
| <i>Determination of the Constants of the Diurnal Nutation</i> : F. FOLIE | 613 |
| <i>Current Notes in Physiography (XVII.)</i> :— | |
| <i>The Labrador Peninsula; Transverse Valleys in the Southern Alps; A Swiss Landslide in the Glacial Period; Valleys in the Plateau of the Ardennes; The Rivers of Spain</i> : W. M. DAVIS | 617 |
| <i>Scientific Notes and News</i> :— | |
| <i>Field Work of the U. S. Geological Survey; The 'Institut Pasteur'; The Phenomena of Friction; General</i> | 619 |
| <i>University and Educational News</i> | 625 |
| <i>Correspondence</i> :— | |
| <i>Experimental Psychology in America</i> : WILLIAM JAMES, GEORGE TRUMBULL LADD, J. MARK BALDWIN, J. MCKEEN CATTELL. <i>Radiolarian Earths of Cuba</i> : ROBERT T. HILL. <i>Erect Vision and Single Vision</i> : JOSEPH LE CONTE | 626 |
| <i>Scientific Literature</i> :— | |
| <i>Hancock's Mechanics and Hydrostatics; Glazebrook's Mechanics</i> : R. S. WOODWARD. <i>Fourteenth Annual Report of the U. S. Geological Survey; Rolker's Production of Tin</i> : J. F. KEMP. <i>Oliver's Natural History of Plants; A Traverse le Caucase</i> : ELIZABETH BRITTON | 630 |
| <i>Societies and Academies</i> :— | |
| <i>Biological Society of Washington</i> : F. A. LUCAS. <i>The Academy of Science of St. Louis</i> : A. W. DOUGLAS | 635 |
| <i>New Books</i> | 636 |

NEVER has the world been called upon to lament the death of one whose life was so full of gifts to humanity as that of Louis Pasteur. Others have lived with equal genius, others there have been whose influence upon thought has been equal or greater. Others have achieved an equal reputation from achievements of various kinds; but no other man in the history of the world has given to mankind so many valuable gifts as those which have come from the labors of Pasteur. That Pasteur possessed great genius is manifest, but yet it was not wholly genius that explains his marked preëminence, for a certain modicum must be attributed to the timeliness of his work. His greatness was due in a measure to the fact that early in life he had the fortune to have presented to his attention and the wisdom to seize upon great problems for solution. He early seized for his own an almost new field of research and brought to this new field an equipment entirely different from that which any other scientist had possessed. Pasteur is regarded as the father of modern bacteriology, but we must remember that he was not a pioneer in these lines of work. There was hardly a problem that he studied which had not been already recognized, and even studied to a greater or less extent by his predecessors; but at the same time there was not a single problem which Pasteur undertook to solve

MSS. intended for publication and books, etc., intended for review should be sent to the responsible editor, Prof. J. McKee Cattell, Garrison on Hudson, N. Y.

Subscriptions and advertisements should be sent to SCIENCE, 41 N. Queen St., Lancaster, Pa., or 41 East 49th St., New York.

which was not when he undertook it in a most crude, unsatisfactory condition, and when he left it in its almost perfect form. It was in reaping fruits where others failed, and in perfecting the work which had been begun by less competent scientists, that Pasteur's merit lies. Others discovered facts, Pasteur determined laws.

In looking over the life of Pasteur as a whole we are struck forcibly with two characteristics. The first was its almost uniform success. Doubtless Pasteur occasionally failed in his experimental work. But of this the world has known nothing for his conclusions seem to have been always correct. So far as Pasteur has appeared before the public from the beginning to the end of his career he has enjoyed an uninterrupted success. The French people have slowly learned to recognize this and finally acquired such a confidence in him that it has been a popular saying which has met all criticisms that '*Pasteur never makes mistakes.*' This unique testimony of public confidence is unexampled, but it seems to have been well deserved, for certainly no scientist has ever held such a position before the public and made so few mistakes. This is the more remarkable when we remember that he was working in an almost unexplored field. The reason for this uniform success lies primarily doubtless in the nature of the man; but not a little of it we may attribute to the fact that in his early training Pasteur was a chemist rather than a biologist. While Pasteur's reputation will rest upon his work in biology he was educated as a chemist, and to this education we may attribute no little of the uniformity of the success of experiments. The science of biology is extremely inexact. Owing to the complicated conditions of life one is ever expecting to find exceptions to the general rules and our scientists have found it utterly impossible to lay down absolute definitions or any absolute lines of

distinction between groups in biological phenomena. The very essence of biological science is the fact that the phenomena grade into each other. Influenced by this fundamental principle biologists have commonly fallen into a habit of slackness in dealing with phenomena. Knowing that whatsoever law they may discover will be sure to have its modifications, its variations and its exceptions, they inevitably get into the habit of feeling that an approximation toward accuracy is almost sufficient. Now the peculiar nature of the field of experimentation in bacteriology demands above all things most rigid accuracy. His training as an analytical chemist gave to Pasteur a recognition of the importance of exactness. One who has carried on experiments in molecular physics recognizes that failure is sure to result from inaccuracy, and it was the fact that until he was 30 years of age Pasteur was trained in this kind of accurate experimental manipulation that, when he turned his attention finally to biology and problems connected with the microscopical world, his methods of experimentation and the results of the experiment showed at once a vast advance over those of all of the biologists which had preceded him. For the first time accuracy began to be seen in this field.

A second striking feature in Pasteur's life was its dramatic character. One hardly looks for the dramatic in the achievement of scientific results. But Pasteur was a Frenchman, and, although thoroughly modest, he was, like other Frenchmen, alive to the advantage of public demonstrations. As we look through his life we can see him taking many and many an opportunity of presenting his scientific results in as dramatic a style as possible. Meeting with opposition almost constantly during the years of his active investigations, time and time again he planned public tests in which his results should be brought before the

public eye for demonstration in such a fashion as to appeal in a striking manner to the world. No other scientist has ever achieved so many brilliant public successes. We must above all things learn from Pasteur's life that after all the chief reason that his reputation advanced so rapidly in the comparatively few years of his active work was in no small measure the fact that he had the wisdom to see that it is to the application of science to practical life that the world in general gives the greatest admiration. There is ever a tendency among scientists to belittle one of their number who attempts to apply to practical life the results of research. In spite of every plea that may be made for pure science it is the application of science to the life of man that has the greatest interest to mankind. As we look through Pasteur's life and study the growth of his wide reputation we shall find that this reputation was largely founded upon the brilliant epochs in his history where he applied to practical subjects the results of the scientific investigation. The advance in his reputation came at those occasions when the public learned of his work because it had been applied to something that interested the world. The homage that the world has given to Pasteur testifies to the value of practical science, testifies to the truth of the position that pure science is of value to man chiefly as it can be applied to facts that influence practical life. While, then, applied science is frequently mentioned with a slight disdain by the modern advanced scientist, it is well to remember that Pasteur, whose reputation as a scientist has perhaps outranked that of any man of the last 50 years, made his reputation and achieved his world-wide fame because he applied to the practical things of life the discoveries revealed to him by his microscope.

The active part of Pasteur's life was so full of investigations in many lines that it

is impossible in a brief review that they should receive the weight which they deserve. Only the most important of them can be here mentioned, a selection being made of those upon which his reputation has been chiefly built. Pasteur received an early training as a chemist, and the first work of his life was chemical. Until he had reached about the age of 32 the work he had been doing had been mostly in the line of molecular physics, and certain papers upon the structure of crystals appeared from his pen which even in those early years showed signs of genius. He would have probably made his mark as a chemist had not his attention been turned to a more fruitful field. In 1854 he was appointed Dean of the University of Lille, and it was at this place that his attention was first turned in the direction which subsequently made him famous. A simple incident led him to the study of fermentations in the manufacture of certain chemicals. The crystallization of tartrates had earlier interested him, but now he noticed that tartrate of lime had a tendency to ferment. This fact attracted his attention and led him into observations and experiments upon the nature of the fermentation of tartrates. These experiments demonstrated to his microscope the universal presence of living organisms in the fermenting material. Finding these fermentations universally accompanied by living organisms it appeared to him as probable that the fact must be part of some general law. It was not a pure accident that living organisms were present, but in some way he believed there was a connection between the fermentations and the presence of the organisms. A general law he formulated, and reached the inference that fermentations in general are produced by living organisms, microscopical in size but of very great potency. This conclusion was, of course, a simple inference as yet undemonstrated, but it was the in-

ference which started Pasteur along the line of his experiments in fermentation. It was the guiding star of Pasteur's life. From the moment the inference was drawn until his death this law, that fermentations, putrefactions and all similar chemical changes were produced by the growth of microorganisms, was the basis of every line of investigation which was undertaken by him. Every new problem in his life was attacked by him from this standpoint. The great success of Pasteur's work lay in the fact that his guiding principle was a correct one, his great merit in his wisdom in early adopting it as a law, and his genius in demonstrating it. If he had drawn an inaccurate conclusion from these early experiments he might in time have corrected the error, but we must look upon the fact that he had the wisdom to draw a correct inference from this first work as the foundation of Pasteur's success in life.

Pasteur now became interested in the subject of fermentation. His home was in one of the important seats of fermentative industries, and study of fermentation as a general phenomena at once received his attention, not only from its general interest, but as especially appropriate to his life at Lille. He was thus led away from the line of pure chemistry into biological work, but the change was almost imperceptible. Up to the time when Pasteur began his studies fermentation had been regarded as a chemical phenomenon, and it was natural that a chemist should study it. In the few decades that preceded the work of Pasteur, fermentation had been carefully studied by a number of our chemists and microscopists. While different theories had been advanced, the theory of fermentation, which was almost universally held at the time when Pasteur began his experiments, was that of the chemist Liebig and was a purely chemical theory. In accordance with this theory of Liebig, fermentation is

simply the chemical decomposition of bodies produced by the unstable equilibrium of their molecules. This theory held that the molecules of fermentable materials were very unstable and were easily broken to pieces into simpler compounds. The ferment was held to be simply an exciting cause which started this chemical decomposition. Fermentation was thus a purely chemical subject at the time when Pasteur began his studies, and the first work which he attempted was to show that the chemical theory of the scientists of his day should be replaced by the physiological or biological theory which he was convinced from his experiments was the correct one. Upon this task he set himself at once, and by the study of the lactic fermentation of milk, the butyric fermentation of milk, the acetic acid fermentation in the manufacture of vinegar, and by the numerous careful experiments along these various lines which he devised in his laboratory, it required only four or five years for him to undermine completely the chemical theory of Liebig and to put in its place, on a somewhat unstable basis at first, perhaps, the theory that all types of fermentation are organic in their nature and produced by the life of microscopic organisms. Even at this early day we can see his recognition of the value of the practical application of science, for among the very early pieces of work which he performed was the study of the acetic acid fermentation in the making of vinegar, and by a practical application of his results to this industry he developed a vast improvement in the manufacture of vinegar and a great cheapening of the process.

Pasteur had thus made something *his own*, and at this date, in the vicinity of 1860, he became recognized as the exponent of the biological theory of fermentation. From this time he progressed rapidly. The fermentation of wine next claimed his attention. Here was a second fermentative indus-

try in which unexplained difficulties were constantly occurring. He soon found the cause of the various failures of the vintner by which were produced many of the so-called 'diseases of wine.' These diseases he found were all due to the presence of improper micro-organisms during the fermentation instead of the pure fermenting yeasts, and he quickly devised a remedy for them in a process that has subsequently been known by his name as the process of *pasteurization*. This method of preventing the evils involving the heating of wine, was received with great opposition on the ground that the heating injured the flavor. After a great deal of more or less violent disputing on the matter Pasteur arranged for a public test of the question by getting together a large number of experts and convincing them against their will, by ingeniously devised deceptions, that they were unable to distinguish between wines that had been pasteurized by his process and wines that had not been subject to heat. Having previously shown that the method of pasteurization was almost a sure remedy against the various diseases, this first public demonstration was thus a brilliant success and at once obtained for his method the acceptance of the vintner.

Meantime he had been giving his attention to the vexed problem of the last two or three centuries, namely, the question of spontaneous generation. Believing, as he did, that all fermentation was caused by micro-organisms, it was a foregone conclusion that he would be an opponent to the view of spontaneous generation. The studies upon fermentation which he had been carrying on, and his accurate methods, trained him especially well for this subject of spontaneous generation, and the experiments which he instituted brought this question into the condition of demonstration. The experiments of early scientists were repeated by him with greater care; many new ex-

periments of his own were devised; the microscope was brought into requisition in new ways. A brilliant conclusion was reached, that by the exercise of sufficient care all traces of life could be avoided and no spontaneous generation ever occurred. It is true that the conclusions of Pasteur were not at once everywhere accepted. In England, particularly, objectors arose who advocated a belief in spontaneous generation, and these objections were not silenced until the English physicist Tyndall took up the experiments that Pasteur had been making and even more satisfactorily reached the same conclusion. But Tyndall's results were only those that Pasteur had reached before, and we recognize to-day that the only basis of the objections that were made to Pasteur's conclusions was the inaccuracy and lack of care with which his opponents performed their experiments. With brilliant rhetoric and loose experimenting, spontaneous generation was still advocated, but the disproof was given by Pasteur in spite of the fact that opposition still arose after the disproof had been reached.

But now Pasteur's attention was to be turned again and in a direction that again changed his whole life and has revolutionized modern medicine. One of the great industries of France is that of the silk-worm raising. About 1850 there appeared upon the silk-worm farms a disease of the silk worm known as *pèbrine*. This disease spread rapidly from farm to farm, greatly reduced the productions of the silk-worm farms and actually threatened the entire destruction of the silk-worm industry. From 57,000,000 pounds per year in 13 years this industry had fallen to 8,000,000 pounds, all because of the great devastation produced by this disease. Many had been the attempts made to cure it and many the attempts made to discover its cause. Men with a reputation greater than that possessed by Pasteur, at the time, had

attacked the problem and failed. In the year 1865 no remedy had been discovered, no cause was known and the silk-worm industry was threatened with immediate destruction. Pasteur was asked to investigate the question and at first refused to do so. His success in the study of fermentation had opened to him a prosperous career; he knew nothing whatsoever of silk-worm raising, and he was afraid that the investigation, even if successful, would lead him too far from his own chosen line of work. He was, however, over-persuaded and finally accepted the task of investigating *pèbrine*, little thinking that it was only the continuation of his studies on fermentation and that along the line opened to him by this investigation he was to find his life work and world-wide reputation. Pasteur undertook the investigation of *pèbrine* already prepared for his discoveries, for living micro-organisms were for him potent agents in nature. He very soon discovered that the cause of the disease was a microscopic organism living in the moth. He was not the first to discover this organism, for others had seen it and described it. That Pasteur succeeded where others failed was due to the fact of his belief in the powers of the microscopic world. Others regarded these organisms as of no importance, but Pasteur had become so imbued by his study of fermentation with the important agency of microscopic organisms that the very first question that he asked was whether living bodies were not the cause of the disease that he had been set to investigate. If organisms could produce fermentations in dead material why might they not produce disease in living creatures? The result of his work here we need not dwell upon. It was a brilliant success. It demonstrated that the disease was caused by the organisms and it devised a remedy against the trouble by simply breeding from healthy moths. The world laughed at him;

those interested in the silk worm industry refused to adopt his methods as those of a fanatical microscopist, and too simple. He met at first with nothing but opposition, but the man arose to the occasion and so sure was he that he was right that he again arranged for a public demonstration. An abandoned silk-worm farm was put into his hands and, although at the time an invalid and unable to travel by ordinary means, he had himself transported across France and personally directed the work on this silk-worm farm, although he was unable to do anything himself. It is not, perhaps, generally known that from this time to his death Pasteur was partially paralyzed and unable to perform the work of his own experiments. There is something truly pathetic and dramatic as we think of him, an invalid, simply capable of directing others in their work, and yet fired with the belief that he was right and with the determination to convince the world that he was right. Again Pasteur's genius demonstrated itself and, by using his simple remedy, in a short time this silk worm farm, abandoned because of the presence of the disease, was restored to a condition in which it was one of the best paying silk-worm farms in France. The disease was practically eradicated from it. With a bound Pasteur's reputation spread throughout France and the world. The silk-worm industry in France began to adopt his methods at once and rapidly assumed its old condition of prosperity. From now on the Frenchmen were ready to accept almost anything that Pasteur would say. He had saved them their beloved silk-worm industry and had been the means of saving to the peasants of France a sum of money almost beyond belief.

The next important work in Pasteur's life was his investigations upon the subject of the fermentations of beer. The Franco-Prussian war and its results had deprived

the French people of their beer makers, who had been largely German, and when the French people began to make their own beer they found themselves for awhile in difficulties. In spite of careful methods various imperfections in fermentations were of frequent occurrence. By this time the French public had become confident in Pasteur's abilities, and it was only natural that he should be requested to find the solution for this puzzle. As usual, success attended his efforts. His microscope soon showed him that the trouble was due to the use of impure yeasts. The brewer's yeast was liable to be mixed with various species of bacteria as well as improper species of yeasts, and his genius soon showed methods of removing the difficulties and bringing the fermentative industry into a condition of uniformity. Upon the basis of these experiments has been founded the whole of our modern brewing industries. The large brewery of to-day is impossible without the microscope, and to the stimulus given by these discoveries of Pasteur has been due the great centralization of brewing.

The next problem that attracted the attention of Pasteur was the dreaded anthrax. For several years this devastating disease had been the subject of scientific investigation. Already its connection with micro-organisms had been made probable and indeed had been demonstrated. Many problems had been solved, but many still remain to be solved in connection with this pestilence of the agriculturist. As usual Pasteur began at the beginning taking nothing for granted, even of the facts that had been essentially demonstrated. His experiments resulted in a more complete demonstration of the relation between the anthrax bacillus and the disease, showed the method of action of the germ, demonstrated the source from which it was frequently derived by cattle, differentiated

between this disease and one or two others closely resembling it among animals, disproved all of the objections that had been raised by those who disbelieved in the causal nature of the bacilli, and, in short, brought this subject upon the same sure foundation as that of *pèbrine* which he had so triumphantly solved ten years before. Nor was this all. The greatest discovery or his life was to follow. To Pasteur's peculiar trait of mind it was not enough to discover the cause without searching for the remedy. It was the *practical* question which appealed to him. Pasteur recognized the fact that in the human race one attack of an infectious disease frequently renders an individual immune against a second attack. He also remembered that protection against small pox had been known to be produced by vaccination. Acting upon these suggestions the question arose in his mind whether it were not possible to give to domestic animals, subject to this devastating disease, a milder type of the disease in question, from which they should readily recover, but which would give them immunity against a second attack. The principle was a new one and outlined a new, bold plunge into the mysteries of nature. It was not, however, in the investigations of anthrax that the remedy first suggested itself, but rather in a side investigation upon the subject of another germ disease known as fowl cholera. Every one is familiar with the results. He discovered a method of rendering the invading organisms of fowl cholera so impaired in their action as to be unable to produce death, giving rise, on the contrary, simply to a slight indisposition; but demonstration soon showed him that this slight indisposition was followed by immunity against the more severe disease. To anthrax he turned the same line of investigation, and after patient, laborious search discovered a means of rendering the anthrax

germ impaired in its vigor. His preliminary experiments convinced him that he had achieved success, and then came one of those dramatic public exhibitions in which Pasteur so delighted and which have so impressed the world. Almost before the public had learned that he had obtained a possible method of preventing this dread disease among agriculturists, Pasteur made arrangements for a public test of his method, and in the presence of an audience of some 200 experts made up of physicians, veterinarians, Senators, prefects, farmers, members of the French Academy and others of high standing, he demonstrated by a simple experiment, lasting about a week, that he could with unerring certainty prevent cattle from acquiring anthrax; that he could give to them a practically absolute immunity against this almost surely fatal disease by infecting them with a very mild indisposition a few days before. The effect upon the audience was electrical and their enthusiasm knew no bounds. Pasteur's experiments spread at once over the world, and from this further practical application of his scientific research his reputation made another advance. His anthrax vaccine was distributed through the civilized world, was used by grazing communities everywhere, and it has been thought to have saved the life of hundreds of thousands of cattle. The greatness of this discovery can hardly be appreciated to-day. It was a logical discovery of a new method of meeting disease. While other even more valuable discoveries in the same line have followed and are still to follow, none can equal in significance this first application of the studies of the microscope to the treatment of disease.

Following the work upon anthrax various other lines of bacteriological research connected with diseases of animals attracted his attention and demanded his time. It was not, however, until he had attacked

the problem of the most dreaded of all human diseases, hydrophobia, that he again attracted the public eye. His experiments upon hydrophobia were, perhaps, the boldest in the line of experimentation that had ever occurred, for here for the first time in history laboratory experiments were transferred to the human being. Hydrophobia had fascinated Pasteur for a long time. Experimental work had shown him that the disease was not a purely nervous excitation, as had been claimed, but that there was an actual disease under this name. Experiments showed him further that the disease bears every similarity to infectious germ diseases, although neither he nor anyone else, even to the present day, have succeeded in demonstrating the organism which produces the diseases. Experiments upon dogs and rabbits in his laboratory followed each other rapidly, and with his usual genius he devised many a method of hastening the experiments and of rapidly reaching results which would normally take months. His success with other diseases made him ambitious also to find a method of preventing this disease, and, while the methods which he had used in fowl cholera and anthrax proved useless in the case of hydrophobia, the same general line of work led him finally to a method of inoculating animals which rendered them immune against this disease. Not only so, but the same method when applied in a slightly different way was found to be efficacious in warding off the disease in an animal which had been previously inoculated therewith. He found himself able with certainty to inoculate an animal with hydrophobia and then, by treating him with the various subdermic injections which he had devised, prevent the appearance of the disease which would have otherwise inevitably occurred. Laboratory experiments were a success, and next the bold step was taken of applying to mankind laboratory methods, which had been hither-

to tried upon animals alone. A youth who had been severely bitten by an unquestionably rabid dog was brought to him at his laboratory. The youth's life was despaired of by the physicians, inasmuch as with certainty he would develop hydrophobia. Under the circumstances Pasteur felt justified in trying upon this youth the experiments that had succeeded with dogs and rabbits. The experiment so far as could be demonstrated was a success. The youth failed to develop this disease. But for a final demonstration that his methods were successful was required a long series of public experiments which were not to be obtained by any one dramatic incident. To obtain such testimony no means appeared to be possible except to announce to the public the discovery of a method of preventing hydrophobia. Such an announcement was made by Pasteur. The public had such unlimited confidence in the man that they at once accepted the conclusion as correct. Certain it is that no one else could have taken the public into his experiments, but his uninterrupted success in previous years gave all a belief that he had made no mistake here. Opportunities for experiment began to multiply, and scores and then hundred of individuals who had been bitten by animals, either rabid or supposed to be rabid, flocked to the laboratory of Pasteur to be treated by his method. The experiments thus begun have continued for eight years, and even yet can hardly be considered as concluded. The opinion of the public, and especially of the medical world, has vibrated from one side to the other. At first Pasteur's conclusions were accepted as probable simply on the basis of the great reputation of the man, and the fact that Pasteur made so few mistakes. Later, flying to the other extreme, the whole efficacy of the method as practiced by Pasteur was doubted. Most violent opposition arose, and it is thought

that this opposition contributed to undermine Pasteur's health and check his active life. Later again the world became slowly convinced, by the accumulating testimony in his Institute, that here too no mistake had been made. At the present time there is hardly a question that Pasteur's methods, even in the case of hydrophobia, have demonstrated themselves as successful. While statistics are a very uncertain kind of evidence, one cannot read of the success which has attended the inoculation in Pasteur's Institute for eight years without being convinced that Pasteur's methods are correct. In his Institute have been treated several thousands of cases of persons bitten by animals supposed to have been rabid, and among those that have been treated the number of deaths has only been a trifle over one per cent. With this exceptionally small percentage, even after we say everything possible as to the uncertainty of statistics, we can hardly question that truth underlies these methods, and that Pasteur's last great work was as successful as those of his earlier years.

This work upon hydrophobia was the last piece of work which we have directly from Pasteur's own personality. A Pasteur Institute has come, and from that Institute has come, and is still coming, a series of investigations along the lines that Pasteur began, which are yearly adding not only to our scientific knowledge, but to our practical method of dealing with disease. While Pasteur's name is no longer attached to these individual researches, the master's hand gave the inspiration for them all. For several years the experiments have all been in the hands of his assistants. While we have looked upon them as his assistants, we must recognize them as independent and as having achieved their own reputation, but nevertheless, we must feel that the work that has come from Pasteur's Institute, and that will for a number of years be given to the

world from that source, must be directly or indirectly attributed to the inspiration of the master for whom the Institute was founded.

The world's debt to Pasteur we cannot estimate. His financial gifts we can realize, when we remember that he saved the silk-worm industry, that he taught the vintners how to make wine, that he established the fermentative industry the world over, and that he gave to the agriculturists a method of preventing anthrax, we can see that the financial value of his life to the world was far beyond that of any other person that ever lived. The debt of theoretical science to him is equally great, though not measurable in any terms. He disclosed a new world; he discovered a new series of phenomena taking place below the realm of human vision and he opened to the world a new field of science. To medicine again his gifts were beyond measure. To him more than any other is due the demonstration of the germ nature of disease, and to his work we owe our hopes for medical science in the future. The practice of medicine has been almost purely empirical. To-day we are hoping that it is gradually becoming a matter of science. As we know the causes so we can search for the remedies against disease, and to Pasteur is due the first attempt to place medicine upon a scientific basis. Surgery has already become a science, and this too is indirectly attributable to him. While modern surgical methods were developed by Lister, the methods of Lister were devised as the result of the study of Pasteur's work in fermentation. Pasteur has opened to us a new world and given to us a new science, has established upon a firm basis a science of medicine and a science of surgery, and has added to the financial stores of the world accumulations of great magnitude. It was all done by slow work. The field was not a new one, for already investigators had made inroads therein, but no

one with anything like certainty and accuracy. For years it was Pasteur alone who was capable of investigating bacteriologically with anything like a certainty of successful issues. Bacteriological methods were too difficult to be handled by anything but a master. To-day it is true the methods have been so simplified that far less genius is required to handle them, and to-day the bacteriologist has multiplied in every direction. But at the time when Pasteur was the pioneer the methods were so difficult as to be beyond the reach of any except those of the greatest genius. Nor can we measure our debt to Pasteur by his own work. This, indeed, was great, but our debt to him must be also measured by the work of followers who were inspired by him. In France, in England, in Germany, in America, we find the study into this realm of the microscope inspired by the long, laborious and successful work of the French master. Even in the latest achievement, the use of antitoxine, we have the direct result of Pasteur's life. Where one leads others may follow. For a long time Pasteur stood alone, and it was only work that he had done that could be looked upon as demonstrated. Little by little, however, others came into the line of research, and when to-day Pasteur is taken from the field of activity there are many capable of carrying on his work. No man that France has created is so worthy of her pride. No man who has lived in history has done so much for humanity. No one who has lived will be remembered by posterity as having had such an influence upon the world in the way of discovering facts which advance the health and prosperity of mankind. But, perhaps, the proudest achievement he attained, viewed from the standpoint of a scientist, was earning the right to the claim that '*Pasteur never makes mistakes.*'

H. W. CONN.

WESLEYAN UNIVERSITY.

PASTEUR AS ILLUSTRATION OF MODERN
SCIENCE.

APART from the inspiring promises and hopes of high science, every one should realize clearly the direct practical value to be derived in the daily intercourse of each with nature, from a correct knowledge, of even the most elementary, of the laws of this world in which we are striving to live happily.

It is true that the advocates of science-teaching can adduce other, perhaps far nobler grounds, in pointing out the high and symmetrical development, which the study of science gives to the human intellect and the unfailing well-spring of pure pleasure which it affords.

But many of the older men now in power, having never had any accurate training in science, can scarcely appreciate such arguments, and if capable of being reached at all, it must be by proofs the most cogent of the unfailing utility of elementary science, and the stupendous wealth producing power of high science.

We cannot any longer afford to let children grow up ignorant of all that is going on around us in this beautiful world, without learning to use eyes and reasoning powers, because their parents may know nothing accurately of the laws of physical, but above all, of mental health.

Fundamental principles and their commoner applications must now be universally taught, if only to let every one realize how now our modern science stands ready to aid, to save, to satisfy, endangered or craving bodies or minds.

Nor is it only to the mature mind that the study of science is a pleasure. It has been well said that nothing is more beautifully characteristic of young children than the desire to know the why and wherefore of everything they see. This natural spirit of inquiry needs only proper direction and fostering care to give us great scientists,

men who, like Pasteur, confer uncounted millions of actual physical wealth on the country or state so fortunate as to be honored by their presence.

The great practical difficulty, however, in regard to giving science the place every one is beginning to see belongs to it, in elementary as well as advanced education, is that it requires for success, teachers of far higher order than those usually employed to drum into young heads the dry old school routine. No one can teach science who does not know it. And for a teacher to have the true informing spirit to vivify his book knowledge, it is found almost uniformly essential that he should have been in direct personal contact with some one of those great men whose joy it is to be able to advance the age in which they live, and lead on mankind to unexpected victories in the progressive conquest of the universe.

To get our brightest young people so to qualify themselves, it is needful they should understand the surpassing dignity of science and science teaching; that in fact, of late years, not only surprising discoveries are coming on in crowds, but that whole new sciences of world-remaking power are springing into existence around us. As one illustration from many, take what has been called bacteriology.

It is only a little more than 20 years ago that the publication of Pasteur's papers on alcoholic fermentation gave the first sound basis for the idea that fermentation was caused by a micro-organism.

It is now demonstrated that *all* fermentations of this class are due to the development of micro-organisms, and that bacteria are most important factors in nature, being the chief agents by which the complex organic constituents of plants and animals are brought back to simple forms capable of serving again as food for plants.

Following closely on Pasteur's early publications, and as a direct result of them, we

have the great revolution in surgery brought about by Sir Joseph Lister, which has enlarged the whole scope of the science, and is daily saving hundreds of lives.

Besides the vast increase in our knowledge of the mode of spread of infective disease, successful experiments have been carried on by Pasteur on the attenuation of virus and the conversion of virulent micro-organisms into useful vaccines.

And perhaps one could not choose a more readily understood illustration of the wealth conferred on his whole nation by a man of science than is furnished by a recapitulation of some of the things accomplished by Pasteur. Having discovered exactly what fermentation is, he was able, by a few simple directions, to almost entirely put an end to the spoiling of beer by secondary fermentation and the souring of wines by the transformation of alcohol into acid.

This sounds rather unimportant, but some idea of its commercial value may be obtained when it is remembered that there are about 45 departments of France that make wine, and there was a known loss yearly of wine to the extent of one million seven hundred thousand francs in four departments. Since Pasteur's method has been applied, there has been saved of this loss at least one million five hundred thousand francs annually. This is for four departments. As there are in France about 45 departments that make wine, you may approximately estimate the stupendous saving.

Again the farmers and stockmen of France were visited by a terrible and increasing cattle plague, the malignant pustule, or black quarter of cattle and sheep, which killed annually thousands of horses and oxen and hundreds of thousands of sheep. There seemed no hope for them. But Pasteur found by a series of researches not only that this disease was caused by a specific minute organism, but that he could save the ani-

mals from contagion by inoculating them with attenuated germs obtained by artificial cultivations made in special liquids.

The figures from the official statement indicating the ravages made by this disease in France alone for the years 1882 and 1883 are 2,196 horses, 62,107 oxen, 538,245 sheep.

When we learn that the average mortality was reduced by Pasteur's inoculations in the proportion of 10 to 1 for sheep, and 15 to 1 for oxen, cows and horses, some idea may be grasped of his vast and continuous gift of wealth to his country in actual solid meat—beef and mutton.

Again, another disease has reduced the silk-worm industry to a most deplorable condition. In three departments in the center of France, after the silk-worm disease had attacked the factories, the product yielded a value of less than one million five hundred thousand francs.

But Pasteur came to the rescue, discovered the micro-organism, conquered it, and since the regulations laid down by him have been applied, the average value per annum, calculated on five years, in those departments has risen to more than twenty-two million francs.

After such facts as that, who can wonder at those sentences from Huxley: "I weigh my words when I say that if the nation could purchase a potential Watt, or Davy, or Faraday, at the cost of a hundred thousand pounds down, he would be dirt cheap at the money. It is a mere commonplace and everyday piece of knowledge, that what these three men did has produced untold millions of wealth, in the narrowest economical sense of the word."

But let no one suppose that these men or any other of the immortal scientists would have been satisfied even by producing untold millions of wealth. They all had higher aims and made higher achievements.

From such men and from science comes

a progressive betterment of human character, the final, the most precious result of evolution on this earth.

GEORGE BRUCE HALSTED.

AUSTIN, TEXAS.

DETERMINATION OF THE CONSTANTS OF
THE DIURNAL NUTATION.

(1) In the *Annuaire de l'Observatoire Royal de Belgique* for 1894, I gave the following results deduced from Gylden's observations of the latitude of Pulkova:

Let κ = constant of annual aberration,

κ' = reduced constant of systematical aberration,

i. e., projected on the equator, which I derived from my terms of the second order which arise from the combination of annual and systematical aberrations.*

\bar{a} = parallax of Polaris;

ν = Peters's constant of nutation $9''.2235$;

n = the correction of this constant;

ν' = Peters's constant of the term $\cos 2 \odot$ $0''.555$;

n' = its correction;

ν = the constant of the diurnal nutation;

L = the longitude of the first meridian,

i. e., the meridian which passes through the axis of the moment of inertia A of the solid crust of the globe.

Applying my formula, M. Byl, astronomer adjunct at the Royal Observatory of Belgium, has found

$\bar{a} = 20''.408$. $\kappa' = 39''$. $\omega = 0''.0546$.

$n = 0''$. $.003$. $n' = -0''.0444$.

$\nu = 0''.0665$. $L = 12^{\text{h}} 0^{\text{m}}$ E. from Pulkova.

Illness has prevented M. Byl from coördinating his calculations, and I was compelled to make a new determination of both the last constants for the next volume of the *Annales de l'Observatoire Royal de Belgique*.

(2) My purpose was to make use of the excellent series of observations of the Polaris in \mathcal{R} made at Dorpat by F. W. Struve,

* *Catéchisme correct d'astronomie sphérique* (Memorie della Pontificia Accademia dei nuovi Lincei, Roma. Vol. IX.), and *Annuaire de l'Observatoire Royal de Belgique pour 1894*, p. 346.

a series which had led me to conclude that the Eulerian period of 305 days was too short.*

In order to eliminate the variations of latitude, I have only used half of the sum of \mathcal{R} observed at consecutive upper and lower transits: The laborious calculation of the whole series has given me unexpected results: $\nu = 0''.17$, twice or threefold too great; $L = 12^{\text{h}} 10^{\text{m}}$ E. from Pulkova, good result; $n' = + 0'.045$, which is in complete discordance with the value $n' = - 0''.0444$ deduced from Nyrén's observations, and moreover, theoretically inadmissible. In seeking the cause of these unlooked-for results, I found that an error of sign I had noted down some years ago and considered as a simple typographical error has been used by Peters in all his reductions of Struve's observations. In his formulæ (p. 13 of *Numerus Constans nutationes*) he wrote with +, instead of -, the terms of nutation in $2 \odot$, and calculated his reductions with this erroneous sign.

All my work had to be done over again, as will be the case for Peters's determination of the constant of nutation.

In order to eliminate this serious error I used Struve's residuals, corrected by increasing by $0''.2$ the Delambre's constant he had used for his reductions, and to avoid the other errors of reduction I have formed the differences between successive pairs of observations chosen so that the coefficients Σ_1 and Σ_2 were sufficiently different in both pairs.

(3) The diurnal nutation in \mathcal{R} is in the meridian

$$\Delta a = -tg \delta (\xi \Sigma_2 + \eta \Sigma_1),$$

where $\nu = \nu \sin (2L + a)$, $\eta = \nu \cos (2L + a)$; we may write

$$\Delta a = x \Sigma_2 + y \Sigma_1 = ax + by.$$

The principal terms I have used for the calculation of a (Σ_2) and b (Σ_1) are

* *Annuaire de l'Observatoire Royal de Belgique pour 1891*.

$$\alpha = -0.18 \sin \Omega + 0.39 \sin 2 \odot + 0.89 \sin 2 \zeta \\ + 0.18 \sin (2 \zeta - \Omega).$$

$$b = -1.155 - 0.134 \cos \Omega + 0.36 \cos 2 \odot \\ + 0.82 \cos 2 \zeta + 0.14 \cos (2 \zeta - \Omega).$$

writing, with Peters,

$\pm v$ = correction for the position (E or W) of the circle; w = correction of the mean \mathcal{R} of Polaris, and remembering that the correction of the terms in $2 \odot$ has been eliminated by taking the difference between two pairs of observations, we have only the equation of condition

$$a x + b y \pm v + w + n = 0;$$

the unity of the residual, n , is the second of time.

(4) By taking the differences between the equations formed for such a pair of upper and lower culminations, two by two, it is clear that we shall obtain the simpler equation

$$(a_2 - a_1) x_2 + (b_2 - b_1) y + n_2 - n_1 = 0,$$

which we write

$$a x + b y + n = 0.$$

The following table gives the values of p weights of the two equations used; a , b , n , n' , multiplied by 100; the point after a number signifies 0.5. n' is the new residual obtained after the substitution, in each equation, of the values found for x and y .

| | p . | a . | b . | n . | n' |
|---------------------|-------|-------|-------|-------|------|
| 1822. Nov. 5 and 12 | (1.4) | -182 | -10 | -87 | -88 |
| 1823. May 6 and 16 | (1.2) | -138 | +77 | 6 | -5 |
| “ 16 and 19 | (1.2) | -110 | -82 | 33 | 45 |
| “ 19 and 21 | (2.3) | -26 | +56 | -36 | -45 |
| “ 21 and 30 | (3) | -29 | 145 | 14 | 8 |
| May 30 & June 2 | (3.4) | -84 | 47 | -10 | 4 |
| Sept. 8 and 11 | (1.2) | -53 | 120 | 2 | -17 |
| Oct. 9 and 11 | (1.2) | 58 | -12 | 15 | 18 |
| “ 11 and 13 | (2.3) | 63 | -52 | -34 | -25 |
| “ 13 and 28 | (3) | -28 | -39 | -37 | -32 |
| “ 28 & Nov. 8 | (2.3) | -17 | 80 | 37 | 24 |
| Nov. 8 and 14 | (1) | 63 | 50 | -59 | -66 |
| “ 14 and 26 | (1.2) | -132 | -96 | 23 | 37 |
| “ 26 & Dec. 8 | (1.2) | -88 | -38 | -15 | -8 |
| 1824. Apr. 6 and 11 | (1) | -102 | -175 | -90 | -63 |
| “ 11 and 23 | (1.3) | 81 | 149 | +79 | +56 |
| “ 23 and May 1 | (2.3) | -76 | +58 | -30 | -40 |

| | | | | | |
|----------------------|-------|------|------|-----|-----|
| May 1 and 3 | (1.2) | 55 | -10 | 72 | 74 |
| “ 21 and 22 | (2.4) | -72 | -15 | -25 | -24 |
| “ 22 and 28 | (2.3) | -6 | -199 | -23 | -1 |
| “ 28 & June 2 | (1.3) | -96 | -146 | -15 | 10 |
| June 2 and 7 | (1) | -33 | -37 | 43 | 48 |
| “ 7 and 9 | (1) | -119 | 114 | 64 | 44 |
| “ 9 and 12 | (1.2) | 144 | 25 | -7 | -9 |
| “ 12 and 17 | (1.2) | -5 | -136 | 15 | 37 |
| “ 17 and 22 | (1.4) | -121 | 62 | -19 | -30 |
| Sept. 22 and 25 | (2) | -100 | 70 | -7 | -20 |
| “ 29 & Oct. 3 | (2) | +156 | -16 | -27 | -22 |
| Oct. 18 and 22 | (1.2) | -142 | 65 | 26 | 14 |
| Nov. 20 & Dec. 5 | (1.2) | 53 | 29 | -61 | 65 |
| Dec. 5 and 19 | (2) | 62 | 17 | -41 | 43 |
| 1825. Mar. 15 and 17 | (2.3) | -54 | -61 | -33 | 24 |
| “ 17 and 20 | (2.3) | -102 | 57 | 2 | -9 |
| “ 20 & April 1 | (2.3) | 45 | -38 | 51 | 58 |
| April 1 and 8 | (2) | 12 | -116 | 70 | 51 |
| May 1 and 7 | (1.3) | 147 | 44 | -82 | 87 |
| “ 7 and 10 | (1.3) | 3 | -52 | -18 | -10 |
| “ 10 and 18 | (1.4) | -125 | 84 | 2 | -13 |
| June 1 and 3 | (3) | -59 | -40 | 27 | +33 |
| Oct. 2 and 5 | (1.3) | -30 | -110 | -49 | -32 |
| “ 3 and 4 | (1.2) | 35 | -9 | 11 | +13 |
| “ 22 & Nov. 7 | (1.2) | -62 | -0 | 34 | +33 |

(5) From this system we have deduced the normal equations

$$3882.5 x + 142.6 y - 27.6 = 0 \\ 142.6 x + 3801.7 y + 613.9 = 0,$$

which gives

$$x = 0.013 \pm 0.0044 \\ y = 0.162 \pm 0.0049,$$

Where we deduce from

$$x = -v \operatorname{tg} \delta \sin (2L + \alpha) \\ y = -v \operatorname{tg} \delta \cos (2L + \alpha)$$

$$v = 0.0070 \pm 0.0019.$$

$$2L + \alpha = 357^\circ 20' \pm 46'.$$

$$2L = 342^\circ 52' \pm 46'.$$

$$L = 11^{\text{h}} 25^{\text{m}}.7 \text{ E. from Dorpat}$$

$$= 11^{\text{h}} 11^{\text{m}} \text{ E. from Pulkova.}$$

The agreement between the constants deduced from Gylden's observations of Polaris in Declination $\nu = 0.00665$, $L = 12^{\text{h}} 0^{\text{m}}$ E. from Pulkova, and from Struve's observations in \mathcal{R} , together with all the determinations I have made of these constants since 1888,* and with the smallness of the

* Annuaire de l'Observatoire Royal de Belgique, 1888-1894.

probable errors, is an irrefutable proof of the diurnal nutation.

The observations of Peters on the latitude of Pulkova had given me* $\nu = 0.''17$, $L = 11^h 58^m$ E. from Pulkova. But these observations are not nearly so precise as Gylden's and have given a constant much too great.

(6) In order to corroborate my own conviction, I tested the determination of these constants by means of a short series of observations, treated like the preceding of Struve. This series is from Preuss' observations (1838, May 18–June 29).

In this case again the equation will be

$$ax + by \pm v + w + n = 0.$$

The following table gives the values of p , a , b , n . For such a short series we could not introduce the correction of the term $\sin 2\odot$, and we can expect a much too great value for ν . Our criterion will also be the longitude L .

| 1838 | p | a | b | ± 1 | n (in sec. of arc) |
|----------------|-----|---------|-------|---------|----------------------|
| May 19 | 4 | 0.56 | -0.55 | +1 | - 3'.14 |
| 28 | 2 | -0.53 | -1.51 | -1 | - 5.94 |
| May 29, June 1 | 2 | -0.33 | -1.04 | -1 | -10.6 |
| June 7 | 4 | 0.79 | -2.34 | -1 | - 1.67 |
| 9 | 3 | -0.0167 | -2.64 | -1 | + 3.03 |
| 11 | 4 | -0.742 | -2.40 | -1 | - 7.14 |

$$\begin{aligned} \Delta \theta &= y \{ (\Sigma_1 \sin \epsilon'_1 - \epsilon_1 \sin R'_1) + 2.18 (\Sigma_2 \sin \epsilon'_2 - \epsilon_2 \sin R'_2) \} \\ &\quad + x \{ (\Sigma_1 \cos \epsilon'_1 - \epsilon_1 \cos R'_1) + 2.18 (\Sigma_2 \cos \epsilon'_2 - \epsilon_2 \sin R'_2) \} \\ \sin \theta \Delta \lambda &= x \{ (\Sigma_1 \sin \epsilon'_1 - \epsilon_1 \sin R'_1) + 2.18 (\Sigma_2 \sin \epsilon'_2 - \epsilon_2 \sin R'_2) \} \\ &\quad - y \{ (\Sigma_1 \cos \epsilon'_1 - \epsilon_1 \cos R'_1) + 2.18 (\Sigma_2 \cos \epsilon'_2 - \epsilon_2 \sin R'_2) \} \end{aligned}$$

in which the index 1 is referred to the Sun, 2 to the Moon. The notations are the following:

$$\Sigma = (1 + \epsilon_2) \sin (1 - \frac{1}{2} \epsilon_2) \Delta t, \quad \epsilon = (1 + S_2) \sin (1 - \frac{1}{2} \epsilon_1) \Delta t,$$

Δt being the interval between the two observations.

$$b_2 = \frac{2}{3} \epsilon_2 - \frac{C-A}{A}, \quad S_2 = \frac{2}{3} \epsilon_2 - \frac{C-A}{A} \cdot 1 \frac{C-A}{A} = 0.00328.$$

$$T_2 = a_2 + 2 d_2; \quad \tau_2 = a_2 - 2 d_2,$$

* Ibid., 1894.

† *Theory of the diurnal, annual and secular motions of the axis of the earth.* Brussels. 1884.

| | | | | | |
|---------|---|--------|-------|----|--------|
| June 13 | 4 | -0.713 | -1.19 | -1 | - 8.64 |
| 19 | 1 | 1.01 | -1.96 | +1 | -15.0 |
| 27 | 3 | -0.443 | -0.96 | -1 | - 4.92 |
| 29 | 4 | -0.193 | -0.70 | +1 | -0.113 |

(7) From this system we have deduced the normal equations

$$\begin{aligned} - 3.25x - 46.6y - 7v + 31w - 108.03 &= 0 \\ 5.60 + 26.9 + 31 - 7 + 79.55 & \\ 10.46 + 4.01 + 5.6 - 3.25 + 24.92 & \\ 4.01 + 88.0 + 26.9 - 46.58 + 82.22 & \end{aligned}$$

whence

$$x = 5''.6 \quad y = 15''.4 \quad v = -11''.3 \quad w = 20''.7$$

All these values are very great, which arises from the size of the residuals. It is to be noticed, however, that the signs of v , u , w are the same as those deduced by Peters from all the observations of Preuss.

From x and y we deduce $t\gamma$ ($2L + \alpha$), whence $L = 12^h 8^m$ E. from Dorpat, which agrees very well with all the preceding determinations.

(8) I will now give still another remarkable example of deductions, and one which shows the diurnal character of this nutation. For this case I have given the formulæ referred to the equator, which dispense with the calculation of the functions Σ_2 and Σ_1 . From these formulæ I have deduced the following expressions for the diurnal nutation in obliquity, $\Delta \theta$, and in longitude $\Delta \lambda$:

α_2 and d_2 denoting $\frac{\alpha_1}{n}$ and $\frac{d_1}{n}$, a_1 and d_1 the mean motion of the perturbing body (Sun or Moon) in \mathcal{R} and D , n the diurnal motion of the Earth.

$\zeta' = S - 2\tau$, $R' = R - 2\tau$, τ being the mean between the sidereal times of both observations, $S = A + 2D$. $R = A - 2D$.

$A = \mathcal{R}$, $D = \text{Decl. of the perturbing body, calculated for the time } \tau$.

$$x = \nu \sin 2L', y = \nu \cos 2L', L' = L + \tau,$$

whence $tg 2L' = \frac{x}{y}$; $\nu = \frac{x}{\sin 2L'}$; $L = L' - \tau$.

| Datum. | τ h m | Δt h m | $\Delta \alpha$ | $\Delta \delta$ | $by \Delta \theta$ | $by \Delta \lambda$ | S_1 | R_1 | S_2 | R_2 |
|---------------|---------------|-------------------|-----------------|-----------------|--------------------|---------------------|----------|----------|----------|-----------|
| 1879. June 17 | 17 25 | 4 53.5 | | | 0.4975 n | 0.4737 | 132° 39' | 39° 3' | 111° 31' | 11° 35.5' |
| " 20 | 17 45 | 4 9 | | | 9.8754 n | 0.0340 | 135 55.5 | 42 7 | 150 47 | 53 58.5 |
| " 21 | 18 33.5 | 2 31 | | | 9.9921 | 0.0590 n | 136 50 | 43 2 | 158 59 | 74 0 |
| " 22 | 19 49 | 0 53 | | | 9.6383 | 9.6798 n | 138 5 | 44 19.5 | 164 19.5 | 95 44 |
| " 25 | 17 22.5 | 4 52 | | | 9.5111 | 9.5828 n | 141 4 | 67 3 | 169 3 | 153 19.5 |
| Jul. 1 | 19 41 | 1 40.5 | | | 9.5488 | 9.8870 n | 146 42 | 54 18 | 199 44.5 | 303 15.5 |
| " 4 | 18 4 | 3 45 | | | 0.1130 | 0.3666 n | 149 16 | 57 45.5 | 255 9 | 339 28.5 |
| " 7 | 20 31 | 1 13 | | | 0.2992 | 0.3666 n | 151 35 | 61 47 | 325 46 | 348 41 |
| Aug. 9 | 20 8.5 | 4 51 | | | 9.8052 | 9.8693 n | 170 52 | 107 38.5 | 82 5 | 358 36 |
| " 17 | 20 20 | 5 28 | | | 0.3256 | 0.3920 n | 173 34 | 120 5 | 167 31 | 124 9.5 |
| " 18 | 21 17 | 7 26 | | | 0.1224 | 0.1884 | 173 50.5 | 121 43 | 168 51 | 149 48.5 |

The observations give Δa and $\Delta \delta$, differences between the residuals n_a and n_δ obtained by each observation; whence we deduce by means of the known formulæ of transformation $\Delta \theta$ and $\Delta \lambda$.

(9) The following table gives all the elements of the calculation, extracted from the "Annales de l'observatoire de Kiev (5 min. W. from Pulkova), Vol. I., Observations de la Polaris sime par Fabritius." All the calculations were kindly made by M. Niesten, astronomer at the Royal Observatory of Belgium.

Whence the following equations, where the numbers are expressed in logarithms:

| | | v | $2L'$ | L' | L |
|-------------|---------|-------|--------|--------|---------|
| | | | h m | h m | h m |
| 17 June | 1879. { | 0.122 | 135.7 | 4 30 | 11 5 |
| " | " { | 0.044 | 127.18 | 4 14.5 | 10 29.5 |
| 21 " | " { | 0.104 | 132.20 | 4 24.5 | 9 51 |
| 22 " | " { | 0.102 | 151.24 | 5 3 | 9 14 |
| 25 " | " { | 0.076 | 127.32 | 4 15 | 10 52.5 |
| 1 June-Oct. | " { | 0.063 | 154.18 | 5 8.5 | 9 27.5 |
| 4 " | " { | 0.119 | 201.00 | 6 42 | 12 38 |
| 7 " | " { | 0.095 | 166.16 | 5 32.5 | 9 1.5 |
| 9 Aug. | " { | 0.050 | 142.56 | 4 45.5 | 8 37 |
| 17 " | " { | 0.114 | 167.25 | 5 45 | 9 25 |
| 18 " | " { | 0.128 | 180.30 | 6 1 | 8 44 |
| | | Mean, | 0.091 | | 9 58.6 |

The agreement between these various determinations is truly most satisfactory, so much the more so as many of them (the 4th, 6th and 8th), are from observations whose interval does not reach two hours.

It is sufficient to establish, not the values of the constants (the number of observations is too small), but the existence of diurnal nutations.

(10) In conclusion, I believe astronomers

may at once introduce in their reductions my expressions of the diurnal nutation, employing the constants:

$$\nu = 0''.07, L_0 = 1^{\circ}.5 \text{ E. from Greenwich.}$$

My formulæ are, *in the meridian*:

$$\Delta a = -\eta \delta (\eta \Sigma_1 + \xi \Sigma_2).$$

$$\Delta \delta = -\xi \Sigma_1 + \eta \Sigma_2$$

$$\xi = \nu \sin (2L + a); \quad \eta = \nu \cos (2L + a);$$

$$L = L_0 + \lambda$$

λ denoting the longitude of the observatory, W. from Greenwich.

$$\Sigma_1 = -1.155 - 0.134 \cos \Omega + 0.36 \cos 2\Omega$$

$$+ 0.82 \cos 2\Omega + 0.14 \cos (2\Omega - \Omega) - 0.13 \cos (\Omega - \Gamma')$$

$$\Sigma_2 = -0.18 \sin \Omega + 0.39 \sin 2\Omega + 0.89 \sin 2(\Omega +$$

$$0.18 \sin (2\Omega - \Omega)$$

$$+ 0.07 \sin (3\Omega - \Gamma') + 0.07 \sin (\Omega - \Gamma'),$$

where the arguments are true longitudes.*

F. FOLLIE,

DIRECTEUR DE L'OBSERVATOIRE ROYAL DE BELGIQUE.

CURRENT NOTES ON PHYSIOGRAPHY (XVII).

THE LABRADOR PENINSULA.

THE last few years have added much to our knowledge of this inhospitable region. Besides the Bowdoin expedition to the Grand falls of the Hamilton river, Low and Eaton, of the Canadian Geological Survey, traversed the interior by several routes (London Geogr. Jour., June, 1895, 513-533, map) and Bell, of the same survey, gives an excellent summary of his own explorations and of all available material (Scot. Geogr. Mag., July, 1895, 335-361, map). Labrador is a moderately elevated plateau, averaging 1,800 feet above the sea, of Archaean rocks; hilly, interspersed with many lakes and swamps, and having a surface of bare rocks, alternating with numerous and large boulders and other glacial debris.

*The constant term of Σ indicates that each star position of every catalogue must be corrected with $\Delta a = \delta'' .081 \tan \delta \cos (2L + a)$, $\Delta \delta = -0'' .081 \sin (2L + a)$. The last form of correction has been detected empirically by Gould in his own catalogue of Cordoba, and has allowed me to reduce greatly the systematic differences noticed by Downing between the catalogues of Greenwich, the Cape and Melbourne. (See *Annuaire* for 1894, p. 348 and 372.)

Mountains rise along the northeast, north and northwest border, the loftiest being the first named, with summits reputed to be 8,000 or 9,000 feet high. These present steep sides and jagged crests, and are believed to have escaped the glaciation that ground so heavily over the rest of the region. The largest of the numerous lakes in the interior plateau—Mistassini—is a hundred miles long. Many lakes have two outlets. The rivers on the plateau do not flow in deep or well defined valleys, but are prone to spread over the country in straggling channels; branches turn off unexpectedly on either side and, after an independent course of from five to fifty miles, rejoin the main channel. Every river is broken throughout its whole course by falls and rapids at irregular but generally short intervals, thus necessitating many portages in canoe traveling. Canyons like that of Hamilton river, and fjords like that of the Saguenay, are explained by Bell as the sites of deep-weathered dykes, cleaned out by glacial action. Grand falls on the Hamilton occur where this river plunges down the side of the canyon, which continues for twenty-five miles to the northwest, although not occupied there by any considerable stream. Recently elevated beaches occur along the eastern coast, up to 500 feet above the sea. Excepting in the north, the plateau is generally forest covered, but the trees seldom reach two feet, and are generally less than one foot in diameter. Great loss is caused by forest fires. The population is very scanty; 18,000 total, or about one to thirty square miles; and most of these live near the St. Lawrence and Atlantic coasts. About a thousand schooners, many of which carry several families, go from Newfoundland to the Atlantic coast to fish in the summer.

TRANSVERSE VALLEYS IN THE SOUTHERN ALPS.

FÜTTERER concludes a careful study of the 'Durchbruchsthäler in den Süd-Alpen'

(Zeitschr. Gesell. f. Erdk., Berlin, xxx., 1895, 1-94), with the following reflections, here condensed: The most intimate knowledge of the geology of a river basin, including not only the composition of the strata but even reaching to the origin of their particles, is necessary to provide an interpretation of the origin and continual changes of a river system. Even in well-studied regions the results do not suffice to solve such problems, for unfortunately an interest in these 'geographical' questions is often absent among geologists. On the other hand, neither can the simple study of the actual condition of a river course explain the deeper problems of its geological development. As in the organic world, so here in the relations between mountain form and river courses, only from a knowledge of the processes of origin can we gain a true understanding of the world as it stands before our eyes (p. 92). This is sound physiographical doctrine. Fütterer discovers from the small remnants of ancient river deposits on the passes been the upper Tagliamento and the streams of the Carinthian Alps that these modern rivers are only feeble successors of a once much stronger river system that headed in the central Alps; and further that the Tagliamento, which exceeds both in drainage area and water volume the other rivers of the region, is only a *parvenu* among the Carinthian streams (91). The author notes (p. 78) a close agreement of his results with those obtained by Foerste in his thesis on the Drainage of the Bernese Jura (Proc. Boston Soc. Nat. Hist., 1892). Details are given concerning many streams, after which a general history of their development is presented (p. 76).

A SWISS LANDSLIDE IN THE GLACIAL PERIOD.

THE valley of the Linth is obstructed for about four miles above (south of) the village of Glarus by a mass of loose material

which Heim identifies as the product of an immense landslide or mountain fall (Der diluviale Bergsturz von Glärnisch-Guppen, Vierteljschr. Naturf. Gesell. Zurich, xl, 1895, 1-32). The scar left by the fall is traceable on the lofty slope about two miles to the west. Morainic material lies upon the slide, and hence it is regarded as of at least glacial antiquity. Glacial action, however, not only did not suffice to clean out the valley, it did not even smooth down the rolling surface of the slide, or scrape away the river deposits that were accumulated up-stream from the barrier. The Linth now trenches the slide about half a mile back from its front on the eastern side of the original valley, as if the impetus of the slide had raised its margin to an up-hill slope. The greatest thickness of the slide is 200 meters. Its original volume is estimated at $\frac{1}{2}$ km.³, or about eighty times that of the great landslide of Elm in 1881. The Linth has now carried away about $\frac{1}{2}$ km.³; 4,000 or 5,000 years being thought time enough for this work.

VALLEYS IN THE PLATEAU OF THE ARDENNES.

ARCTOWSKI describes this interesting region (Bull. Soc. géol. France, xxiii., 1895, 3-9) as the result of marine denudation of a vigorous ancient mountain system, the Cretaceous sea being regarded as the most active agent in accomplishing its reduction to baselevel. Following a miocene elevation of the region, streams began to sink their valleys beneath its even and gently sloping surface. The Hoyou, a branch of the Meuse from the north, and one of the most characteristic of the smaller streams of the Ardennes, exhibits several alternations between gentler and steeper slopes, although the points of increasing slope do not manifest any definite relation to the entrance of side branches or to the geological structure of the bed. Arctowski therefore concludes that the changes of slope indicate

upward movements of the region; the effect of the earliest movement having now been propagated nearly to the head of the stream, while the latest elevation has caused a deepening of the valley only near its mouth. (The lateral terraces that might be expected if this explanation were true are not mentioned.) The extremely meandering course of many deep valleys in the plateau is ascribed to lateral erosion on convex curves of originally irregular courses, and not to perpetuation of meanders originally developed on upland surface and somewhat increased during the incision of the present valleys.

THE RIVERS OF SPAIN.

THIS large subject is treated in a descriptive manner, with especial reference to the value of rivers for irrigation and navigation, by R. Torres-Campos (*Bol. Soc. geogr. Madrid*, xxxvii., 1895, 7-32, 81-140). The excessive aridity of many river basins and the dependence of agriculture on irrigation are the themes of many pages. In the basin of the Ebro, for example, irrigating canals create productive farms, sustaining a dense population; but away from the streams there is neither tree nor bush, and one may there travel 'leagues and leagues' without seeing the trace of human habitation. The dryness of this region has obliged many of the laboring classes to emigrate. Some go to South America, some to France; and the improved condition of the few who return stimulates the departure of others. On parts of the coast of Valencia the streams from the mountains have built out a sloping plain of fertile alluvium, where the construction of roads and canals has been so easy that the region is occupied by a prosperous and progressive population. No consideration is given by the author to the origin of the rivers or to the present stage of their development.

W. M. DAVIS.

HARVARD UNIVERSITY.

SCIENTIFIC NOTES AND NEWS.

FIELD WORK OF U. S. GEOLOGICAL SURVEY.

DIRECTOR WALCOTT, of the U. S. Geological Survey, has returned to Washington, after a two months' absence in the northern Rocky Mountain region, spent in field work. He was studying the Cambrian rocks and faunas of Montana and Idaho.

The field work of the season is drawing to a close. Nearly all the geologic parties have come in, though work is still going on on the Pacific coast, and, to a small extent, in the Interior or Mississippi basin. Work in the northern Rocky Mountain region and in Washington was brought to a stop early in October by severe storms. In this region Mr. Emmons and Mr. Willis were at work as well as the director. The special work in Alaska, an examination of the gold and coal resources, was advanced so far as conditions would permit, and Drs. Becker and Dall are now in Washington preparing their joint report on the subject. Since submitting to the Secretary of the Interior his report on the character of the lands involved in the McBride claim in Washington, Mr. W. Lindgren, who made the expert examination for the Government in that case, has been mapping the geology of the mining region of northern-central California.

Topographic work is still in progress in all quarters. The number of sheets surveyed is unusually large and the work is generally of excellent character. Surveys are, or have been, in progress in about twenty-five States and Territories. The Chief Topographer, Mr. Henry Gannett, made an inspection of the work, especially that in the West. The work going on in Indian Territory is of special interest because of the peculiar conditions governing it. Here, in connection with the regular topographic mapping, a subdivisional or parceling survey is being made in the interest of the General Land Office. This

work was much retarded in the summer months, partly by the illness of the men, due to the prevalence of malarial fever, and partly by other unforeseen obstacles; but the conditions have improved and the work is now advancing with gratifying rapidity. This work will go on all winter.

Director Walcott will shortly prepare a succinct report of the operations of the field season, for the information of the Secretary of the Interior, briefly reviewing the work in all its branches.

THE 'INSTITUT PASTEUR'.

The Paris correspondent of *The Lancet* gives in the issue of October 26 an interesting description of the Institut Pasteur, from which we quote the following facts:

The Institute is the property of a company, but having been recognized by the Government *d'utilité publique* it is under the control of the State (Home Office). The *Assemblée* is made up of founders; by it the Council is elected, the accounts passed, etc. The revenue is derived from the following sources: (a) the interest of 1,200,000 fr., balance of the sum of nearly 3,000,000 fr., publicly subscribed, about two-thirds of which was absorbed by the acquisition of the land upon which the Institute stands and by the building of the said Institute; (b) a subvention of between 20,000 fr. and 30,000 fr. made by the Agricultural Department for services rendered ('vaccinations' of animals against charbon, glands, etc.); (c) a subvention (sum not mentioned) of the Ministry of Public Instruction to provide for the salaries of such officials as belong formerly to the *École des Hautes Études*; (d) profits derived from the sale of vaccines supplied at a low rate to veterinary surgeons, these profits having been ceded to the Institute by M. Pasteur and by MM. Roux and Chamberland (the revenue from this source reaches about 20,000 fr. per annum); and (e) fees paid

by the bacteriological students of the Institute.

The anti-diphtheric department, directed by Dr. Roux under the dual control of the Council of the Institute and the Ministry of the Interior, is an *annexe* of the Institute but has a distinct budget. The headquarters of this department are at Garches (where Pasteur died), on a property ceded to Pasteur by the State. The serum is distributed gratis, according to the demands of the Ministry of the Interior, to the army and to the hospitals and *bureaux de bienfaisance* of France and her colonies. The expenses are met by the interest of the public subscription (collected by the *Figaro*) and by a sum voted annually by Parliament (this year it amounted to 80,000 fr.). The serum is supplied to the public under the provisions of the Pharmacy Law, a small bottle being procurable at every druggist's for 3 fr. Any profit accruing from the sale will be devoted to the improvement of the particular *service*. The work done at the Institute comprises inoculations and lectures delivered by Drs. Roux and Metchnikoff, whose pupils are divided into two categories—those who are simply listeners and those who come to acquire the technique of bacteriology. There are, moreover, laboratories provided for investigators engaged in original research, the results of whose work are chronicled in the '*Annales de l'Institut Pasteur*.' The teaching *personnel* is as follows: Biological chemistry, M. Duclaux, who is besides professor at the Faculty of Sciences, but who now gives his lectures at the Institute instead of at the Sorbonne, as was the case formerly. Rabies: Professor Grancher, with the collaboration of Drs. Charrin and Chantemesse. Sanitary bacteriology, 'vaccinations' and practical applications: M. Chamberland. Morphological bacteriology: Dr. Metchnikoff. Technical bacteriology: Dr. Roux. Finally, Professor Nocard, of the Alfort Ve-

terinary College, superintends a veterinary service attached to the Institute. The Institute, opened in 1888, will continue its activity under the same constitution as under its late chief.

THE PHENOMENA OF FRICTION.

M. RAFFARD has extracted from the technological publications of the *Société des Anciens Elèves des Écoles nationale d'Arts et Métiers*, August, 1895, a paper* in which he summarizes the earlier work of Amontons (1699), of Coulomb (1781) and of Morin, Krest and Haton de la Goupillière in our own times, and proceeds to the discussion of his own recent experiments, particularly on the friction of cords and belts on pulleys and cylinders about which they may be wrapped. As early as 1880 he had noted the fact that the friction of such flexible wrapping connections was very slight at low velocities rapidly increasing with acceleration of speed, and had presented the results of his work to the Society (Trans. 1880, p. 671). The experiments of Holman (Jour. Franklin Institute, Sept. 1885) confirm his own conclusions. Giving Holman's graphical illustration of the relation of friction of slipping belts to speeds, he makes the following final deductions:

1. In sliding friction the relative motion of the bodies is in line of the resultant of the applied forces.

2. With rolling friction the resistance remains substantially the same as when starting from rest, both in the plane of rotation and transversely to that plane, and a wheel will roll in its own plane, until the adherence is broken either by lateral or by circumferential stress, when it will at once take up a line of motion corresponding to the resultant of the acting forces.

3. The coefficient of friction of belts on

* *Considérations sur les Phénomènes du Frottement*, N. J. Raffard, Paris, 1895. Pamphlet monograph. Pp. 15, 4.

turned and polished pulleys is at starting and at low velocities but about one sixth its magnitude at high speeds of relative motion.

GENERAL.

A BIOGRAPHY of Huxley is being prepared by his son, Mr. Leonard Huxley. *Nature* states that Mr. Huxley will be greatly obliged if those who possess letters or other documents of interest will forward them to him at Charter House, Godalming. They will be carefully returned after having been copied.

DR. HERBERT H. FIELD, whose address at present is 67 Rue de Buffon, Paris, announces that arrangements have just been made with Engelmann, of Leipzig, for a 'Bibliographia Zoologica,' and with Fischer, of Jena, for a 'Bibliographia Anatomica.' The former will be sold in book form annually at \$3.75, while in the card form it will be issued at the rate of \$2.00 per thousand cards. Dr. Field announces that it is necessary to secure 75 subscriptions to the Bibliography, in book or card form, in the United States. This will be the most complete and systematic bibliography which has ever been issued, and deserves the prompt and generous support of zoologists in all parts of this country. Subscriptions should be addressed directly to Dr. Field.

The Indian Engineer, a journal which has been published for quite a number of years in Calcutta, has recently changed its name to *The Indian and Eastern Engineer*, and extended its scope accordingly. Its object is to make engineers in the East acquainted with the best methods, American, English and Continental, employed in the industrial arts. Publications and articles descriptive of the arts and industries will be gladly received by the editor for republication in his journal. The editor of this journal is C. W. Merton, 137 Canning's Street, Calcutta, India.

OLZEWSKI recently succeeded in producing a momentary liquefaction of hydrogen by allowing it to expand suddenly from 140 atmospheres' pressure, when cooled to about -210°C . with liquid air or oxygen boiling under a pressure of less than 20mm. Its boiling point under atmospheric pressure was found to be -243.5°C ., only 30° above absolute zero. In a letter to Ramsay (*Nature*, Oct. 3) he now announces that under the same conditions *helium* shows no sign of liquefaction. Its boiling point is therefore still lower than that of hydrogen, and it is the most volatile substance known. In view of the great difficulty in reaching still lower temperatures, it would seem that the present methods will have to be considerably improved before helium can be liquefied.

CASSEL & Co., London, and Macmillan & Co., New York, will publish shortly: 'Clerk Maxwell and Modern Physics' by R. T. Glazebrook. Other volumes of the Century Science Series are: 'Michael Faraday, his Life and Works,' by Sylvanus P. Thompson; 'Humphrey Davy,' by T. E. Thorpe; 'Pasteur, his Life and Work,' by M. Armand Ruffer; 'Charles Darwin and the Origin of Species,' by Edward B. Poulton; and 'Hermann von Helmholtz,' by A. W. Rücker.

MACMILLAN & Co. are about to issue a second edition of *Mental Development in the Child and the Race*, by Prof. J. Mark Baldwin. The only important alteration is the correction in the tables on page 51.

INASMUCH as New Jersey has now been covered by the topographical maps of the Survey, Mr. Henry Gannet has been enabled to prepare a dictionary of all the names on them and to give references to the particular sheets on which they occur. The dictionary facilitates very much the locating of obscure places, such as villages, brooks, hills, etc., and enables one to quickly acquire a map of any portion of the

State. The dictionary is published as Bulletin 18 of the U. S. Geological Survey.

MR. EDWARD WHEELER PARKER has extracted from the sixteenth annual report of the Director of the United States Geological Survey his paper on the Production of Coal in 1894. After a brief introduction, descriptive of our American coal fields, a review of the production and labor statistics follows. A coal-trade review by business centers appears next, and then an account of recent official tests of various coals by the Navy Department. The bulk of the paper is occupied by the review of the several coal-producing States in alphabetical order. A geographical outline of the productive fields comes first, followed by statistics alike of output, labor, expenses, accidents and similar facts. Although concise, the paper is thorough and maintains the high character that has been established by the volumes on Mineral Resources.

THE *Critic* states that an interesting collection of weapons, ornaments, etc., gathered in Africa by the young explorer E. J. Glave, is exhibited at the office of The Century Co., in whose service Mr. Glave met his death in the Dark Continent, last May.

It is stated that of 597 trees struck by lightning in the forest near Moscow 302 were white poplars; and farmers are advised to plant these trees as protectors against lightning.

D. JAMES E. GARRETSON, dean of the Philadelphia Dental College, and known for his scientific contributions on diseases of the mouth, died on October 27th, at the age of 67 years.

MR. ROBERT BROWN, a distinguished botanist and traveller, died in London on October 27th, at the age of 53. Dr. Brown travelled extensively in North America and North Africa, and made important scientific contributions to botany, geology and zoölogy.

PROF. WILLIAM ABBOT PIKE died from pneumonia at Minneapolis on October 13th. He was for some years professor of engineering in the Maine State College and later held the same position in the University of Minnesota.

BARON LARRAY, member of the French Institute and of the Academy of Medicine, and known for his contributions to military surgery, died on October 8th, at the age of 87.

THE Manchester Museum has obtained a grant of £400 from the taxes collected for free libraries, which amount to about £20,000.

THE German Hygienic Association has offered a prize of 12,000 Marks for a paper on the efficiency of electric heaters. The essays must be written in German and sent to Professor Konrad Hartmann, Charlottenburg, not later than July 1, 1896.

THE *Popular Science Monthly* opens its forty-eighth volume in November under the name *Appleton's Popular Science Monthly*, with typography and paper materially improved. The journal will hereafter be published in England by Kegan, Paul, Trench, Trübner & Co. The ten articles of the current number are all concerned with anthropology, using this word in a wide sense. Professor Brinton's president's address before the A. A. A. S. is given, and among the other papers of interest is an illustrated article by Mr. H. P. F. Marriott, entitled 'Primigential Skeletons, the Flood and the Glacial Period.'

SEVERE earthquake shocks were felt in the central States just after 5 o'clock on the morning of October 31st, affecting especially Ohio, Illinois and Indiana. On the following day, at 5:40 in the morning, violent shocks were felt at Rome. The convent of Santa Maria Maggiore was greatly damaged. A portion of the outer wall was overthrown and part of the ceiling has fallen. Four

palaces and the Bank of Italy were so shaken that they are rendered unsafe for occupancy.

A MUNICIPAL museum was opened at Alexandria on September 26th containing a collection of antiquities belonging to the Greek, Roman and early Coptic periods. The municipality and the Alexandria Archæological Society are making excavations in the city and neighborhood, but hitherto their researches have proved only negative.

THE daily papers state that the Board of Managers of St. Luke's Hospital, New York, at a recent meeting decided to erect on the new site of the hospital, at One Hundred and Eighteenth street and Morningside avenue, a large building to be devoted exclusively to researches in pathology. It is to be specially devoted to investigation of dangerous micro-organisms. The managers appointed a committee with full power to erect the building, and declared it their opinion that an endowment fund of \$200,000 should be obtained and set aside for the pathological department. The plans of the new building have already been drawn up and will be submitted to the Medical Board in a few days. The building as designed will be one of the finest and most complete in appointments of any similar structure in America.

D. APPLETON & Co. announce two new volumes in the International Scientific Series, *Greenland Icefields*, by Prof. G. Frederick Wright, and *Movement*, by E. J. Marey.

THE French Association for the Advancement of Science will hold its next meeting in Tunis in April, 1896. In 1897 it will meet in St. Etienne. M. Distère, marine engineer, has been elected president of the Association and Dr. Leon Teisserenc de Bort general secretary.

DR. W J MCGEE, of the Bureau of American Ethnology, has started to explore

the hitherto unknown portion of Sonora county, Mexico, and Tiburon Island, on the coast of Mexico, inhabited by the Seri Indians, noted for their treacherous blood-thirstiness.

ACCORDING to *Nature* the Catalogue of the Library of the Royal Geographical Society, compiled by Dr. H. R. Mill, and lately published, is a very full and valuable index to the literature of geography. The Catalogue contains the titles of all works in the possession of the Royal Geographical Society published up to the close of 1893. The entries (amounting to as many as 18,000) are arranged in four divisions. The first division, which runs into 521 of the 833 pages, is a general alphabetical author's catalogue; the second comprises collections of voyages and travels, arranged in alphabetical order under authors' names, and containing a brief analysis of the contents of each volume; in the third division, government, anonymous and other miscellaneous publications are arranged geographically; while the fourth consists of a list of transactions and periodical publications, arranged in a similar manner according to the place of publication. With such a comprehensive classification, it is easy to find the works of each author and to refer to the literature concerning different divisions of the earth. A valuable supplement to the Catalogue will be the subject index now being prepared and in which the principal contents of all the geographical books and periodicals belonging to the Society will be classified.

A MONUMENT to Duchenne by M. M. Desvergnés and Debrie will shortly be erected in the Salpêtrière. It is also proposed to erect a memorial to Duchenne in his native city of Boulogne.

It is said that Professor Wollny, of Munich, has made some experiments which prove the utility of angle-worms for agri-

cultural purposes. He raised peas, beans, potatoes and other vegetables in wooden boxes, some with and some without worms, and in each case the presence of worms led to an increase in the crop, varying from twenty-five per cent. in the peas to ninety-four per cent. in the rye.

THE Canadian Medical Association will hold its annual meeting for 1896 in Montreal under the presidency of Dr. James Thorburn.

THE total number of new students who have entered the twelve London medical schools is 581, as compared with 552 in 1894.

MR. C. H. COCHRANE states in *Lippincott's Magazine* that the National Rapid Transit Company is asking the United States Senate for privileges looking to the establishment of a line between New York and Washington, and specifying in the proposed bill that the schedule time shall not be less than one hundred miles an hour, which necessitates a speed of a hundred and twenty miles per hour to cover loss from stops. Further, the General Electric Company of New York is willing to guarantee motors, generators and other electric mechanism for such a road, warranting them to maintain a speed of one hundred and fifty miles an hour when delivering a hundred horse-power per motor with two motors per car.

The New York Evening Post states that the documents of the Arctic explorer Jackson, brought back from Franz Joseph Land by the *Windward*, have been opened in London. They record that the expedition landed on September 7, 1894, at Cape Flora, where log houses were erected and a tempestuous winter was spent. Jackson and two others started north March 10, 1895, with two ponies and two sledges. The temperature was sometimes 45 degrees below zero. The country generally was 2,500 feet above sea level and was covered with

ice sheets, interrupted along the coast by high basaltic cliffs. The journey revealed many inaccuracies in the charts. The farthest point reached was latitude 81 degrees 20 minutes north, where two boats were left for use later in the summer. Many specimens were taken, which show that the geological formation of the land is mainly basaltic. A second journey began in April and ended in the middle of May. It was attended with stormy weather, and frequently the temperature was 50 degrees below zero. Jackson considers horses the best means of reaching a high latitude up to the end of April.

THE *Times* states that a series of archaeological discoveries have been made at Monkswood, near Bath, where a reservoir is being constructed to supplement the water supply of the city. The latest discovery was unearthed on Thursday from a mass of peaty deposit. It is an iron hatchet with a handle formed of a human leg bone. Round the socket is a rough ferrule of lead. The metal head was kept firm by means of wooden plugs, traces of which were found clinging to the iron. This is the only relic of the iron age discovered, but *œolitic* flint hammer heads and an interesting collection of bronze weapons and articles of personal adornment have been brought to light. These discoveries have been inspected by Professor Boyd Dawkins and other paleontologists. The bones of extinct mammalia have also been met with. The discoveries are in the charge of Charles Gilby, city engineer of Bath.

UNIVERSITY AND EDUCATIONAL NEWS.

THE corner stone of the new dormitory buildings of the University of Pennsylvania was laid on November 5th, Judge Robert M. Willson, Provost Charles C. Harrison and Bishop O. W. Whitaker taking part in the ceremonies. The dormitories are due to the initiative of Vice-Provost George

Stuart Fullerton and are planned on an elaborate scale, it being estimated that \$1,000,000 will be required to complete the buildings. They will include a dining hall and a chapel in addition to forty-four houses, forming one continuous building. Each house will have a separate staircase and will accommodate twelve to fourteen students with bedrooms, sittingrooms and bathrooms. There will be two courts, one triangular and one rectangular, separated by cloisters. The sixteen houses forming the triangle are already in course of erection and will be ready for occupation at the opening of the next academic year.

THE Public Hall of the University of Virginia, and the Rotunda, which contained the library, were completely destroyed by fire on October 27th. The loss is estimated at from \$150,000 to \$250,000, with an insurance of \$25,000. Efforts are already being made to collect money to restore the buildings, as they were before their destruction, and had been planned by Jefferson. A large part of the books in the library were saved, but many valuable papers and rare books that can never be replaced were destroyed.

THE trustees of Cornell University have voted \$2800 to build a small working observatory for the College of Civil Engineering.

THE *Bulletin of the American Mathematical Society* announces the following appointments: Prof. Samuel L. Barton, recently of the Virginia Agricultural and Mechanical College, to be professor of mathematics in the University of the South, Seewanee, Tenn.; Dr. Alex. Macfarland, formerly professor of physics at the University of Texas, to be lecturer in Lehigh University; Dr. E. B. Van Vleck, formerly of the University of Wisconsin, to be associate professor of mathematics in Wesleyan University, and Prof. C. A. Waldo, of De Pauw Univer-

sity, to be professor of mathematics at Purdue University.

THE free lecture courses on literary, scientific and technical subjects established by the trustees of the Lowell Institute, under the supervision of the Massachusetts Institute of Technology, Boston, began on November 4th. Twenty courses are offered, each consisting of twelve lectures.

AT the annual meeting of the Chicago Alumni of Mt. Holyoke College, on October 24th, Dr. D. K. Pearson offered to give \$150,000 to the College, provided the alumni would raise an additional \$50,000.

THE Rev. H. E. Cushman has been appointed assistant professor in philosophy in Tufts College.

REV. DR. R. J. PEARCE has resigned from the chair of mathematics at Durham University to take effect next Christmas.

PROF. KÖNIG, of Göttingen, has been offered the chair of surgery at Berlin, vacated through the death of Professor Bardeleben.

THE *Naturwissenschaftliche Rundschau* states that Dr. Ernst Lecher has been appointed to a chair of physics in the University of Prague; Dr. W. Müller has been offered a professorship and the position of director of the Zoölogical Institute of the University of Greifswald; Dr. Beck, a geologist of Leipzig, has been appointed professor of geology in the *Bergacademie* of Freiberg i. S.; Dr. Günther Beck von Mannagetto, professor of botany at Vienna; Dr. Rothpletz has been promoted to an assistant professorship at Munich; and J. C. L. Wortman to a professorship in the experiment station for chemical agriculture in Geisenheim. Dr. Karl Claus, professor of zoölogy in Vienna, has been retired.

CORRESPONDENCE

EXPERIMENTAL PSYCHOLOGY IN AMERICA.

TO THE EDITOR OF SCIENCE: *The American Journal of Psychology* began a new series last

week with an 'editorial' introduction, in which some most extraordinary statements appear. As an official of Harvard University I cannot let one of these pass without public contradiction. The editorial says (on the top of page 4) that the "department of experimental psychology and laboratory" at Harvard was "founded under the influence" of some unspecified person mentioned in a list of President Hall's pupils. I, myself, 'founded' the instruction in experimental psychology at Harvard in 1874-5, or 1876, I forget which. For a long series of years the laboratory was in two rooms of the Scientific School building, which at last became choked with apparatus, so that a change was necessary. I then, in 1890, resolved on an altogether new departure, raised several thousand dollars, fitted up Dane Hall, and introduced laboratory exercises as a regular part of the undergraduate psychology-course. Dr. Herbert Nichols, then at Clark, was appointed, in 1891, assistant in this part of the work; and when Professor Münsterberg was made director of the laboratory, in 1892, and I went for a year to Europe, Dr. Nichols gave my undergraduate course. I owe him my heartiest thanks for his services and 'influence' in the graduate as well as in the undergraduate department at Harvard, but I imagine him to have been as much surprised as myself at the statement in the editorial from which I quote—a statement the more remarkable in that the chief editor of the *American Journal* studied experimental psychology himself at Harvard from 1877 to 1879.

WILLIAM JAMES.

PSYCHOLOGICAL LABORATORY,

HARVARD UNIVERSITY, October 19, 1895.

EDITOR OF SCIENCE—*Sir*: In his truly remarkable Preface to the projected new series, the editor of the *American Journal of Psychology* puts forth the claim that the Yale psychological laboratory, like the other more prominent Eastern laboratories, was founded 'under the influence' of his pupils and of Clark University. Inasmuch as Yale University has an institutional interest in the truthfulness of this surprising claim, and inasmuch as I have reason to suppose that my influence and not President

Hall's led to the founding of its laboratory, I wish publicly to contradict him. This cannot be more effectively done than by calling attention to the facts of history.

Sixteen years ago, while at Bowdoin College and before I even knew of the existence of President Hall, I began the detailed study of the relations between the nervous system and mental phenomena. On coming to Yale, two years later, I continued diligently the same line of study, in the laboratory and with the kind assistance of Dr. James K. Thatcher, then professor of physiology in the Yale Medical School. To this line I soon added much research in the field of experimental psychology.

For several years I worked to the extent of twenty-five or thirty hours a week on a course of lectures on these subjects, which were illustrated by a small collection of material purchased by money granted for that purpose. Finally, in 1887, my 'Elements of Physiological Psychology' appeared, and in 1891 an abridged and revised treatise under the title of 'Outlines of Physiological Psychology.' Those were indeed days of small things; but the work done was honest and thorough, and it was pioneer work. As to the 'influence' of my books on the entire development of modern psychological study, in the laboratory and outside of it, in this country and in England (where several editions of them have been sold and where they have been required in examinations for a degree in medicine) and further abroad, I leave the impartial historian to discourse.

Three years ago, since my own work—especially with graduate students—had outstripped my powers, an instructor in experimental psychology and a man who could supervise the putting in order of a laboratory was sought. Dr. E. W. Scripture, on my nomination, was given an appointment for that purpose. But so far even as the fitting-up of the laboratory came under his influence, it is not true that this emanates to any appreciable extent from President Hall or from his University. For Dr. Scripture, a graduate of the College of the City of New York, spent the three long semesters from 1888 onward in Leipzig, in Wundt's laboratory, and the two intervening summer semesters at Berlin and Zurich with Zeller, Paulsen,

Diels, Ebbinghaus, Avenarius and Forel. At the time of his appointment at Yale he had indeed been, for about a year and a half, at Clark as a fellow, reading somewhat miscellaneous and using the laboratory as he chose, but without any regular instruction or supervision. His training, his instruction, his methods, are wholly from the Leipzig laboratory, and not at all from Clark University. This is, in fact, the entire extent of the 'influence' exerted by the writer of this truly remarkable Preface over the founding and development of the Yale psychological laboratory.

I will only add that two of the names mentioned in President Hall's list are much more pupils of Yale than of Clark. They belong among the twenty-three or twenty-four professors of psychology and philosophy which Yale has sent forth during the last fourteen years. Their *alma mater* is proud of them all; but not less so, because she has imparted to them a distinctly different spirit and *morale* from that displayed in late years by the writer of this Preface.

GEORGE TRUMBULL LADD.

YALE UNIVERSITY.

EDITOR OF SCIENCE: According to an editorial statement in the *American Journal of Psychology* for September, the Laboratory for Psychology in the University of Toronto was founded 'under the influence' of pupils of Stanley Hall. This is false. The Toronto Laboratory was founded by myself, then professor there, with an appropriation gained by my exertions and influence with the educational authorities of Ontario. No pupil of Dr. Hall had any influence in the matter in any shape or form, for my early training was gained at Princeton, where Dr. Hall's influence was not large!

Moreover, the general claim made by Dr. Hall in the 'editorial' to the paternity of scientific psychology in this country is ambitious to an extraordinary degree. In Princeton alone a course in physiological psychology was given by McCosh, with practical work by Professors Scott and Osborn, as far back as 1883.

J. MARK BALDWIN.

PRINCETON UNIVERSITY.

It seems a pity that President Hall, who has accomplished so much for the advancement of

psychology in America, should claim in an editorial article in the last number of *The American Journal of Psychology* that he has accomplished nearly everything. The scientific and academic growth of psychology in America during the past fifteen years has been notable, but the cause must be sought chiefly in the progress of science as a whole and the sharper differentiation of psychology from the other sciences. Even those who have done the most are representatives of such a movement, not causes of it. In the article in question it is stated that "under the influence of these men [those who received their training under President Hall] departments of experimental psychology and laboratories were founded at Harvard, Yale, Philadelphia, Columbia, Toronto, Wisconsin and many other higher institutions of learning." Professor James introduced experimental psychology at Harvard University, Professor Ladd at Yale University and Professor Baldwin at the University of Toronto, and their names do not appear on President Hall's list of former students. I began the work at the University of Pennsylvania with the coöperation of Professor Fullerton (where it is continued by one of our former students, Professor Witmer), and at Columbia College with the coöperation of Professor Butler. I am glad to have had the privilege of studying for four months under Dr. Hall at Johns Hopkins University, but I had previously studied for two years under Lotze and Wundt and held an appointment at Johns Hopkins University for some months before Dr. Hall was called as lecturer to that University. The other men mentioned first on President Hall's list—Professors Dewey, Jastrow (who began the work at the only remaining university mentioned) and Donaldson—were also members of Johns Hopkins University before Dr. Hall.

In the same editorial article it is stated that *The American Journal of Psychology* wishes to publish especially 'the results of experimental investigations in psycho-physic laboratories,' an 'Archiv function not yet represented by any serial publication in this field in English.' It is, however, easy to verify the fact that during the past two years *The Psychological Review* has published some forty-two experimental investi-

gations in psychology whereas *The American Journal* has published but twenty-seven.

J. MCKEEN CATTELL.

COLUMBIA COLLEGE.

THE RADIOLARIAN EARTHS OF CUBA.

TO THE EDITOR OF SCIENCE: The occurrence of Radiolarian earths in the land structure of the West Indian region has been of special interest to geologists, owing to the fact that they probably represent profound organic sediments of the deeper floor of the sea. The discovery of these earths in Barbados and Trinidad had excited wide interest, but little light had been obtained upon the important question of their geologic age.

In my recent papers* on the geology of the Island of Cuba, I have briefly described the geology of some interesting beds of siliceous earths which I collected from a locality in the suburbs of the town of Baracoa, and personally determined with the microscope to be composed of radiolarian remains. Through the determinations by Dr. Dall of fossils collected by me from the overlying strata, I was enabled to point out the important fact that they occurred immediately below strata containing fossils of undoubted Miocene age, and published a figure illustrating their geologic relations.

I was not aware at the time of making this publication that the existence of radiolarian beds in Cuba, much less at this particular locality, was known, as they are not mentioned in Professor Crosby's paper,† the only one previous to mine based on personal studies of the region.

In an article on the geology of the Barbados (to which Mr. J. W. Spencer has called my attention) by Mr. A. J. Jukes-Browne, published in the Quarterly Journal of the Geological Society of London for May 2, 1892, p. 221, the following interesting paragraph occurs:

"Cuba.—When this paper was read, Mr. J. W. Gregory was able to announce, from the examination of rocks he had obtained from Baracoa in Cuba, that radiolarian earths existed in that island; he finds them to be similar in structure

*American Journal of Science, September, 1894. Notes on the Geology of the Island of Cuba. Based upon a reconnaissance made for Alexander Agassiz, Cambridge, Mass.

†On the Elevated Coral Reefs of Cuba. Proc. Boston Society of Natural History, Vol. XXII., pp. 124-129.

and mode of occurrence, and also in their calcareo-siliceous varieties, to those of Barbados."

This previous publication clearly entitles Mr. Gregory to the original announcement of the radiolarian earths in Cuba, and had I known of its existence he should have received credit therefor in my papers, and my work has only resulted in the approximate determination of their age and mode of occurrence. The nature of Mr. Gregory's discovery is more fully explained, however, in a recent paper* in which he clearly sets forth the fact that he found these rocks, not in Cuba, but in Boston, in the collection made by Prof. W. C. Crosby in the Museum of Natural History, and refers to my preliminary paper for the facts concerning their occurrence and age. In this paper he also presents an interesting paleontologic study of this material showing the presence of 17 families, 25 genera and 33 species.

These are the facts concerning the knowledge of the radiolarian beds of Cuba: The material was first collected by Professor Crosby; their radiolarian nature determined from Professor Crosby's collections in Boston by Mr. Gregory; their geological occurrence and age described by the writer from studies on the ground, and their specific paleontology determined by Mr. Gregory.

On page 311 of Vol. 51 of the Quarterly Journal of the Geological Society of London, dated August, 1895, as a portion of the discussion following the delivery of Mr. J. W. Gregory's article on the Paleontology and Physical Geology of the West Indies, Mr. A. J. Jukes-Browne is quoted as follows:

"In view of these facts, we are quite prepared to accept Mr. Gregory's conclusion that the Oceanic Series is of Miocene age, the more so as Mr. Spencer has come to the same conclusion with respect to the Radiolarian Earths of Cuba, after a personal study of the geology of that island."

Inasmuch as Mr. Spencer makes no claim of having ever visited eastern Cuba, and has only seen the material from Baracoa which the writer collected, the above paragraph is liable to convey an erroneous impression concerning

* Paleontology and Physical Geology of the West Indies. Quarterly Journal of the Geological Society of London, August, 1893, pp. 293-95.

the discovery of the age and existence of these important beds.

ROBT. T. HILL.

WASHINGTON, D. C., October 16, 1895.

ERECT VISION AND SINGLE VISION.

PROF. CATTELL'S criticism of Prof. Brooks (SCIENCE for October 11, p. 487) in the matter of the inverted retinal image is undoubtedly just, but his reply has not made things any clearer. There is nothing specially inconceivable nor specially inexplicable about erect vision with inverted retinal image. It can be explained, too, without 'standing the soul on its head.' This may be a metaphysical but surely not a scientific explanation. In science what we mean by an explanation is a reducing of the phenomena in question to a law, which includes many other phenomena and especially the most common and familiar phenomena. Now, the seeing things in their natural or real position by means of inverted retinal images is a necessary result of the *law of direction*, and this law is the most familiar fact of common sensation. Let me explain:

Suppose I was standing on the plains of Arizona, captive, bound and blindfolded, surrounded by Apaches and a target for their arrows. I think I could tell with reasonable certainty the general direction of the Apache who shot any particular arrow. I would know it by the part struck and especially by the direction of the push of the arrow. I would refer the cause back along the line of the push to the proper place. There is nothing especially inconceivable in this. Now, suppose I look at the horizon. A star (I take this because it is a point) sends its ray into my eye through the optic center or nodal point, and it strikes a certain rod or cone on the lower half of the retinal concave. Is it anything specially strange that the impression—the punch—should be referred back along the line of the punch (ray line) to its proper place in space and, therefore, that I should see the star *above* the horizon? Now, objects are made up entirely of such stars—*i. e.*, radiant points—each sending its ray straight to the retinal concave, all crossing one another at the nodal point and therefore making an inverted image. But *each focal impression* (focal point) of the image is referred back along its own

ray line to its own place; and thus the external image is *reverted* in the act of external reference, and reconstructed in space in its true position as the sign and facsimile of the object that made it.

These facts will perhaps be made still clearer by the following diagram in which *r*, *r*, and *sp*, *sp*, represent the retinal and spatial concaves.

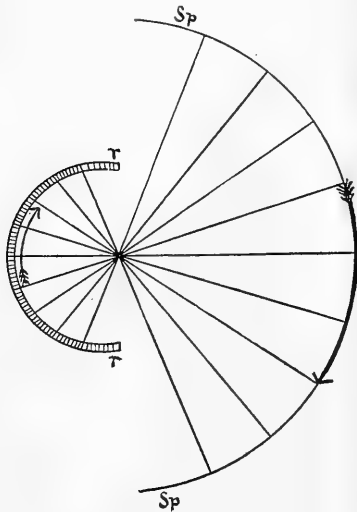

Every point, every rod and cone of the retina, has its fixed correspondents in space, and these correspondents exchange with one another by impression and external reference. The arrow and its retinal image are introduced to render the subject, if possible, still clearer. Although, indeed, I thought I had already made it sufficiently clear in my little book 'Sight,' pp. 83-89.

It is seen, then, that there are two fundamental laws underlying monocular vision: First, the law of external projection of retinal impressions into space. Second, the law of direction, *i. e.*, the mathematically definite direction of this projection. These two laws explain every phenomenon of monocular vision except *color perception*.

So again the apparent anomaly in Binocular vision of single vision with two retinal images

is, it seems to me, easily explained so far as sense perception is explicable by science at all. Those who observe closely their visual phenomena know perfectly that except under well known conditions we do see two objects or rather two external images of every object, and we know perfectly well which corresponds to, or is produced by, each retinal image. We see objects single only when these two external images of the same objects are placed one on the other and made to coincide. This takes place when the two retinal images of the same object fall on what are called corresponding points of the two retinae; because then, by the law of direction already explained, they are thrown to the same place in space and their external corresponding images coincide. Anyone accustomed to binocular experiments can at will separate these images and then bring them closer and closer, observing them the while, until they coalesce and the object is seen single. Is not this a sufficient explanation?

JOSEPH LE CONTE.

BERKELEY, CAL., October 17, 1895.

SCIENTIFIC LITERATURE.

A Text-book of Mechanics and Hydrostatics. By HERBERT HANCOCK, M. A., F. R. A. S., F. R. Met. Soc. New York, D. Van Nostrand Co. 1894. Pp. viii+409.

It goes without saying that the task of preparing a good elementary book on mechanics is now far easier than at any previous epoch in the history of the science. The clarification in fundamental ideas and the fixation of terminology which have come about during the past thirty years would seem to make it difficult for an author to depart very widely from sound definitions and logical development. It is somewhat surprising, therefore, to find a book whose author acknowledges his indebtedness to Maxwell, Thomson and Tait, and Clifford, marred by the very confusion of ideas which those eminent teachers have done so much to banish from mechanics.

Our suspicion of the author's fitness for his work is raised in the first paragraph of his preface, wherein he gravely affirms that "past experience leads me to conclude that no complete knowledge of mechanics can be got without some knowledge (however elementary) of

such subjects as plane trigonometry, variation and mensuration, etc., and with this in view I have premised the book by a simple statement of the methods of measuring angles, and the geometrical meanings of sine, cosine, etc., of an angle with simple explanation of the other operations." This might suffice to indicate the nature of the book, but it seems only fair to the public to give a few more specimens of the author's ideas. Naturally, we look to his chapters entitled 'Inertia and the Laws of Motion' and 'Energy and Work.'

In the former chapter, p. 83, we read, "From a large number of experiments we conclude that matter is incapable of changing its own state. This inert or passive condition is called the inertia of matter, and the law which regulates it is called the law of inertia." On p. 86, in reference to Maxwell's statement that "the change in momentum of a body is numerically equal to the impulse which produces it, and is in the same direction," the author remarks that "this law is sometimes called the law of impulse. We must be careful to distinguish between an impulse and impulsive force." Notwithstanding this caution, he says a few lines further on, "An impulse is a force which in a finite time produces a definite change of momentum." In the chapter on work and energy, p. 223, we are told "that there are many forms of energy, such as heat, light, chemical action, electricity, magnetism, etc. On this account the term mechanical energy is sometimes used to denote kinetic and potential energy." On p. 224, in explanation of a foot-poundal he tells us "this is sometimes called the absolute or kinetic unit of force. This unit," he adds, "was given by Newton, and it is probably the most accurate."

These illustrations, which might be easily multiplied to a wearisome extent, may serve to show the utterly chaotic character of the work in its treatment of fundamental principles. The author demonstrates clearly that if he has read the works of Maxwell, Thomson and Tait, etc., at all, he has read them to no purpose.

Mechanics (Dynamics). An Elementary Text-book, Theoretical and Practical, for Colleges and Schools. By R. T. GLAZEBROOK, M. A., F. R. S. Cambridge, at the University Press,

New York, [Macmillan & Co. 1895. Pp. xii.+256.

This little book on dynamics is one of the 'Physical Series of the Cambridge Natural Science Manuals.' It is the outgrowth of the author's experience in giving a practical course of lectures and laboratory work in mechanics to students of medicine. The result is one of the best elementary books we have seen—one well worth reading, in fact, by those who have passed beyond the elements of the science. "Mechanics" the author says, in his preface, "is too often taught as a branch of pure mathematics. If the student can be led up to see in its fundamental principles a development of the consequences of measurements he has made himself, his interest in his work is at once aroused, he is taught to think about the physical meaning of the various steps he takes and not merely to employ certain rules and formulæ in order to solve a problem." This gives the key to the plan of the book, and so well is the plan executed that even the dullest reader cannot fail to get instruction if he comes to the subject without erroneous preconceptions.

The book is divided into eleven chapters, which are characterized throughout by clearness and precision of statement and aptness of illustration. The first chapter deals with units and methods of measurement and with the terms used in mechanics. Chapters II and III are devoted to kinematics, the first to velocity and the second to acceleration. Chapters IV and V treat of momentum and the time rate of change of momentum respectively. The term *force*, concerning which there is commonly enough obscurity even with mechanicians, and a sort of abysmal profundity with those philosophers who are not naturalists, appears in Chapter V as the name for the rate of change of momentum.

These first five chapters furnish what the author considers a sufficient inductive foundation for the science. Thenceforth he proceeds by deduction chiefly. Thus, at the close of the fifth chapter he says: "We are now about to make a fresh start and consider Dynamics as an abstract science based on certain laws or axioms which were first clearly enunciated by Newton and are called Newton's Laws of Motion. We

shall endeavor in the next chapter to explain these laws and to show how they may be illustrated by the simple cases of motion already discussed; we then go on to assume them as true always and to deduce their consequences in other cases." By way of proper caution he adds, however, that "We shall not now discuss the question whether these fundamental principles were stated in their best form by Newton. Our present object is to give a consistent account of the Science of Mechanics as it has been developed from Newton's laws."

The following chapters VI-VIII are devoted to the consideration of Newton's laws of motion and the consequences deducible therefrom. The presentation of these matters is admirable and must take rank with that given in the best works hitherto published. Indeed, though the book professes to be elementary only, its exposition of these matters appears to be as luminous and complete as can be given without the aid of the calculus.

The last three chapters deal with curvilinear motion of a particle under gravity, collision of masses, and motion of a particle in a circle respectively. The book has many well chosen illustrative examples, whose answers are given in most, though, properly, not in all cases. There are a few samples of examination questions given, and the book terminates with a good index.

The faults of the work, if any may be fairly urged against it, are faults of omission rather than of commission. The only one which seems worthy of mention is the absence of an explanation and a use of the theory of the dimensions of the units which figure in mechanical quantities. Nothing, we believe, helps more to fix ideas with regard to the terms force, momentum, energy, etc., in mechanics than a knowledge of that theory, while its application is of great aid to the student in detecting and in correcting his blunders. An application of this theory, for example, will immediately detect the misprint in the formula on p. 187 of the book; though it is but just to add that this is the only misprint which that theory has disclosed in our reading of the book. We may express the hope that future editions of this capital work will be improved by the addition of an appen-

dix explaining the doctrine of units and dimensions of units in mechanical quantities and indicating the great utility of the doctrine to students and investigators.

R. S. WOODWARD.

Fourteenth Annual Report of the United States Geological Survey to the Secretary of the Interior, 1892-93. By J. W. POWELL, Director. Part I. Report of the Director. Part II. Geology—accompanying papers (Vignette). Washington, Government Printing Office. 1893. 8°, 2v.

Volume I., of 321 pages, is taken up by the administrative reports of heads of divisions and by other executive matters. The only general interest that it possesses lies in the fact that it sets forth the plans and policies of the Director and of the above officials. The second volume contains a valuable series of accompanying papers, viz:

1. Potable Waters of the Eastern United States, W J McGee, pp. 5-47.
2. Natural Mineral Waters of the United States, A. C. Peale, pp. 53-88.
3. Results of Stream Measurements, F. H. Newell, pp. 95-155.
4. The Laccolitic Mountain Groups of Colorado, Utah and Arizona, Whitman Cross, pp. 165-241.
5. The Gold-Silver Veins of Ophir, California, Waldemar Lindgren, pp. 249-284.
6. Geology of the Catoctin Belt, Arthur Keith, pp. 293-395.
7. Tertiary Revolution in the Topography of the Pacific Coast, J. S. Diller, pp. 403-434.
8. The Rocks of the Sierra Nevada, H. W. Turner, pp. 441-495.
9. Pre-Cambrian Igneous Rocks of the Unkar Terrane, Grand Canyon of the Colorado, Arizona, Charles D. Walcott, with notes on the Petrographic Character of the Lavas, by Joseph Paxson Iddings, pp. 503-525.
10. On the Structure of the Ridge between the Taconic and Green Mountain Ranges in Vermont, T. Nelson Dale, pp. 531-549.
11. On the Structure of Monument Mountain in Great Barrington, Mass., T. Nelson Dale, pp. 557-565.
12. The Potomac and Roaring Creek Coal

Fields in West Virginia, Joseph D. Weeks, pp. 573-590.

The first paper has popular interest but no geological importance. The second is an excellent summary of the country's mineral springs and will be often serviceable for reference. A list of the leading ones by States is included. The third paper has valuable data on the amount of flow in Western rivers, and on the Potomac, Connecticut and Savannah in the East. It will aid in the advancement of irrigation in the West, and our general hypsometric knowledge. The fourth paper is a most important contribution to the geology and petrography of the area discussed. It shows the great part played by laccolites in some of the best known Colorado mountains and the close parallelism that exists among them all in the character of the rocks. In the fifth paper Mr. Lindgren ably discusses the interesting gold-quartz veins of the Ophir district, Placer county, and draws some well based conclusions as to their method of origin. In the sixth paper Mr. Keith brings out a vast amount of new and important knowledge about the metamorphic and paleozoic belt that passes from Pennsylvania south through Hagerstown and Harper's Ferry, Md., and across West Virginia and Virginia to the Rappahannock River. Besides describing the local structural geology, and its development the paper includes an important contribution to the dynamic metamorphism of pre-Cambrian igneous rocks, both plutonic and volcanic. In the seventh paper Mr. Diller takes up the Tertiary changes in that most interesting problem, the recent geological history of the Pacific coast. The ancient base levels are traced and many important conclusions are deduced, which have a close connection with the auriferous gravels. Mr. Turner's paper (the eighth) presents an admirable review of the geology of the Sierras and adds greatly to our knowledge of their petrography. In the first part of the ninth paper Mr. Walcott describes the relations of the pre-Cambrian lava sheets to the other Algonkian terranes of the Grand Canyon, and gives detailed sections and views. Prof. Iddings identifies them as surface or submarine flows of basalt. In the tenth and eleventh papers Prof. Dale extends the area covered by his previously pub-

lished work in the metamorphic belt of the New York and New England border and especially in the latter, clears up the geology of a mountain famous alike for its geology and lovely scenery. Both papers are also important contributions to our knowledge of the mineralogical changes involved in the passage of sediments into schists and marbles. In the last paper Mr. Weeks describes, under the name of the Potomac basin, the important coal field that extends from Wellersburg, Pa., across Maryland into West Virginia, and that embraces the Cumberland or George's Creek coal of Maryland, and the Elk Garden and Upper Potomac coals of West Virginia. Analyses, sections and statistics are given.

The Production of Tin in Various Parts of the World. By CHARLES M. ROLKER. Advance excerpt from the Sixteenth Annual Report of the Director of the U. S. Geological Survey. 1894-1895. Part III. Mineral Resources of the United States. Calendar Year. 1894. Pp. 1-88.

It would appear from the above reference that the forthcoming annual reports of the Director of the Survey are to have a regular department devoted to Mineral Resources. This is to be warmly commended, both because it affords material that is of value to the general public, which is after all the Survey's real constituency, and because it caters to the scientific public as well. Many friends of the Survey have viewed with regret in recent years the small prominence that this portion of its work has received, and have felt that it was a mistaken policy.

Mr. Rolker gives an admirable and concise review of tin ores, their geology, statistics and the expense of production the world over. The report covers much the same ground in many respects as that treated by Professor Ed. Reyer in his 'Zinn, eine geologisch-montanistisch-historische Monografie,' that appeared in Berlin in 1881, but Mr. Rolker brings the subject down to date, omits many theoretical discussions and makes especially prominent those points that are of importance in their practical relations. The geology of cassiterite is curiously uniform, wherever the mineral is found. Veins in or

near granite or gravels yielded by them are its sources, whether it be in Cornwall, the Zinnwald, the Malay peninsula or Australia. The large part played by tin in the bronze implements of the ancients and even in prehistoric commerce give it peculiar claims to interest. Enormous attention has been devoted to tin mines in this country of late years, so much that the metal has even been a political factor, loudly heralded in recent campaigns. All our enterprises have as yet been without success, and some are instructive examples of extravagant folly. Mr. Rolker's dispassionate and truthful descriptions are timely and much to be commended.

J. F. KEMP.

The Natural History of Plants, their Forms, Growth, Reproduction and Distribution, from the German of Anton Kerner von Marilaun. By F. W. OLIVER, with the assistance of MARIAN BUSK and MARY F. EWART. With about 1,000 original woodcut illustrations and sixteen plates in colors. New York, Henry Holt & Co. 1895. 2 vols., large 8vo.

This is a most interesting and readable book. It is written in a clear and popular style; few technical terms are used, except where necessary for the sake of accuracy, and the illustrations are fine and full of interest. The whole plan of the work is to treat plants as living things and to find a biological significance for all the parts of which a plant is formed. Here will be found answered many of what may be called the practical questions about plants; such as why certain species grow in peculiar places, how they are adapted to the conditions which surround them, how they get their food, of what this food consists, how it is conducted and formed into organic matter, and the structures and forms resulting. As the author says, "For us no fact is without significance. Our curiosity extends to the shape, size and direction of the roots, to the configuration, venation and insertion of the leaves; to the structure and color of the flowers, and to the form of the fruit and seeds; and we assume that even each thorn, prickle or hair has a definite function to fulfil." The author claims the advantageous aid of imagination in his scientific researches and says

that "the more imagination an investigator has the more keenly is he goaded to discovery by this craving for an explanation of things and for a solution of the mute riddle which is presented to us by the forms of plants." It is probably due to this feature of the work that it is so readable, and yet its scientific facts do not suffer on this account. The first four chapters are devoted to the living principle in plants. Protoplasts are considered as the seat of life; the discovery of the cell and of protoplasm is recounted with illustrations of both; the movements of protoplasts are illustrated from the swarm spores of seaweeds, and the mosses and ferns; the movements of Volvocineæ, Diatomaceæ and Bacteria are described; the continuity of protoplasm through the cell walls and its relation to vital force and sensation are explained.

Under the heading of the Absorption of Nutriments, inorganic and organic foods are treated, the absorption of water and the character of soils, as well as the symbiotic relations of plants.

One of the most interesting chapters discusses the relations of the position of foliage leaves to that of absorbent roots, proving that the leaves conduct the rain to the point on the ground where the roots of the plant can get it; the peripheral increase of the leaves keeping pace with that of the roots. Most interesting diagrams are given of the position of leaves to facilitate this irrigation. In treating of Saprophytes illustrations are drawn of those in water, on the bark of trees and on rocks. Examples are cited from the simplest as well as the most highly organized plants, and many suggestions are given as to the habitats of plants.

The Absorption of Nutriments by parasitic plants is described at length and illustrated by numerous strange and unfamiliar examples. Carnivorous plants also receive ample attention and are illustrated by numerous cuts and a colored plate.

Under the heading of the Conduction of Foods, the author treats of the regulation of transpiration and the means by which leaves are protected from excessive dryness in exposed localities. The diversity in the structure of leaves is almost marvelous, and the figures given are of great variety and interest. In this

connection special adaptation to divers habitats brings about great differences in plants, and we find those of high altitudes and dry sunny locations differing widely from those of moist low places. Many of the problems of distribution and of special floras are touched upon in this connection. The special functions of the green leaves in the formation of organic food from the absorbed inorganic food; the transport of substances in living plants and the propelling forces in the conversion and distribution of materials constitute an interesting but a much more technical group of facts, leading naturally to the treatment of growth and ultimate structure of plants, till we reach the completed structures, passing by progressive stages in complexity from unicellular organisms to plant bodies and the forms of their roots, stems and leaves.

The remainder of the work is promised soon and will be looked for with much interest. The translators deserve a great deal of credit for the clearness of the style, the beauty of the text and the fine character of the illustrations, which are taken from the original plates, by permission of the author.

A traverse le Caucase. ÉMILE LEVIER. Neuchâtel, Attinger Frères. 1894.

As the rest of the title indicates, these are the notes and impressions of a botanist, illustrated by numerous photographs taken by one of the party, Mr. Stephen Sommier, supplemented by others from the collection of Vittorio Sella, whose Alpine and Caucasian views are famous. The illustrations add great interest to the work, giving, as they do, views of the people, their towns and buildings, and the wild, picturesque country in which they live. The journal also is full of word pictures, and recounts in a lively and interesting manner the experiences of the party, the details of their journey as well as their adventures in the wild gorges among the snow-clad mountains which they traversed. Their experiences with the natives, the numerous courtesies and hospitalities received from the Russian officials, their adventures in search of plants and game, their photographic trials and anthropological researches, fill a large and handsome volume of 335 pages and hold the interest of the reader from beginning to end. A

map completes the list of illustrations, one of which is a picture of the Botanic Garden at Tiflis. A list of new species detected is appended.

ELIZABETH G. BRITTON.

SOCIETIES AND ACADEMIES.

BIOLOGICAL SOCIETY OF WASHINGTON, 247TH MEETING, SATURDAY, OCTOBER 19TH.

MR. SYLVESTER D. JUDD read a paper entitled 'The Food of the Catbird, Brown Thrasher and House Wren,' in which he said that these three birds destroy beetles, ants, caterpillars, grasshoppers and many other insects; also, that the wren is exclusively insectivorous, but that the catbird and thrasher subsist largely on wild fruits, occasionally making inroads on cultivated varieties.

Mr. L. O. Howard spoke briefly of a new enemy of the Hellgrammite fly. In August of the present year Mr. R. S. Clifton called his attention to the fact that the egg masses of the Hellgrammite on the shores of the Potomac River were being eaten by some insect. Investigation showed that the egg masses, which had never before been known to be attacked by any insect, were being eaten wholesale by the larva of *Anthicus haldemanni*, an extremely rare Anthicid beetle. Of the hundreds of egg masses examined none were unattacked. The beetle gnaws a hole through the cover of the egg mass and lays its eggs within. The larvæ feed upon the Hellgrammite eggs until full grown, then crawl away to a crack in the rocks and transform to pupæ.

The speaker claimed especial interest for the observation from three facts: (1.) The egg masses of the Hellgrammite were previously supposed so be uninfested by any insect enemy. (2.) *Anthicus haldemanni* is a very rare beetle, which has never before been taken in the District of Columbia. It occurred in hundreds this season at the point where the observations were made. (3.) Almost no observations are upon record regarding the early stages of the family Anthicidæ. Of the 130 odd North American species the larvæ of none have heretofore been observed.

Mr. Dall showed some fat still containing a

quantity of dried muscular fibres obtained under the following conditions: The geological horizons known as the 'Kowak clays' and the 'Ground ice formation,' from which mammoth remains have been obtained on the Arctic coast, especially at Elephant Point, Kotzebue Sound, appear to be represented in the river deltas of the northern coast of the peninsula of Alaska. Here, near the mouth of the Naknek River, in the spring of 1894 the freshets cut away the clays until the falling bank revealed mammoth bones in the newly exposed portion. The spot was visited by the natives who obtained mammoth bones and a large quantity of fat which they used in greasing their skin boats. The quantity is estimated at 300 pounds. A little later the locality was visited by Mr. W. J. Fisher, who reports that the cavity in the bank of frozen clay still retained something of the form of the body of the mammoth, and under the organic debris, bones, etc., at the bottom, he obtained a piece of the fat in good preservation, which he presented to Mr. Dall, who now exhibited it. Mr. Dall recalled that at Kotzebue Sound, in cavities of the ground ice, he obtained what he believed to be dung of the mammoth, still having a strong ammoniacal smell. It would seem that the present carcass had been more or less demoralized before it was imbedded in the clay, as no mention is made of the existence of hair or skin in connection with the remains, only of disintegrated muscular tissue, bones and fat.

Dr. Wardell Stiles spoke briefly of the proposed memorial to Dr. Rudolph Leuckhardt and of the steps taken by the recent International Zoological Congress in regard to the adoption of an international code of nomenclature.

Dr. C. Hart Merriam spoke on the American Shrews. From a study of about 2,000 specimens he recognizes 60 species and subspecies, 11 of which are restricted to southern Mexico and Guatemala. Of the total number, 18 belong to the genus *Blarina*, 2 to *Notiosorex* and 40 to *Sorex*. The latter genus is subdivided into the 3 subgenera usually recognized—*Microsorex*, *Neosorex* and *Atophyrax*.

F. A. LUCAS,
Secretary.

THE ACADEMY OF SCIENCE OF ST. LOUIS.

THE first Fall meeting of the Academy was held at the Academy rooms, Monday evening, October 21st. Prof. Francis E. Nipher made a donation to the Academy of his new volume on 'Electricity and Magnetism.'

Prof. Wm. Trelease read a paper on 'The Gases Produced by Certain Bacteria,' by L. H. and Emma Pammel.

President Green made mention of the death of Prof. C. V. Riley, one of the former Presidents of the Academy, and announced that he would appoint a committee to prepare a suitable memorial of Prof. Riley's death.

A. W. DOUGLAS,
Recording Secretary.

NEW BOOKS.

- Elements of the Mathematical Theory of Electricity and Magnetism.* J. J. THOMSON. Cambridge, The University Press. New York, Macmillan & Co. 1895. Pp. vi+510. \$2.60.
- An Introduction to General Biology.* WILLIAM T. SEDGWICK and EDMUND B. WILSON. Second edition. New York, Henry Holt & Co. 1895. Pp. xii+231.
- Elementary Physical Geography.* RALPH S. TARR. New York and London, Macmillan & Co. 1895. Pp. xxxi+488.
- Charles Lyell and Modern Geology.* T. G. BONEY. London, Cassell & Co. New York, Macmillan & Co. 1895. Pp. vi+224. \$1.25.
- Missouri Geological Survey, Vol. II.* CHARLES R. KEYES. Jefferson City. 1895. Pp. 405.
- Elements of Geometry.* GEORGE C. EDWARDS. New York and London, Macmillan & Co. 1895. Pp. xii+293. \$1.10.
- Science and Art Drawing, A Complete Geometrical Course.* J. HUMPHREY SPANTON. London and New York, Macmillan & Co. 1895. Pp. xiv+582. \$3.25.
- Reconnaissance of the Gold Fields of the Southern Appalachians.* GEORGE F. BECKER. U. S. Geological Survey. 1895. Pp. 85.
- Catalogue of the Marine Mollusks of Japan with Descriptions of New Species and Notes on Others Collected by Frederick Stearns.* HENRY A. PILSBRY. Detroit, Frederick Stearns. 1895. Pp. vi+196.

SCIENCE

NEW SERIES.
VOL. II. No. 46.

FRIDAY, NOVEMBER 15, 1895.

SINGLE COPIES, 15 CTS.
ANNUAL SUBSCRIPTION, \$5.00.

GUSTAV E. STECHERT'S Recent Importation of Scientific Books.

ADICKES, DR. ERICH. Kant-Studien. 185 Seiten. gr. 8°. Mk. 4⁰⁰.

BENEDIKT, DR. MOR. Die Seelenkunde des Menschen als reine Erfahrungswissenschaft. 372 Seiten. 8°. Mk. 6⁰⁰.

BERNBACH, DR. W. Der elektrische Strom und seine wichtigsten Anwendungen in gemeinverständlicher Darstellung. Mit 90 Abbildungen. 108 Seiten. 8° Mk. 2⁰⁰.

BIEDERMANN, W. Elektrophysiologie. 1^e Abtheilung. Mit 136 Abbildungen. 440 Seiten. 8°. Mk. 9.

BOEGLE, DR. C. Die Entstehung organischer Formen. 18 Seiten. 8°. Mk. 1²⁰.

CAPITAINE, EML. Das Wesen des Erfindens. Eine Erklärung der schöpferischen Geistesthätigkeit an Beispielen planmässiger Aufstellung u. Lösung erfinderischer Aufgaben. 135 Seiten. 8°. Mk. 3⁰⁰.

DELAGE, YVES. La structure du protoplasma et les théories sur l'hérédité et les grands problèmes de la biologie générale. 878 pages. gr. 8° cloth. frs 24⁰⁰.

DÜHRING, DR. E. Wirklichkeitsphilosophie, Phantasmenfreie Naturergründung und gerecht freie liche Lebensordnung. 554 Seiten. 8°. Mk. 9⁰⁰.

FOREL, DR. AUGUST. Der Hypnotismus, seine psycho-physiologische medicinische, strafrechtliche Bedeutung und seine Handhabung. 3^{te} verb. Aufl. mit Adnotationen von Dr. O. Vogt. 223 Seiten. gr. 8°. Mk. 5.

FRICKS, DR. J. Physikalische Technik speciell-Anleitung zur Ausführung physikalischer Demonstrationen und zur Herstellung von physikalischen Demonstrations-Apparaten mit mögl. einfachen Mitteln. 6^{te} umgearb. und verm. Aufl. von Dr. Otto Lehmann. II. Band. Illustriert. 1054 Seiten. gr. 8°. Mk. 20⁰⁰.

GRIESBACH, PROF. DR. H. Physicalisch-Chemische Propädeutik unter besonderer Berücksichtigung der medicin. Wissenschaften u. mit histor. und biographischen Angaben. 1^{ste} Hälfte. Bogen 1-17 mit Figur 1-44. gr. 8°. Mk. 5⁰⁰.

HAACKE, DR. WILH. Die Schöpfung des Menschen und seiner Ideale. Ein Versuch zur Versöhnung zwischen Religion und Wissenschaft. Mit 62 Abbildungen im Text. 487 Seiten. gr. 8°. Mk. 12⁰⁰.

HAMPE, DR. JULIUS. Ueber Geisteskrankheiten in Folge Schwefelkohlenstoff-Vergiftung. 51 Seiten. 8°. Mk. 1⁰⁰.

HANSEN, DR. EMIL CHR. Untersuchungen aus der Praxis der Gährungsindustrie. Beiträge zur Lebensgeschichte der Mikroorganismen. 3^{te} verm. u. neubearb. Aufl. mit 19 Abbildg. Heft I, 92 Seiten. gr. 8°. Mk. 3⁵⁰.

HALLIER, DR. ERNST. Die Pestkrankheiten (Infektionskrankheiten) der Kulturgewächse. Nach streng bakteriologischer Methode untersucht und in völliger Uebereinstimmung mit Robert Koch's Entdeckungen geschildert. Mit 7 Tafeln. 144 Seiten. Text. gr. 8°. Mk. 8⁰⁰.

HITZIG, DR. ED. Ueber den Quarulantenwahn-sinn, seine nosologische Stellung und seine forensische Bedeutung. Eine Abhandlung für Aerzte und Juristen. 146 Seiten. gr. 8°. Mk. 5⁰⁰.

JAHN, HANS. Grundriss der Electrochemie. 311 Seiten. gr. 8° Mk. 8¹⁰.

KROMPECHER, EDMUND. Die mehrfache indirekte Kernteilung. Mit 9 lithogr. Tafeln. 275 Seiten. gr. 8°. Mk. 4⁰⁰.

LEHMANN, DR. O. Electricität und Licht. Einführung in die messende Electricitätslehre und Photometrie. Mit 220 Holzstichen u. 2 Tafeln. 390 Seiten. gr. 8°. Mk. 7⁰⁰.

NOLDE, BARON EDUARD. Reise nach Innerarabien, Kurdistan und Armenien 1892. Mit dem Bildniss des Reisenden und 1 Karte. 272 Seiten. 8°. Mk. 4⁵⁰.

Pharmakologie und Toxikologie mit Beiträgen von vielen Ärzten redigirt von A. Brestaniski. 967 Seiten. gr. 8°. Ladb. M. 25⁰⁰.

RICHTER, CARL. Die Galvanische Verzinkung des Eisens. Mit besonderer Berücksichtigung der neueren Methoden. Mit 18 Figuren im Text. 48 Seiten. 8°. Mk. 1⁵⁰.

SCHMIDT, DR. CARL. Das Naturereigniss der Sintflut. Akademischer Vortrag. 63 Seiten. 8°. Mk. 1²⁰.

WELTER, DR. ADOLF. Die Tiefen Temperaturen, ihre künstl. Erzeugung, ihre Einwirkung auf Tiere, Pflanzen, Microorganismen, etc., sowie ihre Anwendung in der Industrie. 84 Seiten. gr. 8°. Mk. 2⁵⁰.

ZITTEL, KARL A. VON. Grundzüge der Palaeontologie (Palaeozoologie). Mit 2043 in den Text gedruckten Abbildungen. 971 Seiten. gr. 8°. ½ mor. Mk. 25⁰⁰.

ZWAARDEMAKER, DR. H. Die Physiologie des Geruchs. Mit 28 Figuren im Text. 324 Seiten. gr. 8°. Mk. 9⁰⁰.

GUSTAV E. STECHERT,

810 Broadway, New York.

Macmillan & Co.'s New Books.

Loudon and McLennan.—A Laboratory Course in Experimental

Physics. By W. J. LOUDON, B. A., LL. D., Demonstrator in Physics in the University of Toronto, and J. C. MCLENNAN, B. A., Assistant Demonstrator in Physics in the University of Toronto. 8vo, cloth, \$1.90 *net*.

Ostwald.—The Scientific Foundations of Analytical Chemistry.

Treated in an Elementary Manner by WILHELM OSTWALD, Ph. D., Professor of Chemistry in the University of Leipzig. Translated with the Author's sanction by GEORGE MCGOWAN, Ph. D. 12mo, cloth, pp. 207, \$1.60 *net*.

Hutchinson.—Hand-Book of Grasses. Treating of their Structure, Classification, Geographical Distribution and Uses. Also Describing the British Species and Their Habitats.

By WILLIAM HUTCHINSON. With Illustrations. 12mo, cloth, 75 cents *net*.

Laurie.—Facts about Processes, Pigments and Vehicles. A Manual for Art Students.

By A. P. LAURIE, M. A., B. Sc., Lecturer on Chemistry, St. Mary's Hospital; late Fellow King's College, Cambridge. 12mo, cloth, edge cut, \$1.00 *net*.

Stewart.—An Elementary Treatise on Heat.

By BALFOUR STEWART, LL. D., F. R. S., late Professor of Natural Philosophy Victoria University, Owen's College, Manchester. Sixth edition, revised, with additions, by ROBERT E. BAYNES, M. A., student of Christ Church, Oxford, and Dr. Lee's Reader in Physics. New Edition. 12mo, cloth, \$2.25 *net*.

Murray.—An Introduction to the Study of Seaweeds.

By GEORGE MURRAY, F. R. S. E., F. L. S. With 8 Colored Plates and 88 other Illustrations. 12mo, cloth, \$1.75 *net*.

Tait.—Dynamics.

By P. G. TAIT, M. A., Sec. R. S. E., Honorary Fellow of St. Peter's College, Cambridge, Professor of Natural Philosophy in the University of Edinburgh. 12mo, cloth, \$2.50 *net*.

Wiedersheim.—The Structure of Man. An Index to His Past History.

By DR. R. WIEDERSHEIM. Translated by H. and M. BARNARD. The translation edited and annotated and a preface written by G. B. HOWES, F. L. S., Professor of Zoology, Royal College of Science, London. With 105 Figures in the Text. 8vo, cloth, \$2.60 *net*.

Wilson.—Atlas of the Fertilization and Karyokinesis of the Ovum.

By EDMUND B. WILSON, Ph. D., Professor of Invertebrate Zoology in Columbia College, with the cooperation of EDWARD LEAMING, M. D., F. R. P. S., Instructor in Photography at the College of Physicians and Surgeons, Columbia College. With Illustrations. 4to, cloth, \$4.00 *net*. (*Columbia University Press.*)

Keith.—Plea for a Simpler Life.

By GEORGE S. KEITH, M. D., F. R. C., P. E. 12mo, cloth, \$1.00.

MACMILLAN & CO., 66 Fifth Avenue, New York.

SCIENCE

EDITORIAL COMMITTEE: S. NEWCOMB, Mathematics; R. S. WOODWARD, Mechanics; E. C. PICKERING, Astronomy; T. C. MENDENHALL, Physics; R. H. THURSTON, Engineering; IRA REMSEN, Chemistry; J. LE CONTE, Geology; W. M. DAVIS, Physiography; O. C. MARSH, Paleontology; W. K. BROOKS, Invertebrate Zoology; C. HART MERRIAM, Vertebrate Zoology; S. H. SCUDDER, Entomology; N. L. BRITTON, Botany; HENRY F. OSBORN, General Biology; H. P. BOWDITCH, Physiology; J. S. BILLINGS, Hygiene; J. MCKEEN CATTELL, Psychology; DANIEL G. BRINTON, J. W. POWELL, Anthropology.

FRIDAY, NOVEMBER 15, 1895.

CONTENTS:

| | |
|--|-----|
| <i>The National Academy of Sciences</i> | 637 |
| <i>The Thermophone</i> : GEORGE CHANDLER WHIPPLE..... | 639 |
| <i>The Foundations of Medical Science</i> : LIONEL S. BEALE | 644 |
| <i>The Major Premise in Physical Chemistry</i> : ROBT. B. WARDER..... | 651 |
| <i>Remarks on Some Recent Fungi Esiccati</i> : JOSEPH F. JAMES..... | 654 |
| <i>The Bibliographica Zoologica et Anatomica</i> | 656 |
| <i>Current Notes on Physiography (XVIII)</i> :— <i>Mackinder on English Geography; Mountains and Lowlands of Greece</i> : W. M. DAVIS..... | 657 |
| <i>Scientific Notes and News</i> :— <i>Harvard College Observatory; The Department of Insects of the U. S. National Museum; The Third International Psychological Congress; General</i> | 658 |
| <i>University and Educational News</i> | 664 |
| <i>Discussion and Correspondence</i> :— <i>The International Code of Nomenclature</i> : CH. WARDELL STILES. <i>Katydid Orchestration</i> : ELLIOTT COUES, ARTHUR P. BOSTWICK. <i>The Science of Mentation</i> : WESLEY MILLS. <i>Inverted Image Once More</i> : JOSEPH LE CONTE, J. MCKEEN CATTELL..... | 665 |
| <i>Scientific Literature</i> :— <i>Tenth Report of the Northwestern Tribes of Canada</i> : ALEX. F. CHAMBERLAIN. <i>Solution and Electrolysis</i> : THOMAS GRAY. <i>Critical Periods in the History of the Earth</i> : ARTHUR HOLLICK. <i>Eccles' Practice of Massage</i> : GUY HINSDALE..... | 668 |
| <i>New Books</i> | 672 |

MSS. intended for publication and books, etc., intended for review should be sent to the responsible editor, Prof. J. McKeen Cattell, Garrison on Hudson, N. Y.

Subscriptions and advertisements should be sent to SCIENCE, 41 N. Queen St., Lancaster, Pa., or 41 East 49th St., New York.

THE NATIONAL ACADEMY OF SCIENCES.

A SCIENTIFIC session of the Academy was held at Philadelphia, in the Laboratory of Hygiene of the University of Pennsylvania, beginning Tuesday, October 29th, 1895, at 11 o'clock A. M. and continuing through the following day.

A special stated session was held on Wednesday, October 30th, to consider the President's Annual Report to Congress and other business.

The members of the Academy reported in attendance were: Alexander Agassiz, Carl Barus, John S. Billings, Henry P. Bowditch, William H. Brewer, W. K. Brooks, George J. Brush, Edward D. Cope, Samuel F. Emmons, Wolcott Gibbs, Theodore N. Gill, Benjamin A. Gould, Arnold Hague, Asaph Hall, Charles S. Hastings, O. C. Marsh, Albert A. Michelson, S. Weir Mitchell, Edward S. Morse, John W. Powell, Raphael Pumpelly, Frederick W. Putnam, W. H. Welch, A. E. Verrill, Francis A. Walker, Horatio C. Wood and Charles A. Young.

The papers presented were as follows:

OCTOBER 29TH.

I. *On the Paleozoic Reptilian Order of the Cotylosauria*: E. D. COPE. Prof. Cope said that the order Cotylosauria is of much interest from the fact that it is one of the two orders of paleozoic age, because it approaches nearest to the Batrachian class, and because it is the ancestral type of all the Amniota Vertebrata. The order was determined by the speaker in 1870, and is now known to include forms from North America, South Africa and Scotland, in the latter country in Triassic beds. Four families and ten genera are known, and

they range from the size of a caiman to that of a lizard.

II. *On a New Variable of Peculiar Character*: S. C. CHANDLER. This paper relates to the discovery of a new variable which appears, from a study of its characteristics, not to belong to either of the two recognized types of variables of short period. It fluctuates between the magnitudes 8.9 and 9.7 in the singularly short period of five hours thirty-one minutes and nine seconds. It is distinctly not of the *Algol*-type, being in continuous variation during its whole period. Its light-curve is also quite unlike that of the other known class of short-period stars, exemplified by γ Aquilæ and δ Cephei, in which the duration of increase and decrease have the ratio of about one to three; since the increase and decrease of this star occupy nearly equal times, the increase being indeed rather the slower. The variations are very rapid, and maxima and minima are equally and sharply marked, both being observable with the same precision with which we are familiar in the stars of the *Algol*-type, namely, within a very few minutes.

III. *On a Bone Cave at Port Kennedy, Pa.*: E. D. COPE. Prof. Cope reported that the cave seems to be in a fissure of limestone, overlaid with red sandstone. It was discovered in 1870, when, after a blasting, a portion of its contents was exposed and examined by Prof. Cope, who then described 40 species of animals found in it.

About 30 feet have so far been examined, and the bottom is not yet in sight. The further down the diggings are made, the richer the find. On a base of clay, strata of vegetable matter, charred earth, wood and leaves, lie strata of crushed bones, powdered very fine, forming almost a meal.

The number of species so far discovered is 43, some of which have not been previously determined. The bones are those of tortoise, snake, birds, sloths, hoofed

mammals and carnivora. Among the last are found the skunk, bear, and four species of the cat family, including allies of the jaguar and tiger. The teeth of several mastodonts were found, but no traces of elephant. Very many specimens of jaws of the tapir were discovered, as were also the remains of extinct species of horses, differing considerably from the present horse.

Two specimens of teeth of a peccary, and one of an animal probably resembling the South American llama, were likewise taken from the cave. The tiger tooth is very interesting from the fact that, while the genus appears in the caves of America, it has not been found in Europe.

One of the species of bear resembles the existing black bear, while the other is similar to a rare species found in the Andes and California caves, and is not related to any form now existing in North America.

No remains of man have thus far been found, and the cave is probably the best example of the older caves existing prior to the Champlain epoch, or period of submergence, and after the glacial period. The great problem to be solved is, did man exist in North America prior to the Champlain period? If the remains of human beings are found here it will be of great importance, as the geologic time of this cave seems to be well known.

A stone quarry occupies the site of the cave, and blasting was done by Mr. Kennedy in 1840, but fossil bones were first noted in 1870. The bottom of the quarry is now 45 feet below the top of the hill. The bones lie in red clay, and are finely ground up, with here and there a larger mass. The entrance must have been overhead, and the debris brought from a distance and poured in from the top. No marine shells or other evidences of oceanic life have been found. Great blocks of wood, some of it retaining the bark, and nuts, seeds, grasses and leaves were discovered in the cave.

IV. *On Borings through the Coral Reef in Florida*: A. AGASSIZ.

V. *On the Alkali Uranates*: WOLCOTT GIBBS.

The reports by Professors Agassiz and Gibbs were presented informally in the absence of other papers to occupy the session.

OCTOBER 30TH.

VI. *The Olindiade*: W. K. BROOKS.

VII. *New Campanularian Medusæ* (read by title): W. K. BROOKS.

VIII. *The Filar Anemometer*: CARL BARUS. Professor Barus in this paper discussed the sounds by the whistling wind, made whenever air in motion passes across a slender obstacle, like a wire. He showed that the velocity of the wind could be computed from the pitch of the note observed in case of a given diameter of wire and for a given temperature of the air. By aid of a special microphonic attachment such sound could be conveyed to any distance and isolated from the attendant noises at the place of exposure. So represented, the wind was given in every detail of its gusty and variable character, and the term micro-aulmometry seemed to be applicable to observations of this nature. Finally the direction of the gust could be inferred from the sounds obtained from three coördinate wires at right angles to each other.

IX. *The Countertwisted Curl Aneroid*: CARL BARUS. Professor Barus reported that he had investigated the maximum sensitiveness which an extremely thin-walled helical Bourdon tube would show. He pointed out the importance of sharp-edged tubes for the purpose of reducing the flexure of the tube to a case of pure bending, seeing that the products of the principal radii of curvature must then remain constant. He showed that for the same reason the sensitiveness could be enormously increased by untwisting the evacuated coil

with an external spring. Furthermore, if the system of countertwisting spring and helical tube be so chosen that the viscosity as well as the thermal coefficients of viscosity and rigidity of the components are as nearly as possible the same, the system would possess nearly perfect elasticity at all temperatures. The paper was accompanied by a variety of data showing the behavior of simple and countertwisted helices or curls and the remarkable advantages of the latter form.

X. *On the Broadening of Spectral Lines by Temperature and Pressure*: A. A. MICHELSON. Professor Michelson's paper will be printed in the forthcoming number of the *Astrophysical Journal* and will be reported in this journal.

XI. *On the Asteroids* (read by title): A. HALL.

XII. *The Early Segregation of Fresh-water Types*: TH. GILL. [Abstract will be printed in this Journal.]

THE THERMOPHONE.

DURING the recent session of the Summer School of Civil Engineering of the Massachusetts Institute of Technology, held at Keeseville, N. Y., the writer had the pleasure of describing to the students the construction and operation of a new instrument for obtaining temperatures. This instrument, known as a thermophone,* is an electrical telethermometer of the resistance type. It is designed especially for obtaining the temperature of a distant or inaccessible place, but it embodies a principle which may often be used to advantage in scientific work for determining temperatures with greater accuracy than can be obtained with a mercurial thermometer.

The operation of the thermophone is based upon the principle that the resistance which a conductor offers to the passage of an elec-

* Invented by Henry E. Warren and George C. Whipple.

trical current depends upon its temperature, and advantage is taken of the fact that different metals have different electrical temperature coefficients. Thus the resistance of a copper wire increases about one per cent. for each 5° Fahr., while in the case of German silver the increase is only about one-tenth as great. It is a curious fact that the coefficients of most pure metals are almost the same as that of copper, but that alloys have coefficients which are much lower.

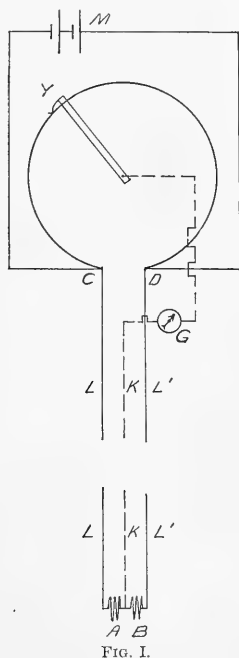

The arrangement of the electrical parts of the thermophone is shown in Figure I. Students of electricity will recognize it as being a modification of a Wheatstone's Bridge. Two coils of resistance wires, A, B, one of which is copper and the other

German silver, are made to form two arms of the bridge. These two coils are joined together and placed at the point where the temperature reading is desired. They are usually drawn inside a long brass tube of small diameter, coiled into a helix and hermetically sealed, the space between the wires and the walls of the tube being filled with oil to prevent corrosion and to hasten the transmission of heat between the outside of the tube and the resistance wires. The sensitive coils are connected by the leading wires L and L' to the ends of a circular slide wire C, D, and at these points connection is also made with the battery M. A third leading wire, K, extends from the junction of the two coils to a movable contact, Y, on the slide wire. In this circuit there is interposed either a galvanometer or a telephone in connection with a current interrupter, the latter being operated by an independent battery connection. This combination of telephone and current interrupter is used in all the portable forms of the instrument and has been found to be a very cheap and efficient substitute for a galvanometer. The presence of a current is indicated by a buzzing sound in the telephone; silence corresponds to the 'zero deflection' of a galvanometer.

Bearing in mind the principle of the Wheatstone's Bridge it will be seen that the galvanometer will indicate 'zero deflection' when $A:B = CY:DY$. The coils A and B being made of metals having very different temperature coefficients will vary in resistance at different rates as their temperature changes, and consequently there will be a different value of the ratio of A to B for each degree of temperature. Thus it will be seen that with the bridge balanced there must be a different position of the contact Y for every degree of temperature, and a graduated scale may be constructed corresponding to the temperature of the sensitive coils. The slide wire is wound

around the periphery of a mahogany disc, above which is another disc carrying a dial graduated in degrees of temperature. The movable contact which bears on the slide wire is attached to a radial arm placed directly under a hand on the dial, the two being moved together by turning an ebonite knob in the center of the dial. This indi-

the reading of the instrument, for being made of one piece of metal which has the same temperature throughout its length, it will rise or fall in resistance at the same rate on both sides of Y as its temperature changes, and consequently the ratio of CY to DY will not vary. The effect of temperature changes on the leading wires will not

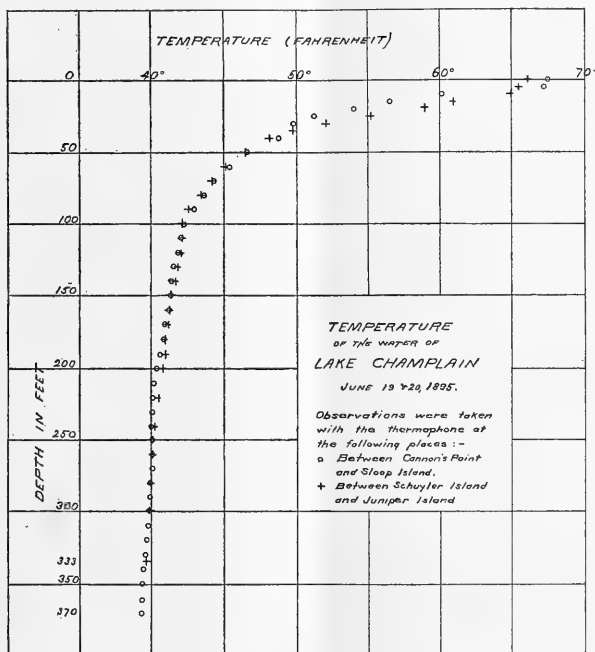

FIG. II.

cator is enclosed in a brass case attached to the box containing the battery, telephone, etc., the box being about 7 inches square and 10 inches high, and furnished on the outside with binding posts for the reception of the leading wires.

It is easily seen that the temperature of the slide wire has absolutely no effect upon

sensibly affect the readings because the two wires L and L' are on opposite sides of the bridge, and consequently balance each other. Compared with the resistances A and B these leading wires are of large size, and in order that they may have the same average temperature they are twisted together and covered with braided cotton.

The operation of taking a reading with the thermophone is as follows: The helix containing the sensitive coils being placed at the point where the temperature is desired, and the leading wires being connected to the binding posts of the indicator box, the current is turned on and the telephone held to the ear. A buzzing sound in the telephone is found to increase or diminish as the hand is made to approach or recede from a certain section of the dial. By moving it back and forth a position may be found where the telephone is silent. When at this point the hand indicates the temperature of the distant coils. The instrument is extremely sensitive. An inexperienced observer may easily set it to one-tenth of a degree. With special instruments having a small range it is possible to make readings with much greater precision.

One of the uses to which the thermophone was put at the Summer School was that of ascertaining the temperature at various depths and at various places in Lake Champlain. A large number of observations were taken. The accompanying diagram, Fig. II., shows the results of two sets of observations taken where the depth was 333 and 396 feet respectively. It will be noticed that below a depth of 50 feet the readings at the two places agreed almost exactly; above that point they differed somewhat, but each curve preserved its regularity. It is interesting to observe how great a change of temperature there was in the first 50 feet below the surface, and how slight a change there was near the bottom. At a depth of 100 feet the water was but 3° warmer than at the bottom.

At the deepest place in the lake, which was found opposite Essex, N. Y., the temperature at 370 feet was 39.35° F., a point only slightly above the temperature at which water is densest. Unfortunately the thermophone wires were not long enough to reach to the bottom, which was 396 feet.

The fact that this temperature so near the point of maximum density was found during the summer season indicates that the water near the bottom is in a continual state of stagnation. It is probable that there is little circulation below a depth of 200 feet.

In passing it is interesting to note the growing interest that is being taken in the study of the temperature of lakes in connection with that of the micro-organisms in the water. The seasonal occurrence of many of these forms which cause trouble in water supplies has been shown to be directly connected with the vertical circulation of the water. Knowledge of the extent and character of these vertical currents can best be obtained by observing the temperature of the water at different depths.

One of the most interesting of the special uses of the thermophone principle is in connection with the accurate measurement of distances by means of a steel tape. Heretofore the greatest objection to the use of a steel stape for the measurement of a base line has been the alterations in its length due to varying temperature and the impossibility of correctly ascertaining its temperature at the moment of use. Thermometer readings taken alongside the tape, or even with the bulb in contact with it, cannot give its exact temperature. Especially is this true when the work is done in the daytime and with the sun shining. For this reason the most accurate work has usually been done at night when the temperature of the tape is substantially the same as that of the air. By the application of the thermophone principle the tape itself may be used as a thermometer and its exact temperature easily determined. This was experimentally demonstrated at the summer school at Keeseville, where the apparatus was used for the first time.

The steel tape, 100 meters in length, was suspended a few feet above the ground between two iron poles which bore an ingeni-

ous device for keeping the tape stretched at a uniform tension. At intermediate points, 10 meters apart, the tape was supported by insulated wire hooks. Parallel to the tape, but insulated from it, a German silver wire was suspended in a similar manner except that the tension was not regulated. At the rear end the tape and wire were electrically connected; at the forward end short flexible leads connected the tape and wire with the slide wire of the indicator. A third wire trailing along the ground, connected the junction at the rear end with the sliding contact of the indicator, having in its circuit the telephone and interrupter. The arrangement was precisely the same as in the ordinary instrument, the tape and German silver wire acting as the sensitive coils. The connections with the tape were made by adjustable clamps which could be easily removed when it was time to carry the tape to a new position. The indicator box was conveniently placed near the forward end of tape, and readings were taken in the ordinary manner by holding the telephone to the ear and setting the hand on the dial to the point of silence. The dial bore two graduations, one showing the temperature of the tape, and the other the linear correction corresponding to the temperature. Thus it was possible, by a single reading taken at the instant when the measurement was to be made, to determine the amount necessary to be added to or subtracted from the length of the tape.

The experiments at Keeseville consisted of the measurement of a base line 900 meters in length and an accurate determination of the coefficient of expansion of the tape. The results showed conclusively that the error from temperature could be reduced to one part in 1,500,000, which was well within the precision of other portions of the work. The coefficient of expansion was determined by two sets of observations,

the results being 0.00000613 and 0.00000615 respectively.

An interesting set of observations was made on the temperature of the tape at a time when clouds were passing over the sun. The rapid fluctuations were astonishing and indicated that the tape was much more sensitive to temperature changes than a mercurial thermometer. At times when a dark cloud would suddenly obscure the sun the temperature of the tape would drop ten or fifteen degrees in half a minute. A complete account of these experiments will be published in due time.

The thermophone has also its practical uses, which are as varied as the uses of a thermometer. For use in connection with the ventilation of buildings it possesses qualities which make it more valuable than the ordinary telethermometer. Besides being accurate and comparatively inexpensive it has this further advantage that any number of sensitive coils may be connected to one indicator. Thus in a large schoolhouse a sensitive coil may be located in each room and the leading wires carried to an indicator in the janitor's office, where, by using a switch board, the janitor may read from one dial the temperature of any room in the building.

In buildings it is advisable to dispense with the telephone and current interrupter and use a galvanometer so arranged that the temperature of the distant coil is indicated by the deflections of the needle. With such an arrangement it is only necessary to press a button in order to have the needle automatically indicate the temperature.

In conclusion, it should be remarked that the thermophone is admirably adapted for obtaining high temperature, *i. e.*, up to 1,500 or 2,000° Fahr., and will doubtless find an extensive use in boilers, chimney flues, etc. It is also the purpose of the inventors to make the instrument self recording.

GEORGE CHANDLER WHIPPLE.

THE FOUNDATIONS OF MEDICAL SCIENCE.*

THE extraordinary advance which has characterized nearly every department of science during the past fifty years can hardly be said to have helped the solution of that most important of all problems, the very foundation of natural science—the nature of life. To us engaged in the study of disease and the relief of suffering it is—and from more than one point of view—a fundamental question, one which from the earliest times has been regarded by the medical profession with the keenest interest. Time after time scientific enthusiasts have announced in the most confident terms, and for more than forty years the public have been assured again and again, that at last the mystery had been solved or was so near solution that it might be considered as practically settled. Among scientific workers and thinkers, however, the divergence of opinion as to the real nature of life has been, and is, so great that we are still uncertain how any living thing is formed, how it grows, what is the exact nature of many diseases, and in what manner the action of many of our medicines is to be correctly explained; while, notwithstanding great progress in investigation, many morbid changes and phenomena connected with the healing of wounds and the repair of injuries have yet to be cleared up before we shall be able to say that the nature of vital processes is understood. The very foundations—the first principles of all living nature, the exact differences between the living and the non-living state—have still to be established. Even the broad differences between a particle of matter which is actually living and one that has just

ceased to live have not been ascertained, and our physiology, pathology and medical science rest upon no certain basis. Mental operations have received various explanations, but not one that has been offered adequately accounts for the facts, while vague and uncertain data and conflicting interpretations of facts form the foundations upon which uncertain and perpetually changing philosophy has been constructed. So strong, however, is the conviction of some with regard to the truth of the physical doctrine of life, and the generalization that the living and non-living are one, that not a few would modify our systems of government and education in order to bring them into accordance with certain fanciful speculations upon the religion, morality and civilization of the future when physical doctrines shall be universally accepted and taught.

So determined has been and is the set of opinion against the idea of the operation in living beings of anything in its nature distinct from physical or chemical change that I have long hesitated to press a contrary view, notwithstanding that facts and arguments in all departments of living nature give to it very strong support; while, on the other hand, the favorite doctrines still taught are contrary to all living nature, and to make them popular it has been necessary to invent a new nature—a nature which from the first has been shown to be impossible. Lately, however, a change has come over men's views. Not a few have begun to doubt whether the purely physical doctrine of life is supported by facts, and at last the distinguished President of the Chemical Section at the Ipswich meeting of the British Association has dared, not only to express his doubts concerning the purely physical doctrine of life, but has gone so far as to plead 'for a little more vitality.' I heartily join in his plea, and have for many years hoped that ere long we should be per-

* An introductory lecture delivered at King's College Medical School on October 4th, 1895, by Lionel S. Beale, M. B., F. R. C. P. Lond., F. R. S., Joint Professor of the Principles and Practice of Medicine in King's College, London, and Physician to the Hospital.—Abridged from the report in *The Lancet*.

mitted to admit the operation of a vital, constructing, arranging, guiding and regulating power working in everything that has life. I have endeavored to show exactly where this power operates and upon what, and have drawn attention to the fact that the living matter or 'bioplasm' possesses very similar powers in all living things, from the lowest to the highest. For the most part the plea has been in vain, and overwhelming authority has declared for the opposite view, and that those who differ, being weakest, are to go to the wall.

This question of the nature of life forces itself upon our consideration in all our deeper medical and physiological inquiries and in all attempts to decide upon the foundations of natural knowledge. Not only are intellect, thought and the countless workings of the mind inexplicable upon physical doctrines, but the movements and growth of the very simplest living forms are due to far more than is comprised in purely physical and chemical changes. Is not life-power the real, directing, controlling, regulating and selecting agency in every form of the living? How can we accept the proposition that from non-living atoms and their properties is somehow evolved a power which determines the arrangement of these very atoms, which places them in already determined positions, that tears them away from one another and then brings them within the sphere of their influence so that new and totally different substances result? Could watches and engines make themselves, and multiply, regulate and direct, set themselves in motion, and stop when they willed to do so, some comparison might be made between machines and living matter. I feel sure that all intelligent persons will agree with me in thinking that the time has arrived when this matter should be thoroughly reconsidered. The influence of vitality upon matter as a guiding and directing agency—as a

power by which the elements of matter may be torn away from one another, rearranged and caused to recombine in a way unknown to physics and chemistry—has yet to be recognized, and, if possible, investigated. That this power is transmitted from living particles to lifeless ones, which then live, is certain; equally certain is it that all living matter is clear, transparent, structureless and as colorless as pure water. These are the characters of the simple substance in which vital changes are effected without machinery and without any apparatus. This living matter or bioplasm is, I believe, the foundation of all living nature, the seat of all vital phenomena in health and disease, and the only substance in nature possessing powers correctly termed vital. Is there not evidence that in every kind of living matter the elements of the substance that lives may be separated and rearranged in an order determined beforehand, and in such a manner that definite compounds result and structures evidently designed for definite purposes are formed to do certain work? Have any such phenomena been explained by physics and chemistry? Consider whether any machine has been constructed that can perform work and be kept for any length of time in working order without the designing, regulating, managing power of the living mind. Where is the laboratory that performs chemical operations without the chemist? And where is the matter that can be subjected to analytical and synthetical operations without the intervention of some living agency? And yet it has been affirmed again and again that the living cell is a lifeless laboratory, where work of the most complex kind is carried out without any designing, directing or controlling agency whatever. It is often assumed that substances of chemical simplicity are more easily changed in vital action than bodies of great complexity of composition; but so

far as we have evidence complexity and simplicity of composition are equally overcome by living power. The change seems to be carried out in all cases in the most perfect manner, and very quickly. The view of the building up from simple to complex is not justified. The atoms seem to take up their appointed positions and relations as if impelled by an irresistible power, and according to the same principles in every case, from the lowest to the highest organisms.

The members of the profession and all students are to be congratulated upon the addition, during the past three years, of a new subject to those which have long formed the basis of medical education. The careful study of elementary biology must now be taken up by every medical student in the early part of his course. He has to work with the microscope and to become familiar with the use of instruments for delicate research which were not known to the advanced investigators of fifty years ago. Every student acquires real knowledge of the minute structure of the body, and may form his own conception of the general nature of the wonderful changes characteristic of living things, from the lowest organisms to man himself. I hope you have all seen what happens when a particle of living matter, say, of an amœba, exhibits what we call vital movements, and have observed portions moving away from the general mass. Such portions, becoming detached, begin a new and independent life, taking up nutriment on their own account, and growing like the parent organism from which they have been detached, or have detached themselves, and at length increase and multiply and at last die, like all other things that live. Some have affirmed that this living matter is 'like' a mixture of oil and mucilage, but those who have studied practical elementary biology will not be misled by such a 'likeness.' Would that people generally could also

study some of these simple living organisms and learn the differences between that which lives and assimilates, and grows and dies, and that which does not live. No one who had thought over what he had seen would be persuaded to assent to the proposition that the clear structureless living matter should be regarded as a form of machine, molecular or otherwise. When you examined this living matter under a high power I am sure you must have felt astonished that any one could speak of such a thing as a mechanism or as a laboratory. The moving projections or diverticula just alluded to, like those of leucocytes and pus and mucus corpuscles, are well deserving of your further attentive study. Watch carefully the movements and notice how very clear and transparent is the moving matter. In some you cannot discern a single granule even with the aid of the highest powers, and I think when you do see granules and carefully study their movements you will agree with me in the conclusion that it is not in these visible granules that the moving power resides, but that the visible particles are moved by the clear, soft, structureless substance of which the diverticula consist. The process of growth may continue by the taking up of non-living matter by the transparent, moving, living substance and the communication to it of amœba life, through generations. The process has proceeded for thousands of years, but whether an atom of the matter of the parental organism remains, except for a very short time as a constituent part of the detached descendant, seems to rest upon too fanciful a basis to entitle the living changing matter to be regarded as *immortal*. Think over what you have seen and consider how the wonderful movements are occasioned, how the living matter communicates its powers to the non-living and grows and multiplies. Can it be merely chemical change or me-

chanical action that produces the result? When and what is the machinery said to be present, and how is any 'molecular mechanism' to be demonstrated in such transparent substance? *Authority* alone steps forward and insists upon laws and properties and tendencies, declares to us what we are to believe, and prophecies what our successors will discern in the future.

Before the year 1860, after having carried on observations upon the tissues of plants and animals in many departments of living nature, and from the earliest period of development to the fully formed state and into old age, under the highest magnifying powers (from 700 to more than 2000 diameters) and with great advantages as regards the preparation of specimens, I was led to draw a distinction in each tissue, organ or organism between the living growing formative matter and that which had been formed and could not reproduce itself or give rise to more formed matter. I was gradually led to the general conclusion that every form of the living, growing matter was absolutely distinct from every kind of the resulting formed matter produced by it, and, further, that the influence upon the non-living pabulum was peculiar and belonged to all living matter, but to this only, and that it was not comparable with, or allied to, any other known property, power or action of matter. These conclusions were illustrated in detail and were published in 1861. The preparations were shown to my class of physiology in this College and during lectures at the Royal College of Physicians of London, and further discussed in memoirs published in the Transactions of the Royal Microscopical Society and in several works published at that time and since. It seemed to me that there were no indications whatever of the faintest analogy between the two kingdoms of nature—the living and the non-living—no indications of any gradation from matter in the non-

living state to that of life, while all living matter, from the very lowest to the very highest, exhibited certain common characters, being always colorless, structureless, capable of independent movement as a whole or in part, capable of growth, with a power of selecting certain substances and rejecting others, having structural formative power and powers of affecting chemical change, rendering it certain that the origin of matter so endowed was not direct from the non-living, and that this doctrine sooner or later would have to be abandoned. The warmest advocates of the latter view have never given adequate reasons for the faith they professed, or answered the many objections advanced against the conclusions they accepted and taught. All the particles of living matter actively concerned in the formation of tissues and organs, easily seen under a power of 200 diameters, are less, and most of them considerably less, than the $\frac{1}{10000}$ part of an inch in diameter. In the absence of such living particles nothing can be formed or secreted. If we are to form any accurate conception of the actual phenomena which occur when some of the matter of these minute living particles is resolved into tissue or secretion, it is necessary to study the matter very attentively with the aid of the highest powers, and then we can expect only to learn some of the broader changes which occur. The actual conversion probably occurs in particles of matter far more minute than can be discerned with the highest powers at our disposal. Most important facts, however, have been demonstrated with reference to the movements of many of these bioplasts. Where fibrous or other tissues are formed which are to be laid down in parallel lines the fibre is as it were spun off as the particle of living matter (bioplast) moves upwards or downwards along the tissue already formed, and thus fibre after fibre is added to those already existing. In some

tissues the bioplast moves round and round the cell cavity, thus forming concentric fibres or layers. Such bioplasts, evenly distributed through all the tissues and organs of the body, even in the solid bone, take part in the formation of the tissue around, may exist through life and change very slowly in health, most of them getting smaller as age advances. These are instrumental in establishing the passage of fluid to and fro in the interstices of the tissue. By this continual flow the integrity of the tissue is preserved and the occurrence of degeneration is prevented or postponed. Anything favoring the passage of more nutrient fluid than the very small quantity required by these slowly living particles favors their enlargement they live too fast. They increase in size, and this change is constant in every form of inflammation and fever. With the enlargement there is invariably rise in temperature of the surrounding part and of the blood as it traverses the nearest capillaries. When this change, as in fever, affects the bioplasts of many tissues of the body and is widely distributed, the temperature of the whole volume of blood is, as we know, raised several degrees, but falls with the diminution of the febrile symptoms, as the bioplasts return to their ordinary condition. If in ordinary inflammation the process continues and increases, the bioplasts give off diverticula which may be detached, and at last 'pus corpuscles' result, and the adjacent structures are destroyed. In all pathological changes these bioplasts take part. The health of the body depends upon the normal state of the bioplasts, and movement and changes continue while life lasts. Their life is destroyed by many poisons, notably by hydrocyanic acid, the proportion of 1 in 100,000 in the blood being probably sufficient to destroy the life of adjacent bioplasts in a few seconds. You must have seen multitudes of these bioplasts

disseminated through the tissues which you have examined, and have, no doubt, studied their arrangement in different tissues and organs, though, perhaps, from their being perfectly colorless you may not have regarded them as the most necessary part of the organism. Without them no tissue or organ could have been formed, could have preserved its integrity, or, in case of injury, could have been repaired. They are the life of the body, and without them nothing can live; they constitute the living part of the body—that is, the matter that dies. In cases of fever and inflammation, and in various conditions in which there is increased flow and facilitated access to the bioplasm of nutrient matter in any tissue or organ, one sees, after the altered state has lasted for a short time, arising here and there in various parts of the bioplasm minute dots, which gradually become large enough to be seen easily and are known as nuclei. If the process continues some of them become much larger, and in them new points appear (nucleoli). This is an example of true evolution, as the bodies in question are new centers of living matter, which arise in already existing and perfectly structureless bioplasm.

Not only as long as life lasts is the substance of which living matter is composed in constant movement and portions caused to change in position, but the very elements of the matter, however strongly they may have been united in the non-living condition, are caused to separate, and not only are they rearranged, but they are rearranged in a definite and predetermined manner which differs in different organisms and in different tissues and organs of the same organism. Such movements, of course, can only be represented to the mind, since the movement spoken of and the affected particles themselves are far beyond the present range of our vision, assisted as it may be to the utmost with the

aid of very high magnifying powers. The movements we are considering in very minute particles of living matter take a general direction from center to circumference, and the places of those which have taken a centrifugal course are taken up by the pabulum, the flow of which is centripetal. It is, in fact, in these centers, far removed from our powers of vision, that life power seems to be communicated to the matter, and here the non-living matter begins to live. Life causes elements, however strongly combined, to separate, and overcomes the physical and chemical attractions of elements in combination. Life is able to raise particles above one another in a manner not explained. Of the rearrangement of the component atoms of matter, and of the alteration of their relation to one another during the living state, there can be no doubt, but how this is effected has not yet been ascertained. This rearrangement is different in the different kinds of living matter and results in the production of certain special substances, constant as regards living matter of the same kind under the accustomed natural conditions.

So far, then, we seem to have arrived at this, that the matter of the body actually living can be distinguished from the material which is formed by changes occurring in any portion in which vital phenomena have ceased. For instance, in the growing 'cell' of epithelium the central part is structureless and is alive, and its particles can grow and multiply. The outer part has structure, but no longer manifests vital phenomena. It cannot produce matter like itself, or grow, or select nutriment, or exhibit spontaneous movements. Just at the point where the formed material and the living matter touch, particles of the latter from time to time cease to exhibit vital changes, and the resulting products become formed material which is added to that already produced. Such changes occur everywhere

in living organisms, from the first to the last moment of existence, whether 'high' or 'low,' 'simple' or 'complex.' *Vital change* is one thing, physical and chemical change another, and no particle of matter is the seat of these two classes of changes at the same moment. But there are other wonderful powers associated with the living condition, known to all but understood by no one, some of which I shall now briefly refer to. With regard to the marvellous power which a speck of living matter may transmit without loss to descendants during centuries, only think of this: The oldest variety of pigeon, bred for many generations without loss, and perhaps with improvement, of its remarkable characteristics, and bear in mind not only as regards color, form and number of feathers, but widely diverging from its original progenitors as to the characters of bones, muscles, nerves and other tissues; as to habits, manner and disposition, as to powers of flight—in fact, as to many particulars which would lead us to regard it as a true species far removed from the rock pigeon—in short, having little in common with that species—nevertheless carries, apparently fixed and unalterable in its organization, not a new tendency, but an inalienable compulsion if left to nature for its offspring to revert to the ancestral characteristics; not immediately, but after a few generations its descendants exhibit the original specific characters, having lost all traces of the variety which but a few (often only three or four) generations before might have been regarded as a definite species of pigeon. And, further, think of this, that every rock pigeon, generation after generation, has possessed deeply ingrained, as it were, in its organization the power of transmitting to descendants the capacity of giving origin to any or several varieties of pigeon that are known, and perhaps to many more varieties not dreamt of, and at the same time to every variety

the power of reversion to the original species, if only each individual is allowed to choose its mate as in a natural state. Consider the constancy and, on the other hand, the wonderful plasticity of the organization of this familiar but remarkable bird. Contemplate the wonderful power of change from, and the more wonderful power of reversion to, the original type transmitted through generation after generation and retained through centuries, the only medium being a speck of matter so minute that it would not be indicated by a very delicate balance, and tell me whether you think it probable that the powers referred to are due to the original material properties of the fragment of matter concerned, or whether this acts only as a carrier of the marvelous power belonging to the living world only and originating in the infinite. Never before the present time was there any possibility of approaching the thorough investigation of the important question of life. Our much wider range of knowledge concerning the structure and action of many living organisms widely separated from one another has, in fact, enabled us to consider the question from many new points of view; and, although the issue between contending parties is perhaps more pronounced than ever, the probability of arriving at the truth has immeasurably increased, if, indeed, it has not already reached something approaching certainty. It is curious that, although knowledge of minute structure and of the actual phenomena characteristic of living matter has been widely spread, the important question of the nature of life and its resemblance to and differences from all physical and chemical actions known has only been very imperfectly debated. One would think that the inquiry lay far away from the paths familiar to most educated persons, but the most important points bearing upon the inquiry can now be made intelligible to edu-

ated minds without much difficulty, so that many thoughtful persons may be able to form a judgment of their own, at least concerning the direction in which the truth will probably be discovered.

Among the broad and well-known facts, then, not to be explained by the physical view of vital actions is the vast subject of heredity so remarkable in every department of nature, both for the long periods of time of its continuous operation and for the magnitude and enormous importance of the results when considered in connection with the very minute quantity of matter concerned. Is the transmission of characteristics of minute structural details of extraordinary constancy handed down from generation to generation for hundreds or thousands of years by the very minute particle of matter which we know to be concerned in the process to be attributed to the physical properties and chemical composition of the matter involved or to vital power communicated to this from the immediate predecessor?

We have now followed the phenomena common and peculiar to all living to the seat of their activity in living matter. In centers far more central than our present means of investigation will permit us to penetrate living particles communicate, and without loss, their marvellous powers to some of the recently selected molecules of the non-living pabulum. It would seem that now for a time the ordinary properties of matter are held in suspense or are overcome. Here occur analytical operations of the most stupendous kind, which are carried out very quickly and in the quietest manner, without apparatus or reagents, and without resort to a high temperature. The matter which is the seat of these phenomena is as clear as water, structureless, and composed of very few elements which, if the matter dies, easily take the form of an albuminous substance with fatty matter and salts. During the living state the atoms of the mat-

ter, if there be atoms, may be torn from one another and made to take up new and definite relations, so that by synthesis there arise new substances with new properties, perhaps exhibiting structure and capable of performing purposive action of the most striking and at present inexplicable kind; motion, heat, light, electricity, being manifest in certain cases among other phenomena, while there are present no arrangements, conditions or apparatus such as would enable us to develop these independently of the living. Here, then, as it seems to me, will be found the foundation not only of the principles of physiological, pathological and medical science, but of that of the whole living world as distinguished from the lifeless cosmos. Here we must look for the initiation of all the changes characteristic of the living state. Account must also be taken of these peculiarly vital phenomena in discussions concerning consciousness, thought, and will, and the life that has been, is and is to be. And may we not even hope that by further and deeper study of the phenomena of living matter under the new advantages of demonstration which we enjoy, and which are constantly progressing, some further light may be thrown by the increased skill of investigators of vital phenomena even upon the nature and relationship of material atoms in that boundless world of the non-living which ever has been and must be regarded alike by learned and unlearned with wonder and admiration?

LIONEL S. BEALE.

LONDON.

*THE MAJOR PREMISE IN PHYSICAL CHEMISTRY.**

CHEMISTRY is essentially an inductive science, mathematics is essentially deduc-

* Abstract of a paper prepared by request, to introduce the topic of Physical Chemistry, for the American Association for the Advancement of Science. Read Sept. 2d, 1895.

tive, while physics holds an intermediate position. Yet in our own science, generalizations are reached from time to time, which serve as major premises for syllogistic reasoning. For example, the proposition that each portion of matter has constant weight is at the basis of our knowledge of chemical equivalents as determined by the balance; the isolation of the metals of the alkalis and alkaline earths led to an insight into the nature of salts in general as metallic compounds; and the 'periodic law,' though not expressed in precise mathematical language, is a most fruitful generalization of generalizations.

Physical chemistry, following the logical methods already so largely adopted in physics, is characterized by a readiness to use the major premise. Instead of making a separate experiment to answer each question of fact, the conclusion may often be reached on theoretical grounds, in the same sense as an engineer may demonstrate the stability of the structure he has designed, or the movements of a newly invented machine. What, then, is the leading major premise in modern chemistry? and what shall be the conditions of fruitfulness?

The doctrine of energy, as based upon thermodynamics, embraces the two laws of conservation and correlation; first, energy (while convertible from one form to another) is constant in amount; second, while work may be wholly converted into heat, only a definite fraction of heat can be converted into work. To specify more clearly, if a quantity of heat, H , is received at temperature T (from absolute zero), and if this is converted into work as far as possible by any ideal process until there remains the quantity H' at temperature T' , then the simple theorem holds that the two quantities of heat are proportional to the two temperatures; and of course the difference between heat received, and heat remaining (that is, the work) is proportional to the

difference in temperature. Or, in algebraic language,

$$\begin{aligned} H : H' &:: T : T' \\ H : H-H' &:: T : T-T' \\ \text{Work,} = H-H' &= \frac{T-T'}{T} \cdot H \end{aligned}$$

This equation shows what *fraction* of the heat may be converted into work, under the most favorable conditions; namely, the fall in temperature divided by the absolute temperature at which the heat is supplied.

My present purpose is to present this topic in its bare outlines, and with the greatest simplicity possible. Those who wish to follow the deductive reasoning in detail must use the notation of Calculus, in accordance with the following steps. Combining the formula for the total work (as implied in the first law) with that for work derived from change of temperature (the second law) we deduce a differential equation for the work obtained or required in isothermal changes. The change under consideration may involve external work, as when a vapor or gas is generated against atmospheric pressure; or it may be internal work of different kinds, as when the molecules are endowed with increased kinetic energy in volatilizing, or when a compound is decomposed into its constituents, with increased potential energy.

A somewhat difficult but important paper by J. Willard Gibbs* treats of the equilibrium of heterogeneous substances, giving deductions from the two laws of thermodynamics, which in turn become major premises for a host of further deductions; so broad, indeed, are the propositions of Gibbs, that the distinctions between chemistry and physics do not appear; there may be two 'heterogeneous substances' of like chemical nature, as water and its vapor;

there may be three chemical bodies, as limestone with the lime and the carbon dioxide obtained by ignition; or there may be several physical mixtures, as solution of water in ether, solution of ether in water, and the mixed vapor resting upon both liquids. Now, a little consideration will show the importance of knowing when equilibrium is established, for this is equivalent to saying that no further action can take place; the solution is saturated, no longer acting upon the salt; or the gas which has been generated under pressure is no longer evolved. When a change takes place spontaneously, as when I drop a stone, or mix sulphuric acid with water, heat is developed from some other form of energy. To reverse the process, work must be done. The conversion of heat into work is limited by natural law; when a given change implies the doing of work, and that work is forbidden by the terms of our major premise, the change is impossible, equilibrium prevails.

'Osmotic pressure' in dilute solutions is analogous to the pressure of gases; the Gay-Lussac-Marriotte law, with slight modification of terms, applies to molecules in the liquid state. If work is required to diminish the volume of a gas by means of pressure, work is likewise required to diminish the volume of a body in dilute solution, whether the solvent be removed by evaporation or by freezing. Boiling point and freezing point of the solvent are changed by the presence of the dissolved body. The agreement of observed facts with theoretical deductions has led to important methods of determining molecular weights, while the apparent discrepancies in the case of electrolytes have proved an important argument for the doctrine that these compounds are dissociated into their ions.

Our Chairman has pointed out the mutual indebtedness of technology and pure

* Trans. Conn. Acad., 3, 108, 343 (1874-78). See, also, Amer. Jour. Sci. [3] 16, 441 (1877); 18, 277 (1878).

science. Manufacturing processes afford many examples of change which are not carried to completion; it is important to know how far the operation can be improved to afford a larger yield, a purer product or less waste. Combustible gases issue from the blast furnaces. There is still a great reducing power in this mixture of carbon monoxid with carbon dioxid. Can it be utilized by enlarging the furnace? Immense furnaces were built in order to secure a larger yield of iron, but the results were disappointing. The law of mass action shows that the equation

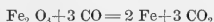

is limited by certain conditions of equilibrium, and that the ratio of the two oxids of carbon could not be greatly improved over that already secured in practice. The expense of a technological experiment might have been saved, had the indications of mathematical chemistry been heeded.

What hopeless confusion seems to prevail in our present knowledge of solubilities; yet how important in the separations required for chemical analysis. Here, again, we deal with questions of equilibrium. Will work be done at the expense of heat or not?

There are two special difficulties in the general application of thermodynamical principles; first, the minor premise is often wanting; and, second, the mathematical form of reasoning is often difficult for the best laboratory workers. Among the published data of thermo-chemistry, some have been determined directly, some indirectly; it is often difficult to find the data desired or to judge of their accuracy. A critical compilation of all available thermal data, conveniently arranged for reference, with at least some indication of the probable errors, would be very desirable. Many such data might be computed indirectly from experimental determinations of equilibrium.

Many empirical equations have been computed, showing solubility as a function of temperature. Who will trace the correlation among such, and thus add a large chapter to thermo-chemistry? What genius shall discover that form of mathematical function that shall substitute rational for empirical equations with a clear interpretation for each constant required? "But this work is mathematical rather than chemical," you will say. Yes, it is applied mathematics; and mathematicians (not being chemists) are not likely to undertake such a task for us, unless we ask their counsel and aid. Specialization is inevitable; yet by too arbitrary a specialization, we may inadvertently lose the very help we need. Again would I emphasize the fruitfulness which follows a 'cross-fertilization of the sciences.*' Judging from the advances recorded in late years, especially in the '*Zeitschrift für physikalische Chemie*,' it is safe to predict great developments for the rising generation. I heartily echo the sentiment that we need more data; yet great stores of observations upon record have not yet been coördinated and put to use. Ostwald, desiring to know the influence of free iodine upon a reduction process, made three series of determinations (twenty-four in all) from which he concludes that the influence is *not* proportional to the mass. It was no part of his purpose to discover what the law of retardation is; but others might well follow out this clue, using also the data supplied by Meyerhoffer, and supplementing these with further experiments if needed. A glance at the literature of solubilities, and the lack of rational formulas to express broad generalizations, may convince us that a great mine, with abundant ore 'in sight,' is awaiting development; or, rather, that ore has been run through a stamp mill to extract half the gold, while fully half still remains in

* Jour. Amer. Chem. Soc. 15, 601 (1893).

the tailings, awaiting more perfect methods of treatment.

Much may be learned from the systematic habits of the astronomer, dividing his work among the several observatories in a spirit of helpful cooperation, and assigning the labor of computation to those who are fitted thus to follow the lead of others. What better service can we do for the University student than to set before him some of the problems in mathematical or physical chemistry that require patient toil, and give him the pleasure of assisting in their solution by the use of logarithms and squares? What is more practical than to utilize any service he can render?

In conclusion, I beg leave to suggest the appointment of a joint committee (representing Sections A, B and C of the American Association) to consider the feasibility of striving towards the following ends:

1. The compilation of all reliable data of physical chemistry in convenient form for reference, distinguishing those determined directly from those calculated indirectly.

2. The calculation of empirical formulas, to combine any series of data, when some better form of generalization is not already at hand.

3. The preparation and use of rational formulas, wherever possible, to deduce the natural constants from series of observations, and to express the conditions that may be expected to hold between observations of different kinds.

4. The organization of a band of volunteer compilers and computers from among advanced students, who (with the counsel and aid of their instructors) may assist in the work of compiling data and computing formulas.

☞ While the time did not seem ripe for the appointment of such committee at the late meeting of the A. A. A. S., the writer would be pleased to receive any further

suggestions from those interested, regarding the points noted above.

ROBT. B. WARDER.

HOWARD UNIVERSITY, WASHINGTON, D. C.

REMARKS ON SOME RECENT FUNGI EXSICCATI.

It is still a favorite mode among mycologists to distribute exsiccati, or series of specimens of fungi collected from time to time by various persons and in different localities. In times past these exsiccati have served a very useful end in enabling collectors to acquaint students with any new discoveries, and it has not been unusual to find many new species described in them. Even at the present day this habit prevails to a greater or less extent, and diagnoses of new species frequently occur in these collections. In the writer's mind, however; the custom, although sanctioned by long usage, is reprehensible, especially in those cases in which the species are not also described in some botanical journal. At a period when such journals were few, and when their circulation was limited, the distribution of exsiccati with these new species was justifiable; but now, with the great increase in means of publication and the facilities for illustration, the necessity for this has passed away. It is, indeed, questionable whether such species can be regarded as published in the strict sense of the word. Exsiccati are from their very nature ephemeral. They are easily destroyed by insects and other pests. They have no place on the shelves of the library. They are very limited in their circulation, and their limited numbers and relatively high price practically place them beyond the reach of the majority of students. Only a small number of persons, therefore, have access to them, and they must be sought for in the larger herbaria of the country. The majority of botanists are therefore seldom cognizant of the new species described in

these exsiccati. In many cases the specimens are distributed in the general herbarium as fast as they are received, and unless some record be kept of the new species they are soon lost to view in the great mass of specimens in the herbarium. The duplication of names has been a frequent result of this practice, and it is greatly to be desired that it cease. Let new species be described in regular standard publications, so that the majority rather than the minority of students will know of them.

Among the older distributions is that of Sydow, *Uredineæ*. This has now reached Fascicle XIX., Nos. 901-950. In this the genus *Puccinia* is the best represented, no less than 25 out of the 50 specimens belonging to it. Among them we note *P. simplex* (Körn.) Eriks. & Hen., which is a duplication of *P. simplex* Peck, 1881. (34th Ann. Rept. N. Y. State Mus. Nat. Hist., p. 45.) The old plan of writing the labels instead of printing them is pursued, to the great detriment of the appearance of the specimens and to the annoyance of those who attempt to decipher the names. We would recommend that a change be made in this regard.

The newer distribution of Jacewski, Komarov and Tranzschel, *Fungi Rossicæ*, has reached its second fascicle, Nos. 51-100. It is interesting in that it contains many specimens from little known or explored regions of eastern Russia and of Siberia. The specimens are neatly put up and have well printed labels.

Fascicle No. IX. of Seymour & Earle's *Economic Fungi* bears date of July 1, 1895, and consists of Nos. 401 to 450. It is made up of parasites on garden vegetables and fruit trees, and does not contain any special novelties unless it be the new hosts of *Plasmodiophora brassicæ* lately recorded by Halsted (Bull. Torr. Bot. Club, XXI., 76, 1894).

The latest arrivals are Fascicles IX. and X. of *Fungi Parasitici Scandinavici*, by

Eriksson. These come from the interesting region of northern Europe. They are accompanied by an index to the ten fascicles, in which are given the names, numbers and hosts of all the specimens distributed. Fascicle IX. (Nos. 401-450) is devoted entirely to the *Uredineæ*, all but two being species of *Puccinia*. *P. graminis* is represented by 19 specimens, several being given 'form' names. Two new species are described, viz., *P. pygmea* and *P. milii*. Fascicle X. (Nos. 451-500) is also largely devoted to *Uredineæ*, although some other orders are represented. Three new species are described. As it is believed that a useful purpose will be served by the publication of these descriptions they are given below from the original labels.

449. PUCCINIA PYGMEA Eriksson, n. sp.

Uredospore in soris minutis, oblongis, lineariter ordinatis, interdum confluentibus, aurantiacis, cum paraphysibus apice globoso-inflatis. Spore globosæ, 17-28 μ , aculeatæ. Paraphyses 48-80x11-16 μ . Teleutospore in soris minutis, oblongis, linearibus, tectis, atrofuscis, hypophyllis. Teleutospore clavate, apice explanatæ vel lateraliter apiculatæ, medio vix constrictæ, 35-42x11-14 μ .

Sueciæ in foliis Calamagrostis epigeei ad Borgholm, in portu, July 20, 1894.

450. PUCCINIA MILII Eriksson, n. sp.

Uredospore in soris oblongis solitariis vel lineariter ordinatis in maculis flavis foliorum, aurantiacis, cum paraphysibus apice globoso-inflatis. Spore globosæ, 19-24 μ aculeatæ. Paraphyses usque ad 64 μ . Teleutospore in soris aggregatis, oblongis, tectis, atrofuscis, hypophyllis. Teleutospore clavate, apice explanatæ, 27-41 μ longæ, cellula basalis 13-14 μ , terminalis 12-19 μ lata.

Sueciæ in foliis Milii effusi ad Experimentalåltet, (Sjöstugan), Stockholm, September 23, October 8, 1894.

494. ASCOCHYTA PUCCINIOPHYLLA Starback, n. sp.

Perithecia solitaria vel sæpissime 3-7 gregaria, hypophylla, maculis elevatis, pallide fuscidiis insidentia, epidermide elevato cincta, 100-120 μ diam. Sporule fusoides-lanceolatæ vel interdum oblongæ, diu continuæ, demum medioseptatæ, vix constrictæ utriusque appendiculis brevibus acutiusculis præditæ, 8-12x2-3 μ .

Intime intermixta crescit *Puccinia polygoni*.

Sueciz in foliis Polygoni amphibii in insulis lacus Glottern, par Quillinge Östergötland, August, 1891.

488. DIDYMARIA AQUATICA Starback, n. sp.

Maculæ varia forma, sæpissime suborbiculares, confluentes, amphigenæ e fusco griseæ, fuscomarginatæ. Hyphæ non manifestæ. Sporulæ rectæ, fusoidæ, utrinque obtusiusculæ, 10-19x4-5 μ .

Sueciz in foliis Alismatis plantaginis in lacu Glottern, Quillinge, Östergötland, August, 1891.

500. HETEROSPORIUM PROTEUS Starback, n. sp.

Cespitulæ hypophyllæ, laxæ gregariz in maculis aridis foliorum insidentes, hyphis fasciculatis, interdum ad basin conglutinatis stipiteque formantibus, compositæ. Hyphæ 95-100 μ long, 4.5 μ , 6.5 μ crassæ. Conidiæ e nodulis hypharum oriunda, et forman et magnitudine nem valde varia, cylindracea vel cylindracea-ellipsoidea, 3-septata 16-24x4.5-8 μ , 2-septata 14-15x6-7 μ , 1-septata 9-15x3-7.5 μ vel globosa, quæ rarissime adsunt, 5-6 diam., autem conspicuæ et densissime echinulata.

Heterosporio echinulato (Berk) Cooke affinis modis sporidiorum aliis notis exceptis, hæc species dignoscenda.

Sueciz in foliis Quercii sp. in Upsala, October, 1891.

JOSEPH F. JAMES.

THE BIBLIOGRAPHICA ZOOLOGICA AND ANATOMICA.

At the Baltimore meeting of the American Society of Naturalists (Dec. 1894) a committee was appointed to consider Dr. H. H. Field's plans for bibliographical reform, the committee to report in print. That committee would report as follows:

Dr. H. H. Field, in view of the well-known imperfections and shortcomings of all existing records of zoological literature, has formulated plans which will give the zoological world an approximately complete index of all current literature as promptly as possible. This record will be issued in the form of bulletins, each number of which will be distributed as soon as sufficient material has been accumulated to make a 'signature.' The same bulletin will also be issued printed only on one side of the page, to allow for cutting up for special bibliographies. Lastly, the separate titles

will be issued upon cards of the standard 'index' size. Each title will be followed by a few words giving the subject and scope of the article, when this is not sufficiently indicated by the title, while the cards will have, in addition, catch numbers, so that any library assistant can readily incorporate them in the card catalogue.

The plan contemplates a union of existing bibliographies with this one. In the case of the 'Naples Jahresbericht' this will be brought about by coöperation, the Naples series continuing practically as the yearly morphological analysis of the Bibliography. It is to be hoped that the 'Zoological Record' will consent to coöperate in a similar way, devoting itself to the systematic side, and by aid of the new facilities of coöperation increase its present usefulness to students. Arrangements have now progressed so far that it seems probable that the records of literature in the Zoologischer and Anatomischer Anzeigers will be merged in the new scheme, and it is hoped that the one in Archiv für Naturgeschichte will take the same course. If sufficient encouragement be given, it is proposed to include physiology in the scope of the new plan. The net gain will be fewer bibliographies, wider scope, nearer approximation to completeness, and more prompt publication.

The central office of the work will be established at Zürich, Switzerland, and it may be said that the cantonal government has already appropriated 2000 francs annually to its support, and will supply suitable quarters for its work. France has promised a similar sum, and aid is expected from Germany, from the International Congress of Zoologists and from the British Association for the Advancement of Science. Committees have been appointed in France, Germany and Russia to coöperate in making the record as complete as possible. Lastly, publishers stand ready to undertake the publication of the bulletins, cards, etc.,

without expense to the central office, since the sales are estimated to fully cover all cost of manufacture. The only matter unprovided for is that of preparing the Record for the printer, and this is already so far provided for that if America can contribute \$500.00, the beginning of the work with the year 1896 can be assured.

Your committee, having examined the matter in detail, would, therefore, report that they regard the plan as one worthy the fullest support of the American scientific world. They recommend it as worthy of financial support and would urge all publishers and publishing institutions to send all periodicals and other works (or in the case of books at least the correct title and a summary of contents prepared by the author) promptly to the central bureau. They would finally recommend the appointment of a permanent committee of ten to cooperate with similar committees in other countries in forwarding the movement.

(Signed) SAMUEL H. SCUDDER,
H. P. BOWDITCH,
HENRY F. OSBORN,
E. A. ANDREWS,
J. S. KINGSLEY,

Committee.

Since the above report was drawn up substantial progress has been made. The funds desired from America have been obtained: \$250 from the Elizabeth Thompson Fund, \$250 from the American Association for the Advancement of Science and \$50 from the American Society of Microscopists. Arrangements have been concluded for the publication of a '*Bibliographica Zoologica*,' as a continuation of the '*Litterateur*' of the *Zoölogischer Anzeiger*, and a '*Bibliographica Anatomica*,' to contain the morphological articles. The price of the *Bibliographica Zoologica* will be 15 Marks yearly. It will be published by Engelmann, of Leipzig. The price of the *Anatomica* has not been settled. Cards

containing the titles will be issued at from \$2.00 to \$3.00 a thousand, according to the number taken. Arrangements are now in progress for the inclusion of physiology in the plan, and steps have already been taken looking to the later incorporation of botanical literature.

CURRENT NOTES ON PHYSIOGRAPHY (XVIII.).

MACKINDER ON ENGLISH GEOGRAPHY.

THE address to the geographical section of the British Association last summer by Mackinder, reader in geography at Oxford, reviews the progress of the science in general, with especial reference to its advance in Germany. The still low position of geographical instruction in England is lamented, in contrast with its promotion on the Continent. There "some of the professors, as Richthofen, of Berlin, and Penck, of Vienna, have worked mainly at geomorphology; others, such as Krümmel, of Kiel, at oceanography; others, again, such as Ratzel, of Leipzig, at anthropography; while Wagner, of Göttingen, has been conspicuous in cartography, and Kirchhoff, of Halle, and Lehman, of Münster, in questions of method." In England, on the other hand, while an historical or classical student listens to a dozen different teachers at Oxford or Cambridge, a single lecturer at each university is charged with all geography. This wide subject has no appreciable position in degree examinations; there are no examinations at all for the post of secondary teacher, nor is there anywhere in the land anything really comparable to the German geographical institutes that form so important a part of the geographical equipment in certain universities.

The recognition of Mackinder's work in his election to preside over the geographical section of the Association is, however, an indication that even Englishmen are beginning to recognize that geographers, both explorers and teachers, need serious and

systematic training. In commenting on the proceedings of the geographical section, *Nature* says (October 3): "The characteristic of the meeting was the exceptionally scientific value of the papers, which dealt less with exploration than with research."

MOUNTAINS AND LOWLANDS OF GREECE.

PHILIPPSON continues his studies of classic ground (*Reisen und Forschungen in Nord-Griechenland, Zeitschr. Gesell. f. Erdk., Berlin, xxx, 1895, 135-225; geol. and topogr. maps*), telling of his journey along bad roads over half-barren mountain ridges, where the slopes are washed by intermittent torrents which carry gravel down to the valleys and bays. Settlements are chiefly found on the alluvial plains thus formed. Near the mountain foot the plains are stony and barren; further toward the sea the detritus is finer and fertile. This note suggests a reference, even if somewhat belated, to Philippson's work on Peloponnesus (*Berlin, Friedländer, 1892, 643 p., geol. and hypsom. maps*). The most striking physiographic features of Greece are there summarized; a varied relief of apparently confused changes from short ridges to deep depressions, from steep gorges to basin-like plains. This confusion results from the occurrence of complex zones of faulting in a previously folded mountain structure, producing a very diversified system of divides and water courses. There is no culminating range; no dominating divide, no extended valley trough; but, on the other hand, there is a large number of individual areas, not hermetically separated, but yet sharply divided (453-455). Many of the striking relations between form and history are pointed out. Geological structure, topography and climate are discussed with much care. The extraordinarily irregular coast, along which the sea penetrates far into the land, is due to a general depression of the region. The prevalence of 'potamogenous'

—river-formed—coast lines is shown to be dependent on the protected character of the shore, into whose quiet waters the steep torrents wash the waste from the mountains, building the land out into the sea.

W. M. DAVIS.

HARVARD UNIVERSITY.

SCIENTIFIC NOTES AND NEWS.

HARVARD COLLEGE OBSERVATORY.

It is announced by Prof. E. C. Pickering that for some years the need has been felt at the Harvard College Observatory of some means of making a more prompt announcement of the results of its work. It is proposed, therefore, to issue a series of circulars, as required, to announce any matters of interest, such as discoveries made, the results of recent observations, new plans of work, and gifts or bequests. It is not proposed to give these circulars a wide distribution, but rather to use them as a means of bringing new facts to the attention of the editors of astronomical and other periodicals, and thus secure the immediate publication of such portions as would be of interest to the readers of these periodicals. The distribution will be made without charge to such persons as will be likely to use the results.

THE first of these circulars, issued on October 30th, is on 'A New Star in Carina.' From an examination of the Draper Memorial photographs taken at the Arquipa Station of the Observatory, Mrs. Fleming has discovered that a new star appeared in the constellation Carina in the spring of 1895. A photograph, B 13027, taken on April 14, 1895, with an exposure of 60 minutes, shows a peculiar spectrum in which the hydrogen lines H_{β} , H_{γ} , H_{δ} , H_{ϵ} and H_{ζ} are bright, and the last four of these are accompanied by dark lines of slightly shorter wave-length. A conspicuous dark line also appears about midway between H_{γ} and H_{δ} . A comparison of the spectrum of this star

with that of Nova Aurigæ and Nova Normæ show that all three closely resemble each other and are apparently identical in their essential features. Another photograph taken on June 15th with an exposure of 60 minutes shows a change in the spectrum of this object. The hydrogen lines $H\beta$, $H\gamma$ and δ are still bright, although the continuous spectrum is very faint. Another line whose wave-length is about 4700 is here as bright as the hydrogen lines. On the photograph taken on April 14th it is barely visible.

An examination was next made of all the photographs of the region containing this star. On sixty-two plates, the first taken on May 17, 1889, and the last on March 5, 1895, no trace of the star is visible, although on some of them stars as faint as the fourteenth magnitude are clearly seen. The exposures of these plates varied from 10 to 242 minutes. On nine plates, the first taken on April 8th and the last on July 1, 1895, the star appears, and its photographic brightness diminishes during that time from the eighth to the eleventh magnitude. This star precedes A. G. C. 15269 (photometric magnitude 5.47) $0^m.5$, and is $0'.7$ north. Its approximate position for 1900 is therefore in R. A. $11^h3^m.9$, Dec. $-61^\circ 24'$. Two stars of the eleventh magnitude are near the Nova. One is nearly north, $110''$ distant, the other is $80''$ south preceding.

THE DEPARTMENT OF INSECTS OF THE U. S.
NATIONAL MUSEUM.

The staff of the Department of Insects of the U. S. National Museum has been reorganized as a result of the sad death of the former honorary curator, Professor C. V. Riley.

The reorganization has been effected by the appointment of Mr. L. O. Howard, entomologist of the U. S. Department of Agriculture, to the position of honorary

curator of the Department of Insects; of Mr. Wm. H. Ashmead to the position of custodian of Hymenoptera, and Mr. D. W. Coquillett to the position of custodian of Diptera. All museum custodians are honorary officers. Mr. M. L. Linell will remain as general assistant to the honorary curator.

The Department is at present in excellent working condition. It contains a very great amount of material in all orders, and in many unusual directions surpasses any collection in the country. Among others the following are of especial interest:—

1. The large collection, in all orders, of the late Dr. C. V. Riley.
2. All of the material gathered during the past 18 years by correspondents, field agents and the office staff of the division of entomology, U. S. Department of Agriculture.
3. The greater part of the collection of the late Asa Fitch.
4. The large collection, in all orders, of the late G. W. Belfrage.
5. The collections in Lepidoptera and Coleoptera made by Dr. John B. Smith down to 1889, together with the types of the Noctuidæ since described by Dr. Smith.
6. The collection of Lepidoptera of the late O. Meske.
7. The collection of Lepidoptera of G. Beyer.
8. The collection of Coleoptera of M. L. Linell.
9. The bulk of the collection, in all orders, of the late H. K. Morrison.
10. The collection of Diptera of the late Edward Burgess.
11. The type collection of Syrphidæ made by Dr. S. W. Williston.
12. The collection of Ixodidæ of the late Dr. George Marx.
13. The collection of Myriopoda of the late C. H. Bollman.
14. Sets of the neo-tropical collections of Herbert Smith.

15. The collection of Hymenoptera of Wm. J. Fox.

16. The collection of Tineina of Wm. Beutenmuller.

17. The large Japanese collection, in all orders, of Dr. K. Mitsukuri.

18. The African collections, in all orders, of Dr. W. S. Abbott, Wm. Astor Chanler, J. F. Brady, the last 'Eclipse' expedition to West Africa, and of several missionaries.

19. The large collection from South California of D. W. Coquillett, in Coleoptera, Hymenoptera, Lepidoptera and Orthoptera.

20. The Townend Glover manuscripts and plates.

In addition to this material, there are minor collections which have been the result of the work of government expeditions, or are gifts from United States Consuls and many private individuals.

This enormous mass of material is being cared for by the active and honorary force of the Department, and the perpetuity of the collection is assured. The National Museum building is fire-proof, and this, together with the fact that it is a National institution, renders the Department of Insects perhaps the best place in this country for the permanent deposit of types by working specialists in entomology, and for the ultimate resting-place of large collections made by individuals.

The policy of the Museum at large, with regard to the use of its collections by students, is a broad and liberal one. Students are welcome in all departments, and every facility is given to systematists of recognized standing.

THE THIRD INTERNATIONAL CONGRESS OF PSYCHOLOGY.

THE third meeting of the Congress will be held at Munich, in the Royal University, from August 4th to 7th, 1896, under the presidency of Professor Carl Stumpf, of

Berlin. Professor Lipps, of Munich, has been appointed vice-president and Dr. Frhr. von Schrenck-Notzing, secretary.

The list of members of the International Committee of Organization includes the names of well-known specialists in psychology from England, Scotland, France, Belgium, Germany, Switzerland, Russia, Italy, Denmark and the United States. The languages used at the Congress may be German, French, English and Italian. The length of papers to be presented before the Congress is limited to twenty minutes.

The program is divided into four parts, as follows: I. Psycho-physiology. II. Psychology of the Normal Individual. III. Psycho-pathology. IV. Comparative Psychology. The preliminary announcement of the Congress which has just been issued, and from which we have taken the above particulars, contains the following request which is worth verbatim quotation:

"Please propagate this program and publish it in all journals.

"Membres, who intent to lecture at this Congress are asked politely to announce their themes and to send extracts of them to the Secretary's office (Munich, Max-Joseph street 2) before the 15. of Mai 1896.

"For themes announced after the 15. of May the committee cannot pass its word for admittance. It is much to be recommended to give orders for lodgings in advance, because at the beginning of August the hotels of Munich are very much occupied.

"Arriving members of the Congress may inquire at the station after the bureau of the 'Verein zur Förderung des Fremdenverkehrs,' and they will willingly get all informations about hotels, pensions and privat lodgings to be well recommended.

"The Secretary's office is stationed from the 3. of August during the congress at the royal university (Ludwigstrasse 17)."

The subscription to the Congress is 15

Marks. The meetings are open not only to psychologists, but to all interested in the progress of psychology.

GENERAL.

A RECENT Bulletin (No. 119) of the U. S. Geological Survey by Mr. G. H. Eldridge describes the area in northwestern Wyoming that lies immediately south of Montana and some distance east of the Yellowstone National Park. It is occupied by the Wind River and Big Horn River basins, and is chiefly covered by the Wasatch and Bridger strata of the Eocene, by Cretaceous and Jura-Trias, with minor areas of Carboniferous, Silurian, Cambrian, Archean and eruptive rocks. The region has long been a fruitful source of Eocene vertebrate fossils, and in its northwestern portion is now an important center of coal mining, as it has rail connections. Mr. Eldridge gave these matters of mineral resources especial attention, and after a geological sketch, based on a colored map, he takes up the following topics: Coal, with numerous analyses and cross-sections, petroleum, building materials, gold, hot springs and agriculture. The bulletin extends our knowledge to an area about which little detailed information had been previously available.

DURING the past summer Dr. Leonhard Stejneger, while at Bering Island, was fortunate enough to secure some bones of Pallas' Cormorant at the locality where he had found others in 1882. At the time these were the only known bones of this extinct species. Among the more recently obtained specimens is a fairly complete cranium which is somewhat larger than that of any existing species, and is peculiar in the character of the ethmoid and opening in the front part of the cranium. Mr. Grebnitski has also procured some remains of Pallas' Cormorant from the same deposit.

THE Library Bureau of London has in-

augurated a Publishers' Central Showroom, to which most of the great English publishers will send all of their publications for inspection. To give the collection the character of a permanent exhibition and divest it of all the appearance of advertising, no books will be sold at the showroom and no orders taken.

PART 6 of Minnesota Botanical Studies is entirely given to Miss Josephine E. Tilden's Bibliography of American Algae. No less than 1,544 titles of papers are listed, although the work professes to be but a preliminary survey of the literature. This is one of the most complete and valuable pieces of special bibliographic work yet prepared for American botany.

IN addition to the teaching botanical garden of the University of Pennsylvania, which has recently been greatly improved and enlarged under the direction of Professor Macfarlane, the University will have the scientific management of Bertram's Gardens, which have recently been made one of the city's parks.

A MEETING of the directors of the Marine Biological Laboratory of Wood's Holl was held in Boston on November 7th. It was reported that the attendance during the past summer had been large and that there had been an increase in the number of the coöperating educational institutions. Gifts had been received by the treasurer during the year amounting to \$2,348. The laboratory is to a certain extent self-supporting, but subscriptions are needed for enlargements and to provide salaries for the officers and instructors.

IN a paper on 'The Stone Industry in 1894,' extracted from the recent report of the Director of the U. S. Geological Survey, Mr. W. C. Day passes in review the industries in granite, marble, slate, sandstone and limestone. An introductory discussion precedes each one, which affords both de-

scriptive and statistical information. The quarries are then taken up by States and much that is valuable for reference is placed in convenient and readily accessible form.

WE have received at this somewhat early date the number for January of a new semi-monthly medical journal *Pediatrics* published in New York and London, and edited by Dr. Geo. A. Carpenter, with an editorial staff including Professor A. Jacoby, of Columbia College, and other leading students of the diseases of children.

PROFESSOR L. L. DYCHE, of the University of Kansas, has returned from a six months' absence in the Arctic regions as a member of the Peary Relief Party. He has brought back to the University a valuable collection of skins and skeletons. With the exception of the musk-ox, Prof. Dyche has now personally secured a specimen of every known North American Arctic mammal.

SOME of the friends of the late Professor Sir Thomas Francis Wade propose to raise and offer to the University of Cambridge, a sum of money sufficient to provide for the construction of a catalogue of the large and important collection of Chinese literature which during his lifetime he presented to the University Library.

BRUSSELS is to be connected with the sea by a new canal, allowing vessels of 2,000 tons burden to reach the city, the estimated cost of which is 35,000,000 francs. The official name of the city will hereafter be 'Bruxelles Port de Mer.'

THE mortality from diphtheria in London has greatly increased recently. During the week ending October 19th the number of deaths was nearly double the average for the corresponding week of the ten preceding years 1885-94.

THE Carnegie Music Hall, Museum, Art Gallery and Free Library given by Mr. Andrew Carnegie to the city of Pittsburg,

was formally dedicated on November 5th. The gift of the building and library is accompanied by an endowment of \$1,000,000. Mr. Carnegie's gifts to the cities of Pittsburg, Allegheny, Braddock, Homestead and Duquesne amount to about \$4,000,000.

AT the request of State School Commissioner, John T. Glen, according to the Boston *Transcript*, Professor C. M. Strahan, of the State University, has drawn a map of Georgia, which shows the location and number of every common school (white and black), high school, college and university in the State. The map is twelve by ten feet and is the largest map of Georgia ever drawn.

THE annual meeting of the New Jersey Forestry Association was held in Lakewood on November 8th and 9th. A lecture was given by Dr. J. T. Rothrock on 'The Relation of Forests to the Surface of the Country,' and there were special discussions on the prevention of forest fires and the preservation of the Palisades.

THE Columbia University Press will publish shortly a life of the late President F. A. P. Barnard, prepared by John Fulton, of Philadelphia, at the request of Mrs. Barnard. The author had complete access to all Dr. Barnard's letters and papers, and traces his educational career in the South, as well as the development of Columbia College under his presidency.

A BRONZE bust, by Mr. D. W. Stevenson, of the distinguished botanist, Dr. Robert Brown, has been unveiled in his native town, Montrose, Forfarshire, Scotland. The bust is accompanied by a tablet bearing the inscription: "Robert Brown, D.C.L. Oxon, L.L.D. Edin., F.R.S. Lond., President of the Linnean Society, Member of the Institute of France. Born in this house 21st December, 1773; died in London 10th June, 1858. 'Botanicorum facile princeps.' Alex. von Humboldt."

THE death is announced in Usambara of Dr. Stapf, the geologist who, at the request of the German East Africa Company, proceeded a few months ago to East Africa in order to prospect for gold.

FATHER HURST, known for his contributions to archaeology, died recently in his 53d year.

THE death is announced of Prof. Herman Hellriegel, the well-known agriculturist, at the age of 63. Most of his researches were concerned with chemical and physiological questions relating to the nutrition of plants. His chief discovery, which was communicated to the agricultural chemistry section of the *Naturforscher Versammlung* in 1886, was the fixation of gaseous nitrogen by leguminous plants through the medium of their root nodules. Dr. Hellriegel was an honorary member of the Royal Agricultural Society of England, and a foreign associate of the *Société Nationale d'Agriculture* of Paris.

THE fifth centenary of the birth of Gutenberg will be celebrated in 1897 by the city of Mayence.

THE new session of the Royal Geographical Society will be opened on November 11th, when, after a short opening address by the President, Mr. A. Montefiore, will give an account of the progress of the Jackson-Harmsworth Expedition. At the second meeting Dr. K. Grossmann will give an account of the results of his recent visit to the Faeroe Islands, and at the December meeting the Rev. Walter Weston will describe his explorations in the Central Alps of Japan. All the papers will be fully illustrated by means of the lantern. After Christmas among other papers that may be expected are the following: 'Various Movements of the Earth's Crust,' by Professor John Milne, F. R. S.; 'British Central Africa, Its Geography and Resources,' by Mr. Alfred Sharpe; 'Exploration in the Alps of New Zealand,' by Mr. E. A. Fitz-

gerald; 'Our Knowledge of the Oceans,' by Dr. John Murray; 'The Geography of the English Lake District,' by Mr. J. E. Marr, F. R. S. It is hoped that Mr. and Mrs. Littledale will have returned from their adventurous journey across Central Asia before the end of the session and will give to the Society an account of their travels. The afternoon meetings in the map room, begun last session, will be resumed during the present session. Among the subjects to be brought forward for discussion will be: 'The Construction and Uses of Globes,' by Mr. J. Y. Buchanan, F. R. S.; 'The Struggle for Life in the North Polar Region,' by Mr. A. Trevor-Battye; 'An attempt to Reconstruct the Maps of Herodotus,' by J. L. Miers.

M. B. C., PERTH AMBOY, N. J., writes to the *New York Evening Post*, as follows:

"My mother—a sister of Gen. Meade—was born in Spain, and lived there until she was four years old, at which time her parents returned to this country and settled in Philadelphia. For some years Spanish was the only language spoken in the family; but when old enough my mother and her sisters were placed at Madame Ségoing's boarding school, which in the early part of the century was one of the most famous schools in the country. There she finished her education, and throughout her life had perfect control of the French language. The Spanish, however, she entirely forgot. My mother's last illness was tedious, her mind becoming gradually weakened; but long after she had ceased to speak English she would talk fluently in French. Then there came an interval towards the close of her life when she did not speak at all; but the last few words of all were—Spanish!" Cases have been previously reported in which a person in his last illness has used the long forgotten language of childhood, but the above case is of interest owing to the use of an intermediate language."

UNIVERSITY AND EDUCATIONAL NEWS.

MR. JOHN D. ROCKEFELLER has given an additional million dollars and a contingent contribution of two million dollars to the University of Chicago. His letter to the trustees is as follows:

OCTOBER 30, 1895.

To the Trustees of the University of Chicago, T. W. Goodspeed, D. D., Secretary:

GENTLEMEN: I will contribute to the University of Chicago \$1,000,000 for endowment, payable January 1, 1896, in cash, or at my option, in approved interest-bearing securities at their fair market value.

I will contribute in addition, \$2,000,000 for endowment or otherwise, as I may designate, payable in cash, or, at my option, in approved interest-bearing securities at their fair market value, but only in amounts equal to the contributions of others, in cash or its equivalent not hitherto promised, as the same shall be received by the university. This pledge shall be void as to any portion of the sum herein promised, which shall prove not to be payable on the above terms, on or before January 1, 1900.

Yours very truly,

(Signed) JOHN D. ROCKEFELLER.

These gifts will make the entire amount of Mr. Rockefeller's donations to the University of Chicago about \$7,600,000, probably the largest gift ever made by an individual for educational or public purposes.

PROFESSOR GEORGE W. SMITH was to have been installed as President of Colgate University on November 14th. President Gilman was to deliver the principal address, and other prominent educators signified their intention of being present.

THE University of Minnesota has five new buildings nearly completed. They are (1) Medical Laboratories (\$40,000); (2) Armory (\$100,000); (3) Dairy Laboratories (\$30,000); (4) Dining Hall and Dormitory for School of Agriculture (\$30,000) and (5) Astronomical Observatory (\$10,000). The new die-testing works (\$25,000) are this year opened for experimental work.

THE University of Kansas began its thirtieth year September 5th. Owing to the absence of Chancellor F. H. Snow the

formal opening exercises were postponed until October 4th. On that date James Willis Gleed delivered the opening address. The University year opens with an enrollment of 725 students, divided among the five schools of which the University is composed as follows: Arts, 420; Law, 101; Pharmacy, 58; Engineering, 86, and Fine Arts, 63. This is an increase of a hundred over last year.

THE new Physics and Electrical Engineering building of the University of Kansas, finished during the summer, is now occupied by the physics department. This building has been erected by the State, and is designed for physical work and especially for research in electricity. The head of this department is Dr. Lucien I. Blake, best known by reason of his experiments for the United States government in establishing telephonic communication between the light ships of the Atlantic coast and the adjacent shores. W. N. Whitten, University of Michigan, '95, has been elected assistant in the chemical laboratories during the absence of E. H. S. Bailey, head of the department. Prof. Bailey has been granted leave of absence for study in Europe during the fall term. Owing to the crowded conditions of the chemical laboratories it has been necessary to fit up additional desks in the main building, to which all work in organic chemistry will be transferred.

PROFESSOR EDWARD GRANT CONKLIN, of the Northwestern University, of Evanston, Ill., has been elected professor of comparative embryology in the University of Pennsylvania, in place of the late Dr. John Ryder. Dr. Harrison Allen, who recently resigned the directorship of the Wistar Museum, has been made emeritus professor of comparative anatomy.

THE committee engaged in raising funds for the Women's College, in connection with Brown University, have raised \$20,-

000 of the \$50,000 required for the erection of a building.

MR. ANDREW CARNEGIE has given Williams College \$900 to free the infirmary from debt.

EDWARD PIÉRCÉ, PH. D. (Harvard), has been appointed instructor in psychology in the University of Michigan.

V. L. LEIGHTON, last year assistant in the chemical laboratory of the University of Kansas, has been called to a similar position in Tufts College, Mass.

THE annual meeting of the New England colleges was held at Hanover, N. H., (Dartmouth College) on November 7th and 8th. The institutions represented by delegates, including in nearly all cases the presidents, were Harvard, Yale, Brown, Williams, Amherst, Trinity, Wesleyan, Tufts, Boston, Bowdoin, Clark, Vermont and Dartmouth.

AN association of colleges and academies of the Southern States was formed at Atlanta on November 7th, representing fourteen institutions.

THE friends of Mrs. Agassiz have contributed \$6,000 to Radcliffe College to be used for the establishment of an Elizabeth Cary Agassiz Scholarship.

DR. GALLE, professor of astronomy at the University of Breslau and director of the observatory, has resigned.

DR. KLINGER, professor of chemistry at the University at Bonn, has received a call to the University of Königsberg.

THE electrical and anatomical institutes founded by M. Ernest Solvay and presented by him and other donors to the University of Brussels, were officially inaugurated on October 30, under the Presidency of the Burgomaster, assisted by M. Graux, the Chancellor, and the entire body of professors. Delegations from the English and Continental universities responded to the

invitation of the Brussels University to take part in the series of *fêtes* organized in celebration of the event.

DISCUSSION AND CORRESPONDENCE.

THE INTERNATIONAL CODE OF NOMENCLATURE.

UPON reading the statement that the *Third International Zoölogical Congress* has appointed an International Commission of five members to study the different codes of nomenclature proposed and adopted in various countries, some zoölogists may immediately draw the conclusion that it is the intention to overturn (or rather to attempt to overturn!) existing and well established practices in nomenclature. One or two persons with whom I have talked upon the subject did, in fact, have this impression. In order to dispel such thoughts from any and all minds in which they may arise, I desire to state definitely that no such plan was contemplated by Geheirnath Schulze (Berlin) when he made his proposition, nor by the Congress when the proposition was adopted. Furthermore, from what I know personally of the men on the Commission, it can be positively stated that such an idea is very far from their thoughts.

Every one will admit that there are points in the International Code upon which differences of opinion exist; that different interpretations of the code have been made in various countries; that the *arrangement* of the code has been criticized in some quarters; that some of the translations of the code have not been all that could be desired in the way of exactness; and that in various countries differences of opinion exist upon some points which are not included in the present international code.

The objects Prof. Schulze had in making his proposition were to submit all of these points to investigation by an international committee; to have an authorized edition of the code in English, French and German; to add points which had been omitted; to better the code where this can be done; and to embody the results of this study in a report to be presented to the next International Congress.

I would further call attention to the fact that the report of this commission is not final, but

is subject to the action of the next International Congress, to be held in Great Britain in 1898.

A large edition of the International Code has been issued by the Société Zoologique de France for general distribution; and any working zoölogist may obtain a copy of it by addressing the Secretary, Prof. Raphael Blanchard, 32 rue du Luxembourg, Paris, France.

Should any American zoölogist have any suggestions to be made in regard to additions, amendments, etc., to this Code I request him to communicate with me before September 1, 1896.

There are a few points in this Code with which perhaps the majority of American zoölogists are not in sympathy. 'The majority of American zoölogists,' however, does not mean 'the majority of the zoölogists of the world,' and while it is beyond question that a view expressed by the majority of workers in this country will receive the utmost consideration, we must not forget that the next International Congress cannot be expected to repeal the present International Code and adopt an American, French, German or English Code in its place, but must stand by international decision upon all questions in regard to which differences of opinion exist.

It is my intention to request the National Academy, The Smithsonian Institution, the Society of American Naturalists, the American Ornithologists' Union, the American Association for the Advancement of Science and the Royal Society of Canada, each to appoint one of its members as a representative upon an Advisory Committee to which I may submit for approval or disapproval all of the questions which I intend to support in the meetings of the International Commission, and with which I may advise regarding concessions to be made or requested in those points upon which American opinion differs from the views held in some of the other countries. It is needless to add that my vote in the International Commission will be determined by the action of this Advisory Committee, should the occasion arise that my personal opinion upon any particular point differs from the opinion of the gentlemen appointed to advise me.

CH. WARDELL STILES,

B. A. I., U. S. Dept. Agriculture.

WASHINGTON, D. C.

KATYDID ORCHESTRATION.

TO THE EDITOR OF SCIENCE: I am interested in the notes lately published in SCIENCE on this subject, and should be very glad to have the insect described by Mr. Gould identified, for my own information. This is because, during two summers spent at Cranberry, in the mountains of North Carolina, not far from Roan Mountain, I continually heard the same music Mr. Gould describes, and have no doubt that my insect and his are the same. Supposing it to be, of course, well known to entomologists, I preserved no specimens, and only remember being struck by the very small size of those I handled. It is certainly not the common Katydid, *Cyrtophyllum concavum*. Aside from the almost deafening noise which seemed, as it were, to make the trees tremble, what struck me most was the punctuality with which the orchestra tuned up at a particular time near sunset, the regularity with which the performance continued through the night, and its conclusion at a certain hour in the morning. The inhabitants of the place also speak of the seasonal periodicity of this insect, which is so perfect that they draw certain weather prophecies from its acceleration or retardation of two or three days.

ELLIOTT COUES.

WASHINGTON, 1726 Street.

November 2, 1895.

TO THE EDITOR OF SCIENCE: The antiphonal rhythm of two 'orchestras' of Katydid is so very familiar to me that I was rather surprised to read of it in Dr. Gould's letter of September 20, supposing, as I did, that what I regarded as such an ordinary occurrence must, of course, have been noted and explained by entomologists. But the letters of Prof. Smith and Mr. Scudder in your issue of November 1st imply that such is not the case. My testimony, therefore, may be of some interest. Dr. Gould's description fits exactly the phenomena noticed evening after evening at my home in Montclair, N. J. The 'antiphony' is often very regular for several minutes, sometimes stopping short and again becoming broken into irregular individual stridulation at the end. I have sometimes thought that the exact unison of movement

might be purely mechanical and analogous to the control of one vibrating body by another, the medium of control in this case being the sensitiveness of one insect to the stridulations of another. But the fact that they often start all at once seems to bar out this hypothesis, and, indeed, is a fact difficult to account for in any way.

As to the pitch, it certainly seems as if one 'orchestra' were from a semitone to a tone removed from the other, but, as Mr. Scudder suggests, this may be only apparent. In case it is real, however, may it not be due to the falling into beat of each insect with those to whose stridulation it is most sensitive—namely, those that produce sounds approximating to its own in pitch?

ARTHUR P. BOSTWICK.

NEW YORK, November 5th.

THE SCIENCE OF MENTATION.

EDITOR OF SCIENCE: Some time since a reference was made in SCIENCE to a paper published with the above title in the *Monist* for July. The author was reported to have studied by experimental methods the development of certain forms of mentation in dogs. As I have been greatly interested in the subject of comparative psychology for years, and have myself been devoting much time to the study of the psychic development of animals from birth onward with investigation of the contemporaneous changes of a physical kind especially in the brain, I looked up the article referred to, written by Mr. Elmer Gates. Many of the statements and conclusions are of so remarkable a character that I should be glad to get further information, as would, no doubt, others also. We are told that seven shepherd puppies were confined in a completely darkened room for nine months; that the mother was permitted to go in and out; but we are not informed as to whether the mother was admitted for the sole purpose of suckling the puppies, though this is the natural inference. Now, if a dam is capable of supplying seven puppies at nine months of age with all the nourishment they require, as one specially interested in dogs and who has for years made a special study of these animals and bred them extensively, I should like to know the facts; for nothing of like kind is, so far as I am

aware, on record, and on the face of it I should doubt the possibility of such a thing. I see no necessity for any such drain on the dam, yet Mr. Gate's paper leaves the matter in doubt.

Again, though the most sweeping conclusions are drawn as results both positive and negative, following functional use and disuse, of certain portions of the organism, and though these experiments stand almost or quite alone, but meagre details are given either of the experiments or the anatomical appearances, and not a single illustration either diagrammatic or other accompanies the paper, nor is there any intimation that such details or illustrations have been or are to be published elsewhere. I should like to point out that such work is of but little use to scientific men in its present form, for at best it is only suggestive, not demonstrative. It is to be hoped that if Mr. Elmer Gates can furnish the details and illustrations necessary to meet scientific requirements he will lose no time in doing so, as, if his experiments, etc., are probable and his conclusions correct, they are not only of great scientific interest but of much practical importance to educationists and others. Mr. Gates' paper abounds in very stimulating 'mentation,' and much of it seems to fit very naturally into my own mental moulds. In asking for more details I think that I am writing in the interests of a large class of scientists and others.

WESLEY MILLS.

PHYSIOLOGICAL LABORATORY,
MCGILL UNIVERSITY, MONTREAL.

INVERTED IMAGE ONCE MORE.

IF Prof. Woodworth (see SCIENCE, October 25, p. 555) will look into my little volume on *Sight*, pp. 87 and 88, he will find described and explained not only the phenomena he refers to, but all his experiments with the lids. I have been familiar with the phenomena all my life, but first described and explained it in 1871 (see *Phil. Mag.*, Vol. LXI., p. 266, 1871). I afterwards discovered that it had been previously explained by Priestley. It is not due to imperfect accommodation, as Prof. Cattell thinks, but to *refraction by the concave watery meniscus between the two lids and the surface of the cornea*. The following figure will explain itself and the phenomena in question. The central ray c^1



from a candle passes straight to the retina as usual and forms the image on the central spot of the retina, but the upper marginal rays *a* are refracted upward to *b'* on the retina and the lower marginal rays *b* to *a'*. These are referred back by the law of direction as shown by the dotted lines.

JOSEPH LE CONTE.

BERKELEY, October 30th, 1895.

Professor Le Conte describes one of the imperfections in the dioptric apparatus which lead to the formation of entoptic rays of light. In my note to which he refers I only noticed the inversion of the image, and did not attempt to describe the various defects which cause the dispersion of light, only saying, in agreement with Professor Le Conte, that "the light from a gasjet passing through the lower half of the pupil is in part refracted downward, affects the lower half of the retina, and is projected as rays extending upward." Professor Le Conte's explanation accounts for the vertical dispersal of light when the eyelids are partly closed, but there are other defects in accommodation which lead us to represent a 'star' not by \cdot but by $*$.

I almost hesitate to refer again to the inverted image on the retina. The phenomenon is explained so clearly by Berkeley in his *New Theory of Vision* that it ought not to have been regarded as a puzzle since 1709. What Professor Le Conte has written on the subject in his suggestive and valuable book on *Sight* and recently in this JOURNAL (p. 629 of this volume) seems to me beside the mark. Our notions of up and down come from sensations of touch and movement. A visual image can only be erect or inverted in reference to other visual images—not in reference to entirely disparate sensations of touch and movement. The image of a man on the retina has the feet towards the image of the ground, and this is what we mean by being erect. The retinal image is in any case

only a link in a chain of physical processes. We do not know how the nerve fibres from the retina are distributed in the brain, but it is highly improbable that they end in a surface or reconstruct in any way a picture or a model of the external world.

J. MCKEEN CATTELL.

SCIENTIFIC LITERATURE.

British Association for the Advancement of Science (Ipswich, 1895). Tenth Report on the North-western Tribes of Canada. Fifth Report on the Indians of British Columbia. By FRANZ BOAS. 71 pp. 8vo.

This final report of Dr. Boas concludes the investigations, initiated in 1884, which have added so much to our knowledge of the social condition, mental and physical characteristics, languages and institutions of the northwestern tribes of the Dominion of Canada. The main portion of the report is concerned with an account, excellent in detail of presentation, of the 'Physical Characteristics of the Tribes of the North Pacific coast (pages 3-30, besides 11 tables of anthropometric data, and many lesser tables in the text)', we have besides notes on the Tinneh tribe of Portland Canal, the Tinneh tribe of Nicola Valley, the Nass River, and brief accounts of the Niská (closely related to Tsimshian), and the Ts' E'ts' á ú (a Tinneh dialect).

The value and extent of Dr. Boas' contributions to the physical anthropology of the Indians of the northwest coast may be estimated from the fact that the eleven tables alone contain the individual measurement (12 in each case) of some 500 Indians belonging to about a dozen tribes, or subtribes, and to several distinct linguistic stocks. The author's chief conclusions as to physical characteristics are as follows:

1. There is a gradual decrease in stature as we go southward along the coast from Alaska to Frazer River—the Tlingit averaging 173 cm., the Indians on the shore of Harrison Lake only 158 cm. As we go southward the stature increases again, but its distribution becomes very irregular. Somewhere between Vancouver Island and the Skeena River a very material change of type takes place. Dr. Boas shows

clearly the uniformity of the Kwakiutl group of tribes, and incidentally notes that it is clearly shown that "a strong deformation of the kind practiced by the Kwakiutl increases the length of head and diminishes the breadth of head; but moderate degrees of deformation do not influence materially the lower portion of the skull in which the greatest width of the head is found." The dimensions of the face seem uninfluenced also.

2. This distribution of stature Dr. Boas considers as being incapable of being explained by difference of food supply or mode of life, but is due to 'a slow permeation of the tall tribes of the North and of the short tribes of Fraser River.'

3. From the study of the British Columbian tribes, as well as from his general survey of the Indians of the whole of North America, the author finds that the "proportionate difference between the stature of men and women is the less the smaller the people," and that "the women of the short tribes of the Pacific coast seem to be taller than those of the short tribes of other regions."

4. Four types must be distinguished on the coast of British Columbia: (1) Nass River Indian type; (2) Kwakiutl type; (3) type of Harrison Lake and Salish of the interior; (4) type of the Okanagan, Flathead and Shuswap. The Nass River Indians have a face "the breadth of which (156.5) may be called enormous, as it exceeds the average breadth of face of the North American Indian by 6 mm." The face of the Kwakiutl is marked by its enormous height; while the nose is characteristic. The Harrison Lake Indians have "a head exceedingly short and broad, surpassing in this respect all other forms known to exist in North America." The head of the Shuswap is "shorter than that of the tribes of northern British Columbia, or of the Indians of the Plains." Dr. Boas justly remarks the difficulty in comparing descriptive features, "on account of the large personal equation of the observers, and even of the same observer at different times."

5. Among the tribes, of Fraser River "children seem to be much more brachycephalic than adults." The author remarks, however: "Investigations carried on by means of exten-

sive material do not show any such differences, and it is likely that more extended investigations would cause the apparent difference to disappear; but it is also possible that in this region we may find the length of head to increase more rapidly than the breadth of head. Among the Eastern Indians, and in different parts of Europe, we find a slight decrease of the cephalic index with increasing age, but in no case does the difference exceed one per cent. We also find that the heads of women are somewhat shorter than those of men."

6. "The cephalic index decreases rapidly as we go up Fraser River, but is higher among the Shuswap than among the Nkamtcinemuq. The facial index increases quite regularly from Harrison Lake to the Shuswap, but we must remember that the face of the Ntlakyāpamuq'ō'e is much smaller than that of the Shuswap and that of the lower divisions of the Ntlakyā'pamuq. The nasal index is so variable that we cannot draw any conclusions from its average values."

7. The Ntlakyā'pamuq'ō'e, while speaking one language, offer "an excellent example of the fact that linguistic and anatomical classifications do not follow the same lines"—being a people of mixed blood.

A very interesting section of the report is that which deals with the average number of children per mother among certain of the British Columbian tribes—the Kwakiutl especially. Of the latter Dr. Boas says: "The maximum sterility is found among women who are now from forty to fifty years old, that is who became mature about twenty-five or thirty years ago. This agrees very closely with the time when the Kwakiutl sent their women most extensively to Victoria for purposes of prostitution. During the last decade a number of influential men among the tribe have set their influence against this practice, and we see at the same time a rapid increase in the number of children. The young women who have now an average number of 2.7 children, may hope to regain the number of children which their grandmothers had. But the only hope of preserving the life of the tribe lies in the most rigid suppression of these visits of women to Victoria, which are still continued to a considerable extent, and in an effort to stamp

out the diseases which have been caused by these visits."

Pages 30-34 are taken up with notes on the Tinneh tribe of Nicola Valley, now extinct, whose language Dr. Boas shows "was much more closely related to the Tinneh languages of British Columbia than to those farther south, although it would seem to have differed from the former also considerably." A noteworthy addition to our knowledge of British Columbian peoples is the sketch of the Ts'ets'á'ut, first scientifically studied by Dr. Boas (pp. 34-48) and of the Niská (pp. 49-62), details of whose sociology and folk-lore, etc., are given. The linguistics of the report (pp. 62-71), though not extensive, are new and valuable. Taken all together this excellent report fitly crowns the work of the committee under whose auspices these investigations were inaugurated. It is sincerely to be hoped that some way will be found to continue researches that have been productive of such great results and added so much to American anthropology and linguistics.

ALEX. F. CHAMBERLAIN.

Solution and Electrolysis. By W. C. D. WET-
HAM, M. A. Macmillan & Co., London and
New York. Price \$1.90.

This book forms one of the physical series of the Cambridge Natural Science Manuals. It gives a summary of the work which has been done up to the present time, but particularly during the last twenty years, on the physical properties of solutions. This subject forms a branch of physical chemistry which has, within the last few years, attracted towards it a number of eminent investigators, who have obtained results of great interest and importance. To the student of the properties of matter it is difficult to conceive of any more fascinating branch of study than that of diffusion, osmotic pressure, the influence of dissolved substances on the freezing point, boiling point and vapor pressure of solvents, and the very curious difference between electrolytic and non-electrolytic solutions. The subject is only beginning to crystallize and few systematic treatises, and these mostly German, are devoted to it. The present work will therefore be welcomed by readers who prefer works written in the English language. It gives

in brief form an account of the results so far arrived at and the theories towards which they point. This summary will no doubt prove of great service to students and also to physicists and chemists who have not followed the investigations in the publications of scientific societies and the journals.

The treatment of the subject is perhaps rather too brief, but outside of that the presentation of the subject is good and the printing is, as usual, very satisfactory. A few instances of somewhat careless statement exist as, for instance, the statement of the thermodynamic cycle on p. 26, which is incomplete. This is unfortunate, because everything with regard to the second law of thermodynamics seems to be a source of difficulty to students. Again, the references are occasionally misleading. Take, for example, that to Jahn's work on the Peltier effect given on p. 117. Most students would interpret it to mean that the idea of testing contact difference of potential through Peltier's effect originated with Jahn, whereas it has been in the minds of physicists and has given rise to discussion for forty years or more.

The paragraph on p. 204 on the explanation of the possible effect of specific inductive capacity on ionization power seems unsatisfactory. To any one who requires an explanation that given is probably useless.

Fitzpatrick's tables on the 'electro-chemical properties of solutions,' originally printed in the British Association proceedings, are given in an appendix and will no doubt be welcomed by many.

The book is well worth perusal and is a valuable addition to our works on physics and chemistry.

THOMAS GRAY.

Critical Periods in the History of the Earth. By JOSEPH LE CONTE. Bulletin Dept. Geology, University of California. Vol. I., No. 11, pp. 313-336. Berkeley, August, 1895. (Reprinted.)

This is, in a somewhat condensed form, the address which opened the discussion, by the Congress of Geologists at Chicago, August, 1893, on the question "Are there any natural divisions of the geological record which are of world-wide extent?" The author begins with a brief refer-

ence to the cataclysmic and supernatural origin ideas of the early geologists and with tributes to Lyell and Darwin as the exponents of uniformitarianism and evolution. The present status of thought is defined to be 'that of gradual evolution both of the earth and of organic forms, but *not at a uniform rate.*' In other words, we now recognize that the laws and forces of nature work not as along a rigid line but so that the effects are cyclical, and the questions to be solved are how far the changes produced, or some of them have been general, instead of local, and may they or any of them be used to determine the division or subdivision of geological history for the whole earth? The adaptation of the European standards of classification were found difficult or impossible for other parts of the world, which led to the idea, against which the author raises a warning voice, that *all* changes are local. The author claims that there have been 'critical periods' in the earth's history—physical changes so great as to affect the climates of the earth as a whole and to cause marked changes in organic forms. The physical changes compel organic changes largely by inducing or compelling migration of species, thus bringing about new environments and new struggles for existence between faunas and floras.

Amongst the signs of such critical periods are mentioned widespread unconformities; sudden changes in organic forms, affecting not only species but sometimes genera and families; the introduction of new and higher dominant classes; the birth of great mountain ranges. Of these the most general and important are considered to be represented by changes in organic forms. This is, therefore, adopted for determining the primary divisions of geologic time. Secondary divisions are based on less general changes and are more local in their application.

Even the greatest changes are not to be considered as catastrophic. They were not instantaneous or simultaneous, but probably extended through hundreds of thousands of years and were propagated gradually from place to place.

Four such critical periods or revolutions are mentioned. I. The Glacial, in which the physical cause was the great change in climate and

the attendant oscillations of level, leading to wide migrations and extinctions of organic forms and the appearance of man. II. The Post-Cretaceous, or Rocky Mountain, which resulted in the obliteration of the interior cretaceous sea and the unification of the American continent, during which mammalian life was evolved, and of which the Laramie may be considered as the transition period. III. The Post-Palæozoic, or Appalachian, of which the Permian may be considered the transition period, and which brought about the greatest change in life-forms that is recorded in geologic history. Amongst the physical changes which brought these about are mentioned the evident *oscillations* of temperature, including even well defined and extensive periods of glaciation. IV. The Pre-Cambrian. This is marked principally in the rock system by universal unconformity, as the life system was such an inconspicuous element in those early times.

We should therefore have practically the divisions as now recognized, beginning with the earliest. Eozoic, up to the Cambrian period; Paleozoic, up to the Triassic, with the Permian as a transition epoch; Mesozoic, up to the Tertiary, with the Laramie as a transition epoch; Neozoic, up to the advent of the Ice age, and finally all time from them to the present.

The author notes that these critical periods have become gradually shorter and shorter, the changes in physical geography less and less, and in consequence the changes in organic forms less and less. The shortest in duration, the least in geographical changes, and the least complete and sweeping in changes of organic forms is the last; but the effect of the introduction of new dominant types in producing changes has been steadily increasing, as witness the appearance of man. Also the oscillations of temperature at critical periods have increased with time.

The subject closes with a discussion of the laws of evolution of the organic world and the suddenness of changes and variety of transitional forms. As a type in this latter connection is quoted the change which occurred between Paleozoic and Mesozoic times, which is accounted for partly by loss of the record and

partly by probable exceptional rapidity of evolution, the more rapid extinction of old forms and the comparative paucity of newly evolved forms, hence the poverty of fossils.

In a brief review of a confessedly concentrated dissertation it is not possible to do more than merely outline its scope. The paper is one of the principal importance of which lies in the significance of its hints rather than in its finished conclusions.

ARTHUR HOLLICK.

The Practice of Massage: Its Physiological Effects and Therapeutic Uses. By A. SYMONS ECCLES, M. B. ABERD., M. R. C. S., England. London, Macmillan & Co. 1895. 8vo. Price \$2.50.

It is evident at a glance that the author is a man who can see and think as well as rub. He deals largely with the philosophy of massage and presents his observations in a very plain and comprehensive manner. The book is not a manual for the manipulator so much as a physiological treatise suggesting to the reader the wide scope for the employment of massage and the precise manner in which it acts in given cases.

The text is enriched by ample references to the best and latest literature in which full credit is given to American authors. Among other affections massage is strongly advocated for the treatment of "Golf-hip" an accident which the author was the first to describe. It is a condition of gluteal strain occurring as the result of over-vigorous employment of the 'driving stroke,' and perhaps associated with a lack of skill in neophytes. One of Mr. Eccles' patients had within ten days of his accident been learning to play golf and had devoted the greater part of an afternoon to the practice of a stroke involving an attitude and a rapid muscular effort; desiring to pose, while driving a 'tee'd ball,' in the most finished style, he felt a violent pain in the upper and outer part of the buttock and over the right lumbar region, so that on leaving the ground he was unable to walk without much suffering and could not stand erect. Massage cured him, as it will sufferers from a sprained ankle, the lawn tennis elbow and similar accidents. The author claims that massage is a great but neglected

adjuvant in the treatment of fractures but he goes too far when he says: "Excellent results have been obtained without muscular atrophy in fractures of the patella and leg bones, locomotion without support, save from a stick, being acquired in a fortnight."

In applying massage in medical cases, on the other hand, he wisely says that "Impatience is the stumbling-block most readily impeding recovery, and unless this can be curbed success will not attend the methods advocated." "Unfortunately no method of treatment can be vaunted as a cure for deficiency of moral courage." Massage, however, is a great help in the treatment of the morphia and alcohol habits. It is also advocated by the writer for the 'strychnia habit,' a condition not observed, so far as we know, in America.

As Great Britain has signified her acceptance of the metric system, we hope that future editions of this valuable work will discard the use of 'stones,' with pounds in favor of something more intelligible for readers the world over.

GUY HINSDALE.

NEW BOOKS.

Neue Versuche zum Saison — Dimorphismus der Schmetterlinge. AUGUST WEISMANN. Jena, Gustav Fischer. 1895. Pp. 74. M. 1.50.

Neue Gedanken zur Vererbungsfrage eine Antwort an Herbert Spencer. AUGUST WEISMANN. Jena, Gustav Fischer. 1895. Pp. 72. M. 1.50.

Anleitung zur Mikrochemischen Analyse. H. BEHRENS. Hamburg and Leipzig, Leopold Voss. 1895. Pp. viii + 64.

Elektricität und Licht. O. LEHMANN. Braunschweig, Vieweg und Sohn. 1895. Pp. xv. + 390. M. 7.00.

Atlas d'Ostéologie. CH. DEBIERRE. Paris, Félix Alean. 1895. Pp. viii + 92. 12 fr.

Missouri Geological Survey. Vol. III. CHARLES R. KEYES. Jefferson City. 1895. Pp. 405.

Anarchy or Government. WILLIAM MACKINTIRE SALLER. New York & Boston, Thomas T. Crowell & Co. Pp. viii + 177. 75 cents.

Eliodorpha, The End of the Earth. JOHN URI LLOYD. Pp. 376.

SCIENCE

NEW SERIES.
VOL. II. NO. 46

FRIDAY, NOVEMBER 15, 1895.

SINGLE COPIES, 15 CTS.
ANNUAL SUBSCRIPTION, \$5.00.

GUSTAV E. STECHERT'S

Recent Importation of Scientific Books.

ADICKES, DR. ERICH. Kant-Studien. 185 Seiten. gr. 8^o. Mk. 4⁰⁰.

BENEDIKT, DR. MOR. Die Seelenkunde des Menschen als reine Erfahrungswissenschaft. 372 Seiten. 8^o. Mk. 6⁰⁰.

BERMBACH, DR. W. Der elektrische Strom und seine wichtigsten Anwendungen in gemeinverständlicher Darstellung. Mit 90 Abbildungen. 108 Seiten. 8^o. Mk. 2⁰⁰.

BIEDERMANN, W. Elektrophysiologie. 1^{te} Abtheilung. Mit 136 Abbildungen. 440 Seiten. 8^o. Mk. 9.

BOEGLE, DR. C. Die Entstehung organischer Formen. 18 Seiten. 8^o. Mk. 1²⁰.

CAPTAINNE, EMIL. Das Wesen des Erfindens. Eine Erklärung der schöpferischen Geistesthätigkeit an Beispielen planmäßiger Aufstellung u. Lösung erfinderischer Aufgaben. 135 Seiten. 8^o. Mk. 3⁰⁰.

DELAGE, YVES. La structure du protoplasma et les théories sur l'hérédité et les grands problèmes de la biologie générale. 878 pages. gr. 8^o cloth. frs 24⁰⁰.

DÜHRING, DR. E. Wirklichkeitsphilosophie, Phantasmenfreie Naturergründung und gerecht freie liche Lebensordnung. 554 Seiten. 8^o. Mk. 9⁰⁰.

FOREL, DR. AUGUST. Der Hypnotismus, seine psycho-psysiologische medicinische, strafrechtliche Bedeutung und seine Handhabung. 3^{te} verb. Aufl. mit Adnotationen von Dr. O. Vogt. 223 Seiten. gr. 8^o. Mk. 5.

FRICKS, DR. J. Physikalische Technik speciell-Anleitung zur Ausführung physikalischer Demonstrationen und zur Herstellung von physikalischen Demonstrations-Apparaten mit mögl. einfachen Mitteln. 6^{te} umgearb. und verm. Aufl. von Dr. Otto Lehmann. II. Band. Illustriert. 1054 Seiten. gr. 8^o. Mk. 20⁰⁰.

GRIESBACH, PROF. DR. H. Physicalisch-Chemische Propädeutik unter besonderer Berücksichtigung der medicin. Wissenschaften u. mit histor. und biographischen Angaben. 1^{te} Hälfte. Bogen 1-17 mit Figur 1-44. gr. 8^o. Mk. 5⁰⁰.

HAACKE, DR. WILH. Die Schöpfung des Menschen und seiner Ideale. Ein Versuch zur Versöhnung zwischen Religion und Wissenschaft. Mit 62 Abbildungen im Text. 487 Seiten. gr. 8^o. Mk. 12⁰⁰.

HAMPE, DR. JULIUS. Ueber Geisteskrankheiten in Folge Schwefelkohlenstoff-Vergiftung. 51 Seiten. 8^o. Mk. 1⁰⁰.

HANSEN, DR. EMIL CHR. Untersuchungen aus der Praxis der Gährungsindustrie. Beiträge zur Lebensgeschichte der Mikroorganismen. 3^{te} verm. u. neubearb. Aufl. mit 19 Abbildgn. Heft I, 92 Seiten. gr. 8^o. Mk. 3⁰⁰.

HALLIER, DR. ERNST. Die Pestkrankheiten (Infectionskrankheiten) der Kulturgewächse. Nach streng bakteriologischer Methode untersucht und in völliger Uebereinstimmung mit Robert Koch's Entdeckungen geschildert. Mit 7 Tafeln. 144 Seiten. Text. gr. 8^o. Mk. 8⁰⁰.

HITZIG, DR. ED. Ueber den Quärlulantenwahn-sinn, seine nosologische Stellung und seine forensische Bedeutung. Eine Abhandlung für Aerzte und Juristen. 146 Seiten. gr. 8^o. Mk. 5⁰⁰.

JAHN, HANS. Grundriss der Electrochemie. 311 Seiten. gr. 8^o. Mk. 8⁰⁰.

KROMPECHER, EDMUND. Die mehrfache indirekte Kerntheilung. Mit 9 lithogr. Tafeln. 275 Seiten. gr. 8^o. Mk. 4⁰⁰.

LEHMANN, DR. O. Electricität und Licht. Einführung in die messende Electricitätslehre und Photometrie. Mit 220 Holzstichen u. 2 Tafeln. 390 Seiten. gr. 8^o. Mk. 7⁰⁰.

NOLDE, BARON EDUARD. Reise nach Inneras-bien, Kurdistan und Armenien 1892. Mit dem Bild-niss des Reisenden und 1 Karte. 272 Seiten. 8^o. Mk. 4⁰⁰.

Pharmakologie und Toxikologie mit Beiträgen von vielen Ärzten redigirt von A. Brestaniski. 967 Seiten. gr. 8^o. Luabd. M. 25⁰⁰.

RICHTER, CARL. Die Galvanische Verzinkung des Eisens. Mit besonderer Berücksichtigung der neueren Methoden. Mit 18 Figuren im Text. 48 Seiten. 8^o. Mk. 1⁰⁰.

SCHMIDT, DR. CARL. Das Naturereigniss der Sintflut. Akademischer Vortrag. 63 Seiten. 8^o. Mk. 1²⁰.

WELTER, DR. ADOLF. Die Tiefen Temperaturen, ihre künstl. Erzeugung, ihre Einwirkung auf Tiere, Pflanzen, Microorganismen, etc., sowie ihre Anwendung in der Industrie. 84 Seiten. gr. 8^o. Mk. 2⁰⁰.

ZITTEL, KARL A. VON. Grundzüge der Paläontologie (Paläozoologie). Mit 2048 in den Text gedruckten Abbildungen. 971 Seiten. gr. 8^o. $\frac{1}{2}$ mor. Mk. 25⁰⁰.

ZWAARDEMAKER, DR. H. Die Physiologie des Geruchs. Mit 28 Figuren im Text. 324 Seiten. gr. 8^o. Mk. 9⁰⁰.

GUSTAV E. STECHERT,

810 Broadway, New York.

Macmillan & Co.'s Recent Publications.

Essays in Taxation.

By EDWIN R. A. SELIGMAN, Professor of Political Economy and Finance, Columbia College. 8vo, cloth, pp. x, 434. Price, \$3.00 *net*.

The Law of Civilization and Decay.

An Essay on History. By BROOKS ADAMS. 8vo, cloth, \$2.50.

The Beginning of the Middle Ages.

By the Late R. W. CHURCH, M. A., D. C. L., Sometime Dean of St. Paul's, Rector of Whatley, Fellow of Oriel College. 12mo, cloth (Eversley Series), \$1.50.

Acton.—A Lecture on the Study of History.

Delivered at Cambridge, June 11, 1895. By LORD ACTON, LL. D., D. C. L., Regius Professor of Modern History. 12mo, cloth, 75 cents.

Herodotus.—The Fourth, Fifth and Sixth Books.

With Introduction, Notes, Appendices, Indices. Maps by REGINALD WALTER MACAN, M. A., Fellow and Tutor of University College, Oxford, and University Reader in Ancient History. Vol. I., *Introduction, Text with Notes*. Vol. II., *Appendices, Indices and Notes*. 2 vols., 8vo, cloth, \$7.50 *net*.

Browning Studies.

Being Select Papers by Members of the Browning Society. Edited with an introduction by EDWARD BERDOE, M. R. C. S., author of "The Browning Cyclopaedia," etc. 8vo, cloth, \$2.25.

Century Science Series.

Edited by SIR HENRY E. ROSCOE, D. C. L., F. R. S.

NEW VOLUME.

Lyell.—Charles Lyell and Modern Geology. By PROF. T. G. BONNEY, D. Sc., LL. D., F. R. S., etc. With Portrait. 12mo, cloth, \$1.25.

Tait.—Dynamics.

By P. G. TAIT, M. A., Sec. R. S. E., Honorary Fellow of St. Peter's College, Cambridge, Professor of Natural Philosophy in the University of Edinburgh. 12mo, cloth, \$2.50 *net*.

Menschutkin.—Analytical Chemistry.

By N. MENSCHUTKIN, Professor in the University of St. Petersburg. Translated from the Third German Edition, under the supervision of the author, by James Locke. 8vo, cloth, \$4.00 *net*.

Meyrick.—A Handbook of British Lepidoptera.

By EDWARD MEYRICK, B. A., F. Z. S., F. E. S., Assistant Master of Marlborough College. With Illustrations. 12mo, cloth, \$3.75.

MACMILLAN & CO., 66 Fifth Avenue, New York.

SCIENCE

EDITORIAL COMMITTEE : S. NEWCOMB, Mathematics ; R. S. WOODWARD, Mechanics ; E. C. PICKERING, Astronomy ; T. C. MENDENHALL, Physics ; R. H. THURSTON, Engineering ; IRA REMSEN, Chemistry ; J. LE CONTE, Geology ; W. M. DAVIS, Physiography ; O. C. MARSH, Paleontology ; W. K. BROOKS, Invertebrate Zoology ; C. HART MEERRIAM, Vertebrate Zoology ; S. H. SCUDDER, Entomology ; N. L. BRITTON, Botany ; HENRY F. OSBORN, General Biology ; H. P. BOWDITCH, Physiology ; J. S. BILLINGS, Hygiene ; J. MCKEEN CATTELL, Psychology ; DANIEL G. BRINTON, J. W. POWELL, Anthropology.

FRIDAY, NOVEMBER 22, 1895.

Scientific Journals :—

The Journal of Geology.....707

New Books.....708

CONTENTS :

Glacial Phenomena between Lake Champlain, Lake George and Hudson River : G. F. WRIGHT.....673

Gill on the Early Segregation of Fresh-water Types.....678

Dry Dredging in the Mississippian Sea : CHARLES SCHUCHERT.....679

Antidromic Problems : G. MACLOSKEY.....681

Typhoid Fever Disseminated through the Milk Supply : H. L. RUSSELL.....682

Eleventh International Congress of Americanists : GEORGE BRUCE HALSTED.....683

Recent Investigations upon the Embryology and Pathology of the Teeth : H. F. O.....686

Current Notes on Physiography (XIX) :—

The Marginal Plain of China ; River Valleys of the Himalayas ; Origin of the Valley of the Rhone : W. M. DAVIS.....687

Scientific Notes and News.....689

University and Educational News.....691

Discussion and Correspondence :—

The Inverted Image on the Retina : CHARLES S. MINOT. *Shells as Implements* : O. T. MASON.

A Reply : FRANK C. BAKER. *Science and Cyclopedias* : LAWRENCE IRWELL.....692

Scientific Literature :—

Wilson's Atlas of the Fertilization and Karyokinesis of the Ovum : CHARLES S. MINOT. *Bedard's Monograph of the Order Oligochaeta* : W. MCM. WOODWORTH, FRANK SMITH. *Harris' Qualitative Chemical Analysis* : JAS. LEWIS HOWE. *Parinaud's La sensibilité de l'œil aux couleurs spectrales* : E. C. SANFORD. *Geology of the Green Mountains in Massachusetts* : J. F. KEMP. *Cross' Laccotite Mountain Groups of Colorado, Utah and Arizona* : J. B. WOODWORTH. *Kejcs' Bibliography of North American Paleontology* : GILBERT VAN INGEN.....695

Societies and Academies :—

Biological Society of Washington : F. A. LUCAS. *Entomological Society of Washington* : L. O. HOWARD. *New York Academy of Sciences* : J. F. KEMP. *The Geological Conference of Harvard University. The Academy of Science of St. Louis* : A. W. DOUGLAS.....702

MSS. intended for publication and books, etc., intended for review should be sent to the responsible editor, Prof. J. McKeen Cattell, Garrison on Hudson, N. Y.

Subscriptions and advertisements should be sent to SCIENCE, 41 N. Queen St., Lancaster, Pa., or 41 East 49th St., New York.

GLACIAL PHENOMENA BETWEEN LAKE CHAMPLAIN, LAKE GEORGE AND HUDSON RIVER.*

THE area between the south ends of Lakes Champlain and George and the Hudson River presents many very interesting glacial phenomena. The watershed between the basins of the St. Lawrence and the Hudson pursues a very remarkable course. Half-way Brook, a tributary to Wood Creek, which enters Lake Champlain at Whitehall, rises within the limits of the city of Glens Falls, upon the Hudson, and not more than a quarter of a mile from the Hudson. The brook occupies a broad, deserted river channel about one-half mile wide, leading through deep deposits of sand and gravel. The elevation of the gravel margins above the sea at Glens Falls is 343 feet; that of this deserted river channel is from fifty to seventy-five feet lower. A dam of twenty-five or thirty feet just above Glens Falls would turn the Hudson River through this old channel by way of Half-way Brook and make it a tributary to the St. Lawrence.

* A paper read before Section E, at the meeting of the A. A. A. S., at Springfield, Mass., August, 1895.

An extensive area northwest of Half-way Brook is occupied by sand plains and kames. For about a mile the sand plain bordering the channel presents a pretty sharp front towards the channel and slopes gradually away towards the mountains. On riding over this from north to south, while the slope is so gradual that one does not perceive it directly, it is made evident by the skyline which is formed by the tops of the mountains far to the south, giving one the sensation of being in a vast sandy plain surrounded by abutting mountains on all sides. I am indebted to Mrs. C. B. Hewitt for having my attention directed to this peculiar feature.

Nearer the head of Lake George and south of French Mountain the gravel deposits pass into those of a very broken character, with innumerable kames and kettle holes, one of the largest of which is occupied by Glen Lake, while an extensive series of eskers fill the depression west of French Mountain up to the head of Lake George.

Another remarkable channel extends from Fort Edward to Whitehall. This is followed by the Champlain Canal, whose summit level is 142 feet above tide. This valley is about a mile in width between Fort Edward and Fort Ann, a distance of about twelve miles, and is occupied most of the way by swamps. Between these places the canal occupies a dead level. On the west side, towards Sandy Hill and Glens Falls, this is bordered by a sharp margin of sand and gravel deposits at a level of about 300 feet. The eastern side of the Fort Edward-Fort Ann valley is bounded by low slate hills flanked up to about 200 feet above tide, or fifty feet above the valley, with deposits of Champlain clay. At Dunham's Basin, two miles above Fort Edward, however, the channel divides, one branch going east of a low slate hill and entering the Hudson a few miles below Fort Edward. The sand deposits west of the valley, to-

wards the angle of the river at Sandy Hill, are level-topped, extending about three-quarters of a mile east of the river, and occupying, at corresponding level, the inner angle inclosed by the river in the northeast corner of Saratoga county.

These sand and gravel deposits continue at an elevation of about 300 feet through Saratoga county along a belt following an irregular course west of the Hudson. The course pursued by the belt is through Moreau township, and the northwestern corner of Northumberland, thence diagonally through the center of Wilton to Saratoga Springs and Saratoga Lake. In Wilton township a line of eskers appears for several miles parallel with the Delaware and Hudson R. R. upon the northwest side. The elevation at Saratoga Springs is 322 feet. In the center of Wilton township it is slightly higher. Saratoga Lake is bordered upon the northwest side by two distinct terraces of sand and gravel of about fifty feet rise each. The lower terrace on the western side is, however, traversed north and south by two lines of swampy land and slack drainage. On the east of Saratoga Lake slate hills come down to the border.

Nearer the Hudson River, on the west side, through the towns of Northumberland, Saratoga and Stillwater, there is a continuous extension of Champlain clay, about 150 feet above the river.

Eight miles west of Glens Falls the Hudson follows a tortuous and narrow channel between the Luzerne Mountains and the Palmerstown range, which includes Mt. McGregor. There would seem to be no chance for a buried channel through this range, but the descent of the river from Palmer's Falls, just west of Luzerne Mountains, is upwards of 200 feet to Glens Falls, twelve miles distant, and from Glens Falls to Fort Edward, a further distance of about five miles, the fall is 150 feet more.

Upon examining the region south from Corinth, a remarkable passage is observed west of Mt. McGregor following in the main the upper portion of the valley of the Kayaderosseras River. For the first five miles this is occupied by numerous kames and kettle holes holding small bodies of water and very imperfectly drained to the

forms the watershed the small stream running into the Kayaderosseras meanders through a shallow, broad valley occupied by horizontally stratified sand and gravel. Without doubt this was temporarily the outlet of the Hudson River during the recession of the ice sheet. I did not have time to follow this valley down to see the

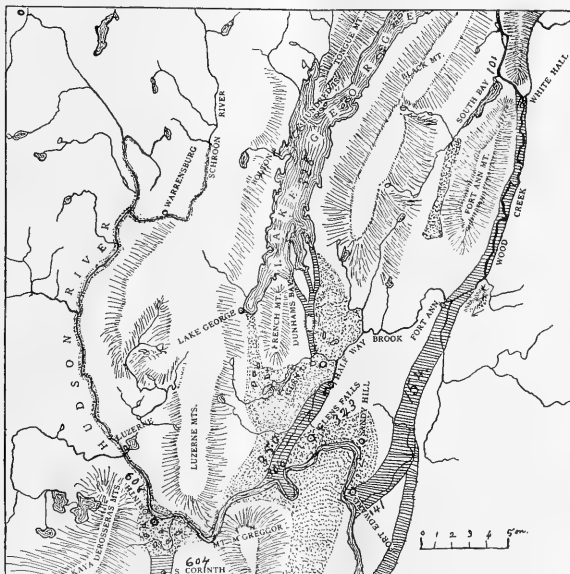

Fig. I. Dotted portion shows gravel deltas and kames. The cross ends abandoned channels. Figures, feet above tide.

northward. At South Corinth, at an elevation of 604 feet above tide, there is an extensive swamp about a mile wide, from which the water drains both ways. On the west of this swamp and stretching southward extensive deposits of gravel and sand, which may be a lateral moraine, flank the Kayaderosseras Mountains. This morainic belt is 300 or 400 feet above the valley. Immediately south of the swamp which

direction and limits of the gravel deposits derived from this source. So far as I could see, there was here ample space for a preglacial channel conducting the drainage in the upper Hudson along a more direct line than that which is now followed from Corinth to Glens Falls and Fort Edward and thence southward.

At Fort Ann the channel from Fort Edward to Whitehall is nearly crossed by

Archæan rocks which rise on either side to a height of two or three hundred feet. Evidently there is no space here for a preglacial channel of any size, though in building the lower lock upon the canal, which here descends about twenty feet, it is said that piles were driven to a depth of one hundred feet to secure foundations. Below these locks Half-way Brook joins Wood Creek and a broad, nearly level channel extends northward to Whitehall. It appears evident that the preglacial drainage went both ways from this Archæan ridge at Fort Ann.

But, while the present drainage runs east of Fort Ann Mountain to Whitehall, the main line of the depression occupied by Lake Champlain is to be traced west of this mountain through South Bay, at the head of which there is a pronounced terminal moraine extending across the depression, which is here about a mile in width, and filling it to a height of from two hundred to three hundred feet with glacial debris. The summit of this moraine is reached on the north side in a distance of about one-half mile, while southward a deposit of kames and of aprons of gravel descend gradually to Half-way Brook, in the vicinity of Fort Ann, a distance of about eight miles. How deeply buried this valley may be it is impossible to tell from surface indications; though on the north side it is clearly filled in the whole depth to the level of Lake Champlain. It is by no means impossible that by removing this glacial debris there may be discovered here a feasible route for a ship canal with water running directly from Lake Champlain to the Hudson.

Lake George presents interesting glacial problems throughout its entire length. Mr. Prentiss Baldwin, whose paper on 'The Pleistocene History of the Lake Champlain Valley' (*American Geologist*, Vol. XIII., March, 1794) sheds a flood of light upon

that region, left his notes upon Lake George unpublished. Failing to accompany me as he intended he gave me the benefit of his knowledge of the region, which had led him to surmise that the lake was held in place by morainic dams at each end, and that the preglacial drainage of the depression ran both ways, the divide being at the hundred islands between Tongue Mountain and Shelving Rock. Of this theory I was able to find abundant evidence.

The lake is 326 feet above tide and 225 above Lake Champlain, running for half its distance parallel with the Champlain and distant from it not more than four or five miles, there being between them a mountain range reaching at one point a summit of nearly 3,000 feet. The descent of the water at Ticonderoga is effected by two falls less than a mile apart; but, extending from the steamboat landing at Baldwin, there is ample space for a buried channel west of the falls; while just west of the upper fall a small stream exposes a section which shows compact glacial till filling the space down certainly to the level of the top of the lower fall. Northward from this point a well-defined depression about half a mile wide extends directly onward across Trout Brook, around Mount Hope, reaching Lake Champlain half-way between Ticonderoga and Crown Point. This depression is occupied by level-topped deposits of Champlain clay through which small streams have cut deep depressions without exposing rock. There can be little doubt that the former drainage of the north end of the Lake George depression extended by this route to Lake Champlain.

At the south end of Lake George the phenomena are equally or even still more interesting. The drainage of this part of the lake was not by Caldwell, but through Dunham's Bay to the east of French Mountain. For assistance in discovering the facts I am much indebted to Mr. Edward Eggleston,

whose residence is at the head of this bay. The three bays projecting southward from this part of the lake all end in swamps which unite together and extend a considerable distance south through a depression which is a mile or more in width, with French Mountain upon the west flanked all the way by a lateral moraine. The swamp is finally interrupted by a beautiful drum-

five or fifty feet above Lake George; while to the south gravel deposits fill the whole area to Half-way Brook, not more than a mile distant. There are some of the most enormous dry kettle holes in this area that I have ever seen. It would be a very easy matter to dig a canal which would turn the water of Lake George in this direction and deprive Ticonderoga of its water power.

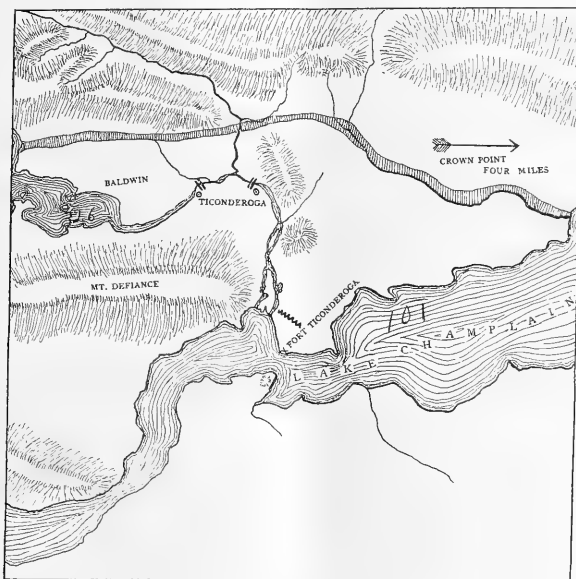

Fig. II. Preglacial channel between Lake George and Lake Champlain west of Ticonderoga.

lin about 250 feet high, one mile in length, and one-third of a mile in width. This is as typical in every respect of this class of hills as any which can be found in eastern Massachusetts, its longer axis being parallel with the valley; but it is not broad enough completely to fill the valley. On either side of it the watershed occurs in low-lying swamps not more than twenty-

The results of the investigations may be summarized in the following general statements:

1. The preglacial course of the Hudson was probably directly south from Corinth between Mt. McGregor and the Kaya-dorsseras range. This was filled up by glacial deposits at South Corinth to such a height that upon the retreat of the ice the

water was turned eastward through the narrow defiles across the Luzerne range to Glens Falls, where it found its present channel to the south.

2. The gravel deposits bordering the river east of the Luzerne range, and extending to Sandy Hill, are a true delta deposit of the Hudson when swollen by the torrents accompanying the melting of the ice over the Adirondack region during the last stages of the glacial period. The limitation of the amount of debris and the brevity of the period appear in the fact that the channel between Fort Ann and Fort Edward was not filled by gravel.

3. The gravel deposits extending through Saratoga county were made at an earlier stage of the recession, when ice occupied not only the region to the north, but the eastern part of the Hudson Valley to a considerable distance farther south. This view is supported not only by the line of eskers referred to, but by the fact that throughout this region the glacial striae are from northeast to southwest. These are very pronounced in the vicinity of Saratoga Springs and at Fort Ann. It would seem that the retreat of the ice was from the southwest, and that the area about the mouth of the Mohawk was earlier free from ice than were the flanks of the Green Mountains north of Troy; so that during the closing stages the line of resistance for the movement of ice was diagonally across the Hudson toward the area just south of the Kayadarosseras Mountains.

4. The main line of the Champlain Valley extends southward through South Bay, while the main line of the Lake George Valley extends southward through Dunham Bay to the Hudson.

5. The subsidence of the Champlain epoch, which amounted to about 300 feet in the vicinity of Ticonderoga, was probably not much less in the vicinity of Fort Edward; for it seems evident that the delta of

the Hudson River, which came down at Sandy Hill to the border of the Fort Edward-Fort Ann channel, must there have met still water nearly up to its level of 300 feet. The deposits of sand were sharply limited by deep water, while the clay had ample opportunity to settle over all the areas along the Hudson up to a height of from 200 to 250 feet above tide.

6. There is nothing in this region which indicates a post-glacial depression of more than 300 feet, but everything to indicate the opposite. All the gravel deposits above that level are of the nature of eskers and kames.

7. The preglacial watershed between the St. Lawrence and the Hudson was probably near the middle of Lake George and at Fort Ann.

G. F. WRIGHT.

OBERLIN, O.

THE EARLY SEGREGATION OF FRESH-WATER TYPES.*

DR. GILL prefaced his communication with the statement that it was a familiar fact that some of the most primitive types of animals were represented in the fresh-waters and in them only; this is especially the case with true fishes. It is also well known that fresh-water animals show all degrees of relationship to salt-water forms, ranging from species that are anadromous or catadromous to those that are representatives of families or groups of families confined to the fresh water. But it has not been appreciated how radically a large proportion of the fresh-water fauna has been differentiated from the marine. The perception of the extent of this differentiation has been delayed by the false taxonomic principles that have long prevailed. A typical instance of the truth of this proposition is furnished by the Ostariophysal

*Abstract of a paper presented by Dr. Theo. Gill before the meeting of The National Academy of Sciences, Philadelphia, October 30th.

fishes. This great group includes nearly two-thirds of all fresh-water fishes and comprises the Characinids of America and Africa, the Gymnotids of America, the Cyprinids of the northern hemisphere and the various families of Nematognaths. These groups, in most systematic works, have been widely separated and severally associated with forms with which they have no intimate relationships. As long as such views prevailed, the appreciation of the great importance of the geographical distribution of the groups was concealed from view. But with the recognition of the unity of organization, and, consequently, unity of origin of the whole, a fresh conception of the relations of that whole to the faunas of the present and past breaks in upon us. We are now justified, from the morphological data at hand, in claiming that all the groups enumerated as OSTARIOPHYSI and belonging to the orders PLECTOSPONDYLI and NEMATOGNATHI are naturally segregated and not closely related to any existing aboriginal marine types. The marine forms of the family *Plotosidae* and the siluroid sub-family *Tachisurinae* must be regarded as divergents from fresh-water forms. With this assumption it becomes necessary to postulate that all the numerous families of the Plectospondylous and Nematognathous orders are derivatives from primitive fresh-water types. The extent of this divergence may be inferred from the numerous morphological modifications. The antiquity of the origin of the super-order must be commensurate with the extent of divergence. Far from originating in the advanced tertiary, it is not unreasonable to infer that the parent stock had become acclimatized in the fresh water as far back as the early mesozoic; instead of the parent land being the Himalaya region or highlands of Asia, as claimed by Dr. Günther, it is much more likely to have been in the southern hemisphere—possibly

an antarctic continent. At any rate, the present geographical distribution of the representatives of the respective orders seems to render such an origin most probable. The reasons were given in detail.

The distribution of the group thus outlined is to some extent collateral with that of certain mollusks and crustaceans, and the facts respecting the range of the unionaceous bivalves and the ostracod crustaceans were especially discussed.

It is quite true that there is no paleontological evidence for the inferences and assumptions thus made, but this is simply because the geological record is woefully imperfect and many of the changes took place in continental areas now submerged or little explored. No remains of Ceratodontids, which must of course have lived to continue the line from the Jurassic species to the present, have been found. The same conditions that have affected the one must have prevailed for the others.

DRY DREDGING IN THE MISSISSIPPIAN SEA.

THE U. S. National Museum has recently secured large collections of Devonian fossils, chiefly corals, from New York, Ontario and Michigan. The first casts were made in the Corniferous limestone in the vicinity of LeRoy, New York, where the cherty limestone underlying the quarry layers is charged with an abundance of corals, the net sometimes having masses of *Diphyphyllum* of more than a hundred pounds weight. At Williamsville, near Buffalo, corals are also plentiful, but here the fauna is smaller and the species are not so common as at LeRoy. However, a short distance west of Buffalo, to the north and west of Port Colborne, in Ontario, well-preserved Corniferous corals are present in great variety and abundance. Also at Hagersville, large masses of various compound species are numerous, many hundred tons of which, two years ago, were broken up

and used for road making. At all the localities mentioned, except Williamsville, the corals are in a siliceous pseudomorphous condition; *i. e.*, the original carbonate of lime has been replaced by amorphous silica. The surrounding limestone being so much softer, on weathering it decomposes far more rapidly than the included chert bands and corals, and leaves them lying loose in the soil or among the flakes of chert thrown up by the farmer's plow. Collecting places are usually easily discovered, since outcrops of the Corniferous limestone are generally indicated by stone walls surrounding the farms or by stone piles scattered over them. Four miles west of Port Colborne, at one of Prof. Nicholson's localities, there is a rock pile more than fifteen feet high, every piece of which contains corals or mollusca. At such places, one is interested often for days in turning over the rocks and selecting the better specimens, all of which can, if necessary, be further developed with dilute hydrochloric acid.

Towards the western portion of Ontario, at Thedford, the next younger, or Hamilton, formation is well exposed, and here again corals are very abundant. This locality is probably the most famous for Middle Devonian fossils in North America, and visiting collectors will find themselves pleasantly surrounded with people who understand that a collector of fossils is neither a curio collector nor insane. It is painful to have the same question asked many times each day: "Mister, what are you looking for?" and after one has explained, to observe in the listener no comprehension of the first principles of geology, or, worse, to be told: "I suppose you take them home and gild them." But at Thedford one is either left alone or assisted to find localities, or, better still, allowed to collect in the cabinets of the minister, teacher, store-keeper, tailor, or section boss. What a splendid place Thedford is to the collector

of fossils can be surmised on stating that from one to five thousand specimens of the brachiopod *Spirifer mucronatus* can be picked up in a day. Thedford, formerly known as Widder, is made famous by the writings of Billings, Hall and Whiteaves, and is visited annually by collectors. Sometimes a college professor turns up with a car load of students, including ladies. The local enthusiasm, however, has been developed by the intelligent efforts of Rev. Hector Currie, who, in a village of less than one thousand inhabitants, is surrounded by four enthusiastic collectors.

The Hamilton formation is again observed on both sides of the southern peninsula of Michigan, near its northern extremity. Thunder Bay Island, situated twelve miles east of Alpena, is almost one mass of the coral-like *Stromatopora*, growing in thin concentric layers one upon another, until single colonies assume a diameter of from a few feet to the great width of three yards. Upon these the sea of Lake Huron has been pounding for ages, weathering away the top of each wavy dome and separating the colony into innumerable, concentric, fractured layers. In a general way, each mass resembles a transverse segment of a huge tree trunk, and is often taken for such by the local life-saving crew. In the quarries north of Alpena, layers of limestone nearly barren of fossils and less than ten feet thick are seen to increase rapidly to a thickness of nearly twenty feet toward the coral reef, which is built up by *Stromatopora*, large *Aerovularia*, numerous compound branching corals, and here and there a shell or the beautiful calyx of a crinoid. Petoskey, on Lake Michigan, is another well-known Devonian locality, and is famous not only as a summer resort for hay-fever sufferers, but for the 'Petoskey stone' as well. This stone is usually a polished fragment of the coral *Aerovularia davidsoni* or of *Favosites alpenensis*, and local

curio dealers search for them in a novel manner. This is done by sprinkling with water the pebbles on the beach of Little Traverse Bay. By the temporary polish thus produced, the dealers are enabled to gather the Petoskey stone in a nearly marketable condition for tourists.

CHARLES SCHUCHERT.

U. S. NATIONAL MUSEUM.

ANTIDROMIC PROBLEMS.

In my paper on Antidromy* I have tried to show: (1) that there is a diversity among the individuals of every species of flowering plants, some with a tendency to dextrorse, others to sinistrorse twisting; (2) that this can be traced more or less through the different orders of plants, in the seeds, stem, phyllotaxy, anthotaxy and seed vessels; (3) that it is apparently caused in most cases by the place of origin of the anules on the right or left margin of a carpellary leaf.

The general evidence for this view is to be found at large; and without going into details, I may say that further observations confirm the conclusions first reached. The article by Professor Beal in the *American Naturalist*, 1873, with interesting notes on two kinds of spirality in the cones of the same trees of the Coniferae, presented a difficulty when first called to my notice; but I find that the young cones are homodromic with each other and with the leaf-spirals of the Coniferous trees, whilst the older cones undergo a change by displacement of the scales, resulting in a false antidromy in the same tree. On growing maize-plants from grains taken from one column of an ear, the forthcoming plants are of different kinds. (This is to correct the statement in my former paper.)

I have not yet been able to extend the law into the higher cryptogams; though some things in ferns make me hopeful of succeeding with them, as also some of the

illustrations in Schimper's *Vegetable Paleontology* and in other books. A few illustrations in the books are, I think, erroneous; thus Engler and Prantl give *Helicteres* (Sterculiaceae) and with carpels *antidromic on the same plant*. I think this will be found erroneous, as I know the same work is wrong in the figure of *Erodium*, whose fruit-beaks are all and in all plants dextrorsely twisted (that is in the direction of the thread of a screw); as are those in *Pelargonium*. The carpels of these do not appear to be antidromic (though the leaves are so) as between different plants; and in *Impatiens*, of the same order, both carpels and leaves are antidromic. Sachs' *Botany* gives a figure with a wrong spiral for the elaters of *Equisetum* (and I confess my own sin here); they run dextrorsely in all the plants.

The spirals of the oogonium of *Chara* are always sinistrally twisted, given wrong in Dodel-port's diagram. The peristome of *Barbula* and other mosses, if twisted, is usually dextrorse, and the seta in opposite directions (didromic) in its upper and lower parts. I think the inner peristome of *Buxbaumia* is sinistrorse. The anchoring cable of *Vallisneria* is didromic, twisted dextrorsely above and sinistrorsely below, so as to bring the two ends nearer together by a central turning. The same is true of the awns of *Stipa*, *Danthonia*, and many other grasses; the base being a dextrally twined ribbon and the tip a sinistrorse seta; when it is wet the basal ribbon unwinds so as to screw the seta into the earth as into the wool of sheep or the clothing and skin of men, as Captain Cook's seamen discovered in the last century in northeastern Australia. These are cases not of true Antidromy, but of Didromy, a double twist in the same organ.

As mentioned in my former paper, *Richardia*, *Iris* and *Juncus* appear to produce antidromic plants not merely by seeds, but by

* *Torrey Bulletin*, September, 1895.

division of the rootstalk. A still more difficult case is the Bilsted (*Liquidambar styraciflua*). This tree can change its phyllotaxy with its branching; it may divide at the ground, sending up two stems, both of the same or of antidromic phyllotaxy; each stem may produce branches of both kinds, and the branches may bear secondary branches of their own or different spirality. Within any one branch, the phyllotaxy is definite, at $\frac{2}{3}$ divergence; one way or the other, for the bud scales of the annual innovations, as well as for all the leaves; and the order does not change within a branch, but between a branch and its sub-branches the order may or may not change. On the upper surface of the horizontal branches are the cork ridges which curve (irregularly) to right or left in harmony with the phyllotaxy of that branch.

The only explanation that occurs to me as possible is that Bilsted may have a latent tendency to produce both orders of phyllotaxy, that some slight inequality of nutriment may determine which shall start first, and that whichever gets the start is able to retain the preponderance for the particular branch, and the same influence is felt by the cortical growth. But the severe strictures of Sachs (*History of Botany*) on the old literature of phyllotaxy is a wholesome caution not to be speculating beyond the evidence; his criticism, however, is directed against theories invented by mathematicians, and not against those that would arise from a consideration of the plant's ontogeny.

G. MACLOSIE.

PRINCETON COLLEGE, October 25, 1895.

TYPHOID FEVER DISSEMINATED THROUGH THE MILK SUPPLY.

THE relation of milk to the spread of infectious diseases has been most strikingly shown in an epidemic of typhoid fever that occurred at Stamford, Conn., during this year, the official report of which has been

recently issued by Prof. H. E. Smith. The evidence gathered shows beyond all question that the disease was propagated by means of the milk supply, so that the epidemic possesses unusual interest for students in bacteriology and hygiene.

The epidemic broke out in April, and within six weeks 386 cases were reported in a town of about 16,000 inhabitants. Of this number, 65 cases or 16.8% were five years old or under, while over one-third of the total number were under ten years of age.

The mortality statistics of the State of Connecticut for the last 15 years show that less than 10% of the total number of deaths from typhoid have been under 10 years of age. In view of this, the large number of cases in early childhood has a peculiar significance in explaining the origin of the epidemic, as the infection of the milk supply would be more apt to manifest itself in infants than in adults. As soon as the milk supply was suspected, its sale was prohibited, and in fifteen days (about the usual period of incubation of this disease) after this prohibition went into effect the number of new cases dropped from an average of over ten a day to less than two. It was further shown that out of the total number of 386 cases, 352 or 91.2% lived in families that were supplied with milk from the same dealer. In 14 other cases milk from this same dealer was consumed by parties at a café and bakery. In 8 of the remaining cases milk was supplied the parties by the producer from whom the milk peddler obtained his supply. This makes a total of 97.1% of all cases that received the milk, either directly from the producer or indirectly through the milk dealer who peddled the milk. As the milkman in question only supplied about 9% of the total amount used in the town, the number of cases that developed on his route is of especial interest.

The evidence of a contaminated milk supply was overwhelming, but how to account

for the infection of the milk was not so easy. The milk might have become infected in the hands of either the dealer or the producer. Inasmuch as a few cases of the epidemic developed that were not supplied with milk from the dealer, but were supplied by other parties that had been using some of the milk cans in common with him, the presumption was strongly in favor of the view that the infection occurred while the milk was in the hands of the dealer. It seems that the dealer was in the habit of washing out his cans himself, and, while he obtained most of his supply from the producer in question, at times he secured an extra supply from other parties. No particular attention was paid to the cans that were used, so that they were often mixed up and returned to different parties after they had been cleaned by the dealer.

No case of typhoid had occurred at the house of either the dealer or the producer, so that direct infection of the milk did not seem probable. An examination of the water supply was then made. At both places shallow wells were found, that of the milk dealer's being only thirteen feet deep with nearly twelve feet of water in it. The well was surrounded on several sides by privies, an extremely foul one being within twenty-five feet of the well. It was the habit of the dealer to first rinse out the milk cans with water from this well, then they were thoroughly cleansed with hot water and soda, and finally rinsed in cold water again that was taken from this well.

Both the bacteriological and chemical examination of water from the two wells was made.

Neither of the wells were good and that of the milk dealer was grossly contaminated, having nearly 70,000 germs per cubic centimeter.

Typhoid bacteria were not discovered, but this is not surprising. It is possible that the privy near the well may have been

used by some unknown person, as it was close to and easily accessible from a railroad. There is no positive evidence, however, that the water was contaminated except in the history of the epidemic. The evidence, however, is so strong that there can be no valid objection to the conclusion that milk was infected by washing the cans with contaminated water.

H. L. RUSSELL.

MADISON, WIS.

ELEVENTH INTERNATIONAL CONGRESS OF AMERICANISTS.

ON the fourteenth of October, in the beautiful Salón de Actos de la Escuela Preparatoria in the City of Mexico, was inaugurated a scientific meeting, not only memorable for our great sister Republic, but in many respects unique and *sui generis*.

Though to the official proceedings in Spanish reference must be made for an authoritative account of the mature work submitted to this august assemblage, yet the readers of SCIENCE may not be uninterested in a few words about the external and social aspects of the Congress.

The preliminary session on October 14th was remarkably well attended and was stamped by an air of elegance, distinction, prestige, which is by no means noticeable at our own science meetings.

The Cabinet Ministers of Mexico, the Ministers of the Great Powers of Europe and America, the Governors of the Mexican States, mingled with the men of science, made an array which we could not duplicate outside of Washington. The roll of the delegates was called, and each one presented his credentials, which were then scrutinized.

In accordance with Mexican social etiquette, the President of the Republic, Porfirio Diaz, was debarred from being present because of the recent death of his father-in-law, Romero Rubio.

The Congress, to express its respectful regrets in this matter to President Diaz, appointed a special commission of four, el Excelentísimo Sr. D. Justo Zaragoza, a delegate from Spain, Dr. George Bruce Halsted, a delegate from the United States, and two delegates from Mexico.

This commission visited the President in the National Palace, and to its brief address, prepared and delivered by the chairman, an appreciative answer was returned, and both were read in the next general session of the Congress. This session began at 4 o'clock on October 15th, in the same hall, once the chapel of the oldest university on this continent, San Ildefonso, now modestly called Escuela Preparatoria, though the people cling to the old name.

Sr. Julio Zárate read the minutes of the preceding meeting, and then the general secretary, Sr. Trinidad Sánchez Santos, read an account of the work of organization, which began last April.

At 21 of the 23 meetings of 'la junta organizadora' Sr. Lic. Joaquin Baranda, Secretary of Justice and Public Instruction, presided.

This may give some hint of how much the Congress owes to this truly enlightened man, founder also of the Anthropological Museum, which for its age is unsurpassed. The junta sent special invitations to eminent scientists.

From special gifts and offerings of men of science the junta made a highly valuable collection, particularly important for the study of the pre-Columbian period in America.

With the object of itself making a worthy contribution, the junta had translated twenty-seven of a precious collection of songs of the aborigines found in a MS. of the Biblioteca Nacional. Arrangements were made for an excursion of the delegates to visit the ruins of Teotihuacan and Mitla, those worthy monuments of antiquity.

Following this reading, the President of the Congress, Joaquin Baranda, occupied 'la tribuna.' He praised the Congress at Stockholm for determining, in accordance with true scientific method, to meet in Mexico and study at first hand, objectively, the monuments of American antiquity. He enumerated with erudition the archaeological treasures of Mexico, from the northern frontier to Yucatan, and especially those in and immediately about the beautiful capital. He referred to the Calendar Stone, reflection of the astronomical acquirements of the Aztecs and the celebrated Cross of Palenque, mysterious sculpture of the Mayas, a seeming prophecy of Christianity, though long before Christ.

He spoke of the codices, maps, records of tribute to the antique monarchs, now being studied with more enthusiasm than ever before. He spoke of Humboldt, from the peak of Chimborazo enveloping America in that profound regard which made him her scientific discoverer. He finished by welcoming the delegates in the name of the people and the National Government, which rejoices to aid whatever signifies progress.

Sr. Lic. Ignacio Mariscal, secretario de relaciones exteriores, in the name of the President of the Republic, then declared the Congress open.

That evening at 8 o'clock a banquet was given by the City Council to the Americanists in the Municipal Palace. There were 200 guests, and the newspapers stated the cost of the banquet at six thousand dollars.

The whole floor from the very entrance was carpeted and heavily strewn with natural cut flowers, on which the guests trod. The records of this City Council date back to 1524, the first minutes being signed by Hernan Cortes, the 'conquistador.' Electricity, gas and wax made a blended light in the beautiful dining hall. The floral decorations were, of course, superb.

The first after-dinner speech was by Sr.

Sebastian Camacho, Mayor of the city, an elaborate eulogy of science and welcome to the Americanists in the name of the city.

The President of the Congress responded.

Alfredo Chavero, author of that rare tome, 'Mexico a traves de los Siglos,' followed with a toast to the three historians of Mexico—Fernando Romirez, Manuel Orozco y Berra and Joaquin Garcia Icazbalceta.

Dr. Edward Seler, of the University of Berlin, the greatest of all Americanists, spoke in Spanish, maintaining that the civilization of the ancient nations of Mexico was wholly indigenous. When this charming and absolutely unaffected scientist hesitated for a Spanish word, and nervously moved about the seven wine glasses in front of him, his wife, sitting opposite, the only woman at the banquet, herself a brilliant Americanist, suffered feminine tortures for her husband, all unnecessarily, for his speech was the greatest success of the evening, and applauded to the echo.

Dr. Antonio Peñafiel, the most respected of Mexican archaeologists, spoke of the earlier historians, Clavigero, Cavo, Veytia and others.

The academician of Spain, Justo Zaragoza spoke of how peace and prosperity under President Diaz had prospered research into Mexico's remote past.

Just after the formal adjournment, Governor Próspero Cahuantzi, a gigantic pure Indian, gave in the Aztec language a speech seemingly eloquent, to which Dr. Seler gave intense attention and in part understood.

At ten next morning, October 16th, the Congress visited the wonderfully rich National Museum. Besides a new catalogue of the Department of Archaeology, five other new catalogues had been prepared for the visit of the Congress and were presented to all wearing the badge of 'Americanistas.' Num. 1, Catálogo de la Coleccion de Mami-

feros del Museo Nacional, segunda edicion; Num. 2. Coleccion de Aves; Num. 3. de Reptiles, were by Alfonso L. Herrera, to whom a prize was lately awarded by our Smithsonian Institution.

The highly creditable Num. 4. Catálogo de la Coleccion de Antropologia del Museo Nacional, 164 pages, with tables, was by Alfonso L. Herrera and Ricardo E. Cicero. The 'Guia para visitar los salones de Historia de México del Museo Nacional' was by Jesus Galindo.

The display lent by the State of Vera Cruz, and the recently discovered colored pictorial ancient manuscripts attracted great attention.

One of these, in depicting the deliberate shooting with arrows of captives bound to a ladder, smacked strongly of the stories of our own 'Indios bravos.'

The rampant cannibalism of the interesting aborigines also came out strongly.

At 4.10 in the University the session was opened by a reading of the minutes, and then the 'Chicomostoc Memoirs,' by L. Amador, of Zacatecas, were read by Roman S. de Lascrain. A paper on the conditions of commerce, money and exchange between the towns of antique Mexico, by J. W. Bastow, was read by J. Breaux.

A discussion about Toltec and Aztec idioms was started between Dr. Seler and Sr. Leopoldo Batres, conservator of public monuments, in which discussion of course Sr. Batres had no chance.

At ten o'clock the next morning, October 17th, the Americanists visited the 'Escuela de Bellas Artes,' whose genial director, besides his Spanish, is fluent in English and German. Each member of the Congress was presented with a specially prepared treatise on Mexican Art, of the very highest interest and value.

At four o'clock the regular sessions were continued.

At eight o'clock on the morning of Oc-

tober 18th an excursion to Popotla was made by wagons, starting from 'la Plaza de la Constitución,' opposite the 'Portal de Mercaderes.'

This was chiefly a visit 'al árbol de la Noche Triste,' the famous tree against which Cortes rested and wept on the night of his terrible defeat. The tree, unfortunately, seems dying, but its tremendous trunk, a wooden tower, may still be a landmark for centuries.

The tree of Montezuma, at the back of Chapultepec, is still flourishing, one the grandest and most impressive of living things on this earth.

At ten o'clock a visit was made to 'la Escuela Nacional de Ingenieros,' where is perhaps the greatest collection of large meteorites in the world.

At four o'clock again in session in the Escuela Preparatoria.

But already we have followed long enough to give an insight into the life of this most enjoyable Congress, and while the fortunate Americanistas go south by rail to Oaxaca, thence to ride to Mitla, digging in the prehistoric past, we face again the unsoftened raw newness of our own United States.

GEORGE BRUCE HALSTED.

AUSTIN, TEXAS.

RECENT INVESTIGATIONS UPON THE EMBRYOLOGY AND PATHOLOGY OF TEETH.

The embryonic development of the teeth is now a subject of most active investigation, and we are constantly receiving new communications from Leche, in Stockholm; Kükenthal, in Jena, and Röse, in Freiburg. The most striking discovery is that of the existence throughout the mammalia of remnants of two series of teeth, preceding the milk and permanent series. The teeth represented in these two series are entirely vestigial; both precede the embryonic development of the milk teeth, and are indicated merely by indentations of the

dental fold. So far as known, these germs never develop enamel, but they constitute the most positive evidence of the derivation of the mammalia from reptilian or amphibian ancestors with a multiple dental succession. These 'prelacteal' teeth, as they are called, were first observed by Leche, in 1892, in certain Insectivora, but they have subsequently been found among the Marsupialia and in the seals. Röse has now found unmistakable vestiges of these teeth in the human jaw. Man, therefore, in common with many other mammals has four sets of teeth, instead of two as formerly supposed.

Röse's investigations upon the teeth of Amphibia Reptilia and fishes demonstrate conclusively the truth of Hertwig's theory that teeth are modified scales which have passed into the mouth cavity. He finds that the rudiments of the first series of teeth in each of these types develop exactly after the manner of the placoid dermal scale. The second series of teeth develop after an intermediate type, and it is only the third series of teeth which develop from the typical dental fold lying suspended within the mesoblast, or lower tissue of that layer. Dr. Röse, with Prof. Kükenthal, of Jena, has been the most active supporter of the theory of the origin of complex tooth crowns by concrescence of primitively separate cusps, and this 'concrecence theory' has spread very rapidly in Germany as an explanation of the mode of origin of the elaborate tooth forms. There are very slight grounds of evidence for it among the mammalia; in fishes, however, it has long appeared probable that the well-known type of shark tooth (*Lamna*), consisting of three cusps united at the base, so abundantly found in the phosphate beds of South Carolina, represents a concrescence. Röse has now made a very careful study of the tooth development of *Chlamydoselachus anguineus*, Garman, and finds conclusive evidence that the com-

pound crowns of this type are formed by the concrecence of three separate denticles.

Dr. Carl Röse has also completed a most valuable investigation upon the causes of the decay of teeth. (*‘Ueber die Zahnverderbniss in den Volksschulen.’*) With the aid of two colleagues, in the schools of Freiburg and the Black Forest he has examined 7,364 children and 179,087 teeth. Special objects of the investigation were the relations of dental caries to the geology of the country, and the presence of a greater or less amount of lime salts in the water, and, secondly, the influences of the consumption of different kinds of farinaceous food. In general the use of water or food poor in lime salts affects the development of the teeth very unfavorably; and the use, especially, of fine milled white bread is very prejudicial to sound teeth, whereas the use of the common black bread keeps the teeth clean and the gums in a healthy condition. As regards stratigraphy the investigation shows that as we pass from granitic to overlying calcareous formations there is a steady decrease in the number of unsound teeth—falling from 35.3 to 16.1%. These figures are taken without regard to the character of the bread and other food consumed by the children and show exclusively the influence of water. The conclusion is that the worst teeth of the calcareous districts are always better than the very best teeth found within the non-calcareous districts, the degeneration of the teeth being indicated by a yellowish white and bluish gray color.

In the matter of food, meat is a great luxury among the peasant children, enjoyed, if at all, only upon Sundays, and can be left entirely out of account. Dr. Röse finds that the consumption of the German ‘Kuchen’ (made of white flour with milk, butter or oil and more or less sugar, raisins, etc.) is very prejudicial to the teeth; and, in fact, the very worst teeth are regularly

found within those districts where these cakes are habitually consumed. The conclusion as to food is that the very best form of foods, so far as teeth are concerned, is the black bread with its coarse, thick crust. The investigation extends to the relation between the general condition of the mouth and gums and epidemics of diseases such as diphtheria, which principally affect children, and Dr. Röse maintains that there is a direct relation between the unhealthy condition of the teeth and gums and a predisposition to epidemic diseases. He believes that in times of epidemics these disease germs are found in the mouths of nearly all children and that a healthy condition of the mouth resists the infectious power of the germ. As regards sex, there is very little difference between the boys and girls in the matter of decay. It is an interesting point that the development of the teeth is very much more rapid in girls than in boys, so that in children of the same age a much larger proportion of milk teeth are found among boys than among girls.

The article closes with a strong appeal for the education of children in the schools in the proper care and protection of the teeth, and the author recommends not only the careful instruction of children in this respect, but also the award of prizes.

H. F. O.

CURRENT NOTES ON PHYSIOGRAPHY.

THE MARGINAL PLAIN OF CHINA.

SKERTCHLY AND KINGSMILL describe ‘the loess and other superficial deposits of Shantung, North China’ (*Quart. Journ. Geol. Soc., London*, li, 1895, 238–253), recognizing the alluvial delta plains of the great rivers, a plain of marine sands, and a somewhat denuded lowland of loess. The delta of the Yangtse is estimated to increase by two square miles a year. The sandy marine plain is broadly developed over a bay-like area up the Yellow River,

back of its delta. The surface of the loess is diversified by valleys of denudation. This peculiar formation is explained as consisting neither of glacial flour nor æolian deposits; it is 'plainly stratified,' certainly of aqueous and probably of marine origin; but in the discussion following the reading of the essay the latter conclusion was disputed by several geologists present at the meeting. The outer margin of the loess lowland is an old, rounded sea cliff, with headlands and bays, overlooking the uniform level of the delta; but details of this interesting geographical feature are unfortunately not given.

RIVER VALLEYS OF THE HIMALAYAS.

THE occurrence of the chief water parting back of the highest range of the Himalayas has called forth various explanations, to which R. D. Oldham, Superintendent, Geological Survey of India, adds another (Jl. Manchester Geogr. Soc., ix, 1894, 112-125). He suggests that the south-flowing rivers have extended their headwaters backward through the main range, by reason of their great slope in comparison with the rivers that flow northwards from the mountains to the elevated table-lands of Thibet. The contrasted river slopes on the two sides of the present main divide are illustrated by a well drawn section. The author points out that the divides thus shifted away from the axis of the range always provide low passes through the mountains, because the former high slopes of the axial divide have been obliterated. [Heim describes terrace-like remnants of the upper parts of beheaded valleys in cases of this kind in the Alps, overlooking the deepened valley of the beheading stream; but no mention of these details is made by Oldham.] The larger rivers are thought to be antecedent to the out ranges of the Himalayas, across which they have cut profound gorges; but it is suggested that the heavy alluvial de-

posits in the inner valleys were formed while the uplift of the outer range decreased the grade and the activity of the rivers.

ORIGIN OF THE VALLEY OF THE RHONE.

THE geological changes which have preceded and led up to the existing structure of the valley of the Rhone are traced by Depéret, of Lyons (Aperçu sur la structure générale et l'histoire de la formation de la vallée du Rhône, Ann. de Géogr., Paris, iv., 1895, 432-452, two maps). The theme is an interesting one, and its treatment appears to be thoroughly competent in a geological sense; but although published in the most scientific of French geographical journals under the heading of *Géographie régionale*, the essay appears to us to lack the essential quality of geographical matter, inasmuch as the sequence of geological changes in the order of time, and not the development of existing superficial forms, constitutes its chief object. Anything that will throw light on existing forms contributes to their recognition and may be properly included under physiographical geography. No collateral study gives more assistance of this kind than geology, from which a knowledge of the structure of a land mass and of the processes at work upon it are derived; but structure and process must be studied strictly in relation to the forms sculptured by their interaction, if the study is to have a geographical flavor; and not simply in relation to their order of occurrence, for then the flavor is wholly geological. The first step in the study of form as dependent on structure and process is a thorough knowledge of local geology; this being already acquired and presented for the valley of the Rhone in the above-named essay, we hope that the learned author will now take the next step and describe the regional geography of the valley.

W. M. DAVIS.

HARVARD UNIVERSITY.

SCIENTIFIC NOTES AND NEWS.

THE State Board to select a new magazine rifle for the National Guard of the State of New York organized at Albany, Tuesday, November 12th, Col. A. D. Shaw, of Watertown, in the chair. The other members are Professor R. H. Thurston, of Ithaca, and Mr. E. W. Bliss, of Brooklyn. Mr. H. E. Abell, of Brooklyn, was made secretary to the board. After consultation with Governor Morton and the Adjutant General's office, it was determined to notify inventors that they would be allowed until December 15th to present arms for examination and test at the office of Adjutant General of the State. Only American inventions can be accepted for examination. All tests are to be made at the State Camp at Peekskill. The purchase of 15,000 guns is authorized at a price not to exceed, for guns and accessories, \$20 each. Aside from the construction and action of the lock and repeating mechanism and the behavior of the gun in action, it is expected that the question of varying the calibre from that of the U. S. Army, and that of interchangeability in other respects with the army gun, will be carefully studied.

A BILL has been introduced into the Congress of Mexico empowering Marshal Saville, the agent of the American Museum of Natural History, in New York, to make archaeological excavations in Mexico. The bill provides that half of the objects secured shall be the property of the museum, and is said to have the approval of President Diaz.

PROF. FREDERICK STARR, of the University of Chicago, will go in December to Guadalajara, Mex., to study a submerged city in Lake Chapala, and the mountain dwarfs inhabiting the mountains near by. His intention is to try to determine whether these people are racially small or have become so by disease.

A PETITION praying the Royal College of Physicians, of London, to admit women to examinations and diplomas was the subject of an interesting debate before the *Comitia* on October 24th. The petition was rejected by fifty-nine votes to fifty. Eighteen years ago the same question was debated in the College, and the admission of women was rejected by sixty-eight votes to sixteen.

M. PERROTIN described before the Paris Academy of Sciences, on October 28th, the new observatory on the summit of Mounier, in the Maritime Alps. The observatory was planned by M. Bischoffsheim as an annex to the Nice observatory and is at an altitude of 2,741 m. In addition to a stone house for the astronomer and his assistant, there is a revolving dome, 8 m. in diameter, in which is mounted a 38 cm. equatorial telescope. A meteorological station has been organized in conjunction with the observatory. The observatory is connected by telephone with the village of Beuil, 8 km. distant.

THE Conseil Municipal of Arbois, the birthplace of Pasteur, has decided to erect a statue to his memory, and that henceforth the municipal college shall be called the Pasteur College.

THE first number of a new quarterly journal, '*Terrestrial Magnetism*,' is announced for January, 1896. It will be edited by Dr. L. A. Bauer, of the University of Chicago, with the coöperation of the leading students in America and Europe of terrestrial magnetism and allied subjects.

FRIEDRICH VIEWEG UND SOHN, Brunswick, have issued a list of their scientific publications which can doubtless be obtained on application to them. The catalogue extends to one hundred pages, and includes a large number of important works in the natural and physical sciences.

PROF. CHARLES S. MINOT, according to the *American Naturalist*, will give a special

course in vertebrate or human embryology at the Harvard Medical School. The course will run through two terms and is arranged for morphologists, anatomists and general practitioners who may wish to devote themselves chiefly to the study of these subjects for that length of time. The facilities offered by the Embryological Laboratory are unusually favorable both for the purposes of general study and of special research. Especial stress will be laid on laboratory work. The course will cover the whole field of embryology, "including the genital products, the theories of heredity and sex, the formation of the germ-layers, differentiation of the organs, the history of the placenta and the general morphology of vertebrates and of man."

A BUSINESS meeting of the Scientific Association of the Johns Hopkins University was held on October 17th, at which the following officers were elected for the current academic year: Ira Remsen, *President*; Wm. H. Howell, *Vice-President*; Charles L. Poor, *Secretary*.

THE Botanical Gardens of the University of Berlin are too small for the present requirements and will probably be removed to Dahlem, where some 125 acres will be provided. It is, however, feared that the distance of the Gardens from the other departments of the University will prevent their use by those who are not special students of botany. A Pharmaceutical Laboratory will be built at the Gardens.

THE new Museum of Toronto University was opened to the public for the first time on November 15th.

A RECEPTION was given to Lieut. Peary by the American Geographical Society and the American Museum of Natural History on November 14th, in the lecture hall of the Museum. Addresses were made by Lieut. Peary and Judge Daly.

A CABLEGRAM has been received from Dr.

Donaldson Smith announcing his safe return from his expedition in eastern Africa, where he has been engaged in explorations during the past eighteen months.

PROF. GEORGE LAWSON, a writer on chemistry and botany, and professor of these subjects in Dalhousie's College for thirty years, died at Halifax on November 10th.

Climate and Health for August gives the following vital statistics for the five weeks ending August 31st: In a population averaging 13,174,361, there were 25,746 deaths representing a death rate of 20.3 per thousand per annum. The mortality of infants under one year of age 33.3 per cent. of the total mortality and that of children between one and five years of age 14.2 per cent.

EXPERIMENTS are about to be undertaken by the Agricultural and Electrical Departments of the University of California to determine the feasibility of destroying phylloxera by electricity. It is hoped to succeed in doing this without injuring the vines.

IN addition to the regular courses given at Johns Hopkins University by Prof. William B. Clark and Dr. E. B. Matthews and Dr. R. M. Bagg, the following lectures have been arranged: Sir Archibald Geikie, Director General of the Geological Survey of Great Britain and Ireland, has accepted the invitation of the President and Board of Trustees to inaugurate the George Huntington Williams Memorial Lectureship, and has selected October, 1896, as the time for delivering his lectures. Mr. G. K. Gilbert will begin a course of lectures on Physiographic Geology the second week in January, and will lecture four times weekly until about the end of February. This course embraces a discussion of the origin of the forms of the earth's surface, and its treatment will include the systematic presentation of a large body of the principles of dynamic geology, especially those which apply to

the sculpture of the land by the various processes of erosion. The lectures will be illustrated by maps, models and lantern views. Mr. Bailey Willis will lecture twice a week during the months of March, April and May on Stratigraphic and Structural Geology. This course will consist of a description of the processes which result in the formation and upheaval of sedimentary rocks, and will lead to a discussion of the principles which should govern interpretation of the sedimentary record. In connection with these lectures Professor Cleveland Abbe will deliver four lectures on Climatology in its relations to Physiography. The lectures will given on January 6, 7, 8 and 9, 1896. The subjects are: 1. Sunshine and Temperature. 2. The Wind. 3. The Rain. 4. Snow and Ice.

THE Iceland Althing has requested the King of Denmark to communicate with other nations in regard to laying a cable from Iceland to the Continent. The resolution calls special attention to the importance of such a cable in the interests of meteorology.

ABOUT twelve of those who attended the Stirling County Ball on October 1st have since been seized with typhoid fever and three deaths have occurred. It is alleged that this resulted from eating contaminated oysters. At the opening meeting of the winter session of the Hull Scientific and Naturalists' Club, held on October 31st, Mr. Hollingworth, the President, delivered his presidential address on the artificial cultivation of edible molluscs. He said that in 1893 cholera broke out in 50 separate localities, attacking 287 persons, of whom 135 died; and out of these 50 localities, in 42 only single cases occurred, a circumstance hitherto unprecedented in the history of cholera, and pointing to special modes of infection. Of these cases 40 per cent. had eaten or handled shellfish within twenty-

four hours of being attacked, and in most cases the shellfish had come from the Grimsby and Cleethorpes beds. Cholera had been imported into Grimsby from abroad, and the position of the oyster, mussel and cockle beds of Grimsby and Cleethorpes was such that they might have been infected.

DR. PHILIPP BERTKAU, assistant professor of zoölogy at the University of Bonn, died on October 22d.

MACMILLAN & Co. announce for early publication 'The Child in Primitive Culture and Folk-Thought,' by Dr. Alexander F. Chamberlain, of Clark University. The subject will be treated under the following subdivisions: Names of the Child; Child and Mother; Child and Father; The Child in the Primitive Laboratory; The Bright Side of Child-Life; Childhood the Golden Age; Children's Food; Children's Souls; Children's Flowers and Plants; Children's Birds and Beasts; Child-Life in General; The Child as Factor in Society; The Child as Linguist; The Child as Actor and Inventor; The Child as Musician and Poet; The Child as Wiseacre, Oracle, Judge; The Child as Hero and Adventurer; The Child as Fetish, Divinity, God; The Christ-Child; Proverbs and Sayings about Children and Childhood. An extensive bibliography is appended.

It is stated in *Garden and Forest* that Dr. Chapman's herbarium of Southern plants, upon which is based his *Flora of the Southern States*, has been purchased by Mr. George W. Vanderbilt, and will serve as a nucleus of the scientific collections which he is establishing on his estate at Biltmore, in North Carolina, in connection with an arboretum and systematically managed forest.

UNIVERSITY AND EDUCATIONAL NEWS.

THE last Legislature appropriated a quarter of a million dollars to the Regents of

the University of California for the erection of a suitable building for the departments situated in San Francisco, the Colleges of Law, Medicine, Dentistry, Pharmacy and Veterinary Surgery. Adolph Sutro, Mayor of San Francisco, has given a tract of thirteen acres just south of and overlooking Golden Gate Park as a site for the building. On the adjoining thirteen acres Mr. Sutro proposes to erect a building for his magnificent library of about two hundred and fifty thousand volumes.

THE work in Physics at the University of California, formerly done by the late Prof. Harold Whiting, who lost his life by the foundering of the Colima, is now divided between Dr. E. P. Lewis, formerly assistant in physics at the Johns Hopkins University and associate professor of physics in the Columbian University, and Dr. A. C. Alexander, formerly assistant in physics at the Sheffield Scientific School.

MR. W. D. FROST, who has been assistant in the Laboratory of the Minnesota State Board of Health, has accepted a similar position in bacteriology in the University of Wisconsin.

DURING the summer an experimental laboratory in psychology has been fitted up at the University of Kansas. The work is in charge of Olin Templin, professor of philosophy.

THE University of Pennsylvania has received additional contributions to the dormitory fund amounting to \$40,000.

IT is stated that Charles Broadway Roush recently gave \$25,000 to the New York Association of the alumni of the University of Virginia, for the fund to replace 60,000 volumes of the university library recently destroyed by fire.

MR. HENRY LEWIS, A.R.S.M., has been appointed to the chair of mining in the Durham College of Science, which was recently vacated by Prof. Merivale.

LUMAN T. JEFTS, of Hudson, Mass., has given \$5,000 to Boston University to found a scholarship.

THE attendance in the Scottish universities for the year 1894-95 was: Edinburgh, 2,924; Glasgow, 1,903; Aberdeen, 812.

DR. JOHANNES GAD, professor of physiology in Berlin, has been called to the University of Prague, and Prof. Riedel, of Jena, has been called to the chair of surgery at Göttingen in succession to Professor König.

DURING the academic year 1894-95 the University of Leipzig granted the Ph. D. degré to 163 candidates.

THE Bavarian government has appropriated \$150,000 for the enlargement of the buildings of the University of Munich.

PROF. E. MACH, who has this year resigned a professorship of physics at Prague to accept the chair at Vienna vacated by the psychologist, Prof. Franz Brentano, gave an inaugural address on 'The Influence of Chance on the Development of Inventions and Discoveries.'

DISCUSSION AND CORRESPONDENCE.

THE INVERTED IMAGE ON THE RETINA.

TO THE EDITOR OF SCIENCE.—The discussion in recent numbers of SCIENCE concerning the inversion of the retinal image has occasioned me surprise, because I had supposed that the interpretation which has been familiar to me for many years had been universally accepted.

The interpretation is simply that we learn to associate the image with the correct position of the external object. Is it not the accepted view of psychologists that the primary conceptions of space are acquired by the child through touch and through its own movements connected with touch sensations? May we not look upon the visual sensations of external space relations as mental translations? If these two questions be answered affirmatively, then seeing objects right side up, despite the inversion of their retinal images, is a purely psycho-

logical and not a sensory phenomenon, and Prof. Le Conte's ingenious explanation becomes unnecessary.

In parenthesis, may I not ask whether since the rods and cones are inverted, *i. e.*, turned away from the light, would not Prof. Le Conte's 'push' produce an inverted sensation?

That the rectification of the retinal image is a matter of experience, will, I think, be readily believed by any one who has worked much with the microscope. The microscope also inverts the image, and when it is re-inverted in the eye it falls on the retina rightly placed, that is to say without inversion. A beginner finds it almost impossible to move a preparation under the microscope in the way he wishes, but with practice the coördination of sight and movement becomes so perfect that the adjustment is unconscious. Now suppose a child had inverted glasses kept permanently before its eyes, so as to correct the retinal inversion, would it not learn to adjust all its movements, just as microscopists learn to adjust one set of movements? In short would not that child think it saw everything right side up? Would it be conscious of any peculiarity in its visual conditions—of a great difference between it and all other children? I think, clearly not.

CHARLES S. MINOT.

HARVARD MEDICAL SCHOOL,
November 11, 1895.

SHELLS AS IMPLEMENTS.

EDITOR OF SCIENCE: Since writing about the pierced mussel shells of Florida and from the Shingu I have received a most obliging letter from Dr. Karl von den Steinen, in which he says: "On the Shingu they scrape wood with the pierced mussel *Anodonta*, while the Bororó of the Southern Lorenzo use the pierced *Bulinus* in their woodwork. Oars, handles of axes and other implements, bull roarsers and bows are rasped down and smoothed therewith. The objects are not put through the hole for polishing, but the mussel passes along them, the two edges of the hole operate alternately and greater accuracy of work and control over the implement are secured. The edge of the hole is not necessarily very sharp, neither does the workman retouch the edges as would the flint worker. He simply

throws the shell away, or makes another hole, as do the Bororó when it fails to work.

"They make the hole with the point of a palm nut, *acuri* on the Shingu *oaussá* on the Southern Lorenzo. Before making the hole they remove the outer part of the shell with the teeth." Dr. von den Steinen also sends drawings of the Payaqua mounted spoon, with small, smooth holes bored near the hinge to aid in the lashing. I should like my colleagues to note this interesting information in connection with the mussel shells of the Southern United States, having holes punched through them.

O. T. MASON.

A REPLY.

EDITOR OF SCIENCE—I note the criticisms in SCIENCE for November 1st, which my friend, Mr. Witmer Stone, has made upon my little book, 'A Naturalist in Mexico,' and I beg leave to answer the same through the columns of the same paper.

In the first place I wish to say that a foot note was prepared for pages 13, 80, etc., but which unfortunately did not appear in the published edition, and which was printed as follows upon a slip to be inserted in the volume. This slip was not, unfortunately, placed in the first fifty copies, and hence Mr. Stone's very just first criticisms:

ERRATA: For the account of the early discovery and conquest of Yucatan, and for the measurements of the ruins of Uxmal and Labna, the author is indebted to Stevens' 'Incidents of Travel in Yucatan.'

For the data used in the descriptions of the mountains, and for the identifications, and some notes on the birds, and of the land and fresh-water shells, the author is indebted to the papers of Messrs. Heilprin, Pilsbry and Stone, published in the Proc. Phil. Acad. Sci., 1890-5.

Our next point is the description of the different measurements of Orizaba, which were taken from Prof. Heilprin's paper as a matter of course, since the original papers from which he took them were not at my command. The error of measurement by Dr. Kaska with a 'thermometer' instead of barometer is a typographical error.

In regard to his next point I fail to see how my short description of the birds could well be

made different, since we both collected them together, I shooting as many as did he, and our notes were of course the same, and as he was the official ornithologist I very naturally drew on him for the correct data, since my work was given to him for his paper. If Mr. Stone will look back he will remember that we saw a large number of small birds about Col. Glenns' camp which we both thought were finches and thrushes. We actually obtained very few specimens, hardly enough to say that birds were or were not abundant, and our short stay at each point (half a day to a week) hardly warranted us in drawing too fine conclusions. In regard to the Trogan, I have a note of another bird which I saw in the cactus thicket which I believe was a Trogan, although I will not be certain of the fact. It is quite natural that the note books of two naturalists should vary. I am certain that my bird, which was *not* shot, had a 'rose-colored breast.'

In regard to the rarified atmosphere observed on Mt. Orizaba, I still affirm that "my head swam and my eyes became bloodshot" and my companion, Mr. Stone, *complained* of the same symptoms, and also of pain in the stomach. This my note book shows. The figure of *Tyrannus vociferus* was inadvertently made to represent *T. tyrannus* by my brother, who made the greater number of the drawings. I do not find that I state anywhere that the figures were drawn especially for this work.

Lastly, let me state that the accusation of plagiarism made by Mr. Stone is quite unjust, as I trust I have shown in this communication. The paper referred to by him (notes on the Round-tailed Muskrat) was of but 2½ pages, and when information was used from Mr. Chapman's paper, he was given due credit.

Of the thirty odd papers which have appeared under my name this is the first that has caused me to be accused of plagiarism. It seems a very late date to call up a paper written seven years ago, when some of my more recent papers might answer the purpose fully as well. Finally, let me state that every statement made in my little booklet has been written from notes taken on the day each incident happened, and at *no* time has my imagination been brought into play, nor have I depended upon my memory. If Mr.

Stone's notes vary from mine it is simply the very natural result of two persons taking notes independently. Mr. Stone's chief criticism seems to be the fact that his copy did not contain the reference slip of which I spoke. This I will send him. The real errors, of which there are many, will be corrected in a future edition.*

FRANK C. BAKER.

CHICAGO ACADEMY OF SCIENCES.

SCIENCE AND CYCLOPÆDIAS.

TO THE EDITOR OF SCIENCE—*Sir*: Unpleasant as it is to criticise any book, I think I am justified in asking you to publish a few words concerning the new edition of Johnson's Cyclopædia. It appears to me that science is treated so insufficiently that attention should be called to it.

An article of about five pages *against* the scientific truth known as 'Evolution' is included in Vol. III. I think the Johnson Company cannot give the names of three men of recognized scientific position who could be induced to write in opposition to evolution. But no article appears *against* 'homeopathy,' although the entire scientific world has condemned it.

In the department of biography, the names of Platt and Croker may be found; but Eimer, (Weismann's great opponent) Mendeléeff, Ecker, Bütschli, Horsley (Victor), Nägeli, and a host of other eminent men who have contributed towards our knowledge of nature's laws, are omitted.

'Chemotaxis,' 'actinomycosis,' 'appendicitis,' 'metalloid,' and 'metagenesis' are not mentioned in this new cyclopedia. As the last two words have been used with more than one meaning, it is especially important that reference books should contain them.

'Pannixia' is explained in *eleven* lines in the article in favor of evolution by Mr. Kingsley.

I have been unable to find one word concerning that destructive little insect, 'orgyia len-cosigma,' which must have interested many people for several summers past.

*I believe in exposing plagiarism wherever found, but do not see where that term can be applied to myself, in view of the facts which I have given. At the time my proof was read I was seriously ill with typhoid fever, and other parties corrected it.

The following evidence is offered with the object of showing by comparison that the space devoted to scientific subjects is utterly insufficient for the enlightenment of the general public.

| | |
|---|---|
| <p>'Degeneration' (two articles)—less than one and a-half columns.</p> | <p>'Pronunciation of foreign names' (exclusive of Latin and Greek names) over five columns.</p> |
| <p>'Parthenogenesis' one-half column, ending with 'the whole subject is obscure, however.' The reader is referred to Von Seibold, 'Parthenogenesis' and to Weismann, 'Essays on Heredity.' Both these works are far too technical to be intelligible to the general reader.</p> | <p>'Plattdeutsch' over four columns.</p> |
| <p>'Amphibia' one-half column.</p> | <p>'Pastoral Poetry' almost three columns.</p> |

Under 'Eclecticism' the reader is informed that a certain Dr. Newton founded the theory of cellular pathology and introduced antisepticism in surgery. The scientific world has given the credit of the former discovery to Virchow, and of the latter to Lister. Now I ask, for purposes of information, what did Robert S. Newton (whose biography is not given in Johnson's Cyclopaedia) write, or publish, upon cellular pathology, prior to the publication of Virchow's work in 1858? To credit anybody except Lister with the introduction of antisepticism is positively absurd.

'Monometallism' and 'bimetallism' are not to be found in this new cyclopaedia under the proper headings; indeed, there are not even cross-references to 'money.'

The Johnson Cyclopaedia is advertised by means of a sixteen-page circular, which bears neither publisher's nor author's name, a large part of it being devoted to abuse of what I have found a valuable, though by no means perfect, reference book, the *genuine* Encyclopaedia Britannica. The writer of this sixteen page advertisement wishes his readers to believe that one half of the Britannica is of no use to Americans, if it is to anybody. I understand that Messrs. Appleton never place their name upon advertising circulars criticising the publications of

other firms. I ask, in all fairness, is this honorable, or even reasonable?

I am not interested in any cyclopaedia, nor in any publishing house, and this letter would not have been written had I seen any detailed, impartial criticism of the Johnson Cyclopaedia.

LAWRENCE IRWELL.

BUFFALO, N. Y.

[Scientific subjects seem to be adequately treated in Johnson's Cyclopaedia. The circular mentioned by our correspondent is, however, very objectionable, and the Johnson Co. should take steps to prevent its further circulation. J. McK. C.]

SCIENTIFIC LITERATURE.

An Atlas of the Fertilization and Karyokinesis of the Ovum. By EDMUND B. WILSON, PH. D., with the coöperation of Edward Leaming, M. D., F. R. P. S. New York, Published for the Columbia University Press, by Macmillan & Co. 4to with ten plates. Price \$4.00.

This work is of a very high order, and both by its merit and its opportuneness is a noteworthy contribution to science. The basis of the work is Professor Wilson's able investigation of the early history of the ovum of one of our sea-urchins (*Toxopneustes variegatus*, Agassiz). The investigation was long and difficult, and its success is due in the first instance to the patient testing of many reagents until one was found which preserved the living organization of the ovum with a minimum of change. This reagent was a mixture of 80 parts of concentrated aqueous solution of corrosive sublimate and 20 parts glacial acetic acid. As the eggs are very minute, hundreds of them, all in the same stage, were imbedded at once, and sectioned together, leaving chance to determine that some of them be cut in favorable planes. The sections were made as thin as practicable, and were colored by Haidenhain's iron haematoxyline stain, also a reagent recently introduced. Of the many thousands, or perhaps hundreds of thousands of sections, the best have been sought out, and about two hundred of them photographed. From this collection of negatives, forty have been selected and reproduced as phototypes.

The photographs were all made by Dr. Edward Leaming, who in a prefatory note de-

scribes the photographic technique used. The pictures obtained represent the highest perfection of micro-photography yet reached, especially as applied to protoplasmatic structures. The reproductions are very good, but are not equal to the original negatives in delicacy and clearness.

The forty phototypes by themselves suffice to give a complete history of the maturation, fertilization and early segmentation of the ovum. Although they are less clear than many published drawings, these figures unquestionably take their place as the best we yet have, for their partial lack of distinctness is more than atoned for by their absolute accuracy and freedom from that element of personal interpretation which is unavoidable in every drawing, no matter how conscientiously made.

Each phototype is accompanied by a separate explanation of the details shown. This explanation, when necessary, is aided by diagrams inserted in the text.

To the whole is prefixed an abundantly illustrated 'General Introduction,' in which Professor Wilson gives a summary of our present knowledge of the history of the ovum, so far as it has any bearing on the problems of fertilization. It would be very difficult to surpass this introduction, owing to its felicitous combination of terseness, clearness and completeness.

The work takes its place at once as a classic, and is certainly one of the most notable productions of pure science which have appeared in America. It will be valuable to every biologist, be he botanist or zoologist, be he investigator or teacher. There will be many to congratulate the author upon his signal success.

CHARLES S. MINOT.

A Monograph of the Order of Oligochæta. FRANK EVERS BEDDARD. Oxford, Clarendon Press. 1895. New York, Macmillan & Co. 4°, pp. xii+769. 5 plates, 52 wood cuts.

Mr. Beddard's *Monograph of the Oligochæta* has been awaited with no little interest by naturalists, and is the third comprehensive work dealing with the earthworms and their allies. The older work of Vejdovsky (1884) was largely morphological in character and confined chiefly to forms studied by the author, while the exten-

sive work of Vaillant (1889-90) deals with the subject more from the systematic side, embracing descriptions of all known forms, but does not include references to literature published later than 1886. The present monograph is an attempt to bring together our knowledge of the entire subject up to the time of publication. It treats of both structure and systematic relationships and incorporates the large list of publications that have appeared during the last decade. No account, however, is given of the embryology of the group, owing, the author tells us in his preface, 'to Prof. Vejdovsky's recently [1889-90] published *Entwicklungs-geschichtliche untersuchungen*, which go into the matter with all details.' The author recommends this work to 'those who are desirous of ascertaining what is known about the embryology of the Oligochæta.' It is to be regretted that Mr. Beddard did not include the embryology in his general plan and give us a complete treatise on the Oligochæta. Even an abstract of Vejdovsky's work would have added greatly to the value of the volume for the English reader.

The work is divided into two parts, the first (pp. 1-155) dealing with the anatomy and geographical distribution; the second, or systematic portion, comprising classification, phylogeny and descriptions of genera and species. The anatomical portion treats more of the grosser anatomy, comparatively little space being given to histological matters. We miss more particularly an account of the finer anatomy of the nervous system, the knowledge of which has been enriched by the recent researches of Von Lenhossèk and Retzius. The part devoted to the discussion of the nephridia is, to our mind, the most complete in the morphological portion of the work.

The author divides the Oligochæta into three groups; (1) *Aphaneura*, (2) *Microdrili*, (3) *Megadrili*. The *Aphaneura* correspond to Vejdovsky's group of the same name, while the *Microdrili* and *Megadrili* are equal in value to the old divisions *Limicolæ* and *Terricolæ* of Claparède, with the exception that the *Aeolosomatidæ* are separated from the *Limicolæ* and constitute the first group or *Aphaneura*. The names *Microdrili* and *Magadrili* thus have a broader application than Benham's use of them. Among

the Microdrili the Lumbriculidæ, Tubificidæ and Naidomorpha are united into the superfamily Lumbriculides; the Perichætidæ, Cryptodriliidæ and Acanthodrilidæ constitute the superfamily Megascolicidæ among the Megadrili. The three groups include about 125 genera and 650 species, divided between thirteen families. Vejdovsky's family of the Chætogastridæ is abandoned, the genus Chætogaster being placed in the Naidomorpha, and no mention is made of the doubtful family of Discodrilidæ of the same author, with its single representative, the leech-like parasitic Branchiobdella, while the Criodrilidæ of Vejdovsky are absorbed by the Geoscolicidæ.

It is to be deplored that numerous inaccuracies occur. Many of these, no doubt, are due to careless proof-reading, but some are of a graver sort, and of a kind to shake the readers' confidence in the entire trustworthiness of the work. On page 110 we read that "there are as a rule but a single pair of glands [spermiducal glands] in the Megascolicidæ; but exceptions are known; thus with the exception of *Acanthodrilus monocystis* the Acanthodrilidæ have always two pairs opening onto the seventeenth and eighteenth segments," but Fig. 45 shows that in five species of Acanthodrilus the spermiducal gland pores lie in segments XVII and XIX; further in the definition of the genus Diplocardia (also an Acanthodrilid) we read page 548 'spermiducal gland pores on XVIII, XX.' Again in the definition of the genus Diplocardia we see 'setæ paired, absent from segment XIX on which lie the male pores,' and turning to the definition of Diplocardia communis we find 'male pores on XVIII, XX.' This is worse than confusing. Occasional inaccuracies as to authorities also occur; for example on page 314, where the genus *Distichopus* is accredited to Verrill instead of to Leidy.

Great praise is due to the author for the exhaustive bibliography he has collected, however we feel compelled to censure him for the way in which it is put together, and we claim a certain right to do this since he tells us, at the beginning of his bibliography, that 'with a few exceptions (marked with an asterisk) every quotation has been verified by myself.' To begin with, we consider dates in bibliographical refer-

ences to be of very great importance, but we find that only a very small percentage of the titles of the great list here given bear any date at all, and many of these are wrong. In addition to the omission of dates there are inaccurate details, the effect of which is to send one astray. One is not much aided by a reference without a date, to Vol. II., which should read Vol. XIX., as in Bergh (3); such references are unfortunately many. Again under Rosa (28) we are referred to 'ibid,' i. e., Ann. Mus. Civ. Genova, X., whereas the paper referred to appeared in Boll. Mus. Zool. Torino. II. T. Reichard appears for J. Reighard, and Lumbriculidæ for Lumbricidæ. Such slips are not confined to the bibliographical list; for example on page 711 we are referred to Rosa, Boll. Mus. Zool. Torino [no volume] 1872, when it should be twenty years later, in 1892. These examples are taken at random. There is no list of corrigenda. There is an index to genera and species only, and one is dependent upon a brief table of contents for other references. The imprint of the Clarendon Press is sufficient warrant for the typography and press work, which is of the highest order.

In conclusion, we would say that Mr. Beddard has undertaken a great task and has done it fairly well; he deserves the thanks of all students of the Oligochaets. A general synoptic key or table would have been a welcome addition for the student in the determination of species, while a careful revision of the manuscript would have made the book much more satisfactory. As it is, Mr. Beddard has given us an extremely valuable contribution to this branch of the Annelida.

W. McM. WOODWORTH.

FRANK SMITH.

A Manual of Qualitative Chemical Analysis, by E. P. HARRIS, PH. D., LL D., Professor of Chemistry in Amherst College. New Edition thoroughly Revised and Corrected. Amherst, Mass. 1895. 315 pages.

In most colleges the course in chemistry begins with lectures or recitations on the non-metals, generally combined with laboratory work, and this is followed by laboratory work in qualitative analysis. A question may be raised as to whether qualitative analysis is

the best medium through which to gain a knowledge of general chemistry either of the metals or the non-metals; indeed it is probable that the importance of qualitative analysis has been much over-estimated. It is of course necessary for those who intend to make a thorough study of the science, but the majority of college students do not pursue chemistry more than a single year, and it should not be difficult to devise a year's course in chemistry in which the student would gain far more knowledge of chemistry and more intellectual development than in the ordinary course, where such a large portion of the time is spent on qualitative analysis. There are dozens of laboratory manuals before us, in many, not to say most, of which the author's effort has apparently been to boil the matter down to the least possible space; the result has been the production of a series of more or less extended tables which the student follows blindly in searching for the contents of his unknown solutions, knowing nothing of the reasons for any step and gaining no knowledge of chemistry. Indeed, one may become a good analyst and know little of chemistry.

There are however teachers who use qualitative analysis as merely a medium of instruction in chemistry; who subordinate the acquisition of analytical skill to the acquisition of a knowledge of general chemistry and chemical theory. Such an one is the author of this book, and the present edition of his manual is the fruit of over three decades of laboratory teaching. The result is not a manual for self-instruction, but rather a guide to be used under the immediate supervision and instruction of a competent teacher.

The first half of the book is devoted to the reactions of the more common bases and acids, the students working with known solutions of a single salt and writing out each reaction on the blank pages with which this part of the book is interleaved. In this manner the student becomes familiar with these reactions, which represent all the ordinary ones used in qualitative and quantitative analysis. As he progresses in this work he is supposed to be furnished with solutions of unknown single salts for determination. This part is also intended to be supplemented by a course of lectures on

the metals and their compounds. The second part of the book is devoted to the systematic examination of solids. The method used here is that which was first introduced by the author and is now with greater or lesser modifications generally in use. It is safe to say, however, that little improvement has been made upon the original.

This is followed by qualitative separations. Here, while alternate methods are now and then given, the methods are generally confined to that one in each case which has proved itself best in the author's experience. There is a decided advantage in thus limiting the possible modes of procedure, as freedom of choice is confusing to the novice. Indispensable as Fresenius is to the advanced student, it is almost useless to the inexperienced.

A supplement gives fully the reactions of nearly all the rare elements, while a chapter in the appendix on the preparation of reagents will be useful to teachers. The earlier editions of the book have proved its success in the hands of no inconsiderable number of teachers beside the author, and this revised edition, which is a very considerable improvement on those which have preceded it, will be found even more valuable. If chemistry is to continue to be taught as largely through qualitative analysis as it has been in the past, this manual may safely be recommended as the best of its class. It is the writer's hope, however, that the day is not far distant when the improvement will be not along the old lines, but in the methods of chemical teaching themselves. The general style and make-up of the book is good, but it is unfortunately marred by poor proof-reading.

JAS. LEWIS HOWE.

WASHINGTON AND LEE UNIVERSITY,
LEXINGTON, VA., October 19, 1895.

La sensibilité de l'œil aux couleurs spectrales.
M. H. PARINAUD. *Revue Scientifique*, Sér. 4,
T. 4, 134—141. August 3, 1895.

In the *Revue Scientifique* for June 8, Parinaud described an interesting series of experiments on the relative sensibility of the adapted and unadapted eye to spectral colors.* In the issue of the same journal for August 3 he gives his

*See review in SCIENCE, II., 418, Sept. 27, 1895.

physiological deductions. The experiments brought out three important facts, namely, (1) adaptation (20-30 minutes stay in darkness) affects the sensibility for colors unequally. Beginning at zero for the red, the improvement increases as the wave-length shortens till for the violet it is very considerable; (2) adaptation does not make the colors seem more intense as colors, but only more luminous, as if white light had been added; and this may reach such a pitch with very faint lights that the colors are wholly lost in the white light; (3) the sensibility of the *fovea* is unaffected by adaptation.

On these facts Parinaud bases a theory of the rods and cones and the visual purple. In the *fovea* there are cones only, and, as everywhere, they are without purple. Adaptation appears to be an affair of the rods and the purple; it takes place where they are found, and fails where they are absent. Since the luminosity alone is affected, it is natural to regard them as an end-organ for luminosity only, leaving the cones to mediate color. The matter is not so simple, however, as a mere separation of the organs, for the cones must also mediate white, and, indeed, in Parinaud's opinion, could do nothing more than that without the coöperation of the cerebral centers. Hemeralopia (night-blindness), which appears to be due to a deficiency in the purple, confirms this theory of its function, as also does the good development of the rods and purple in the eyes of nocturnal animals. The purple is able to increase the effect of faint lights because of a fluorescent or phosphorescent property. Parinaud's arguments for such a property make a very plausible case. If he is correct the purple becomes an agent for the actual production of light on faint luminous stimulation instead of an agent for increasing the irritability of the visual apparatus. The paper concludes with a fairly full account of the work of other observers in related lines.* The contribution is important in bringing together a number of more or less disregarded facts and showing their very great physiological significance.

E. C. SANFORD.

*The reviewer hastens to withdraw his criticism of the first part of M. Parinaud's paper for deficiency in this respect.

Geology of the Green Mountains in Massachusetts.

By RAPHAEL PUMPELLY, J. E. WOLFF and T. NELSON DALE. Monograph XXIII of the United States Geological Survey. 1894. 4°. Pp. xiv, 206. Plates 23. Price \$1.30.

The monograph before us is the most detailed and valuable contribution yet made to the solution of the much debated 'Taconic question,' than which none other has achieved greater prominence or excited more bitter feeling in the last fifty years of American geology.

Since the discovery of actual fossils in the metamorphosed strata of Vermont by the Rev. Augustus Wing, the labors of many have indicated the true relations that are now demonstrated, yet nevertheless the difficulties of the problem were so great, and the tendency to generalize without detailed field work had been so marked, that Mr. Pumpelly and his co-laborers decided to throw aside all previous conclusions and by detailed and patient observation, based upon topographic maps in a crucial area, to trace out step by step the relations of these much disturbed and metamorphosed sediments. Accordingly the northwest corner of Massachusetts was selected and study was focused especially upon Hoosac Mountain on the east, Greylock Mountain on the west and the valley between. Hoosac Mountain, well known for the famous tunnel that penetrates it, is an anticlinorium with a core of granitic pre-Cambrian gneiss (the Stamford gneiss), on which rests, with conformable lamination, another variable white gneiss that is at times a recognizable conglomerated and even a quartzite (the Vermont formation). Above the last and still conformable is a great thickness of albite schist (the Hoosac schist), which is itself succeeded on the east by the Rowe schist. The Vermont formation is Cambrian; the Hoosac schist is Cambrian below, Silurian above. The Rowe schist is Silurian and of minor importance in the problem. On the west side of Hoosac Mountain the Hoosac schist fails and the Vermont formation runs under the Cambro-Silurian Stockbridge limestone that has been degraded to form the valley. It should be remarked that all the strata of Hoosac Mountain proper, except the Stamford gneiss, are metamorphosed *clastics*.

Greylock Mountain, with its spurs, is a

double synclinorium, whose lowest member is the Cambro-Silurian Stockbridge limestone. This is succeeded by the Berkshire schist, the Bellowspipe limestone and the Greylock schist, all Silurian. Now, the interesting geological thesis established by the monograph is that the metamorphosed clastics of the Hoosac Mountain are the shore deposits, which in the case of the Hoosac schist correspond to the deeper water, Stockbridge and Bellowspipe limestones and their accompanying schists. The determination throws a flood of light on the entire stratigraphy of the region, and simplifies the problem of the Green Mountains. The difficulties that were overcome in tracing out these metamorphic schists to their original sediments, in proving the uncomformability of the Vermont conglomerate gneiss upon the Stamford gneiss, when the foliation was the same in both, and the neat way in which it was done by the discovery of the eroded and depressed pre-Cambrian outcrop of a trap dike in the Stamford gneiss, which was buried under the Vermont formation, all called for patient study and close observation in the highest degree. And when the passage of the Hoosac schists into the Stockbridge limestone was finally established, a very hard problem was at last solved. The authors are to be warmly complimented and congratulated on their success.

Besides the stratigraphic results, many important contributions are made to our knowledge of the general metamorphism of sediments to crystalline schists.

The three authors were also aided in a degree calling for mention by Mr. B. T. Putnam, whose untimely death removed him in the midst of his career, and by Prof. W. H. Hobbs. The report is richly illustrated with that profusion of maps and plates which is only attainable in this country by attachés of the United States Survey. The investigations have been continued on the south by Professor Dale, whose later results are published in the Fourteenth Annual Report of the Director as reviewed in these columns, p. 632.

J. F. KEMP.

The Laccolitic Mountain groups of Colorado, Utah and Arizona. WHITMAN CROSS. 14th An-

nual Report of the Director of the U. S. Geological Survey, Washington, 1894. Pp. 165-241. Pt. ii.

Mr. Cross makes in this paper the second considerable contribution to our knowledge of laccolites, the first having been made by Gilbert in 1877. The West Elk Mountains, in Colorado, including Ragged Mount, Mt. Marcelina, the Anthracite range, Mt. Axtell, Mt. Carbon, Mt. Wheatstone, Crested Butte, Gothic Mount and probably others in the same group, are laccolitic in origin. So also are the San Miguel Mountains, about 70 southwest of the West Elk group. Still farther south, at a distance of 25 miles, the La Plata Mountains form a remarkable group of laccolites. About 65 miles farther south-west, in the northeastern corner of Arizona, lie the Carriso Mountains, the laccolitic nature of which is not positively stated. El Late Mountains, in the southwestern corner of Colorado, are believed to be laccolites. Next, the Abajo Mountains of eastern Utah are compared with the laccolites of the type area, and the La Sal Mountains, about 35 miles north of the Abajo Mountains, are only doubtfully considered as due to intrusions. In discussing the conditions of intrusion in laccolites, Mr. Cross concludes in agreement with Dana that Gilbert's explanation of the incoming of the magma into the strata is complete without reference to the relations which may exist between the densities of the lava and the stratified rocks.

Comment: The time of formation of laccolites and volcanoes in the same field seems not yet to be fully determined, but in two of the areas described it is probable that laccolites were first formed and subsequently dikes and volcanic rocks were formed, the former appearing at the present denuded surface and the latter having poured out upon the surface. If this order should prove generally true, it would agree with that observed in the case of small intrusions in the Boston basin. Thus in the slate area bordering the Mystic River there are at least three series of intrusions in the form of dikes and sills. The sills, here the analogues of laccolites, are in every instance connected with the earliest movements of the magma. Moreover, the sills came in before the

strata were well jointed, and at a time when the stratification planes were the leading lines of weakness. The dikes connected with the sills have irregular contact planes. The later dikes which cut the sills follow master joints. There is reason, in this field at least, for supposing that intrusion in the form of sheets took place, because the rock yielded more readily in a horizontal direction along the bedding planes than it did along vertical lines. But there is little in the mode of occurrence, or in the scale of these intrusions or the elevation of the strata above them, to afford a full comparison with the typical laccolites of the West.

In the review of the literature of laccolitic intrusions, an early account of a quaquaversal hill covering a domeshaped mass of trap in Derbyshire, England, seems to have been overlooked. The account and a cross-section will be found in Bakewell's Introduction to Geology, 2d Am. ed., New Haven, 1833, pp. 95-97.

J. B. WOODWORTH.

HARVARD UNIVERSITY.

Bibliography of North American Paleontology 1888-1892. By CHARLES ROLLIN KEYES. Bull. U. S. G. S., No. 121. 251 pp. Washington, 1894.

This publication will be received with welcome by paleontologists. Each separate paper appears under several subject headings, biologic, stratigraphic or geographic, so that the cross references make the list as good a substitute for a card catalogue as a printed list can be.

Several criticisms can, however, be made, for a close examination shows the work to be full of imperfections. Firstly, the compilation was carelessly done. This is evidenced in the careless copying of titles as well as in the omission from the list of nearly 150 papers published during 1888-1892, which is one sixth of the total number of papers appearing in the list under the authors' names. In many cases the titles are not given in full (as it is claimed they are in the introduction, p. 7).

Examples of such wrong copying are:

P. 229, second entry should be—Vodges, A. W. A Bibliography of Paleozoic Crustacea from 1698 to 1889, including a list of North

American species and a systematic arrangement of genera.

P. 70, seventh entry includes two separate papers by separate authors. They are—Dawson, J. William. Preliminary note on new species of sponges from the Quebec Group at Little Métis (Can. Rec. Sci. III, 49-59, figs. April, 1888). Hinde, George Jennings. Notes on sponges from the Quebec Group at Métis, and from the Utica Shale (Can. Rec. Sci. iii, 59-68. April, 1888).

P. 183, second entry should be—Ringuenberg, Eugene N. S. The Crinoidea of the Lower Niagara Limestone at Lockport, N. Y., with new species.

P. 190, third entry should be—Shaler, N. S. The Geology of the Cambrian District of Bristol county, Mass.

P. 108—Hollick, Alfred, should be—Hollick, Arthur.

P. 73, fourth entry should be—Hamilton, Chenango and Otsego counties, New York.

P. 73, third entry. 'Geology of Skunne-munk Mountain, Osage county, N. Y.,' should be; Geology of Skunne-munk Mountain, Orange county, N. Y. This title together and several others, though appearing under certain of the subject headings, are not entered under their author's names.

Pp. 21, 86, 198, 226. — 'Bison latiformis' should be *Bison latifrons*.

Pp. 30, 39, 42, 71.—The generic term *Clymenia* (a Cephalopod) appears as 'Calymene' (a Trilobite).

The proof reading is very bad, surprisingly so in a publication issued by the United States Geological Survey. The proof was read evidently by a person having no knowledge whatever of paleontological terms, for a large number of generic and specific names are incorrectly spelled. Some of the most unpardonable mistakes are 'Necomian,' 'Cheyene,' 'Ciasaurus,' 'Paneka,' 'Ceatopsida,' 'Foraminiferial,' etc.

P. 76, twelfth entry, 'Magia' probably means Niagara. The spelling in the species lists under titles of Matthew, G. F., is particularly bad.

The value of the publication would be greatly increased were the subject-matter printed on one side of each sheet only. This arrangement would enable the working paleontologist to

cut out the various items for pasting upon cards of his catalogue.

Appended are some of the more important papers which, though having appeared during the interim of 1888-1892, have not been listed by Mr. Keyes.

Ami, Henry M. Notes and Descriptions of some New and hitherto Unrecorded Species of Fossils from the Cambro-Silurian (Ordovician) Rocks of the Province of Ontario. *Can. Rec. Sci.* v, 96-103. April, 1892.

Ami, Henry M. Palæontological Notes I. On a Collection of Fossils from the Ordovician of Joliette in the Province of Ontario. *Can. Rec. Sci.* v, 104-107. April, 1892.

Ami, Henry M. Palæontological Notes II. On the Occurrence of Fossil Remains on the Manitou Islands, Lake Nipissing, Ontario. *Can. Rec. Sci.* v, 107-108. April, 1892.

Ami, Henry M. The Utica Terrane in Canada. *Can. Rec. Sci.* v, 166-183; 234-246. July and October, 1892.

Beecher, Charles E. On the Development of the Shell in the genus *Tornoceras*, Hyatt. *Am. Jour. Sci.* xl, 71-75, i. July, 1890.

Calvin, S. Some New Species of Paleozoic Fossils. *Bull. Lab. Nat. Hist. State Univ. Iowa*, i, 173-181, i-iii. June, 1890.

Dawson, J. Wm. On Sporocarps discovered by Prof. E. Orton in the Erian Shale of Columbus, Ohio. *Can. Rec. Sci.* iii, 137-140. July, 1888.

Hollick, Arthur. Additions to the Paleobotany of the Cretaceous Formation on Staten Island. *Trans. N. Y. Ac. Sci.* xii, 28-39, i-iv. Nov., 1892.

Hollick, Arthur. Paleobotany of the Yellow Gravel at Bridgeton, N. J. *Bull. Torr. Bot. Club*, xix, 330-333. Nov., 1892.

Hyatt, Alpheus. Jura and Trias at Taylorville, Cal. *Bull. Geol. Soc. Amer.* iii, 395-412.

Koken, E. Ueber die Entwickelungsgeschichte der Gastropoden vom Cambrium bis zur Trias. *Neues Jahrb. Min., etc.*, B. B. vi, 305-484, x-xiv. 1889.

Lapworth, Chas. On Graptolites from Dease River, B. C. *Can. Rec. Sci.* iii, 141-142. 1888.

Matthew, G. F. Illustrations of the Fauna of the St. John Group. No. vii. *Trans. Roy. Soc. Can.* x, Sect. iv, 95-109, pl. i. 1892.

Matthew, G. F. On the Diffusion and Sequence of the Cambrian Faunas. *Trans. Roy. Soc. Can.* x, Sect. iv, 3-16.

Scudder, Samuel H. Illustrations of the Carboniferous Arachnida of North America, of the orders Anthracomarti and Pedipalpi. *Mem. Bos. Soc. Nat. Hist.* iv, 443-456, xxxix-xl. 1890.

Scudder, Samuel H. The Insects of the Triassic Beds at Fairplay, Colo. *Mem. Bos. Soc. Nat. Hist.* iv, 457-472, xli-xlii. 1890.

Ulrich, E. O. Notes on Lower Silurian Bryozoa. *Jour. Cin. Soc. Nat. Hist.* Jan., 1890. Pp. 173-198.

Whitfield, R. P. Contributions to Invertebrate Paleontology. I. Descriptions of Fossils from the Paleozoic Rocks of Ohio. *Ann. N. Y. Ac. Sci.* v, 505-622, v-xvi. 1891.

Williams, Henry S. An account of the Progress in North American Paleontology for the years 1887, 1888. *Smithsonian Report for 1888.* Pp. 261-326. 1890.

GILBERT VAN INGEN.

SOCIETIES AND ACADEMIES.

BIOLOGICAL SOCIETY OF WASHINGTON, 248TH MEETING, SATURDAY, NOV. 2.

MR. F. V. COVILLE spoke of the botanical explorations of Thomas Coulter in Mexico and California.

Thomas Coulter, the Irish botanist, he said was born in the year 1793, near Dundalk, Ireland. He received his A. B. degree at Dublin University in 1817, and his A. M. in 1820. He then went to Geneva, where he studied for about three years under DeCandolle, and published a monograph of the Dipsacæ in 1823. In 1824 he sailed for Mexico, where for six years he made collections of plants at Real del Monte, Zimapan, Zacatecas, Hermosillo and presumably at intermediate points. In 1831 he reached Monterey, California, where he spent the winter with David Douglas, the Scotch botanist, and in the following Spring he made a journey from Monterey by way of San Luis Obispo, Santa Ynez, Santa Barbara, San Buenaventura, San Fernando, San Gabriel, Pala and San Felipe to a point on the Colorado River eight miles below its junction with the Gila, returning by

the same route. After making collections in other directions from Monterey, he returned to Europe by way of Mexico, reaching London in November, 1834, and bringing with him a collection of about fifty thousand herbarium specimens, besides a thousand woods and a complete journal of his travels and experiences. He presented his collections to Trinity College, Dublin, and thus became the founder and keeper of that well known herbarium. His journal was lost in transport between London and Dublin, and this together with his continued ill health kept him from publishing an account of his travels and work, which was thus left incomplete at the time of his death, in 1843. The duplicates of his collections were subsequently distributed in part by his successor, W. H. Harvey, at least two of the sets reaching America, one presented to Dr. Gray, the other to Dr. Torrey. Though no general report on his collections was ever published, a large number of species have been described from them, more than forty receiving the specific name *coulteri*. The information on which this outline was based was drawn principally from scanty published records together with a series of letters from Coulter to A. P. and Alphonse DeCandolle, which were exhibited at the meeting by Mr. Coville through the courtesy of Dr. Casimir DeCandolle, of Geneva.

Mr. William Palmer exhibited some specimens of birds having albinistic feet, saying that albinism of the beak and feet was rare, and that he had never seen an example of the former except in complete albinos. Partial albinism he thought to be due to temporary causes, such as defective nutrition, and he instanced cases in which white feathers had, upon moulting, been replaced by those normally colored.

Mr. F. A. Lucas spoke on the gigantic extinct birds of Patagonia, briefly reviewing Señor Ameghino's recent memoir on the subject. He considered that these birds belonged to an extinct avifauna, represented by a few forms like *Palamedea* and *Psophia*, and that many forms were needed to fill in the gap between them and existing birds. It was useless, he thought, to make any comparisons with struthious birds and he deprecated the use of the divisions *Ratitæ* and *Carinatæ* as being unnatural.

Dr. Theo. Gill spoke *On the Belone and Sarginos of Aristotle*, and the misuse of zoological names of the ancients by writers like Linnæus, dwelling at length on the *Belone* and *Sarginos*. The *Belone*, as is quite evident from the several passages wherein the name occurs, was the small pipe-fish, or Syngnathid, and its misapplication to the gar-fish was entirely unjustifiable. The gar-fish, however, was undoubtedly familiar to the ancients and the old Greek name can be discovered by a comparison of the name of unidentified species enumerated by Aristotle and those now current in Greece and the Archipelago. One of the hitherto unidentified Aristotelian names is *Sarginos*; and at the present time that name under a slightly different form still prevails and is applied to the gar-fish. The modern variants are *Zargana* and *Sargannos*. The application of *Belone* to the gar-fishes was unfortunate, but happily the name must be given up and *Esox* used in its place. *Esox* itself, however, is another example of misuse of ancient names, for the *Esox* mentioned by Pliny was apparently a sturgeon. The misuse of *Trochilus* and *Amia* was also dwelt upon.

Dr. Erwin F. Smith exhibited some plants showing the effect of inoculation with the organism of cucumber blight.

F. A. LUCAS, *Secretary*.

ENTOMOLOGICAL SOCIETY OF WASHINGTON.

THE 111th regular meeting was held November 7, 1895.

Mr. Hubbard read a paper entitled 'Some Insects which brave the dangers of the Pitcher Plant,' giving observations supplementary to those recorded 20 years ago by Riley, on the insects found in connection with *Sarracenia variolaris*. Mr. Hubbard's observations were made upon *S. flava*, a species common in Georgia and Florida. Mr. Hubbard found the larvæ of the two species of Xanthoptera described by Riley living unharmed in these pitchers. He found that an enormous number of insects were captured by the pitchers, among others the honey bee, species of *Bombus* and *Megachile*, sand wasps and many other insects. He found that a Sphegid makes its nesting place within the pitchers and that a species of *Lycosa* habitually spreads its web within them.

Sarcophaga sarraceniæ is so uniformly present and so abundant in every species of pitcher plant known to the speaker that he is constrained to think that the species has a more intimate connection with the economy of the plant than has been assigned to it.

Mr. Howard read a lengthy paper entitled 'Notes on the Life-history of *Culex pungens*, with remarks about other Mosquitoes.' He gave results of actual rearing of *C. pungens* in Washington, showing that a generation may develop in ten days. Other mosquitoes occurring at Washington are *Psorophora ciliata* and *Anopheles quadrimaculatus*. The subject of mosquito remedies was treated in extenso. The paper was discussed by Messrs. Gill, Marlatt, Ashmead, Hubbard, Mann and Benton.

Mr. Heidemann exhibited specimens of the winged form of *Rheumatobates rileyi* and *R. tenuipes*. These specimens were of especial interest since Meinert doubts the existence of winged individuals.

Mr. Ashmead exhibited certain Mutillidæ and called particular attention to the differences between *Sphærophthalma* and *Photopsis*, expressing himself as of the opinion that one section of the genus *Photopsis* is based entirely on males of *Cyphotes*.

Mr. Hubbard exhibited a brood cell of what is probably *Xyleborus pini*, announcing the discovery that this insect in its brood cell constructs a cemetery for dead larvæ and adults, removing them entirely from the main portion of the cell in which grows the ambrosia upon which the larvæ feed. He compared the intelligence exhibited in this way with that shown by ants, since certain of the latter insects cultivate fungi and similarly set aside spots to be used for cemeteries.

L. O. HOWARD, *Recording Secretary*.

NEW YORK ACADEMY OF SCIENCES.

THE Academy met on October 28, with Vice-President Stevenson in the chair. After the usual routine business the Geological Section organized and listened to the following paper:

Geological notes from Long Island and Nantucket by Arthur Hollick. The author described the further discovery of fossil Cretaceous plants at Center Island in Oyster Bay, along the north shore, and on Montauk Point, the

northeastern extremity. He also mentioned the finding of several boulders containing marine Cretaceous molluscs, and set forth the reasons for thinking that the New Jersey greensands had formerly existed in the basin of Long Island Sound. Recent observations and lists of fossils from Sankaty Head, Nantucket, concluded the paper. Among these was a fragment of silicified Palm-wood, the first specimen of the kind recorded from eastern North America. Discussion followed by W. M. Davis.

The second paper was by Gilbert Van Ingen and T. G. White: "An account of geological work the past summer on Lake Champlain." The paper described the results of recent stratigraphical studies on the Trenton limestones and briefly outlined the character and relations of the faunas. An abstract will appear in the Transactions of the Academy of even date.

After routine business on November 4 the Section of Astronomy and Physics organized, and listened to a paper, by Prof. R. S. Woodward, upon 'Systems of Mechanical Units.' Mr. Woodward referred to the importance of the dimensional formulæ in discussing systems of units, and called attention to their introduction in 1821 by Fourier, and their subsequent revival by Maxwell. He pointed out some of the difficulties arising from the adoption of the present fundamental units of length, mass and time, and showed how, by the elimination of either length or time and the substitution of energy, new systems could be obtained. He dwelt upon the desirability of the system in which energy replaces time for those people who may have no conception of time, and pointed out that the conceptions of energy are certainly as distinct as those of mass and possibly even as distinct as those of length and time. This paper was discussed by Profs. Pupin, Hallock and Pfister.

Prof. Harold Jacoby then read a paper received too late for announcement in the Bulletin, on 'Suggestions as to the determination of the relative mass of the two components of the double Star Eta Cassiopeiæ,' from Rutherford photographic measures. Prof. Jacoby outlined the method to be pursued in this investigation, and deduced the formulæ to be used. The

calculations will be made by Mr. Davis. The paper was discussed by Prof. Rees.

Prof. Pupin then explained a method of measuring alternating currents with a galvanometer. It consists in placing in the circuit a primary cell and an electrolyte cell whose counter electro-motor is slightly greater than that of the primary cell. Under these conditions only one-half of the alternations passed through the circuit, the other half being stopped by the two cells. Experiments have shown the availability of this method up to 600 alternations per minute.

J. F. KEMP, *Secretary*.

GEOLOGICAL CONFERENCE OF HARVARD UNIVERSITY, OCTOBER 22, 1895.

The Development of Oligoporus. By ROBERT T. JACKSON.

The following is an abstract of the results of recent studies of the Palæoechinoidea. In Oligoporus the interambulacra terminate ventrally in two plates, which present on their oral faces a reëntrant angle for the reception of a single initial plate of the area. Proceeding dorsally, new plates and new columns of plates are added, accenting by their appearance stages in growth, as he had previously shown in Melonites, until the full complement of the species is attained. The single initial interambulacral plate of Oligoporus was compared with a similar plate in Melonites, Lepidechinus, young modern Cidaris, etc. At the ventral or younger portion of the corona of Oligoporus there are only two columns of ambulacral plates. The four columns characteristic of the adult are derived from these two by a drawing-out process. The four columns of ambulacral plates of adult Oligoporus are the equivalent of the two outer and two median columns of Melonites. These four columns in both genera are the morphological equivalent of the two columns seen in the ambulacra of Bothriocidarid, Cidarid, etc.

Oligoporus, as shown by the development of both ambulacral and interambulacral areas, is a genus intermediate between Palæechinus and Melonites. During the development of Oligoporus it passes through a Rhæechinus stage, and later a Palæechinus stage. Melonites in its development passes through an Oligoporus stage.

An early stage in developing Echinoderms was named the 'protechinus' stage. At this stage are first acquired those features which characterize the developing animal as a member of the Echinoidea. The protechinus stage in Echinoderms is directly comparable to the protoconch of Cephalous Mollusca, the protogulum of Brachiopods, the protaspis of Trilobites, etc. The Echinoderm at this period in its growth has a single interambulacral plate (representing a single column of such plates), and two columns of ambulacral plates in each of the five areas. This stage is seen in Oligoporus, Lepidechinus, Goniocidarid and other genera; it finds its representative in an adult ancestral form, in the primitive, oldest known genus of the class, Bothriocidarid, of the Lower Silurian, which has but one column of interambulacral and two columns of ambulacral plates in each area.

Species of Oligoporus and Melonites with few interambulacral columns are considered the more primitive types, as they are represented by stages in the development of those species which acquire a higher number of columns in the adult.

The structure of the ventral border of the corona of Archæocidarid was described. It presents a row of plates partially resorbed by the encroachment of the peristome, as in modern Cidarid, etc. Ambulacral and interambulacral plates on the peristome were described in Archæocidarid, also teeth and secondary spines on the interambulacral plates of the corona.

This paper contains a classification of Palæozoic Echini based on the structure and development of the ambulacral and interambulacral areas and the peristome. It will be published in the Bulletin of the Geological Society of America.

Tidal Sand-cusps. F. P. GULLIVER.

In the rias, or drowned valleys, of the Puget sound region, Washington, occur many cusped deposits of sand projecting from the valley sides into the tidal inlets. West point, north of Seattle, is the typical example (Coast Survey, 653; Geological Survey, Seattle sheet). These points always project at right angles both to the shoreline and to the general direction of in and out flowing tidal currents. They vary in stage

of development from an early condition of a V-shaped bar inclosing a lagoon, similar to the bars described by Mr. Gilbert on the Bonneville shoreline (Mon. I., U. S. G. S. 1890, 58), to the stage where the lagoon has been filled and the marsh covered with sand dunes. These sand cusps were not produced by ocean eddy currents as in the case of Hatteras, Look-out, etc. (C. Abbe Jr., B. Soc. Nat. Hist., XXVI., 1895, 489-497). Along the outer shoreline the ocean currents with large radii of curvature are effective, but upon the inner shore line the tidal currents are the more important agents. The terms inner and outer are adapted from those used by Prof. Penck in *Morphologie der Erdoberfläche*, 1894, II., 551.

An ideal scheme of inflowing tide with its eddies is given in the figure. The outflowing tide

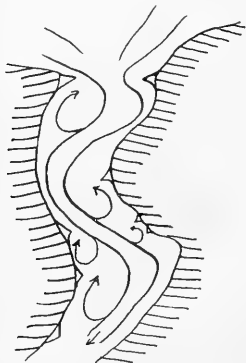

would reverse the direction of flow and transportation of shore drift.

Other examples of similar cusps whose formation has been referred to tidal action are those on Coatue beach, Nantucket (N. S. Shaler, Bull. U. S. G. S., No. 53, 1889, 13), and Romney marsh in southeast England (W. Topley, *Geol. of the Weald*, 1875, 211, 303). This material was presented as a portion of a thesis to be published at a later time.

MEETING OF OCTOBER 29, 1895.

Some Features of the Arizona Plateau. L. S. GRISWOLD. Illustrated by stereopticon.

The district here considered includes parts of northeastern Arizona; the middle portion of the valley of the Little Colorado, the region about the San Francisco Mountains, and a portion of the Grand Cañon of the Colorado, being the localities best observed.

In general the plateau surface is between 5,000 and 7,000 feet in elevation above sea level and strikes one as being remarkably smooth for so high elevation; there are large stretches of nearly level or gently rolling country, diversified, however, by mesas and outliers with escarpments rising between 50 and 200 feet, shallow but broad old stream channels now little used and leading to cañons with precipitous walls. On the plateau top are numerous volcanic elevations, varying in age from the young cinder cone to the denuded stock. Over the district silicified wood is well known, occurring at the base of a gravel and sand horizon, little consolidated, belonging to late Tertiary or Pleistocene times, and lying with slight unconformity in part upon probable Triassic strata and in part upon Carboniferous, the older formations being little disturbed.

The trees now petrified, originally grew to large size, eight or nine feet in diameter for the largest, probably conifers, and perhaps not very different from the forest growth of part of the present plateau. This ancient forest was apparently thrown down by the wind, for tree butts are common in horizontal position, while only one was found erect. The gravel and sand covering would seem to have come soon, for only a few have fillings of sediment in hollows or give other indication of decay; the logs were buried at least fifty or sixty feet deep. The weight of the overlying sediments crushed the trees so that the horizontal diameters are commonly greater than the vertical as they are seen in place. Silicification was probably accomplished by percolating surface waters, as the logs are distant from volcanic vents, as far as known to the writer; then no hot water deposits were seen accompanying the logs, and the distribution as seen over many miles and reported much more widely would also militate against the theory of change by hot waters.

The stages noted in the development of the plateau would begin with a baselleveling of the

older formations, Carboniferous-Triassic; in late Tertiary or early Pleistocene times a forest growth was apparently thrown down and soon covered by coarse sediments, after which percolating waters replaced the vegetable matter with silica. The existence of the widespread gravels necessitates belief in an equally widespread plain in late Tertiary or Pleistocene times. An uprising of perhaps a few hundred feet gave opportunity for wearing away the gravels and the upper part of the older formations, and the valley systems broadened and interlocked to produce mesas and outliers, while streams gained a meandering habit to some extent. A second and great uplifting to the present plateau altitude gave opportunity for the greater drainage lines to cut deep trenches with precipitous sides. The subordinate drainage in the Carboniferous limestone region seems to reach the cañon bottoms chiefly by underground channels, the old surface valleys showing small traces of recent work, while on the other hand the development of sink holes has begun. In the sandstone and shale regions the water in part goes underground to the main channels; in part it is carving the plateau surface by a system of 'box cañons.'

The volcanic work would appear to have begun after denudation of the Tertiary or Pleistocene plain had progressed far, but before the second or cañon elevation; the large number of volcanic masses in all stages of destruction evinces a pretty continuous activity until perhaps the last few centuries.

THE ACADEMY OF SCIENCE OF ST. LOUIS, MO.,
NOVEMBER 4, 1895.

THE Academy held its regular meeting with President Green in the chair and thirty-three members and visitors present.

Prof. Francis E. Nipher, as a committee appointed by President Green, read a memorial of the late Prof. C. V. Riley, dwelling briefly upon Prof. Riley's life and work, and especially his great achievements in the field of economic Entomology.

Prof. H. S. Pritchett presented a communication on 'The Resumé of Certain Studies of the Satellite System of Saturn,' calling attention to the remarkable similarity between this

system and the solar system, and also the frequent eclipses to which the satellites of Saturn are subjected.

A very interesting exposition was given of the effect of the attraction of the large satellite Titan upon the smaller Hyperion, resulting in great eccentricity of the orbit of Hyperion and a rapid revolution of its pericentric. Mention was also made of the curious phenomena of the satellite Iapetus being much brighter on one side than on the other, and of its revolution on its axis coinciding with its revolution around the planet.

The paper was followed by a discussion as to the nature of the Saturnian system of rings and satellites.

Prof. Nipher presented a paper on 'The Law of Minimum Deviation of Light by a Prism.'

Adjourned.

A. W. DOUGLAS,

Recording Secretary.

SCIENTIFIC JOURNALS.

JOURNAL OF GEOLOGY, OCTOBER-NOVEMBER.

On the Cliffs and Exotic Blocks of North Switzerland: By E. C. QUEREAU. Certain exotic rock masses occurring along the north border of the Alps and Carpathian mountains have long been more or less a puzzle to geologists. They occur on the Flysch, which is Eocene, while the fossils found in the cliffs have been pronounced by Professors Kaufmann, Steinmann and the author to be Jurassic. Two explanations have been offered for the phenomenon: First, that the cliffs were forced up through the newer rocks. Second, that they were thrust over them. Of these hypotheses the author maintains the latter. He finds the source to the north in a mountain system 'das Vindelische Gebirge,' now buried under the Miocene of the Swiss plain, the existence of which was predicated on entirely different grounds by Professor Studer and other Swiss geologists.

The Preglacial Valleys of the Mississippi and its Tributaries: By FRANK LEVERETT. That drainage systems were greatly changed by the advance of the ice is no longer doubted. The author has in this paper gathered a large amount of data with reference to preglacial

drainage lines in the north part of the Mississippi basin, in the hope that such facts may lead to inferences concerning the preglacial altitude of the region, differential crust movements, the effect of glaciation in enlarging and deepening valleys and other questions relating to glacial influence.

The Classification of the Upper Paleozoic Rocks of Central Kansas: By CHAS. S. PROSSER. This is the concluding portion of the paper begun in the last number of the *Journal*. It gives a detailed study of the paleozoic series from the Waubesa beds of the author in the U. Coal Measures to the Marion beds in the Permian. The paper is a valuable contribution to the stratigraphy of Kansas and its value is enhanced by the table of formations accompanying.

The Volcanics of the Michigan District of Michigan: By J. MORGAN CLEMENTS. These rocks are Huronian in age and lie to the west of the Archean core between Bone Lake on the north and Crystal Falls on the south. They have a thickness of about 4,000 feet and vary in character from melaphyre and porphyrite to quartz-porphry and devitrified rhyolites called aporhyolites. As a result of his study of this series, the author confirms the conclusions of many late investigators regarding the identity of these older volcanics with modern lavas and proposes to name them accordingly..

The Influence of Debris on the Flow of Glaciers: By ISRAEL C. RUSSELL. The principle maintained is that the flow of a glacier under given conditions will depend on the percentage of debris mingled with it and will be least when that percentage is greatest. This principle is applied in explaining the irregularities of glacial erosion and deposition, such as subglacial gravel deposits, the formation of complex terminal moraines and the difficult subject, the origin of drumlins. He sees no good reason why we may not have drumlins of sand, loess or gravel, as well as till.

Glacial Studies in Greenland No. VIII: By T. C. CHAMBERLIN. This is mainly a description of the Krakokta glacier which descends northerly from the Redcliff peninsula. The relations of this glacier to its moraine are followed with some detail. Where it meets the Tuktoo glacier moving southward, a joint moraine is produced,

which perhaps is medial in position, but terminal in nature. At some places the ice lies well within its moraine, and at others the moraine is completely overridden by recent advances of the ice. The photographs illustrate these points as well as the regular and beautiful stratification of the glacier and its freedom from debris, except in the lower portion.

The Editorial: By R. D. SALISBURY gives a condensed account of the Peary Relief Expedition of the present summer, and of the results, geological and otherwise, of Mr. Peary's work during two seasons in Greenland.

Reviews are contributed by J. P. Iddings, T. W. Stanton, S. Weller and T. C. Hopkins.

NEW BOOKS.

Die Artbildung und Verwandtschaft bei bei den Schmetterlingen (Part 2). DR. G. H. THEODOR EIMER. Jena, Gustav Fischer. 1895. Pp. 153.

A Handbook of British Lepidoptera. EDWARD MEYRICK. London and New York, Macmillan & Co. Pp. vi.+843. \$325.

Notes on the Nebular Theory. WILLIAM FORD STANLEY, London, Kegan Paul, Trench, Trübner & Co., Ltd. 1895. Pp. xv.+259.

Problems in Differential Calculus. W. E. BYERLY. Boston and London, Ginn & Co. 1895. Pp. vii+71.

The Production of Iron Ores in Various Parts of the World. JOHN BIRKENBINE. Washington. 1895. Pp. 204.

A Handbook of Industrial Organic Chemistry. SAMUEL P. SADTLER. Second Edition. Philadelphia and London, J. B. Lippincott & Co. 1895. Pp. xvii+537.

The Structure and Development of Mosses and Ferns. DOUGLAS HOUGHTON CAMPBELL. London and New York, Macmillan & Co. 1895. Pp. viii+554. \$4.50.

Laboratory Manual of Inorganic Preparations. By H. T. VULTÉ and GEO. M. S. NEUSTADT. New York, Geo. Gottsberger Peck. 1895. Pp. ii+180+iii. \$2.

Indianische Sagen von der Nord-Pacifischen Küste Amerikas. FRANZ BOAS. Berlin, A. Asker & Co. 1895. Pp. vi+363.

SCIENCE

NEW SERIES.
VOL. II. No. 48.

FRIDAY, NOVEMBER 29, 1895.

SINGLE COPIES, 15 CTS.
ANNUAL SUBSCRIPTION, \$5.00.

GUSTAV E. STECHERT'S

Recent Importation of Scientific Books.

APEL, DR. MAX. Kants Erkenntnistheorie u. seine Stellung zur Metaphysik. Eine Einführung in d. Studium von Kants Kritik der reinen Vernunft. 147 Seiten. 8^o. Mk. 3⁰⁰.

BAAS, J. HERM. Die geschichtliche Entwicklung des ärztlichen Standes u. der. medizinischen Wissenschaften. Mit 2 Abbildgn. 480 Seiten. gr. 8^o. Mk. 11⁰⁰.

BREDERMANN, W. Electrophysiologie. 2^{te} Abtheilung. Mit 149 Abbildungen. 857 Seiten. gr. 8^o. Mk. 9⁰⁰.

BUCHKA, DR. KARL VON. Physikalisch-chemische Tabellen der anorganischen Chemie. 348 Seiten. gr. 8^o. Mk. 10⁰⁰.

FUCHS, DR. GOTHOLD. Anleitung zur Molekular-gewichtsbestimmung nach der 'Beckmannschen' Gefrier- u. Siedepunktmethode. Mit 18 Text Figuren. 14 Seiten. Cloth. M. 1⁵⁰.

GERARD, ERIC. Mesures électriques. Leçons professées à l' institut electrotechnique 'Montefiore annexé à l' université de Liège, Avec 198 figures dans le texte. 457 pages. Cloth. Francs 12⁰⁰.

GOMPERZ, THEOD. Griechische Denker. Eine Geschichte der antiken Philosophie. 1^{ster} Band. 478 Seiten. gr. 8^o. Mk. 10⁰⁰.

GRUNMACH, DR. LEO. Lehrbuch der magnetischen u. electrischen Maassheiten, Messmethoden u. Messapparate. Mit 342 in den Text gedr. Holzschnitten u. vielen Tabellen. 632 Seiten. Mk. 16⁰⁰.

HAMMARSTEN, OLOF. Lehrbuch der physiologischen Chemie. 3^{te} völlig umgearb. Auflage. Mit Spectral tafel. 647 Seiten. gr. 8^o. Mk. 14⁰⁰.

KIPPENBERGER, DR. KARL. Beiträge zur Reinsolirung, quantitativen Trennung u. chemischen Charakteristik von Alkaloiden u. glycosidartigen Körpern in forensen Fällen, mit besonderer Rücksicht auf den Nachweis derselben in verwesenden Cadavern. 58 Seiten. 8^o. Mk. 1⁰⁰.

KISSLING, P. B. Beiträge zur Kenntniss des Einflusses der chemischen Lichtintensität auf die Vegetation. 28 Seiten. gr. 8^o, mit 3 Platten. Mk. 3⁰⁰.

KRATZER, DR. JUL. Der Tod durch Electricität. Eine forensisch-medicin. Studie auf experimenteller Grundlage. Mit 7 Abbildgn. und Tafeln. 159 Seiten. gr. 8^o. Mk. 7⁰⁰.

LE BLANC, DR. MAX. Lehrbuch der Electrochemie. Mit 32 Figuren. 226 Seiten. 8^o. Mk. 4⁸⁰.

LEVY, S. Anleitung zur Darstellung organisch-chemischer Präparate. 3^{te} neu bearbeitete u. erweiterte Auflage herausg. v. Dr. A. Bistrzycki. Mit 35 in den Text gedr. Holzschnitten. 210 Seiten. 8^o. In paper, Mk. 4⁰⁰; in cloth, Mk. 5⁰⁰.

MÜLLER, E. Die vermeintlichen Inductionsstörungen im Fernsprechbetriebe u. deren Bedeutung. 65 Seiten. 8^o. Mk. 2⁴⁰.

NERNST, W. U. A. SCHÖNFLIES. Einführung in die mathematische Behandlung der Naturwissenschaften. Kurzgefasstes Lehrbuch der Differential- u. Integralrechnung mit besonderer Berücksichtigung der Chemie. Mit 61 im Text befindl. Figuren. 309 Seiten. gr. 8^o. Mk. 8⁰⁰.

OSTWALD, WILH. Die Ueberwindung des wissenschaftlichen Materialismus. Vortrag, gehalten i. d. Versammlung d. Naturforscher u. Aerzte zu Lübeck am 20^{ten} September, 1895. 36 Seiten. 8^o. Mk. 1⁰⁰.

PAULSEN, DR. FRDR. Geschichte des gelehrten Unterrichts auf den deutschen Schulen u. Universitäten vom Ausgange des Mittelalters bis zur Gegenwart. 2^{te} umgearb. u. sehr erweiterte Aufl. 1^{ster} Halbband. 320 Seiten, gr. 8^o. Mk. 7⁰⁰.

PLÜCKERS, JULIUS. Gesammelte wissenschaftl. Abhandlungen. Im Auftrage d. Kgl. Gesellschaft d. Wissenschaften zu Göttingen, herausgegeben v. A. Schönflies und Pockels. 1^{tes} Band. Mathematische Abhandlungen, herausgegeben von A. Schönflies. Mit einem Bildniss und 73 Figuren. 620 Seiten. gr. 8^o. Mk. 20⁰⁰.

PREYER, W. Die Seele des Kindes. Beobachtungen über die geistige Entwicklung des Menschen in den ersten Lebensjahren. 4^{te} Aufl. 462 Seiten. 8^o. Mk. 8⁰⁰.

SMITH, DR. AUGUST. Die Alkoholfrage u. ihre Bedeutung für Volkswohl u. Volksgesundheit. Eine social-medicinische Studie für Aerzte u. gebildete Laien. Mit 7 Abbildungen. 127 Seiten. 8^o. Mk. 2⁸⁰.

SRAUPL, DR. ALEX. Erläuterungen zur qualitativen Analyse anorganischer Körper in Bezug auf die practischen Hilfsmittel u. den planmässigen Gang derselben. Mit 50 Abbildgn. im Text. 173 Seiten. 8^o. 3⁰⁰.

WEHMER, DR. C. Beiträge zur Kenntniss einheimischer Pilze. Experimentelle Untersuchungen auf dem Gebiete der Physiologie, Biologie u. Morphologie pilzlicher Organismen. II. Theil. Mit 3 Tafeln u. 6 Tabellen. 184 Seiten. gr. 8^o. Mk. 7⁹⁰.

GUSTAV E. STECHERT,

810 Broadway, New York

Macmillan & Co.'s Recent Publications.

Essays in Taxation.

By EDWIN R. A. SELIGMAN, Professor of Political Economy and Finance, Columbia College. 8vo, cloth, pp. x, 434. Price, \$3.00 net.

The Law of Civilization and Decay.

An Essay on History. By BROOKS ADAMS. 8vo, cloth, \$2.50.

The Beginning of the Middle Ages.

By the Late R. W. CHURCH, M. A., D. C. L., Sometime Dean of St. Paul's, Rector of Whatley, Fellow of Oriel College. 12mo, cloth (Eversley Series), \$1.50.

Acton.—A Lecture on the Study of History.

Delivered at Cambridge, June 11, 1895. By LORD ACTON, LL. D., D. C. L., Regius Professor of Modern History. 12mo, cloth, 75 cents.

Herodotus.—The Fourth, Fifth and Sixth Books.

With Introduction, Notes, Appendices, Indices. Maps by REGINALD WALTER MACAN, M. A., Fellow and Tutor of University College, Oxford, and University Reader in Ancient History. Vol. I., *Introduction, Text with Notes*. Vol. II., *Appendices, Indices and Notes*. 2 vols., 8vo, cloth, \$7.50 net.

Browning Studies.

Being Select Papers by Members of the Browning Society. Edited with an introduction by EDWARD BERDOE, M. R. C. S., author of "The Browning Cyclopaedia," etc. 8vo, cloth, \$2.25.

Century Science Series.

Edited by SIR HENRY E. ROSCOE, D. C. L., F. R. S.

NEW VOLUME.

Lyell.—Charles Lyell and Modern Geology. By PROF. T. G. BONNEY, D. Sc., LL. D., F. R. S., etc. With Portrait. 12mo, cloth, \$1.25.

Tait.—Dynamics.

By P. G. TAIT, M. A., Sec. R. S. E., Honorary Fellow of St. Peter's College, Cambridge, Professor of Natural Philosophy in the University of Edinburgh. 12mo, cloth, \$2.50 net.

Menschutkin.—Analytical Chemistry.

By N. MENSCHUTKIN, Professor in the University of St. Petersburg. Translated from the Third German Edition, under the supervision of the author, by James Locke. 8vo, cloth, \$4.00 net.

Meyrick.—A Handbook of British Lepidoptera.

By EDWARD MEYRICK, B. A., F. Z. S., F. E. S., Assistant Master of Marlborough College. With Illustrations. 12mo, cloth, \$3.75.

MACMILLAN & CO., 66 Fifth Avenue, New York.

SCIENCE

EDITORIAL COMMITTEE: S. NEWCOMB, Mathematics; R. S. WOODWARD, Mechanics; E. C. PICKERING, Astronomy; T. C. MENDENHALL, Physics; R. H. THURSTON, Engineering; IRA REIMSEN, Chemistry; J. LE CONTE, Geology; W. M. DAVIS, Physiography; O. C. MARSH, Paleontology; W. K. BROOKS, Invertebrate Zoology; C. HART MERRIAM, Vertebrate Zoology; S. H. SCUDDER, Entomology; N. L. BRITTON, Botany; HENRY F. OSBORN, General Biology; H. P. BOWDITCH, Physiology; J. S. BILLINGS, Hygiene; J. MCKEEN CATTELL, Psychology; DANIEL G. BRINTON, J. W. POWELL, Anthropology.

FRIDAY, NOVEMBER 29, 1895.

CONTENTS:

| | | |
|--|---------------------|-----|
| <i>Meteorology in the University:</i> | CLEVELAND ABBE..... | 709 |
| <i>Geologic Atlas of the United States</i> | | 714 |
| <i>American Fossil Brachiopoda:</i> CHARLES SCHUCHERT..... | | 722 |
| <i>Astro-photographic Work to be carried out at Columbia College Observatory:</i> HAROLD JACOBY..... | | 724 |
| <i>Current Notes on Anthropology (XIII.):—</i> <i>Ancient Metal Industry in the Caucasus; Alleged Western Origin of Chinese Culture; A New Theory about the Mediterranean Race; Prehistoric Trephining in Russia:</i> D. G. BRINTON..... | | 726 |
| <i>Current Notes on Physiography (XIX.):—</i> <i>A Limestone Desert in the Alps; Morainic Amphitheater of Iroea; The Deforesting of Mountains:</i> W. M. DAVIS..... | | 727 |
| <i>Scientific Notes and News:—</i> <i>Winter Meetings of the Scientific Societies; Field Work in Geology in the University of Kansas; The Biological Experiment Station of the University of Illinois; Snakes in Oregon; General</i> | | 728 |
| <i>University and Educational News</i> | | 732 |
| <i>Discussion and Correspondence:—</i> <i>Experimental Psychology in America:</i> G. STANLEY HALL. <i>The Brehm Cuts Again:</i> ELLIOTT GOUES. <i>Quaternions:</i> VICTOR C. ALDERSON..... | | 734 |
| <i>Scientific Literature:—</i> <i>Harrop and Wallis' The Forces of Nature; Houston and A. S. Kennelly's Alternating Electric Currents. The Magnetic Resurvey of Austria and Hungary:</i> L. A. BAUER. <i>Crosby's Tables for the Determination of Common Minerals:</i> LEA MCL. LUQUER. <i>Castillo's Fauna fossil de la Sierra de Catorce, en San Luis Potosi:</i> J. B. WOODWORTH. <i>An Introduction to General Biology:</i> T. H. MORGAN..... | | 736 |
| <i>Scientific Journals:—</i> <i>American Chemical Journal:</i> J. ELLIOTT GILPIN | | 741 |
| <i>Societies and Academies:—</i> <i>New York Academy of Sciences, Biological Section:</i> BASHFORD DEAN. <i>The Torrey Botanical Club:</i> H. H. RUSBY. <i>National Geographic So-</i> | | |

ciety of Washington: W. F. M. *Geological Conference of Harvard University.* *Academy of Science, St. Louis:* A. W. DOUGLAS.....742

MSS. intended for publication and books, etc., intended for review should be sent to the responsible editor, Prof. J. McKeen Cattell, Garrison on Hudson, N. Y. Subscriptions and advertisements should be sent to SCIENCE, 41 N. Queen St., Lancaster, Pa., or 41 East 49th St., New York.

METEOROLOGY IN THE UNIVERSITY.*

THE atmosphere presents to us a purely material and mechanical aspect, and it is this which rivets the attention of the physicist properly so-called. He views the storm thundering over his head, the floods devastating the earth, the droughts destroying the crops, the hurricane lashing the ocean, and asks, is there not order and law in the midst of this confusion? It is for such a physicist, for the meteorologist proper, for him who would understand the daily weather map and would predict the weather from day to day on a rational basis, as the engineer predicts the performance of his unbuilt engine or the chemist the behavior of some novel untried combination, that I would plead. Such a student needs a collegiate course that shall fully recognize dynamic meteorology as one of the subjects in which candidates for the degree of 'Doctor of Philosophy' may prepare for examination. Thus you will solve the problem as to what

*An extract from a report presented in 1893 to President Seth Low, of Columbia College, recommending the establishment of courses in meteorology and a meteorological laboratory in connection with the University.

Columbia College can do to provide for the meteorological needs of this country. The mere statement of these subjects—the three lines of type that show the student what he may study if he will—serves as a sufficient stimulus, if his bent is in that direction.

I maintain that there is a real demand for a broad course of instruction in meteorology and that there is an abundance of work to be done, both mathematical and experimental. The courses and the laboratory work that bear on the study of the atmosphere are almost the same as those that one would naturally take up if one were preparing to be a hydraulic engineer. The fundamental question to be resolved in the study of the mechanics of the atmosphere consists in determining what the general motions of the air must be under the influence of gravitation and the rotation of the earth; of evaporation and condensation of moisture; of absorption and radiation of heat, and of the irregularities of oceans and continents, hills and valleys. If there were no solar heat the temperature would be fairly uniform at all altitudes, the earth and the sea would be frozen, there would be no clouds, and the atmosphere would be a stagnant layer revolving with the globe to which it adheres.

Professor William Ferrel, a native of Pennsylvania, was the first to solve approximately the equations of motion and deduce some of the phenomena which as observation shows actually exist. He proved that any free body in motion on a rotating surface would be deflected to the right in the northern hemisphere, and that a pressure in that direction would therefore accompany any effort to make the body move in a straight line. In consequence of this deflection a belt of low pressure must exist around the earth at the equator and areas of low pressure at the poles, with special areas of high pressure at the tropics. Among the equations of fluid motion Ferrel included the 'equation of continuity' so-

called, but found that the general solution of the problem as thus stated analytically was impracticable; he therefore took as a special solution the observed pressures and temperatures all over the globe and showed what the relative motions must be both for the lower winds and the upper atmospheric currents. He then proceeded to a discussion of the temperatures, pressures and winds that must be experienced within a region of abnormally high or low pressure, such as we now call cyclones or anti-cyclones. He derived the formula connecting the intensity of the barometric gradients with the winds that cut across them diagonally.

Ferrel's next memoir took up the thermodynamic problems, especially those that Espy had seen to be important factors in the development of our thunderstorms, showing that ascending air expands and by virtue of its expansion is cooled throughout its whole mass to an extent easily calculated by the laws of thermo-dynamics, and that when cooled below the dew point a formation of fog and cloud must result, giving rise to an evolution of heat and a delay in the cooling process, so that the moist air is warmer than the dry air would have been. Thus a cloud once formed becomes a center of aspiration, so that clouds and storms grow as long as they are supplied with uprising currents of moist air. Ferrel reduced to formulæ and figures the general doctrines of Espy and showed them to be perfectly applicable to a certain class of our storms, namely, those in which the ascent of air is sufficiently rapid to render the radiation of heat and the mixture with surrounding air matters of secondary importance.

The general treatise of Professor Ferrel entitled 'Recent Advances in Meteorology,' published by the Signal Office in 1885, gives most of his earlier results with many revisions and new ideas.

Very similar results were published by Oberbeck in 1882 and 1888, employing more elegant mathematical methods and advancing a step beyond Ferrel's first publications. It may, however, be stated that the general solution of the hydro-dynamic equations presupposes a definite knowledge of the distribution of temperature or of density in the atmosphere; and, of course, the solutions given by Oberbeck and Ferrel are intended to apply only to the atmosphere as we observe it.

The thermo-dynamic phenomena attending the ascent and descent of the air have been treated analytically by many authors, such as Sir William Thomson, Reye, Chambers, Hann, Guldberg and Mohn; within the last few years this subject has been worked out in a very elegant, graphic way by Herz and von Bezold.

The memoir of Herz considers only adiabatic changes, while the memoir of Bezold considers the changes that are not strictly adiabatic. It is evident on a slight consideration that the quantity of heat within a given mass of air is continually changing by reason of several processes: *First*, the direct absorption from the sun; *second*, radiation to colder objects; *third*, the loss by convection of heat attending the precipitation of rain or snow; *fourth*, the gain by convection attending evaporation from the earth into the air; *fifth*, the process of mixture that is constantly going on. Therefore atmospheric processes are by no means always adiabatic, and Bezold's graphic methods enable us quickly to solve any problem that may be presented. Bezold and Helmholtz have agreed in adopting and recommending the term 'potential temperature' as defining the temperature that a mass of gas would have if brought to a normal pressure, without loss or gain of heat.

Helmholtz added to our knowledge of atmospheric movements by his studies on the

conditions of stability among masses of air that have a discontinuous motion, such as two vortex rings encircling the earth in different latitudes and having different temperatures. In general, stable equilibrium is possible only when the warm ring is on the polar side of the cold ring.

A pupil of Helmholtz, Professor Diro Kitao, of the Imperial Academy of Agriculture of the University of Tokio, has made an elaborate study of the forms of motion that attend the meeting of two horizontal currents, which then pile up and roll back on themselves.

Finally, Helmholtz has given us very remarkable memoirs on waves in the atmosphere and the distribution of energy in the winds and the ocean waves. Moeller, Sprung, Hann, Wien and others have elaborated the ideas thus contributed.

The so-called 'convection theory of storms' that we call Espy's assumes that the latent heat of vapor is the maintaining power and that the original ascent of the moist, warm air is due to its buoyancy. Therefore we could have no continued cyclonic motion without ascending moisture and clouds and rain. But the other studies have, I think, put it beyond doubt that there is another equally important cause at work, which undoubtedly is the fact that the upper air flowing northward from the equator as a return trade is slowly cooling by radiation and descending. It eventually reaches the earth here and there in spots which are small areas of clear sky in the tropical regions, but are large areas of cold dry air and high pressure in northern latitudes. If the air is cooled by radiation faster than it is warmed up by the compression attending its slow descent, then it descends as clear, cold and dry air, and only after reaching the earth's surface does it begin to warm up again in the daytime faster than it can cool at night. As this dry cold air under-runs the moist, warm air at the

earth's surface, or as two areas of high pressure flowing toward each other must lift up the lighter air between them and set it into cyclonic rotation, we must, therefore, recognize the general conclusion that Espy's aspiration cyclone as developed by Ferrel is not the only form of cyclone, but that those due to descending cold air and, therefore, having the general circulation of the atmosphere as their fundamental cause are equally entitled to consideration.

To this last and latest development from the theoretical side I need only add that the study of the motions of the clouds has enabled me to assert confidently that there is no form of motion known to the student of the mechanics of fluids but what is to be found beautifully illustrated in some important phenomenon of the atmosphere. I may give one illustration of this statement.

All have seen the beautiful standing waves on the surface of a little stream of water flowing over a rocky bed. The theoretical study of these waves began with Bidone early in this century and has been especially prosecuted by Bazin and Boussinesq in France and Sir William Thomson in Scotland. Precisely similar waves must occur in the atmosphere, but can only become visible to us by the formation of clouds at the summit of each wave if the air rises high enough. Invisible standing waves exist over our heads all the time. It was my good fortune to make an extensive series of observations on a remarkably well developed system of standing waves capped by clouds, which perpetually extend from the summit of Green Mountain, on the Island of Ascension, to the leeward for a hundred miles under the influence of the steady southeast trade wind. These become invisible when the air becomes a little cooler or dryer, and consequently they actually disappear every night only to reappear as regularly every day.

But I need not dwell any longer on the

relations of the theoretical and the actually observed motions of the atmosphere. Our interest in the meteorological or dynamical theories and their application to the atmosphere is not inferior to our interest in any other physical science.

The possibility of making accurate long-range predictions of the weather and the seasons is recognized as an ultimatum that should fire the zeal of every young physicist.

Meteorology has advanced far beyond the stages of observation and generalization. It has had its Newton, Laplace, Dove, Espy, Ferrel, Oberbeck, and Helmholtz and Thomson. As an application of mathematical physics it outranks all other branches of science in its universal importance and its difficulty. Why should it not be recognized as worthy of study in our universities?

COURSE OF INSTRUCTION IN METEOROLOGY.

The following courses in the Department of Meteorology are designed to give a complete review of the present condition of that science, and are therefore necessarily extended through four years; but the series of lectures is so arranged that each of the four divisions is complete within itself; each course presents a view of a branch of the subject such as may be desired by a large number of students who need this information in connection with other branches of knowledge to which they are specially devoting themselves.

Students who intend to take the degree of Ph. D. in meteorology, and who therefore make this the major subject in connection with several other minor courses, must pursue the whole four years' course. Those who merely desire to understand observational meteorology will probably find the first year's course sufficient. Those who desire to do original work in climatological study should also take the second year.

The third year's course is designed for those who wish to perfect themselves in methods of making local weather forecasts. Finally, the fourth year's course summarizes the present state of our knowledge of the mechanics and physics of the atmosphere.

FIRST YEAR.—Observational Meteorology. The methods of observation; the simpler instruments, their errors, corrections and reductions; the theory and use of self-registers; the forms of record and computation; personal diary of the weather.

Time.—About eighty lectures, or two hours a week, as also eighty other hours of personal investigation of instruments and their exposure.

Concomitant Studies.—Algebra and trigonometry are the necessary preliminaries to this course. Elementary laboratory physics, as illustrated by Hall and Berger's text-book, is desirable as a preliminary, but may be pursued as a concomitant study. The German language is earnestly recommended as a concomitant. The differential and integral calculus should be studied as preliminary to the fourth year.

SECOND YEAR.—Climatology, both local and general; statistical meteorology, generalizations, averages, periodicities, irregularities. The relations of climate to geology, to vegetation, to animal life, and to anthropology.

Time.—About forty lectures and four hours weekly given to the investigation of special problems proposed in each lecture.

Concomitant Studies.—Students should familiarize themselves with the use of logarithms; the method of least squares; the laws of chance; the details of physical geography, orography, geology and ocean currents; the physiology of plants and animals; the distribution of species; physical astronomy, especially that of the earth, sun and moon; terrestrial magnetism; the chemistry of the atmosphere; the biology of at-

mospheric dust. Physical laboratory work on radiation, conduction and absorption of heat, on the condensation and evaporation of vapor, and on elementary electricity, is recommended. The study of German, the calculus and analytic mechanics should be continued as preliminary to the remainder of the Course.

THIRD YEAR.—Practical Meteorology; the daily weather chart; the empiric laws of weather changes as dependent on meteorological data and on the arrangement of continents, plateaus, mountains, oceans, etc.; weather types and typical weather charts; predictions of daily weather storms and general predictions of seasonal climates; verification of predictions.

Time.—About forty lectures and about five hours a week additional in verifying predictions.

Concomitant Studies.—Methods of chart projection; experimental laboratory work in both steady and discontinuous motions of fluids and gases; mathematical and experimental electricity; the laws of refraction and interference of light; elementary hydrodynamics and thermo-dynamics; differential equations and definite integrals; the German language.

FOURTH YEAR.—Theoretical Meteorology. Insolation. The absorption, conduction and radiation of heat by the air and by the earth. The thermo-dynamics and physics of the atmosphere; the graphic methods of Herz and Bezold. Convective equilibrium, as applied to the atmosphere of the sun by Lane, and to that of the earth by Sir William Thomson (Lord Kelvin), and their successors. Motion on a rotating globe; Ferrel's and other simple approximate relations between baric gradients and the wind and temperature; Ferrel's general circulation of the atmosphere and his cyclones and pericyclones and tornadoes. Galton's cyclone and anti-cyclone. Fourier's most general equations of gaseous motions.

Oberbeck's general circulation. Helmholtz' horizontal rolls. The investigations of Diro Kitao, Guldberg and Mohn, Marchi, Bousinesq, A. Poincaré, Sprung, Siemens, Moeller, Ekholm, Ritter, Lindeloff, Margules and Hermann into the motions of the atmosphere. Viscosity and discontinuity. The possible special solutions of the general equations of fluid motions that apply to the true atmospheric circulation, both on the earth and on the other planets. Atmospheric tides; theories of Laplace, Ferrel, Rayleigh, Margules, A. Poincaré. Theories of atmospheric electricity.

Time.—Eighty lectures and an additional four hours a week given to special reading and investigation and to the preparation of the final thesis, as closing the four years' course.

Concomitant Studies.—Riemann's *Differential Gleichungen*; Auerbach's *Hydrodynamics*; Lamb's *Hydrodynamics* (new edition); physical laboratory work in gaseous motions, optical and electrical phenomena.

THE METEOROLOGICAL LABORATORY.

In order to carry out an ideal course in meteorology it is necessary to not merely study lectures and text-books but the current daily weather maps; to practice the use of instruments and to keep weather records; to investigate special questions in local climatology, and to personally explore the atmosphere.

In the meteorological laboratory the student should investigate experimentally questions that arise in relation to the motions of the atmosphere, which includes almost every pertinent form of experiment in the motions of fluids and gases. Provision should also be made for the study of such optical phenomena of the atmosphere as refraction, absorption, interference, scintillation, mirage, and sunset colors.

This laboratory should also provide for study and practice with self-registers, the

study of the thermo-dynamics of the air and aqueous vapor; the determination of the amount of heat received from the sun; the continuous records of atmospheric electricity, terrestrial magnetism, earth currents, the tides and earthquakes.

The laboratory should also provide mathematical apparatus or mechanical devices by which complex questions in the motion of the atmosphere may be solved.

Facilities should be given for the study of atmospheric dust, especially in its relation to the temperature of the air and to the formation of clouds and rain.

The laboratory should contain a working library and bibliography.

CLEVELAND ABBE.

WASHINGTON, D. C.

GEOLOGIC ATLAS OF THE UNITED STATES.

FOLIO 1, LIVINGSTON, MONTANA, 1894.

THIS folio consists of $3\frac{1}{2}$ pages of text, a topographic sheet (scale 1:250,000), a sheet of areal geology, one of economic geology, one of structure sections, and one of giving a columnar section. The text is signed by Joseph P. Iddings and Walter H. Weed, geologists, and Arnold Hague, geologist in charge.

The area of country covered by the folio lies between the parallels of latitude 45 and 46 and the meridians 110 and 111, and embraces 3,340 square miles. It is within the State of Montana, including portions of Gallatin and Park counties, and the town of Livingston is within its limits. The region is elevated, the lowest point being over 4,000 feet, the major portion over 6,000 feet, and the highest peaks over 11,000 feet above sea level.

The principal topographic features are the Snowy Mountains, Gallatin Range, Bridger Range, Crazy Mountains and Yellowstone Valley. The Yellowstone River is the main drainage channel for the area. It enters the district from the Yellowstone

Park about the middle of the southern border, flows northwest and north through a closed valley 30 miles long and three miles wide, and at Livingston turns northeast and enters the broad open valley beyond the frontal ranges of the Rocky Mountains.

The rocks forming the surface of the country are partly crystalline schists, including gneiss, schists, with granite and other granular rocks; partly sedimentary formations, including limestone, sandstone and shales; and partly lavas and other igneous rocks. The crystalline schists are mainly Archean and constitute a large part of the southern half of the region. They form the higher mountains and plateau drained by Boulder River and those from Emigrant Peak south. A small area of sandstones, conglomerates, slates and arenaceous limestones occurring in the Bridger Range have been referred to the Algonkian. They lie unconformably upon the crystalline schists, and are overlain unconformably by the Paleozoic series.

The sedimentary formations cover one-half the area, and present a total thickness of 20,000 feet, embracing all the grand divisions of geologic time since the Archean. The chief feature is the great development of the latest Cretaceous strata, which are 12,000 feet thick above the Laramie, the total thickness of the Paleozoic being only 3,500 feet. The series from the basal (Flathead) quartzite to and including the Laramie coal beds is conformable throughout. The Paleozoic strata occur upturned at steep angles against the crystalline schists or in steep anticlines. The lowest bed is the Flathead quartzite. Above it are shales and limestones of Cambrian age. The Silurian is represented by only a few feet of formation, whose precise age is doubtful. Four hundred and fifty feet of shales and limestones represent the Devonian. The Carboniferous strata are 2,000

feet thick. They are here, as elsewhere, the mountain limestones and form the crest of the Bridger Range and the summits of some peaks of the Snowy Range. The Trias is recognized only in the southern part of the region, as thin belts of red sandstone. The Jura varies considerably in character, being mostly shales and fissile limestones. These two formations are 500 feet thick.

The Cretaceous constitutes more than one-half of the total thickness of strata. Its lowest member is the Dakota conglomerate with sandstone and some shale. Over this is the Colorado group, including Benton shales and Niobrara limestone, aggregating 1,800 feet in thickness. Over this is the Montana group, 1,800 feet thick, consisting of Pierre shales and Fox Hills limestones. The Laramie sandstone, with some intercalated clays and beds of coal, is 1,000 feet thick. Above this is a slight unconformity, followed by conglomerates, sandstones and clays of the Livingston formation 12,000 feet thick. Near the base the conglomerate consists largely of volcanic material. True tuff-breccia of volcanic rocks occurs intercalated near the base of the series on Boulder River.

Neocene lake beds occur in Gallatin Valley, and on Yellowstone River opposite Fridley.

Surficial deposits of the Pleistocene period occur as alluvium over all the broader river valleys. Glacial drift, consisting of gravel, sand and boulders, is scattered over the higher parts of the country and covers the Yellowstone Valley south of Chicory.

Igneous rocks occupy a large part of the area of this sheet. They consist of subaerial breccias or agglomerates with tuffs and lava flows and of intrusive bodies, such as dikes, sheets, laccolites and stocks or necks. They occur extensively in the southeastern corner of the district and form the Gallatin Range along the south-

western border and another area east of Boulder River.

In the Crazy Mountains the igneous rocks are wholly intrusive. The extrusive rocks are andesitic breccia, acid and basic; trachytic rhyolite and basalt. The intrusive rocks are gabbro, diorite, theralite, basic and acid porphyries, basic and acid andesites, and dacites. Several centers of volcanic eruptions, active in early Tertiary time, occur in the region. They are at Emigrant Gulch, Haystack Mountain and Crazy Mountains. Other centers are just outside of the limits of the atlas sheet.

The chief economic deposits of the district are the gold-bearing gravels of Emigrant, Bear and Crevice Gulches. They have been worked on a small scale. Gold veins occur in Emigrant Gulch, Crevice Gulch and Haystack Mountain. Copper ores in small quantities have been found at the head of Boulder River and of Slough Creek. Clays serviceable for brick-building occur in the alluvium near Livingston and in the lake beds near Bozeman, also in the Cretaceous strata. Two coal fields exist within the district, the Cinnabar field and the Bozeman field. The aggregate thickness of the seams is from 12 to 18 feet, made up of a number of seams, only three of which are workable. The coal is bituminous, of variable character, and in places is a fair coking coal. The output in 1889 was 49,400 tons.

FOLIO 3, PLACERVILLE, CALIFORNIA, 1894.

This folio consists of $1\frac{1}{2}$ pages of text descriptive of the Gold Belt and $1\frac{1}{2}$ pages descriptive of the Placerville district, signed by Waldemar Lindgren and H. W. Turner, geologists, and G. F. Becker, geologist in charge; a topographic map (scale 1:125,000) of the district, a sheet showing the areal geology, another showing the economic geology, and a third exhibiting structure sections.

Geography.—The territory represented lies between the meridians 120° 30' and 121° and the parallels 38° 30' and 39°, and contains 925 square miles. It is located in the upper foothill region of the Sierra Nevada, the elevation ranging from 300 feet to 5,400. The prevailing character of the topography is that of irregular and undulating plateaus, cut by deep canyons and steep ravines. The district is drained by the three forks of the American River in the northern part and by the three forks of the Cosumnes River in the southern part.

Geology.—The eastern half of the tract is principally composed of a somewhat metamorphosed sedimentary series, the Calaveras formation, of presumable Carboniferous age. The rocks consist chiefly of clay slates and quartzitic sandstones, and have in general a northerly strike and steep easterly dip. Several irregular intrusive masses of granitic rocks are contained in the sedimentary series. The western half of the tract is much more complicated. A belt of black slates belonging to the Mariposa formation, of late Jurassic age, traverses the tract from north to south. To the west of this belt follow again sedimentary rocks of the Calaveras formation, greatly cut up by igneous rocks. The sedimentary rocks here, as well as in the western part, have a northerly strike and steep easterly dip. The western part of the area contains a great abundance of basic igneous rocks, consisting of diabase, augite, hornblende porphyrite, gabbro-diorite, pyroxenite and serpentine. Over large areas certain of these basic rocks have been converted to amphibolitic schists by dynamo-metamorphic processes. Covering the ridges and resting unconformably on the older rocks are large masses of Neocene effusive rocks, chiefly tuffs and breccias of rhyolite and andesite. These masses form gently sloping tables, underneath which the Neocene gravel channels are found.

Economic Geology.—The Neocene River channels, with very highly auriferous gravel, are exposed and mined at several places in the area, for instance, at Todd's Valley, near Georgetown, and in the vicinity of Placerville. Many and important auriferous quartz veins are found in the area. The principal ones occur along the belt of Mariposa slates previously mentioned, and form the northern end of what is usually referred to as the Mother Lode of California. Passing by Nashville and Placerville, the vein is almost continuous up to the northern part of the area, where it splits up into several branches, which die out before reaching the northern border. Important veins are, however, also found both to the east and west of this belt. Near the eastern line lies the important mining district of Grizzly Flat.

There are practically no alluvial soils in the area. The deep soil on the summit of the ridges is always a residual soil, formed by the decomposition of the rocks in place.

FOLIO 5, SACRAMENTO, CALIFORNIA, 1891.

This folio consists of $1\frac{1}{2}$ pages of text descriptive of the Gold Belt and $1\frac{1}{2}$ pages descriptive of the Sacramento tract, signed by Waldemar Lindgren, geologist, and G. F. Becker, geologist in charge; a topographic map (scale 1:125,000) of the tract, a sheet showing the areal geology, another showing the economic geology, and a third exhibiting structure sections.

Topography.—The Sacramento tract includes the territory between the meridians 121° and $121^\circ 30'$ and the parallels $38^\circ 30'$ and 39° , and contains 925 square miles. The western half of the tract embraces a part of the Sacramento Valley, while the eastern half contains the first foothills of the Sierra Nevada. The elevation ranges from 30 feet above sea level at Sacramento to 2,100 feet in the northeastern corner of the tract. The foothill region forms a slop-

ing and undulating table land, through which the American River has cut a deep and narrow canyon.

Geology.—A small area of sedimentary slates of the Calaveras formation (Carboniferous) occurs in the northeastern corner, and a belt of black clay slates belonging to the Mariposa formation (late Jurassic) is contained in the igneous rocks of the southeastern part. At Folsom the Mariposa slates are cut off and contact metamorphosed by the granitic rocks of the Rocklin massif. The larger part of the older rocks of this tract is of igneous origin. A large area of diabase and porphyrite is found along the eastern margin. Wide belts of these rocks have been rendered schistose and changed to amphibolites by dynamo-metamorphic processes. Several masses of granodiorite and gabbrodiorite have been intruded into the diabases, porphyrites and amphibolites. Small masses of serpentine are sometimes found in the amphibolite; others appear intimately connected with gabbrodiorite.

Superficial flows of andesitic tuffs and breccias cover the older rocks. The larger part of these flows has been eroded. The remaining masses form sloping tables in the lower foothill region. Auriferous gravel channels are found in places below these volcanic rocks. At an elevation of 300 feet the andesite is underlain by clays and sands of the Ione formation, deposited in the gulf which in Neocene times skirted the foothills of the Sierra Nevada. The western part of the tract is largely covered by early Pleistocene deposits of gravel, sand and hardpan.

Economic Geology.—Neocene auriferous gravels have been worked to some extent east of Rocklin and south of Auburn. The Pleistocene gravels in the foothills have been very rich in gold, but are now mostly exhausted. At Folsom large masses of Pleistocene gravels are still worked. Auriferous quartz veins have been extensively

worked between Ophir and Auburn. Small veins are occasionally worked near Clarksville and in the vicinity of Pilot Hill.

The central mass of granodiorite affords excellent building stone. Limestones occur chiefly as lenses in amphibolite at many places along the eastern border. The soils of the foothill region are residuary in character, while the western part of the tract is occupied by deep alluvial and sedimentary soils.

FOLIO 7, PIKE'S PEAK, MONTANA, 1891.

This folio consists of $4\frac{1}{2}$ pages of text, signed by Whitman Cross, geologist, a topographic sheet (scale 1:125,000), a sheet of areal geology, one of economic geology, and one of structure sections, followed by a special description of the Cripple Creek mining district, consisting of 1 page of text on the mining geology by R. A. F. Penrose, Jr., and a map (scale 1:25,000) showing the economic geology of the district.

Geography.—The district embraces an area of 931.5 square miles between the meridians 105° and $105^\circ 30'$ and parallels $38^\circ 30'$ and 39° . In the eastern half of the district lies the crest of the granitic Colorado Range, which extends from Manitou Park through Pike's Peak to the southern end of the range, where it sinks to the level of the plains. The western portion of the area is a plateau, of granite and volcanic rocks, lying between 8,000 and 10,000 feet in elevation, penetrated on the south by deep canyons of streams tributary to the Arkansas River and by the recess or bay of Garden Park, nearly at the level of the plains. The principal drainage of the district is by tributaries of the Arkansas River, which flows through the Royal Gorge just beyond the southern boundary. The remaining drainage is into the Platte River, which cuts across the northwestern corner of the area in a deep canyon.

The Colorado Midland Railroad traverses

the district from east to west near its northern boundary. East of the center of the area is the mining district of Cripple Creek, reached by branch railroads from the north and south.

General Geology.—The granites of the mountain and plateau regions are reddish in color, coarse or fine grained, and similar to those of many other regions in Colorado. Of special interest is the observation, first made by the survey corps, that these granites contain many large and small fragments of metamorphosed stratified rocks, quartzites and schists belonging to the oldest series of sedimentary beds, the Algonkian, and hence the granites are not of Archean age, as has previously been assumed. Most, if not all, of the gneisses in this district have been formed from the granites by a shearing strain, as is very clearly demonstrated in many places.

The sedimentary formations of the area and their characteristics of special interest may be concisely referred to as follows:

Algonkian. Nearly 4,000 feet of white quartzite, in small part conglomeritic, is shown in the huge inclusion in granite in Wilson Park. These ancient strata are not known in this region except as inclusions.

Silurian. Three divisions of the Silurian strata, each about 100 feet thick, have been recognized in Garden Park, and named respectively the Manitou limestone, Harding sandstone and Fremont limestone. The Harding sandstone contains the oldest fossil fishes as yet known. Minor unconformities separate these formations, and they are not known in so good development elsewhere.

Carboniferous. Resting on the Silurian is a thin limestone, called the Millsap, carrying a few Carboniferous shells, and known only in small remnants. The red sandstones and grits of Manitou and Garden Parks, 1,000 feet in thickness, are considered as of Carboniferous age and named

the Fountain formation. No fossils are known in them.

The strata of the Juratrias and Cretaceous have been found in remnants upon the granite plateau, indicating a former extension of these beds connecting with South Park.

Eocene. The small lake deposit about Florissant is noted the world over for its fossil insects, while fishes, birds and many plants are also found in these thin beds, which are chiefly made up of volcanic ashes.

The volcanic rocks of the district are numerous and interesting. Those of the western portion belong to a great volcanic center south of South Park. At Cripple Creek is a local volcanic vent, the peculiar product of which is the rare rock phonolite.

Many points in the geological history of the Colorado Range have been brought out by the recent survey, such as the evidence of varying relations between land and sea at different periods, shown by unconformities and by remnants of strata on the granite plateau. The shear zones shown by the gneisses, and the observed folds and faults of the foothills, bear directly upon the structural history of this portion of the Rocky Mountains.

Economic Geology.—The gold-bearing district of Cripple Creek is directly connected with the volcanic center. The gold ores are free milling near the surface, but pass into telluride smelting ores in depth. They occur in veins, chiefly in the volcanic rocks, but occasionally in the granite near them. The extreme alteration of the rocks of the eruptive center, and the unusual character of the gold veins, have made a detailed study of the mining district necessary. A special topographic and geologic map on the scale $\frac{1}{250,000}$, or nearly $2\frac{1}{2}$ inches to the mile, has been made, and the ore deposits have been thoroughly examined by Prof. R. A. F. Penrose, Jr.

FOLIO 9, ANTHRACITE-CRESTED BUTTE, COLORADO, 1894.

This double folio consists of 3 pages of text descriptive of the Elk Mountains, by S. F. Emmons; 2 pages descriptive of the igneous formations of the two districts, by Whitman Cross; 4 pages descriptive of the sedimentary formations, by G. H. Eldridge; of each of the two districts a topographic map (scale 1:62,500), a map of areal geology, another of economic geology, and a third of structure sections; and finally, a sheet showing a generalized columnar section for the two districts.

Geography.—The combined area represented on the two sheets covers one-eighth of a degree, lying between the parallels $38^{\circ} 45'$ and 39° and the meridians $106^{\circ} 45'$ and $107^{\circ} 15'$, and is about $27\frac{1}{2}$ miles long from east to west and $17\frac{1}{2}$ from north to south. It includes the southern third of the Elk Mountain group, which lies between the Sawatch Range on the east and the plateau of the Colorado basin on the west. It is a highly picturesque and mountainous region, and, like the San Juan Mountains to the south, has a more abundant precipitation and is more alpine in its character than other parts of the Rocky Mountains.

The northern half of the eastern or Crested Butte tract is occupied by the southern portion of the Elk Mountains proper, whose culminating points have an elevation of over 13,000 feet; the southeastern portion of that tract includes the distinct and less elevated Cement Mountain uplift. The rest of this area and the whole of the Anthracite tract is occupied by more or less isolated mountain peaks—Crested Butte, Gothic Mountain, Mount Wheatstone, etc., and by one prominent north-and-south ridge, the Ruby Range, whose higher summits rise between 12,000 and 13,000 feet above sea level.

The drainage of all this area finds its

way through the Gunnison River into the Colorado, and the greater part is carried to the latter stream through the southward-flowing Slate River and its tributaries.

The towns of Crested Butte (9,000 feet) and Baldwin (8,750 feet), which are near active coal mines, are reached by branches of the Denver and Rio Grande and the Denver and South Park railroads respectively. Other towns higher in the mountains, which were founded by silver miners, are Gothic, Pittsburg and Irwin. Owing to its great altitude and abundant precipitation, this region is more or less snow-bound during eight months of the year, and mining is thereby rendered difficult and costly.

Geologic Structure.—The most striking feature in the geology of the region is the great development of eruptive rocks which occur: as irregular bodies cutting across disturbed and upturned strata; as laccolitic bodies doming up the nearly horizontal strata above a given horizon; as vertical and comparatively narrow dikes; to a limited extent as surface flows; and as a bedded series of breccias, tuffs and conglomerates.

Eruptive activity was most energetic and widespread during the Eocene Tertiary; it continued, however, sporadically, during later periods, the most recent outpourings of lava being probably of Pleistocene age. The principal rock types represented are: in the irregular cross-cutting masses, granite and diorite, and at a later period and in limited areas, rhyolite; the laccolites are mostly of porphyrite; among dike rocks are found diorite, porphyritic diorite, porphyrite and quartz porphyry; basalt occurs as a surface flow, and andesitic debris in the tuffs and conglomerates of the bedded series.

Among sedimentary rocks in this region are found representatives of the principal formations from the Archean up to the close

of the Mesozoic, with some later formations whose exact age is still somewhat doubtful. The Cambrian is represented by the Sawatch quartzite, which consists of 50 to 200 feet of white quartzite, conglomeritic at the base, and at certain horizons persistently glauconitic; its fossils are of the Potsdam type.

The Silurian beds, which are locally called the Yule limestone, in an aggregate thickness of 350 to 450 feet, consist mainly of limestones, with quartzite at the base and more shaly beds at the top. They contain the same fish remains that characterize the Harding sandstone of the Canyon City section, but organic remains have not been discovered in sufficient abundance to admit of the subdivision of the series on a paleontologic basis.

The Carboniferous is represented by three subdivisions. (1) The Leadville limestone, or Lower Carboniferous, has a thickness of 400–525 feet of dark gray or blue limestones, with some intercalated quartzites and shales. Above this is (2) the Weber formation, which consists of 100–500 feet of shales and limestones, carrying fossils of Coal Measure type. The upper member, known as (3) the Maroon conglomerate, consists mainly, as its name indicates, of conglomerates, which are characterized by the local abundance of pebbles of limestone. It has an observed maximum thickness of 4,500 feet, and in its upper portion resembles lithologically the Red Beds, generally assigned to the Trias.

The Juratrias, whose beds are separated from the last mentioned by a great unconformity, is represented by the Gunnison formation, which consists of a heavy white sandstone, about 100 feet in thickness, overlain by shales and a little limestone, and carries a fresh water-fauna of supposed Jurassic age.

The Cretaceous is represented by five recognized subdivisions: The Dakota

quartzite, 50-300 feet thick; the Benton shale, 150-300 feet thick; the Niobrara limestone, 100-200 feet thick; the Montana formation, comprising the Pierre shales and Fox Hills sandstones, 600-2,000 feet thick; the prevailing lithologic characteristics of each of which are indicated by its name. Among later beds are the Ohio formation, about 200 feet of sandstones and conglomerates, and the Ruby formation, with a maximum thickness of 2,500 feet of sandstones, shales and conglomerates made up to a large extent of eruptive debris. These formations are separated by an unconformity from the underlying Laramie, and to the west of this area pass beneath the beds of the Wasatch Eocene; in the absence of fossil evidence they have been classed as Cretaceous.

The geologic structure of this region affords evidence of no less than four important orographic movements, involving the making of new land, the erosion and planing down of the same and the inauguration of a new cycle of sedimentation, which account for the great variation in thickness of certain formations. First, during Post-Archean time, the first deposits, after which were Upper Cambrian (Sawatch quartzite); second, during Carboniferous time, followed by deposition of Weber shales and Maroon conglomerates; third, during Mesozoic time, followed by deposition of the Gunnison sandstone; and fourth, after Laramie time, followed by the Ohio, Ruby and Eocene formations.

Mineral Resources.—The most important economic product of the region is its coal, which is found in the lower part of the Laramie Cretaceous formation, between beds of sandstone. The quality of the coal varies, according to local conditions more or less favorable to metamorphism, from dry bituminous, through coking coal, to semi-anthracite and anthracite. Next in importance are its silver ores, which occur for the

most part in true veins or fault fissures in all varieties of rock, but mainly in the sedimentary beds of upper horizons near eruptive rocks. The ores are generally rich, but in small bodies, and, in consequence of natural obstacles to cheap mining, have not been extensively worked. Gold has been found in paying quantities in the alluvium of a single gulch; lead and copper are accessory products in limited amounts.

FOLIO 10, HARPER'S FERRY, VIRGINIA, MARYLAND, WEST VIRGINIA, 1894.

This folio consists of 4 pages of descriptive text, signed by Arthur Keith, geologist; 1 page of columnar section, a topographic map (scale 1:125,000), a sheet showing the areal geology of the district, another showing the economic geology, and a third exhibiting structure sections.

The folio describes that portion of the Appalachian province which is situated between parallels 39° and 39° 30' and meridians 77° 30' and 78°. The tract contains about 950 square miles and falls within Washington and Frederick counties, Maryland; Loudoun and Fauquier counties, Virginia; and Jefferson county, West Virginia.

The folio begins with a general description of the province, which shows the relation of the Harper's Ferry tract to the whole. Then the local features of the drainage by the Potomac and Shenandoah rivers and their tributaries (Goose, Antietam and Catoctin creeks) are treated. The various forms of the surface are pointed out, such as Shenandoah Valley, Blue Ridge and Catoctin Mountain, and their relations to the underlying rocks are made clear.

Under the heading Stratigraphy the geologic history of the Appalachian province is presented in outline, and the local rock groups are fully described in regard to composition, thickness, location, varieties, and mode of deposition.

The formations range in age from Algonkian to Cretaceous, the greater portion being Algonkian, Cambrian and Silurian. The Silurian rocks appear in the Shenandoah Valley, the Cambrian in Catoctin Mountain and Blue Ridge, the Algonkian between these ridges, and the Juratrias east of Catoctin. The Algonkian rocks are chiefly granite and epidotic schist; the Cambrian rocks, sandstones and shales, passing up into limestones; the Silurian rocks, limestones and shales; and the Juratrias rocks, red sandstone and shale and limestone conglomerate. The details of the strata are shown in the columnar section. The manner in which each kind of rock decays is discussed, and how the residual soils and forms of surface depend on the nature of the underlying rock.

In the discussion of Structure, after a general statement of the broader structural features of the province, three methods are shown in which the rocks have been deformed. Of these the extreme Appalachian folding is the chief; next is that developed in the Juratrias rocks, and least in importance are the broad vertical uplifts. Three degrees of extreme deformation appear in the Paleozoic rocks—folding, faulting and metamorphism—each being best developed in a certain kind of strata. Between Blue Ridge and Catoctin Mountain the Algonkian or oldest rocks appear on a great anticlinal uplift, with Cambrian rocks on either side. Faults appear chiefly on the west side of this uplift, and metamorphism increases toward its east side. In the Shenandoah Valley the rocks are folded to an extreme degree, and the strata are frequently horizontal or overturned. The Juratrias rocks always dip toward the west, and are probably repeated by faults different in nature from the Appalachian faults. In the sheet of sections the details of the folds and faults appear.

Economic products of this region com-

prise copper and iron ore; ornamental stones, such as marble, limestone conglomerate and amygdaloid; building stones, such as sandstone, limestone and slate; and other materials like lime, cement, brick clay and road materials. The localities of each of these materials are noted and quarries located on the economic sheet, and the character and availability of the deposits are discussed.

AMERICAN FOSSIL BRACHIOPODA.

THE writer has had in preparation since 1886 'A Synopsis of American Fossil Brachiopoda, including Bibliography and Synonymy.' This work, now completed, will appear as one of the Bulletins of the U. S. National Museum and embraces the following chapters: I. Geological Development; II. Brachiopod Terminology; III. Biological Development; IV. Morphology of the Brachia, by Charles E. Beecher; V. Classification; and VI. Index and Bibliography. The following summary, taken from this work, gives some of the more important results obtained, all of which are discussed at length in the work above cited.

In North America there are one thousand eight hundred and forty-six Paleozoic, thirty-seven Mesozoic, and nine Cenozoic species of fossil Brachiopoda. There are one hundred and one species in the Cambrian, three hundred and eleven in the Ordovician, three hundred and twenty in the Silurian, six hundred and fifty-five in the Devonian, and four hundred and eighty-two in the Carboniferous.

This remarkable scarcity of Post-Paleozoic species in America is supposed to be due not so much to the general decline of of the class as to great orographic movements during the close of the Paleozoic, thus producing complete barriers against the introduction of species from other areas. Moreover, few marine sediments are found in them.

Specific differentiation was most rapid in the Ordovician, having exceeded the Cambrian representation more than three times.

Thirty per cent. of all American Paleozoic species had wide geographic distribution, and this is most pronounced in the Devonian and Carboniferous systems. One hundred and twenty-one American species are also found on other continents.

Widely dispersed species are least common in the most primitive order, Atremata, and greatest in the highest orders, Protremata and Telotremata. The difference, however, is but seven per cent.

The order Atremata is represented by one hundred and ninety-six species, or over ten per cent. of the American Paleozoic representation. In the Neotremata it is one hundred and fifty-three, or over eight per cent. The Protremata have seven hundred and thirty-five species, or nearly forty per cent., and the Telotremata seven hundred and sixty-two species, or about forty-one per cent.

The order Atremata is best developed in species and genera in the Cambrian and Ordovician systems; the Neotremata in the Ordovician; the Protremata in the Ordovician, Silurian and Devonian; and the Telotremata in the Devonian. The climax of differentiation is therefore chronologically related to phylogenetic or sequential origin.

Since the four orders of Brachiopoda are present in the Lower Cambrian, ordinal differentiation must have taken place in Pre-Cambrian times. The two more primitive orders, Atremata and Neotremata, have in *Lingula* and *Crania*, respectively, genera with longest life histories. This probably is due not so much to their primitive structures as to their modes of living.

The last order to originate, Telotremata, has the greatest number of generic and superfamily characters and probably also of species.

The last superfamily to appear, *Spiriferacea*, manifests most rapid evolution and is the second one to die out, being preceded by the *Pentameracea*. These two superfamilies are the most highly specialized in the orders to which they belong, and their great specialization may be the cause of their early disappearance.

The trunk families of later origin throughout the class manifest the greatest specific and generic differentiation, the widest specific dispersion, and have species of the largest size and often of longer geologic persistence.

The oldest or most primitive families nearly always have short geologic duration (except *Rhynchonellidae*), the least generic and specific differentiation, and commonly the individuals are of small size.

The largest of all brachiopods occur in the families *Pentameridae*, *Productidae*, and *Spiriferidae*, at a time when the class was at the height of differentiation.

Large specific size is probably often gradually attained in genetic lines, and is due to favorable food conditions. The gigantic brachiopods always occur in the later developed trunk families, and just before their decline in differentiation.

But eight genera are known to pass from the Paleozoic to the Mesozoic. There are in all three hundred and twenty-one brachiopod genera, two hundred and twenty-three of which are Paleozoic. The Atremata have twenty-six genera; the Neotremata, thirty-one; the Protremata, eighty-seven; and the Telotremata, one hundred and seventy-five.

All brachiopods begin with smooth shells and protogula.

The prodeltidium, or third embryonic shell plate, is known in the Atremata, Neotremata and Protremata. In the Atremata this becomes attached to the dorsal valve, while in the Telotremata it is not apparently developed at all. In the Pro-

tremata it becomes attached to the ventral valve, as in Neotremata. In the two last named orders it modifies the pedicle opening. For this and other ontogenetic and morphologic characters Owen's terms *Lyopomata* and *Arthropomata* are abandoned. The *Atremata* and *Telotremata* are provisionally arranged under the superordinal term *Homocaulia*, and *Neotremata* and *Protremata* under *Idiocaulia*.

A true deltidium is present in the *Acrotretacea* of the *Neotremata* and in the *Protremata*.

"The cirrated lophophore, or brachia, is alike in the larval stages of all brachiopods. They first develop tentacles in pairs on each side of the median line in front of the mouth (taxolophus stage). New tentacles are continually added at the same points, until by pushing back the older ones there is a complete circle about the mouth (trocholophus stage), later becoming inverted in front (schizolophus stage). From this common and simple structure all the higher types of brachial complication are developed through one of two methods: (1) the growing points of the lophophore, or points at which new tentacles are formed, remain in juxtaposition; or (2) they separate. Complexity in the first is produced (a) by lobation, as in *Magathyris*, *Eudesella*, *Bactrymium*, *Thecidea*, etc. (ptycholophus type), and (b) by looping (zugllophus) and the growth of a median, unpaired coiled arm (plectolophus), as in *Magellania*, *Terebratulina*, etc.; in the second (c) by the growth of two, separate, coiled extensions or arms, one on each side of the median line (spirolophus), as in *Lingula*, *Crania*, *Disciniscia*, *Rynchonella*, *Lepetana*, *Davidsonia*, *Spirifer*, *Athyris*, *Atrypa*, etc." [Charles E. Beecher.]

Morphological equivalents, or similar structural features, are developed independently, as follows: A spondylium in *Obolacea*, *Lingulacea*, *Pentameracea*, and rarely in *Spirif-*

eracea; crural processes in *Pentameracea* and *Rynchonellacea*; functional articulation in *Protremata* and *Telotremata*; straight, more or less long, cardinal areas from rostrate forms in *Rynchonellacea*, *Spiriferacea* and *Terebratulacea*; rostrate shells from long cardinal areas in *Pentameracea*; and loss of pedicle and ventral shell cementation in *Crania*, *Strophomenacea* and *Spiriferacea*.

CHARLES SCHUCHERT.

U. S. NATIONAL MUSEUM.

ASTRO-PHOTOGRAPHIC WORK TO BE CARRIED OUT AT COLUMBIA COLLEGE OBSERVATORY.

ONE of the great difficulties that has stood in the way of attaining the highest precision in photographic astrometry has been the determination of a possible distortion of the field of the photographic telescope. Some years ago Dr. Gill tried to meet this difficulty by recommending the possessors of photographic telescopes to make a series of pictures of the group of stars he had used as comparison stars for the planet Victoria in his Solar Parallax work. These stars had been very carefully determined, both in the meridian and with the heliometer, so that a mere comparison of the photographic coördinates with the others ought to throw considerable light on the question of the optical distortion of the photographic telescope. This process has been very carefully carried out by Donner, at the Helsingfors observatory. But the result he has secured leaves the matter still in doubt. His determination of the optical distortion of the Helsingfors telescope by Gill's method does not possess sufficient weight. The cause of this partial failure of Gill's method must be sought in the unfavorable distribution of the Victoria stars for the purpose of question, in the small remaining errors of Gill's star positions, the uncertainty of the proper motions, and perhaps also in the low alti-

tude of these stars in the latitude of Helsingfors.

Some time ago I pointed out in the *Astronomical Journal* that the best method of investigating that portion of the optical distortion which depends on position angle would be to photograph the stars surrounding the pole several times, with widely different readings of the hour circle. In this way the quantity sought will not be dependent on star places or proper motions, and a very favorable distribution of the stars can easily be secured. Such a research can be made to furnish incidentally a very accurate catalogue of the stars surrounding the pole.

Through the courtesy of Dr. Gill and Professor Donner I have secured a collection of polar plates of the two poles specially made for the present purpose, and I propose to effect the measurement and reduction of these plates at Columbia College, using the Repsold photographic measuring machine recently presented to the College by Mr. Rutherford Stuyvesant. The plates are twelve in number for each pole, and are symmetrically distributed about the pole in the manner most favorable for the purpose in hand. It is to be noted also that the observatories of the Cape and Helsingfors are the most favorably situated respectively for the North and South Poles. We may therefore confidently expect considerable information on this difficult point, if the present research can be carried to a successful conclusion.

Other astro-photographic work going on under my immediate supervision includes the re-measurement of the old Rutherford plates of the Pleiades which were discussed in my paper on that group of stars. It is hoped that this re-measurement will show that the old plates have not deteriorated. If this be the case we can proceed at once to the measurement of a great number of Rutherford plates that have never been

measured at all. The great importance of these plates arises from the fact that they have a thirty-year precedence of all other plates for the purpose of making a study of proper motions.

Dr. Davis has been working on the reduction of the plates measured by Rutherford and has carried several clusters almost to completion. These include the stars surrounding *Mu Cassiopeiæ*, 1830 Groombridge, 61 Cygni, and one or two others. All these are being computed in a manner similar to the process used in the case of the Pleiades. Dr. Davis also has in hand a study of the relative masses of the two components of the double star *Eta Cassiopeiæ*, from the Rutherford measures recently published by him. This work is being done according to formulæ which I presented at a recent meeting of the New York Academy of Sciences. Especial thanks are due to Prof. J. K. Rees, director of the observatory, who has done everything in his power to further the prosecution of the above researches.

Among other researches of importance which cannot be actively pushed at present, on account of insufficient assistance, I may mention the measurement and reduction of a series of plates of the stars used by Gill for comparison with the planet *Victoria* in his Solar Parallax work. These plates were made at the Cape Observatory about the time of the *Victoria* observations, and they have been placed in my hands by Dr. Gill for discussion. The plates are now at Columbia College. All the plates to which reference has been made in this notice, except Rutherford's, are provided with a 'Réseau,' or network of straight lines photographed on the plate. By the aid of this réseau it is certain that we can eliminate the effects of any distortion of the film during development. The measurement is also greatly facilitated by it. It is to be hoped that Columbia College will in time possess

an organized Bureau of Measures, where astro-photographic researches can be carried out for other astronomers who have not the facilities or the means of doing the work themselves.

HAROLD JACOBY.

CURRENT NOTES ON ANTHROPOLOGY (XIII.)
ANCIENT METAL INDUSTRY IN THE CAUCASUS.

A VALUABLE monograph has lately appeared, by Professor Rudolph Virchow, in the Proceedings of the Prussian Academy of Sciences under the title, 'The Culture-Historical Position of the Caucasus, with special reference to the ornamented bronze girdles obtained from Trans-Caucasian graves.'

It appears that from the oldest burial sites in Trans-Caucasia specimens of metal-work are exhumed, remarkably beautiful in design and proving a highly developed technique. Careful studies have shown that this was not an indigenous industry. The artists had learned their trade elsewhere, or had immigrated from other lands. They were not in close relation with the contemporary art of Armenia; nor is the Assyrian or Babylonian influence especially pronounced, though at times visible. The art motives are unlike those which prevailed in Europe. Perhaps the connection should be sought with the prehistoric culture of Persia; but of this we have at present too few examples to speak of it positively. This much Dr. Virchow makes clear: That the Caucasian art was not developed *in situ*; that it was unexpectedly rich; that it is Oriental in inspiration; and that it points to some older center of culture not yet located.

ALLEGED WESTERN ORIGIN OF CHINESE CULTURE.

READERS acquainted with the voluminous writings of the late Terrien de La Couperie will recall the zeal with which he expounded and defended the theory that the origin of Chinese culture should be sought in Meso-

potamia, among the Elamites of Susa. A number of them, he claimed, migrated eastward, carrying with them an advanced civilization, and appear in Chinese history as the 'Bak' tribes, those now referred to as the *Pe Sing*, 'the hundred-named.' He further explained that *Pe*, *Pek*, or *Bak*, was in origin a *nomen gentile*, non-Chinese in derivation, but assigned a meaning later in that language. These opinions he defended with much vigor.

They have, however, been completely demolished by M. de Harlez, in the October number of Schlegel's *Archives de L'Orient*. His exhaustive discussion of the etymology of *Pe Sing* leaves no doubt of the incorrectness of de La Couperie's assumption; and the theory of the extension of the Mesopotamian culture into China, as well as that of the imagined presence of the true Mongolian race in the Euphrates Valley in prehistoric times, are both rudely shaken. In a paper on 'The Proto-historic Ethnography of Western Asia,' which I published last spring in the Proceedings of the American Philosophical Society, I pointed out how frail was the foundation of both assumptions.

A NEW THEORY ABOUT THE MEDITERRANEAN RACE.

PROF. GIUSEPPE SERGI is well known for his extended anthropological studies, and especially for his novel craniological methods. Quite recently he has published a volume of 144 pages with a map and outlines of skull forms, to make known his conclusions on the origin of the Mediterranean race (*Origine e Diffusione della Stirpe Mediterranea*, Roma, 1895).

After clearing the ground of a number of opinions contrary to his own, he proceeds to demonstrate that the ancestors of the Egyptians, Aryans, Libyans, Pelasgians and Etruscans migrated from a 'center of diffusion' in Africa, near the headwaters

of the river Nile. He believes that he is able approximately to trace their early wanderings and to some extent their admixtures, by a comparison of skull forms. At this time, when there is so little unanimity among craniologists as to the value of their science in ethnography, it seems rather daring to select it as the corner stone of any hypothesis of ancient relationship; and it may be regarded as very doubtful whether Prof. Sergi will find many to accept his conclusions.

PREHISTORIC TREPANING IN RUSSIA.

AN article by General von Krahmer in the *Globus*, Bd. LXVII., No. 11, describes an amulet obtained in 1883 from a neolithic burial in Russia. It was of bone, and on examination proved to have been taken from a human skull. Ten years later the archæologist Bieljachewski, in exploring a deposit on the banks of the Dnieper, exhumed a human skull from which just such a fragment must have been removed. Careful inspection showed that the trepanation had been performed after death, the spot selected being the right frontal bone. The instrument must have had a sharp cutting edge, but a lack of skill is manifested in the use of it. The skull belonged to a comparatively young person, probably a woman. From objects collected in its immediate vicinity, it may be assigned to the twelfth century.

Such examples are extremely rare in Russia. Among the crania at the anthropological museum in Moscow there is but one which shows ancient trepanation; but it is catalogued as from the Caucasus. However, the evidence brought forward by General von Krahmer, showing that this operation was occasionally practiced in order to obtain amulets from the parietes of the skull, is valuable as illustrating a primitive superstition which prevailed in several widely separated tribes.

D. G. BRINTON.

UNIVERSITY OF PENNSYLVANIA.

CURRENT NOTES ON PHYSIOGRAPHY (XIX.).

A LIMESTONE DESERT IN THE ALPS.

MUCH has been written about the barren and weathered limestone areas known as Lapiés, Lapiaz, or Karrenfelder, in the Alps. An interesting and well-illustrated account of the peculiar rock forms occurring on one of these areas, the 'Desert of Platé,' in the Alps of Savoy, is lately presented by E. Chaix, of the Geneva cantonal school of horticulture (*La topographie du desert de Platé*, *Le Globe*, Genève, xxxiv, 1895, 67-108, excellent plates, map, 1:5,000). The desert occurs at an elevation of from 1,900 to 2,000 meters, an inextricable chaos of angular limestone ledges, a labyrinth of curiously sculptured rocks and deep worn crevasses. The surface chisellings are in the form of little troughs, varying in size in different strata, but always leading down the slope of the rock; these are ascribed to post-glacial wasting and washing. The crevasses, or open joints, are of older diastrophic origin but of modern weathering; they intersect successive strata, varying in width of opening as they pass from one bed to another, sometimes single and simple, sometimes very confused in their arrangement. A good review of previous writings on this subject is included in the essay.

MORAINIC AMPHITHEATER OF IVREA.

BESIDES the existing lakes enclosed by moraines at the Italian base of the Alps, there are certain extinct lakes—now alluvial plains—similarly enclosed; that of Ivrea, where the valley of the Dora Baltea opens from the mountains upon the great fluvial plain, being the most remarkable. Agostini describes this great amphitheater in connection with its peat deposits (*Le torbiere dell' Anfiteatro morenico d' Ivrea*. *Rev. geogr. ital.*, ii, 1895, 278-294, map). The best peat is found in the comparatively small basins that occur in the irregular

morainic wall; the small inwash of alluvium probably explaining the purity of these deposits. The great basin enclosed by the moraine is almost filled by the alluvium of the Dora Baltea, but at the extreme front of the amphitheater directly next to the inner slope of the moraine, and some distance on either side of the medial course of the river, two shallow lakes, Viverone and Candia, with marginal peat deposits, still remain. Other small basins, either lakes or peat bogs, occur on the alluvial plain and in shallow rock basins near the head of the amphitheater.

THE DEFORESTING OF MOUNTAINS.

A NATIONAL congress of French geographical societies was held last year at Lyons, and a report of its proceedings has been published by the geographical society of that city. To this volume Guénot, of Toulouse, contributed an essay on the effects of the deforesting of mountains, a subject to which he had previously given much attention. The Causses, plateau-like uplands in southern France, have for various reasons, historical and political, been gradually stripped of their forests, and as a result they are largely depopulated; twenty years has sufficed to transform a wooded district into a stony desert. In the Pyrenees the reports of the forestry officials show a constant relation between deforesting and various injurious effects, such as the stripping of soil from the slopes, the increased violence of floods in the mountain torrents and the decrease of population. In some valleys forest area and population have fallen to half their former numbers; in others the complete destruction of the forests has been followed by the complete abandonment of the district. Guénot urges a revision of the existing forestry laws in France, the extension of an organization known as the '*amis des arbres*,' and the introduction of tree-planting, as with us

on Arbor Day. Confidence in the author is somewhat shaken by his exaggerated ideas about American matters; deforesting in this country is held responsible for severe droughts, for extreme heat and cold, and for heavy rains and floods; while our Arbor Day is described as a popular, national and religious fête, 'celebrated with the most astonishing solemnity.' W. M. DAVIS.

HARVARD UNIVERSITY.

SCIENTIFIC NOTES AND NEWS.

WINTER MEETINGS OF THE SCIENTIFIC SOCIETIES.

The American Society of Naturalists and the affiliated and related societies will meet at the University of Pennsylvania, Philadelphia, on the days immediately following Christmas, December 26th, 27th and 28th. The Society of Naturalists will meet on the afternoon of the 26th to organize and to hear the address of the President. The meetings promise to be of unusual scientific interest, and all possible arrangements have been made to contribute to the social entertainment of the members. The officers of several societies are as follows: *The American Society of Naturalists*—President, Prof. E. D. Cope, University of Pennsylvania; Secretary, Prof. H. C. Bumpus, Brown University. *The American Morphological Society*—President, Prof. E. B. Wilson, Columbia College; Secretary, Dr. G. H. Parker, Harvard University. *The American Physiological Society*—President, Prof. H. P. Bowditch, Harvard University; Secretary, Prof. S. F. Lee, Columbia College. *The Geological Society of America*, President—Prof. N. S. Shaler, Harvard University; Secretary, Prof. H. L. Fairchild, University of Rochester. *The Association of American Anatomists*—President, Dr. Thomas Dwight, Harvard University; Secretary, Dr. D. S. Lamb, Washington. *The American Psychological Association*—President, Prof. J. McKeen Cattell, Columbia College; Secretary,

Prof. E. C. Sanford, Clark University. Programs of the meetings and other information can be obtained from the Secretaries.

FIELD WORK IN GEOLOGY AT THE UNIVERSITY OF KANSAS.

In the spring of 1895 the Board of Regents of the University of Kansas formally opened the University Geological Survey of Kansas, a bureau which they were authorized to establish at their discretion, by the law making appropriation for the University in 1889, and repeated in every appropriation bill passed by the Kansas Legislature since that time. Active field work was begun in the summer of 1893 and has been prosecuted with increasing vigor each succeeding summer. In 1893 Prof. Haworth, of the department of physical geology and mineralogy in the University, had three men in the field. They succeeded in running geologic sections in various places in the southeastern part of the State, and published a brief account of the results in the *Kansas University Quarterly*, January, 1894. During the summer of 1894 he had five men in the field who continued investigations in stratigraphy in eastern Kansas. Some of the results of this season's work were given in the *University Quarterly* of April, 1895. During the summer of 1895 the work was greatly extended. The Legislature passed a bill creating a State Board of Irrigation, of which, it is provided, 'the professor of geology in the University' should be a member. This added greatly to the opportunities of the University, as additional funds were available for expenses. A total of twelve men, besides Prof. Haworth, were engaged for longer or shorter periods during the summer, five of whom were working with special reference to the water problems in the western part of the State, two others in the Cretaceous doing stratigraphic and areal work, one devoting his time exclusively to the salt deposits of

the State, one to a detailed study of the coal mines and mining, one to a study of glacial phenomena in northeastern Kansas, and others to general stratigraphic work in the Carboniferous.

As a result of these various operations a volume on the stratigraphy of the Carboniferous is now ready for publication. A preliminary report on the water supply of the western part of the State will be completed by the last of December, and large quantities of material have been gathered for succeeding volumes on the stratigraphy of the Cretaceous and Tertiary of the State, on the economic geology of the State, etc. The question of publication is not yet definitely settled, as the Legislative enactment made no special provision for it; but it is hoped that in one way or another the work of the organized survey will not be seriously hindered by a lack of means for publication.

THE BIOLOGICAL EXPERIMENT STATION OF THE UNIVERSITY OF ILLINOIS.

THOUGH established with the primary aim of affording opportunity for research for its own staff, the Station will in future be open during the months of June, July and August to biological investigators and to students of some experience in zoölogical or botanical work.

The Station is established on the Illinois River, with principal headquarters at the county town of Havana, forty miles below Peoria and a hundred miles west of the University of Illinois. It has for its field of operations the banks and waters of the Illinois River itself and a selected series of lakes, streams and bayous of the vicinity, presenting an extraordinary variety of situations, rich beyond any ordinary experience in number and variety of plant and animal forms. The collecting stations are all within convenient access from the town, at outside distances of a mile to the south and three miles to the north.

Those whose experience has been confined to the seashore or to our inland lakes, large or small, can have but little conception of the abundance of biological material accessible, with the minimum of effort and expense, to the student at the Illinois Station.

The laboratory is fully equipped with all necessary appliances. The present accommodations are sufficient for sixteen persons.

SNAKES IN OREGON.

In the vicinity of Klamath River, Klamath county, Oregon, a certain species of *Eutania* swarms by scores, by the hundreds and by the thousands. They are found mostly along the water courses in the grass or sunning themselves on the bare rocks or driftwood in the streams or on their banks.

The accompanying illustration is from a



Applications for admission must be made in advance and at as early a day as practicable, with precise specification of the period for which the applicant wishes to occupy a table in the Station laboratory. All further particulars may be obtained from the director, Prof. S. A. Forbes, Urbana, Ill.

photograph made on a branch of the Klamath River, three miles south of Klamath Falls, Oregon. It was obtained in the latter part of July last and kindly furnished us by Mr. James A. Diggles, a student of geology at Stanford University. The negative was made about ten o'clock in the morning. Such a display is by no means

an exceptional one along this stream; indeed this photograph was made only a few paces above the public road which crosses the stream a little to the left of the view. The snakes are harmless. Mr. Diggles says that there is a species of water frog quite as abundant in that region as the snakes, and that the snakes are said to feed on the frogs.

GENERAL.

At the recent meeting of the French Association for the Advancement of Science at Bordeaux a committee composed of M. Boudouin, director of the International Institute of Scientific Bibliography; M. R. Blanchard, general secretary of the Zoölogical Society of France; M. Cartaz, assistant secretary of the Council of the French Association; M. Gabriel, secretary of the Council of the Association, and M. Ch. Richet, editor of the *Revue Scientifique* and professor of physiology in the Medical School of Paris, presented a report on the titles that should be given to scientific articles in order to make their bibliographic classification easier. The report was discussed at a special session of the Association and two recommendations were adopted: That titles should be made as brief and exact as possible and that the word characterizing the subject treated should be italicized. In case subdivisions of a subject are treated, these should be indicated by words in the title, the first half of which words should be italicized. The recent International Biographical Conference approved this plan, and it will be adopted by several journals, including the *Revue Scientifique*.

A BRIGHT comet was discovered during last week at Lick Observatory, in right ascension 13 deg. 44 min., north declination 1 deg. 40 min., in the constellation of Virgo. The comet has a short tail and a stellar nucleus of about the seventh magnitude.

DR. F. P. PORCHER, a well-known physician and botanist, died at Charleston, S. C.,

on November 19th, at the age of seventy. He was professor of materia medica and therapeutics in the Medical College of the State of South Carolina and was the author of numerous works on pharmaceutical botany.

CARL STECKELMAN, known for his explorations in South Africa, was drowned on August 28th.

DURING the summer vacation Prof. G. C. Comstock, director of the Washburn Observatory and professor of astronomy in the University of Wisconsin, coöperated with the authorities of the University of Minnesota in determining the longitude of their new observatory by an exchange of telegraphic time signals between Madison and Minneapolis. Mr. A. S. Flint, assistant astronomer in the University, recently presented to the American Association for the Advancement of Science the partial results of an extensive series of observations made at the Washburn Observatory for determining the distances of the nearer fixed stars. This work is now approaching its completion and will be the most comprehensive series of determinations of stellar distance ever made.

PROF. GEORGE M. DAWSON, director of the Geological Survey of Canada, who died recently at Halifax, Nova Scotia, was the son of Sir J. William Dawson, and was born at Pictou, Nova Scotia, on August 1, 1849. The *London Standard* states that he was appointed Geologist and Naturalist to her Majesty's North American Boundary Commission in 1873, and in 1875 he published a detailed report on the country traversed from the Lake of the Woods to the Rocky Mountains, entitled 'Geology and Resources of the 49th Parallel.' He was appointed to the Geological Survey of Canada in 1875, and had since been principally engaged in the survey and exploration of the Northwest Territory and Brit-

ish Columbia, and was placed in charge of the Yukon expedition, undertaken by the Canadian government in 1887. As one of her Majesty's Behring Sea Commissioners he spent the summer of 1891 in investigating the facts connected with the fur-seal fishery on the northern coasts of America and Asia. Two years later he was elected president of the Royal Society of Canada. In January, 1895, he was appointed director of the Geological Survey of Canada. He was the author of numerous original scientific papers, principally geological, but including geographical, ethnological and other observations made in the course of his explorations.

MR. EDWARD PHILIP LOFTUS BROCK, honorary secretary of the British Archaeological Association, died in London on November 2d.

MR. BERNARD GRENFELL, fellow of Queens College, Oxford, intends shortly to visit Egypt to continue his studies on Greek papyri.

THE *Boston Transcript* states that Prof. David P. Todd will undertake the direction of an expedition to be sent out from Amherst College for the purpose of observing the solar eclipse of 1896. The expedition will sail from San Francisco next spring, on the schooner yacht *Coronet*, which will be in command of Captain Arthur C. James, New York Yacht Club, a member of the class of '89. The island of *Yezo*, one of the largest northern islands of the Japanese Empire, has been chosen as the point of observation.

THE Pharmaceutical Society of Great Britain has presented the Hanbury Medal to Dr. August Vogl. This is the eighth award of this medal, which was presented in 1881 to Flückiger, in 1883 to John Elliot Howard, in 1885 to Dragendorff, in 1887 to Dymok, in 1889 to Plaichon, in 1891 to Hesse and in 1893 to Maish.

At a meeting of the Royal Institution on November 4th it was reported that the late Mr. John Bell Sedgwick, M.R.I., had bequeathed £300 to the Royal Institution in aid of the fund for the promotion of experimental research at low temperatures. The special thanks of the members were returned to Sir Frederick Abel for his donation of £50 to the same fund.

DR. FRASER HARRIS proposed exhibiting before the Glasgow Philosophical Society a new optical instrument known as the stereophoto-chroscope, the aim of which is to photograph an object in such a way that the 'positive' of the picture, viewed as a transparency, will present the object with its natural colors and also with stereoscopic effects.

THE *Revue Scientifique* states that M. G. Delage will issue at the beginning of next year an *Année biologique*, which will give analytical and critical reviews of publications in general biology.

A COURSE of Monday evening lectures has been instituted by the faculty of the University of the City of New York, who will lecture on their respective subjects to the people living in the vicinity of University Heights. The first lecture was delivered by Dr. J. J. Stevenson, in the lecture room of the Havemeyer Laboratory, on 'Coal.'

UNIVERSITY AND EDUCATIONAL NEWS.

PROF. WILLIAM M. THORNTON, chairman of the faculty of the University of Virginia, has published a letter stating the needs and plans of the University. Reconstruction of the Rotunda, the central building of the group recently destroyed, has already been begun. It will be restored in its original form, a reproduction on the half scale of the Roman Pantheon, but with fire-proof materials. The necessary money for this purpose, about \$80,000, has been practically subscribed.

In place of the large rectangular annex to the Rotunda, built in 1852 for the accommodation of the growing classes of the University, a number of isolated structures will be erected. They are to be a general academical building costing \$90,000, a physical laboratory costing \$30,000, a building for mechanics and engineering costing \$30,000, and a building for the law school costing \$20,000. Governor O'Ferrall has promised to recommend in his message to the State Legislature a prompt and liberal appropriation to repair the losses of the school, and it is hoped that \$200,000 will be received from this source. Friends of the University and of Education are urged to contribute liberally to the rebuilding and enlargement of the University.

DAVID J. HILL, President of the University of Rochester, has resigned. The action is said to be on account of the opposition to him manifested by conservative Baptists who have not favored his liberal views and management of the University.

At its last biennial session the Legislature of Minnesota appropriated \$10,000 for the erection of a Students' Observatory at the University of Minnesota. The building is already under roof and is promised for use by the first of January. The equipment will include a ten-inch equatorial of 150 inches focal length. This instrument is to have three objectives, one combination of which forms the visual telescopic objective and another the photographic objective. There are also three eye pieces of different magnifying powers, a filar micrometer and a driving clock. Two reading microscopes are provided for reading the declination circles, and the guiding telescope is of four-inch aperture. A spectroscope and photograph measuring machine are among the instruments soon to be added. Upon the completion of this working observatory Prof.

Leavenworth will offer courses in astronomy in advance of those which are now in the curriculum of the institution.

DR. H. P. JOHNSON, Harvard '90, Chicago '94, succeeds Mr. J. J. Rivers as Curator of the Museum of the University of California. Dr. J. C. Merriam, Munich '93, has been appointed instructor in paleontology.

PROF. JEROME H. RAYMOND, formerly of the University of Chicago, has been appointed professor of sociology and secretary of the University Extension Department of the University of Wisconsin.

THE will of Rev. John H. Duggan of Waterbury, Conn., leaves his library to the Catholic University of America at Washington, D. C.

DR. FREDERICK H. WINES has been appointed lecturer on social classes and social evils in Harvard University.

THE Agassiz professorship of Oriental languages at the University of California has been filled by the election of Dr. John Fryer, who has been for many years and is now a translator in the service of the Emperor of China. Dr. Fryer assumes his new duties the latter part of the present term or early in the next.

DR. HARRY MARSHALL WARD, Sc.D., F. R.S., of Christ's College, professor of botany at the Indian Engineering College, Cooper's-hill, has been elected to the chair of botany in the University of Cambridge, vacated through the death of Prof. Babington. The following particulars concerning Dr. Ward's work in botany are taken from the *London Times*:

Dr. Ward graduated B.A. as a member of Christ's College, obtaining a first-class in the Natural Sciences Tripos, 1879, with distinction in botany. In 1883 he was elected to a Fellowship, and in 1888 was elected a Fellow of the Royal Society. After taking his degree at Cambridge he devoted himself with ardour and success

to research. He, at the invitation of the Ceylon government, investigated the disease which about the year 1880 devastated the coffee plantations of Ceylon. His account of the life-history of *Hemilia vastatrix*, the fungus which immediately caused the disease, while contributing many new morphological and physiological facts, was especially valuable by reason of the scientific basis it established by which the method of the treatment of the disease that might be adopted should be founded. In 1889 he contributed a paper to the Royal Society 'On the tubercles in the roots of leguminous plants, with special reference to the pea and the bean.' In the following year, 1890, he was selected to deliver the Croonian lecture before the Royal Society, and selected as his subject 'The Relations between Host and Parasite in certain Epidemic Diseases of Plants.' In 1891 his paper on 'The Ginger-beer Plant and the Organisms composing it, a Contribution to the Study of Fermentation Yeasts and Bacteria,' attracted much attention, and was described by Lord Kelvin as a model of experimental biological investigation. In 1892 he contributed an important paper, entitled 'Experiments on the Action of Light on Bacillus Anthracis.' A further paper on the same subject was written by him, and later, in conjunction with Mr. P. F. Frankland, he contributed to the second report of the Water Research Committee of the Royal Society a paper entitled 'The Vitality and Virulence of Bacillus Anthracis and its Spores in Potable Water.' In 1893 the Royal Society recognized his great merit as an investigator by awarding him a Royal medal, and the President of the Society (Lord Kelvin) especially alluded to Prof. Ward's contribution on the action of light in arresting the development of and killing bacteria as having brought out striking results, the significance of which, from a sanitary point

of view, was sufficiently apparent, and, further, had led to other investigations by Prof. Ward into the wide question of the function of color in the vegetable kingdom. These further investigations were communicated to the Society in 1894 and form a part of the third report of the Water Research Committee. It may be mentioned that the value of the professorship is £700 a year, and it is tenable for life, subject to certain regulations as to residence and delivery of courses of lectures.

At the meeting of the University Court of Glasgow University, according to *The Lancet*, a letter was received from Mr. C. W. Mitchell, who quotes from a letter to Sir W. Geddes, written by the late Dr. Mitchell, who said: "Lord Huntly, I believe, is endeavoring to raise a special fund of £20,000, and if £6000 of that amount can be collected soon I would be prepared to contribute an additional £4000; further, if his lordship can increase his collection in £10,000 I will increase my subscription to £6000, thus making up the required £16,000 without appeal to the Government." "I now beg to confirm this offer," writes Mr. Mitchell, "subject to the consideration that your lordship's £6000 is collected by January 1, 1896, and the additional \$4000 by May 1st."

MR. JAMES WILSON, lecturer in agriculture at the University College of Wales, has been appointed to a similar lectureship in Glasgow University.

DR. OSTMANN, of Königsberg, has been appointed extraordinary professor of otology in succession to Professor Barth, who goes to Breslau.

DISCUSSION AND CORRESPONDENCE.

EXPERIMENTAL PSYCHOLOGY IN AMERICA.

TO THE EDITOR OF SCIENCE: I think my Journal, where the misunderstood words appeared, and where their context could be seen, should have had a chance to print the well concerted

quartet of letters in your issue of November 8. I see no ground for invoking the larger public of SCIENCE. Accepting, however, the change of venue, permit me to say, first, I never dreamed of disparaging a rival journal, or of implying in the remotest way either that mine was or even that the *Review* was not an *Archiv*. The reference was solely to the twice-considered plan of dropping all reviews, notes, etc., from the Journal and printing only researches as long, perhaps, as those lately printed separately by Profs. Cattell, Fullerton, Nichols, Brandt, etc.

Still less, if possible, did I dream of making or implying any claim so preposterous as that I or the Journal had 'accomplished nearly everything' 'for the advancement of psychology in America.' In the development of a new academic 'department' a crucial point is, as I deem it, when an instructor is appointed whose central work and interest is in that line. Such a point, I think, was marked both at the University of Pennsylvania and at Columbia by Prof. Cattell's appointment; at Wisconsin by Prof. Jastrow's; at Toronto by Dr. Kirschmann's; at Harvard by Dr. Nichols'; at Yale by Dr. Scripture's, and long ago at Johns Hopkins by my own. This, and this alone, was my theme. Had it been of the pioneer work, no less crucial, which made these appointments possible, which was done by Profs. James, Ladd, and earlier by President McCosh and others, I should not only have desired to say nearly all they have said, but more. To Prof. James, especially, I owe a debt I can never repay, unless by trying to influence him to correct the views in which we more and more widely differ, some of which he will bear me witness I have earnestly tried to do.

I am very sorry the name of Toronto got on the list of laboratories affected by our work. It is a mistake I cannot account for, and I am glad to correct the error with due apologies to all aggrieved thereby. The difference too between the wording of the relation between the assistant editors and myself, Dr. Sanford desires me to state, was his regrettable mistake, and will be corrected, according to the original announcement, in the next number.

As to the comparative influence of Yale and Clark upon men who have attended both, I

prefer to yield all claims rather than divide the child; so I do as to Dr. Scripture, and also as to the size of my 'influence' at Princeton. As Socrates said of the disputations of the sophist Euthydemus, I would rather be refuted by such arguments than to use them.

For one, I sincerely hope that in this transition period the psychological atmosphere will not become too tense for a spirit of hearty coöperation, or too lax for healthful or virile competition.

G. STANLEY HALL.

CLARK UNIVERSITY, November 18, 1895.

THE BREHM CUTS AGAIN.

TO THE EDITOR OF SCIENCE: Referring to SCIENCE of April 5, 1895, p. 387, and June 21, p. 682, I beg to say that my original charge of libel against Dr. C. H. Merriam, for using the term 'piracy' in connection with the appearance of the Brehm cuts in the *Standard Natural History*, is not in the least affected by what appears in SCIENCE of October 25, 1895, p. 648. I believe the latter to be substantially correct; but it relates to an entirely different matter, viz.: action brought to recover damages for alleged breach of contract concerning resale of Brehm cuts and their subsequent use in other connections than the *Standard Natural History*. The case will be found fully and no doubt fairly stated in the Publishers' Weekly of October 26, 1895, p. 716; but it is one that I never raised, and know nothing about—only that it has nothing to do with the point I made; and I should not now bring it up again, except to correct a very possible misapprehension on the part of some who may be misled into the belief that my original charge does not remain in full force.

ELLIOTT COUES.

WASHINGTON, D. C., November 17, 1895.

QUATERNIONS.

EDITOR OF SCIENCE:—The communication in a recent issue of SCIENCE in reference to the formation of an International Society for the purpose of advancing the study of Quaternions is one of great significance to the friends of the subject in this country. The time is certainly fitting for the organization of such a society and

the suggestion should meet with a generous response. The project already has the support of Profs. Tait and Laisant and will, no doubt, be aided by the leading advocates of Quaternions everywhere. The movement should be encouraged in every possible way.

VICTOR C. ALDERSON.

ARMOUR INSTITUTE OF TECHNOLOGY, CHICAGO.

SCIENTIFIC LITERATURE.

The Forces of Nature. By HARROP and WALLIS.

Published by the same, Columbus, Ohio. Pp. 160, 12 mo.

The reading of this book gives rise to a feeling of wonder; wonder that it was ever written; wonder that it was ever published and wonder that it should ever be read. About half of it is included in five chapters on 'The Solar System;' 'The Atmosphere—Sound;' 'Chemistry—The Structure of Matter;' 'Radiant Energy—Light, Heat and Actinism;' 'Electricity—Magnetism.' These are large subjects, but the authors of this book do not shrink from the task, self-imposed, let us hope, of treating them in about seventy pages of large type and fair leading. Their aim has been, as stated in the introduction, to present 'the great fundamental principles of the Earth's science and the laws which govern the operations of Nature.' The importance of this presentation is forcibly shown in the following paragraph from the preface of this book: "All natural phenomena are explainable upon the simple laws of mechanics. These laws govern alike the systematic motions of worlds and the complicated functions of organic life. It only remains, then, for the reader to make himself conversant with the fundamental principles upon which the system hinges to comprehend the harmony of all things in nature." The preface further recognizes 'a class of persons who have acquired a thorough knowledge of their special callings' who unquestionably hunger after a knowledge of these fundamental principles and who desire to satisfy their ravenous appetites 'without tedious delving amongst learned volumes which they have probably neither the time nor the inclination to read.' For these the authors have written this book. It is not worth while to consume time and space in giving extensive references to its con-

tents. Nine of its pages suffice for the consideration of the solar system, including a special study of the Earth. In the chapter on chemistry one or two great fundamental principles are let loose, including the statement that ice continues to expand as its temperature is lowered, and it is on account of this expansion that water pipes are burst. In the chapter on Radiant Energy we are distinctly, almost defiantly, informed that "Polarized light has some application in Optics and Qualitative Analysis," and also that when air is compressed "the molecules are moved into such close proximity as to be unable to retain all their former motion—heat—a portion of which is delivered up to external objects either by conduction or radiation." In accordance with the plan outlined in the introduction, having in the first seventy pages disposed of the 'general aspects of nature,' the remainder of the book is devoted to a 'more particular exposition of underlying principles' as put forth in 'a series of disconnected paragraphs and essays.' Here the authors toy with 'Life on the Planet Mars;' 'Spontaneous Generation;' 'The Incandescent Lamp;' 'Argon,' etc., etc., etc., forming almost as great a variety as the contents of a modern Sunday newspaper.

In their introduction they remark that 'the necessity for *consecutive* reading' cannot be too strongly urged; the common tendency to 'skip' is deplored and the reader is urged 'to proceed slowly, being sure that he understands each paragraph before leaving it.' That interesting class for whom the book is intended, 'persons who have acquired a thorough knowledge of their special callings,' will doubtless be able to understand the, to others rather obscure, relation between 'Life on the Planet Mars' and 'Death by Lightning,' which makes a certain order of reading necessary. To the ordinary reader of the Astronomical news of the past year or two, the latter might be chosen first, last and all the time.

A really serious aspect of this case is the announcement that the authors have in press a second volume on 'The Forces of Life,' which is to be 'a study of Organic Nature,' and which is to discuss the Classification of Species, Evolution, Paleontology, Morphology, Embryology, the origin of cell life, etc. If these youthful

Encyclopædists (it is difficult to imagine them to be anything else than youthful, no matter how many years they may have lived), will hold themselves in check until they learn something that other people do not know, or until they learn what other people do know so well and so clearly that they can claim some right to classify, edit and arrange existing knowledge, they will confer a favor upon themselves the magnitude of which it is difficult to estimate.

Alternating Electric Currents. By EDWIN J. HOUSTON and A. S. KENNELLY. New York, The W. J. Johnston Co. Pp. 225. Price \$1.

This little volume forms one of the "Electro-Technical Series," of which nearly a dozen volumes have been prepared by Messrs. Houston and Kennelly. It treats of one of the most important and most prominent departments of applied electricity. The development of the theory of Alternating Currents and their practical utilization is of comparatively recent date. The large pecuniary interests involved in the various processes by which energy is transformed have put a premium upon the exploration and exploitation of this branch of physical science such as no other has ever felt. Workers in science generally are sustained by that motive and inspiration which compels the practical geographer to force his way into and through unknown regions, his reward being the knowledge of their nature and inhabitants, with which he is laden when he returns. In electricity there is the additional powerful incentive that gems and precious metals are tolerably sure to be met with. The science of electricity has prospered, therefore, during the last decade in a manner only equaled or excelled by its practical applications. Even the expert now finds it difficult to keep thoroughly informed of the rapid and often far-reaching advances that are continually being made. To the layman, or even to the general physicist, who has not been forced as, alas! nearly all have, to 'specialize' in electricity, any book which summarizes this progress in an intelligent and scientifically correct manner will be welcome. To such this book will be of much use. The conception of the alternating current is well worked out in the first chapter, and in those following its ap-

plication to the transmission of power and to electric lighting is discussed in a popular readable form, including a discussion of diphasé, triphasé and monocyclic currents and transmission. The principle criticism that may be applied to the book is the unnecessary presentation of a great deal of elementary matter, concerning which the reader is almost sure to be already well informed. It does not seem likely that any one who undertakes to read a book, be it ever so simple, on 'Alternating Electric Currents' will be entirely ignorant of a simple primary battery, of the form of an electric magnet, of the appearance and construction of an incandescent lamp, of which there is a long and elaborate description. The amount of ignorance which is here assumed is not quite in harmony with the amount of technical information which the reader must possess in order to understand other portions of the book. The volume could have been made more valuable by assuming on the part of the reader that knowledge of direct current electricity which he is tolerably certain to possess or which he can readily obtain from other volumes of the same series. There are certain advantages, it is true, in having each volume complete in itself, but these are greatly exceeded by the disadvantages growing out of the enforced buying, owning and reading the same matter over and over again.

THE MAGNETIC RESURVEY OF AUSTRIA AND HUNGARY.

FROM a recent report* by Dr. Liznar, of the 'Central Anstalt für Meteorologie und Erdmagnetismus' of Vienna, we find that the recent magnetic resurvey of Austria and Hungary (1889-'93) has been brought to a termination. An earlier magnetic survey had already been made by Karl Kreil between the years 1843 and 1858, which was repeated a few years later,

*J. Liznar: Die Vertheilung der erdmagnetischen Kraft in Österreich-Ungarn zur Epoche 1890.0 nach den in den Jahren 1889 bis 1894 ausgeführten Messungen. 1 Theil, Erdmagnetische Messungen in Österreich ausgeführt auf Kosten d. Kais. Akad.: d. Wiss. in d. Y. 1889-'93, von J. Liznar. Wien, 1895, 4°, 232 pp. Repr. Denk. d. Wiener Akad. Math. naturw. Cl. Bd. LXII.

as far as Hungary was concerned, by Guido Schenzl. On account of the slow, so-called *secular changes*, whereby the distribution of terrestrial magnetism is forever changing its present aspect, it becomes essential to repeat such surveys from time to time. We are thus enabled to follow empirically, at least, the *modus operandi* of that occult, elusive force—the cause of the secular variation of terrestrial magnetism.

Other reasons make it desirable to repeat and amplify former surveys. Not only are our present methods of observations more refined, but experience has repeatedly taught that a magnetic chart based upon a few isolated observations gives but a very crude picture of the actual distribution of magnetism within the earth's crust. The complexity of the picture or the irregularity of the representative distribution curves furnishes, generally speaking, the truest index of the thoroughness of the underlying survey.

The first part of the report before us, of which the second is to appear later, is devoted to the publication and reduction of the observations made in Austria by Dr. Liznar, under the auspices of the Vienna Academy of Sciences. On pp. 230 and 231 is given in alphabetical order the 109 observation stations, together with their geographical positions and the observed magnetic elements reduced to the epoch 1890.0. The intensities (horizontal and total) are given to four decimals in mm. mg. s. units—a simple division by 10 will reduce to c. g. s. units.

The discussion of the results and the delineation by charts of the magnetic distribution are reserved for the second part, which is also to contain the observations made by previous agreement during the same time interval along the Adriatic coast by the Hydrographic office of Pola, and in Hungary by the Central Meteorological and Magnetic Institute of Budapest. Great care was taken that observations thus made under different auspices should be strictly comparable. Frequent inter-comparisons of the instruments used were made by selecting common observing stations, as also were the instruments compared with those at the Central Institute.

Two points are suggested by this report, the

first of which may perhaps appear trivial, but from which we, nevertheless, might draw a useful lesson. This report, like many others of a scientific character, received from abroad is above all *well printed*, a fact which is not characteristic of some of our scientific government publications, whose typographical execution in several notable instances has been abominable. We believe that what is worth doing at all is not alone worth doing well, but also *printing well*. Too often the character of the contents is judged by the external appearance.

The second point suggested is the great desirability of a detailed magnetic survey of our own confines. Our Coast and Geodetic Survey is doing excellent work in this direction, but the comparatively few observations, if you consider the territorial extent involved, it can make with all its manifold other duties, are wholly inadequate for a fairly accurate representation of terrestrial magnetic distribution in the United States. How fraught with problems of the most interesting and suggestive character a *detailed* magnetic survey can present to the physicist and to the geologist has been clearly shown by the Rücker and Thorpe minute magnetic survey of Great Britain.

At the present time when many of the European governments have either just carried out detailed surveys or are about to do so, it behooves us to fall in line. But *one* State of the Union has received the distinction of having a fairly complete magnetic survey made of it, and this was due to the *private* enterprise and enthusiasm of Prof. Francis E. Nipher, of Washington University, St. Louis. Good work has also been accomplished in this direction by the geologists in New York, New Jersey and Pennsylvania. It is firmly believed that more of such detail work will redound to the benefit of geology and of geomagnetism.

L. A. B.

Tables for the Determination of Common Minerals.

By PROF. W. O. CROSBY, of the Mass. Inst. of Technology.

This book, the third edition of which has just been published (1895), is a very carefully prepared scheme for the determination of about two hundred and twenty-five of the more com-

mon mineral species, chiefly by means of their physical properties with confirmatory chemical tests. A special feature is the addition of a supplemental table for the determination of one hundred of the rarer minerals, thus avoiding for the student the unnecessary use of a large cumbersome scheme, and at the same time reducing to a minimum the chances of meeting a mineral not contained in the Tables.

The general idea of the scheme is to make two grand divisions into the minerals *with* and the minerals *without metallic lustre*. The minerals having *metallic lustre* being further sub-divided into groups by their *color* and approximate *hardness*. The minerals with *non-metallic lustre* being grouped by color of *streak*, approximate *hardness*, *specific gravity* and general structure.

These Tables carry out the idea that a scheme is the *better*, the more closely it tends to facilitate recognition of minerals at sight by their structural and physical characters. For this reason chemical tests are only used as confirmatory and are made as simple as possible, so as to put them within the reach of persons having only a blowpipe outfit. Schemes of this character can be used with great success by students who are more or less proficient in mineralogy, and who have been carefully trained in observation. One part of the scheme that might give trouble to beginners is the required determination of the specific gravity of the non-metallic minerals. A determination for which special apparatus is needed and which is generally more or less difficult. Schemes for the non-metallic minerals based on fusibility and solubility, especially when dealing with massive minerals, may give more general satisfaction when used by beginners.

The introductory part includes a detailed description of the morphological, physical and chemical properties of minerals, and a short explanation of the blowpipe tests made use of in the Tables. A simple and inexpensive form of specific gravity apparatus is also described. A list is furnished the student of fifty of the common minerals, giving very characteristic tests and most useful in commencing a course of determinative mineralogy.

A very convenient chapter is that on 'How to use the Tables.' Here the structural, physi-

cal and chemical properties of several minerals are given, and the student is taken, step by step, by reference to page, etc., through the actual determination or confirmation of the mineral. A great advantage in this scheme is having the general synopsis all contained on one page, after reference to which it is generally possible to turn immediately to the part of the Tables needed for the determination of the special mineral in question.

The separation of the scale of hardness into five divisions instead of ten also has its advantages, as it makes possible the use of the Tables when only an approximate determination of the hardness has been made.

After each mineral species in the Tables a number, in parenthesis, is given, which refers to the synopsis of classification where at a glance the general relation of the special mineral to the rest of the mineral kingdom is given.

At the end of the Tables a very convenient index of mineral names and synonyms is found.

LEA MCI. LUQUER.

Fauna fosil de la Sierra de Catorce, en San Luis Potosí. AGUILERA Y DEL CASTILLO. Boletín de la Comision Geologica de Mexico. No. 1, Mexico. 1895. Pp. 55, plates xxiv.

In this publication, the authors confirm the existence of the Jurassic System in Mexico. They note that the formation has a vast extent, greater than is commonly believed, partly for the reason that the localities are widely separated and difficult of access. The fossils also are scarce and not well preserved. Another circumstance which appears to be unfavorable to the recognition of the system is its gradual passage into the overlying Cretaceous. This transition zone is barren of fossils or at best contains forms which are of difficult interpretation. The Jurassic rocks belong mostly to the upper division, but localities exist in which strata are found representing the middle and lower members. Some authors, deceived by the resemblance of the Cretaceous limestones to those of the Jura, have referred these deposits to the Jurassic, but our authors have referred them on the evidence of their contained fossils to the Cretaceous on the geological map of the Republic.

The Jurassic fauna consists largely of species apparently peculiar to Mexico. It is characterized by numerous forms of Aucella and Perisphinctes, about half of which are described as new species. This paper, following so soon after the discoveries of Diller and Hyatt in California, is of much interest to American geologists.

The authors have been unfortunate in the hands of their lithographer. The plates are of little use; some of the figures are scarcely recognizable.

J. B. WOODWORTH.

An Introduction to General Biology. SEDGWICK and WILSON. Second Edition. 1895. New York, Henry Holt & Co.

The original Practical Biology of Huxley and Martin, written in 1875, has stimulated the production of a large growth of text-books and laboratory manuals. Huxley and Martin attempted to present the fundamental facts of biology to the student by the study of a series of typical animals and plants, beginning with the simplest and ending with the more complex. Nevertheless, this logical method proved impractical and in a later and too-much enlarged edition the authors (or rather their successors, with Huxley's approval) reversed the order of treatment of the subject. The higher forms were first studied and then the student was led down through a series of simpler forms. Huxley said, however admirable the first method followed by him had been 'it had its defects in practice.'

Sedgwick and Wilson adopted, in 1886, a third order of procedure in the first edition of their General Biology. Two common forms, the fern and the earthworm, were first thoroughly described as introductory to a later study of other animals and plants; and a second volume was promised, dealing with the other forms. This second part has never appeared and its publication has been finally abandoned.

A second edition of the General Biology of Sedgwick and Wilson has just come out and will be welcomed by all those who have learned through experience the great value of the first edition.

In the present edition the principal changes

are as follows: (1) The book has been enlarged so as to include a series of unicellular forms (Amœba, Infusoria, Protoecoccus, Yeasts, Bacteria). (2) The laboratory directions given in the first edition have been omitted. In their place an admirable appendix has been added. The appendix describes the best methods in preserving and preparing the forms described in the text; a large number of valuable and practical suggestions are also added. (3) The order of presentation has been reversed. The earthworm now comes first and then the fern follows.

In the first edition, and in the present edition also, the student is introduced to the subject of General Biology by a chapter dealing with the differences between living and lifeless things, 'believing that Biology should follow the example of Physics and Chemistry in discussing at the outset the fundamental properties of matter and energy.' If we consider, however, the unsettled state of mind of biologists at present on these fundamental questions and, further, the presumed ignorance of the student of all knowledge of living things we cannot but think this method of presentation open to question.

The next two chapters in the present edition, following the order of the first edition, deal with a study of a series of heterogeneous objects illustrating 'the structure of living things' and 'protoplasm and the cell.' The *pièce de résistance* is then introduced.

The reason assigned by the authors for offering first the earthworm 'lies in the greater ease with which the physiology of an animal can be approached.' However true this may be from the student's standpoint, it presents certain difficulties to the conscientious teacher, for in reality very little physiology is actually known for the earthworm, 'save by analogy with higher animals.'

For ourselves, we prefer *at present* the old sequence with the plant first and the animal later, admitting wide scope for individual taste. Practically, we have found that the new edition adapts itself to our own idiosyncrasies and works backward just as well as forward.

Most important additions and corrections have been made to the description of the structure of the earthworm. The accounts of the circulatory and nephridial systems have been

extended. The former imperfect description of the male reproductive organs has been corrected. The histology of the nervous system is more fully described and the results brought up to date according to Retzius and Lenhossék.

The description of the development of the earthworm from the egg is more fully given, and a description of the internal phenomena of cell-division is added.

The process of regeneration in the earthworm is incorrectly, or at least very imperfectly, described. "The earthworm is not known to multiply by any natural process of agamogenesis. It possesses in a high degree, however, the closely related power of regeneration; for if a worm be cut transversely into two pieces the anterior piece will usually make good or regenerate the missing portion, while the posterior piece may regenerate the anterior region" (page 73). Rarely or never will this happen in the earthworm! If the anterior piece be sufficiently long, *i. e.*, if it contains more than 24 segments it may then regenerate posteriorly. But the corresponding posterior end will not under these conditions regenerate. A shorter anterior piece will not regenerate. A posterior piece having lost less than 15 anterior segments may regenerate and replace all or part of those lost.

Few and unimportant changes seem to have been added to the description of the structure and physiology of the fern.

The brief descriptions of the unicellular forms are most admirable and a most important addition has been made to the older volume. A statement in the chapter devoted to yeast calls for correction (page 188). "It was supposed for a long time by Pasteur and others that yeast could dispense with free oxygen in its dietary. It now appears that this faculty is temporary only." * * * Pasteur himself on the contrary has given the results of a most elaborate series of experiments to demonstrate that yeast can not permanently dispense with free oxygen in its dietary.

Chapter XVI on bacteria and Chapter XVII on 'a hay infusion' give in few words a thoroughly good summary of the part played by bacteria in the world's economy.

The first edition of the General Biology filled

a unique place amongst our text-books and the new edition fulfills all the uses of the first edition. It brings the latter down to date and we venture to prophesy that it will meet with a hearty reception. The volume is a much-needed and most valuable addition to our best text-books. It is well printed and illustrated, and the descriptions of the authors are always clear and concise. T. H. MORGAN.

SCIENTIFIC JOURNALS.

AMERICAN CHEMICAL JOURNAL, NOVEMBER.

JACKSON and Grindley contribute further results of their work on the action of sodic alcoholates on chloranil. They describe the methods of preparation, properties and reactions of a number of acetals derived from substituted quinones.

Orndorff and Cameron find that the substance formed by the action of sunlight on anthracene in benzene, is dianthracene and not a paranthracene. They obtained the substance in pure condition and made a thorough crystallographic study of it. Interesting points of resemblance and difference were brought out by a comparison of the measurements of the axial ratios and angles. All attempts to bring about the transformation by any other method than that made use of failed.

Hitherto all the determinations of the molecular weight of paranthracene have been made by the freezing-point method. The vapor-density method could not be used, as paranthracene is converted into anthracene at its melting point (244°). The results obtained by the freezing-point method varied greatly, and were very unsatisfactory, on account of the slight solubility of the substance in all the solvents used. The authors find that, by the use of the boiling-point method, using pyridine, anisol and phenetol as solvents, good results can be obtained.

Campbell has prepared copper oxide containing a small amount of palladium, and finds that the combustion of gases takes place at a lower temperature when he uses this mixture than when the oxygen is introduced in the form of gas.

Kastle suggests the use of the dichlor deriva-

tive of benzene sulphonamide as a reagent for bromine and iodine, in the place of chlorine water. When metallic bromides or iodides are decomposed by this substance, in the presence of carbon disulphide or chloroform, the solvents are colored, as they are when chlorine water is used. The substance is very stable and the reaction is extremely delicate.

Kremers has studied the effects of solvents upon the rotatory power of limonene. In some cases, as the dilution increases, the rotatory power of the limonene diminishes. He also found that limonene monohydrochloride, when in contact with water in a sealed tube, was slowly charged to terpin hydrate.

By the action of bromine on metanitriline, Wheeler obtained a substance in which the bromine is in the ortho position to the amido group. The nitro group influences the substitution in this case, for if aniline is treated with halogens, para and not ortho compounds are obtained. A number of derivatives of metanitriline were made and studied. A review of recent articles on the dissociation of electrolytes as determined by experiments on solubility, is contributed by Humphreys.

J. ELLIOTT GILPIN.

SOCIETIES AND ACADEMIES.

NEW YORK ACADEMY OF SCIENCES, BIOLOGICAL SECTION, NOVEMBER 11, 1895.

THE following papers were presented:

Prof. H. F. Osborn: 'A Memorial Tribute to Prof. Thomas H. Huxley.'

Dr. Bashford Dean: 'Notes of the Ancestral Sharks.' In this paper Cladoselachids were reviewed, and for the first time the structural characters of their vertebral skeleton, integument and suspensorium were given; and together with these features was noted the lack of claspers, shown in a dozen well-preserved ventral fins, as significant of the fertilization conditions of these early sharks. In this regard these Lower Carbon forms would correspond to the usual ichthyic type (as of Teleostome or Lung-fish). The total absence of a pelvic girdle in these early forms is also significant.

Dr. Arnold Graf: 'A Peculiar Growth Char-

acter in *Crepidula*.' This paper recorded the adjustment of the shell of the *Crepidula* to that of a scallop, *Pecten*, the margin of the shell of the *Crepidula* conforming exactly to the ridged character of the shell of its host.

BASHFORD DEAN,
Recording Secretary.

THE TORREY BOTANICAL CLUB.

At the regular meeting of the Club held on Tuesday evening, November 12. Prof. Emily L. Gregory, Ph. D., of Barnard College, presented an historical sketch of the *Theories of the Origin and Nature of the Starch Grain*, the relations of our present views concerning the nature of growth of organized matter to these theories being specially dwelt upon.

The systematic study of the subject began with Nægeli, and all subsequent contributions were either based upon his conclusions or took them for the starting point. He recognized the two substances, starch-cellulose and granulose as composing the starch grain, and described the phenomena of the appearance and disappearance of the latter and the transportation of its substance. He referred its origin to the chlorophyll-grain. Schimper subsequently pointed out the existence of the two other bodies, leucoplastids and chromoplastids and traced relations between the former and the starch grain. In all work up to and including that of Schimper, the accepted distinctions between unorganized and organized matter were such that the starch grain was taken as the type of the latter, and Schimper denominated it as crystalloid substance; that is, one which, though really organized, resembles a crystal in some particulars. Observations of the phenomena of the starch grain thus became the basis for theories concerning the growth of organized substances, of which the starch grain was taken as the type. Recently, however, Meyer has published a work reviewing the subject, and demonstrating, apparently, that it is not a crystalloid, but a true crystal, hence unorganized; so that all theories of the growth of organized substance, based on our ideas of the starch grain fall, and we must begin to study the subject *de novo* if Meyer's views are correct.

H. H. RUSBY, *Rec. Sec.*

NATIONAL GEOGRAPHIC SOCIETY, REGULAR
TECHNICAL MEETING, WASHINGTON,
D. C., FRIDAY EVENING, NO-
VEMBER 15.

The meeting was devoted to the discussion of the subject of the hydrography of the United States, in which five Government officers engaged in that work took part.

Mr. F. H. Newell, in charge of the Division of Hydrography in the U. S. Geological Survey, referred to the hydrographic work done by the Government through the agency of the Coast and Geodetic Survey, the Hydrographic Office, the Engineers' Office of the Army, and one or two other organizations, and pointed out the difference between that work and the work of the Geological Survey, the work of the organizations first named having reference in the main to the interests of commerce, while that of the last named Bureau is for the purpose of obtaining data of value relating to land irrigation, water power, and the supply of potable water. He then discussed in general terms the important work that the Geological Survey is doing in this line, with the small appropriation that it has for the purpose, and the methods followed.

Mr. Newell was followed by Prof. Willis L. Moore, Chief of the Weather Bureau, who outlined the objects and methods of the work of the flood-forecasting division of his Bureau in forecasting floods on the principal rivers, giving instances of how the people in certain regions had been warned of approaching floods, and how many lives and millions of property had thus been saved. He referred to the limited scope of the work, due to lack of funds.

Prof. Moore was followed by Mr. A. P. Davis and Mr. Cyrus C. Babb, both of the Geological Survey, in charge of stream measurements in the West and in the South and East, respectively. Mr. Davis stated the conditions which had governed the location and selection of gauging stations, mentioning State and private cooperation, necessitated by demands of economy, and describing the hydrographic basins, etc. Certain railroads and irrigation companies, he said, are making systematic stream measurements in the West. Two States, Kansas and Colorado, are cooperating by devoting a small sum of money to the work. Mr. Babb similarly

discussed the work done in connection with the streams of the Southern Appalachian region and on the Potomac. His work, which was begun but a few months ago, is the first of the kind yet done in the southern part of the country, and his paper was of particular interest.

The meeting closed with a paper by Mr. Marcus Baker, formerly of the Coast Survey, on the hydrography of the navigable waters, which was an interesting presentation of the subject from the point of view of navigation and commerce.

W. F. M.

GEOLOGICAL CONFERENCE OF HARVARD UNIVERSITY, NOVEMBER 5, 1895.

The Great Barrier Reef of Australia. By J. B. WOODWORTH. Mr. Woodworth spoke of the work of Mr. Saville Kent. A selection of about forty stereopticon views from the set of photographs of the great coral reef was shown. The views, it was pointed out, illustrated the way in which lowly-organized animals in coral seas take the place of plants, and even of inorganic debris on coasts like those of New England. The leafy alcyonarians grow attached to the bottom and act as the sea-weeds do in fending off the waves, and in harboring free crawling forms of marine life. The coral heads and blocks torn up by hurricanes take the place of boulders along the shore line. This reef further shows how great limestones, such as the Trenton and Corniferous of the North American palaeozoic sea, could have been made at no great distance from land. The great limestone-making zone is at sea level and a few feet below. The conditions now existing in the Great Barrier Reef, where islets and lagoons form, permit of the existence of land vegetation, and the record of various forms of shallow water and surface species in the midst of processes of limestone-making, which geologists have been accustomed to consider indicative of deep sea. It is now clear, as Dr. Murray has pointed out, that there are two great classes of marine calcareous deposits; those of the deep sea proper not developed in the continental areas, except locally, and those of a strictly continental type, of which the fossil reefs of the New York State system and the Great Barrier Reef of Australia are past and present examples.

Notes on Geological Excursions. By W. M. DAVIS. 1. A brief description was given of an excursion made on October 26th with a party from the Teachers College, New York City, up the Hudson River Railroad to Fishkill, and thence by electric car and on foot to the summit of South Beacon Hill (1635), near the northern margin of the Highlands. The evenness of the sky-line was a notable feature of the view then obtained, the successive ridges reaching a much more equable altitude than, for example, in the Highlands of Scotland; although both regions are regarded as ancient lowlands, reduced to moderate relief by long-continued denudation, afterwards elevated and dissected. The Highlands of the Hudson are now advanced well towards mature variety of form in the present cycle of denudation, the valleys generally following an Appalachian trend, northeast-southwest. The view included the trench cut across the Highlands by the Hudson, an admirable example of a narrow transverse valley draining a wide inner longitudinal valley; the deepening of the inner valley was permitted only as fast as the trenching of the transverse valley advanced, but the widening of the inner valley proceeded rapidly because the rocks there are relatively weak, while the transverse valley is still narrow, inasmuch as the rocks in which it is sunk are extremely resistant. The movement of elevation permitting the dissection of the Highlands paused before their present altitude was reached, as is indicated by a more or less persistent bench about 150-200 feet above the present river level, first brought to the writer's attention by Mr. Gilbert. West Point is on this bench.

2. Some account was given of a two-day excursion, November 2d and 3d, with a party of Harvard students to the district about Meriden, Conn., where the contact of basal Triassic conglomerates on ancient schists in the gorge of Roaring Brook, Southington, the two lava beds of the Meriden quarries, and the oblique 2000-foot fault from Meriden to Berlin, were examined. The evidence of two cycles of topographical development was reviewed from the summit of West peak (1007 feet) in the Hanging hills. The crystalline uplands on the east and west represent a peneplain of Jurassic-Cre-

taceous denudation, now uplifted and dissected by narrow valleys of adolescent expression; the broad floor of the Triassic lowland between the crystalline uplands represent a local peneplain of late Tertiary denudation, here and there interrupted by narrow lava ridges. The crest line of Totoket Mountain, next to the southernmost of the eastern lava ridges, is notable for its evenness. Mount Carmel and the Blue Hills, an ancient volcanic neck north of New Haven, rise somewhat above the level of the adjacent crystalline upland. The inland facing escarpment, or *inface*, of Long Island rose faintly on the southern horizon; the stripped lowland between its inner base and the crystalline old land being now submerged in Long Island sound. The glacial striae ascending the north slope of the West peak lava ridge for at least a mile, now freshly revealed along the road lately made to 'Percival Park' on the summit, are commended to the attention of those who hesitate to believe that ice sheets can move up hill. (An account of the double lava bed of the Meriden quarries will appear in a forthcoming number of the American Journal of Science.)

ACADEMY OF SCIENCE, ST. LOUIS, NOV. 13, 1895.

THE Academy held its regular meeting at the Academy rooms, with President Green in the chair, and twenty-two members and visitors present.

Dr. Noah M. Glatfelter read a paper on 'The Relations of *Salix Missouriensis* Bebb, to *Salix Cordata*.' Dr. Glatfelter stated that *Salix Missouriensis* had been classed as a separate species by Mr. M. S. Bebb, but his own researches resulted in a different conclusion, his belief being that *Salix Missouriensis* was but a variety of *Salix Cordata*, and in some instances it was impossible for him even to detect the variety, the two being seemingly identical. Referred to the Council.

Mr. F. W. Duenkel presented a model of a meteorological instrument, invented by Mr. Leonard Hunt and himself, called 'The Electric Sunshine Annunciator,' and gave a brief explanation of its mode of operation, stating that it had been in use for a short time, but reported with accuracy the amount of sunshine each day.

A. W. DOUGLAS, *Recording Secretary.*

SCIENCE

NEW SERIES.
VOL. II. No. 49.

FRIDAY, DECEMBER 6, 1895.

SINGLE COPIES, 15 CTS.
ANNUAL SUBSCRIPTION, \$5.00.

GUSTAV E. STECHERT'S Recent Importation of Scientific Books.

APEL, DR. MAX. Kants Erkenntnistheorie u. seine Stellung zur Metaphysik. Eine Einführung in d. Studium von Kants Kritik der reinen Vernunft. 147 Seiten. 8°. Mk. 3⁰⁰.

BAAS, J. HERM. Die geschichtliche Entwicklung des ärztlichen Standes u. der. medicinischen Wissenschaften. Mit 2 Abbildgn. 480 Seiten. gr. 8°. Mk. 11⁰⁰.

BIEDERMANN, W. Electrophysiologie. 2^o Abtheilung. Mit 149 Abbildungen. 857 Seiten. gr. 8°. Mk. 9⁰⁰.

BUCHKA, DR. KARL VON. Physikalisch-chemische Tabellen der anorganischen Chemie. 348 Seiten. gr. 8°. Mk. 10⁰⁰.

FUCHS, DR. GÖPFTOLD. Anleitung zur Molekular-gewichtsbestimmung nach der 'Beckmannschen' Gefrier- u. Siedepunktmethode. Mit 18 Text Figuren. 14 Seiten. Cloth. M. 1²⁰.

GERARD, ERIC. Mesures electriques. Leçons professées a l' institut electrotechnique 'Montefiore annexé a l' université de Liège, Avec 198 figures dans le texte. 457 pages. Cloth. Francs 12⁰⁰.

GOMPERZ, THEOD. Griechische Denker. Eine Geschichte der antiken Philosophie. 1^{ster} Band. 478 Seiten. gr. 8°. Mk. 10⁰⁰.

GRUNMACH, DR. LEO. Lehrbuch der magnetischen u. electrischen Maasseinheiten, Messmethoden u. Messapparate. Mit 342 in den Text gedr. Holzschnitten u. vielen Tabellen. 632 Seiten. Mk. 16⁰⁰.

HAMMARSTEN, OLOF. Lehrbuch der physiologischen Chemie. 3^{te} völlig umgearb. Auflage. Mit Spectral taf. 647 Seiten. gr. 8°. Mk. 14⁰⁰.

KIPPENBERGER, DR. KARL. Beiträge zur Reinsolirung, quantitativen Trennung u. chemischen Charakteristik von Alkaloiden u. glycosidartigen Körpern in forensen Fällen, mit besonderer Rücksicht auf den Nachweis derselben in verwesenden Cadavern. 58 Seiten. 8°. Mk. 1⁶⁰.

KISSLING, P. B. Beiträge zur Kenntniss des Einflusses der chemischen Lichtintensität auf die Vegetation. 28 Seiten. gr. 8°, mit 3 Platten. Mk. 3⁰⁰.

KRATZER, DR. JUL. Der Tod durch Electricität. Eine forensisch-medicin. Studie auf experimenteller Grundlage. Mit 7 Abbildgn und Tafeln. 159 Seiten. gr. 8°. Mk. 7⁰⁰.

LE BLANC, DR. MAX. Lehrbuch der Electrochemie. Mit 32 Figuren. 226 Seiten. 8°. Mk. 4⁸⁰.

LEVY, S. Anleitung zur Darstellung organisch-chemischer Präparate. 3^{te} neu bearbeitete u. erweiterte Auflage herausg. v. Dr. A. Bistrzycki. Mit 35 in den Text gedr. Holzschnitten. 210 Seiten. 8°. In paper, Mk. 4⁰⁰; in cloth, Mk. 5⁰⁰.

MÜLLER, E. Die vermeintlichen Inductionsstörungen im Fernsprechbetriebe u. deren Beseitigung. 65 Seiten. 8°. Mk. 2⁴⁰.

NERNST, W. U. A. SCHÖNFLIES. Einführung in die mathematische Behandlung der Naturwissenschaften. Kurzgefasstes Lehrbuch der Differential- u. Integralrechnung mit besonderer Berücksichtigung der Chemie. Mit 61 im Text befindl. Figuren. 309 Seiten. gr. 8°. Mk. 8⁰⁰.

OSTWALD, WILH. Die Ueberwindung des wissenschaftlichen Materialismus. Vortrag, gehalten i. d. Versammlung d. Naturforscher u. Aerzte zu Lübeck am 20^{ten} September, 1895. 36 Seiten. 8°. Mk. 1⁰⁰.

PAULSEN, DR. FRDR. Geschichte des gelehrten Unterrichts auf den deutschen Schulen u. Universitäten vom Ausgange des Mittelalters bis zur Gegenwart. 2^{te} umgearb. u. sehr erweiterte Aufl. 1^{ster} Halbband. 320 Seiten. gr. 8°. Mk. 7⁰⁰.

PLÜCKERS, JULIUS. Gesammelte wissenschaftl. Abhandlungen. Im Auftrage d. Kgl. Gesellschaft d. Wissenschaften zu Göttingen, herausgegeben v. A. Schönflies und Pockels. 1^{ster} Band. Mathematische Abhandlungen, herausgegeben von A. Schönflies. Mit einem Bildniss und 73 Figuren. 620 Seiten. gr. 8°. Mk. 20⁰⁰.

PREYER, W. Die Seele des Kindes. Beobachtungen über die geistige Entwicklung des Menschen in den ersten Lebensjahren. 4^{te} Aufl. 462 Seiten. 8°. Mk. 8⁰⁰.

SMITH, DR. AUGUST. Die Alkoholfrage u. ihre Bedeutung für Volkswohl u. Volksgesundheit. Eine social-medicinische Studie für Aerzte u. gebildete Laien. Mit 7 Abbildungen. 127 Seiten. 8°. Mk. 2⁸⁰.

SPRAUL, DR. ALEX. Erläuterungen zur qualitativen Analyse anorganischer Körper in Bezug auf die practischen Hilfsmittel u. den plannässigen Gang derselben. Mit 50 Abbildgn. im Text. 173 Seiten. 8°. 3⁰⁰.

WEHMER, DR. C. Beiträge zur Kenntniss einheimischer Pilze. Experimentelle Untersuchungen auf dem Gebiete der Physiologie, Biologie u. Morphologie pilzlicher Organismen. II. Theil. Mit 3 Tafeln u. 6 Tabellen. 184 Seiten. gr. 8°. Mk. 7⁹⁰.

GUSTAV E. STECHERT,

810 Broadway, New York.

Macmillan & Co.'s Recent Publications.

Essays in Taxation.

By EDWIN R. A. SELIGMAN, Professor of Political Economy and Finance, Columbia College. 8vo, cloth, pp. x, 434. Price, \$3.00 net.

The Law of Civilization and Decay.

An Essay on History. By BROOKS ADAMS. 8vo, cloth, \$2.50.

The Beginning of the Middle Ages.

By the Late R. W. CHURCH, M. A., D. C. L., Sometime Dean of St. Paul's, Rector of Whatley, Fellow of Oriel College. 12mo, cloth (Eversley Series), \$1.50.

Acton.—A Lecture on the Study of History.

Delivered at Cambridge, June 11, 1895. By LORD ACTON, LL. D., D. C. L., Regius Professor of Modern History. 12mo, cloth, 75 cents.

Herodotus.—The Fourth, Fifth and Sixth Books.

With Introduction, Notes, Appendices, Indices. Maps by REGINALD WALTER MACAN, M. A., Fellow and Tutor of University College, Oxford, and University Reader in Ancient History. Vol. I., *Introduction, Text with Notes.* Vol. II., *Appendices, Indices and Notes.* 2 vols., 8vo, cloth, \$7.50 net.

Browning Studies.

Being Select Papers by Members of the Browning Society. Edited with an introduction by EDWARD BERDOE, M. R. C. S., author of "The Browning Cyclopaedia," etc. 8vo, cloth, \$2.25.

Century Science Series.

Edited by SIR HENRY E. ROSCOE, D. C. L., F. R. S.

NEW VOLUME.

Lyell.—Charles Lyell and Modern Geology. By PROF. T. G. BONNEY, D. Sc., LL. D., F. R. S., etc. With Portrait. 12mo, cloth, \$1.25.

Tait.—Dynamics.

By P. G. TAIT, M. A., Sec. R. S. E., Honorary Fellow of St. Peter's College, Cambridge, Professor of Natural Philosophy in the University of Edinburgh. 12mo, cloth, \$2.50 net.

Menschutkin.—Analytical Chemistry.

By N. MENSCHUTKIN, Professor in the University of St. Petersburg. Translated from the Third German Edition, under the supervision of the author, by James Locke. 8vo, cloth, \$4.00 net.

Meyrick.—A Handbook of British Lepidoptera.

By EDWARD MEYRICK, B. A., F. Z. S., F. E. S., Assistant Master of Marlborough College. With Illustrations. 12mo, cloth, \$3.75.

MACMILLAN & CO., 66 Fifth Avenue, New York.

SCIENCE

EDITORIAL COMMITTEE: S. NEWCOMB, Mathematics; R. S. WOODWARD, Mechanics; E. C. PICKERING, Astronomy; T. C. MENDENHALL, Physics; R. H. THURSTON, Engineering; IRA REMSEN, Chemistry; J. LE CONTE, Geology; W. M. DAVIS, Physiography; O. C. MARSH, Paleontology; W. K. BROOKS, Invertebrate Zoology; C. HART MERRIAM, Vertebrate Zoology; S. H. SCUDDER, Entomology; N. L. BRITTON, Botany; HENRY F. OSBORN, General Biology; H. P. BOWDITCH, Physiology; J. S. BILLINGS, Hygiene; J. MCKEEN CATTELL, Psychology; DANIEL G. BRINTON, J. W. POWELL, Anthropology.

FRIDAY, DECEMBER 6, 1895.

CHARLES VALENTINE RILEY.

CONTENTS:

| | |
|---|-----|
| Charles Valentine Riley: A. S. PACKARD..... | 745 |
| Biographical Notes on Louis Pasteur: JULES MARCHOU..... | 751 |
| Unpublished Papers by Holbrook Cushman: Edited by W. HALLOCK..... | 757 |
| Measurements of the Accuracy of Recollection: J. MCKEEN CATTELL..... | 761 |
| Current Notes on Anthropology (XIV).— Latest Words in Craniology: Yucatecan Studies: D. G. BRINTON..... | 766 |
| Current Notes on Physiography (XX).— The Distribution of Plants and Animals; Plants of the Alpine Region: W. M. DAVIS..... | 767 |
| Scientific Notes and News:..... | 768 |
| Educational Notes and News..... | 770 |
| Correspondence:— Testimony versus Evidence: W. K. BROOKS..... | 771 |
| Scientific Literature:— Dana's Minerals and How to Study Them: S. L. PENFIELD. Darwin's Elements of Botany: L. H. BAILEY. Murray's Introduction to the Study of Seaweeds: W. A. SETCHELL. Culin's Korean Games: D. G. BRINTON..... | 773 |
| Scientific Journals:— The American Journal of Science; Psyche..... | 777 |
| Societies and Academies:— Biological Society of Washington: F. A. LUCAS. The New York Academy of Science: J. F. KEMP. American Chemical Society: DURRAND WOODMAN. Boston Society of Natural History: SAMUEL HENSHAW..... | 778 |
| New Books..... | 780 |

THE career of this distinguished naturalist, so suddenly closed while in good health, and with apparently many years of usefulness before him, was a remarkable one. Biologist, artist, editor and public official, the story of his struggles and successes, tinged as it is with romance, is one full of interest. Beginning life in America as a poor lad on an Illinois farm, he rose by his own exertions to distinction, and to become one of our most useful citizens in science, both pure and applied. His nature was a many-sided one, and his success in life was due to sheer will-power, unusual executive force, critical judgment, untiring industry, skill with pencil and pen, and a laudable ambition, united with an intense love of nature and of science for its own sake. This rare combination of varied qualities, of which he made the most, rendered him during the thirty years of his active life widely known as a public official, as a scientific investigator, while of economic entomologists he was *facile princeps*.

Charles Valentine Riley was born at Chelsea, London, September 18, 1843. His boyhood was spent at Walton-on-Thames, where he made the acquaintance of the late W. C. Hewitson, author of a work on butterflies, which undoubtedly developed his love for insects. At the age of 11 he went to school for three years at Dieppe, afterwards studying at Bonn-on-the-Rhine. At

MSS. intended for publication and books, etc., intended for review should be sent to the responsible editor, Prof. J. McKeen Cattell, Garrison on Hudson, N. Y.

Subscriptions and advertisements should be sent to SCIENCE, 41 N. Queen St., Lancaster, Pa., or 41 East 49th St., New York.

both schools he carried off the first prizes for drawing, making finished sketches of butterflies, thus showing his early bent for natural history, and his teacher at Bonn urged him to study art at Paris. But it is said that family circumstances, though rather, perhaps, a restless disposition, led him to abandon the old country, and at the age of 17 he had emigrated to Illinois, and settled on a farm about fifty miles from Chicago. When about 21 he removed to Chicago, where he became a reporter and editor of the entomological department of the *Prairie Farmer*.

Near the close of the war, in 1864, he enlisted as a private in the 134th Illinois regiment, serving for six months, when he returned to his editorial office.

He also enjoyed for several years the close friendship of B. D. Walsh, one of our most thorough and philosophic entomologists, with whom he edited the *American Entomologist*. His industry and versatility as well as his zeal as an entomologist made him widely known and popular, and gave him such prestige that it resulted in his appointment in 1868 as State Entomologist of Missouri. From that time until 1877, when he left St. Louis to live in Washington, he issued a series of nine annual reports on injurious insects, which showed remarkable powers of observation both of structure and habits, great skill in drawing and especially ingenious and thoroughly practical devices and means of destroying the pests. The reports were models and will never become stale. Darwin wrote in 1871: "There is a vast number of facts and generalizations of value to me, and I am struck with admiration at your power of observation. The discussion on mimetic insects seems to me particularly good and original." In reviewing the ninth and last of these reports, published in 1876, the *Entomologists' Monthly Magazine* of London, remarked: "The author, in giving full scope to his keen powers of observation,

minuteness of detail, and the skill with which he uses his pencil, and at the same time in showing a regard for that scientific accuracy—unfortunately too often neglected in works on economic natural history—maintains his right to be termed the foremost economic entomologist of the day." It goes without saying that this prestige existed to the end of his life, his practical applications of remedies and inventions of apparatus giving him a world-wide reputation. In token of his suggestion of reviving the vines injured by the *Phylloxera* by the importation of the American stock, he received a gold medal from the French government, and he afterwards received the cross of the *Légion d'Honneur* in connection with the exhibit of the U. S. Department of Agriculture at the Paris Exposition of 1880.

The widespread ravages of the Rocky Mountain locust from 1873 to 1877 had occasioned such immense losses in several States and Territories that national aid was invoked to avert the evil. The late Dr. F. V. Hayden, then in charge of the U. S. Geographical and Geological Survey of the Territories, with his characteristic energy and sagacity, initiated researches on the locust in the Territories. He sent Dr. P. R. Uhler to Colorado in the summer of 1875, and also attached the present writer to the Survey, who spent over two months in entomological work in the same year in Colorado, Wyoming and Utah, publishing the results in Hayden's Ninth Report. Mr. Walsh had made important suggestions as to the birthplace and migrations of the insect. Meanwhile Riley had since 1874 made very detailed studies on the migration and breeding habits and means of destruction of this locust (published in his Missouri State Report for 1876 and 1877). Dr. Cyrus Thomas had also been attached to Hayden's Survey, and published a monograph on the locust family, *Acrydidae*. As the result of this combined work Congress cre-

ated the United States Entomological Commission, attaching it to Dr. Hayden's Survey, and the Secretary of the Interior appointed Charles V. Riley, A. S. Packard and Cyrus Thomas members of the Commission. Dr. Riley was appointed Chief, and it was mainly owing to his executive ability, business sagacity, experience in official life, together with his scientific knowledge and practical inventive turn of mind in devising remedies, or selecting those invented by others, that the work of the Commission was so popular and successful during the five years of its existence. Meanwhile in 1878 while the report of the Commission was being printed, Riley accepted the position of Entomologist to the U. S. Department of Agriculture, and during the season of 1879 and 1880 he investigated the cotton insects, but owing to the lack of harmony in the Department, he resigned, Prof. J. H. Comstock being appointed, and ably filling the position. Congress meanwhile transferred the cotton-worm investigation to the Entomological Commission. Riley was reappointed to the position of U. S. Entomologist in June, 1881. His successor, Mr. L. O. Howard, has stated how efficient, broad and thorough was his administration of this office: "The present efficient organization of the Division of Entomology was his own original conception, and he is responsible for its plan down to the smallest detail. It is unquestionably the foremost organization of its kind at present in existence." Again he writes: "Professor Riley's work in the organization of the Division of Entomology has unquestionably advanced the entire Department of which it is a part, for it is generally conceded that this division has led in most matters where efficiency, discipline and system were needed. Its plan and discipline have been cited by one of the heads of the Department as worthy of imitation by all, and your own honored Westwood,

in expressing, in 1883, his admiration of Riley's work, said: 'I am sure it must have had a great share in inducing the activity in entomological work in America, which is putting to the blush the entomologists of Europe.'"

Indeed, so efficient, methodical and painstaking was Riley in whatever he undertook to do that had he been promoted to the position of Commissioner of Agriculture he would have been head and shoulders above any incumbent of that office, and, it is safe to say, would have administered its affairs with practical results far more valuable than those attained by any other Commissioner, as such an office should have been entrusted to a person who had had a scientific education, and not given as a reward for political service. As it is, he was the leader, says Mr. Howard, in many important innovations in the work of the Department. His division published the first bulletin, and in 'Insect Life' began the system of periodical bulletins, which has since been adopted for the other divisions of the Agricultural Department. He also took a large share in founding the Division of Economic Ornithology, Silk Culture and Vegetable Pathology, the first two being placed for some time under his charge. In an address, says Howard, before the National Agricultural Congress, delivered in 1879, in which he outlined the ideal Department of Agriculture, Professor Riley foreshadowed many important reforms which have since become accomplished facts, and suggested the important legislation, since brought about, of the establishment of State Experiment Stations under the General Government.

His practical, inventive genius was exhibited in his various means of exterminating locusts, in the use of kerosene oil emulsified with milk or soap, and in his invention and perfection—in which he was essentially aided by the late Dr. W. S. Barnard, who had special charge of the sub-

ject of mechanical appliances and remedies while connected with the Entomological Commission and the Agricultural Department, and whose 'assistance was fertile from the first,' as stated by Riley in his report—of the 'cyclone' or 'eddy-chamber' or Riley system of nozzles, which, in one form or another, are now in general use in the spraying of insecticide or fungicide liquids.

Although the idea of introducing foreign insect parasites or carnivorous enemies of our imported pests had been suggested by others, Riley, with the resources of his division at hand, accomplished more than any one else in making it a success. We will let Mr. Howard tell the story of his success, with the efficient aid of Mr. Albert Koebele, in introducing the Australian lady-bird to fight the fluted scale:

"One other trait which we have not mentioned is his *persistence in overcoming obstacles*. Nothing daunts him, and the more difficult an end is to attain, so much the more energy and perseverance does he put in its pursuit. A recent instance of this quality we may cite: The fluted scale (*Icerya purchasi* Maskill) has done immense injury to citrus fruit in southern California of late years. Ascertaining that it is kept in check by natural enemies in its native home, Australia, Dr. Riley foresaw the importance of endeavoring to introduce these enemies. Not only did Congress refuse to appropriate money for the purpose, but it refused to do away with a clause in the Appropriation Bill restricting all expenditures to the United States. In this state of affairs most men would have given up the fight; but Dr. Riley, after great trouble, succeeded in accomplishing his end by inducing the Secretary of State to allow the sending of two assistants on the Melbourne Exposition Commission, and through their labors the desired result was reached. Hundreds of specimens of an Australian lady-bird (*Vedalia cardinalis*) were introduced into California, and the dreaded pest is now being speedily reduced to absolute harmlessness. Professor W. A. Henry, of Wisconsin, in a recently-published article, says of this matter, in speaking of the enthusiasm of the people of California over the results of this importation: 'Without doubt it the best stroke ever made by the Agricultural Department at Washington.'"

It might be thought that all this admin-

istrative work of the office and in the field would have left little time for pure science or for much general reading or deep thinking. Let us see what he actually did accomplish in pure science. Riley's scientific writings will always stand, and show as honest work, thorough-going methods, care and accuracy as his office work, and they alone, aside from his practical work, were enough to give him an international reputation. In some of his studies he was probably essentially indebted to his assistants for specimens and aid in rearing them; in others he evidently depended on his own unaided observations and his skill in drawing. He was not 'a species man' or systematist as such; on the contrary his most important work was on the transformations and habits of insects, such as those of the Lepidoptera, locusts and their parasites, his Missouri reports being packed with facts new to science. His studies on the chronology of all the broods known of the 17-year cicada, and its *tredecim* or 13-year race, carried on through a long succession of years, will prove of lasting value, having intimate bearings on evolution problems.

His work on the larval characters and hypermetamorphoses of the blister beetles, *Epicauta*, *Macrobasis* and *Hornia*, besides Henous, was thoroughly good and beautifully illustrated by his own pencil. He brings forward in this paper a mass of new facts regarding the triangulin, or first larval stage of these beetles, and those succeeding, which he designates as the Carabidoid, the Scarabæidoid stage, the Coarctate or quiescent larva, these stages preceding the pupa stage. The value of these facts as set forth by so trustworthy and keen an observer, and corroborating and greatly extending those worked out by European observers, is apparent when we consider that the triangulin larva is perhaps the nearest approach to the Campodea-like ancestor of the winged insects, that the Meloidæ are consequently

among the most primitive and generalized of Coleoptera, and that from work based on such studies as these of the life-history of this and allied groups there has already resulted the germs of a truer phylogeny or classification of the entire order of Coleoptera. Of similar import are Riley's papers on the larval habits of bee-flies, on the luminous larviform females of the Phengodini and on the first larval stage of the pea-weevil (*Bruchus*). His studies on the systematic relations of *Platypsyllus* as determined by the larva evince his patience, accuracy and keenness in observation and his philosophic breadth.

For over twenty years he made observations on the fertilization of *Yucca* by those remarkable tineoid moths, *Pronuba* and *Prodoxus*, and from time to time published papers and notices of progress in his work which culminated in his paper entitled 'The *Yucca* Moth and *Yucca* Pollination' (1891-'92), a memoir remarkable for the patient, unremitting work carried on during his spare hours, its thoroughness in dealing with structural details, its critical accuracy, and for its faithful and artistic drawings. It is a paper of interest to botanists as well as zoölogists, and of value to the student of evolution. One of his last papers was a continuation and résumé of this subject entitled 'Some Interrelations of Plants and Insects' (1892).

Riley's contributions to the history and structure of the Phylloxera, of the scale insects, of the hop-plant louse, the Pemphiginae, Psyllidæ, etc., are of permanent interest and value. His best anatomical and morphological work is displayed in his study on the mode of pupation of butterflies, the research being a difficult one, and especially related to the origin of the cremaster, and of the vestigial structures, sexual and others, of the end of the pupa. Whatever he did in entomology was original. He may occasionally have received

and adopted hints and suggestions from his assistants, but he laid out the plan of work, supervised every detail, followed up the subject from one year to another, and made the whole his own. His originality in a quite different direction from biology is seen in his paper entitled 'Perfectionnement du Graphophone,' read before the French Academy of Sciences at Paris, in 1889. He was also much interested in Aëronautics, and took much delight in attending séances of spiritualists and exposing their frauds, in one case, at least, where another biologist of world-wide fame, then visiting in Washington, was completely deluded.

Riley was from the first a pronounced evolutionist. His philosophic breadth and his thoughtful nature and grasp of the higher truths of biology is well brought out in his address on 'The Causes of Variation in Organic Forms,' as Vice-President, before the biological section of the American Association for the Advancement of Science in 1888. He was a moderate Darwinian, and leaned, like other American naturalists, rather to Neo-Lamarckism. He says: "I have always had a feeling, and it grows on me with increasing experience that the weak features of Darwinism and, hence, of natural selection, are his insistence (1) on the necessity of slight modification; (2) on the length of time required for the accumulation of modifications, and (3) on the absolute utility of the modified structure." Riley from his extended experience as a biologist was led to ascribe much influence to the agency of external conditions, remarking, in his address: "Indeed, no one can well study organic life, especially in its lower manifestations, without being impressed with the great power of the environment." He thus contrasts Darwinism and Lamarckism: "Darwinism assumes essential ignorance of the causes of variation and is based on the inherent tendency thereto in the offspring.

Lamarckism, on the contrary, recognizes in use and disuse, desire and the physical environment, immediate causes of variation affecting the individual and transmitted to the offspring in which it may be intensified again both by inheritance and further individual modification."

The following extracts will illustrate his clear and vigorous style of thought and expression and his attitude on the relations between science and religious philosophy. Regarding the question of design he says: "Both Lyell and Gray believe in the form of variation having been planned or designed. It seems to me that the evidences of design in nature are so overwhelming that its advocates have an immense advantage over those who would discard it. A fortuitous cosmos is, to most persons, utterly inconceivable, yet there is no other alternative than a designed cosmos. To accomplish anything by a process, or by an instrument, argues greater, not less power, than to do it directly, and even if we knew to-day all the causes of variation, and understood more thoroughly than we do the method of evolution, we should only carry the sequence of causes a step further back and get no nearer to the Infinite or Original Cause."

"Evolution teaches that nothing is yet so perfect but it may be improved; that good comes of the struggle with evil and the one can never be dissociated from the other. The erect position which has given man his intellectual preëminence has brought him manifold bodily ills. No evolutionary sibyl looks to a millennium. Higher development must ever mean struggle. Evolution shows that man is governed by the same laws as other animals." "Evolution reveals a past which disarms doubt and leaves the future open with promise—unceasing purpose—progress from lower to higher. It promises higher and higher intellectual and ethical attainment, both for the individual

and the race. It shows the power of God in what is universal, not in the specific, in the laws of nature, not in departure from them."

"The experience gained by those who have reached the highest ethical and intellectual growth must be formulated in precept and principle to be of any benefit to society at large, and the higher ethical sentiment and religious belief—faith, love, hope, charity—are priceless beyond all that exact science can give it."

Riley, an excellent head of a bureau, but sometimes uncomfortable and too independent as a subordinate, at times got into hot water with his superiors in the Department. He was sensitive to criticism, and was somewhat prone to controversy, usually, however, winning in such encounters. Until one came to know him more intimately he was liable to be misunderstood, and by his occasional bluntness made some enemies, but as years rolled on these passing antagonisms melted away.

Vigorous in mind and body, though of late years suffering from overwork, fond of out-door sports, he was a fearless rider on horseback, and an adept with the bicycle, on which, alas, he rode to his death.

His hospitable house at Sunbury was beautified by rare flowers, shrubs and trees, of which he was passionately fond. He was domestic in his tastes, and left a wife and five children to mourn his loss.

Riley left an indelible mark on his time, and the historians of natural science and of agriculture in America will scarcely ignore the results of thirty years of earnest work in pure and applied entomological science.

His scientific honors were well deserved. He was a member of many societies at home and of the entomological societies of France, Berlin, Switzerland and Belgium. He was elected in 1889 an Honorary Fellow of the Entomological Society of Lon-

don, and was also Honorary Fellow of the Royal Agricultural Society of Great Britain. He was for two years President of the Academy of Science of St. Louis, being the youngest member so honored. He was founder, and for two terms President, of the Entomological Society of Washington, one of the founders of the Biological Society of that city, and an honorary member of the horticultural societies of Illinois, Iowa, Kansas and Missouri. The Kansas State Agricultural College gave him the degree of A. M., and the Missouri State University in 1873 conferred upon him the degree of Ph. D. He was lecturer on entomology at Cornell University and at other institutions.

A. S. PACKARD.

BROWN UNIVERSITY.

BIOGRAPHICAL NOTES ON LOUIS PASTEUR.

A DISTINGUISHED chemist, Dean of the Bussey Institution, Harvard University, Francis H. Storer, said a few days before the death of Pasteur, "Pasteur is the greatest genius produced in this century," and, he added, "He is a chemist."

As it has been my good fortune to be intimate with Pasteur since our college days, living in the same room, as *chum*, during several years, and keeping up our intimacy, notwithstanding my wandering life in both hemispheres, a few words of remembrance may be acceptable. I have before me at this moment a bundle of his letters, the first one dated 10 June, 1845, and the last dated 14 December, 1887, with letters after that date from his wife to keep me 'au courant' of his failing health; all his memoirs and papers, bound in 7 volumes, each one with a dedication in his handwriting, such as, 'A mon ami Jules Marcou, souvenir affectueux, L. Pasteur;' and three portraits, taken in 1863, 1868 and 1891, all with dedication, as, "A mon ancien et bon camarade Jules Marcou, souvenir affectueux, L. Pasteur." So I am pretty well able to

give exact information on his life and character.

Born at Dole, Jura, 27 December, 1822, in the 'rue des Tanneurs, 43,' (Tanners street), where a marble table was erected the 19th of July, 1883, with the inscription 'Ici est né Louis Pasteur, le 27 Décembre, 1822;' Pasteur was removed a few weeks later to a small tannery on 'La Vache' creek, between the village of Marnoz and the Chateau de St. Michel, near Salins, Jura, and remained there until the fall of 1829; when his father finally took a tannery on 'La Cuisance' creek, at the western outlet of the little town of Arbois, Jura, where Pasteur was educated and kept his home until his death. The family originally came from Salins, Jura, where during the eighteenth century they were well known as tanners. His father was born there, and his mother, *née* Roqui, at the village of Marnoz, Canton of Salins. Jean Joseph Pasteur, born in 1790, did not receive a classical education; he took the profession of his family, and was a journeyman tanner at Salins, when the conscription took him in 1811, and sent him as a private in a regiment of infantry, in Spain. There by his bravery, good conduct and capacity, he was rapidly raised to the rank of sergeant-major, and decorated Knight of the Legion of Honor, not an easy position to reach in the French armies scattered all over Spain, far from Napoleon and consequently much neglected as regard promotion and decoration of the Legion of Honor. Dismissed from military service in 1815, Pasteur returned to Salins, and resumed his work as a tanner. He was a good looking and very intelligent man. If he had received an education he would have made his mark. Knowing how important education was, he did all in his power to do to give his son an opportunity. First, Louis Pasteur became a pupil at the small college of Arbois, from 1831 to 1839, then he was sent as an 'interne' to the

College Royal of Besançon, where he stayed from 1839 until 1842. There he took in 1840 the title of Master of Arts, or 'Bachelier,' and prepared for the 'Ecole normale Supérieure.' Then he did not show any aptitude for chemistry; it is true that the old professor of chemistry and physics was a old fashioned savant, extremely diffuse in his lectures, and Pasteur was not attracted by the lessons; so much so, that it was I, who have but little capacity for the work, who was chosen as the assistant by the professor. There was no pay, and the professor chose for his assistant the pupil that he liked best, provided he was an 'interne,' in order to have him within reach one or two hours before his lecture to prepare the experiments and the instruments. Then Pasteur was not what is called a brilliant student, but he was a good one, standing second in our class, myself being No. 3. As a great privilege, the provisor of the college gave to Pasteur and me one room, where we worked and slept, instead of being obliged to be with the other pupils in the 'Salle d'Etudes,' and in a great dormitory. Our room was only whitewashed, and our furniture most elementary. What Pasteur did, at once, was to make a good fresco picture, on the side of the wall above the blackboard. That picture, well executed considering the time and the youth of the painter, represented a scene of Childe Harold of Byron. Pasteur had a remarkable disposition for artistic work, and we all thought then that he would become an artist; so much so that we called him, as a nickname, 'The Artist.' And the title stuck to him many years after his college life. I may add that he drew my portrait in colored pencil, at that time a good likeness, when I was eighteen years old. I possess it still, it is signed 'P.(asteur) L.(udovicus) del (delineavit), 1842.'

From 1843 to 1846 Pasteur was a pupil of the *Ecole Normale Supérieure*, following the

lectures of the Sorbonne, as is the custom. The third year he chose the 'Sciences physiques et chimiques,' and graduated an 'Agrégé' for those sciences in August, 1846. It was during his stay at the Normal School that Pasteur showed his taste for chemistry. He was in perfect rapture at the end of each lecture on chemistry by the two ordinary professors of that science then at la Sorbonne, Messrs. Balard and Jean Baptiste Dumas. To be sure Pasteur admired the talent of exposition of Dumas; but was a little shocked by his way of dressing too much like a scientific dandy, by his too studied posture and by his affectation. It was not so with Balard, who was entirely sympathetic to the modest tastes of Pasteur. But what attracted most of his attention was neither Balard nor Dumas, but their assistant, then a rather old man, M. Barruel. As a practical chemist, a skilful manipulator, Barruel had few equals, if any; all the operations always succeeded with such precision, exactness and at the right time that Pasteur was absolutely astounded and in perfect rapture. I have seen him, at the end of some of those lectures, with his eyes filled with tears, ready to cry; so much was he moved by what he had heard and seen.

At the end of 1846 Pasteur was appointed assistant to Professor Balard, who was 'Maître des conférences de chimie,' at the Normal School; a new post, poorly paid and rather difficult to obtain from the French government, which then was sparing in regard to new scientific expenditures. All that Pasteur wanted was to stay in Paris, no matter how poorly he was paid. At that time the Normal School was on the point of being removed from the old and inadequate building of the annex of the Louis-le-Grand College, to a large and even beautiful mansion built especially for that purpose in the rue d'Ulm. The school was not removed, however, until September,

1847; but the two laboratories for chemistry and physics were ready for occupancy in 1846, and Pasteur, who had charge of the Chemical one, began at once the installation, being with Bertin, the physicist, the two first inhabitants of the new Normal School mansion. For the time the laboratory was excellent, even luxurious, and from the first day, with the help of a young man named Thomas, who acted as servant, and has since become a very able professional chemist, Pasteur became that extraordinary manipulator, unequalled in the history of chemistry for exactness, sharp and delicate observations.

The first work of Pasteur is on crystallography and rotatory polarization; and to the surprise of Biot and Mitscherlich he created a new chapter of chemical crystallography, by his discovery in regard to the tartrate crystals. Then he worked on dimorphism. During the year and a half that Pasteur passed as chemical assistant at the Normal School incessant laboratory work took all his time; often he was at the laboratory at 6 a. m., and at 12 o'clock p. m. he was still studying, in his room, chemical books borrowed from the Library.

We used then to take our meals together; hardly speaking to one another at breakfast, so full we were, both of us, of our work. It was only at dinner time that we exchanged our thoughts; walking after dinner first to my room, rue d'Enfer, 51; Pasteur and I, would get up the four stories, and pass one or two hours talking on scientific subjects, travels, etc., often two or three other friends joined us, such as Quintino Sella, the mineralogist and Italian statesman; Bartholomeo Gastaldi, the geologist; A. Pomel, the paleontologist and geologist, and Oscar Fraas, the geologist. Then Pasteur always pursuing an idea, would take French leave and go to his room in the rue d'Ulm. We never went into society, or to

theatres, or to 'cafés;' taking now and then a walk, in the Luxembourg Garden; in fact our lives were hermit lives, entirely devoted to science and friendship.

It was during those two years, October, 1846, to March, 1848, that Pasteur learned to be such an expert in chemical laboratory work; and he owed a great deal to the private teaching of old Barruel, the chemical assistant at la Sorbonne. But he was also a rare and unique pupil, extremely skillful with his hands, with near-sighted eyes, which scrutinized everything, and let pass nothing without seeing what it was, extremely patient, never tired when at work, and with those great qualities not an absent minded man, always being on the contrary wide-awake.

In May, 1848, Pasteur, who had taken his degree of doctor of physical and chemical sciences at the end of 1846, was appointed professor of physics and chemistry at the lyceum of Dijon, where he stayed only three months, being called to the faculty of science at Strasburg, first as substitute, and three years later as full professor.

During the five years he passed at Strasburg, from October, 1848, to August, 1854, Pasteur studied the correlations between dissymetry and the deviation of polarized light in minerals. He proved that the molecular dissymetry is the only sharp demarcation existing between the chemistry of 'la nature morte' and the chemistry of 'la nature vivante.' It was during his stay at Strasburg that Pasteur married Miss Mary Anne Laurent, daughter of the rector of the academy at Strasburg. It is said that he was working so steadily at an experiment in his laboratory, the morning of his his wedding, that some friend was obliged to go there and bring him up to be prepared for the ceremony. Never was a better match and a more harmonious couple.

In October, 1854, Pasteur removed to Lille, where he had been appointed dean of

the new faculty of science just created then by the French government. As soon as installed in his new position he began the work which has given him his world wide reputation—his study of the ferments. He was then thirty-two years of age, and had never studied physiology, anatomy or biology, and notwithstanding the difficulties inherent to such a change in the direction of his researches, leaving the physical and chemical molecular works, he turned abruptly to physiology, against the advices of his friends and patrons, Biot and Dumas.

Pasteur began his studies on ferments with milk, finding there bacteria so small that their diameter was only the thousand part of a millimetre. Then he took the transformation from wine into vinegar; when suddenly he was confronted by a very sharp opposition brought up by Félix A. Pouchet, of Rouen, on the question of spontaneous generation. Pasteur saw at once that the origin of microbes was not to be eluded any longer, and without hesitation he began a series of observations requiring the greatest care, ability and keen attention which had perhaps ever been given before in laboratories. Every scientific friend of Pasteur tried to dissuade him from such researches, except one, the great crystallographer, M. de Senarmont, who had an absolute confidence in the extraordinary ability of Pasteur as an experimenter. The great success achieved by Pasteur has put now to rest forever the question of spontaneous generation, which broke the first ring in the chain of the 'Origin of Species' of Darwin. It is curious that neither Darwin nor any of his followers had ever tried to oppose Pasteur; not but that opponents in England made, like Pouchet, objections and presented observations which seemed to break Pasteur's experiments; but little by little all opponents left the field, and John Tyndall did not hesitate to accept and uphold Pasteur's views.

The studies on wine, which followed closely those on vinegar, required a great deal more research, and the volume published by Pasteur: 'Etudes sur le vin, ses maladies etc' in 1866, is and will remain the standard work. The amount of money saved by Pasteur's method of treating diseased wine may be counted by millions and millions of francs; for it is used not only in France but in every wine growing country.

The French government, justly desirous to put an end, if possible, to a sort of pest among the silkworms which destroyed almost all the fortunes of the southern part of France devoted to that industry, asked Pasteur to go there and study the sickness of the silkworms. Dumas, the chemist, told the Emperor Napoleon III., "if any body can do anything about it, it is Pasteur!" At first Pasteur was unwilling to abandon his work on ferments, which had already given such great result; and it was only to the pressing solicitation of Dumas, who was from a district of Languedoc, most affected and almost totally ruined by the pest on silkworms, that Pasteur yielded at last. On taking leave of me, he said: "I do not know, what I am going to find; it is *la bouteille à l'encre!*"

Pasteur worked steadily during five years at the silkworms, with the splendid result of finding a practical way to stop the pest; and now the silk industry of France, Italy and other European countries engaged in producing silk is more prosperous than it ever was before the epidemic.

In the two volumes: 'Etudes sur la maladie des Vers à Soie,' 1870, Pasteur has given to the world all his researches and remedies. It is in Vol. 1, p. 99, that we read the following prophetic sentence, of which his subsequent discoveries have given such a splendid confirmation: 'Il est au pouvoir des hommes,' says he, 'de faire disparaître de la surface du globe les

maladies parasitaires, si, comme c'est ma conviction, la doctrine des générations spontanées est une chimère.'

Pasteur remained only three years at Lille, and in October, 1857, he removed to Paris, as director of the Scientific Section of the Normal School, taking his residence again rue d'Ulm, nine years after leaving it in 1848. This time he was finally settled in Paris. He knew well that the excessive centralization of France obliged a savant to be in Paris, if he wanted not only to be appreciated, but also to get sufficient help from the government for his researches. At first he had no laboratory, being obliged to build one at his own expense in the garret of the Normal School. By and by a vast and good laboratory was built, exclusively for his own use, in the yard directly on the left after entering the gate of the school. A marble slab has been lately placed against it, recalling that it was the Pasteur Laboratory. It was there that most of his discoveries in bacteriology were made.

In October, 1868, Pasteur was struck by a very strong attack of hemiplegy; during several days he was in constant danger of losing his life, and for months he was so infirm as to be unable to leave his bed or his room. Little by little, however, he recovered—a wonderful case of recovery. Paralyzed on the left side, his arm and leg kept visible marks of the paralytic stroke, and he looked always as a wounded man; but happily his mind was never affected, after the immediate danger was past. I remember one night, when I kept watch over him, his eyes—always very beautiful—were almost lighted up by happiness. "You are surprised to see me so contented; it is because I begin to feel that I shall get out of this terrible sickness; my head is full of thoughts because I have so much to do with the ferments!" His desire of prolonging his life was mainly in order to continue his works

on bacteriology. What an infatigable worker! Being only forty-five years old, and having never abused anything but too hard work; Pasteur rallied, and was able to go again to Alais, in Languedoc to continue his observations on the silkworms. The next year he was in Italian Austria, at the villa Vicentina, near Trieste, carrying on his researches; when the news of the declaration of war between France and Prussia reached him. He started at once to come back, passing through southern Germany. What he saw in passing at Munich had made him anxious; and I remember a visit which he received at the beginning of August of General Favé, the commanding officer of the Polytechnic School. The general told him that the arms possessed by the French army were so much superior to those of the Germans that no fear was to be entertained as to the final result.

Pasteur received notice from Marechal Vaillant, a few days after his return, that the Emperor Napoleon was so satisfied with his work on the silkworms that he has just signed his nomination as a Senator. But the nomination was never printed in the *Journal Officiel*, and was left in the hurry of the departure on the desk of the Emperor; so Pasteur was only a Senator *in partibus*.

Pasteur was a very strong patriot; the defeat of the French armies went to his heart so strongly that he abandoned all work, and for the first time his laboratory was deserted. Having retired at his house at Arbois, he passed a most distressing winter, crying like a child at the reading of newspapers. When Franche-Comté was invaded he left Arbois to retire to Switzerland. Passing through Pontarlier he found there the retreating columns of Bourbaki's army in great confusion, and among them he met his only son, Jean Baptiste, a corporal of chasseurs.

As soon as he was able to recover his balance Pasteur went to Clermont-Ferrand,

in Auvergne, where his favorite pupil, M. Duclaux, was professor of chemistry, and there in his laboratory, during the Commune, Pasteur began his series of researches on the ferments of beer, which resulted in the publication, in 1876, of his magistral work, 'Etudes sur la Bière, ses maladies, etc.'

We have come now to the work, which has placed Pasteur at the head of the Philanthropists, as the greatest benefactor of humanity. First it was his discoveries of antiseptics, which, as Dr. Lister says in a letter to Pasteur, dated February, 1874, was suggested to him by the reading of his studies on the germs of putrefaction. It was not without hesitation that Pasteur became a physiologist, as he said often then, "I am neither a Doctor of Medicine nor a veterinary surgeon;" but good words to encourage him came from many masters of science, such as Claude Bernard, Rayer, Bouley, Paul Bert, Tyndall, Huxley, etc. In a letter dated February, 1876, Tyndall expresses his unbounded admiration for the researches of Pasteur, saying that "thanks to his works, medical sciences will soon get rid of empirical methods and be placed on true scientific bases."

The discovery of the bacteria of the anthrax conducted Pasteur to the sure cure of that terrible and disastrous sickness among sheep, oxen and horses, saving millions of francs to agriculturists and stock breeders; then came in succession the septicæmia, the cholera of chickens and hydrophobia. The last discovery is the one which made Pasteur so popular; persons bitten by mad dogs and mad wolves came from Russia, Germany, Austria-Hungary, England, Algeria, even America, to be inoculated and treated. At first Pasteur was very timid; and the first two of his patients, who died, notwithstanding his care, were very distressing to him; but medical colleagues encouraged him, saying

that some cases are refractory to all sorts of medications, and the brilliant results of numerous cures, shown by careful statistics, soon put an end to his hesitations.

The cure of diphtheria, although not made by Pasteur, was inspired by him, and Dr. Roux followed closely all the directions and suggestions made to him by his illustrious master and teacher.

Pasteur met many opponents, for it is in human nature to oppose discoveries made against accepted theories, and savants occupying exalted position do not like to be interfered with. In Germany Liebig and Koch, in England Dr. Bastien, and in France Berthelot and Pouchet, made opposition not exempt from passion and jealousy. The attack of Berthelot, who published, six months after the death of Claude Bernard, a posthumous paper found in notes, rather incomplete and confused even, which if true was the inauguration of a new system of spontaneous generation among the ferments of grape wine, took Pasteur by surprise and was very painful to him, for he has always professed a great admiration for Claude Bernard, with whom he was in most intimate friendship. Without losing time, Pasteur started for Arbois and carried out delicate experiment, in one of his own vineyards, which after one year showed most conclusively the mistake of both Bernard and Berthelot. This discussion is printed in full, in 'Examen critique d'un écrit posthume de Claude Bernard sur la fermentation,' 1879.

Pasteur received more honor during his life than any other savants ever did, and he entered into immortality before his death. The honors bestowed on him were all well deserved; for not only did he orient a new medical science, surgery, the veterinary arts, the making of beer, wine and vinegar, but he always declined to take patents of any sort, notwithstanding most tempting offers of large sums of money

from speculators, saying that he was paid by the French government and that all his discoveries belonged to the public. As Huxley says: "The discoveries of Pasteur are sufficient alone, to have repaid all the tribute of war of five milliards of francs paid by France to Germany."

In our time, when money seems to be everything, and when we have the discouraging spectacle of competitions to get at great fortunes by all means, it is a great example to see a man refusing to be tempted and perfectly satisfied with a modest pension of 12,000 francs yearly, soon raised to 25,000 francs during his life, to be continued to his widow and afterwards equally divided between his two children. To be sure the honor is unique. His public funeral, also at the national expense, attended by the President of the French Republic, and followed by the mass of the population, without regard to parties, is another noble manifestation, unmixed with any discordant notes, from the humblest citizen, and even children, to his highest surviving contemporaries.

One more word, Pasteur's last creation was his Institut, rue Dutot, built by private subscriptions and sustained by rents from a yet too small capital, increased happily yearly by annual appropriations from the French budget. There the new roads he opened to science will continue to attract the attention of the scientific world, and discoveries will go on under his direction and methods. Pasteur was very anxious to place it on a sure and somewhat independent basis, and in the last letter he wrote me with his own hand, when already stricken with the ailment which terminated his life, he says:

"INSTITUT PASTEUR,

PARIS, le 14 décembre, 1887.

MON CHER MARCOU:

Je suis heureux des bonnes nouvelles que tu me donnes de ta santé. La mienne

a été éprouvée dans ces derniers temps par une congestion qui m'a rendu la parole un peu difficile. Quoiqu'il en soit je suis, depuis quelques semaines, une hygiène de repos et de calme qui me réussit assez bien.

Tout va bien au laboratoire et l'Institut Pasteur, est presque terminé, moins l'aménagement intérieur. L'inauguration cependant n'aura lieu qu'à la fin de l'été prochain et nous n'en prendrons possession qu'en Novembre, 1888. Ce sera grand et confortable et de bel aspect. La souscription a dépassé deux millions. Avec le legs récent de Madame Boucicaut (du *Bon Marché*) et un autre legs d'un négociant de Lyon, elle dépassera deux millions deux cent mille francs. Les constructions et l'achat du terrain atteindront douze cent mille francs et plus.

Nous avons donc besoin d'accroître encore beaucoup notre capital. J'ai confiance en de nouveaux legs.

Ah! si nous étions en Amérique, le pays aux généreuses et grandes initiatives!

Déjà nous rendons mille actions de grâces à la très digne Madame Boucicaut qui n'a pas contribué à la souscription pour moins de deux cent cinquante mille francs.

Je m'arrête. Ecrire me fatigue encore par l'obligation de courber la tête.

Tous les affectueux souvenirs de Mme Pasteur et de moi, à Mme Marcou et à Monsieur Philippe, à toi mille bonnes amitiés.

L. PASTEUR."

JULES MARCOU.

CAMBRIDGE, MASS, 14th November, 1895.

HOLBROOK CUSHMAN.

HOLBROOK CUSHMAN was born in New York City, in 1857, and was there prepared for college, entering Columbia in 1874. He was graduated with honors in 1878, receiving the 'Fellowship in Science.' From Columbia he went to the University at Würzburg, Bavaria, studying physics with Kohlrausch, mathematics with Prym and

Selling, and chemistry with Wislicenus. After three years work at Würzburg he went for a year to Helmholtz at Berlin. After his return to America in 1882, and until 1890, he was chiefly occupied with commercial applications, having been for several years with a large firm manufacturing electrical supplies in England, and subsequently he was connected with a similar firm in this country. In 1890 he was appointed assistant in physics at Columbia, and quickly rose to the rank of instructor, which he held at his death, on October 25, 1895.

As a man and a friend he was all that the words in their best sense imply.

If one were to judge Mr. Cushman's services to science by his published work, one would obtain a most incomplete idea of their extent. Although deeply interested in the more theoretical questions which have specially occupied physicists in the past score of years, and always willing to discuss them, still his heart was chiefly set upon the practical applications, not in a commercial sense, but referring to teaching or research. Many pieces of very useful apparatus and many excellent laboratory methods are the results of his activity in this field. His chief service to science, and the one which will remain as a lasting monument to the strongest side of his activity, is the admirable organization of the laboratory teaching of physics at Columbia. To his untiring industry and thorough devotion is due a system which handles 400 students annually in a limited space, giving to each a course adapted to his individual needs. For each of the experiments, some 200 in number, he has prepared full explanations and instructions for making the determination. It is proposed to issue this collection with some little additional material as a laboratory manual for the use of our students. It is also proposed to contribute to SCIENCE several

papers on methods and apparatus prepared by him and left unpublished at his death.

Collimating Magnetometer and Local Variometer.

Unpublished paper by HOLBROOK CUSHMAN.

Edited by W. HALLOCK.

MAGNETOMETER.

IN laboratory determinations of the intensity of the Earth's magnetic field it is often desirable to be able to obtain the deflection observations with an accuracy greater than is possible with the usual glass pointer over a 15 or 20 cm. divided circle and yet not incur the expense and elaborateness of the telescope and scale, or the lamp and scale.

The method devised is intermediate in accuracy between the two methods above mentioned and gives the readings in tangents of the angle directly.

A in the accompanying Fig. 1 is the magnetometer with a plain mirror about 2 cm. in diameter with a vertical black line across the center of its face, B & B' are the scales upon which the deflecting magnet M is placed, S is a scale, a common meter stick will do, mounted perpendicular to B at a distance of one meter from the magnetometer needle at A. Upon the scale slides the sight, P, shown $\frac{1}{2}$ natural size in Fig. 3. It consist of a piece of sheet brass about 0.5 mm. thick, slit and bent so that two side strips, n n, slide upon one side of the scale and the middle one, o, upon the other side, toward the magnetometer; h is a hole about 1 mm. diameter, and the side toward the mirror is covered with white paper upon which is a cross X. By a series of simple sightings the magnetometer A is oriented in line with the scales B and B', and upon their common zero. Placing the sight upon the point of the scale S directly over the axial line of B, A and B', the whole apparatus is to be so oriented

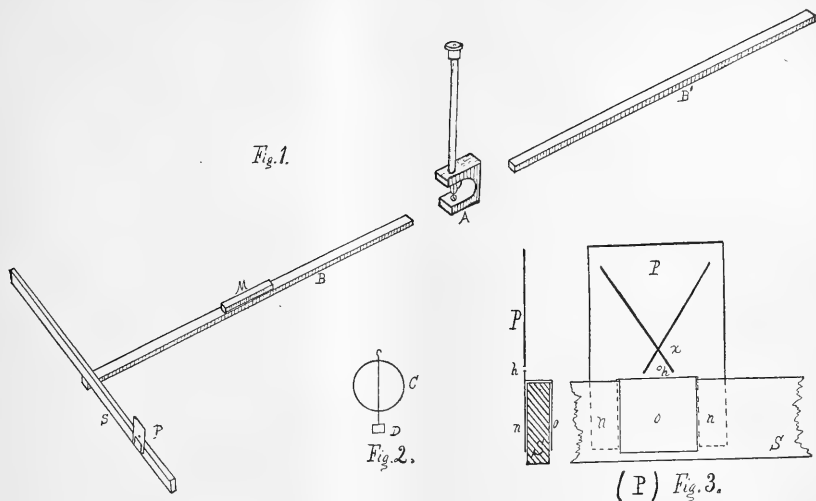

that on looking through the hole *h*, the cross *X* is seen reflected in the mirror of *A* with its intersection upon the vertical line. The magnets are upon the back of the mirror shown $\frac{1}{2}$ natural size at Fig. 2. *D* is a wing dipping into an oil cup and acting as a damper. Of course, this method of sighting brings the hole *h* and cross *X* into the plane normal to the mirror. The magnet *M* being placed in position, the mirror is deflected and the sight *P* is slid along the scale *S* until the cross is again seen coincident with the line upon the mirror. The difference between this and the previous setting of the slide expressed as a decimal of a meter will be the natural tangent of the angle of deflection, and is easily correct to the third, with a fair approximation to the fourth place of decimals. *P* being always set on the normal to the mirror and its position measured upon the tangent to a circle whose radius is one, the reading is always the natural tangent of the angle. This method of reading angles will be found convenient in many other cases.

VARIOMETER.

The method of reading angles above described has been applied to an apparatus for measuring the local variations in the horizontal component of the Earth's magnetism with an error somewhat less than 1%.

Fig. 4 shows the apparatus about one-third natural size. It consists of a magnetometer *M*, similar to that shown in Fig. 1, so mounted as to be movable on a slide *A*. *B* is a coil of copper wire of about 5 ohms resistance whose support is also movable upon a scale parallel to *A*, so that *M* is upon the axis of *B*. Two Daniel cells at *C* and *C'* (*C'* is removed in the cut) send a constant current through the commutator *D* and the coil *B*. The sight *P* is similar to that shown in Fig. 3. The scale *S* is divided to read horizontal intensity directly. That is with zero at the center, distances *d* either way upon the scale are computed according to the formula, $d = \frac{KC}{H}$. *H* is the horizontal component of the earth's magnetism, *C* the cur-

rent in the coil and K its factor. KC can be found empirically by assuming values for d and H , which will be convenient and leave the magnetometer at a suitable distance from the scale S . Of course if it is preferred one can use a millimeter scale and read the tangents and reduce each time. The operation with the apparatus is as follows:

the horizontal intensity found for the fiducial locality. The coil B is then slid backward or forward until the mirror normal falls upon the cross of the sight. Everything is then left in position and the variometer taken to the second station; the sight being adjusted normal to the new deflection of the mirror, the reading will be the intensity at that place. Thus the in-

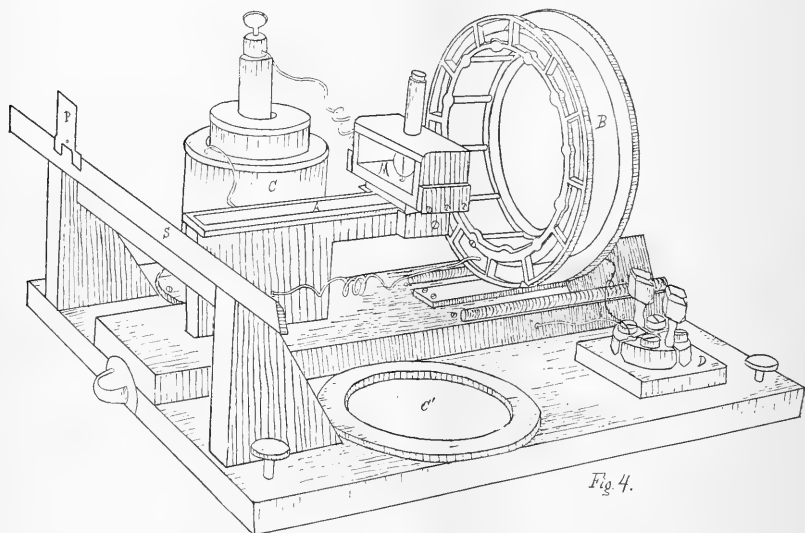

Fig. 4.

Before the current in B is started, the sight is put at zero and the instrument oriented at the standard locality as described for Fig. 1. This oriented position should be so marked that the variometer can be easily and quickly returned to it. Similarly the oriented positions at the various stations should be established before commencing the observations.

The current is started and allowed to flow till fairly constant. When observations are to be made, the sight is placed at the point upon the scale reading the same as

instrument gives the horizontal component directly. Naturally one must always take the precaution to commutate the current, and take frequent check readings at the fiducial location.

In this way observations about a room or building can be conveniently made and results obtained whose errors are certainly not greater than the daily and other fluctuations of intensity. Naturally by increasing the distance from the mirror to the scale and the precautions for constancy of current, one can obtain more accurate re-

sults, but would correspondingly lose in compactness and portability. The apparatus as illustrated has been used in the physical laboratory at Columbia and has proved itself very simple and useful.*

COLUMBIA COLLEGE, November 18, 1895.

*MEASUREMENTS OF THE ACCURACY OF
RECOLLECTION.*

WE know that ordinary observation and recollection are not altogether reliable. We do not credit all the stories that we hear, even though we may not doubt the good faith of the narrators; we see that conflicting evidence is offered in courts of justice when no perjury is intended; we regard as partly mythical records supposed for many centuries to describe historical events. But we do not know how likely it is that a piece of testimony is true, nor how the degree of probability varies under different conditions. If we could learn this by experiment the result would be a contribution to psychology, and would at the same time have certain important practical applications.

*The above drawing of the local variometer was made by a method which may prove useful to others, and which, so far as I know, is new. It is often desirable to get a perspective line drawing of a rather complicated piece of apparatus without employing a skilled artist, or consuming too much time. To produce the above cut a small photographic negative of the variometer was taken, from which a contact positive was made. The positive was placed in a projection lantern and thrown upon a screen consisting of a piece of drawing paper upon a board, the size of the image being two or three times as large as the cut. The outlines were then traced in with pencil, and one can also shade directly where desired. This sketch was drawn over with india ink and made ready for the photolithographer. The advantage of this method over drawing upon a silver print, which is afterward 'dismissed' is that the drawing and tracing is done upon a larger picture than the final cut, and hence a coarser style may be employed and yet the desired fineness attained in the final reduced cut. Of course a projection lantern of some sort is desirable, but a very simple one will do. The conventional shading in the variometer was put in after the tracing was finished.

W. HALLOCK.

I have tried in various ways to secure a quantitative determination of the reliability of recollection and evidence, and will here report on the answers to some questions asked the junior class in psychology in Columbia College in March, 1893. The questions were answered in all or in part by the fifty-six students present.

Several simple questions were first asked and the students allowed in each case one-half minute to consider and write the answer. They were also requested to assign the confidence which they felt in the correctness of their answer—*a* if quite certain, *b* if tolerably certain, *c* if doubtful, *d* if the answer were a guess.

The first question was 'what was the weather a week ago to-day?' The answers were pretty equally distributed over all kinds of weather which are possible at the beginning of March. Of the 56 answers, 16 may be classed as 'clear,' 12 'rain,' 7 'snow,' 9 'stormy,' 6 cloudy and 6 partly stormy and partly clear.* It seems that an average man with a moderate time for reflection cannot state much better what the weather was a week ago than what it will be a week hence. Yet this is a question that might naturally be asked in a court of justice. An unscrupulous attorney can discredit the statements of a truthful witness by cunningly selected questions. The jury, or at least the judge, should know how far errors in recollection are normal and how they vary under different conditions.

When asked 'what was the weather two weeks ago?' 20 students answered 'clear,' and 18 'stormy.' The confidence in this case was slight, only two being sure that their answers were correct and 8 having some confidence, while the others were doubtful or did not answer at all.

We ought not, indeed, to conclude from these conflicting answers that no inference as

*On the day in question it snowed in the morning and cleared in the late afternoon.

to the weather on those days can be drawn. Almost nothing could be inferred from any single answer, but the answers taken together give information of a degree of exactness which may be defined. We can, however, better consider this matter in connection with questions requiring a quantitative answer.

Three questions were asked with a view to learning the ordinary accuracy of observation: "Do chestnut trees or oak trees lose their leaves the earlier in the Autumn?" "Do horses in the field stand with head or tail to the wind?" "In what direction do the seeds of an apple point?" The questions were all answered correctly more often than incorrectly, but only by a moderate majority. Thus 30 students thought that chestnut trees lose their leaves the earlier in the Autumn, and 21 were of the opposite opinion; 34 students thought that horses in the field stand with tails to the wind, and 19 thought they stand facing it. Thus in only about three cases out of five will a college student answer such a question correctly.

Each class of persons would of course have a different index of precision. In the present cases country boys would probably do better, whereas in other directions, as in judging of character, they might not do so well. This opens up an interesting direction for research. Is the ordinary observation of men or women better? of students in classical or scientific courses? etc.

The degree of confidence may be noticed. The students were sure their answers were correct in all 34 times, and in these cases they were in fact correct 27 times. They were somewhat or quite doubtful in all 70 times, and in these cases were correct 37 times, scarcely more than a majority. Their judgment of their own accuracy was therefore of some value, and the degree of confidence can with advantage be taken in

ordinary testimony. But there is great individual difference in this respect. Some observers are nearly always sure that they are right, whereas others whose decision is equally or more likely to be correct are much less confident. In other and more elaborate experiments I have found that when an observer is entirely doubtful, for example as to which of two weights is the heavier, and makes a guess, his guess is more likely to be right than wrong. This opens an opportunity for determining the part played by subconscious inference in the decisions of daily life, as in judging the the character from the face.

As regards the direction in which the seeds in an apple point, 24 answers were 'upward,' or 'toward stem;' 18 'toward center;' 13 'downward,' and 3 'outward.' The reader may be left to decide whether or not he knows in what direction the seeds in fact point, and what information he can obtain from these answers.

Two questions were asked, the answers to which measure the ordinary accuracy of information: "Was Luther or Michel Angelo born the earlier and by how many years?" "In what year did Victor Hugo die?" Michel Angelo was assigned the earlier year in 29 of the 45 answers. The average of the answers placed his birth 12 years before that of Luther, which is nearly the correct value (8 years). The average departure from the correct value was 54 years, which measures a considerable degree of ignorance.

The average assigned the death of Victor Hugo 12 years too early, with an average departure from the true date of 13 years. The median would here give a more correct date, as the average is unduly influenced by a few who assigned a very early date. The extreme values, indeed, betray great ignorance. One student thought Hugo died in 1790, another that he is still alive. One student thought that

Michel Angelo was born 300 years earlier than Luther.

Three questions were asked intended to determine the average accuracy in estimating weight, distance and time. These were the weight of the text-book (James' *Briefer Course in Psychology*) used by the class, the distance between two buildings on the college grounds and the time usually taken by students to walk from the entrance door of the building to the door of the lecture room. The results are shown in the accompanying table, there being given the approximate actual magnitude, the average estimate with the constant error, the average departure of the estimates from the average estimate and from the actual magnitude and the median.

| Estimation of | Actual Magnitude. | Average Estimate. | Constant Error. | Average Residual. | Average Error. | Median Estimate. |
|---------------|-------------------|-------------------|-----------------|-------------------|----------------|------------------|
| Ounces, | 24 | 17 | - 7 | 5 | 5 | 16 |
| Feet, | 310 | 356 | + 46 | 179 | 162 | 250 |
| Seconds, | 35 | 66 | + 31 | 36 | 40 | 60 |

It thus appears that in these cases there was a marked tendency to under-estimate weight and to over-estimate time. Length was over-estimated, but to a less degree. For the magnitudes used the average vari-

ation was about one-third of the weight and one-half of the distance or time. The actual errors were larger in the case of weight and time, but not in the case of distance. The middle estimate or median value is in all cases smaller than the average. The degree of confidence of the observer does not in these cases seem to measure objective accuracy.

Curves are subjoined showing the distribution of the estimates. The residuals are divided into classes of the size of one-half the theoretical probable errors, and the ordinates represent the percentages of the whole number of observations falling within each class.

The curves approach the bell-shape required by the theory of probabilities, but not very closely. The departures are partly due to the limited number of observations (56 in each case), and the tendency to estimate in round numbers; in estimating time $\frac{2}{3}$ of the estimates were $\frac{1}{2}$, 1 or 2 minutes. But there is a large constant error, and in addition there is an excess of large positive errors which makes the average in all cases larger than the median. This tendency obtains in nearly all variations and measurements and has not received the attention it deserves. The aver-

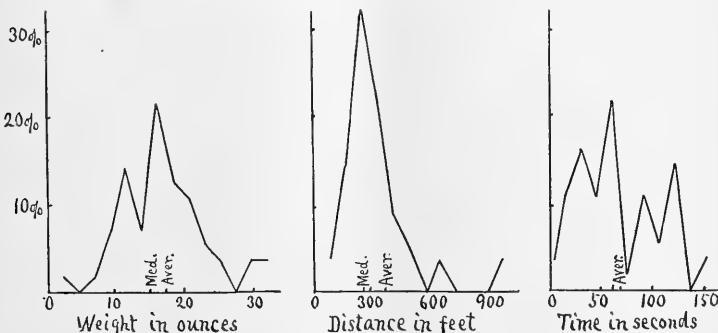

Fig 1. The distribution of errors in estimating weight, distance and time.

age weight of men may be 150 pounds, and there are men weighing 300 pounds, but none weighing 0. In actual measurements it is probable that large positive errors occur more frequently than negative errors of the same size.

When students were asked what was said during the first two minutes of the lecture in the same course given one week before, the accounts were such that the lecturer might prefer not to have them recorded. From the testimony of the students it would appear that two minutes sufficed to cover a large range of psychological

times, but the average estimate of 4,022 had an average variation of 2,669 times. It might be supposed that the number of times was in any case sufficient to impress a tolerably exact recollection of the hall, but the drawings vary to such an extent that any one taken at random would be likely to give an entirely false impression. An examination of the many drawings, however, leaves on the mind a fairly exact idea of the hall, and it would be possible to make a composite drawing which would be found to approach a correct ground plan. Three of the ground plans (supposed to be

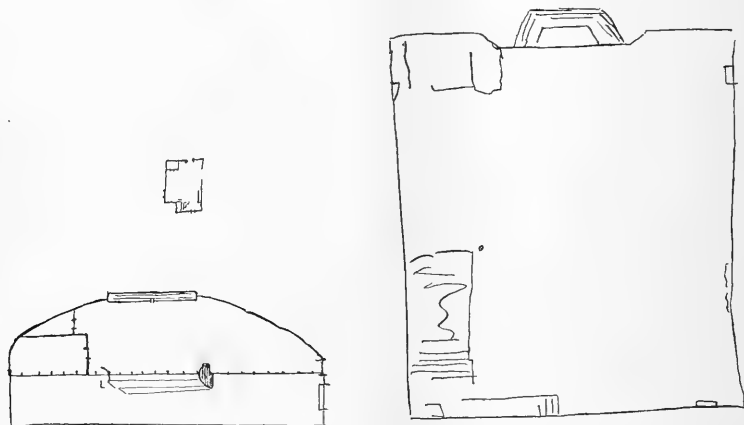

Fig. 2. Ground-plans of a hall drawn from memory (scale 1:96).

and other subjects, and to make many statements of an extraordinary character.

The last task set was to draw in a scale of about $\frac{1}{4}$ inch to the foot a ground plan of the entrance hall of the building in which the class met, ten minutes being allowed. The students were also asked to state about how many times they had passed through the hall. All the students (with some possible exceptions) had passed through the hall about an equal number of

drawn on the same scale and here reduced about one-half) are subjoined. This is worth the while if only to emphasize the worthlessness of many hundred casual observations as compared with one measurement.

Psychology is continually gaining ground as a natural and even as an exact science, and some progress is made when in any direction the surmise of daily life is superseded by systematized facts and measurements.

It is sometimes said that the useful applications of the material sciences have no parallel in the case of the mental sciences, but I venture to maintain that psychological experiments may have a high degree of practical value. Thus, determinations such as those here described are useful in various ways.

It would be of value to an individual and to those having dealings with him if he could be assigned a definite index of precision. This could be determined early in life, and the effects of environment and methods of education could be determined. It is generally acknowledged that children should be treated as individuals and not as bits of stone to be shaken together until they became marbles, equally round. We consequently need to study methods which will discover individual differences early in the life of the child. Education may properly be devoted to overcoming defects which would interfere with usefulness, but perhaps its more important function is to strengthen qualities which the individual possesses and which may be developed so as to serve his welfare and that of society. From the point of view of science, private benevolence and State aid should be directed less to supplying the cripples with crutches than to supplying the agile with ladders. For this purpose it is evidently important to devise tests which will demonstrate natural aptitudes while the child is very young.

It is especially desirable to devise some objective method to test the fitness of candidates for the civil service. Examinations are of great importance in merely securing some method of appointment other than reward for personal or political services rendered. But the form of examination has often only an artificial connection with the duties of the official. The story is told that in answer to the question "what is the distance of the moon from the earth?"

the candidate replied that he did not know, but that it was not so near that it would interfere with his work in the post office. It is, indeed, a fact that the man who had independently observed (contrary to the testimony of novelists) that the crescent moon does not rise in the evening, or (contrary to the testimony of poets) that a baby does not reach for the moon, would discover mental qualities of greater importance for most work than the man who remembered the number of miles from the earth to the moon. Of course the accuracy of observation would only be one of a number of tests which could be applied. The candidate for post office clerk whose eyesight is good; who can accurately judge of the weight of a letter; who can make many similar movements in succession without becoming fatigued; whose range of perception is large so that he can perceive at a glance the address on an envelope; whose reaction-time is short, so that he can quickly distribute the letters, etc., would probably be a more efficient public servant than one who passed a slightly better examination in grammar and arithmetic. Stress should be laid on the advantages of obtaining quantitative results. In this case the candidates can be arranged in order without any chance of prejudice or mistake on the part of the examiner. The report would show that A has passed a better examination than B, and that the chances are (say) nine to one that this result is correct.

As a last example of the usefulness of measurements of the accuracy of observation and memory I may refer to its application in courts of justice. The probable accuracy of a witness could be measured and his testimony weighted accordingly. A numerical correction could be introduced for lapse of time, average lack of truthfulness, average effect of personal interest, etc. The testimony could be collected in-

dependently,* and given to experts who could affirm for example that the chances are 19 to 1 that the homicide was committed by the defendant, and 4 to 1 that it was premeditated.

A proper application of measurement and the theory of probabilities to the affairs of daily life would add greatly to intellectual detachment and clearness of view. It would be salutary to have in mind the probable error of the newspaper one is reading. The historian could assign the probable accuracy of each event which he narrates, in the same manner as the physicist assigns a probable error to his measurements. We should know what reliance we can place on the stories we hear, and on our own memory of past events. When the relative probabilities of the various conflicting claims of business, politics and religion are expressed in simple numerical formulas, a great part of the wasted energy of life may be directed to useful ends. It is a long way to travel, but we should advance when and how we can. J. McKEEN CATTELL.

COLUMBIA COLLEGE.

CURRENT NOTES ON ANTHROPOLOGY (XIV.).

LATEST WORDS IN CRANIOLOGY.

IN the 'Monitore Zoologico Italiano,' for May last, Dr. L. Moschen presents an able sketch of the recent conflicts of opinion in craniology, and declares in favor of what he calls 'the natural method.' This is that of Prof. Sergi, already explained in this journal. Moschen shows that the method of Kollmann leads to erroneous results, and that at present no unanimity prevails as to the ethnic significance of skull forms. In this he is unfortunately most correct.

*The independently formed verdict of three jurors, if concordant, would probably have more validity than the unanimous verdict of twelve jurors in consultation. Questions of such great practical importance as this could be definitely settled by the proper psychological experiments.

Prof. Dr. Busch, of Berlin, has a carefully prepared article in the 'Verhandlungen der Deutschen Odontologischen Gesellschaft' (Bd. VII., Heft. 1), on the cranial forms in different races of men. The paper is marked by close observation and sound judgment. His conclusion is that "the cranial differences of races do not lie in particular measures, nor in the relation of the indices, but in the coincidence of certain peculiarities of the head and face which can scarcely be expressed numerically, but can be shown by accurate pictorial presentations of the different aspects of the skull." This is not far from 'the natural method.'

YUCATECAN STUDIES.

THE almost simultaneous appearance of four works, all of exceptional merit, on the archæology of Yucatan cannot fail to excite a wide interest in that country.

First may be named the fifth part of Mr. A. P. Maudslay's contributions to the 'Biologia Centrali-Americana' (London, July, 1895). It is devoted to Chichén Itzá, and contains 24 pages of text and an atlas of 25 plates. The first of these is a very carefully prepared map of Yucatan and Tabasco. Then follow views of the monuments of the site, analyses of the architectural details, and faithful copies of the inscriptions. The singular round tower, called El Caracol, is the subject of especial attention.

Next comes Mr. H. C. Mercer's 'Hill Caves of Yucatan' (Phila., Lippincott & Co.). This gives the results of very painstaking excavations in the caverns of the Sierra de Yucatan. Striking illustrations and an attractive literary style add to the high scientific value of the volume. The author's conclusions may be briefly summed up by the statement that nowhere did he discover traces of an occupation of the soil anterior to the Mayas, or of a civilization

less advanced than that we know they enjoyed at the Conquest.

Briefer is the report of Mr. Theobert Maler of his many years explorations of the ruined cities of the peninsula. It is published, with numerous photographic reproductions, in the *Globus* for October. Some of the ruins he visited have been previously unknown, and present architectural details of a higher order than any yet described.

Finally, though by no means of least importance, is an essay by Prof. W. H. Holmes, of the Columbian Museum, Chicago. It is the result of personal studies of various ruined cities last winter, and I may speak of it from a sight of the proofs. The author portrays with consummate skill the development of Mayan architecture, and solves many problems with reference to it which have hitherto remained obscure.

D. G. BRINTON.

UNIVERSITY OF PENNSYLVANIA.

CURRENT NOTES ON PHYSIOGRAPHY (XX.).
THE DISTRIBUTION OF PLANTS AND ANIMALS.

THE manner in which the distribution of plants and animals should be treated in the study of physical geography is a vexed question. The preference of the writer would be to leave the actual distribution of species to botany and zoölogy, and to introduce in geographical study only such examples of distribution as shall illuminate the control exercised over plant and animal life by the forms of land and water and by the physical conditions of climate; or such other examples as shall illustrate the interdependence of plants, animals and man, in the savage state of local supply or in the civilized state of extended exchange. Classifications of plants and animals, such as appear in certain text-books on physical geography, are quite out of place; even faunal and flora areas are not, as such, proper geographical subjects, but belong in zoölogy

and botany. In a word, when a plant or animal, or the area of its occurrence, is the object of study, the discipline is biological; when the forms of land or water, or the conditions of climate which control the growth or distribution of a plant or animal is the object of study, the discipline is geographical. The great variety and number of plants and animals encouraged to grow in the luxurious belt of the equatorial rains, or the sparsity of individuals and the specialized forms and colors of plants and animals that struggle to survive in the trade wind deserts, are examples of geographical themes; the particular characteristics of these various plants and animals, and their systematic relationship to the inhabitants of other regions, are examples of biological themes.

PLANTS OF THE ALPINE REGION.

THE peculiar forms assumed by plants of the Alpine region, offering excellent material for truly geographical study as defined in the preceding note, are described entertainingly by G. Bonnier (*Les plantes de la région alpine, et leurs rapports avec le climat*. Ann. de géogr., Paris, iv. 1895, 393-413). The plants are dwarfed, the stalks are low, the leaves are close to the ground in rosettes or tufts, the roots are large in proportion to the stalks and leaves; new individuals are often propagated from runners, so that the ripening of seeds need not be depended on. Growth begins before the snow of winter entirely disappears, and during the short summer advance is made rapidly to maturity; different phases of growth being abbreviated and their succession accelerated. While accounts of these peculiar features are used to intensify the appreciation of the average temperature of the Alpine region, of the long-continued presence of its snow cover and of the brevity of its open summer, they properly belong under geography; but when they are followed

by experiments on plants of the same species grown at high and low levels, and on minute observations of modifications of structure at high levels, the subject assumes a decidedly botanical flavor. Botanists as well as geographers will therefore find interesting matter in Bonnier's account of his gardens in the Alps and the Pyrenees, where for some years past he has cultivated plants taken from lower lands. The figures illustrating the difference between plants grown from two parts of a single rootstock, one in the Alps, the other in the lowlands, are particularly instructive from the remarkable modifications of the normal form produced by the Alpine habitat.

W. M. DAVIS.

HARVARD UNIVERSITY.

SCIENTIFIC NOTES AND NEWS.

WE are extremely glad to state that the report of the death of Dr. George M. Dawson, quoted in the last issue of this journal from the *London Standard*, was false. It was due to confusing the cable dispatch announcing the death of Dr. George Lawson. *Nature* states, in its issue of November 21st, "after a part of last week's issue of *Nature* had been printed off, containing a note announcing the death of Dr. George Dawson, we were rejoiced to be able to stop the press and cancel it, as a cablegram contradicted the rumor." We also should have been able to contradict the accounts contained in the English papers, had we not been compelled to go to press one day earlier than usual owing to the Thanksgiving holiday.

THE administrative council of the Pasteur Institute, at a recent meeting, presided over by M. Bertrand, permanent secretary of the Académie des Sciences, decided to appoint a subscription committee, with a view to the erection of an international monument to perpetuate the memory of Louis Pasteur.

THE first meeting of the General Committee of the Huxley Memorial was called for Wednesday, November 27th, in the Museum of Practical Geology, Jermyn Street, his Grace the Duke of Devonshire, Lord President of the

Council, in the chair. Resolutions with respect to the form of the memorial were to be submitted to the meeting.

A MEETING of the Council of the Royal Society on December 12th will be devoted to the discussion of the question of Antarctic research. The discussion will be opened by Dr. John Murray, who will be followed by other specialists, each dealing with his own particular branch of science. It is expected that the Council will endorse the report of the Society's Antarctic Committee, urging the necessity for the resumption of Antarctic exploration by means of an adequately equipped Government expedition. It is stated that a well equipped German expedition to the Antarctic continent is now being prepared.

SIR JOSEPH LISTER has been nominated by the retiring president and council for election as president of the Royal Society. The election will take place at the anniversary meeting on November 30th. Prof. Michael Foster has been nominated for reelection as one of the secretaries.

CALVERT VAUX, the landscape architect, was drowned on November 20th. He was born in London about 71 years ago and came to America at the age of twenty-four to become the partner of A. J. Downing. He planned many of the most important parks in America, and New York City is especially indebted to him for the design of Central Park and for his long and able service in the Department of Parks.

THE health committee of the Glasgow Town Council has decided to establish and equip a complete bacteriological department in the sanitary buildings now in course of erection. The laboratory is to be in charge of an expert in bacteriology.

A. M. VILLON died on November 4th, of typhoid fever, at the age of twenty-eight. He was the author of 'Dictionnaire de chimie industrielle' (in course of publication at the time of his death) and other works and editor of 'La revue de chimie industrielle.'

M. DE BERNADIÈRES reported to the Paris Academy of Sciences on November 11th that with the coöperation of the ministers of the marine seven expeditions had been sent out with a view

to the preparation of a magnetic map of the earth. The expedition to Iceland has already accomplished its task in a satisfactory manner, and it is hoped that a map superior to any similar publication may be issued before 1900.

The next International Medical Congress has been postponed for one year and will be held in Moscow in 1897.

The paper by Prof. George M. Comstock on 'A Course in Astronomy for Engineering Students,' published recently in this journal (Vol. II, p. 502), was read before the Springfield meeting of the Society for the Promotion of Engineering Education.

AMONG the papers announced to be read at an extra meeting of the Royal Society on November 28th were 'Mathematical contributions to the theory of evolution; III. Regression, heredity and panmixia,' by Prof. Carl Pearson, and 'Examination of gases from certain mineral waters,' by A. Kellas and Prof. Ramsay.

An editorial article in the *Lancet* for November 23rd calls attention to the desirability of testing the hearing as well as the eyesight of school children. Weil found 35 per cent. of the pupils in the schools in Stuttgart, and Moure 17 per cent. of those at Bordeaux, more or less deaf in one or both ears. The degree of deafness is very easily determined by requiring the child to repeat words uttered at a measured distance in a quiet room, and unilateral deafness by closing one or other ear with the finger. Words spoken in a conversational tone should be recognized by those whose hearing is normal at a distance of 15 to 20 meters. In many cases deafness and related disorders may be cured by medical or surgical treatment, and in any case it is important that the deafness of a child should not be mistaken for stupidity.

DR. THOMAS DWIGHT'S recent notes on the Dissection and Brain of the Chimpanzee 'Gumbo' in the *Memoirs of the Boston Soc. Nat. Hist.* contains numerous references to other papers showing how large is the amount of individual variation in this species. Although several species of chimpanzee and gorilla have been described it will be interesting to see how they will stand the test of time and more material. Unfortunately specimens of the large an-

thropoids are seldom accompanied by full and sufficient data and not improbably most, if not all, of the species will prove to be subspecies. The large apes seem subject to a large amount of variation. Not only does the orang of Sumatra differ from that of Borneo, though not specifically, but the Bornean orangs differ among themselves in size and color so that they have been divided into three species, mainly on points due to age or sex. Evidently there is much work to be done before the exact status of the large anthropoids can be considered as definitely settled.

At a meeting of the Engineering Association of the South in Nashville, Tenn., November 13, the retiring president, Prof. Wm. L. Dudley, of Vanderbilt University, delivered an address on 'The Development of Technical Education in the United States.' The following are the officers for the year 1895-96:

Hunter McDonald, President.
W. G. Kirkpatrick, First Vice-President.
J. J. Ormsbee, Second Vice-President.
Lucius P. Brown, Secretary.
W. M. Leftwich, Treasurer.
Wm. L. Dudley, E. C. Lewis, H. D. Ruhm, Jno. B. Atkinson, Directors.

IN the November number of *The Nineteenth Century* Mr. Herbert Spencer again criticises Lord Salisbury's president's address before the British Association in 1894. Lord Salisbury's address has perhaps received more attention than its scientific importance warrants, but Great Britain is fortunate in having a Premier who is competent to preside over its Association for the Advancement of Science and whose address deserves scientific criticism.

LEOPOLD VOSS has issued a new edition of Kroll's *Stereoskopische Bilder*, to which new pictures have been added by Dr. R. Perlia. The series consists of twenty-six pairs of colored pictures which may be united by the stereoscope. In some of the slides the principal figure is the same for both eyes while the details are different, and in others two different pictures are to be united, as for example a bird and a cage. The pictures are recommended as useful in exercising the muscles of the eyes of children suffering from strabismus, and in any case make a

useful scientific toy. They are sold at the moderate price of seventy-five cents.

Nature states that an International Marine and Fisheries Exhibit will be held at Kiel next year, in connection with a provincial exhibition in Schleswig-Holstein, and will be opened from May 13th to the end of September.

JOHANNES ADOLF OVERBECK, for forty-two years professor of archaeology at the University of Leipzig, died recently, aged sixty-nine years.

M. POINCARÉ reported to the Paris Academy on November 11th that he had found that the moon influences the production and direction of cyclones.

MR. W. R. BROOKS, director of Smith Observatory, Geneva, N. Y., discovered on the morning of November 21st a comet in the southeastern sky. The position was right ascension $9^{\text{h}} 51^{\text{m}} 50^{\text{s}}$, and declination S. $17^{\circ} 40'$. The comet has a northerly motion.

WE have received part I. of Vol. V. of the proceedings of the California Academy of Sciences, issued on November 18th. The proceedings contain 27 papers, extending to 784 pages and including 75 plates. The work of the Academy is of great interest and importance, more especially as most of the papers are concerned with the fauna, flora and physiography of California. Among the papers are a Review of the Herpetology of Lower California, by John van Denburgh; California Water Birds, by Leverett M. Loomis; The Neocene Stratigraphy of the Santa Cruz Mountains of California, by George H. Ashley; The Fishes of Sinaloa, by David Starr Jordan; Contributions to Western Botany, by Marcus E. Jones, and Explorations in the Cape Region of Baja California, by Gustav Eisen.

DR. JULIUS VON SCHRODER, professor of chemistry at the School of Forestry at Tharandt died on October 27th, at the age of 52. The deaths are also announced of Edward Combes, a well-known Australian engineer; of Lieutenant Otto E. Ehler, the German explorer, who was drowned while making his expedition across British New Guinea; of Oscar Borchert, the African traveler, who died of malarial fever at the Bethlehem Institute, near Ludwigslust,

and of George Edward Dobson, a writer on natural history, who died on November 26, at the age of 51.

MR. F. O. T. DELMAR, of Bayswater, who died on October 14th, has left £100,000 to his trustees to form a fund to be called the Delmar Charitable Trust. Nine-tenths of the annual income from this fund is to be divided between selected charitable institutions in London or its neighborhood, 'having regard to the relative importance and magnitude of each institution.' The testator expresses his desire to benefit in particular the establishments for the care and treatment of epileptic and cancerous patients and the Royal Society for the Prevention of Cruelty to Animals.

UNIVERSITY AND EDUCATIONAL NEWS.

THE Medical Department of Vanderbilt University was reorganized last spring. A new faculty was elected and a graded course of three years was adopted. The faculty consists of ten professors and twenty instructors, lecturers and assistants. Dr. Wm. L. Dudley is dean of the faculty and Dr. Richard Douglas secretary. Dr. W. M. L. Coplín, late of Jefferson Medical College, Philadelphia, fills the chair of pathology and bacteriology. The department has removed this session into the Medical College building lately erected and furnished at a cost of \$70,000.

THE Chemical Laboratory of the Rose Polytechnic Institute was burned on the morning of November 9th. The walls of the Laboratory and a part of the floor were saved, but the rest of the building and the entire equipment were destroyed. The loss was about \$7,500, of which \$5,000 was covered by insurance. The chemical lecture room is in another building, and provisions has already been made for students of the chemical course to continue their laboratory work. A new equipment has been ordered and the building will be rebuilt as soon as possible.

THE ninth annual convention of the Association of Colleges and Preparatory Schools of the Middle States and Maryland was held at Lafayette College, Easton, Pa., under the presidency

of Prof. N. M. Butler, of Columbia College, on November 29th and 30th.

THE Brown University Lecture Association has announced the following courses of free public lectures for the coming season: 'The Religions of China,' by Rev. F. Huberty James, formerly of China; 'Lectures on the History of Song,' by Louis C. Elson, of the *Boston Daily Advertiser*; 'Studies in Social Economics,' by Hon. Carrol D. Wright, Esq., of Washington; 'The Divina Commedia, its Predecessors and Successors,' by Prof. Courtney Langdon, of Brown University. Prof. Charles S. Hastings, Ph.D., of Yale University, will give three lectures upon a subject in physical science to be announced later.

THE calendar of the Imperial University of Japan for 1894-95 shows that it ranks among the great universities of the world. All the schools are represented; there are laboratories, hospitals and museums, an astronomical observatory, a seismological observatory, botanic gardens, a marine biological station, etc. The number of students is as follows:

| | |
|-----------------------------|------|
| University Hall..... | 94 |
| College of Law..... | 432 |
| College of Medicine..... | 175 |
| College of Engineering..... | 229 |
| College of Literature..... | 179 |
| College of Science..... | 98 |
| College of Agriculture..... | 261 |
| Total..... | 1468 |

There are fourteen full professors in the college of science, and a majority of those registered in University Hall are engaged in scientific research. A large part of the work accomplished is published in the *Journal of the College of Science*, which maintains a high scientific standard.

DR. STRAHL, of Marburg, has been appointed to the chair of anatomy in the University of Giessen, in succession to Professor Bonnet, and Dr. Charles B. Ball has been appointed regius professor of surgery in the place of the late Sir George Porter in Dublin University.

On November 1st a laboratory for study and research was opened in connection with the school of physical and industrial chemistry at 42

Rue Lhormond, Paris. By paying a fixed sum monthly to the city anyone desiring to work in this laboratory will have all its facilities at his disposal.

CORRESPONDENCE.

TESTIMONY VERSUS EVIDENCE.

"It is, we are told, the special peculiarity of the devil that he was a liar from the beginning. If we set out in life with pretending to know that which we do not know; with professing to accept for proof evidence which we are well aware is inadequate * * * we are assuredly doing our best to deserve the same character."—Huxley. *Essays V.*, 54.

Some weeks ago (*SCIENCE*, Oct. 4, 1895, p. 435) I quoted from recent numbers of the journal extracts to the effect that the phenomena of vitality are not 'explicable' in terms of physical matter and mechanical energy, and that some of them, those of consciousness and volition, are 'agencies' and causes of structure.

Since many thoughtful students believe that the facts warrant nothing more than a humble confession of ignorance of these matters, I called upon the learned bodies which have endorsed the utterances which I quoted to publish the evidence that proves them; and I ventured the prediction that the publication of this evidence would render the said learned bodies memorable for all time.

So far as I am informed this proof has not yet been published; but a number of correspondents have used the pages of *SCIENCE* to discuss my article, which contained the following passage (p. 439): "What can fundamental disagreement among those who speak with authority lead to except disaster? Are we not bound to find first principles which will command the assent of all thinking men?"

Since this correspondence furnishes new evidence of the imperative need for this agreement regarding the foundations of biology I venture to discuss it.

I some time ago (*SCIENCE*, April 5, 1895, p. 384) expressed my conviction that it is better to be called a vitalist or any other hard name by zealous monists than to be convicted of teaching as proven what we know is not proved; and, so far as I am personally concerned, the only answer I care to give these correspondents is that it is better to be called a 'materialist' or a

'dogmatist' by pious vitalists than to pretend to know what we do not know.

One of these correspondents says (Oct. 18th, p. 521-2) that the opinions I had quoted are a 'scaffolding' which the builder will not confound with his more permanent edifice; and, furthermore, that I fail to discriminate between volition and consciousness, and am no psychologist.

As I plead guilty to this latter charge I gladly take this opportunity to ask the 'Psychologist' a few questions, although I fear lest, in my ignorance, I may be like the patient who endows his wise old family doctor with more power than he really possesses.

Will the 'Psychologist' tell me, in the first place, how any one who does not use the words in a Pickwickian sense can affirm that "when the protozoa seek oxygen they have to be aware that they need it, and must have some knowledge of the fact when they get it," without believing that the said protozoa are both conscious and endowed with volition?

I am greatly surprised to find in the same communication (p. 522) the statement that "every naturalist knows that consciousness is a property of protoplasm."

If I were to disclaim any knowledge of this sort I should, no doubt, be told I am no naturalist, but I think no one will make this reply to Huxley, who tells us "We may all have our opinions as to whether mental phenomena have a substratum distinct from that which is assumed to underlie material phenomena or not, though if any one thinks he has demonstrative evidence * * * all I can say is, his notion of demonstrative evidence differs from mine."

I have myself been somewhat disturbed in mind by the thought that, while we are bound to find just principles which will command the assent of all thinking men, no less than three mutually exclusive opinions on this matter are current among naturalists. Is it possible that the correspondent holds that these three are one; or is the statement that 'every naturalist knows' so and so only a 'scaffolding,' to be torn down when the writer sees fit?

Without dwelling on this point I wish to ask the 'Psychologist' how, if consciousness is a

'property,' a 'conscious state' can be an 'agency.' Can the writer mean that it is the 'state' and not the consciousness which is the 'agency,' or how does the 'Psychologist' interpret these hard sayings?

The writer seems to me to be undertaking a difficult feat, which I shall watch with some excitement—the attempt to ride at the same time the most rampant steeds of both materialists and vitalists.

This correspondent attempts to emend my request for evidence that consciousness and volition can cause structure or anything else, by substituting for the words 'anything else' a specific case (p. 522). I therefore ask the 'Psychologist' whether this concrete statement of the problem of volition makes it any easier to solve.

My modest request for evidence that consciousness and volition can cause anything is more roughly handled by another correspondent (P. 554), who attributes to me, in quotation marks, the assertion that 'consciousness and volition cannot cause structure or anything else.'

This correspondent fills two pages of SCIENCE with an accusation of dogmatism, which would be no more than my just due if I had ever made the statement which he so skillfully constructs out of my words.

We are told that it is a maxim for practice in certain circles to ignore all your opponent says, and to answer what he does not say; but this style of reasoning is no ornament to the pages of a scientific journal, least of all one which had already printed and might have verified the statement which is misquoted.

In the article to which these correspondents refer I insisted that the test of truth is evidence and not conceivability; and I illustrated, by the inversion of the retinal image, the fact that evidence may furnish conclusive proof of truths which are inconceivable.

The question whether this illustration is well chosen or ill chosen has, of course, no bearing upon the accuracy of the general statement, and it seems to me that attention has been directed from the main issue by the comments which have been made upon the illustration, al-

though I cannot admit that this was an unhappy selection.

To the correspondent who asks me (p.287) why I cannot conceive that the image on my retina is upside down, I can give no answer except that I am made so, although I admit that I have no right to speak for others, and that I should not have used the editorial *we* in the statement referred to.

I find many of the truths of science inconceivable, and while my intellect apprehends the logic of the evidence that the sun is more than a million times as big as the earth, I am absolutely unable to conceive this stupendous fact, or to reconcile it with my experience.

It seems to me that my conceptions of nature are pretty strictly regulated by my perceptions; and, while I have no desire to measure the minds of others by my own limited powers, I must ask the 'Psychologist' whether this correspondent has not failed to discriminate between apprehension of the evidence for a fact, and conception of the fact itself.

While I suppose every one admits that knowledge of the chemistry and physics of the organism is a necessary condition for progress in biology, I hope Professor Gage will improve every fitting occasion to tell the 'mechanical physiologists' that the problems of life are not yet reduced to physics and chemistry, and that consciousness is not yet proved to be 'a property of protoplasm.'

I shall gladly second him to the best of my ability as often as he insists that no progress in our knowledge of vital actions can be hoped for unless the organic machine is studied as a living being; but I must point out the fact that none of the passages he quotes (p. 590) have any bearing whatever on the problem of the origin of vital phenomena except so far as they show that it is as yet unsolved. This is a very different matter from proof that the problem is insoluble; and a schoolboy who believes that what his teacher has not yet explained is 'not explicable' may be making a most grievous blunder.

We are all of us schoolboys in knowledge of nature, and our admission of ignorance is not dogmatism but caution. I, for one, do not dare to say any natural event is 'not explicable'

by means of the data of physical science; although I am sure all who have studied with me will confirm my statement that I have neglected no opportunity to insist that we have not yet made the slightest approximation to such an explanation of the phenomena of life.

I am, however, equally confident that I know of no approximation to any other explanation; nor do I believe that any one has any moral right to believe in one unless he is prepared to give evidence for it.

W. K. BROOKS.

BALTIMORE, November 19, 1895.

SCIENTIFIC LITERATURE.

Minerals and How to Study Them. A book for beginners in Mineralogy. By EDWARD S. DANA. 12mo, 380 pp. 319 figures.

This elementary book is especially welcome, as for a long time the need has been felt of such a work, by those who are commencing the study of mineralogy. For a full and proper understanding of the science there is needed a knowledge of chemistry, crystallography and physics, and to present the subject, therefore, so that it can be comprehended by beginners is not an easy matter. The books that have previously been available have either been so elementary that the science was not presented with sufficient clearness, or so technical and diffuse that beginners were almost discouraged in trying to become acquainted with the important facts of the science. One of the chief features of this new book is that the author has constantly kept in mind that the subject is being presented to beginners, the use of technical terms has, therefore, been wisely avoided and the subject-matter throughout the book is *readable*.

The first two short chapters are devoted to definitions and descriptions of the occurrence of minerals, and some hints as to how to study and collect them. The third chapter treats of crystallography and structure. The former is treated in a very elementary manner, the difficult mathematical relations are not gone into at all, and only the chief features and peculiarities of the six systems are given. The subject is illustrated not only by outline figures, such as one ordinarily sees in mineralogies, but also by some very excellent wood cuts illustrating pe-

cularities in the grouping and arrangement of crystals and the structure of minerals. Other physical properties such as cleavage, fracture, hardness, specific gravity, color, luster, etc., are treated briefly in the fourth chapter. In the fifth the chemical characters of minerals are discussed, and in the sixth the use of the blow-pipe and simple means of making chemical tests.

The seventh chapter, taking up about one-half of the volume, is devoted to a description of the mineral species. Of course only the common and important ones are considered, the chief features by means of which each mineral may be recognized being clearly brought out and its crystallization or structure well illustrated. The uses to which the mineral may be put are also given. The classification adopted is not the usual and more scientific chemical one, where the minerals are grouped according to the acid radicals, for example, the *sulphates* as one group, the *carbonates* as another, etc., but the minerals are grouped according to the different metals which they contain. In each case there is first given a brief account of the metal and its uses, followed by a description of the common minerals containing it. The silicates, owing to their complexity and the fact that, with few exceptions, they are not economically useful as ores of the metals, are treated in a group by themselves.

In the last chapter some simple rules for the identification of minerals by means of their physical properties are given.

The book is one which certainly will be found very useful, and a careful study of it in connection with a collection of mineral specimens will form an excellent foundation in the science.

S. L. PENFIELD.

The Elements of Botany. By FRANCIS DARWIN. Cambridge, University Press. 1894. Macmillan & Co., New York. \$1.60. Cambridge Natural Science Manuals.

It is a common habit of teachers and writers of botany to select a typical plant for study, one which shall illustrate within itself all the fundamental structures and life processes of plants. Francis Darwin in the volume before us takes up the problem at the other end: that is, he selects typical structures and phenomena and

studies each in some common plant which seems to show a given feature in its most undisguised state or condition. This is evidently the most natural method for the beginner, for it selects those emphatic types of plants which yield the fundamental lessons with the least desultory effort on the part of the student. There is no single plant which illustrates all the phenomena of plant life and structure with equal clearness, and the student who seeks to draw all his typical examples from the one species is likely to obtain only a faint impression of all those processes and anatomies which are more or less obscure in his specimen. But if the student is allowed to range for his material, or rather, if a wide range of material is placed before him, he is impressed rather with general and representative phenomena than with dissection and specialization.

It seems to me, therefore, that the plan of Mr. Darwin's book is excellent. He illustrates the fundamental conceptions of the cell, of reproduction, of nutrition and of fermentation, by the yeast-plant, spirogyra, tradescantia, clodea and elder pith; of reserve materials and germination by the bean and gourd, tubers of potato and artichoke and bulb of tulip; of the phenomena and structures of roots, by broad-bean; stem tissue by sunflower, and the like. The book is a reprint of lecture notes, and this accounts for its brevity and directness of style, and also, no doubt, for some inelegancies of construction. The book is wholly elementary and is divided into fourteen chapters to accommodate 'the work of fourteen mornings,' which comprises the scheme of botanical lectures in the course in elementary biology given at Cambridge, England, to medical students. The book also has an appendix comprising directions for fourteen laboratory exercises to correspond with the class-room instruction. A particularly worthy feature of the book is the steadfastness with which it adheres to the discussion of the particular type in hand, thereby omitting the modifications and exceptions which so often confuse the mind of the beginner.

It seems to be necessary to take issue with Mr. Darwin's interpretation of the morphology of the roseaceous flower. He designates the flower-cup, in which the cherry ovary sits, and

which comprises the greater part of the edible portion of the pome, as the receptacle, whilst Americans have been taught by Gray and others that this cup is a calyx-tube. This flower-cup of the drupaceous roseworts 'is the axis or receptacle of the flower which assumes this remarkable form. The hollowing out of the receptacle brings the points of origin of the calyx, petals and stamens above the ovary.' (P. 170.) The stamens are therefore borne upon the edge of the hollow receptacle rather than upon the throat of the calyx, as we have been taught, and this receptacle is *deciduous* in the drupes! It is generally held that the very proof of being a receptacle is the fact that it persists and bears the ripened fruit. If this cup-ring which falls off the drupe-fruit is really a receptacle, then it is difficult to explain the structure of the rubus flowers upon the same plan, for in them the stamens are clearly borne upon the calyx-rim, and the receptacle persists within the multiple 'fruit.' The only warrant for calling this flower-cup a receptacle is found in the rose-hip; but this organ proves itself a receptacle because it persists and because it bears the fruitlets scattered upon its interior. But the outside covering of the hip is, if analogies with other genera are true, a calyx-tube covering; and in some roses this calyx covering is almost free from the receptacle. It seems to be easy to demonstrate that the flesh outside the carpels or core in the pomes is thickened calyx, and not receptacle; for the carpels all spring directly from the apex of the pedicel (and not from an expanded and cup-like surface, as in the rose-hip), and the sepal tips still persist in the ripened 'fruit.' If the flower-cup in the roseworts is a calyx-tube, then the structure of the flower is fairly uniform in principle throughout the family; but if it is a receptacle in prunus and pyrus, then a different architecture of flower must be assumed for all the rubus-like, fragaria-like and spirea-like plants.

L. H. BAILEY.

An Introduction to the Study of Seaweeds. By GEORGE MURRAY, F. R. S. E., F. L. S., etc., Keeper of the Department of Botany, British Museum. London and New York, Macmillan & Co. 8vo. Cloth, 271 pp. 8 colored plates and 88 illustrations in the text. \$1.75.

The algæ are least well treated of all the groups of plants in the average text-book, although for purposes of morphological comparison and general phylogenetic consideration they are of the first importance. The author of this most valuable and welcome little book has shown such familiarity with his subject, and such appreciation of the relative importance of detail, that it is much to be regretted that he has confined himself to the marine members and has not treated the group as a whole.

The author has modestly entitled his book, 'An Introduction to the Study of Seaweeds,' but we may venture to predict that it will be used rather as a handbook both by the less advanced and by the more advanced student, combining, as it does, summaries and discussions of the very latest literature and personal researches with such convenience of form and simplicity of style of writing that it is not only valuable to the special student but available also to the general reader.

Mr. Murray, after a general introduction treating of the important topics concerning the seaweeds in general and the division of the group into the four ordinary subgroups fairly well characterized by their color, begins for purposes of convenience with the Olive-green or Brown Seaweeds. Starting with the more complicated forms of these, the rock-weeds and gulf-weeds or Sargassa, he proceeds to the less complicated forms, tracing the simplifications of structure and details of reproduction, step by step down to the lowest forms of the group. It is noticeable, however, that the simplest undoubted member of the group, the *Phæosaccion Collinsii*, described by Farlow from our New England coast, and by Rosenvinge from the Greenland coast, is omitted, whether purposely or not is not evident. It is, however, a form so different in its cylindrical thallus of a single layer of cells, without hairs and without specialized zoösporangia, that a discussion of its relationship with *Punctaria*, for example, would have been of very considerable interest.

The Grass-green Seaweeds follow the Olive-green, and while admirably treated are perhaps less interesting than the latter. It is interesting to note that *Codium* is removed from beside

Bryopsis and *Botrydium*, where it is very commonly placed and put into the heterogeneous assemblage of the Protococcaeae. We also notice that the animal-like *Ceratium*- and *Noctiluca*-forms find a place near them although of very doubtful affinities.

The Diatoms are placed by themselves as they well deserve to be, and even their superficial resemblance to the Desmids can hardly save them from the suspicion that their affinities are with organisms other than the undoubted seaweeds.

The Red Seaweeds are without question the most difficult and complicated group, not only in vegetative structure, but even more so in the details of the sexual reproduction. Mr. Murray's chapter was evidently written before Wille's paper announcing the discovery of the fusion of the two sexual nuclei had been published.

Schmitz's classification, based upon the variation in the development of the carpospores after the fertilization of the 'carpogonium,' has been followed, and this part will make accessible to the student an excellent account of Schmitz's system in a very convenient form.

The account of the Blue-green Seaweeds occupies the closing chapter of the book, and this is perhaps the least satisfactory part. The very interesting matter of the cell structure is very slightly touched upon, and the relationships between this group and other groups of organisms is barely hinted at. Considering the lack of general information about this group, even the comparative morphology might have received more attention.

It is pleasant to see that the author has not followed, in this book, the terminology of Benet and Murray's *Cryptogamic Botany*, but has used such words as *antheridia*, *carpogonium*, *sporangium*, and the like. The whole make-up of the book is very pleasing, the illustrations in the text are well selected and excellently reproduced, and the colored plates, interesting and valuable to the beginner for whom the book is intended, while lacking absolute accuracy of tint, are perhaps as good as the very low price at which the volume is sold would allow.

W. A. SETCHELL.

UNIVERSITY OF CALIFORNIA.

Korean Games, With Notes on the Corresponding Games of China and Japan. By STEWART CULIN, Director of the Museum of Archæology, University of Pennsylvania. Philadelphia. 1895. 1 vol. Large 4to. Pp. 177.

This handsome volume is a monograph of rare merit on a branch the importance of which is but imperfectly appreciated even by some of our most advanced ethnologists.

The subject of games, especially the games of children, has been generally regarded as beneath the dignity of real scientific treatment. They have been indulgently regarded as trivial pastimes, or, at best, as amusements only.

A quite different presentment of their significance is advanced in the work before us. The author, drawing most of his information from fresh and unpublished sources, describes ninety-seven games played by the youth of Korea, or by those of older years who retain the love of festal occupations. Some of them sound quite familiar, such as cards, chess, dominoes, dice, backgammon and blind man's buff; others have titles which seem remote from our experience as 'five gateways,' 'clam-shell combat,' 'water kicking' and 'corpse searching!' When, however, we come to examine even these, we recognize in most of them traits of familiar friends.

The methods of playing are explained, the terms employed are given in the Korean and often in the Chinese and Japanese tongues as well, and the position and costumes of the players and their utensils are depicted in twenty-two full-page colored plates by native artists and in 135 text illustrations, many of these also from native sources.

This is the basis of the study, and along with four elaborate indexes, one general and three of names in the languages referred to, make up the bulk of the volume. But the portion which will deservedly attract the thoughtful student beyond this is the Introduction, covering twenty pages, in which the author sets forth with singular lucidity the position which games should hold in ethnologic investigation. This is full of novel and original suggestions, the results not merely of the present monograph, but of years of study of the games of the world.

He claims, and one must concede with the strongest evidence in his support, that games

were originally not festal, but divinatory. Our ordinary checker board represents in its origin the conception of the universe common to nearly all tribes in a primitive condition. The numbers of our cards can be traced back to certain numerical categories and relations which profoundly affected the personal and social life of early tribes and peoples. The diversions of children are survivals of divinatory rites on which depended at one time the actions of mighty states. The magical implement which beyond any other was popular in early divination was the arrow; and the author, in a masterly manner and with rare insight, traces its later development under many transformations down to our cards of the present day. He shows that such evolution was not a transfer from one nation to another, but independent, though closely parallel, in Asia and America; and thus adds one more proof of the universal oneness of human intelligence. This volume will certainly mark an epoch in the proper understanding of what games are in the domain of anthropologic science.

D. G. BRINTON.

SCIENTIFIC JOURNALS.

THE AMERICAN JOURNAL OF SCIENCE,
DECEMBER.

THE number opens with an article by B. O. Peirce and R. W. Willson on the temperature variation of the thermal conductivities of marble and slate. This is an advance publication of the methods and results of an investigation carried on under the auspices of the Rumford Committee of the American Academy of Arts and Sciences. The important result is arrived at that, in the case of the slabs of marble experimented upon, the conductivity remains sensibly constant throughout the whole range of temperature employed, say from about 40° to above 300°. In the case of slate there was found an apparent increase of conductivity of about 30 per cent. between 70° and 300°. E. Cutter describes a practical method of obtaining the keynote of an auditorium. The stratigraphy of the Kansas coal measures is discussed at length by E. Haworth; the article is illustrated by a map of the eastern part of the State and two vertical sections, one a detailed section of the diamond

drill core obtained from the Topeka well, and the other a general section of the coal measures. E. H. Mudge discusses the post-glacial submergence in its relation to central Michigan. W. H. Weed and L. V. Pirsson describe certain igneous rocks of Yogo Peak in the Little Belt Mountains, Montana. They show that Yogo Peak is composed of a core or stock of massive, granular, igneous rock, and that this rock is composed chiefly of augite and orthoclase. The mass shows a progressive differentiation along its east and west axis, with a continual increase in the ferro-magnesian elements over the feldspathic ones. The resultant rock types are classified into three groups: syenite, where feldspar exceeds augite; *yogoite*, where they are practically equal, and *shonkinite*, where the augite dominates, the latter being similar to a rock type previously described.

S. L. Penfield gives directions in regard to the practical use of Retgers liquid to separate minerals of high specific gravity. This liquid consists of a mixture of silver and thallium nitrates fusing at 75° C. and having a specific gravity above 4.5. W. M. Foote gives a preliminary account of a new mineral named *northupite*; this is a chloro-carbonate of sodium and magnesium, and occurs in isometric octahedrons at Borax Lake, California. O. C. Marsh discusses at length the 'Affinities and Classification of the Dinosaurian Reptiles.' This article is accompanied by a large plate giving figures (restorations) of twelve typical dinosaurs, eight American and four foreign species. J. B. Woodworth describes some reptilian foot prints in the sandstone of Avondale, New Jersey. A brief communication by Alexander Agassiz, among the notes and abstracts which close the number, gives some preliminary results of observations of temperature made at great depths in one of the Lake Superior copper mines. The deepest point at which the temperature was taken was 4,580 feet and the temperature was only 79° F. Taking a depth of 105 feet as that unaffected by local temperatures, a column of 4,475 feet of rock is obtained with a difference of temperature of only 20°, or an average increase at the remarkably low rate of 1° F. for 223.7 feet of descent. The usual rate is about 1° F. to fifty feet.

PSYCHE, DECEMBER.

PROF. VERNON KELLOGG discusses the nomenclature of the venation of the wings in insects, with special reference to the veins in Epheméridæ termed premedia and postmedia by Comstock, which the author does not regard as independent veins; illustrative figures are given. Dr. A. Davidson gives some notes on the nest and parasites of a California bee, *Prosopis vari-frons*, one of the parasites being described as new by Ashmead. By the aid of a new figure, Mr. H. G. Dyar corrects his former account of the arrangement of the hairs in the larva of *Apatelodes torrefacta*, and discusses the number of its stages. Miss C. G. Soule describes the early stages of *Deidamia inscripta*, and Mr. F. H. Sprague records the capture of the large Acridian, *Schistocerca americana*, near Boston, Mass. An account (already published in SCIENCE) is given of the insect collection of the United States National Museum, and the Proceedings of the Cambridge Entomological Club for October are added. In a supplement are illustrated papers from the New Mexico Agricultural Station by Cockerell, Baker and Gillette describing various insects, with some account of their habits.

SOCIETIES AND ACADEMIES.

BIOLOGICAL SOCIETY OF WASHINGTON, 249TH MEETING, SATURDAY, NOVEMBER 16.

PROF. BARTON W. EVERMANN presented a paper on the fishes of the Missouri River Basin.

In its relation to the distribution of its fishes the Missouri Basin may be divided into three parts, viz.: 1. The western or mountainous portion, which is heavily timbered with coniferous forests, which has an abundant rainfall, and whose streams are clear, cold and pure. 2. The middle belt, extending from the forest covered mountains on the west to the western limit of abundant rainfall and deciduous forests on the east, a broad region with limited vegetation and rainfall, large areas of alkali soil which erodes very easily, and whose streams are shallow, shifting and full of alkali and solid matter in suspension. 3. The eastern belt, covered with deciduous trees, possessing abundant moisture, and whose streams are fairly clear and pure, though not cold.

The total number of fishes known to occur in the Missouri Basin is 140 species, representing 24 families and 68 genera.

The principal families represented are the following: Cyprinidæ, 49 species; Percidæ, 20 species; Catostomidæ, 15 species; Centrarchidæ, 12 species; Siluridæ, 10 species.

The great majority of the species are found only in the eastern belt, over 100 of the 140 being found only east of the 102d meridian. Only 11 species are characteristic of the western belt, and only 45 species are known from the Missouri Basin portions of North Dakota, Montana, Wyoming and Colorado.

In the middle belt there are few species and all the fishes there have a more or less bleached appearance, as a result of the peculiar environment of the alkaline water. Perhaps the best example of bleaching is seen in the flat-headed minnow (*Platygobio gracilis*) which, of all fishes, seems best adapted to these conditions.

One of the most interesting results of the field work upon which the paper was based was the definite determination of the westward limit of spiny-rayed fishes. West of the 96th meridian only a dozen species of this large group are known. Three species were found as far west as 98°38', while only a single specimen (*Etheostoma iowæ*) was found as far west as 100°30'.

Dr. Frank Baker spoke of the nomenclature of nerve cells, calling attention to the unsatisfactory character of the terms hitherto proposed for the elementary units of the nervous system. The following were especially mentioned:

Neuron (Waldeyer), has the form of a collective; *neurodendron* (Kölliker), cumbrous and not characteristic of all stages; *neura* (Rauber), has the form of a plural.

The term *neure* seems better and lends itself well to combination. The cells of the nerve roots (*cellules radiculaires*, von Gehuchten), could be called *rhizoneures*, the columnar cells (*cellules des cordons*), *axoneures*; commissural cells (*cellules des voies courtes*) would be *zygoneures*; long-path cells like those of the pyramidal tract (*cellules des voies longues*) would be *macro-dromic neures*, from Gr. μακρος, δρόμος, long course. Rhizoneures could be divided into neures of sensation, *æsthësi-neures* and neures

of action, *myoneures*. The latter term may perhaps be improved. Further subdivisions could readily be made when found necessary.

Prof. Edw. L. Greene read a paper on some fundamentals of nomenclature.

F. A. LUCAS, *Recording Secretary*.

NEW YORK ACADEMY OF SCIENCES, NOVEMBER 18, 1895.

THE Academy met with Vice-President Stevenson in the chair. The Section of Geology and Mineralogy immediately organized.

The first paper was read by Prof. J. J. Stevenson: 'Geological Notes on the Indian Territory.'

During a visit to Indian Territory in 1895 some observations were made which may aid in bringing together the results obtained in Arkansas and Indian Territory by Messrs. Winslow, Hill, Chance and Griswold, and which suggest relationships between the Carboniferous of Arkansas, Indian Territory and Texas.

The grouping of the coal measures presented by Mr. Winslow for Arkansas answers almost equally well for the eastern part of Indian Territory, as appears from Dr. Chance's sections, though some of the sub-divisions are wanting in the Territory and the bottom of the section is not reached, there being, yet lower, a very important limestone in the Choctaw nation. The workable coal beds of the territory are in the lower portion of the section,—the Booneville stage of Arkansas, at least 2,000 ft. lower than the Spadra semi-anthracites. At present they appear to be available only within the Choctaw nation, along the Choctaw and the Missouri, Kansas & Texas railways. The limestone, of undetermined thickness, belongs to the coal measures as is shown by the fossils. An asphaltic limestone occurs near Dougherty in the Chickasaw nation, apparently not far from the same horizon. Its fossils show it to belong to the Bend stage of Texas.

The Ouachita mountain system of Arkansas and eastern Indian Territory appears to be independent of the Tishomingo and Arbuckle mountain system, which is in the Chickasaw nation and apparently older than the other. The structure of the Ouachita system is beautifully simple and thoroughly Appalachian,

while that of the Chickasaw system is exceedingly complex. The curving trend shown by the Ouachita is so characteristic that one may venture to suggest that in Arkansas it may prove continuous with folds extending into Missouri. Its southern continuation appears to be buried under the Cretaceous overlap of Texas, which, as described by Prof. Hill, completely masks the older structure.

The paper will appear in full in the transactions of even date.

The second paper of the evening was read by Prof. J. F. Kemp: 'Zinc and Lead Mines in Southwestern Virginia.'

The paper was based on a visit of the speaker to the mines the past summer. He first showed their geographical distribution and the general geology of the country. By means of lantern views from photographs taken on the spot, the excessive sub-aerial decay of the blende-bearing limestones was made clear, and the occurrence of the zinc in the mineral calamine as crusts upon the undecomposed limestone and beneath the overlying mantle of clay. It was stated that the chemical reactions which had led to the formation of the ore must have taken place at the ordinary temperatures, and must have been produced by common agents, such as carbonated atmospheric waters, sulphuric acid and sulphate of zinc, produced by the decay of the blende, and silicic acid, from the silica in the original limestone. The speaker did not attempt to elucidate the matter further, but cited it as an interesting subject for experiment and investigation.

J. F. KEMP,

Recording Secretary.

AMERICAN CHEMICAL SOCIETY, MEETING OF NOVEMBER 8, 1895.

THE regular meeting was held in the hall of the Mott Memorial Library at 64 Madison avenue, Prof. P. T. Austen in the chair.

The minutes of the previous meeting were read and approved.

The Secretary reported that the letter authorized to be prepared in regard to the death of Louis Pasteur had been received from the Committee and duly forwarded to the French Chemical Society.

Prof. W. P. Mason's paper on 'The Chemical

vs. the Biological Examination of Water' was read by Prof. McMurtrie, in the absence of the author.

In the discussion which followed, the opinion was general that to arrive at a sound conclusion it is necessary to make both examinations, and ... tion all possible should be known of the history of a water.

Prof. McMurtrie stated that in examining a large number of wells in the State of Illinois he found no cases of typhoid fever resulting from the use of well waters in which the nitrites, free and albumenoid ammonia were all low.

These determinations, in conjunction with careful investigation of the history of a water, he found a pretty safe guide to an opinion.

Dr. Horne described an interesting case of large increase of nitrites on mixing three water supplies, the nitrites being low in each of the waters tested separately. Prof. Speyers suggested that the presence of hydrogen sulfid, or other reducing agent in one of the waters, acting on nitrates in the others, might produce this phenomenon.

A paper 'On the Heat of Solution of Certain Carbon Compounds' was read by Prof. C. L. Speyers.

Dr. Austen read a "Note on Runge's 'Bildungstrieb' of Substances," and exhibited a copy of this old and rare work.

Mr. Cutts read a paper, by T. S. Gladding, 'On the Gravimetric Method of Determining Phosphoric Acid by the Phospho-Molybdate Method.'

'Specimens showing the Effects of Gun Cotton Explosions' were exhibited by Mr. W. H. Burleigh.

The meeting was then adjourned to the second Friday in December.

DURAND WOODMAN, *Secretary*.

BOSTON SOCIETY OF NATURAL HISTORY.

THE Society met for the first meeting of the season on November 6th; 116 persons were present.

The presentation of papers by title, and matters of business announced, the Society listened to Prof. George Lincoln Goodale, who spoke on some peculiarities of Australasian vegetation. Limiting his remarks chiefly to Australia, Prof.

Goodale alluded to the natural and political divisions of that vast island-continent and described, with the aid of a series of lantern slides, some of the chief characteristics of its flora, the northeastern shores fringed with mangroves, the distinctness of the desert vegetation, the size and magnificence of the giant Eucalypts, and the interesting features of species of Acacia and Casuarina and of tree ferns. Attention was called to the vast number of genera and species that constitute the Australian flora, a single lantern slide showing at a moderate estimate more than 150 species; the total number of species found in Australia is estimated at about 10,000. Australian vegetation is supposed to have been derived from some point westward of the continent.

SAMUEL HENSHAW, *Secretary*.

NEW BOOKS.

Electricity and Magnetism. FRANCIS E. NIPHER. St. Louis, Mo. 1895. Pp. xi+426. \$3.25.

The Intellectual Rise of Electricity. PARK BENJAMIN. New York, D. Appleton & Co. 1895. Pp. 611.

Transmissions par câbles Métalliques. H. LÉAUTÉ and A. BÉRARD. Gauthier-Villars et fils and G. Masson. Pp. 184.

Les Nouvelles Théories Chimiques. A. ÉTARD. Paris, G. Masson and Gauthier-Villars et fils. Pp. 196.

Guide d'océanographie. J. THOULET. G. Masson and Gauthier-Villars et fils. 1895. Pp. 224.

Histoire de la philosophie atomistique. LÉOPOLD MABILLEAU. Paris, Félix Alcan. Pp. 560.

De Saint-Louis a Tripoli par le lac Tchad. P. L. MONTELL. Paris, Félix Alcan. Pp. 462.

The Story of the Indian. GEORGE BIRD GRINNELL. New York, D. Appleton & Co. 1895. Pp. x+270. \$1.50.

The Story of the Earth. H. G. SEELEY. New York, D. Appleton & Co. Pp. vi+186. 40 cts.

Der Schuss. FREDERICK BRANDEIS. Vienna, Pesth and Leipzig, A. Hartleben. 1895. Pp. 280.

Englische Chrestomathie. Vienna, Pesth and Leipzig, A. Hartleben. 1895. Pp. 182.

SCIENCE

NEW SERIES.
VOL. II. No. 50.

FRIDAY, DECEMBER 13, 1895.

SINGLE COPIES, 15 CTS.
ANNUAL SUBSCRIPTION, \$5.00.

GUSTAV E. STECHERT'S

Recent Importation of Scientific Books.

APEL, DR. MAX. Kants Erkenntnistheorie u. seine Stellung zur Metaphysik. Eine Einführung in d. Studium von Kants Kritik der reinen Vernunft. 147 Seiten. 8°. Mk. 3⁰⁰.

BAAS, J. HERM. Die geschichtliche Entwicklung des ärztlichen Standes u. der medicinischen Wissenschaften. Mit 2 Abbildg. 480 Seiten. gr. 8°. Mk. 11⁰⁰.

BIEDERMANN, W. Electrophysiologie. 2^{te} Abtheilung. Mit 149 Abbildungen. 857 Seiten. gr. 8°. Mk. 9⁰⁰.

BUCHKA, DR. KARL VON. Physikalisch-chemische Tabellen der anorganischen Chemie. 348 Seiten. gr. 8°. Mk. 10⁰⁰.

FUCHS, DR. GOFTHOLD. Anleitung zur Molekular-gewichtsbestimmung nach der 'Beckmannschen' Gefrier- u. Siedepunktmethode. Mit 18 Text Figuren. 14 Seiten. Cloth. M. 1²⁰.

GERARD, ERIC. Mesures electriques. Leçons professées a l' institut electrotechnique 'Montefiore annexé a l' université de Liège, Avec 198 figures dans le texte. 457 pages. Cloth. Francs 12⁰⁰.

GOMPERZ, THEOD. Griechische Denker. Eine Geschichte der antiken Philosophie. 1^{ster} Band. 478 Seiten. gr. 8°. Mk. 10⁰⁰.

GRUNMACH, DR. LEO. Lehrbuch der magnetischen u. electrischen Maasseinheiten, Messmethoden u. Messapparate. Mit 342 in den Text gedr. Holzschnitten u. vielen Tabellen. 632 Seiten. Mk. 16⁰⁰.

HAMMARSTEN, OLOF. Lehrbuch der physiologischen Chemie. 3^{te} völlig umgearb. Auflage. Mit Spectraltaf. 647 Seiten. gr. 8°. Mk. 14⁰⁰.

KIPPENBERGER, DR. KARL. Beiträge zur Reinsolirung, quantitativen Trennung u. chemischen Charakteristik von Alkaloiden u. glycosidartigen Körpern in forensen Fällen, mit besonderer Rücksicht auf den Nachweis derselben in verwesenden Cadavern. 58 Seiten. 8°. Mk. 1⁰⁰.

KISSLING, P. B. Beiträge zur Kenntniss des Einflusses der chemischen Lichtintensität auf die Vegetation. 28 Seiten. gr. 8°, mit 3 Platten. Mk. 3⁰⁰.

KRATTER, DR. JUL. Der Tod durch Electricität. Eine forensisch-medicin. Studie auf experimenteller Grundlage. Mit 7 Abbildg. u. Tafeln. 159 Seiten. gr. 8°. Mk. 7⁰⁰.

LE BLANC, DR. MAX. Lehrbuch der Electrochemie. Mit 32 Figuren. 226 Seiten. 8°. Mk. 4⁸⁰.

LEVY, S. Anleitung zur Darstellung organisch-chemischer Präparate. 3^{te} neu bearbeitete u. erweiterte Auflage herausg. v. Dr. A. Bistrzycki. Mit 35 in den Text gedr. Holzschnitten. 210 Seiten. 8°. In paper, Mk. 4⁰⁰; in cloth, Mk. 5⁰⁰.

MÜLLER, E. Die vermittelnden Inductionsstörungen im Fernsprechbetriebe u. deren Beseitigung. 65 Seiten. 8°. Mk. 2⁴⁰.

NERNST, W. U. A. SCHÖNFLIES. Einführung in die mathematische Behandlung der Naturwissenschaften. Kurzgefasstes Lehrbuch der Differential- u. Integralrechnung mit besonderer Berücksichtigung der Chemie. Mit 61 im Text befindl. Figuren. 309 Seiten. gr. 8°. Mk. 8⁰⁰.

OSTWALD, WILH. Die Ueberwindung des wissenschaftlichen Materialismus. Vortrag, gehalten i. d. Versammlung d. Naturforscher u. Aerzte zu Lübeck am 20^{ten} September, 1895. 36 Seiten. 8°. Mk. 1⁰⁰.

PAULSEN, DR. FEDR. Geschichte des gelehrten Unterrichts auf den deutschen Schulen u. Universitäten vom Ausgange des Mittelalters bis zur Gegenwart. 2^{te} umgearb. u. sehr erweiterte Aufl. 1^{ter} Halbband. 320 Seiten. gr. 8°. Mk. 7⁰⁰.

PLÜCKERS, JULIUS. Gesammelte wissenschaftl. Abhandlungen. Im Auftrage d. Kgl. Gesellschaft d. Wissenschaften zu Göttingen, herausgegeben v. A. Schönflies und Pockels. 1^{er} Band. Mathematische Abhandlungen, herausgegeben von A. Schönflies. Mit einem Bildniss und 73 Figuren. 620 Seiten. gr. 8°. Mk. 20⁰⁰.

PREYER, W. Die Seele des Kindes. Beobachtungen über die geistige Entwicklung des Menschen in den ersten Lebensjahren. 4^{te} Aufl. 462 Seiten. 8°. Mk. 8⁰⁰.

SMITH, DR. AUGUST. Die Alkoholfrage u. ihre Bedeutung für Volkswohl u. Volksgesundheit. Eine social-medicinische Studie für Aerzte u. gebildete Laien. Mit 7 Abbildungen. 127 Seiten. 8°. Mk. 2⁸⁰.

SRAUL, DR. ALEX. Erläuterungen zur qualitativen Analyse anorganischer Körper in Bezug auf die practischen Hilfsmittel u. den planmässigen Gang derselben. Mit 50 Abbildg. im Text. 173 Seiten. 8°. 3⁰⁰.

WEHMER, DR. C. Beiträge zur Kenntniss einheimischer Pilze. Experimentelle Untersuchungen auf dem Gebiete der Physiologie, Biologie u. Morphologie pilzlicher Organismen. II. Theil. Mit 3 Tafeln u. 6 Tabellen. 184 Seiten. gr. 8°. Mk. 7⁹⁰.

GUSTAV E. STECHERT,

810 Broadway, New York.

Macmillan & Co.'s Recent Publications.

Essays in Taxation.

By EDWIN R. A. SELIGMAN, Professor of Political Economy and Finance, Columbia College. 8vo, cloth, pp. x, 434. Price, \$3.00 *net*.

The Law of Civilization and Decay.

An Essay on History. By BROOKS ADAMS. 8vo, cloth, \$2.50.

The Beginning of the Middle Ages.

By the Late R. W. CHURCH, M. A., D. C. L., Sometime Dean of St. Paul's, Rector of Whatley, Fellow of Oriel College. 12mo, cloth (Eversley Series), \$1.50.

Acton.—A Lecture on the Study of History.

Delivered at Cambridge, June 11, 1895. By LORD ACTON, LL. D., D. C. L., Regius Professor of Modern History. 12mo, cloth, 75 cents.

Herodotus.—The Fourth, Fifth and Sixth Books.

With Introduction, Notes, Appendices, Indices. Maps by REGINALD WALTER MACAN, M. A., Fellow and Tutor of University College, Oxford, and University Reader in Ancient History. Vol. I., *Introduction, Text with Notes.* Vol. II., *Appendices, Indices and Notes.* 2 vols., 8vo, cloth, \$7.50 *en*

Browning Studies.

Being Select Papers by Members of the Browning Society. Edited with an introduction by EDWARD BERDOE, M. R. C. S., author of "The Browning Cyclopaedia," etc. 8vo, cloth, \$2.25.

Century Science Series.

Edited by SIR HENRY E. ROSCOE, D. C. L., F. R. S.

NEW VOLUME.

Lyell.—Charles Lyell and Modern Geology. By PROF. T. G. BONNEY, D. Sc., LL. D., F. R. S., etc. With Portrait. 12mo, cloth, \$1.25.

Tait.—Dynamics.

By P. G. TAIT, M. A., Sec. R. S. E., Honorary Fellow of St. Peter's College, Cambridge, Professor of Natural Philosophy in the University of Edinburgh. 12mo, cloth, \$2.50 *net*.

Menschutkin.—Analytical Chemistry.

By N. MENSCHUTKIN, Professor in the University of St. Petersburg. Translated from the Third German Edition, under the supervision of the author, by James Locke. 8vo, cloth, \$4.00 *net*.

Meyrick.—A Handbook of British Lepidoptera.

By EDWARD MEYRICK, B. A., F. Z. S., F. E. S., Assistant Master of Marlborough College. With Illustrations. 12mo, cloth, \$3.75.

MACMILLAN & CO., 66 Fifth Avenue, New York.

SCIENCE

EDITORIAL COMMITTEE: S. NEWCOMB, Mathematics; R. S. WOODWARD, Mechanics; E. C. PICKERING, Astronomy; T. C. MENDENHALL, Physics; R. H. THURSTON, Engineering; IRA REMSEN, Chemistry; J. LE CONTE, Geology; W. M. DAVIS, Physiography; O. C. MARSH, Paleontology; W. K. BROOKS, Invertebrate Zoölogy; C. HART MERRIAM, Vertebrate Zoölogy; S. H. SCUDDER, Entomology; N. L. BRITTON, Botany; HENRY F. OSBORN, General Biology; H. P. BOWDITCH, Physiology; J. S. BILLINGS, Hygiene; J. MCKEEN CATTELL, Psychology; DANIEL G. BRINTON, J. W. POWELL, Anthropology.

FRIDAY, DECEMBER 13, 1895.

CONTENTS:

| | |
|---|-----|
| <i>The Berne Physiological Congress</i> | 781 |
| <i>American Ornithologists' Union</i> : JOHN H. SAGE..... | 785 |
| <i>Geologic Atlas of the United States</i> | 787 |
| <i>A Glacier on the Montana Rockies</i> : L. W. CHANEY, JR..... | 792 |
| <i>The Huxley Memorial</i> | 796 |
| <i>Current Notes on Anthropology (XV)</i> :— <i>Ancient Mexican Mosaic Work; Euskarian Ethnology; Mayan Hieroglyphical Studies</i> : D. G. BRINTON..... | 800 |
| <i>Scientific Notes and News</i> :— <i>Letter of the Local Committee of the Scientific Societies; Metric System in Great Britain; Preservation of Forests; Fast Trains in Great Britain and the United States; General</i> | 801 |
| <i>University and Educational News</i> :— <i>The Building for Physics at the University of Kansas; The William Pepper Laboratory of Clinical Medicine; General</i> | 806 |
| <i>Correspondence</i> :— <i>The Perception of Direction</i> : MANLY MILES..... | 808 |
| <i>Scientific Literature</i> :— <i>Thomson's Elements of the Mathematical Theory of Electricity and Magnetism; Nipher's Electricity and Magnetism</i> : ARTHUR G. WEBSTER. <i>Wings on Brazilian Apes</i> . GERRIT S. MILLER, JR. <i>Whiteaves' Paleozoic Fossils</i> . J. F. J. <i>Contributions to a Biography of Linnæus</i> : J. A. UDDEN..... | 809 |
| <i>Scientific Journals</i> :— <i>Physical Review; American Meteorological Journal; The Psychological Review; The Botanical Gazette</i> | 816 |
| <i>Academies and Societies</i> :— <i>National Geographic Society</i> : W. F. MORSELL. <i>Scientific Association of the Johns Hopkins University</i> : CHAS. LANE POOR. <i>Geological Conference of Harvard University</i> : T. A. JAGGAR, JR..... | 820 |
| <i>New Books</i> | 824 |

MSS. intended for publication and books, etc., intended for review should be sent to the responsible editor, Prof. J. McKeen Cattell, Garrison on Hudson, N. Y.
Subscriptions and advertisements should be sent to SCIENCE, 41 N. Queen St., Lancaster, Pa., or 41 East 49th St., New York.

THE BERNE PHYSIOLOGICAL CONGRESS (I.)

THE third International Physiological Congress, held at Berne from September 9th to 13th, 1895, was attended by a larger number of physiologists than either of the previous meetings. The official lists of those who announced their intention of being present contained 154 names, and, though a few of these were prevented from attending, the representation from most of the European countries was very satisfactory. The United States, however, sent but two representatives.

The meetings were held in the new physiological institute named in honor of Switzerland's great physiologist the 'Hallerianum.' Here every facility was offered by Prof. Kronecker and his assistants, not only for the presentation of the regular communications, but also for the exhibition of apparatus and for physiological and microscopical demonstrations, which are really the most important features of such gatherings.

The social entertainments were numerous and well arranged. On the evening of September 8th an informal reception in the Gesellschaftshaus gave the members an opportunity of greeting each other and of making new acquaintances. On the following evening Prof. and Mrs. Kronecker received the members at their home and entertained them with private theatricals, dancing and an 'Abendessen' in the open air. The other social features of the Congress

were a concert in the Cathedral with a subsequent reunion in the Café du Pont, an excursion to the Schynige Platte (somewhat interfered with by bad weather), a subscription dinner followed by a ball and a reunion in the 'Festhalle' of the agricultural exhibition.

In the business session the Congress adopted rules for the admission of members to future meetings and voted that the next Congress should be held in Cambridge, England, in 1898.

The physiological proceedings were the following:

Monday, September 9th. Morning demonstrations and papers. (Chairmen, Profs. Chauveau and Bowditch.)

Dr. H. Boruttau (Göttingen) discussed the possibility of explaining the conduction of nervous impulses by purely electrical processes, and demonstrated on the polarizable 'Kernleiter' of Matteucci and Hermann with the aid of capillary electrometer and of reflecting galvanometer the production of a negative variation by tetanic sinusoidal 'stimulation,' and by rupture of the Kernleiter. With Hermann's rheotome, too, a wave of negativity was shown to be produced in the Kernleiter analogous to that of a nerve.

Prof. R. Ewald (Strassburg) showed a dog from the spinal cord of which a length of 158 mm., comprising the whole of the lumbar enlargement and a large part of the thoracic region, had been removed more than two years before in two operations. The alimentary canal continued its normal functions; the urine, free from sugar and albumen, accumulated in large quantities in the bladder, which emptied itself at intervals; vascular tonus had become normally restored; and there were no trophic cutaneous lesions. With the exception of the sphincter ani, which still functioned normally and retained electric excitability, the muscles supplied by the portion of the

cord removed were completely degenerated. An animal similarly operated on bore young naturally, one of which was still alive, and suckled them.

Discussion by Profs. Kühne, Rosenthal and Holmgren.

Prof. E. Fano (Florence) demonstrated a myographic method for the measurement of reaction-time in the dog by which he had found that removal of certain regions of the cerebral cortex causes a shortening of the reaction-time, while electrical stimulation of the same regions lengthens it. He believes the conclusion justified that the cells of the cerebral cortex, especially of the frontal lobes, exercise an inhibition on the spinal cord.

Prof. N. Vitzu (Bucharest) had removed the occipital lobes of a dog's brain, and in the course of two years the consequent visual defect gradually improved. By a second operation of the same nature as the first, the animal became blind as before, while examination of the tissue removed showed it to be very vascular and to contain ganglion cells. These Prof. Vitzu held to be of new formation.

Discussion by Profs. Héger, Arloing and Herzen.

Dr. Demoor (Brussels) showed photographs and drawings of preparations made by Golgi's quick method of the cerebral cortex of dogs to which large doses of chloral or of morphine had been given. They showed a characteristic varicosity of the processes of the ganglion cells, absent in the case of unpoisoned and unexhausted animals, although killed in the same way. This action of the drugs in question was compared with a similar one exercised by them on the pseudopodia of amœbæ and on vegetable protoplasm. Dr. Demoor holds all three structures to be motile, a conclusion of interest in relation to the functions of ganglionic cells.

Dr. G. Mann (Edinburgh) discussed the

results of electrical stimulation of the cerebral cortex of the dog, cat, rabbit and hedgehog. He found that the method of relative arrangement of the different motor centers was in all the animals investigated essentially the same, although specific differences of location and of relative functional importance existed.

Mr. J. N. Langley (Cambridge) gave a general account based especially on his own researches of the sympathetic system, the fibres of which he classed as pre-ganglionic and post-ganglionic, according as they are central or peripheral (in relation to the central nervous system) to sympathetic ganglia. He discussed the nature of the 'reflexes' possible in sympathetic ganglia, and demonstrated such a one—stimulation of a post-ganglionic sympathetic trunk in the cat producing erection of the hairs covering a certain skin area. Stimulation of the corresponding pre-ganglionic trunk produced the same effect over a larger area.

Prof. J. Gaule (Zurich) gave the results of his investigation as to the growth of skeletal muscles. This is not continuous, but periods of increase are separated by periods of inactivity or even of decrease, in which crystals of calcium oxalate occur in the muscles. Faradic stimulation of long duration of the lower spinal ganglia caused in the periods of increase relative decrease; in the periods of inactivity relative increase.

Afternoon demonstrations and papers (Chairmen, Profs. Hensen and Mosso). Prof. A. Herzen (Lausanne) described the isolation of a dog's stomach made by himself and Dr. Frémont (Vichy), in a manner analogous to that of Thiry in the case of the small intestine. He showed some of the gastric juice obtained from the stomach; it was strongly acid, colorless and odorless, and capable of digesting its own weight of coagulated albumen. The amount daily secreted was 800 grams, which would correspond to 4 litres in the case of a man.

Prof. Herzen also described experiments tending to show that the spleen secretes internally a substance capable of developing digestive properties. The addition of blood from the splenic vein to pancreatic extract enables it to digest more actively ordinary arterial blood not having this action.

Discussion by Prof. Schiff.

Prof. M. Schiff (Geneva) gave the results of his investigation of the effect of local lesions of a bulbar pyramid. This does not produce degeneration of the corresponding crossed pyramidal tract or any motor disturbance.

Prof. R. Tigerstedt (Stockholm) described in detail his large apparatus for the investigation of the respiratory gaseous exchange. The respiration chamber has a content of 100 cubic meters and can contain several persons at once. Control experiments in which petroleum and stearin were burnt in the chamber showed an average error of 1.08%, *i. e.*, not more than that of Petterhofer and Voit's apparatus which was ten times smaller. Prof. Tigerstedt gave the results of an experiment on the effects of hunger made on himself and three others at the same time.

Discussion by Profs. Richet and Zuntz.

Dr. K. Gürber (Würzburg) described his modification of Hoffmeister's method for the preparation of crystals of serum-albumin from horse's serum. He had obtained four varieties of crystallized serum-albumin. If the crystals, after the removal of excess of ammonium sulphate, were heated to 67° C. in $\frac{2}{3}$ – $\frac{3}{4}$ % ammonium sulphate solution, they were coagulated and became insoluble without losing their crystalline form, although their power of double refraction disappeared, but returned after some weeks. Specimens of the crystals were shown under the microscope.

Prof. I. Rosenthal (Erlangen) demonstrated his Calorimeter.

Tuesday, September 10th. Morning

demonstrations and papers (Chairmen, Profs. Rutherford and Héger).

Dr. W. His, Jr. (Leipsic), discussed the mechanism of the heartbeat. He supported Engelmann's view of the purely muscular propagation of the contraction wave, not only in auricles and ventricles separately, but from auricles to ventricles also. He found in the rabbit, cat, dog and man a bundle of cross-stripped muscle fibres, which if experimentally divided produces often a short arrhythmic interval, a condition of allorhythmia in which auricles and ventricles beat at different rates. The muscular bundle in question contains no nervous elements. Dr. His was unable to confirm Stanley Kent's results.

Prof. K. Hürthle (Breslau) demonstrated his method for determining plethysmographically the blood pressure in man. An arm is first made bloodless by the Esmarch bandage, and is then introduced into a closely fitting india-rubber case connected with a 'Gummi-' or 'Federmanometer.' On re-entry of blood into the arm the pressure rises in about half a minute to its full length, a pulse curve being then recorded.

Discussion by Prof. Mosso.

Dr. K. Kaiser (Heidelberg) gave his views on the causation of the rhythmical contraction of the frog's heart, which he considers due to nervous apparatus. The heart muscle itself is unable to respond rhythmically to a constant stimulus, as has been hitherto supposed. Dr. Kaiser showed experiments on the frog's heart in favor of his views.

Discussion by Mr. Langley, Prof. Burdon Sanderson, Dr. His, Jr., and Prof. Schiff.

Prof. H. Kronecker (Berne) showed an experiment consisting in the injection of paraffin (of melting point 39° C.) into the peripheral end of the descending coronary artery of a full-grown dog. The ventricles at once entered into fibrillary contractions

while the auricles continued to beat. Ligation of the artery does not produce this result. The conclusion drawn was that the normal heartbeat is brought about by the agency of nervous structures, easily affected by anæmia.

Dr. R. Magnus (Heidelberg) demonstrated his sphygmograph, which is applied to the end of a dissected-out artery. Curves, the ordinates of which are proportional to pressures, were shown.

Discussion by Dr. Cow and Prof. Fredericq.

Prof. N. Zuntz (Berlin) demonstrated his method for estimating the velocity of the blood stream, consisting in the determination of the rate at which blood must be injected into the carotid artery during vagus standstill in order to bring back and maintain the average blood pressure.

Dr. A. Beck (Lemberg) gave an account of his experiments with Cybulski's photo-hæmotachometer to determine the velocity of the blood stream in the dog's portal vein. He found it to be 2,000-2,800 cubic millimeters per second, which corresponds to 620-780 c. c. per gram of liver tissue in 24 hours. There are slight respiratory variations, but only large variations of general blood pressure produce much effect on velocity of blood stream in the portal vein.

Afternoon demonstrations and papers (Chairmen, Profs. Tigerstedt and Wedensky.)

Prof. A. Dastre (Paris) discussed the gradual dissolving of fresh fibrin in strong solutions of neutral salts at 40° C., in which process globulins, albumoses and peptones are formed. He analogised this action to that of peptic and pancreatic digestion, of micro-organisms, of oxygenated water, and of sterile distilled water at high temperatures and pressures. The hydrolysis of proteids is a general process to which ferments are not necessary. Gelatin is similarly acted on by salt solutions.

Discussion by Drs. De Rey-Pailhade and Arthus.

Prof. W. Einthoven (Leyden) showed photographs of the regular excursions of a capillary electrometer produced by a tuning fork giving as many as 1,000 vibrations per second. The results obtained on the other hand with Appunn's steel lamellæ were so irregular that these are apparently unsuitable for investigation of the deepest perceptible tones.

Prof. C. Sherrington (Liverpool) and Dr. F. Mott (London) showed two monkeys. One of these had had the posterior nerve roots, with the exception of the 8th cervical nerve, divided down to the 2nd dorsal nerve, with no resulting sensory or motor disturbance. The other monkey had, in addition, the posterior roots of the 8th cervical nerve divided, and showed motor as well as sensory disturbances. It was demonstrated to the Congress that these disturbances were not due to injury of the pyramidal track for stimulation of the cerebral motor area caused movements of the fore limb.

Prof. J. B. Haycraft (Cardiff) described the change of shape of the heart in systole. It was very difficult to produce post-mortem systolic contraction of the heart, but this could be done by injection of mercuric chloride. The results obtained confirmed those of Ludwig and Hesse.

Prof. F. Gotch (Oxford) described the results of his investigations of the nature of the discharge of *Malapterurus Electricus* in response to mechanical and electrical excitation with the help of galvanometer and rheotome, of rheoscopic nerve-muscle preparation, and of capillary electrometer provided with shunt or condenser. Each discharge consists of three or four single shocks following one another at intervals of .004-.005 seconds, each of which has a duration of .002 seconds and an electromotive force of 120-200 volts. The succession of shocks is probably due to each shock stimulating the

organ producing it to the production of a fresh one, and can be demonstrated with the organ isolated from the body.

Discussion by Dr. Boruttau and Prof. Rosenthal.

(To be concluded.)

AMERICAN ORNITHOLOGISTS' UNION.

THE Thirteenth Congress of the American Ornithologists' Union convened in Washington, Monday evening, November 11th. The business meeting was held at the residence of Dr. C. Hart Merriam. The public sessions, lasting three days, were held in the Lecture Hall of the U. S. National Museum, commencing Tuesday, November 12th.

William Brewster, Cambridge, Mass., was elected President; Dr. C. Hart Merriam and Mr. Robert Ridgway, of Washington, Vice-Presidents; John H. Sage, of Portland, Conn., Secretary; Wm. Dutcher, of New York City, Treasurer; Dr. J. A. Allen, Maj. C. E. Bendire, Frank M. Chapman, C. F. Batehelder, Dr. Elliott Coues, D. G. Elliot and Dr. A. K. Fisher, members of the Council. One active, one honorary, two corresponding and eighty-eight associate members were elected.

A communication was received from Dr. Ch. Wardell Stiles, delegate from the United States to the International Zoölogical Congress, requesting the Union to appoint a representative as a member of an Advisory Committee to which will be submitted all questions of nomenclature likely to be ruled on by the International Zoölogical Congress, to be held in England in 1898. Dr. J. A. Allen was so appointed.

The Committee on 'Classification and Nomenclature of North American Birds' reported the new edition of the Check-List as practically finished; it will be published in a few weeks.

In behalf of the Committee on 'Protection of North American Birds,' Mr. Wm. Dutcher stated that the same precautions

had been taken in 1895 as in 1894 regarding the protection of terns on Great Gull Island, New York. A game warden had been employed, several of the natural history societies in New York City contributing toward the payment of his salary. Absolutely no shooting had been done and parties who visited the island during the past year were prevented from collecting eggs.

Mr. Brewster said that the terns on Muskeget Island, Massachusetts, were steadily increasing in numbers, the result of protection. No birds had been shot on or near the island the past year. A notable increase was seen also in the colony of Laughing Gulls at the same place. Great credit is due Mr. Geo. H. Mackay for his continuous efforts in saving the gulls and terns on this island from destruction.

Mr. Witmer Stone knew of only one colony of terns on the New Jersey coast. As these birds nested back in the meadows and away from the coast, it was difficult to protect them. In recent years the 'egggers' had destroyed immense numbers of the eggs of the clapper rail which nested in favorable localities along the coast of New Jersey. This rail had increased the past season, as game wardens had watched the meadows and arrested several marauders.

Mr. Leverett M. Loomis remarked upon the wholesale destruction of birds and their eggs on the California coast during 1895.

Dr. Elliott Coues exhibited and explained a collection of unpublished water-color paintings of birds by Louis Agassiz Fuyertes. The artist is a student at Cornell University and his work shows marked talent.

Tuesday evening, November 12, a special public memorial meeting was held in the lecture hall of the National Museum in commemoration of the two distinguished honorary members of the Union who have died the past year. The late Geo. N. Lawrence was eulogized by Mr. D. G. Elliot and Prof. Thos. H. Huxley by Dr. Elliott Coues.

The following is a list of the papers read at the sessions :

- An Important Factor in the Study of Western Bird Life*: CARL F. BAKER.
On Pallas' Cormorant: F. A. LUCAS.
Further Remarks on the Subgenus Quiscalus: FRANK M. CHAPMAN.
On Gätké's Helligoland: GEO. H. MACKAY.
Food of the Meadow Lark: F. E. L. BEAL.
Methods in Economic Ornithology with special reference to the Catbird: S. D. JUDD.
Notes on the Birds of Idaho: M. J. ELROD.
The Pine Grosbeak (Pinicola enucleator) in Captivity: O. W. KNIGHT.
Midwinter Migration Southward in the North Temperate Zone to Breeding Grounds: LEVERETT M. LOOMIS.
Why are there so few Bluebirds? MRS. L. M. STEPHENSON.
On the Standing of Ardetta neoxena: FRANK M. CHAPMAN.
What Constitutes Publication? J. A. ALLEN.
The Value of the Tongue in the Classification of Birds: F. A. LUCAS.
Introduced Birds: T. S. PALMER.
A Critique on Trinomial Inconsistencies: WILLIAM PALMER.
The First Plumage of the Philadelphia Vireo (Vireo philadelphicus): JONATHAN DWIGHT, JR.
The Terns of Muskeget Island, Part II.: GEO. H. MACKAY.
A Few Effects of the Winter of 1895 upon the Spring and Fall Migration in Canton, Mass.: J. H. BOWLES.
Kingbird and Sapsuckers of Southern California: A. J. COOK.

Mr. Wm. Palmer gave an exhibition of lantern slides of birds, explanations being made by Messrs. Brewster, Palmer and Chapman.

The next meeting of the Union will be held in Cambridge, Mass., beginning November 9, 1896.

JNO. H. SAGE,
 Secretary.

GEOLOGIC ATLAS OF THE UNITED STATES (II).

FOLIO 11, JACKSON, CALIFORNIA, 1894.

THIS folio consists of 2 pages of text descriptive of the Gold Belt, concluding with a generalized section of the formations of the Gold Belt, 4 pages of text descriptive of the Jackson tract, signed by H. W. Turner, geologist, and G. F. Becker, geologist in charge; a topographic map of the Jackson tract (scale 1:125,000), a sheet showing the areal geology, and a third of structure sections.

The area covered by the folio embraces a portion of the foot hills of the Sierra Nevada, chiefly in the counties of Amador and Calaveras, California. The area is drained by the Mokelumne and Calaveras rivers. The region is one of great economic importance, and comprises a portion of the rich belt of gold-quartz mines known as the Mother Lode. One of these mines, the Utica, at Angel's Camp, is said to be paying about one million dollars yearly at the present time.

There are two distinct series of formations represented in this area. The Calaveras and Mariposa formations, of sedimentary origin, and the associated igneous rocks form an older, highly disturbed series, on which a later series rests with a marked unconformity. This later series represents the Tertiary and Pleistocene periods.

The Calaveras formation, of Carboniferous age, is composed of slates, quartzite, mica-schists and limestone lenses, and contains frequent gold-quartz veins. The Mariposa formation, of Jurassic age, is largely made up of clay slate. There are two main belts of this formation, and in the eastern one occur many of the gold-quartz mines of the Mother Lode.

The igneous rocks associated with the Calaveras and Mariposa formations are of considerable variety, but only three form areas of great extent. These are serpentine, granite and the porphyrites (old andesites)

and their tuffs. The serpentine is undoubtedly an altered form of basic igneous rocks (pyroxenite and peridotite), and is intrusive. The granite is likewise intrusive, cutting through all the older rocks except the Mariposa formation, and there is little doubt that it is later than this formation also, and in adjoining districts it invades the Mariposa slates as well. The porphyrites are largely altered forms of surface lavas and tuffs, resembling andesite and in part basalt, and these rocks, have been folded and compressed along with the sediments of the Calaveras and Mariposa formations. The areas called amphibolite schists on the geological map are chiefly metamorphic forms of these porphyrite tuffs.

The formation of the later series, resting on these older rocks, that deserves most attention is called the Auriferous gravel formation. These gravels, which are found chiefly on the ridge tops, were deposited in Neocene time by rivers. These old streams, as may be seen by inspecting the map, united into one trunk a little to the north of the Bear Mountains, and there found an outlet into the gulf that then filled the San Joaquin Valley. At many localities these old river gravels have been profitably mined for gold. Forming a capping to the gravels are usually beds of volcanic material, chiefly andesite and rhyolite.

The Calaveras formation is of economic importance as containing frequent gold-quartz veins and lenses of limestone. Most of the latter are noted on the geological map.

The Mariposa formation affords a good roofing slate, but is chiefly remarkable as containing, in Amador county and in the north portion of Calaveras county, the quartz veins of the Mother Lode.

The amphibolite-schist belts contain copper deposits and gold-quartz veins. In the southern part of Calaveras county, at Angel's Camp, the Mother Lode lies to the

east of the Mariposa slates and intersects a belt of amphibolite schist.

In the granite of the West Point are a numerous gold-quartz veins, the ores of which contain a larger per cent. of sulphurets than the ores of the Mother Lode mines, and such ores are called base.

The serpentine areas contain chrome-iron deposits at numerous points.

The tuffs overlying the gravels at Mokelumne Hill, Valley Springs and other points have been found to make good building stone. Sandstone quarries are marked in the foot hills in beds of Tertiary age, and the deposits of the same age near Ione afford large quantities of clay for pottery, and of coal.

FOLIO 12, ESTILLVILLE, KENTUCKY-VIRGINIA-TENNESSEE, 1894.

This folio consists of 5 pages of text by M. R. Campbell, geologist, a topographic map of the district (scale 1:125,000), a sheet showing the areal geology, another showing the economic geology, a third of structure sections, and a fourth giving a columnar section north of Clinch River and another south of that river.

The territory represented by the folio is located principally in southwestern Virginia, though the southern portion extends into Tennessee and the northwestern portion into Kentucky. Its area is 957 square miles, four-fifths of which is in the Appalachian Valley and one-fifth in the Cumberland coal basin.

The surface features are quite varied. In the Appalachian Valley they consist of a succession of narrow ridges separated by equally narrow valleys, trending in a northeast and southwest direction. In the coal basin the ridges are less regular, but higher, reaching in two cases an elevation of over 4,150 feet above the sea level.

The region is almost entirely within the drainage basin of the Tennessee River. The

principal tributaries of this stream are Holston, Clinch and Powell rivers, each of which is a stream of considerable importance. The Kentucky portion of the territory is drained by the headwaters of the Cumberland River.

The geologic structure of the region is complicated. In the Appalachian Valley the rocks have been squeezed, in a northwest and southeast direction, until they have been forced into great folds. These are generally overturned toward the northwest, and have in many cases been compressed to such an extent that they have broken, allowing one limb of the fold to be thrust over the other. These faults are of frequent occurrence in this region. Sixteen or seventeen can be counted on the geologic map. In the coal basin the folding is less severe, and the result is a broad basin in which dips are prevailingly light, and in many places the rocks are horizontal.

The intense folding of the strata has brought to the surface all of the geologic formations from the Carboniferous to the Cambrian. On lithologic grounds these are divided into twenty-two separate and distinct formations. As a result of the original folding and subsequent erosion, these formations show at the surface in long, narrow outcrops of limestone, shale or sandstone, which in the various folds are repeated over and over again. It is this repetition of the hard beds that gives rise to the numerous ridges which are such conspicuous features of Appalachian topography. In the coal basin the rocks are nearly horizontal, and hence they show in outcrop around the flanks of the mountains, or irregularly over the less rugged portions.

The mineral resources of this region are important, though at present but slightly developed. A belt of marble, varying considerably in composition and appearance, outcrops along the northern side of Clinch Mountain. Iron ore occurs in many parts

of this territory, both in the form of limonite and in that of hematite. Red fossil ore is found in the Rockwood formation in the northern part of the region, and it is mined on Wallen Ridge, south of Big Stone Gap. Coal is the principal mineral resource of this territory. It occurs in the structural basin north of Stone Mountain, and sparingly in the great arch of Powell Mountain, east of High Knob. The coal-bearing rocks are approximately 5,000 feet in thickness and include many seams of workable coal. In the vicinity of Big Stone Gap the Imboden seam is the most important. It has been traced over a large area on the Virginia side of the basin, where it varies from 3 to 16 feet in thickness. On this side there are a number of other seams of good quality, ranging from 3 to 5 feet in thickness, which could be easily worked. The Kentucky portion has also many workable seams, but at present, owing to lack of transportation, no mining has been done on a commercial scale.

FOLIO 13, FREDERICKSBURG, VIRGINIA-MARYLAND, 1894.

This folio consists of 5½ pages of text, signed by N. H. Darton, geologist, and W J McGee, geologist in charge; a topographic map of the district (scale 1:125,000), and a sheet showing the areal geology.

The map represents an area of approximately 1,000 square miles of the Coastal Plain region of northeastern Virginia and the southwestern corner of Charles county, Maryland. It includes, in Virginia, King George and the greater part of Caroline and Stafford counties and adjoining portions of Spottsylvania, Essex and Westmoreland counties. The city of Fredericksburg is near the center of the western margin of the area. The Potomac River crosses the northeastern corner of the area, and the Rappahannock River extends diagonally across its center on a northwest and south-

east line. The headwaters of the Mattapony River are in its southwestern corner. Along these river valleys there are wide, low terraces capped by the Columbia formation, of Pleistocene age. The intervening areas are plateau remnants capped by Lafayette deposits, of supposed Pliocene age. The underlying formations are the Potomac, Pamunkey and Chesapeake, which lie on an east-sloping floor of crystalline rocks. This floor rises to the surface and constitutes hills of considerable height in the northwestern corner of the tract; eastward it is deeply buried under the Mesozoic and Tertiary sediments. The Potomac formation, which is the basal member of these sediments, consists of a heterogeneous series of sands and sandstones with intercalated clays. Much of the sand is arkosic, and consists of detritus of crystalline rocks. The Pamunkey formation, which overlies the Potomac unconformably, is the representative of the Eocene in this region. It consists in greater part of glauconitic marls. These marls are important fertilizers, and in some portions of the region have been used with excellent results. They are overlain unconformably by the Chesapeake formation, which is of Miocene age. It is characterized by fine sands, marls and clays, portions of which consist largely of diatom remains. It is the same series that extends to Richmond, where its diatomaceous character was discovered many years ago, and to the northward through Maryland. It thickens rapidly eastward, and is nearly 1,000 feet thick in the lower Chesapeake Bay district.

The crystalline rocks consist mainly of granites and gneiss and an infolded belt of slates, to which the name Quantico slates has been given. They are not of value for roofing slates, so far as is now known. They appear to be a continuation of the slates in the belts west of Richmond in which lower Silurian fossils were discovered some time

ago, but no fossils have been found in the area of the Fredericksburg sheet.

FOLIO 11, STAUNTON, VIRGINIA-WEST VIRGINIA, 1894.

This folio consists of 4 pages of text, signed by N. H. Darton, geologist, and closing with a columnar section of the area; a topographic map (scale 1:125,000), a sheet showing the areal geology of the district, another showing the economic geology and a third exhibiting structure sections.

The area represented is about 1,000 square miles of central Appalachian Virginia. It comprises central and western Augusta county and portions of several adjacent counties. Staunton lies near the center of the eastern margin of the tract. About a third of the area is in the Great Valley of Virginia, and the remainder stretches halfway across to the Alleghany Mountains.

The geologic formations comprise members from the Shenandoah limestone of the Great Valley to the Pocono sandstone of Lower Carboniferous age. There are also some small dikes of diabase in the northwestern corner of the area. The region is one in which relatively gentle folds predominate. There is an overthrust fault which extends along the western side of the Great Valley for some distance, and several other faults traverse the Shenandoah limestone.

The geological classification does not differ materially from that outlined by W. B. Rogers, but geographic names have been applied to the formations. The name Shenandoah limestone has been selected for the great series of limestones of the valley. This series comprises several subdivisions, but in the Staunton region they merge so gradually that no attempt has been made to differentiate them on the map. The upper member contains a Trenton fauna, and it is thought that the basal beds of the se-

ries extends into the Cambrian, although no fossils have been discovered in them. Next, there is the representative of the Utica and Hudson shales, which has been designated the Martinsburg shale. It is overlain by the Massanutten sandstones, which comprise the Oneida and Medina in terms of the New York series. Next, there are the Rockwood formation and the Lewistown limestone, which include the formations between the Clinton and Lower Helderberg. The Oriskany and associated sediments are here represented by a stratigraphic unit to which the name Monterey sandstone has been given. The great series of Devonian strata lying above the Monterey has been divided into the Romney shale, Jennings formation and Hampshire formation. As they are not sharply separated from each other the patterns by which they are represented on the map are merged over a narrow zone along their boundaries. Only a portion of the Pocono formation is included in the stratigraphic column in this region.

The principal economic resources are iron ores, which lie on a local unconformity between the Monterey sandstone and the Romney shale, and limestone for flux. Some of the limestones are suitable for marbles, and at many points lime is burned for local use. There are several thin, irregular beds of coal in the Pocono sandstone, but they are not of economic importance. Brick and pottery clays in the Great Valley complete the list of economic resources.

FOLIO 15, LASSEN PEAK, CALIFORNIA, 1895.

This folio consists of 2 pages of text by J. S. Diller, geologist, descriptive of the Lassen Peak district, supplemented by two pages, with illustrations (9 figures), devoted to recent volcanic activity; a topographic map of the district, a sheet showing the areal geology and another showing the economic geology.

The Lassen Peak district is situated in

northern California, between the Sacramento Valley and the Great Basin, and adjoins the northern end of the Sierra Nevada. It is bounded by the 121st and 122d meridians and the 40th and 41st parallels, and contains an area of 3,634.4 square miles.

Within the district there are three distinct topographic features. Beginning at the west, it includes (1) a small portion of the eastern border of the Sacramento Valley, (2) the Lassen Peak volcanic ridge, and (3), upon the east, a portion of the Great Basin platform.

Twenty-two geological formations are shown upon the map. Thirteen of these were deposited by water as sedimentary rocks. The remaining nine are of igneous origin, and were erupted from the interior of the earth in a molten condition. Some of the sedimentary rocks, especially the younger ones, have not been materially changed since they were deposited, but others, such as the Auriferous slates, have been greatly altered or metamorphosed, and contain veins of quartz and metalliferous deposits.

By far the most abundant rocks of the Lassen Peak district are those of igneous origin. The numerous volcanoes of the district have furnished a great variety of such rocks.

Beds of unaltered stratified rocks, none of which are older than the Cretaceous, are still nearly horizontal; although uplifted, they have not been compressed enough to produce folds. On the other hand, the Auriferous slates have been thrown into a series of anticlines and synclines and so greatly compressed as not only to close the folds, leaving the strata in many cases approximately vertical, but also to break and displace them along a series of thrust faults during the earth movements by which the mountains were produced.

Upon the economic map special attention is called to the distribution of auriferous

slates, in which alone there is any probability of discovering valuable deposits of precious metals. These rocks are exposed in the southeastern and northwestern portions of the area mapped, and extend through under the lavas of the Lassen Peak district from the Sierra Nevada to the Klamath Mountains of the Coast Range. The broad stretch of unaltered lavas about Lassen Peak does not contain any appreciable amount of precious metals, and may be wholly neglected by the prospector.

Among the auriferous slates seven formations have been distinguished, ranging in age from the Silurian to the Jurassic, inclusive. Of these the Cedar formation, of Triassic age, has been the most productive. By its disintegration it has furnished the gold for the placer mines of Indian Creek below Shoo Fly, of Soda Creek, Rush Creek, the north fork of Feather River and Dutch Hill. The Savercool mine, by the north fork of Feather River, is on this belt, and active prospecting is going on at a number of points. Numerous copper deposits have been discovered in the Pit River region.

Intermingled with the auriferous slates, there are eruptive rocks, such as diabase, porphyrite, peridotite and diorite, which have much to do in determining the distribution of certain classes of ore bodies. The areas of eruptive rocks have been outlined, and it has been found that the most promising prospects of that region are located near the borders of these eruptive masses. The ore deposits may be in the auriferous slates or the eruptive rock, but in either case they are not far from the contact.

Traces of coal have been discovered in the Chico and Ione formations, but no deposits of considerable value are yet known in the region of Lassen Peak. The Tuscan tuff has furnished some excellent material for chimneys, hearths and water coolers. The large deposit of diatom earth on Pit River, having a thickness of over 100 feet

and a length of several miles, is of economic importance for polishing, packing, making explosives and other purposes.

FOLIO 17, MARYSVILLE, CALIFORNIA, 1895.

This folio consists of 2 pages of text descriptive of the Marysville tract, signed by Waldemar Lindgren and H. W. Turner, geologists, and G. F. Becker, geologist in charge; a topographic map (scale 1:125,000) of the tract, a sheet showing the areal geology, another showing the economic geology and a third exhibiting structure sections.

The Marysville tract includes the territory between the meridians $121^{\circ}30'$ and 122° and the parallels 39° and $39^{\circ}30'$, and contains 925 square miles. The tract is located near the center of the Sacramento Valley. The larger part of it is occupied by the alluvial plains of the Sacramento and Feather rivers. The extreme northeastern corner includes the first rolling foot hills of the Sierra Nevada. In the center of the tract rises the isolated mountain group of the Marysville Buttes.

The alluvial lands consist of sands, clays and gravels, deposited by the shifting currents of the streams. The foot-hill region of the northeastern corner is principally occupied by the gravels of Pleistocene and Neocene age. The area composed of the bed-rock series of the Sierra Nevada is small and consists of diabase and porphyrite. The mountain group of the Marysville Buttes is an extinct volcano of probably late Neocene age, the internal structure of which is to a certain extent laid bare by erosion. The eruptive rocks of the buttes are andesites and rhyolites. In describing the structure of the group three parts may be distinguished: First, the central core of massive andesite and rhyolite; second, the upturned sedimentary rocks surrounding the massive core, evidently brought into their present position

by the force of the ascending lavas; the sediments are of Eocene and Neocene age; third, the external ring of tuffs and breccias. The feature of greatest interest in connection with the Marysville Buttes is doubtless the presence of upturned sediments around the central core.

The shore gravels in the northeastern corner contain some gold and have been washed superficially. Somewhat auriferous gravels are also found in the upturned sediments of the Marysville Buttes. Coal and natural gas have been found in small amounts in the Marysville Buttes.

A GLACIER IN THE MONTANA ROCKIES.

THE section of the Rocky Mountains lying between the Great Northern Railway and the international boundary has thus far been but little explored. Until the advent of the railway there was such difficulty in reaching these mountains that only an occasional prospector or trapper penetrated their fastness. As access has become easier it has been growingly evident that it is a region of remarkable scenic and geological interest. Thus far it has been reached largely from the eastern side, but this has been troublesome from the fact that skirting the eastern slope of the mountains is the great Blackfoot Indian reservation, over which it is impossible to travel without much annoyance.

Several glaciers have been known to exist in these mountains and two are located upon the military maps of the department of Dakota. The largest of these is known as the Grinnell glacier from Mr. George Bird Grinnell, who has made a number of expeditions into the region and has done more than anyone else to attract attention to it. The Grinnell glacier is not easily accessible and for some time efforts have been made to discover others which could be more easily reached by the ordinary tourist. About a year and a half ago Dr.

Lyman B. Sperry, of Bellvue, Ohio, became interested in the matter and determined to organize a party for exploration. In July last the party, consisting of Dr. Sperry; Mr. A. L. Sperry, of Owatouna, Minn.; Mr. E. R. Shepard, of Minneapolis, and the writer, with guides, pack animals and camp equipage, entered the mountains. I can best convey an idea of the region by following somewhat in detail the movements of the party.

The Great Northern road crosses the mountains about forty miles south of the international boundary, following on the western side of the divide the Middle Fork of the Flathead River. Twenty miles from the summit, at Two Medicine pass, is Belton station. Here there falls into the Fork a large and rapid mountain creek. It comes from McDonald Lake, three miles away in the mountains northward. From station to lake there is a mountain road over which a buckboard travels as often as tourists call for its service. The lake is already much resorted to, since its waters afford most excellent fishing and its shore unexcelled camping places. A small steamer makes regular trips over the fifteen miles of deeply blue water. The lake has a depth of twelve hundred or more feet in some parts and its surface is thirty-four hundred feet above sea level. The mountains along the sides of the lake are covered with pines to the summit. Near the northern end are several mountains of greater altitude, their summits rising above timber line and covered with great snow fields. The most prominent of these mountains have been named Mt. Lottie Stanton, Mt. Brown, Mt. Edwards and Mt. Sperry.

At the northern end of the lake several cabins have been erected and several packers and guides have established themselves to provide horses and other necessaries for travel. Our party, starting from this point, made its first essay into a small, lateral

valley discovered by a prospector sent out by Dr. Sperry a year ago. In June last Dr. Sperry penetrated the valley and found the avalanches falling frequently and such masses of snow upon the ground as to preclude any careful survey or any mountain climbing. The valley is called Avalanche Basin and is twelve miles from Lake McDonald, eight miles northward along McDonald Creek, thence four miles eastward to the main divide. The Basin is three miles long by one mile wide, much of its area filled with a delightful lake. Our attention was particularly drawn to this valley, in connection with our hunt for glaciers, because the lake had that peculiar milky appearance so characteristic of glacial water. In the valley we spent two weeks. A transit instrument had been packed in, and by means of it we measured carefully the heights of the surrounding mountains. The most prominent of them was found to be from twenty-eight hundred to five thousand feet above the surface of the lake, making the loftiest between nine and ten thousand feet above the sea. On every side the evidences of former glacial action on an immense scale were to be found. The strata, of gray and greenish shales and red slates for the most part, dip to the northwest. On the south side of the valley the exposed edges are scored and polished beautifully. Behind each 'sheep back' is a dazzling little pool of mountain water. To this series of pools we gave the name of Terrace Pools. Eastward from these pools is a slope which has been ploughed and over by the ancient glacier and is now yearly harrowed by the avalanches. We twice made the ascent of the mountain at this place, reaching a point over nine thousand feet above sea level. From this point, at the foot of a still higher and very precipitous mountain peak, looking northward can be seen numberless peaks of the main range, while westward is the very distinct secondary range which

accompanies the main range for more than sixty miles. On the northward and eastward slopes are many large snow fields which might be the heads of glaciers, but which give no satisfactory evidences of being such in a distant view. We also endeavored to find a trail to the summit at the eastern end of the basin. The view from the point mentioned above suggested strongly that on the northeastern slope might be found several small glaciers. It was, however, found impossible to reach the summit by any route which we were able to try. It may still prove that the glacial looking water of Avalanche Lake is not misleading. Our evidence regarding it is wholly negative. While it may prove impossible to reach any glacier of importance by way of this valley, it must continue to be both to tourist and geologist a place of fascinating interest, for nowhere, so far as I am aware, are glacial phenomena on such a scale so easily accessible.

Being thus disappointed in Avalanche Basin, our party determined to try its fortune further north. Recently some mining properties have been located at a point where the main range, after trending almost due north from Lake McDonald for about thirty miles, suddenly sweeps around to the westward. To secure access to these properties those interested have cut a very good trail from Lake McDonald to their camps. The trail follows for a large part of the distance McDonald Creek, which flows along the valley between the main and the secondary ranges. By this route our party took up its march. The lower part of the trail rises slowly, but near the end it becomes steeper, although nowhere so difficult as to make it troublesome riding even for unaccustomed horsemen. We made our final camp near a group of mines in which development and locating work was going on. The group is called the International Camp. Its altitude is sixty-five hundred

feet above the sea, and from it there is a wonderful mountain view, especially of the secondary range west and south. To the east there is a saddle of the main range some two thousand feet above the camp. To this saddle our attention was directed as affording access to the eastern side of the range, and our mining friends asserted that immediately over the divide a glacier was to be found. Accordingly the morning after our arrival we made the ascent, finding it not difficult and entirely practicable for saddle horses up to less than a thousand feet below the ridge and easily made passible for pack animals to the summit. We found the point where we crossed the divide to be 8,400 feet above sea level. Immediately on stepping down from the rocks on the eastern side of the range we were upon an immense snow field filling an amphitheater some four miles in diameter. While of greater extent than any which we had before visited it did not seem to be different, and we thought again that the glacier must be farther on. As we crossed the snow field to the east, there appeared running parallel with the curving wall of the amphitheater lines upon the surface whose significance we did not at first apprehend. Observation with the field glass soon indicated what closer examination afterward confirmed, that these were long crevasses in the ice. We then knew that we stood upon the upper snow fields of a glacier not of great size, but in many respects very typical. The crevasses first noted were found to be of varying width from one so narrow that the finger could scarcely be thrust into it to one some five feet across at its widest. In this we made soundings to the depth of forty feet, this being the length of all our available cord. From dropping stones into the crevasse we judged that it reached a depth of one hundred feet or more. Passing on to the eastern side of the amphitheater we ascended the rocky ridge which

formed its boundary. Then suddenly there burst upon us one of the most tremendous mountain scenes any of the party had ever had the good fortune to witness. Sheer down below was a cliff which repeated experiments with falling rocks showed to be more than sixteen hundred feet of perpendicular precipice. From the base of this cliff the talus sloped down sharply to the bottom of the valley no less than three thousand feet below. Across the valley in front of us towered a mountain ridge which we called the Bear's Teeth. It rose three thousand feet above us as the valley dropped below. Around the northern end of the ridge on which we stood swept the glacier narrowed into a true ice river. As it broke over the cliff to plunge into the valley it was fractured with crevasses of much greater size than those mentioned before. The largest was about twenty feet across and into it plunged one of the surface streams which came down the glacier. Below in the valley lay a succession of lakes. The first of so deep and dark a blue that without hesitation we called it Emerald Lake. The second, opposite the foot of the glacier, was of that peculiar milky whiteness thought to be always indicative of a glacier. For this Glacier Lake seemed the one appropriate name. The moraine at the foot of the glacier was evidently almost entirely ground moraine. There were very few large rocks lying in a mass of finely divided gray detritus. Across this rushed the stream which came from the foot of the glacier. Where the stream entered the lake the silt carried by it was borne out into the waters like the smoke from a cannon's mouth. In the time at our command it was not possible to descend the mountain to the level of the lakes, but they seemed to be of great depth with sandy and shingly beaches and closely surrounded on all sides by the forests of fir and hemlock.

From the point of our first observations

of the valley we proceeded northward, crossing the ice river at the point where it left the main amphitheater to descend into the valley. At each point of vantage photographs were taken by Mr. Shepard. The writer and one guide descended along the northern margin of the ice about two thousand feet, finding some glacial scorings of interest, and under one edge several caves of considerable size. These were not of sufficient height to stand upright in, but extended for forty or fifty feet under the ice. The roof of clear blue ice was carved into low arches through which the light came, subdued into a wonderfully soft and grateful tone after the glare of the snow fields.

From this vicinity we had a most satisfactory view of the valley. The first portion of it passing athwart the foot of the glacier had a direction almost due north and south. Turning then to the east, it extended some eight or ten miles, flanked on either side by lofty mountains. Two of these particularly attracted attention. The dip of the strata in all this region, so far as observed, is toward the northwest. They consist of gray and yellowish shales and brilliant red slates. The two mountains in question have at their summits the outcroppings of two strata of red slates. This flaming head gear suggested the names North and South Red Mountain. Extending toward them were two more of the valley lakes, one of which, from its position, we called Centre Lake, and the other, six miles in length by three-fourths of a mile wide, seemed to deserve the name Long Lake. Still beyond Long Lake, its farther shore hidden by the foot of South Red Mountain, the fifth lake gleamed, a vivid contrast to the vermilion peaks on either hand. For the valley, as a whole, I have thus far sought vainly to learn the Indian equivalent for 'The Valley of the Five Lakes,' hoping that it might be something which would be musical and usable. From

other sources of information it seems that probably there are not five, but seven lakes in the valley. It may well, therefore, be nameless until more fully explored. It should be remarked in passing, that beginning with South Red Mountain, and extending northward, is a geological section of remarkable extent. No less than five miles in thickness of strata is presented before the observer with diagrammatic clearness.

Leaving the glacier we passed northward over a rocky upland where the 'sheep backs' testified of former glacial work on a tremendous scale. This led us into another amphitheater of smaller dimensions than the one occupied by the snow fields of the glacier. In this basin, eight thousand feet above sea level, a small lake met our sight. The mountain wall on its western shore was covered by what may be called glacial snow fields. These fields were of sufficient extent to be partially compacted into ice. As these ice masses moved down into the lake great cakes were broken off after the manner of icebergs where glaciers descend into the sea. This lake we called Summit Lake.

The outlet of this lake dropped by a series of cascades into a deep valley on whose far side rose a mountain of such form that Pyramid Mountain must be its name.

Returning from Summit Lake we crossed the snow fields, again traversing nearly its greatest diameter. Noting the time required gave a basis for estimating this diameter at about three and one-half miles. We also examined the lateral moraine, finding it to consist of basaltic fragments mainly of large size. There appeared to be considerable mineral bearing material in this mass. A surface moraine of yellow slate was of considerable interest. An enormous mass of rock had evidently fallen upon the surface of the ice from the overhanging mountain. Through and under it were a number of water-worn tunnels of curious

form, which I did not have time to examine with care.

Some crude observations were made as to rate of movement. Between two days there seemed to be a movement of the center of the mass of about two inches. This is not reliable, however, since conditions for accuracy could not be supplied.

To the peaks north and south of the ice field we gave the names of Mt. Blanchard and Mt. Cunningham, in honor of the guides who had served us during the expedition.

At some future time I hope to return to this region and extend these explorations further. In the meantime I commend it to those who wish to study mountain forms or glaciers and glaciation. There is an abundant and very interesting fauna and flora to be investigated, and on every side the majesty and glory of one of the noblest mountain ranges. In accessibility, in varied interest, in all which may attract either the lover of splendid scenery or the devotee of scientific exploration, no American or foreign locality is more enticing.

L. W. CHANEY, JR.

CARLETON COLLEGE, NORTHFIELD, MINN.

THE HUXLEY MEMORIAL.

THE first meeting of the general committee formed for the purpose of establishing a memorial to Huxley was held in the Museum of Practical Geology, London, on the afternoon of November 27th. We take from the detailed report in *The Times* the following particulars:

The chair was occupied by the Duke of Devonshire, who opened the proceedings by referring to the official side of Huxley's career, stating that he did this as the official head of the Science and Art Department. Prof. Huxley immediately after leaving the Navy, in which he commenced his career, succeeded, in 1854, Prof. Forbes as Lecturer on Natural History in the Central School of Science in Jermyn-street.

This school subsequently became the Royal School of Mines. It was transferred to South Kensington in 1881, and there merged in the Royal College of Science. Prof. Huxley was the first Dean of the College, and on his retirement from the public service, in 1885, he was requested by the heads of the Department to retain the office in an honorary capacity, and that he did to the day of his death, attending the meetings of the Council and giving assistance in other ways. He was also honorary professor of biology in the College and retained a general charge of the biological section. While professor at the College he developed his system of biological teaching, which has had so marked an influence on biological teaching in all parts of the world. On his retirement, in 1885, he presented to the College his large and valuable collection of books on natural history. The room which he occupied was, by the authority of the Lords of the Committee of Council on Education, devoted to a Huxley biological laboratory for research, and it is in constant use by advanced students of biology. A scholarship has been endowed in connection with the College, and the history of the endowment may be of some interest. Prof. Huxley on one occasion met in society Miss Marshall, daughter of Mr. Matthew Marshall, for many years chief cashier of the Bank of England, and in consequence of her conversation with Prof. Huxley on that occasion Miss Marshall left to the department a large number of books and other instruments, and in addition a bequest of £1,000, from the proceeds of which a scholarship has been endowed. Prof. Huxley was for more than 40 years intimately connected with the Science and Art Department. The museum in Jermyn-street, in which we are met to-day, is a section of that department, and both in the lecture theatre and in the class-rooms upstairs Prof. Huxley for

many years delivered his lectures. It was almost my first duty—and I need not say my painful duty—on becoming President of the Council to address, on behalf of the Committee of Council on Education, a letter of condolence to Mrs. Huxley, in which the committee placed on record its high appreciation of the services to science and art rendered by Prof. Huxley, in the capacities to which I have referred and on the many inquiries by Royal Commission in which he had taken part.

Prof. M. Foster said that the history of the movement for a memorial to Prof. Huxley, he thought, would be of interest. The movement was initiated by a few friends of Prof. Huxley, who met at the Royal Society, and a provisional committee of representative men was formed. The invitations which they issued to a large number of influential persons to form a general committee were cordially accepted, and the Prince of Wales consented to join the committee and undertake the duties of honorary president. At that time it was too late in the summer to take active steps; so the meeting of the general committee was postponed till the present date. The provisional committee had given much time to the consideration of the form which the proposed memorial should take, but, of course, the decision would rest with the general committee.

Lord Kelvin then moved the following resolution:

“That it is desirable to establish a memorial to the late Right Hon. T. H. Huxley.” He said that, as an original investigator in biology, Huxley had, by his life-long perseverance in work for the increase of knowledge, left to the world a monument more enduring than any bronze or marble in which his survivors might give material expression to their gratitude. Of his originality Huxley gave early proof. His first writings were not done in a

scholastic manner, but were inspired by the innate fire and determined purpose of the man, and were the beginning of a long series of memoirs which made Huxley's name famous throughout the scientific world, and won for him early recognition as one of the first biological investigators of the day. In comparative anatomy Huxley's work was of immense value, and he almost created a new era in biological science by the great advances which he made in the new morphology. The instruction in morphology and general biology which students of Huxley's day could not obtain in any medical school or university was now regularly and systematically given, to the great advantage of medical science, of science in general, and of those who wished to understand the grandeur and beauty of nature, and what lay under it. Huxley also entered upon the subject of geology and paleontology, and there he had left results of an enduring character. His important contributions to the great and newly-developed science of evolution were well known, and only needed to be mentioned to indicate how much science owed to Huxley: But he was not a man who was merely a specialist, content to work out his special subject in the complete and thorough manner which characterized all his work. From the first he had a mind which must extend into philosophic thought; his moral lessons from biological work extended even into the field of politics. His contributions to thought in respect of theology were themselves such as would put Huxley's name and fame in a very high position indeed. He sacrificed his ease, his health and his time primarily for the advancement of science, but ultimately for the object which he felt to be even greater than the advancement of science—the promotion of the moral and material welfare of mankind. And that being the case, who could deserve a monument better than Huxley?

Mr. A. J. Balfour, in seconding the resolution, referred more especially to Huxley's contributions to the doctrine of evolution. He said that in the critical period of scientific history which followed the publication of the 'Origin of Species,' in 1857, the man who did more than any other man, perhaps, to stimulate public interest in the subject, to bring into line all the younger scientific thinkers of the day, to inspire them with his ardor, with his beliefs, and with his convictions, was probably Huxley. That is no small title to fame. If it be the fact, as I think it is, that it is now the common property of all educated men to look on this material world in which we live from the evolutionary standpoint, if that is a matter of common knowledge, belief and conviction, as I think it is, we owe that, not to the great original investigators who started the theory, but to those who, like Professor Huxley, did so much by their scientific discoveries to support it, and even more by their preaching and example to spread it among all classes of their fellow-countrymen. There were other questions never far absent from the mind of Prof. Huxley, as any one who knows his work will admit, on which he has left few positive results, and concerning which differences of opinion exist. But there ought to be no difference of opinion as to that great claim on our consideration; and that, even if it stood alone, dissociated from his literary and strictly scientific work, would, in my judgment, be quite sufficient justification for this meeting, and for us to use every exertion to carry into effect the resolution which it is my honor and duty to second.

Lord Playfair, in supporting the resolution, said that it had been his privilege to be associated with Prof. Huxley in many of his labors as a public man. The present position of technical education owed very much to the advocacy and scientific labors

of Prof. Huxley; and up to the time of his last illness he was actively interested in the establishment of scientific scholarships in almost every college in the United Kingdom, and of the Indian Empire and the colonies. One whole autumn he had spent on a gunboat with Prof. Huxley, in connection with the Royal Commission on the Fisheries of the Coast, and his labors, assistance and knowledge in that inquiry were most valuable. He did not wish to overrate Prof. Huxley's labors as a public man in comparison with his scientific work. Discoveries in abstract science were of far greater service to humanity than the labors performed for one particular generation. But public work had done much to make Huxley's name loved by the people; and it was right to ask the people, for whom in his generation he had done so much, to join in making the memorial worthy of him.

Sir Joseph Hooker moved: "That the memorial do take the form of a statue to be placed in the Museum of Natural History, and a medal in connection with the Royal College of Science; and that the surplus be devoted to the furtherance of biological science, in some manner to be hereafter determined by the committee, dependent upon the amount collected." He said that he and Prof. Huxley entered the public service together as volunteers. The choice lay between them for the appointment to the Rattlesnake, and when Huxley returned from that cruise a friendship sprang up between them that had lasted for 40 years; and he owed his success in scientific life to the advice, stimulus and example of Huxley. He was sorry to say that Huxley's services to science were more appreciated abroad than even in this country. In the committee lists, which included more than 700 names, the foreign acceptances were more numerous than those at home. He hoped this state of things would speedily be remedied. The provisional committee

had thought of publishing, in a series, Huxley's scientific papers; but that was no longer necessary, as Messrs. Macmillan had written that they were prepared at their own risk to publish Huxley's papers in a collected, memorial form, provided that the committee would appoint some one to supervise the series. Messrs. Macmillan had promised to defray the cost of editing.

Mr. Leslie Stephen, in seconding the resolution, said that a high sense of personal gratitude to Huxley moved him to take part in this meeting. In a friendship of nearly 40 years Huxley had shown to him exceptional kindness on more than one occasion. Huxley was a man not only to be honored for his intellectual power, but to be loved for his masculine, affectionate nature. Lately he had read through Huxley's collected works, and he was convinced that when the history of this time came to be written, Huxley would find a place, not only among the leaders of the most characteristic scientific movement of the day, but also as one of the very first writers of English.

Mr. Alma-Tadema moved the following resolution:

"That the persons named in the list which has been circulated do form a general committee, and that the following 20 persons be selected to form an executive, with power to elect its own chairman, and to add to the number of the general committee: Sir J. Lister, Prof. M. Foster, Lord Rayleigh, Prof. E. Frankland, Sir J. Evans, Sir W. Besant, Sir J. Donnelly, Sir J. Fyfe, Sir W. H. Flower, Sir A. Geikie, Sir J. Hooker, Prof. E. Ray Lankester, Prof. J. N. Lockyer, Mr. Briton Riviere, Dr. P. L. Sclater, Sir H. Thompson, Mr. Spencer Walpole, Lord Shand, Sir John Lubbock and Prof. G. B. Howes."

Prof. G. B. Howes said that the sum already received in subscriptions to the memorial was £213, while £344 more was promised, making a total of £557.

CURRENT NOTES ON ANTHROPOLOGY (XV.).

ANCIENT MEXICAN MOSAIC WORK.

SLIGHT attempts at inlaying with shells, mica and the like, are not unfamiliar in the art of the northern native tribes of America; but nowhere else on the continent was the technique so developed as in Mexico. This is beautifully illustrated in an excellent monograph by Mr. Charles H. Read, of the British Museum, in 'Archæologia' (Vol. LIV.), on 'An Ancient Mexican Head-piece coated with Mosaic.' His scope is much more extensive than his title. Not only does he describe accurately the piece referred to, and give a large colored engraving of it, but he deals with all the known and accessible relics of the kind, eight in number, figuring and explaining them minutely. As it has long been doubted whether true turquoise is to be found in Mexico, Mr. Read adds a note from Mr. Rudder, of the Museum of Practical Geology, in which that question is answered positively in the affirmative. This monograph should be consulted by all who would understand the real advances made by the Nahuas and their neighbors in the fine arts.

EUSKUARIAN ETHNOLOGY.

Few ethnic problems are more complicated than that of the Euskuarians, or Basques, of the Pyrenees.

The lexicon of their language is practically Aryan, while its grammar is as un-Aryan as could well be imagined; physically they differ from their neighbors in well-defined traits, and also between each other in a not less positive degree.

A most valuable contribution on the somatologic side has appeared recently in *L'Anthropologie* by Dr. R. Collignon, surgeon-major in the French army and a distinguished anthropologist. He succeeds in clearing away the obscurities arising from the misapprehensions of Broca and other older observers, and establishes the real

Basque type. His conclusion is, "that the true physical traits of the Basques attach them indisputably to the great Hamitic branch of the White Race, to that represented by the Berbers and ancient Egyptians; and not at all, as some have argued, to the Esthonians or Finns. The Basque affinities are North African or European, certainly not Asiatic."

This conclusion, thus announced by one of the highest authorities, is substantially that expressed in my 'Races and Peoples,' published in 1890 (page 142).

MAYAN HIEROGLYPHICAL STUDIES.

It is pleasant to note the amount of attention now shown to the decipherment of the hieroglyphical writings of the ancient Mayas. A brief notice of some late papers on this branch may be welcome.

In July Dr. E. Förstemann issued the fifth part of his researches entitled 'Zur Entzifferung der Mayahandschriften.' It is devoted to a definition of the astronomical and ritual years of the Mayas, based largely on analyses of the Dresden manuscript.

An article by Dr. E. Seler, in *Globus*, Bd. 68, No. 3, is upon the significance of the Maya calendar for the historical chronology of Yucatan. It is characterized by that keen-sighted erudition which Dr. Seler possesses, and is a contribution of great merit.

The same writer, in the *Verhand. der Berliner Anthropol. Gesell.* has discussed the bat-god of the Mayas and also explained the symbols and glyphs on a vase found at Chamá by Mr. Dieseldorff.

The American Anthropologist for July contains a careful article by Mr. J. Walter Fewkes on "The god 'D' in the Codex Cortesiânus." He differs from the conclusions I have expressed in my 'Primer of Mayan Hieroglyphics,' and the question is probably not closed by either of us.

D. G. BRINTON.

UNIVERSITY OF PENNSYLVANIA.

SCIENTIFIC NOTES AND NEWS.

LETTER OF THE LOCAL COMMITTEE OF THE
SCIENTIFIC SOCIETIES.

Geological Society of America, American Society of Naturalists, American Physiological Society, American Morphological Society, Association of American Anatomists, American Psychological Association.

COMMITTEE:

PROF. E. D. COPE, *Chairman*, 2102 Pine Street (Am. Morph. Soc.).

DR. HOBACE JAYNE, *Treasurer*, 19th and Chestnut Streets (Am. Soc. Nat.).

DR. HARRISON ALLEN, 1933 Chestnut Street (Assoc. Am. Anat.).

DR. EDW. T. REICHERT, Univ. of Pa. (Am. Phys. Soc.).

DR. W. R. NEWBOLD, College Hall, Univ. of Pa. (Am. Psy. Assoc.).

DR. PERSIFOR FRAZER, *Secretary*, 1042 Drexel Building (Geol. Soc. Am.).

PHILADELPHIA, November, 1895.

DEAR SIR: Every member of each of the above Societies will be notified by the appropriate Secretary of the date of meeting of his Society in Philadelphia. The meetings will be held in the University of Pennsylvania's grounds, either in the College Hall or in the building of the Department of Medicine.

The headquarters for all visiting members will be the Hotel *Lafayette*, situated on Broad street below Chestnut, a very short distance from the terminal stations of the Pennsylvania and Reading railroads. Its rates are \$1.00 and upward per day on the European plan, \$3.00 and upward on the American plan. The *Bellevue*, *Stenton* and *Stratford*, \$2.00 to \$5.00 (European plan); the *Metropole*, \$1.50 and upward (European plan), and the *Colonnade*, \$3.50 (American plan), are near by. The *Continental*, \$1.00 and upward (European plan) to those presenting this circular, and \$2.25 and upward (American plan), and the *Girard*, also \$2.25 (American plan), are both at Ninth and Chestnut streets. The *Bingham* House, at Eleventh and Market, opposite the Reading terminal station, charges \$2.50 (American plan). All these hotels are either directly on or not more than a block from the trolley cars which go directly out to

the University grounds on Walnut and Market streets and return on Chestnut and Market. The time required from the hotels to the University grounds should be less than 25 minutes.

The Trunk Line Association has granted the usual reduction of one and one-third fares for the round trip to those attending the meeting, and provided with certificates to be obtained from the ticket agents, who sell tickets from the points of departure to Philadelphia at one full fare each. These tickets must state that the object of making the journey is to attend the meeting of the _____ Society at Philadelphia. The certificates must be viséd by a representative of the local committee and of the Trunk Line Association, at the College Hall on December 27 or 28. The Secretary of the local committee has given his personal pledge to redeem at full fare any such tickets that may subsequently be found in the possession of 'scalpers.'

In order to facilitate the work, members are requested, as soon as possible after arrival, to register their names and the Society to which they each belong with a clerk who will be in attendance in College Hall.

A subscription dinner of the members of all the Societies, at \$2.00 per plate, will be given at the Hotel *Lafayette*, on the evening of Friday, December 27, 1895. You are requested to send word if you desire to participate in this dinner, and to pay the sum of \$2.00 to the Treasurer, Dr. Jayne, or his designated agent in College Hall, not later than noon on December 27, for each place which you wish reserved.

On Thursday evening, December 26, from 8 to 9 o'clock, Prof. Wm. B. Scott, of Princeton, will deliver an illustrated lecture before the visitors at the Hall of the Academy of Natural Sciences, 19th and Race streets, on 'the history of the lacustrine formations of North America and their mammalian fossils,' after which Dr. Horace Jayne will receive the members of the visiting Societies at his house, 19th and Chestnut streets.

DR. PERSIFOR FRAZER,
Sec'y Local Committee,
1042 Drexel Building, Philadelphia.

THE METRIC SYSTEM IN GREAT BRITAIN.

A DEPUTATION from chambers of commerce and other bodies waited on Mr. Balfour, First Lord of the Treasury, on November 20th, urging that the government carry out during the next session of Parliament the recommendations made by a committee of the House: That the metric system of weights and measures be at once legalized for all purposes; that after a lapse of two years the metrical system be rendered compulsory by Act of Parliament; that the metrical system of weights and measures be taught in all public elementary schools as a necessary and integral part of arithmetic, and that decimals be introduced at an earlier period of the school curriculum than is the case at present. Sir A. Rollet, who introduced the deputation, said that of sixty-eight chambers of commerce all but one favored the memorial. The present system was obsolete and disastrous to British trade, leaving it in a position of isolation. No proposal was made in regard to the coinage at present. Speeches were made by others, including Sir Samuel Montague, who said that if England adopted the metrical system the United States would also do so. Mr. Balfour in his reply expressed complete concurrence with the first and third propositions. He, however, thought that there would be very great difficulty in compelling every class in the community suddenly to alter its habitual practice in the weights and measures in which it deals. Mr. Balfour concluded by saying that while he looked forward to the time when the change could be made, he would like private enterprise to show that this can be done without inconvenience, and that it carries with it all the benefits which he, in common with them, attached to the metric system, and which it is absolutely impossible to associate with the arbitrary, perverse and utterly irrational system in which they had the misfortune to grow up. It follows from Mr. Balfour's address that that metric system will be at once legalized and instruction in it required in all schools, but that its general use will not be made compulsory at present.

PRESERVATION OF FORESTS.

THE report of the Hon. Hoke Smith, Secre-

tary of the Interior, pays special attention to irrigation and preservation of the forest. Mr. Smith says that there have been reserved from settlement, under the act of March 3, 1891, 17,000,000 acres of land as forest reserves. The object of these reservations is to preserve the forests themselves for future use, and through the preservation of the forests to protect and reserve the supply of water, so that it may be stored and utilized for irrigation. These forest reserves protect the head waters of many of the streams used for irrigation. If the deprivations upon them continue at the present rate, they will, in a few years, be entirely denuded of their timber, and will thus leave the lands surrounding the head waters of irrigating streams subject to the direct rays of the sun, causing waste through floods at an early season of the year and the loss of benefit to the agricultural lands when the water is needed later. If, however, the timber lands are protected and kept intact, the melting of the snow will be gradual, floods will be prevented, and a flow will be maintained until late in the spring. The force of the General Land Office is, however, inadequate to protect the general reservations and the permits for cutting timber authorized by law have been much abused. Mr. Smith recommends the appointment of special agents to protect the forests against fire and depredation and that a rational system of timber cutting under competent supervision be substituted for the present system of timber permits. Mr. Smith thinks that it would be desirable to obtain, under the provisions of the constitution of the National Academy of Sciences, a report from that body upon the general subject of forestry administration in this country, particularly if it were possible for them to employ experts to collect statistical information as to the area, location and character of the wooded lands belonging to the United States.

FAST TRAINS IN GREAT BRITAIN AND THE UNITED STATES.

THE following are the tabulated figures of two fast runs in this country and of the record-breaking run, to date, in Great Britain, as made up by the Lake Shore Railway, which holds the record for the world. The second table is

published by the *Railway Master Mechanic* in its issue for November.

WORLD'S RECORD.

| | Lake Shore & Mich. South. | N.Y. Central & H. R. R. | West Coast Route. |
|--|---------------------------|-------------------------|-------------------|
| Date | Oct. 24, 1895 | Sept. 11, 1895 | Aug. 22-23, '95 |
| No. of cars | 3 | 4 | 3 |
| Weight of cars | 304,500 | 358,310 lbs. | 150,050 |
| Starting point | Chicago | New York | London |
| Finish | B'falo Creek | East Buffalo | Aberdeen |
| Total distance in miles | 510.1 | 436.32 | 589.75 |
| Total time in minutes and seconds | 481 m. 7 s. | 411 m. 56 s. | 512 m. |
| Average speed in miles per hour | 63.614 | 62.55 | 63.25 |
| Total time in motion | 470 m. 20 s. | 407 m. 41 s. | 505 m. |
| Average speed deducting stops | 65.07 | 64.22 | 64.12 |
| Length of division on which fastest average speed was made | 86 | 145.6 | 141.25 |
| Average speed on said division | 72.92 | 65.75 | 67.50 |

DETAILS.—L. S. & M. S.

| | | |
|-------------------------------------|--------|----------------|
| 1 mile was made at the rate of..... | 92.3 | miles per hour |
| 8 consecutive miles " " | 85.44 | " " " |
| 83 " " " " | 80.6 | " " " |
| 85 " " " " | 72.92 | " " " |
| 181.5 " " " (including stops) | 68.67 | " " " |
| 181.5 " " " (deducting stops) | 69.67 | " " " |
| 289.3 " " " (including stops) | 65.14 | " " " |
| 289.3 " " " (deducting stops) | 66.68 | " " " |
| 422.7 " " " (including stops) | 64.45 | " " " |
| 422.7 " " " (deducting stops) | 65.89 | " " " |
| 510.1 " " " (including stops) | 63.614 | " " " |
| 510.1 " " " (deducting stops) | 65.073 | " " " |

In the last trial the work was done so easily, and the train moved so smoothly, that it is thought that the figures may be considerably improved upon. The English run included but two stops, the New York Central run three, and the Lake Shore five. The latter employed engines with steam cylinders 17 by 24 inches; the Central used 10 by 24, and the British engines were all larger. The Central train weighed over 250 tons, including engine; and the English, unusually light, even for English trains, weighed less than one-half as much. The latter could not carry passengers enough to pay costs; the former could carry 218 passengers. Neither, however, carried an ordinary load. The American line holds the record for a single, special, fast run over a long route, as well as that for a single mile—over 100 miles an hour by engine '999'—while the English, 'West Coast,' road has the fastest regularly scheduled long-distance train.

GENERAL.

THE annual meeting of the American Mathematical Society will be held at Columbia College, New York, on Friday afternoon, December 27th. The following nominations reported by the Council will be acted upon: President, Dr. G. W. Hill; Vice-President, Prof. Hubert A. Newton; Secretary, Prof. F. N. Cole; Treasurer, Prof. R. S. Woodward; Librarian, Prof. Pomeroy Ladue; Committee of Publication, Prof. Thomas S. Fiske, Prof. Alexander Ziwet and Prof. Frank Morley; Members of Council to serve until December, 1898, Prof. E. W. Hyde, Prof. W. Woolsey Johnson and Prof. B. O. Peirce. The President, Dr. G. W. Hill, will deliver an address at this meeting entitled 'Some Remarks on the Progress of Celestial Mechanics since the Middle of the Century.' Further information may be obtained from the Secretary, Prof. Thomas S. Fiske, Columbia College.

THE American Physiological Society will hold its eighth annual meeting in Philadelphia, Pa., on Friday and Saturday, December 27th and 28th, 1895. The sessions will be held at the University of Pennsylvania and at Jefferson Medical College. A Smoke-talk will be held upon the evening of Thursday, December 26th. The headquarters of the Society will be at the Lafayette Hotel, Broad street, near Chestnut street. Members of the Society will please inform the Secretary, Prof. Frederic S. Lee, Columbia College, at their earliest convenience whether they intend to be present at the meeting and what communications they desire to make. Those who will require apparatus or other necessities for the making of demonstrations will please communicate with Dr. E. T. Reichert, University of Pennsylvania.

THE American Psychological Association will meet at the University of Pennsylvania, on Friday, December 27th, at 10 A. M., and will continue in session through Saturday afternoon. Members should notice the information regarding local arrangements and railroad rates given in the circular issued by the local committee. On Saturday morning at 10 o'clock there will be a discussion on 'Consciousness and Evolution,' in which Profs. James, Cope, Baldwin and Dewey are expected to take part.

A STATUE in honor of Pasteur will be erected at Melun, near Fontainebleau, to commemorate his experiments in vaccinating sheep suffering from anthrax, which were first made in that district.

THE great Bruce photographic telescope having been tested at the Harvard Observatory will shortly be forwarded to the branch of the observatory in Arequipa, Peru. It will be taken by a steamship from New York to Molendo, whence it must be transported a distance of about 75 miles by rail and 3 miles by road, which latter causes the most serious difficulties. It is proposed to undertake systematic series of photographs of the heavens, which, owing to the great power of the instrument and its favorable position in the southern hemisphere, will undoubtedly yield results of much scientific importance.

DURING the month of December the presidents of the Washington Scientific Societies deliver the annual addresses which are as follows: The Philosophical Society, 'Alaska as it was and is, 1865-95,' W. H. Dall; The Geological Society, 'The Origin of Hypotheses,' G. K. Gilbert; The Biological Society, 'The Practical Results of Bacteriological Researches,' George M. Sternberg; The Entomological Society, 'On the Phylogeny of Hymenoptera,' William H. Ashmead.

It is reported that Prof. Dyche, of Kansas University has practically decided to make another trip to the Arctic Ocean, having received an offer of assistance from a source which he declines to name. His plan is to follow the west coast of Greenland, and then attempt to reach the pole by sledge or boat.

DR. EUGENE DUBOIS exhibited before the Anthropological Society of London on November 25th the remains which he has named *Pithecanthropus erectus*. In the discussion which followed, Sir W. H. Flower said that the fragments were so few that the essential point of difference between the human and the anthropoid forms could not with certainty be defined, but it showed more tendencies to the man side than any other remains he had ever seen.

MR. ROBERT T. HILL, Geologist U. S. Geological Survey, will deliver, in the Catholic Uni-

versity of Washington, seven lectures on General Geology, illustrated by the lecturer's researches in the United States, Mexico and Central America. The subjects are as follows:

December 5th.—'Modern Objects and Methods of Geologic Research.'

December 12th.—'Origin of Topographic Form.'

December 19th.—'Migrations of Land and Sea, as Exemplified in the Geologic History of the Gulf of Mexico.'

January 9th.—'The Mountain Systems of America.'

January 16th.—'The Great Plains and Basins of the Western Hemisphere.'

January 23d.—'The Relation of Geology to Civilization.'

January 30th.—'Future of Geologic Research in the Americas.'

It is stated that Pasteur's will reads as follows: "This is my testament. I leave to my wife all that the law allows me. May my children never forsake the path of duty, and always cherish for their mother the tenderness she so richly merits. L. Pasteur."

DR. D. G. BRINTON and Dr. William Pepper have been nominated for the vacancy of vice-president of the American Philosophical Society caused by the recent death of Dr. W. S. W. Ruschenberger. Dr. Persifer Frazer and Mr. Patterson DuBois have been nominated for the secretaryship, vacant through the death of Henry Phillips, Jr. The elections take place in January and are exciting much interest in members of the Society.

THE Columbia University Press is shortly to publish an 'Atlas of Nerve Cells,' by Prof. M. Allen Starr, professor of diseases of the mind and nervous system in the College of Physicians and Surgeons. The illustrations were prepared with the assistance of Dr. O. S. Strong and Dr. Edward Leaming.

THE New York *Evening Post* states that the Perrine comet has been observed at the Yale observatory, and an attempt to photograph it was unsuccessful. It was rapidly approaching the sun with slight signs, if any, of a nucleus, appearing as about a star of the fifth magnitude, distinctly visible through an opera glass and almost visible to the naked eye. Since then the brightness of the moon has interfered with

observations, and they will not be resumed for some time.

A CABLE despatch from Naples states that Mount Vesuvius is in a state of eruption. Three distinct torrents of lava are flowing from Atrio del Cavallo, burning chestnut groves along their path and falling into the Vetrana precipice, between Monte Somma and Colline del Salvatore.

MR. HENRY SEEBOHM, the well-known British ornithologist, died in London, November 26th. He was an honorary member of the American Ornithologists' Union.

THE Sixth International Congress of Otolology will be held in London, in 1899.

THE First Lord of the English Admiralty does not wish to receive a deputation at the present time on the subject of the renewal of Antarctic exploration under Government auspices; the reason being that all the resources of the Navy are at present required to place the English Fleet in a state of efficiency. Mr. Goschen expresses himself, however, as in sympathy with Antarctic exploration. A meeting of the committee that has been taking the lead in the movement will be held in a few days, and it is possible that they may decide to make an effort to interest the nation so far as to lead to a subscription sufficient to send out an expedition prepared to do two or three years' continuous work.

ACCORDING to *The Lancet* the foundation stone of a Museum of Anatomy and Surgery has been laid in St. Petersburg. The construction of such a museum was suggested by Prof. Ratimof, who is now President of the Pirogoff Chirurgical Society, and it is to be called the Pirogoff Museum. The scheme was well seconded; the Government provided 30,000 roubles towards the purchase and reconstruction of a building to contain the museum, and a sum of 60,000 roubles bequeathed to the Society by the late Countess Musin-Pushkin, to be expended on some memorial to the great Russian surgeon, has been put aside as an endowment of the new museum. The Society has purchased a building, used as a Government store since the time of the Empress Anna, appropriately situated on the banks of the Neva not far from the Army

Medical Academy and the large military hospital named after Sir James Wylie. The museum will be arranged on the lines of the Hunter collection in Lincoln's-inn-fields, London, and that of Dupuytren in Paris.

A RECENT return shows that during the year 1894 the cost of alcoholic drink consumed per head in England, Scotland and Ireland was respectively £3 17s. 4d., £3 1s., and £2 2s. 8d.

THE following results of experiments relating to the growth of trees at different times of the day have been sent to *Knowledge* by Mr. E. H. Thompson, the Government entomologist of Tasmania. Measurements were taken as far as possible every three hours, with the following results:

| | |
|------------------------------|-------------------------|
| From 6 a. m. to 9 a. m. | 8½ per cent. of growth. |
| “ 9 a. m. to noon..... | 1½ “ “ |
| “ noon to 3 p. m. | No growth. |
| “ 3 p. m. to 6 p. m. | “ “ |
| “ 6 p. m. to 9 p. m. | 1½ per cent. of growth. |
| “ 9 p. m. to 12 p. m..... | 3½ “ “ |
| “ 12 p. m. to 6 a. m..... | 85 “ “ |

The greatest growths in twenty-four hours were banksia rose, six and a-half inches; geranium, five and three-quarter inches; wattle, four and one-third inches; apple, two and a-quarter inches; pear, one and a-third inches.

ON November 1st a laboratory for study and research was opened in connection with the school of physical and industrial chemistry at 42 Rue Lhormond, Paris. By paying a fixed sum monthly to the city, anyone desiring to work in this laboratory will have all its facilities at his disposal.

THE publishers of *Knowledge* announce that the first colored astronomical plate ever issued in the magazine will appear in the January number. This will take the form of a colored drawing of Jupiter, which has been executed by Mr. N. E. Green, and reproduced by a special process. Amongst the special features for the new year there will be a paper on 'Scientific Geography in England,' by Dr. H. R. Mill, of the Royal Geographical Society, and the following series of illustrated articles: Mr. Vaughan Cornish, M. Sc., on 'Waves;' Mr. Theo. G. Pinches, on 'Akkadian and Babylonian An-

tiquities;' Mr. R. Lydekker, on 'Fur-Bearing Animals;' Mr. H. B. Walters, on 'Greek Art;' Mr. J. Pentland Smith, Mr. Botting Hemsley and other well-known writers, on 'Botany;' and Mr. G. F. Hill, on 'English and Italian Medals and Coins.'

UNIVERSITY AND EDUCATIONAL NEWS.

THE BUILDING FOR PHYSICS AT THE UNIVERSITY OF KANSAS.

FRIDAY, November 22d, a building was dedicated to the work in physics and electrical engineering. This department at the Kansas institution is in charge of Prof. L. I. Blake, who has been attracting attention in late years by his experiments in sea telephoning and fog signalling. That Kansas should devote a building to the study of the most modern and the most interesting of practical sciences is but a sign of the spread of greater interest in knowledge, and the appreciation of the good to be derived from the laboratory. The new building, which has been in process of construction for two years, has been erected at the expense of the State, costing \$60,000. The walls are of Berea sandstone, and the inner furnishings of ash. As little iron as possible was used in the construction of the building, the water pipes being of brass and the plumbing fittings of copper. The heating is by the Sturtevant system, all conduit pipes being tiling. An elevator for freight runs the entire height of the building, four stories. At each landing is a room, which is the repair room and workshop for that floor. Leading directly from each of these workshops is a chemical kitchen. The basement floor contains a large general laboratory and four private research rooms. On this floor are the battery room and the room for testing instruments. On the first or main floor are the office of the assistant professor, a small lecture room, the department library and reading room, a general laboratory and two rooms for private research. The second floor includes the office of the head of the department, a small lecture room, two special research rooms, and a large department lecture room. The latter room has an inclined floor, and is fitted with a lecture table provided with all

connections necessary for the demonstration of lecture experiments. Adjoining this lecture room and opening into it is the apparatus room, where are kept the various instruments used in the laboratories and for the illustration of lectures. Each room of the building is provided with wires, carrying currents from the dynamos located in the machine shops. All wires enter the building in the basement and are carried to a 'well' which runs from basement to roof, and this 'well' is provided with switchboards at each floor and all wires run in it.

The principal address at the dedication exercises was delivered by Professor Albert A. Michelson, of the department of Physics of the University of Chicago. The subject taken for the address was 'Some Objects and Methods of Physical Research.' After the formal ceremonies of handing the keys to the university authorities, the building was thrown open to the public for inspection.

THE WILLIAM PEPPER LABORATORY OF CLINICAL MEDICINE.

THE Laboratory of Clinical Medicine given to the University of Pennsylvania by Dr. William Pepper, as a memorial to his father was formally opened and presented to the university on December 4th. The presentation was made by Dr. John S. Billings, in the name of Dr. Pepper, who described the building and its purposes.

The building is 62 feet long, 42 feet wide, and four stories high, with a basement cellar; built of brick and terra cotta on a stone base to the first floor, with a green slate roof; and fitted up inside with tables, work benches and apparatus of various kinds. On the first floor above the basement are rooms for microscopical, for chemical and for bacteriological investigations of the secretions, excretions, outgrowths, discharges and other products from the bodies of the sick, with a balance room. On the second floor are rooms for anthropometrical work and research, the laboratory of the Director and his assistant, and a store-room. On the third floor is a large laboratory for post-graduate students, and a dark room for photographers' work. On the fourth floor are a research room for special workers, an assembly room, a library and a janitor's room.

The object of the laboratory is to advance clinical studies by original research, and the publication of results. Only graduate students of an approved medical school are admitted to the laboratory, which is said to be the only separate building devoted entirely to chemical, microscopical and bacteriological researches and to the post-graduate teaching of clinical laboratory methods. Provost Harrison accepted the gift for the Trustees of the University, and Dr. W. H. Welch, of Johns Hopkins University, delivered an address on scientific and laboratory methods.

Dr. William Pepper will be the first director of the laboratory, and nine associates undertaking original research have already been appointed.

GENERAL.

THE corner stone of the new Library of Columbia College was informally laid on the afternoon of Dec. 7. In the presence of the Trustees and several officers of the College President Lov made a few remarks and set the stone in place. The first courses of the white Indian limestone of which the building is to be constructed are now being laid, and the iron work of the interior is finished up to the main floor.

PROF. ARTHUR KENDRICK, assistant professor of physics, Worcester Polytechnic Institute, has resigned to accept an associate professorship in physics in the Rose Polytechnic Institute. Prof. Kendrick was graduated at Amherst College, and after a three years' graduate course in physics in Harvard University, was made assistant professor of the Worcester Polytechnic Institute about three years ago.

THE corner stone of the new building of the Brooklyn Institute of Arts and Sciences on Prospect Hill, opposite Prospect Park, will be laid December 14th, at three o'clock in the afternoon. The New York *Evening Post* states that Mayor Schieren will lay the corner stone, and A. Augustus Healy, President of the Institute, will preside. The principal address will be delivered by the Rev. Dr. Richard S. Storrs, President of the Long Island Historical Society and first Vice-President of the Institute. A poem for the occasion will be read by the Rev.

John White Chadwick, and brief addresses will be delivered by St. Clair McKelway, representing the Board of Regents of the State of New York, and Seth Low, President of Columbia College, as representing the educational interest of New York city. The foundations of the building, which are of Milford granite, are already laid, and the walls, which are to be of light gray Indian limestone, are now rising above the ground.

ACCORDING to *The British Medical Journal* a new surgical polyclinic, in connection with the Berlin University, will be opened very shortly. Prof. König, the successor of Dr. Bardeleben, is to be its head, and his assistant, Prof. Hildebrand, who follows him to Berlin from Göttingen, its chief surgeon.

AT a meeting held at the University of London, on November the 21st, Sir James Paget in the chair, and attended by delegates from institutions named in the report of the Royal Commission on the Gresham University, by members of that Commission and of the earlier Commission on 'A Teaching University for London,' and by others interested in the establishment of a teaching University, the following resolution was unanimously passed: "That the Government be requested to introduce, at an early date, a bill, similar to Lord Playfair's London University Commission Bill, 1895, appointing a Statutory Commission to carry out the recommendations of Lord Cowper's Commission, but with an added clause giving to all institutions or persons directly affected by any statute or ordinance proposed by the Statutory Commission a right of appeal to the Privy Council for the disallowance or alteration thereof, previous to such ordinance being laid before Parliament for confirmation."

DAVID H. HOLMES, lately of Johns Hopkins University, and at one time professor of Latin in Allegheny College, has been elected to fill the chair of Latin at the University of Kansas. This position was made vacant by the death of D. H. Robinson, who had occupied it for thirty years.

THOMAS A. JENKINS, PH. D., of Johns Hopkins University, has been put in charge of Romance languages at Vanderbilt University

in place of C. A. Eggert, Ph. D., who resigned at the close of the last session. W. H. Kirk, Ph. D., of Johns Hopkins University, has been elected instructor in Latin in the place of Frank E. Bradshaw, M. A., who died last month.

A NEW school of technology is to be established at Hartford, as a department of Trinity College.

THE University of the State of New York has published a Bulletin on Extension of University Teaching in England and America, by Dr. James E. Russell. In July, 1893, on recommendation of some of the leading members of convocation, the regents appointed Prof. James E. Russell, then of New York but now professor of pedagogy in the University of Colorado, a special commissioner to visit European educational institutions and report on whatever he might find of most importance to educational institutions in New York, and the results of his investigations are embodied in the present report.

DR. B. E. FERNOW has been appointed special lecturer on forests and forestry in the school of economics, political science and history, in the University of Wisconsin. This course of lectures will probably be the first one of the kind to be given in a school of this character. The following may be mentioned among the topics of which Dr. Fernow will treat: The state of natural resources, the nature of the forest and of its products; an idea as to what forests are, how they grow, how their materials enter into human use, the forest influences on climate, water and soil conditions; history and statistics; methods and requirements of forest management; forest yield a financial calculation; principles of forest legislation, with special reference to the United States, including the history of the forestry reform movement.

CORRESPONDENCE.

THE PERCEPTION OF DIRECTION.

THE 'inverted image' discussion in SCIENCE suggests a number of questions that have a bearing on the pertinence and validity of purely physical solutions of the problem under consideration.

Have we a special sense of direction; and if

so, to what extent can its indications be trusted without constant supervision and correction by the other senses? Can the range of the lines drawn from particular cones of the retina to the lens be determined by this hypothetical sense of direction to give any accurate notion of their real projections in space? Does the short base line from the cones to the lens remain constant in its indications under the conditions presented in the movements of the eye to secure the best adjustment for distinct vision? Would not any slight variations in this base line, resulting from movements of the eye, give a confused outline of distant objects if there were no other means of correcting the impressions received from them? Without further detail of specific inquiry the whole may be summarized in general terms, can a satisfactory solution of biological problems be obtained by an appeal to purely physical or chemical considerations?

From our present knowledge of physiological processes, it must be admitted that the physical conditions under which the impressions are made on the retina by external objects represent but a single factor in the series of complex biological activities involved in our final interpretation of visual sensations. The mutuality or reciprocity of the special senses in their relations to the cerebrum must be recognized as essential factors in the conclusions arrived at as to the real significance of the impressions received by the peripheral elements of the special sense organs.

The inverted images on the retina are evidently not directly concerned in the judgments we form in regard to the position and characteristics of the external objects that produce them. These peripheral images on the retina are telegraphed, as it were, to the central nerve organs of vision and brought into relation with cerebral activities, in connection with impressions transmitted in like manner from other sense organs to their appropriate nerve centers, and the resulting correlation of these complex interdependent processes are the basis of the judgments we habitually form in regard to the nature and position of objects in the field of vision.

That we have no specific physiological sense

of direction is manifest in the unconscious tendency to curve to the right or left in walking when blindfolded. My experiments with forty-nine young men show (*Nature* XXXII., 293; *SCIENCE* XV., 14) that this divergence from a right line is not owing to differences in the length, or strength, or dexterity of the legs, the physical factors that suggest a convenient explanation of the phenomena, but to a lack of coördination in the muscles of the legs, arising from the defective supervision of their movements by the senses.

The ability to walk in a given direction and the proper interpretation of the inverted image on the retina are alike determined by the activities of the brain, including the central sense organs, and physical considerations relating solely to the peripheral organs concerned, which take into the account but a single factor in a complex problem, cannot be accepted as furnishing satisfactory explanations of physiological processes.

MANLY MILES.

LANSING, MICH., November 27.

SCIENTIFIC LITERATURE.

Elements of the Mathematical Theory of Electricity and Magnetism. By J. J. THOMSON. Cambridge University Press. New York, Macmillan & Co. 1895. Crown 8°. Pp. vi. 510.

Electricity and Magnetism. A Mathematical Treatise for Advanced Undergraduate Students. By FRANCIS A. NIPHER. St. Louis, John L. Boland Book and Stationery Co. 1895. Crown 8°. Pp. xi. 426.

Prof. J. J. Thomson is well known as the worthy successor to the chair of Maxwell and Lord Rayleigh. He has been hitherto known chiefly for his work in mathematical physics, and latterly for his numerous experimental researches. This book exhibits him in a new light, namely, as a teacher of elementary students, and plainly declares him a master in that domain. The subject of 'Electricity and Magnetism' is one that lends itself readily to applications of many of the most difficult portions of analysis, and it is generally supposed that an exact comprehension of the various essential parts of the theory is only to be attained by those persons who possess a thorough mathe-

matical training. Maxwell's great work is a bugbear to many a student on account of the mathematical difficulties which it undoubtedly contains. How mistaken the idea is that the essentials of the theory cannot be presented to a person of but slight mathematical training, a perusal of this delightful book will show. The reviewer often recalls the words of one of his old professors in college, who was wont to ask the student who had successfully deduced some differential equation to 'translate that into English.' Prof. Thomson's book consists in doing exactly this for the whole theory of Electricity and Magnetism. In this respect it marks almost a new departure in text-books, for while we are familiar with books which, by leaving out difficulties, and by the use of the process known in England as 'Calculus-dodging,' attempt to attain simplicity, we have never before come across a treatment at the same time so full, so clear and exact, of this particular subject. There are, to be sure, two examples of this style of book. If one were asked to name the best English treatise on Thermodynamics he would still have to answer, Maxwell's 'Theory of Heat.' And yet Maxwell's 'Heat' contains very few mathematical symbols. Still if one thoroughly understands the essential principles contained in the book, and has a thorough knowledge of mathematics, he will be well able to write the mathematical treatment for himself. A second example is Maxwell's 'Elementary Treatise on Electricity,' of which we are at once reminded by the present work. Maxwell, however, there treated but a small portion of the subject, principally electrostatics. What Maxwell would have written had he lived to the present day, and treated of Magnetism and the Electromagnetic Field in general, would have probably resembled what Prof. Thomson has given us. This is perhaps a sufficient compliment, but we are tempted to use the trite illustration of the 'flower from the crannied wall,' and say that if one fully comprehended the 'all in all' of this book, he would be possessed of what is worth knowing of the modern theory of electricity, and with the help of a sufficient knowledge of Green's Theorem and the properties of definite integrals he could spin it out into two thick volumes of mathe-

mathematical treatment. How then has Prof. Thomson managed to strip off the mathematical dress and to present the naked facts? First, by a thorough familiarity with the mathematical treatment which has enabled him to seize the essential, in spite of disguise, and secondly by an unusual gift of exposition. It is only the thorough knowledge of mathematics that enables one to express mathematical truths in plain language. It is a very common opinion that a great talent for research is incompatible with excellence as a teacher. Unfortunately many instances may be cited in support of this proposition, but we contend that it is by no means necessarily true. The same faculties that make one eminent in research should also go to make him successful as a teacher. For either is necessary first enthusiasm, then a thorough acquaintance with the subject, while the teacher needs in addition only the power of saying what he has to say. Given a good style, and something to say, with a wish to teach, and we cannot see what more the teacher needs. Our present author is an example in support of our contention.

Where all is so good it is difficult to select special portions for commendation. We will, however, mention a few matters not usually well treated in elementary books. The parallel treatment of dielectrics and magnetizable bodies is clearly carried out, and the distribution of the energy in the medium, of fundamental importance in the modern theory, is carefully deduced. We are gratified to notice that the author uses in quantitative statements the expression (*unit*) *tubes of force*, rather than the usual *lines of force*. The inappropriateness of denoting the flux of induction in a dynamo by so many *lines* is illustrated by a recent letter to one of the technical journals, in which the writer makes the luminous remark that the dimensions of the unit of induction cannot be as usually and correctly given, because the dimensions of a *line* are the same as of a *length*! It seems to us to be regretted that Prof. Thomson has here, as in his large volume, made use of the term 'Faraday tubes' to denote tubes of electrical induction. Magnetic tubes are certainly as much due to Faraday as electric. The chapters on fields of force are illustrated by

numerous diagrams, some of them new. The confusing matter of magnetic force and magnetic induction is made plain, and the uniform magnetization of a sphere and of an ellipsoid worked out. The statement may be noticed that a long ellipsoid tends to place itself along the lines of force in a uniform field, whether magnetic or diamagnetic. It is so frequently stated in text-books that a diamagnetic body tends to set itself across the field that this will surprise many. The setting across usually observed comes from the lack of uniformity in the field, diamagnetic bodies being repelled from stronger to weaker regions. The correct statement was made forty years ago by Lord Kelvin, who stated, however, that the force tending to make diamagnetic bodies set along the field was probably too small to be observed. It has been observed by the present writer, and the method of observing its influence upon the time of swing of an ellipsoid has been suggested as a means of determining the permeability of diamagnetic bodies, and is now being carried out by one of his students, Mr. A. P. Wills.

Prof. Thomson gives a good treatment of electrolysis and of the electromotive force of batteries, but we think that the fact that the electromotive force can be calculated from the chemical work in the manner stated, only when the cell has no temperature coefficient, should not have been omitted. In the chapter on induction the similarity of the system of currents to a mechanical system is well brought out, and a new and very simple model described. It consists of three weights, hung from carriages rolling on three parallel rails, and kept in line by a straight bar passing through swivels on the carriages. The velocities of the outside carriages being independent, the system may be assimilated to two currents. On account of the third mass, the kinetic energy contains a term in the product of the velocities of the outside carriages, and this term gives rise to the phenomena resembling mutual induction. For instance, if one carriage is started the other goes backward, and when both are moving with constant velocities, if one is arrested the other goes faster. The disadvantage of the model comes from its simplicity, in that the coefficients of induction are constant, so that electromagnetic

forces cannot be shown, nor can induction by motion of the circuits without alteration of the currents. This can be made possible by a simple alteration. If the middle weight, instead of rolling on a fixed rail, roll on the bar connecting the two outer carriages, the coefficients of induction will vary with the position of the middle mass, and moving it along its bar while one of the outer masses is moving will cause the other to move, etc. The centrifugal force tending to make the middle mass roll along its bar will represent the magnetic force between the currents.

A number of interesting cases of induction are worked out, including a simple case of 'throttling of an alternating current' and various practical problems connected with transformers. The explanation of Elihu Thomson's interesting repulsion experiments is also simply given. Various electromagnetic measurements are worked out, including several methods of 'determining the ohm.' Finally the effects of dielectric currents are treated, and the motion of the 'Faraday tubes' and of the energy through the field. The case of propagation of plane electromagnetic waves is taken up, and the experiments of Hertz described. All this with the assumption of no more mathematical knowledge than 'an acquaintance with the Elementary principles of the Differential Calculus.' The reviewer was so struck with the absence of integral signs in the book that he counted them, and was surprised to find that there were actually fifty. Of differential equations there were, however, eighty-six. It will be granted, however, that in a book of over five hundred pages this is not too many. To return to the question of how this is done: It is, after all, by stating facts in language which, while avoiding the notation of the calculus, employs its essential concepts. We question somewhat whether this is not putting on an appearance of simplicity that is but apparent. For instance, it seems doubtful whether the expedient of dividing an area up into meshes, multiplying the force by the area of each and adding, is to be preferred to using the term surface integral in the first place. The method of the book may be characterized as that of dealing with phenomena in infinitely small pieces. It only remains to use the language of

limits and to integrate in order to have a complete treatment. If the author may be accused of calculus-dodging, however, he has done it so well that he may be forgiven, and the student is bound to be pleased. We can only congratulate those students who have the good fortune to study this subject under the personal guidance of Prof. Thomson, and we predict a large sale for the book.

Of Prof. Nipher's book, a number of the statements already made of Thomson's may be made. In spite, however, of the word 'advanced' in the sub-title of the former, and of the word 'elementary' in that of the latter, it must be admitted that Thomson's contains a good deal more meat. Prof. Nipher states also that his book "is designed for the use of students who have but recently begun to use the processes of the calculus, and it has been an incidental aim of the author to assist the pupil in acquiring possession of the machinery of mathematics. There has been no attempt to avoid any legitimate analytical method because it is not popularly known, but on the other hand there has been an attempt to avoid wasting the time of the reader over puzzles and obscurities which are made difficult and called easy." This attempt has certainly been carried out. The student will not waste his time if he reads this book. It has evidently been written with a view to the needs of the engineering student, who has been almost ignored by Prof. Thomson. It will do this engineering student good to read Prof. Nipher's chapter on electrostatics, and on energy, even if they do not assist him to design dynamos. Here again we have the parallel action of dielectrics and magnetizable bodies clearly brought out, a matter which can hardly be too strongly emphasized. Prof. Nipher recently announced the existence of 'Ohm's Law' for dielectrics as if it were something new, whereas the matter must have been evident to anyone familiar with the geometrical meaning of Laplace's equation, and was, if we mistake not, known to Faraday. Prof. Nipher has also taken the pains to invent the terms perviance, diviance and perviability, to denote the electrostatic analogues to conductance, resistance and conductivity. We trust that this will not go on to all the cases in which similar

quantities occur in mathematical physics. Du Bois, in his book on magnetic circuits, has given a table of six cases. Prof. Nipher's discovery was effusively welcomed by Prof. Silvanus Thomson, but it was amusing to find one of the English technical journals editorially refusing to admit its truth, on the ground that the current from an electrode in the form of a spherical bowl in an infinite conductor would probably not be distributed in like manner to the lines of force from an electrified bowl in air.

After the chapter on electrostatics, of the large number of examples worked out, nearly all are of practical interest. In fact, the principal complaint that we have to make of the book is that it seems written for engineering students. Practically, of course, this is the reverse of a disadvantage. There is a large amount of arithmetic in the book, which again, although repulsive to some in an 'advanced' book, will be very welcome to many. There are a number of excellent figures, some of them quite original, an interesting one being of a surface showing the doubtless dependence of the strength of an alternating current on self-induction and capacity. Although the dynamo and transformer, including the tri-phase system, receive ample treatment, there is, for those who do not find examples enough in the body of the book, a chapter of well selected problems at the end. There is also a chapter on units, in which both systems are treated, although nothing is said about keeping κ and μ in the formulas. The names given the practical units by the American Institute of Electrical Engineers are mentioned. We notice the curious spelling 'culomb,' which seems neither fish, flesh nor fowl. Each of the above books has a good index. In conclusion we may be permitted to express the wish that every student of electrical engineering might learn at least as much theory as is contained in one or the other of these books. We hope that their appearance will not cause anyone to suppose that Maxwell may now be laid on the shelf.

ARTHUR G. WEBSTER.

CLARK UNIVERSITY.

WINGE ON BRAZILIAN APES.

MR. HERLUF WINGE has recently published his fourth paper on the mammals of the province

of Minas Geraes, Brazil.* In this quarto of 45 pages the author deals with the Primates as he has already treated the rodents, bats and marsupials. The material on which the present study is based was brought to the Zoological Museum in Copenhagen by Lund and Reinhardt.

As in the earlier numbers of the series, this paper consists of three parts: (1) nominal lists of the species; (2) a detailed enumeration of the species, with critical notes on the relationships of the forms whose remains are found in the cave deposits ('Jordfundne'), and those now living ('Nulevende') in the immediate vicinity of the caves; (3) a review of the mutual relationships of the members of the group.

The paper is illustrated by two plates reproduced from photographs of actual specimens. While the results attained by this process are not as uniform as could be desired, the figures on the whole are satisfactory, especially those of the skull of *Callithrix*.

Five species of apes are represented in the collections, *Callithrix personata*, *Mycetes seniculus*, *Hapale penicillata*, *Cebus fatuellus* and *Eriodes brasiliensis* (*Eriodes 'propithecus'* Winge). Four of these are found both in the cave deposits and living in the vicinity of the caves. Except in the case of *Callithrix personata* the cave bones agree perfectly with those of recent specimens. The single femur of *Callithrix* found in the Lapa da Serra das Abelhas is slightly larger than that of living examples and has the ridges for muscular attachment rather more sharply defined, but is not specifically distinct from *C. personata*. The only extinct species is *Eriodes brasiliensis* (Lund), the living representatives of which occur in extreme southern Brazil.

Mr. Winge applies the new specific name *propithecus* to *Eriodes brasiliensis* because the other species of the genus are also Brazilian, and because the term *propithecus* originally proposed by Lund as the generic name for a group now considered congeneric with *Eriodes* should

* *Jordfundne og nulevende Ape (Primates) fra Lagoa Santa, Minas Geraes, Brasilien*. Med Udsigt over Aernes indbyrdes Slægtskab. Af HERLUF WINGE. Aftryk af 'E Museo Lundii,' en Samling af Afhandlinger om de i Brasiliens Kjøglehuler af Professor Dr. P. W. Lund udgravede Dyr- og Menneskeknogler. Paa Carlsbergfondets Bekostning udgivet ved Professor Dr. C. F. Lütken. Kjøbenhavn, 1895.

not be allowed to disappear from nomenclature.* Fortunately very few systematic zoölogists thus disregard the law of priority.

The last and most general part (pages 9 to 32) begins with a detailed enumeration of the changes that take place in the body during the evolution of the apes from ancestors with bodies in the normal, horizontal position, and in which progression took place by ordinary running and jumping. Mr. Winge's account of the development of the limbs is substantially as follows: The *Primates* were originally raised above the level of the *Insectivora* through special improvement in climbing. Even in the most arboreal of the *Insectivora* (the *Cladobatidæ*) progression is rather by running and jumping among the branches than by true climbing. The apes, however, climb very differently. The hands and feet seize and hold fast to the branches, and the limbs, especially the arms, lift the body and draw it forward. The fingers and toes clutch the branches and in this way take upon themselves the work formerly done by the claws. Since the claws serve no longer as hooks for clinging, they degenerate and become more like nails fitting the shape of the terminal phalanges which on their part are squeezed flat by the pressure of the fingers and toes upon the branches. To improve the grasping power of the hand and foot, the thumb and great toe stand out from the other digits and become opposable to them. At the same time the thumb and great toe increase in size and strength, while the positions of their articulations, as well as the form of the bones to which they are attached, are necessarily altered. As a result of efforts to accomplish a variety of movements in all directions, the limbs become more independent. The thigh and upper arm are held less closely to the sides and are no longer bound by a covering of the body skin. As the limbs become more free the muscles which work them

undergo modifications. In the arms the *supraspinatus*, *infraspinatus* and *subscapularis* increase in strength and produce great changes in the form of the shoulder blade. The *deltoidæus* shows its increased power by causing the clavicle to grow heavier. Of the muscles which work the legs the *glutei* and *iliacus internus* produce the most noticeable changes in the bones to which they are attached. Since the fore limbs are little used as supports for the body, the shoulder blades lose the nearly perpendicular position which they occupy as a mechanical necessity in most terrestrial mammals. To permit freer motion of the limbs the joints either retain the structure characteristic of the *Insectivora* or become even more loose, especially in the arm, hand, fingers and toes. At the same time the radius and ulna become mutually more free, while the latter loses its connection with the wrist. The metacarpals degenerate somewhat, becoming at length small and flat, their articulations with the proximal phalanges taking on a form which approaches the ball and socket joint. The two small sesamoid bones under each metacarpal degenerate, and the ridges on the latter on each side of which the sesamoids play disappear. The more varied the motions of a limb, the less strength exerted in each movement. The muscles of the limb become, therefore, more evenly developed, none of them increase at the expense of the others, and the bones do not give off strongly projecting ridges. Two of the movements which in most animals are performed oftenest and with most strength, the simple flexion of the elbow and ankle, are now less frequent. Hence the *triceps* and *gastrocnemius* have less influence over the other muscles, while the *processus anconeus* and the *calcaneum* have a tendency to become weaker. In the primates, entirely contrary to what occurs in ordinary running and springing animals, the arms become of more importance than the legs, because in true climbing the former are used most. The lengthening arms force the body to take on a more and more upright position during progression, so that when the arms have become very long, walking on all four feet is so difficult that it is entirely abandoned, and the body is at length held in equilibrium over the hind limbs.

*“*Propithecus* kan ikke opretholdes som egen Slægt; den falder sammen med *Eriodes*. Strengt taget skulde Arten fra Lagoa Santa derefter kaldes *Eriodes brasiliensis*, et Navn, der dog vilde være for intetsigende; ogsaa Slægtens andre Former kjendes fra Brasilien. Det er foretrukket at give Arten et 'nyt' Navn, *Eriodes propithecus*; Ordet *Propithecus* fortjener ikke at forsvinde.” No. 2, p. 24.

After enumerating in a similar manner the changes that occur in other parts of the body, especially in the vertebræ, brain and mouth, the author gives a detailed study of the inter-relationships of the different groups of monkeys and lemurs. Space will not permit an analysis of this part of the work, but the following table of supergeneric groups (p. 12), arranged according to their greater or less resemblance to the *Insectivora*, gives a concise synopsis of the conclusions reached by Mr. Winge.

- Lemuroidei.
 - Tarsiidæ.
 - Adapini.
 - Tarsiini.
 - Lemuridæ.
 - Nycticebini.
 - Otolocini.
 - Nycticebi.
 - Lemurini.
 - Lemures.
 - Propithecii.
- Ceboidei.
 - Cebidæ.
 - Mycetini.
 - Callitriches.
 - Pitheciæ.
 - Mycetæ.
 - Hapalini.
 - Cebini.
 - Cebi.
 - Ateles.
- Simiidæ.
 - Simiini.
 - Hylobatæ.
 - Homines.
 - Simiæ.
 - Cercopitheci.
 - Cercopitheci.
 - Cynocephali.

GERRIT S. MILLER, JR.

Palæozoic Fossils (Vol. 3, Part II.). By J. E. WHITEAVES. Geological Survey of Canada. Ottawa. 1895.

This publication contains two papers: (1) Revision of the fauna of the Guelph formation of Ontario, with descriptions of a few new species, and (2) Systematic list, with references, of the fossils of the Hudson River or Cincinnati formation at Stony Mountain, Manitoba. In the first paper 130 species and varieties are enumerated, and it may be considered as a complete list of the fossils so far known from the Guelph of Canada. The new species described are *Monomerella durhamensis*, *Pleurotomaria velaris*, *P. halei* var., *P. townsendii*, *Loxonema magnum*

var., *Polytropis durhamensis*, *P. parvulus* and *Illænus aboyensis*.

The second paper dealing with fossils from Stony Mountain is interesting as a systematic list of all the fossils from this lonely outlier of the Cincinnati group of the Lower Silurian. The rocks are said to be 'identical, both in their lithological and paleontological characters, with the well-known rocks of the Hudson River or Cincinnati group of southern Ohio and elsewhere.' If this be the case it is interesting to note the presence here of a species of *Favosites* (*F. prolificus*, perhaps only a variety of *F. gothlandicus*) well known as a Niagara fossil in Ohio, but not yet found in the true Cincinnati rocks. Most of the others are well-known fossils occurring in Ohio, although appearing under names not given in the older volumes on Paleontology of New York or Ohio. The plates in the pamphlet, seven in all, are beautifully lithographed. J. F. J.

Contributions to a Biography of Linnæus. By TH. M. FRIES.

Prof. Th. M. Fries, of Upsala, Sweden, has for a number of years been engaged in a critical study of the life of Linnæus, and the first instalment of his forthcoming work was some time ago published in the University Annual. The paper treats of the early life of the great naturalist up to the time of his entering the University of Upsala at the age of twenty-one.

The author is clearing away some of the fictions with which the earlier biographers have sometimes adorned their accounts of the career of the 'Flower King.'

While it is true that Linnæus did not come of a distinguished line of ancestors, the author shows that he was no exception to the laws of descent and of inheritance of mental traits, as some have made it out. His male ancestors on his mother's side belonged to the clergy and had for three generations been rectors in the same parish, and his lineage on his father's side extends into the best peasantry of Småland. It is also noted that both of his parents took much interest in gardening and in the culture of flowers. With the relatives of his father, the author says, this seems to have been an often recurring trait. An uncle of Linnæus' father,

while in the employ of the Count von Horn, of Germany, as private chaplain, devoted himself with great zeal to the study of horticulture, and laid out a garden for his master according to the requirements of the art of gardening at that time. Later on when this gentleman had returned to Sweden he planted a garden, in which were grown a number of species not previously cultivated in his native country. It was among these plants that Carl's father, Nils Linnæus, acquired a lasting interest in gardening, and several years afterwards, while a student at the University of Lund, he busied himself learning the Latin names of various kinds of plants, and 'put up with his own hand' an *herbarium vivum* of fifty plants. This was somewhat unusual for a student at that time. While rector at Stenbrohult Nils Linnæus in his turn had a garden, which surpassed everything before seen in that part of the country, and in which were found several hundred exotic, mostly ornamental, plants.

All of Linnæus' biographers tell of his early fascination for the beauties of flowers. We have heard the story of his own little plantation, maintained in a corner by itself and duplicating most things grown about the parsonage. We are informed that at the age of four his curiosity prompted him to make inquiries of his parents for the names and properties of different plants and to go out into the fields and meadows to look for flowers. It is well known that the predilections of the child early matured into the earnest inquiries of the student and the investigator. On this point there have been no opportunities for fiction or exaggeration. Not so with some other features of his earlier life. He has by some been represented as a stupid scholar in everything not pertaining to natural history. On this point Prof. Fries brings forth evidence that such was not the case.

The records of the gymnasium show that Carl Linnæus was regularly promoted, from year to year, through the several classes of the preparatory school and that he was in due time promoted to the Wexio gymnasium at the age of seventeen, ranking eleventh in a class of eighteen members. The author admits that Linnæus neglected the studies of theology, Hebrew, composition and philosophy (logic), which sub-

jects were then regarded as the most important ones, as nearly all of the students were supposed to prepare for the clerical profession or to take up, later on, an administrative career. In mathematics and in physics Linnæus was always among the best students in the class. In the Latin language he was quite proficient, even for the times he lived in, as is evident from the ease with which he used this language in his writings.

Prof. Fries throws some new light on one circumstance which has been quite generally misunderstood. The teachers at Wexio have been made the objects of much unjust censure from Linnæus' biographers for having advised his father to take the young man out of school and have him learn some trade. Even Linnæus himself in his older days of failing memory refers to the advice of these men in a piquant manner. But it is quite probable that this advice was given in the way of emphasizing their disapproval of the young man's neglect of some of his studies. Considered from this point of view, it was quite natural and proper for the teachers to give such advice to the parent of a son, who had slighted several of the subjects regarded as of the greatest importance for his future. The same course would no doubt be taken by the teachers in our own schools of to-day. The ridicule and the criticisms of these men have evidently been prompted by a desire to give a brighter lustre to a great name.

In a similar way it has been represented that on his departure for the University of Lund Linnæus was not properly recommended by the rector of Wexio gymnasium in this gentleman's letter of dismissal. But it is pointed out that this letter itself must silence such representations. The rector wrote: "As nature in the vegetable kingdom offers pleasant spectacles when she hastens and favors the growth of the plants as they are removed to a new place, so the muses pleasantly exercise their power when bidding young men with great talents take up their studies at another place. * * With this purpose the muses now call * * Carl Linnæus, a particularly excellent young man, of a good family, etc., from our gymnasium to the University." Then follow the usual good wishes for the future welfare of the scholar. The rector in this let-

ter evidently betrays an appreciation of Linnæus' character and ability and his words indicate that he had some expectations as to the future career of his pupil.

The further treatment of the later life and work of the great naturalist will be awaited with interest. The author remarks that no biography of Linnæus can do him justice, unless it be written on the basis of a thorough knowledge of all the sciences to the development of which he gave his attention. It is only by comparison of these sciences, in the condition in which they were before his time and in the state to which they were brought by his efforts as an investigator and by the powerful impetus of his teaching, that we can truly appreciate the greatness of his work and see its influences extending into our own time. In this age of specialization there is perhaps no one man who has such a wide knowledge of these branches as would be required; and a full account of Linnæus as a man of science would require the cooperation of several men interested in the different departments of natural history.

J. A. UDDEN.

AUGUSTANA COLLEGE, ROCK ISLAND, ILL.

SCIENTIFIC JOURNALS.

PHYSICAL REVIEW, VOL. III, NO. 3, NOVEMBER-DECEMBER, '95.

Variation in Electrical Conductivity of Metallic Wires in Different Dielectrics. By FERNANDO SANFORD.

In a paper published in 1892 Prof. Sanford presented the results of observations on the resistance of copper wires when immersed in different dielectrics, and reached the conclusion that the conductivity was to some extent dependent upon the nature of the dielectric, quite apart from incidental temperature changes, leakage, etc. The change observed in the resistance was small, amounting to not more than 0.2%. Since that time similar measurements have been undertaken by at least one other observer in the hope of verifying Prof. Sanford's conclusions, but without success. The original papers have in fact been quite generally and severely criticised.

In the present paper Prof. Sanford discusses the sources of error which have been suggested as accounting for his results, and calls attention to the fact that his conclusions have recently been qualitatively verified by Grimaldi and Catania with more accurate apparatus than he had himself used. The paper also contains the results of further observations on copper and silver wires. The amount of the resistance change was found to differ greatly with different samples of wire; but the direction of the change was always the same for a given material. Thus the resistance of copper was less in petroleum than in air, while with silver the resistance was found to be less in air. Strangely enough the behavior of a silver wire which had been copper-plated was almost identical with that of pure silver. The results obtained are certainly difficult of explanation, but are the more interesting on that account.

A Study of the Polarization of the Light Emitted by Incandescent Solid and Liquid Surfaces. II. By R. A. MILLIKAN.

The first half of this paper, dealing with the qualitative study of polarization by emission, has already been noticed in SCIENCE. In the present article the subject is treated quantitatively. The substances investigated were platinum, silver, gold and iron, the first two mentioned proving most satisfactory.

By means of a simple but accurate polarimeter the amount of polarization was measured at different angles of emergence. The results were then compared with the values given by Cauchy's theory of metallic reflection, upon the assumption that the polarization is due to the refraction of the rays from the interior on emerging from the surface. The agreement between the computed and observed values is quite striking, and makes it appear that refraction at emergence offers a satisfactory explanation of the phenomena in all the cases investigated. The agreement is especially good in the case of molten silver.

Observations upon the light developed by fluorescence at the surface of Uranium glass show that the light is polarized much in the same way as the rays from an incandescent surface. Here, too, the effect may be explained as a result

of refraction, and the values computed from Fresnel's theory of vitreous reflection and refraction are in close agreement with the observed amounts of polarization.

On Ternary Mixtures III. By W. D. BANCROFT.

The present article, which completes a series of three papers on this subject, deals with liquid mixtures in which two components are partially miscible, while the third is miscible with these in all proportions. The 'Mass Law' is found to hold in this case as well as in the case discussed in the previous articles. In support of his conclusions the author presents not only his own observations, but also the numerous results previously obtained by other observers. It is found that in general there are four sets of equilibria. Dr. Bancroft discusses also the question of the distinction between the solvent and a dissolvent substance, and is of the opinion that there is a fundamental difference between the two.

On the Changes in Length Produced in Iron Wire by Magnetization. By L. T. MOORE.

After a brief review of the work previously done on this subject the author describes experiments to determine the elongation of soft iron wire as a function of the magnetization. The apparatus used had a multiplying power of 37,000 and permitted the use of a field as high as 260. Precautions were taken to obtain uniform magnetization, and the latter was directly measured. It was therefore possible to plot the elongation in terms of the magnetization, rather than in terms of the field, as has usually been done heretofore. After correcting for the contraction due to the magnetic force between adjacent parts of the iron, the maximum elongation was found to occur at an intensity of magnetization of about 1,200. Beyond this point the elongation diminished. The effect of hardening was investigated, and measurements were also made when the wire was subjected to tension.

The number contains minor articles on the Limits of Pitch for the Human Voice, by W. Le Conte Stevens; and the New Physics Laboratory at Lille, by E. L. Nichols.

Book reviews: Hertz, *Electric Waves*; Glazebrook, *Mechanics*.

AMERICAN METEOROLOGICAL JOURNAL
DECEMBER.

Meteorology as a University Course. By ROBERT DEC. WARD.

The science of meteorology has been largely built up by Americans, as the names of Franklin, Redfield, Espy, Maury, Coffin, Henry, Ferrel and Loomis—known all over the world—show, and yet the study of the subject in this country is by no means as general or as systematic as it should be. The author pleads for more instruction in *general* meteorology, and advises the consideration of the various subjects in the following order: Evolution, composition and offices of the atmosphere and its relations to plants and animals; relations of earth and sun; the variations of the seasons and the distribution of temperature over the earth's surface for the year, January and July, together with a study of isanomalous and of equal annual range charts; the distribution of pressure for the year, January and July, and the resulting winds; classification of the winds; moisture of the atmosphere and precipitation; storms, including cyclones, thunderstorms and tornadoes; distribution of rainfall over the world, by seasons and for the year; weather; climate, including sanitary climatology, secular changes in climate and the relation of climate to history.

Abundant and attractive illustrations may easily be secured for such a course, as, *e. g.*, the daily weather maps, barograph and thermograph curves; temperature, pressure, wind, cloud and rainfall charts; photographs of clouds, lightning, snow crystals, damage by tornadoes, etc.

A large field of investigation is open to those who have completed a course in general meteorology, and yet who have not advanced far into physics or mathematics. Among the lines of work suggested are the following: The careful study of the climates of the different States, the effects of their topography on their rainfall, their winds and the courses of their local storms; the local effects of forests and of cultivation on rainfall; the distribution of rainfall by seasons, months and districts, and its bearing upon the times of planting and harvesting; the changes in the depth of the ground-water level, and its variations with the weather and with the season.

THE PSYCHOLOGICAL REVIEW, SEPTEMBER, 1895.

Some Observations on the Anomalies of Self-Consciousness (1): JOSIAH ROYCE. In this paper the author traces the development of the idea of self in the child, emphasizing the social influences which contribute to it, as worked out in earlier papers by himself and by Baldwin. He then attempts to account for the various disturbances of self-consciousness which are known to the students of mental pathology—and for the very large part which organic, visceral, and æsthetic sensations play in these disturbances—by derangements of the associations between the social factors in the environment and these organic bodily processes, as such associations have become established in the process of learning. Organic disturbances are therefore among the most common causes of perturbances of the sense of self, since they suggest distorted and mistaken social situations; and the reverse is true: social disturbances may bring about distorted states of the common sensibility and so work changes in the sense of self.

On Dreaming of the Dead: HAVELOCK ELLIS. This is an account of the forms which dreams about the dead take on, with actual instances reported. It suggests lines of analogy between such dreams and processes in the early history of mankind of which anthropological theory has taken notice.

Emotion, Desire and Interest (Descriptive): S. F. MCLENNAN. An analytical study of the relation of emotion, desire, and interest to one another.

Reaction-Time According to Race: R. MEADE BACHE. In this paper Mr. Bache attempts to bring to an experimental test the theory that advance in culture and in the deliberative processes characteristic of advanced stages of civilization tends to break up the reflex processes and lengthen them. With the help of Prof. Witmer, of the University of Pennsylvania, a research was carried out upon the reaction-times of ten individuals each of three races—Indians, Negroes and Whites. He found the Whites giving the longest reaction-time, as the hypothesis required, the Negroes coming next and the Indians being quickest. The relation between the Negro and the Indian he accounts for on the theory that the former has been made less quick by his ancestry of slavery,

and the Indian more quick by his method of life.

Discussion. Pain-Nerves: H. NICHOLS. A review of Prof. Strong's paper in the July number of the same Review. *Professor Watson on Reality and Time*: J. MARK BALDWIN. A review of a paper by the author mentioned in the title. *Psychological Literature, Notes, &c.*

NOVEMBER, 1895.

The Confusion of Function and Content in Mental Analysis: D. S. MILLER. This paper points out the danger and the currency of such confusion, holding that the difficulties attending certain problems which he enumerates are mainly due to it. He holds that the function of a mental content must have recognition by psychology as a matter of process, the ordinary conceptions of processes and activities getting a construction under this term 'function.' Incidentally to the main discussion there is an interesting note on Belief.

The Origin of a 'Thing' and its Nature: J. MARK BALDWIN. This paper is a long discussion of the problem as to how far the theory of the origin or natural history of a thing can give an adequate statement of its nature and value in the system of the world. It aims to bring to the bar the claim of the evolution theory that it explains things by describing their history in a developing series. The author propounds a distinction between the 'retrospective' and the 'prospective' points of view, claiming that the evolutionist takes exclusively the former; but since all growing, developing things are never exhausted at any stage to which their career has already attained, more career is always to be expected. This expectation of more career, of further development, supplies the 'prospective' reference of reality; and the habit of mind which looks forward rests on the same kind of experience of nature that the historical or evolution habit of mind does. And since all reality is an organized system, whose career is never finished in our experience, we must think also prospectively. Under this head the author brings the older conceptions of teleology, intuition, ethical values, the activity of volition, etc., *i. e.*, they are all illustrations of thinking in the 'prospective reference.'

Systems of philosophy are criticised from the point of view gained from this distinction. Finally these two habits of thought are connected respectively with the two principles of organic and mental development called Habit and Accommodation in the author's recent work on 'Mental Development.'

Some Observations of the Anomalies of Self-Consciousness (11): JOSIAH ROYCE. The conclusion of the paper with the same title in the September number. A case is given from the author's acquaintanceship illustrating the general principles laid down in the earlier paper.

The Perception of two Points not the Space-Threshold: GUY TAWNEY. A re-examination of the sensibility of the skin to differences of position when two points are touched at slight distances apart. A variety of semi-spacial distinctions are discovered when the two compass points are nearer than can be clearly distinguished; and the writer takes these vague judgments of size, direction, etc., to indicate that the distance just felt as two stimulations is not really the 'threshold' for space perception, as is generally supposed; but that there are indications of a confused 'extensity' sensation in connection with all touch stimulations.

Discussion. Physical Pain: H. R. MARSHALL. A reply to the article by Prof. Strong in the July number. *A Case of Subjective Pain*: J. H. CLAIBORNE. This note relates a case of 'a wave of pain' felt 'after an operation on the eye' simply when the absence of a friend was thought of, the pain being succeeded by pleasure when the friend was thought to be present again. *Psychological Literature, Notes, &c.*

BOTANICAL GAZETTE, SEPTEMBER.*

THE body of this issue is devoted to reporting the proceedings of the Botanical Society of America, the Botanical Section (G) of the American Association for the Advancement of Science and the Botanical Club of the A. A. A. S. The address of Dr. J. C. Arthur, as vice-president of section G, is printed in full; subject, *Vegetable Physiology*.

In the department of *Noteworthy Anatomical and Physiological Researches* Borge's 'Ueber die Rhizoidenbildung bei einigen fadenförmigen

Chlorophyceen' is abstracted by Miss Stone-man, and Meyer's 'Untersuchungen über Bakterien' by Dr. Russell.

In *Briefer Articles* Frank M. Andrews describes the development of the embryo sac of *Jeffersonia diphylla*, and Lyster H. Dewey describes a new species of *Laphania* (*L. ciliata*) from Arizona. The *Editorial* pages are devoted to a discussion of the nomenclature question apropos of the action of the Botanical Club. In *Open Letters* Mr. F. V. Coville replies to Dr. Robinson's objections in the August number to the reformed nomenclature, and Mr. C. F. Millsbaugh writes against decapitalization of specific names. Three pages of *Notes and News* close the number.

BOTANICAL GAZETTE, OCTOBER.*

New or Peculiar Aquatic Fungi, I.: ROLAND THAXTER. This is the first of a series of four papers, and deals with the genus *Monoblepharis*, of which the writer recognizes four species in this country, *M. polymorpha* Cornu, 'a second form related both to this species and *M. sphærica*,' and two new species, *M. insignis* and *M. fasciculata*. The life history of the new forms is given, together with a description of the two last named, illustrated by a lithographic plate.

The Regulatory Formation of Mechanical Tissue: F. C. NEWCOMBE. Prof. Newcombe shows in this paper how the mechanical theory of growth, as determined by hydrostatic pressure within the cell and by the resistance of the cortex, gradually grew up; points out the fact that these, its two most vital supports, have been shown to be mere assumptions; and shows that growth, and especially the formation of mechanical tissues, is self regulated and is a phenomenon of irritability, a genuine reaction to strains.

Synopsis of North American Amaranthaceæ, IV.: EDWIN B. ULIN and WM. L. BRAY. The genus *Alternanthera* is treated in this installment. Eight species are recognized. *A. Kerberi*, from Mexico, is described as new.

In the department of *Noteworthy Anatomical and Physiological Researches* Mr. G. H. Hicks gives a résumé of Massart's 'La biologie de la végétation sur le littoral Belge;' Prof. Mac-

* Issued September 25, 1895. 48 pp., 1 pl.

* Issued October 17, 1895. 40 pp., 1 pl.

Dougal gives a brief account of Meyer's recent volume, 'Wesen und Lebensgeschichte der Stärkekörner der höherer Pflanzen;' and Mr. Theo. Holm abstracts Bonnier's paper, 'Les plantes arctiques comparées aux mêmes espèces des Alpes et des Pyrénées.'

In *Briefer Articles* Thomas Meehan discusses the derivation of Linnæan specific names; Bessie L. Putnam describes three instances of day blooming in *Cereus grandiflorus* on account of retardation by cold weather; J. B. S. Norton reports for the first time the occurrence on Indian corn of *Ustilago Reiliana*, which was discovered in this country a few years ago on sorghum; and A. S. Hitchcock describes the cultivation of *Buchloe dactyloides* (buffalo grass) to determine the question of the arrangement of its inflorescence. The *Editorial* deals with the decline in interest in the A. A. A. S. shown in the Springfield meeting and the best methods of increasing the interest again. In *Current Literature* there is a review of the second edition of Mrs. Dana's 'How to Know the Wild Flowers.' In *Open Letters* Prof. Kellerman continues the discussion on nomenclature. *Notes and News*.

BOTANICAL GAZETTE, NOVEMBER.*

Recording Apparatus for the Study of Transpiration of Plants: ALBERT F. WOODS. Mr. Woods has adapted Marvin's recording rain gauge, with the assistance of Prof. Marvin, to recording continuously the weight of a plant which is losing water by evaporation. In this paper he describes and figures the apparatus and its records.

New or Peculiar Aquatic Fungi, II.: ROLAND THAXTER. In this second paper Dr. Thaxter deals with the genera *Gonapodya* and *Myrioblepharis*. To the former he refers *Saprolegnia siliquæformis* of Reinsch, and a new species which he calls *G. polymorpha*. *Myrioblepharis* is a new genus with a single species, *M. paradoxa*. Not only descriptions but life histories of these plants are given, accompanied by a handsome plate.

Observations on the Development of Uncinula spiralis: B. T. GALLOWAY. Knowledge of how this fungus passes the winter and infects its host, the grape, in the spring has been want-

ing heretofore, and the investigations of Mr. Galloway were directed to these points. The development in the course of the winter and the mode of germination of the ascospores he succeeded in ascertaining, but was unable to infect grape leaves artificially. Two plates illustrate the paper.

Notes from my Herbarium, IV.: WALTER DEANE. In this installment Mr. Deane describes his 'baby flower press' and the manner in which he secures ephemeral and delicate flowers in good condition for the herbarium, and shows its usefulness for preserving partially dissected parts.

Noteworthy Anatomical and Physiological Researches. Theo. Holm contributes a notice of Andreae's 'Ueber abnorme Wurzelanschwellungen bei *Ailanthus glandulosus*,' and of several papers upon galls. Professor MacDougal writes an account of Czapek's 'Ueber Zusammenwirkung von Heliotropismus und Geotropismus.'

In *Briefer Articles* L. H. Dewey shows, with the aid of a map, the distribution of the Russian Thistle in the United States, up to October 30, 1895. Margaret F. Boynton describes some observations on the distances to which seeds are thrown or wafted by the wind; and T. D. A. Cockerell writes of Western weeds and some alien weeds in the West. In *Current Literature* there are reviews of the 'Kew Index,' just completed, the new fascicle of Gray's 'Synoptical Flora of North America,' the eleventh volume of Saccardo's 'Sylloge Fungorum,' the fourth volume of Masee's 'British Fungiflora,' together with notices of several other smaller works. In *Open Letters* the nomenclature discussion continues, with a contribution on homonyms by J. H. Barnhart, and F. A. Bather takes Mr. Millsbaugh to task for some classical heresies anent decapitalization.

ACADEMIES AND SOCIETIES.

NATIONAL GEOGRAPHIC SOCIETY, FOURTH MEETING OF THE FRIDAY EVENING COURSE, WASHINGTON, FRIDAY, NOV. 22, 1895.

MR. E. L. CORTHELL, the well known civil engineer of New York, delivered an illustrated lecture on the Tehuantepec route and its suitability for an inter-oceanic canal.

*Issued November 17, 1895. 40 pp. 4 pl.

Mr. Cortell spoke of the efforts which have been made for centuries to find a passageway between North and South America, leading into the Pacific Ocean. Cortez was struck with the small obstacle to crossing the isthmus which he found at Tehuantepec, and obtained a grant of land where he thought the route of commerce would eventually lie. These are the very lands upon which the Tehuantepec Railroad has been built, and they are still held by Cortez's descendants.

The climatic and nautical conditions of Tehuantepec are favorable, and the country is healthful and approachable for sailing as well as steam vessels. The terminus on the Atlantic side is very near to the United States, while on the west it is naturally protected by rocky headlands. One of the most important geographical facts connected with this question is shown by drawing the shortest great circle between Panama and Yokohama. This line passes east of San Francisco, showing that all commerce by way of Panama, not only for San Francisco, but for China and Japan, must pass directly by the terminus of the Tehuantepec Railroad. A comparison will show that the Tehuantepec route has an advantage over all others of an aggregate of over 125,000 miles.

'ALASKA and Her Boundary' was the subject of an address delivered before the National Geographic Society in the Cosmos Club hall, at Washington, on the evening of November 29th, by Mr. Marcus Baker, of Washington.

By means of Canadian, American and English maps the situation of that part of Alaska's boundary line which is now receiving so much attention in the newspapers, in interviews, in Congress and by three governments was made clear. The eastern boundary of Alaska was first laid down by the convention between Great Britain and Russia in 1825. The speaker traced the history of the region in question from its first discovery by Bering in 1725 down to the convention of 1825, pointing out the three great steps of geographic progress during that century. First, the map published by the St. Petersburg Academy as the result of Bering's second expedition; second, the map resulting from Cook's

explorations of 1778, and lastly, the maps resulting from Vancouver's work in 1792-4. Mr. Baker discussed the history of these maps and pointed out their merits and demerits, dwelling on the map of Vancouver, which, he said, was remarkable for accuracy and trustworthiness.

When the Russian and English diplomatists, said Mr. Baker, agreed upon and described what is now Alaska's eastern boundary line, all the interior of Alaska was a blank on the maps. Whether Alaska and Greenland were united or separated, no man knew, and the boundary line passed almost absolutely through territory unvisited by white men. The southeastern part of Alaska may conveniently be called the Pan Handle. On Vancouver's map, which was used by the diplomatists, a well-defined range of mountains is shown, stretching in a general way parallel to the continental shore. The diplomatists took this range of mountains for the boundary, but provided that in case this supposed range should extend more than 35 miles inland, then the boundary should be a line parallel to the winding of the coast and 10 marine leagues, equivalent to 35 miles, therefrom.

The Alaskan boundary question resolves itself therefore into this: The supposed mountain range does not exist. It is therefore needful to fall back upon the alternative line, that is, a line parallel to the winding of the coast, and, further, it is necessary to determine what, within the meaning of the treaty, constitutes a coast line. Is the line to follow the high-water mark of salt water, or is it to be carried from headland across narrow inlets? This is one of the questions to be adjudicated.

As to the extreme southern part of the Pan Handle, Gen. R. D. Cameron, of British Columbia, some years ago in an official document gave a novel and startling interpretation of the treaty. It was clearly provided in the treaty that the boundary line should start from the southernmost part of Prince of Wales Island, and proceed northward up Portland Canal. General Cameron, finding that it was necessary to go some distance east along the parallel of 54° 40' to reach the mouth of Portland Canal, said the words 'Portland Canal' are palpably erroneous. Let us therefore omit them and

carry it northward up Behm Canal. The effect of this change is the transfer from American to British territory of an area about equal to that of the State of Connecticut, an area within which stands a custom house of the United States, within which formally was a military post of the United States, and within which is a large island which by act of Congress four years ago was set apart as a reservation for a tribe of Indians that left British Columbian territory for the purpose of acquiring a residence on American territory. As to submitting to arbitration the question of domination over this particular part of southeastern Alaska, the speaker declared it would be unwise, unpatriotic, and unjust to our Indian wards. He declared that the only arbitration in such a case was the arbitration of battle.

Mr. Baker's paper will doubtless be published in the National Geographic Magazine.

The meeting closed with brief remarks by Dr. W. H. Dall, of the Geological Survey, who was one of the commissioners on the part of the United States to discuss the boundary question and kindred questions with Canada, in 1887 and 1888, and by General A. W. Greely, United States Army."

W. F. MORSELL.

SCIENTIFIC ASSOCIATION OF THE JOHNS HOPKINS UNIVERSITY.

ONE hundred and twenty-second regular meeting, November 17, 1895. President Remsen in the chair.

After a few remarks by the President the following papers were presented and read:

1. *The Discovery and the Properties of Helium.* By J. S. AMES and W. W. RANDALL.

Dr. Randall told the story of the discovery of Helium and discussed its properties from the chemist's point of view. He was followed by Dr. Ames, who confined himself to the properties of the spectrum of the gas. At the end of the meeting an opportunity was afforded those present to view the Helium spectra; the gas being in tubes brought from London by Dr. Randall.

2. *The Solution and Diffusion of Metals in Mercury.* By W. J. HUMPHREYS.

Mr. Humphreys gave the results of a number of experiments on the rate and amount of solution and diffusion of various metals in mercury. Diagrams were exhibited showing the results of the investigation.

The following papers of research were then presented and read by title:

1. *Geometrical Multiplication of Surfaces:* By A. S. CHESSIN. (Annals of Mathematics.)
 2. *On Cauchy's Numbers:* By A. S. CHESSIN. (Annals of Mathematics.)
 3. *On Divergent Series:* By A. S. CHESSIN. (Bull. Am. Math. Soc.)
 4. *On a point of the Theory of Functions:* By A. S. CHESSIN. (Am. Journal of Math.)
 5. *Demonstration of the Existence of a Limit for Regular Sequences of Numbers:* By A. S. CHESSIN. (University Circulars, J. H. U.)
 6. *A New Classification of Infinite Series:* By A. S. CHESSIN. (University Circulars, J. H. U.)
- On motion the meeting adjourned.

CHAS. LANE POOR,
Secretary.

GEOLOGICAL CONFERENCE OF HARVARD UNIVERSITY, NOVEMBER 12, 1895.

The Pirna and Kirchberg Zones of Contact Metamorphism. By T. A. JAGGAR, JR.

Attention was especially called to the superb maps of the Saxon Geological Survey, the four sections Nos. 124, 125, 135 and 136, making up the Kirchberg area, and sections Nos. 82, 83 and 102 the Pirna series. Each section is accompanied by an 'Erläuterung,' or pamphlet of descriptive text. The scale of the maps is 1:25,000, and all landmarks which can be of assistance in using these maps in the field are indicated in print, such as 'quarry,' 'brewery,' 'paper factory,' etc. Specimens were exhibited of the various metamorphic series in separate suites, each suite being arranged in a long tray; a colored strip of tape attached to each set of specimens had its duplicate pinned across the map showing locality.

The Kirchberg granite stock lies on the northern flank of the Erzgebirge, south of Leipzig and southwest of Dresden, between the streams Mulde and Göltzsch. Its outcrop forms

a perfect ellipse, about seven miles long in a northeast-southwest direction, and four to five miles in breadth. It is nearly surrounded by hills of 'hornfels' or metamorphosed clay slate, whose elevation above the more easily weathered granite is well shown by the drainage. To the southeast lies a portion of the Schlema stock of tourmaline granite, also bordered by its metamorphic rim of hornfels. The metamorphic belt belongs to the non-fossiliferous Phyllite series and higher, the Cambrian slates. The alteration due to the intrusion of the granitic masses is similar in both formations. The highly crystalline zone next to the granite has an average thickness of 300m., and the outer zone of spotted schist varies from 450m. to 550m. in thickness. These measurements are made perpendicular to the original cooling surface of the granite; the many mining shafts in the vicinity of Schneeberg afford accurate data for such measurement, and show that the alteration zones are determined solely by the position of the granite, quite independently of the dip and strike of the sediments.

The Kirchberg granite stock consists of a coarse, porphyritic outer shell enclosing a somewhat later intrusion of finer grain; the contact of the two, however, shows that the older magma was still partially fluid when the younger was intruded. At the contact with the hornfels the granite often interpenetrates the slaty folia in very fine veinlets showing extreme liquidity at the time of intrusion.

At the contact the hornfels contains muscovite, biotite, quartz, andalusite and magnetite; at a distance from the contact it becomes more schistose in character, and greenish-black oblong spots appear, which are chiefly concretions of carbonaceous pigment; going further, the spots disappear, but the slaty folia still retain a crinkled appearance, until finally the unaltered clay slates are reached. The unaltered phyllite and the andalusite hornfels show great similarity in chemical composition, indicating molecular rearrangement rather than actual acquisition of new material.

The Pirna area lies southeast of Dresden, between the great Lausitzer granite stock on the northwest and the gneiss of the Erzgebirge on the southeast. A concise summary of the geol-

ogy of this contact series is given by R. Beck, *Tschermaks Mineralog. und Petrog. Mitteilungen* XIII-4-p. 290, 1893.

Southwest from the town of Pirna the altered sediments of Cambrian, Silurian and Devonian age lie in apparently conformable succession, highly inclined and striking northwest. Various granitic masses cut them, producing different metamorphic changes, according to the nature of the rock affected.

The Lausitzer Granite consists chiefly of an oligoclase-quartz-biotite granitite, which in the vicinity of Dohna is replaced by a micaceous granite. A syenite occurs further south in oblong masses parallel to the strike of the sediments, and this varies locally to hornblende-granitite in one case and to quartz-angite-diorite in another. In the southeast part of the area occurs a large granitite stock near Markersbach, characterized by pneumatolytic phenomena and intersected by veinlets which contain cassiterite, topaz, blende, zinnwaldite, tourmaline, fluorite, etc. Near it the tourmaline-granitite of Gottleuba, which shows much kataclastic alteration, occurs in a number of long lenticular masses which lie in general parallel to the strike of the associated sedimentaries. This indicates that dynamic-metamorphism played a part in the changes wrought in this basin, though Beck considers them chiefly contact phenomena, the dynamic action having taken place long after the early igneous intrusions and affecting both granites and stratified rocks alike.

The contact metamorphism observed is as follows:

The Phyllites are altered into spotted schists and andalusite-hornfels as in the Kirchberg area and elsewhere. Chlorite gneiss is altered to biotite gneiss, a somewhat unusual process (see Beck, l. c. and also C. Callaway, *Geol. Mag.* (3) 10. 535-538. 1893).

Silurian clay slates are altered to 'knoten' schists and nearer the contact to Cordierite-hornfels. Contrary to the rule observed in the phyllites, the 'knoten' in thin section are spots of less pigment than the mass of the schist, and in the hand specimen appear as tiny blisters or nodal points. A carbonaceous lydite or siliceous schist becomes graphitic near the granite contact.

Among the various members of the Weensteiner grauwacke (Devonian) formation is an interesting series of gneissoid rocks between Goppeln and Tronitz. They are feldspathic and full of cordierite, crystals of the latter mineral often attaining great size.

The diabase sheets which generally lie interbedded among the slates and conglomerates are amphibolized, and the diabase tuffs are altered to Actinolite schists.

Further may be mentioned the metamorphic limestones and their associated ore bodies. The chief interest of the region lies in the diversity of the rocks affected by contact metamorphism.

GEOLOGICAL CONFERENCE OF HARVARD UNIVERSITY, NOVEMBER 19, 1895.

Theories of Ocean Currents. By W. M. DAVIS.

The sufficiency of difference of equatorial and polar temperatures to cause a convectional circulation in the ocean has been strongly disputed by many under Croll's leadership, but warmly upheld by others, notably by Carpenter and Ferrel. The following arguments bear on the discussion:

The cross-equator current of the Atlantic, flowing obliquely from the South Atlantic eddy to the North Atlantic eddy, continually carries a great volume of water from one hemisphere to the other. The only available path for its return is as an undercurrent. Assuming that the surface currents are wind-driven, and that there is no other cause for movement of deep waters than wind-driven surface currents, it follows that the movement of the deep Atlantic water should cross the equator from north to south. But the distribution of bottom temperatures shows very clearly that the bottom movement here is from south to north. Hence the assumption that no cause but surface wind is operative cannot be permitted, and the most available other cause is gravitative convection.

On the other hand, the annual variation of velocity in the surface currents favors their direct control by surface winds rather than their indirect control by convection, as argued by Ferrel. For, if moving as part of a convectional circulation, they should move fastest when the poleward temperature gradient in the ocean water is strongest; and this is in late

summer, when the heat equator of the ocean lies poleward of the geographic equator, and the total difference of equatorial and polar temperatures is found in the minimum distance. But if driven by the winds the surface currents should move fastest in winter, for then the poleward temperature gradient in the atmosphere is strongest and then the winds blow fastest. As far as facts are reported, the eastward surface drift of ocean waters in the temperate zones is strongest in the winter season. The critical point in this argument turns on the essential constancy of temperature in the polar oceans, on account of which the variation of the poleward temperature gradient in the water depends only in the position of the oceanic heat equator; while in the atmosphere the polar temperature changes greatly with the season, and hence, in spite of the greater distance from heat equator to pole in the winter hemisphere, the gradient is then strongest on account of the great winter increase in the polar and equatorial temperature contrast. Oceanic convection should be strongest in the summer hemisphere, but atmospheric convection and wind-driven currents in the winter hemisphere. (Fuller publication in the Proceedings, Boston Society of Nat. Hist.)

T. A. JAGGAR, JR.,
Recording Secretary.

NEW BOOKS.

- The Structure and Life of Birds.* F. W. HEADLEY
London, Macmillan & Co. 1895. Pp. xx+412.
- Milk, Its Nature and Composition.* C. M. ACKMAN.
London, Adam and Charles Black.
New York, Macmillan & Co. 1895. Pp. xiv+180. \$1.25.
- Geological Biology.* HENRY SHALER WILLIAMS.
New York, Henry Holt & Co. 1895. Pp. xix+395.
- Cambridge Natural History, Vol. V.* Peripatus, ADAM SEDGWICK; Myriapods, F. G. SINCLAIR; Insects, DAVID SHARP. London and New York, Macmillan & Co. 1895. Pp. xi+584. \$4.00.

SCIENCE

NEW SERIES.
VOL. II. No. 51.

FRIDAY, DECEMBER 20, 1895.

SINGLE COPIES, 15 CTS.
ANNUAL SUBSCRIPTION, \$5.00.

GUSTAV E. STECHERT'S

Recent Importation of Scientific Books.

APEL, DR. MAX. Kants Erkenntnistheorie u. seine Stellung zur Metaphysik. Eine Einführung in d. Studium von Kants Kritik der reinen Vernunft. 147 Seiten. 8°. Mk. 3⁰⁰.

BAAS, J. HERM. Die geschichtliche Entwicklung des ärztlichen Standes u. der. medicinischen Wissenschaften. Mit 2 Abbildgn. 480 Seiten. gr. 8°. Mk. 11⁰⁰.

BIEDERMANN, W. Electrophysiologie. 2^{te} Abtheilung. Mit 149 Abbildungen. 857 Seiten. gr. 8°. Mk. 9⁰⁰.

BUCHKA, DR. KARL VON. Physikalisch-chemische Tabellen der anorganischen Chemie. 348 Seiten. gr. 8°. Mk. 10⁰⁰.

FUCHS, DR. GORTHOLD. Anleitung zur Molekulargewichtsbestimmung nach der 'Beckmannschen' Gefrier- u. Siedepunktmethode. Mit 18 Text Figuren. 14 Seiten. Cloth. M. 1⁵⁰.

GERARD, ERIC. Mesures électriques. Leçons professées à l' institut electrotechnique 'Montefiore annexé à l' université de Liège, Avec 198 figures dans le texte. 457 pages. Cloth. France 12⁹⁰.

GOMPERZ, THEOD. Griechische Denker. Eine Geschichte der antiken Philosophie. 1^{ster} Band. 478 Seiten. gr. 8°. Mk. 10⁰⁰.

GRUNMACH, DR. LEO. Lehrbuch der magnetischen u. electricchen Maasseinheiten, Messmethoden u. Messapparate. Mit 342 in den Text gedr. Holzschnitten u. vielen Tabellen. 632 Seiten. Mk. 16⁰⁰.

HAMMARSTEN, OLOF. Lehrbuch der physiologischen Chemie. 3^{te} völlig umgearb. Auflage. Mit Spectral chemie. 647 Seiten. gr. 8°. Mk. 14⁸⁰.

KIPPENBERGER, DR. KARL. Beiträge zur Reinsolirung, quantitativen Trennung u. chemischen Characteristik von Alkaloiden u. glycosidartigen Körpern in forensen Fällen, mit besonderer Rücksicht auf den Nachweis derselben in verwesenden Cadavern. 58 Seiten. 8°. Mk. 1⁵⁰.

KISSLING, P. B. Beiträge zur Kenntniss des Einflusses der chemischen Lichtintensität auf die Vegetation. 28 Seiten. gr. 8°, mit 3 Platten. Mk. 3⁰⁰.

KRATZER, DR. JUL. Der Tod durch Electricität. Eine forensisch-medicin. Studie auf experimenteller Grundlage. Mit 7 Abbildgn und Tafeln. 159 Seiten. gr. 8°. Mk. 7⁰⁰.

LE BLANC, DR. MAX. Lehrbuch der Electrochemie. Mit 32 Figuren. 226 Seiten. 8°. Mk. 4⁸⁰.

LEVY, S. Anleitung zur Darstellung organisch-chemischer Präparate. 3^{te} neu bearbeitete u. erweiterte Auflage herausg. v. Dr. A. Bistrzycki. Mit 35 in den Text gedr. Holzschnitten. 210 Seiten. 8°. In paper, Mk. 4⁰⁰; in cloth, Mk. 5⁰⁰.

MÜLLER, E. Die vermeintlichen Inductionstörungen im Fernsprechbetriebe u. deren Beseitigung. 65 Seiten. 8°. Mk. 2⁴⁰.

NERNST, W. U. A. SCHÖNFLIES. Einführung in die mathematische Behandlung der Naturwissenschaften. Kurzgefasstes Lehrbuch der Differential- u. Integralrechnung mit besonderer Berücksichtigung der Chemie. Mit 61 im Text befindl. Figuren. 309 Seiten. gr. 8°. Mk. 8⁰⁰.

OSTWALD, WILH. Die Ueberwindung des wissenschaftlichen Materialismus. Vortrag, gehalten i. d. Versammlung d. Naturforscher u. Aerzte zu Lübeck am 20^{ten} September, 1895. 36 Seiten. 8°. Mk. 1⁰⁰.

PAULSEN, DR. FRDR. Geschichte des gelehrten Unterrichts auf den deutschen Schulen u. Universitäten vom Ausgange des Mittelalters bis zur Gegenwart. 2^{te} umgearb. u. sehr erweiterte Aufl. 1^{ter} Halbband. 320 Seiten. gr. 8°. Mk. 7⁰⁰.

PLÜCKER, JULIUS. Gesammelte wissenschaftl. Abhandlungen. Im Auftrage d. Kgl. Gesellschaft d. Wissenschaften zu Göttingen, herausgegeben v. A. Schönflies und Pockels. 1^{ter} Band. Mathematische Abhandlungen, herausgegeben von A. Schönflies. Mit einem Bildniss und 73 Figuren. 620 Seiten. gr. 8°. Mk. 20⁰⁰.

PREYER, W. Die Seele des Kindes. Beobachtungen über die geistige Entwicklung des Menschen in den ersten Lebensjahren. 4^{te} Aufl. 462 Seiten. 8°. Mk. 8⁰⁰.

SMITH, DR. AUGUST. Die Alkoholfrage u. ihre Bedeutung für Volkswohl u. Volksgesundheit. Eine social-medicinische Studie für Aerzte u. gebildete Laien. Mit 7 Abbildungen. 127 Seiten. 8°. Mk. 2⁸⁰.

SPRAU, DR. ALEX. Erläuterungen zur qualitativen Analyse anorganischer Körper in Bezug auf die practischen Hilfsmittel u. den planmässigen Gang derselben. Mit 50 Abbildgn. im Text. 173 Seiten. 8°. 3⁰⁰.

WEHMER, DR. C. Beiträge zur Kenntniss einheimischer Pilze. Experimentelle Untersuchungen auf dem Gebiete der Physiologie, Biologie u. Morphologie pilzlicher Organismen. II. Theil. Mit 3 Tafeln u. 6 Tabellen. 184 Seiten. gr. 8°. Mk. 7⁹⁰.

GUSTAV E. STECHERT,

810 Broadway, New York.

Macmillan & Co.'s New Books.

Korschelt and Heider.—Text-Book of the Embryology of Invertebrates. Translated from the German by EDWARD L. MARK, Ph. D., Hersey Professor of Anatomy in Harvard University, W. McM. WOODWORTH, Ph. D. With Additions by the Authors and Translators. Part I.—Porifera, Cnidaria, Ctenophora, Vermes, Enteropeusta, Echinodermata. With Illustrations. 8vo, cloth, \$4.00 net.
. Parts II. and III. in preparation.

Nicholson.—A Treatise on Money and Essays on Monetary Problems. By J. SHIELD NICHOLSON, M. A., D. Sc., Professor of Political Economy in the University of Edinburgh. Third Edition. With a Second Part to "A Treatise on Money." 12mo, cloth, \$2.00 net.

Thomson.—Elements of the Mathematical Theory of Electricity and Magnetism. By J. J. THOMSON, M. A., F. R. S., Hon. Sc. D. Dublin, Fellow of Trinity College, Cambridge, etc. 12mo, cloth, \$2.60 net.

Külpe.—Outlines of Psychology, Based upon the Results of Experimental Investigation. By OSWALD KÜLPE, Professor of Philosophy in the University of Würzburg. Translated from the German (1893) by EDWARD BRADFORD TITCHENER SAGE, Professor of Psychology in Cornell University. 8vo, cloth, \$2.60 net.

Headley.—The Structure and Life of Birds. By F. W. HEADLEY, M. A., F. Z. S. With 78 Illustrations. 12mo, cloth, \$2.00.

Acton.—A Lecture on the Study of History. Delivered at Cambridge, June 11, 1895. By LORD ACTON, LL. D., D. C. L., Regius Professor of Modern History. 12mo, cloth, 75 cents.

Century Science Series. Edited by SIR HENRY E. ROSCOE, D. C. L., F. R. S.

NEW VOLUME.

Lyell.—Charles Lyell and Modern Geology. By PROF. T. G. BONNEY, D. Sc., LL. D. F. R. S., etc. With Portrait. 12mo, cloth, \$1.25.

McCormick.—The Alps from End to End. By SIR WILLIAM MARTIN CONWAY. With 100 Illustrations by A. D. MCCORMICK. Large demy 8vo, cloth, \$7.00.

Meyrick.—A Handbook of British Lepidoptera. By EDWARD MEYRICK, B. A., F. Z. S., F. E. S., Assistant Master of Marlborough College. With Illustrations. 12mo, cloth, \$3.75.

Tait.—Dynamics. By P. G. TAIT, M. A., Sec. R. S. E., Honorary Fellow of St. Peter's College, Cambridge, Professor of Natural Philosophy in the University of Edinburgh. 12mo, cloth, \$2.50 net.

Tarr.—Elementary Physical Geography. With 267 Illustrations and 29 Plates and Charts. 12mo, cloth, \$1.40 net.

Trevor-Battye.—Ice-Bound on Kolguev. By AUBYN TREVOR-BATTYE, F. L. S., F. Z. S., etc. With numerous Illustrations and Drawings and 3 Maps. Large 8vo, cloth, gilt top, \$7.00.

Menschutkin.—Analytical Chemistry. By N. MENSCHUTKIN, Professor in the University of St. Petersburg. Translated from the Third German Edition, under the supervision of the author, by JAMES LOCKE. 8vo, cloth, \$4.00 net.

MACMILLAN & CO., 66 Fifth Avenue, New York.

SCIENCE

EDITORIAL COMMITTEE: S. NEWCOMB, Mathematics; R. S. WOODWARD, Mechanics; E. C. PICKERING, Astronomy; T. C. MENDENHALL, Physics; R. H. THURSTON, Engineering; IRA REMSEN, Chemistry; J. LE CONTE, Geology; W. M. DAVIS, Physiography; O. C. MARSH, Paleontology; W. K. BROOKS, Invertebrate Zoology; C. HART MERRIAM, Vertebrate Zoology; S. H. SCUDDER, Entomology; N. L. BRITTON, Botany; HENRY F. OSBORN, General Biology; H. P. BOWDITCH, Physiology; J. S. BILLINGS, Hygiene; J. MCKEEN CATTELL, Psychology; DANIEL G. BRINTON, J. W. POWELL, Anthropology.

FRIDAY, DECEMBER 20, 1895.

THE LAW OF THE LONG RUN.

CONTENTS:

| | |
|--|-----|
| <i>The Law of the Long Run</i> : T. C. MENDENHALL..... | 825 |
| <i>Horticulture at Cornell</i> : L. H. BAILEY..... | 831 |
| <i>On School Hygiene</i> : EDWARD M. HARTWELL..... | 839 |
| <i>A Simple Apparatus for Collecting Samples of Water at Various Depths</i> : G. C. WHIPPLE..... | 841 |
| <i>The Lobachévski Prize</i> : GEORGE BRUCE HALSTED..... | 842 |
| <i>American Society of Mechanical Engineers</i> | 843 |
| <i>Current Notes on Anthropology (XVI)</i> :— <i>The Pithecanthropus erectus; Affinities of the Chaco Languages</i> : D. G. BRINTON..... | 845 |
| <i>Scientific Notes and News</i> :— <i>Astronomical</i> : H. J. <i>Bibliographies of the Sciences; The Anniversary Meeting of the Royal Society; The American Society of Naturalists; General</i> | 845 |
| <i>University and Educational News</i> | 849 |
| <i>Discussion and Correspondence</i> :— <i>A Last Word on Erect Vision</i> : JOSEPH LE CONTE. <i>Mountain Climbers and the Perception of Distance</i> : HIRAM M. STANLEY. <i>Mr. Spencer on Tactual Perception and 'Natural Selection'</i> : J. MCKEEN CATTELL. <i>Bibliography of North American Paleontology</i> : CHARLES R. KEYES..... | 850 |
| <i>Scientific Literature</i> :— <i>Meyrick's Handbook of British Lepidoptera</i> : S. H. SCUDDER. <i>Debierre's Atlas d'ostéologie</i> : FRANK BAKER. <i>Pilsbry's Catalogue of the Marine Mollusks of Japan</i> : W. H. DALL..... | 854 |
| <i>Academies and Societies</i> :— <i>The New York Section of the American Chemical Society</i> : DURRAND WOODMAN. <i>The Anthropological Society of Washington</i> : GEORGE R. STETSON. <i>Geological Conference of Harvard University</i> : T. A. JAGGAR, JR. <i>Alabama Industrial Scientific Society</i> : EUGENE A. SMITH. <i>St. Louis Academy of Science</i> : A. W. DOUGLAS..... | 856 |
| <i>Scientific Journals</i> :— <i>The American Geologist</i> | 860 |
| <i>New Books</i> | 860 |

MSS. intended for publication and books, etc., intended for review should be sent to the responsible editor, Prof. J. McKee Cattell, Garrison on Hudson, N. Y.
Subscriptions and advertisements should be sent to SCIENCE, 41 N. Queen St., Lancaster, Pa., or 41 East 49th St., New York.

"MEN were surprised to hear that not only births, deaths and marriages, but the decisions of tribunals, the results of popular elections, the influence of punishments in checking crime, the comparative values of medical remedies, the probable limits of error in numerical results in every department of physical inquiry, the detection of causes, physical, social and moral, nay even the weight of evidence and the validity of logical argument, might come to be surveyed with the lynx-eyed scrutiny of a dispassionate analysis."

So wrote Sir John Herschel, a good many years ago, of the *Calculus of Probabilities*, which had just come into prominence through important practical applications. The 'Doctrine of Chance' is apparently miscalled because it is chiefly applied to the study and development of natural laws in the operation of which there can be no such thing as chance.

Popularly the word 'chance' is often used as if to imply the *absence* of any cause, but this is an unreasonable, if not an unthinkable condition. Really such words as 'chance,' 'accident' and the like imply only the absence of any assigned or recognized cause, and the doctrine of chances is a study and development of the laws relating to a series or aggregation of events, concerning the individual components of which we are absolutely ignorant. Thus, if

one tosses a coin, it is, in general, impossible to know in advance on which face it will rest. That its behavior in this respect will be governed by the operation of forces and conditions, just as certain and just as definitely compelling a given result as is the behavior of the sun and moon in the matter of an eclipse, will not be denied. If in any particular trial we knew all of the forces and conditions which influenced the result we should find that they were never equally balanced between the two possible events, but always predominated in favor of that which actually happened. A complete knowledge of antecedent causes would reveal the fact that each of these (to us at present unknown) forces and conditions is subject to other secondary influences which continually change its resultant effect from one side to the other, and so on, in lower degree, to the end *that in a very large number of trials* the ratio of the number of times the two possible events have occurred becomes very nearly one, to which, indeed, it approximates continuously as the number of trials increases. Note the use of the word *ratio* in this statement. In a very large number of trials in tossing a coin the number of heads may be always in excess of the tails and by a continually increasing amount, and yet the ratio of the two may be continually tending towards equality. It is important to call attention to the dependence of the Theory of Chances upon experience and experiment. It is not rigorously true, as is often stated in writing about probabilities, that if a coin is tossed in the air "it is as likely to fall upon one face as another." Such a condition necessitates an absolutely equal division of all forces and conditions between the two possible events, and it is logical to conclude that neither would happen. A more nearly correct statement would be that we are quite ignorant of any cause tending to one result rather than to another. As there are, ap-

parently, but two possible results we may put the *a priori* probability of each at one-half. This conclusion is, however, of little value until experience has proved that in the case under consideration the controlling forces and conditions are so evenly distributed and nicely adjusted that the balance is easily thrown from one side to the other. If experience shows that in a certain series of trials there is a marked tendency for a coin to fall on one face rather than the other we are led at once to suspect that there is something in the manner of tossing, or in the nature of the coin itself, or in some other less easily understood condition, which has caused this tendency, and we know that our numerical expression for the probability cannot be correct. Experience, therefore, is essential to any useful application of this doctrine, and experience is valuable only when it is large. The numerical evaluation of a probability must be, at least, one which is not contradictory to experience and, whenever possible, it must be one supported and verified by experiment.

The above general remarks on the Doctrine of Chances (with apologies to the many who are quite familiar with the subject) are submitted with a desire to aid in clearing away some of the difficulties which many people encounter in trying to understand the usefulness of this most interesting branch of applied mathematics. In scientific investigation whenever our knowledge is so nearly complete and our mental vision so far reaching that we can trace the progress of the phenomenon under consideration, or of each of its elements from beginning to end, we do not need its aid. In the thousands of instances, however, in which primary causes are so obscure and so numerous that we can only know them by their integrated effects, its assistance has proved to be of incalculable value.

The object of the present article is to remind the reader that whenever the number

of these elementary controlling forces and conditions (generally quite unknown as such) is sufficiently large there will be a *definite integral*, which becomes more stable in form and character as the number from which it is derived increases, and that it may be depended upon and treated with as much confidence as if it were an observed and explained phenomenon. This is, of course, the basis of all statistical studies of natural phenomena. One or two simple illustrations may be given. In the case of tossing a coin it may be impossible to discover by any physical examination of the coin itself, or of the conditions influencing it when thrown in the air, any reason for the appearance of one face rather than the other. The *a priori* probability of the appearance of a given face may, therefore, be properly put at one-half. But in ten thousand trials there might be shown a tendency towards the appearance of heads, and if this persisted with an increase of the number of trials it would be legitimate to conclude that the coin was not uniform or symmetrical in structure or that the balance of forces and condition in tossing was not good. The universality of this principle has given rise to the idea of the *long run*, or, as it is sometimes put, the Law of the Long Run. In simple language this means that however obscure or relatively ineffective an influencing condition may be, *in the long run* it will make itself felt and may be evaluated in quantity and character if the number of examples is sufficiently great. It will be observed that this principle is different from, although not necessarily inconsistent with, the statement often made that minor departures from a general law, due to minute and continually varying influences, will, 'in the long run,' cancel and destroy each other.

It is not necessary to quote examples of the useful application of this principle of the long run in bringing to light hitherto unsuspected relations or unconsidered influ-

ences, but I may be allowed to refer to one simple and easily understood illustration, an account of which was published about ten years ago. It was founded on the following reasoning: An author with a generous vocabulary at his service must be continually making a choice among words that are nearly identical in meaning. The influences which control the choice are often numerous and doubtless generally unrecognized, but in the long run a certain set will prevail and the composition will be marked by this characteristic. It might not be impossible to discover the existence of each separate influence by an extensive analysis of the author's composition in such a manner as to reveal the characteristic of this influence to the exclusion of all others, but the labor of doing this would in many cases be enormous. In the paper referred to, the simple and easily reached characteristic dependent on the number of letters in the words used was proposed, and it was shown that when properly analyzed the composition of any author could be made to produce what was called a 'characteristic curve,' which, it was suggested, might prove to be peculiar to him and which might thus afford a clue to his identification. Some further applications of the suggested method have been made since the time of first publication which have tended strongly to confirm the view then held.

The application of the calculus of probabilities to the determination of life expectation and other quantities of great importance to life insurance and annuity companies has long been admitted, and statistical methods based on the principle of the long run have long been in vogue in the study of the distribution and prevalence of disease. There is good reason for believing that what is ordinarily known as purely accidental death and injury is governed in distribution by the same inexorable laws.

For illustrations of this proposition I am indebted to an officer of one of the great railway systems of the country, who has kindly furnished, during the past three or four years, most interesting statistical information relating to accidents, collected by him with the object of studying the results in the interests of the corporation with which he is connected. I have put the principal results in graphic form, but for those who like to see the numbers from which the diagrams were constructed I have included tables showing the classification of accidents, as to occupation, results, etc. Four years are included in this investigation, and there is shown in the tables and diagrams the average for the whole period.

on the track or other property of the corporation. The meaning of the diagrams will be readily seen, the circle, in each case, being divided into sectors proportional to the number of accidents in the several classes, the whole area representing the total in every instance, *regardless of the numerical magnitude of that total*, approximate constancy of *ratio* of distribution being the point under consideration. The persistency of this ratio is certainly very striking. Naturally the railway corporation collects this information with the view of being benefited by it, and therefore it may be expected that, as its character is developed from year to year, the operation of what has been called 'chance' in controlling the distribution of accidents will be

TABLE A.—CLASSIFIED AS TO OCCUPATION.

| | NUMBER OF CASUALTIES. | | | | | RATIO OF DISTRIBUTION. | | | | |
|-----------------------------------|-----------------------|-------|-------|-------|-------|------------------------|-------|-------|-------|-------|
| | 1891. | 1892. | 1893. | 1894. | Mean. | 1891. | 1892. | 1893. | 1894. | Mean. |
| Passengers | 257 | 221 | 281 | 130 | 222 | 7.6 | 5.4 | 6.6 | 4.2 | 6.0 |
| Travelers on public highway | 190 | 239 | 179 | 195 | 201 | 5.6 | 5.9 | 4.6 | 6.3 | 5.6 |
| Employés | 2488 | 3105 | 3087 | 2339 | 2755 | 73.4 | 76.6 | 77.4 | 75.7 | 75.7 |
| Trespassers..... | 455 | 492 | 447 | 430 | 456 | 13.4 | 12.1 | 11.4 | 13.8 | 12.7 |
| Total | 3390 | 4057 | 3994 | 3094 | 3634 | | | | | |



FIG. 1.

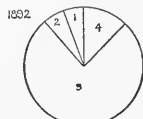

FIG. 2.



FIG. 3.



FIG. 4.



FIG. 5.

OCCUPATION.

1. Passengers.

2. Travelers on highway.

3. Employés.

4. Trespassers.

The first five diagrams show the distribution of accidents among the various occupations of the injured, at the time of the injury. The division is into the four general classes of passengers, employés, travelers on the public highways and trespassers

interfered with by new influences which will tend strongly to diminish the number of casualties, especially in those classes in which accident is most costly to the corporation. The results exhibited herewith furnish evidence that this influence is already felt.

It might be claimed that this constancy of ratio of distribution of casualties among the four classes is only a reflection of the constancy of the ratio of the numbers of those classes. It will be noted, however, that in the case of only two of them can anything be known of that ratio and, indeed, in these two only can it be anything like constant. Travelers on the public highway and trespassers can only come into the enumeration when they become victims of casualty.

An examination of the detailed figures as shown in Table A is instructive, as bearing on this question. Consider, for example, the two classes, impossible to enumerate in total, referred to above. The percentage of the total number of casualties affecting travelers on the highway does not vary greatly in the two years 1891 and 1892, being 5 % in 1891 and 5.9 % in 1892. The actual number of casualties, however, was 190 in 1891 and 239 in 1892, a variation of

over 25 %. Is there any reason for assuming that more travelers on the highway were exposed to injury in 1892 than in 1891? In 1892 the number of persons injured was 700 greater than in 1891. If the method of investigation now begun be maintained for a sufficient length of time, causes for such variations in the total and in the distribution will undoubtedly be discovered. Whatever might have been the cause, in the present instance, of the increased number of casualties, it looks very much as if the increased vigilance exercised over the safety of passengers had shunted a part of the hazard over to the employés and travelers on the public highway, although there is no marked increase of percentage in either case. The matter might be put in this way: Seven hundred more people will be injured this year than last; employés and travelers on the highway will get a little more than their share of the increase, because the corporation is going to take a lit-

TABLE B.—CLASSIFIED AS TO NATURE OF INJURY.

| | NUMBER OF CASUALTIES. | | | | | RATIO OF DISTRIBUTION. | | | | |
|------------------------------|-----------------------|-------|-------|-------|-------|------------------------|-------|-------|-------|-------|
| | 1891. | 1892. | 1893. | 1894. | Mean. | 1891. | 1892. | 1893. | 1894. | Mean. |
| | | | | | | % | % | % | % | % |
| Death..... | 348 | 366 | 341 | 266 | 330 | 10.3 | 9.0 | 8.5 | 8.6 | 9.1 |
| Loss of limb..... | 90 | 90 | 84 | 71 | 84 | 2.7 | 2.2 | 2.1 | 2.3 | 2.3 |
| Loss of finger or toe..... | 101 | 121 | 105 | 79 | 102 | 3.0 | 3.0 | 2.7 | 2.6 | 2.8 |
| Spinal injury..... | 15 | 51 | 105 | 21 | 48 | .4 | 1.3 | 2.7 | .6 | 1.3 |
| Fracture or dislocation..... | 225 | 269 | 268 | 194 | 239 | 6.6 | 6.6 | 6.6 | 6.2 | 6.5 |
| Sprains..... | 369 | 426 | 362 | 411 | 392 | 10.9 | 10.5 | 9.1 | 13.5 | 11.0 |
| Cuts and bruises..... | 1522 | 1913 | 1893 | 1134 | 1615 | 44.9 | 47.2 | 47.4 | 36.6 | 44.0 |
| Miscellaneous..... | 720 | 811 | 836 | 918 | 821 | 21.2 | 20.2 | 20.9 | 29.6 | 23.0 |



FIG. 6.



FIG. 7.



FIG. 8.



FIG. 9.



FIG. 10.

RESULTS.

- 1. Death.
- 2. Loss of limb.
- 3. Loss of finger or toe.
- 4. Spinal injury.
- 5. Fracture or dislocation.
- 6. Sprains.
- 7. Cuts and bruises.
- 8. Miscellaneous.

tle extra care of the passengers. The fourth class, the trespassers, seem, as usual, to have looked out for themselves and to have come out with a little less than their share of damage as shown by the previous year's experience.

The numbers for the year 1893 are interesting. This included a period of excessive passenger traffic, under conditions likely to considerably increase the total number of casualties. It was really, however, little different from and somewhat less than for the year 1892. Nor is the variation in ratio of distribution great, the several percentages agreeing well with the mean of the whole period.

But the most curious and interesting result brought out by the investigation is the constancy of ratio of distribution of *injuries among various classes*, such as death, loss of limb, loss of finger, fracture, etc. It is difficult to estimate the *a priori* probability of any one of these occurrences, and the facts here cited furnish a remarkable illustration of the operation of the principle or Law of the Long Run, as defined above. Indeed, in numbers relatively so small it is extremely surprising to find so many instances of persistency. General results as to character of injury and without reference to occupation are shown in diagrams 6, 7, 8, 9 and 10, and also numerically in Table B. We are here treating a total of about 15,000 casualties, an average of something less than 4,000 per annum. It would hardly have been expected in advance that during these four years there would be a nearly constant percentage of the total number of injured who would lose a limb, or that year after year almost exactly the same proportion would lose a finger or toe, or that the ratio of fractures and dislocations to the whole would be still more persistent, and this notwithstanding the fact that the total number of casualties would vary more than thirty per cent. Even

when the analysis is carried much further there appears striking evidence of the same uniformity of distribution, although naturally there might be much less of it. In illustration of this I may cite the following: When the class of employes alone is considered and their injuries classified into the eight groups above referred to, in the two groups which contain the number of those who have suffered from loss of limb, or loss of finger or toe, injuries in which there is little chance of mistake in diagnosis, we find:

| | Total Number. | | | | Percentage of Total Number of Injuries. | | | |
|----------------------------|---------------|------|------|------|---|------|------|------|
| | 1891 | 1892 | 1893 | 1894 | 1891 | 1892 | 1893 | 1894 |
| Loss of limb.. | 34 | 35 | 34 | 26 | 1.4 | 1.1 | 1.1 | 1.2 |
| Loss of finger or toe..... | 89 | 110 | 94 | 74 | 3.2 | 3.4 | 3.4 | 3.3 |

Thus while the actual number of casualties varied considerably, the proportionate distribution remained extremely constant, particularly in the case of the loss of finger or toe. Although agreement in results where the numbers involved are not large must, itself, be regarded as fortuitous, it is interesting to note that in the class of trespassers, composed, it may be assumed, very largely of 'tramps,' of whom little regularity of any kind might be expected, and of whom about 450 are annually injured in one way or another, the ratio of loss of limb was in 1891, 10.8%; in 1892, 9.7%; in 1893, 9.4%, and in 1894, 9.8%. Of the same uncertain class, it is curious that in 1891, 8 suffered the loss of a finger or toe; in 1892, 9 suffered in the same way; in 1893, 8; but in 1894 this was reduced to 4.

Examples might be multiplied to almost any extent, but it is believed that enough has been shown to establish the existence, in this instance, of the principle under consideration. Indeed, so strong is the evi-

dence that we may feel quite justified in declaring that some error has crept into the classification of the injuries included in the three groups, sprains, cuts and bruises, and miscellaneous, as shown in the table for the year 1894. In short, it is more probable that error exists, either clerical, or arising from unusual professional carelessness in diagnosis, than that percentages of distribution, which have persisted so regularly during the three preceding years, should suddenly change to the extent shown in the table.

It is quite likely that the several accident insurance companies of the country have accumulated material relating to fortuitous events much more extensive than the above, which would yield equally interesting results if subjected to analysis.

There is one point to which it seems worth while to invite especial attention, namely, the confusion which often exists as to the inherent improbability of certain events. Such events are those which, for reasons entirely independent of the probability of their occurrence, have a particular interest. As an illustration, I may refer to the chance of the appearance of a particular hand at whist. Two or three years ago those interested in games with cards were greatly excited by the alleged occurrence of an event in the Boston & Albany railroad station in Boston. It was nothing less than that during the progress of a game of whist played by three railroad conductors and a mail agent, while waiting for the hour of departure of their trains, on taking up the cards after a deal each man found himself in possession of the whole thirteen cards of one suit. The *a priori* probability of such an event is all but infinitely small, and it was thought to be necessary to fortify the account published with affidavits of all the players and also of one or two gentlemen who happened to be watching the game. It probably oc-

curred to few who read this account that the chances against any other particular distribution of the cards were just as great as against this, and that the result of every deal of the cards is just as remarkable as this and as little likely ever to occur again in the lifetime of the players. Indeed, any event of life, when considered in connection with contemporaneous and related events, in all their ramifications, will be found to have a *priori* chances so overwhelmingly against it that it seems impossible that it ever should happen. An 'accidental' death, for example, is an event generally unlikely, but in any specific case enough collateral circumstance and related fact can always be found to render the *a priori* probability of the combination nearly infinitely small. The chances of any man whom you may name meeting his death by falling from the third-story back window of the house belonging to his grandmother on his mother's side, and impaling himself on the point of a cotton umbrella accidentally left wide open in the garden below by the man servant of a gentleman named Witherspoon, temporarily stopping at the nearest inn, to whom he had loaned it on the day before at 2 P. M., in the lull of a thunderstorm which came from the north, are indefinitely small; yet I have been told that a man actually lost his life in just that way, and it is easy to see that the exact repetition of the simplest event in life, with all of its accompanying conditions and relations, would be just as incredible as this.

T. C. MENDENHALL.

WORCESTER POLYTECHNIC INSTITUTE.

HORTICULTURE AT CORNELL.

IN response to a request from the editor of SCIENCE, a brief outline of the purposes and methods of the work in horticulture at Cornell University is here given. This is the more willingly given because no full statement has been made of the capabilities

which the subject of plant cultivation offers as a means of education. Horticulture is ordinarily taught in a technical or professional way, as a direct training for the intending farmer or gardener; but the purpose at Cornell has been much different, and it may be said broader than this. The subject seems to be capable of adding much to the value of a course of liberal academic training. In the older fields of education such an outline as is here proposed might seem to be presumptuous, but in view of the novelty of the present subject and the awakening interest in it the sketch may perhaps be pardoned.

MATERIAL EQUIPMENT.

Before proceeding to the more important aspects of the subject the reader may desire to know something of the facilities for the teaching of horticulture at Cornell. The material equipment is not large. It is exceeded in several other institutions in the country. If landscape gardening be added to the subject it must be said that the equipment and facilities in this theme are practically nothing. The horticultural department comprises two diverse yet cognate lines of effort, the teaching and the research. The latter is commonly known, now that the experiment station idea is widespread, as experiment work. The same lands and glass houses serve the two purposes. About ten acres of hilly and uneven land, upon which a miscellaneous but not large collection of fruits is growing, are allotted to the department. Something over an acre of this area is set aside for flower growing. The glass houses comprise eight structures, all connected, with an aggregate glass area of less than 9,000 square feet. These are plain, cheap structures, of which the total original cost, including heaters, was about \$4,000. They are of the forcing-house type, and are adapted to the growing of the ordinary

commercial crops, such as winter melons, cucumbers, tomatoes, lettuce, beans, carnations, chrysanthemums and the like. There are no museum collections, except a very valuable and rapidly growing herbarium of cultivated plants, in which there are now about 9,000 specimens. The small equipment is admirably supplemented in some directions by the orchards and gardens of the State, for it is the purpose to rely much upon the actual condition of horticulture in the Commonwealth as a basis of experiment and research. There are many experiments of importance which are now going forward on the farms of New York State; and whenever the investigation is of such a character that it can be conducted satisfactorily off the University premises it is in some respects better for the alienation, because it spreads the work before a larger constituency and ensures an accurate measure of its practical worth. But for teaching purposes these remarks will not apply.

THE MOTIVE OF INSTRUCTION.

The teaching of horticulture is of very recent origin. There are only two or three professorships of horticulture, uncombined with related subjects, in the whole country. The teaching of both agriculture and horticulture is commonly conceived of as a training for actual participation in these occupations. Most of the agricultural colleges are essentially training schools, at least so far as these subjects are concerned, and it is incontrovertible that they have exercised a powerful influence for the betterment of rural life. The Cornell teaching aims not so much to make farmers as to educate farmers' sons and daughters. In other words, its fundamental idea is to give those students who anticipate a rural life such a breadth of training as will put them into touch and sympathy with the traditions of education, with all the larger movements of the day, and which shall enable

them at the same time to understand the fundamental reasons of their own occupations. There is less attempt to apply the teaching upon the University farm than to instill a desire to master the underlying principles of agriculture. There is, therefore, no compulsory labor system any more than there is in the teaching of engineering or archaeology. The student can ill afford the time while at college to perform mere manual labor. He must give all his strength to the acquirement of knowledge, and even then he finds four years all too short in which to grasp the essential principles of the complicated rural pursuits. Teaching is done by class exercises and by laboratory work, as it is in all other scientific and technical subjects at the present day. If the student hears a lecture upon the philosophy of the rotation of crops he also goes for a walk with the professor over the fields of the University farm and of adjoining lands and there observes the good and bad points of farm management. Or, if he hears a lecture upon winter tomatoes he also goes with the instructor, or alone, from day to day, and studies the tomatoes as they grow under glass. The sum of education as it applies to rural affairs is comprised in the two words, judgment and management; and the student needs to have his mind opened by thinking upon economics, language, history and general science quite as much as upon some of the particular subjects with which he is to deal in a more intimate way. The student should be a citizen before he is a farmer.

If the student once masters principles he is able of his own resources to apply them. Yet many mature students come to us—some of them graduates—who have been taught the applications, the methods of doing farm work, but who are greatly ignorant of the fundamental principles upon which these applications rest. From all these remarks it is apparent that much of

the teaching does not lead directly, of itself, to better farm practice, but it aims to educate the student. Its effect upon the student is certainly salutary. As soon as he comes to learn that agricultural practice rests upon certain great laws, the operation and control of which are largely in his own hands, he becomes enthusiastic and develops a deep and abiding love for rural life. This result is not obtained by the mere training school.

HORTICULTURE AS A SCIENCE.

Speaking more specifically of horticulture, it may be said that the subject has merit as a science. A single illustration will suffice, without touching upon all the immediate science of cultivation and of vegetable physiology. The one greatest conception before the human mind at the present time is evolution. Data are demanded from every source. Upon the organic side, and within the realm of readily observable phenomena, the two greatest sources of facts in support of the hypothesis of evolution are paleontology and horticulture. My reader will no doubt at once accuse me of unseemly assurance in daring to associate horticulture with a science of such importance. Paleontology derives its chief interest from the fact that it spreads the broken pages of the old book of life before our eyes. Horticulture shows the movements in operation. Six thousand and more species of plants are widely cultivated, and most of them are broken up into many forms under the touch of the operator. Some species have produced thousands of distinct forms. These forms are recorded, and of many of them the exact methods and reasons of the genesis are known. A vast panorama of varieties, or 'incipient species,' as Darwin called them, is passing daily before us. Men talk of the probable influence of climate upon plants; the horticulturist can cite you definite cases by the

score showing influence of climate and in which there are no elements of conjecture. They speculate upon the transmission of acquired characters; the horticulturist knows that they may be transmitted, and he can furnish the proofs. Men want to know what may be the influence of selection, of struggle for life, of the change of soil or moisture or any other feature of environment; the horticulturist cites you to exact cases, before your very eyes, for these are the tools with which from the earliest time he has wrought and moulded the vegetable world at his will. You ask that a new species be created; the horticulturist has done it time and again, and he has the proof of botanical classification—which was made in ignorance of the origin of the given form or species—to show that the form really does rank as a good species; or if you will not accept the opinion of botanists or the testimony of your eyes, as to the real specific distinctness of the new form, the horticulturist will show you a hundred species of cultivated plants of which no one knows the original forms, because the present type is so unlike the original one that we have not yet been able to connect the one with the other. Twenty thousand new forms is a very conservative estimate of the number which the horticulturist has produced by changes in the conditions of life and by his efforts of selection. He, therefore, is of all men the one to talk about evolution, for he has his knowledge first-hand from nature. Paleontology is the Egyptian hieroglyphic; plant culture is the last revised edition of the record of the life process.

COURSES OF INSTRUCTION.

The courses of instruction now offered are twelve: The evolution of cultivated plants; the literature of horticulture; the botany of cultivated plants; the propagation of plants; pomology, or fruit raising;

olericulture, or vegetable gardening; floriculture; greenhouse construction and management; the theory and practice of the spraying of plants; landscape gardening; instruction in handicraft; investigation for advanced students.

Some of these courses are given as seminaries; that is, the students and instructor meet informally in a small room and discuss the subject of the day. Let us take the course upon the literature of horticulture as an illustration. There are no bibliographies of horticultural writings and no collections of books which intend to be complete. All this is proof that horticulture has had few students in this country. This course is the only one of its kind ever given, so far as we know. The University library has a fair collection of horticultural books, and the writer's collection of American horticultural literature is the most complete in its line. From these collections the course draws its supplies. The following subjects have been taken up for discussion so far this term:

The herbals; Roman literature; literature of landscape gardening; European grape literature; American grape literature; French literature; early American literature; German literature; current American literature; English literature; periodical literature.

The chief writings illustrating these various topics are taken to the seminary room, where they are freely discussed, the teacher acting more as a leader of the discussion than as an instructor.

Students frequently lead these discussions. This is particularly true of the seminary on greenhouses, now in progress. In this course the following subjects have been under review this term: Evolution of the greenhouse; side walls and foundations; roofs; interior arrangements; methods of heating; ventilation; styles of houses for particular purposes; glass and glazing; watering; pots and soils,

An important part of the teaching lies in the working out of special problems by the students. Some of the results of this work are worth publication, and a number of them have found record in the bulletins of the experiment station. Some topics now under consideration by horticultural students are these :

The influence of the mechanical texture of soils upon plants under glass; the evolution of the cultivated begonias; the relation of pollen bearing to the vigor of the plant; the relation of flower bearing to the vigor of the plant; the cultivated species of oxalis; the physics of greenhouse roofs; influence of crossing upon the resulting fruit; can acquired characters persist? the evolution of the current chrysanthemums; the philosophy of the watering of plants; the year's rewards in sweet peas; the viburnums as horticultural subjects.

The study of some of these subjects extends over a period of two or three years, and an effort is made to place all available material within the student's reach. The general plan of study is the monograph. In a study of the canna there were brought together nearly 300 varieties; of sweet peas, 120 varieties; of chrysanthemums, from 100 to 200 varieties. It is thus possible to arrive at a comprehensive judgment of the merits and evolution of the varieties, and the educational value of such work is great.

All this is work which demands a considerable maturity of judgment and much training on the part of the student. The reader will now want to know who these students are. In the first place, it should be said that they are few. This teaching is new and it has not yet secured for itself any recognition amongst the traditions of education. It is one of the most recent developments of the modern impulse which aims to carry the educational method into every realm of thought and industry. It must be of slow growth; it must overcome much

prejudice, and it must prove its right to exist. The roster of a single class, that in the evolution of cultivated plants and which is by no means the largest one; may satisfy the reader's curiosity. Fourteen students are at present taking the course. One is a professor of horticulture in a New England State institution and holds the degree of Master of Science; another holds the degree of Bachelor of Arts from the University of Michigan; another is a graduate of the Michigan Agricultural College; two are graduates of Cornell, one of them from the College of Mechanical Engineering and who has a love for rural life as well as for mechanical pursuits; one is the son of a leading Eastern seed merchant, who expects to enter his father's business; one has been a florist for fifteen years and has had training in two universities; two are Japanese; the others are special students who expect to follow rural occupations. Most of these men are fitting themselves for teachers or experimenters and have already reached years of maturity.

Aside from this class of students there are others direct from the farms who are crowding much special and technical work into a brief time. They find their places chiefly in the applied courses, as pomology, propagation of plants and the like, and at work in the gardens and forcing houses. They return to the farms when they have done with their college work. The total number of persons receiving instruction of the horticultural department during the year has been between sixty and seventy for the past two years. These are *bona fide* agricultural students, having come up to the University for the specific purpose of receiving instruction in the College of Agriculture.

EXTENSION TEACHING.

The teaching of agriculture is now indelibly associated with the distribution of the published results of research or experi-

ment work and with the giving of instruction before farmer's meetings. The itinerant teaching has been connected chiefly with the Farmers' Institute movement, which is now firmly established as a governmental enterprise in most of the Northern States. In New York, however, the movement has ripened into a custom of holding itinerant schools which shall be devoted to the particular interests of the locality in which they are held. Itinerant dairy schools have been held in this State, off and on, for a number of years. The first horticultural school of this type ever held was convened in Fredonia, Chautauqua County, New York, in the Christmas holidays of last year (1894). It extended over a period of four days. The underlying conception of the school was to give instruction in some of the fundamental principles of soil tillage and to awaken the enthusiasm of the participants. A system of observation teaching was introduced. A session was opened, for example, by putting leafless twigs into the hands of the students and requiring them to look at the specimens. It is needless to say that many original and novel observations were made, and that curiosity and enthusiasm reached a high pitch when some one stumbled on to the fact that the buds are arranged in geometrical order! These simple observation lessons have always been a source of delight to the participants in these classes, and they have probably resulted in quite as much ultimate good as the more didactic teaching. The students who enroll themselves in these schools are men and women of various ages, comprising persons who love rural life. The enrollment has run from 30 to 120 persons, but the teaching, having been given to the most intelligent persons in the community, exerts a very wide and abiding influence.

As a matter of contemporary interest and of history, the program of this first horticulture school is here inserted :

WEDNESDAY, DEC. 26, 1894.

2 P. M.

1. Announcements.
2. Observation upon *Twigs*.
3. *How Plants live and grow*; with demonstrations with the microscope: W. W. ROWLEE, Assistant Professor of Botany in Cornell University.

7 P. M.

4. *An Analysis of Landscapes*; with stereopticon views: L. H. BAILEY.

THURSDAY, DEC. 27.

9:30 A. M.

5. Observations upon *Fruit Buds*.
6. *The Nursery*; discussion upon the propagation of plants, illustrated with the operations and nursery-grown specimens: NELSON C. SMITH, Geneva.

2 P. M.

7. Observations upon *Seeds*.
8. *A Brief of the Evolution of Plants*; origination of varieties; philosophy of domestication and pruning: L. H. BAILEY.

7 P. M.

9. *The Geological History of Soils*; with stereopticon views: R. S. TARR, Assistant Professor of Dynamic Geology and Physical Geography in Cornell University.

FRIDAY, DEC. 28.

9:30 A. M.

10. Observation upon *Leaves*.
11. *Chemistry of the Grape and of Soils*: G. C. CALDWELL, Professor of Chemistry in Cornell University.

2 P. M.

12. Observation upon *Flowers*.
13. *Theory of Tillage and Productivity of Land*: I. P. ROBERTS, Director of the College of Agriculture, Cornell University.

7 P. M.

14. *What are Fungi?* Considered with special reference to the grape, with stereopticon views: E. G. LODEMAN, Instructor in Horticulture in Cornell University.

SATURDAY, DEC. 29.

9:30 A. M.

15. Observation upon *Fruits*.
16. *Commercial Grape Culture in Chautauqua County*; considered in various aspects: by S. S. CRISSEY, Fredonia; G. SCHOENFELD, Westfield; J. A. TENNANT, Ripley.

2 P. M.

17. Observation upon *The Apple*.
18. Continuation of No. 16.
19. General Question Box.
20. Final exercises.

"This is probably the first school of its kind devoted to horticulture in this country. With no pre-

cedents to guide us we shall probably make mistakes, but we shall all do our best. It will always be a pleasant memory that we have participated in a pioneer movement.

"The day exercises will aim at specific instruction in particular subjects. The evening exercises will be popular illustrated lectures.

"Everyone is invited to attend the various exercises. Persons have the privilege of enrolling themselves as students for the purpose of receiving personal aid upon the points under discussion. At the close of each day's exercise the students will be questioned upon the subjects. This questioning is not pursued for the purpose of ascertaining the student's knowledge of the exercise, but to elucidate the subject under discussion. During this exercise, also, the student has the privilege of freely asking questions upon the topic under consideration. It is expected that the instructors will not be interrupted with questions during the course of the exercise.

"Each day session will be opened with a *lesson upon observation*. Students will be given specimens, as indicated in the program, and ten minutes will be allowed for examination of them. The students will then be questioned as to what they have seen.

"Students should provide themselves with notebook and pencil.

"Roll will be called immediately upon the hour set for meeting.

"Printed synopses of all the day lectures will be distributed to students.

"While most of the instruction deals with fundamental principles, special applications will be made to the grape whenever possible."

About a dozen of these schools, of longer or shorter duration, have now been held. They always awaken a widespread influence. Frequently the residents of the village or city attend them in the interest of nature study. In Jamestown, a city of 20,000 people, the high school was dismissed upon one occasion to enable the teachers to attend an observation upon flowers. It is certain that these schools accomplish more direct good for the farming interests by means of this type of teaching than they could by simply specifying a set of rules which the farmer shall follow, or by giving up the time to so-called practical information. This teaching not only awakens the farmer himself, but it also interests all

other citizens in his work. All this was never better illustrated than in a session at the Jamestown school devoted to insects. If one is to talk to a rural audience about insects it is presumed, of course, that he will devote himself to methods of destroying them. Not so here, however. Insects were passed around for observation, and *papier maché* models were in the hands of the instructor. The teacher soon had the audience interested in the insect itself. The students looked through the bug's eyes, heard as it heard, felt as it felt, and thereby came into sympathy with living things. For nearly two hours over one hundred people listened to this exposition in rapt attention, and it is safe to say that every student went away in a wholly new frame of mind respecting the objects which he had always been taught to dread.

EXPERIMENT OR RESEARCH WORK.

Aside from all this extension teaching, the experiment station publications must not be overlooked. Each State and Territory is in recent years issuing these periodical bulletins of instruction and information, and the effect is even now seen in the beginnings of an uplift in the agricultural population of which the outcome, at the end of the present generation, will be momentous and stupendous. Probably no government has ever inaugurated a movement which reflects more wisdom and statesmanship upon its promoters than this experiment station enterprise of the United States. It probes the very essence of national prosperity and lays a foundation of intelligence and inspiration which all the convulsions of time cannot overturn.

At Cornell the experiment station work has attempted to consider fundamental subjects, or those of abiding interest, rather than those of mere transient or local importance. Our horticultural inquiries have lain along three lines: the study of the

fruit interests of the State; the study of the forcing-house industry, particularly in relation to winter vegetables and the commercial flowers; studies in the systematic botany of cultivated plants. Many of the results have been published in bulletins of the experiment station. In the forcing industry we need soon to take up the growing of winter fruits, such as nectarines, peaches, cherries, grapes and the like, subjects for which we at present have no equipment. The influence of the electric light upon plants has been a subject of study for five consecutive years.

My reader now wants to know if the farmer appreciates it all. For New York State, I answer, Yes! A thousand times, Yes! Those who have kept no track of the farming population can have no appreciation of the almost volcanic awakening which is now taking place. Old methods are breaking down, old and cherished customs are crumbling, and in the confusion of the break-up and the transition the weak are going to the wall; but the best will survive! Rural life is the life of the future. Its inspiration and support are the irrevocable laws which are an inborn and integral part of the constitution of nature and of society.

The old and deserved derision of 'book-farming' is only a memory. Good teaching finds a response everywhere. In fact, the response is the measure of the teaching. The college professor is not only welcome, but is eagerly sought in almost every rural community. There is direct proof of this interest in New York State. The funds upon which we, at Cornell, are able to hold these schools and to make many investigations upon the farms were given by the State Legislature in response to a spontaneous demand from the people without any aid or abetting by teachers or experimenters.

UNSUPPLIED DEMANDS.

In purely horticultural directions the

demands for better facilities of instruction are urgent. One of the chief of these demands is in floriculture and other glass-house industry. This is the refinement of rural industry, and it becomes prominent with the progress and refinement of the state. Floriculture is preëminently adapted to the employment of women, both upon the side of plant growing and upon the side of decoration and adornment. The value of the floricultural product in the last census year was over \$26,000,000, and 2,000 women were then employed in the business. The enumeration of floriculture in the eleventh census, which was the first one ever made in this country, is said to have been suggested by Mrs. Porter, wife of the Superintendent of the Census, and originated in her desire to find employment for the many women who applied to her. All this great and growing floricultural and glass-house industry has no school which it may call its own, and none which is giving any specific attention to the subject. It is doubtful if any other industry of equal extent in the country is so completely without the means of education. The only way to become a florist now is to 'serve time' in an establishment. This the women, at least, can not do; but if there were a school where, in connection with good educational facilities, the art and practice and science of floriculture were taught, women as well as men could find an attractive outlet for their ambitions. The time cannot be far remote when some institution will honor itself with a school of floriculture.

In conclusion, the reader should be reminded that it is a fundamental concept of modern society that educational facilities shall be extended to every person. There must be a general intellectual uplift. Almost every profession and class of persons have been reached by this widening educational impulse, but the farmer and the horti-

culturist have been touched the least of all. These rural pursuits are particularly difficult to reach, not because the people who follow them are unwilling to learn, but because most of the instruction has been out of sympathy with them and unadapted to them. The more difficult the problem, the greater is the need of solving it. The rural industries must be enlightened by instruction which shall be both educational and useful. Nothing less can satisfy the demands of humanity and patriotism.

L. H. BAILEY.

ON SCHOOL HYGIENE.*

HYGIENE is applied physiology. It is the science and art of promoting and preserving health, which we take to mean the greatest energy of each part, compatible with the greatest energy of the whole organism. School hygiene as an art is concerned with all measures that science and experience have shown to be helpful and efficacious for securing the normal growth and development of pupils and the normal activity of teachers, under the conditions incident to school life. Nearly one-quarter of the total population of the United States is at present subject to the conditions of school life, or, in other words, is engaged in the sedentary occupation of schooling. Of our school population over 96% is found in elementary schools, and over 18% is found in cities. Urban conditions at their best are less favorable than rural conditions for rearing full-grown, vigorous, healthy children. City-bred children of school age in America—at least in the six great cities on the Atlantic seaboard—are less favorably situated than their contemporaries in certain European cities, it would appear.

Thus the death rate per 1,000 living at

the age-period 5-15, which is the healthiest decade of life among civilized men, is less in London than in Brooklyn, Philadelphia, New York, Washington and Baltimore, or in Boston, whose death rate is higher than in any of the cities named, while Berlin has a lower death rate than any of these cities, except Washington and Baltimore. The mortality from diphtheria among children of school age—and from consumption among female school teachers—is markedly greater in Boston than in any other of the American cities named above. No class of wage earners in Boston, so far as the mortality rates, analyzed by occupation, of the U. S. Census Bureau go, has so high a death rate from consumption as women school teachers, excepting marble and stone cutters. The fact that Boston is the only one these six cities which habitually neglects to wash her schoolhouse floors and corridors from year to year and decade to decade is not without significance.

It cannot be denied that municipal sanitation and school hygiene are more highly organized and successfully administered in the leading cities of Europe than in the leading cities of America. Indeed, school hygiene had no place or standing among the arts and sciences in America. There appears to be no department of public health so miserably endowed, so incompletely organized, or so wellnigh universally neglected by publicists, scientists and publishers as school hygiene. Without resorting to foreign books, periodicals and official reports, it is quite impossible for the student to inform himself as to the nature and results of the investigations and experiments made during recent years for the improvement of the health of the school population on the continent of Europe.

The public schools are organized, maintained and regulated by the State, which clearly owes it to itself to take adequate measures to prevent the school population

*Abstract of report of Chairman of Committee on School Hygiene—read before child-study section of National Education Association, at Denver meeting, July, 1895.

from contributing to the spread of epidemic diseases and thereby endangering the public health. It is also the duty of the State, particularly where attendance in school is compelled by law, to provide schoolhouses so placed, arranged and furnished that their occupants, both pupils and teachers, shall not be subjected to insanitary influences, or allowed to engage in unhygienic procedures in prosecuting their work. School boards as at present constituted, and teachers as at present trained for their profession, are unequal to organizing or administering a genuine and effectual system of school hygiene, such as the times demand in city schools. Experts in medicine, sanitation and hygiene are necessary, nay, indispensable for such a purpose.

If the public health is to be effectually guarded, the schools and those that frequent them should be subject to the inspection by properly trained representatives of the Board of Public Health, which board should have a voice in the selection of school sites, and in matters relating to the drainage, plumbing, heating, lighting and ventilation of schoolhouses. Ordinary physicians and teachers are not competent, as a rule, to pass intelligently upon questions of sanitary engineering which naturally arise in connection with the planning, erecting and furnishing of schoolhouses. Sanitarians, architects and hygienists should settle these and kindred questions. Even then there is room left for a special inspector or director of school hygiene, whose business it should be to see that teachers and janitors carry out such reasonable rules as may be laid down (with regard to the hygiene of the school, the class-room and the hygiene of the school child) by public health officers, sanitary experts and school officials acting together. The teachers should be made thoroughly conversant, during their professional training, with the hygiene of instruction and be required to conform to its prin-

ciples in all practices and procedures which affect the eyes, ears, brains, muscles or bones of their pupils. These three classes of experts acting together could regulate the gymnastics and plays, hours of study, methods of instruction, in short, the school life of the children, in the interest of public health, personal hygiene and school efficiency.

The fact that no American university, medical school, technical school or normal school offers such theoretical and practical courses as are requisite for training up experts in school hygiene may be granted. But we submit that this state of things simply serves to emphasize the need of a campaign of education in the interests of hygiene in general and of school hygiene in particular. Let us strive to enlist the aid of physicians, sanitarians, educational authorities and philanthropists in planning and waging such a campaign. The ultimate aim of such a campaign would be the organization and maintenance of a comprehensive and effectual system of medical inspection and hygienic supervision of city schools and their pupils. To bring this about, the electorate must first be enlightened and aroused.

What can we do as members of the N. E. A. to further these ends?

1. We can utilize the literature of school hygiene in making known to the general and educational public the nature and results of European study and experiment.

2. We can urge the necessity of determining, by thoroughgoing investigation, the actual condition of the school population of our great cities, so that intelligent action may be taken to amend the most obnoxious and dangerous features of that condition.

3. We can endeavor to induce some progressive and influential university or technical school to grasp the idea that it would be performing a public service, and possibly enter upon a profitable speculation, if it

were to establish courses of instruction, similar to the best in Europe, for the training of experts in school sanitation and hygiene.

EDWARD M. HARTWELL.

BOSTON, MASS.

A SIMPLE APPARATUS FOR COLLECTING SAMPLES OF WATER AT VARIOUS DEPTHS.

VARIOUS devices have been used for collecting samples of water for bacteriological examination at different depths below the surface of a pond, but few of them are satisfactory. Some are too complicated and liable to get out of order; some are too expensive; some are too fragile for transportation; some cannot be well sterilized; while others have the besetting sin of operating at the wrong time or of failing to operate when required. Realizing the great importance of having a reliable method for collecting samples, the writer, after much experimenting, decided upon the form of apparatus here described.

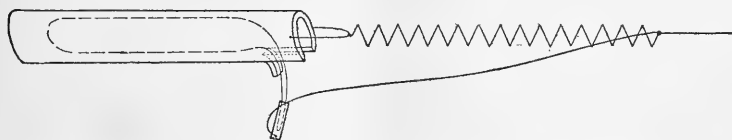

It consists primarily of a glass tube $\frac{3}{4}$ inch in diameter and 5 inches long, closed at one end and having the other end drawn out at right angles and bent downwards as shown in the figure. The air is partially exhausted by means of an aspirator and the end of the tube sealed in the flame.

This vacuum tube is essentially the same as that first recommended by Pasteur, though he obtained his vacuum in a different way.

After being sterilized the tube is placed in the collecting frame, which consists of a piece of lead pipe about seven inches long and having an internal diameter of $\frac{7}{8}$ inch.

At the upper end a strip of the lead is cut out and turned downwards, as shown in the figure, so as to form a rest for the bent arm of the glass tube. The glass tube is held in place either by a stopper pressed into the top of the tube or by a suitable spring clip passing around the bent arm and the projecting strip of lead. The weight of the lead is sufficient to sink the apparatus. A bail at the top of the lead pipe is attached to a spiral spring about eight inches long, which in turn is fastened to the cord or wire by which the apparatus is lowered. To the upper end of the spring there is attached a flexible wire, carrying at its lower end a small brass tube, one inch long, of such a diameter that it will easily fit over the end of the bent arm of the glass tube. The length of the flexible wire and the stiffness of the spring are so adjusted that when the apparatus is suspended by the cord in the water the flexible wire is slack; but when a sudden jerk is given

to the cord the spring stretches so much that tension is brought on the flexible wire and a sudden pull communicated to the bent arm of the tube, resulting in the same being fractured. If the bent arm has previously been scratched with a file the break will be an even one.

The operation of collecting a sample is quite apparent. The glass tube being fastened in its place and the brass cap being put over the end of the bent arm, the apparatus is lowered to the required depth, care being taken that the cord runs out smoothly and without jerking. A sudden jerk is then given to the cord. This breaks

off the end of the bent arm, and the water rushes into the tube to an amount depending upon the completeness of the vacuum and the pressure of the water where the sample is taken. Usually the tube is found to be almost, but not entirely full.

After being drawn to the surface the vacuum tube containing the collected sample is removed from the frame and its end plugged with cotton or sealed with a bit of wax. Even if the end is left open there will probably be little danger of contamination on account of the shape of the tube and the small diameter of the bent arm.

The vacuum tubes may be conveniently transported in an ordinary 'cabin topped' leather bag, which has a tin box inside divided into two compartments, the lower one for ice and the upper one for the tubes which are placed in a suitable rack.

When a tube is to be opened a scratch is made near the bend of the tube with a file or glass cutter and the end knocked off, allowing the admission of a pipette. Both the glass cutter and the outside of the tube should first be sterilized by flaming. It is perhaps needless to say that the sample should be planted immediately after opening the tube.

This apparatus for collecting samples possesses several advantages. It is lowered and operated by a single cord. The whole apparatus may be easily sterilized by dry heat, or the vacuum tubes may be sterilized separately and inserted one after another in the collecting frame. The vacuum tubes are cheap and easily made; they may be transported without fear of breakage. There is practically no danger of contamination of the sample either in collecting, transporting or opening. The apparatus, if properly adjusted, is absolutely sure to operate at the right time and in the manner desired.

In conclusion, it may be said that the method has been used for some time at the

biological laboratory of the Boston Water Works and its results have been uniformly satisfactory. A somewhat similar apparatus, in which a spring and flexible cord were used to open a small valve in the stopper of a bottle, was recently used by the writer at Lake Champlain to obtain samples at a depth of 370 feet. Even at that depth no trouble whatever was experienced.

GEORGE CHANDLER WHIPPLE.

NEWTON CENTRE, MASS.

THE LOBACHÉVSKI PRIZE.

ON May 1, 1895, the Lobachévski Fund had reached, beyond all expenses, 8,840 roubles, 95 kopeks.

This sum permits the accomplishment of the double aim of the committee: to found an international prize for research in geometry, especially non-Euclidean geometry, and to erect a bust of the celebrated scientist. The prize, 500 roubles, will be adjudged every three years to the best works or memoirs on geometry, especially non-Euclidean geometry.

The prize will be given for works printed in Russian, French, German, English, Italian or Latin, sent to the Physico-mathematical Society of Kazán by the authors, published during the six years which precede the adjudication of the prize. Works to compete must be sent to the Society at the latest one year before the day of award, October 22, old style (November 3).

The first prize will be adjudged October 22 (November 3), 1897.

To award the prize, the Society will form a commission to choose judges among Russian or foreign scientists.

The work of the judges (reporters) will be recompensed by medals of gold, bearing the name of Lobachévski.

As a fixed capital to found this prize, 6,000 roubles were invested.

Of the sum collected, an additional 2,000 roubles goes to share the expense of erect-

ing a bust of Lobachévski in the park bearing his name in front of the University edifice in Kazán, the remainder of the cost to be borne by the Municipal Council.

A special committee, consisting of representatives of the Municipal Council and of the Physico-Mathematical Society, has made a contract with Mlle. Dillon, who engages for 3,000 roubles to furnish a bronze bust of Lobachévski, to be placed on a granite pedestal, the height of the monument to exceed 3 mètres.

It is hoped to unveil the bust between the 15th and the 25th of September, 1896.

This 'fête mathématique' will follow the 'congrès des savants russes naturalistes et mathématiciens' at Kiev from 1st to 12th of September, 1896, and be during the grand Russian Exposition artistic and industrial at Nijny-Novgorod in the summer and autumn of 1896. Foreigners in any way identified with the name of Lobachévski are invited to the fête, and such as accept will be the guests of the city and University of Kazán.

For a second bust of Lobachévski to be placed in the Assembly Hall of the University, 200 roubles have been given from the Lobachévski fund, the remainder of the cost to be borne by the professors of the University.

The remainder of the sum already collected (640 r., 95 k.) will be added to the fixed capital. The augmentation of the capital will permit of a new edition of Lobachévski's works in a few years, the first volume of the Kazán edition having already become rare (out of print).

The Physico-mathematical Society of Kazán has already received a large number of works and memoirs relating to Lobachévski and non-Euclidean geometry, and now having added its own collection of the printed and manuscript works of Lobachévski, the Society has inaugurated a separate library under the name *Bibliotheca Lobachévskiana*.

It is hoped that in time this library will collect all the literature of non-Euclidean geometry and be an indispensable aid to those engaged in its development.

All writers on this fecund subject are begged to send to this library copies of their works.

Alas! That the Mathematico-physical Society of Hungary, a country having an equal claim to all the honors of the non-Euclidean geometry through the genius of Bolyai János, should have been content with placing in 1894 a monumental stone on his long neglected grave in Maros-Vásárhely! GEORGE BRUCE HALSTED.

AUSTIN, TEXAS.

AMERICAN SOCIETY OF MECHANICAL ENGINEERS.

THE sixteenth annual convention of the American Society of Mechanical Engineers was held December 3d to 6th, inclusive, in New York, at the house of the Society, No. 12 W. 31st St., the old home of the Academy of Music. The program included the presentation of 13 papers, mainly by members of the faculties of various schools of mechanical engineering, although the most notable papers were, perhaps, usually those of well-known practitioners. Many interesting and instructive 'topical discussions' took place also; and these usually brought out the most extended debates.

The papers of Messrs. McElroy and Weber were devoted to the discussion of the extent, availability and probable costs of power derivable from the Caratunk Falls on the Kennebec and the subject 'Water Power; its Generation and Transmission,' and were rich in valuable data and statistics of immediate use to the engineer and hydraulician. Mr. Emery gave a brief account of his work of rearranging the machinery and apparatus of a great oil refinery at Bayonne, by improving which he had saved already 32,000 tons of fuel *per annum*,

and is still effecting further gains. The methods adopted involved extensive utilization of exhaust steam and a limited application of electric power distribution. This was the most striking and suggestive paper of the week. The same writer discussed 'Comparative tests of Steam Boilers with different kinds of Coal;' showing that much uncertainty still exists in regard to the exact calorific value of the various elements of the fuels, and their mutual influence as burned in the fire-box of the steam boiler, and also in regard to the relation between the results of test in that manner and those obtained by the use of the various 'calorimeters,' bomb and other. The earlier work of Mr. Kent was the basis of the discussion largely.

Prof. Kingsbury's account of his experiments upon the friction of screws, by use of an ingenious and well-designed automatic apparatus of his own construction, interested the convention and gave rise to considerable discussion. Carrying pressures up to 10,000 and to 14,000 pounds on the square inch, he found coefficients ranging from three to twenty-five per cent., but showed that moderate values could be secured by the combination of proper metals in well-proportioned and accurately-formed journals and bearings. He proved that the heavy mineral oils, and especially those to which a small amount of graphite had been added, were best. With the latter a coefficient as low as three per cent. had been obtained. The testing apparatus was a modification of Prof. Thurston's oil-testing machine, in which the tremendous pressures on the square-threaded screws employed were carried in such manner as not to cause appreciable inaccuracy.

Prof. Goss described tests of the DeLaval Steam-Turbine, giving the horse-power hour on about fifty pounds of steam, a figure far above that usually claimed for that class of machine, and three times as

high as the reported best record. Prof. Bissell described an ingenious recording device for testing machines and Prof. Carpenter discussed Sibley College experiments on the effects of heat upon strength of iron and steel; effects which were stated, in the course of the discussion, to have been also shown in the course of the more extended experiments of German investigators.

Prof. Barr's paper on the proportions of high-speed engine summarized his work in comparison of the proportions adopted by the principal builders, and showed that their practice covered a wide range, but that the best grouped themselves about the mean rather closely. Constants were thus introduced into the rational formulas of strength of materials by the author of the paper, which were representative of the extremes of practice and of the mean, which latter are presumed to serve as a good guide in general practice. This paper attracted much attention as being a first step in the direction of reduction of the vagaries of ancient practice to a reasonable and economical basis. Its author announced that he had already commenced a similar analysis of current practice, in the proportioning of the 'low-speed' engine.

Many other papers and discussions, which cannot be here noticed, contributed greatly to the instruction and profit derived from the convention. All will appear in the next volume of the transactions. The attendance was large, about one fourth the total membership. The Society, organized in 1880, now numbers about 1750 members and includes substantially all of the leading members of the profession. A novel and important feature of the convention was the appointment, at the request of the Superintendent of Buildings, of a committee to cooperate with architects and representatives of the building trades in the revision and improvement of the building laws. The newly elected President is the

distinguished iron master, John Fritz, the builder and manager of the famous Bethlehem Iron Works.

CURRENT NOTES ON ANTHROPOLOGY (XV.).

THE PITHECANTHROPUS ERECTUS.

IN SCIENCE, January 11, 1895, I published the first notice, in this country, of Dr. Dubois' remarkable find, in Java, of a creature intermediate between man and the apes; adding that his monograph could not fail to excite wide attention. This was so decidedly the case, so many articles appeared for and against the accuracy of his statements and conclusions, that the Dutch government sent for him to come in person and bring all his specimens to the International Zoölogical Congress in Leyden, in October last. He punctually appeared, with a large number of mammalian bones from the formation in which the Pithecanthropus was found, and an additional tooth of the animal itself.

The geological experts present decided that the various bones indicated the oldest pleistocene or else the youngest pliocene. The anatomists expressed themselves about the skull, teeth and femur of the alleged 'missing link.' Professor Virchow, probably the most conservative, maintained that the bones were of an ape; but an ape generically distinct from any known; and if the skull and femur belonged to the same individual then it was an erect ape, walking like a man; but he would not acknowledge that it bridged the gap between the anthropus and the anthropoid.

Practically the same result was reached by the eminent French anatomist, Dr. Manouvrier. He studied the originals in the possession of Dr. Dubois; and he declares there can be no doubt that in them we see the remains of a creature intermediate between man and the ape, walking erect, with a cranium like that of the gibbons, but much larger than any existing gibbon.

The conclusion is indisputable that in the Pithecanthropus we have an animal higher than the highest ape and lower than the lowest man.

AFFINITIES OF THE CHACO LANGUAGES.

DR. S. A. LAFONE QUEVEDO, well known for his studies of the native tongues of the Argentine Republic, has lately published some of his results in a paper entitled 'Las Migraciones de los Indios en la America Meridional.' The theory he advocates briefly is that the Kechua, the Aymara, the Araucan, Cacan, Guaycuru and Guarani are fundamentally much less different than has been supposed; that, allowing for phonetic changes, and adventitious and local forms, they have so much underlying similarity that we should regard them as developments from a common, ancient speech. To support this opinion, he lays much stress on the words for water, river, rain, etc., and on the personal pronouns.

Much more evidence will have to be presented before this opinion will be accepted. It is in conflict with the views of nearly all previous scholars. On the other hand, all will welcome the special studies of the same writer on the Chaco dialects. He has in press an extended grammar of the Abipone, and is engaged on another of the Mbaya and a third of the Payaguá. He has reached the conviction that the Vilela and Lule are the only two non-Guaycuru languages in the Argentine Chaco. If this is so it simplifies amazingly the extremely complicated ethnography of that region.

D. G. BRINTON.

UNIVERSITY OF PENNSYLVANIA.

SCIENTIFIC NOTES AND NEWS.

ASTRONOMICAL.

MEASUREMENT of the photographic plates taken for the purpose of making an accurate catalogue of all the stars in the heavens has decidedly gone beyond the preliminary stage.

From the last number of the *Vierteljahrsschrift der Astronomischen Gesellschaft* we learn that during the year 1894, 46 plates, containing 11,750 stars, have been measured at the Potsdam Observatory. At Paris, where measurements have been going on for two years, the number of star positions obtained is as follows, according to the reports of M. Tisserand, Director of the Paris Observatory:

In 1893, 27,750 stars, from 72 plates.

In 1894, 32,898 stars, from 120 plates.

ONE of the most extensive least square solutions ever made has recently been published by Prof. Schur, of Göttingen. The heliometric triangulation of the stars in the cluster *Præsepe* gave rise to a series of 74 normal equations, involving 74 unknown quantities. The solution of this set of equations was effected by Prof. Schur in ten weeks, by means of the usual Gaussian method of elimination. Prof. Schur comes to the conclusion that no other method of elimination, such as the method by successive approximation, is to be compared to the Gaussian method, even though it might seem to promise a saving of labor in advance. Prof. Schur mentions as the longest least square solution he has been able to find in astronomical literature a geodetic adjustment made by Bayer, in which a set of normal equations with 86 unknowns was successfully solved by the famous computer Dase in three months.

H. J.

BIBLIOGRAPHIES OF THE SCIENCES.

RECENT numbers of the *Revue Scientifique* (Nov. 9, 16 and 23) contain important articles in regard to action taken by the scientific congresses on bibliography. A recommendation adopted by the French Association, the Berne Physiological Congress and the Brussels Bibliographical Conference proposes that the most significant word in the title of a scientific paper be indicated by a line printed under it and extending the whole length of the word, and that subdivisions of the subject treated be indicated by words in the title with lines printed underneath one-half the length of the word.

The International Bibliographical Conference, held in Brussels during September, has established an *Office internationale de bibliographie* at

Brussels, and has requested the Belgian government to take the initiative in securing the coöperation of other governments in the support of an international bureau. The conference recommended without hesitation a decimal system of classification, and after some discussion the adoption of the Dewey system in its present form. The Physiological Congress, however, decided that careful consideration would be necessary before a system of classification could be finally adopted, and a committee was appointed, with instructions to report at the next Congress, consisting of Profs. Bowditch, Foster, Kronecker, Mosso and Richet.

It is to be feared that underlining the significant words in a title will cause difficulties to authors, editors and printers. When a title is properly chosen all the leading words should be significant and are likely to be nearly equally so. If a decimal classification of the sciences could be agreed upon, the object desired could be secured by requesting the author to indicate after the title what he regards as the proper classification of his article.

THE ANNIVERSARY MEETING OF THE ROYAL SOCIETY.

AT the Anniversary Meeting on November 30th, at Burlington House, the reports of the officers of the Society were presented and the following officers were elected for the ensuing year:

President, Sir Joseph Lister; Treasurer, Sir John Evans; Secretaries, Prof. Michael Foster, M. D., and Lord Rayleigh; Foreign Secretary, Dr. Edward Frankland; other members of the Council, Mr. William Crookes, Sir Joseph Fayrer, Mr. Lazarus Fletcher, Dr. W. H. Gaskell, Dr. W. Huggins, Lord Kelvin, Prof. Alexander B. W. Kennedy, Prof. Horace Lamb, Prof. E. R. Lankester, Prof. Charles Lapworth, Major P. A. MacMahon, R. A., Prof. J. H. Poynting, Prof. A. W. Rücker, Mr. Osbert Salvin, Prof. H. M. Ward and Admiral W. J. Lloyd Wharton.

The Copley Medal was awarded to Dr. Karl Weierstrass, distinguished for investigations in pure mathematics extending over a period of fifty years. A Royal Medal was awarded to Dr. John Murray for his editorship of the report

of the Challenger Expedition and for his own large contributions to the work of the expedition, and to the scientific papers embodied in the report. A Royal Medal was awarded to Prof. J. A. Ewing for his investigations on magnetic induction. The Davy Medal was conferred on Prof. William Ramsay for his work on argon and helium.

Lord Kelvin, who retires at his own request from the presidency after five years of service, delivered an admirable anniversary address, reviewing the scientific events of the preceding year in so far as they relate to the Royal Society. After paying tributes to the memory of Cayley, Neumann, Huxley and Pasteur, he described the progress that had been made in regard to cataloguing scientific papers, the centenary of the French Academy, and other matters. He concluded by describing in some detail the work of those on whom the medals were conferred.

PROGRAM FOR THE PHILADELPHIA MEETING OF
THE AMERICAN SOCIETY OF NATURALISTS.

Thursday, December 26th, 2 P. M.

1. Reports of Committees.
2. Special Reports.
3. Recommendation of new members.
4. President's Address: 'The Formulation of the Natural Sciences.'

8 P. M.

Illustrated lecture at the hall of the Academy of Natural Sciences, corner of 19th and Race Streets, by Prof. W. B. Scott, of Princeton University, on 'The American Tertiary Lakes and their Mammalian Faunas.'

9 P. M.

Reception to all the Societies given by Prof. Horace Jayne, at his home on the southeast corner of 19th and Chestnut Streets.

Friday, December 27th, 9 A. M.

1. Election of new members.
2. Election of new officers for 1896.
3. Other business that may arise.

10 A. M.

Discussion. *Subject:* 'The Origin and Relations of the Floras and Faunas of the Antarctic and Adjacent Regions.'

Geology: PROF. ANGELO HEILPRIN, Philadelphia Academy Natural Sciences.

Paleontology: PROF. W. B. SCOTT, Princeton University.

2 P. M.

Botany: PROF. N. L. BRITTON, Columbia College.

Zoology. Invertebrata of the Land: PROF. A. S. PACKARD, Brown University.

Zoology, Vertebrata of the Land, Fishes, Batrachia and Reptiles: DR. T. N. GILL, Smithsonian Institution.

Zoology. Vertebrata of the Land, Birds and Mammalia: MR. J. A. ALLEN, American Museum Natural History, New York.

Zoology. Vertebrata of the Sea: DR. G. BROWN GOODE, U. S. National Museum.

The maximum time permitted to each speaker is 30 minutes. General discussion at the close.

7:30 P. M.

Annual Dinner of the Affiliated Societies at the Lafayette Hotel, northwest corner of Broad and Sansom Streets.

GENERAL.

THE *Journal of Experimental Medicine*, a periodical to appear at least four times a year, will be published at the beginning of the year by D. Appleton & Co. The journal, which is to be devoted to original investigations in physiology, pathology, bacteriology, pharmacology, physiological chemistry, hygiene and medicine, will be edited by Professor William H. Welch, of Johns Hopkins University, with a board of twelve associate editors, as follows: For physiology: H. P. Bowditch, Harvard University; R. H. Chittenden, Yale University; W. H. Howell, Johns Hopkins University. For pathology: J. George Adami, McGill University; W. T. Councilman, Harvard University; T. Mitchell Prudden, Columbia College. For pharmacology: John J. Abel, Johns Hopkins University; Arthur R. Cushny, University of Michigan; H. C. Wood, University of Pennsylvania. For medicine: R. H. Fitz, Harvard University; William Osler, Johns Hopkins University; William Pepper, University of Pennsylvania.

THE Third Annual Congress of Teachers of Chemistry will be held in the Kent Chemical Laboratory of the University of Chicago, on Monday, December 30, at 2:00 P. M., and on Tuesday, December 31, at 9:00 A. M. The following subjects will come up for discussion in the order named: (1) Report of committee (Messrs. Freer, Noyes and A. Smith) on reasons why the study of physics should precede that of chemistry in the high schools. (2) Report of committee (Messrs. Freer, Swan and Linebarger) on a detailed outline of study of chemistry for the secondary and high schools. (3) Which method—the lecture, or the text-book system—is, on the whole, the most advantageous to use in teaching chemistry in the colleges? (4) Mendelejeff's periodic law; its place and its function in an elementary (say one year's course) in chemistry? (5) To what extent should physical chemistry be introduced into a course in college general chemistry? There will be no set papers read and the discussion will be entirely informal. Every teacher of chemistry in a high school or a college will be welcome and is invited to be present, no special invitation being necessary.

THE *Astronomischen Gesellschaft* has decided, because of the expense connected therewith, no longer to maintain a library. The announcement is made that the Society does not desire to receive any publications in the future and that, with the completion of the 30th year of the *Vierteljahresschrift*, no exchanges with other scientific bodies will be continued.

DURING the winter of 1876-77, the cormorants of the Commander Islands, *Phalacrocorax pelagicus*, were almost exterminated by an epidemic, dying in such numbers that the beach was strewn with thousands of dead birds. They recovered from this and by 1882 were again abundant, although by no means as plentiful as before. Dr. Stejneger reports that the species has again suffered from the ravages of disease and the cormorants are now exceedingly rare where they formerly abounded.

THE U. S. Geological Survey, and its officers, were awarded several gold medals and as many diplomas at the Atlanta Exposition, for the instructive, interesting and admirably installed

exhibits that it placed there. There is a grand prize and a gold medal for the exhibit of relief maps, etc., a medal and diploma for the Chief Chemist of the Survey, Prof. F. W. Clarke, in 'grateful recognition' of his services in the installation of various exhibits, and a grand prize and gold medal to Dr. D. T. Day, of the Survey staff, for a study and exhibit, made with the cooperation of the Exposition Company, of the mineral resources of the South.

A MARK of the high esteem in which the work of the Geological Survey is held abroad has just been received by the Director. The recent Exposition of Mining and Metallurgy, held at Santiago, Chili, awarded the Survey the first premium for the Geologic Atlas of the United States and a collection of its publications. The maps and reports referred to constituted virtually the whole exhibit of the Survey at Santiago.

A NEW Russian medical journal, *Russisches Archiv für Pathologie, Clinische Medizin und Bacteriologie*, will be published monthly after January next. It will be edited by Prof. W. W. Podewyssotzky, of Kieff.

THE Secretary of the Royal Malacological Society of Belgium, Prof. Hugo de Cort, 47 Rue Veydt, writes us that he wishes to arrange exchanges of Belgian for foreign shells.

THE eleventh annual meeting of the Indiana Academy of Sciences will be held in Indianapolis on Friday and Saturday, December 27th and 28th. The State has undertaken the publication of the proceedings of the Academy.

It is expected that the Astronomical Observatory of the University of Berlin will be removed to Dahlem, to which suburb, as recently stated in this journal, it is proposed to remove the Botanical Garden.

SURGEON-MAJOR DOBSON, F. R. S., died on November 26th, at West Malling. He was the author of numerous original researches in Zoology and comparative Anatomy.

THE Argentine Medical Club of Buenos Ayres offers three prizes, the first of \$300 for researches in bacteriology, to be presented before May 31, 1897. The prizes are offered to honor the memory of Pasteur.

In spite of the anti-toxin treatment, the epidemic of diphtheria in London continues; the number of deaths during the week ending November 30th was 63, which is 24 more than the average for the previous ten years.

DR. DONALDSON SMITH, who left England in the Summer of 1893, with the object of exploring Lakes Budolph and Stephanie, has just reached Plymouth, England. Since February nothing had been heard of him, until a telegram from Aden, at the beginning of November, announced the success of the expedition, and the arrival of Dr. Smith at that place. Dr. Smith will read a paper before the Royal Geographical Society next month, and in January will return to America, where an account of his travels will be published.

THE late Professor Verneuil is succeeded in the Paris Academy of Sciences by M. Lannelongue (who received 36 votes, while M. Ollier received 22), and in the Paris Academy of Medicine by M. C. H. Monod.

THE new anatomical and physiological laboratories of the University of Glasgow were opened on November 18th.

The *Lancet* states that the Royal College of Physicians of Edinburgh has purchased, at a cost exceeding \$35,000, property on which a laboratory will be erected.

SIR HENRY ACLAND was presented, on December 4th, with a testimonial to commemorate his services during the forty years for which he has held the office of Regius professorship of medicine in the University of Oxford. A bust will be placed in the University Museum and over \$15,000 will be given to the Sarah Acland home for nurses.

WE announced last week the death of Henry Seebohm, one of the most eminent and best known of British ornithologists. Mr. Seebohm was an explorer as well as an ornithologist, and his delightful volumes '*Siberia in Asia*' and '*Siberia in Europe*' brought him a wide circle of readers. Among the best known of his bird books are '*A History of British Birds*' (3 vols.), '*Monograph of the Plovers, Snipes and Sandpipers*' and '*Birds of the Japanese Empire*.' Several of his works are richly illustrated by colored

plates. Seebohm followed no leader, and his numerous writings are always vigorous, interesting and original. Personally he was genial and generous, and his death will be sadly felt on both sides of the Atlantic.

WE regret to record the death of the Rev. Timothy O. Paine, a well known Egyptian scholar, on December 6th; of Professor W. N. Popoff, lecturer on physiology in the University of Dorpat, and of Dr. G. Krabbe, of the University of Berlin, on November 3rd, at the age of 80 years.

LORD KELVIN in his anniversary address before the Royal Society described the steps that have been taken towards the publication of an index of scientific literature. Through a gift from Mr. Ludwig Mond, F. R. S., \$10,000 is available for the expenses of cataloguing, and there are now twelve copyists engaged in the work. About 140,000 slips have been mounted and classified. Lord Kelvin referred to the International Institute of Bibliography established in Brussels, but says that this will not interfere with the International Conference to which invitations have been issued for July of next year.

IN view of the approaching quinquennial census to be taken in 1896 in both France and England, it is interesting to compare the population of the two countries. In 1801 France possessed a population more than eleven millions greater than Great Britain and Ireland, whereas in 1891 the excess of population in France was less than one-half million. It is probable that the population of the United Kingdom is now the greater. In the two years 1892 and 1893 the deaths outnumbered the births in France, whereas in the United Kingdom there were nearly a million more births than deaths.

EDUCATIONAL NOTES AND NEWS.

MISS HELEN CULVER signed papers on December 14th giving \$1,000,000 to the University of Chicago to be used for the biological departments. This gift carries with it \$1,000,000 conditionally pledged by Mr. John D. Rockefeller on November 2d. It is probable that a school of medicine will be established.

THE *Academische Revue* states that the University Extension Movement in connection with the University of Vienna is meeting with much success. The first courses now being given number twenty-four, and in the first week 1,916 auditors were registered. The largest attendance (350) is in the course in anatomy, offered by Prof. Zuckerkandl. Each course is composed of six lectures, and the fee for attendance on the course is only about 20 cents. A small appropriation (about \$2,000) has been made by the government toward the expenses of the movement. Vienna is the first German University, with the possible exception of Berne, to inaugurate University Extension.

IN May of the present year the Universities of St. Petersburg, Moscow and Kieff replied to an inquiry from the Minister of Education unambiguously favoring the establishment of laboratories of psychology in all of these universities. A committee of eight professors from the University of Kieff have petitioned for about \$3,000 for the establishment of a laboratory of psychology, and a yearly appropriation of \$300.

PROF. E. OTIS KENDALL, since 1855 professor in the University of Pennsylvania, has resigned his position of Flower professorship of astronomy, but remains the nominal head of the department of mathematics and honorary dean and vice-provost.

PRESIDENT HILL, of Rochester University, has consented to postpone until the first of January his resignation from the presidency. His action is due to an address adopted unanimously by members of the faculty, urging him to retain his position.

DR. HERBERT NICHOLS, formerly instructor in psychology in Harvard University, has been appointed lecturer in psychology in Johns Hopkins University.

CARLETON COLLEGE, Northfield, Minn., has received \$8,000 bequeathed by James H. Carleton, among other charitable bequests which now take effect on the death of his sister.

A NEW University, entitled *Université Nouvelle*, with power to confer degrees in all faculties, has been established in Brussels under the control of socialistic leaders. Among the professors are the geographer Prof. Elisée Reclus and the

jurist Prof. Enrico Ferri, both of whom were unable to hold positions in their own countries. The opening address of the Rector Professor Janson urged that property should only be acquired by labor and that the State should be the only heir. Sixty students were matriculated at the opening of the University, the future of which will be followed with interest.

PROF. RUTH has been appointed professor of geodesy in the Technical High School of Prague and Dr. v Rudzki assistant professor of mathematics in the University of Krakau. Dr. Kempf and Dr. Wilsing, astronomers at Potsdam, and Dr. E. Buchner, a chemist of Kiel, have been appointed to professorships. Dr. C. von Twardowski, privatdozent in the University of Vienna, has been elected assistant professor in philosophy in the University of Lemberg.

CORRESPONDENCE AND DISCUSSION.

A LAST WORD ON ERECT VISION.

I SAY 'last word' because I hope it may be the last I shall say on this subject at present, fearing that I have already occupied too much space, and not in the sense of a final solution. In the latter sense the last word is never said on any scientific question, much less on this question which has been discussed for two centuries and will probably be for two centuries more. But I wish, if possible, to state clearly the question as it seems to me, so that I shall not be misunderstood.

I agree with Prof. Minot that erect vision is *acquired by experience*. Yes, but *not by individual experience*. For the individual it is undoubtedly an inherited capacity—an endowment. It is acquired by experience, true; but by experience along the whole line of the evolution of the animal kingdom, and especially of the eye; and more and more fixed in brain structure or mental structure; until finally it is thoroughly inherited as any other capacity. This is, it seems to me, proved by cases of operation for congenital blindness from double cataract in persons sufficiently old to have acquired definite ideas of position in space by means of other senses. I refer now to only one carefully observed case recorded in the *Revue Scientifique*, Vol. 50, p. 571, 1892. An intelligent child,

blind from birth by double congenital cataract, was operated on at the age of six years. After removal of the bandages she saw at once, and without learning by experience, all things in their proper positions. Perception of *direction and position* was immediate, but not so the perception of the *relative distance* of objects. The former is a primary gift of sight, the latter a judgment and must be acquired by experience.

In this controversy we have again repeated the three old views on this subject. 1. The *nativistic theory*: It is a direct endowment of the eye or the brain, and there an end. This is the usual popular view. 2. The *empiristic theory*: It is acquired by individual experience, as we acquire the proper manipulation of the glass slide under the microscope. This is Prof. Minot's view. 3. The *metaphysical theory*: It needs no explanation at all. There is no such thing as up and down for the soul. This last we put aside as not a scientific solution. As to the other two, they are completely reconciled and the question, it seems to me, solved, as so many other vexed questions are solved by evolution. It is acquired—yes, but not by individual experience. It is inherited—yes, but not without experience.

Now, as to the legitimacy of my own explanation. A similar acquisition of ideas of *direction or position* in space by ancestral experience inherited and fixed in structure has taken place in all the senses, but especially in senses of touch and sight. Is it not legitimate to reduce these or their physical concomitants to a common law? Prof. Cattell (SCIENCE for Nov. 15, p. 668) objects that the different sensations are wholly *disparate* and, therefore, they cannot be explained the one in terms of another. This is true of *sensations proper*, such as light, color, sound, contact, etc., but it is not true of *direction and position*. These are not sensations; they are not peculiar to one sense. These are ideas underlying all the senses, gradually grown up in the mind as the result of deliverances of all the senses. They are not disparate for different senses. These ideas of *direction and position* in space are indeed purely *psychical*, true; but ought we not, if possible, to reduce their physical concomitants to law? This is what I have attempted to do.

I do not, of course, hope to settle this question

to the satisfaction of all. I only wish to show that my explanation is not illegitimate as Prof. Cattell thinks, nor unnecessary as Prof. Minot thinks.

In conclusion I confess I do not quite see the relevancy of Prof. Minot's parenthetic remark. I do not see in what way the turning back of the retinal fibres to end in the rods and cones in vertebrates—though not in invertebrates—can affect the question of reference back along the ray line.

JOSEPH LE CONTE.

BERKELEY, CAL., November 29th.

MOUNTAIN CLIMBERS AND THE PERCEPTION OF DISTANCE.

TO THE EDITOR OF SCIENCE: I do not know that the attention of psychologists has been sufficiently called to the experience of mountain climbers as bearing on the problem of the perception of distance. Both Sir Martin Conway in his recent book, 'The Alps From End to End,' and M. Bonvalot in his book, 'Across Thibet,' have some suggestive remarks of the same general tenor on this subject, but I will quote only those of M. Bonvalot, as they seem on the whole the most pertinent. Speaking of the highlands of Thibet, he says: "It is difficult to imagine how hard it is to find one's way among these highlands, where a man loses all sense of perspective, his eye wandering over immense spaces without seeing, at given distances, either trees, houses, human beings, animals, or edifices the height of which is known to him. It is by the incessant and unconscious comparison of such objects as these that he has learned to form an idea of distance. Here in the desert we have in a few weeks lost this sense of distance which we had gained by the experience of our lifetime. All that one sees is so alike; one hill is like another; according to the time of day a frozen pool either sparkles in the sun or disappears, so that one does not know whether it is large or small; a little bird fluttering its wings upon a clod of earth looks like a wild animal which has been lying down and is getting up; a crow flying away with its prey in the morning mist seems to be a gigantic condor carrying off a lamb in its claws, while at sunset this same crow, cleaning itself on the

summit of a rock, looks the size of a yak or a bear."

It is plain from this experience that M. Bonvalot happened upon a new spatial world of size and distance, which he had to learn by a method of local visual signs, just as in infancy he learned the space world of the nursery room. It would be interesting to inquire of such travelers the exact nature of the signs they used in constructing the new space world.

HIRAM M. STANLEY.

MR. SPENCER ON TACTUAL PERCEPTION AND
'NATURAL SELECTION.'

MR. SPENCER concludes his long discussion on 'Natural Selection' by a short note in the October number of the *Contemporary Review* in which he claims that he has received from Prof. Weismann no answer to the crucial question he asked in his original paper (*id.*, Feb., 1893). Mr. Spencer writes:

"But the main question he has every time passed over in silence. To my repeated inquiry—*How are the various degrees of tactual discriminativeness possessed by different parts of the outer surface of the body to be explained by 'natural selection' or by 'pannuzia'?* he has not only given no answer, but he has made no attempt to give an answer. The obvious implication is that no answer can be found."

Now, as I have already attempted (*Mind*, Oct., 1893,) to prove that Mr. Spencer's arguments from tactual perception are futile, and as his reply (*Contemporary Review*, Dec., 1893,) shows that he is not likely to be influenced by such evidence as I am able to adduce, I do not return to the subject in the hope of convincing him. I may, however, be able to show others that the facts of tactual perception have no special bearing on the sufficiency or insufficiency of natural selection.

Mr. Spencer found that the sensation areas (the distance apart at which points on the skin can be distinguished) on the tips of the fingers of two blind boys were $\frac{1}{16}$ inch and of two compositors $\frac{1}{17}$ inch, whereas Weber gave $\frac{1}{12}$ inch as the normal size. Mr. Spencer concludes from this experiment that the structure of the peripheral nerves and their connections are altered by use, and that these modifications of structure are hereditary. The fact that the tip of the

tongue is more sensitive than the tips of the fingers is said to be because the tongue is continually exploring the teeth, although no advantage is gained thereby; the nose is more sensitive than the top of the head because it is more often rubbed by the fingers, etc. Mr. Spencer says that as the sensitiveness of the tip of the tongue is less important to man than sensitiveness of the finger tips it is impossible that the greater sensitiveness of the tongue could have been developed by the survival of useful variations.

Now this argument is such that the only reason for replying to it is that it is advanced by Mr. Spencer, whose contributions to philosophy are on the whole so important, that his utterances on special matters carry weight that they often do not intrinsically possess.

The experiments and theories of Weber have long since been superseded. Many thousands of experiments on tactual discrimination by a score of investigators have been published, and of these Mr. Spencer is ignorant. It is well known that the tactual discrimination of the blind is likely to be greater than that of others, but this could not have been determined from an experiment such as Mr. Spencer made. Tactual discrimination decreases in five minutes' practice far more than the amount given by Mr. Spencer as the greater sensitiveness of the blind; but this does not mean that the anatomical structure of the peripheral nerves has been modified, and that this modification will be hereditary.

The distribution of tactual discrimination on the skin seems to be exactly what would be expected were 'natural selection' a sufficient or an insufficient account of organic evolution. The parts of the body in which sensitiveness is most useful, the finger-ends and the tongue, are in fact the most sensitive.

There are two adequate reasons why the tongue should be more sensitive than the fingers. In the first place the lower mammals use the tongue as an organ of touch, it being far more sensitive than their hoofs or paws; a horse will reject the smallest bit of gravel from its mess of oats. As sensitiveness of the tongue is extremely useful to man for mastication and speech it is natural that the delicacy early de-

veloped should have been maintained.* † In the second place accuracy of skin localization is always a function of the mobility of the part. Where anatomical structure varies within narrow limits the sensation areas are small. As the tongue is far more mobile (the mobility is highly useful) than the finger tips, it could more readily develop and retain tactual sensitiveness.

In all cases where the structure or function of an organ is useful to the individual it may be attributed to the survival of variations or the inherited effects of use, and it does not seem that tactual discrimination helps to decide the all-sufficiency or relative importance of one of these factors.

When Mr. Spencer says that the sensitiveness of the tongue has been developed by involuntary and useless rubbing over the teeth, he seems to betray a complete misapprehension of the facts of psychology. The skin becomes less, not more sensitive by continual rubbing of the clothes, the contact of air, blood and food does not develop the accuracy of local discrimination in the inner organs of the body, etc.

I scarcely know a worse argument than this of Mr. Spencer's: (1.) That the blind are shown to have greater tactual sensitiveness than the seeing. [This would not be proved by Mr. Spencer's experiment but was well known.] (2.) That in these cases the practice of the blind has developed new anatomical structures of the peripheral and central nervous system. [A greater increase in accuracy of local discrimination can be developed with five minutes' practice.] (3.) That the anatomical structure acquired by use is hereditary. [This begs the question at issue.] (4.) That the relative sensitiveness of the skin cannot be accounted for by the survival of useful variations. [It is amply accounted for.] (5.) That useless sensitiveness has been developed by continual stimulation. [This is nonsense.] J. MCKEEN CATTELL.

BIBLIOGRAPHY OF NORTH AMERICAN
PALEONTOLOGY.

ONE of Mr. Van Ingen's criticisms in a late

* It may be remembered that Mr. Spencer thinks that organs will not disappear through 'natural selection' when they become useless.

† The nose is also used as an organ of touch by the lower mammals, and naturally remains more sensitive than the top of the head.

number of SCIENCE, on the recently issued Bibliography of North American Paleontology, 1888-1892, suggest that one of the errors into which he has fallen might also apply to others, particularly authors in paleobotany whose names have been omitted and of which a number are given as not being listed. The paleobotanical papers were omitted intentionally for the reason that they were already receiving attention for publication in the U. S. National Museum when the work on the Bibliography was commenced. This fact should have been perhaps emphasized in the preface. But that there is so large a number of omissions as is claimed cannot be for a moment believed until substantiated by facts. In case the latter are forthcoming it would save much trouble in looking them up. Several, at least, of the 'valuable' additions made by Mr. Van Ingen as appearing during the period, while they do bear an included date on the title pages, were not received until sometime afterward, as library records clearly show.

As to many of the titles not being given in 'full,' as it is claimed by Mr. Van Ingen to be promised in the preface, it need only be stated that if he had turned his naked eye to the Bibliography instead of his microscope, he would have found some 800 other titles not given 'in full,' in place of the half dozen cited as examples of 'wrong copying.' In a listing of the papers all articles and often unimportant adjectives were purposely omitted, for reasons obvious to everyone familiar with bibliographic matter. 'Full' is clearly used in contradistinction to the usage in the secondary references where abbreviation as great as possible is necessary.

The regret expressed by Mr. Van Ingen that the Bibliography was not printed on one side only is no doubt shared by many 'working paleontologists,' even though Uncle Sam could not anticipate the utility of printing so valuable a work in colors to suit each prospective peruser. The special defect mentioned is, however, readily overcome by transmitting 20 cents to the director of the U. S. Geological Survey for a second copy of the work, that the 'pasting on cards' may go on uninterruptedly.

CHARLES R. KEYES.

SCIENTIFIC LITERATURE.

A Handbook of British Lepidoptera. By EDWARD MEYRICK. London, Macmillan. 1895. 6,843 pp., 8°.

Within the compass of a very handy volume, in reasonably large type, Mr. Meyrick has contrived to pack the descriptions of over 2,000 British Lepidoptera, giving at the same time indications of their habitats, distribution, and time of flight, and, where known, a line or two descriptive of the larva, pupa and food plant; analytical keys are also added. It is not only precisely what its title implies, and so must be of distinct service to the young English entomologist, but it is a really new book and not a series of copied or condensed descriptions. It gives the beginner, however, no clue to anything beyond that to which he may go for fuller information, and the descriptions of the early stages are confessedly at second hand and unsatisfactory.

All this, however, hardly interests greatly the American entomologist, and if this were all there would scarcely be need of more than a brief notice in these columns. What gives the book a far wider interest is that the author has endeavored, by means of diagrams under about half of the groups, to express succinctly his views of the phylogeny of that group, and then has arranged the members in a serial order in accordance with their relative distance from what is regarded as the primitive type, the several members of each distinct branch, however, being kept together. Thus the Lepidoptera are divided into nine groups of families, as follows:

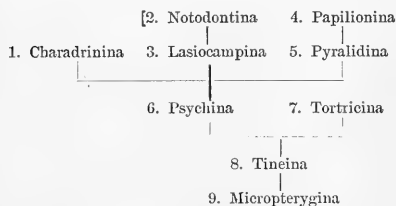

And they are then arranged in the book in the order indicated by the numerals which we have

prefixed. "The order begins," declares the author, "with the most recently developed forms and descends gradually to the earliest or most ancestral, which are the last in the book." This brings the butterflies into the middle of the book, between the Lasiocampina and Pyralidina, a startling innovation, which will not fail to draw instant attention to the impossibility of arranging any large group naturally in a linear series.

It is evident that Mr. Meyrick has made use of the latest researches on the affinities of the different members of the Lepidoptera (which have been exceptionally important of late), and that he has also brought to the task he has undertaken much critical judgment; but it may well be doubted whether the Manual to appear in another thirty-six years (the time that has elapsed since Stainton covered the same ground) will not see as much change from the present work, especially through investigations on the early stages of these insects, as this work shows when compared with Stainton.

It were much to be wished that the author had used a rational nomenclature for the neuration of the imago, and not have employed the back-handed numerical method so much in vogue among Old World lepidopterists, a method absolutely without meaning and a mask of affinities. Many clear illustrations of the neuration accompany the descriptions, and the work is admirably printed and convenient at every point.

S. H. SCUDDER.

Atlas d'ostéologie, comprenant les articulations des os et les insertions musculaires. Par CH. DEBIERRE, Professor d'Anatomie à la Faculté de médecine de Lille. Paris, Félix Alcan. 1896. Pp. viii, 92. 253 gravures.

The superb anatomical atlases of Bougery and Jacob, and of Bonamy and Beau, have deservedly made French artists famous, and have been a mine from which anatomists of all countries have drawn for the illustration of their works. They are, however, so expensive as to be far beyond the reach of the ordinary student.

The present work has a totally different aim, being an attempt to present in a cheap and con-

venient form the principal topographical facts of human osteology. Its author is already favorably known by an excellent treatise on human anatomy, from which about one-half the illustrations of the atlas are taken. These again are many of them copied from older works.

A compilation made on this plan is necessarily somewhat lacking in artistic effect, and has not the unity that would be secured by a set of original drawings made by a single hand, and embodying a well conceived plan of instruction. There is no settled scale of representation, some of the bones being drawn full size, while others are not more than one-eighth of that and quite too small to show detail effectively. No statement of scale is made in any case, so that the learner is left in doubt as to the size of the object represented. Some of the illustrations appear unnecessary, while many important gaps occur.

For instance, the only example of internal bone architecture shown is a well-known figure of the head of the femur, and this, although said to be drawn from a photograph, is incorrect. The difficult sphenoid is very inadequately treated, its development, so important from a morphological point of view, being wholly omitted. In fact, there is no attempt to show the development of any of the cranial bones but the temporal, and that is not wholly satisfactory.

It is, of course, quite conceivable that Prof. Debiere should think proper to omit morphological subjects from an elementary work, but, why, in that case, should he give a scheme of a theoretical vertebra that will be wholly unintelligible to a beginner without adequate explanation, and devote three figures to Albrecht's rather doubtful theory of the constitution of the superior maxillary bone? Surely a figure might have been spared to show the difference between the primordial, or cartilaginous cranium and the secondary, or membranous one.

The merit of the book lies in its cheapness and availability. While by no means reaching the first rank, it will doubtless be useful to those who cannot purchase the expensive treatises of Testut and Poirier, and in convenience will far exceed those admirable works.

FRANK BAKER.

Catalogue of the Marine Mollusks of Japan, with Descriptions of New Species, and Notes on Others Collected by Frederick Stearns. By HENRY A. PILSBRY. Detroit, F. Stearns. 1895. viii+196. Pp., 8°. XI Pl.

This work has grown out of the collections made by Mr. Stearns, personally or by deputy, 1889-92, in Japanese waters, and which were submitted for identification to Mr. H. A. Pilsbry. It consists of three portions: a list of marine mollusks which have been stated to inhabit Japan, from Yezo to Kiushiu, with references to description or figures of most species, and an enumeration of the special localities at which each species has been found by previous naturalists or by Mr. Stearns. This is followed by a catalogue of the Inland Mollusks taken by Mr. Stearns in Japan, and, finally, by a list of mollusks obtained by that gentleman from the Loo Choo Islands. The work is concluded by an index of genera and sub-genera, and explanations of the eleven very excellent plates. Forty species and eight varieties believed to be new are described. The total number of Japanese marine mollusks, excluding those from the Loo Choo Islands, is about 2400, of which 36 are Cephalopods, 17 Pteropods, 1700 Gastropods and 650 Pelecypods. This is a fauna, nearly twice as great as that of the entire east coast of North America, a comparison which gives a vivid idea of the richness in molluscan life exhibited by the Japanese waters. It is probable that the discrepancy is still greater than these figures would indicate, since the dredge has been much more generally used on the American coast, and there are probably many species yet to be discovered even in the shallow waters of Japan.

The literature of Japanese mollusks is a good deal scattered, in spite of the magnificent publications by Lischke, Dunker, Schrenck and von Martens. This is illustrated by the fact that this work enumerates about five hundred more marine mollusks than the latest monograph by Dunker. Students are, therefore, greatly indebted, both to Mr. Stearns for the liberality which made it possible and to the careful work of Mr. Pilsbry, who has brought together the data for the comprehensive catalogue under review. The printing of the text and the execution of the plates are all that could be desired. Beside

mollusks, thirty species of brachiopods are enumerated, the richest recent brachiopod fauna known, and it may be added that Mr. J. E. Ives has given an account of the Echinoderms, Crustacea and Pycnogonida collected by Mr. Stearns, in the Proceedings of the Academy of Natural Sciences, Philadelphia, for 1891.

W. H. DALL.

ACADEMIES AND SOCIETIES.

THE NEW YORK SECTION OF THE AMERICAN CHEMICAL SOCIETY.

THE members of the New York Section of the American Chemical Society dined at Morrello's, on 29th street, on the evening of the 6th inst., and from there adjourned to the College of the City of New York, 23d street and Lexington avenue, for the regular monthly meeting. This meeting was held in the lecture room of Dr. Doremus, to which the Society had been invited by that well-known chemist, and Dr. Webb, the president of the institution.

The meeting was called to order by Prof. P. T. Austen, and after the reading of the minutes of the last meeting, Dr. C. A. Doremus welcomed the Section to its new quarters, and recounted a brief history of the room and the adjoining laboratories, which are now the oldest rooms in the city devoted to chemical research and instruction. Dr. Wolcott Gibbs, now of Newport, and formerly of Harvard College, was one of the earlier instructors and investigators working in this place.

On motion, the thanks of the Section were extended to Dr. Webb and Dr. R. Ogden Doremus for the courtesy and assistance extended in these comfortable and commodious quarters for the Section's work.

The first paper on the program was that of Dr. P. R. Moale, chemist to the New York and Boston Dyewood Company, entitled, 'A Brief History of Naphthalene.' This brief history proved to be an exhaustive statement of the progress of the development of naphthalene from its first separation by Garden in 1820 from the scale of the condensing vessels used in the distillation of coal tar, believing it to be camphor or something similar thereto, through the work of Faraday, begun in 1826, Reichenbach, in 1831, to the later work of Dumas,

Liebig, Wohler, Stas, Mitscherlich and Laurent, De Saussure and others.

Passing from the history of the formation and occurrence of this body, the reader took up the composition of the compound, presenting results of analyses by the several noted authorities.

| | |
|-------------------------|----------------------------|
| Opperman's result | $C^{30}H^8C^2H^2$ |
| Liebig and Wöhler..... | $C^{20}H^8C^3H^3$ |
| Berzelius | $C^{10}H^4$ |
| Laurent..... | $C^{10}H^4$ or C^6H^{16} |
| Faraday..... | $C^{20}H^8$ |
| Dumas..... | $C^{40}H^{16}$ |
| Dumas and Stas..... | $C^{30}H^{16}$ |

The reader then took up the constitution of the compound. Beginning with the investigations of Kolbe and Marignac in this regard he discussed the results obtained by Berthelot, Ballo, Graebe, Liebermann, Arnheim, Wreden, Claus, Baeyer and Perkin, Fittig and Erdmann, Bamberger; and from which it has been shown that the formula established by Graebe is that which must at present be accepted as nearest the truth.

In the discussion which followed, of the theoretical constitution of naphthalene, Mr. H. S. Neiman was called upon, and gave his experience in attempting the synthetic preparation of naphthalene for the purpose of throwing light on its constitution. He stated that the decomposition of certain amido-naphthal-sulpho-acids having a tendency to show that the position of the double bonds in the naphthalene ring are not symmetrical, attempts were made to disprove this by the synthetic production from ortho-xylene-tetra-bromide and ethane. By passing ethane over a heated mixture of granulated pumice stone and ortho-xylene-tetra-bromide, a portion of naphthalene was formed, but circumstances prevented further investigation. This formation would seem to show that the central bond is a double one, and the formula a symmetrical one as far as the bonds are concerned.

The second paper on the programme, that of Dr. T. B. Osborne, of the Agricultural Experiment Station at New Haven, Conn., on 'Vegetable Proteids,' is an exhaustive resumé of the classic work of the author upon these interesting and really little known bodies. He reviewed first the earlier investigations of these compounds, particularly those of Einhof, Berzelius, Dumas and Cahours, Ritthausen, Weyl

and Liebig, setting forth the state of our knowledge of the subject at the time of taking up his own study of it, and showing the tendency of professional opinion to the effect that a very close relation exists between the proteids of seeds and those of the animal system. The results of Dr. Osborne's work show the fallacy, except in a general way, of this opinion, and set forth the reasons why it cannot be accepted.

He takes up the proteids of the seeds in systematic order, beginning with the most soluble, and discusses the pterones, proteoses, albumins, globulins, glutinoids, alkali-soluble proteids, and nucleole-albumin and nuclein. He separates these substances by means of solvents such as alcohol, strong and dilute, salt solutions, weak alkali solutions, and precipitating them from the solutions by various reagents, obtains them in forms in which they may be studied. The results he has secured in this way are of the highest interest and value to the history of this class of bodies.

The third and last paper on the program was that of Dr. J. H. Wainwright, of the United States Laboratory, in this city, on 'The Determination of Solid Fats in Artificial Mixtures of Vegetable and Animal Fats.' His method consists in subjecting the mixture to pressure at the ordinary temperature of the laboratory, about 70° F. Much lower or much higher temperatures he finds detrimental to accuracy, as at 60° considerable of the higher melting point constituents are retained, while at 80° F. and above much of the low melting point constituent is removed. The method was devised particularly for the separation of compound lards containing cotton-seed oil, lard and stearine, with the special object of determining the percentage of oleo-stearine, which, in the presence of lard, could not be satisfactorily done by the ordinary methods where the information was obtained from the iodine number and other constants. Results were obtainable by this method within 1 per cent., but at present, until further investigated, the author allowed 1½ per cent. either way, or a total error limit of 3 per cent. in reporting results.

The General Secretary called attention to the time and place of the next and twelfth general meeting of the Society, which will take place

on the 30th and 31st of this month at Cleveland, Ohio, and at which an unusually interesting and valuable program will be presented.

The next meeting of the New York section will be on the 10th of January.

DURAND WOODMAN,
Secretary.

THE ANTHROPOLOGICAL SOCIETY OF WASHINGTON.

THE regular meeting of the Society was held on Tuesday evening, December 3d.

Dr. Otis T. Mason read a paper on the 'Influence of Iron Upon Native American Arts,' of which the following is an abstract:

Aboriginally the manufacture of iron was unknown upon the American continent. The native races, after receiving it, treated it as stone and worked it cold; they have nowhere become skillful in the use of it.

The term 'native American arts,' in common parlance, is ambiguous, now signifying all that the aboriginal tribes do and all that is collected from them; at another time it is made to mean only that part of their activities which they had in pre-Columbian times; at still another time the term is restricted to what the peoples of the Western Hemisphere themselves originated.

To get at the last two, there must be carefully eliminated everything added and suggested by the intrusion of the Iron Age, and everything must be restored that was crowded out, and supplanted by iron and its productions.

This elimination can be intelligently made only by knowing intimately what each intruding people had to bring, and really did bring. The history of America demands a study of the Eastern Hemisphere, especially the folk element and the folk arts in it. One must just as thoroughly know the stocks from which the intruders came. By studying those who came, what they brought, those to whom they came, the knowledge of the added result will be gained. A fact usually entirely overlooked in this connection is this, that as early as 1505 Ovando solicited that no negro slaves be sent to Hispaniola, because they fled among the Indians, taught them bad customs and never could be captured. In 1517 the slave trade was authorized by Charles V, and during three hundred

years, down to the time when scientific studies of the aborigines began to be made, five or six millions of slaves had been imported, a number equal to the entire native population of both Americas.

In the first half century middle America and South America were Latinized. The Dutch, French and English had monopolized North America in its northern and eastern portions two centuries ago. The Russians for more than a hundred years have contaminated the native arts of the northwest. Nine hundred years ago the Scandinavians invaded Greenland and six hundred years ago they were absorbed or killed by the natives.

The earth, even, does not divide the old from the new. The insidious iron is in shell heaps, in mounds, in cemeteries, in huacas and in ancient works of art.

Since these things are indisputably so, it behooves the true ethnographer, the true archaeologist, the true linguist, the true historian, to enter into a friendly coöperation to reconstruct the native activity.

There are some things in favor of the true science, in spite of fraud, insufficient data and false labeling. There is, no doubt, a home flavor, a harmonious agreement among all the works of a people and the environment. The iron arrow-head is always coupled with a shaft covered with color and cuttings of an older age. The very shape and application of the new will conform to the methods of the old, though that be not the easiest.

In these transitions the old will sometimes excel, sometimes fall far below the new. Wherein the use of iron was adopted native art improved, wherein it was not useful native arts declined. It is not true that all good things are old or that all old things are good.

The modern contaminated native art is not to be despised, but when correctly understood it not only reveals to us the old that was concealed in it, but it suggests to the thoughtful man many of the roads and methods by which accultivation may proceed.

Major J. W. Powell, President of the Society, read a paper on *cognition*.

GEORGE R. STETSON,
Recording Secretary.

GEOLOGICAL CONFERENCE OF HARVARD UNIVERSITY, NOVEMBER 26, 1895.

Some Causes of the Imperfection of the Geologic Record. By N. S. SHALER.

Our treatises on geology have as yet not given quite enough attention to the array of causes which have tended to bring out imperfections in the geological record. The ordinary accidents of erosion, metamorphism, and the deep covering of beds by subsequently deposited strata have been taken into account, but there are a number of considerations which do not as yet appear to have been fully discussed, without essaying anything like a full presentation of these neglected influences certain of them will here be presented.

First it is to be noted that the record which we seek to interpret is to a great extent made either by the mechanical history of strata or by the organic events which are recorded in them. Certain influences tend in general to bring these divisions of the record into marked contrast with each other. When the process of deposition goes on with great rapidity the result is naturally a section of great thickness, but one which is likely to be barren or of limited fossil contents. Such a set of deposits on account of its great depth is likely to withstand erosion in an effective way and may remain for ages as the record of a time that has left no other monuments; on the other hand, the deposits of the period in question which are of an organic character are likely to be relatively thin, and if they be composed of ordinary limestone are very much more exposed to the assaults of decay.

Wherever we have extensive deposits of calcitic limestones the beds are exposed not only to superficial erosion and the like work of cavern streams, but also to a solutional process which with considerable rapidity may remove the materials composing the beds for all the depths to which the surface waters penetrate. In central Kentucky the spring waters are annually removing from the rocks in the dissolved state nearly as much rock matter as is eroded by the superficial streams. The result of this process will be in time to leave the numerous arenaceous layers which are generally unfossiliferous and to remove the limestone beds which contain the most important part of the record. In this way we may perhaps account for the

relative absence of limestones in the rocks of the pre-Cambrian deposits without trying to assume that those sections were formed under substantially azoic conditions.

The more important records of geological successions have been made on the sea floor which is near the shore. At the present time by far the richest field for the development of marine life is in this narrow belt. It is likely that in early times the proportion of deep-sea species was less than at present and that in the paleozoic horizons the deeper sea may have been comparatively lifeless. But this zone of the richest marine life is precisely the part of the sea floor which is most likely to be subjected to destructive actions. We now recognize that the continents are subjected to successive oscillations which bring this littoral district again and again through the mill of the surf in the alternating movements of elevation and subsidence. Thus the portion of the earth's surface which contains the most valuable part of the geological record is the most exposed to the influences which tend towards destruction.

T. A. JAGGAR, JR.,
Recording Secretary.

ALABAMA INDUSTRIAL AND SCIENTIFIC SOCIETY.

At the meeting on November 22d, President Thomas Seddon in the chair, the following papers were read and discussed:

Mobile Point as the Deep Water Harbor of the Gulf of Mexico. By G. D. FITZHUGH, of Birmingham.

Alabama Barite, or Heavy Spar. By HENRY MCCALLEY, assistant State geologist, of Tuscaloosa.

Alabama's Resources for the Manufacture of Portland Cement. By DR. EUGENE A. SMITH, State Geologist, University.

The Value of the Raw Materials in Iron Making. By DR. WILLIAM B. PHILLIPS, of Birmingham.

The Pig Iron Market, Its Extent and How to Improve It. By JAMES BOWRON, of Birmingham.

Mr. T. H. Aldrich gave a short talk on his recent efforts in prospecting for gold in eastern Alabama, in the counties of Cleburne, Randolph and Tallapoosa.

On motion of T. H. Aldrich the following committee was appointed to arrange for the compiling of statistics on the mineral and iron industries in the State for the purpose of circulating the same monthly to the technical journals, commencing in 1896: Mr. Thomas Seddon, Dr. William B. Phillips and the Secretary.

Dr. William B. Phillips gave a short account of the progress in his experiments in concentration of Red Mountain iron ores.

EUGENE A. SMITH,
Secretary.

ACADEMY OF SCIENCE. ST. LOUIS, DECEMBER 2, 1895.

The Academy held its regular meeting at the Academy rooms, with President Green in the chair and twenty-three members and visitors present.

Dr. H. C. Frankenfield presented a communication on 'Hot and cold Waves' and 'The Deficit in Rainfall During the Past Three Years.' He spoke of the hot waves being caused by low areas, appearing in the northwest and moving east and south, thus bringing about warm winds from the south, and disappearing on the development of high areas in the northwest.

One of the accompanying phenomena of hot waves was hot winds coming from the southwest, their cause being somewhat obscure. Dr. Frankenfield stated that as a rule they move in narrow belts, ranging from 100 feet to half a mile in width. No good cause can be assigned for this, save, probably, local topography. One of their characteristic phenomena is a tremulous motion of the atmosphere, similar to that caused by heated air from a furnace. Also sudden abnormal rises in temperature, one instance being cited of a rise of 7 degrees in ten minutes.

The origin of cold waves is likewise very much mooted. As a rule a low area is followed by a high one, bringing a cold wave with it, but this is not invariable, as the cold wave occasionally comes without the low area, and sometimes without the high.

One theory as to where the cold air comes from is that of the descent of this cooler air from the extreme upper regions; the other theory, that it is simply the cold air of the surface, made so by radiation. In general it may be stated

that a high area acts as a carrier to a cold wave. The most severe cold waves are those in which the low area extends in a long and narrow, trough-shaped depression from the northeast to the southwest.

Dr. Frankenfield regarded the question of drought purely as one of distribution. The rainfall might be normal during a year, yet there would be a severe drought at a certain season of the year, simply because the rainfall was unevenly distributed, being excessive in some months and deficient in others.

Its effect upon the corn crop was illustrated in the case of the present year, where there was a general deficiency of rainfall and yet sufficient precipitation in the late spring and early summer to insure the safety of the crop. Commencing in August, there was an abnormal deficiency, but this was too late to affect the crop.

Mr. Allerton S. Cushman gave an informal talk on the present state of our knowledge regarding Helium, showing that it has been definitely proved that Helium is not a simple elementary gas, but in all probability a composition of two or more elementary gases.

A. W. DOUGLAS,
Recording Secretary.

SCIENTIFIC JOURNALS.

THE AMERICAN GEOLOGIST, DECEMBER.

The first article is by Prof. N. H. Winchell, and is devoted to the comparative taxonomy of the rocks of the Lake Superior region. This is the last in a series of ten papers under the heading 'Crucial Points in the Geology of the Lake Superior Region,' the object of which has been to review and criticise the Correlation Papers on 'Cambrian' and on 'Archean and Algonkian,' by Messrs. Walcott and Van Hise respectively. Aside from questions of nomenclature, in which, as noted in these columns before, Prof. Winchell differs from those authors, he emphasizes two fundamental differences between his classification and that proposed in the Correlation Papers. First, he maintains the *absence* of a great erosion interval between the upper sandstones of the Keweenawan and the horizontal sandstones (Upper Cambrian) of this region; and secondly, he separates from the Keweenawan certain

igneous rocks, especially the gabbros, which have usually been included in that formation. The paper is accompanied by a table giving a comparison between the classification adopted by the author and that used by the United States Geological Survey.

Mr. Oscar H. Hershey discusses the history of the river valleys of the Ozark Plateau from Jurassic time to the present day. He recognizes several periods of depression and deposition and of elevation and erosion, and summarizes these periods as follows: 1, Jura-Cretaceous peneplain; 2, Tertiary valleys; 3, Lafayette formation; 4, Quaternary valleys; 5, Columbia formation; 6, the present valleys.

Prof. F. W. Cragin, in a paper of nearly thirty pages, gives a careful account of the Belvidere (Comanche Cretaceous) beds of southern Kansas. The typical section noted is called the Elk-Otter section, and this is described in detail, and the fossils characterizing the different beds are listed. The paper includes a statement of the classification of the Comanche divisions and terranes as adopted by the author.

Under 'Correspondence' Prof. G. Frederick Wright presents the views of Dr. N. O. Holst on the continuity of the Glacial period as expressed in a recent paper by that author entitled 'Has there been more than one Ice age in Sweden?' The usual reviews of current geological literature, list of recent publications, and personal and scientific news are given; under the latter is a statement concerning the operations of the Geological Survey of New York during the year.

NEW BOOKS.

Lehrbuch der Botanik. DR. STRASBURGER, NOLL, SCHENCK and SCHIMPER. Second edition revised. Jena, Gustav Fischer. 1895. Pp. vi + 556. M. 6.50.

Lehrbuch der Entwicklungsgeschichte des Menschen und der Wirbelthiere. OSCAR HERTWIG. Fifth edition revised. Jena, Gustav Fischer. 1895. xvi + 612. M. 11.50.

Geological Survey of New Jersey: Annual Report of the State Geologist for 1894. Trenton, The John L. Murphy Publishing Company, Printers. 1895. Pp. ix + 303.

SCIENCE

NEW SERIES.
VOL. II. No. 52.

FRIDAY, DECEMBER 27, 1895.

SINGLE COPIES, 15 CTS.
ANNUAL SUBSCRIPTION, \$5.00.

GUSTAV E. STECHERT'S Recent Importation of Scientific Books.

APEL, DR. MAX. Kants Erkenntnistheorie u. seine Stellung zur Metaphysik. Eine Einführung in d. Studium von Kants Kritik der reinen Vernunft. 147 Seiten. 8°. Mk. 3⁰⁰.

BAAS, J. HERM. Die geschichtliche Entwicklung des ärztlichen Standes u. der. medicinischen Wissenschaften. Mit 2 Abbildgn. 480 Seiten. gr. 8°. Mk. 11⁰⁰.

BIEDERMANN, W. Electrophysiologie. 2^{te} Abtheilung. Mit 149 Abbildungen. 857 Seiten. gr. 8°. Mk. 9⁰⁰.

BUCHKA, DR. KARL VON. Physikalisch-chemische Tabellen der anorganischen Chemie. 348 Seiten. gr. 8°. Mk. 10⁰⁰.

FUCHS, DR. GOFTHOLD. Anleitung zur Molekular-gewichtsbestimmung nach der 'Beckmannschen' Gefrier- u. Siedepunktmethode. Mit 18 Text Figuren. 14 Seiten. Cloth. M. 1⁰⁰.

GERARD, ERIC. Mesures Electriques. Leçons professées à l' institut electrotechnique 'Montefiore annexé à l' université de Liège, Avec 198 figures dans le texte. 457 pages. Cloth. Francs 12⁰⁰.

GOMPERZ, THEOD. Griechische Denker. Eine Geschichte der antiken Philosophie. 1^{ster} Band. 478 Seiten. gr. 8°. Mk. 10⁰⁰.

GRUNMACH, DR. LEO. Lehrbuch der magnetischen u. electricchen Maassheiten, Messmethoden u. Messapparate. Mit 342 in den Text gedr. Holzschnitten u. vielen Tabellen. 632 Seiten. Mk. 16⁰⁰.

HAMMARSTEN, OLOF. Lehrbuch der physiologischen Chemie. 3^{te} völlig umgearb. Auflage. Mit Spectral tafeL. 647 Seiten. gr. 8°. Mk. 14⁰⁰.

KIPPENBERGER, DR. KARL. Beiträge zur Reinsolung, quantitativen Trennung u. chemischen Charakteristik von Alkaloiden u. glycosidartigen Körpern in forensen Fällen, mit besonderer Rücksicht auf den Nachweis derselben in verwesenden Cadavern. 58 Seiten. 8°. Mk. 1⁰⁰.

KISSLING, P. B. Beiträge zur Kenntniss des Einflusses der chemischen Lichtintensität auf die Vegetation. 28 Seiten. gr. 8°, mit 3 Platten. Mk. 3⁰⁰.

KRATTER, DR. JUL. Der Tod durch Electricität. Eine forensisch-medicin. Studie auf experimenteller Grundlage. Mit 7 Abbildgn. und Tafeln. 159 Seiten. gr. 8°. Mk. 7⁰⁰.

LE BLANC, DR. MAX. Lehrbuch der Electrochemie. Mit 32 Figuren. 226 Seiten. 8°. Mk. 4⁸⁰.

LEVY, S. Anleitung zur Darstellung organisch-chemischer Präparate. 3^{te} neu bearbeitete u. erweiterte Auflage herausg. v. Dr. A. Bistrzycki. Mit 35 in den Text gedr. Holzschnitten. 210 Seiten. 8°. In paper, Mk. 4⁰⁰; in cloth, Mk. 5⁰⁰.

MÜLLER, E. Die vermeintlichen Inductionsstörungen im Fernsprechbetriebe u. deren Beseitigung. 65 Seiten. 8°. Mk. 2⁴⁰.

NERNST, W. U. A. SCHÖNFLIES. Einführung in die mathematische Behandlung der Naturwissenschaften. Kurzgefasstes Lehrbuch der Differential- u. Integralrechnung mit besonderer Berücksichtigung der Chemie. Mit 61 im Text befindl. Figuren. 309 Seiten. gr. 8°. Mk. 8⁰⁰.

OSTWALD, WILH. Die Ueberwindung des wissenschaftlichen Materialismus. Vortrag, gehalten i. d. Versammlung d. Naturforschers u. Aerzte zu Lübeck am 20^{ten} September, 1895. 36 Seiten. 8°. Mk. 1⁰⁰.

PAULSEN, DR. FRDR. Geschichte des gelehrten Unterrichts auf den deutschen Schulen u. Universitäten vom Ausgange des Mittelalters bis zur Gegenwart. 2^{te} umgearb. u. sehr erweiterte Aufl. 1^{ter} Halbband. 320 Seiten. gr. 8°. Mk. 7⁰⁰.

PLÜCKERS, JULIUS. Gesammelte wissenschaftl. Abhandlungen. Im Auftrage d. Kgl. Gesellschaft d. Wissenschaften zu Göttingen, herausgegeben v. A. Schönflies und Pockels. 1^{ter} Band. Mathematische Abhandlungen, herausgegeben von A. Schönflies. Mit einem Bildniss und 73 Figuren. 620 Seiten. gr. 8°. Mk. 20⁰⁰.

PREYER, W. Die Seele des Kindes. Beobachtungen über die geistige Entwicklung des Menschen in den ersten Lebensjahren. 4^{te} Aufl. 462 Seiten. 8°. Mk. 8⁰⁰.

SMITH, DR. AUGUST. Die Alkoholfrage u. ihre Bedeutung für Volkswohl u. Volksgesundheit. Eine social-medicinische Studie für Aerzte u. gebildete Laien. Mit 7 Abbildungen. 127 Seiten. 8°. Mk. 2⁸⁰.

SPRAUL, DR. ALEX. Erläuterungen zur qualitativen Analyse anorganischer Körper in Bezug auf die practischen Hilfsmittel u. den planmässigen Gang derselben. Mit 50 Abbildgn. im Text. 173 Seiten. 8°. 3⁰⁰.

WEHMER, DR. C. Beiträge zur Kenntniss einheimischer Pilze. Experimentelle Untersuchungen auf dem Gebiete der Physiologie, Biologie u. Morphologie pilzlicher Organismen. II. Theil. Mit 3 Tafeln u. 6 Tabellen. 184 Seiten. gr. 8°. Mk. 7⁹⁰.

GUSTAV E. STECHERT,

810 Broadway, New York.

Macmillan & Co.'s New Books.

Korschelt and Heider.—Text-Book of the Embryology of Invertebrates. Translated from the German by EDWARD L. MARK, Ph. D., Hersey Professor of Anatomy in Harvard University, W. McM. WOODWORTH, Ph. D. With Additions by the Authors and Translators. Part I.—Porifera, Cnidaria, Ctenophora, Vermes, Enteropneusta, Echinodermata. With Illustrations. 8vo, cloth, \$4.00 *net*.
. Parts II. and III. in preparation.

Nicholson.—A Treatise on Money and Essays on Monetary Problems. By J. SHIELD NICHOLSON, M. A., D. Sc., Professor of Political Economy in the University of Edinburgh. Third Edition. With a Second Part to "A Treatise on Money." 12mo, cloth, \$2.00 *net*.

Thomson.—Elements of the Mathematical Theory of Electricity and Magnetism. By J. J. THOMSON, M. A., F. R. S., Hon. Sc. D. Dublin, Fellow of Trinity College, Cambridge, etc. 12mo, cloth, \$2.60 *net*.

Külpe.—Outlines of Psychology, Based upon the Results of Experimental Investigation. By OSWALD KÜLPE, Professor of Philosophy in the University of Würzburg. Translated from the German (1893) by EDWARD BRADFORD TITCHENER SAGE, Professor of Psychology in Cornell University. 8vo, cloth, \$2.60 *net*.

Headley.—The Structure and Life of Birds. By F. W. HEADLEY, M. A., F. Z. S. With 78 Illustrations. 12mo, cloth, \$2.00.

Acton.—A Lecture on the Study of History. Delivered at Cambridge, June 11, 1895. By LORD ACTON, LL. D., D. C. L., Regius Professor of Modern History. 12mo, cloth, 75 cents.

Century Science Series. Edited by SIR HENRY E. ROSCOE, D. C. L., F. R. S.

NEW VOLUME.

Lyell.—Charles Lyell and Modern Geology. By PROF. T. G. BONNEY, D. Sc., LL. D. F. R. S., etc. With Portrait. 12mo, cloth, \$1.25.

McCormick.—The Alps from End to End. By SIR WILLIAM MARTIN CONWAY. With 100 Illustrations by A. D. MCCORMICK. Large demy 8vo, cloth, \$7.00.

Meyrick.—A Handbook of British Lepidoptera. By EDWARD MEYRICK, B. A., F. Z. S., F. E. S., Assistant Master of Marlborough College. With Illustrations. 12mo, cloth, \$3.75.

Tait.—Dynamics. By P. G. TAIT, M. A., Sec. R. S. E., Honorary Fellow of St. Peter's College, Cambridge, Professor of Natural Philosophy in the University of Edinburgh. 12mo, cloth, \$2.50 *net*.

Tarr.—Elementary Physical Geography. With 267 Illustrations and 29 Plates and Charts. 12mo, cloth, \$1.40 *net*.

Trevor-Battye.—Ice-Bound on Kolguev. By AUBYN TREVOR-BATTYE, F. L. S., F. Z. S., etc. With numerous Illustrations and Drawings and 3 Maps. Large 8vo, cloth, gilt top, \$7.00.

Menschutkin.—Analytical Chemistry. By N. MENSCHUTKIN, Professor in the University of St. Petersburg. Translated from the Third German Edition, under the supervision of the author, by JAMES LOCKE. 8vo, cloth, \$4.00 *net*.

MACMILLAN & CO., 66 Fifth Avenue, New York.

SCIENCE

EDITORIAL COMMITTEE: S. NEWCOMB, Mathematics; R. S. WOODWARD, Mechanics; E. C. PICKERING, Astronomy; T. C. MENDENHALL, Physics; R. H. THURSTON, Engineering; IRA REMSEN, Chemistry; J. LE CONTE, Geology; W. M. DAVIS, Physiography; O. C. MARSH, Paleontology; W. K. BROOKS, Invertebrate Zoology; C. HART MERRIAM, Vertebrate Zoology; S. H. SCUDDER, Entomology; N. L. BRITTON, Botany; HENRY F. OSBORN, General Biology; H. P. BOWDITCH, Physiology; J. S. BILLINGS, Hygiene; J. MCKEEN CATTELL, Psychology; DANIEL G. BRINTON, J. W. POWELL, Anthropology.

FRIDAY, DECEMBER 27, 1895.

TENDENCIES OF MODERN ELECTRICAL RESEARCH.

CONTENTS:

| | | |
|---|-------------------|-----|
| <i>Tendencies of Electrical Research:</i> | M. I. PUPIN | 861 |
| <i>The Berne Physiological Congress (II.)</i> | | 880 |
| <i>Current Notes on Physiography (XXI.)</i> :— | | |
| <i>The Moors of Northwest Germany; The Islands of East Friesland; Physiographic Notes from Iceland; Sable Island; The Physical Features of Mauritius:</i> | W. M. DAVIS | 885 |
| <i>Current Notes on Anthropology:</i> — | | |
| <i>The Cradle of Mayan Culture; Ancient Mexican Highways:</i> | D. G. BRINTON | 887 |
| <i>Scientific Notes and News:</i> — | | |
| <i>Harvard College Observatory; Swedish Marine Zoological Station; 'Timber'; General</i> | | 888 |
| <i>University and Educational News</i> | | 892 |
| <i>Discussion and Correspondence:</i> — | | |
| <i>An Easy Method of Making Line Drawings:</i> | E. E. SLOSSON | |
| <i>The Measurement of Colors:</i> | C. L. F. | 893 |
| <i>Scientific Literature:</i> — | | |
| <i>On the Structure of Protoplasm:</i> | E. A. ANDREWS. | |
| <i>Wiedersheim's Structure of Man:</i> | HARRISON ALLEN. | |
| <i>Haddon's Evolution in Art; Mercer's Hill Caves of Yucatan:</i> | D. G. BRINTON. | |
| <i>Remsen and Wyatt's Chemical Experiments:</i> | E. H. KEISER | 893 |
| <i>Societies and Academies:</i> — | | |
| <i>Boston Society of Natural History:</i> | SAMUEL HENSHAW. | |
| <i>New York Academy of Sciences:</i> | WILLIAM HALLOCK. | |
| <i>The Torrey Botanical Club:</i> | H. H. RUSBY. | |
| <i>Geological Conference of Harvard University:</i> | T. A. JAGGAR, JR. | 902 |
| <i>New Books</i> | | 904 |

MSS. intended for publication and books etc., intended for review should be sent to the responsible editor, Prof. J. McKeen Cattell, Garrison on Hudson, N. Y.

Subscriptions and advertisements should be sent to SCIENCE, 41 N. Queen St., Lancaster, Pa., or 41 East 49th St., New York.

MODERN electrical research may be divided into two principal groups. Faraday's discoveries in electro-chemistry form the central part of the first group. The characteristic feature of the second group is Faraday's view of electro-magnetic phenomena, the view, namely, that electric and magnetic forces between material bodies act contiguously, that is. from point to point through the intervening medium, the lumeniferous ether. These two groups are the foundation pillars which support the splendid edifice of the modern science of electricity. Faraday laid its foundation and he also raised the most essential parts of its splendid structure. But this structure bears to-day so many marks of the genius of Maxwell, Thomson, Helmholtz and Hertz that in our admiration for the exquisite detail which we owe to these great followers of Faraday we often forget the original design and the designer. Even so eminent a mathematical physicist as Poincaré can write profound mathematical treatises on modern electro-magnetic theory with scarcely a mention of Faraday's name.

A broad view of the tendencies of modern electrical research is obtained by comparing the fundamental concepts concerning electric and magnetic phenomena which pre-

*An address delivered before the New York Academy of Sciences, April 28, 1895.

vail to-day to the fundamental concepts which prevailed during the period preceding Faraday. One of the most striking results which this comparison brings out is the evolutionary development of new mental concepts in the science of electricity, going on hand in hand with the accumulation of new physical facts. Faraday was a rare combination of the discoverer and the philosopher, capable of interpreting his experimental discoveries in terms of broader concepts suggested by these discoveries, enriching thus both our knowledge with new physical facts and also our mode of scientific reasoning concerning these facts with new mental concepts.

The concepts which Faraday first introduced into the Science of Electricity form the characteristic elements of the tendencies of modern electrical research. A discussion of these tendencies means, therefore, a careful analysis of these modern concepts.

The two principal elements in our ideas of physical phenomena are necessarily substance and force, that is the seat of phenomena and the agent to whose activity the phenomena are due. It is evident, therefore, that our ideas of electric and magnetic phenomena are, in a certain sense, the same to-day as they were a hundred years ago: that is, they are ideas of the electric and of the magnetic forces, and of the substances in which these forces display their activity. But although these ideas relate to the same concepts, their form to-day is vastly different from the form which they had a hundred years ago; and obviously so, because our ideas concerning forces and substances in general are much broader now than they were then.

The prototypes of our ideas of forces and substances are of course our mental concepts of mechanical force and of ponderable matter, and the Science of Mechanics is, therefore, the foundation of all exact physical

sciences. The Science of Electricity is in more than one sense an extension of the Science of Mechanics, or rather of Dynamics. To this, the oldest and formally most perfect of all exact physical sciences, the Science of Electricity owes its terminology, its definiteness, and its elevation to the level of an exact science. Necessarily so, for the most satisfactory quantitative measure of any accidental quality of matter, like electrification or magnetization, is the mechanical force which accompanies this quality. Thus the history of the Science of Electricity as an exact Science dates from Cavendish's Coulomb's and Ampère's discoveries of the law of mechanical force between electrified or magnetized substances, and between conductors carrying electric currents. The concept of force is to-day and it always was the inseparable bond of union between these two sciences. But just as the history of Mechanics is simply a record of the evolutionary development of our ideas of mechanical force, similarly the history of the Science of Electricity is the history of the continuous expansion of our views concerning electric and magnetic forces. It is owing to this expansion that an apparent emancipation of the younger science from the older has taken place.

We are becoming more and more familiar with the modern division of the Science of Physics into *Physics of Ether* and *Physics of Ponderable Matter*. A closer examination of this modern division of Physics brings us face to face with one of the most important modern scientific doctrines. This doctrine, broadly considered, states that just as the Science of Mechanics is the foundation of physics of ponderable matter, so the Science of Electricity is on the eve of becoming, if it has not already become, the foundation of Physics of Ether. The existence of this doctrine is the most forcible expression of the tendencies of modern electrical research. Such a division is not only permissible and

convenient, but even indispensable, if it is the result of our conviction that the most essential elements of electric and magnetic phenomena, that is, electric and magnetic forces and the substances which are the seat of activity of these forces, cannot be described completely in terms of the concepts of dynamics of ponderable matter. We acknowledge that such is our conviction as soon as we admit that the electric and magnetic forces are manifestations of the various states of a substance which is not ordinary matter and which, therefore, does not form a part of that past experience of ours which led to the formulation of the fundamental axioms of Dynamics. Modern electrical research believes in the existence of a substance which has the relation just mentioned to the electric and magnetic forces, and it has succeeded in identifying this substance with the lumeniferous ether; it sanctions, therefore, a temporary division of Dynamics into *Dynamics of Ponderable Matter* and *Dynamics of Ether*.

In order to approach this subject more closely, it is necessary now to state briefly how our present ideas of electric and magnetic forces developed gradually out of our ideas of ordinary mechanical forces. This is, in my opinion, the most efficient method of distinguishing between the essential and the non-essential elements of Physics of Ether. Without this distinction there is no reliable way of assigning the proper weight to the various features of the tendencies of modern electrical research.

MODERN DYNAMICS AND THE DOCTRINE OF DIRECT ACTION AT A DISTANCE.

Pressures and tensions are the oldest and most intelligible pictures of our ideas of the concept force. But there was a time when these pictures seemed to give us but one phase of this mental concept. They failed to explain the motion of machines and of projectiles, although it was recognized long

before the Science of Statics had reached its stage of perfection in which we find it nearly three hundred years ago, that in these phenomena force was an essential element. It should also be observed that there was a time when the action of a mechanical force between bodies that had no visible material connection was not suspected. Thus Thales, of Miletus, believed to have detected in the attraction of a piece of amber when electrified by friction the presence of an awakened universal soul. The attraction of a loadstone gave rise to most remarkable superstitions. Even Gilbert, the foremost physician and physicist of the Elizabethan age, suspected in the attractions and repulsions between magnets the manifestations of an occult virtue, and whenever he attempted to explain this virtue he necessarily dragged in his ideas of force as illustrated by pressures and tensions in material bodies. 'Horror vacui' and the tendency of bodies to seek their proper place were for nearly two thousand years the only explanations of the action of gravitating force. The modern concept of force as a concise statement of a law of motion was first introduced into the Science of Mechanics by the genius of Galileo Galilei in the seventeenth century. This new, so-called dynamical concept of force, discovered by Galileo as a result of his experiments on the motion of a freely falling body is really nothing more nor less than a concise statement that a freely falling body increases its vertical velocity uniformly with the time of descent, and that, therefore, we can say: the gravitational force acting upon it is constant. Lagrange speaks as follows of this discovery: "It forms to-day the permanent and the most essential part of the glory of this great man. His discoveries of the satellites of Jupiter, of the phases of Venus, of sunspots, and so forth, required telescopes and patience only; but it was a stroke of extraordinary genius to disen-

tangle a law of nature from the phenomena which men always had before their eyes, but whose explanation had nevertheless always escaped the inquiry of the philosopher."

By this discovery Galileo laid the foundation of the modern science of Dynamics. Newton completed the work so well begun; the result is summed up in the three Axioms or Laws of Motion.

Newton's discovery of the law of universal gravitation furnished a splendid illustration of the dynamical concept of force. Newton also supplemented his physical discoveries by a mathematical discovery of equal magnitude. I mean the discovery of the infinitesimal calculus. It enabled him to express the new idea of force by a mathematical formula of rare simplicity, for nothing could be simpler than the formula which states that the flux or rate of change of momentum equals the moving force. This simplicity gave to the dynamical idea of force a fresh and almost irresistible charm. The Newtonian force considered formally is a mathematical symbol, a rate of variation, or, as the mathematician calls it, a differential coefficient, and this symbol considered physically conveys to our mind nothing more than simply a description of the instantaneous state of motion. It matters little what the mechanism is by means of which the moving body receives the impulses of the force. Newton's Dynamics did not explain the mechanism by means of which material bodies gravitate toward each other, nor did it suggest any immediate need for such an explanation. The hypothesis of direct action at a distance worked just as well as any other hypothesis, and it had the advantage of settling aimless discussions quickly when the Science of Dynamics was too busy with numerous important problems awaiting solution to waste its time on needless speculation; and, besides, there were really none but

purely metaphysical arguments that could be brought in the case of gravitational force against this hypothesis of direct action at a distance.

But, unfortunately, that which at one time was looked upon as a convenient hypothesis threatened to become a fixed scientific creed. Newton's dynamics considered force in its aspect of a law of motion expressible by a simple mathematical symbol and nothing else; but just as the Greek mind saw an active divinity in every physical phenomenon, and Thales ascribed the electrical attraction of amber to the manifestation of a universal soul, and Gilbert perceived the activity of an occult virtue in a magnet, so the so-called Newtonian school ascribed an objectively active existence to the law of gravitation and called it the force of gravitation. Even more than that. To Newton the force of gravitation was something merely descriptive; to the Newtonian school of mathematical physicists it was an attribute of matter that had an objectively active existence in consequence of which matter could act upon matter directly at a distance. "It is true," says Maxwell,* "that at one time those who speculated as to the causes of physical phenomena were in the habit of accounting for each kind of action at a distance by means of a special ethereal fluid, whose function and property it was to produce these actions. They filled all space three and four times over with ethers of different kinds, the properties of which were invented merely to save appearances, so that more rational enquirers were willing rather to accept not only Newton's definite law of attraction at a distance, but even the dogma of Cotes, that action at a distance is one of the primary properties of matter, and that no explanation can be more intelligible than this fact. Hence the undulatory theory of light has met with much opposition directed not against its failure to explain phe-

* Treatise on Elec. and Mag., 2d ed., p. 448.

nomena, but against its assumption of the existence of a medium in which light is propagated." The mathematical formula which describes the law of action at a distance of a force like gravitation, electric and magnetic attractions and repulsions was, in the opinion of most mathematical physicists of the last century, the most essential element of and the ultimate goal in our knowledge of this physical concept. For if the direct action at a distance doctrine be accepted what else remains there to enquire into? How much of this scientific creed received a direct support from Newton personally is difficult to tell. One thing is certain; he gave no support to the beautiful undulatory theory of light originated by his friends, Hooke and Huyghens, and it is interesting to observe here that it was owing to the intellectual rebellion of those very men who supported the undulatory theory of light of Hooke and Huyghens against Newton's corpuscular theory that the belief in direct action at a distance began to lose ground.

UNDULATORY THEORY OF LIGHT AND THE
DOCTRINE OF DIRECT ACTION AT
A DISTANCE.

There is one aspect of the Undulatory Theory of Light which, in my opinion, deserves much more attention than is generally devoted to it. This theory gave expression to a current of thought which ran diametrically opposite to the direct action at a distance doctrine of the Newtonian school. For we should observe here that the development of Newtonian dynamics of rigid bodies was accompanied by a steady though somewhat less rapid progress of the dynamics of compressible and incompressible fluids and of compressible solids, that is the Sciences of Hydrodynamics and of Elasticity. Now, Hydrodynamics and Elasticity consider more particularly the modern extension of our original statical concept of force, that is, force

considered as a pressure, a tension, or as a stress of any kind in a continuous material system in which each part, no matter how small, is capable of a relative displacement with respect to the adjacent parts, each such displacement being accompanied by an elastic reaction having a perfectly definite relation to the displacement. This relation cannot be found by abstract reasoning based on the concepts of Statics or on those contained in the Newtonian axioms, but must be determined by actual experiment. Observe now that Hooke, one of the earliest investigators in this experimental field, was one of the founders of the Undulatory Theory of Light. Hydrodynamics and Elasticity containing as they do an additional experimental element mark an advance in our physical knowledge of force and substance over that contained in the Newtonian axioms. The most important element in this advance is the recognition of the very important physical fact that matter is capable of propagating force between the various parts of a continuous material system with a perfectly definite velocity and in a perfectly definite manner, both the velocity and the form of propagation, *that is, the form of the wave*, depending not only on the distribution of the masses of the system, but also on the elastic property of each elementary mass. Hence, whereas the so-called Newtonian school of physicists, influenced by the many unsuccessful attempts to explain gravitational force by mechanical hypotheses, considered force principally in its formal or mathematical aspect and also in aspect of an objectively active property of matter, capable of acting directly at the distance, there was another school of physicists, with Hooke and Huyghens at its head, who focused their attention upon just the opposite aspect of force, that is, force considered as a state of stress, and hence incapable of being communicated from one

body to another, unless there is a material connection between them. It is this view of force which led to the formulation of the Wave Theory of Light; it is also this view of force which gives us the nearest physical picture of the modern view of electric and magnetic forces. But the view of electric and magnetic forces which prevailed during the last century and during the first part of this century was that which accorded with the scientific credo of the Newtonian school. This is easily accounted for. The successful solution of many most remarkable dynamical problems, like the theory of tides, the figure of the earth, the problem of planetary perturbations, etc., commanded most profound attention. They were just so many signal triumphs of Newtonian dynamics and of the Newtonian school. No one dared to doubt the infallibility of anything that *seemed* to have even the remotest connection with Newton's philosophy. The laws of action of Electric and Magnetic forces, that is, the laws of Cavendish, Coulomb and Ampère, all followed the rule of the inverse square of distance and resembled, therefore, Newton's law of gravitation in a most remarkable manner. It is, therefore, not at all surprising that the doctrine of direct action at a distance, which *seemed* to have done so much good in the theory of gravitation, should have been transferred bodily into Science of Electricity and Magnetism.

But the victory of the Undulatory Theory of Light, revived by Young and Fresnel, over the corpuscular theory lessened considerably the confidence in Newton's unquestioned authority and in the correctness of the doctrines of the so-called Newtonian school. Besides, this Undulatory Theory brought into conspicuous prominence a new form of matter which was independent of that mysterious attribute, the gravitating force that acts directly at a distance; a substance permeating all space, even the

innermost interstices of ponderable matter, and capable of transmitting actions between material bodies with enormous velocity. Add to this the invention of the steam engine and the discovery of the galvanic cell, the operations of which had no apparent immediate connection with any formal laws of Newton's dynamics or with Coulomb's and Ampère's distance laws of electric and magnetic force and the scientific atmosphere at the beginning of this century will appear to us in its true light, that is, full of indications that the arrival of a new physical truth was near, a truth which was not explicitly stated in Newton's dynamics and which to be fully appreciated by the human mind needed a new physical concept there, the concept of *energy*. The age which saw the arrival of the Undulatory Theory of Light and of the Principle of Conservation of Energy was worthy of the honor of being the age in which Faraday lived.

FARADAY'S RESEARCHES.

When Faraday entered the field of electrical research, that which he found there worthy of the name of an exact science were Coulomb's, Cavendish's and Ampère's laws of force of inverse square. The method of analyzing electric and magnetic phenomena which prevailed at that time is well illustrated in Poisson's theory of induced magnetism, "who," and here I quote Maxwell, "by following the path pointed out by Newton and making the forces which act between bodies the principal object of study, founded the mathematical theories of electric and magnetic forces."

The field of Electrical Science, view it as you may, was narrow when Faraday entered it. Besides, the old superstition of direct action at a distance surrounded it on every side like a Chinese wall. There seemed to be no exit, no communication with the outside world of science where Faraday saw wide fields of activity opened

up by the Undulatory Theory of Light and the Principle of Conservation of Energy, with both of which his mind was thoroughly imbued. Electric and magnetic attractions and repulsions between material bodies, induced electrifications and magnetizations and the manner in which these actions between material bodies were modified by a change of the medium separating them—all these phenomena could not fail to reveal to a bold investigator of Nature's hidden laws, like Faraday, that the law of inverse square is by no means the final goal of inquiry concerning electric and magnetic forces. The many failures to pass beyond that goal in the case of gravitational force did not discourage him.

It is far beyond the limits of this brief discussion to give an adequate review of Faraday's epoch making discoveries by means of which the Electrical Science was liberated from its hopeless prison of direct action at a distance theories and started on its new and eventful career. Suffice it to mention briefly the main features only of these discoveries, in order to bring out as forcibly as I can their bearing upon the tendencies of modern electrical research.* Faraday's discoveries are generally known to-day through the technical applications of the fundamental principles which were first established by these discoveries. The dynamo and the motor, the telegraph and the telephone, the induction coil and the modern transformer, all these great inventions, in fact, the whole science of electro-magnetic induction, both pure and applied, are only single illustrations of the wide range which is covered by these discoveries. But it is no more than just to mention here that in the region of electromagnetic

induction a very fair, if not an equal, share of the glory of original discovery belongs to our own countryman, illustrious Joseph Henry.

Faraday can well afford to share these honors with so great a physicist. For it adds to his greatness to have it recorded in the annals of science that the supreme effort in the life work of so great a physicist as Joseph Henry was the first step only in the long series of Faraday's far-reaching discoveries. The phenomena of electro-magnetic induction seem to have absorbed the smallest part of Faraday's attention during the earliest period of his electrical researches, and the question which presents itself to every thoughtful student of Faraday's 'Experimental Researches' is: What called Faraday away so soon from this important and promising field? For who does not feel that the pleasure one gets from reading Faraday's masterly story of his discoveries in electro-magnetic induction, given in the first part of Volume I. of his 'Researches,' ends much too soon? I even venture to suggest that many a one among the students of Faraday, whose taste runs more in the direction of estimating the value of a new discovery by the immediate practical application to which it can be put, has undoubtedly bemoaned the fact that Faraday allowed himself to be drawn away so soon from his researches in electro-magnetic induction to matters so 'abstract as electro-chemistry, electric discharges through gases, specific inductive capacity of dielectrics, magneto-crystalline action, magnetic properties of flames and gases, action of magnetism on light, etc.

But a careful review of Faraday's long series of researches suggests a very intimate connection between the numerous and apparently independent parts of that series. They are all just so many tributary streams which flow into the same main

*The substance of the following summary of Faraday's discoveries and their aim was given by the author in 1894 in the *Electrical World* in a series of articles entitled 'The Faraday-Maxwell-Hertzian epoch.'

current of thought. This current starts from the phenomena of electro-magnetic induction. The tributary streams make it stronger and stronger. It grows wider and wider, and finally as if expanding beyond the limits of our mental vision disappears in the dim regions, which, according to Faraday's surmises, connect the phenomena of light, electricity, and magnetism. The phenomena of electro-magnetic induction inspired the prophetic mind of Faraday with the belief that there must be an invisible mechanism connecting material bodies, and that it is the activity of this mechanism which makes us cognizant of the existence of electric and magnetic forces. He gave expression to this belief by introducing into his mode of thought and of description a new term, the term magnetic curves or lines of magnetic force. At first he gave us only their geometrical definition. "By magnetic curves," he added in a footnote, Volume I., page 32, "I mean the lines of magnetic force, however modified by juxtaposition of poles, which would be depicted by iron filings; of those to which a very small magnetic needle would form a tangent." But the intimate connection between the phenomena of electro-magnetic induction and these curves, or lines of magnetic force, convinced him that these curves had an actual physical existence and that they were not mere geometrical space relations, of which the iron filings give us a convenient material picture. He seemed to be aware that the nature of these new physical existences could not be revealed by a study of phenomena like those of electro-magnetic induction, as long as these phenomena could be observed in bodies of finite dimensions only, and this being the case then he would naturally expect that the road leading to the understanding of the lines of force was by way of the phenomena which can be traced with certainty to the ultimate elements of mat-

ter, to atoms and molecules. This would have been the voice then which called Faraday away from his researches in electro-magnetic induction and bade him rise higher and higher until he reached heights so lofty that only a genius like that of Maxwell could reach him. This is, I venture to suggest, why Faraday's discoveries in electro-magnetic induction led him into researches of what may be called the atomic and molecular region of the science of electricity. From this point of view, the chronological order appears quite natural in which his researches in electro-chemistry, voltaic electricity, specific inductive capacity of dielectrics, disruptive discharges through gases, animal electricity, action of magnets on light, on metals and their compounds, on gases, on crystals, etc., follow each other in rapid succession. The numerous discoveries revealed by these profound researches convinced the great philosopher that his work was in the right direction. With steady aim he forced his difficult journey ahead with giant strides. The most vigorous years of his life were consumed in gathering a vast amount of evidence with which to reveal before our eyes the physical nature of the lines of force, his first inspiration, and banish the old superstition of direct action at a distance. With renewed vigor he returned to this favorite subject toward the closing years of his life. His research 'On the Lines of Magnetic Force; Their Definite Character, and Their Distribution Within a Magnet and Through Space' (Philosophical Transactions, 1852, page 1), given in the twenty-eighth series of his 'Researches,' mark the beginning of the last epoch of his great work. It prepares us to enter into Faraday's innermost thoughts and see that inspiration and those visions which guided his steps for twenty years. The essays which now follow, 'On the Lines of Magnetic Force,' 'On the Physical Character of the Lines of Magnetic

Force,' 'On the Physical Lines of Magnetic Force,' 'Thoughts on Ray Vibrations,' etc., are just like the glow of an approaching sunrise. The fairyland of Faraday's vision begins to appear clearer and clearer in this gently rising light; but, alas! the cloud of old age hides away the beauties of the sunrise itself.

It was reserved for Maxwell to raise the lofty edifice from which we first obtained a clearer view of the wonderland of Faraday's vision.

I cannot do better than sum up this brief statement of the position which, in my opinion, Faraday occupies in the tendencies of modern electrical research, by quoting the following words of Hertz,* the most brilliant of all the pupils of Helmholtz, Maxwell and Faraday: "Faraday heard of the belief that electrification puts something into a body, but he saw that the changes produced were all external and none internal. Faraday was taught that forces jump through space, but he saw that these forces were influenced in the highest degree by the substances which filled the space. Faraday read that electricities certainly existed, but that their forces were a disputed question, and yet he saw that these forces produced tangible effects, although he could not perceive anything of the electrifications themselves. Hence, in his conception, the state of these things became reversed. The electric and the magnetic forces appeared to him as existing, as real, as tangible; electricity and magnetism were things whose existence might be a disputed question. The lines of force, as he called the forces considered as independent entities, stood before his mind's eye as conditions in and of the space, as stresses, as vortices, as fluxes, as something or another

—he could not tell as what—but there they stood, influenced each other, they pushed the bodies and they pulled them, and they continued from point to point, conveying impulses to each other. The objection that nothing but absolute rest was possible in empty space he met with questions: Is space really empty? Does not light itself compel us to assume it as filled? Could not ether which conveys the waves of light become the seat of those changes which we recognize as electric and magnetic forces? Is it not even possible to imagine a relation between these changes and those waves of light? Why could not these waves of light be something like the oscillations of those lines of force?"

"So far did Faraday reach in his conceptions and his surmises. He could not prove them. He busily searched for evidences. The connection between light, electricity and magnetism was the favorite subject of his research. The beautiful connection which he found was not the one for which he looked. Only the highest old age put an end to his efforts."

MAXWELL'S INTERPRETATION OF FARADAY.

Faraday did not form a new school of physicists during his lifetime. His ideas were too original, his view of the electromagnetic phenomena was too different from the generally accepted view of his time, to gain him a large following even among his own countrymen. His generation recognized the value of his discoveries; it failed to appreciate the full meaning of the aims of his speculation. It was reserved for the next generation to grasp this meaning and to explain it in terms of the language of the existing theories. It was by no means an easy task for the next generation to perform. It required a peculiarly constituted mind, a mind combining in itself the qualities of a physical investigator and those of a mathematician. Maxwell was a true

* Vortrag, gehalten bei der 62. Versammlung deutscher Naturforscher und Aerzte zu Heidelberg am 20. September, 1889. Publ. by E. Strauss in Bonn.

representative of this rare combination. When his attention was first drawn to Faraday's work he was fortunately still out of the hearing distance of the seductive voice of the old 'direct-action-at-a-distance-theories.' I say fortunately, for, as Hertz* observed once in his characteristic way, "he who once strayed into the magic circle of these remained a captive there." Maxwell was born in June, 1831. Faraday announced his first discovery in magneto-electric induction in November of the same year. William Thomson, now Lord Kelvin, was then only ten years old, "Before I began the study of electricity," says Maxwell,† "I resolved to read no mathematics on the subject till I had first read through Faraday's 'Experimental Researches on Electricity.' I was aware that there was supposed to be a difference between Faraday's way of conceiving phenomena and that of the mathematicians, so that neither he nor they were satisfied with each other's language. I had also the conviction that this discrepancy did not arise from either party being wrong. I was first convinced of this by Sir William Thomson, to whose advice and assistance, as well as to his published papers, I owe most of what I have learned on the subject."

Maxwell was barely twenty when he first took up the study of Faraday. Sir William Thomson was twenty-four when he first announced, in 1845, in a paper 'On the Elementary Laws of Statical Electricity' (papers on 'Electrostatics and Magnetism,' Article II.), his strong inclination toward the view of Faraday. But Thomson played at that time too prominent a part in the establishment of the Principle of Conservation of Energy and the Mechanical Theory of Heat to allow Faraday's splendid discoveries to occupy his at-

tention completely. Maxwell threw his whole young heart and soul into the study of Faraday's 'Experimental Researches.' It was only a year after he took his degree at Cambridge when his first essay 'On Faraday's Lines of Force'* appeared. This essay and his second essay on the same subject, 'Physical Lines of Force,'† are the forerunners of his great memoir 'On a Dynamical Theory of the Electromagnetic Field.'‡ In his 'Treatise on Electricity and Magnetism'§ the views elaborated in these essays are presented in a somewhat different form and compared to the views of some of the older theories. 'The lines of force,' quoting the words of Hertz, 'as Faraday called the forces considered as independent entities stood before his mind's eye as conditions in and of the space, as stresses, as vortices, as fluxes, as something or another * * .' The first problem, therefore, which confronted Maxwell in his undertaking to express Faraday's views in terms of the terminology of the accepted mathematical theories at that time was evidently this: What is the physical constitution of the medium whose conditions of stress and of motion manifest themselves as electric and magnetic forces, that is, as lines or tubes of electric and of magnetic force? The first and the second essay give strikingly original mechanical pictures illustrating the properties of the medium which will fulfill most of the essential requirements. It would lead us too far to enter into a discussion of the beautiful mechanical models which represent Maxwell's earliest attempts to explain Faraday's view of the activities going on in an electromagnetic field. A popular account of this phase of Maxwell's work will be found

* Cambridge Phil. Transact., Dec. 10, 1855.

† Philosoph. Mag., March, April and May, 1861; Jan., Feb. 1862.

‡ Royal Soc. Transact., Oct., 1864.

§ Clarendon Press, Oxford, 1873.

* 1. c.

† Treatise on Electricity and Magnetism; preface, p. ix.

in Prof. O. Lodge's charming book on 'Modern Views of Electricity.'* Suffice it to state that these mechanical models were temporary structures only, as it were, mere scaffolding, which Maxwell tore down as soon as the building which he started to raise reached its completion. †

In the third essay the description of the physical properties of the medium is not so specific as in the first two. The mechanical models are replaced by broad mechanical hypotheses.

"It appears, therefore," says Maxwell, in the introduction to the famous third essay, "that certain phenomena in electricity and magnetism lead to the same conclusion as those of optics, namely, that there is an ætherial medium pervading all bodies, and modified only in degree by their presence; that the parts of this medium are capable of being set in motion by electric currents and magnets; that this motion is communicated from one part of the medium to another, by forces arising from the connections of those parts; that, under the action of these forces, there is a certain yielding depending on the elasticity of these connections, and that, therefore, energy in two different forms may exist in the medium, the one form being the actual energy of motion of its parts, and the other being the potential energy stored up in the connections, in virtue of their elasticity."

This paragraph contains the keynote of the essay. Its meaning may be illustrated in a simple manner, as follows: Consider a charged Leyden jar. Its energy is potential and stored up in a sort of elastic deformation of the dielectric, principally in that part of the dielectric which separates the metallic plates of the jar. Connect the two plates by a conducting wire; a current is set up and a magnetic field accompanying this current appears. Magnetic force is

due, according to Maxwell's mechanical hypotheses, to some kind of motion in the medium, and, therefore, the appearance of the magnetic field means that the discharging process in the jar consists in a transformation of the potential energy of the charge into kinetic energy of the magnetic field. At the moment when the jar is completely discharged, all the potential energy of the charge, except that part which has been transformed into heat in the conducting wire, appears as kinetic, that is, as magnetic energy of the field. From that moment on, this kinetic energy begins to diminish, because, owing to the peculiar connection of the conducting wire to the moving parts of the medium, the current in it will persist and charge the jar in the opposite sense, which means a retransformation of the magnetic energy of the field into the potential energy of the charged jar, and so on. These cyclic transformations continue until the total initial energy of the charged jar is transformed into heat in the conducting parts of the system. *We have electric oscillations.* These oscillations were observed by Joseph Henry, nearly twenty years before Maxwell wrote his famous third essay; Sir William Thomson discussed their theory in 1853, and Feddersen subjected this theory to crucial experimental tests from 1857 to 1862. But that which, in the estimation of the tendencies of modern electrical research, is the most essential element in our physical view of these oscillatory phenomena is entirely absent from these early investigations. Maxwell, guided by the visions of Faraday, was the first to introduce this element. It is this. If the forces of the electromagnetic field are due, as Maxwell assumed and illustrated by mechanical models, to the reactions of the moving parts of the field, elastically connected to each other, then, since these reactions must necessarily consume time in passing from any part of the field to any

* Published by Macmillan & Co.

† Treatise, Vol. 2, p. 427, 2d. ed.

other, it is evident that in the case of the oscillatory discharge of the Leyden jar, which we have just considered, the oscillatory current in the conducting wire must be accompanied by oscillatory variations of the electric and magnetic force at every point of the field, and that these oscillatory variations are propagated *with a finite velocity and in complete accordance with the laws of propagation of waves through an elastic solid.*

This is the new element which Maxwell introduced into our view of the oscillatory phenomena of electromagnetism, and it is the very heart and soul of the modern electromagnetic theory. Suppose now that these variations are very rapid, and that by a suitable detector of the electric or of the magnetic force we actually detect these waves and measure their length, then the ratio between this length and the period of oscillation will give us the velocity of propagation. Maxwell predicted that this velocity is the same as that of light of the same wave length, but he never told us how to produce these waves nor how to measure their length. In fact, he never mentioned a word about the oscillatory discharges of a Leyden jar, and without a complete understanding of these there *seemed* to be no way of getting at Maxwell's full meaning.

Referring to the theory of these oscillations Mr. O. Heaviside remarks: "It had been given by Sir W. Thompson in 1853, but it is a singular circumstance that this very remarkable and instructive phenomenon should not be so much as mentioned in the whole of Maxwell's treatise, though it is scarcely possible that he was unacquainted with it; if, for no other reason, because it is so *simple* a deduction from his equations. I lay stress on the word *simple*, because it is not to be supposed that Maxwell was fully acquainted with the whole of the consequences of his important scheme." (Electr. Papers, Vol. II., p. 83). The omission is certainly puzzling, but it can hardly be as-

sumed to furnish any evidence, as Mr. Heaviside seems to infer, that Maxwell was not fully acquainted with the whole of the consequences of his theory. For when one sees as clearly as Maxwell certainly did that the waves of light are the same thing as the electric waves, accompanying the oscillations of a Leyden jar discharge, he can well afford to ignore these and pass on without delay to the discussion of the luminous waves considered as electric waves. This was the ultimate aim of what Mr. Heaviside calls Maxwell's 'important scheme.' From a practical, and what one might call a business point of view, it must, of course, be admitted that Maxwell would have promoted much more rapidly his 'important scheme' if he had elucidated it first by the oscillations of a Leyden jar discharge, and this omission is, in a sense, a mark of incompleteness in Maxwell's presentation of Faraday's view of electromagnetic phenomena.

This unfinished part of Maxwell's monumental work remained practically just as Maxwell left it for over twenty years until, in 1887, the genius of Hertz, of Karlsruhe, completed the magnificent structure in a manner quite worthy its original designer. The existence of electric waves accompanying a Leyden jar discharge and their finite velocity of propagation, equal to the velocity of light, was demonstrated by Hertz in a series of brilliant experiments whose parallel one would seek in vain outside of Faraday's 'Experimental Researches.' They revealed to us for the first time the whole view of the electro-magnetic phenomena as they appeared to Faraday and Maxwell; they convinced us that the doctrine of direct action at a distance has no place in these phenomena; and they also inspired us with a hope that our view of the phenomena of gravitation may, perhaps, some day be liberated from the narrow prison walls of this persistent doctrine.

Hertz's contribution to Maxwell's work

did much to make that work what Maxwell intended it to be, that is, an interpretation of Faraday. "If by anything I have written," says Maxwell, "I may assist any student in understanding Faraday's modes of thought and expression, I shall regard it as the accomplishment of one of my principal aims—to communicate to others the same delight which I have found myself in reading Faraday's *Researches*." It is in this sense only that the Hertzian experiments mark a completion of what Maxwell had apparently left undone. They enable us to understand more clearly Faraday's modes of thought and expression, because they supplied the force and the vigor of living experiment where many a physicist saw formerly nothing but the inhospitable realms of what, to many of us, appear as dead symbols only of Maxwell's intricate mathematical analysis; and, above all, they revealed to us the beautiful simplicity of the loftiest among the many lofty conceptions of Maxwell's electro-magnetic theory, that is the 'Electro-magnetic Theory of Light.'

"The connection between light, electricity, and magnetism," says Hertz, "was the favorite subject of his (Faraday's) research." The same statement applies to Maxwell. *The Electro-magnetic Theory of Light is the crowning effort of his immortal work.* The fundamental idea in Maxwell's many-sided view of the phenomena of electricity and magnetism is undoubtedly the idea that the same fundamental laws govern the phenomena of electricity, magnetism and light. To formulate these laws was the ultimate problem of his great work, and when he found its solution it mattered little whether he could or could not devise a logically clear and consecutive course of analysis which would lead others to the same result. Hence the complaint on the part of mathematical physicists,* trained in

* The French school of the mathematical physicists

the school of Euclid, Newton and Ampère, because they miss in Maxwell that perspicuity and logical sequence which we all admire so much in the writings of the mathematical school of the last century. The fundamental laws of Maxwell's electro-magnetic theory, capable, as they are, of explaining not only the phenomena of electricity and magnetism, but also the phenomena of light—these laws are the building which Maxwell proposed to raise on the foundation of Faraday's discoveries and conceptions, the various mechanical hypotheses, on the other hand, concerning the physical properties of the medium which enabled him to carry out his plan in accordance with a predetermined design—these hypotheses are mere scaffolding, which can and must now be taken away if it obstructs our view of the finished building.

It is well to quote here several passages from an essay in which Hertz discussed this matter in his characteristically profound way.* "And now, to be more precise, what is it that we call the Faraday-Maxwell theory?" * * * * "Many a man has thrown himself with zeal into the study of Maxwell's work, and even when he has not stumbled upon unwonted mathematical difficulties has nevertheless been compelled to abandon the hope of forming for himself an altogether consistent conception of Maxwell's ideas. I have fared no better myself. Notwithstanding the greatest admiration for Maxwell's mathematical conceptions, I have not always felt quite certain of having grasped the physical significance of his statements." * * * * "To the question, 'what is Maxwell's theory?' I know of no shorter or more definite answer than the

seems to be especially displeased. One has only to refer to the writings of Poincaré, Bertrand, Duhem, etc., to prove the correctness of this statement.

* Electric Waves, translation by D. E. Jones, p. 20, B. Theoretical.

following: Maxwell's theory is Maxwell's system of equations.* Every theory which leads to the same system of equations, and therefore comprises the same possible phenomena, I would consider as being a form or special case of Maxwell's theory. * * * *"

Boltzman, one of Maxwell's most sincere admirers, introduces his lectures on Maxwell's electro-magnetic theory † with the following verse from Goethe's Faust, which he paraphrased evidently with the intention of describing the desperate state of his mind :

So soll ich denn mit saurem Schweiß
Euch lehren, was ich selbst nicht weiss.

MAXWELL'S ELECTRO-MAGNETIC THEORY OF LIGHT.

These statements, coming, as they do, from so high authorities, do not seem to present a cheerful outlook to those who, like myself, take upon themselves the burden of the ponderous task of popularizing Maxwell's electro-magnetic theory. But the outlook is really not quite as gloomy as it appears at first glance, provided, of course, that one limits himself to the essential parts of Maxwell's story and leaves out the ornamental detail. In other words, the story of what Maxwell actually accomplished can be told in a few and simple words; what he probably attempted to do, but did not accomplish, is a different matter and does not concern us at present. Maxwell's electro-magnetic theory in its simple form and divested of all unnecessary hypotheses can be described briefly as the extension of the meaning of certain well established experimental facts. To state these facts it is well to consider briefly the following well-known experiments:

First: Connect two metal plates, facing each other and forming an electric con-

* What Hertz calls 'Maxwell's system of equations' means the same thing as the expression 'fundamental laws,' mentioned above.

† Vorlesungen über Maxwell's Theorie, etc., publ. by Earth, Leipzig.

denser, to the poles of a galvanic cell. A transient current takes place whose value can be determined experimentally. Experiment tells us that this transient current is proportional to the electromotive force of the cell, so that n equal cells in series will produce n times the transient or integral current. Having charged the condenser we disconnect the cells and then join the plates by a conducting wire and discharge; the integral discharge current is just as large as the charging current, but in *opposite* direction. A charged condenser is, therefore, the seat of an electromotive force acting in opposite sense to the charging electromotive force. The old view maintained that this electromotive force is due to the accumulated electricities in the plates; the Faraday-Maxwell view denies this and maintains that the electromotive force is due to an action of the dielectric separating the plates. According to the old theories the current is a process confined to the conducting parts; in our present case, for instance, it is along the conducting wire and stops at the boundary separating the condenser plates from the dielectric. According to the Faraday-Maxwell view this process continues through the dielectric, and whereas it generates heat in the conducting parts it stores up energy in the dielectric just as a compression stores up energy in the body which is being compressed. The charging cell supplies the action and the dielectric reacts; *the work against this reaction is the energy of the charged condenser, which is, therefore, in the dielectric and not on the surface of the plates, as the old theories supposed.* The charging process or current continues until the electromotive reaction of the dielectric is equal to the electromotive force of the cell, and since the integral current is proportional to the electromotive force of the charging cell it follows that the electromotive reaction of a charged condenser is also proportional to

this integral current. Whatever is true of the condenser as a whole is true of any elementary part of the dielectric. Hence, whenever a current passes through any part of a dielectric it produces there a change of state which we call polarization and a consequent electromotive reaction which is proportional to the total current that has passed through. This total current Maxwell calls total electric displacement, selecting this name evidently for the purpose of bringing out the strong resemblance of the relation just described to the relation between the elastic compression of a material body and the elastic reaction produced thereby. The electric displacement depends also on the nature of the dielectric. Thus, the integral current between the same plates and acted upon by the same cell will be greater if the plates are separated by glass than if the intervening space is a perfect vacuum. The ratio between the two is the specific inductive capacity of the glass. This constant is within wide limits independent of the charging electromotive force and it corresponds to the elastic constant in elasticity. We have, therefore, summing up these relations, the following law of electric displacement or flux:

"Intensity of electromotive reaction in any direction equals the intensity of electric flux in that direction divided by the specific inductive capacity."

Second: A magnetized bar of iron is magnetically polarized just as the dielectric separating the plates of a charged condenser is electrically polarized. The resemblance between the two states is complete. We can speak, therefore, of a magnetic flux or displacement, just as we speak of an electric displacement, and experiment tells us that the first follows the same formal law as the second, viz:

Intensity of magneto-motive reaction in any direction equals the intensity of mag-

netic flux in that direction divided by the magnetic specific inductive capacity or permeability.

It should be observed that no assumption is made that these two physical constants of the medium are the same in every direction. In an allotropic substance they can, and generally will, be different in different directions.

The last law is not rigidly true for conductors of high permeability like iron, nickel, cobalt, bismuth, when the magnetizing force is high. The same limitation exists in the deformation of elastic bodies when the deformation passes beyond the elastic limit. It is not a serious limitation as long as we keep, as we necessarily do in experimental investigations of electric oscillations, within the limits of what may be called the elastic limit of electrification and magnetization.

These two laws describe one of the two essential elements in our modern view of the electric and the magnetic force, that is the view of these forces considered as reactions of the dielectric against the continuance of an abnormal condition produced in consequence of a certain process, called in one case the electric and in the other the magnetic current, having taken place there. These reactions suffice to explain the attractions and repulsions between electrified and magnetized substances, which now appear not as direct actions at a distance, but as a consequence of a definite distribution of reactions in the dielectric separating the bodies under consideration. These laws of electric and magnetic flux occupy in the modern electro-magnetic theory the same position and have the same physical significance as the laws of elasticity in mechanics of a material body. This very important element, we may call it the statical element, our modern view of the electric and magnetic force was first clearly brought out by Maxwell. His failure to illustrate it in a

completely satisfactory manner by a mechanical model is of no material consequence as far as the correctness of the laws of flux and the definiteness of our ideas of this *statical element* of electric and magnetic force is concerned.

We now come to the second essential feature of Maxwell's theory. It deals with what may be called the dynamic element of our modern ideas concerning electric and magnetic force. Oersted discovered that a conductor which is the seat of that progressive process which we call an electric current is accompanied by magnetic forces which are present in every element of the space surrounding the conductor. Ampère formulated the law in accordance with which this force is distributed in space. This law can be stated broadly as follows :

The magneto-motive force around the boundary line of any elementary area is proportional to the electric current, or what is the same thing, to the rate of variation of the electric flux through that area.

This law is one of the fundamental laws of the Faraday-Maxwell theory, but although its form is essentially the same here as it was in the old theories its meaning is very much more comprehensive. In the old theory the magneto-motive force around the boundary of any elementary area through which no conduction current passes is *always* zero. According to the new view the current is not confined to conductors, but extends to the dielectric and its value through any elementary area is equal to the rate of variation of the electric flux or integral current through that area. The law of magneto-motive force just mentioned applies to this current just as well as it does to currents in conductors. Again, in the old theory the magnetic force accompanying an electric current was a direct action at a distance between the various elements of the conductor carrying the conduction

current and a magnetic pole; according to the new theory the magnetic force at any point of the medium is the same in this case as in any other, that is, a magneto-motive reaction in the medium produced by the integral magnetic current, that is, by the magnetic flux or induction, which was set up in the medium while the electric currents in the various parts of the field increased from their zero value to the value which they have at the moment under consideration. It must be observed, however, that since in the law just mentioned the magnetic force figures as a *rate of change of the electric flux*, that this law presents to us the dynamic element of the magnetic force just as Newton's second law of motion presents to us the dynamic element of the mechanical force.

We proceed now to consider a similar aspect of the electric force. Any change in the electric currents brings with it a change in the integral magnetic currents in the various elements of the field, and hence it implies work against the magneto-motive reactions in those elements. Hence, every electro-motive action tending to change the electric currents in any part of the field experiences a reaction to which every element of the field contributes its definite share, just as a change in the motion of any part of a mechanism is accompanied by a reaction to which every other part contributes its definite amount. How does this reaction against a change of the electric current manifest itself? The answer to this momentous question was first given by Faraday when he discovered the magneto-electric induction. This discovery can be described as follows:

Consider a loop of a conducting wire and a magnet, in its vicinity. A change of relative position of the two produces a current in the loop. If the magnet is an electro-magnet, and if we keep the relative position unchanged and change the strength of the

magnet, a current will also be induced in the loop. Again, leaving everything unchanged and changing the shape of the loop only a current will result. In each case the magnetic flux through any surface bounded by the loop is varied, and this variation of the flux produces, according to Faraday's researches, an electro-motive force in the loop. The law connecting the two may be stated as follows :

The electro-motive force around the boundary line of any elementary area is proportional to the magnetic current, or, what is the same thing, to the rate of variation of the magnetic flux through that area.

This law is the fundamental law of the Faraday-Maxwell theory which describes the dynamic element in our view of the electric force. Although the form of this law is essentially the same here as it was in the old theories its meaning is radically different. The old theories believed that unless the boundary line mentioned above consisted of a conductor, no electro-motive force around this boundary would be called into play by the variation of the magnetic flux. In the modern theory this limitation is removed. The current in the loop produced by the variation of the magnetic flux is an evidence that electro-motive reactions are set up in the dielectric surrounding the loop, and this reaction manifests itself as a conduction current when the loop consists of a conducting material. Now an electro-motive reaction in the dielectric is impossible without a previous electric flux, hence every variation of the magnetic flux is accompanied by an electric flux, just as every variation of the electric flux is accompanied by a magnetic flux. The law connecting the variation of the flux of one type to the integral flux of the other type is formally the same in each case.

The question, How does the reaction of the magnetic field against a change of the cur-

rent in any part of it manifest itself? is now easily answered. Evidently since this change of the current is accompanied by a proportional change of the magnetic flux in every part of the field the reaction will be an electro-motive reaction against the electro-motive force tending to produce this change in the current. It is evident also that the electro-motive reaction is proportional to the rate of change of the current; that is to say, the current seems to behave like a moving body in consequence of its inertia. For a moving body opposes an inertia reaction against every force tending to change its velocity, and this inertia reaction is, according to Newton's second axiom, equal to the rate of change of momentum. Hence the striking formal resemblance between the laws of electro-magnetic and magneto-electric induction and the laws of inertia reactions of a connected material system. This is the second essential feature of the modern electro-magnetic theory which Maxwell emphasized by his mechanical models, illustrating the actions going on in the electro-magnetic field.

Summing up the foregoing brief account of the Faraday-Maxwell theory, we can say that, broadly speaking, this theory rests on two laws: *a.* The law of flux. *b.* The law of the variation of the flux. These two laws are formally the same as they were in the old theory, but their meaning is radically different. This difference has been brought about by a substitution of a new view of the electric and of the magnetic force in place of the doctrine of direct action at a distance, the view, namely, that electric and magnetic forces at any point of space are reactions due to the physical state of the dielectric in that point. This state is completely determined by the fluxes in that point and the rates of variation of the fluxes in every part of the field.

The account of the ordinary electro-magnetic phenomena in which the electro-mag-

netic forces are either constant or slowly varying is practically the same in the two theories. The radical difference becomes apparent when these variations are rapid, for it is then only that the currents in the dielectric both the electric and the magnetic show their real power. Hertz was the first to show us how to produce these rapid changes by the disruptive discharge of a Leyden jar.

Maxwell's Electro-magnetic Theory of Light can now be easily stated. Formally it is the same as the Dynamic Theory. For this one starts from the hypothesis that light is a vibratory motion of a substance which is a particular form of matter of very small density and very high rigidity. The fundamental laws of the Dynamic Theory of Light are, therefore, Newton's axioms, particularly the second law of motion, and the law of elastic displacement. Now these two laws bear a perfect formal resemblance to the law of variation of flux and the law of flux respectively; it follows, therefore, that since these two theories start from the same formal laws they will, formally, account equally well for all the simpler phenomena of light.

It would lead us much beyond the already extensive limits of this discussion to dwell even briefly upon the superiority of the electro-magnetic theory over the other theories. I shall mention a few only of the most striking features of this comparison. First, it makes no hypothesis as to the material constitution of ether; the Dynamic Theory does this and fails to reconcile some of its hypotheses, as, for instance, the very high rigidity, with well-known physical facts. The only hypothesis which the electro-magnetic theory makes is that its two fundamental laws apply to ether as well as to any other dielectric. In fact, it defines the fundamental physical properties of ether by these two laws just as Mechanics defines the fundamental phys-

ical properties of matter by Newton's axioms and the law of elastic deformation. It is in this sense that Maxwell's electro-magnetic theory may be called the Dynamics of Ether and treated distinctly from Dynamics of ponderable matter. Second, the hypotheses of the electro-magnetic theory admit of a direct experimental test, those of the Dynamic Theory do not. The Hertzian experiments furnished this test for the electro-magnetic theory and verified its hypotheses. Third, the beautiful picture of the phenomena of dispersion and absorption of light which Helmholtz gives us in his extension of Maxwell's theory forms by reason of its elegant simplicity a striking contrast to the mechanical model of these phenomena which he gave us some twenty years ago. Consider as Helmholtz does the electro-magnetic forces that must be acting between the luminous wave and the definite electric charges which Faraday detected long ago in every valency of the atoms of ponderable matter, and the cloud of uncertainty and of ignorance which for a long time seemed to hang over the region of these most interesting phenomena of light clears away and leaves us rejoicing in the possession of new knowledge, more beautiful than anything that we have ever known before.

"One cannot study this wonderful theory," says Hertz, "referring to Maxwell's Electro-magnetic Theory of Light," with out feeling from time to time that there resides in its mathematical formulæ an independent life and an individual intelligence; that they are wiser than we are, wiser than their discoverer; that they give us more than was formerly put into them."

Boltzmann expresses the same sentiment as Hertz by placing the following verse from Goethe's Faust as the motto of the second volume of his lectures on Maxwell's electro-magnetic theory:

War es ein Gott der diese Zeichen schrieb,
Die mit geheimnissvoll verborg'nem Trieb
Die Kräfte der Natur um mich enthüllen
Und mir das Herz mit stiller Freude füllen.

The summary with which Hertz concluded his famous lecture 'On the Relation between Electricity and Light,' cited above, is the most comprehensive statement of the tendencies of modern electrical research that I know of. I shall, therefore, conclude my discussion with a translation of this summary, hoping that I have succeeded in paving the way to a clear understanding of the following comprehensive language of one of the most profound students of Faraday and Maxwell. Hertz speaks as follows:

"No longer do we see the flow of currents nor the heaping up of electricities in conductors. We only see the waves in air, passing through each other, dissolving and uniting, intensifying and neutralizing each other. Parting from the region of purely electric we arrive step by step to purely optic phenomena. We have crossed the pass; our path grows less steep and approaches a level. The union between light and electricity which the theory surmised, expected, predicted, has been accomplished, comprehensible by the senses, intelligible to our common intelligence. A broad view into both regions greets us at the highest point which we have reached, at the pass itself. The domain of optics is no longer limited to ether waves, the length of which is only a small fraction of a millimeter; it extends to waves which are measured by decimeters, meters, kilometers. But in spite of this extension, this domain appears to us, when viewed from here, as an appendix only to the domain of electricity. This last one gains the most. We see electricity in a thousand places where formerly we found no sure record of its presence. In every flame, in every luminous atom, we see an electric process. But even a non-luminous body, as long as it radiates heat,

is the seat of electric impulses. Thus the domain of electricity is being extended over all nature. It approaches us personally; we learn that in reality we possess an electric organ, the eye. This is the view of the things below, the view of details. The view from this standpoint of the things above, the view of the lofty peaks, the general aims, is not less inviting. There lies directly before us the question concerning direct actions at a distance. Do they exist? Among the many which we believed to possess, one only remains, gravitation. Does this one also deceive us? The law, in accordance with which it acts, makes it suspicious. In another direction, not far away, is the question concerning the nature of electricity. It hides itself, when viewed from here, behind a more specific question concerning the nature of electric and magnetic forces in space, and directly alongside of this, rises the mighty chief problem concerning the nature, the properties of the medium which fills all space, the ether, its structure, its rest or motion, its infinite extension or its finite boundary. Stronger and stronger grows the appearance that this question towers way above all the others, that a knowledge of ether will reveal to us not only the nature of former imponderables, but also of old matter itself and its innermost properties, gravity and inertia. The quintessence of primeval physical doctrines is preserved in the words that 'all that is is made of water, of fire.' Physics of to-day approaches the question whether all that is is made of ether? These things are the ultimate aims of our Science, of Physics. They are, to continue our simile, the last ice-capped peaks of its highlands. Will it ever be granted to us to place our foot upon one of these peaks? Will that happen late? Can it be soon? We do not know it. But we have gained for further efforts a foothold which is a step higher than those which were used before; the

path is not cut off by a steep mountain side; the ascent, at any rate the nearest visible part of it, presents a moderate incline only, and among the rocks there are narrow paths which lead on high; there are many zealous and skilled investigators; how can we but look hopefully ahead to the successes of future efforts?"

M. I. PUPIN.

COLUMBIA COLLEGE, NEW YORK.

THE BERNE PHYSIOLOGICAL CONGRESS
(II).*

THURSDAY, September 12. Morning demonstrations and papers (Chairmen, Profs. Dastre and Einthoven).

Prof. S. Arloing (Lyons) described experiments showing that the persistence of electric excitability of the peripheral ends of divided nerves was of long duration, although varying with the animal and nerve experimented on. The excitability of the spinal accessory and facial nerves lasted in dogs four to five days, in asses eight to ten days. In one case the peripheral end of a cat's sciatic was excitable after thirty-one days. The different kinds of nerve fibres in one nerve trunk have different rates of degeneration and their existence can be thus demonstrated; for instance, the vagus of some animals seven or eight days after section has lost its inhibitory action on the heart, and now produces acceleration on stimulation. In the case of an ass, stimulation of the peripheral end of the vagus produced standstill of the heart accompanied by a rise in blood pressure, which Prof. Arloing considered to be due to tetanus of the cardiac muscle. The graphic record of this experiment was shown.

Discussion by Prof. Schiff.

Dr. M. Arthus (Paris) discussed the action of lime salts in promoting the coagu-

*Continued from Vol. II., No. 50, p. 781. (December 13, 1895.)

lation of the blood. He did not agree with the late Prof. Al. Schmidt that the action of the oxalates in preventing clotting was a specific one, independent of the precipitation of lime salts, as the same action was possessed by citrates and fluorides.

Discussion by Prof. Kühne.

Prof. J. v. Kries (Freiburg) discussed the color-blindness, except for red, of eyes which have been long unexposed to light. He did not agree with Hering that this was due to the activity of the white-black substance alone, for he found the periphery of the retina one to two hundred times superior to the center, and held that the retinal rods by virtue of their visual purple possess the power of adaptation to darkness, while the cones distinguish colors.

Discussions by Profs. Grützner, Hensen, Pfleger (Berne) and Kühne.

Prof. A. Gamgee (Lausanne) described his investigation of the absorption bands in the outer violet and ultra-violet produced by haemoglobin and its derivatives, photographs of which were shown. The absorption bands of Turacin, the pigment containing copper obtained from the feathers of certain birds, were also described. Its ultra-violet absorption band is identical with that of reduced haemoglobin.

Discussion by Prof. Tschirch.

Prof. S. Epstein (Berne) gave an experimental demonstration of the increase in visual acuity caused by auditory impressions. He did not agree with the localization of the nervous process in the cerebral cortex, but held it to take place in the corpora quadrigemina, in which the auditory stimuli are reflected on to the optic nerves, these functioning as efferent as well as afferent nerves. In favor of this view he described an experiment in which faradisation of the cochlear nerve produced movements of the eyes and increased sensibility of the conjunctiva. Prof. Epstein also showed an improved perimeter to be used

in the dark, which rendered simulation extremely difficult.

Prof. Burdon Sanderson (Oxford) showed projections of photographic records of the movements of the capillary electrometer caused by muscle currents. These justified the proposition that there are two kinds of electrical response of a muscle to indirect stimulation, that accompanying the wave of excitation and in addition to this a diminution of the E. M. F. of the previously existing muscle current. This latter is evoked by the constant current, by stimuli of great frequency, by chemical stimulation, and in the strychnine spasm.

Dr. A. Waller (London) projected photographs of the excursions of a Thomson's galvanometer produced by the action current of nerve stimulated for one eighth of a minute every minute and subjected to the action of equimolecular solutions of Na Cl, Na Br, and Na I, of ether and chloroform, and of various alkaloids.

Discussion by Dr. Boruttau and Prof. Fano.

Dr. P. DuBois (Berne) showed an electro-dynamometer for physiological and therapeutical purposes.

Dr. A. Beck (Lemberg) and Prof. Cybulski (Cracow) demonstrated the electrical effects accompanying cerebral activity in the monkey.

Prof. N. Wedensky (St Petersburg) demonstrated the effects of simultaneous stimulation in different rhythms of two points of a nerve, the action currents of which were led through a telephone. Variations of the tone heard were produced by interference between the two stimulations.

Afternoon demonstrations and papers (Chairmen, Profs. Vitzou and Fredericq).

Dr. F. Laulanié (Toulouse) described his respiration experiments in a closed chamber, and discussed the results obtained.

Discussions by Prof. Zuntz.

Prof. W. Rutherford (Edinburgh) projected micro-photographs of preparations of crayfish muscle, the structure of which he has investigated in the contracted and in the relaxed condition. He believes in the fibrillary structure of muscle. Three stages of the process of contraction can be made out, the first two of which are due to the absorption of water by Bowman's elements, which in the third stage actually shorten.

Prof. de Burgh Birch (Leeds) described with the aid of lantern projections the graphic methods used in his laboratory by students, which combine convenience with economy.

Prof. I. Rosenthal (Erlangen) showed his method for the estimation of carbonic acid in air for hygienic purposes. The final titration is done with the aid of phenolphthalein.

Discussion by Profs. Zuntz and Grützner.

Dr. M. Cremer (Munich) described his experiments on the formation of starch in potato sprouts from various sugars. Experiments made hitherto have shown a parallelism between the fermentibility and power to form glycogen of the simple sugars. Dr. Cremer found that the fermentible sugars, Dextrose, Levulose and *d.* Lactose form starch in potato sprouts kept in the dark and free from or with but little starch. A positive result was also obtained once with *d.* Mannose. On the other hand, the unfermentible sugars, Rhamnose, Arabinose, Sorbose and Glucoheptose, gave negative results, but Xylose a positive one. Microscopical preparations were shown.

Dr. E. Gley (Paris) demonstrated experimentally that the intravenous injection of 'peptone' into a dog, the great lymphatic vessels of the liver of which had been tied, does not hinder the coagulation of the blood as usual. He concluded that under the influence of peptone the liver gives rise to some substance preventing coagulation.

Discussion by Dr. Arthus and Profs. Fano and Kühne.

Dr. A. Jaquet (Basle) discussed the influence of tepid baths on nutrition. In fever the number of red corpuscles in the blood is often considerably diminished. After a bath of about the temperature 22° R, the red corpuscles usually increase in number to the extent of from 100 up to 900,000 per cubic millimeter. A similar but slighter effect is seen in individuals not suffering from fever. Antipyrin does not act upon the blood. The artificial heating of a rabbit to 40° and above decreases the number of red corpuscles in the veins of the ears, but increases their number in the liver. Cooling baths would appear, therefore, to improve the tone of the circulation, and thereby better nutrition. The antipyretic action of baths is of secondary importance.

Discussion by Prof. Richet.

Dr. De Rey-Pailhade (Toulouse) demonstrated the formation of sulphuretted hydrogen in liquids containing sulphur by a yeast infusion. He considers a substance to be present in the latter, which he calls 'Philothion,' and which can produce oxidations and syntheses by the formation and interaction of nascent hydrogen and oxygen.

Dr. J. V. Uexküll (Heidelberg) showed a small apparatus for the mechanical stimulation of nerve.

Dr. L. Asher (Berne) showed a rat holder, and myographic records taken with its help.

Dr. F. Schenck (Wurzburg) discussed the interpretation of the observation of Dogiel with the dog, rabbit and cat that stimulation of the cervical sympathetic causes, in addition to dilation of the pupil in the same side as the stimulated nerve, contraction of the pupil of the opposite side. Dr. Schenck's experiments with the dog had shown that, if light was prevented from entering the eye of the stimulated

side, the contraction of the pupil of the other eye did not occur, and must have been, therefore, in Dogiel's experiments a consensual reflex, due to the increased amount of the light admitted by the dilated pupil. This explanation could not apply to the rabbit, as in this animal the consensual pupillar reflex does not occur, but, correspondingly, Dr. Schenck could not here confirm Dogiel's original observation. He explained Dogiel's result that stimulation of the central end of one vagus produced contraction of the pupil of the same side and dilation of the pupil of the opposite side, by a previous section performed for other purposes of the cervical sympathetic of the side stimulated.

Friday, September 13. Morning demonstrations and papers (Chairmen Prof. Rosenthal and Mr. Langley).

Dr. J. B. Leathes (London) discussed the osmotic changes between the blood and tissues. He described the effects of strong solutions of cane sugar and dextrose and of hypo-, iso-, and hypertonic solutions of Na Cl on the passage of fluid through the walls of the blood vessels. Dr. Leathes had found the osmotic pressure of the lymph in the thoracic duct to be 1-2 % higher than that of the blood.

Prof. N. Wedensky (St. Petersburg) showed the following experiments: Stimulation of the frog's sciatic nerve with very strong and rapidly repeated shocks soon produced relaxation of its muscle, which, however, became again tetanically contracted when the strength of stimulation was reduced. Reduction of the frequency produced the same result. There is, accordingly, for every strength of stimulation an optimum frequency, and *vice versa*. When the muscle during strong stimulation of its nerve has become relaxed, direct stimulation of it with moderately strong shocks produces contraction only when the stimulation of the nerve is interrupted.

This is to be interpreted as due to the motor nerve endings under pessimum stimulation acting inhibitorily on the muscle, fatigue being excluded.

Dr. F. Lüscher (Berne) described his experiments on the laryngeal nerves in connection with movements of the œsophagus. Stimulation of the recurrent laryngeal was first found to cause a complete act of swallowing. Three fine branches it gives off to the œsophagus were found by localized stimulation to innervate three overlapping segments of it, local contractions of these being produced. Stimulation of the central end of the divided recurrent, its fellow of the opposite side being intact, gives rise to a feeble act of swallowing.

Prof. H. P. Bowditch (Boston) demonstrated a simple model illustrating the mechanism of the ankle joint, Weber's doctrine regarding which was erroneous. The relations between the power and the weight, both when the former (represented by a spring balance) acts from a fixed point external to the system to be moved, and when (as is the case actually in the body) it acts from a point forming part of that system, can be readily shown.

Discussion by Prof Grützner.

Prof. Hensen (Kiel) demonstrated that a stream of air set in vibration by passing a reed cannot sound an organ pipe or resonator like a steady stream. If the stream is strong the resonator or organ pipe alone sounds; if it be weak the reed alone.

Discussion by Prof. Grützner.

Dr. A. White (London) demonstrated his method for artificial circulation through the frog's heart.

Afternoon demonstrations and papers (Chairmen, Profs. Fredericq and Herzen).

Dr. O. Lanz (Berne) showed various animals, some of which had had their thyroid glands removed ('athyretic'), while the others were having thyroid glands administered to them ('hyperthyretic'). Thy-

roidectomy diminished the egg-laying power of hens, while thyroid feeding increased it. If rodents (which have hitherto been held to be immune to the effects of thyroidec-tomy) are operated on when young, cachexia sets in. Hyperthyretic animals bear apparently normal young, but these soon show disturbances of growth and function; a kitten taken from its mother and fed on cow's milk, however, henceforward developed normally. A thyroidectomised dog had been kept alive six months by feeding with glands and injections of their extract, cessation of which brought on the characteristic cachexial symptoms. Tolerance of the loss of the gland is not established.

Discussion by Dr. Hanau, Profs. Grützner and Herzen.

Prof. E. Drechsel (Berne) gave an account of his investigations into the chemistry of the hornlike skeletal substance of *Gorgonia Cavolinii*, a soft coral. This is insoluble in ordinary solvents, but soluble in strong hydrochloric acid. The dried material contains nearly 8% of iodine, and about 2% chlorine, while the whole ash is only about 7%, the iodine being therefore at any rate partly in combination with an organic substance. From the solution of the skeletal substance in baryta water, an organic iodine compound was isolated, provisionally called iodogorgonic acid, which is probably moniodoamidobutyric acid. This is the first organic iodine compound which has been obtained from an animal. It is derived in all probability from the destruction of a proteid substance containing iodine.

Prof. C. S. Sherrington (Liverpool) demonstrated an experiment previously described by him. After division of the 3d and 4th cranial nerves of a monkey the eye is deviated outwards by the uncompensated action of the rectus externus. Stimulation of the cerebral cortex at a point above the 4th frontal convolution

now produces a rotation of the eye inwards due, according to Prof. Sherrington, to an inhibition of the activity of the nucleus of the 6th nerve. Stimulation of the occipital lobe was without effect.

Dr. A. Waller (London) showed photographic records of the retinal currents produced by stimulations by light.

Discussion by Prof. Kühne.

Dr. Axenfeld (Perugia) showed an experiment on binocular color contrast. If, by means of a colored glass before one eye, one of the two crossed transparent double images of an opaque object is made to appear colored, the other image appears of the complementary color.

Dr. C. Phisalix (Paris) had found that the blood of the Salamander not only has the power to give immunity against the poison of this animal, but renders frogs and guinea pigs, into which it is injected, able, to withstand much larger doses of curare than they otherwise can.

Dr. Z. Treves (Turin) communicated experiments, the graphic records of which he showed, demonstrating that different impulses inhibitory of inspiration as well as expiration, pass along the vagi nerves. Their division, after the prevention of all active expiration by section of the cord, can produce more or less marked inspiratory tetanus, which is cut short by weak faradisation of the central ends.

Discussion by Dr. Boruttau and Prof. Herzen.

Prof. A. Mosso (Turin) gave the results of his experiments on the influence of rarefied air on man made on the summit of Monte Rosa (4,600 meters above sea-level). In absolute rest and especially during sleep the respiratory gaseous interchange is lessened, and even standstill of respiration may occur. This must be due to the lessening of the amount of carbonic acid in the blood, as must also be the accompanying quickening of rate of heartbeat. To this

condition of lessened carbonic acid in the blood Prof. Mosso gave the name of Akapnia. He described also experiments made on apes in rarefied oxygen, the pressure of which was, however, greater than the partial pressure of oxygen in air. In spite of this the apes showed symptoms analogous to those of mountain sickness. These are supposed to be due both to Akapnia and the direct influence of lessened atmospheric pressure on the nervous system.

Discussion by Prof. Zuntz.

Prof. N. Zuntz (Berlin) gave the results of experiments made by Dr. Schumburg and himself, as well as those made by Dr. Loewy on the functions of respiration and circulation in rarefied air. He laid stress on individual differences of effects observed, and pointed out that moderate regular movement may put an end to dangerous symptoms, while, as is well known, great muscular exertion favors the onset of mountain sickness.

At a business meeting on the morning of September 13 it was decided to hold the next meeting of the Congress at Cambridge, in the first week of September, 1898, with Prof. Michael Foster as President. Profs. Sherrington (Liverpool), E. Fredericq (Liège) and Grützner (Tübingen) were elected General Secretaries.

The admission of members to future congresses, the bibliography of physiological literature, the universal use of the metric system by physiologists were discussed, and other questions were relegated to a committee.

During the Congress week there was an interesting exhibition of physiological apparatus and preparations by Profs. Einthoven, Kahlbaum, Kronecker, Mosso, Tschirch and Dr. Cowl; and by the following mechanicians: Albrecht (Tübingen); Castagna (Vienna); Diederichs (Göttingen); Geissler (Bonn); Hennig (Erlangen); Petzold (Leipzig); Pfister (Berne); Runne

(Heidelberg); Schenk (Berne); Siedentopf (Wurzburg); Streit (Berne); Westien (Rostock); Zimmerman (Leipzig).

CURRENT NOTES ON PHYSIOGRAPHY (XXI).

THE MOORS OF NORTHWEST GERMANY.

AT the eleventh session of the German Geographical Congress, held at Bremen in Easter week, last spring, Dr. Tacke gave an account of the moors of northwest Germany, their utilization and their economic importance. He described two classes: the low marshy moors, of grassy growth, and the upland moors, of peaty and heathery growth; the first rich and the second poor in calcareous and nitrogenous matter. When sufficiently drained, spread over with sand, and enriched with artificial potash- and phosphate-bearing fertilizers, the low-lying marshy moors well repay cultivation. In the last thirty years extensive areas of waste land have thus been brought into productivity. The more extensive upland moors are less easily redeemed. An old but ill-advised method consists in burning off the peaty surface at the end of a dry season, producing wide-spread smoky skies. An improved method, introduced from Holland, requires the stripping of the peat, which may be sold for fuel, and the mixture of the bottom soil with the underlying sand. Then after sufficient fertilizing, the surface becomes fruitful. Extensive undertakings for colonizing the moors have been successfully carried out in recent years. (*Geogr. Blätter*, Bremen, xviii, 1895, 198-202.)

THE ISLANDS OF EAST FRIESLAND.

THE islands of East Friesland, lying along the low German coast between the estuaries of the Ems and the Weser, are described by Buchenau (*Geogr. Blätter*, Bremen, xviii, 1895, 202-204) as the last fragments of a formerly continuous coastal margin, built of sand drifted by waves and

winds. Dunes cover much of the surface. Behind the coastal barrier, at first grassy moors, then fresh-water reed-marshes and finally salt-water fens were formed on the slowly sinking mainland, the rate of depression being estimated as certainly less than the figure usually quoted, or three-fourths of a foot per hundred years; but in the eleventh century a more rapid sinking probably took place, as great losses of land followed that date. When first formed, the fens behind the sandy coastal barrier must have had but a small run of tide; it is presumed that the English Channel had not then been worn through, and that, the tides entered the North Sea only around Scotland. After the southern Channel was at last opened—about 1000 B. C., as estimated by some geologists—the tides gained greatly in strength; the coastal barrier was overflowed and repeatedly broken through; the fenland, flooded at high tide, bare at low, was gradually washed away. From the time when the Channel was opened, the people waged an unceasing battle with the sea, and as continually suffered defeat; until at last, driven by necessity, they planned a systematic defense against storm and wave, thus rescuing about half of what had before been lost. The vegetation of the islands is well adjusted to its exposed situation. The grass on the open meadows is kept very short by the action of the winds. Bushes are found only in the valleys between the dunes. There are no trees, except when planted near sheltering houses or dunes; any branch which rises above its shelter is soon killed by the storm winds.

PHYSIOGRAPHIC NOTES FROM ICELAND.

JOHNSTON LAVIS, well known from his studies on Vesuvius, went to Iceland in 1890, and contributes an entertaining account of his expedition to the *Scottish Geographical Journal* for September of this year. Interesting topographic features are

the *gjas*, or rifts in the great lava beds, one to three meters wide and of unknown depth, fairly straight over large areas and explained by the traveller as the result of laccolithic accumulations beneath, by which the surface flows are somewhat raised, arched and cracked. The more fertile districts are covered with alluvial detritus brought down by streams from the various Jökulls; but in some cases the wash of gravel and boulders carried by floods from snow melted rapidly by volcanic heat has been so tumultuous as to devastate the surface over which it is spread. The rivers here subdivide into numerous distributaries, across which the traveller has to wade repeatedly. One of the greatest of these stony deserts is the Myrdals-sandr, caused by the eruption of the Kötlogja; the tremendous force of the inundation is shown by the large boulders which have been transported dozens of kilometers from the foot of the highlands down a slope of, for the most part, very small inclination. The Skapter eruption of 1783, "the greatest outflow of lava known to have occurred in historic times," filled the valley of the Eldvatn and thereby displaced a river which now flows on the lava surface; but so nearly level is this surface that the river is subdivided into many channels—sixteen, where the author traversed it—no one channel having yet grown to be the master of the whole. Thingvalla Lake appears to have had a curious origin; a prehistoric lava flood filled a valley, rising to a considerable depth above some barrier, and freezing a surface layer 32 metres thick; then a vent was opened by which the still molten under lava was drained away, and the surface layer settled down in a basin-like depression, some 8 km. wide by 35 km. long, in the bottom of which the lake now stands among the disjointed fragments of the lava crust. Wind action is very noticeable; much of the older rock surface about Cape

Reykjanes is rounded and polished by the sand blast; sand dunes are numerous on this peninsula, where 'the most dreadful dust storms' occur. Much of the pasture soil is wind-blown, collected at first among lichens and gradually coming to support a growth of turf; where the grass happens to be worn away, the wind blows away the soil; thus a farm may be made or marred in a few years. The careful farmer keeps his turf in good repair.

SABLE ISLAND.

THIS lonesome and dangerous island off the coast of Nova Scotia is recently described by G. Patterson (Trans. Roy. Soc. Canada, xii, 1894, 2°, 3-48). A bank that measures about 200 by 90 miles culminates in the island, now twenty miles long and one mile wide. It consists of two parallel ridges of loose gray sand, stretching east and west, and somewhat convex to the south. Between the ridges lies a long narrow 'lake' that is sometimes connected with the sea by inlets on the south, but these are often closed by storms, and then there are no harbors even for small vessels, and landing is generally difficult. Shoals extend far beyond the ends of the island, east and west, producing a terrible line of breakers with a total length of fifty miles. Strong, conflicting and irregular currents run about the island; floating wrecks sometimes makes a circuit around it. Fogs and storms are frequent; 190 wrecks have been recorded since 1801. The island is rapidly wasting under the attack of the waves, having been 40 miles long by two and a-half wide in 1700. About 1814 the rate of wear was nearly a mile a year. In 1881-82 much ground was lost at the western point during violent storms. In one severe gale, a strip seventy feet wide and a quarter mile long was removed; in another, a strip of the same length and forty-eight feet wide; at one time thirty feet of the land margin

sank down in a few hours. A lighthouse built in 1873 at a cost of \$40,000 was undermined and fell in 1882; it was rebuilt a mile inland, but in 1888 was removed two miles further east. The winds cause a continual change in the form of the sand dunes. Landmarks are thus blown away; hollows and ponds replace hills, and breaches in the sod near the few houses are carefully repaired to prevent the thin soil from being blown away. Wild horses of a small and hardy breed roam over the island in separate herds, each led by an old male. They numbered about 300 in 1828; 400 in 1864; 150 to 250 now. Their numbers have sometimes decreased by starvation caused by the burial of pasturage under the drifting sand; and they have not infrequently been eaten by the inhabitants. The unbalanced condition of the smaller imported fauna is curiously illustrated. English rabbits were introduced at one time and soon overran the island; but they were exterminated by rats that came ashore from some vessel. The government then sent cats to the island, and these, after extinguishing the rats, became so numerous that dogs and shot guns were brought to destroy them. Rabbits were then imported once more, and again became numerous; but were exterminated a second time by snowy owls.

The absence of ledges and boulders suggests that this strip of loose sand is only the vanishing remnant of a long bar, formed by wash from some larger island of glacial drift, now destroyed.

THE PHYSICAL FEATURES OF MAURITIUS.

'The physical features and geology of Mauritius' are described by H. deH. Haig (*Quart. Journ. Geol. Soc.*, London, li, 1895, 463-471). In crossing the lava slopes of the island, one comes without warning on immense ravines, worn to depths of over a thousand feet by the rapid streams, fed by

the moist trade winds. There are few lakes; two occur in old craters, besides various shore lagoons and many marshes and pools among the newer lava beds. Long caves leading underground streams are very common in the fresh lavas. One extensive tubular cavern in solid lava, like a great railway tunnel, measured thirty feet in width and height, and was followed for a mile and a half without reaching its end; bubbly lava drops remain on its roof and walls. The writer accepts the current explanation that these caves are caused by the continued flow of the still molten central part of a lava stream after the surface has hardened and after the supply from above has ceased. Where cavern roofs have partly fallen in, the remnants form natural bridges, of which there are many examples. The most remarkable old cavern now appears as a strange dry ravine, a mile and a half in length, with vertical walls eighty feet high; the roof, having for the most part fallen in bodily, now lies on the floor of the ravine, where the ripple-marked lava surface may still be seen; but every few hundred yards parts of the roof still remain as bridges. In one case a cavern roof was burst upward by the rise of its torrent, fed by the heavy rainfall of the hurricane of February, 1876.

W. M. DAVIS.

HARVARD UNIVERSITY.

CURRENT NOTES ON ANTHROPOLOGY (XVII).

THE CRADLE OF MAYAN CULTURE.

The results of Mr. Mercer's explorations of the caves of Yucatan (see *SCIENCE*, p. 766) corroborate in a noteworthy manner the studies of the Mayan MSS. and art relics. The cave-hunters discovered no trace of a culture lower than that of the historic Mayas. These, therefore, came into the peninsula already semi-civilized. The acute analyst of Mayan art, Dr. P. Schellhas reached some years ago the same

conclusion, and repeats it with added evidence in the *Internationales Archiv für Ethnographie* (Bd. VIII., Heft. III., 1895). The cradle of Mayan culture, he maintains, was south of the peninsula of Yucatan and in the interior. The subject which leads up to his statement is offered by the decorations on some ancient earthenware vases from Guatemala, which are described and portrayed.

Basing an article on a similar series of pottery from the same district, Dr. E. Selser, in the *Verhandlungen of the Museum of Ethnography of Berlin*, points out that throughout western Guatemala, Quirgua probably included, the fictile art and the decorative designs have such close analogies that all this territory must have been under the immediate influence of the cultured nation whose highest products we see in the remains at Copan. The question now presents itself, was it about Copan, in the extreme east of the Mayan territory, or about Palenque and Ocoingo, in its western extremity, that this culture had its origin?

ANCIENT MEXICAN HIGHWAYS.

In a lecture delivered last August before the German Anthropological Society (reported in the *Correspondenz-blatt*, September), Baron von Brackel described several highways constructed by the ancient inhabitants in western Michoacan. They are six or seven feet wide, laid with unhewn large stones, the surface slightly shelving so as to shed the water freely, protected by stone facing, both above and below, where there is danger of the banks giving way. Their direction is almost rectilinear, and evidently the deep ravines and water courses were crossed by hanging bridges, as the road continues either side of them. The paving was so thoroughly done that many miles of it are in perfect condition.

Although in many parts the stones have been taken away for modern constructions,

the speaker believed that it would not be difficult to trace out and map the whole system of these highways. As far as he had accomplished this, they appear to center toward some distant point, which he thinks may be the Bay of Maruata, on the Pacific coast. The vicinity of Coacomán, where these highways are especially noticeable, is rich in copper and other minerals, and the idea suggests itself that these paved paths were built to facilitate the transportation of such materials to the seashore.

D. G. BRINTON.

SCIENTIFIC NOTES AND NEWS.

HARVARD COLLEGE OBSERVATORY.

PROF. E. C. PICKERING announces in circular No. 3, the discovery of a new variable star of the Algol type. The star B. D. + 17° 4367, magn. 9.1, whose approximate position for 1900 is in R. A. 20^h 33^m.1, December + 17° 56', appears to be a variable star of the Algol type. On July 18, 1895, Miss Louisa D. Wells found that no trace of this star appeared on the photograph I 4359, taken with the 8 inch Draper telescope on September 26, 1891, exposure 16 m. On 71 other plates taken from June 30, 1890, to October 5, 1895, the star appears of its normal brightness. On December 12, 1895, at 10^h 42^m Greenwich Mean Time, Prof. Arthur Searle, who had watched this star on several nights, found it more than a magnitude fainter than usual. During the next half hour it diminished about half a magnitude more. Meanwhile, a photograph taken with the 8 inch Draper telescope, I 14036, confirmed the diminution in light. Unfortunately, at 11^h 15^m G. M. T., clouds covered the region, and the star, although carefully looked for, was not seen again that evening. The change in brightness appears to be rapid and the range of variation to be large, exceeding two magnitudes. The nearest bright star is B. D. + 17° 4370, magn. 7.0, which follows 1.4^s and is south 1'. The variability of B. D. + 17° 4370 has been suspected by Espin (*English Mechanic*, Vol. LXII., 334) and also independently by Mrs. Fleming in 1890.

SWEDISH MARINE ZOOLOGICAL STATION.

THE December number of *Natural Science* contains an interesting account, by Mr. F. A. Bather, of a visit to the Marine Zoological Station at Kristineberg, on the Island of Skaftö, Sweden, on the south side of the Gullmar-fjord. The fjord cuts deep into the land, and has a varying bottom of clay, gravel, rock, *Zostera*, algae, shells and mud; immediately outside Kristineberg it reaches a depth of thirty fathoms, and six miles further up a little over eighty fathoms. A number of rocky islands shelter the mouth of the fjord against the sea. Animal and vegetable life are richly represented and provide a boundless field for research.

The station was established in 1877 through the efforts of Sven Lovén. The initial endowment was the sum of \$15,000 bequeathed by Anders Fredrik Regnell to the Royal Academy of Science in order to found a Zoological Station that should belong to the Academy. The Swedish government placed \$2,775 and a gunboat completely equipped at the disposal of Sven Lovén during the summers 1877-9 to facilitate the study of the animal life of the Swedish seas, and this aided greatly in the first development of the station.

The laboratory provides working rooms for ten persons exclusive of the common room. It is furnished with aquaria and all necessary apparatus and supplies. The station is only open during the three summer months, as lack of funds (the yearly appropriation granted by the government is but \$550) does not permit it to be open at other times. For the same reason foreign students are not admitted. The students at the station are provided with work tables and all necessary appliances without charge, with no further expenses than those for board and lodging, which would amount to about \$18 a month.

Mr. Bather suggests that the station might with advantage be opened to foreign students who would gladly pay for the privilege of studying at Kristineberg. Under the present arrangement the student loses the great advantage of free intercourse with his colleagues from other countries.

'TIMBER.'

BULLETIN No. 10, of the Division of Forestry, of the U. S. Department of Agriculture, contains a discussion of the characteristics and properties of wood by Mr. Filibert Roth. The monograph enters into details concerning the weight, moisture, shrinkage, mechanical and chemical properties of wood, its durability and decay. It points out how different kinds of wood may be distinguished, and concludes with a list of the more important woods of the United States. In the introduction Mr. B. E. Fernow, Chief of the Division of Forestry, emphasizes the fact that, although wood has been in use so long and so universally, there still exists a remarkable lack of knowledge regarding its nature in detail, not only among laymen, but among those who might be expected to know its properties; as a consequence, the practice is often faulty and wasteful in the manner of its use, and Mr. Fernow indicates ways in which it may be used to advantage.

Mr. Fernow says that "wood is now, has ever been, and will continue to be, the most widely useful material of construction. It has been at the base of all material civilization. In spite of all the substitutes for it in the shape of metal, stone and other materials, the consumption of wood in civilized countries has never decreased; nay, applications in new directions have increased its use beyond the saving effected by the substitutes. Thus, in England, the *per capita* consumption has increased in the last fifty years more than double, a fact which is especially notable, as the bulk of the timber used there must be imported, while iron and coal are plentiful in Great Britain. In the United States we can only estimate from the partial data furnished by census returns. By these we find the *per capita* consumption to have increased for every decade since 1860 at the rate of from 20 to 25 per cent. There is no country in which wood is more lavishly used than in the United States, and none in which nature has more bountifully provided for all reasonable requirements. In the absence of proper efforts to secure reproduction, the most valuable kinds are rapidly being decimated, and the necessity of a more rational and careful use of what remains is clearly apparent. By

greater care in selection; however, not only can the duration of the supply be extended, but more satisfactory results will accrue from its use."

GENERAL.

THE Results of the motorcycle contest promoted by the *Times-Herald* of Chicago are more hopeful in promise than in performance. When the prizes were offered on July 11 there were only known to be three self-driven road vehicles in the United States, but there were about seventy-five entries for the contest on November 2. As the time drew near, however, it became evident that only a small part of the vehicles would be ready. The contest was consequently postponed until November 28, but a purse of \$500 was offered for a preliminary race on November 2. The only two wagons to start were the Durea and the Benz-Müller, both gasoline motors, and only the latter completed the course of 92 miles, which it accomplished in 9 h., 30 min. On November 28, after snow and on roads as bad as possible, six contestants started, four with gasoline motors and two with storage batteries, but only the two wagons mentioned above completed the course.

WE learn from the *American Naturalist* that the Australian Museum at Sydney still suffers from small appropriations by Parliament, and during the year 1894 it was working with a reduced staff and with practically no money for increase or publication. Dr. Ramsay, owing to ill health, has resigned his position as curator after 20 years' service, but still retains a connection with the Museum. Mr. Robert Etheridge, Jr., has been appointed as his successor. The total income for the year 1895 was about £6,000. 120,000 persons visited the museum during the year, 34,000 coming on Sundays. Among the most interesting additions to the museum were a number of relics of Capt. Cook, the list of which would seem to indicate that this antipodal museum has about as large a collection of specimens collected by Capt. Cook and of memorials of him as has the museum at Oxford. The museum has also received a considerable collection of aboriginal pottery from Arkansas.

TWENTY-SIX fellows and foreign members of the Royal Society died during the year preced-

ing the recent anniversary meeting. It is perhaps worthy of note that the average age of these distinguished men of science at the time of their death was 76.8 years, which is far beyond the average. This is in part due to the fact that members are not elected to the Royal Society at an early age, but it indicates that scientific pursuits are conducive to a long life. Three members lived respectively to 95, 97 and 98, and eleven were over eighty years of age.

MR. M. S. BEBB, known for his researches and publications upon American Willows, died at San Bernardino, California, on December 5, at the age of 62 years. Mr. Bebb had published numerous and important papers on the genus *Salix*, and was preparing a monograph on the subject at the time of his death.

WE have received from Prof. Elisée Reclus a pamphlet describing his plan for the construction of a terrestrial globe on the scale of 1 : 100,000. This globe would have a circumference of about 400 metres, and elevations of 1 kilometer would be represented by 1 centimeter. It is proposed to cover the globe with a second globe for protection, this to be painted on the outside so that the large features may be seen at a distance. M. Reclus believes that such a globe would promote geographical discovery and topographical knowledge. It should be erected in the neighborhood of London, New York or Paris, and would cost about \$4,000,000 (!), apart from the details of the relief.

WORK is now being commenced for the first time on the coal fields of Newfoundland. Cook announced to the Royal Society as long ago as 1766 that he had discovered coal on the island, and several workable seams of coal have been discovered and explored by Mr. J. P. Howley, director of the Geological Survey of Newfoundland. Newfoundland has important copper mines (it is eighth among the copper producing countries of the world), iron mines, etc., and the discovery of coal adds greatly to the productiveness of the mines and manufactures of the island.

THE Field Columbian Museum of Chicago has issued the first number of a series of Botanical Monographs (56 800 pp. and an index), which is entitled 'Contribution to the Flora of

Yucatan,' by Charles Frederick Millsbaugh. The collection which forms the basis of this monograph was made last January, during an expedition to the ruined city of Chichen Itza, and the Islands of Mugeris and Cozumel, and is, according to the author, incomplete and fragmentary, on account of the excessive dryness of the season and the rapidity of movement of the party. The expedition was generously planned and carried forward by Mr. Allison V. Armour, of Chicago, and as it was conducted in his steam yacht it gave an opportunity of visiting the islands that would otherwise have been unattainable. In order that the work should be made as complete as possible, a careful compilation was made of all the publications concerning previous collections.

A SIMILAR report, by Mr. John M. Holzinger, has been issued by the U. S. National Herbarium of the Department of Agriculture, on a collection of plants made by J. H. Sandberg and assistants principally in northern Idaho, but to some extent in the adjacent parts of Washington and Montana, in the year 1892. The monograph contains 287 pages and includes a catalogue of species and a list of 1272 specimens obtained on the expedition. An index is appended.

ARRANGEMENTS have been made with the Metropolitan Telephone and Telegraph Company of New York by which the Weather Bureau will transmit information regarding weather forecasts to the general public. Any one may hereafter call for answers to special questions at any time and be sure of an immediate answer. Moreover, any subscriber who wishes to have all important weather news can send his name to the telephone company, and he will thereafter be telephoned by them whenever any marked change is expected.

At the Annual Meeting of the Royal Society of Edinburgh, which took place on November 25th, the following officers were elected: President, Lord Kelvin; Vice-Presidents, Prof. Copeland, Prof. James Geikie, the Hon. Lord Maclaren, the Rev. Prof. Flint, Prof. J. G. McKendrick and Prof. Chrystal; General Secretary, Prof. P. G. Tait; Secretaries to Ordinary Meetings, Prof. Crum Brown and Mr.

John Murray; Treasurer, Mr. Philip R. D. MacLagan; Curator of Library and Museum, Mr. Alexander Buchan.

WE learn from the American Geologist of the death, on October 27th, of Antonio del Castillo, director of the Mexican Geological Commission.

THE death is announced of Rev. A. E. Philimore Gray, of Wallasey, England, a well-known authority on antiquarian and archaeological subjects. He was elected a Fellow of the Society of Antiquarians in 1887.

THE annual meetings of the American Economical Association under the presidency of Prof. John B. Clark of Columbia College, and of the Political Science Association of the Central States, under the presidency of Prof. Albion W. Small of the University of Chicago, will be held at Indianapolis beginning on December 27th and continuing until January 2d. The first-named association will hold sessions on December 27th, 28th and 30th, and the latter on December 30th and January 1st and 2d. The program for December 31st is a joint one.

SENATOR SQUIRE introduced in the Senate on December 10th a bill providing for the increase of members of the engineer corps of the navy to 303, and providing for the teaching of naval engineering in properly qualified technological schools.

At the eleventh annual dinner of the London Institution of Electrical Engineers, on December 13th, speeches were made by the president, Mr. R. E. Compton, the Duke of Cambridge, and others. Sir J. Crichton Browne said that electrical engineers had added enormously to those nervous diseases with which he and his colleagues had to deal. Their discoveries had increased the strain and stress of existence, and had contributed to those wear and tear diseases that were one of the features of modern civilization.

PROFESSOR W. A. HERDMAN delivered a lecture on 'The Culture of the Edible Oyster' before the Malacological Society of London on December 12th. The lecture dealt with the cultivation of the oyster and chiefly with its cultivation in France. Among the important

features of the French system is that of devoting certain places to one stage of the work, and other places to other stages. From Archachon, for example, after being cultivated up to the age of about two years, the oysters are brought up for further advancement elsewhere and for fattening for the market. Prof. Herdman gave a warning in regard to the fat green oysters, the green in some cases being simply a disease, in which the true blue had got mixed up with the yellow. He remarked that the oyster cultivators, in drawing off the water periodically, trained the oyster to keep its mouth shut when out of the water, which is a point of some importance when it comes to be laid out in the market. The Italian method of culture differed from the French, inasmuch as the former is conducted on the vertical principles, by suspension of the oyster with ropes or twigs in deeper water, whilst the French method is the horizontal, in shallow beds from a few inches to a couple of feet deep. The oyster is said to live as long as twenty years, and those fittest for the market are of the age of about five years. Prof. Herdman stated that the American oyster is more prolific than the English oyster, producing as many as 60,000,000 ova at a time. The typhoid germ does not flourish in sea water at an ordinary temperature, but the question of typhoid fever, as propagated by oysters, is under Government investigation and is not yet settled.

UNIVERSITY AND EDUCATIONAL NEWS.

It is reported that \$300,000 of the \$1,000,000 given by Miss Culver, to the University of Chicago, will be used for the erection of a laboratory of biology on the grounds of the University. An Inland biological station will probably be erected near the Yerkes Observatory on Lake Geneva, and the Marine Biological Laboratory at Woods Holl will be strengthened. About one-half of the entire sum is to be reserved for endowment. The buildings and endowments are, whenever it is suitable, to be named after Mr. Hull, from whom Miss Culver inherited the money.

MRS. MARTHA W. BROWN, of Manchester, N. Y., bequeaths to Dartmouth College a sum of

money to be left to accumulate until it reaches \$40,000, when it is to be used to endow the chair of Physiology to be called 'The William Brown Professorship of Human Physiology.'

DR. CHARLES PALACHE has been appointed assistant in mineralogy at Harvard University. Dr. Palache received the degree of B.S. from the University of California in 1891, was fellow in mineralogy there in 1892-93 and honorary fellow in 1893-94, received the degree of Ph. D. in 1894, and has spent the last year in advanced work at Göttingen.

WE have received from the Missouri Botanical Garden an announcement concerning garden pupils and garden scholarships. Three scholarships will be awarded by the director prior to the first of April next, and applications should be made not later than March 1st. The value of the scholarships is for the first year \$200, for the second \$250, and for the third and fourth years \$300, together with free lodgings.

THERE are said to be 2,610 medical students attending the several schools at Philadelphia; of these 900 are at the University of Pennsylvania and 725 at the Jefferson Medical College.

THE Herbarium of the University of Wisconsin is making special efforts to collect all plants that grow in the State. Mr. L. S. Cheney has been for several years in charge of the field and herbarium work of the Botanical Survey of Wisconsin, and has already examined the plants of the Wisconsin River Valley from the headwaters to the Dells. Prof. Barnes believes that the function of State collections should be to represent the local fauna and flora, leaving the accumulation and maintenance of great collections to institutions which are established or endowed for this purpose, where proper provision can be made for their use.

LADY HERSCHEL has placed copies of observations made at the Cape of Good Hope by the late Sir J. F. W. Herschel, Bart., at the disposal of the trustees of the Mathematical Scholarships of the University of Oxford, with a request that one copy should be given annually to that candidate for the Senior Scholarship who distinguishes himself most in the part of the examination which relates to astronomy.

At a meeting of the electors to the Waynflete professorship of mineralogy, held at Magdalen College on December 13th, Mr. Henry A. Miers, M.A., Trinity College, was elected professor in the place of Prof. Story-Maskelyne, resigned. The emoluments of the professorship are £500 per annum, of which £400 is from Magdalen College and £100 from the University chest.

DISCUSSION AND CORRESPONDENCE.

AN EASY METHOD OF MAKING LINE DRAWINGS.

It is often difficult to get satisfactory cuts of apparatus or of natural objects to illustrate scientific articles. A half-tone, although the easiest to get, is somewhat expensive and liable to be poorly printed, and, on account of its vagueness of outline, is in many cases not as good for scientific purposes as a half diagrammatic line drawing. To get a cheap cut that can be printed on a newspaper press the original photograph must be redrawn in lines and dots. But not everyone has the time and skill to make an accurate line drawing, while if the photograph is sent off to a professional draftsman the expense is about the same as for a half-tone, and the drawing frequently fails to bring out the very point to be illustrated.

A line drawing with the accuracy of a photograph can, however, be easily made in this way: photograph the object, take from the negative a pale blueprint, on the blueprint trace the outlines with as much detail as desired using a crowquill pen and waterproof ink, put the print in water containing a few drops of ammonia, when the blueprint will fade away leaving the black lines on white ground, wash and dry, make such alternation or additions as are required, and the drawing is ready for reproduction by the zinc etching or other process. Of course if the photograph is several times larger than the cut is to be, the reproduction will be neater.

E. E. SLOSSON.

UNIVERSITY OF WYOMING.

[We are glad to give space to the above, although the method has already been recommended. For an apparently new and in many cases better method cf. Prof. Hallock's note on page 761 of the present volume of SCIENCE. J. McK. C.]

THE MEASUREMENT OF COLORS.

EDITOR OF SCIENCE—*Sir*: Mr. J. W. Lovibond, of Salisbury, mentions in *Nature* that his system of Tintometer glasses is in constant use in many laboratories and manufactories for enabling one to record and to reproduce exactly at a future time any given color; and that the method is so simple that it can be carried out by any intelligent workman. Does anyone know whether these glasses are in use in this country, or whether they can be obtained here?

C. L. F.

SCIENTIFIC LITERATURE.

ON THE STRUCTURE OF PROTOPLASM.*

WHAT is the structure of the most marvelous known substance, protoplasm, 'the physical basis of life,' is a question that has long waited its final answer. Probably the best solution thus far given is that found by Prof. Bütschli in the work imperfectly represented in what follows:

That the watery, jelly-like material we find in the most actively living parts of all plants and animals has any discoverable structure is by no means self-evident, and it is only by slow, uncertain steps that the conception of a visible physical structure in this soft living matter has become generally accepted.

The idea that protoplasm is a structureless, homogeneous fluid early met opposition from many who observed here and there facts that pointed to the existence of apparently solid portions in the protoplasm of various cells.

Remak in 1837 found the axis cylinder of vertebrate nerve fibers made up of very minute fibrils. Frommann in 1867 supposed a fibrillar structure was common to all protoplasm. Striated structures were seen in ciliated cells and in gland cells, while Pflüger in 1869 found fibrillations in liver cells.

The fibrils were then seen to be connected in the form of a reticulum. Thus Kùpffer in 1870 describes the living protoplasm of the follicle

*Untersuchungen über mikroskopische Schäume und das Protoplasma. Von O. Bütschli. Leipzig. 1892. 229 pp., 6 pl.

Investigations on Microscopic Foams and on Protoplasma. O. Bütschli. London. Adam and Charles Black. 1894.

cells of *Ascidia* as having a beautiful reticular structure. In 1873 Heitzmann described a reticulum in living *Amœba*, and in the same year Frommann saw networks in the living white corpuscles of the crayfish. In 1876 Schwalbe referred the fibrillar appearances of ganglion cells and of nerve fibers to the presence of a reticulum, and a year later Eimer brought the longitudinal striation of ciliated cells into the same group by observing the cross meshes connecting the fibrils.

In 1880, Schmitz supported the universal occurrence of reticular structures amongst plants while Frommann, four years later, found reticular structures in all the protoplasmic objects he examined. He regarded the network, however, not as constantly persisting, but as forming and disappearing. Leydig also found a reticulum everywhere; even the surface of cells was porous. He thought the reticulum was only a supporting part and that the true living substance was in the meshes of this frame-work. Van Beneden referred the reticular appearances to a trellis-work of fibrils in three dimensions of space. Carnoy made many contributions to the evidence for the existence of a network structure in protoplasm while Flemming and Schneider could perceive only the existence of fibrils.

While there was thus growing up a conception that protoplasm was not homogeneous, but that it contained fibrils which might be united to form a net, there were other views as to the structure of protoplasm. One of the strangest was that of Fayod, who, in 1890, from results obtained by injecting vegetable cells with mercury, concluded that protoplasm consists of long, hollow, spirally twisted fibers that are usually twisted to form the walls of hollow strings, which are also twisted. Previously Kùnstler maintained that spherules built up the cell as the cell did the tissue; each spherule had a dense wall and fluid contents, that is, was a vesicle. Much more general, however, was the recognition of granules within the protoplasm. Called microsomes by Hanstein in 1883, these minute specks were sometimes regarded as nodal points in a network, and again as being arranged in rows to make the apparent fibrils and reticulum. Bechamp in 1867 and Martin

in 1882 thought the granules might be living units, but Altmann becomes, from 1886-90, the chief exponent of the view that granules are the chief active, living constituents of protoplasm. In fact, he even supposes that protoplasm may have arisen as a sort of *zoöglea* mass made by granules that at one time led a separate existence, much as bacteria exist to-day!

Although it cannot be denied that in some places protoplasmic bodies appear quite homogeneous in spite of all attempts to analyze them optically yet it is generally conceded at the present day that protoplasm has a structure, that it has fibrillar portions that may be made up of granules or associated with granules, and that in many cases these fibrils are connected so as to present the appearance of a framework or network.

There is, however, another view of the structure of living matter which demands serious consideration as advanced by a most able worker in various fields of protozoan and metazoan morphology. Professor O. Bütschli, of Heidelberg, the well-known author of the comprehensive monograph on the Protozoa in Bronn's *Klassen und Ordnungen*.

As early as 1878 he advanced the opinion that the observed reticular appearance of protoplasm might be but the expression of an alveolar structure, that protoplasm has a froth-like structure. This idea he now supports by an extensive treatise and by several minor papers. In his view, living protoplasm is composed of fluid, or nearly fluid, vesicles filled with a fluid; more like an emulsion than like soapsuds. The walls of the vesicles form a framework or series of partitions that surround closed chambers. It is the optical section of these walls that gives the appearance of a network. The contents of the chambers, or *alveoli*, are spherules of liquid isolated from one another by the vesicle walls or enveloping layers, as are the air bubbles in a mass of froth by the pellicles of the bubbles.

This conception of the structure of protoplasm may justly claim the dignity of a theory of the structure of protoplasm, since it plausibly explains many of the observed optical appearances and also some of the activities of living matter. If an artificial mass is made having this froth-like structure it may present some of

the optical appearances of protoplasm and also in its peculiar movements simulate some of the movements of living matter, while the same physical explanation that applies to the movements of the artificial froth will, it is claimed, apply to the like movements in protoplasm.

The evidence advanced by Prof. Bütschli in support of this foam theory may be conveniently considered under the following four heads: The structure of artificial foams; the observed structure in many forms of living matter; the movements of artificial foams; the movements of protoplasm.

His artificial foam is made by thoroughly mixing in a mortar potassium carbonate with olive oil that has been heated some time. A drop of the oil lather so made is put on a glass slip, covered with a glass cover and then soaked in water; when cleared up with glycerine it is ready to observe under the microscope.

Such an artificial foam is seen under the microscope to be made up of vesicles of oil 1-5 microns in diameter and upwards. They are full of water, alkali, soap and glycerine. The whole mass of foam is fluid and flows under pressure as oil does. Drops of this foam may be kept for four to six weeks before the oil vesicles burst. Some of the characters of these foams most to be emphasized are: That drops may enlarge or diminish by the osmotic action of surrounding liquid; on the surface of a drop, as well as in the interior on surfaces of large intervessel spaces, the minute vesicles or alveoli are arranged in a layer of small chambers quite regular in size, with their contiguous faces at right angles to the free surface (this is Bütschli's 'alveolar border'); alveoli may be arranged in radiating lines apparently by the action of diffusion currents within the drops; fibrous appearances may arise when currents elongate the alveoli so as to extend lines of them in one direction more than in others. Other properties of these remarkable compounds will be considered later in comparing them with protoplasm.

A considerable portion of the work is taken up with a well-illustrated account of the structural appearances seen in the protoplasm of a large number of different organisms. In both living and in preserved protoplasm Prof.

Bütschli demonstrates the almost universal occurrence of a network appearance similar to that caused by the oil vesicles in the artificial foams.

The methods employed consisted in: the use of Zeiss apochromatic objectives 2 mm. Ap. 1.30 and 1.40 with eye pieces 12 and 18; an iron-hæmatoxylin stain made with ferrous acetate and a $\frac{1}{2}$ % aqueous solution of hæmatoxylin; an acid hæmatoxylin made by adding acetic acid to dilute Delafield's hæmatoxylin; cutting sections one micron thick and studying them, often, in water instead of in balsam.

Though no adequate idea of this net appearance can be given without illustrations, a review of the organisms in which the author has found it may at least show the universal nature of its occurrence. Among the Protozoa the group Suctoria was examined in the representative form *Podophyra* and a meshwork found in the nucleus and in the body of the cell while alive. An alveolar layer was also seen. The group of Ciliata show the network—living *Vorticella*, *Paramœcium*, *Stylonychia*, and in the dead stalks of *Zoothamnium*. In the Flagellata living *Chilomonas*, in the Radiolaria preserved *Thalassicolla*, and in the Heliozoa living *Actinosphæria* and *Actinophrys sol* all show the reticular appearances. *Amœbæ*, both living and prepared, show the characteristic network appearances, while amongst the marine Rhizopods with calcareous shells, drops of viscid protoplasm crushed out from living *Miliolida* show an alveolar border; in living *Gromia* the transition from reticular to apparently homogeneous protoplasm can be well seen in the remarkable pseudopodia.

Leaving the Protozoa, we note that in those problematical forms the *Myxomycetes*, a reticulum, as well as the important alveolar layer, are seen in small masses of *Aethalium septicum* fixed by a picrosulphuric-osmic mixture. Preserved *Pelomyxa palustris* also adds to the evidence for the reticular appearances that may be interpreted as foam structure. Among the lower plants bacteria and some *Cyanophycæ* are claimed as presenting a nucleus-like portion with an alveolar border surrounded, in some cases, with protoplasm that presents the same net appearance.

Among the higher plants it is a noteworthy

fact that, in the cells of the stamens of *Tradescantia*, the hairs of the nettle and of *Malva*, where streaming movements of the protoplasm are known in the protoplasmic strands traversing the interior of the cells fine fibril-like structures are seen to be connected into a mesh or net even in the living cells. Does not the foam hypothesis account for these apparent networks in actively streaming protoplasm better than any other? The eggs of different animal groups show also a reticulum. In sections of the eggs of the sea urchin, *Sphaerechinus*, the well known radiated appearances about the centrosomes are seen connected by transverse lines to form a network, or, as it is interpreted, a radial series of alveoli or vesicles extending in all directions from some central vesicles that form the so-called centrosome.

The red blood corpuscles of the frog show a reticulum with marked alveolar border. Networks are seen in the living cells in the branchial epithelium of *Gammarus* and in living epithelia of rotifers; also in the cells of the gizzard and foot glands of rotifers and in the epidermis of the earthworm when preserved. Sections of *Branchiobdella* show reticular appearances in the cells of the peritoneum and epidermis as well as in the cuticle itself. In the same way the cuticles of *Phascolosoma* and of *Distomum* are found to have a reticular structure like that of living protoplasm. Various tissues in the vertebrates show a reticular character; sections of the liver cells of the frog and rabbit, the epithelium of the small intestine of the rabbit, macerations of the capillaries in the spinal cord of the calf and of connective tissue in nerves of the frog. Pigment cells in the parenchyma of *Aulostomum* and ganglion cells in the earthworm and in the crayfish again show the same froth-like reticulum. Nerve fibres present special arrangements worthy of consideration; in the teased nerve of the frog there are longitudinal fibrils 6-7 microns apart connected by transverse meshes; similar appearances of elongated meshes in rows are seen in the nerves of the crayfish, rabbit and calf.

In all these cases what is actually seen is but a network appearance and not a foam structure, yet as the artificial mass that seems undoubtedly to have a foam structure presents under the

microscope the same network appearance as that seen in the protoplasm, there is a strong inference that this also is due to an actual foam. The resemblance between the appearances of the artificial foam and protoplasm is well seen in the so-called 'false networks' common to both. When fine granules of india ink are seen in water, or when fine oil drops are shaken in soda and compressed, there is formed a network of triangular meshes by the combination of diffraction rings about the separate spherules. Prof. Bütschli claims that the same 'false network' is seen in sections of liver and in other protoplasmic structures in addition to and on a higher level than the true network caused by the alveoli.

The foam theory assumes that protoplasm is in the fluid or viscid fluid state, but this requires demonstration, since many have held since the time of Brücke that protoplasm contains solid elements as part of its structure. The network is often regarded as a solid portion of the mass. The following considerations, however, tend to establish the fluid nature of protoplasm.

The vacuoles in protozoa are spherical and must hence be surrounded by fluid protoplasm. The flowing together of such vacuoles and their membrane-like envelopes are readily intelligible on the foam theory, but not if we assume that the network is a firm structure. The idea of a firm network involves that of a porous surface and the reformation of a new surface with solid supports when the mass is burst; on the foam theory the alveolar layer of closed vesicles makes the boundary of all surfaces and the laws of fluids reform this surface, however often the mass may be ruptured. The alveolar layer has no explanation on any but the fluid foam theory. This remarkable layer of chambers or vesicles is not a membrane, but a fluid layer, as may be seen in the cell division and conjugation of infusoria; yet it may in some cases be so modified as to become a membrane, or even a cuticle or chitinous shell, as in *Arcella*. The assumption of a fluid foam structure explains the radiated arrangement which the meshes of the network present around the nucleus and vacuoles. The fluid nature of protoplasm is also supported by the fact that gran-

ules occur as a rule only at the nodal points of the net, since when lamp-black is added to foam drops it collects at the nodes between the vesicles. The striated appearances of gland cells seem to indicate a fluid state and the occurrence of diffusion currents. Likewise the radiating appearances seen in dividing cells and caused by rows of meshes (alveoli) are like the lines seen in artificial foams and caused, apparently, by diffusion currents. So much do some of these striations resemble those of the artificial foam that Prof. Bütschli is led to assign diffusion currents as their cause in the case of the striations about the contractile vacuole of an *amœba* during diastole, and of the suns at the poles of the spindle in caryokinesis. The striated appearances in pseudopodia and in strands of streaming protoplasm in plant cells are due to rows of elongated meshes (alveoli), and may be taken as evidence of the fluid nature of the protoplasm since they appear to be rows of vesicles stretched by tension. Similar appearances in nerve fibers offer an obstacle to the idea of the fluid state of protoplasm, for we here have permanently elongated meshes without apparent tension; if their elongation were caused by stretching in growth we would yet have to grant considerable rigidity in the lamellæ or material of the net.

Before considering the movements of foams and of protoplasm we may point out the relationship of the foam theory to those cases of apparently structureless protoplasm that remain for any theory to resolve after the actual observations have reached their limit. In the pseudopodia of *Gromia* and in the ectosarc of *Rhizopoda* there are clear areas of protoplasm without granules, network or other discovered structure. Such apparently structureless protoplasm has been variously interpreted: By Heitzmann as regions where the meshwork is so stretched and attenuated as to be invisible; by Frommann as regions in which the network has become dissolved in the matrix; by Fleming as due to crowding of filaments to the point of indistinguishability, and by Leydig as masses of the hyaloplasm crept out from the framework of spongioplasm. On Bütschli's theory such areas appear structureless because the alveoli are widened with walls so stretched

as to be invisible. The thinness of the walls would make the mass physically more like a solid, and, as a matter of fact, we find such homogeneous protoplasm more rigid or viscid than the distinctly reticular internal parts in rhizopods.

Coming now to the movements of artificial foams as bearing upon the probable structure of protoplasm we find that such foam drops may, under favorable conditions, exhibit movements from place to place, changes in outline and certain internal currents.

The change of place may be in an extreme case as much as .45 mm. in a minute. The change of form consist in outpushings here and there that give the drop a decidedly amoeboid outline that changes considerably in a few minutes' time. Of the internal currents the most interesting are the so-called 'extension currents' that pass out from the interior towards the surface, spread out over the surface and tend to return towards the point of origin. In a small drop there may be thus an axial current moving towards one end, which will be the anterior in progression, while at the other end there is a dead region where particles of india ink, if added to the foam, tend to collect in a stationary state. Such an extension current may die out and be succeeded by another with a different axis. Two drops may run together and acquire a new center of extension currents. In large drops there may be several centers of extension currents and each runs out into a pseudopodium-like outpushing of the mass. As one center of streaming dies down and another appears the outline of the large drop changes as above mentioned.

Such streaming currents may continue to exhibit themselves for a day, in one case for as many as six days. The currents are more active when the drop is heated, and electric shocks may cause change in the direction of movement, wrinkling of the surface and bursting of vesicles in the interior.

The probable explanation of these movements of the artificial foam is to be sought in the phenomena of 'superficial extension currents' that are generated whenever the surface tension of a liquid in air or in another liquid is locally diminished by bringing a spot on its surface in-

to contact with a third liquid which has a lower surface tension than the second liquid. Thus, if a drop of oil in water be brought into contact with weak alkali active currents are set up in the water and in the oil. Now, as the foam is a framework of very minute lamellæ of oil, the meshes of which are filled with a watery liquid containing potassium carbonate and potash soap, we have the conditions necessary for the formation of extension currents and streamings if alveoli burst at the surface and readjustments are made throughout the mass by the aid of diffusion currents and the bursting of internal alveoli.

Whatever the true cause of these movements in the foams their appearance is such as to suggest some of the movements of an amœba and it becomes pertinent to inquire if certain protoplasmic movements may not be the direct physical result of their assumed alveolar or foam structure. The movements of protoplasm are commonly spoken of as due to its contractility, and in an Amœba this contractility has been thought to be located either in the ectosare or in an internal framework. Many, however, have called attention to the fact that the movements of an Amœba and the streamings in a plant cell could not be explained upon any assumed contractility in an internal framework. Hofmeister referred movements of protoplasm to changes in power of imbibition and Sachs elaborated a similar idea. Englemann in 1879 assumed that his minute theoretical particles of protoplasm, inotagmas, changing their state of turgidity passed from an elongated to a spherical form and thus brought about contraction of protoplasm. As late as 1879 older views as to the participation of electrical forces in protoplasmic contraction reappeared in the papers of Felton and of Fol. Leydig, 1885, and others since then have regarded the hyaloplasma, and not the framework, as the essential motile substance.

Surface tension as an element in protoplasmic movements was brought in by Berthold, in 1886, in explaining the streamings in plant cells; while Quincke, in 1888, explained such movements on the basis of extension currents caused by surface tension. Though Quincke's conception of the structure of the plant cell was quite

unlike what has been observed his application of surface tension and of extension currents served as an introduction for Bütschli's explanation of protoplasmic movements.

Professor Bütschli attempts to explain some of the more simple forms of ameboid movement as results of the foam-like structure of protoplasm, and thinks surface tension and extension currents are the essential factors. The axial stream which is found in many Amœbæ passing towards the progressing anterior end to bend and flow back near the surface of the animal is, he thinks, an extension current. The chief differences that he sees between such axial streams and the extension currents in artificial foam is that they endure but a short time and flow back but a short distance in the Amœba. The conditions present in protoplasm may be such as to form extension currents, for, as we assume it to be a framework of liquid not soluble in water enclosing water containing substances in solution, we may suppose changes in surface tension would set up such currents as they do in the manufactured foam drops. There is some evidence that the watery parts of protoplasm are alkaline and it is also probable that fatty compounds may be present in the framework. The bursting of some alveoli at the surface would pour out on to the surface some of the watery contents which will cause a local diminution in surface tension and thus give rise to an extension current. In this way, also, pseudopodia may be formed, here and there, by local extension currents.

This explanation, however, cannot be applied to the formation of the remarkable anastomosing pseudopodia of many Rhizopods, and even where it seems to apply it meets with a severe rebuff in the results of experiments upon *Pelomyxa*. It was found that india ink in the water about a crawling *Pelomyxa* shows currents the reverse of what they are about a drop of liquid exhibiting extension currents, so that the assumption of this simple physical explanation for the movements in an Amœba seems on a very weak footing.

The author, however, thinks that in some way the extension current may perhaps be applied to the explanation of rotation movements in the protoplasm of plants cells, and that even

muscular contraction may be explained along similar lines. On the foam theory the muscle is made up of a mass of polygonal vesicles; if there be chemical changes in the watery contents of many of these in one plane the corresponding changes in surface tension of the walls or lamellæ will produce changes in shape of these polygons, and in the mass a shortening and thickening or muscular contraction!

But all motions are not of this nature, since the movements of certain granules seem to be automatic and not, as is often assumed, merely passive. Yet even these granules may in turn serve to change the surface tension of the lamellæ, and so ultimately contribute to readjustment throughout the mass.

In conclusion we may venture to affirm that the foam theory at present falls short of a physical explanation of any of the activities of protoplasm, yet as an approximation to what may well prove to be the actual structure of protoplasm it cannot be too highly praised.

E. A. ANDREWS.

The Structure of Man. An Index to His Past History. By DR. R. WIEDERSHEIM, Professor in the University of Freiburg in Baden. Translated by H. and M. Bernard. The Translation edited and annotated and a Preface written by G. B. Howes, F. L. S., Professor of Zoölogy, Royal College of Science, London. With 105 Figures in the Text. Macmillan & Co., London and New York. Price \$2.60.

This is an excellent book and should be in the hands of all students of anatomy. We have had in the writings of Huxley, Vogt, Darwin and Haeckel dissertations on the position of man in relation to the lower animals, but no book has appeared so comprehensive in scope, yet so minute in details, as the one before us. It originally appeared in German in 1887, as an academic treatise under the title, '*Der Bau der Menschen.*' The present volume is a translation of the revised and enlarged second edition. The author states that he has prepared it especially for the lay reader, and the editor suggests in the preface that it may be of use to the medical student while engaged in the study of anatomy. The distinguished professor of Freiburg has many admirers in this country, and

his book with the notable additions by the English editor will be made welcome. The following comments are made in no spirit of unkindly criticism. In the 228 pages there occur 235 citations of authors. Many of the statements are without reference, and even when journal or volume is given no uniform plan is pursued, and, often, the year of publication is omitted. The value of this display of learning when the objects of the book are recalled, does not always appear. Prof. Howes has given his numerous citations in bracketed paragraphs. Most of them are from English sources. One would suppose from statements in the preface that *Pithecanthropus* had been discussed by none but British anatomists. Throughout the book French and Italian writers receive little consideration. There is scant allusion to Albrecht, and, so far as we have seen, none to Sutton. No reference is made to the admirable essay of Dr. Frank Baker on the 'Ascent of Man.' Certainly these three writers have contributed in a notable manner to the subject embraced in the general thesis. The value of the writings of other Americans could never be determined by this book. On the homologies of the cusps of the mammalian teeth Röse is followed by Wiedersheim, Forsyth Major by the editor, while Cope, Osborn and Scott shift vaguely across the scene. We note that while the book is designed for medical students and lay readers the relations of vestigial structures to the initiation of morbid processes is not emphasized. The connection between the morphology of the vermiform appendix and the frequency with which this structure becomes a factor in disease is not mentioned. The relation existing between the apex of the lung in the region of the neck and the restriction of rib-protection at this place is dwelt on, but the next and, to our minds, the inevitable step, namely, to account for tubercular deposits in the lung apex by the same statement of facts is not even alluded to. The structure of man cannot be logically separated from the manner in which diseased action is manifested in that structure.

It is curious that from the great wealth of material illustrating atavism in the skull that the author should make nine references to the work by the cousins Sarasin on the Ceylon Ved-

dahs. This is liberal, when it is recalled that these writers confine their observations to thirty-three skulls and a few skeletons.

HARRISON ALLEN.

Evolution in Art, as Illustrated by the Life Histories of Designs. By ALFRED C. HADDON, Professor of Zoölogy in the Royal College of Sciences, Dublin, etc. With 8 plates and 130 figures. 1 vol. 8vo. pp. 364. Price 6 sh. (London, Walter Scott, Ltd. 1895.)

Prof. Haddon is already well and favorably known to students both of art and ethnology by his admirable monograph on 'The Decorative Art of British New Guinea,' published in 1894 by the Royal Irish Academy. The present work may be looked upon as a development of that monograph, extending the principles it embodied to a much wider range of art concepts. He takes, indeed, in his opening chapter the decorative art of New Guinea as an example of the method of study of art in general.

The main body of the book is devoted to the discussion of two questions: 1, the material of which patterns are made, and, 2, the reasons for which objects are decorated. Under the first of these, he points out that the originals of decorative art designs are mainly either natural or artificial objects. For the latter, he adopts the term suggested by Dr. H. C. March, 'skeuomorphs,' from a Greek word signifying utensils, etc.; the former he divides into 'physiomorphs, biomorphs and heteromorphs.' He portrays with a large range of illustration how these objective originals became transferred into æsthetic conceptions, and at times conventionalized quite out of recognition, were we ignorant of the intervening steps.

The reasons for which objects are decorated the author considers to be mainly for the sake of information (scenes, picture writing, etc.) for the love of art itself, for the desire to display wealth and for magic and religion. He gives, among these, but a small field to 'art for art's sake'—if, indeed, any, among primitive people. Yet he does not fail to recognize, what some writers have overlooked, that the æsthetic sentiments are the real and only source of all art products, no matter what else they subserve.

The work closes with a suggestive chapter on

the 'scientific method of studying decorative art,' which deserves the attentive study of all interested either in the history of art or in ethnology. It would be difficult to point to a more satisfactory statement of the subject.

D. G. BRINTON.

The Hill Caves of Yucatan. By HENRY C. MERCER. Philadelphia, J. B. Lippincott Co. 1896. 1 vol., 8vo. Illustrated. Pp. 184. Price, \$2.00.

The sub-title to this book explains its aim with sufficient fullness—'A search for evidence of man's antiquity in the caverns of Central America: being an account of the Corwith expedition of the department of archæology and paleontology of the University of Pennsylvania.' Through the generosity of Mr. Corwith this expedition was fitted out and its results were destined to enrich the institution named. A competent corps of explorers under the direction of Mr. Mercer proceeded to Yucatan last February and examined a large number of caves in the low range of mountains which trends from northwest to southeast, about thirty miles south of Merida. In this immediate vicinity are situated the famous ruined cities of Uxmal, Mani, Mayapan and others. There, if anywhere, we might reasonably expect to find traces of the early art of the natives and the record of the evolution of their culture, if it was developed in the peninsula.

This would be the more certain to be the case on account of a peculiarity of the caves of Yucatan. In many portions, during the dry season, the only sources of the water supply are the springs and basins in these caves; therefore, under present conditions, from the first arrival of man he must have resorted to them daily for months at certain periods. He could not fail to have taken with him and to have left some traces of his visits, stone implements, broken pottery, bones, ashes and charcoal from his fires and the like.

Taking these facts as his guides, Mr. Mercer examined, with the most scrupulous care, layer after layer in several of the most notable caverns which were also sources of water supply. The excavations were conducted under his personal superintendence and every sign of man's

presence and every bone were noted as soon as taken from their sites. In this manner he examined twenty-nine caves, six of which yielded valuable results.

His conclusion from this arduous and extended investigation is that there is no trace of any older or more primitive human visitors to the peninsula than the Mayas in about the stage of culture in which they first became known to the Spaniards.

The animal bones and shells which the expedition brought back were examined by specialists and all proved to belong to existing species. Like the remains of man, there was nothing in them to hint at a great antiquity. This fact, however, suggests that the caves themselves must be of quite modern formation; so, perhaps, the expedition was after all looking in places where it is not possible to find the relics of 'paleolithic' man if they actually are in the peninsula. We cannot, therefore, unreservedly accept the author's dictum (p. 177), 'no earlier inhabitant had preceded the builders of the ruined cities in Yucatan.'

The narrative portion of the volume are pleasantly composed, enlivened not only by an ever-present enthusiasm for the main object, but touched in frequent passages with a quick appreciation of the strange and the beautiful in nature and the odd and humorous in life. Whether archæologist or not, the reader will pass agreeable hours over Mr. Mercer's pages.

Some little criticism must be added on the author's capricious orthography of Maya words. The recognized authority is the dictionary of Pio Perez. That work admits no *s* in the Maya alphabet; but Mr. Mercer employs it freely, as *sitz* for *tsitz*, *spukil* for *xpukil*, *sac* for *zac*, thus confounding three different sounds in one. At other times his forms are incorrect, as *tzat-un-tzat* for *zataan zat*, *coyok* for *cooch*, etc. This occurs also in the Spanish, where he gives *volan* for *volante*, the name of a vehicle. The translations of some of the Maya terms are dubious, but for these he does not assume responsibility.

These, however, are slight blemishes, and the book, with its handsome illustrations, excellent paper and attractive account of travel and exploration, is sure to entertain and instruct every reader.

D. G. BRINTON.

Chemical Experiments Prepared to Accompany Remsen's 'Introduction to the Study of Chemistry.' By IRA REMSEN and WYATT W. RANDALL. New York, Henry Holt & Co. 1895. Price 50 cents.

In this edition of Prof. Remsen's laboratory manual a number of new experiments have been introduced, and the course of study as now arranged covers pretty fully the ground outlined by the Committee on Secondary School Studies of the National Educational Association. Like all of Prof. Remsen's text-books this one is characterized by clearness and precision of statement. The directions for each of the laboratory experiments are carefully worded, and it is difficult to see how students in following them could possibly fail in getting good results.

The course begins with experiments which show the difference between chemical and physical phenomena, then the characteristic properties of chemical compounds as distinguished from mechanical mixtures are studied, and this leads on to a systematic study of the preparation and properties of the more important non-metallic and metallic elements. At the end of the book there is a brief introduction to the methods of qualitative analysis. Two quantitative experiments requiring the student to work with accurate weighing and measuring instruments are given; one of these is the determination of the percentage of oxygen in potassium chlorate, the other the determination of the equivalent of zinc. Nothing serves so well as a few experiments of this kind to impress upon students the significance of the fundamental laws of chemistry. Nearly every one of the laboratory directions is followed by a series of questions, the object of which is to make students think about their work, and to lead them on to draw conclusions from the results that they have obtained. There are no blank pages in the book, and it is expected that a full record of each experiment and the conclusions that have been drawn from it be kept by the student in a separate note-book, and that this note-book be submitted to the teacher from time to time for revision. Another excellent feature is that at the beginning of the directions for each experiment there is a list of all the apparatus and chemicals required for the work.

Students who follow the course of study given in this manual will have a most excellent introduction to chemistry, and teachers in arranging the work for their classes cannot go far astray if they are guided by the experience of one who has been preëminently successful in this line of work.

E. H. KEISER.

SOCIETIES AND ACADEMIES.

BOSTON SOCIETY OF NATURAL HISTORY.

THE Society met November 20; eighty-four persons present. Dr. J. Walter Fewkes, in his paper, 'Some newly discovered Cliff ruins in Arizona,' described, and illustrated with stereopticon views, the early home of the Moquis. The ruins studied were of three types: First, the cave dwellings situated on high bluffs and consisting of series of chambers hewn out with stone implements—these chambers have paved floors but the walls show no trace of masonry; secondly, stone houses built surrounding large crater-like depressions; and, thirdly, two large cliff ruins situated many miles north of Montezuma's Well.

The larger of these two ruins, affording room for 500 people, was four stories in height, with floors supported by beams of pine or cedar. Excavations revealed remnants of cotton cloth, blankets made of feathers, pottery, baskets and ropes made of fibers of century plant. Skeletons found beneath the floors showed the burial customs, and the abundance of stone implements with the absence of metal seemed to prove that the workers belonged to the stone age. The walls covered with symbols, practically identical with those now found in the Moqui houses, gave evidence of formal worship. The second ruin, smaller but better preserved than the first, showed the impressions of the hands of the workmen made at the time of plastering the walls of the rooms; a quantity of corn in the ear was found beneath the floor of this ruin. The cliff houses were probably abandoned before the discovery of the country by the Spaniard, and there is no evidence that the cliff dwellers were a distinct people.

The Society held a regular meeting December 4; eighty-one persons present.

Mr. L. S. Griswold discussed some geographical and geological features of the San Francisco Mountains and the Grand Canyon of the Colorado, describing in some detail the petrified forests. The paper was illustrated by a series of lantern slides.

SAMUEL HENSHAW,
Secretary.

NEW YORK ACADEMY OF SCIENCES.

THE regular business meeting was called to order December 2, 1895.

Prof. N. L. Britton presented the report of the Committee on the Audubon Monument and asked that the committee be discharged. He reported the satisfactory completion of the monument and the placing of the new die, which is guaranteed for at least two years. He announced that after all the expenses of the monument had been paid a balance of \$1,797.25 remained on hand, which the committee therewith turned over to the treasurer of the Academy, together with the following resolution:

Resolved, That after all bills incurred by the committee shall have been paid, the Secretary and Treasurer shall pay over the balance to the Treasurer of the Academy, under the title, 'Audubon Publication Fund,' the interest of which shall be annually devoted to the publication of a memoir on some zoölogical or botanical topic, if a paper suitable for such memoir shall be presented. If no such paper shall be presented during any one year, the interest shall be allowed to accumulate until one is presented. Memoirs published by this fund shall be so designated."

A committee was appointed to audit the accounts of the report.

The Section in Astronomy and Physics then organized, with Prof. Woodward in the chair.

The first paper was by Prof. Harold Jacoby, on 'The Determination of Division Errors in Straight Scales.' The author only read the introduction to the paper and outlined the method. Thereupon, with the permission of the chairman, he read an historical description of the observatory at the Cape of Good Hope.

The second paper was by C. A. Post, on 'Photographs of the Lunar Eclipse of September 3, 1895.' The photographs exhibited were

very beautiful and brought out some interesting points with reference to time of exposure.

The third paper of the evening was by Prof. J. K. Rees, on 'Drawings made by Percival Lowell of the Markings on the Planet Mars.' These drawings corroborate to a very remarkable degree the observations of Schiaparelli.

and indicating the manner in which poisoning is likely to occur. The classification of the poisoning agents is indicated by the appended table. The paper will be printed in full in *The Alumni Journal* of the College of Pharmacy.

H. H. RUSBY,
Recording Secretary.

TABLE EXHIBITING THE POISONOUS PLANTS OF THE VICINITY OF NEW YORK CITY.

| | ROOTS, ETC. | BARKS. | HERBAGE AND LEAVES. | FLOWERS. | FRUITS AND SEEDS. |
|--|--------------------------------|---------------|---------------------|-----------------|-------------------|
| Known powerful poisons liable to occasion accidents. | Phytolacca. | Robinia. | Cicuta. | Convallaria. | The Acteas. |
| | Robinia. | Sambucus. | Tanacetum. | | Cicuta. |
| | Cicuta. | | Datura. | | Conium. |
| | Sambucus. | | Veratrum. | | Solanum tub. |
| | Solanum tub. (some tubers.) | | Aconitum. | | " dul. |
| Known powerful poisons not liable to occasion accidents. | Veratrum. | | Nicotiana. | | Datura. |
| | Convallaria. | | | | Taxus. |
| | | | Ranunculus. | | Ricinus. |
| | Aconitum. | | Clematis. | | Aesculus Pavia. |
| | Podophyllum. | | Prunus. | Sambucus. | Chenopodium amb. |
| Known to be poisonous in minor degree. | Sanguinaria. | | Lobelia inf. | Conium. | Euphorbia. |
| | Chelidonium. | | Absinthium. | Caunabis. | Hyoscyamus. |
| | Iris. | | Convallaria. | Juniperus, etc. | Atropa. |
| | Lepidandra. | | Hyoscyamus. | Taxus. | |
| | Ariseima. | | Atropa. | Chelidonium. | |
| Suspicious. | | | Solanum nig. | | |
| | Climicifuga. | | Nasturtium pal. | | |
| | Actea. | | Viola. | Sambucus. | Sambucus. |
| | Nasturtium Arm. | | Menyanthes. | Kalmia. | Sinapis. |
| | Viola. | | Kalmia. | Pieris. | Juniperus. |
| Suspicious. | Gilena. | | Pieris. | | |
| | Triosteum. | | | | |
| | Ipomoea pand. | | Ailanthus. | Robinia. | Podophyllum. |
| | Apocynum. | Ailanthus. | Lobelia card. | | Ailanthus. |
| | Euphorbia Ip. | Kalmia. | " syph. | | Aesculus Hip. |
| Trillium. | Pieris. | Linaria. | | Prunus. | |
| Asclepias. | Ledum. | Robinia. | | | |
| | Rhododendron. | Chenopodium. | | | |
| | Lachnanthes. | Prunus. | | | |
| | Tephrosia. | Taxus. | | | |
| | | Rhododendron. | | | |

The drawings provoked an animated discussion in which Profs. Mayer, Rees, Post, Jacoby and Hallock took part. The prevailing opinion seemed to be that, although Mr. Lowell deserved much credit for great application and labor, we must await further corroboration before accepting his rather extreme theories.

WILLIAM HALLOCK,
Secretary of Section.

THE TORREY BOTANICAL CLUB.

At the meeting on Wednesday evening, November 27, a lecture was delivered by the undersigned on *The Poisonous Plants of the Vicinity of New York City*, illustrated by colored lantern slides. The subject was treated with special reference to the presentation of evidence proving the poisonous nature of the plants named

GEOLOGICAL CONFERENCE OF HARVARD UNIVERSITY, DECEMBER 3, 1895.

Some Features of Joints. By J. B. WOODWORTH. For several years past the author has been gathering material illustrating the intimate structure of joint-planes. Observations based upon the closely-set joint-planes of the argillites of the Mystic river quarries, near Cambridge, show that there is a type of joint-plane exhibiting on its surface fine divergent lines comparable to the 'percussion rays' of flint chips, and indicating the direction of propagation of the splitting movement which resulted in the formation of the joint. These lines were in the case of the joints, called 'feather fracture.' These apparent rays are simply cross fractures between thin laminae of rocks formed by minute planes of fracture, and some of the typical joint-planes

are made up of combinations of these small joint-planes and the cross fractures. (See Figs. 1 and 2.)

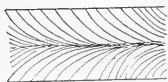

Fig. 1. Feather fracture. The lines diverge towards the margin of the divisional plane.

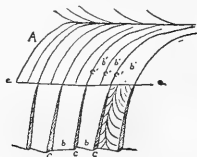

Fig. 2. Ideal arrangement of planes and fractured surfaces. A, principal joint-face; e, e, margin of A; b, b, imbricated planes of fringe; c, c, fractured surface between b-planes; b' b' and c' c', analogous to bb and cc on A, giving rise to feather fracture.' In the b-plane on the right feather fracture is also shown.

The margin of joint-planes of this class frequently dies out in a fringe in which these small joints are much enlarged, the interval between them is increased, and this is accomplished by their being turned at a considerable angle, from 10 to 25 degrees, to the principal joint-plane. These small joints also, where well developed, show feather fracture lines diverging towards the outer margin. Joint-planes are thus complex surfaces of fracture. Over the surface of the large joints the smaller joint-planes become so closely set and so nearly parallel to the principal surface of fracture that these smaller fracture surfaces gradually disappear before the unaided eye and become a mere granulation of the joint surface.

Where these joints are developed in a single stratum, they are commonly in the Mystic River argillite quarries in the form of elongated elliptical planes, the main fracture dying out above and below where the texture of the rock changes parallel with the stratification plane. The fringe of marginal joints then give rise to a set of joints in the underlying and overlying beds having a different direction from that of

the main joint in the intermediate bed. Of less frequent occurrence are discoidal joints, evidently entire joint planes, of small size and circular in area because the stress which produced them was relieved by a small fracture in essentially homogeneous material. These vary

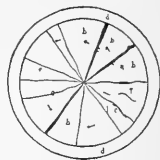

FIG. 3. Discoidal joint, with b-planes and c-fractures analogous to system of fractures in fringe of elliptical joints; d, marginal conchoidal fracture area. Arrows show dip of imbricated b-planes.

from half an inch to three inches in diameter. They consist of the small imbricated planes (b in the diagram) and the cross fractures (c in the figure). The author refrained at the present stage of the investigation from expressing an opinion as to the origin of these joints. The subject was illustrated by typical specimens. These joint structures also occur in the felsites of Salem Harbor, the granitic and dike rocks and in gneisses. A report on the investigation is in preparation.

T. A. JAGGAR, JR.,
Recording Secretary.

NEW BOOKS.

The Cambridge Natural History, Vol. V. Peripatus, ADAM SEDGWICK; *Myriapods*, F. G. SINCLAIR; *Insects*, DAVID SHARP. London and New York, Macmillan & Co. 1895. Pp. xi + 584. \$4.00.

Text-book of the Embryology of Invertebrates. E. KORSCHULT and K. HEIDER. Translated from the German by Edward L. Mark and W. McM. Woodworth. London and New York, Macmillan & Co. 1895. Pp. xv + 484. \$4.00.

Die Spiele der Thiere. KARL GROOS. Jena, Gustav Fischer. 1896. Pp. xvi + 359. M. 6.

Grundzüge der Marinen Tiergeographie. ARNOLD E. ORTMANN. Jena, Gustav Fischer. 1896. Pp. iv + 96. M. 2.50.

SCIENCE.

A WEEKLY JOURNAL DEVOTED TO THE ADVANCEMENT OF SCIENCE.

TERMS OF SUBSCRIPTION.

Five dollars annually in advance: single copies 15 cents. Subscriptions and advertisements should be sent to SCIENCE, 41 North Queen Street, Lancaster, Pa., or 41 East 49th Street, New York.

Foreign subscribers may send their subscriptions direct (\$5.00), or may subscribe and order single numbers through Gustav E. Stechert, London: 30 Wellington Street, Strand, W. C. (£ 1-0-6, single copies 8d). Paris: 76 Rue de Rennes (26 fr., single copies 80c). Leipzig: 10 Hospital Strasse (M. 21, single copies 70 Pf.).

The publisher can supply back volumes of SCIENCE at the regular subscription rates, or for one dollar in addition, if bound. Single copies of nearly all the numbers can also be supplied at the price of 25 cents for numbers earlier than July, 1887, or 15 cents for later numbers.

ADVERTISEMENTS.

Terms may be obtained from the publishers

Advertisements of scientific publications, scientific apparatus and educational institutions are desired as part of the work of the journal. There is no other journal published in America that reaches more directly those who use and recommend scientific books and apparatus.

The demand for back numbers of SCIENCE has been greater than had been foreseen. The publishers will be greatly indebted to any one who may be able to send to 41 East 49th St., New York, copies of the issues of Jan. 25th, Feb. 1st, Feb. 15th, Feb. 22d, March 1st, March 8th, or May 31st, and will extend the time of subscription of any one who will forward these numbers. The publisher would be glad to buy copies of SCIENCE, Old Series, Nos. 478, 491, 513 and 554, and will pay 25 cents each.

THE CONTENTS AND INDEX OF VOLUME II. WILL BE SENT OUT WITH THE ISSUE OF JANUARY 10.

Human Embryology.

By PROF. CHARLES SEDGWICK MINOT,
of the Harvard Medical School.

Royal 8vo, 825 pages, 463 Illustrations, extra musicin, price \$8.00.

This work has been accepted throughout the world as the standard authority on Embryology. The subject is comprehensively presented. Both those aspects of Embryology important to physicians and those interesting to morphologists have been clearly and thoroughly treated. Much of the work is based on unpublished investigations. Most of the illustrations are new.

"We do not know a more learned treatise on any subject whatever."—*Brown-Sequard*.

"It makes a new era in the history of American biological text-books. It is by far the best text-book of the kind."—*C. O. Whitman*.

"Written with all the care necessary to render it a classic."—*Revue Scientifique*.

"A treasure house of Embryological literature."
—*W. His*.

"A rich store of facts and of numerous suggestive explanations."—*A. Milnes Marshall*.

"Each chapter deserves special mention and praise."
—*Montreal Medical Journal*.

"We wish to emphasize the extent to which the author has based his criticisms on his own thorough investigations."—*R. Bonnet*.

"One feature of especial value is the richness of citations of the work of other students."—*American Naturalist*.

William Wood & Co.,

NEW YORK.

The Total Eclipse of the Sun, August 9th, 1896.

The Orient Steam Navigation Company, Ltd., propose to send one of their steamships of about 4000 tons gross register and 3000 H. P., to Vadsø in the Varanger Fiord, Lapland (about 80° E. Long.) to enable observation to be made of the above eclipse.

Itinerary.—Leave London 21st July, visit Odde, Bergen, Naes, Molde, Irondbjæm, Hammerfest, North Cape, arrive Vadsø 3rd August. Leave Vadsø 10th; arrive London 17th August.

Passage money 40 Guineas. Preliminary deposit on booking, £5. Early application is desirable.

Managers.—F. Green & Co.; Anderson, Anderson & Co. Head Offices.—Fenchurch Avenue, London, England. For further particulars apply to the latter firm, 5 Fenchurch Avenue, E. C., or to the West End Branch Office, 16 Cocksspur Street, S. W., London, England.

Zoölogical Specimens

For Class Work and Museum. All material guaranteed.

F. W. Wamsley,
Bridgeton, N. J.

Price-list sent on application.

Nearly all the leading men of science in America have consented to contribute to the New Series of SCIENCE. The contributors include :

- H. P. BOWDITCH, W. M. DAVIS, G. L. GOODALE, W. JAMES, T. A. JAGGAR, JR., C. S. MINOT, HUGO MÜNSTERBERG, F. W. PUTNAM, A. LAWRENCE ROTCH, J. B. WOODWORTH, J. MCM. WOODWORTH—*Harvard University*.
- B. A. GOULD, S. H. SCUDDER—*Cambridge*. HENRY W. HAYNES—*Boston*.
- ALPHEUS HYATT—*Boston University*. SAMUEL HENSHAW—*Boston Society of Natural History*.
- N. L. BRITTON, J. MCK. CATTELL, F. B. CROCKER, WILLIAM HALLOCK, ARTHUR HOLLICK, GILBERT VAN INGEN, H. JACOBY, J. F. KEMP, FREDERICK S. LEE, LEA I. LUQUEER, A. J. MOSES, H. F. OSBORN, M. I. PUPIN, J. K. REES, H. A. TODD, R. S. WOODWARD—*Columbia College*.
- DANIEL W. HERING, MORRIS LOEB—*University of the City of New York*.
- J. A. ALLEN, FRANZ BOAS, A. P. BOSTWICK, H. CARRINGTON BOLTON, E. G. BRITTON, CHARLES L. DANA, EMORY MCCLINTOCK, H. H. RUSBY, DURAND WOODMAN—*New York*. E. L. GREGORY—*Barnard College*. PETER T. AUSTEN, H. H. FIELD, WILLIAM MCMURTRIE—*Brooklyn, N. Y.*
- HARRISON ALLEN, J. S. BILLINGS, D. G. BRINTON, E. D. COPE, JOHN HARSHBERGER, JOHN RYDER, EDGAR F. SMITH, W. P. WILSON—*University of Pennsylvania*.
- R. MEADE BACHE, ROBERT H. BRADBURY, CHARLES S. DOLLEY, PERSIFOR FRAZER, GUY HINSDALE, S. WEIR MITCHELL, G. M. GOULD, WITMER STONE—*Philadelphia*.
- W. K. BROOKS, W. B. CLARK, D. C. GILMAN, ELLIOTT J. GILPIN, W. W. RANDALL, IRA REMSON, E. RENOUF—*Johas Hopkins University*.
- W. H. DALL, G. BROWN GOODE, THEO. GILL, F. A. LUCAS, O. T. MASON, C. V. RILEY, F. H. TRUE—*Smithsonian Institution*. GEORGE M. STERNBERG—*U. S. Army*.
- WHITMAN CROSS, J. S. DILLER, G. K. GILBERT, ROBT. T. HILL, F. H. NEWELL, CHARLES SCHUCHERT, H. W. TURNER, H. N. STOKES, CHAS. D. WALCOTT, LESTER F. WARD—*U. S. Geological Survey*.
- A. HALL, WILLIAM HARKNESS—*U. S. Naval Observatory*.
- ALBERT S. GATSCHEP, W. J. MCGEE, J. W. POWELL—*Bureau of Ethnology*.
- SIMON S. NEWCOMB—*U. S. Nautical Almanac Office*.
- E. B. FERNOW, B. T. GALLOWAY, L. O. HOWARD, F. H. KNOWLTON, C. HART MERRIAM, T. S. PALMER, F. LAMSON SCRIBNER, ERWIN F. SMITH, C. W. STILES, M. B. WAITE, H. W. WILEY—*Department of Agriculture*. J. A. FLEMER, H. G. OGDEN—*Coast and Geodetic Survey*.
- CLEVELAND ABBE, FRANK H. BIGELOW, ALEXANDER MCAIDIE, E. L. MOORE—*Weather Bureau*.
- ELLIOTT COUES, GARDINER G. HUBBARD, J. W. SPENCER—*Washington*. ROBT. B. WARDER—*Howard University*.
- C. E. BEECHER, G. T. LADD, S. L. PENFIELD, E. W. SCRIPTURE—*Yale University*.
- L. H. BAILEY, S. H. GAGE, H. N. OGDEN, E. B. TITCHENER, R. H. THURSTON, BURT G. WILDER—*Cornell University*.
- HORATIO HALE—*Clinton, Ontario*. HENRY MONTGOMERY—*Trinity University*.
- ALEX. F. CHAMBERLAIN, G. STANLEY HALL, E. C. SANFORD, A. G. WEBSTER—*Clark University*.
- J. MARK BALDWIN, WILLIAM LIBBEY, G. MACLOSEKIE, W. B. SCOTT, C. A. YOUNG—*Princeton College*.
- BYRON D. HALSTED, J. B. SMITH—*N. J. Agricultural Experiment Station*. WILLIAM KENT—*Passaic, N. J.*
- W. LE CONTE STEVENS—*Rensselaer Polytechnic Institute*.
- SIR WILLIAM DAWSON, WESLEY MILLS—*McGill University*.
- T. C. MENDENHALL—*Worcester Polytechnic Institute*. S. I. PECK—*Williams College*.
- F. H. GERISH—*Bowdoin College*. H. L. FAIRCHILD—*University of Rochester*. C. W. HARGITT—*Syracuse University*. C. S. PROSSER—*Union College*.
- C. L. HITCHCOCK—*Dartmouth College*. A. C. ARMSTRONG, JR., H. W. CONN—*Wesleyan University*.
- H. C. BUMBUS, E. B. DELABARRE, A. S. PACKARD—*Brown University*. DAVID P. TODD—*Amherst College*.
- EDWARD H. KEISER, T. H. MORGAN—*Bryn Mawr College*. W. F. GANONG—*Smith College*.
- MANSFIELD MERRIMAN—*Lehigh University*. EDWARD HART, J. W. MOORE—*Lafayette College*.
- F. H. HERRICK—*Adelbert College*. JAS. LEVINS HOWE—*Washington and Lee University*.
- WM. M. FONTAINE—*University of Virginia*. JAMES E. KEELER—*Allegheny Observatory*.
- S. A. FORBES—*University of Illinois*. CHARLES ROBERTSON—*Carlinville, Ill.*
- L. A. BAUER, JOSEPH P. IDDINGS, FELIX LENGFELD, ROLLIN D. SALISBURY, FREDERICK STARR—*University of Chicago*.
- HENRY S. CARIART, ASAPH HALL, JR., WARREN P. LOMBARD, J. PLAYFAIR McMURRICK, S. F. PECKHAM, I. C. RUSSELL, ALEXANDER ZIWET—*University of Michigan*.
- WILLIAM TRELEASE—*St. Louis, Mo.* OSCAR HERSHEY—*Galena, Mo.*
- E. S. WHEELER—*Sault Ste Marie, Mich.* CONWAY MACMILLAN, E. W. HALL—*University of Minnesota*.
- U. S. GRANT—*Minnesota Geological Survey*. WARREN UPHAM—*Minneapolis*.
- H. L. BOLLEY—*N. Dak. Agricultural College*. J. C. ARTHUR—*Purdue University*.
- C. R. BARNES, G. C. COMSTOCK, H. L. RUSSELL—*University of Wisconsin*. G. T. WRIGHT—*Oberlin College*.
- THOMAS GRAY, WM. A. NOYES—*Rose Polytechnic Institute*. C. J. HERRICK—*Denison University*.
- GEORGE BRUCE HALSTED, E. T. DUMBLE—*University of Texas*. EUGENE A. SMITH—*University of Alabama*.
- F. H. SNOW, E. S. WILLISTON—*University of Kansas*. PROF. C. S. KNIGHT—*University of Wyoming*.
- DAVID STARR JORDAN, J. C. BRANNER—*Stanford University*. E. S. HOLDEN—*Lick Observatory*.
- ANDREW C. LAWSON, JOSEPH LE CONTE, W. A. SETCHELL—*University of California*.





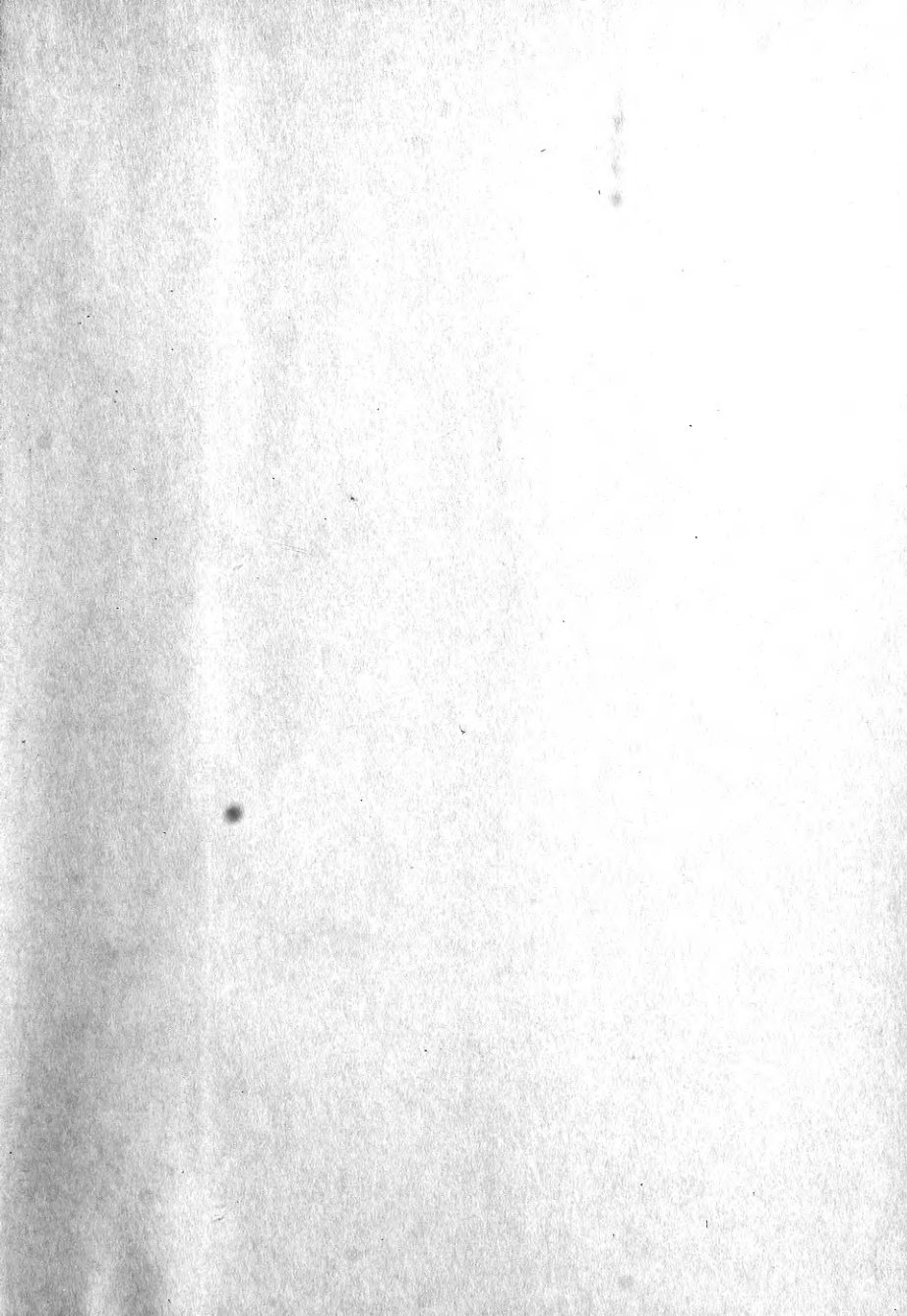

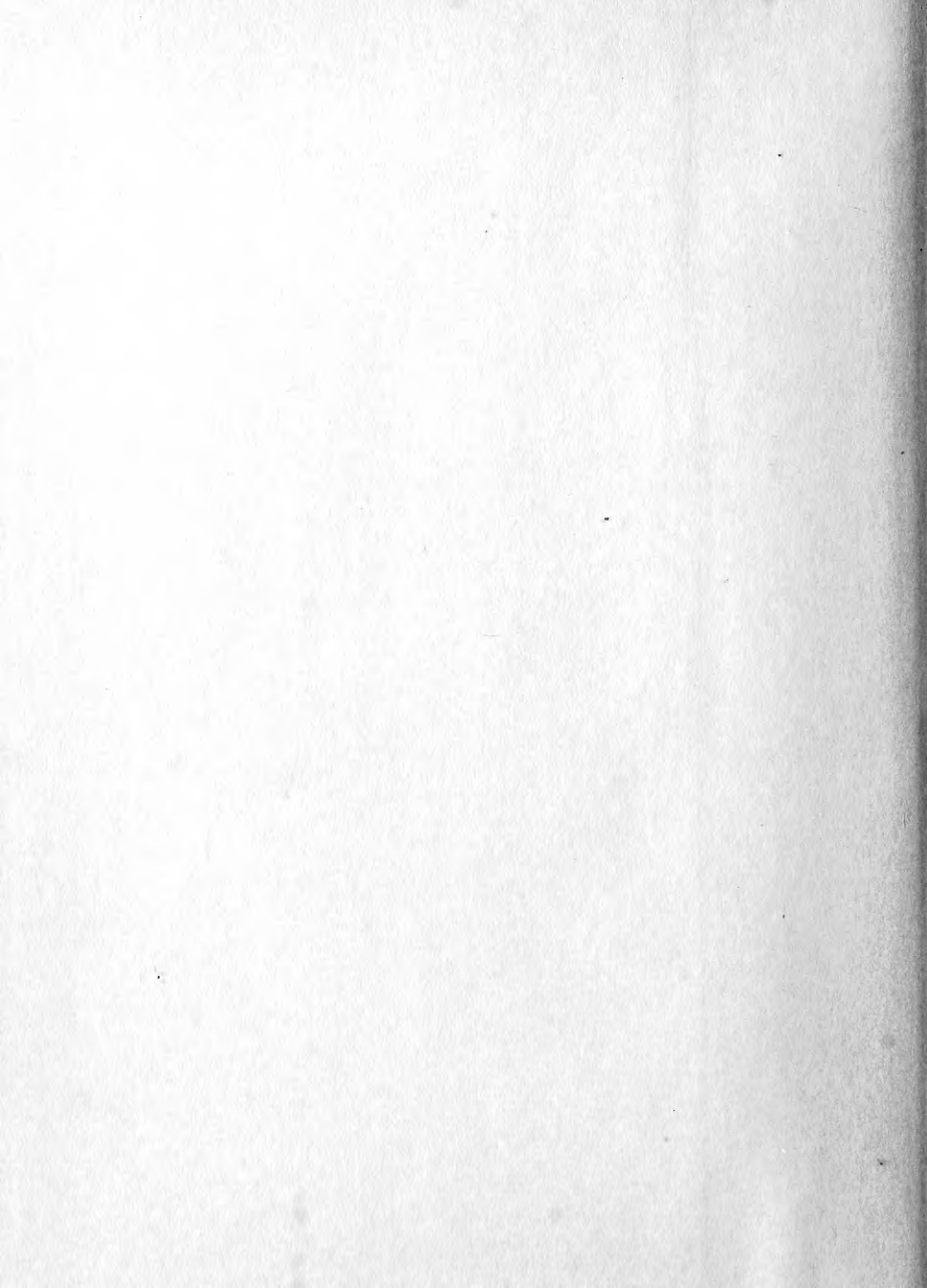

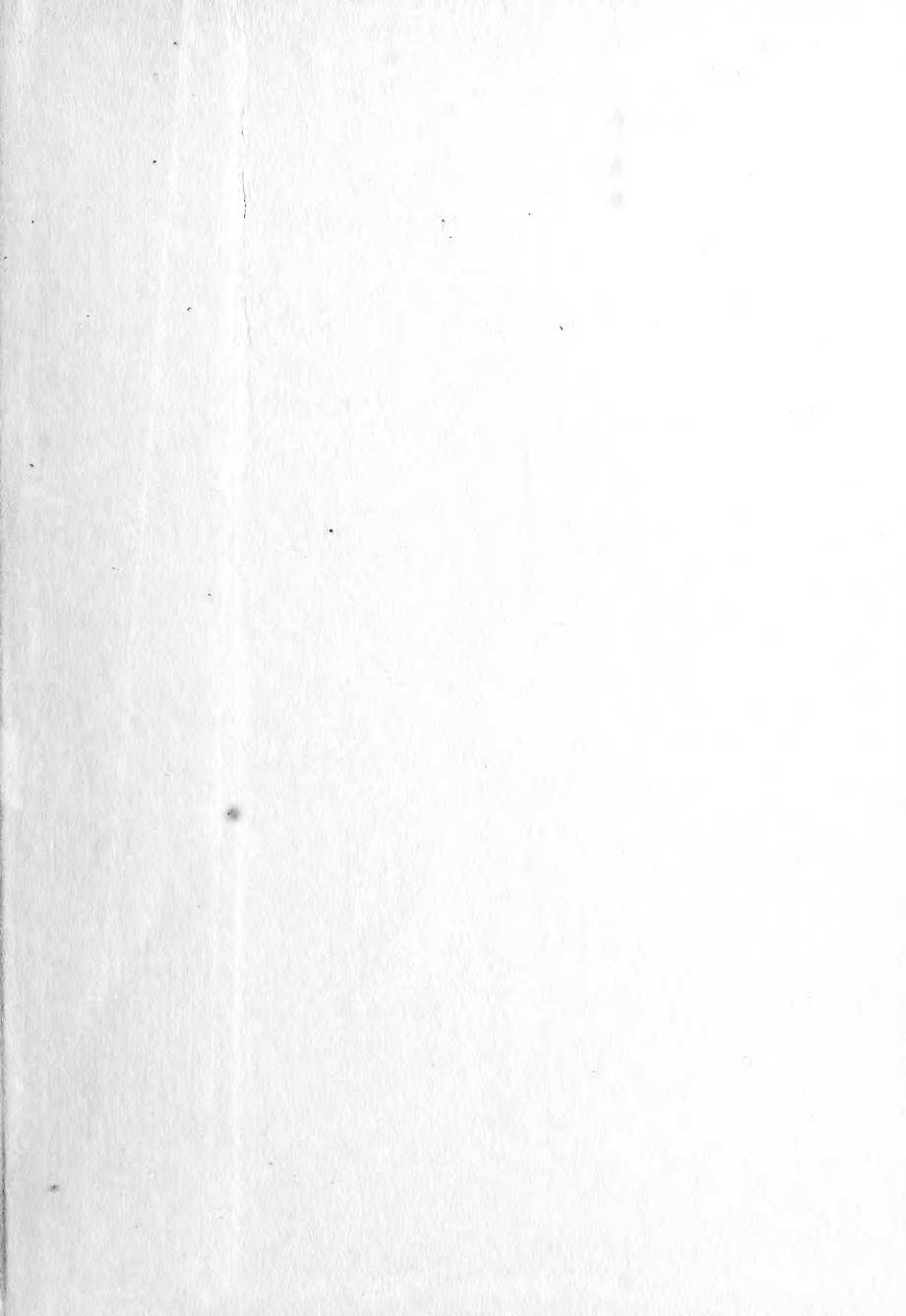

SMITHSONIAN INSTITUTION LIBRARIES



3 9088 01301 4162