



5.06(42) 0

62

61  
-H371  
\*

FOR THE PEOPLE  
FOR EDUCATION  
FOR SCIENCE

LIBRARY  
OF  
THE AMERICAN MUSEUM  
OF  
NATURAL HISTORY

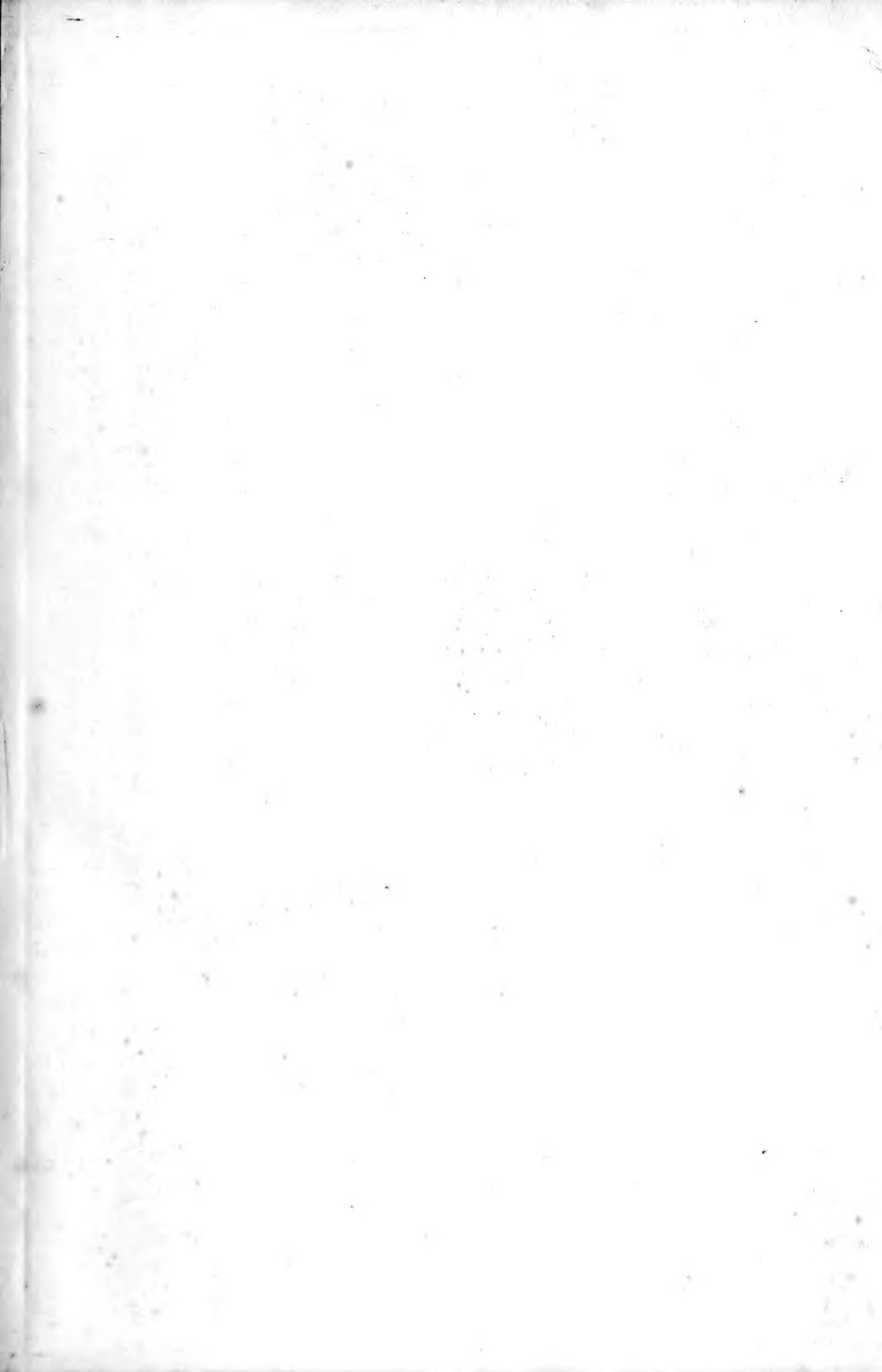

28



LIBRARY  
OF THE  
MUSEUM OF  
COMPARATIVE ZOOLOGY  
AND ANATOMY  
HARVARD UNIVERSITY

# SCIENCE-GOSSIP

5.06(42) U  
03

AN ILLUSTRATED MONTHLY RECORD OF

NATURE AND COUNTRY-LORE

AND

APPLIED SCIENCE

EDITED BY

JOHN T. CARRINGTON

---

VOL. IV.—NEW SERIES

1897-1898

LONDON:

SIMPSON MARSHALL, HAMILTON, KENT & Co., LIMITED

THE NASSAU PRESS

BERLIN: R. FRIEDLÄNDER & SOHN, CARLSTRASSE 11

"IN ORDER THAT KNOWLEDGE MAY BE ACQUIRED, IT IS BEFORE ALL THINGS NECESSARY TO DISTINGUISH BETWEEN THE UNDERSTANDING AND THE IMAGINATION."

—B. de Spinoza, in *Correspondence*, 1666.

"ERROR CONSISTS MAINLY IN WHAT THE POET CALLS 'THE FALSEHOOD OF EXTREMES'—THAT IS, IN ALLOWING ONE OPINION SO TO ABSORB US AS TO TAKE NO ACCOUNT OF ITS OPPOSITE."

—Samuel Laing, in "*Modern Science and Modern Thought*."

25-44650-419

## OUR ANNUAL GREETING.

WE have again to pen an Annual Greeting to our Readers on the conclusion of another year's work. The thanks of the Editor and Publishers are due to the numerous Contributors to the pages of *SCIENCE-GOSSIP*, which in this volume contain so much of value. Thanks are especially tendered to the following gentlemen for the instructive and interesting articles appearing in the present volume from their pens: A. E. Boycott, G. W. Bulman, R. Godfrey, F. J. Gray, G. K. Gude and J. Smith. A special tribute of thanks is also due to J. H. Cooke, F. C. Dennett, E. A. Martin, and the Rev. E. A. Woodruffe-Peacock, who have so generously conducted for the Magazine the respective departments of Microscopy, Astronomy, Geology and Botany; also to Miss Flora Winstone, for interesting contributions under the head of "Science Abroad," and for much general assistance afforded the Editor.

In the new Volume our aim will be to make the pages of *SCIENCE-GOSSIP* still brighter and more entertaining, whilst fully maintaining the instructive and authoritative character of its articles. We therefore hope to receive not only the continued valuable support now given to the Magazine, but extended help, both as to literary contributions and increased subscriptions, so necessary for the improvement of our Journal.

*May, 1898.*

# CONTENTS.

## VOLUME IV.—NEW SERIES.

### CONTRIBUTORS.

- Abbott, G., 272
- Barber, H. J., 71, 85  
Barbour, J. H., 108, 228  
Barham, G., 43, 107  
Barnes, Edward, 358  
Bastin, A. H., 77  
Bechervaise, A. H., 95  
Bell, F. W., 124  
Bladen, W. Wells, 25  
Bowell, E. W. W., 6  
Boycott, A. E., 132, 161, 194, 226, 255, 290, 322, 343  
Briggs, C. A., 272  
Brine, H. C., 299  
Britton, C. E., 59, 122, 129  
Bromley, H., 211  
Brown, G. F., 150  
Bullen, Rev. R. A., 113, 150, 317  
Bulman, G. W., 281, 309  
Burr, M., 123, 136, 188
- Carrington, J. T., 19, 20, 25, 40, 46, 53, 59, 63, 82, 85, 91, 97, 98, 114, 115, 123, 127, 142, 144, 164, 171, 173, 198, 205, 210, 211, 233, 243, 254, 265, 272, 283, 294, 296, 299, 326, 329, 336  
Clarke, A., 124  
Climenson, Emily J., 18, 104, 299  
Cockerell, T. D. A., 25, 45, 229  
Cooke, J. H., 57, 86, 113, 120, 148, 178, 181, 208, 222, 236, 295, 269, 332  
Cooper, J. E., 85, 124, 223
- Dennett, F. C., 23, 49, 51, 83, 119, 147, 177, 207, 239, 267, 297, 331, 339  
Dickson-Bryson, R., 130, 341  
Doncaster, L., 29  
Duncan, F. M., 167
- Edwards, A. M., 253  
Edwards, T., 272, 300  
Eyre, W. L. W., 151
- Flower, Sir W. H., 66  
Flower, S. S., 66
- Garlick, C., 318  
George, C. F., 187  
Godfrey, R., 204, 224, 261, 286, 315, 325, 349  
Gray, F. J., 199, 219, 259  
Greening, L., 123  
Gude, G. K., 10, 36, 70, 102, 138, 170, 231, 263, 284
- Hamilton, W. P., 58, 203  
Henley, A., 25  
Hole, H. A., 151  
Horsley, Rev. J. W., 254, 272
- Jones, H. J. L., 123  
Jones, K. H., 79
- Keegan, Dr. P. O., 236, 292, 300  
Knight, Col. H. S., 258
- Lett, H. W., 151  
Littler, F. M., 358  
Lones, T. E., 58
- Marriott, W., 213  
Marten, C. J., 142, 151, 152  
Martin, E. A., 26, 150, 157, 172, 180, 190, 211, 212, 242, 273, 299, 300, 334, 356  
McIntire, N. E., 25  
Mead-Briggs, T. H., 358  
Meade, R. H., 151  
Meehan, T., 15, 38, 80, 105  
Mercer, Guy, 142  
Morris, S., 243  
Mott, F. T., 61
- Niven, G. W., 155, 305, 364  
Nunney, W. H., 2
- Oswald, F., 4, 74
- Palmer, T. C., 65  
Parritt, W. H., 140  
Peacock, Mabel, 85  
Pepworth, W. H., 163
- Pereira, C. P. A. de L., 217  
Perks, F. P., 85, 152, 211, 358
- Rea, C., 168  
Rollason, W. A., 172  
Rowell, J., 25
- Sauzé, H. A., 13, 124, 364  
Schuster, E. H. J., 307, 345  
Sewell, S. A., 116  
Sheppard, T., 29, 61, 93, 125, 185, 364  
Sich, Frank, junr., 123, 299  
Smith, F. W., 151  
Smith, H. E., 26  
Smith, J., 250, 287, 320  
Soames, Rev. H. A., 150  
Stokes, Dr. A. C., 68  
Stuart, Major, 123  
Swann, H. K., 137  
Symes, Dr. J. O., 100
- Taylor, A. T., 123  
Teasdale, M. J., 243  
Thompson, W., 327  
Tremayne, L. J., 28, 29, 60, 72, 91, 93, 154, 214, 244, 274, 304, 336  
Turner, Creswell, 25  
Turner, E. E., 59, 179, 299  
Turner, G. C., 25, 152  
Turner, H. E., 32  
Turner, H. J., 27, 28, 60, 90, 153, 184, 214, 243, 303, 363
- Vevers, C. C., 301
- Walker, J. W., 152  
Ward, John J., 11  
Webb, J. C., 123  
Welch, R., 47  
Wheldon, J. A., 110  
Whitway, P. and F., 47  
Wilson, Wm., 123  
Winstone, Flora, 22, 52, 89, 117, 146, 182, 213, 241, 274, 277, 302, 317, 335  
Woodruffe-Peacock, Rev. E. A., 59, 152, 183  
Wright, C. E., 336

### ILLUSTRATIONS.

- Acneus*, Antennae of, 87  
*Adrianes*, Antennae of, 87  
*Agriolimnax laevis*, Teeth of, 9  
*Amblyophis viridis*, 346  
Antennae of Coleoptera, Some, 87  
" of Insects, Some, 86  
" of Male Phengodes, 88  
*Arrhenurus buccinator*, 187  
" " female, 187  
" " *festivus*, 187  
" " *zachariae*, 187  
Audubon, J. J. L., 327
- Balsam, Royle's, 319  
Bartlett, A. D., 1  
Blackbird, A Tame, 47  
*Bolboeris*, Antennae of, 87  
*Bulinus decollatus*, 17
- Calcarina candidissima*, Teeth of, 9  
*Caltha palustris*, 11
- Chara*, mounting of, 88  
*Chaulmugra* Fat Crystals, 121, 237  
Chigoe, 361  
" Part of Proboscis of, 361  
" Developing Eggs of, 361  
*Chironomus*, Antennae of, 86  
*Clausilia swinhoeti*, 17  
*Cochlostyla philippinensis*, 17  
*Connulus fulvus*, Teeth of, 9  
*Corymbites*, Antennae of, 87  
*Cribraria violacea*, 361  
*Cypraea arabica*, 16
- Darwin Statue at Shrewsbury, The, 127  
*Dendroides*, Antennae of, 87  
Descending a Big Cliff, 235  
Diatoms, Apparatus for Testing Vegetable Nature of, 65  
Dickson, Baron Oscar, 31  
*Dinestes*, Antennae of, 87  
Dover Colliery, Section of Boring for, 157, 159, 192, 193
- Dust Particles in the Air, 178  
Dyes, Diagram of effect of, 301  
*Erythraea littoralis*, Fries., 110  
" " var. *intermedia*, 110  
" " and *centaurium*, Apex of Sepals, 111  
*Englena acus*, 307  
" *deses*, 307  
" *spirogyra*, 345  
" *viridis*, 307
- Fat Crystals, *Chaulmugra*, 121, 237  
" " Human, 237  
" " of Monkey, 237  
Fern, Swimming, 270  
Flea from Owl, 149  
Freezing-Box and Microscope, Taylor's, 120
- Grouse, Red, 326

CONTENTS.

v

House-Fly, The, 271  
*Hyalinia alliiaria*, Teeth of, 7  
 " *cellaria*, " 7  
 " *nitidula*, " 7  
 " *pura*, " 7  
 Infusoria, British, 307, 345  
*Lachnosterna*, Antennae of, 87  
*Luridus*, Antennae of, 87  
 Marine Telegraph Cable, Broken, 95  
 Mars, Clouds seen on, 258  
*Megalodon ensifer*, 136  
 Microbes in Air of Schoolroom, 179  
 " Atmospheric, 178  
 Micrometer Measuring Apparatus, 333  
 Microscope, New type, 296  
 Mollusca, Odontophores of, 7, 9  
 Mokokoi, or Dried Human Head, 165  
 Moon, The, Map of, 339  
 Mounting *Chara*, System of, 88  
 Mushroom, A Double, 272  
 Naturalist, a Primitive, 247  
*Neuropteris ravineris*, 191  
 " *schaucheri*, 190  
 Obsidian, Microscopic Crystals in, 180  
 " Red, Thin Section of, 180  
 Orange Mite, 209  
*Phacus longicaudus*, 307  
 " *pleuronectes*, 345

*Phacus pyrum*, 345  
 " *triqueter*, 307  
 Photoscope, 50  
 Pigeon, Passenger, 21  
*Plectopyllis biforis*, 103  
 " *blanda*, 264  
 " *brahma*, 170  
 " *diptychia*, 284  
 " *emoriens*, 37  
 " *feddent*, 171  
 " *jovia*, 138  
 " *leucochilus*, 231  
 " *lissochlamys*, 71  
 " *macromphalus*, 10  
 " *magna*, 70  
 " *minor*, 11  
 " *munipurensis*, 263  
 " *murata*, 284  
 " *mispyralis*, 10  
 " *oglet*, 263  
 " *perrieræ*, 232  
 " *phlyaria*, 139  
 " *polyptychia*, 102  
 " *pseudophis*, 170  
 " *quadristi*, 71  
 " *reserata*, 37  
 " *schistoptychia*, 103  
 " *schlumbergeri*, 138  
 " *secura*, 231  
 " *shanensis*, 36  
 " *stenochila* var. *basilia*, 36  
 " *trochospira*, 285  
 " *trochospira* v. *baholensis*, 285  
 " *villedaryi*, 139

*Polita excavata*, Teeth of, 9  
 Pond-sweep, A, 57  
 Prehistoric Man, Remains of, near Mentone, 173  
 Pu Tor, Dartmoor, 55  
*Prionocyphon*, Antennae of, 87  
*Pyralis jarinalis*, 122

Rainbow, Abnormal, 113  
 River Road, The, 265  
 River Valley by a Mountain Stream, 54

Shells, Some Sciagraphs of, 17  
*Stemonitis splendens*, 361  
 Stratford-on-Avon Church, 233  
*Succinea*, 45

Tachea, Two Species of, 133  
*Telesia polyphemus*, Antennae of, 86  
 Te Pehi Kupo, 164  
*Trachelomonas volvocina*, 346  
 " *hispidia*, 346

Unknown Object in Flint, 358

*Vitrina pellucida*, Teeth of, 9

Water-Mites, 187  
 Willow Warbler, Pallas's, 205  
 Wookey Hole Cave, 217, 218

ARTICLES, NOTES, ETC.

ABNORMAL RAINBOW, 113  
 Acetylene Gas: its Value to Scientific Students, 222  
 Aerial Torpedoes, 98  
 After Darwin, 309  
*Agriolimax laevis*, 9  
 Amber: where it is found, 341  
*Amblyophis viridis*, 245  
 American Naturalists; Two Eminent, 293  
 Ants and Aphides, 317  
*Arrhenurus buccinator*, 187  
 " female, 187  
 " *festivus*, 188  
 " *zuchariæ*, 188  
 ASTRONOMY.—23, 51, 83, 119, 147, 177, 207, 239, 267, 297, 331, 359  
 Binary Star, Rapid, 119  
 D'Arrest's Comet, 119  
 Hour-Glass Sea of Mars, 83  
 Jupiter, Satellites of, 83  
 Lick and Greenwich Equatorials, 51  
 Mars, Diameter of, 147  
 Meteor, A Brilliant, 119  
 " A Remarkable, 297  
 Meteors, August, 177  
 " November, 23  
 Moon, The " Second," of the Earth, 297  
 Nebula, A Singular, 331  
 New Observatory for London, 23  
 Perrine's Comet a 1897, 207  
 " Comet b, 1898, 359  
 Photographic Telescope, Thompson's, 119  
 Pons-Winnecke's Comet, 207, 267  
 Potsdam Refractor, Large, 240  
 Red Stars, 23, 51, 83, 119, 147, 177, 207, 239, 267, 297, 331  
 Saturn's Ring System, 177  
 Sun, Parallax of, 267  
 " Object Crossing, 331  
 Sunspot, Group of, March, 359  
 Sunspots, 83  
 Venus, Diameter of, 147  
 Yerkes Great Lens, 51, 359  
 Yerkes Observatory, Dedication, 119  
 Autumn Tints, 292  
 BARTLETT, ABRAHAM DEE, 1  
 Blood as a Microscope Object, 68  
 Bog Flow in Kerry, 112

BOOKS TO READ, 20, 21, 53, 54, 55, 82, 115, 116, 142, 143, 173, 174, 175, 205, 233, 265, 266, 294, 326, 327, 328, 355  
 A B C of the X-Rays, 115  
 Audubon and His Journals, 327  
 Bibliography of Gilbert White, 115  
 Botanical Laboratory, 294  
 British Game Birds and Wild Fowl, 20, 82, 143, 294, 356  
 By Roadside and River, 265  
 Companion for the Queensland Student of Plant Life, 115  
 Concise Knowledge Natural History, 53  
 Critical Period in the Development of the Horse, 174  
 Descriptive Catalogue of Useful Fibre Plants of the World, 175  
 Dictionary of Photography, 53  
 Electricity and Magnetism for Beginners, 82  
 Elementary Chemistry, 356  
 " Physics, 294  
 Entomological Society of Ontario, Annual Report of, 20  
 Essays of George John Romanes, 53  
 Essex Technical Laboratories, Journal of the, 20  
 Evolution of the English Alphabet, 143  
 Experimental Farms of Canada, 294  
 Farm and Garden Insects, 21  
 Fauna and Flora of Radley and the Neighbourhood, 115  
 Field Columbian Museum Report, 328  
 Fishes and Reptiles of Somaliland, 328  
 Flora of the Alps, 20, 143, 266  
 Geology, General, 356  
 " of Indiana, 234  
 Glass Blowing and Working for Amateurs, 294  
 Guide to Zermat and the Matterhorn, 142  
 Handbook of the Birds of Great Britain, 55  
 Handbook of the Order Lepidoptera, 55  
 Harvey, William, Dr., 234  
 Humane Science Lectures, 142  
 Humanitarian Essays, 265  
 Illustrated Manual of British Birds, 205, 265  
 Induction Coil in Practical Work, 51  
 John Hunter, Man of Science, etc., 175  
 Journal of Malacology, 266

BOOKS TO READ—continued.  
 Journals of Walter White, 233  
 Laboratory Arts, 328  
 Lepidoptera of the British Islands, 234  
 Lessons with Plants, 329  
 Machinery of the Universe, 175  
 Medical Botany, 175  
 Memoir of Wm. Pengelly, 173  
 Memory, Cultivation of, 355  
 Mineralogy Geology, 82  
 Missouri Botanical Garden, Annual Report of, 174  
 Nature-Chat, 116  
 Natural History (Vertebrates) of the British Islands, 326  
 Naturalists' Directory, 21, 137, 328  
 New Astronomy, 328  
 " Method of Studying Neuration, 323  
 North American Lemnaceae, 294  
 Orthoptera, British, 356  
 Phylogeny and Taxonomy of Angiosperms, 294  
 Pictorial Instruction Object Lessons, 143  
 Practical Acoustics, 53  
 Publications of the U.S. Department of Agriculture, 115  
 Queensland Aborigines, 328  
 Rambles Round London, 116  
 Royal Natural History, 21  
 Shakespearean Guide to Stratford-on-Avon, 233  
 Short Synopsis of English History, 143  
 Smithsonian Institution, Annual Report of, 143  
 Some Phenomena of Nature, 265  
 Storm and Sunshine in the Dales, 294  
 Story of the British Coinage, 266  
 " Life in the Seas, 326  
 " the Earth's Atmosphere, 20  
 " Germ Life, 171  
 " Photography, 356  
 Text Book of Botany, 355  
 " of Geology, 54  
 Through a Pocket-Lens, 175  
 Tourist Guide to the Continent, 116  
 Transactions of the English Aborigines Society, 266  
 Waste and Repair in Modern Life, 54  
 What is Life? 265  
 With Nature and a Camera, 244  
 Young Beetle-Collector's Handbook, 20

- Botanical Competition, 46, 198, 353  
 " Exhibition, Novel, 46  
 " Notes, 69  
 " Rambles Round Edinburgh, 130
- BOTANY.**—59, 69, 116, 152, 183  
 Abnormal Cowslip, 59  
 " Marsh Marigold, 59  
 Adaptability of Plants, 152  
 Albanism, 183  
*Anchusa sempervirens* in Lincolnshire, 59  
*Anemone appennina* in Essex, 59  
 " *appennina* in Ireland, 59  
 Bladderwort, 152  
 Blue Jacob's Ladder in Somerset, 59  
 Botanical Exchange Club, 59  
 British Grasses, 59  
 Double Flowers, 152  
 Fasciated Daisy, 59  
 " Rose-Stem, 317  
 Hepaticae, British, New List, 116  
 Orchidaceae in Surrey, 25, 59  
 Rare Plants in Lincolnshire, 59  
 Sandhills at Flushing, 116  
 Solomon's Seal in Hants, 59  
*Trifolium filiforme* in Lincolnshire, 59  
*Veronica montana* near Louth, 59  
*Xenodochus carbonaria* in Wales, 152
- British Freshwater Mites, 187  
 " Infusoria, 307, 345  
 " Mosses, 325  
*Bulimus decollatus*, 17
- Calcarina candidissima*, 9  
*Caltha palustris*, 11  
 Casual and Alien Plants in North London, 223  
 Christmas Island, 106  
*Clausilia winthoei*, 17  
 Climate of the Yukon Basin, 335  
 Coal in Kent, 32, 97, 157, 190  
*Cochlostyla philippinensis*, 17  
 Coloration and Variation of British Extra-Marine Mollusca, 161, 194, 226, 255, 290, 322, 343  
 Coloration and Varieties of Mollusca, 254  
 " and Zonulation in *Tachea*, 132  
 Colour of Blood, 4  
 Coming of the Rains, 66  
 Confusion in Nomenclature, 2  
 Congress, Annual, of the South-Eastern Union of Scientific Societies, 42  
*Conium fulvum*, 9  
 Contributions to the Life-Histories of Plants, 15, 38, 80, 105
- CORRESPONDENCE**, 62, 94, 156, 186, 215, 306
- Crystallizations of Fats, 237  
 Crystals, Rings and Brushes of, 236  
*Cypraea arabica*, 16
- DARWIN AT SHREWSBURY**, 127  
 Denton Collection of Butterflies and Moths, 232  
 Dickson, Baron Oscar, 31  
 Disseminating Yeasts, 292  
 Dust, 100
- EARLY MAN IN EGYPT**, 47  
 Earthworms, Destruction of, in Essex, 314  
 Earwigs, 188  
 Eclipse of the Sun, January 22nd, 264  
 Ecology, Rhythmic, in Plants, 39  
*Erythraea*, Variations in, 110  
*Euglena acus*, 308  
 " *desei*, 308  
 " *spirogyra*, 345  
 " *viridis*, 307, 308
- Evolution of the Animal Cell, 250, 287, 320, 347  
**EXCHANGES**, 30, 62, 94, 126, 156, 215, 246, 276, 306  
 Eyes of Insects, 113, 338, 366
- FERMENTATION GERMS: HOW THEY ARE SPREAD**, 222  
 Fern, Swimming, 270  
 Fighting an Insect, 313  
 Flowering of Dead-Nettle, 129  
 Flagellata Eustomata, 307, 345
- Flying Fish, 79  
 Foreign Varieties of British Land and Freshwater Mollusca, 45, 229  
 Fossil Bacillaria in New Jersey, 253
- GEOLOGY**, 150, 180, 181, 212, 242, 273, 300, 334, 357  
 Age of the Earth, 273  
 " Pre-Cambrian Series, 273  
 Ancient Glaciation, 273  
 British Jurassic Brachiopoda, 334  
 Carboniferous Flora, Yorkshire, 357  
 Cause of Ancient Submergence, 273  
 Chalk—Croydon to Oxted, 150  
 " Rock, 334  
 " Challenger" Notes, 357  
 Cheadle Heath Oak, 334  
 Correlation of Ancient Faunas, 212  
 Devizes, Geology of, 242  
 Egyptian Geology, 181  
 Eolithic Implements, 356  
 Erosion in the Nile Valley, 334  
 Evidence of Glaciation, 273  
 Fossil Club Mosses,  
 Foreign Boulders in Chalk, 242, 300  
 " Stones in Chalk, 273  
 Formation of Boulder Clay, 334  
 Geological Dates, 273  
 " Photographs, 283  
 " Records of South-East England, 180  
 Geological Titles of Formations, 242  
 Glacier Garden, 181  
 Gravels of South England, 356  
 Greenland Cretaceous Flora, 150  
 Growth of the Glaciers of the Alps, 181  
 Humus, 242, 300  
 Igneous Fragments in Bagshot Beds, 300  
 Indiana Petroleum, 300  
 Intensity of Glacial Period, 273  
 Interstratified Quartzite, 212  
 London Geological Field Class, 357  
 Manganese Deposits at Harpenden, 25  
 Mediterranean, An American, 212  
 Microlites and Trichites, 180  
 Natural Gas, 300  
 Opal Pseudomorph, 356  
 Palaeontological Review, 181  
 Permanence of Ocean Basins, 242  
 Phosphatic Chalk, 334  
 Pleistocene Beds at Carshalton, 212  
 Pot Holes, 181  
 Prestwich Collection for Forbes, 181  
 Problem of Diamond Making, 180  
 Pyritised Fossils, 242  
 Rate of Denudation, 273  
 " Flow of the Lava Streams of Etna, 181  
 Shale Oil, 357  
 Streatham Water Supply, 357  
 Sussex Pleistocene Cliff-Formation, 212  
 Thurlow Meteorite, 181  
 Triassic Outlier, A Submarine, 357  
 Underground Fuel, 180  
 Village Built on a Boulder, 181  
 Worms, Work of, 357
- GREENWICH OBSERVATORY, ANNUAL VISITATION** of, 49
- HELICOID LANDSHELLS, ARMATURE OF**, 10, 36, 70, 102, 138, 170, 231, 263, 284, 332  
*Heliophytum*, Fecundity of, 38  
*Helix nemoralis* in Ireland, 352  
 " The Virginia Colony of, 67  
 Honey-glands of Flowers, 80  
 How Flowers Attract Insects, 281  
 Humus, 242, 300  
 Hybrids in Nature, 81  
*Hypericum*, Pellucid Dots in, 15
- Infusoria, British, 307, 345
- JACKSON-HARMSWORTH ARCTIC EXPEDITION**, 137  
 June Ramble, 77
- KENT COAL-FIELDS**, 97, 157, 190
- Lamium purpureum*, Flowers and Flowering of, 105  
 Latent Life in Seeds and Microbes, 295  
 Living Lamps, 167
- MAORI TATTOOING**, 164  
 Marine Biological Association, Journal of, 139  
 Marine Fauna at Folkestone, 140  
 Mars, Clouds seen on, 258  
 " Physical State of, 74, 258  
*Megalodon ensifer*, 156
- METEOROLOGY**, 152  
 Immense Meteoric Stone, 152  
 Strasburg Conference, 354  
 Waterspout off Cromer, 152  
 Weather Signs at Whitby, 152  
 Microbes in Air of Schoolroom, 179  
 " Atmospheric, 178  
 Micrometer Measuring Apparatus, 333  
 Microscopical Sections, Making, 260
- MICROSCOPY**, 57, 58, 86, 87, 88, 120, 121, 122, 148, 149, 178, 179, 208, 209, 210, 236, 237, 238, 269, 270, 271, 295, 332, 333, 360  
 Acetylene Gas in Photomicrography, 208  
 Algae, Preservation of, 149  
 Alkaline Glycerine, 209  
*Amoeba villosa*, Sporular Development of, 266  
 Antherozoids of *Zamia*, 271  
 Assimilation of Green Plants, 238  
 Atmospheric Dust, 178  
 Bacteria of Corn, 271  
 " Size of, 333  
 Bactericide, A New, 295  
 Bacterium Living in Alcohol, 149  
 Bird Lice, Economy of, 57  
 Baldness Microbe, 122  
 Balsam, Preparation of, for Mounting, 179  
 Balsam, Tolu, Test for, 238  
 Chaulmugra Fat Crystals, 120  
 Chigoe, The, 360  
 Clearing of Vegetable Microscopical Sections, 237  
 Coccidia, Life Cycle of, 208  
 Colour Reaction, 148  
 Composition of Peat, 332  
 Condenser, A Simple, 208  
 Crystallization, Processes of, 121  
 " of Fats, 237  
 " of Oils, 120  
 " of Salts, 269  
 Crystals, Preparation of, 332  
 " Rings and Brushes of, 236  
 Culture Medium for *Protozoa*, 295  
 Curious Swimming Fern, 270  
 Diatoms, Reproduction of, 88  
 " Mineral Particles, etc., Separation of, 179  
 Diatoms in Stomachs of Oysters, 238  
 Discoloration of Flowers, 148  
 Dissemination of Disease Germs, 208  
 Drinking-Water and the Microscope, 209  
 Earth's Development, The, 122  
 Eggs of Insects as Objects for the Microscope, 148  
 Fig Scale, The, 270  
 Filtering Medium, a New, 178  
 Flour Weevils, 122  
 Fly's Foot, A, 236  
 Foraminifera, 58, 333  
 " Pelagic Distribution of, 122  
 " Recent Research in, 87  
 " Recent Research on, 360  
 Food Supply of Fish, 295  
 Formation of Gold Nuggets, 333  
 Fossil Bacteria, 121  
 Freshwater Mites, British, 86  
 Fungi, Influence of Nutrient Media on the Development of, 295  
 Fungi, Influence of Light on, 88  
 Fungus, A Mystifying, 179  
 Glycerine, 179  
*Haddonia*, 269  
 Haematoxylin and Safranin, Double Staining with, 360  
 Haematoxylin Stain, The, 361  
 Harvest Bug, The, 333  
 Hen Flea, The, 149  
 House-Fly, The, 271  
 Hydra, Distribution of, 87, 120  
 Indian Ink in Microscopy, 360  
 Inter-Relations of Insects and Yeasts, 209  
 Invisible Friends and Foes, Our, 332

## MICROSCOPY—continued.

- Life-History of an Aphid, 148  
 " of the Flea, 148  
 " of Mealy Bugs, 87  
 " of the Water Mites, 122  
 Life Latent in Seeds and Microbes, 295  
 Light, Influence of, on Fungi, 88  
 Lignite, Cutting Sections of, 269  
 Manipulative Hints, 380  
 Marine Diatoms, Reproduction of, 121, 149  
 Marine Microscopic Life, 58  
*Meridium circulare*, 121  
 Microbe of Ambergris, 178  
 Microbes of Disease, 120  
 " of Paris, The, 360  
 " Street, 178  
 Microbiology, 352  
 Micrometer Measuring Apparatus, 333  
 Micro-Objective, A New, 332  
 Micro-Photography, 295  
 Microscope, Ross' Industrial, 269  
 Microscopes, British, Honours for, 238  
 Microscopic Fungi, 87  
 " Worm, A New, 178  
 Microscopic Preparations, 269  
 " Research, 58  
 " Studies, 148, 179, 208  
 Microstereograms, 269  
 Microscopy, Practical, 209  
 Micro-Structure of Alloys, 270  
 Minute Flowering Plant, A, 269  
 Mosquitoes, 149  
 Mounting Aphides, 238  
 " Chara, 88  
 " Foraminifera, 269  
 " Hairs, 179  
 " Medium, 148  
 " Volvox, 236  
 " Wings, 86  
 Mushroom Spores, 120  
 Mycetozoa of Antigua, The, 360  
 Mycology, British, During Sixty Years, 208  
 Mycorrhiza of Roots, 295  
 Myxomycetous Parasite, A, 296  
 Nerves of Mouse's Ear, 179  
 Nitrifying Germs, 209  
*Noctiluca miiaris*, Photogenic Functions of, 361  
 Objectives, How to Test, 121  
 Odontophores of Snails, 236  
 Oolitic Grains, Microscopic Sections of, 296  
 Orange Mite, The, 209  
 Organisms, Photogenic, 361  
 Oysters, Enemies of, 148  
 Ova, Preparation of, for Microscope, 88  
 Parasitic Enemies of the House-Fly, 269  
 Petrological Slides, 57  
 Phosphorescence of the Limans, 295  
 " of Wood, 333  
 Photo-Micrography, 295  
 Photo-Micrography of Opaque Stem Sections, 208  
 Pliocene Diatomaceae, 209  
 Pond Life, 57  
 " Sweep, A New, 57  
 " Gatherings, Preserving, 86  
 Powders Identified by Pollens, 121  
 Protoplasm, Mechanism of, 332  
 Protozoa of Salt Lakes, 208  
 Rabies, Parasite of, 360  
 Readers, To our, 360  
 Refractive Indices of Certain Liquids, 236  
 Roterlian Specie Mongers, 87  
 Safranin Stain, The, 361  
 Sapphire, Microscopic Bubbles in a, 27  
 Scales of Lepidoptera, Taxonomic Value of, 27  
 Sections, Cutting the, 361  
 Section, Mounting the, 361  
 Seeds as Objects, 25  
 Senses of Insects, 96  
 Shepherd's Purse, 58  
 Sponge Spicules, 179  
 Staining Insects' Wings, 57  
 Stains, Methods of making the, 361  
*Stereum hirsutum*, 332  
*Stigolobium*, 219  
 Tissue Bedding, 88  
 Varnish, Dead Black, 236  
*Vaucheria*, Spores of, 58

## MICROSCOPY—continued.

- Volvox, Fruiting-time of, 122  
 Water Mites, Preservation of, 57  
 Yeasts, Action of Light on, 238  
 Mild Winter, The, 254, 272, 299  
 Millport Marine Biological Station, 351  
 Mineral Phosphorescence and X-Rays, 285  
 Mokomokai, or Dried Human Head, 165  
 Moon, The: Has it an Atmosphere? 339  
 Moths, Assembling, 342  
 Museums, Sir John Gorst's Committee's Report on, 16  
 Mycological Society, British, Annual Foray of, in Sherwood Forest, 168  
 NATURAL HISTORY EXHIBITION, 12  
 Natural History in New Forest, 72  
 " History Societies and Technical Institutes, 272  
 Naturalist, A Primitive, 247  
 Naturalists' Directory, The, 137  
 " Young, Chapters for, 140, 167  
 Nature Notes from Ireland, 228  
 Neuration, New Method of Studying, 113  
*Neuropterus*, 131  
 NOTES AND QUERIES.—25, 26, 58, 85, 123, 124, 150, 151, 172, 211, 243, 272, 299, 336, 358  
 Abnormal Cucumber, 123  
 " Oranges, 26  
 " Primrose, 25  
 " Walnut Leaf, 85  
 Albino Sparrow, 172  
 Aquaria in Winter, 299  
 Badger in Sussex, 151  
 Bird-Song in Durham, 25  
 Black Pepper-and-Salt Moths, 243  
 Booth Museum, The, 336  
 Botanical Plates, 211  
 Cinnamon Variety of Blackbird, 123  
*Claytonia perfoliata* Don., 358  
 Cleaning Lenses with Pith, 299  
 Colt's-Foot, 299  
 Derivation of Microlestes, 123  
 Destruction of Bird Life in Tasmania, 358  
 Destruction of Hornets, 243  
 Double Mushroom, 272  
 Early Flowering of Cowparsnip, 299  
 " Elm, 299  
 Earthquake Shock, 172  
 Effect of Adder's Bite, 211  
 Egg, Great Auk, 358  
 Flounders in Fresh Water, 85  
 " 352  
 Foraminifera in London Clay, 25  
 Foster-Parents of Cuckoo, 25  
 Fungoid Pigment, A, 299  
 Habits of Bull-tip Moth, 151  
 " Leaf-Cutting Bees, 124  
 " Owls, 299  
 " Sparrows, 211  
 Harvey, Dr. William, 272  
 Hedgehogs carrying Fruit, 85, 123  
*Helix arbustorum* Sub-Fossil, 150  
 Honeycomb Weathering on Stone, 27  
 Little Owl in Sussex, 243  
 Manganese Deposits, 25, 58  
 Marine Mollusca of North Devon, 85  
 Maternal Instinct of Spider, 151  
 Mollusca in Country Antrim, 58  
 Natter's Bat in Co. Down, 151  
 Newspaper Nat. History, 85, 272, 299  
 Norfolk Plover in Sussex, 336  
 Object in Flint, An, 358  
 October in Cornwall, 172  
 Orchidaceae in Surrey, 25  
 Original Research, 150  
*Paludetrina ulvae*, Varieties, 150  
 Phenological Notes, 211  
 Phytology in Aberdeenshire, 123  
 Popular Collecting-Grounds, 211  
 Preservation of Rare British Animals, 123  
 Primitive Trepanning, 243  
 Rabbit Hunted by a Cat, 150  
 Ragged-Kobbin in Winter, 272  
 Rare Fungl near Croydon, 211  
 Ringing Mounts, 58  
 "Scientist's" Natural History, 85  
*Sirex juvenis*, 123  
 Skua, The Great, in Sussex, 358  
 Slugs, 123, 151  
 Snails in Roadside Hedger, 336  
*Spirula peronis* in Devonshire, 150

## NOTES AND QUERIES—continued.

- Spring Arrivals, 358  
 Swiney Lectures on Geology, 151  
*Tellina radiata* in Ireland, 150  
 Traveling Illustrated Lectures, 123  
 Varieties of British Butterflies, 25, 206  
 Varying Distance of Sun, 273, 299  
 Winter Flowering of Plants, 299  
 Yucca Flowering in Winter 272  
 Notes of a Home Naturalist, 18, 104  
 " on Plant Life, 292  
 OBITUARY.  
 Abercromby, Hon. R., 206  
 Allen, Dr. Harrison, 293  
 Bartlett, A. D., 1  
 Béchervaise, A. H., 298  
 Bessemer, Sir Henry, 329  
 Chamberlain, Humphrey Barker, 51  
 Clark, Alvan G., 83  
 Cope, E. D., 19  
 Denton, J. M., 19  
 Dickson, Oscar, 31  
 Doggson, Chas. L., 266  
 Dunning, J. W., 210  
 Geddes, J. Gamble, 19  
 Hardenham, Dr. R. P. H., 206  
 Hart, Ernest, 266  
 Hicks, Dr. John Braxton, 145  
 Horn, Dr. George H., 293  
 Houghton, Dr. Samuel, 206  
 Kammernann, Arthur, 298  
 Kirk, Professor, 354  
 Layens, G. de, 261  
 Leuckart, Rudolf, 354  
 Lindemann, Dr. E., 298  
 Marco, Jules, 354  
 Marks, Henry Stacy, 266  
 Marquand, Leopold, 240  
 Marth, Albert, 128  
 Matthews, Rev. Andrew, 176  
 Mojsvar, Prof. von, 176  
 Muller, Daniel, 84  
 Noble, Dr. A., 118  
 Parker, Thos. J., 266  
 Ramsay-Gibson-Maitland, Sir James, 206  
 Rogers, Prof. W. A., 330  
 Schroeder, Prof. W. von, 298  
 Stone, Edward James, 19  
 Stumpe, Dr. Oscar, 298  
 Tschernberg, Prof. E. L., 268  
 Watson, Capt. E. Y., 206  
 Winnecke, F. A. T., 267  
 Obsidian, Microscopic Crystals in, 180  
 " Red, Thin Section of, 180  
 Odontophores of Mollusca, 6  
 Orcadian Rambles, 204, 224, 261, 286, 315, 349  
 PATRON OF SCIENCE, 31  
*Phacus longicaudus*, 309  
 " *pleuronectes*, 345  
 " *pyrum*, 345  
 " *triqueter*, 309  
 Photography, Orthochromatic, 301  
 Microscope, 49  
 Physical and Mechanical Disinfection, 14  
 Plants of Killarney, 108  
 Plants, Life-Histories of, 15, 38, 80, 105  
*Plectopylis*, 284  
*Polia excavata*, 9  
 Prehistoric Man, Remains of, near Mentone, 173  
 Preservation of Rare British Animals, 63  
 RARE ANIMALS IN LONDON, 142  
 Rare Plants in Lincolnshire, 59  
 Repairing an Electric Cable, 95  
 Rocks of the Isle of Man, 199, 219, 259  
 Royal Institution Lectures, 232, 317  
 " Society, New Fellows of, 25  
 " Society's Soirée, 12, 56  
 Royle's Balsam, 318  
 SATURN'S RING SYSTEM, 177  
 SCIENCE ABROAD, 22, 52, 89, 117, 146, 182, 211, 241, 274, 302, 335, 362  
 Acidity of Natural Sciences, Phil., 22, 52, 89, 362  
 Album de Natur, 302  
 American Journal of Science, 146, 182  
 Annales de Sciences Naturelles, 22, 52

SCIENCE ABROAD—*continued.*

- Annali del Museo Civico di Storia Naturale di Genova, 22  
 Bollettino dei Musei di Zoologia ed Anatomia Comparata, 302  
 Bulletin de la Société Philomathique de Paris, 89  
 Bulletin de la Société Zoologique de France, 89, 146, 302, 362  
 Canadian Entomologist, 52  
 Catalogue of a Collection of Birds of Somaliland, 117  
 Climate of the Yukon Basin, 335  
 Coastal and Plain Flora of Yucatan, 117  
 Cosmos, 146, 182, 241, 302  
 Feuilles des Jeunes Naturalistes, 22, 52, 117, 146, 241, 274, 302, 362  
 Intermediare, L', des Biologistes, 241  
 Karpinski, Prof., 22  
 Moniteur Scientifique, Le, 241  
 Nature, La, 146, 182, 213, 302  
 Osprey, The, 89  
 Portland Society of Natural History, 117  
 Proceedings of the American Philosophical Society, 146  
 Revue Linnéenne, 89  
 Revue Scientifique, 182  
 Természetráji Füzetek, 117, 241, 362  
 Transactions Acad. of Science, St. Louis, 241  
 Victorian Naturalist, 52, 274

SCIENCE-GOSSIP—*continued.*

- 206, 240, 268, 298, 330, 354  
 Alga, A New Irish, 118  
 André, M., His Ballooning Expedition, 24, 84  
 Antarctic Exploration, 84, 118  
 Bacillus of the Indian Plague, 84  
 Balloon, Experimental Ascents, 354  
 Biograph, The, 206  
 Bird Protection, America, 354  
 British Association Meeting at Toronto, 118  
 British Flora, A New, 354  
 Burial-place of the Chuds, Discovery of a, 176  
 Butterfly, Marbled White, Var. of, 206  
 Canada, Nickel Ore in, 24  
 Coccides and Arthropoda, 24  
 Cormorants at Ullswater, 240  
 Early Man in Egypt, 47  
 Earthquake in Bengal, 56  
 " of Assam, 354  
 Entomological Society for Quebec, 24  
 Flora of Russia, 24  
 Flying-foxes, Edible, 24  
 Flying-fish, 79  
 Glaciology, Norfolk, 169  
*Helix arbustorum* in Ireland, 84  
 Hens' Eggs, Specific Weight of, 330

SCIENCE-GOSSIP—*continued.*

- Hepaticae, Irish, 24  
 Hooker, Sir Joseph, and the Flora of British India, 145  
 Hybrids, 24  
 International Journal Microscopy, discontinued, 176  
 Jubilee Congratulations by Men of Science, 84  
 Jubilee Honours to Men of Science, 56  
 Kangaroos in Britain, 71  
 King Fish, Capture of, 118  
*Lampris luna*, 118  
 Marsh-marigold, Abnormal, 12  
 Meteor, A Remarkable, 330  
 Mirage at Wady Halfa, 118  
 Moa, Skeleton of, 240  
 Mount St. Elias, Canada, Origin of, 145  
 Natural History and Wicken Fen, 113  
 Nomenclature, 2, 277, 353  
 Non-marine Molluscs of Essex, 145  
 Ornamentation on Prehistoric Pottery, 206  
 Orthoptera, North American, 145  
 Physical Laboratory, A National, 118  
 Royal Society Honours, 206  
 Rockall visited, 240  
 Russian Thistle, Spread of, in North America, 176  
*Salsola kali*, 176  
 Science Examination, Intermediate, Protest against the New Regulations, 240  
 Scientific Degrees, Bogus, 145  
 Scientific Societies, Union of South Eastern, 40  
 Slime Fungi, 163  
 Stork, White, in Sussex, 142  
 Strata of the Quaternary Period in Algiers, Discovery of Remains in, 24  
*Streblomena minimum*, 118  
 Telegraphy without Wires, 56, 145  
 Underground Zoology, 240  
 Vertebrate Fauna of Shropshire, 321  
 Water Divining, 56  
 West Ham Museum, 240  
 Wettest Winter on Record, 24  
 Wild Horse in Kildare, Discovery of Remains of, 268  
 Science and the Education Grant, 46  
 " in Some Magazines, 90, 114, 144, 171  
 Scientific Literature, Serial Popular, 203
- SCIENTIFIC SOCIETIES, Metropolitan, 156, 186, 216, 246, 276, 306, 338, 365
- SCIENTIFIC SOCIETIES, Notices of, 30, 62, 94, 126, 186, 205, 215, 245, 305, 337, 365

- Shells, Nomenclature of, 353  
 " Röntgen Rays Pictures of, 16  
 Studies, Some Neglected, 105  
*Succinea*, 45  
 Strange Insect, A, 136

- TACHEA, TWO SPECIES OF, 133  
 Tame Blackbird, 47  
 Te Pehi Kupo: An Example of Tattooing, 164  
 Thanet Sands, 43  
 Through the Marshes, 107  
*Trachelomonas euchlora*, 346  
 " *hispidia*, 346  
 " *volvocina*, 346

- TRANSACTIONS, 26, 60, 90, 124, 153, 183, 213, 238, 241, 243, 274, 303, 336, 342, 336  
 Cambridge Entomological and Natural History Society, 29, 184, 214  
 City of London Entomological and Natural History Society, 28, 91, 124, 184, 214, 244, 304, 363  
 Conchological Society, 124  
 Cork Naturalists' Society, 24  
 Greenock Natural History Society, 155, 304, 364  
 Hertfordshire Natural History Society, 245  
 Hull Naturalists at Spurn, 124  
 Hull Scientific and Field Naturalists' Club, 29, 61, 84, 93, 185, 364  
 Lambeth Field Club, 172  
 North London Natural History Society, 27, 60, 91, 154, 184, 214, 274, 304, 336  
 Nottingham Naturalists' Society, 215  
 Preston Natural History Society, 240  
 Quekett Microscopical Club, 270  
 Royal Institution, 232, 303, 317  
 Royal Meteorological Society, 26, 60, 213, 244, 274, 303, 336, 364  
 Selborne Field Club, 26  
 South London Entomological and Natural History Society, 30, 60, 90, 153, 183, 214, 243, 303, 363  
 Tunbridge Wells Society, 205  
 Woolhope Naturalists' Field Club, 153

- VARIEGATED LEAVES, CAUSE OF, 293  
 Vegetable Nature of Diatoms, 65  
 Virginia Colony of *Helix nemoralis*, 67, 118  
*Vitrina pellucida*, 9

- WATER-MITES, 187  
 Wild Traits in Tame Animals, 247  
 Wookey Hole Cave, 217

- ZOOLOGICAL NOMENCLATURE 277



# SCIENCE-GOSSIP.

## ABRAHAM DEE BARTLETT.

MR. A. D. BARTLETT, late Superintendent of the Zoological Society's Gardens, Regent's Park, was born in London on October 27th, 1812. He received a simple education in London, and at a very early age evinced a great delight in all matters connected with natural history. Mr. Bartlett commenced business as a taxidermist in a house in Little Russell Street. In those early days of his career scientific men and collectors of rare birds, and especially birds' eggs, made his house a resort, and the reputation of his extraordinary art in taxidermy became so widely spread that he was obliged to move into larger premises. There are few, if any, of those early zoologists and collectors left to remember that he removed his business to a large house in Great College Street, Camden Town. In that place his circle of admirers increased and his first connection with the Zoological Society of London commenced. His first communication to that society occurred in 1839, and from that time he worked not only for the society, but for nearly all the scientific men and established museums, including Her Majesty the Queen and H. R. H. Prince Consort. It was in that house he prepared all his exhibits for the 1851 Exhibition, and among them were, by permission, several of the Queen's specimens, which are believed to be now at Windsor Castle. After the close of the Exhibition of 1851, the Crystal Palace Company started, and not being able to find a more proficient naturalist to take charge of the collection of living animals which was established there, he received the appointment. This collection was placed in the south transept, and afterwards were added the aviaries, etc., in the north transept. About this time Mr. Bartlett was occupied with

attending to endless other matters of a similar character in various places. After working laboriously for the Crystal Palace Company up to 1859, and at the death of Mr. John Thompson, then superintendent of the Zoological Gardens, Dr. P. L. Sclater, the then newly-appointed secretary, in course of conversation with Mr. Henry Walter of *The Times*, remarked that they were seeking a new man for the post. Mr. Walter at once recommended Mr. Bartlett, and he was immediately communicated with, and accepted the post, which he has held ever since up to the time of his death. It would be difficult, and beyond the limits of this notice, to give a detailed account of the vast amount of work carried out by the Zoological Society on their menagerie during the years from 1859 to the present day. We are, however, given to understand these particulars will be compiled before long in a collected and chronological form.

Mr. Bartlett was awarded the medal for taxidermy at the 1851 Exhibition, the bronze and silver medals of the Zoological Society, and a very long series of the highest testimonials from different societies and exhibitions. He also received the bronze medal, conjointly with his eldest son Edward, at the 1872 Exhibition, and also testimonials, with his sons Edward and Clarence, at the Colonial Exhibition. The latter son has for some time past assisted his father in the onerous but successful duty of caring for the welfare of the very numerous and valuable denizens of the finest zoological gardens in the world.

During his life in the Zoological Gardens, Mr. A. D. Bartlett devoted his whole energy with great success to the study of captive animal life. All those who knew him can testify to



THE LATE MR. A. D. BARTLETT.

*From a photograph by F. C. Brook, Walton-on-Naze.*

his being a man of vast resource and quick perception, and in many most difficult cases he was always ready to help those around him out of what frequently appeared to be an almost hopeless position. Naturally of a most amiable temperament, Mr. Bartlett was ever kind to all classes of society with whom he came in contact, but at the same time he was of a retiring nature. Few men were better known or respected than

Mr. Bartlett, and his long association with the Zoo made him a favourite with succeeding generations of delighted visitors, to whom he would often, in spite of his many duties, find time to tell quaint facts and anecdotes about his animals, which long lived in the memories of the visitors. He died in his eighty-fifth year, on May 7th, after a long and painful illness, and rests in the family grave in Highgate cemetery.

## THE CONFUSION IN NOMENCLATURE.

BY W. H. NUNNEY.

THE publication in the recent pages of SCIENCE-GOSSIP of notes on this important subject, as well as of an epitome of the code of zoological nomenclature compiled by the German Zoological Society, which appeared in "Nature" of the 5th March, 1896, and the issue, in November last, of Lord Walsingham's and Mr. Hartley Durrant's "Merton Rules," will have attracted the attention of naturalists. A few additional thoughts on this subject, with a view to rendering the confusion somewhat less, may not be ill-timed.

These sets of rules necessarily differ, but in the main may be said to be based on the Stricklandian code which has done such excellent service, the German code being somewhat the more concise. It is, however, hardly requisite to publish the sets side by side.

Both the "Merton" and the German rules are restricted in their use to purely zoological nomenclature, whilst the Stricklandian deals also with botany. The latter assumes that a name should be utilised once only in any department, and that it shall not occur in both botany and zoology. With this I practically agree. Unfortunately, however, the dual use is in vogue. It may, nevertheless, be said that under the existing and probably increased future conditions of forced specialism it must be very evident that the average zoologist, for instance, has quite enough to do to gather and retain knowledge relative to his own subject, without being able, if desirous, of giving sufficient attention to botanical matters to enable him to steer clear of clashing in that connection. Under the Stricklandian code and the law of priority, much, in my opinion, needless labour is forced upon the describer of species and the creator of fresh divisions. Few zoologists are acquainted with zoological and botanical nomenclature; the botanists' wish to retain a name familiar to them must also be considered. The advancement of science is of course retarded by the ensuing altercation as to the questions of familiar use, priority, etc. I myself fail to see why

the contemporaneous use of one name in two such great divisions of nature should not be allowed; as, for instance, *Corydalis*, occurring in both entomology and botany, as a matter of fact could not lead to confusion. Granted the same root-word, a varying termination would surmount the difficulty.

It has indeed occurred to me that perhaps the very best thing that could happen would be the introduction of a kind of scientific Volapük, or arbitrary means of manipulating the terminations of all the words of the greater divisions of each class, so that by first of all having committed to memory the whole number of terminations, one could, upon becoming acquainted with a word new to one's vocabulary, tell by its final consonant or vowel to what main and (if the principle were carried far enough) even perhaps to what subgroup the corresponding species belonged. Such terminations might at first be looked upon as somewhat uncouth, but would, I am inclined to think, prove a vast advance upon the present loose system of like endings in many groups of all grades, as formerly used by lepidopterists.

In considering zoology alone, and in the department of entomology, I would group the generic names somewhat as follows: coleoptera, all names ending in the letter "a," thus, *Emusa hirtus*, *Staphylinusa casar*; in neuroptera, the vowel "e," *Sialise ferruginea*, and so forth. This would hardly, I think, clash with rule 4 of the German code, to the effect that names differing only orthographically be considered identical, and I publish the idea for what it is worth. Under this rule, and considering odonata, the use of the words *Æschna* and *Æshna*, for instance (see Mr. W. F. Kirby's "Catalogue of Odonata"), must be discounted, and I think rightly, especially as the first of these names should strictly, with regard to the law of priority and the theory of types, be deleted.

The law of priority, the main principle of all the codes quoted, is, as has often been remarked, by no means an unmixed blessing, though by its aid

alone some naturalists have contended will the existing confusion be eventually counteracted and nomenclature established on unalterable principles. Until the arrival of this golden age, however, must we still hug the mortification of having frequently to unlearn what has been acquired by a no means easy process, and destroy the harmony of association of well-established names with the species to which they refer? Much time usually elapses before a name freshly utilised serves to call to mind its peculiar genus or species, and we have no guarantee that it will not be soon again upset in favour of some prior name. The most advisable course to adopt, so far as I am able to judge, where an organism has been named and the name given has by continued use caused its species to be readily called to mind, would be to waive entirely the law of priority and to follow the usage. The main requirements of a system of nomenclature having been met, all other names appertaining to the same species to be ranked as synonyms. With regard to odonata alone, there are many sufficiently definite and well-established names that under a strict application of the law of priority must need be sunk in favour of other designations far less expressive of specific traits; because they have been rescued from an obscurity to which they would be well again consigned. Such a case is presented by the use of *Symptetrum* (Newman), instead of the equally expressive and far better known *Diplax* of Charpentier, the former having been alluded to in few terms in the "Entomological Magazine." The argument for the use of *Symptetrum* is that a type was assigned to it, whilst *Diplax* was instituted without, and with insufficient characterization.

It is here, however, surely better on many grounds to follow usage rather than priority. Thus in this instance, *Diplax* has many derivative names—*Symptetrum* none, and naturalists can ill afford to neglect such aids to the study of affinities as are to be found in the indications to their authors' views of relativity as are furnished by the use of derived names. If, under the laws of priority, *Symptetrum* is to take the place of *Diplax*, these indications are at once lost sight of, and nothing had in exchange but needless obscurity. This point seems to have been entirely lost sight of in the melee of nomenclators. I argue, if Newman's ground-generic name *Symptetrum* be retained, that such derived names as *Thecadiplax* should be altered to *Thecasymptetrum*; or, what is far more simple and regular on account of the number of derivatives, the holding to *Diplax* as the general typical generic name. *Gomphus* is another instance; in this case there are no less than twenty-eight derivatives. Mr Kirby argued in the Introduction to his "Catalogue," the change of this name to *Æshna*, its co-equal thus

*Crenigomphus* should then be *Creniæshna*, and so forth. Fabricius's name is, however, inadmissible, inasmuch as the spelling is erroneous and conflicts with *Æshna*, the name of a totally different group, which should, strictly on that account, be renamed. Fabricius, however, did not indicate a special type for *Æshna*, whilst Leach, in leaving this latter name unrecognised, indicated the species *vulgatissimus* as the type of his genus *Gomphus*. This name should therefore stand. It occurs also in botany, (in fungology), but the prior use is in odonata. Yet another instance from the odonata. There are many derivatives of the name *Agriion*, this name meaning the smaller species termed by Mr. Kirby, *Cænagriion*. He considers Latreille to have assigned the species termed by the French, "Demoiselles," as types of this genus. This Latreille, however, does not especially do, and the prolonged usage of the name in connection with such species as *puella* should be sufficient to allow of that conception remaining intact, otherwise the derivatives should be altered to *Megapocœnagriion*, *Anomalocœnagriion* and such-like ineuphonious and anomalous appellatives.

Numerous instances in other departments will doubtless occur to the reader. This then is in itself perhaps the weightiest argument for a continued use of well-established titles. Granting that scientific nomenclature commenced with Linné, until lately systematists could not agree as to which edition, the tenth or twelfth, of his "Systema Naturæ" should be accepted as a basis of priority. The whole question as it now stands is a splendid farce. Dr. Pascoe has well remarked that the law of priority, if carried out in its entirety, even with regard to insects, would make confusion worse confounded. It is certain we cannot safely carry the law further back than Linné, for who can say what were the *Cossus* and *Buprestis* of the ancients? Without doubt, the *Cossus* of Græco-Roman times ranked with the coleoptera and not with lepidoptera, as at present accepted.

In connection with generic titles, it is a great pity that names of like derivation cannot be restricted to one group of animals. As matters now stand we have *Lestes* in odonata, and *Microlestes* in mammalia. The first title has many derivatives in odonate genera; I think none elsewhere, with the exception mentioned; *Microlestes* again means "small *Lestes*," and by "the eternal fitness of things" this latter has been tacked on to a mammal many thousand times larger than the odonate. The German rules tend to eliminate such undesirable usage.

Another point of great moment is with regard to the significance of names. Specific or generic, they should be expressive of some character possessed by the species. Towards this end it would be as well for future nomenclators to

entirely discontinue the naming of species after persons, however eminent in their own branch of study. I am afraid a person's name is frequently given as much out of indolence in searching out a fitting title, as the desire to honour a specialist. It is evident that scientific advancement is best served by purely descriptive names, though the personal title-giving is somewhat less reprehensible for botanical purposes, bearing in mind the horticultural aspect; in that connection the malpractice is very frequent.

The theory of priority based on types is at first sight good; but it is, I think, extremely questionable whether in the case of the resuscitation of a lost-sight-of type, in conjunction with the law of priority, it is not better to allow usage to prevail.

Where no type has been definitely assigned by the erector of a genus containing in its primitive condition a heterogeneous collection of species, I hold a succeeding author well within his rights when creating new genera from the old material, in making not only the first species on the list the type of the old genus, but any of the contained

species most agreeing with the old generic characters. The first-named method is, however, usual. Thus, in *odonata*, I consider Leach to have definitely fixed several important types by the creation of his genera *Gomphus* and *Calopteryx*, rather than that, for instance, the type of the latter were fixed by Latreille's usage of Linnean material. The German code favours my view, which, of course, in the main, brings us back to the desirability for keeping to the use of established names and popular types rather than in all cases the author's own.

The wish of all naturalists must be to see the various open questions of nomenclature finally settled, for both present and future satisfaction and future advancement, and it is to be hoped that this will soon be done through the agency of an International Congress of interested men of science. Shiftiness of nomenclature is one of the greatest stumbling-blocks in the way of the study of species and the encouragement of students.

Stoke Newington; May 15th, 1897.

## THE COLOUR OF BLOOD.

BY FELIX OSWALD, B.A. LOND.

"BLOOD-RED" is so familiar an adjective of colour, as to readily convey the impression that the blood of all animals is red. Such, however, is far from being the case, for although the possession of red blood is a characteristic common to all vertebrates<sup>(1)</sup>; yet when we come to examine the invertebrates, which are far more numerous both in species and individuals, we find that blood of a red colour is a relatively rare occurrence. In the majority of cases it is colourless; but it may be even green, blue, or yellow.

It has often been a subject for speculation why the life-fluid of higher animals should have so vivid a hue, seeing that it is normally concealed from view, and seldom or never plays any part in determining the surface-colouration, excepting in a blush. It is only a partial explanation to say that the redness is due to hæmoglobin, and that it is an inherent physical characteristic of this body. The reason for the red colour is quite as difficult to explain as to account for the distinguishing colours of gold, silver, or copper. It is no exaggeration to say that hæmoglobin is the most important substance in the complex combination called blood, for it is hæmoglobin which absorbs oxygen from air or aerated water, conveying it to all tissues in need of that vital gas, receiving carbon

dioxide in return, and finally giving up the excess of this waste-product of combustion to the surrounding medium. Hæmoglobin can be artificially separated from blood to form crystals, differing in shape according to the animal. Usually, as in man, they take the form of prismatic needles or rhombic plates. It can furthermore be resolved into hæmatin, a dark-brown amorphous powder, and an albuminous substance called globulin. Under the spectroscope it exhibits a very characteristic absorption-spectrum<sup>(2)</sup>, by means of which Lankester and others have been able with absolute certainty to demonstrate its presence in the blood of certain invertebrates.

The hæmoglobin in the blood of vertebrates is contained exclusively in little circular discs<sup>(3)</sup>, the red corpuscles. In the few instances in which it occurs in invertebrate animals, it is generally diffused in the plasma, e.g. in the blood of the earthworm and many other *Chætopod* worms, in some leeches (the *Gnathobdellidæ*), in some Nemertine worms (e.g. *Polia*), in the freshwater mollusc *Planorbis*, in a few small crustaceans (*Cheirocephalus* and the water-flea *Daphnia*) and in the so-called bloodworm (the larva of the midge, *Chironomus*). Less frequently it is

(1) There appear to be only two exceptions to this rule, viz., the lancelet (*Amphioxus*), which is the lowest vertebrate, and the transparent little fish *Leptocephalus*, now regarded as the larval stage of the eel.

(2) It is interesting to note, as Prof. Church points out, that hæmoglobin possesses the same conspicuous absorption-band in the ultra-violet as chlorophyll, although, of course, the rest of the spectrum is very different.

(3) Elliptical in fishes, amphibians, reptiles, birds and in the camel family. In the lampreys, however, the red corpuscles are circular.

found concentrated in corpuscles, e.g. in the bivalve molluscs, *Solen legumen* and *Arca noæ*, in a few Chaetopod worms (e.g. the Polychæta *Glycera* and *Capitella*), in some Gephyrean worms (*Phoronis*, *Thalassema*, *Hemingia*), in some Nemertine worms (e.g. *Cerebratulus*), and in a few Echinoderms (*Thyonella*, a sea-cucumber, and *Ophiactis*, a brittle starfish). These examples occur sporadically among such widely-separated groups of animals that hæmoglobin must evidently have been independently acquired several times in the animal kingdom. It is clear that the possession of it does not in itself indicate any relationship.

Arterial blood is scarlet owing to the hæmoglobin containing a rich supply of oxygen; on the other hand, the dark purple colour of venous blood is due to an excess of carbon dioxide. Both gases, however, are present in arterial as well as in venous blood; indeed, the former actually contains more carbon dioxide than oxygen. The difference in colour, therefore, is merely a question of varying proportion, for an artificial solution of hæmoglobin changes colour from purple to scarlet when a current of oxygen is passed into it. It is indeed probable that the oxygen enters into a state of unstable chemical combination with the hæmoglobin, and that the red corpuscle does not merely hold it as a sponge. In this way the presence of hæmoglobin is an absolute necessity for the more remote internal parts of the body to receive a due supply of the vivifying oxygen and to get rid of the waste carbon dioxide. Indeed, it is doubtful whether vertebrates could have reached their great size and dominant position in the world without the possession of hæmoglobin in its valuable capacity for storing up oxygen. Hæmoglobin, however, is not confined to blood, but is contained in the voluntary muscles of the higher vertebrates (hence the red colour of raw flesh) as well as in the tissue of the heart. Among fishes, however, it is entirely absent from the muscular tissue of the body, excepting in the fin muscles of the graceful little sea-horse (*Hippocampus*). Among invertebrates it is found in the muscles of the pharynx of a few molluscs (*Chiton*, *Patella*, *Littorina*, *Paludina*, *Lymnaeus* and *Aphysia*), but, strange to say, not in the blood of these creatures. In the Chaetopod worm, the sea-mouse (*Aphrodite*), it is even restricted to the nerve centres.

In reviewing the habits of those invertebrates which possess this valuable coloured substance, we are able to infer that either (1) they show increased activity compared to their nearest relations, as in the case of the Neapolitan razor-shell (*Solen legumen*), or (2) they live under circumstances in which oxygen is not easily obtained, as in the case of the bloodworm in the mud of stagnant pools, etc.; this is probably the main cause, and the power of being able to store up oxygen, whether in blood

muscle, or nerve, must be a valuable aid in such adverse conditions; or (3) there may be a combination of these reasons, as in the leeches, which inhabit miasmatic localities and yet show great activity, leaping upon any unfortunate man or animal invading their marshes. In the case of the bloodworm, Professor Miall has shown that it could live as long as five days in water that had been deprived of its oxygen by boiling. The view that hæmoglobin has been primarily acquired merely as an expedient in conditions unfavourable to easy respiration, is supported by the fact that the insect *Chironomus* possesses it only in its larval (bloodworm) stage, but when it reaches its final and winged state, its blood is colourless. The disappearance of hæmoglobin in the blood of the perfect insect is indeed a highly remarkable fact; yet it is not surprising when, we consider how thoroughly air is distributed to every tissue in an insect's body through the air-tubes or tracheæ. The excessively delicate ramifications of these tracheæ extend into every muscle and even penetrate between the cells of the eye and of the nerve centres; hence, since every part of the body has direct access to the oxygen of the air, there is no need for this gas to be conveyed by the blood; consequently the circulatory system in insects is very imperfectly developed, and the blood is colourless.

Hæmoglobin does not, however, stand alone in the animal kingdom in its function of storing up oxygen. In the blood of certain tube-forming worms (*Sabellidæ* and *Serpulinæ*) a greenish substance, chlorocruorin, occurs which has similar powers of absorbing oxygen and yielding it up to all parts of the body in need of it. It is, therefore, within the range of possibility, that if the ancestor of the vertebrates had developed chlorocruorin in its blood in preference to hæmoglobin, our blood might be green, instead of red, and our admiration aroused by a verdant instead of a pink complexion.

49, Blomfield Road, Maida Hill, London, W.;  
April, 1897.

YERKES GREAT LENS.—After having taken about five years to make and grind, the great lens has been mounted and brought into use at the Yerkes Observatory, Chicago. This enormous lens has a surface diameter of forty-one and a-half inches, and weighs no less than five hundred and fifteen pounds. It was first used on the night of May 21st, in the exploration of Jupiter. Much is expected from the astronomers who have control of this splendid instrument.

PHOTOGRAPHIC MATERIAL.—We have received from Messrs. George Houghton and Son, of 89, High Holborn, London, their very comprehensive catalogue of photographic cameras, and every other imaginable article used in the practice of photography. It forms a large and bulky volume, which cannot fail to be useful to both photographers and dealers in their material.

## THE ODONTOPHORES OF MOLLUSCA.

By E. W. WAKE BOWELL.

IN these days, when the microscope has become part of the necessary outfit of the naturalist, it is somewhat remarkable how little attention is given to the odontophores of our native Mollusca. Most of the current manuals of British shell-lore inform us that "these beautiful objects" may be extracted by means of a spirit-lamp, test-tube and caustic potash. Statistics have also been published in such books explaining that certain species have so many rows of so many teeth each, totalling up to so many thousand teeth. Learned professors have concocted Greek names for various forms of odontophore only less remarkable than the objects themselves. It seems to be generally understood that odontophores are worthy of study; and yet how seldom do we come across anybody who knows anything about them. We are told that it is a question of "internal anatomy"; but if it be so, the difficulties attending the study are not prohibitive, and it might well be taken up by naturalists, who would pause before dogmatising concerning the intestinal convolutions of a slug. It is in the hope of interesting some of the less advanced students of malacology that the following notes are written.

The majority of workers at this subject, so far as I can gather, do not stain their preparations; and they mount, not in balsam, but in glycerine jelly. I think there are good reasons for departing from their practice. An unstained preparation may be intelligible in the case of the larger species, but when we come to such forms as *Conulus* or the *Vertigines*, very little can be made out, even if the form of the "teeth" is previously known to the investigator. I find that all species are very much better for a stain. One cannot expect to get a sharp definition of the teeth (by staining) at the middle and front of the odontophore, but one can often get preparations showing with wonderful distinctness the recently-formed ones at the extreme back of the organ. It is just these teeth which are worth studying. Those which are in actual use generally get rubbed down very soon, and show a blunt apex; such have frequently been figured as the normal form of the tooth. It is practically convenient that these last-formed teeth should be the subject of our quest, since that part of the membrane is much more easily extended to advantage on the slide.

My process is briefly as follows: (1) in the case of the larger species the radula sac, with its muscles, is dissected out—generally a very easy operation. The smaller snails are, if possible, separated from their shells. The portion of the

animal thus obtained is boiled up with a few drops of liquor potassæ in a watch-glass. Some care is needed in this operation, and it is well to do it as slowly as possible. A test-tube is hardly to be recommended, because of the great probability of violent projection of potash and contents; also it is exceedingly difficult to find a small radula in a test-tube. The softer parts will be destroyed by the caustic alkali, leaving the desired radula and the "jaws" or maxilla. (2) These are fished out of the watch-glass and washed in water, the vessel in which this is done being dependent on the size of the objects. Next the radula is separated from the maxilla, which may be dehydrated and cleared for a second preparation. (3) I then stain on a clean slide with Ehrlich's hæmatoxylin, not dilute. The time taken in staining varies from three to ten minutes, according to the character of the radula; but any over-staining can easily be corrected by a momentary sojourn in alcohol (or water) just faintly acidulated with hydrochloric acid. This must, however, be done after the blue colour of the hæmatoxylin has been brought out by washing in tap-water. One can then see whether the blue stain is too deep. (4) It may be that the points of the teeth, as well as the outlines of the basal-plates, are clearly enough indicated in the specimen as it stands; but this is not generally the case, so we add a second stain which will bring out these important details. The very best medium that I have come across is a saturated aqueous solution of ordinary eosin (1). I have tried a great many other coal-tar colours, but none is as good as the eosin, which, moreover, stains very quickly (five to ten minutes), and is not removed *in toto* by subsequent operations. I may as well add that all preparations of carmine that I have tried are absolutely useless for the purpose (2). The hæmatoxylin staining is not in all cases essential, but it generally very greatly improves the effect even when it does not stain the points of the teeth. It has a way of slightly staining the edges of structures which renders it very useful, especially when followed by eosin, which, so to speak, does the filling up. A *Testacella* radula very slightly stained with hæmatoxylin is a great advance on an unstained one, though there is no difficulty in this case in seeing the teeth with the naked eye. (5) The next process is dehydration with alcohol, followed by clearing with oil of ceda

(1) Mine was obtained, through a chemist, from Messrs. Hearon, Squire and Francis. The hæmatoxylin is best from Grüber.

(2) Mr. A. E. Boycott states that one sometimes gets interesting and curious results with picro-carmine.

Aniline oil may be used, and in this case it is not necessary to dehydrate further than with rectified spirit. The eosin is not entirely removed unless one leaves the aniline on for a very long time; two minutes is generally quite enough. Aniline has the disadvantage of eventually asserting its presence by a rather unpleasant yellow colour in the resulting preparation. This will be of small consequence if the radula is thin and consequently there is little of the

object in using a great deal of Canada-balsam, the less the better, in reason. Do not forget to label.

This process may seem tedious, but the results make it worth doing. It occupies from first to last about twenty minutes, and several specimens may be made concurrently. I have tried with some success a single stain made from violet graph-ink, a substance whose exact composition it may not be safe (scientifically) to state with more exactitude. This is quite useless for certain

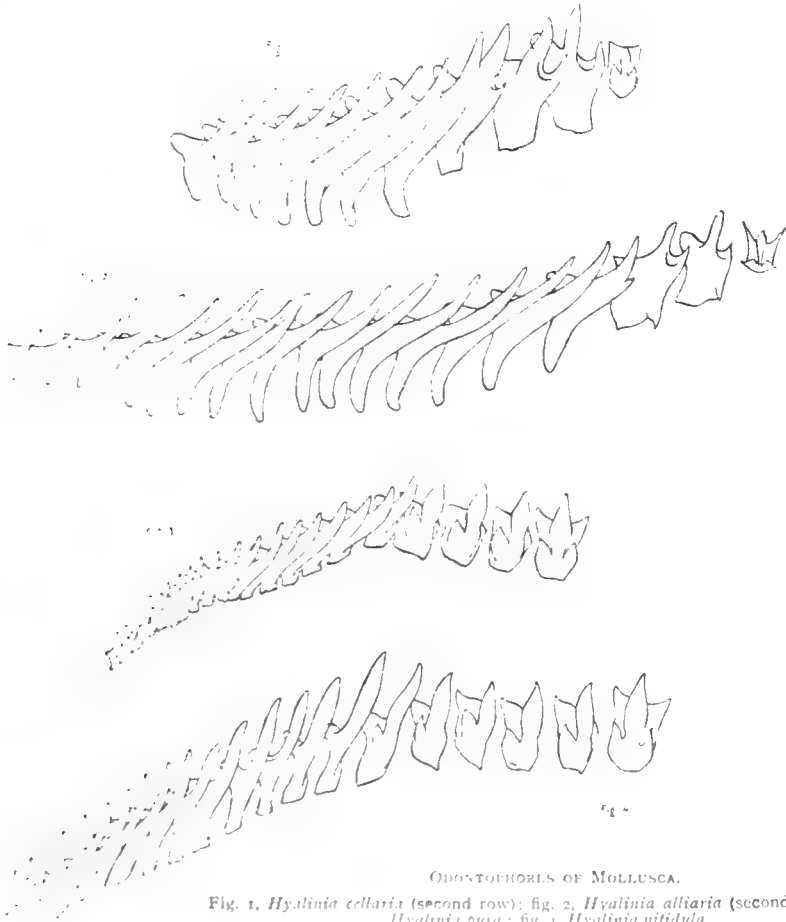

## ODONTOPHORES OF MOLLUSCA.

Fig. 1, *Hyalinia cellaria* (second row); fig. 2, *Hyalinia allitaria* (second row); fig. 3, *Hyalinia puca*; fig. 4, *Hyalinia nitidula*.

mounting medium used, but for the larger objects the cedar-oil process is to be recommended. Oil of cedar does not attack eosin. (6) Finally, having taken care that there are no bubbles in the preparation, and having arranged the end of the radula in its permanent position, dry off as much of the clearing agent as possible with cigarette paper. With care one may flatten out the radula a little with the paper. Put a small drop of Canada-balsam (preferably in xylol) on the object, and gently let down the cover-glass. There is no

species, though it gives good results in others. Its permanence may also be suspected. If one is in a great hurry, and does not want a preparation that will last, one cannot do better than with methylene blue. Methyl green is also very good, and so is safranin, occasionally. Another fairly good but uncertain stain is Nicholson's blue. I have preparations (in balsam) done with this reagent which have lasted perfectly well for eight months, and show no signs of fading; but it is a rough-and-ready method. The colour in methyl

green preparations of the same date has disappeared.

The accompanying figures are designed to illustrate the genus *Hyalinia* as met with in this country, together with a few of its closer allies. I may mention that I shall be glad of living specimens of other species, especially those of this group, and any proximate Continental forms which may be figured in a subsequent paper. The genus *Hyalinia* has the reputation of being a difficult one. No one who has not tried it can fully appreciate how hard it is to bring out in a drawing the really important points of difference between the shells of the various species. In avoiding Scylla we fall into Charybdis, we exaggerate the differences so that the unfortunate collector finds that his shell is not eligible to be this or that or anything at all. The wise and learned gentlemen whose nomenclature we profess to use have fallen into similar difficulties before us. We find that the appropriate name *lucida* has been applied to nearly all the species in turn. *Nitens* has been another rock of stumbling; and when we examine plates and descriptions of foreign forms, our eventual state of mind and expression of it is liable to be unparliamentary. If we examine the radula of the confused species light begins to dawn. Variation within the limits of the species is here very rare, much rarer in fact than in most other mollusca. A *T. nemoralis* with two or three teeth in each row confused is not an unusual find; but I have never noticed such a thing in the Hyalinæ, unless we reckon *Polita excavata*, Bean., as belonging to the genus *Hyalinia*. The actual number of marginal teeth may vary a little, but very little. *H. cellaria*, Müll., and *H. alliaria*, Miller (figs. 1 and 2 respectively), have somewhat similar arrangements, but there is no chance of confusing the two (1). The central tooth is quite different; the marginals number half as many again in *alliaria*. These examples are interesting as showing in a marked degree what I take to be the more notable characteristics of the most typical Hyalinæ:

- (a) The central tooth is small in comparison with the laterals and marginals;
- (b) There is a very small number of laterals, three only in the case of these two species;
- (c) The marginals are very long, and have only one point; they are never bifid as in *Conulus fulvus*, etc.

If we now look at fig. 3 (*H. pura*, Ald.) and fig. 4 (*H. nitidula*, Drap.), we find a departure from this very definite type. The central tooth is about the same size as its neighbours, a condition which

is, so far as I know, found in all other British Pulmonata, except *Testacella*, in which it is remarkably small, and the typical Hyalinæ already mentioned. *Pura* has still the orthodox three laterals only, but *nitidula* has four, and one transitional tooth which resembles the marginals, except for its being bicuspid to a small extent. When we get to the species forming the great bulk of the old genus *Helix*, we shall find that transitional teeth are so frequent that it is practically impossible to draw the line between marginals and laterals (1).

In figs. 3 and 4 we note again that *pura* has a great many more marginals than *alliaria* or *cellaria*, and that the otherwise more aberrant *nitidula* has more still. They are not all shown in fig. 4; the type remains the same throughout, but the extreme ones dwindle down to a very small size. This increase in numbers is accompanied by a diminution of size in the individual marginals, but as yet each tooth is only single-pointed, and of the regular form which we associate with the marginals of *Hyalinia*.

From *Hyalinia* to *Agriolimax* (*A. laevis*, Müll., fig. 5) may seem a great leap, but perhaps it is not so great as we should be inclined to think. Here we see that the teeth are individually quite of the *Hyalinia* type, but in respect of numbers there is considerable difference. There are eleven laterals and about twenty marginals, the transition being much less abrupt, but yet not by any means difficult to make out. On account of the large number of small teeth I have only drawn a typical lateral and the first and last marginal.

There are several groups which formed part of the old genus *Zonites*, as understood by Gwyn Jeffreys and Moquin-Tandon, which for various reasons have been or are being split off from our Hyalinæ. We have, for example, the *Polita* group (*P. excavata*, Bean., fig. 6), which pleads guilty to the possession of that very improper instrument for a *Hyalinia*, the spiculum amoris, or "love-dart" (2). *Polita excavata* is not very much unlike *nitidula* in respect of tongue, but it has nine laterals, instead of four, and its rather numerous marginals, though not bicuspid, are relatively small. The arrange-

(1) I use these terms in the sense in which they are found in Mr. Taylor's Monograph (p. 152), the laterals being those which are immediately at the sides of the central tooth, and the marginals the remainder from the last distinct lateral to the outside edge. This is also the usage of Pilsbry and most modern authorities. It seems likely that the laterals are homologous with the highly-developed teeth of the Pectinibranchiata, and the marginals with the unci, which sometimes occur in that group. Some support is given to this view by the fact that where the laterals are abruptly distinguished from the marginals they are generally more elaborate and fewer in number. The figures accompanying the present paper will show this to be true in the case of this particular group. The further inference, which I need not press any more at present, is that *Hyalinia* is the prototype of a great part of the Pulmonata, *Vitrina*, *Testacella* and *Limax* branching off from it in one direction, and *Arion*, *Patula*, etc., in another.

(2) It is right to add that this organ is supposed not to be homologous with the spiculum of the Helicidæ.

(1) Since writing the above, Mr. W. Moss has most kindly furnished me with a photograph of the radula of *H. glabra*, Stud. The true *glabra* appears to be rare in Britain; but I propose to treat more fully of this question in a subsequent paper.



ment of the basal plates is strongly suggestive of *Helix*, and in an unstained preparation the whole thing looks utterly unlike *Zonites*, but the transition is as abrupt as can be wished.

*Conulus fulvus* (fig. 7) introduces us to a new state of things. There are eight distinct laterals, and so far, except in their number, no great deviation from the *Hyalinia* type; but the marginals are now very distinctly bicuspid, and their basal plates are elongated in an opposite direction to that usual with the species we have been discussing. This kind of basal plate is what we meet with in the regular *Helicidæ* and the *Pupidæ*.

To return to the laterals. In *cellaria* (fig. 1) and *alliarina* (fig. 2) there is an endocone and a mesocone. In the second group, represented here by *pura* (fig. 3) and *nitidula* (fig. 4), there is a mesocone and an ectocone; but in *Conulus* we have all three points distinct. There is a slight indication of the endocone in *Agriolimax* (fig. 5). It is practically important not to confuse these points with the edges of the basal plates, as is easily done if the preparation is not stained.

The curious continental species, *Calcarina candidissima*, Dr., was placed with some hesitation by Moquin-Tandon amongst the *Zonites*. Fig. 8 shows samples from its radula, and it is pretty safe to say that if allied to *Hyalinia* at all it must be a very distant cousin. The figure shows the form of the teeth, as usual, at the newly-formed edge of the odontophore, and though they certainly suggest some amount of detrition this is not actually the case. Fig. 9 shows the teeth of *Vitrina pellucida*, Müll. There is a good deal of general resemblance to *Conulus*, both in numbers and in form; but the marginals are more *Zonitoid* in the form of their basal plates, and the transition is more abrupt.

It is not proposed to found any hasty gene-

realizations on the foregoing facts. My object is rather to demonstrate to such fellow snail-hunters as may read these pages, what an interesting field of study is here opened, and to suggest, if I may venture, that it may be patronised more largely. It may be worth while to add that of all distinctive characters which I have yet examined in a comparative way, the odontophore seems to offer the most constant. It would be absurd, of course, to classify according to tongues only, but we certainly ought to amass and arrange all the information we can about this interesting organ. There is much work to do, especially as too many of the old records on the subject are inadequate because of imperfect microscopical methods.

As most people are aware, we find the minute structures of animals less liable to variation than the parts which are, on account of their size, more in evidence. Thus, amongst the snails, of whose radulæ we have spoken above, it would be quite easy to find a specimen of *H. radiatula* bearing a sufficiently close resemblance to *cellaria* to deceive any naturalist who had not given the genus his special attention. Such instances might be multiplied almost *ad lib*, for they seem to occur in every part of the animal kingdom, but more especially amongst invertebrates. The explanation appears to be that there has been a great

deal of convergence of typical form with respect to the exterior characters, a convergence produced doubtless by similar climatic conditions; while those parts of the animal which are not concerned with protection or climatic adjustment retain for the most part their primitive organization. These are matters of detail which still require close study, and that study should be diligently pursued by all naturalists who take an interest in the Invertebrata.

(To be continued.)

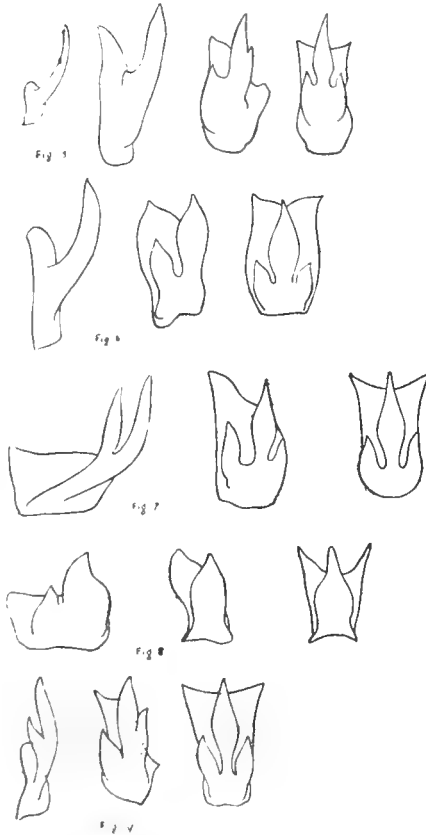

ODONTOPHORES OF MOLLUSCA.

Fig. 5, *Agriolimax laevis*; fig. 6, *Polita excavata*;  
fig. 7, *Conulus fulvus*; fig. 8, *Calcarina candidissima*;  
fig. 9, *Vitrina pellucida*.

## ARMATURE OF HELICOID LANDSHELLS,

WITH A NEW SPECIES OF PLECTOPYLIS.

BY G. K. GUDE, F.Z.S.

(Continued from Vol. iii., page 332.)

*PLECTOPYLIS muspratti* (<sup>1</sup>) (figs. 45a-f). With a number of *Plectopylis* kindly sent to me by Colonel Beddome for inspection, were three shells which he thought would prove to be new. Upon examination I found them to differ from all the described species, and now, therefore, publish this form as a new species under the above name, which was suggested by Colonel Beddome. *Plectopylis muspratti* in outward appearance somewhat resembles *Plectopylis nagaensis* (vol. iii., p. 206, fig. 33), but the armature is quite different. The parietal armature (see figs. 45e and d) consists

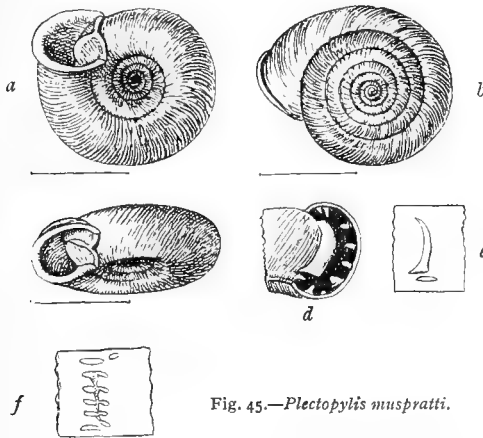
Fig. 45.—*Plectopylis muspratti*.

of a strong, vertical lunate plate, strongly deflected posteriorly below, the convex side towards the

(<sup>1</sup>) *Plectopylis muspratti*, n. sp. (figs. 45a-f).—Shell sinistral, discoid, widely and deeply umbilicated, pale corneous, streaked transversely with dull brown; finely striated and decussated with spiral lines, which are very distinct on the upper surface, but less so below. Suture impressed, spine a little conical. Whorls six and a half, scarcely convex, slowly increasing, the last widening towards the aperture, slightly angular above, descending suddenly in front, and a little constricted behind the peristome. Aperture roundly lunate, peristome white, thickened and reflexed margins converging. Parietal callus with a strongly raised flexuous ridge, which is separated from both margins by a little notch. Umbilicus wide and deep. Parietal wall with a short entering flexuous fold united to the ridge at the aperture, becoming attenuated inwardly, and at one-third of the circumference from the aperture, with a strong, crescent-shaped vertical plate, which is suddenly deflected posteriorly at the lower extremity; below this, on the anterior side, occurs a very short, horizontal fold. Palatal folds six, horizontal, short; the first free, with a small denticle posteriorly; the second, third, fourth, and fifth connected with each other by a vertical ridge, which deflects below the fifth fold posteriorly and terminates in a small, oblique denticle; the sixth again free. —Major diameter, 13 millimetres; minor diameter, 11 millimetres; axis, 6 millimetres.—Habitat, Naga Hills, Assam. —Type in Colonel Beddome's collection.

aperture; below, on the anterior side, is a very short horizontal fold; a short, entering, flexuous, horizontal fold occurs at the aperture and is joined to the flexuous raised ridge which unites the two margins of the peristome. The palatal armature consists of: first, a free, short, horizontal fold with a small denticle posteriorly; next, four short, horizontal folds connected by a slight vertical ridge about their middle; the posterior halves of the folds being thinner and slighter than the anterior halves; the vertical ridge is continued below the fifth fold, where it suddenly deflects posteriorly and terminates in a small oblique denticle; below the fifth fold, a little nearer to the aperture, is found a sixth fold, which, like the first, is quite free (see fig. 45f, which shows the inner side of part of the outer wall with its palatal folds, and fig. 45d, which gives the posterior view of the parietal and palatal armatures).

*Plectopylis macromphalus* (figs. 46a and b) was described and figured by Mr. W. T. Blanford in the "Journal of the Asiatic Society of Bengal," xxxix. (1870), part 2, p. 17, t. 3, f. 14, and in Hanley and Theobald's "Conchologia Indica," t. 83, ff. 8-10. The armature was figured by Lieut.-Colonel Godwin-Austen in the "Proceedings of the Zoological Society," 1874, t. 73, f. 1. The species has been recorded from the Khasia, Dafia and Naga Hills, in Assam. The shell is sinistral, widely umbilicated, light corneous, with incremental curved plicae, decussated by spiral lirae above, somewhat smooth and shining below. It is composed of  $4\frac{1}{2}$  to  $5\frac{1}{2}$  flattened narrow whorls, the last being scarcely wider, subangulate above, a little descending in front. The peristome is whitish, a little thickened and reflexed, slightly

Fig. 46.—*Plectopylis macromphalus*.

flattened on the upper, outer margin; the margins converge a little, and are joined by a thin callus on the parietal wall. The parietal armature (see fig. 46a) consists of a strong vertical plate, which has a minute, slightly elongated, horizontal denticle posteriorly to its lower extremity. The palatal armature is in two series (see fig. 46b, which shows the inside of the outer wall). The anterior series

is composed of four short, broad, flattened, straight horizontal folds. The posterior series consists of ix narrow horizontal folds, which are shorter than those of the anterior series; the fourth and fifth are a little obliquely depressed posteriorly. The specimen is in Mr. Ponsonby's collection, and measures 6 millimetres in diameter. Two specimens in my collection also measure 6 millimetres in diameter.

*Plectopylis minor* (figs. 47a-l), from Darjeeling, was described by Lieut.-Colonel Godwin-Austen in the "Annals and Magazine of Natural History" (5), iv. (1879), p. 164. As the species has never, to my knowledge, been figured, I have much pleasure in illustrating it. Mr. W. T. Blanford mentioned a var. *minor* of *Plectopylis macromphalus* in the "Journal of the Asiatic Society of Bengal," xxxix. (1870), part 2, p. 18, which is probably the same form. The shell is sinistral, openly umbilicated, discoid, hirsute, finely ribbed, decussated by spiral lirae above, pale corneous with equidistant transverse brown striae; the spire is a little raised, the suture impressed. There are five regularly coiled

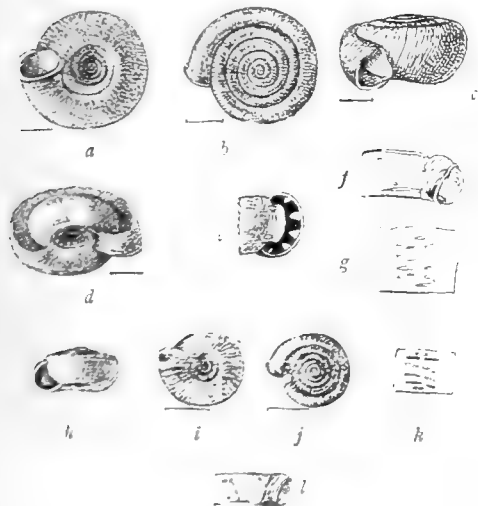

FIG. 47.—*Plectopylis minor*.

whorls, the last being sub-angular at the periphery, a little wider than the preceding whorl and a little descending in front. The cuticle is produced into distant, transverse, brownish, raised plaits, which are each provided with four coarse, deciduous hairs, forming four lines which pass round the body whorl. The aperture is lunate, flattened on the upper outer margin, and a little oblique. The peristome is white, a little thickened and reflexed, the margins are connected by a slightly raised ridge on the parietal callus. The umbilicus is moderately deep and wide, but narrower than in *Plectopylis macromphalus*. The parietal armature

consists of a strong vertical plate, a little deflexed below anteriorly, having posteriorly two minute denticles, one above and one below. A very thin, free horizontal fold occurs below the vertical plate, revolving as far as the parietal ridge at the aperture, where it becomes much attenuated (see fig. 47f.); this fold appears to be somewhat variable, for in a specimen in Mr. Ponsonby's collection, shown in fig. 47l, it is very short, and scarcely extends beyond the vertical plate; while in another specimen, also in Mr. Ponsonby's collection, shown in fig. 47d, it is absent altogether. Lieut.-Colonel Godwin-Austen, in his description of the species, states: "Parietal vertical, lamina simple, with no distinct horizontal plica below it."

The palatal armature is in two series, the anterior series consists of four thin horizontal folds, and the posterior series of six horizontal folds, the first of which is very minute, the next four a little broader and shorter than those of the anterior series, the fourth and fifth a little deflexed posteriorly, and the sixth very small and thin (see figs. 47g). The specimen shown in figs. 47a-e is in Mr. Ponsonby's collection, and measures—major diam., 5 millimetres; minor diam., 4 millimetres; alt. 2.5 millimetres. The one shown in figs. 47f and g is in my collection, while that shown in figs. 47h-l belongs to Mr. Ponsonby, who informs me that it was obtained from Mr. Hungerford, labelled, "*P. plectostoma* from Sikkim." At first I was inclined to refer this specimen to *Plectopylis hanleyi*, but upon further examination it appears to me to pertain to the species now under consideration; the measurements are the same as in the specimen from Darjeeling. An immature specimen in my collection, with four whorls completed, has the armature near the end of the fourth whorl, and identical with that of a mature shell, except that it is smaller. A specimen in Colonel Beddome's collection, from the Naga Hills, labelled with the manuscript name, *Plectopylis minuta*, Bedd., I also refer to this species; it is, however, a little smaller, measuring only 4 millimetres in diameter; it is also a little more raised in the spire, and is more shining and darker.

(To be continued.)

ABNORMAL MARSH-MARIGOLD.—While observing specimens of *Caltha palustris*, I met with a curious sport, viz., a flower bearing all its parts in perfect order, but in addition to its five coloured sepals, about one inch below the flower on the flower-stalk, bearing an additional petaloid sepal, giving the appearance of a coloured bract. This seemed to me a rather unique form.—John J. Ward, 15, Foleshill Road, Coventry; 12th May, 1897.

## ROYAL SOCIETY'S SOIRÉE.

THERE was the usual brilliant gathering at Burlington House on the evening of May 19th, at the Soirée of the Royal Society. The exhibits were as diversified as formerly, and the votaries of nearly every branch of science found some specially interesting feature bearing on their studies. Physicists who work in investigation of electrical phenomena surrounded Mr. Wimshurst's remarkable new machine for producing a spark of thirty-four inches between the terminals and twelve feet on the tables. This is three times the power of his former construction. Professor Roberts-Austen showed his combined camera-microscope which takes wonderful micro-photographs of metals and alloys under high magnifications. As an instance, carbon is shown in steel as minute diamonds. Dr. Norman Lockyer sent a series of photographs taken in Nova Zembla and at Kio Island during the visit there on the Solar Eclipse Expedition last year. These include one of importance—of the chromosphere of the sun, of which it is probable more will yet be heard. Spectrum researches were well in evidence. Zeeman's discovery was demonstrated for broadening the spectrum lines by the action of a magnetic-field on the source of light. The analysis of stellar light was illustrated by Dr. Norman Lockyer, by a series of wonderfully accurate photographs of the spectrum. The Astronomer Royal contributed splendid photographs of the moon, taken by the new Thompson 26-inch telescope at Greenwich. These are taken by an enlarging lens at secondary focus, equivalent to a focal length of 105 feet. Other views of the moon were by Loewy and Puiseux, published by the Paris Observatory. Further exhibits of physical interest were by Mr. J. W. Swan, of the effects of convective electrical discharges upon viscous resinous surfaces; and he explained the mode of preservation of such surfaces for future examination. The duration of explosion, pressure generated, and other effects were exhibited by an apparatus invented by Sir Andrew Noble, of Elswick. The transmission of the Hertz wave-motion was shown by a most ingenious model arranged by Professor Sylvanus Thompson. Mr. Eric Stuart Bruce lent a remarkable series of photographs of optical projections in space. The instrument for their creation is not new, but its application in conjunction with a camera has produced some wonderful photographs which would be dear to the hearts of enthusiastic spiritualists. Mr. J. Gould conducted attractive experiments on the transmutation of sound. Sir David Salomons had a rotating mirror running at the rate of 48,000 revolutions per minute. Messrs. Barnard and Carver showed a new means of controlling an

electric arc. Professor Ayrton lectured during the evening on "Electrical and Mechanical Analogues."

Biology was represented by a considerable exhibit by the Marine Biological Association, from the biological station at Plymouth, in illustration of commensalism, or the association, whilst living, of different marine animals for their mutual benefit. These included the frequently-shown instances of hermit-crabs and sea-anemones; also that of *Nereis*, a worm which lives in the upper whorls of a whelk-shell, and comes down for food: *Eupagurus*, also a hermit-crab, and its companion anemone; a worm (*Acholoe*) which lives in a groove under a starfish; another worm (*Malmgrenia*) living in similar manner on heart-urchins. These and some other animals in like association formed an important exhibit. The effect of heat during the pupa state upon the alteration of colouration of certain lepidoptera was shown by examples sent by Mr. F. Merrifield, of Brighton, and Dr. Standfuss, of Zürich. Ethnology was represented by Mr. Warren, with bones found by Professor Flinders Petrie, in Egypt, of the ancient Naquada race, which existed some five thousand years ago. Africa also sent, through Mr. J. E. S. Moore, animals of varied forms from Lake Tanganyika. Biologists were favoured by the opportunity of hearing Professor J. B. Farmer lecture on "Nuclear Division in Animal and Vegetable Cells."

## NATURAL HISTORY EXHIBITION.

THE City of London Entomological and Natural History Society held a successful exhibition on April 27th, at the London Institution, Finsbury Circus. Besides the members of the society, many leading entomologists kindly contributed exhibits. Mr. J. A. Clark sent full representation of all our known British butterflies, amongst which were a long series of male and female *Chrysophanus dispar*, hermaphrodite specimens of *Dryas (Argynnis) paphia*, *Plebeius (Polyommatus) agon*, *Polyommatus icarus*, and black vars. of *Limenitis sibylla*. Aberations in Mr. C. Nicholson's Vanessids included: *Pyrameis atalanta*, with partial bleaching of red band on right-hand wing; *P. cardui*, with an additional white spot on fore-wings; and *Aglais (Vanessa) urticae*, approaching var. *ichnusa*. Mr. A. W. Dennis, a xanthic *Epinephela janira*, *Pararge egeria*, female, with male colouration; *Pyrameis cardui*, much suffused with black: *Argynnis adippe*, with median black band on all wings; *Cupido (Polyommatus) minima*, undersides with spots obsolete; *Spilosoma lubricipeda*, with central fascia on all wings; *S. menthastris*, with spots much enlarged. Mr. Robt. Adkin, all known British species of "clear-wings," series of *Endromis versicolor*, *Lasiocampa quercifolia* and *L. ilicifolia*,

etc., *Campogramma bilineata* (black forms from Kerry and banded from Shetland), banded *Thera juniferata* from Orkney, black *Amphidasys betularia* from Yorkshire, vars. of *Boarmia repandata* and *Abraxas grossulariata*. Mr. J. W. Tutt's Zygænid included *Zygæna hippocrepidis*, a species usually confounded with *Z. filifendulæ*; amongst his Geometers were a series of aberrations of *Cidaria immanata* from Lochgoilhead, and a hybrid between *Amphidasys strataria* and *A. betularia*. Mr. W. M. Christy, *Zygæna filifendulæ* and *Z. trifolii*, with vars. *Macroglossa bombyliformis*, with scales all over the wings, as found prior to their use, and *Nyssia lapponaria*, with *N. zonaria* and Continental relatives for comparison. Mr. C. G. Barrett, British and European Psychids, with their curious larva-cases; long and variable series of *Agrotis ursoria* and *A. tritici*; Leucaniidæ, with *Leucania favicolor*, n.sp., lately determined by himself, and vars. of female, spotted, the latter belonging to Mr. G. F. Mathew; and a moth from Unst, Shetland, agreeing with *Hadena maillardi* (St. Cat.), placed on the table as a form of *Cymodes exulis*, but if of specific rank would be an addition to British fauna. Typical *C. exulis* and one intermediate form belonging to Mr. Percy M. Bright were also exhibited. Mr. F. J. Hanbury, Noctuidæ, *Noctua festiva* var. *conflua* being largely represented, and the Xanthidæ and Catocalæ were much admired. Mr. L. B. Prout, bred series of *Coremia ferrugata* and *C. unidentaria* to illustrate the influence of heredity. Mr. G. Elisha, a fine exhibit of twenty drawers of micro-lepidoptera of the greatest beauty as to freshness of moths and regularity of setting. Mr. D. C. Bate, larva of *Orgyia gonostigma*. Mr. J. Riches, larvæ of *Afamea ophiogramma* on their food-plant, variegated ribbon-grass. Mr. C. Nicholson, preserved larva of *Lasiocampa quercifolia*, showing the "lappels." Mr. S. Edwards, a valuable and immense collection of *Papilioninæ* from all regions. Exotic lepidoptera were exhibited by Messrs. J. A. Clark (Morphinæ, Atlas, Cecropia, *Thysania agrifpina*, etc.), A. Bacot (South African), E. M. Dadd (American) and Dr. J. S. Sequeira (Indian). The subject of "Mimicry," or the assumption by persecuted species of similar or nearly similar colouration to that of species protected by scents, colours, or presumed nauseousness of flavour, from birds and animals, was well illustrated by Messrs. Watkins and Doncaster and Messrs. O. E. Janson and Son. Mr. H. Heasler, coleoptera, being the material for his "London List," which includes *Molophilus minor*, *Oodes helophodes*, *Aphodius lucidus*, *Rhinoncus bruchoides*. Messrs. O. E. Janson and Son, case of Phasmidæ or stick insects, twig-like when quiescent—a further development of the "protective mimicry" principle. Mr. W. J. Ashdown, *Olonata*, showing the *Anax imperator* and *Leptetrum quadrimaculata* var. *fræmibula*,

can be captured in Surrey. Mr. J. A. Clark, nests of *vespa britannica* from Forres, on fir, birch and heather, and from New Forest on ivy and yew. Dr. J. S. Sequeira, "insect products," such as silk, wax, honey, cochineal, shellac, etc. Mr. R. M. Wattson's "life in a pond" exhibited dragon-fly nymphs, water-beetles, water-scorpions and other inhabitants of our ponds and pools. Mr. D. C. Bate, a "cat's-eye" electric lamp for sugaring. Mr. R. A. Adkin, mollusca: *Turricula terrestris* (*Helix elegans*), from Dover; a large *Limnæa peregra*, with body whorl abnormally humped. Mr. G. K. Gude beautiful varieties of Helices. Mr. C. Oldham, polished agates; also mosses and lichens from Merioneth. Mr. F. J. Hanbury, Italian Alpine plants and rare or extinct British plants. Comm. Thomas Hanbury, fresh fruits and curious seed-pods from La Mortola, Vintimiglia, Italy, including many varieties of *Citron* and *Solanum*; *Ficus repens*, the climbing-fig; *Eucalyptus globulus*, the blue-gum; also the "bottle-brush," from Australia; cotton, sissal hemp, and seed-pods of *Canavalia ensiformis*, *Martynia proboscidea* (the "wait-a-bit" thorn), and *Pithecoctenium muricatum* (family Bignoniaceæ), a double-valved husk covered with blunt spines, holding innumerable closely-packed winged seeds, with a hinged "septum" between the valves. Birds' eggs were shown by Messrs. A. F. and W. M. Bayne and F. S. Cottell. Cases of birds and mammals adorned the side tables, Mr. F. J. Hanbury exhibiting terns, corncrake, shrews, pole-cats (rapidly becoming extinct in this country). Mr. J. A. Clark, rotche, smew (male and female), cinnamon-coloured blackbirds; and Dr. J. S. Sequeira, great northern diver, laughing-jackass, sirral cat (a musteline) and porcupine ant-eater (*Echidna hystrix*). Microscopists displayed *Melicerta confiera* and *Stephanoceros eichornii* (tube-building rotifers), *Lophopus crystallina*, *Plumatella repens*, *Volvox globator*, etc. Dr. W. A. Kibbler exhibited illuminated photo-micrographs. Gerard Smith, Esq., M.R.C.S., etc., gave a demonstration of X-rays phenomena twice during the evening, and Mr. Fred. Enock, in his happiest style, gave a lecture on "The British Trap-door Spider." Lord Walsingham, an honorary member of the Society, visited the soirée early and addressed the members on the value and pleasure of a study of nature. A programme of music was delightfully rendered in the course of the evening, and light refreshments were served to all visitors.

H. A. SAUZÉ.

1, Mount Villas,  
Sydenham Hill Road, London, S.E.

PRESIDENT MCKINLEY and Secretary Sherman have recommended that Congress shall make an appropriation of \$350,000 for the representation of the United States at the Paris Exposition of 1900.

## PHYSICAL AND MECHANICAL DISINFECTION.

A MEETING of the members of the Civil and Mechanical Engineers' Society was held on April 22nd, in the Westminster Palace Hotel, when a paper on "Physical and Mechanical Disinfection" was read by Mr. W. Noble Twelvetrees. This subject, interesting alike to civil engineers and others concerned in municipal affairs, was dealt with in a comprehensive manner and illustrated by a number of interesting diagrams showing the various forms of apparatus used in laboratory practice and in public institutions.

Favoured inhabitants of the world in the present year of grace are perhaps occasionally apt to overlook the useful work done in past generations, and those who imagine that efficient hygienic regulations originated during the present epoch are reminded by Mr. Twelvetrees that, in the earliest ages, disinfection and sanitary precautions received due attention. Amongst the earliest evidences of this fact, are mentioned the laws of Moses and of Lycurgus, and of heathen religious practices, all showing an intelligent recognition of the value of disinfection. Having called attention to the practical good sense the ancient Romans evidenced by their attention to drainage, ventilation and water-supply, and by the appointment of State physicians in their cities and towns, the writer pointed out that in the middle ages the civilized world suffered a relapse, diseases and epidemics being regarded as "dispensations of Providence, which it would be sinful to combat, save by prayer and penance." The growth of a revived interest in sanitary science was next traced, also the recent development of the germ theory, which, aided by the practical science of bacteriology, has rendered the most invaluable assistance to those responsible for promoting the health and well-being of the community.

Speaking of bacteria, or micro-organisms, which have been proved by eminent men of science to be at the root of all diseases, and injurious changes in organic substances, Mr. Twelvetrees remarked, "It is probably not exaggerating matters to say, that the self-respecting citizen has no better opinion of a microbe than an ordinary police magistrate has of a cyclist." He pointed out, however, that the large majority of these omnipresent organisms performed useful work by resolving organic substances into their constituent elements. The physical forms and characteristics of micro-organisms were next dealt with as affording an indication of the means to be adopted for extirpating or reducing the numbers of harmful species.

Mr. Twelvetrees next described and illustrated the various forms of collecting, cultivating and

sterilizing apparatus in laboratory use, then proceeded to discuss the question of disinfection by physical means. The drawbacks attached to the use of hot air appear to be the high temperature required and the length of time necessary for sterilization. Steam is recommended as the most efficient and convenient agent, but an important distinction is drawn between the relative values of superheated and saturated steam, the former, at a temperature of 285° F., being no more efficient than hot air, whereas the latter, even at 214° F., is extremely rapid in effecting sterilization. Saturated steam may be applied in modern apparatus, either under varying pressures or in the form of a continuous current, at atmospheric pressure. The leading types of English, Continental and American apparatus were fully described and illustrated, the results of experiments by leading authorities being quoted in detail. Among English forms of apparatus one including a novel and ingenious feature is that invented by Dr. Thresh, Medical Officer of Health for the County of Essex. The "Thresh" Disinfecter, used on the "current steam" system, utilises the well-known physical fact that water containing substances in solution possesses a boiling point proportional to the specific gravity of the liquid. By using a solution of calcium chloride (specific gravity, 1.36) a temperature of 225° F. is attained, steam being given off at about 220° F., thus ensuring absolute sterilizing efficiency. The apparatus is very simple in construction, and being open to atmospheric pressure there can be no risk of explosion.

Mr. Twelvetrees next illustrated the most important points to be observed in the construction of public disinfecting stations, and passed on to the consideration of incineration as a means of destroying infectious matter which is not of sufficient value or is otherwise unsuitable for treatment in an ordinary apparatus. Chemical disinfection, according to authorities quoted, though not without its uses, is not to be regarded as a satisfactory means of sterilization. Mechanical disinfection, including natural and artificial filtration, was discussed somewhat fully, as being of the greatest public importance. Sand filtration has been found by Dr. Frankland to remove 98.4 per cent. of the organisms from Thames water. The assistance rendered to filtration by settling reservoirs, in which the water is purified by deposition, by oxidization, and by the destruction of harmful germs by inoffensive species was instanced, as also the valuable results obtained by the use on a large scale of the Porter-Clark and other systems of water-softening apparatus.

After a reference to the desirability of pure and abundant water supplies, Mr. Twelvetrees pointed out in conclusion that disinfection, in the widest sense of the term, involves much more than comparatively limited processes in public disinfecting stations, and that nothing short of universally-

created hygienic conditions will remove from our homes the evil presence of disease, and enable the weak and sickly children of our large towns to grow up into "healthy citizens, strong and ready to bear their part bravely in the great battle of life."

## CONTRIBUTIONS TO THE LIFE-HISTORIES OF PLANTS.

BY THOMAS MEEHAN. (1)

### PELLUCID DOTS IN HYPERICUM.

MANY species of *Hypericum* present small black dots on the stems, leaves or other portions of the plant. In *H. corymbosum*, Muhl., the stem and lower leaves have these dots profusely scattered over the surface, those on the stem being generally somewhat elongated, after the manner of suber cells as usually seen in the young bark or epidermis of woody plants. Examining the series of leaves in succession up the stem, we find the uppermost leaves nearly destitute of black dots, a few being found chiefly near the margin. Starting again from below upward, we find that as we advance, the pellucid dots, wholly absent in the lowermost leaves, begin to be comparatively scarce near the midrib. As they come into existence, the black dots disappear. The pellucid dots increase in numbers with each series of leaves—the black dots seem to give up the ground to the pellucid ones—till, when the much-reduced leaves beneath the flower are reached, scarcely any but the pellucid dots are found. They reappear again in numbers on the petals.

It is singular that though there is an evident correspondence in the increase of pellucid dots and the decrease of the black dots, no genetic relationship can be discovered. In no instance was there any evidence of a transmutation of a black dot to a pellucid one.

The dotted structure of other species growing on my ground was therefore examined. These were *Hypericum perforatum*, *H. buckleyi*, *H. kalmianum* of our country, and *H. androsæmum*, *H. calycinum* and *H. moserianum* of the old world. *H. perforatum* furnished the most interesting subject for comparison. The lower leaves, given up wholly to black dots in *H. corymbosum*, had only pellucid dots, and in none of these were black dots numerous. Indeed, it was only in the uppermost leaves that a few black dots were found, and these sparingly distributed near the outer edges. On the petals also the black dots are sparingly found.

It is apparent from what has been stated in regard to *H. corymbosum* that the energy productive of the black dots is different in degree from that

productive of pellucid dots. We may further conclude that these varying degrees of growth-energy had but little to do with the differentiation of these two species. One species could readily be transformed to the other as each degree of energy was in control. In *H. kalmianum* and *H. buckleyi* pellucid dots are profuse. No trace of black dots could be found. From what has been already noted, they are not to be expected where the pellucid dots abound.

In the European *H. androsæmum* the whole surface is minutely pellucid-punctate. The midrib and veins are also pellucid. At various points along the lines of these veins are, however, small swellings, more or less orbicular, as if they had been originally pellucid dots, and that lines had been thrown out to connect the dots with each other. In *H. calycinum* there are similar connections, and beside a few scattered pellucid dots; but these are not round but pyriform, one end tapering into a narrow tail. If a little more prolonged, we shall have just such connections as we find in *H. androsæmum*. In *H. moserianum*, we find the surface profusely covered with dots, not very pellucid, apparent though they are when held up to a bright light. Some of these are wholly individualized and isolated, but others have sent out a line as yet unconnected, but the great majority have had the lines connected, and have formed a mass of reticulated veinlets unequalled in any other species I have seen. Turning to *Hypericum prolificum* I find many semi-pellucid dots in the petals, especially near the margin, and some of them elongated, and in a number of cases they have met others and formed an elongated pellucid vein.

I think these pellucid dots are the initial steps taken by the plant in the formation of veinlets and veins. It cannot for an instant be conceived that nature first makes a skeleton leaf and then covers it with parenchymatous tissue. These strengthening ribs must be constructed out of cell-tissue only as the organism needs them. And this construction can only go on under a regularly arranged system. There can be no theoretical reason against the view I have taken of the nature and office of these pellucid dots.

(1) Extracts from papers read before the Academy of Natural Sciences of Philadelphia.

I think little has been written regarding the variable character of these dots. The only author I have found is Bromfield, who was, in a measure, my early patron and preceptor in botanical study. In "Flora Vectensis," writing of *H. perforatum*, he takes occasion to note the difference in the character of the dots in various species, which, in some, take the form of anastomosing pellucid veins. "I do not find," he concludes, "any notice taken of this character by any author I have consulted." I have seen none since his work appeared in 1856.

#### ORIGIN OF THE FORMS OF FLOWERS.

In my intercourse with intelligent and observing botanists, who frequently do not place their conclusions on record, I find a growing tendency to discredit views, till recently widely prevalent, that external conditions have any more than a feeble influence on the evolution of the forms of flowers. Thought is in the direction that various degrees of internal energy seem rather the chief agents in effecting change.

Listening to some verbal remarks before the Botanical Club of the American Association for the Advancement of Science, at Buffalo, New York, by Mr. David F. Day, I was struck by his point that irregular flowers were usually associated with the curving or twisting of the peduncle, while regular flowers and straight peduncles were usually closely related. I saw this subsequently well illustrated in lilies. In the class to which belong *Lilium philadelphicum* and *L. catesbaei*, the upright flowers are perfectly regular; irregularity, in some of the floral parts, characterizing the nodding ones. The nodding peduncles, after flowering, become erect, and in the seed-bearing stage the seed-vessels are erect on perfectly straight peduncles in both classes. It is evident from this fact that in the species with drooping flowers the expansion of the perianth occurred before the uncoiling energy had been exhausted, and during a rhythmic rest. It is further evident that the growth-waves prevailing in the development of the flower varied in intensity in different parts, and that varying forms must necessarily follow from these varying degrees of energy. Unequal pressure by reason of the curve ought to be accountable for this inequality. It is, however, evident that outside agencies could not have had much, if any, influence in the curving which results in irregularities of these lilies. Some excellent illustrations are often seen where an erect flower occasionally occurs on a plant which generally has the pedicels more or less curved. Some gloxinias and other Gesneriaceous plants will readily recur to the intelligent observer. *Gesneria elongata*, a South American species, popular in garden culture, often has these erect flowers. In this case the flowers are perfectly regular, and of a different character in other respects from the normal ones.

(To be continued.)

## SCIENCE AND ART MUSEUMS.

SIR JOHN GORST'S Committee on the Museums of the Science and Art Department, in consequence of the evidence brought before it and the personal examination by its members, of the buildings at South Kensington, has issued an interim report urgently drawing the attention of Parliament to the peril to which the priceless collections are exposed of destruction by fire. The Committee consider that such a lamentable event might have long ago occurred but for the great care exercised by the police in charge. The buildings are at best only temporary, and largely constructed of varnished wood, lath and plaster. The Committee recommend that the exhibits should be immediately withdrawn from public inspection, and the buildings properly constructed and completed. Considering that the Kensington Science and Art collection is almost unequalled in value, we imagine the public would not begrudge the spending department at once finishing the permanent buildings for its housing.

## RÖNTGEN RAYS PICTURES OF SHELLS.

WE are indebted to Mr. Wilfred Mark Webb, F.L.S., for the use of the accompanying interesting "sciagraphs" of shells, which appeared as Plate iii. of "The Journal of Malacology" for May (vol. vi., No. 1). The portraits were taken by Messrs. W. Watson and Sons, of High Holborn, London, for Mr. Webb's journal. They show how useful the Röntgen rays may be for examining the inner structure of a shell, and suggest quite a new means of studying the interiors without having to break up the shells for that purpose. The following is an explanation of the figures:

Figs. 1 to 7 are a series of shells of a cowry, *Cypraea arabica*, from the South Pacific Isles, showing the changes which take place during growth.

Figs. 1 and 2.—Young specimens in which the shell is a simple spiral one with a thin unreflected lip. N.B.—The spires are somewhat worn at the tip.

Fig. 3.—In this shell the lip has expanded, the edge has curled inwards, and a row of "teeth" is beginning to make its appearance there.

Fig. 4.—Here another row of "teeth" is to be seen on the body of the shell approximately parallel to that on the edge of the lip.

Fig. 5.—This shell is thicker, owing to the deposition of layers of "nacre" upon its outside by the mantle flaps which are protruded by the animal and which cover the shell and meet in the middle line on its dorsal surface. The "teeth" are now more evident.

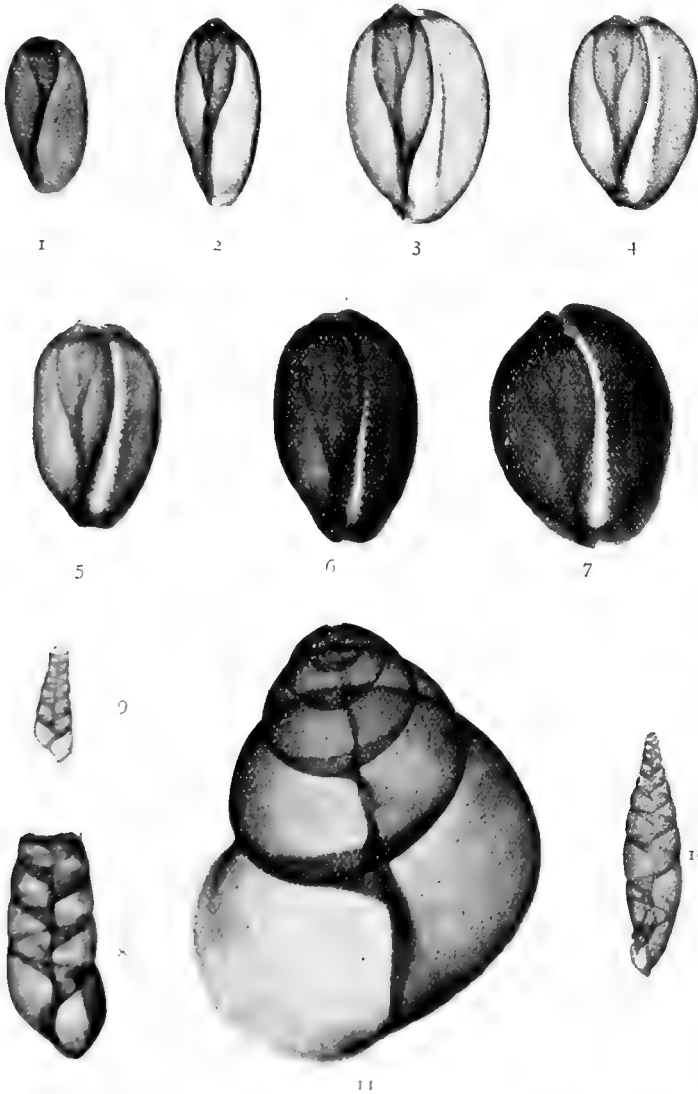

Fig. 6.—The thickening process is being carried on, the shell being considerably heavier and more massive.

Fig. 7.—The adult shell in which almost the maximum of thickening has been reached, and the

which loses its top whorl as it grows; the partition which divided the uninhabited portion of the shell from the rest is shown.

Fig. 9.—A young shell of the same, still retaining its apex, and from its position on the plate



SOME SCIAGRAPHS OF SHELLS.

broadening of the shell achieved: the longitudinal expansion of the lip, too, has now hidden the spire of the younger shell

Figs 8 to 11 are sciagraphs of three landshells which show the columella and the interior of the shell as well as other points noted below

Fig. 8.—A shell of *Bulmus decollatus* from Malta,

showing how much shell has been discarded by fig. 8.

Fig. 10.—*Clausilia swinhoci* from Formosa, showing the clausium or clausilium which guards the entrance of the shell.

Fig. 11.—*Cochlostyla philippinensis* from the Philippine Islands.

## NOTES OF A HOME NATURALIST.

BY MRS. EMILY J. CLIMENSON.

THESE dreadful cold winds are now retarding what promised to be a very forward summer. By April 8th a nest of young robins in our garden were flown. Two swallows were seen flying out of our cowhouse, where there is an annual nest, on April 11th. A cuckoo was heard, first at Shiplake on April 14th, and a nightingale the same night. April 27th a wryneck was heard, and on the 30th a corncrake. Swifts were observed on May 7th. On April 8th I was told of an owl that the gardeners had observed for some three weeks or more sitting in the top of a cedar-tree on a terrace below the house. It was a large wood-owl, and with the exception of a day or two the owl sat in the same tree, on the same branch, for about a month, when it disappeared. The cedar-tree is not twenty yards from the house. As there are five other splendid cedars in our garden, some further from the house, it was singular its choosing this particular one. According to the wind, it sat with its face turned one way or another, motionless the whole day, though at night it was occasionally heard making a loud hooting. Barn-owls breed freely in the chalk pit hard by our garden, but I fancy a wood-owl perching so near the house is rather remarkable.

In a glass jar in the drawing-room window I had a black larva that was quite different from most Ephemeridæ I have kept. It had a broad, black head, two setæ at tail instead of three. The branchial organs were like exquisite feathers, which it continually waved. It could swim rapidly about the jar. Sometimes it lay in the little layer of mud at the bottom, sometimes clung to the *Anacharis* weed. On March 28th, on looking for it, I missed my larva, but instead, on the rim of the vessel, was a beautiful, clear-winged, black insect, with two small wings and two much larger ones, two long setæ as before, minus the claspers which the larva had. It remained on the jar drying its gauze-like wings for two days, and then disappeared. Can anyone tell me what it was? Mr. Bateman, in his book of aquaria, mentions the genus *Baëtis* having only two setæ, but the feather-like branchiæ are not mentioned, which were totally different from any I have had before. Since this I have had another larva like it, except having three setæ unfortunately, for some unexplained cause, it died. In a jar containing a dip from a ditch a perfect eruption of *Hydra viridis* took place on April 28th; they were literally in hundreds. I have never found them before; only possessed those my correspondent, Mr. Nicholson, kindly sent to me.

As I had had the dip for some days without perceiving any, they must have been suddenly born. In the same odd way a fine *Hydra fusca*,

on April 25th, suddenly appeared on a watercress plant, which had been in a jar for a month or more. In the middle of February, Mr. F. O. Warner, our parish schoolmaster, brought me, in a small box, a piece of what he called "animated cotton." It turned out to be a thread-worm (*Gordius*), looking exactly like a piece of Coates' No. 40 white cotton, about four inches long when stretched out, but writhing and twisting itself into veritable gordian knots, lifting a snake-like head, which tapered to a point. I kept it alive for a few days, damping the earth slightly in which it lay, but it died curved into quite an ornamental twist. The colour turned from white to a pale yellow, it was perfectly hard and resembled a piece of twisted vermicelli. I could only see an opaque mass through my microscope, and not having a live-trough, or box, I had not tried to look at it alive. Mr. Warner had found some a year or so before, when digging.

In a wood some three miles from here, on March 26th, I found an uncommon plant *Chrysosplenium alternifolium*, or alternate golden-saxifrage; of course not in flower, only in leaf. As early as the first week in March, a lime hawk-moth (*Smerinthus tiliæ*) was found emerged from a glass frame, and a second in third week of that month. I omitted in my April Notes in SCIENCE-GOSSIP, to mention that the rooks which daily go to the school-house for food come from the rookery some quarter of a mile off; also at the sound of the school bell at two o'clock, in order to search the playground for scraps dropped by the children from their dinner pieces; as well as attending the schoolmaster's meals. They must understand the sound of the bell, as their nests are out of sight of the school house.

*Shiplake Vicarage, Oxon.; May 13th, 1897.*

BRITISH ASSOCIATION.—The preparations for the meeting to be held next autumn, at Toronto, in Canada, are already progressing rapidly, and a hearty welcome is to be offered to the members who attend. Every grade of society in Canada will offer assistance. The Governor-General and Lady Aberdeen are to give a reception in the fine Legislative Buildings in Toronto, which cannot fail to be a success, when we remember the courtesy and kindness which characterize their Excellencies on such occasions. It seems probable that the English visitors may be outnumbered by our American cousins from south of the border-line. Several of the U.S. Universities will officially send delegates, and the Botanical and Geological Societies of America are to meet in Toronto just before the great assembly for the British Association, so that their members may attend the latter gathering. Public banquets are to be given to Lords Kelvin and Lister and to the President-elect, Sir John Evans. The railway companies have arranged for long and short excursions at remarkably low rates. Indeed, the 1897 meeting promises to be a brilliant success.



NOTICES BY JOHN T. CARRINGTON.

**EDWARD DRINKER COPE.**—By the death of Professor Cope America has prematurely lost one of her greatest leaders in science. He died, aged fifty-seven, on the 12th of April last, at his house in Pine Street, Philadelphia, surrounded by his books and his fossils, which had served him to such good purpose. He may be truly said to have died in harness, for on the Tuesday preceding his death he passed for press elaborate articles upon his latest opinions on the classification of the vertebrates. In character he may be shortly described as typical of so many of those who have contributed to the splendid advance of civilization which will make this present century celebrated on the western continent. Thoughtful, consistent, original, and above all guided by a manly independence, Cope will rank as one of America's greatest science teachers. Enthusiasm, as displayed with his judgment, did more than anything else to create a lasting interest in the subjects he expounded. When only seven years old evidence was forthcoming of the natural aptitude for a love of natural history, which was carefully fostered and developed by his father. It was in the neighbourhood of his native city his work began, and he lived to become the leading professor of its University, and there end his days, as one of the world's most learned men of science. In his early days, that is in his later teens, young Cope had many opportunities of studying nature at her wildest in the more remote parts of his native state. At that period his range of investigations included botany as well as zoology. At the age of about nineteen he went to work in the Smithsonian Institution, under Professor Spencer F. Baird, especially upon reptiles. In 1863 Cope travelled in Europe, never losing a chance of enlarging his knowledge in our chief continental museums. He began there his especial studies in ichthyology, in which he was later to become such a learned authority, in connection with his vast palæontological research, which commenced about the year 1865. This was during his professorship of natural science at Haverford College. It was in 1868 that Professor Cope first published his "Synopsis of Extinct Amphibia." As a result he was attached to the U.S. Geological Survey, which gave him splendid opportunities for study of fossils, and so largely helped to found his vast knowledge of prehistoric vertebrate life. Born in Philadelphia on July 28th, 1840, Professor Cope descended from a much-respected line of Quaker ancestors, who had early settled in Pennsylvania. He married, in 1865, Miss Annie Pym, another name well known in the Society of Friends. A list of the works and lesser papers by Professor Cope would indeed be long, and will doubtless appear when a proper biography is undertaken, and such will be certain, for few men's work has been more important. At a meeting of the Academy on April 13th the following minute was passed:—"The Academy of Natural Sciences of Philadelphia has received with profound sorrow the announcement of the death of

Professor Edward Drinker Cope. It is fitting that this meeting should place on record a minute expressive of its sense of the loss sustained. The Academy witnessed the beginning and the end of his long labours. It was to its halls he came as a student in 1859, and it was to them he paid his last visit before his final illness. The lustre thrown upon the Society by his researches is but a reflex of the spirit of this remarkable man who exhibited, in a way rarely equalled in the history of science, the consecration of a powerful intellect to the pursuit of the knowledge of nature. To an almost unerring accuracy of observation he conjoined admirable judgment. He was unexcelled as an expert in the field of vertebrate zoology of both present and extinct forms; he discovered great numbers of genera and species; he announced startling and epoch-making schemes of classification; he framed comprehensive systems of philosophy based on biologic premises."

**EDWARD JAMES STONE.**—There died at Oxford, from acute pneumonia, on Sunday, May 9th, Edward James Stone, the Director of the Radcliffe Observatory in that city. By a curious coincidence his death took place on the anniversary of the death of his predecessor, the Rev. R. Main, whom he succeeded in 1879. Mr. Stone was born in London in 1831. His more important astronomical appointments were as Chief Assistant at Greenwich in 1860. He became Her Majesty's Astronomer at Cape Town in 1870, whence he went to Oxford as above stated. Perhaps he is best known by his catalogues of stars of the southern hemisphere, one of which numbered 12,441 stars, published in 1881. Mr. Stone received the Gold Medal of the Royal Astronomical Society in 1868; Lalande Prize of the Paris Academy of Sciences in 1881. He was one of the Presidents of the Royal Astronomical Society and a member of the Council of the Royal Society. His work in organizing the observation of the Transit of Venus in 1882 was most successful, as he had previously observed a like phenomenon whilst at the Cape, with a seven-inch equatorial. His high reputation was attained by his accuracy in meridian observations, which faculty was largely developed at Greenwich under Sir George Airy. Mr. Stone was a member of Sir George Baden-Powell's expedition to Nova Zembla, in August of last year, where he, for a second time, had the opportunity of observing a total eclipse of the sun; the first having been in Namaqualand.

**JOHN M. DENTON.**—Canadian entomologists have lost two of their active workers. Mr. Denton was born in Northampton, England, on September 19th, 1829, and died March 24th last. Brought up in England as a tailor and draper, he emigrated about 1855 and settled in London, Ontario, where he gradually built up a successful business as a merchant tailor. During his leisure Mr. Denton cultivated a knowledge of economic entomology and fruit farming, and also microscopy. He was an original member of the London Branch of the Ontario Entomological Society, and served as one of its Vice-Presidents, and then President, in 1878, and several years following; he was also an active member of the Fruit Growers' Association.

**J. GAMBLE GEDDES.**—Captain Geddes was also an ardent entomologist, and wrote frequent articles in the "Canadian Entomologist." Born in Montreal in 1850, his early death, on April 3rd last, has caused much sympathy. He, in turn, served as Treasurer, Secretary, Vice-President and President of the Ontario Entomological Society. He was a bank manager by profession.

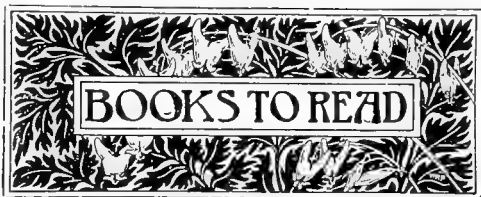

NOTICES BY JOHN T. CARRINGTON.

*The Young Beetle-Collector's Handbook.* By Dr. E. Hofman, with an introduction by W. Egmont Kirby, M.D. 178 pp. 8vo, illustrated by 20 coloured plates. (London: Swan Sonnenschein, New York: Macmillan and Co., 1897.) Price 4s. 6d.

If brightly-coloured pictures will help to induce young people to take up the study of the coleoptera, we should find a large accession to the numbers who take active interest in beetles. The collector, with the aid of this little work, will be able to make out without much difficulty at least the generic characteristics of most of the beetles he meets with, and so be led on to getting his specific identification elsewhere for the more obscure species. The work was originally published in Germany by Dr. Hofman, who is the curator of the Royal Natural History Museum at Stuttgart. It therefore contains figures of some species which are not counted as British. This is an advantage, as it will, we hope, lead the collector of our native species to broader lines of thought than used to be common among English entomologists. Those British species which are figured are clearly indicated in the text, so there need not be any confusion as to which are native or otherwise. Dr. Kirby's introduction is commendably short, and contains instructions for collecting and preservation. We should like to have seen a little more space devoted to suggestions for breeding these insects, whose life-histories are so little understood when compared with those of our butterflies, moths and saw-flies. The coleopterists have an immense field still open for such investigations, as the cycle of metamorphosis and individual habits of but few of our three thousand species have ever been worked out. Any field-naturalist taking up that branch of study has full opportunity of becoming celebrated. The plates contain upwards of 500 figures, and those of many of the larger species are excellent; but we fear, beyond getting an idea as to the generic character, many of the smaller are not much use for identification. This is almost certain to occur with coloured figures of the more obscure, because their differentiation depends upon structure rather than colour. As a whole we can recommend this work as being one which is likely to induce many to collect, and be to their assistance until they get past the stage of beginners' books.

*Entomological Society of Ontario. Twenty-seventh Annual Report, for 1896.* 127 pp. royal 8vo, illustrated by 103 figures. (Toronto: Ontario Department of Agriculture, 1897.)

The entomological societies of Canada are far in advance of those in this country, in so much as they get their publications issued at Government expense. This is a most fortunate thing, as it is the means of much information being circulated which could not otherwise be placed at the disposal of the public. The report now before us contains

a mass of information of all kinds relating to insects. One paper is devoted to "Some Insectivorous Mammals," with illustrations. Another, also illustrated, is on "Entomology for Rural Schools," and another on "The Importance of Entomological Studies to an Agricultural and Fruit-growing Community," which latter takes for its text: "The study of entomology is necessary, that the agriculturalists and fruit-growers may make the most of their insect friends." In fact, we can easily trace, in the great attention which is given by the Canadian entomologists to the economic aspect of their studies, the Government financial assistance which is so envied by our societies in this country. We hardly expect to find that their influence will gain such pecuniary aid, even in a small degree, from our county councils, while the whole attention of their members is devoted to species splitting and the nomenclature of Insecta. There are few countries where the economic side of entomology is more neglected by the ordinary collector than it is in Britain.

*The Flora of the Alps.* By ALFRED W. BENNETT, M.A., B.Sc., F.L.S., with 120 coloured illustrations. Vol. i., part 2. (London: John C. Nimmo, 1897.) Price 2s. 6d. net.

We fully noticed this handsome work in our last issue, and can only add that every one interested in wild flowers, either whilst travelling in mountainous Europe, or in growing them at home in Alpine gardens, should at once subscribe for this book. Part 2 contains thirteen coloured plates.

*British Game Birds and Wild Fowl.* By BEVERLEY R. MORRIS, M.D. Revised by W. B. TEGETMIER, F.Z.S. Illustrated by coloured plates. Vol. i., part 2. (London: John C. Nimmo, 1897.) Price 2s. 6d. net per part.

The second part of this work has reached us, and contains descriptions of black-grouse and red-grouse, with plates of the latter and ptarmigan. The re-issue of this work is a grand acquisition to the library of sportsman-naturalists. As stated last month, the work is to be completed in twelve parts.

*Journal of the Essex Technical Laboratories.* No. 26. April and May, 1897. 28 pp. 8vo, illustrated. (Chelmsford: County Technical Laboratories.) Price 3d.

The excellence of this publication is well maintained, and this number is full of useful information. We recommend many of our readers to subscribe for this serial as being of more than local interest.

*The Story of the Earth's Atmosphere.* By DOUGLAS ARCHIBALD, M.A. 208 pp. 16 mo, illustrated by 42 figs. (London: George Newnes, Limited, 1897.) Price 1s.

It has seldom been our pleasure to find so much information compressed, in most readable form, in so small a book. Mr. Archibald has the faculty for telling such a story as this in the most entertaining manner. The same in the hands of some men would have left the printers a mass of high and dry science, doubtless scrupulously correct, but unreadable by the multitude. We cannot too strongly recommend our readers to get this work; to most of them it will open new lines of thought, where food for it may be daily found surrounding them. The author's style is just what is wanted for this series—free, but not flippant, and impressive in his knowledge of the subject.

*The Royal Natural History.* Edited by RICHARD LYDDEKER, B.A., F.R.S. Illustrated by 72 coloured plates and 1,600 engravings. Second edition. (London and New York: Frederick Warne and Co., 1896-97.) In 72 weekly numbers, price 6d. each.

This new edition of the *Royal Natural History* is indeed a wonderful instance of modern cheap publishing. Each number contains forty-eight pages of letterpress, many engravings, and a coloured plate. In this edition new coloured plates have been added in some instances, such as for tigers, leopards, etc. The letterpress has been revised and brought quite up to date by the editor as published. The work has reached its fifty-second

a short general introduction to entomology, and directions for identifying, prevention and eradication of the pests. There are also some life-histories and many excellent illustrations. There is a short appendix containing several animals of allied classes to insects, such as mites and centipedes. The arrangement in treating with the subject is to select the order of plants likely to be attacked, and then to describe the insects to be expected.

*The Naturalists' Directory*, 1897. 102 pp. 8vo. (London: L. Upcott Gill, 1897.) Price 1s.

This is the third edition of what in time will doubtless become a useful and important work for naturalists. The present issue is decidedly improved

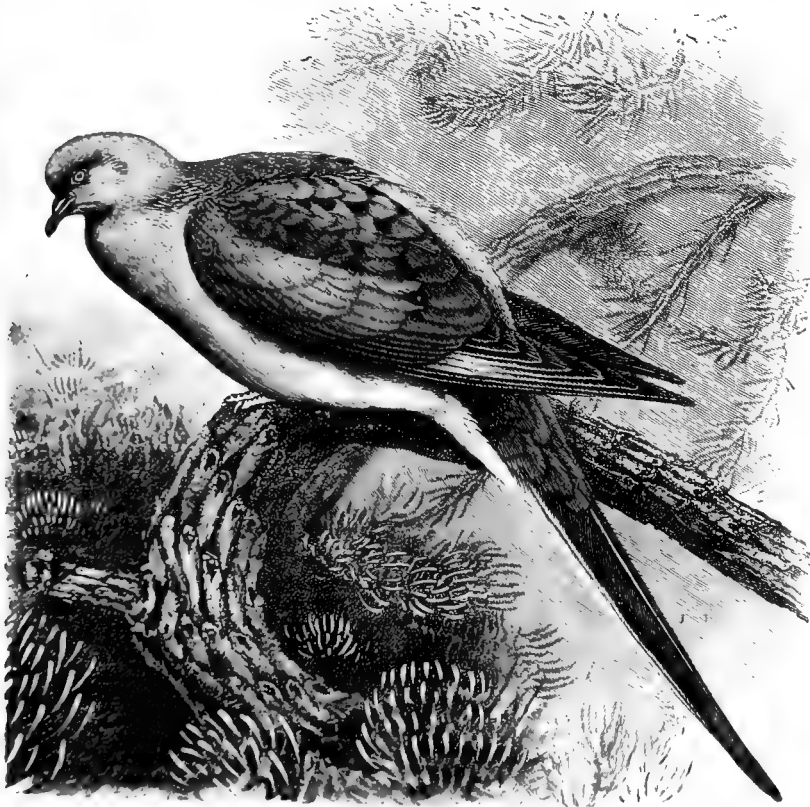

PASSENGER PIGEON.

From Warne's "*Royal Natural History*."

part. It contains all that appeared in the first edition, with some extra features. When complete the book binds up into six handsome volumes

*Farm and Garden Insects.* By WILLIAM SOMERVILLE, D.Sc., F.R.S.E., F.L.S. 125 pp. 18 mo, illustrated by 46 drawings. (London and New York: Macmillan and Co., Ltd., 1897.) Price 1s.

This little work will be found useful to many who live in the country, or are cultivators of suburban gardens. For those who desire to do good by educating rural workers to a better knowledge of insect pests, it affords an opportunity for giving a useful but inexpensive aid to the attainment of such information. Its pages contain

in many ways, and far more complete than the last. There is, however, still much to be added to a new edition, especially in regard to finding out those very numerous silent workers who do so much but are rarely heard of. The work is now well worth its price, but we predict that it will have to be largely augmented before the directory becomes anything approaching perfection.

Messrs. Ross and Co., 111, New Bond Street, London, have sent illustrated catalogues of new instruments, including the Photoscope, and a pamphlet on "The Electric Arc Light" for lantern projection, by Mr. Cecil M. Hepworth, which contains description of the Ross-Hepworth arc lamps and the new patent eccentric carbon.



CONTRIBUTED BY FLORA WINSTONE.

ANNALI DEL MUSEO CIVICO DI STORIA NATURALE DI GENOVA (Genoa, 1897).—The English articles in this number are chiefly devoted to collections that have lately been made in Somaliland. Mr. G. A. Boulenger, F.R.S., writes on the "Reptiles and Batrachians collected by the late Prince Eugenio Ruspoli in Somaliland and Gallaland in 1893." He also gives a "Report on Captain Bottego's Second Collection of Reptiles and Batrachians from Somaliland." This collection, which was given into his care by Marquis G. Doria, President of the Italian Geographical Society, consists of 247 specimens referable to fifty-six species, all of which have been previously described. The specimens were collected between Brava and the confluence of the Web and Ganana, in Southern Somaliland. Mr. Boulenger gives notes on several species which are little known, and adds some synonymic rectifications. M. D. Vinciguerra and M. F. Silvestri also contribute articles on collections made by Prince Ruspoli in Somaliland. M. Ch. Kerremans, M. Carlo Emery, and Mr. Thomas Oldfield have further notes on Captain Bottego's collections from the same country, Mr. Oldfield's being on the mammals obtained. A full account of Prince Ruspoli's expedition and collections have already been published in the "Bollettino della Società Geografica Italiana," 1895. M. E. André has a long article entitled "Étude sur les Mutillides existant dans les Collections du Musée Civique de Gènes." He writes exclusively of the Mutillides of India and Australia, which are better represented in the Museum at Genoa than those of any other country; besides is a list with ample notes of each species, including twelve that are new. M. André gives a synoptical table of the species he has mentioned or described. He also adds an appendix descriptive of some Mutillides which lately arrived at the Genoa Museum, they were captured and presented by Lieutenant F. Derchi, from Erythrea. Mr. Martin Jacoby gives a "List and Descriptions of the Phytophagous Coleoptera obtained by Dr. Modigliani from Mentawai Islands." Amongst the Phytophagous Coleoptera obtained by Dr. Modigliani from the islands south of Sumatra are some which seem to be new, and Mr. Jacoby says are probably peculiar to Mentawai. They belong chiefly to Galerucinae and Halticinae. Mr. Jacoby mentions that he knows of no previously described insects from these islands. Professor J. Thorell contributes an article on the explorations of Leonardo Fea in Burma and the surrounding regions. This is the second of a series, the first having been devoted to the spiders of Burma. The present article is on the sub-order Paralleodontes of Araneae, collected by M. Leonardo Fea. Many new species are mentioned and described. M. Leonardo Fea himself contributes a long and well-illustrated article on the "Zoology of Burma and Neighbourhood."

LA FEUILLE DES JEUNES NATURALISTES (Paris, May, 1897).—M. Etienne Rebaud contributes an article on "Cellular Division," illustrated with eleven figures showing the development of cells. M. Henri Hua writes on the underground life of *Convallaria majalis*, with five figures illustrating various forms. The series of articles on the French shore of the Channel by M. Adrian Dolfus are continued in this number, with a page of photographs of species of *Cardium*, *Tapes pullastru* and *Donax vittatus*. M. G. de Rocquigny-Adanson contributes an article on the geographical distribution of the large moth, *Saturnia pyri*. After a year of enquiry and research M. de Rocquigny-Adanson has obtained the results which he publishes, with a map showing the distribution of this moth in France. It is never found in the North of France, and the lines which limits its northern distribution are between the 48th and 50th degrees of latitude.

"PROCEEDINGS OF THE ACADEMY OF NATURAL SCIENCES OF PHILADELPHIA" (February and March, 1897).—Among a number of valuable papers are "New Fossilorial Hymenoptera from New Mexico," by T. D. A. Cockerell and William J. Fox; "Demonstration of the use of Oxygen by Diatoms," by T. Chalkley Palmer, and one of importance on "Meadow-larks of Northern America," by Witmer Stone.

ANNAES DE SCIENCIAS NATURAES (Oporto, January, 1897).—In this number are papers by Dr. L. Vieira, on "The Reptiles of Portugal"; Mr. W. C. Tait, on "Birds of Portugal"; Sig. Augusto Nobre, continuation of "The Molluscs of Portugal," etc.

The French Government has awarded 4,000 fs. to Dr. P. Gréhan, Professor of Physiology in the Paris Museum of Natural History, to promote his researches on the application of physiology to hygiene.

PROFESSOR KARPINSKI—The Committee on the Hayden Geological Memorial Award, which is managed by the Philadelphia Academy of Sciences, has conferred the medal and interest on the fund for 1897 on Professor A. Karpinski, of St. Petersburg, Director of the Geological Survey of Russia. Professor Karpinski has long been the most prominent figure among Russian geologists, and, in spite of the claims upon his time and energy of the geological survey of Russia's gigantic domain—very far the largest region in the world under the direction of a single man—he has found time to contribute valuable additions to our knowledge in many different fields. Some of these are: "Geological Investigations and Exploration of the Coal Deposits of the Eastern Urals," 1880; "Remarks on the Sedimentary Formation of Russia-in-Europe"; "Origin of the Iron Ore in the Donety Basin"; "Geographical Observations on the Urals"; "Sedimentary Beds of the Tertiary of the Eastern Urals"; "Reference to the Occurrence of Permo-Carbonic Measures in Darwaz-minca," 1884; "Ammonites from the Ural," 1884; "Fossil Pteropods," 1884; "Essay on Unification, etc.," 1884; Geological Map of the Urals, 1884; "Materials for the Study of the Methods of Petrographic Research," 1885; Geological Map of Russia, Sheet 139; "Orographic Description," 1886. Professor Karpinski has been prominent in the councils of the International Geological Congress, his ability and eminence suggesting his selection as the President of the general committee of organization of the coming Congress.

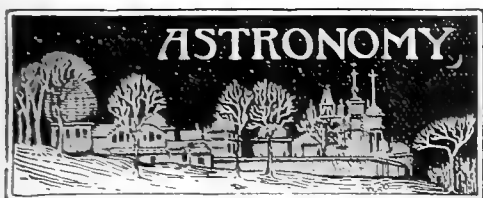

CONDUCTED BY FRANK C. DENNETT.

	June.	Rises.		Sets.		Position at Noon.	
		h.m.	a.m.	h.m.	p.m.	R.A. h.m.	Dec.
Sun	6	3:47	4:59	8:10	4:59	22° 43' N.	
	16	3:44	5:41	8:17	5:41	23° 23'	
	26	3:46	6:22	8:19	6:22	23° 21'	
		Rises.		Sets.		Position at Noon.	
		Souths.	Semis.	Souths.	Semis.	R.A. h.m.	Dec.
Moon	6	9:34 a.m.	4:51 p.m.	11:50 p.m.	4:56 a.m.		
	1	10:11 p.m.	1:12 a.m.	5:53 p.m.			
	11	0:41 a.m.	9:0				
		Souths.		Semis.		Position at Noon.	
		h.m.	Diameter.	h.m.	Dec.	R.A. h.m.	Dec.
Mercury	6	1:40 a.m.	5' 0	3:40	15° 25' N.		
	16	1:25	4' 0	4:5	17° 21'		
	26	1:28	3' 2	4:58	20° 55'		
Venus	6	1:16	1' 2	2:16	11° 19' N.		
	16	1:2	1' 0	2:42	12° 37'		
	26	1:24	1' 0	3:14	14° 32'		
Mars	6	7:54 p.m.	2' 3	8:55	18° 52' N.		
	16	7:58	2' 2	9:19	17° 4'		
	26	8:22	2' 2	9:42	15° 7'		
Jupiter	6	4:44	1' 5' 9	10:25	11° 8' N.		
Saturn	16	9:53	8' 5	15:35	16° 58' S.		
Uranus	16	9:52	1' 9	15:34	19° 48' S.		
Neptune	6	15	1' 2	5:16	21° 44' N.		

MOON'S PHASES.

	h.m.	h.m.
1st Qr.	June 8 ... 7.2 a.m.	Full ... June 14 ... 9.1 p.m.
3rd Qr.	" 21 ... 11.24 p.m.	New ... " 30 ... 2.55 a.m.

In perigee, or nearest the earth, the distance being only 223,400 miles, on June 13th, 4 p.m. When farthest from the earth, or in apogee, on 25th, at 10 p.m., the distance will be 252,100 miles.

OCCULTATIONS.—June 14th, the variable star X<sup>s</sup> Saggiarii, 4th- to 6th-magnitude, will disappear at 11.14 p.m. 105° from the vertex, the highest point of the moon's limb above the horizon. The angle is reckoned towards the east, and continued up to 360°. The star re-appears at 0.27 a.m. on 15th, 257° from vertex.

June 16th, σ Saggiarii, 2.3 magnitude, disappears at 0.0 a.m., 140° from vertex, and re-appears at 0.47 a.m., 212° from vertex.

\* Printed in error X in our May number (vol. liii., p. 337), by my oversight.

CONJUNCTIONS OF PLANETS WITH THE MOON:

June 5	Mars	11 a.m.	planet 1° 19' N.
7	Jupiter	7 a.m.	" 2' 4' N.
11	Saturn	9 a.m.	" 2' 15' N.
26	Venus	9 a.m.	" 8° 38' S.
27	Mercury	1 p.m.	" 5' 11' S.

Daylight. † Below horizon in England.

SUN—Spots of considerable size occasionally make their appearance. No spots were noted with a small instrument from April 22nd to 28th, but on the next day a large spot had come round the limb, and some tiny pores appeared a little north of the middle of the disc.

MERCURY may be observed in the early morning in the middle of the month, reaching its greatest elongation west, 22° 48' at 6 a.m., on June 16th, when it rises some 55 minutes before the sun. It was readily seen that time after sunset, even in smoky London, on May 3rd, by the writer without optical aid. It is unfortunate that on 29th it will be bright daylight when Mercury is in conjunction

with Neptune, only 13'—less than half the diameter of the moon—separating the two planets.

VENUS may be observed as a morning star all the month, rising 1h. 25m. before the sun on June 1st, and 2h. 21m. before sunrise on June 30th. It reaches the greatest brilliancy about midnight on June 3rd. Her path lies in a very barren region of the constellations Aries and Taurus.

MARS sets just after midnight on 1st and about 10.34 on June 30th, but he only presents a very tiny disc.

JUPITER is fast sinking towards the west, setting about half-an-hour after midnight at the beginning of the month, and just before eleven at the end. His surface, however, presents a noble sight, even with comparatively small instruments.

SATURN is in good position all the month, and presents a splendid sight. On June 14th the major axis of his outer ring subtends an angle of 42' 57"; whilst the minor axis is 17' 08", just greater than the diameter of Saturn. At 8 p.m. on 18th, Saturn is in conjunction with Uranus, which is situated 2° 3' to the south. Saturn is in Libra, not far from the 4th-magnitude star η.

URANUS is in good position, but suffers even more than Saturn from its great south declination.

NEPTUNE being in conjunction with the sun at 5 p.m. on 10th, is quite out of the reach of the observer.

METEORS should be specially looked for on June 6th and 7th, but also about 22nd, 29th and 30th.

RED STARS are some of the most remarkable objects in the star depths. They vary in colour from a reddish tint to a deep blood-red. Many of them are variable in magnitude, and some in colour. They present, too, a spectrum peculiar to themselves, the dark lines being grouped in such a manner as to present the appearance of what is known as being fluted. The spectroscope fitted to a telescope so small as three inches aperture will show this. We will reserve until next month our first list of these objects.

THE NOVEMBER METEORS.—In April, 1867, the late Professor J. C. Adams' paper, "On the Orbit of the November Meteors" was published, and had become scarce; but the Royal Astronomical Society have just re-issued it in their Monthly Notices for March. It should prove welcome in view of the expected return of the Leonids in about three years.

DR. KARL BOHLIN, of Upsala, succeeds the late Professor Gylden as Astronomer to the Royal Academy of Sciences at Stockholm, and Director of the Observatory.

ROTATION PERIOD OF VENUS, was the subject which took up a great part of the time at the last meeting of the British Astronomical Society, at Essex Hall, Strand, W.C., which may probably prove the new quarters for the meetings of that society. The satisfactory proof of the true rotation period is seemingly very slow in being worked out.

THE NEW OBSERVATORY FOR LONDON. Progress seems to have been made with this institution, for at the meeting above referred to it was announced that the Director of the Solar Section, Miss Brown, had given £50 towards the expenses, whilst the President, Mr. Nathaniel E. Green, had offered his eighteen-inch silver-on-glass reflecting telescope towards its equipment, and Mr. George Calver had offered optical aid.





THE Canadian Electrical Association will meet on June 2nd, 3rd and 4th, at Niagara Falls, Ontario.

AN exhibition of Agriculture and Forestry will be held in Vienna by the Imperial and Royal Agricultural Society, from May 7th to October 9th, 1898.

THE Zoological Society of Germany will hold its seventh annual congress, at Kiel, from the 9th to the 14th of June, under the presidency of Herr Büttschi, of Heidelberg.

M. LOUIS LÉGER has recently contributed to "Comptes Rendus" some important particulars of certain Coccides living with Arthropoda, and describes several new species.

THE Botanical Section of the St. Petersburg Society of Naturalists propose to publish a full herbarium of the flora of European Russia, similar to the "Herbarium Normale" by Fries.

IN "Science," April 30th, Mr. F. A. Bather, of the British Museum (Nat. Hist.) replies to a review, by Mr. F. A. Lucas, of his paper, "How may Museums best Retard the Advance of Science."

THE Cork Naturalists' Field Club seems to grow steadily, and is evidently popularising a taste for natural science in its district. The annual report shows much vitality and useful work accomplished.

THE past winter seems to have been, in the south of England, one of the wettest on record. At Croydon the annual average was reached during the seven and a-half months following September 1st last.

IT was decided by the Budget Commission of the French Government that the sum of four thousand pounds should be voted for the Pasteur Institute at Rhia-Trang to encourage Dr. Yersin's researches on the plague serum.

PRINCETON University will send its fourteenth geological expedition to the West during the coming summer. The party, under the direction of Professor Scott, will make palæontological and geological studies and collections in South Dakota.

PROFESSOR LAWRENCE BRUNER, of the Nebraska University, sailed for Buenos Ayres on April 27th. He purposes to spend a year investigating the injurious locusts which have recently increased enormously in three of the eastern provinces of the Argentine Republic.

IN the "Proceedings" of the Royal Irish Academy, 3rd series, vol. iv., No. 1, Mr. D. M'Ardle describes the Hepaticæ of the Hill of Howth. His list of species includes no less than fourteen liverworts not previously noted in the County of Dublin, two being new to Ireland.

M. O. POMÉL has found in Algiers, in strata of the quaternary period, the remains of a bear (*Ursus libycus*); a hyena (*Hyæna spelæa*), probably identical with the hyena of the caves of Europe; two cats, *Felis spelæa* and *F. antiqua*; a jackal (*Canis aureus*), resembling a common jackal, and several domestic dogs.

WE are pleased to welcome a new quarterly journal of which a couple of numbers have been published under the title of the "Aeronautical Journal." It is the official organ of the Aeronautical Society of Great Britain. It is brightly edited and illustrated. The two numbers contain much of interest to aeronauts and others.

DR. THOMAS P. LUCAS, in a paper on the flying-foxes of Queensland, read before the Royal Society of that Colony in June last, reminds us that the flesh of these bat-like animals is "good gamely food." He further suggests that the gastric juices of their stomachs might be utilized to assist human digestion, after the manner of pepsin.

MR. GEORGE H. CARPENTER, B.Sc., the Director of the Natural History Department in the Science and Art Museum in Dublin, has caused extensive re-arrangements of the collections to be made. The effect will be a great improvement, especially as it will provide for the new Irish collection formed to show the present fauna of the country. This should be of great value to students.

A NEW entomological society has been formed in the City of Quebec. At present it is affiliated as a branch to the Ontario Society. With such an ardent entomologist as the Rev. T. W. Fyles, F.L.S., as president and organiser, we predict its early secession, and would congratulate the members on independence; considering the size of the province the new society will have to work.

MONS. A. SUCHETET, of Chateau D'Antville Bréauté, Seine-Inférieure, has long been studying hybrids between various animals. He recently published a volume on such cases among mammals, and is now collecting material of a like character among insects, fishes and reptiles. M. Suchetet would highly value particulars of trustworthy cases. He may be addressed in either French or English.

CANADA is much exercised in spirit over a source of her mineral wealth. In Ontario are vast deposits of nickel ore. A Government commission of experts from the United States some time ago was sent to examine the districts where it occurs, which are in the neighbourhood of Sudbury. The commission reported an estimate of 650,000,000 tons of nickel ore in sight. This, coupled with the fact of the comparatively new use of nickel-steel for guns and armour plates, has awakened great attention and some alarm. It seems possible that the intention was to get private control of these valuable mines in order to supply European powers with the material.

BALLOONING in the Polar regions is to be again attempted this season, and by more than one expedition. The Andrée party start immediately, with an increased lifting power, many square feet of extra gas accommodation having been provided in the balloon. A French expedition has also been arranged by M. Louis Godard, under the auspices of four Parisian journals. A committee of superintendence has been formed with M. Rambaud, the Minister of Public Instruction, as president; it also includes five members of the Académie des Sciences. The balloon is to carry seven persons. When in sailing order this machine will have to lift something like 25,000 lbs. weight, including itself. It is estimated the balloon will, when ready, be able to float from forty to sixty days. This expedition, like that of M. Andrée, will make Spitzbergen the base of operations.



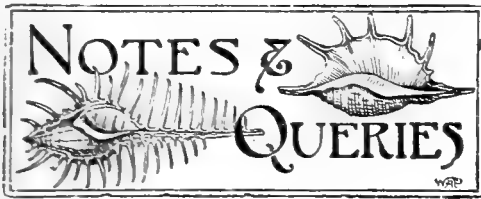

**FORAMINIFERA IN LONDON CLAY.**—Could any of the readers of SCIENCE-GOSSIP inform me whether foraminifera or diatoms have been found in the London clay now being taken out of the tunnel of the Central London Railway. I have found only crystals. I find they are plentiful under Piccadilly.—A. Henley, 303, Strand, London, W.C.

**BIRD-SONG IN DURHAM.**—There is a remarkable absence of bird-song this season in our part of Durham. The birds, especially song-thrushes and blackbirds, are almost absent in Twizell Dean and in Pit-Hill Plantation, where they used to be common enough. This seems to be the result of the ruthless killing off of everything alive in our district.—John Rouell, Twizell Colliery Durham. The absence of these birds is evidently local, because we never remember more wild birds than are now to be seen in almost every part of this country.—ED. SCIENCE-GOSSIP.]

**ORCHIDACEÆ IN SURREY.**—During a ramble on the chalk hills, south of Horsley, in Surrey, on the 23rd May, a small party, including several field-botanist, found the following orchidaceous plants just coming into flower: green-winged meadow-orchis (*Orchis morio*), early purple orchis (*O. mascula*), spotted-palmate orchis (*O. maculata*), great-butterfly orchis (*Habenaria chlorantha*), bee orchis (*Ophrys apifera*), green-man orchis (*Acycos anthrophophora*), bird's-nest orchis (*Neottia nidus-avis*), tway-blade (*Listera ovata*), and heleborine (*Cephalanthera grandiflora*). The season could not be described as at all forward, although some spring plants were well over their flowering stage, while others, which usually appear about the same time, were still in full bloom.

**NEW FELLOWS OF THE ROYAL SOCIETY.**—The following have been selected by the Council for election: Robert Bell, M.D., B.Sc., LL.D., Assistant Director of Geological Survey of Canada; Sir Wm Hy. Broadbent, F.R.C.P., Physician to H R H the Prince of Wales; Chas. Chree, D.Sc., M.A., Superintendent of Kew Observatory; Hy. John Elwes, F.L.S., F.Z.S., President of the Entomological Society in 1893-4, and Ornithologist; John Scott Haldane, M.D., Lecturer in Physiology, Oxford; Wm A. Haswell, M.A., D.Sc., Vice-President of Linnean Society of New South Wales; George Bond Howes, F.L.S., Assistant Professor of Zoology in Royal College of Science, London; F Stanley Kipping, Lecturer in Chemical Department of City and Guilds of London Institute; Geo. Ballard Mathews, Professor of Mathematics in University College of New South Wales; Geo. Robert Milne Murray, F.L.S., F.R.S.E., Department of Botany, British Museum; Francis Henry Neville, M.A., Lecturer in Natural Science, Sydney College; H Alleyne Nicholson, M.D., Regius Professor of Natural History, Aberdeen University; John Millar Thompson, F.R.S.E., F.I.C., Secretary of Chemical Society; Fred Thos Trouton, D.Sc., M.A., Assistant Professor Natural Philosophy in Dublin University; Herbert Hall Turner, M.A., D.Sc., Secretary Royal Astronomical Society.

**FOSTER-PARENTS OF CUCKOO.**—I have just received information from Dr. E. Rey, of Leipzig, that another foster-parent of the cuckoo has been discovered. He says, on May 14th, 1895, in Lebuja, Sevilla, Spain, a nest of *Cyanopica cooki* (the azure-winged magpie) was taken containing five eggs, with one of *Cuculus canorus* (cuckoo). Eggs of the great spotted cuckoo have on various occasions been found in nests of this species. This addition to my list published in the "Transactions" of the North Staffordshire Field Club, 1896, brings the number of recorded foster-parents of the cuckoo to 146.—W. Wells Bladen, Stone, Staffs; April 24th, 1897.

**ABNORMAL PRIMROSE.**—I enclose a sketch of an abnormal form of *Primula veris*, which I have not noticed before. The plant from which the flower was taken is growing in a garden at Desborough, Northamptonshire. It was brought last year out of one of the neighbouring fields, and there was, apparently, nothing unusual in the form of the flowers, but this year they show a decided tendency to sport in the direction of the specimen shown, though some of the flowers are normal. It will be seen that the petals are surrounded by a whorl of five leaves, which reproduce the form of the normal leaves, but are much reduced in size; the calyx is wanting. In the specimen figured there were only three stamens, and the form of the stigma was flat and leaf-like. I shall be glad to know whether any of your readers have observed a similar form.—G. Creswell Turner, Parkhurst, Upper New Walk, Leicester; April 24th, 1897.

**VARIETIES OF BRITISH BUTTERFLIES.**—It may be well to call attention to the varietal nomenclature in Mr. Tutt's recent work, "British Butterflies." Although Mr. Tutt's knowledge of the literature of his subject is admittedly great, he has, on this occasion, re-named several varieties (or mutations) and omitted several others. *Cænonympha pamphilus* ab. *pallida*, Tutt, seems to be the *albescens* of Robson and Gardner, 1885. *Polygonia c-album* ab. *pallida*, Tutt, appears to be *hutchinsoni*, as has been pointed out elsewhere. *Polyommatus corydon* ab. *minor*, Tutt (as new) is *minor*, Ckll., Entom., July, 1889. *Colias edusa* ab. *obsoleta*, Tutt, is *pseudomas*, Ckll., Entom., February, 1889. *Colias hyale* ab. *pallida*, Tutt, is not the form *pallida*, Robson and Gardner, 1885, so it will need to be re-named. It may be as well to remark that the "very probable explanation" on p. 235, respecting *Pieris protodica* and *P. rapa* in America, is a pure product of someone's fertile imagination; the two insects are entirely different, and are placed by Scudder in different genera.—T. D. A. Cockerell, Mesilla, New Mexico, U.S.A.; April, 1897.

**MANGANESE DEPOSITS.**—Last summer I came across a bed of impure manganese oxide in a gravel deposit at Harpenden, exactly similar to that described by Dr. Lones at Watford (SCIENCE-GOSSIP, vol. iii, p. 322). This is some miles to the north of the area he mentions. I was rather puzzled as to its origin, and was glad to see the suggestion made in the paper. The object of this note is to ask Dr. Lones whether the stratified gravel at Harpenden, which now forms the floor of the dry valley running nearly due south through the village, and seems to merge into the more extensive spread on "No Man's Land" near St Albans, had a similar origin to his Watford gravels? I have generally considered that the former was formed by the denudation of tertiary beds, and deposited along a river which once flowed down

this valley. Outliers of Woolwich and Reading beds are left in places on the flanks of the valley. The only erratics I have found here were pale-coloured grits or quartzites more like the grey-wethers of the south than the quartzites of the northern drift. I should also like to ask whether the deposit of boulder-clay, near Bricket Wood, contains erratics from the Nuneaton district, or whether they have not come from a north-east direction? I have seen it mentioned that beds of manganese ore occur in the Bure Valley in Norfolk.—*N. E. McIntire, 6, Linden Road, Bedford.*

**ABNORMAL ORANGES.**—I see that you have some notes and an inquiry with regard to what your correspondent thinks to be an abnormal form of orange. (Vol. iii., pp. 307, 341.) This can scarcely now be termed a sport, as it is grown by the million in California, and has been a common form on all the markets of this country for years under the name of "navel" orange, so termed from the resemblance of the end to the umbilicus. I do not know the method of its production, but it is an example of a successful effort to produce a seedless fruit. The fruit-growers of California claim that they will be able in course of time to produce seedless grapes and other things. That State is, I believe, the only place where this orange is grown, though it first made an appearance at Florida, but the frost of a few years ago unfortunately did so much damage to this variety of orange-trees that there has been very little fruit from that State since. I think I saw a paragraph in the papers some time back saying that grafts of this orange had been introduced in Europe. The fruit is a very fine one. I have seen specimens on the market here fully eight inches in diameter, and I am somewhat surprised that it is still looked on as a curiosity in England. California oranges have much improved in the past few years; and this winter there were sent to market quite a number of cases of blood-oranges finer than those imported from the Mediterranean.—*H. E. Smith, Chicago; April 29th, 1897.*

**SELBORNE SOCIETY FIELD CLUB.**—The first summer gathering of the Croydon Selborne Society took place on Saturday, May 8th, when the members met for an afternoon ramble at Sanderstead station. The route taken was by Sanderstead Church, along the Upper Warlingham Road, and across the fields to Riddlesdown and Kenley. The weather was all that could be desired. Many spring flowers were found to be still in blossom, the lesser celandine (*Ranunculus ficaria*) being still met with, whilst primroses (*Primula vulgaris*) were very plentiful. Wild hyacinths (*Agaphis nutans*) were at their best, a few white specimens being found. A few early bugles (*Ajuga reptans*) were in blossom, but the arum (*Arum maculatum*) had not yet opened their spadix or hood. The creepers have not yet reached the hedges, but the discovery of the early purple orchis (*Orchis mascula*) rewarded some of the party. Portuguese laurel and holly were in blossom, but the hawthorn was not yet out. Nightingales were repeatedly heard singing, as well as our spring visitors, the cuckoos. A few partridges were seen. Entomologists bottled water-fleas and the pupæ of gnats, which exist in a wingless stage beneath the water. On Riddlesdown fossil sponge-remains (*Ventriculites*) were found in flints, and growing amongst the grass were seen early specimens of milkwort, both blue and white (*Polygala vulgaris*). The members of the Lambeth Field Club joined the society on this occasion.—*Edward A. Martin, Hon. Sec.*



**ROYAL METEOROLOGICAL SOCIETY.**—The monthly meeting of this Society was held on Wednesday afternoon, the 19th inst., at the rooms of the Royal Astronomical Society, Burlington House, Mr. E. Mawley, F.R.H.S. President, in the chair. Mr. F. Gaster, of the Meteorological Office, read a paper, by himself and Mr. R. H. Scott, F.R.S., on "The Mean Monthly Temperatures of the British Isles." The authors dealt with the means of the daily minimum, average and maximum temperatures for the various months of the year in the twenty-five years of 1871-1895. They pointed out that there is a great difference between the amount of range of temperature at the coast stations and that recorded inland. The range between January and July amounts to about sixteen degrees at coast stations, but to more than twenty-three degrees at the inland stations. The contrast between the temperature of the air at inland and at coast stations at different times of the year is due to the following causes: (1) the constant tendency of the sun to heat the surface of the earth; (2) the equally constant tendency of the earth to radiate its heat into space—both of these being modified greatly by the aqueous vapour and the clouds suspended in the atmosphere; (3) the fact that the solid portions of the earth absorb and reflect heat much more rapidly than the water; and (4) that while the ocean to the westward is of enormous size and great depth, the sea to the eastward is, comparatively speaking, limited in area and shallow, and separates the eastern shores of the British Islands from those of continental Europe by a small distance. A paper by Mr. C. V. Bellamy on "The Rainfall of Dominica, West Indies," was also read. The author gave an interesting account of the climate of the island, and then discussed the monthly returns of rainfall from twenty-seven stations during the four years 1893-6. The rainy season extends from July to November, the other months representing the dry season. The month of November, 1896, was the wettest on record.

**SOUTH LONDON ENTOMOLOGICAL AND NATURAL HISTORY SOCIETY.**—April 8th, 1897. Mr. R. Adkin, F.E.S., President, in the Chair. Mr. South exhibited the following Geometridæ from Europe and Eastern Asia. *Eustroma reticulata* and var. *erosa*, the latter larger and more golden yellow than the type; *Cidaria silacea*, Chinese specimens, both larger and smaller than European; *C. corylata*, Eastern examples, very similar; *C. picata*, some Chinese specimens, larger and more yellow; *Melanippe procellata*, some were larger than European and some with ground-colour suffused with a fuliginous shade. Mr. Lucas, specimens of an exotic earwig, *Amisolabis annulipes*, which could be distinguished from British species by two white joints near the tip of the antennæ; the distinctly ringed femora gives it its specific name; it was found in 1894, at Tavistock, but the specimens exhibited came from Surrey. Mr. Adkin, a fine series of red forms of *Tæniocampa gracilis* from the New Forest

and Rannoch. Mr. Tutt read a most interesting paper, entitled "Some Considerations of Natural Genera and Incidental References to the Nature of Species."—April 22nd. Mr. R. Adkin, F.E.S., President, in the chair. Mr. Malcolm Burr, Bellagio, East Grinstead, Sussex, was elected a member. Mr. Waters exhibited a number of the "casts" of both owls and rooks. These *rejectiona* were examined, and the former contained bones, starlings' skulls, etc., while the latter contained corn-husks and beetles' wings mainly. Mr. Barrett, the only known Scottish specimen of *Colias hyale*, captured in Dumbartonshire by Mr. Mallock. He also exhibited a variety of *Crymodes exulis*, taken by Mr. Percy Bright in Unst, a form at one time considered a distinct species and termed *Hadena mailardi*, together with the same species from Rannoch and Iceland. Mr. Auld, a varied series of *Cucullia chamomillæ* from Lewes. Mr. Robt. Adkin, a series of *Hybernia marginaria* (*frogemmaria*), the progeny of a pair received from Mr. Hewett, of York; about sixty per cent. of the males were of the black form and followed the parents, while the whole of the females were dark. He also made remarks upon the scaling and pigmentation. Mr. Mera, a larva of *Callimorpha hera*, which had fed all the winter and was in its last stage. Mr. Perks, a specimen of morel (*Morchella esculenta*), which fungus came from an iron-yard in Greenwich. Mr. Step, the following specimens of spider crabs from Portscatho: *Macropodia rostratus*, male and female, with a card of dissections to show sexual differences, curved hooked hairs, upper and under sides of the chelæ, etc.; *Inachus dorycnus* and *I. leptochirus*; *Pisa tribulus*, with a red sponge covering the whole of the carapace; and photographs of *Maia squinado*. The Secretary then read a paper on the above exhibit communicated by Mr. Step, entitled "Some British Spider Crabs."—May 13th. Mr. R. South, F.E.S., Vice-President, in the chair. Mr. Stanley Edwards exhibited a small scorpion, which he had captured at Digne, in the South of France, together with a specimen of the field cricket from the same locality. He also exhibited a pupa of *Charaxes jasius*, and stated that Dr. Chapman had sent him larvæ of this species from Cannes, earlier in the year. Mr. Tutt made remarks upon the condition of vegetation and insect life as observed by Mr. Edwards and himself during a week's holiday at Easter in the south-east of France. The weather there was superb, but yet the vegetation there was, at 1,900 feet above the sea, but little in advance of that in the south of England. With the development of insect life there was no comparison, for in one day he had seen no less than fifty-two species of lepidoptera. In the corner of one field were to be seen all our three species of the genus *Melitæa*, flying together. Mr. Edwards exhibited, on behalf of Mr. Lamb of Maidstone, specimens of the flowers of *Ophrys aranifera* (spider orchis), *Orchis purpurea*, *Smyrnum olusatrum* and of the whortleberry, all from that district. Mr. Lucas exhibited a mature and two immature specimens of an Indian species of cockroach (*Leucophaea surinamensis-indica*), taken in the forcing-pits at Kew Gardens. Mr. Montgomery, young larvæ of *Afamea ophiogramma* in the stems of the ribbon-grass, and contributed notes on its habit of leaving its old burrow and selecting a new stem. Mr. South, a series of *Amphidays strataria* (*frudi-maria*), and remarked on their small size, while the larva had been unusually large. Mr. Auld, a varied series of *Boarmia*

*cinctaria*, taken this year in the New Forest. Mr. H. Moore, specimens of the rare insect, *Pseudopontia faradaxa*, with drawings showing its anomalous venation, its bifid scales and the isolated position of each scale on the wing-membrane. He contributed notes on the species which he said had come from Mombasa, East Africa, and about the position of which insect there was the widest divergence of opinion; some authorities placed it with the Rhopalocera, some among the Geometers and some among the Bombyces. Mr. Clark, a series of photographs of sections of the stems of various trees and plants. Mr. Turner, on behalf of Mr. Clarke, of Reading, specimens of *Tephrosia crepuscularia*, taken in the wood, which Mrs. Bazett had said did not produce the species. Mr. Tutt read a paper, sent by Professor Grote, A.M., entitled "Autumnal Notes from the Butterfly Camp by the Shores of Lake Erie."—Hy. J. Turner, Hon. Report. Sec.

NORTH LONDON NATURAL HISTORY SOCIETY.—February 11th, 1897. Mr. C. Nicholson, President, in the chair. Exhibits: Mr. Prout, bred specimens of *Eupithecia castigata*, from Sandown, and *E. jasonata*, from North Devon. Mr. Bacot, larvæ of *Bombix quercus* (received from Mr. Goymour), and of *B. spartii* and *B. quercus* from South France (received from Mr. Warburg), on which he read notes. Mr. Battley, thirty-eight species of Pyralides. Mr. Woodward also exhibited. Mr. Dadd remarked that all the female *Arctia plantaginis* which he had taken in Germany had red hind-wings instead of the ordinary yellow tint. Mr. L. J. Tremayne opened a discussion on "Over-collecting and its Remedies." This question, he said, had been before the public some time, and though over-collecting might not be responsible for so much injury to species as some supposed, there was no doubt that it did exist and did a great deal of harm. It was very difficult to know how to stop it, principally on account of the differences of opinion as to the proper remedy. The three main remedies seemed to be boycotting, legislation, and enclosure of the land. Having referred to the appointment of committees on the subject by the Entomological Society of London and our own society, Mr. Tremayne proceeded to deal with these three remedies separately. The first two he thought could only be made useful as auxiliaries, but real good might be done by a judicious enclosure of some of our collecting-grounds, and he suggested the formation of a central committee, elective if possible, with power to grant passes to respectable naturalists on the recommendation of their societies. This, he thought, with the assistance of an Act of Parliament, and the cultivation of a higher spirit in the rising generation of naturalists, and an attempt at boycotting the over-collectors, would do something towards meeting the evil. He was quite willing to see some of the collecting-grounds temporarily enclosed altogether, if necessary for the protection of species. It would also be necessary to define over-collecting with regard to certain species, and the Committee in our own society had been formed largely with the view of recommending limits to the collecting of certain species amongst ourselves. But if any success were to be achieved, naturalists must pull altogether and leave no stone unturned to stop the evil. It was clearly the duty of our society to do what it could in the matter, and we must each submit to be loyally bound by the will of the majority. Mr. Bacot thought that over-collecting would probably die a natural death—in fact, it was already

doing so. As knowledge of animals and plants grew gradually more complete, there would be less need for collecting; and the knowledge that would then be required would be chiefly that about living animals and plants, and the bother and trouble of private collections would lead to their inclusion in museums. The approach of collectivism would also aid in this, as the "money-value," now one of the chief reasons for extensive collections of Lepidoptera, at any rate, would cease to form a factor in their continuance. The money-value was, of course, only an indirect cause of over-collecting, but was, nevertheless, a very powerful one. The extermination of many species would, of course, continue, and must do so as long as men increase and multiply. But it seemed doubtful whether over-collecting ever did more than finish off slightly more rapidly the already rapidly diminishing species. These remarks applied to scientific collecting. As regards commercial collecting, such as killing birds for aigrettes or plumes, or butterflies for wall-decorations, that was quite another matter. Agitation would probably do much good, but he did not think at present that any legal steps could be taken, especially as the chief offenders seemed to be among the older school of entomologists, who had already filled their series; whilst any laws on the subject would press hardly on the younger men, who, he thought, were far less likely to do harm. He was strongly opposed to any idea of enclosure of the land. Mr. Frost followed. Mr. Battley thought the idea of reducing collecting to a system was too dreadful. He was informed that Mr. Tutt's recent statements in the "Record," as to *Lycena arion* were inaccurate, and he saw great difficulties in the way of legislation. Many of those who were now doing the most shouting in the matter had themselves been the greatest exterminators. Mr. Watton thought that of the remedies suggested by Mr. L. J. Tremayne boycotting was the most feasible, and suggested the possibility of introducing a rule into our society, limiting the number of exhibits in certain species. Miss Simmons deprecated the publicity of the matter, and urged the cultivation of a high moral tone among the rising generation. Mr. Simes pointed out that publication would advertise the best spots for insects. With regard to the difficulty arising from the "money-value" of certain species, he thought this might be met by careful transplantation from Continental stocks which would undermine the value of *Lycena arion*, for instance, in the British market. Mr. Woodward pointed out that the long series sometimes seen in collections are not necessarily the result of over-collecting, being often obtained by breeding, suggested that it might be advisable to label those thus obtained. Mr. Dadd thought that exchange had a great deal to do with the matter. Mr. Harvey wanted to know whether Mr. L. J. Tremayne suggested the lands were to be closed to everyone, or only to naturalists. If so, how was the naturalist to be distinguished? Mr. R. W. Robbins thought we should discourage as much as possible the purchase of British specimens and spread the idea that a British specimen was of no more value than a foreign one. He pointed out that the pass system was already in vogue at Chattenden Wood, where it had been of very little use in stopping over-collecting. He agreed with previous speakers in opposing enclosure of the land. Mr. Bacot proposed the following resolution: "That this Society is strongly opposed to legislation or the closing of collecting-grounds to entomologists or others." This was seconded

by Mr. Simes, and carried by twenty to one. Mr. Prout said that if the dealers were left to do their very worst we should only lose about twelve species. Mr. Prout proposed the following supplemental resolution: "But that, while deprecating action on the lines indicated, the Society renews its pledge to the Entomological Society of London to assist their committee by all the means in their power." This was seconded by Mr. Bacot, and carried unanimously. A vote of thanks to Mr. L. J. Tremayne terminated the proceedings.—February 25th, 1897, Mr. C. B. Smith, Vice-President, in the chair. Exhibits: Mr. Bacot, larvæ of *Bombyx quercus* (received from Mr. Goymour), also of *B. spartii* and *B. quercus* (received from Mr. Warburg), on which he read extensive notes. Mr. Battley, a few *Abraxas grossulariata* selected from a large number bred from Stamford Hill larvæ. One specimen had the yellow in the transverse band almost absent, owing to the spread of the black spots. Mr. Prout, four continental examples of *Thera variata*, Hb., and four examples of *T. obelisca*, bred from St. George's Hills, Weybridge, which latter Doubleday held to be a distinct species. Mr. Prout said it was highly probable he might prove to be right. Rossler said that the form *variata* occurred on the *Pinus abies*, the var. *obeliscata* on *Pinus sylvestris*. Mr. Prout also exhibited two continental specimens of *Dianthæcia luteago*, and two Irish specimens of the strikingly contrasted var. *barrettii*. Mr. Harvey recorded three *Nyssia hispidaria* and several *Hybernia leucophaea* and others of the genus *Hybernia*, from Epping Forest, taken February 14th; but on a later day he had seen only *H. marginaria*, and on February 19th he had only found *H. marginaria*, one *Cheimatobia brumata*, and two *Anisopteryx æscularia*. He had not seen any *Asphalia flavicornis*. Mr. Prout remarked that *Asphalia flavicornis* had been out at Wimbledon for about a week. Mr. C. Nicholson read a paper, entitled "Stars, Star Clusters and Nebulæ," which was very heartily received, and a vote of thanks to Mr. Nicholson terminated the proceedings.—Lawrence J. Tremayne, Hon. Secretary.

CITY OF LONDON ENTOMOLOGICAL AND NATURAL HISTORY SOCIETY.—Tuesday, February 16th, the President in the chair. Messrs. W. R. Dadd and Norman E. W. Merton were elected members of the society. Exhibits: Mr. Bacot, two broods of *Tæniocampa stabilis* with their female parents; No. 1, of nineteen specimens, contained seven males (36.8 per cent.) and twelve females (62.2 per cent.); No. 2 contained ten specimens, the sexes being equally divided. All the specimens were much smaller than their female parents (hardly larger than *T. cruda*). Mr. Bacot also exhibited twenty-two specimens of *Demas coryli*, bred, during August, 1896, from ova laid by a female taken in Epping Forest by Mr. A. F. Bayne last April. These contained twelve females (or 54.5 per cent.) and ten males (or 45.5 per cent.). Mr. Bacot also exhibited twenty-three specimens of *Ennomos quercinaria*, containing thirteen males and ten females, bred in 1896 from a male and female of his 1895 brood. The parents of both broods were also exhibited. Mr. Bacot said that a comparison of the 1896 brood with the far larger brood of 106 specimens reared in 1895 showed that the proportion of males to females was almost exactly reversed; the figures for the 1895 brood were 56.6 per cent. females and 43.4 per cent. males, while for the 1896 brood they were 43.5 per cent. females and 56.5 per cent. males. Lastly, Mr. Bacot exhibited three male and four female specimens of *Ennomos quercinaria* bred in

July, 1896, from ova given him by Dr. Buckell. One had no trace of suffusion, the remaining six all being strongly marked in this direction, and one male in particular having the whole ground colour of both wings of a smoky hue instead of the usual bright yellow. Mr. Bacot read notes on all his exhibits. Mr. Heasler exhibited a specimen of *Dromius quadrinotatus*, on which he read some notes.—Tuesday, March 2nd, 1897, the President in the chair. Mr. C. Fenn, F.E.S., was elected a member of the society. Exhibits: Mr. Dadd, *Tephrosia crepuscularia* and *T. biundularia* (?), var. of *Hypsipetes sordidata*, *Lythria purpuraria*, *Hadena satara* and *H. adusta*, *Sphinx pinastri* and other species from Dakota, U.S.A. Dr. Buckell, exhibiting as a visitor, showed specimens of *Cænonympha typhon*, on which he read notes. Mr. Bacot exhibited 122 specimens of *Amphidasystrataria*, bred during 1896 from the ova of a male and female of one of his 1895 brood. He also exhibited the 1895 brood together with its parents, which were bred from larvæ beaten in the New Forest in 1893. Mr. Burrows exhibited (a) larvæ of *Orgyia gonostigma*, hatched July, 1896, hibernated in bag out of doors on oak; (b) same species a full generation ahead, hatched September 1st, 1896, hibernated indoors; (c) a single larva believed to be *Apamea ophiogramma*, embedded in root-stem of striped-ribbon grass. With regard to the double broods of *O. gonostigma*, in 1887 the imagines emerged on June 28th, the ova hatched on July 18th, and the larvæ pupated on August 30th. In 1893 the imagines emerged on June 14th, the ova hatched on June 27th, the larvæ pupated on August 13th; and the imagines again emerged on August 25th, and the ova again hatched on September 15th. In 1896 the imagines emerged on June 22nd, the ova hatched on July 2nd, the larvæ pupated on August 3rd; the imagines again emerged on August 15th, and the ova again hatched on September 1st. Mr. Garland exhibited *Aglais (Vanessa) urticae*, taken at rest upon a brick wall at Harrow Green, Leytonstone, about 10 o'clock in the morning of February 10th, and bred male varieties of *Hybernia defoliaria*, being larger than captured specimens. Mr. Newbery exhibited *Bruchus lentis* from Egyptian lentils. He read notes: "This species is erroneously stated to be without a thoracic tooth by both 'Cox' and 'Fowler,' although the contrary is stated in the original description." Mr. Tutt read a paper entitled "The origin of the Lepidoptera," in which he gave a summary of the latest facts at our disposal on this subject, from which it appeared that the opinion is pretty generally held that lepidoptera and trichoptera, originated from a common neuropterous stock, and that there is considerable probability that the Diptera originated from the same source. Dr. Buckell suggested that it might be as well to consider how broad was the base which we were trying to discover. Our present species had not necessarily evolved from a single species or a single pair. There was very likely more than one stem.—*Laurence J. Tremayne, Hon. Sec.*

CAMBRIDGE ENTOMOLOGICAL AND NATURAL HISTORY SOCIETY.—A meeting was held on April 30th, the President in the chair. Dr. Sharp called attention to a peculiar structure which he detected some years ago in *Chrysalis madagascariensis*, better known as *Urani rhiphen*: On each side of the second abdominal segment there is an ear-like opening, usually much concealed by overlapping scales, giving entrance to a chamber which extends to the middle line and forwards towards the base of the abdomen, so that a considerable space

in the anterior and upper part of the abdomen is occupied by the chambers. At the anterior external part of this depression or chamber there is a second vesicle-like chamber formed by a delicate membrane. He considered this structure to be some kind of sense organ, and thought it must be of great importance to the creature, as it occupies a large area of the abdominal region. It is independent of sex and, apparently, occurs in all the members of the families Uraniidæ and Epiplemidæ. Mr. Oberthur had kindly supplied him liberally with dried specimens for the examination of this organ, but fresh individuals, or some well preserved in spirit, are necessary before any of the finer details of the structure can be ascertained.—*L. Doncaster, Hon. Sec., King's College, Cambridge.*

HULL SCIENTIFIC AND FIELD NATURALISTS' CLUB.—The usual fortnightly meeting of the Club was held in the Friendly Societies' Hall, Albion Street, Hull, on Wednesday evening, the 12th May, the President, Dr. J. Hollingworth, M.R.C.S., occupied the chair. Mr. J. F. Robinson read a detailed report of the excursions made by the Club the two previous Saturdays, viz., to Little Weighton and Swine respectively. On the former date the members joined the Hull Geological Society in a ramble along the wolds. Hornbeam (*Curpinus betulus*) was noticed growing in a wild state in the hedgerows between Little Weighton and Blue Stone Bottoms. At Swine the party had a very profitable outing, especially the botanists. In addition to a magnificent show of orchids, bluebells, broom, etc., specimens of a rare plant for this district, the bistort (*Polygonum bistorta*) were secured in Coniston Coppice. Mr. J. R. Boyle, F.S.A., conducted the party over Swine Church, and also gave a description of "Castle Hill" on this occasion. Mr. Phillip referred to the diatoms found on these excursions, and showed some of the most beautiful with the aid of the microscope. Photographs of the country in the neighbourhood of Little Weighton were handed round by the President. Mr. C. Waterfall gave an account of a visit he had paid to Hornsea Mere the previous Saturday, and handed round several of the plants he had collected, two of which, *Teraxacum officinale* var. *palustre* and *Salix triandra* are additions to the list of East Riding plants. The exhibits included a boulder of rhomb-porphyr from the beach at Hornsea, by Mr. Waterfall; several interesting cretaceous and other fossils by Mr. J. W. Boulton; a collection of ancient British flint arrow-heads and "scrapers" found on the fields at Hunmanby, by the Secretary, on behalf of Mr. Leppington; and some botanical specimens by Mr. Knight. Mr. Wm. Nicholls was elected a member of the Club. Mr. G. H. Hill read a note on the dog's mercury (*Mercurialis fœrennis*), which he illustrated with some beautifully coloured diagrams. The lecture of the evening was then delivered by Mr. J. F. Robinson, on "Spring Flowers." In a delightfully interesting manner the lecturer described the plants which adorn the woods, ditches, fields and hedgerows at this season of the year. In addition he gave the results of his observations relating to the colouring of these early flowers. It appears the majority of "the flowers that bloom in the spring" are either yellow, green or brown, and Mr. Robinson stated what he thought was the reason for this. The lecture was illustrated by numerous specimens of spring flowers collected in the neighbourhood.—*T. Sheppard, Hon. Sec., 78, Sherburn Street, Hull.*

## NOTICES OF SOCIETIES.

## THE GEOLOGISTS' ASSOCIATION OF LONDON.

*Excursions and Conductors.*

- June 5 to 8.—Whitsuntide. Cheltenham (Gloucestershire). E. Wethered, F.G.S., and S. S. Buckman, F.G.S.  
 „ 19.—Whole day. Leighton (Bedfordshire). A. C. G. Cameron.  
 „ 26.—Merstham (Surrey). G. J. Hinde, Ph.D., F.R.S., and W. Whitaker, F.R.S.  
 July 3.—Woking. F. Meeson.  
 „ 10.—Whole day. Peterborough (Northamptonshire). A. N. Leeds, F.G.S., and A. S. Woodward, F.G.S.  
 „ 17.—Bishop's Stortford (Herts.). Rev. Dr. Irving, F.G.S.  
 „ 26 to 31.—Long Excursion. Edinburgh. Prof. James Geikie, LL.D., D.C.L., F.R.S.; J. G. Goodchild, F.G.S., and H. W. Monckton, F.G.S.  
 Sept. 4.—Whitchurch, Oving, Quainton. A. M. Davies, F.G.S. Baker Street, 9.37 a.m. for Waddesdon Manor.  
 „ 18.—Holmesdale Valley. W. J. Lewis Abbott, F.G.S. Victoria (L. C. and D. R.), 1.30 p.m. for Oxford.

For particulars of these excursions, apply to Horace W. Monckton, Esq., Secretary for Excursions, 10, King's Bench Walk, Temple, E.C.

LONDON GEOLOGICAL FIELD CLASS.—Conductor, Professor H. G. Seeley, F.R.S. (*Vide* SCIENCE-GOSSIP, Vol. iii., p. 328.)

- June 12.—Coulson to Merstham. Cannon Street, 2.17 p.m.  
 „ 26.—Aylesford to Maidstone. Cannon Street, 2.37 p.m.  
 July 3.—Halling to Rochester. Cannon Street, 2.42 p.m.  
 „ 10.—Hildenboro' to Sevenoaks. Cannon Street, 2.23 p.m.  
 „ 17.—Upnor to Rochester. Cannon Street, 2.37 p.m.  
*Hon. Sec., R. H. Bentley, 43, Gloucester Road, South Hornsey, N.*

## THE SOUTH LONDON ENTOMOLOGICAL AND NATURAL HISTORY SOCIETY.

- June 5-7.—Field Meeting: Ashdown Forest (Members intending to go please write to Secretary, Mr. H. J. Turner, 13, Drakefield Road, S.E.)  
 July 3.—Reigate.

## NORTH LONDON NATURAL HISTORY SOCIETY.—The following are amongst the fixtures for next session:

- June 4-7.—Excursion to the New Forest.  
 „ 10.—Debate: "Is Vivisection Justifiable?"  
 „ 19.—Half-day Excursion to the Lea Valley.  
 „ 24.—"Clothes-Moths." J. B. Casserley.  
 There will also be a special-family discussion, entitled "The Liparidae," to be opened by A. Bacot on some date not yet fixed.—*Lawrence J. Tremayne, Hon. Secretary.*

## LANBETH FIELD CLUB AND SCIENTIFIC SOCIETY.—We have received the following list of fixtures for the forthcoming session:

- June 7.—Whit-Monday.—Outing to Cheshunt.  
 „ 19.—Outing to Caterham. *H. Wilson, Hon. Sec., 14, Melbourne Square, Brixton Road.*

## HULL SCIENTIFIC AND FIELD NATURALISTS' CLUB.

*Excursions.*

- May 29.—Barton and South Ferriby. Boat from Corporation Pier at 1.40 p.m. Return fare 1s.  
 June 7.—Goole Moor.  
 „ 12.—Aldbrough.  
 „ 26.—Pelham Woods.

*Meetings.*

- June 9.—"The Extinct Animals of Holderness." Mr. T. Sheppard.  
 „ 23.—"Crabs." Mr. F. W. Fierke, M.C.S.  
 For particulars, apply to Mr. T. Sheppard, Hon. Sec., 78, Sherburn Street, Hull.

## LEICESTER LITERARY AND PHILOSOPHICAL SOCIETY.

- June 5 to 9.—Excursion.  
 „ 23.—"Notes on Arancidæ (Spiders) of Leicestershire."

## NOTTINGHAM NATURAL SCIENCE RAMBLING CLUB.

- Geological Section.*—Leader, Mr. J. Shipman, F.G.S.  
 May 29.—Trowell, Strelley, Kimberley, etc. Meet Midland Station, 2.30 p.m.  
 June 26.—Drive to East Leake. Meet front University College, 2.30 p.m. Fare, including drive, 24 miles, and tea, 2s. 6d.

July 10.—Trowell, Stony Cloud and Sandiacre. Meet Midland Station, 2.30 p.m.

Aug. 28.—Annual Excursion. Lincoln. Fare (special train), 1s. 6d.

Sept. 11.—Hucknall Torkard and Long Hills. Meet Midland Station, 1.30 p.m.

*Botanical Section.*—Leader, Mr. W. Stafford.

June 19.—Lambley Dumbles. Meet G.N.R. Station, 2.40 p.m.  
 July 24.—Red Hill and Bestwood. Meet opposite Mechanics' Hall, 2.30 p.m.

Aug. 14.—Nottingham Arboretum. Meet Waverley Street Entrance, 2.30 p.m.

Sept. 18.—Radcliffe and environs. Meet G.N.R. Station, 1.45 p.m.

Oct. 16.—Annual Meeting, Rambling Club, Natural Science Laboratory, University College, Nottingham, 4 p.m. Tea, soirée and exhibition of collections made during season. *W. Bickerton, Hon. Sec., 187, Noel Street, Nottingham.*

## NOTICES TO CORRESPONDENTS.

TO CORRESPONDENTS AND EXCHANGERS.—SCIENCE-GOSSIP is published on the 25th of each month. All notes or other communications should reach us not later than the 18th of the month for insertion in the following number. No communications can be inserted or noticed without full name and address of writer. Notices of changes of address admitted free.

NOTICE.—Contributors are requested to strictly observe the following rules. All contributions must be *clearly* written on one side of the paper only. Words intended to be printed in *italics* should be marked under with a single line. Generic names must be given in full, excepting where used immediately before. Capitals may only be used for generic, and not specific names. Scientific names and names of places to be written in round hand.

THE Editor is not responsible for unused MSS., neither can he undertake to return them, unless accompanied with stamps for return postage.

SUBSCRIPTIONS.—Subscriptions to SCIENCE-GOSSIP, at the rate of 6s. 6d. for twelve months (including postage), should be remitted to the Proprietors, 86, St. Martin's Lane, London, W.C.

THE Editor will be pleased to answer questions and name specimens through the Correspondence column of the magazine. Specimens, in good condition, of not more than three species to be sent at one time, *carriage paid*. Duplicates only to be sent, which will not be returned. The specimens must have identifying numbers attached, together with locality, date and particulars of capture.

ALL editorial communications, books or instruments for review, specimens for identification, etc., to be addressed to JOHN T. CARRINGTON, 1, Northumberland Avenue, London, W.C.

## EXCHANGES.

NOTICE.—Exchanges extending to thirty words (including name and address) admitted free, but additional words must be prepaid at the rate of threepence for every seven words or less.

WANTED, eggs of cuckoo, with those of foster parents.—W. Wells Bladen, Stone, Staffordshire.

MICRO slides or cabinet wanted in exchange for 50-in. astronomical telescope; several good diatom slides for exchange.—R. Borrows, 18, Pensbury Street, Darlington.

EGGS FOR EXCHANGE.—Black-headed gulls, crows, terns. Wanted, herons or razorbills.—John Duguid, 95, Gallowgate, Aberdeen.

WANTED, specimens of minerals and pebbles in exchange for interesting and beautifully dried plants (British or foreign) or cash.—David S. Fish, 12, Fettes Row, Edinburgh.

NATAL butterflies, set and named. What offers?—E. G. H. Tyrrell, 42, Raven Street, Pietermaritzburg, Natal, South Africa.

OFFERED, two honey ants (*Camponotus inflatus*) from Central Australia, in exchange for twenty typical mineral specimens; forty ants available.—E. J. Bradley, Engineer-in-Chief's Office, Adelaide, South Australia.

COLE'S "Studies in Microscopical Science"; cash offers requested for above, complete, unbound. The accompanying slides are in polished pine cabinet, with glass door. Only accepted offer answered.—A. W. Dennis, 48, Mansfield Street, London, N.E.

## A PATRON OF SCIENCE.

THERE died on June 6th last, in his seventy-fourth year, at his estate, Almnäs, near Hjo, Lake Wetter, Sweden, Baron Oscar Dickson, the well-known patron of scientific explorations. He was best remembered by his great services in assisting in the equipment of expeditions to the Arctic regions, one of the most successful with which he was associated being that of Professor, afterwards Baron, Nordenskiöld in the "Vega" in 1878-1880. That expedition was initiated on the representation of Professor Nordenskiöld, in 1876, when he placed his plan before the King of Sweden and Norway. The King warmly took up the proposal on account of the great experience Nordenskiöld had gained in two former explorations of the Northern Palaearctic coasts: first in a walrus hunting sloop, the "Proeven," and afterwards in a steamer named the "Ymer." On the invitation of King Oscar, an important dinner party took place in January, 1877, to discuss the project. Among those invited by the King to meet the projector was Dr. Oscar Dickson, a wealthy Gothenburg merchant, and the subject of this notice. There were also there Baron F. W. von Otter, the Minister of Marine, a sailor who had gained experience in Arctic waters in 1868

and 1871, and others who had also been in like expeditions. After dinner Nordenskiöld's programme was laid before the meeting, which became lively with discussion on the probabilities of success, by no means all the speakers being in its favour. In the end, His Majesty declared himself convinced of the practicability of the proposed voyage to discover a north-east passage to the Pacific Ocean. Further, the King volunteered his official patronage and private financial support. Dr. Oscar Dickson also offered financial help, and became the banker of the "Vega" expedition, the cost in the end being borne equally by the King, Dr. Dickson, and another patron of exploration of the Arctic, Mr. Sibiriakoff.

This was not the first assistance given to a like cause by he who was destined to become Baron

Dickson. In 1868 he helped an expedition to Spitzbergen, also others in 1870 and 1876, to the Yenisej. His energies and purse were directed to the more practical side of these scientific voyages, such as the opening of a trade route to the Siberian rivers, Lena and Yenisej, which are numbered among the greatest streams of the world.

At a later period Baron Dickson found disappointment awaiting his efforts to form an Antarctic expedition. Though all his powerful influence was used to bring about that voyage of discovery, it failed for want of support and had to be abandoned. The frequent visits to this country of Baron Dickson caused him to be well-known here, where he always found friends. Among his

recreations the subject of this notice cultivated scientific breeding of horses, the result being that he much improved the class of those animals in the neighbourhood of his own estate. He was a considerable buyer of high-class stud horses on his visits to England. These were sent to Sweden for the purpose of raising the standard of breed among horses in his own country.

Considering the number of men in modern times who have amassed great riches, it is surprising that

more have not become patrons of science. It is hardly necessary to remind those who can well afford to do so, how many are the objects connected with science which could be benefited by their generosity; nor how splendid may be the results for mankind. It would be ungracious, however, not to feel grateful to such men as Dickson, Lick, Monde, Harmsworth and others, for their munificence. To them the world of science is under deep obligations; for if we review the past and probable scientific result of their rich gifts, much which is now common knowledge would have still been among the unknown. Could any earthly satisfaction be greater than to feel that one has been able to help in the progress of scientific knowledge and thus do a great and lasting good for one's fellow creatures?



BARON OSCAR DICKSON.



## COAL IN KENT.

BY H. E. TURNER, B.A.\*

THE present month has seen the successful flotation of the third company that has been formed with the object of exploring the county of Kent for the mineral wealth that is supposed to be buried deep below the surface. The capital of £250,000 required by the promoters of the "Kent Coal Exploration Company" has been subscribed three times over in two or three days. Considering that this latest venture is a purely speculative one, inasmuch as no coal has actually been discovered within the area of its proposed operations, the result of the Company's appeal for funds must be regarded as an eloquent testimony to the confidence now reposed in the deductions of geologists. Disparaging allusions have often been made to geology as the most speculative of all the sciences, and to a certain extent it may be open to that reproach. In its practical application to mining, however, geology has rendered services that no one who is qualified to express an opinion can fail to appreciate. Many a fortune has been made by following its guidance, and many a one lost by neglect of its teachings, while vast stores of mineral wealth have been rendered available that would otherwise have remained hidden and unknown.

The question of the existence of coal under our south-eastern counties is a most momentous one. It touches us as a nation whose unparalleled advance in wealth during the present century has been due, in no small measure, to those bountiful supplies of coal and iron which have given us our manufacturing supremacy. Bountiful, it is true—but not inexhaustible. Our present coalfields have an enormous output, but they have to meet an ever-increasing demand; their boundaries may be far wider than we anticipate, but they must have a limit. Whether our coal supply is sufficient to last 275 or 1,275 years longer—to take the divergent opinions expressed in the report of the Coal Commission of 1871—the fact remains that we are living, not upon our interest, but upon our capital. It behoves us, therefore, as the stewards of posterity, to lose no opportunity of rendering available those hidden supplies of wealth that doubtless exist, and thus to provide a measure of compensation for our present lavish expenditure. However pressing the claims of posterity, they do not appeal to us with the same force as present interests, and so this coal question probably touches us still more closely as inhabitants of a

district which at present is further removed than any other from our great centres of supply. Our solicitude for the comfort and prosperity of generations yet unborn must necessarily be of a somewhat platonic character, whereas our peace of mind is apt to vary inversely as the demands upon our pockets. A reduction in the price of coal by one third or one fourth would doubtless be viewed with equanimity by most householders in this part of the country, if not by the railway companies north of the Thames. Except in the unlikely event of a monopoly, such a result would probably accrue from the establishment of successful collieries in our southern counties.

It is not from the side of political economy or individual finance that I wish to view this question, but I feel a very special interest in the realization of a bold theory propounded by an eminent geologist forty years ago, to most minds based on very slender evidence, often ridiculed, but now triumphantly vindicated. Probably few of us have had the time, the opportunity, or the inclination to study this theory, and to form our own opinions upon it. Other branches of science may have claimed our attention, and so a brief *resumé* of the arguments and course of events that have led to the discovery of coal in Kent, with all its contingent possibilities, may not prove unwelcome.

It would be well, however, to make a few preliminary remarks respecting the geological position of coal, and its mode of occurrence in what are known as "coal basins." It is well known that this important mineral is practically confined to the geological formation termed the "coal measures" which form the upper division of the Carboniferous system. The two other principal divisions in descending order are the millstone grit, a shallow water deposit varying from 500 to 1,000 feet in thickness, and the carboniferous limestone, formed as a rule in deeper water, and from 500 to 2,500 feet thick. The whole system is of vast antiquity, belonging as it does to the group of ancient sedimentary rocks known as the palæozoic or primary, of which, however, it is one of the most recent members. The coal measures are sometimes of enormous thickness—from 10,000 to 12,000 feet. For instance, in the South Wales coalfield, the coal is being distributed in seams more or less throughout, but these form a very insignificant proportion of the whole, being often separated by massive beds of sandstone, shale and clay. The most profitable seams occur in the upper and middle part of the coal measures. The thickest

\* Abstract of a paper read before the South-Eastern Union of Scientific Societies at Tunbridge Wells, May 22nd, 1897.



seam in England is the ten-yard seam of the Dudley coalfield, but this is quite exceptional, a few feet being generally the maximum. These coal seams represent successive periods during which a luxuriant and very characteristic vegetation covered an old, low-lying swampy land surface, which was subject to frequent oscillations of level and consequent incursions of the sea, each of which resulted in the deposition of sand and mud on the peaty matter that had accumulated during the previous period of vegetable growth. At last a marked upheaval brought about conditions unfavourable to further development of these incipient coal beds, thus bringing the Carboniferous period to a close. Subsequent disturbances eventually modified in large measure the general distribution of the coal-bearing strata. Together with the underlying formations they were thrown into a series of longitudinal and transverse folds. Nature's ceaseless agents of destruction—air, frost and water—came into play, and slowly but surely removed the crests of these folds, wearing their way down to still lower and lower strata, until the coal measures, and in many cases the underlying beds, disappeared. On the other hand, the coal measures between the folds being from their position less exposed to denudation, remained comparatively intact, but isolated from those with which they had formerly been continuous, lying in troughs or basins surrounded by older rocks.

Thus one of the folds above referred to extended north and south from the Cheviots into the heart of the Midlands, forming a ridge now known as the Pennine Chain, with its strata dripping east and west. Untold ages of wear and tear have, however, stripped the summit of this ridge of its coal measures, laid bare the millstone grit below, and to a large extent the carboniferous limestone also. In this way the coalfields on the east of the Pennine Range became separated from those on the west, while a similar disturbance and denudation that appears to have taken place subsequently in a transverse direction through the northern parts of Lancashire and Yorkshire have cut off the Northumberland and Durham coalfield from that of Yorkshire, and also isolated the Cumberland from the Lancashire coalfields. In a similar manner, the coal basin of the Forest of Dean has been separated from that of South Wales. The intervening country is now largely occupied by rocks far older than the carboniferous limestone—all exposed by denudation. No better examples could be given of coal basins than these two. The coal measures occupy a dish shaped hollow formed by the underlying millstone grit which crops up all round, and together with the carboniferous limestone below forms at the surface the edge of the basin.

The South Wales coalfield is bounded on the

south by a tract of rocks consisting of carboniferous limestone, which in many places has been denuded down to the underlying formation known as the Devonian or Old Red Sandstone. These occupy the extreme southern portions of Pembrokeshire and Glamorganshire, but their continuity is interrupted by the bays of Swansea and Carmarthen, and also, just south of Cardiff, by the estuary of the Severn, but on the eastern side of the estuary they reappear in the form of the Mendip Hills of Somersetshire. Still further east they disappear under newer formations, the whole tract being one of the transverse folds formed after the close of the Carboniferous period, and as we shall see later it has an important bearing on the question of coal in our southern counties. On the northern flanks of the Mendip Hills we find the millstone grit and coal measures of the Bristol coalfield, largely hidden, however, by newer deposits of secondary age, and only appearing at the surface where these have been removed by denudation.

We are now in a position to appreciate the reasoning by which Mr. Godwin-Austen, in 1855, was led to put forward the theory that an extension of these western coalfields might be found at a workable depth under our south-eastern counties. At first sight the idea seemed a wild one. In proceeding eastwards from Bristol we meet in succession immense thicknesses of newer secondary rocks, all dipping eastwards in such a manner as apparently to place the palæozoic rocks at a depth of at least six or seven thousand feet below the surface in the neighbourhood of London, and consequently entirely beyond our reach. Besides, there seemed no guarantee that deposits of carboniferous age existed at all so far east; the formation might thin out, or, if not, might change its character in so great a distance—a not unlikely possibility. Mr. Godwin-Austen was able to reveal, however, certain points of similarity between the coalfields of Belgium and north-east France and those of Somersetshire and South Wales, and also between the Ardennes district and the Mendip Hills, which respectively bounds those coalfields on the south. The Ardennes form an elevated region of palæozoic rocks, bearing on their northern slope a series of long narrow detached coal-troughs, stretching south-west along the valley of the Meuse from Aix la-Chapelle through Liège and Namur, and continued through Mons and Charleroi to the French frontier, and then north-west by Valenciennes and Douai to within ten miles of St. Omer or thirty from Calais. From the physical structure of the district, the lithological character of the strata, and the organic remains which they contain, Mr. Godwin-Austen was convinced that the anticlinal or ridges of the Ardennes was a continuation of that of the Mendips, and that if we could strip south-east England of its

present covering of secondary rocks, we should find this palæozoic ridge pursuing a devious, though generally east and west course, approximately parallel to, but south of, the Thames and Kennet, with coal measures on its flanks, preserved in long narrow basins like those of Belgium. He considered, moreover, that the superincumbent secondary rocks would be found to thin out in an eastwardly direction, and to rest upon this palæozoic floor at no great depth below the surface.

It was not long before evidence was forthcoming of the general soundness of Mr. Godwin-Austen's views. On the advice of Mr. (afterwards Sir) Joseph Prestwich, the Hampstead Water Company had been boring at Kentish Town through the tertiary strata and underlying chalk and gault of the London Basin in order to tap the plentiful supply of pure water which it was anticipated would be reached in the Lower Greensand below. Before Mr. Godwin-Austen's paper was printed, the result of the boring came to hand, and proved to be of a most unexpected character. His theory of the thinning out of the secondary rocks in this direction was more than realised. The whole of the secondary rocks below the gault, including the Lower Greensand, Wealden, Jurassic and Triassic were found to be absent, for at 1,100 feet from the surface, red sandstones and shales were met with, which are now generally regarded as belonging to the Devonian or Old Red Sandstone period, and therefore antecedent to the Carboniferous.

That Mr. Godwin-Austen's palæozoic ridge had been actually struck was soon confirmed by many deep borings in the London basin, all undertaken with the purpose of finding water. One at Crossness, on the south bank of the Thames, reached similar rock at about 1,000 feet down, but the absence of organic remains again rendered the determination of its age somewhat uncertain. In 1877 more positive evidence was forthcoming. A boring for water to supply a brewery at the corner of Tottenham Court Road and Oxford Street encountered sixty-four feet of oolitic strata after piercing the gault, and then at 1,064 feet from the surface entered upon dark-coloured shale, dipping south at an angle of 40 degrees and containing fossils of Upper Devonian age. Palæozoic rocks, probably Devonian, have also been reached at Streatham and Richmond, at depths of about 1,000 and 1,200 feet respectively.

At Turnford, near Cheshunt, twelve miles north of London, strata and fossils resembling those of the Tottenham Court Road boring, and therefore Upper Devonian, were met with at a depth of 980 feet, while the upper beds of the next older formation—the Silurian—were found at a depth of less than 800 feet at Ware, eight miles further north. Here the beds dipped about 40 degrees also, and probably to the south.

At Harwich, dark slaty rock was struck below the Gault about 1,000 feet below sea-level. A fossil of doubtful character inclined Mr. Prestwich to the opinion that this rock, was of Lower Carboniferous age, but a recent careful microscopical examination on the part of Mr. W. W. Watts has induced the latter to reject the supposed fossil as merely a peculiar fracture, and to refer the rock on lithological grounds to some formation older than the Carboniferous—probably Upper Silurian. Similar palæozoic rocks have been recently found at a depth of about 1,000 feet at Slutton and Weeley, a few miles to the west and south-west of Harwich, and also at Culford, near Bury St. Edmunds, at little more than half that depth.

It has thus been amply demonstrated that the upper cretaceous rocks of the London Basin repose on a palæozoic floor at a depth nowhere much exceeding 1,000 feet; that north of the Thames, at least, this floor is composed of beds older than the Carboniferous, and that the general dip of these old rocks is about forty degrees to the south. The inference, therefore, is that with Silurian beds under and to the north of Ware, and Devonian under Cheshunt and London, there is a strong probability that the Lower Carboniferous will set in somewhat to the south of London, and the coal measures still further south, perhaps in the neighbourhood of the North Downs or on the borders of the Wealden area.

This inference has been considerably strengthened by the actual discovery of coal measures near Dover a few years ago. For a long time past the French miners have been extending their operations in a north-west direction towards Calais, following up the course of the Belgian coalfield under the chalk by which it is ultimately covered, until at the present time there are collieries in full work within thirty miles of Calais and fifty miles of Dover. A boring at Calais revealed the still further extension of these coalfields towards our shores, and when, in 1882, the Channel Tunnel scheme was interdicted by the Government, Mr. Francis Brady, engineer to the Tunnel Company and the South-Eastern Railway, suggested to the directors that the staff of men retained to keep up the Tunnel Works might well be employed in a test boring for coal. The suggestion was adopted and crowned with success. A shaft was sunk from the surface to sea-level—a depth of 44 feet, from the bottom of which a bore-hole 18 inches in diameter was begun on the percussion system. After passing through 174 feet of Chalk, 8 feet of Upper Greensand, 121 feet of Gault, 241 feet of Lower Greensand and Wealden, and 613 feet of Jurassic strata, coal measures were reached at a depth of 1,157 feet from the surface, the first seam of coal met with being

15 inches thick. The bore-hole was then reduced to 9 inches, and eventually to 4 inches, and by the aid of the diamond-boring system the coal measures were pierced for 1,068 feet. Fourteen seams of coal were found with an aggregate thickness of 23½ feet, and of these eight might be regarded as workable, being 1½ feet or more thick, with a combined thickness of 19½ feet. The last seam encountered was the thickest, measuring 4 feet and lying 2,222 feet from the surface. As far as can be judged by the samples brought up by the borer, the coal is of excellent quality, bright, clean and bituminous, and standing well when tested against the best productions of our present coalfields. The beds that have thus been investigated appear on palæontological grounds to belong to the upper part of the middle coal measures, and therefore there is every probability that profitable beds of coal will be met with still lower down. The depth is by no means excessive, for most of the important coalfields of Britain are worked to a depth of 2,000 feet to 3,000 feet, and in Belgium to as much as 3,900 feet. Another important factor contributing to the probable success of the Dover coalfield is the circumstance that the coal measures are here practically horizontal throughout, which apparently indicates that the boring has pierced the middle of the basin, and that no great fear need be entertained of the continuity of the beds being broken by great dislocations or local disturbances.

With prospects such as these, the "Kent Coal Syndicate" was soon formed to work the venture, and acquired working rights under nearly 7,000 acres, adjacent to the boring. Two shafts are now being sunk, twenty feet and seventeen feet in diameter, one of which has already been carried to a depth of over 360 feet, or one-third of the way down to the first coal seam; and the other is not far behind it, so that in the opinion of those who are most sanguine, Kent coal will be in the market before the end of the year. The promoters estimate that the Dover colliery alone, with its present working rights over 7,000 acres only, will be able, at a low estimate, to produce a million tons a year for more than three-quarters of a century.

But although the result of the Dover boring has proved the existence of coal under a part of Kent, it does not give us the area of the coal-field, nor the direction in which it extends, and many borings will have to be undertaken before very precise information is forthcoming on these points. Arrangements are being made for a series of borings in likely spots by the Kent Coalfields Syndicate, the Mid-Kent Coal Syndicate, and the Kent Exploration Company, so that the vexed question will doubtless be solved before long.

If the Dover coalfield follows the same line as that of north-east France, *i.e.* a general north-west direction, we should expect to find it extending in the direction of Canterbury and Chatham, but it is quite possible that the line of coal-measures soon takes a more westerly direction, by Ashford and Maidstone, and then by Sevenoaks, Guildford, Basingstoke and Devizes to Bath. This is the view taken by most of our geological experts, but the 160 miles between Dover and Bristol have still to be explored; the coal basins, if they exist, are unlikely to be more than ten miles wide at the most, and in all probability much less; their direction is probably more or less sinuous, so that altogether there is still a considerable amount of uncertainty as to the mineral wealth of our south-eastern counties, and we must not be disappointed if many of the trial borings fail to reveal it. The labour and money expended on such will not be thrown away; each unsuccessful one will increase our knowledge of the composition of the palæozoic floor below us, and thus render the chances of future success more assured.

In the discussion which followed the reading of this paper, Mr. W. Watts pointed out that Mr. Godwin-Austen founded his theory on the warping of the earth's crust and the effect it had of throwing the strata into basins. The idea was not entertained seriously at first, but French observers had taken it up, and they had now seen the results at Dover.

Professor Seeley said he had some hesitation in speaking on so hypothetical a matter as the occurrence of coal in this part of England, and he pointed out that the bend in the strata in past ages might have been accompanied by the process of denudation, so that they could not speak with any certainty. He thought the vicinity of Tonbridge, according to the geological formation, was too far south. He described how the beds of rock thinned off to the north of Tunbridge Wells. They would fill up the area, and be thinner towards a centre under London, which afterwards became bent into a trough. Consequently there was a possibility that the coal basin might be indicated by the thinning off of the strata in the manner shown. The trough, so to speak, might have been denuded before any of these rocks on which Tunbridge Wells is situated had been laid down upon it. The whole problem was to seek where this basin of strata had got so thin as to allow the coal basins below to be reached. That was the real problem, and examining the structure at Weald, towards Canterbury and Maidstone, they found an angular bend in the great oval form of the Weald, where the chalk rocks bend northwards. Theoretically the valley of the Medway might be indicated as lying along the line of strata which had been referred to.

## ARMATURE OF HELICOID LANDSHELLS,

WITH A NEW FORM OF PLECTOPYLIS.

BY G. K. GUDE, F.Z.S.

(Continued from page 11.)

*PLECTOPYLIS shanensis* (figs. 48a-d), from Burma, was described by Dr. F. Stoliczka in the "Journal of the Asiatic Society of Bengal," xlii. (1873), p. 170, and figured in Hanley and Theobald's "Conchologia Indica" t. 149, ff. 8 and 9 (1876). Lieut.-Colonel Godwin-Austen described a supposed new species, under the name of *Plectopylis tvilamellaris*, in the "Proceedings of the Zoological

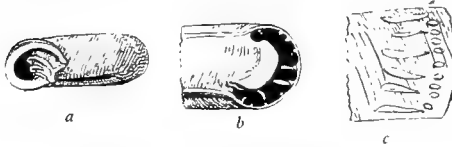
Fig. 48.—*Plectopylis shanensis*.

Society," 1875, p. 43, but he subsequently found it to be identical with the present species. ("Journal of the Asiatic Society of Bengal," xlvi. (1879), p. 2.) Mr. Nevill in his Handlist, p. 71, records specimens from Kuengan, Pegu. As the armature of this shell has never been figured, I am pleased to have an opportunity of now illustrating it. The shell is sinistral, discoid, with the apex a little raised; it is irregularly ribbed above and provided with fine spiral sculpture. There are from  $6\frac{1}{2}$  to 7 whorls, which are a little convex above, and rounded below; the last being much widened towards the aperture and abruptly and deeply deflexed. The umbilicus is wide and deep, and the aperture widely lunate. The peristome is white, strongly reflected and thickened, and the margins are united by a strong raised flexuous ridge, notched above and below. The parietal armature consists of a strong horizontal median fold, revolving over nearly half of the outer whorl, and united to the ridge at the aperture, but it is free posteriorly. A short distance beyond it occurs a strong vertical lunate plate, which is deflected posteriorly below, where it gives off a short support; on the anterior side of this vertical plate, also below, a strong horizontal fold is given off, extending a little over half the length of the median fold. A third horizontal thin fold, close to the lower suture, commences just below the vertical plate, and is united to the ridge at the aperture (see fig. 48d, which shows the shell with the outer wall removed, and fig. 48b, which gives the posterior view of the parietal and palatal armature). All three horizontal folds are visible from the aperture as seen in fig. 48a. The palatal armature is in two series: the

anterior series consists of six thin horizontal subequal folds, while the posterior series is composed of nine short denticles arranged in a vertical row (see fig. 48c, which shows the inside of the outer wall). The specimen figured is in the British Museum, and measures—major diam.,  $19\frac{1}{2}$  millimetres; minor diam.,  $15\frac{1}{2}$  millimetres; axis, 6 millimetres; it is from the Shan States. A specimen in the McAndrew collection in the University Museum of Zoology, Cambridge, labelled *Plectopylis reperussa*, proved on examination to pertain to the species now under consideration. It measures—major diam., 20 millimetres; minor diam., 15 millimetres; axis, 6 millimetres.

*Plectopylis stenochila* var. *basilia* (<sup>1</sup>) (figs. 49a-c), from Badung, Province of Hoo-Pé, was sent to me by Professor Oscar Boettger, of Frankfort. It has a more conical spire and the whorls are more flattened than in the type (see *ante* vol. iii., p. 204, f. 29); the periphery is acutely keeled, while in the type it is rounded. The parietal armature differs in having only four simple denticles anteriorly to the vertical plate, the second denticle being very

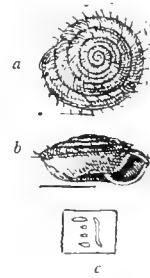
Fig. 49.—*Plectopylis stenochila*, var. *basilia*.

minute (see fig. 49c); the palatal armature is identical with that of the type.

*Plectopylis emoriens* (figs. 50a-d), from the Province of Hou-Nan, China, was described by Mr. Vincenz Gredler in the "Jahrbuch der Deutschen Malakozoologischen Gesellschaft," viii. (1881), p. 15. Mr. Heude, in Part 1 of his "Notes sur les Mollusques Terrestres de la Vallée du Fleuve Bleu," published in the "Memoires concernant l'Histoire Naturelle de l'Empire Chinois" (1882), p. 34, considered this form to be a variety of *Plectopylis fimbriosa*. The two forms, however,

(<sup>1</sup>) *Plectopylis stenochila*, var. *basilia*, n. var., differs from the type in the more conical spire, the more flattened whorls and the acutely keeled periphery.—Diam., 6-7 millimetres. Habitat, Badung, Province Hoo-Pé, China.

differ in many respects as indicated below, and I therefore follow Mr. Gredler in regarding *Plectoptylis emoriens* as a valid species. It appears never to have been illustrated, for the figure given erroneously under this name by Mr. Tryon, "Manual of Conchology," second series, iii. (1887),

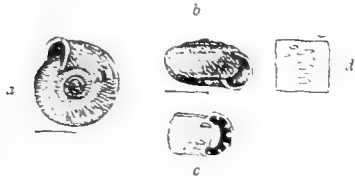

Fig. 50.—*Plectoptylis emoriens*.

t. 34, ff. 32-35, copied from Mr. Heude's work, is undoubtedly *Plectoptylis fimbriosa*. The differences between the two species are given in tabulated form to facilitate comparison.

<i>Plectoptylis emoriens</i> :	<i>Plectoptylis fimbriosa</i> :
apical whorl smooth;	apical whorl ribbed;
spiral sculpture only perceptible in young specimens; suture deeply impressed; whorls $4\frac{1}{2}$ , rounded; periphery obtusely angled; fringe of fine hairs, deciduous; umbilicus moderately deep; diam., 6-7 millimetres.	strong spiral sculpture on the upper surface; suture not impressed; whorls 6, flattened; periphery acutely keeled; fringe of coarse laciniae, persistent; umbilicus very deep, perspective; diam., 13-15 millimetres.

The parietal armature is similar to that of *Plectoptylis fimbriosa*, but the palatal armature slightly differs, in the folds being much shorter, and the small tooth situated posteriorly to the sixth fold in *P. fimbriosa* is absent in *P. emoriens*, and instead of it there is a minute denticle a little above and posteriorly to the second fold (see fig. 50d). The specimen figured is in my collection and measures 7 millimetres in diameter. The palatal folds are visible through the shell wall.

*Plectoptylis reserata* (figs. 51a-e), from Tchen-K'eou, China, was described and figured by Mr. Heude in Part 2 of his "Notes sur les Mollusques terrestres de la Vallée du Fleuve Bleu" (1885), p. 112, t. 30, f. 3. The shell is disk-shaped, more or less pellucid with flattened spire, pale corneous, regularly and finely ribbed, decussated with very fine spiral lines above and below, widely and deeply umbilicated. It is composed of  $6\frac{1}{2}$  regularly coiled whorls, which widen slowly; the last whorl descends a little in front and is acutely keeled at the periphery, which is provided with a fringe of laciniae. The peristome is white, a little thickened and reflexed. The aperture is roundly lunate, the margins being united by a raised flexuous ridge on the parietal callus, a

little notched above and below at the junctions. The parietal armature consists of a strong vertical lunate plate, strongly deflected posteriorly downwards; on its anterior side are found two slight, short, horizontal folds in a line with the upper and lower extremities of the vertical fold; between these are two, or sometimes three, small denticles, elongated vertically, which in some specimens have coalesced (see fig. 51d, which shows part of the parietal wall). The palatal armature consists of a small, thin, horizontal fold near the suture; next four stouter and longer horizontal folds united by a slight vertical callus, and at equal distances from each other; and finally another thin, short, horizontal fold near the lower suture (see fig. 51e, which shows the inside of the outer wall). *Plectoptylis reserata* is closely allied to *P. laminifera* (see ante, vol. iii., p. 205, fig. 30). It differs, however, in being more pellucid and less solid, in the whorls being flatter and in the umbilicus being much more shallow. The parietal armature displays considerable differences; the vertical plate is much more oblique downwards, and the upper and lower anterior folds are much thinner and shorter, while

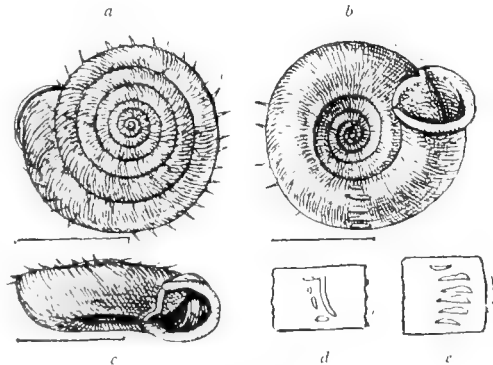

Fig. 51.—*Plectoptylis reserata*.

there are two or more denticles elongated vertically between these two folds, whereas in *P. laminifera* there is only one denticle, elongated horizontally, and this is sometimes absent. The specimen figured is from Patong, and is in the collection of Mr. Gredler, Bozen, Austria; it measures—major diam., 13 millimetres; minor diam., 11.5 millimetres; axis, 5.5 millimetres.

(To be continued.)

THE AERONAUTICAL ANNUAL.—We have received a copy of this really interesting work for 1897 (published by W. B. Clarke and Co., of Boston, Mass., and Wesley and Son, of London. 178 pp. Price \$1.) It is well illustrated and the articles throw much light on what is being done to accomplish mechanical flight. The time was not long ago when we gazed with surprise on the electric light; possibly some of us may live to overcome our astonishment at flying omnibuses.

## CONTRIBUTIONS TO THE LIFE-HISTORIES OF PLANTS.

BY THOMAS MEEHAN.

(Continued from page 16.)

## FECUNDITY OF HELIOPHYTUM.

*HELIOPHYTUM INDICUM*, the *Heliotropium indicum* of the older botanists, has found its way over all the tropical and subtropical portions of the earth. It is at home in Asia, Africa and America, and if it once gets a chance seed into the soil of Europe, will no doubt as easily maintain its hold as other free-seeding typical weeds have done. In some unknown way a few plants appeared in 1894 in my garden (Philadelphia), and have afforded me an interesting study. Its capacity for seed production is enormous. The cyme-branches that have flowered and have, or will have, perfect seed, represent, August 28th, a line of 1,224 inches. There are twenty seed vessels, that is to say forty seeds to the inch, making a total of 46,960 seeds. The cymes are still vigorously unfolding and flowering, and will probably double these figures, but in uncertainties it is best to be on the safe side; so, allowing but one-third more, we have a length of fruiting rachis of 1,632 inches, and a total seed production of 65,280.

All this has proceeded from a plant that was itself but a seed three months before! The total length of stem and branches supporting these seed-bearing cymes is but 396 inches. The plant is true to the classical story of Clytie and Phoebus which gave the original genus *Heliotropium* its name. It does not open a flower until the sun has reached the summer solstice. When the sun ceases to woo it, the flower opens, only to find its beloved going away. Less than three months of flowering will, therefore, have been occupied in this enormous seed production.

The facts here detailed have an important bearing on two points maintained by me in connection with the life-history of plants.

I have recorded numerous observations in the "Proceedings" of the Philadelphia Academy, commencing with 1866, showing that the growth-energy of plants is rhythmic, dependent on the power of the plant, or the parts thereof, to convert nutrition into the growth-force, and that the various forms which plants present are the result of varying phases of life-energy, in most cases of no physiological value, and with which environment has little to do. The evidence furnished by *Heliophytum*, though of a negative character, is surely strong! Through the long ages the plant has been established over a vast area, and consequently subjected

to many varying and varied conditions of environment, it has continued as a compact genus or section distinct from *Heliotropium*, without any material change that would warrant a modern botanist in making a new species of it.

Again, it has been maintained by me that as environment can have no important influence on changes of form, the free and untrammelled production of seed would be of far more importance in a supposed "struggle for life" than any power of adaptation could be that depended more on an occasional cross for its increased energy. Dean Swift's satire, in which the Lilliputians by the mere force of numbers are made to overcome the giant Brobdingnagians, cannot be supported in every case by the histories of plants; but when it comes to a question of distribution, numbers surely are the more likely to hold the field.

I think I may claim the credit of advancing the further proposition that a free production of seed may always be taken as an *a priori* indication of self-fertilization. In cleistogamic flowers the certainty of seed-bearing is well known. With rare exceptions the huge natural order of Compositae are self-fertilizers, and they have managed to embrace within themselves about one-tenth of the whole vegetable kingdom. Where the wind or an insect is the agent in fertilization, the agent does not always come along. On plants dependent on this outside assistance, numerous flowers fail to seed. No plant so dependent ever perfects all its seeds; in many cases utter failure follows. In this remarkable plant there is no indication that a single flower failed to mature seed. It must certainly be held remarkable that in a single plant, bearing in round numbers over 30,000 flowers, every one should bear two seeds.

It has been contended that, though plants may generally self-fertilize when the agents for cross-fertilization do not attend, they are so arranged as to cross-fertilize when the agent does appear. As the *Heliophytum* flowers are freely visited at times on my grounds by insects, and especially butterflies, there might be some strength in the point. I can, however, testify by an almost daily observation of my plant through the season, that minute flowers are only visited by insects when others are scarce. Though I have seen them visiting the flowers for several successive days, there are many days when they do not visit them, and none were noticed on the former until the beginning of August. A careful watching of the anthers shows, however, the extreme

difficulty of effecting cross-fertilization. The anthers form a cone over the stigma, and the pollen sacs burst almost simultaneously with the unplaiting of the corolla. When the flower is a few hours old the stigma protrudes slightly through the anther-cap, and is visible under a lens through the very small orifice of the corolla-tube. Even admitting that the flower has not fertilized at this early stage, and that the tongue of a butterfly might introduce foreign pollen to it under certain circumstances, it would rarely, in any case, occur. It is well known that all insects soon discover the easiest method of doing their work. In this case there are five openings between the tube of the corolla and the bases of the filaments, offering a wholly unobstructed course to the creature's tongue. It would have to use considerable force to insert its tongue under the anthers pressing down on the stigma. It is inconceivable that the flower can receive any aid to cross-fertilization in this way. But we may grant that a cross-fertilization will result in a plant better fitted for the struggle for life than one self-fertilized, and that a small percentage might become cross-fertilized. The question of numbers again forces itself upon us. How many of the seeds of any plant get a chance to develop to a plant again bearing seeds? How many of the 65,280 seeds of this plant will probably mature—will come to be seed-bearing plants next year? Only a small percentage, in any case, ever do. In this case surely very few will, and of these how many would those resulting from a "chance cross" give?

Facts of this character are common, but this case presents them in such a remarkable degree as to make it a special one. *Heliophyllum indicum*, a self-fertilizer and wonderfully productive, has maintained a remarkable homogeneity amidst rare variation in the environmental conditions.

#### RHYTHMIC ENERGY IN PLANTS.

If we accept the thought frequently thrown out in these contributions, that form results from the various degrees of rhythmic energy in the plant itself, just as it would in the formation of the frost crystals on a window-pane, we can see that environment cannot be regarded as a leading agent, but must take a minor place.

During the past season I was able to add a new illustration to the list in *Pentstemon barbatus*. In a large bed with several hundred flower-stems, I collected some twenty erect flowers. In the normal condition the three lower segments constitute a lip, and are so tightly recurved that they press against the tube; the upper two are erect and form an upper lip. But in the exceptional flowers noted, this is all changed. The lobes of the corolla are equal, recurved, and pressed against the tube. But the most remarkable change occurs in the fifth or barren stamen. In the normal

form this is so differently constructed from the other four that thoughtful observation has to be given before deciding that it is a stamen at all. In these erect, regular flowers there is not the slightest difference between any of the stamens. The fifth is the exact counterpart of the other four. Each one of the five stamens are alternate with the five regular lobes, as they should be in any well-ordered regular flower. Assuredly if a plant always had flowers like these, and only these flowers, it would not be a *Pentstemon*, but be made to constitute a wholly different genus, if it were not, indeed, referred to another natural order, for a two-lipped and more or less irregular corolla is regarded as a characteristic in Scrophulariaceae.

We may say that nothing but a different degree of growth-energy, accelerating or retarding the spiral development, so that that which should have been left curved was advanced to (or left in) a straight condition, had anything to do with the remarkable change.

Then we may ask if such remarkably distinct forms can be produced on the same plant and in an exceptional way, what is to prevent the plant from regularly exercising the same force, and thus making the irregular flower the exception? That this can be done is shown in the case of the upright and nodding lilies already cited, though we have no evidence that a regular and irregular lily ever grew on the same plant as here produced by a *Pentstemon*. Examples might be found if looked for.

That these vagaries, once brought into existence, have hereditary powers is too well known to horticulturists to need more than a passing notice. That they are not oftener the parents of a line of new species is probably owing to the fact that of the millions of seeds produced by a single plant, an extremely small percentage ever get the opportunity to grow and again develop to a seed-bearing condition. There would be little chance among so many for these exceptional flowers of *Pentstemon* to perpetuate themselves.

Though it would seem that in this case environment, as it is generally understood, could have had little to do in developing an irregular to a regular flower, one may plead for life-energy as the chief factor in the production of form and still leave considerable work for environment to do. One cannot well retain as erect a position when holding an umbrella against a driving storm, as if he were simply shading himself on a calm summer day; and there must be some opposing elements or adverse circumstances capable of depressing life-energy as a mechanical force, and with this variation in degree we may reasonably look for a change in form. But granting all this it must be evident that life-energy, dependent on varying phases of nutrition, is the main power in deciding form.

(To be continued.)

## SOUTH-EASTERN UNION OF SCIENTIFIC SOCIETIES.

THE Annual Congress, the first indeed, of the recently-formed Union of Scientific Societies of South-Eastern England, was successfully held at Tunbridge Wells on May 21st and 22nd. Like its inception and establishment, this success of the Union's meeting is to be chiefly attributed to the energy and tact of Mr. George Abbott, the well-known medical practitioner of Tunbridge Wells. The Congress was well attended by delegates from the various societies constituting the Union, and was presided over by the Rev. T. R. R. Stebbing, F.R.S., also of that town. The public proceedings commenced on Friday afternoon with a meeting of the delegates held in the Town Hall, when Mr. Stebbing delivered his presidential address. After pointing out that of all the societies which had been invited to join the Union, those which had associated were almost exclusively natural history societies, the President proceeded to compare the standing of natural history in the estimation of the general public now and one hundred and fifty years ago. He also referred to the difference of knowledge of "science" then and now. He gave a sketch of the progress of that type of learning through the century and a-half, including reviews of the work of the fathers of natural science, such as Buffon, Linnæus, John Hutton, William Smith, Cuvier, Darwin, and many others. Continuing his comparison, the President reminded his audience of the other changes which have come over civilization largely during those times. He said: "Carry back your minds to the almost unthinkable time when printing was unknown, when there was no Post Office and no freedom of the press, when paper was costly, and when men had to do their travelling without railways and steamers. You will see that under those conditions naturalists were almost as helpless as monkeys and other sagacious animals which are kept at a low level of civilization, because their means of communicating and keeping on record bright and improving ideas were so extremely imperfect."

After speaking of the early and even later difficulties the teachers of science have had to contend against, he pointed out the work being done by the British Association for the Advancement of Science, and the work in a lesser degree possible for the Union, of which the Rev. Mr. Stebbing was, when speaking, the first President. The following quotations are taken from his speech:

"It is commonly supposed that the advance of science has been greatly hindered by the persistent and often recurring opposition of theologians. That may be true of the middle ages, but of the

last century and our own it is extremely doubtful. The new views on the age of the earth, on the antiquity of man, on the transmutation of species severally in their turn aroused, it is true, the most violent hostility. The evidence adduced crashed in among accepted beliefs like the bomb of a nihilist. Denunciation and ridicule were freely employed against the new opinions. The 'conspiracy of silence' was adopted wherever it could be made effective. The social discouragements, which we all more or less unconsciously apply to those whose opinions we dislike, were no doubt brought to bear as remorselessly as ever upon the happiness and prosperity of many outspoken geologists and evolutionists. But the very fierceness of the controversies helped to arouse attention and keep it awake. Besides, the age was an age in which freedom had found her voice, and the country in which the controversy began was the sworn lover of freedom. Hence it came about that geology, the science which deals not in warm life and lovely colours, but in mud and stones and bones and old refuse, obtained a predominance and a publicity which it could not otherwise easily have secured. Persons of candid mind would naturally wish to hear both sides of an exciting question. Persons of pre-occupied mind would still sometimes wish to see for themselves what nonsense the geologists were writing. Of course it was foolish of them, for if a man has made up what he calls his mind, he ought never to hear the other side. Anyhow, through wisdom or through folly, by degrees the light of truth was enabled to penetrate some of the darkest corners of prejudice, and the process still continues.

"For truth to win any lasting and valuable victory, it is essential that contradictory opinions should be brought face to face. Facts so opposed that they cannot be true together should be confronted one with another, and the antagonism of each to each made manifest and expressly declared. Now, the men of science, with rare exception, make no claim from the scientific point of view to know what goes on in Heaven or in Hades; but, as I understand the matter, they are modestly certain that our globe has lasted for hundreds of thousands of years; that within the human period the whole of its surface has never been submerged at once; that no human being ever lived to the age of nine hundred years; that the human species began quite otherwise than with an abruptly created pair; that no woman was ever formed of a rib taken from the side of a man; that no serpent ever spoke with human voice to tempt a woman, or for any other purpose; that no warrior, however noble or sacred his cause, ever stayed for a single instant the cosmical motion of earth, or moon, or sun; that the rainbow has exhibited the colours of the solar spectrum to living eyes capable of perceiving them in absolute independence of any terrestrial inundation, past or future; and that the diversity of human languages, due to causes still in operation, has been the result of gradual divergence, not of any sudden supernatural intervention. But again, as I understand the matter, a large body of our pastors and masters, of men



who have a prescriptive right and a splendid vantage ground for teaching morality and religion, deny in these respects what the men of science affirm, and affirm what they deny, or else they ignore the matter, or else they are ignorant of the points in dispute and take no interest in them. But the fact is that no one can stop the revolution of the earth by simply saying that it does not move, and no teacher can influence his disciples if in his argument he presupposes as accepted and impregnable truth what they rightly or wrongly regard as incredible legends.

"If opposition has promoted the knowledge of nature, much more must the innumerable societies established expressly for its promotion have been efficacious. The growing appreciation of science led to their being founded. Their foundation has led to an ever-extending growth in the appreciation of science. Much the same may be said of periodical scientific literature, although that is a subject almost too mountainous, too labyrinthine, to enter upon just now. For my immediate purpose it may suffice to speak of the British Association. It was founded, as most of you know, in 1831. It is a missionary organization, a peripatetic school of philosophers. While most societies are like ordinary vegetables, rooted in the soil, this has the superior characteristic of an animal, as being capable of free movement. It can fit from Aberdeen to Oxford, from Glasgow to Plymouth, and from Plymouth to Dublin. It can wing its way from Liverpool to Toronto, from Toronto to Bristol, and then, leaving "The Queen of the West," pitch its camp, as we confidently expect, the year after next, in Dover. It has brought the wonders and surprises of advancing knowledge to men's own doors. It beats the drum outside their windows, so that they cannot altogether shut their ears to the music. The reception of it entails upon the hospitable town an astonishing amount of trouble and expense. Nevertheless, the welcome it receives is not only everywhere extremely cordial, but the pleasant sight is witnessed of rival towns or cities competing for the honour of giving it entertainment. What this parent association does on an Imperial scale, our Union hopes to do, for a limited area, not by inopportune mimicry, but by judicious following of a great example.

"That the British Association is broken up into sections, designated by the letters of the alphabet, from A to K, is due to the enormous extension of modern science, which makes division of labour a matter not of choice but of necessity. Each section is an association in itself. Each is fully, and sometimes more than fully, occupied with its committees and reports, and papers and discussions and recommendations. Our own energetic honorary secretary, Dr. Abbott, has printed on the back of your tickets a list of thirteen departments of scientific investigation in which he invites you to take an active part for the benefit of our Union and Congress. He does not pretend that the list is exhaustive, and in fact he does not mention either bryology, or embryology, or bryozoology, he has omitted mycology, and malacology and carcinology, he has steered clear of morphology, and physiology and seismology, of zoogeography, and phytogeography and crystallography. He says nothing about plankton, or nekton, or benthos; and he saves his credit, as I must do mine, by alluding to all the rest as 'allied subjects.' This at least is patent, that of subjects there is no dearth, but no one can any longer hope to be a specialist in all of

them or in many. To know everything about something, or something about everything, is becoming increasingly difficult.

"More I shall forbear to tell you anent the wisdom and the profit of all that we wish to do and to do not; remembering how even the eager and enquiring Queen of Sheba, on her visit to the Hebrew Linnæus, was so tired out with all that she heard and saw that there was no more spirit in her. Only to timid and hesitating beginners I may venture to say one concluding word. Believe me, that ever as you pursue your path through the fairyland of science and become more and more acquainted with the riches and splendour of the scene, you will more and more be convinced that the fame of it has not exceeded the reality, that at your outsetting the half was not told you."

The Rev. J. Scargill, B.A., of the Bromley Society, read a paper upon the "Preservation of Local Fauna and Flora." It contained a summary of the means now obtaining, which tended to their destruction, and Mr. A. Rose followed with "Suggestions for protection against the wasteful collection of specimens," and urged the various societies of the Union to assist in its discouragement. An important and useful discussion was inaugurated by Mr. Atwood, on "How can the Technical Education Grant assist Local Societies?" In his paper Mr. Atwood drew attention to the advantage many local and more or less struggling scientific societies would gain if a meeting-place free of rent could be given in some of the numerous technical educational institutions which were being now founded with public money, under the auspices of County Councils. He instanced the case of his own society and

"other unaided organizations, which had, in the survival of the fittest, stimulated a taste for intellectual enjoyment. Many of these bodies would have survived or done a greater work if they had not been so hampered by want of funds, in which the rent of premises was always the most serious item. Sometimes local men of means would foster the institution, but more often it suffered from inanition. Where these societies existed the technical fund was usually in full force, helping technical institutions which were springing up. The scientific societies cast longing eyes that it might catch some of the crumbs which fell from the public feast of knowledge. But they were told that private societies could not benefit from public funds. They might arrange for payment and so find a home in a public library, which otherwise would be beyond them. But, alas, the Kent County Council heard of the arrangement and put its foot down on it, and the poor natural history society was frustrated in finding a local habitation even when it had the sympathy of the District Council. Surely the local authority could better judge than the County Executive whether the society was worthy of support or should be hastened toward that bourne whence no society ever returned. He could find nothing in the statute to show that it was an infringement to give the local society shelter, but if the legal acumen of the County Council found in the Act what others could not, he respectfully suggested the Act should be amended. The school-room or other building in which the society might

meet was inconvenient compared with the institute, which should be its natural home, and would extend its usefulness. It would be to the reciprocal advantage of the local authority, the society and the public generally. He was sure that were the concession granted it would not be found misplaced."

In the discussion which followed, Mr. J. W. Tutt, F.E.S., of London, made a vigorous speech in favour of the proposal. He said :

"The question was, how would the Technical Education Grant assist local societies? He feared that direct assistance was at present impossible, but if sufficiently strong representations were made he thought they might have some indirect help, and if they could not claim a share of the public fund, he did not see why they could not find a home under the roof of the institutes which were being built. He quoted the Acts which governed the expenditure of the funds by the local and county authorities, and pointed out that the first requisite of a money grant was to give technical instruction, and without a teaching staff no institution was eligible for aid. It might be granted that these societies were educational agencies, but it could not be shown that its instruction was methodical, and the Department would not recognise them as entitled to a grant, nor could their work be termed purely technical. The definition of the Act did not cover their societies from the industrial point of view. He could understand where a scientific society was an outcome of a science school the Act might be strained to provide it with a museum, but as a rule the members did not come under the category of teacher and pupil. The distinct intention of the Act was that the institutions receiving grants should be schools. Some of them might have hoped it was possible to obtain a money grant, but although this appeared impossible, there were ways by which they might be indirectly aided, as by the use of the institute rooms for their meetings. Until recently, branches of natural history work were almost entirely carried on by isolated amateurs, who had built up their observations to an exact science, and therefore the amateurs and their work deserved some consideration. He pointed out how ignorant agriculturalists were of entomology, and the information which was open to them. A man pursuing some original investigation did not need the class text-book, as he was following the true mode of education, and learning how to think himself instead of following the system which the Department miscalled education. Many students of the institutes made little practical use of what they were taught, and those most successful at examinations were usually failures at original observation. The original observer did not want to be treated as a youth in a grant-earning class, and it was rather absurd to refuse to help the source of knowledge when making a grant to the diluted work in the class. It was not to be expected that the average county councillor would understand the broad aspects of the educational question. Their natural history society had no boys and girls pegging away at set lessons, and therefore the county councillor said the society could have no claim on them. But there were men like Sir John Lubbock, whom their Congress might approach, and get a ruling from the Government as to the legality of the action of the County Council in shutting the societies out of the public institutions. One of the greatest troubles of their

societies was to find a home, and when their members could work in co-operation more valuable work could be done. He regarded their societies as the fountain-head of knowledge, from which the class teachers learnt from books and imparted to their scholars. Whence had the facts in the textbooks been obtained but from the member of the learned society whose observations were published? Did not work like this deserve State recognition? Small societies with a permanent abode would have more money to publish their transactions, and more valuable papers would see the light. The poorer man with scientific tastes could only belong to the local society, and their existence was sufficient to prove their necessity. The action of the Kent County Council came as a rude shock, but one could not understand the county councillor who accepted unintelligently what he was told by his constituents that they did not pay money for a lot of lazy fellows to poke about in chalk-pits, or the prejudice of an official who jumped at the conclusion that the natural history society was a private institution, when all its observations were for the benefit of the world. They had a strong claim to be housed in public buildings, but it ought not to be left to official opinion whether they were entitled to this accommodation or not. He pointed out that the Canadian Government recognised private research, and made a grant for the purpose. That was what our colonies were doing, while the authorities at home were refusing even the use of a room. They did not ask the State to publish papers as Colonial Governments were doing, but they asked that public buildings erected for science, and which were the index of the advance of the nation, should be open to their use."

Dr. Abbott moved a resolution, requesting the County Councils of the district to assist in the work of general culture through the medium of these societies. He hoped that more cordial co-operation might be brought about.

The Chairman suggested that the matter should be referred to the Council meeting for discussion, and this was agreed to, and the following resolution was unanimously carried :

"That it be an instruction to the Executive Council to consider the question of how far buildings erected under or used for the purpose of the Technical Education Act may be used for the purposes of local scientific societies, and to take such action in the matter as they may think proper."

Among other papers read at the Congress were: "Local Museums," by Mr. W. Cole, F.L.S.; "Committees of Field Clubs," by Professor Boulger, F.L.S.; "A Geological Section near Tunbridge Wells," by Professor Seeley, F.R.S.; and "The Search for Coal in Kent," by Mr. H. E. Turner.

On the Friday evening the Mayor invited the members of the Congress to a conversazione at the Town Hall, which was well attended. Exhibits of scientific interest were numerous, and lantern lectures were given. On Saturday afternoon excursions in the neighbourhood were made, including one devoted to geological rambles in the district, which were fortunately favoured with fine weather. After luncheon at Mount Ephraim Hotel, the party was conducted to Boyne Park, to inspect the sand

formation in the excavations, and thence to the rocks on the common. The party then assembled at King Charles' Church to join Professor Seeley's Field Class, and view the cuttings in the new athletic ground, which were the subject of one of the papers. Returning for tea at Messrs. Parker's, of The Pantiles, a drive was made to the High Rocks, returning *via* Rusthall Common, where the

Toad Rock was inspected. The excursion was enjoyed by a numerous party, and concluded a most enjoyable congress.

Professor Boulger, F.L.S., F.G.S., was invited to become President for next year, and accepted the office. An invitation was received to hold the next annual Congress at Croydon, which was accepted.  
J. T. C.

## THANET SANDS.

BY GEORGE BARHAM.

I FIND to-day, on looking through the index supplied with the May number of SCIENCE-GOSSIP, that an ample apology is due from me not only to its Editor, but also to Mr. E. A. Martin, of Thornton Heath. Should any new readers fail to comprehend my meaning, I would refer them to SCIENCE-GOSSIP, N.S., Vol. iii., p. 54, in the volume just completed. There, will be found a communication by the gentleman mentioned above. To this I replied with notes, to be found on p. 129, I find that in the next month's number, p. 149, Mr. Martin has made a courteous, but somewhat debatable answer to me. I have been very busy, and also have changed my residence, and with fear and trembling I admit that several of my copies of SCIENCE-GOSSIP are lying unopened and unread. Amongst these I find the number containing my friend's remarks.

The main issue seems to turn, in Mr. Martin's mind, upon Bishopstone Dell. In my idea it does not, but applies to the whole north-east Kent coast, from Faversham to Reculvers. I claim that this stretch of land is, and has been, since pleistocene times, gradually sinking. Mr. Martin suggests rising. Here I would say that it is evident the land there has risen since its original deposition, but that is not the point. What has it been doing since the Bishopstone Dell "stream" carved out its alleged mighty channel? In other words, every land, or portion of land, has been *see-sawing* up and down since its deposit. The question is as to the last direction of this movement.

Speaking of this neighbourhood, I said, "It is fairly proved that the land hereabouts has been eaten by the sea." Mr. Martin asks (p. 149), "Where is this proof?" I am a little surprised at a geologist asking this question in face of the cliffs which confront him on the very place in point. There are the cliffs, crumbling at every storm. Giant masses of Thanet sand lie scattered on the beach. Out at sea are banks of sand—such as the Girdler, Spaniard, etc., and I am

asked for a proof as to the land being eaten. Or take it from the point of view of antiquarian research. The Church of St. Mary—Reculver Towers, as it is generally called—stood in Roman times some three or more miles from the sea. To-day it is protected from the fury of the waves by a stone embankment, built, I believe, by the authorities of Trinity House. Bishopstone Dell is about three miles along the coast, towards Herne Bay. This watering-place presents the same features of crumbling cliffs, this time of more tenacious London clay. Hampton, further on, shows the same bold outline; Swalecliffe has to be protected by rows of faggots, driven at the base of its cliffs. The "Priest and Sons" is the name given to-day to a part of Tankerton cliffs near where once a public-house of that name stood. To-day it is at the bottom of the ocean. Tankerton cliffs, just opposite the "Street," show the same signs, but since the "Street" came, the beach has filled up here, and these cliffs are now protected. Once they were eaten away as fast as those have been at Reculvers. At the end of the "Street" stood a Roman pottery works. I will here admit that many claim that a Roman vessel bearing pottery as a cargo was wrecked there. I do not mind much which theory is adopted, although I consider the first more feasible. If the pottery stood then the land has gone, as Tankerton cliffs tells us. If the vessel was wrecked in a place where there is ample water to-day, then the land has sunk. For these "pots," which have been recovered by the thousand, are whole, beautifully glazed, and with even the delicate lips and handles intact. So many have been found that the sea-bottom there is still called the "Pudding Pan." Hence they have been subject to no tossing or grinding action by the sea. If a vessel was wrecked nothing but the gently running aground could have destroyed her without breaking up her fragile cargo. But the pottery idea is, as I have said, most feasible. The place where these are found is more than four miles out at sea. It should be admitted by anyone that the land has, from the evidence, therefore been destroyed

and eaten by the sea. Possibly Mr. Martin will admit that in face of this one fact the sinking land theory is more tenable than the rising; for a rising land would have shallowed the sea, raised up protecting banks of sand, and shown signs similar to those in places where land-rising is indisputable, as on the south-east coast of Kent.

Again, between the Isle of Sheppey and Graveney lie Graveney Marshes. Mr. Martin and our editor will, I hope, excuse me for seeming prolix; but these places are bound up in the question, as will be seen by reference to any map. Once, not many years ago, figuratively speaking, this was dry land between the two points, intersected by the then tiny Swale. Proof is, that a few feet down lies firm London clay. Then as the land sunk, the sea came in further and swamped gradually the land, hence the name "marshes." Man's ingenuity has drained and banked them by sea walls. The proof of all this lies there, as I shall mention later. What is it to-day between the island and the mainland? A shallow estuary, one might almost call it, in which the tide runs out for miles, where lie great sands through which ships thread a precarious passage. A curious phenomenon is this; the land sinking, and consequently the sea deepening; and the sea itself hindering its work by silting up, through its own eddies, its deepening bed.

Now let Mr. Martin put on dredger's boots, and, armed with a spade, wander out at low tide as far as he can and dig. He will first find shingle, gravel and sand, washed from down the coast, interspersed with Thanet sand blocks and septaria from the London clay. Beneath these he will find a loamy soil containing teeth and bones of horse and ox, and occasionally a portion of soaked, crumbling British pottery. Amongst this he will also come across calcined oyster and cockle shells, shells of the *Unio* or river mussel, and occasional wood ashes.

Yet this is sea bottom to-day. Is more proof wanted? Then let him search at this low-tide level a little more, and he will find, possibly, some ghastly and gruesome relics of the "Lost Churches of Seasalter," which, with foundations sapped by the encroaching sea, fell into ruin and decay, and now lie buried under the ocean wave. A fragmentary human pelvis was once in my possession, and proved this.

To return, I ask Mr. Martin again to explain how the rising of the land would assist in cutting out that gully at Bishopsteal? I claim, first, that there never was watershed there—in recent times, at least—enough to give a large supply of water; secondly, to have cut out a gully which in the length of a quarter of a mile attains a depth of fifty feet coupled with a not inconsiderable

width, and knowing that this same stream must at least have continued another three miles during the last thousand years or so, presumably cutting out at the same rate, a stream would be necessary which would combine the minuteness of a mountain torrent with the force of a Niagara; thirdly, my memory may be here at fault, for it is nine years or more since I saw the place, but I fancy the bed of the stream curves away inland in a direction leading towards Herne Bay. I do not remember clearly, and only speak here for the sake of knowledge, and Mr. Martin may correct me. The bed of such a stream as that mentioned above, cutting through rock of the softness of Thanet Sands, should be as straight as an arrow. Is it? I believe not. Again, such a stream would, meeting with the Thames and Medway currents, have raised a considerable "bar," which it has not.

The only explanation of Bishopstone Dell fully coincident with the facts, general features and history of the neighbourhood, is that thereabouts occurs a fault, or fissure in the Thanet Beds, of which advantage has been taken by the drainings of a scanty rainfall. There are no river terraces, or ancient banks of the sides of the dell. In its bottom there is next to no alluvial deposit. There is no evidence that it was cut out by water. Presumption is all on the other side.

Now, as regards Hampton, Mr. Martin is mistaken when he says there are no cliffs to speak of. I am alluding to a depression almost a quarter of a mile wide existing between Hampton cliffs (average height at least fifty feet) and Swalecliff (with average height of forty-three feet). This depression is, as I have said, an ancient river bed. In it are found mammoth and also hippopotamus and rhinoceros remains; apparently nothing else. The banks of this "bed" are exposed, they run up the London Clay and overlie it to the height (from sea level) of twelve feet; and at the centre meanders a tiny stream. "Apparently plain proof" say those of the land-rising theory; but they say this simply because observation is lacking. There are the remains, or beds, of two streams there. The older one, of plain river sand and its giant mammal remains, showing traces of a rising land. The second, and later, a shingle bed, cutting through the faint strata of the older one, containing no sand, but bones of domestic animals, and fragments of Roman and Romano-British pottery. A hiatus of fifty thousand years. This newer stream has constantly tried to widen its bed—conclusive proof of land sinking. Had the land risen, the tendency would have been to narrow and deepen it. In fact, so growing has been its tendency that it has been banked and filled with a miniature lock-gate.

No, one is forced to admit, I think, that the

land of the north-east Kent coast is steadily sinking, as well as disappearing, through the encroachments of the sea. In years to come, Herne Bay and Reculvers, if left to themselves, would be destroyed, and to compensate for this, the untiring sea would give us dry land between Sheppey

and the "Marshes," that is, unless the land sunk more quickly than was compensated for by the ballast removed from the first-mentioned places.

18, Chilwell Street, Nottingham;  
June, 1897.

## FOREIGN VARIETIES OF BRITISH LAND AND FRESHWATER MOLLUSCA.

BY T. D. A. COCKERELL.

(Continued from Vol. iii., page 262)

THE parts of this list will not be given in systematic order, but in such order as convenience dictates. It is to be hoped that some of the readers will be able to offer criticisms and additions to the several parts, which no doubt the Editor will be glad to publish.

### SUCCINEA.

There is much useful work to be done among the British members of the genus *Succinea*, especially in observing the variations in the soft parts and the anatomical differences.

*SUCCINEA PUTRIS*, L. Westerlund, in 1885, thus classified the forms we commonly refer to *putris*.

(1) *S. putris*, L. Form, *minuscula*, Baud. Scarcely 8 mm. long. France.

a. Longish forms with normal, or drawn-out spire.

*v. olivula*, Baud. France, England, Germany, etc.

*v. bavaria*, Cl. Bavaria.

*v. limnoidea*, Pic. France, Russia, England, etc. *S. acuta*, Pfr., is probably a synonym.

*v. clessiniana*, Haz. Red-brown or reddish-yellow. Whorls, 4. Hungary.

*f. gotlandica*, West. 27 mm. long. Gotland I.

*v. grandis*, Haz. 25-27 by 13 mm.; whorls, 4. Hungary, France, Germany.

*v. angusta*, Haz. Hungary, Italy.

*f. sequanica*, Bgt. 14 by 7 mm. France. It is to be remarked here that *sequanica* dates from 1877, and so should properly stand for the variety (to include *angusta*), since Hazay's variety was published in 1880.

*v. fitzgeraldiana*, Haz. Reddish-yellow. 16 by 8 mm. Whorls, 4. England, Switzerland.

*v. westerlundiana*, Haz. 21 by 10 mm. Hungary.

*v. firma*, West. Above, whitish; beneath, amber colour. 16-17 by 9-10 mm.; whorls, 4. Briakowskij Island, Siberia, in 70° 39' N lat.

*v. hazayana*, West. Reddish-yellow. 19½-22 by 9-10 mm.; whorls, 4-4½. Tunguska, Siberia, in 61° N. lat.

*f. angusta*, Baud. France.

*f. extensa*, Baud. France

b. Globose forms with shortened spire.

*v. charpentieri*, D. and M. Thin-shelled; spire very short; 15 by 10 mm. England, France, Sweden, etc.

*v. subglobosa*, Pascal. Thin-shelled; mouth large; 17-18 by 9 mm. England, France, Sweden

*f. drouetia*, Moq. Clear yellow. France, Sweden.

*v. globuloidea*, Cl. Small; broad-oval. Germany, England.

*v. fontana*, Haz. 20 by 10 mm. Hungary.

*v. ferrusina*, Moq. Clear yellow. France, England, etc.

*f. vitracea*, Paul. 12 by 7 mm. Sardinia, etc.

*v. milneedwardsi*, Bgt. Yellowish-olive; 15 by 11 mm.; mouth 11 by 6 mm. France.

*f. xantheleæ*, Bgt. Small; whorls, 2 or 3. Probably a juvenile.

*v. trianfracta*, Da C. (1778). Broad-oval, greyish-yellow; 15-16 by 9-10 mm.; mouth 11 by 6 mm.; mouth broad-oval; whorls, 3½-4, rounded. England, Denmark, Sweden, Hungary.

*v. temporalis*, West. Long-oval; thin-shelled; 16-17 by 8-9 mm.; mouth 11-12 mm. long. Ronneby, Sweden.

*v. charpyi*, Baud. Spire short, conic; whorls convex; mouth long-oval. France, England, etc.

*v. hians*, Baud. Mouth very large, 11 by 5½-6 mm. France.

*v. parva*, Haz. 18 mm. long. Hungary. Rem.-Kob. Icon., f. 2051.

(2) *S. parvula*, Pascal. 8-11 by 6-7 mm.; mouth 6½-7½ mm. long. France, Italy, Sweden, England, Germany. *S. suecica*, Cless., is a synonym.

*v. aberrata*, Paul. MS., West. Mouth long-oval; length of shell, 7-7½ mm.; of mouth, 5-5½. Italy.

(3) *S. stagnalis*, Gass. France.

*f. jeffreysi*, Baud. Mouth large, 8-10 by 4-5 mm. Cumberland, England. Westerlund considers *S. putris* v. *vitrea*, Jeff., to be the same.

In the above list I include the British as well as foreign varieties; the additional foreign varieties of *S. putris*, not given in Westerlund's revision are *v. perfecta* (Haz.), Cless., Hungary (this and the next are in Westerlund's supplement, 1890); *v. radiata*, C. G. West., Sweden; *v. carnea*, Moq.; *v. bravida*, Moq.; *v. webbia*, Moq.; *v. studeria*, Moq.; *v. pulchella*, Moq.; *v. opaca*, Moq.; *v. curta*, Colb.; *v. nigrolimbata*, Colb.; *v. rubens*, Baud.; *v. alba*, Baud.; *v. scalaroides*, Baud.; also *typus*, Baudon.

Mesilla, New Mexico, U.S.A.  
April 11th, 1897.

## NOVEL BOTANICAL COMPETITION.

THE Editor of SCIENCE-GOSSIP is of opinion that a novel and interesting botanical competition may be founded, which will provide not only much amusement for the competitors and for the readers of this journal, but also valuable scientific records of the growth and habits of plants not generally recognized.

It is therefore decided that two prizes be offered by SCIENCE-GOSSIP under the following rules:

THE FIRST PRIZE is to be one or more books on any subject, at the selection of the winner, up to the published value of £2 10s.

THE SECOND PRIZE will be of a like character, valued at £1 10s.

- (1) That there shall be at least ten competitors.
- (2) That the names and addresses of competitors shall be sent in before October 1st, 1897.
- (3) That the competition shall apply to photographs of uncommon, local, or rare plants.
- (4) That three pictures be taken of the plants while growing: (a) Best showing the habit of growth when flowering, fruit, or otherwise; (b) of the growing plant and its immediate surroundings; (c) of the near landscape to show the character of the plant's station.
- (5) That any sized picture up to, though not exceeding, half plate will be acceptable for competition; quarter plate size will be preferred, but will not influence the prize.
- (6) That the Editor have the right to reproduce any of the competing pictures in SCIENCE-GOSSIP or elsewhere. The negatives to be the property of the competitor.
- (7) The locality of the habitat or station of the plant sent for competition must be given; but not necessarily for publication, if good reason is given.
- (8) That one or more dried specimens from the same locality must accompany the photographs of the plants for confirmation of identity.
- (9) That the competitor supply, if required by the Editor on reproducing in print any of the competing pictures, notes on the habits, growth, flowering, range of local distribution, and other facts which may be of interest to botanists and general readers.
- (10) That any kind of plants are available for the competition, and may include ferns, mosses, fungi, marine algæ, etc.
- (11) That all the pictures for the competition are to be delivered, in duplicate and unmounted, at the office of SCIENCE-GOSSIP not later than October 25th, 1897.

The judging of the pictures will be by the Editor of SCIENCE-GOSSIP, whose decision will be final.

He will, however, invite the co-operation of our botanist referee and two leading photographers, whose names will be duly announced.

The chief points to be considered will be (a) the variety of the species photographed; (b) the grasp of detail, such as the natural position, the flowering parts, and other surrounding, in case any appear; (c) the excellence of the photography.

The name and address of the competitor must be neatly written in lead pencil on the back of each competing picture. One competitor may send three or less subjects for competition, each being available for competition on its own merits.

The awards of prizes will be announced as soon as practicable after the 1st of November next, probably in the December number of SCIENCE-GOSSIP. It is intended to reproduce the prize pictures in SCIENCE-GOSSIP. All the competing photographs will be circulated for examination among the competitors during the winter months.

We sincerely hope that we may receive the support of all classes of botanists in this competition, which is founded solely in the interests of an extended culture of field botany in this country.

J. T. C.

## LOCAL SCIENTIFIC SOCIETIES

AND THE TECHNICAL EDUCATION GRANT.

WIDESPREAD attention should be called to the agitation commenced at the meeting of the South-Eastern Union of Scientific Societies, reported on page 41 in this number. The demand is for participation in the Technical Education Grant, as administered by the County Councils, to the extent of house-room for meetings, libraries, etc., free of rent. This is now denied, as the societies do not examine pupils. It could be easily given, with hardly any tax on the finances of the Department. Local scientific societies largely consist of the very class the Grant was made to benefit. These amateurs are, as a body, doing an immense amount of educational and civilizing work, in spreading knowledge of the highest class. At present their work is heavily taxed by the annual rent-charge for meeting-places; indeed, it too frequently swamps their existence. If, however, every local society of scientific amateurs would petition their Members of Parliament to get the *right*, on possessing a certain numerical strength, to ask the County Council for room, we feel sure it would be granted by Parliament. We also doubt not that, if properly approached, Sir John Lubbock, M.P., F.R.S., would advise and manage the business in the House of Commons. With his powerful aid little opposition need be feared, especially when we remember that the Prime Minister is himself a scientific amateur of the greatest culture.

J. T. C.

## A TAME BLACKBIRD.

BY R. WELCH.

I SEND you a photograph of a wild female blackbird which has nested under such exceptional circumstances that her picture on the nest may interest your readers. The pair of birds were familiar with the garden at Oakleigh, Belfast, and had been in the habit of entering the little fernery in which they nested on a narrow shelf. This building is only about eight feet long by six feet wide. As shown in the photograph, the nest was placed between a flower-pot and a creeping plant. It was most difficult to make a good picture because the operations had to be conducted in such a narrow space, that is to say,

## EARLY MAN IN EGYPT.

BY P. AND F. WHITEWAY.

YEAR by year the soil of Egypt surrenders some of its secrets, but never before have such important discoveries been made relating to the earliest traces of man in the land of the Nile as those of Professor Petrie, whose sojourn in that country during the past few years has been productive of such splendid results.

In 1894 Professor Petrie spent eleven weeks at Koptos, now represented by Kufit, about thirty miles north of Thebes. The ancient town of Koptos formed the Nile termination of the world's oldest trading-route. The road which passes through the valley of Hammamat to the shores of



A TAME BLACKBIRD.

within three feet of the nest. I had, unfortunately, only a large full-plate camera with me, and this had to be erected and focussed inside the fernery. My proceedings did not seem to trouble the bird at all, for she allowed me to take exposures of twenty seconds, all the while sitting perfectly still. The long exposures were in consequence of the late time of day, as it was after six o'clock in the evening. I therefore had to take advantage of her confiding nature to stop down the lens to  $f/16$  in order to get such sharpness into the picture as was possible. It is common for some birds to nest close to the habitations of man, but we seldom hear of a blackbird's nest in such an exposed position.

19, Londale Street, Belfast; June 25th, 1897

the Red Sea is even to-day frequented by numerous caravans, trading in goods of all descriptions. Tradition had always pointed to Koptos as being one of the first settlements formed by the Egyptian emigrants when they arrived from their ancient home in the sacred land of Punt, in southern Arabia. The site of the temple of Koptos was thoroughly cleared, and no less than six successive temples were found, one built over the other, ranging from the most prehistoric age to the period of the Ptolemys.

Hitherto Egyptian art and civilization have presented a striking paradox. The farther back we go the better the art, the more simple and yet perfectly developed the social life. Beyond the

age of Seneferu, the last king of the third dynasty, and builder of the Pyramid of Medum, there was no trace of a beginning. Now all this is changed. In the lowest strata of the temple at Koptos, our explorer discovered remains, which for the first time reveal to us prehistoric Egypt, namely, three rude statues, fourteen feet in height, of extremely rough workmanship, representing the human form. The arms, legs, whiskers and ears are merely indicated by hammered outlines, no chisel marks are visible. These figures are evidently the first statues of Khem, the God of Reproduction, erected shortly after the foundation of the first settlement. On each is sculptured the leather thong girdle, still in use among the Egyptians of the present day. Each figure also shows some curious designs. One represents the jagged protuberance with which the Red Sea sawfish is armed. A second is a picture of the shells found along the Red Sea coast; while other designs of elephants and hyenas, running down hills in pursuit of young calves, are easily distinguishable.

Professor Petrie's discoveries of more recent years are quite as important as those mentioned above, for he has brought to light traces of an entirely new people. Through the district, thirty miles above Thebes, beyond the cultivated land, runs the old bed of gravel laid down by the Nile, when it filled the valley. This extends about three miles to the foot of the cliffs. Above it rise the limestone mountains which formed the old shores of the Nile, bordering the great plateau through which the Nile Valley is cut. On the top of this plateau, 1,400 feet above the river, the home of palæolithic (early stone age) man was discovered. Here were found large beautifully-worked flints, perfectly unworn, of similar types to those discovered in the river gravels of France and England. Besides these, other flints of a later palæolithic type were found embedded in the ancient gravels of the former high Nile. So that the Nile still rolled down as a vast torrent, fifty times its present volume, at the latter age of palæolithic man.

In close proximity to these cliffs the site of a town was discovered, so extraordinary were its contents that if it had been found in Syria or in Persia no one would have supposed it to be connected with Egypt. Not only was a town discovered, but also a series of cemeteries consisting of nearly 2,000 graves belonging to this same new race. During the work of excavation every object discovered was noted in position and marked, to facilitate future research. In this great number of graves not a single Egyptian object was found—not even a scarab, hieroglyph, amulet, or piece of Egyptian pottery. Not one body was mummified or buried at full length; all were contracted, with

the knees bent up to the arms, the head invariably being to the south and the face to the west. A few years ago Professor Petrie, while excavating at Medum, found some similar burials; in fact they are not unknown even in such widely separated countries as Great Britain and the Pacific Islands.

It can now be definitely said that these people existed between the seventh and ninth dynasties, or about 3,560 B.C., and probably were the race who overthrew Egyptian civilization at the close of the old empire (dynasties first to sixth) and so produced the dark age of the seventh to the tenth dynasties. The physiognomy of this new people was fine and powerful, without any trace of negro prognathism. Some were over six feet high. The great development of their legs points to their having been a hill race. Hair found on the skulls shows that it was brown and wavy, but not at all crisp like that of negro races. A very prominent nose and a long pointed beard gave a strong resemblance to the Lybian and Amorite type depicted on the monuments. A remarkable and extremely repulsive custom was the eating of portions of the bodies of deceased persons. In the graves the head is always severed from the shoulders and the hands often removed. In some tombs pottery was found placed over the decapitated head, in others the severance had gone further and the bones were all grouped, in one place a handful of ribs, in another a number of arm bones and elsewhere a pile of vertebræ; and a still more decided case in which the skulls were placed between stone vases, lines of bones strewn round the pit, like the spokes of a wheel, each with the ends broken off and the marrow scooped out—all these point to ceremonial cannibalism.

In many ways, however, in pottery, flint-working and bead-making, this race was equal or superior to the Egyptians. No writing was known beyond personal marks; drawing and sculpture were in a very rude condition. Metal was well-known; copper adzes show that woodwork was familiar, traces of a finely-carved bed frame, with bulls' feet, was found. Copper needles show that sewn garments were worn. The making of stone vases was a favourite craft, many beautifully-formed specimens having been discovered, from soft alabaster to the hardest syenite, from six to eighty unearthed from each tomb.

This new and unexpected discovery seems to show us that the veil which enshrouds many obscure points in the pages of Egyptian history will shortly be drawn aside, more especially from before the blank spaces of unrecorded facts which exist between the sixth and tenth, and thirteenth to seventeenth dynasties, and the land of the Nile will offer up more marvels to the world at large.



## GREENWICH OBSERVATORY.

SATURDAY, June 5th, 1897, was the day for the annual visitation of Greenwich Observatory, when a goodly company, together with the official Board of Visitors, attended. The Astronomer-Royal's report stated that the north wing and central dome of the Physical Observatory was completed in September, last. This building contains the largest telescope in the world devoted to photography, presented by Sir Henry Thompson. On the same equatorial stand, of the German pattern, but constructed by Sir H. Grubb, is at the one end of the declination axis, the 26-inch photographic telescope, with the 12 $\frac{3}{4}$ -inch Merz telescope, formerly mounted as the great equatoreal, mounted as the finder below it, whilst above it is the 9-inch Thompson photo-heliograph. At the other end of the axis is a 30-inch Cassegrain reflecting telescope to which is attached the photographic spectroscope, whilst the 6-inch Hodgson telescope is attached as a guiding telescope. This instrument was a great centre of attraction. Amongst other visitors was Sir Henry Thompson himself. Just outside this dome, upon the terrace roof, is mounted the Dallmeyer photo-heliograph, with which photographs of the sun have been taken on 222 days, 471 negatives being retained for preservation, as well as twelve with double images of the sun for determination of the zero of the position-angle. These photographs, together with those taken in India and the Mauritius, give a series on 360 days out of 366. Many of these photographs, together with the apparatus for their measurement, and also some photographs of the moon, one plate of Saturn and one of Jupiter, were on view in a sort of museum below, under the charge of Mr. E. W. Maunder.

The new Altazimuth was supposed to be ready in September last, but its four reading microscopes gave discordant results, varying according to the last position of the telescope. Examination showed that the axis was too weak; this was strengthened, but the fault was not wholly done away with, even though the position of the friction rollers was altered, and a system of levers substituted for springs. Mr. Simms has, however, discovered an unsuspected source of error in the transit circle, of similar construction, made for the Perth Observatory. Owing to the method of giving a helical twist to the grinder in grinding the pivots, it was found that these had a tendency to act as screws, introducing a longitudinal force varying in direction according to which way the telescope was moved; the effect being to slightly move the iron standards carrying the bearings and microscopes, and varying the position of the latter with respect to the graduated circles. A few circular turns of the tool cured the Perth instrument, and as the Greenwich one suffered from the same complaint, similar treatment was adopted, and it is confidently hoped that the instrument will shortly be in working order.

Last year, as in previous years, the sun, moon, planets and fundamental stars have been regularly observed at the meridian with the transit circle. The annual catalogue of stars observed in 1896 contains 3,454 stars. With the 13-inch astrographic equatoreal, on 117 nights, 348 plates were taken, though, for various reasons, sixty-nine of them had to be rejected. These photographic maps of the heavens, many of which were on view, were very fine. As a result of the Astrographic Congress meeting at Paris in June, 1897, it was resolved not

only to measure the plates face upwards, but to reverse them and go over them again, so doubling the work, but at the same time increasing its accuracy. The entire work is expected to be completed in nine years, at the present rate of progress.

With the 28-inch equatoreal, 195 double stars have been measured, each on an average on two nights, and the satellite of Neptune on four nights. By reversing the crown lens of the objective, it has been proved to be an efficient photographic instrument, excellent photographs of the moon and close double stars having been obtained.

The glass ball used hitherto as a sunshine recorder has been found to give results latterly much shorter for Greenwich than the instrument in Bunhill Row. Since January 1st another glass ball has been mounted close to it, and the records of the two show differences equal to nine hours for January, and as much as 21.7 hours for March. The reason of the falling-off of the older instrument is supposed to be due to some change in the glass.

The total number of chronometers and deck watches received at Greenwich for rating was 1,220, those issued, 1,124, and 519 were sent for repair. Ninety-seven chronometers were entered for the trial for twenty-nine weeks in temperatures varying from 42° to 107°, and the Admiralty purchased fifty-four of them for the Navy.

On five days the Greenwich time-ball was not raised owing to the wind, and that at Deal on ten days for the same reason. On thirty-one days the automatic signals from the clock at Westminster failed. On one occasion the error of this clock amounted to four seconds, but on fifty-five per cent of the days of observation it did not exceed one second.

The mean declination of the magnet for the year was 16° 56.5' west. No great magnetic disturbances were recorded during the year.

The mean temperature of the year 1896 was 50.1°, being 0.7° above the average. The rainfall for the year ending April 30th, 1897, was 26.83 inches, 2.29 inches above the fifty years' average. During the same period the mean daily horizontal movement of the air was 289 miles, which is eight miles above the average of the preceding twenty-nine years.

F. C. DENNETT.

## THE PHOTOSCOPE.

A MATEUR photographers, especially ladies, who do not care to be burthened with heavy camera and attendant tripods, have offered to them this season valuable prizes for an interesting competition. It has been organized by Messrs. Ross and Co., of 111, New Bond Street, London, for the two best series of twelve negatives taken by their new photoscope, or field-glasses and camera combined. The conditions of the competition are simple, and open to all owners of the Ross instrument, competitors having to state from whom it was purchased. The twelve negatives must be accompanied by prints made by any printing process and mounted. The winning series to become the property of the prize-givers. The first prize is valued at £10, being a best quality field-glass, suitable for either out-door observation or theatre, fitted with photoscope attachment; the second prize is a fine pair of binocular glasses for field work or theatre. The negatives and prints must be delivered to Messrs. Ross and Co. before 30th September next.

The Ross Photoscope is an elaboration of the

Sanders patent, which has been much improved and developed by the present manufacturers. It consists in outward appearance of an ordinary



THE PHOTOSCOPE. Fig. 1.

first-class pair of field-glasses and may be used for all purposes required of those instruments. When the user requires to take a picture the photographic attachment (fig. 2, A) is added to the small ends of

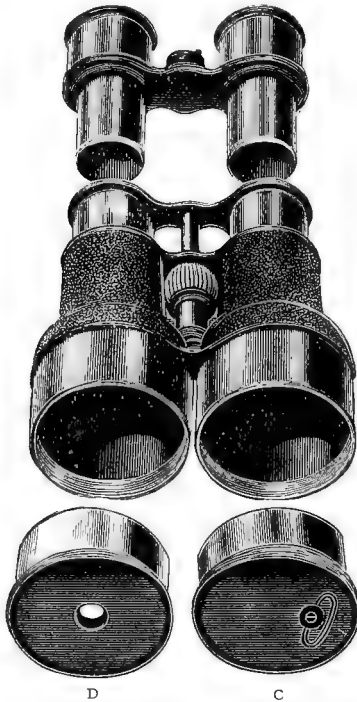

THE PHOTOSCOPE. Fig. 2.

the binocular body (B). This attachment (A) combines the lens, shutter and finder. The operation is simplicity itself, for it is only necessary to remove the ordinary eyeheads and slide the tubes of the

attachment into the tubes of the binocular. The roll-holder (c) contains a spool of film and is screwed into the larger end of the tube, which has the lens and shutter in its opposite end, the focussing-glass (D) being fitted into the outer tube, as shown in fig. 2. The whole packs away into an ordinary portable sling case. When operating the picture the glasses are reversed to the eyes (fig. 1). The resultant pictures are charming little photographs, of

which we reproduce some examples, they may be enlarged to any reasonable size. Messrs. Ross and Co. have thus produced an instrument which

combines a first-class field or opera-glass with a means of carrying a camera that will give us permanent records of the incidents of travel or of nature notes we may desire to record.

The photoscope will do all that may be expected of the hand camera, with the advantage that positions may be worked in which no other instrument would be available. As the photoscope is held to the eyes whilst the

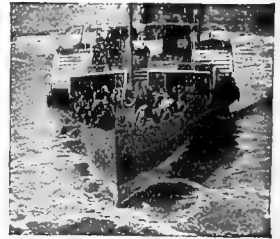

picture is taken, a more natural position is the result. Each roll of films, to be used as negatives, contains sufficient for twenty-four exposures, the pictures measuring  $1\frac{1}{2}$  inch by  $1\frac{3}{8}$  inch square, the price being one shilling and sixpence for each roll. These are very portable, and may be developed and printed at leisure. For those persons who have not

opportunity themselves, Messrs. Ross and Co. charge two shillings per spool of films for developing, and from one shilling and sixpence to two shillings per dozen for printing the pictures. There are few students of nature who would not find the photoscope useful for one or other purpose in connection with the permanent records of their investigations.

The price of the photoscope varies from £7 10s. to £10 10s. For those who have already valuable binocular field-glasses, arrangements may be made for fitting them with the attachments for photography.





CONDUCTED BY FRANK C. DENNETT.

		Rises.		Sets.		Position at Noon.	
		h.m.	h.m.	h.m.	h.m.	R.A.	Dec.
Sun	July 6	3.53 a.m.	5.16 p.m.	7.3	22° 39' N.		
	16	4.4	8.8	7.44	21° 18'		
	26	4.17	7.56	7.54	19° 20'		
		Rises.		Sets.		Position at Noon.	
		h.m.	h.m.	h.m.	h.m.	R.A.	Dec.
Moon	July 6	11.19 a.m.	5.7 p.m.	10.39 p.m.			
	16	9.16 p.m.	1.45 a.m.	6.44 a.m.			
	26	0.29 a.m.	9.24	6.16 p.m.			
		Souths.		Semi Diameter.		Position at Noon.	
		h. m.	h. m.	h. m.	h. m.	R.A.	Dec.
Mercury	July 6	11.22 a.m.	2° 7'	6.16	25° 39' N.		
	16	0.10 p.m.	2° 5'	7.45	22° 44'		
	26	0.54	2° 6'	9.12	17° 58'		
Venus	July 6	8.51 a.m.	12° 1'	3.55	16° 39' N.		
	16	8.52	10° 8'	4.50	18° 38'		
	26	8.56	9° 8'	5.13	20° 13'		
Mars	July 6	3.6 p.m.	2° 1'	10.5	12° 59' N.		
	16	2.50	2° 1'	10.28	10° 43'		
	26	2.33	2° 0'	10.51	8° 20'		
Jupiter	16	3.4	14° 9'	10.42	9° 19' N.		
Saturn	16	7.50	8° 2'	15.30	16° 47' S.		
Uranus	16	7.52	1° 9'	15.31	18° 51' S.		
Neptune	16	9.41 a.m.	1° 2'	5.22	21° 50' N.		

MOON'S PHASES.

	h.m.		h.m.
1st Qr.	July 7 ... 1.32 p.m.	Full	July 14 ... 4.52 a.m.
3rd Qr.	" 21 ... 3.8	New	" 29 ... 3.58 p.m.

In perigee, distant 226,200 miles July 11th, 6 p.m.; in apogee, July 23rd, 3 p.m., distant 251,500 miles.

OCCULTATIONS AND NEAR APPROACHES:

July.	Star.	Magni- tude.	Dis- appears.	Angle from Vertex.	Re- appears.	Angle from Vertex.
12	B.A.C. 6194	4.7	7.5 p.m.	66°	8.38 p.m.	337°
22	ε Arietis	4.6	2.47 a.m.	19°		Near approach.
24	17 Tauris	3.8	0.17 a.m.	91°	1.10 a.m.	309°
24	23 "	4.2	0.56 a.m.	161°	1.33 a.m.	245°
24	20 "	4.0	1.15 a.m.	23°		Near approach.
24	7 "	3.0	1.23 a.m.	140°	2.15 a.m.	267°
24	27 "	3.8	2.33 a.m.	204°		Near approach.

CONJUNCTIONS OF PLANETS WITH THE MOON:

July 4	Mars*	2 a.m.	planet 3° 21' N.
4	Jupiter†	8 p.m.	" 4° 11' N.
10	Saturn†	9 a.m.	" 7° 18' N.
25	Venus*	8 p.m.	" 6° 44' S.
31	Mercury*	1 a.m.	" 3° 18' N.

\* Below horizon in England. † Daylight.

An annular eclipse of the sun occurs in the afternoon of July 29th. It is, however, quite invisible in these islands, the line of central eclipse passing across Mexico and the West Indies. It begins in the Pacific Ocean and ends in the South Atlantic.

SUN.—We are evidently near the minimum of sun spots. No dark spots were recorded on May 12th to 18th inclusive. On July 2nd, at 4 a.m., the sun is in apogee, or farthest from the earth.

MERCURY is not in a favourable position for observation, being in superior conjunction with the sun at 10 p.m. on 15th.

VENUS is a splendid object in the early mornings, rising about 1.25 on 1st and about 1 a.m. on 31st, reaching greatest elongation west, 45° 38', at 12 p.m. on 7th. On 23rd, at 2 a.m., Venus is in conjunction with Ceres, the first discovered of the minor

planets. Venus is only 6' north, and so will be in the same telescopic field. When in conjunction with Neptune at 9 p.m. on 28th she will be unfortunately below the horizon.

MARS sets at 10.32 p.m. on 1st and 9.5 on 31st. Mars is in conjunction with, 8' south of, Jupiter at 3 p.m. on 25th.

JUPITER sets at 10.50 p.m. on 1st and at 9.1 p.m. on 31st, so, like Mars, is fast passing from the observer's ken.

SATURN sets at 1.30 a.m. on 1st and at 11.26 p.m. on 31st, being near the meridian at the beginning of the month, when he first peeps through the twilight.

URANUS is a little to south of Saturn, and Neptune is too near the sun for observation.

METEORS may be looked for July 11th, 20th, 21st, and especially 25th to 30th.

RED STARS IN POSITION DURING JULY.

	R.A.	Dec.	Magnitude.
R Secum	18.41	5° 51' S.	4.7-8.5
B 505 Saggittarii	19.27	16° 38' S.	6.5
B.A.C. 7,001 Cygni	20.15	38° 38' N.	7.0
B 502 Draconis	19.26	76° 20' N.	6.5
R. Lyrae	18.52	43° 48' N.	4.3-4.6
B.526 Saggittarii	20.0	27° 34' S.	7.5

Variable(?) stars are indicated by ...

THE Central Bureau for Astronomical Telegrams has the address "Astronomische Centralstelle, Kiel," Professor H. Kreutz having now taken the work in hand.

THE NEXT GREAT SOLAR ECLIPSE.—Professor Naegamvala, on May 26th, gave an interesting account, to the British Astronomical Association, of the preparations being made in India for the observation of this phenomenon.

THE Magnetic Observatory at Greenwich will shortly be removed from within the boundaries of the Royal Observatory to another part of Greenwich Park, where a site has been selected. This removal has become necessary owing to the disturbance to the instruments caused by the amount of iron in the New Physical Observatory and also the great reservoir of the Kent Waterworks, south of the Observatory.

THE Yerkes Telescope is at last in working order, and it is to be hoped that, in the hands of Professor Barnard and Burnham, it will prove even more efficient than the great Lick instrument.

THE LICK AND GREENWICH EQUATORIALS.—According to the "English Mechanic," the excellence of the object-glasses of these two instruments is such that they are found in practice to separate double stars closer than theory assigns as the limit of their dividing power. This speaks volumes for the instrument makers. We may add that the Greenwich 28-inch should by theory just divide stars 0.163" apart, whilst 0.127" would be the limit of the 36-inch Lick. The similar limit of the 41.5-inch Yerkes glass should be 0.110".

HUMPHERY BARKER CHAMBERLAIN. — Mr. Chamberlain was born in Manchester in 1849, and as a boy of seven went to America. At Denver, Colorado, he founded a noble observatory bearing his name, containing amongst other valuable instruments a 20-inch equatorial. He returned to this country seven years since, and has died in consequence of a bicycle accident. It was only on May 28th last that "Engineering" gave a fully-illustrated description of the observatory



CONTRIBUTED BY FLORA WINSTONE.

ANNAES DE SCIENCIAS NATURAES. (Oporto, April, 1897.) The Editor, Signor Augusto Nobre, continues a paper upon the "Marine Animal Life of the Coasts of Portugal." Dr. Lopes Vieira contributes a "Catalogue of the Fishes of Portugal." There was, he states, no registered list of the modern collection of fishes of Portugal in the Museum of Zoology of the University of Coimbra, and on these he founds his paper. "Notes on the Birds of Portugal" are continued by Mr. W. C. Tait, and include, in this number, among others, the genera *Tringa*, *Totanus*, *Sterna*, *Larus* and *Puffinus*. The article on the "Molluscs and Brachiopods of Portugal," by the Editor, is also continued, the genera *Clathrella*, *Raphitoma*, *Haedropleura* and *Halia* being noted, as are the native members of the families Cancellaridae, Marginellidae, Volutidae, Mitridae, Fasciolaridae, and Buccinidae.

LA FEUILLE DES JEUNES NATURALISTES. (Paris, June, 1897.) M. Eugene Simon continues his revision of the genera of Trochilides, or humming-birds, dealing in this number with *Aphantophroa*, *Talaphorus*, *Patagona*, *Leugippus*, *Polyerrata*, *Uranomitra*, and others. M. G. Budde-Lund writes on the oldest civilization in the world, being extracts from a lecture given before the Students' Association at Copenhagen. He says that one must look to bees, ants and termites to find the first civilization of any animals on the earth. They were living in communities with regular systems and laws when man, if in existence, was only a savage beast. "The most subtle explanations," says M. G. Budde-Lund, "have been put forth to maintain the supremacy of the human reason above 'instinct,' but one becomes more and more convinced that the only difference is in degree." The article on the French shores of the Channel is continued by M. Adrien Dolfus, the subject in this number being the molluscs found between Bénéville and Dives, including the genera *Cultellus*, *Mactra*, *Tellina*, *Limaea*, *Purpura*, *Natica*, etc. M. G. de Rocquigny Adanson has a note on the distribution of the orange-splashed brimstone butterfly (*Rhodocera cleopatra*). This form belongs chiefly to the fauna of southern France, and is not seen further north than the 46th parallel.

VICTORIAN NATURALIST. (Melbourne, May, 1897.) Among other communications is a paper read before the Field Naturalists' Club of Victoria, in March, 1897, by Mr. A. J. Campbell, describing the nests and eggs of three rare birds, viz.: *Edoliisoma tenuirostre* (Jardine's caterpillar-eater), *Ptilopus swainsoni* (red-crowned fruit-pigeon), and *Megaloprepia magnifica* (purple-breasted fruit-pigeon). Mr. E. Anderson and Mr. F. P. Spry give an illustrated account of a new butterfly, *Lycana cyrilus*. This species was apparently first obtained in Victoria some years ago by Mr. J. Kershaw, who had in his collection a female specimen, taken at Moe. Messrs. Anderson and Spry were fortunate enough to obtain a series of this species,

both male, and they were captured in December, 1896, near Cranbourne. Mr. Henry Tisdall writes of "A Botanical Peep into the Rocky Pools of Sorrento and Queenscliffe." The paper is devoted to remarks on the algae to be found in these pools, especial attention being given to the genus *Caulerpa* and other low forms.

ACADEMY OF NATURAL SCIENCES. (Philadelphia, May, 1897; pp. 197-228.) The most important Paper in this section of the Proceedings is by Samuel N. Rhodes, being "A Contribution to the Mammalogy of Central Pennsylvania." It is a fortunate thing for posterity that records of the wild animals of various sections of the northern Continent of America are now from time to time catalogued, with intelligent notes upon their respective abundance or rarity. The march of civilization is so steady and so relentless that the feral mammal fauna is necessarily much altered in the course of comparatively few years. The district considered by Mr. Rhodes is of a mountainous character, and includes hills upwards of 2,000 feet in altitude, with numerous valleys, rivers and woodlands of the Alleghenies. Owing to deforesting and burning of much of the timber of the region, not only the animals but the flora has changed to a great extent during the last century. Most of the larger animals have consequently disappeared. The last American bison was killed in central Pennsylvania so long ago as the year 1800, by Colonel John Kelly, five miles from Louisburg. The wapiti (*Cervus canadensis*) was fairly abundant in the first decade of this century. The last known wapiti or "elk" is stated to have been killed in Elk County by a party of Indians in 1865, though one is said to have been seen a couple of years later. Virginia deer have struggled on up to the present time, though they have been almost exterminated by pot-hunters, wandering dogs and forest fires. In this part of the state, wandering dogs, which have become practically wild, are "ten times as destructive as the grey wolf ever was." Other animals of interest which have disappeared include the black rat (*Mus rattus*) which was once the common rat, but has been replaced, as it has in the British Islands, by the Norway rat (*Mus decumanus*). Of course both these species were introduced, and are not native to America. The grey wolf still remains, but is wary and rare. The total list of species mentioned by Mr. Rhodes reaches sixty-one wild animals. The last number being appropriated to the North American Indian (*Homo sapiens-americanus*), of whom there were in 1890, on various reservations in the district, in more or less civilized condition, some 8,000 of various tribes; two-thirds of these being of Iriquois descent, the remainder being chiefly Senecas and Cherokees.

THE CANADIAN ENTOMOLOGIST. (London, Ont., June, 1897.) As was pointed out recently by one of our contemporaries, the Canadian fauna is being studied and described chiefly by naturalists hailing from the U.S. side of the border-line. Our Canadian friends should bestir themselves for the credit of the Dominion. In the number before us there are eight communications all written from the United States, and apparently there is not a single Canadian writer in this number. Of course the political boundary does not make any difference in the native fauna and flora of North America. Still it would be more satisfactory to see the Dominion naturalists more active. The Canadian geologists, botanists, and economic entomologists, have done well; but there are few exceptions to the lack of energy in other branches.

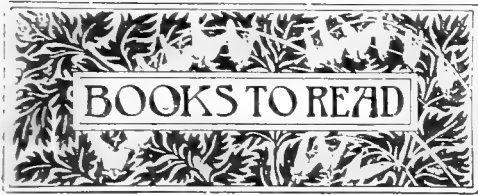

NOTICES BY JOHN T. CARRINGTON.

*Essays of George John Romanes, M.A., LL.D., F.R.S.* Edited by C. LLOYD MORGAN. 253 pp. 8vo. (London, New York and Bombay: Longmans, Green and Co., 1897.) Price 6s.

This is a new and cheaper edition of the collected essays of the late Professor Romanes. In gathering them from the pages of various magazines and reviews as few alterations as possible have been made. Nothing has been added or cut out; only evident misprints adjusted. In these Essays, as might be expected from the sources whence they come, Dr. Romanes appears in his best popular style. They are ten in number and treat of varied subjects, such as "Primitive Natural History," "Darwinian Theory of Instinct," "Man and Brute," "Mental Differences between Men and Women," "Recreation," "Hypnotism" and "The Muzzling Orders for Dogs." All are of interest, for Romanes could not be otherwise when writing for the public. There being so much variety leaves no room for disappointment, whatever be the taste of the intelligent reader.

*Practical Acoustics: Lessons in Elementary Practical Physics.* By C. L. BARNES, M.A., F.C.S. Vol. iii., part 1, "Practical Acoustics." 214 pp. 8vo, illustrated by 82 figures. (London and New York: Macmillan and Co., 1897.) Price 4s. 6d.

This book is the first part of Volume iii. of the "Elementary Practical Physics" series, begun in 1885 at Owens College, Manchester, by the late Professor Balfour Stewart and Mr. W. W. Haldane Gee. By the death of the former author, and the transference of Mr. Gee's labours elsewhere, the series fell into abeyance for some years. We have now a new work issued in the series, which still bears the names of Stewart and Gee, that is a credit to its predecessors. In it we find the study of sound directed with care and judgment, and facts of more recent discovery fully explained. Sound of nearly every kind is treated, from its simplest origin to the more obtruse and complex aspects of its phenomena. The text is plainly written for even the least initiated, who by aid of the numerous diagrams cannot fail to follow the author as he proceeds.

*The Induction Coil in Practical Work.* By LEWIS WRIGHT. 172 pp. 8vo, illustrated by 4 plates and 72 figures. (London and New York: Macmillan and Co., 1897.) Price 4s. 6d.

At first sight this book may be passed as another popular account of the Röntgen X rays; but more careful perusal will show that it is a concise account of the induction coil and a practical guide to its efficient and safe use. Now that an extended acquaintance with radiography is more common, authors have to write with great care upon all that appertains to the subject. In his treatise, Mr. Wright begins quite at the commencement, frankly confessing—as did last year he who knows more of its action than any other man, Lord Kelvin—that we know nothing of the reality of electricity. Still, of the detail of its work and its

effects under specified circumstances we here may learn much valuable information in the easiest possible manner. We are led on by the author step by step in this little book, until a very complete fund of modern knowledge of the subject may be attained. The diagrams are of recent date, and the book is well produced.

*The Concise Knowledge Natural History.* Edited by ALFRED H. MILES, 787 pp. large crown 8vo, with 530 original illustrations. (London: Hutchinson and Co., 1897.) Price 5s.

This is one of those remarkable efforts of publishers which have in modern times astonished the literary world. It is a co-operative work by Messrs. R. Lydekker, F.R.S. (Mammals, Reptiles, Amphibia, Fishes), R. Bowdler Sharpe, LL.D. (Birds), W. F. Kirby, F.L.S. (Insects), W. Garstang, M.A. (Lancelet, etc.), B. B. Woodward, F.L.S. (Mollusca), F. A. Bather, M.A. (Starfish, etc.), R. Kirkpatrick (Moss Animals), R. I. Pocock (Worms), and H. M. Bernard, M.A. (Corals and Animalcules), and the illustrations are by J. Keulemans, F. H. Micheal, Ernald W. Miles, Frank C. Aldworth, and others. A better title for the book would have been "A Concise Knowledge of Zoology," for it only deals with that department of natural history. Of course, when so much is crammed into so small a space, the conciseness becomes very apparent. One cannot expect anything more than a sketchy account of the general subject. This gets more apparent as we turn to some of the later pages; but for those who use this work for its proper purpose, as a dictionary, it is useful. For instance, refer to the excellent index, and turn to "Helix"; then refer to page 643, at the top of which stands "Snails and Slugs"; the whole of the large and important family of 'Helicidae' is dismissed in the following five lines: "The Helicidae comprise an enormous number of forms: high-spired shells, as in the genus *Bulinus*, which is confined to South America and the West Indies; or, as in the gaudily-painted shells of the Philippine genus *Helicostyla* and our own *Cochlicella*; shells with short spire, or no spire at all, as in the big genus *Helix*, of which the garden snail is an example." It is for the general naturalist, who is not a specialist, and indeed for the specialist who desires to know something of other things in nature outside his own group. The figures are seldom good, though generally sufficient; but some are so wanting in clearness of detail as to be of little use.

*The Dictionary of Photography: For the Amateur and Professional Photographer.* By E. J. WALL, F.R.P.S. Seventh edition. Revised and edited by THOMAS BOLAS, F.C.S., F.I.C. 632 pp. 8vo. Illustrated by 122 figures. (London: Hazell, Watson and Viney, Limited, 1897.) Price 7s. 6d.

In a comparatively recent science, like that of photography, we may expect numbers of new words incorporated in each new dictionary devoted to the subject. That it is so, is shown by the fact that this new edition of Wall's well-known dictionary has required 150 additional pages and about 300 new headings, with many additional diagrams, to bring it up to date. Some of the words are treated in encyclopædic style, for instance, "Portraiture" occupies sixteen pages, "Exposure," thirty pages, "Bromide Paper," eighteen pages, "Enlarging," no less than thirty-four pages. It thus becomes a work of reference for the photographer, to whom the latest edition is a necessity.

*A Text-Book of Geology.* By W. JEROME HARRISON, F.G.S. 343 pp., illustrated by 140 plates and figures. (London, Glasgow and Dublin: Blackie and Sons, Limited. 1897.) Price 3s. 6d.

This is a new edition, the fourth nominally, but really the book has to a very large extent been re-written, with many additional illustrations placed in the text. Even the type has been re-set on larger pages, with a larger and clearer fount. Much recent discovery in the science of geology has been incorporated, and the work is well up to date in its information and style of training necessary for special examination tests. Some specimen examination papers of the Science and Art Department are reprinted for the guidance of students.

This book, however, will be useful to many others than those who desire to be "crammed" with examination tests, to the exclusion of the sound grounding which helps to continue the taste for after-study. It deals with the general subject in an intelligent manner in well-arranged chapters which lead on the reader by the interest created. The first chapter is a good one, being upon the definition, object, and history of the science of geology. It contains also a carefully prepared descriptive list of a geologist's "equipment for the field"; these tools are figured. We are glad to find they are simple in character and few in number. The author further instructs the reader in their use; in fact with this little but useful book anyone may commence the study of geology and palæontology with every prospect of success. The general sections of the book are: Part I., Descriptive Geology divided into Basis of Geology; Common Geological Terms; Composition of the Principal Rocks; Disintegration and Solution; Snow and Ice Action. Part II. is devoted to Classification of Remains of Animal and Plant Life. Part III. is for Historical and Stratigraphical Geology, in which the various rock series are treated. The illustrations are well chosen, and in most instances they have been taken to illustrate this work. We reproduce a couple, by permission of Messrs. Blackie, to show the popular, though useful, style of the work, and its excellence of production. Anyone who desires to know something of the geology of his neighbourhood, with the aid of this book, should have no difficulties.

*Waste and Repair in Modern Life.* By ROBSON ROOSE, M.D., LL.D., F.R.C.P. Edin. 364 pp. 8vo. (London: John Murray. 1897.) 7s. 6d.

Dr. Roose commences his work with a quotation from Boswell's "Life of Johnson," "Why, sir, you find no man at all intellectual who is willing to leave London. No, sir; when a man is tired of London he is tired of life; for there is in London all that life can afford." We might, as an "offset" suited for these times, quote another, "For the rich man, London is a fine place in which to live. For the poor man, London is a fine place to leave." We refer, indeed, to the battle of life which is being constantly waged around us with increasing severity in this immense city. It is

really that subject and its effect on the combatants which inspires Dr. Roose's work before us. To quote from one of his earlier pages (31), "The advocates of what is popularly known as 'progress' at the present day will doubtless be surprised at learning from a distinguished American physician that the number of insane is greater in a community in proportion to the political and religious freedom of the population; that is, to the opportunity they enjoy of working out their own purposes, whether in relation to this world or the next, in the manner most agreeable to themselves." Whatever may be the case in America, it is an undoubted fact in this country that we are rapidly closing prisons and increasing our accommodation for the insane. The book under notice

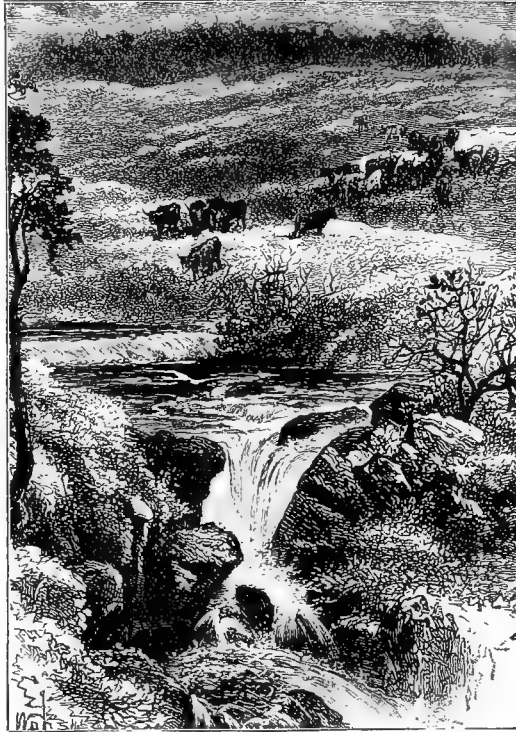

PRODUCTION OF RIVER-VALLEY BY A MOUNTAIN STREAM: A RIVER-TERRACE IS SEEN ON ONE SIDE OF THE STREAM.

(From "A Text-Book of Geology," published by Blackie and Sons.)

treats the subject of wear and tear of modern life from the hygienic point of view. If we human animals are to live unnatural lives, sacrificing physical conditions to the mental, we must take such precautions as are possible to preserve physical health, which is the keynote of mental sanity. The seven shillings and sixpence to be expended on this book will be well spent if its readers will follow its teachings, for it will save many guineas in future doctors' fees. Some of the author's best chapters are on "The Art of Prolonging Life," "Fasting and Physiology," "Infection and Disinfection" and "Health Resorts and their Uses." All his subjects are practically treated. How charming is it to read books in this type on good paper. We congratulate Mr. John Murray on its production.



*A Handbook of the Birds of Great Britain.* By R. BOWDLER SHARPE, LL.D. Vol. iv., 332 pp. 8vo, illustrated by 35 coloured plates and plain figures in letterpress. (London: Allen and Co., Limited, 1897. Allen's Naturalists' Library.) Price 6s.

This volume concludes Dr. Bowdler Sharpe's work on the birds of Great Britain for "Allen's Naturalists' Library." It contains terns, gulls, skuas, auks, petrels, shearwaters, divers, grebes, rails, coots, some others, and an Appendix with Addenda to the preceding volumes. There is also an important preface, in which the author defends his views on nomenclature as exhibited in this work. Our readers are by this time fully aware of our views on this vexed question, viz., that it

by them at the end of a field-day, if placed side by side of many a "working-man" naturalist, not only in this country but also on the Continent. This applies equally to "specimens" and to their respective knowledge in connection with habits and other facts, beyond "species" and nomenclature. Still, all this does not alter the fact that a first-class "cabinet" naturalist may produce a first-class and trustworthy book on his special subject. This is shown in the present instance. Dr. Bowdler Sharpe has given us one of our best modern popular works on British birds. The majority of his descriptions of plumage are original, taken from the birds direct. The author has been most careful on this point, which will be of great value a few centuries hence for comparison.



PT. TOR, DARTMOOR, SHOWING "WEATHERING" OF GRANITE.  
From "A Text-Book of Geology," (published by Blackie and Son.)

should be settled once for all, whatever system is adopted. In a case like this before us the subject is plain enough, because Dr. Sharpe clearly indicates what he means by giving synonyms with dates. What we object to is the use of unfamiliar names without any synonym to indicate what species the writer desires us to consider, as for instance in the "London Catalogue of British Plants." We are pleased that Dr. Sharpe has followed the British Association rules, especially in avoiding capital letters for specific names. There is much to be said for the author's defence of museum officials against the taunt of being only "cabinet" naturalists, and we agree with him as to his list of those who have done good field work; but we could point to a longer list belonging to the other side, that is of "cabinet" naturalists, who would often be confused at the different results produced

*A Hand-book of the Order Lepidoptera.* By W. F. KIRBY, F.L.S., F.Ent S. Vol v., Moths—Part iii., 344 pp. 8vo, illustrated by 32 coloured plates and numerous plain figures in letterpress. (London: Allen and Co., Ltd., 1897. Allen's Naturalists' Library.) Price 6s.

With this volume Mr. Kirby has concluded his admirable review of the Lepidoptera. We can fully appreciate his difficulty in accepting the work for Messrs. Allen and Co., and do not think he could have selected a better system of treatment than the comparison of the British butterflies and moths with their foreign relatives. His alterations of the nomenclature, as we have said in former notices, are sweeping; but, like that of Dr. Sharpe, in his "Handbook of the Birds of Great Britain," above referred to, it is intelligible on account of its excellent synonymy.



ON June 9th, a memorial bust and pedestal to Joseph Thompson, the African explorer, was unveiled at Thornhill, Dumfriesshire. A marble bust will also be placed in the rooms of the Royal Geographical Society.

WE have received Herr Oswald Weigel's catalogue of books on the zoological division Arthropoda. It contains 1,480 items of literature on insects, crustacea, spiders, etc. His address is 1, Königstrasse, Leipzig.

MR. JOHN CLAYTON has sent in a reprint of a lecture by himself on the "Effects of the Weather upon Vegetation," which is illustrated by a map and frontispiece. Botanists and agriculturists will find much to interest them in his remarks.

THE report of Dr. Copeland, the Astronomer Royal of Scotland, was issued on June 5th, as a Parliamentary paper. It deals largely with the new reduction of the right ascensions of stars, observed at Carlton-Hill, and the instruments used.

MR. EDWARD STANFORD, of Cockspur Street, London, the publisher of geographical books and maps, has sent us his useful catalogue of maps and books. This publication contains key maps both to the British and French Ordnance Survey charts. It will be found useful by our readers, who can at a moment select by number any particular sheet.

THE Annual Conversazione of the Royal Society, to which ladies were invited, took place on June 16th, and was well attended. We are not quite clear as to whether the interest of the numerous Fellows who were there was not greater in the brilliant costumes of the visitors of the "other sex," than in the many exhibits of a scientific character, as most of the latter were shown at the soirée reported in last month's SCIENCE-GOSSIP.

It is satisfactory to note that common sense prevailed at the last audit of the Urban District Council of Ampthill, Bedfordshire, when a charge was found in the accounts for the services of a "water diviner." It was conclusively shown by scientific evidence of a geological character that the spot selected by the "diviner" was one most unlikely to find water. The auditor disallowed the amount, which must be privately repaid to the Urban funds by members of the Council who voted for the "diviner's" employment.

IN the House of Lords, on May 28th, a debate of much importance to those persons possessing valuable natural history collections and other objects of a scientific character took place on the motion of Lord Stanhope. It was with the object of persuading the Government to remit death dues on such objects, and also on pictures, prints, books, manuscripts and works of art not yielding income. Lord Kelvin ably supported the motion; but nothing of a definite character resulted. The Chancellor of the Exchequer has the veto in each case which may arise, and we understand, the power to remit the dues.

It was only during the second week in June that the University of Klausenburg celebrated the hundredth birthday of its veteran Professor, Samuel Brassai; and a week later his death is announced.

MESSRS. LONGMANS will shortly publish an important revision of Sir John Evans' "Ancient Stone Implements, Weapons, and Ornaments of Great Britain." The first edition was issued in 1872, so there is much new material for additional matter.

A LARGE captive balloon, which formed part of the Jubilee fête at the Royal Botanical Society's Gardens, Regent's Park, escaped, and after ascending into a dense mass of cumulus cloud appears to have exploded. It fell in pieces in the neighbourhood of St. Pancras and King's Cross Railway Stations.

THE Annual Report of the Director-General of the Geological Survey of the United Kingdom for 1896 has been issued by H.M. Stationery Office (Price 6d.) It is fuller than usual, reaching about 100 pp. It is divided into sections: (1) Geological Survey; (2) the Palæontological Department; and (3) the Museum of Practical Geology in London.

THE terrible earthquake of June 12th, which devastated portions of Bengal, and was very severe in Assam, only too clearly shows, as has been said, that our "solid earth" is still more or less unstable, even as a mass of quivering jelly. It seems probable that the same tremor was registered by seismographic instruments at Grenoble, in France, at Newport, Isle of Wight, Edinburgh, and other European stations.

TELEGRAPHY without wires is apparently coming into practical form, and has the full support of Mr. W. H. Preece, chief of the Electrical Department of the General Post Office. The new apparatus, invented by Signor Marconi, a young Italian, is full of promise. Mr. Preece recently lectured on the subject at the Royal Institution. Signor Marconi's invention will be fully tested under the auspices of the British Government. It may lead to a revolution in signalling and telegraphy.

It is with great pleasure we note among the Jubilee honours that the editor of "Nature," Professor Joseph Norman Lockyer, F.R.S., etc., has been promoted from C.B. to a knighthood of that honourable Order. We are sure this pleasure will be shared by all our readers who know the excellent scientific work so unassumingly accomplished by Sir Norman Lockyer and of his life-long efforts to obtain Government recognition of all matters scientific. Among the other Jubilee honours, Sir Herbert Eustace Maxwell, Bart., M.P. for Wigtonshire and a popular writer on natural history subjects, becomes a Privy Councillor. Dr. Samuel Wilkes, President of the Royal College of Physicians, and Sir William MacCormac, President of the Royal College of Surgeons, are to be baronets. Professor Crookes, F.R.S., has a knighthood, as do Mr. Wolfe Barry, President of the Institute of Civil Engineers, Dr. Huggins, Dr. Thorne and Admiral Wharton, Hydrographical Department of the Navy. Dr. Edward Frankland, F.R.S., to be K.C.B., and William Henry Mahoney Christy, F.R.S. (Astronomer-Royal), to be a C.B. Sir Joseph Hooker to be G.C.S.I.



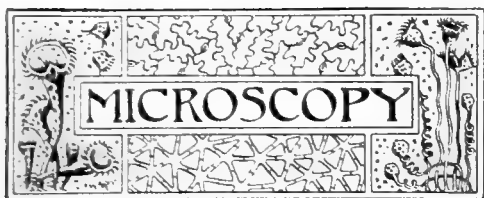

CONDUCTED BY J. H. COOKE, F.L.S., F.G.S.

[We have pleasure in announcing that Mr. J. H. Cooke, F.L.S., F.G.S., etc., has kindly undertaken to conduct "Microscopy" for SCIENCE-GOSSIP, as honorary departmental editor. Mr. Cooke is so well known in scientific circles, that it is almost unnecessary to introduce him to our readers. We may, however, remind them that Mr. Cooke edited the "Mediterranean Naturalist" for some years, and has long been a contributor to the Proceedings of the Royal Society, as also to various scientific serials. He has on three occasions received grants from the Royal Society to further his scientific work. Mr. Cooke was a Commissioner for Agriculture in the Maltese Islands, and he is now on the staff of the Science and Art Department, South Kensington, stationed at Lincoln. All communications for this department of SCIENCE-GOSSIP should be sent direct to J. H. Cooke, Esq., F.L.S., Thorndale, Lincoln.—John T. Carrington, Editor SCIENCE-GOSSIP.]

It having been decided that more space shall, in the future, be devoted to microscopy in the pages of this journal, we shall be glad to hear from all who are interested in the subject, and who may feel inclined to assist in making a success of the section of "Microscopy" in SCIENCE-GOSSIP. The monthly programme will consist of notes on current microscopical research, helpful hints and original articles, with, when possible, coloured or plain illustrations. To carry out this plan effectively, it will be necessary to have the co-operation of workers in microscopy, for it is obvious that the success of a department of this kind depends not so much on the exertions of its editor, as on the support that he receives from his readers. Copies of the Proceedings, Transactions, and Journals of English and Foreign Microscopical Societies, as well as contributions from individuals, will be gladly welcomed.—J. H. C.

**PRESERVATION OF WATER-MITES.**—The very interesting series of articles, by Dr. George, that has appeared in this periodical during the last few years has given some impetus to the study of British water-mites. The following mixture, recommended by Dr. Mark, for the preservation of these minute creatures may not be without some interest to a considerable section of our readers. Glycerine and Wickersheim's fluid, one and a half ounces of each, and distilled water, three ounces, the whole to be shaken and thoroughly mixed, and added to thirty ounces of ninety-five per cent. alcohol. The colours of the mites are apt to fade somewhat if exposed to light, the collections should therefore be kept in closed boxes.

**PETROLOGICAL SLIDES.**—Queries have been received from several readers requesting to know whether any petrological series of slides with descriptions have lately been, or are now being issued. Information on this point will be acceptable.

**THE ECONOMY OF BIRD LICE.**—From the fact that lice immediately abandon the bodies of fowls that have been affected with cholera and kindred diseases, Mr. James Weir, Jun., has been led to conclude that the office of these parasites is to prey upon the waste products of the skin as well as to freshen and beautify the feathers. They are absolutely necessary to the health and well-being of their host and are therefore to be regarded as true mutualists.

**POND-LIFE.**—The long spell of cold winds during May greatly retarded the development of both animal and plant life alike. This has been specially noticeable in our ponds and streams when, as a rule, the Entomostraca, water-mites and beetles, begin, under normal conditions, to swarm about the beginning of May. Compared with last year pond-life is, in this respect, quite a month behind. Just now the waters teem with transparent *Nitella* and *Spirogyra*, the glass-larvæ of *Covethra plumicornis*, with its peculiar kidney-shaped air-vessels fore and aft, the building-rotifer, *Melicerta ringens*, the ever-interesting *Volvox globator* and a host of others of the minute creatures so dear to the heart of the pond-hunting microscopist.

**NEW POND-SWEEP.**—The following is a very ingenious contrivance for pond-sweeping, which is at once simple in construction and effective in its working. A is the handle, B the hoop of a fisherman's landing-net. The hoop has been cut at  $a^1$ ,  $b^1$ , and a piece of copper wire stretched across. To this framework is attached a muslin net D, having a hole at its apex. E is a test-tube of about three inches in length, and one inch diameter, in the

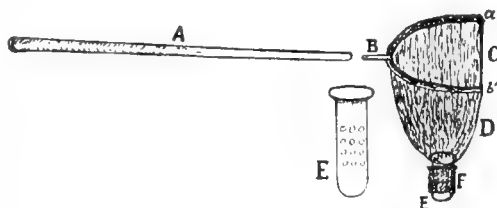

sides of which a series of clean-cut holes have been bored. Around the perforated portion of the tube a piece of fine muslin, F, is wrapped and securely fastened with small elastic bands; and the top of the test-tube is then inserted and firmly fastened in the hole which was made in the apex of the bag. The advantages of the contrivance are that the surface of the pond can be well swept, and a maximum of material may be collected with a minimum of water. How this is achieved is obvious.

**STAINING INSECTS' WINGS.**—Dr. Brodie has given much attention to the setting up and preservation of insects. The following mode of staining the wings of insects which he has devised, will be both useful and interesting. Place the whole insect in a strong alcoholic solution of fuchsin, and allow it to remain there for forty-eight hours. Then transfer the insect to water with a pair of fine forceps, and wash it until no more colour comes away, changing the water if necessary. While the washed insect floats in clear water, slip a microscope slide under it, raise the slide, holding the insect on it with a fine needle, separate the wings from the body with a fine scalpel, and remove the body. Float the wings

into position on a drop of clear water, remove excess of water with blotting-paper and allow to dry. Then place a drop of thick Canada-balsam near them and heat over a spirit-lamp. Tilt the slide to allow the liquefied balsam to flow over the wings, lower a cover-glass gently into position and allow to cool. On examination the veins will be found red, the depth of colouring varying with the length of time of staining, the thickness of the veins, etc.

**MICROSCOPICAL RESEARCH.**—The May number of the "Geological Magazine" contains two articles dealing with microscopic research. Mr. F. Chapman, F.G.S., descants "On the Microscopic Contents of a sample of Bracklesham Clay from the Solent," and Professor Rupert Jones records and figures some "New Entomostraca from Brazil."

**FORAMINIFERA.**—Students of the Foraminifera will find much of value and interest in the current number of the "Revista Italiana di Paleontologia," in which Dr. C. Fornasini summarizes the contents of several recent publications on the Rhipisopoda. Among the more noteworthy of these are "Nono contributo alla conoscenza della microfauna terriaria Italiana," "Noto micropaleontologiche" and "Foraminiferi pliocenici della provincia di Siena."

**SEEDS AS OBJECTS.**—Those who are seeking objects for slide-making purposes might be reminded that the seeds of our common garden flowers will furnish an abundance. Foxglove, mignonette, antirrhinum, petunia, larkspur, and bartonia are specially interesting and beautiful. To kill any fungi or insect ova that may be attached, the seeds should be subjected to a heat of about 200° Fah., after which they may be mounted in the usual way.

**MARINE MICROSCOPICAL LIFE.**—In the course of an address on "Marine Organisms and the Conditions of their Environment," which was recently delivered at the Royal Institution, Dr. John Murray, F.R.S., tells us that the pelagic tropical waters of the ocean teem with various forms of life of which from 70 to 80 per cent. are plants, converting, under the influences of sunlight, the inorganic constituents of sea-water into organic compounds, thus forming the original source of food of marine animals, both at the surface and at the bottom of the sea.

**SPORES OF VAUCHERIA.**—Early in May I found an alga in a cattle tank, evidently a *Vaucheria*. There were interspersed with it a number of spherical bodies, 100-110 mm. in diameter, with either one or two filaments, 30-35 mm. in diameter, running out from them, and which I take to be spores germinating. These filaments branched into larger ones, and on one of the latter, measuring 50 mm., there occurred the nearly matured "flowers" similar to those of *V. sessilis*, the oogonia measuring 50 by 70 mm. Now as the mature spores (or oospores) are usually about the same size as the oogonia and threads, the inference seems to be that plants of this genus may fructify at any stage of growth. Otherwise, how is the discrepancy between the presumably last year's spores and the new oogonia to be accounted for? Then, further, as Cooke gives 70 mm., and not 100 mm., for the size of the spores of *V. sessilis*, what species is this likely to be? Or perhaps measurements are of little use in determination. Some of your readers may be able to offer opinions.—*W. P. Hamilton, 1, Underdale Villas, Shrewsbury, June 7th, 1897.*



**RINGING MOUNTS.**—The name of mediums for ringing mounts is legion, but none gives neater or more satisfactory results than liquid shellac. Dissolve the shellac in naphtha and use without further admixture of any kind.

**MOLLUSCA IN COUNTY ANTRIM.**—Messrs. Standen and Hardy, of Owens College, Manchester, in company with Mr. Lionel E. Adams, Mr. R. Welch and Mr. Chester, of Southport, have recently been exploring the district about Ballycastle, in North Ireland, and dredging in Church Bay, Rathlin Island. The island was also examined for land and freshwater mollusca, with the result that thirty-four species were found in one day's work. They also explored Whitepark Bay, Glendun and Murlough Bay. The expedition was in continuation of one commenced in September last. It is not yet complete. The neighbourhood is a rich one for naturalists.

**MANGANESE DEPOSITS.**—In reply to Mr. McIntire's questions (*ante p. 25*), it is stated in Mr. Whitaker's "Geology of London, etc.," vol. i. 1889, p. 300, that the gravel and its associated sand may be of marine origin. This remark appears to apply to the general mass, as there is little doubt that some portions, such as that lying near the Colne at Watford, and that in the dry valley at Harpenden, were of fluvial origin. With regard to their composition, the gravels at Harpenden and No Man's Land and those of the Watford District differ considerably. The upper chalk and tertiary beds, which have been largely denuded, have supplied materials for both sets of gravels, but whilst the gravels of the Watford District contain numerous erratic blocks and pebbles, those of Harpenden and No Man's Land contain very few, so far as my own experience of them goes. In a general way, it may be said that the gravels referred to may have been laid down by similar agents, but they differ considerably in composition. I cannot say whether erratics from the Nuneaton district have been found in the boulder-clay at Bricket Wood, but boulders of chalk, sandstones and grits (apparently carboniferous), septaria (probably from the Oxford clay), and Jurassic fossils have been found. These do not seem to favour the supposition that the erratics came from a north-easterly direction. I have not yet examined the boulder-clay of Bricket Wood in any detail. I am greatly obliged to Mr. McIntire for mentioning the manganese deposit at Harpenden. The explanation given by me of the origin of the manganese deposits of the Watford and St. Alban's District I intend to put to the test as I continue the examination of the gravel deposits. During the past few weeks I have been fortunate in discovering an exposure which is by far the most interesting of the series, and tends greatly to show that the manganese, in this exposure at least, was derived wholly or in part from laminae of manganese occurring in the Upper Reading Beds.—*T. E. Lones, Rokeby Lodge, St. Alban's Road, Watford.*



Referee: THE REV. E. ADRIAN WOODRUFFE-PEACOCK, L.T.H., F.L.S., F.G.S., M.R.A. SOC., ETC.

[After full consideration, I have decided, for the present at least, to retain to myself the departmental editing of "Botany" in SCIENCE-GOSSIP, and to accept the very kind offer of the Rev. E. Adrian Woodruffe-Peacock as referee in all cases where our correspondents desire identification or advice. To the present generation of botanists Mr. Woodruffe-Peacock's name is as a household word, so well known is he, not only as one of our very best botanists, but also as an agricultural specialist on grasses and as the organising and botanical secretary of the Lincolnshire Naturalists' Union. We trust that our readers who require advice or assistance in identifying plants may send their specimens, either fresh or dried, direct to the Rev. E. A. Woodruffe-Peacock, Cadney Vicarage, Brigg, when he will answer in these columns.—John T. Carrington, Editor of SCIENCE-GOSSIP.]

**ANEMONE APPENNINA IN IRELAND.**—Mr. E. M. Dadd exhibited specimens of *Anemone appennina* from County Kildare at the meeting of the North London Natural History Society of March 11th last. [An alien.—E. A. W.-P.]

**ANEMONE APPENNINA IN ESSEX.**—At the meeting of the North London Natural History Society held on April 8th last, Miss Simmons reported that *Anemone appennina* grows in a private wood near Saffron Walden. [An alien.—E. A. W.-P.]

**ANCHUSA SEMPERVIRENS IN LINCOLNSHIRE.**—*Anchusa sempervirens*, L., has been sent from Mareham-le-Fen, Lincolnshire, by Miss Rawnley. It has been recorded once from another parish, but this is the first specimen to hand. [An alien.—E. A. W.-P.]

**TRIFOLIUM FILIFORME IN LINCOLNSHIRE.**—Mr. F. A. Lees, the well-known Yorkshire botanist, has received *Trifolium filiforme*, L., from Elkington, Lincolnshire, gathered by Mr. B. Crow. This has been recorded for the county, but no botanist of repute has ever met with it before.

**BRITISH GRASSES.**—All lovers of our native grasses should obtain Professor Edward Hackel's "The True Grasses." It is a splendid book for workers who make a special study of the order Gramineae, ably translated by Mr. F. Lawson-Scribner and Miss Elsie A. Southworth.

**VERONICA MONTANA NEAR LOUTH.**—Mr. B. Crow, of Louth, Lincolnshire, sent Mr. F. A. Lees *Veronica montana*, L., gathered in Achthorpe Wood on May 26th, 1897. This species is so rare in the county that there is no specimen in the almost perfect county herbarium housed in Lincoln Castle.

**ABNORMAL MARSH MARIGOLD.**—If Mr. J. J. Ward will turn to p. 211, vol. xxii, of "Hardwicke's Science Gossip," he will find recorded a specimen of this plant, which, from his description, seems to be identical with that found by him (*ante* p. 11). The specimen is still in my possession. Edwin E. Turner, Coggeshall, Essex; June 10th, 1897.

**FASCIATED DAISY.**—Mr. C. Greenhagh, of Middleton, Lancashire, sends us a curiously fasciated daisy. The union of peduncles in this case seems to be eight to twelve. They present a flattened riband-like form, with a single elongate-narrow fertile flowering head crowning them. It is not an uncommon anomaly.

**ORCHIDACEAE IN SURREY.**—In reference to the orchidaceous plants referred to last month (SCIENCE-GOSSIP, *ante* p. 25), I may mention that on the same day and place a friend and I found several *Ophrys muscifera* (fly orchis) just breaking into flower. A few were already expanded.—C. E. Britton, 189, Beresford Street, Camberwell, S.E.; June 2nd, 1897.

**SOLOMON'S SEAL IN HANTS.**—This elegant plant, *Polygonatum multiflorum*, is abundant in a wood on the Alresford side of Alton. About a mile down a lane from the common there is a stile entering a field-path on the right, which leads to the side of the wood, in which Solomon's seal will be found growing thick as bracken, some of the sprays being five feet in length.—John T. Carrington.

**BLUE JACOB'S LADDER IN SOMERSET.**—I picked some lovely sprays of *Polemonium caeruleum*, Lin., close to a bridge on the river Haddeo, near Dulverton, on the 13th of June, 1897. There was only one plant, but it was a very fine one with some lovely blooms on it. This plant is, I believe, a new find for Somersetshire.—F. B. Doveton, Eastcliffe, Babbacombe, Torquay. [An alien casual, often an escape from gardens, or introduced with foreign clover seed.—E. A. W.-P.]

**THE BOTANICAL EXCHANGE CLUB.**—The report of the Botanical Exchange Club of the British Islands, for 1895, is to hand. It was issued on June 5th, 1897, and it contains, as usual, a number of notes of considerable value on the different species of plants which were circulated among the members. Of the numbers of these there was a falling off, but apparently only of a temporary character; 3,056 specimens were received for distribution. Particulars as to membership may be obtained from Charles Bailey, Esq., Ashfield, Whalley Range, Manchester.

**ABNORMAL COWSLIP.**—In answer to Mr. J. C. Turner (*ante* p. 25), relative to an abnormal form of *Primula vevis* (which is, by the way, cowslip, not primrose), flowers of this genus are very subject to variation, and it is not at all uncommon for their flowers to have sepals of a leafy form, especially on being transplanted into gardens. Many specimens of this kind have come under my notice, and if Mr. Turner will refer to "Hardwicke's Science-Gossip," p. 211, vol. xxii, and p. 70, vol. xxix., he will find one or two other sports of this genus recorded.—Edwin E. Turner, Coggeshall, Essex; June 10th, 1897.

**RARE PLANTS IN LINCOLNSHIRE.**—At the meeting of the Lincolnshire Naturalists' Union at Scotton Common, on June 10th, amongst many other good species taken were *Carex elongata*, L., *Lastraca thelypteris*, Presl., *Lycopodium clavatum*, L., and *Selaginella selaginoides*, Gray, *Drosera anglica*, Huds., appears to be quite extinct and *D. intermedia*, Hayne, is very rare. *Peucedanum palustre*, Moench., has also vanished from its old spot and is as good as extinct we fear. The botanists never reached the locality from which *Carex filiformis*, L., is recorded. Mr. Sam Hudson brought a specimen of *Thalictrum collinum*, Wallr., gathered in the Isle of Axholme, near Epworth, in 1896.

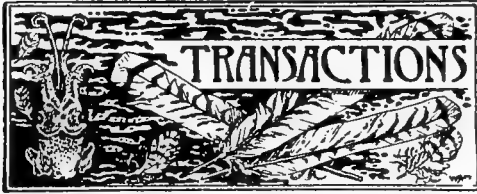

ROYAL METEOROLOGICAL SOCIETY.—The last meeting of this Society for the present session was held at the rooms of the Royal Astronomical Society, Burlington House, on the afternoon of June 16th, Mr. E. Mawley, F.R.H.S., President, in the chair. A paper by Mr. R. C. Mossman, F.R.S.E., on "The Non-instrumental Meteorology of London, 1713-1896," was read by the secretary. The author has gone through the principal meteorological registers and weather records kept in the metropolis, and in this paper discusses for a period of 167 years the notices of thunderstorms, lightning without thunder, fog, snow, hail and gales. The average number of thunderstorms is 9.7 per annum, the maximum occurring in July and the minimum in February. The average number of fogs is 24.4 and of "dense" fogs 5.8 per annum. The decadal means show that there has been a steady and uninterrupted increase of fog since 1841. The average number of days with snow is 13.6 per annum. The snowiest winter was that of 1887-88 with forty-three days, while in the winter of 1862-63 there is not a single instance of a snowfall. The mean date of first snowfall is November 9th and of last snowfall March 30th. Hail is essentially a spring phenomenon, reaching a maximum in March and April; the minimum is in July and August. The average number of days with hail is 5.9 per annum. Mr. C. Harding gave an account of the hailstorm which occurred in the south-west of London on April 27th, 1897. This accompanied a thunderstorm in which the lightning was very vivid. The hail lasted only about twenty minutes, from 6.30 to 6.50 p.m., and in that short space of time the melted hail and rain amounted to about an inch of water. The districts affected by the hail were Tooting, Balham, Streatham, Tulse Hill and Brixton. The ground was quite white with the hailstones, which in some places remained unmelted the whole of the next day. Much damage was done to fruit-trees and shrubs.

THE SOUTH LONDON ENTOMOLOGICAL AND NATURAL HISTORY SOCIETY.—June 10th, 1897, Mr. R. Adkin, F.E.S., President, in the chair. Mr. Jas. N. Smith, 28, Eastdown Park, Lewisham, was elected a member. Mr. Mansbridge exhibited a larva of *Tephrosia crepuscularia* beaten from yew, and a short series of imagines bred as a second brood from larva taken at the same place last year. He stated that the larva of *T. biundularia* from both Yorkshire and Epping were quite distinct from the larva of *T. crepuscularia* in marking and colouration. Mr. Tutt remarked that the young larvæ of both species were similar to the young larvæ of the Ennomids in being black with more or less complete white rings, but said that such similarity did not necessarily always show close relationship. Mr. Malcolm Burr, a few insects from the Island of Socotra, and said that at a casual glance the fauna seemed to represent a transition from the Palearctic to the Ethiopian region. Mr. Turner, flowers of the bogbean (*Menyanthes palustris*) and of the cinquefoil (*Potentilla comarum*) from the neighbour-

hood of Woolmer Forest. Mr. Lucas, ichneumons which had emerged this year from last year's cocoons of *Zygaena trifolii*, and also an earwig (*Chelisoches morio*) from Java, of which species two examples have recently been taken at Kew. In the discussion several curious instances of parasitism were noted. Mr. Tutt mentioned a parasite on the larva of *Melitaea aurinia*, which had three separate emergences during life of its host. Mr. Hall said that a particular ichneumon was entirely confined to the young stage of *Cucullia verbasci*. Mr. Adkin, a series of both captured and bred specimens of *Taenioctampa gothica*, from Loch Laggan. The captured examples were largely the *gothica* forms, while the latter were very typical, although the ova were from females of the former variety.—*Hy. J. Turner, Hon. Report Sec.*

NORTH LONDON NATURAL HISTORY SOCIETY.—At the meeting of March 11th last, Mr. Battley reported that he had found mistletoe growing plentifully on whitethorn and crab-apple in Ickworth Park, near Bury St. Edmunds. The paper at this meeting was by Mr. Bacot on the Liparidae, which led to an interesting discussion. One of the facts mentioned was the increasing rarity of the brown-tail moth (*Porthea chrysorrhoea*), which can hardly be attributed to over-collecting. Mr. Frost mentioned that it was common enough up to 1874.—The meeting of March 25th was well attended, and many exhibits were made. Mr. Harvey had seen a glow-worm at Chingford the previous week which was doubtless in the larval condition, that being luminous, though not so intensely so as the female imago. Mr. Woodward read a paper on the Picidae, or woodpeckers. Mr. Simes also contributed notes on the same family.—On April 8th reports of the lepidopterists were received on collecting at Sallows, near London, which seemed to have been productive of success. Mr. Dadd had taken as many as fifty *Taenioctampa miniosa* at Oxshott. Mr. R. W. Robbins opened a discussion on "The Ferns of Britain," and remarked on their style of reproduction by sori and prothallus. He then reviewed the British species. Several members followed, and made remarks of interest.—Thursday, April 22nd, 1897. Mr. C. Nicholson, F.E.S., President, in the chair. Exhibits: Mr. Battley, a fungus (locally known as the "Jew's ear"), which he believed to be edible and similar to the truffle. Miss Martin, a most interesting lot of botanical specimens, including fern prothalli; *Marchantia polymorpha* and *Lunularia vulgaris* (nat. ord., Hepaticae); *Lathroca squamaria*, the toothwort, a root parasite with thick, fleshy scales (nat. ord. Orobanchaceae), this plant, Miss Martin said, is also partly insectivorous; an aquatic species of Aroideae; flowers of the ash (*Fraxinus excelsior*), showing polygamous flowers (nat. ord. Oleaceae); *Claytonia alsinoides* (nat. ord. Oleaceae); *Alchemilla vulgaris*, the lady's mantle, small green flowers with no petals (nat. ord. Rosaceae); *Deutzia* (nat. ord. Saxifragaceae, sub. ord. Philadelphaeae); Dioecious flowers of *Aucuba japonica* (nat. ord. Connaceae); *Prunus lauro-cerasus*, the common laurel (nat. ord. Rosaceae). Mr. Austin exhibited some eggs of the Corvidae, and similar exhibits were shown on behalf of Mr. Wm. Bayne. Messrs. Bacot, E. M. Dadd, Bishop and C. B. Smith also exhibited. Records were given of the occurrence of a swallow on April 4th at West End Common, near Esher, and of a martin, nightingale and cuckoo on April 17th. Mr. Simes also recorded a wheatear redstart from Epping Forest on April 17th. Mr. Battley

had found the mistletoe parasitic on whitethorn and black poplar in Suffolk, and the cowslip-primrose hybrid plentiful in the same district. Mr. Austin read a paper on "The British Corvidae or Crow Family," in which he dealt exhaustively with each species and produced either coloured drawings or specimens to illustrate same. Messrs. Harvey, Battley, Frost, L. J. Tremayne, E. M. Dadd, Simes, Bacot, R. W. Robbins, Bear, Miss Simmons and Mr. C. Nicholson took part in the discussion which followed.—Thursday, May 13th, 1897. Mr. C. Nicholson, F.E.S., President, in the chair. Mr. P. J. Hanson was elected a member of the society. Mr. J. Burman Rosevear, M.C.S., read a paper entitled "My trip to Highcliffe and what I found in the Barton Beds." An interesting discussion followed.—*Laurence J. Tremayne, Hon. Secretary.*

**HULL SCIENTIFIC AND FIELD NATURALISTS' CLUB.**—At the usual meeting on Wednesday evening, June 9th, the President, Dr. J. Hollingworth, M.R.C.S., occupied the chair. Reports of excursions were given by various members. At Cottingham, Mr. Robinson had recently observed the bog pimperl (*Anagallis tenella*) for the first time, though the plant had been recorded for this district by Robert Teesdale about one hundred years ago. The same gentleman also reported having collected the bracteate sedge (*Carex divisa*) from Martlet Lane. This also confirms a record made by Teesdale. Several grass snakes were seen on the Marfleet Lane Excursion, one of which was captured. The usual disagreeable odour was emitted by the snake on being molested; but it is stated that this ceases when they become reconciled to captivity. Mr. G. H. Hill called attention to the fact that on a recent outing he had noticed that the beautiful clump of trees formerly surrounding "Blue Wells" near Barton had entirely disappeared, the trees having been cut down, leaving only a few stumps and a pond. It is considered a great pity that such a beautiful place as this was should have been so ruthlessly destroyed. Mr. J. W. Boulton stated that he had visited New Holland, and had found some specimens of the blood-vein moth (*Timandra amataria*) for the first time, although he had been looking for them for about twenty years. Mr. Porter had also made a good entomological find, viz., a "small yellow underwing" (*Helioica tenebrata*) near Springhead. This moth has not previously been found in this neighbourhood. The exhibits were of a varied and interesting character. Mr. Waterfall handed round a collection of plants and also a nest of small spiders, both of which had been collected on the Club's excursion to Goole Moor on Whit Monday. Mr. Boulton showed a beautiful collection of moths and butterflies just received from Natal. The Secretary exhibited a large ancient British flint implement, and the half of a Roman quern in splendid preservation, both of which had been found by him in Lincolnshire. Mr. Alex. Hicks was elected a member of the Club. A lecture on "The Extinct Animals of Holderness" was then delivered by the Secretary, Mr. T. Sheppard. The lecturer first gave an account of the geological history of Holderness, and pointed out that before this country was covered by the glaciers and ice sheets of the ice age, Holderness was not in existence, but a line of chalk cliffs stretched along from Flamborough, through Driffield, Beverley and Hessel, to the Humber Gap. The material left by the glacier on the final melting of the ice, formed the land which is now termed Holderness. For

convenience of classification, the deposits containing the remains of extinct animals were divided under three heads: pre-glacial, glacial and post-glacial. Under the first head were described the series of sands and gravels which are found banked up against the old cliff line, and have been exposed at Bridlington and Hessel by artificial excavations. These beds are covered by boulder-clay, an undoubted glacial deposit, and bones and teeth of elephant, rhinoceros, hippopotamus, bison and deer have been found in them, some of which have been gnawed, evidently by hyenas. Under the next head, the glacial series consist of sands, gravels and clays, which form the bulk of Holderness. The bones and horns of animals, usually very much waterworn, are almost invariably found in the gravels. The enormous collections of remains obtained when the Kelsey Hill and Brandesburton sections were worked several years ago, were referred to, and the lecturer also gave an account of his collection from the Burstwick gravel pit. The animals whose bones, etc., are found in the glacial beds, can be referred to the mammoth, deer, *Bos*, rhinoceros, horse, etc., the remains can be found in the museums at Leeds, York, Driffield, Hull and other places. The mammoth teeth so frequently found on the Holderness Coast were classed among the glacial series. The post-glacial beds were next referred to. These consist principally of layers of peat and old lake beds, which are found in hollows on the boulder-clay, and are therefore of later date. Excellent sections of these can be seen in the cliffs of our coast. In the peat, deer horns and bones are very common, though remains of ox and horse also occur. The old lake beds rarely contain mammalian remains, though deer-antlers have been found in them. An account of the peat beds and "submerged forests," with remarks as to their probable origin, concluded the paper, which was illustrated by specimens found in Holderness. A lengthy discussion followed.—*T. Sheppard, Hon. Sec., 78, Sherburn Street, Hull.*

**LEICESTER LITERARY AND PHILOSOPHICAL SOCIETY.**—The Biological Section, "D," of this Society made its first excursion this season on May 27th to an unfrequented part of Charnwood Forest, known as Lee Lane. This is a short by-way leading to nowhere in particular, only about half-a-mile in length, but bounded by woods on either side, and with broad, green margins tufted with bushes and overrun with brambles and briars. There are many damp and shady nooks, and the lane is rarely visited save by a few of the rustic inhabitants or an occasional gipsy camp. It is an interesting locality for mosses and Hepaticae. Here were collected patches of the rare British Hepatic *Kantia arganta*, producing abundance of pseudopodia, each crowned with a tiny ball of green gemmae. Also specimens of the very small *Fossombronina pusilla*, with *Pellia calycina*, *Chiloscyphus polyanthus* and *Conocephalus conticus*, and *Jungermannia ventricosa* and *J. sphaerocarpha*. Among the mosses found in this lane are *Anisothecium crispum*, *Climacium dendroides*, *Plagiothecium borevianum*, *Hypnum filicinum* and *Hylocomium splendens*. Several of these cryptogams are new records for the county or new localities. Among the phanerogams gathered were *Valeriana dioica*, *Lathyrus macrochitus* and its var. *tenatifolius*, *Asperula odorata*, *Chrysosplenium oppositifolium*, *Pedicularis sylvatica*, *Carex panicea*, etc. The lane ascends from a picturesque brook at the bottom, crossed by stepping-stones and a wooden foot-bridge, up a steep hillside, and from the

higher part a fine view is obtained of the Ulverscroft Valley. After two hours spent in this secluded spot the party walked on to Ulverscroft Priory, to view the ruined tower. This was once the only landmark in a wide range of forest-land, whose bells were echoed every Sabbath from a dozen rocky eminences around. It is still the landmark, though silenced and dismantled. In the ruined nave are hay and straw stacks, and the prior's residence is a roomy but antiquated farmhouse.—*F. T. Mott, Crescent House, Leicester.*

## NOTICES OF SOCIETIES.

## THE GEOLOGISTS' ASSOCIATION OF LONDON.

*Excursions and Conductors.*

- July 3.—Woking, F. Meeson.  
 " 10.—Whole day, Peterborough (Northamptonshire). A. N. Leeds, F.G.S., and A. S. Woodward, F.G.S.  
 " 17.—Bishop's Stortford (Herts.). Rev. Dr. Irving, F.G.S.  
 " 26 to 31.—Long Excursion, Edinburgh. Prof. James Geikie, LL.D., D.C.L., F.R.S.; J. G. Goodchild, F.G.S., and H. W. Monckton, F.G.S.  
 Sept. 4.—Whitchurch, Oving, Quainton. A. M. Davies, F.G.S. Baker Street, 9.37 a.m. for Waddesdon Manor.  
 " 18.—Holmesdale Valley. W. J. Lewis Abbott, F.G.S. Victoria (L. C. and D. R.), 1.30 p.m. for Otford.  
 For particulars of these excursions, apply to Horace W. Monckton, Esq., Secretary for Excursions, 10, King's Bench Walk, Temple, E.C.

LONDON GEOLOGICAL FIELD CLASS.—Conductor, Professor H. G. Seeley, F.R.S. (*Vide SCIENCE-GOSSIP*, Vol. iii., p. 328.)

- July 3.—Halling to Rochester. Cannon Street, 2.42 p.m.  
 " 10.—Hildenboro' to Sevenoaks. Cannon Street, 2.23 p.m.  
 " 17.—Upnor to Rochester. Cannon Street, 2.37 p.m.  
*Hon. Sec., R. H. Bentley, 43, Gloucester Road, South Hornsey, N.*

## THE SOUTH LONDON ENTOMOLOGICAL AND NATURAL HISTORY SOCIETY.

July 3.—Field Meeting at Reigate.

## NORTH LONDON NATURAL HISTORY SOCIETY.

The ordinary meetings of this society will in future be held on the *first and third* Thursdays in each month at the North-east London Institute, Dalston Lane, N., adjoining Dalston Junction Railway Station.

There will also be a special-family discussion, entitled "The Liparidæ," to be opened by A. Bacot on some date not yet fixed.—*Lawrence J. Tremayne, Hon. Secretary.*

## WOOLWICH POLYTECHNIC NATURAL HISTORY SOCIETY.

*Meetings and Lectures; Excursions and Conductors.*

- July 1.—Woolwich Polytechnic. "The Origin and Physical History of the Earth and Moon" W. Turner.  
 " 3.—Plumstead Church, 3 p.m. Manorway—mollusca and entomology. H. J. Webb.  
 " 10.—Plumstead Railway Station, 8 a.m. Chattenden Woods—entomology. S. Pine.  
 " 15.—Woolwich Polytechnic. "Queries and Replies on Astronomy," illustrated by diagrams, etc. T. W. Brown.  
 " 17.—Plumstead Railway Bridge, 3 p.m. Griffin Manorway—larvæ and mollusca. H. J. Sargent.  
 " 24.—Plumstead Railway Station, 2 p.m. Swanley district—mollusca. E. Dennis.  
 " 29.—Woolwich Polytechnic. "Setting Lepidoptera." A. S. Poore.  
 " 31.—Wickham Lane (north), 3 p.m. Lane to Kings Highway—reptiles, mollusca, etc. F. C. Farr.  
 Aug. 7.—Charlton Railway Station, 3 p.m. Charlton sand-pits—fossils and mollusca. G. Cornish.  
 " 12.—Woolwich Polytechnic. "Fish—their Structure and Habits." E. J. Cunningham.  
 " 14.—Plumstead Church, 3 p.m. Crossness—entomology. D. Millar. (For juvenile members.)  
 " 21.—Abbey Wood Railway Station, 3 p.m. Knee Hill and lanes—mollusca and pond life. W. Turner.  
 " 26.—Woolwich Polytechnic. "Setting and mounting Coleoptera." G. Cornish.  
 " 28.—Plumstead Church, 3 p.m. Ditch work in Manorway. H. J. Sargent.  
 Sept. 4.—Abbey Wood Railway Station, 3 p.m. Knee Hill and lanes—larvæ and mollusca. H. J. Webb.  
 " 9.—Woolwich Polytechnic. Exhibition by Microscopical Members. W. Scott.  
 " 11.—Plumstead Railway Station, 2 p.m. Greenhithe—mollusca, etc. E. J. Cunningham.

Sept. 18.—Plumstead Church, 3 p.m. Manorway—mollusca, ditch work, etc. J. E. Stacey. (For juvenile members.)

" 23.—Woolwich Polytechnic. "The Moon," illustrated by lantern views. T. W. Brown.

" 25.—Wickham Lane (north), 3 p.m. Bostal caves—*H. pulchella*, *Cl. rolphii* and *C. acicula*. T. W. Brown.

Meetings, alternate Thursdays, at Polytechnic, William Street, Woolwich, 7.30 p.m.—*H. J. Webb, Hon. Sec., Polytechnic; or 3, Gunning Street, Plumstead.*

## NOTTINGHAM NATURAL SCIENCE RAMBLING CLUB.

*Geological Section.*—Leader, Mr. J. Shipman, F.G.S.

- July 10.—Trowell, Stony Cloud and Sandiacre. Meet Midland Station, 2.30 p.m.  
 Aug. 28.—Annual Excursion, Lincoln. Fare (special train), 1s. 6d.  
 Sept. 11.—Hucknall Torkard and Long Hills. Meet Midland Station, 1.30 p.m.  
*Botanical Section.*—Leader, Mr. W. Stafford.  
 July 24.—Red Hill and Bestwood. Meet opposite Mechanics' Hall, 2.30 p.m.  
 Aug. 14.—Nottingham Arboretum. Meet Waverley Street Entrance, 2.30 p.m.  
 Sep. 18.—Radcliffe and environs. Meet G.N.R. Station, 1.45 p.m.  
 Oct. 16.—Annual Meeting, Rambling Club, Natural Science Laboratory, University College, Nottingham, 4 p.m. Tea, soiree and exhibition of collections made during season. *W. Bickerton, Hon. Sec., 187, Noel Street, Nottingham.*

## NOTICES TO CORRESPONDENTS.

TO CORRESPONDENTS AND EXCHANGERS.—*SCIENCE-GOSSIP* is published on the 25th of each month. All notes or other communications should reach us not later than the 18th of the month for insertion in the following number. No communications can be inserted or noticed without full name and address of writer. Notices of changes of address admitted free.

NOTICE.—Contributors are requested to strictly observe the following rules. All contributions must be *clearly* written on one side of the paper only. Words intended to be printed in *italics* should be marked under with a single line. Generic names must be given in full, excepting where used immediately before. Capitals may only be used for generic, and not specific names. Scientific names and names of places to be written in round hand.

THE Editor is not responsible for unused MSS., neither can he undertake to return them, unless accompanied with stamps for return postage.

SUBSCRIPTIONS.—Subscriptions to *SCIENCE-GOSSIP*, at the rate of 6s. 6d. for twelve months (including postage), should be remitted to the Proprietors, 86, St. Martin's Lane, London, W.C.

THE Editor will be pleased to answer questions and name specimens through the Correspondence column of the magazine. Specimens, in good condition, of not more than three species to be sent at one time, *carriage paid*. Duplicates only to be sent, which will not be returned. The specimens must have identifying numbers attached, together with locality, date and particulars of capture.

ALL editorial communications, books or instruments for review, specimens for identification, etc., to be addressed to JOHN T. CARRINGTON, 1, Northumberland Avenue, London, W.C.

## CORRESPONDENCE.

T. B. (York).—The insects boring holes in furniture are the larvæ of beetles of the genus *Anobium*, one of which is the "deathwatch." Some dealers in "antique" furniture get the same effect by shooting pellets into the furniture with a shot gun.

A. H. S. (Redbridge).—A worm of the genus *Gordius*, which is aquatic, though found also in damp places. It has no special connection with laurel leaves.

## EXCHANGES.

NOTICE.—Exchanges extending to thirty words (including name and address) admitted free, but additional words must be prepaid at the rate of threepence for every seven words or less.

WANTED, crustaceans, echinoderms, sponges, zoophytes, foreign shells and any other marine objects, fresh or dried, in exchange for other specimens, books, micro slides, etc.—H. W. Parritt, 8, Whitehall Park, N.

EGGS IN CLUTCHES.—Richardson skua, shag, gulls, terns and other sea birds to exchange for clutches of southern juncal birds.—Dr. Prond, Maryport.

## PRESERVATION OF RARE BRITISH ANIMALS.

BY JOHN T. CARRINGTON.

I HAVE been favoured with a small four-page reprint of half-a-dozen letters on the destruction of rare birds, which correspondence appeared a few weeks ago in the "Saturday Review." The writers were Mr. Joseph F. Collinson (of the Humanitarian League), Sir Charles Dilke, Bart., M.P., Mr. W. H. Hudson, C.M.Z.S., and Mr. Ernest Bell (a member of the Society for the Protection of Birds, who is also a member of the Humanitarian League).

The following passage occurs in the first of these letters, which is by Mr. Collinson :

"A 'specimen' of the hoopoe—a lovely creature—it is recorded, has recently fallen a victim to the 'murderous aim' of the collector. It was shot by the Rev. R. T. Gardner, at Garstang, Lancashire, on September 29th, 1896. When a clergyman shoots down rare birds one can scarcely wonder that other people who do not profess to be religious do the same. More recent examples are furnished in the case of the kingfisher. Several birds of this species have within the past few weeks been shot in different parts of the country. Two have been shot in the County of Durham, one in Surrey, one in Northumberland and one in Yorkshire."

To this letter Sir Charles Dilke replied, on April 24th last, in a short but sensible communication, to the effect that the kingfisher had in late years increased so greatly on the Thames that they were now as common in that district as they were thirty years ago, when Sir Charles first knew the river. The third letter in this correspondence is by Mr. Hudson, who, as a popular writer on British birds, doubtless knows what he is saying when he remarks that the kingfisher

"was almost annihilated by the terrible frost of January and February, 1895; and no wonder, for it had been reduced by constant persecution to an insignificant remnant; and for five or six weeks the watercourses were all frozen over throughout the length and breadth of the land, the cold being so severe as to kill the hardy furze down to its roots in most districts. Probably the only kingfishers that survived were those that migrated to the sea-coasts at the beginning of the intense cold. After the big frost I spent some months in tramping through Somerset and Devon, visiting a great many streams, always on the lookout for the kingfisher; but not one did I see, and the almost invariable answer to the enquiries I made was that the kingfisher had not been seen after the frost. There have since been two exceptionally favourable years—long bright summers and mild winters—and the birds have multiplied. During the last twelve months a good many kingfishers, in pairs and singly, have visited the ornamental waters in several of the London parks."

It is hardly necessary to refer to the remaining communications in this reprint, as they are written entirely from the humanitarian point of view, and

against those whom Mr. Bell describes as the "selfish collector." I need only remark that the letters are characterized by admirable evidence of good-natured sentiment, rather than practical knowledge. For instance, the latter gentleman indicates the danger of disappearance, among other birds, of nightingales and kites. Need I remark how improbable is the loss of the former, or how long since the latter ceased to be a British resident? The same gentleman refers to the kestrel as the "windover," evidently not knowing that its true popular name is "windhover," from its habit of hovering against the wind when in search of food.

In the following remarks I would have Messrs. Collinson, Bell and other humanitarians clearly understand that I have as much personal horror and disgust as themselves at the wanton and useless destruction of the rarer members of our fauna and flora. Still, we must guard against allowing sentiment to run into error, which it is very liable to do if every statement that appears in print passes unchallenged—especially in unscientific or irresponsible papers. My object is not to deprecate the preservation as long as possible of disappearing animals, but to point out that it is the inevitable result of the forces of nature and the civilization of mankind which are the causes of these disappearances, and not acts of the "selfish collector" nor "the cruel sportsman." With regard to the latter, in the case of birds, he is generally wrongly accused; the work of destruction is rarely by his hands. It is almost invariably the deed of the casual fowler. The ornithologist, in most instances nowadays, meets with his rarer specimens in the flesh, already dead and hanging in some poulterer's or other shop. He must indeed be a young collector who needs to go shooting kingfishers, when he can buy their ready-prepared skins at a cost hardly greater than that of the cartridges he expends upon their slaughter.

If it were possible to take a census of the wild-bird life of the British Islands and compare it with one taken half a century ago, I believe we should be surprised to find that the gross bird population is now greater, while in regard to native breeding species, hardly any have actually disappeared during the past half century. We should further find that some species more frequently nest in this country at the present time than when our first census was supposed to have been taken. For instance, one can mention the woodcock. Looking back on the names of some of the birds which have disappeared from our islands within the memory of man, we find that they have equally



left other regions of Western Europe where they were common at the period when they inhabited Britain. The one cause above all others for the disappearance of birds from any particular region is the difficulty of obtaining regular supplies of natural food. It is not necessary that the supply of this food should have actually ceased in any district, if the animals which depend upon it are unable to adapt themselves, while feeding, to artificial disturbances which may grow up around them. In fact, if we take the list of those birds that formerly habitually bred in this country, but no longer do so, we shall find that they are all more or less afflicted with timidity or shyness of man and his works, or that their food-supply is gone. Otherwise they are birds which have had to succumb to the competition of others more numerous or more assertive than their own species. As an instance of this, it appears to be only a question of time before house-sparrows will drive away one of our most lovely and interesting summer migrants—the house-martins. These pugnacious little finches have latterly contracted the habit of driving away the martins from their nests, which the sparrows themselves then occupy.

Taking the other point of view, namely, the consideration of those birds which now regularly breed in these islands, we find, first, they are species that have adapted themselves to man's civilization, or inhabit localities which have not been affected by railways, factories, cultivation of the land, or game preservation. With regard to the first type, or such as have contented themselves with the association with mankind, we need have no fear of their extermination. Their habits will in the future tend to a greater familiarity with human civilization and consequent increase in numbers. This point of view is confirmed by the fact that some of the formerly shyest of all shy birds, the wood-pigeons, have within quite recent times come to breed in our largest and most noisy cities throughout western Europe, herding with sparrows and starlings.

Other birds which are so frequently quoted by the humanitarian school of nature-lovers, would never, under existing circumstances, become permanent breeders in this country. Neither is it probable, under its wildest conditions, were they ever more than casual breeders. Among these are the often-quoted hoopoes and golden orioles. Most animals, indeed, we may say all species, live within certain well-defined geographical limits, and Great Britain cannot be within the limits of the above two kinds, nor of some other birds which so rarely fall into the hands of the "selfish collectors." They may be safely looked upon as storm-blown individuals, or unwilling migrants from some other cause, who would in course of time either return to their more congenial haunts or be killed by

cruel nature on the first approach of winter, or by other means. Were they birds which could readily adapt their habits to our country they would in time past have bred in such numbers that their offspring, under the influence of the hereditary passion for returning to the place of their birth to reproduce their species, would come as regularly every season as do the nightingales or the cuckoos.

In every division of nature and in every region of the earth there appear to be waves in the abundance and scarcity of certain species of the feral inhabitants. Returning to those of Britain, we may consider one of the most studied and best understood of the great orders—that of the Lepidoptera, or butterflies and moths. In my own time of active observation, extending to nearly forty years, we have known some species in many parts of the country which were generally common, or at least by no means rare, to have practically disappeared. As an example I may mention the "brown-tail moth" (*Porthesia (Liparis) chrysoorrhoea*), which twenty years since was a comparatively common species throughout the south of England, but is now rarely or hardly ever found. The same applies to that handsome butterfly, the "black-veined white" (*Apollonia crataegia*), which was abundant half a century ago throughout southern England and South Wales. Without mentioning others, these two instances are sufficient to prove that some other agency than that of the collector must have caused their disappearance; because, in the first place, there have never been in this country a sufficient number of persons who required specimens of these once common species to have exterminated them. Neither have some of the localities where they both abounded ever been visited by entomologist or collector.

I have every sympathy with those who have founded societies for the protection of our wild birds, and brought about Acts of Parliament for their preservation. As I have said earlier in these lines, I look with abhorrence on the useless, senseless and vulgar destruction of any kind of wild life. I admire equally the efforts which certain collectors of butterflies and moths have been making for the formation of an association to protect disappearing species in our fauna. Doubtless their efforts may prolong for a few years the stay of these species with us; but if their diminution is due to the forces of nature or to their inadaptability to accommodate themselves to human civilization, no amount of dilettante preservation will stop their ultimate extinction. While forming these societies and advocating the abstention from collecting, humanitarians must be careful not to allow sentimental feelings to interfere with the proper acquisition of representatives of our fauna for scientific purposes. I venture, however, to hold



the opinion that at no time has scientific collection caused the extinction of any species: neither has the senseless shooting of odd individuals of any kind of birds by casual fowlers exterminated their species. Perhaps two avoidable agencies may have contributed to hastening

the end of some, namely, the acquisition of birds for purposes of ladies' millinery, and the unmeaning rage among collectors for "British" specimens of species common on the other side of the English Channel, whence they are frequently blown over to our shores.

## VEGETABLE NATURE OF DIATOMS. (1)

By T. CHALKLEY PALMER.

THE essentially vegetable nature of diatoms is at the present time acknowledged by biologists almost or quite without exception. The phenomena of their increase and reproduction, if nothing else, are of a nature to call for their grouping in the same class with such undoubted plants as desmids and the Zygneceae. Yet every young student, seeing for the first time the glassy cells of diatoms moving about under his microscope in a manner that would seem to indicate a very animal-like volition, is liable to ask for some tangible proof of their plant nature, some more elementary argument than that drawn from relations which are to be apprehended in all their significance only after somewhat extended study.

However difficult, or even impossible, it may be to draw a definite line that shall separate the animal and vegetable kingdoms, it is probable that no one will object if the term "plant" is applied to an organism which, when exposed to sunlight, is found to absorb carbon-dioxide and to exhale oxygen. The method and apparatus described herein are designed to show that both these phenomena, which are so characteristic of plants in general, are characteristic of diatoms. Pelletan ("Les Diatomées") states that he has collected sufficient of the gas arising from diatoms to serve for the application of those usual chemical tests which prove it to be oxygen. But it is not easy to bring together the conditions that permit the collection, from diatoms alone, of such a volume of gas as is required for these tests. Considerable time, also, must be needed for the operation. This question of time is, in fact, important to the

success of the experiment: for in the absence of sunshine, or at least of bright daylight, it is found by experience that diatoms, and especially the motile forms that are expending energy in the way made evident by their motion, cease to exhale oxygen and begin to absorb it, or at least to give out carbon-dioxide. This phenomenon — the

evidence of an exothermic chemical reaction — the diatoms exhibit in common not only with animal organisms, but with all plants also. It is the well-known process of respiration, that which Gautier has called "the animal life of plants." The method I desire to describe is of great simplicity, and it yields conclusive results within an hour, provided the light be sufficiently strong; it does

not necessitate the collection of any appreciable volume of gas, and it demonstrates both phases of the endothermic reaction.

Haematoxylin, the chromogen of logwood, is peculiarly fitted to be an indicator in a case where it is desired to recognize the presence or absence of carbon-dioxide and the evolution of nascent oxygen, the solvent being ordinary water from spring or river containing its usual traces of various mineral matters. Under the influence of carbon-dioxide, the haematoxylin dissolved in such water loses its normal rosy or slightly bluish-red tint, and turns to a yellow with a tinge of brown. In the presence of nascent oxygen, on the other hand, the light-red hue deepens momentarily, and ends by becoming a very deep blood-red. The latter change is in a manner permanent, but the former is reversible, *i.e.* the rosy-red colour returns when the carbon-dioxide is removed. These well-known colour reactions are

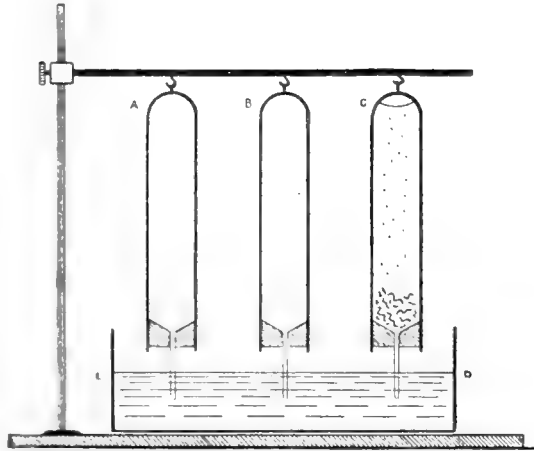

APPARATUS FOR TESTING VEGETABLE NATURE OF DIATOMS.

(1) Read before the Philadelphia Academy of Sciences.

of great delicacy, and are used in the following way:

A sufficient quantity of water is taken to fill all of the tubes shown in the figure, and the dish up to the mark D E. This is tinted with a sufficient quantity of a freshly-made solution of haematoxylin. The colour should be a very pale hue of red. The tube A is then filled, and the rubber stopper, with its penetrating quill-tube, is inserted, the last bubble of air is forced out by pressure, and the tube suspended as shown. The remainder of the solution is acidified with carbon-dioxide from the lungs, blown into it through a glass tube. The brownish-yellow tint having developed, tubes B and C are filled with the solution, and into C some clean, living diatoms are put. Both are then corked and hung as figured, the quill-tubes dipping below the surface of the liquid in the dish. These quill-tubes, which allow the pressure within the larger tubes, due to gas or to expansion from heat, to relieve itself into the dish, are drawn down to a very small opening in order to lessen diffusion of liquid up or down and to confine the diatoms. The apparatus is now exposed to bright light—if to direct sunlight so much the better, since the action is then more rapid. Gas arises from the diatoms in tube C, and simultaneously the colour of the liquid, which is at first like that in B, begins to change. Within fifteen minutes, under proper conditions, the colour has again become almost or quite as red as that in tube A. The carbon-dioxide has now in

large measure disappeared from the solution. The action continues, and the colour in tube C deepens rapidly, showing oxidation; and this action continues until the colour is quite blood-red or even, in case much lime is in the water, until bluish lakes are formed in clouds. The ceasing of the action may, conceivably, be determined by exhaustion of every trace of carbon-dioxide, but data on this head are wanting as yet. At all events the evolution of gas goes on long after the colour reaction of carbon-dioxide has disappeared.

The experiment may be varied in the following manner: All of the tubes are filled with the normal, non-acid, reddish solution of haematoxylin. Into A is put a living snail, into B live diatoms, and C is allowed to remain for comparison. The whole apparatus being exposed to sunshine, A pales rapidly under the influence of the carbon dioxide from the snail, while B as rapidly darkens and reddens compared with C, owing to the oxygen from the diatoms. This result, so significant, is obtainable in a very few minutes.

The diatoms selected for the above experiments were the long, broad filamentous forms of *Eunotia* (*E. major* of Rabenhorst), which are peculiarly applicable, because it is easy to procure them in sufficient abundance, and to free them, under a dissecting microscope, from any accompanying algae that might, by their presence, tend to cast doubt upon the conclusiveness of the results.

## THE COMING OF THE RAINS.

BY STANLEY S. FLOWER, F.Z.S.

(Communicated by SIR WILLIAM H. FLOWER, K.C.B., F.R.S.)

ALL those who have been through an Indian "hot weather" know the extraordinary difference "the coming of the rains" makes in the amount of visible animal life, which to those who have not experienced the change seems almost incredible. In Siam it is just the same—for months there is no rain. During January and February the climate is delightful—warm, dry days, with cool refreshing nights; in March and April comes the hot weather, the thermometer sometimes up to 102 degrees in the shade by day and only down to 95 degrees at midnight. The broad, alluvial plains between the rivers are a parched desert, the paddy fields being hard and sun-cracked, with no vestige of green. Birds are plentiful enough. All day long one hears the monotonous "pook, pook, pook" of the hot-weather bird (*Xantholaema haematocephala*) and the almost equally distracting cry of the köil (*Eudynamis honorata*), and one wonders what

Rudyard Kipling was thinking of when he wrote of "köil, little köil," and describes it as "the Indian nightingale," but one agrees when he sings:

"In my ears the knell of exile your ceaseless, bell-like  
speech is—  
Can you tell me aught of England, or of Spring in England  
now?"

The animal world seems dead were it not for the birds and the flying foxes (*Pteropus medius*) which every evening leave their roosting-tree by the village temple, where the Buddhist priests hold them sacred. These large bats fly off to such trees as they know to be in fruit. There are also a few monkeys and squirrels. True, many geckoes are to be seen about the houses at night, fleas swarm to an obnoxious extent in the dry dust of some of the paths, and "sand flies" abound, those irritating little insects just large enough to see but not to catch, which have a special *penchant* for biting

one's wrist and ankles; but for frogs, beetles, myriapods, worms, etc., one may search for hours in vain. Then come a few days of most oppressive heat, in spite of the sun being nearly hidden by great banks of dark, lowering clouds; everyone seems more or less miserable and is troubled with "prickly heat." The crows and mynah birds alone are cheerful by day and all through the stifling night the great house-lizards (*Gekko verticillatus*) are heard, now chuckling sardonically to themselves, or crying aloud clearly and deliberately, "to-kay, to-kay. One morning, more than ever, as Longfellow expresses it: "there was a feeling of suspense in nature, a mysterious sense of terror in the air"—till suddenly the weather breaks, first a furious wind, blowing showers of dust and leaves from every tree, tearing the broad banana leaves to ribbons, and carrying great pieces of attap thatching from the roofs, then lightning, thunder and a deluge of rain, which pours steadily for hours, till before sunset it ceases almost as suddenly as it began. Then the air is fresh, the distant view of trees and flat fields clear, the pleasant smell of rain and a moist earth again tempts one out, when one finds apparently a new fauna. A big, brown toad (*Bufo melanostictus*) jumps somewhat ponderously from under one's foot; agile little frogs (*Rana limnocharis* and *Microhyla ornata*) are hopping about; scores of small insect-eating bats are flying in all directions; cicadas are singing in the trees; and the grass, which suddenly has become green, seems alive with creeping things. As it grows dark, crickets are heard chirping everywhere, glowworms begin to show their light, and from near the river comes the croaking of frogs, the unceasing loud "waarr, waarr, waarr" of *Callula pulchra*, and at intervals the "opp, opp, opp" of the big bull-frog (*Rana tigrina*). On returning indoors, one realises at once that there is no need now to search for insects, they are coming in their thousands. If one sits down to read by the lamp, they crawl over the book, crush themselves between the pages, creep into one's hair, down one's neck and up one's sleeves. If we try to write it is the same, with the added inconvenience that they crowd into the ink-pot, some to die there and clog the pen, others to spring out again, scattering ink over the desk. At dinner it is the worst; one's food and drink is invaded by battalions and brigades of winged creatures, some very active, but most in various stages of dying, while all the time fresh hordes are flying in, buzzing, frizzling and flaring in the lights. Most numerous are the termites, which drop their four long wings about most untidily and then crawl wherever they are not wanted. Then there are winged ants—large and small—stoneflies, crickets, cockroaches, grasshoppers, beetles of many kinds, especially little black water-beetles, bugs of an infinite variety of

shape and colour, quantities of moths and now and then a big praying mantis.

Worst of all are the mosquitoes, as they are above flying at the light but follow one to the darkest corners of the house. This inroad is, however, thoroughly appreciated by the little house lizards (*Gehyra mutilata*, *Hemidactylus frenatus* and *H. platyurus*), which are busily engaged on the walls and ceilings till they can eat no more. In the evening my Indian watchman reminds me that the coming of the rains is a favourite time for Chinese and Siamese "loosewallahs" to break in and steal, so about midnight I take a lantern and have a look all round the house and outbuildings; and here again life is apparent everywhere, millepedes of several kinds are crawling aimlessly about the walls, finding little satisfaction in damp white-wash. Large spiders (*Heteropoda venatoria*?) are also abroad on the walls, but with more purpose, as the lantern shows many a one enjoying itself with a cockroach or other insect in its fatal grasp. Quaint scorpion-like creatures (*Thelyphonus*) are feeling their way cautiously about, using their long first pair of legs as antennae, but when disturbed dart away like lightning into some crevice, and once the light fell on a true scorpion (*Isometrus*) overcoming a cricket much larger than itself. To the naturalist the interest of all these varied living things around him far outbalances the discomforts and damp-heat of "the rains"; but for all that when bedtime comes he is not sorry, however keen he may be, to put mosquito curtains between him and them, and to fall asleep wondering whether the Arthropoda are, or are not, a natural group.

Bangkok; April, 1897.

THE VIRGINIA COLONY OF *HELIX NEMORALIS*.—Professor T. D. A. Cockerell contributes to our American contemporary, "Science," an interesting article upon the Lexington colony of our common-banded hedgerow snail. He has received from a correspondent a number of these shells gathered in 1896-97, and goes through the band formulae as well as colour variation. The value of these variations is to see the influence of environment not only in a new locality but also on a new continent. Thus to students of evolution the opportunity is exceptional. The colony has long been watched by Professors Cockerell, Morrison, and others, so that this contribution to our knowledge by Mr. Cockerell is in continuation of records by himself and others. He says: "The examination of the list brings out the apparent fact that new split-band variations are comparatively rare in the colony, though still more frequent than such forms are in Europe." He finds there were about 100 split-bands in 2,100 shells found by Professor Morrison, and about four per cent. found by his later correspondent.

## BLOOD AS A MICROSCOPE OBJECT.

BY DR. ALFRED C. STOKES.

I HAVE recently been examining, with great satisfaction, a mount of an object so common that every human being carries it about with him from even before the day of his birth to the moment of his death, and for some time after. He is unable conveniently to do otherwise. The object can therefore be obtained at any moment, and as its preparation calls for no preliminary treatment, this adds somewhat to its interest. The only objection is that age is a necessity for one structural feature, and for only one; the older the mount the better. Still for the purposes of this paper, a recently prepared slide will answer all the requirements.

The object is nothing more than a small drop of human blood mounted in its natural state and allowed to ripen, if so disrespectful an expression be allowable. The drop of blood must be left to dry under the cover and protected from the external air by the ring of cement. Prick the finger-tip, quickly touch with the drop a thin cover-glass; as quickly invert the blood over an exceedingly thin cell, or over a slip without a cell, so that capillary attraction shall spread out as thin a stratum of the liquid as may be, and, if possible, with but a single layer of red corpuscles. The cover is then to be rapidly cemented down, and the preparation left to itself for an hour or two, or for a shorter time. The entire mass of fibrin in the drop will coagulate, thus forming the object sought and which may be made so useful to the amateur microscopist, so instructive and attractive. It is best to use a drop so small or a cover so large that the capillary wave may become quiet and the material exhausted before the margin of the cell be reached.

If this preparation be allowed to remain in the darkness of the cabinet for a year, the red corpuscles will be gradually bleached and the reticulated structure of their protoplasm become superbly distinct and convincingly apparent, while the microscopist will have the satisfaction of knowing that no re-agent but time has touched the discs. With a good one-fifth inch objective, or with a higher power, these minute reticulations become defined in such a way that there can be no doubt as to their existence, but whether or not the network becomes visible by reason of the spontaneous bleaching, or of the more than probable changes that must take place as the dessication advances, I do not presume to say. But since the reticulations in the red corpuscles become more distinct, and apparently more numerous, as the preparation grows older, a little scepticism is not unnatural. However, the protoplasmic network can thus be

seen, whether the observer accepts or rejects the teaching that it is normal structure.

It is to the threads of coagulated fibrin that the microscopist is asked to look, with particular reference to the use of the object as a means for studying the adjustment of his objective. There is some reason to believe that, in this country at least, some amateur microscopists, some too that should know better, fail to study the effect of the collar-adjustment as it should be studied. Some of them either neglect it almost entirely, giving the collar a shove from time to time, and being content with that, or not giving it even so much attention, but setting it at any point which may be convenient and leaving it there. Another class is no less common, whose members use non-adjustable objectives with covers of improper thickness. What the British amateur does in this respect I have no means of knowing, but I have had some amusing experiences with the amateur in the United States of America. One man of whom I have heard, but in whose existence I refuse to believe, is said never to use covers less than one-fiftieth inch thick, because, as he can only afford cheap, non-adjustable objectives, he is unwilling that others more fortunate shall have the satisfaction of examining his preparations under better conditions than he can possess. I have searched my new dictionary in vain for a word to describe that man. Another man-like biped, whom I know existed at one time, and who claimed to be a microscopist, said, in reference to the adjustment-collar, "I don't know what that thing is, and anyway I don't know what it is loose for."

If the reader's blood is anything like mine, the fibrin in the mounted capillary film will coagulate in fine threads connecting every red corpuscle with every other; it will form clusters of filaments, isolated or aggregated into irregular skeins and flattened masses; it will produce minute figures like the delicate weaving of fairy spiders, or microscopic work from the looms of the elves. Disintegrated white corpuscles will be scattered about the slide in islands of colourless shreds and fragments, around which the fibrin will form its filamentous figures, and so unite the entire preparation into one reticulated entity.

Within the larger meshes, and sometimes under a different focus, can be seen a fibrinous network so minute that an eighth or tenth-inch objective is needed to display it distinctly, and even then the meshes are indescribably small, they are truly microscopic. It seems that not only does all the fibrin coagulate into a reticulation, but that the

liquor sanguinis itself, unable to evaporate and so escape from under the cover, has a tendency to produce a network and to dry into that form. The white corpuscle, and under certain conditions the common *Amoeba* and the *Pelomyxa villosa*, exhibit reticulated structure. If the true structure of protoplasm is not a reticulation, the certainty is that animal protoplasm is pretty generally free to assume that form.

The network just referred to is of such extreme minuteness and delicacy in the preparations which I have examined, and it is so nearly colourless, that some appreciable time must elapse, even with a homogeneous immersion one-tenth, before the eye can recognize it distinctly enough to separate the meshes, and look down into the interspaces.

When the coarser threads of fibrin are in focus with any objective from the one-fourth upward, the red corpuscles will be slightly beyond the focus, because the fibrin appears to have coagulated in actual contact with the cover-glass, while the corpuscles in the inverted drop have fallen to the lowermost surface, and have there become entangled within the net. If the objective, therefore, is very delicately sensitive to the collar adjustment, the lens will not be properly adjusted for the network on the cover and the red corpuscles on the lower surface of the capillary film, unless, as the reader, of course, knows, a homogeneous-immersion objective be used. The remark is correct for a first-class dry lens like, for instance, the superb one-fifth inch objectives by Spencer, having respectively 0.93 and 0.99 N.A.

All these nets, even the most delicate, may be used to advantage in studying the effect of the collar movement. When the adjustment is as good as possible, the filmy cobwebs will be visible with a beauty and a brilliancy that cannot be put into words. While the comparatively coarse threads and clusters may be observable with improper adjustment, with the correct position of the lenses those same threads will glitter like filaments and skeins and webs of polished silver. With the collar purposely thrown out of adjustment the objects may still be visible, but so dull and dead, with so ghostly and misty a vision of what they were at the objective's best, that the lesson must be of value to the eye of even the accomplished amateur. The comparatively huge masses of disintegrated white corpuscles share in the brilliant beauty, or in the lifeless dulness, as the collar is correctly or improperly placed. Under a wide-angled one-fifth, like those of N.A. fig. 93 and fig. 99 by Spencer, the correct adjustment produces a picture whose delicate lines and minute dots are drawn in vivid sparks and threads of living silver. With incorrect adjustment, or without the best, the minute network

is invisible, except perhaps as dull little bits of shapeless film scattered here and there among the red corpuscles. It is not possible with my dry objectives, which have been mentioned here, to separate these delicate filaments unless the collar has been placed exactly right, when they become as brilliantly refractive as the more robust threads, and as the crushed and broken colourless corpuscles, whose scattered fragments themselves sparkle and glitter.

The same slide may be used to give the microscopist somewhat of a surprise unless he is already familiar with the flatness, or the absence of flatness, in the field of his best objectives. With Spencer's one-fifth N.A. 0.99 the field is "unflat," if there is such a word, except as a little round spot in the middle, yet the objective, as a result of the optician's art, is as nearly perfect as it is possible to produce, and its definition and its resolving power can be described only by the words, magnificent, marvellous, and their colloquial synonyms. With his one-fifth N.A. 0.93 these qualities are much less brilliant, yet the field is flatter, or rather, it shows a greater surface of flatness at the same time; the effect of its smaller aperture.

527, Monmouth Street, Trenton,  
New Jersey, U.S.A.; July 2nd, 1897.

## BOTANICAL NOTES.

AMONG a number of commoner plants which have been sent for identification during the past month we may note: the Rev. W. W. Mason has sent us the alien *Sisymbrium pannonicum*, Jacq., from Crosby, Lancs. Mr. T. Brewster sends *Geranium lancastriense*, With., from Walney Island. Mr. White sends us *Potentilla hirta*, Linn., from a field near Montpellier House, Budleigh Salterton, Devon. The Rev. Vere F. Willson, of Fulbeck Rectory, Grantham, sends us *Orobancha elatior*, Sutton, from the Lincoln Heath. It is a native, but very rare in Lincolnshire. *Erysimum perfoliatum*, Crantz., is growing in a mangel-wurzel field at Cadney, Brigg. No doubt if allowed to seed it would be permanent, like *E. cheiranthoides*, Linn., which is found all over the fenland now, but is quite a late introduction in Lincolnshire. It was not recorded for the county till 1872. We hear from the Rev. R. W. Goodall, that he took *Trigonella purpurascens*, Lam., on Lincoln Heath, on July 2nd. This is a new record for the county.

LATE MIDSUMMER GROWTH. —Mr. A. H. Swinton, Clovernook, Southampton, writes: "The smaller oaks and beeches in the New Forest have now, at the commencement of July, put forth fresh green shoots as if a second spring had arrived."

## ARMATURE OF HELICOID LANDSHELLS,

WITH NEW SPECIES OF PLECTOPYLIS.

BY G. K. GUDE, F.Z.S.

(Continued from page 37.)

*PLECTOPYLIS magna* (!) (figs. 52a-f). With a miscellaneous collection of *Plectopylis*, from Burma, kindly sent to me by Miss

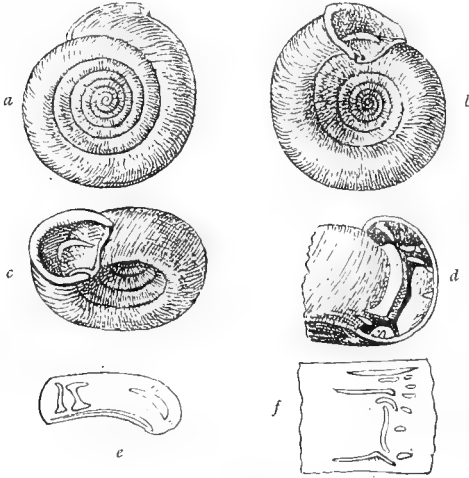
Fig. 52.—*Plectopylis magna*.

Lintner, Arragon Close, Twickenham, were two forms which appear to be undescribed, and,

(<sup>1</sup>) *Plectopylis magna*, n. sp. (figs. 52a-f).—Shell sinistral, solid, discoidal, widely and deeply umbilicated, horny brown, finely and regularly ribbed. Suture slightly impressed, spire depressed, apex scarcely raised. Whorls  $7\frac{1}{2}$ , a little rounded above, tumid below, increasing very slowly, the last widening a little towards the aperture, descending somewhat slowly in front, and a little constricted behind the peristome. Aperture elliptical, peristome white, thickened and reflexed, margins scarcely converging. Parietal callus with a raised flexuous ridge, separated from both margins of the peristome by a little notch. Umbilicus wide and deep. Parietal wall with a short, entering, flexuous, horizontal fold, which terminates at a distance of two millimetres from the parietal ridge at the aperture, and having at one-third of the circumference from the aperture two strong transverse plates; the posterior one the longest, vertical, and a little flexuous, giving off a short, obliquely raised ridge posteriorly above, and a short, strong, obliquely deflexed ridge posteriorly below; the anterior one oblique, the upper extremity converging towards the posterior plate, where it gives off posteriorly a short, strong ridge, and anteriorly a strong, longer ridge, which becomes attenuated; at the lower extremity it gives off two short, strong ridges, one posteriorly and one anteriorly; below these plates occurs a thin fold, close to the lower suture, revolving as far as the aperture, where it unites with the flexuous ridge. Palatal folds, 5; the three upper horizontal; the first straight and having an elongated denticle below it at about the middle; the second a little deflexed posteriorly; the third short, crescent-shaped; the fourth vertical, flexuous; the fifth horizontal, abruptly deflexed anteriorly above and posteriorly below. Posteriorly between the first and fifth folds occur six denticles, placed vertically in a row, the first in a line with the elongated denticle below the first fold, the second a little above and the third a little below the second fold, the fourth in a line with the upper extremity, the fifth near the middle, and the sixth a little below the lower extremity of the vertical fold.—Major diameter, 22.5-25 millimetres; minor diameter, 18.5-21 millimetres; axis, 8 millimetres.—Habitat, Burma.—Type in my collection.

although closely allied to each other and to *Plectopylis ponsonbyi* (ante vol. iii., page 178), they present sufficient differences to warrant their being regarded as distinct. Three of the specimens in question belong to the form which I now publish as a new species under the name of *Plectopylis magna*. A shell in the collection of Mr. E. R. Sykes, which had been labelled *P. achatina*, I also refer to this species. This new form differs from *P. ponsonbyi* in being much larger, more solid, and darker in colour, in having one whorl more, in the last whorl descending less abruptly, and in the whorls being more rounded. There are also differences in the armature, i.e. the two parietal vertical plates are convergent above, and the posterior one is considerably longer than the anterior one (see fig. 52e), while in *Plectopylis ponsonbyi* they are almost equal and parallel; the anterior plate gives off anteriorly below a short, stout ridge, not a distinct fold as in *P. ponsonbyi*, and the thin fold near the suture is distinctly continued to the ridge at the aperture, without becoming attenuated; the two upper palatal horizontal folds are much thinner, the third is short and crescent-shaped, and the vertical fold is not bilobed, while there are several more denticles posteriorly (see fig. 52f, which shows the inside of the outer wall). The specimen figured, received from Miss Lintner, as above mentioned, is in my collection, and measures 25 millimetres in diameter. A second specimen measures 22.5 millimetres in diameter. The third specimen is not quite mature, the ridge on the parietal callus at the aperture not being formed, but the armature is quite identical with that of the mature shells. Figs 52a, b, c and e are natural size, figs. 52d and f are magnified.

*Plectopylis lissochlamys* (<sup>2</sup>) (figs. 53a-f). The form

(<sup>2</sup>) *Plectopylis lissochlamys*, n. sp. (figs. 53a-f).—Shell sinistral, solid, discoidal, widely and deeply umbilicated, polished, corneous, finely and regularly ribbed, decussated with minute spiral sculpture above. Suture impressed, apex a little raised, spire depressed. Whorls 7, rounded, increasing slowly, the last twice as wide as the penultimate, widening towards the aperture, but not constricted behind the peristome. Aperture rounded, elliptical; peristome white, rather thin, reflexed; margins a little converging. Parietal callus with a raised flexuous ridge separated from both margins of the peristome by a little notch. Umbilicus wide and deep. Parietal wall with a short, entering, flexuous horizontal fold, which runs close up to the ridge at the aperture, and at one third of the circumference from the mouth there are two rather thin transverse parallel plates, descending obliquely backwards, the posterior one longest and with a short ridge posteriorly both at the upper and the lower extremities; the anterior one with a longer ridge anteriorly at the upper extremity, and two short but stouter ridges at the lower extremity, one anteriorly and one posteriorly below these plates occurs a thin horizontal fold close to the lower suture, becoming attenuated but distinctly perceptible at the aperture, where it unites with the flexuous ridge.

received with *P. magna*, as above mentioned, I propose to distinguish as *Plectofylis lissochlamys*. Two specimens were sent to me by Miss Linter. Dr. von Möllendorff, the German Consul in Manila, Luzon, however, has obligingly sent me for inspection several specimens of *Plectofylis*, amongst which are two (labelled *Plectofylis refuga*) which I refer to this new species. *Plectofylis lissochlamys* differs from *P. magna* in being much smaller and shining, as well as paler in colour; the shell in shape and texture resembling *Plectofylis fulvinaris*, which, however, is a dextral shell (*ante* vol. iii., page 180, fig. 25). It is more solid and darker in colour than *P. fonsonbyi* and it is more coarsely ribbed; the two last whorls increase more suddenly, and the last is not constricted behind the peristome as is the case in *P. fonsonbyi*. The two parietal plates (see fig. 53e) are much thinner, and the anterior ridges of the anterior plate much shorter and slighter than those of *P. fonsonbyi*; they are parallel instead of convergent as in *P. magna*. A comparison of the figures will indicate differences in the palatal armature. The specimen figured is in my collection and measures 19 millimetres in diameter. Figs. 53a-c are natural size, while figs. 53d-f are magnified. Fig. 53d shows the parietal and palatal armature from the

sideration, and *P. trochospira* and *P. polyptychia*, both of which latter will be dealt with in a future paper. As *Plectofylis quadrasi* has never been figured, I

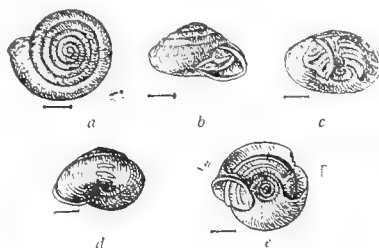

Fig. 54.—*Plectofylis quadrasi*.

have much pleasure in now illustrating it. The shell is dextral, openly umbilicated, depressed conical, thin, dark horny brown, regularly ribbed above and finely striated below. The suture is impressed, and the spire a little elevated. It is composed of six rounded whorls, which increase very slowly and regularly, the last not descending in front, keeled at the periphery, and obtusely angled around the umbilicus, which is deep and moderately wide. The aperture is diagonal, irregularly heart-shaped, and the peristome is brown, a little thickened and well reflexed, the margins being a little convergent and united by a slightly elevated, sinuous ridge. The parietal armature consists of two parallel horizontal folds, which extend over nearly half a whorl, the upper one being the strongest and united to the ridge at the aperture, while the lower one is thinner and does not reach quite so far; at their posterior terminations these two folds are united by a slight vertical ridge, which projects a little beyond the upper fold (see fig. 54e, which shows the shell with the outer wall removed as far as the peristome). The palatal armature is composed of three short, parallel horizontal folds at one-third of the circumference from the mouth (see fig. 54e, which shows the shell with part of the outer wall removed, so as to expose the anterior view of the palatal folds, and fig. 54d, which shows the entire shell with the palatal folds as they appear through the shell-wall). The two specimens figured are from Palanan, North Luzon, and are in my collection; they measure, major diameter, 3.5 millimetres; minor diameter, 3 millimetres; axis, 1.75 millimetres. All the figures are enlarged.

(To be continued.)

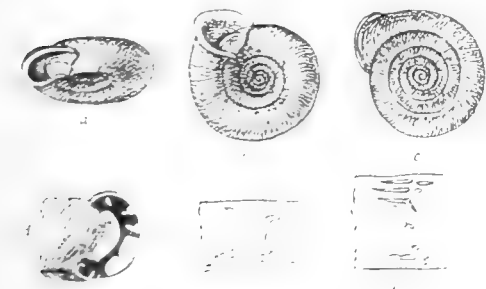

Fig. 53.—*Plectofylis lissochlamys*.

posterior side; fig. 53c a part of the parietal wall with its plates; and fig. 53f the inside of the outer wall with its folds and denticles.

*Plectofylis quadrasi* (figs. 54a-e) was described by Dr. O. F. von Möllendorff, in the "Nachrichtsblatt der Deutschen Malakozoologischen Gesellschaft," xxv., 1893, p. 172. It was collected near the village of Siamiam, in the Province of Cagayan, Luzon, Philippine Islands. Only three species of *Plectofylis* have hitherto been recorded from the Philippine Islands, viz., the species now under con-

Palatal folds, 5, the three upper horizontal, thin, the first and second with a denticle posteriorly, the third deflexed posteriorly, the fourth vertical, the upper part deflexed anteriorly, the lower part deflexed posteriorly, with two denticles posteriorly, one about the middle and one near the lower extremity, the fifth short, horizontal, indented at the middle, with a slight curved denticle posteriorly. Major diameter, 17-20 millimetres, minor diameter, 16-17 millimetres, axis, 6-7 millimetres. Habitat, Burma.—Type in my collection.

KANGAROOS IN BRITAIN. — Will any variety of this group of animals bear the varying changes of the English climate with its range of heat and cold; I refer to the latter especially, without the application of artificial heat. Could a pair be procured at a moderate price? Henry J. Barber *Brighouse, York*.

## NATURAL HISTORY IN NEW FOREST.

ON June 4th, 1897, a number of members of the North London Natural History Society started for their annual Whitsuntide excursion to the New Forest. The majority of the party left Waterloo by the 6 p.m. train and reached Lyndhurst about 10, the journey being an unusually long one. Mr. C. B. Smith, who was in command of the excursion, and some others, joined on the following day, several having ridden down from London on their bicycles. Owing to the increased numbers of the party, it unfortunately had to split up, some, including the ladies under Mrs. Nicholson, staying at Lynwood, and others at Brockenhurst.

Saturday broke dull, with signs of rain, but, with their usual heedlessness of the weather, several of the party were early astir. Larva-beating in Beechen Lane was tried with poor success. Scarcely anything worth taking seemed to be about, though the commoner sorts were plentiful enough. For once in a way *Hybernia defoliaria* was not the commonest larva, that honour being about evenly divided between *H. marginaria* and *H. aurantiaria*. *H. defoliaria* had probably mostly gone to pupae. Of imagines there were found a few *Pechypogon barbalis*, *Iodis lacteocerya*, *Acidalia rumutata* and one *A. straminata*. The fences only yielded a fine specimen of *Hadena genistae* to Mr. Woodward, who, however, met with some success in the ornithological department, discovering, amongst others, a nest of the garden-warbler. Disgusted with larvae, the party went home to breakfast.

Meanwhile the weather turned out fine by 10 o'clock, the day being hot. The first part of the excursion programme consisted of a visit to the Knightwood oak. Accordingly, soon after breakfast, most of those present started for the celebrated giant-oak, though, as will be seen later on, nearly all failed to get there. Mr. L. J. Tremayne opened his entomological account with a superb little specimen of *Acidalia trigeminata*, and Mr. C. Nicholson found a field where *Euchloe cardamines* was on the wing. As the party proceeded it became evident that *Pararge egeria*, in all conditions, was also flying, *Gonepteryx rhamni* was ovipositing, *Argynnis euphrosyne*, apparently not fully out, was seldom to be seen more than one at a time, and several of the commoner Geometrae were to be had by beating. An insect which appeared to be in greater abundance than usual was *Formica rufa*. The route taken being *via* Bank, the party soon entered Gritman Wood, where larva-beating was once more tried. Presently, larvae of *Taenioctampa miniosa* and full-fed *Thecla quercus*, together with a few *Psilura monacha*, began to come down. Mr. Jennings also met with some

success in the Diptera, Hymenoptera and Coleoptera. Before reaching the Lymington River, a halt was called, as it was found impossible for the ladies to continue in the heat of the sun, whereupon they, with Mr. Nicholson, Senr., decided to abandon the walk. Messrs. Bacot, Bishop and Jennings, finding collecting improving, decided to remain more or less where they were, and Messrs. C. Nicholson and L. J. Tremayne were left to push on to the Knightwood oak, alone. They first turned into Rhinefield, where the President took a fine specimen of *Macroglossa bombylififormis*, but no more were seen, though another collector on the ground stated that he had been there the whole morning, and only taken three, of which one was worn. The President and Secretary subsequently succeeded in reaching the Knightwood oak. The girth was measured and found to be six yards two feet three inches. But the tree is tall in proportion to its thickness, and has rather a slender appearance than otherwise from a distance. It was, however, a matter of regret to find it thickly strewn round with dirty pieces of paper and other rubbish, evidently the relics of picnics, which made it very unsightly. The wanderers subsequently proceeded through Mark Ash and Boldrewood, and home by the Ringwood Road, *via* Emery Down. Messrs. Bacot and Bishop had augmented their larvae by *Asphalia videns* and *Nyssia hispidaria*. Messrs. Harvey and Woodward, who had been at Rhinefield, succeeded in capturing both the bee-hawk-moths (*M. bombylififormis* and *M. fuciformis*), and had turned up *Tanagra atrata* and a larva of *Bombyx quercus*, whilst the oological records had been increased by nests of dove, chaffinch and linnet. Messrs. Jennings, Bacot and Bishop had been attacked on the Christchurch Road by a species of *Tabanus* which resembled *T. autumnalis*, but which Mr. Jennings thought must be a different species, as the specimens were worn. After a hearty tea, some of the members started for evening work. To begin with, Mr. C. Nicholson knocked down a flying specimen of *Asemum striatum* in the garden, and this was one of the very best captures made during the visit. Up to the year 1893, this beetle has never been found in the south of England, being essentially a northern species, though occurring in a certain locality in Cumberland. At Whitsuntide, 1893, a single specimen was taken in the New Forest by Mr. Bertram Rye, who again met with it in 1895, when he captured two specimens at Bookham, Surrey. It is, like all the Longicorns, a wood-borer, and is attached to pine and fir. How it had been introduced from Scotland to the south of



England, Mr. Jennings could not imagine. After this interesting capture, Messrs. C. Nicholson, L. J. Tremayne, Bacot, Bishop and W. H. Smith, with Miss Nicholson and Miss Bacot, made for Hurst Wood. Scarcely anything flew at dusk, a few *Melanippe montanata* being about the only captures, though New Park was tried as being better ground. Sugar also was an utter failure, not attracting a single lepidopteron. Larva beating produced a few *Asphalia ridens*, *Thecla quercus*, and *Psilura monacha*. Messrs. Harvey and Woodward, however, were successful in taking *Scodionia belgiaria* on Whitemoor.

A trip to Beaulieu had been arranged for Sunday, but as the day was again intensely hot, the members decided not to go so far. Several stayed at home, but a collecting party left Lynwood, after breakfast, for Beechen Lane, Denny and Matley Bogs, and Stubby Copse. Beating in Beechen Lane, Mr. Bishop brought out a specimen of *Fpione adenaria* and Mr. Bacot one of *Gnophria rubricollis*. *Bombyx rubi* was found commonly on the heath near Denny Bog, as well as a few *Sacurnia carfani*. Mr. Woodward also took *Lithoa mesomella* and *Gnophria rubricollis*. The larvae beaten were *Taeniocampa miniosa*, a few *Asphalia ridens*, *Thecla quercus*, *Amphidasys strataria* and *Psilura monacha*. The party remained out the best part of the day and returned by the Beaulieu Road, picking up some more *Scodionia belgiaria* on Whitemoor. The Vice-President took a fine specimen of *Euphitecia togata* from a fence. Meanwhile Messrs. Jennings and W. H. Smith had spent the day at Rhinefield and taken six specimens of *Macroglossa bombyliiformis*. They also found several species of large Syrphidae in numbers at the rhododendron blossoms. Amongst them were *Sericomyia borealis*, *Criorrhina oxycanthae*, *Volucella comylans* var. *flumata* and *Myiatropa florea*. *S. borealis* much resembles a wasp, both in its markings and in its manner of flight, and when caught produces a loud humming noise by the vibration of the halteres, which resembles, in miniature, the crying of a child. A single specimen of *Conops vesicularis* was seen, but, unfortunately, escaped.

On the way home, Mr. W. H. Smith took one *Metrocampa margaritaria*, one *Geometer vernaria*, and one larva of *Catocala sponsa*, beaten from an oak close to Clay Hill. The larvae of *Diloba coeruleocephala* and *Nola cucullatella* were abundant on the banks of the Lymington River, and in Hurst Wood Mr. Jennings saw a female *Diocrea velandica*, one of the predatory dipterous flies with its prey in its jaws. Beechen Lane and Whitemoor were the scenes of the evening work. Sugar was as useless as on the previous night, and netting moths at dusk only slightly improved.

On the Monday, Mr. C. B. Smith, Mr. Nicholson, sen., and all the ladies, except Miss Saunders,

elect to drive to Rufus Stone. Miss Saunders spent the day collecting ferns in Pond Head, and Jones' Enclosures and Beechen Lane. The rest of the party started for Matley Bog, *via* Whitemoor. For Lepidoptera this was the best day of the trip. The alder swamps in Matley Bog yielded *Hydrelia uncula*, *Eupistria heperata*, *Hypsifetes impluviata* and one *Erastria fasciana*, while *Aspilates strigillaria* occurred not uncommonly on the heaths, and *Drefana fulcataria* was found among the birch. Mr. Jennings met with the only good weevil taken during the trip, a specimen of *Erirrhinus bimaculatus*, and also the best species of Diptera taken, *viz.*, a male of *Spibomyia speciosa*, boxed from the side of the brook running through Matley Bog. This gentleman also obtained a female of *Merodon equestris* (Syrphidae), which Mr. Nicholson had taken at flowers in the Lynwood Garden. This is an introduced species, having been brought to England in bulbs, in which the larvae feed. It is now well-established in this country. The party returned home early, and after a hearty tea caught the 7 o'clock train back to London.

Mr. Jennings reports the following species, other than Lepidoptera, taken during the trip, in addition to those already mentioned:—*Geodephaga* (ground beetles); *Calosoma inquisitor*, two beaten from oaks, and one each from hazel, beech and Hawthorn; *Abax striola* and *Harpalus rubripes*, one each under log on a heath; one *Dromius 4-maculatus*, and one species each of the genera *Pterostichus*, *Notiophilus*, *Harpalus* and *Calathus* (not yet named); *Brachelytra* (rove-beetles); *Crochophilus maxillosus*, one under a dead rabbit on Whitemoor; *Necrophaga* (burying beetles); *Silpha 4-punctata*, beaten commonly from oaks; *S. rugosa*, one; *S. sinuata*, several obtained from the before-mentioned dead rabbit; *Saprinus*, two unnamed species from the same source; *Lanellicomia*, *Geotrupes vernalis*, one on Whitemoor; *Trox sabalosus*, one under an old rag at a spot where there had evidently been a gipsy encampment; *Melolontha vulgaris*, several beaten from oaks; *Phyllopertha horticola*, four in various situations; *Leucanus cervus*, several; *Elateidae* (click beetles); *Campylus linearis*, one out of hawthorn; *Colymbetes nolosericus*, common on oaks; *Malacodermata*; *Dolichosoma nobile*, one from aspen; *Longicornia*; *Anoplodera sexguttata*, one on a wall; *Rhagium bifasciatum*, three; *R. inquisitor*, one at sugar in Jones' enclosure; *Clytus altitus*, two on dead wood; *Toxotus meridianus*, one netted, flying near the Lymington River at Rhinefields; *Strangalia nigra*, three from Matley Bog; *Phytophaga*, *Clythra quadripunctata*, one taken by Mr. Bacot at Denny; *Cryptocephalus lineola*, one from heather on Whitemoor; *Adimonia capreae*, several; *Phytodecta uminalis*, several; *Heteromerus Lagria hirta*, one out of an oak in Hurst Wood; *Rhynchophora* (weevils); *Attelabus curculionoides*, two out of oaks;

*Rhynchites pubescens*, several out of oaks; *Otiorrhynchus picipes*, several from hawthorn; *Strophosomus coryli*, common on anything but hazel; *Hyllobius abictis*, one; *Evirrhinus tertrix*, two from aspen; *E. maculatus*, several from aspen; *Balaninus glandium*, one beaten from oak; Diptera—*Bombylius major*, one in a most dilapidated condition, having half of both wings gone and very ragged pubescence; Hemiptera—

heteroptera—*Acanthosoma*, three specimens of a species beaten from hawthorn. A yellow species was common on oaks, and a fine green capoid was beaten from hawthorn at Rhinefields; Hymenoptera; Tenthredinidae—*Tenthredo maculata*, one specimen, taken by Mr. Harvey near Brockenhurst.

Lawrence J. Tremayne, Hon. Secretary.

## THE PHYSICAL STATE OF MARS.

BY FELIX OSWALD, B.A. (LOND.)

ONE of the most interesting points of connection between geology and astronomy consists in the comparison of the present physical state of our globe with that of the nearest members of the solar system. Unfortunately such a comparison is necessarily restricted, since the majority of the planets are shrouded in dense atmospheres, apart from the consideration of the vast distances which lie between us and them. Mars and our moon are the only two of our neighbours which offer their entire surface to the scrutiny of our telescopes, for it is but seldom that any part of Venus is uncovered by clouds.

The terrestrial vibrations due to the neighbourhood of large towns, as well as the density and frequent obscurity of our own atmosphere, have also proved to be serious drawbacks to the observation of minute details. It has, however, been latterly recognized that pure, steady air and a lofty, isolated situation offer greater advantages to an observer than the largest telescope placed in such a locality as the Greenwich Observatory.

The remarkable work done within recent years under the most favourable atmospheric conditions, by keen observers such as Professor Barnard at the Lick Observatory, Professor Pickering at Arequipa, and more especially Mr. Lowell in Arizona,<sup>(1)</sup> has added enormously to our knowledge of Mars and our moon. In both cases we have to deal with a later stage of physical development than that existing on our globe; but while the moon is evidently a dead world, Mars is an example of vital but mature old age. In the case of the moon, the distinctness with which the physical features can be discerned is due not merely to its close proximity, but above all to the non-existence of an atmosphere; in the case of Mars (some forty million miles distant even when nearest to us) it is due to the extreme tenuity of the gaseous envelope, which is only one-seventh as dense as ours, and to the consequent absence of clouds, except to a very slight extent at sunrise and sunset. The manner in which the presence of clouds depends on the density of the atmosphere

may be readily noticed on our world, where the lowest clouds are the largest and thickest, while the highest consist of the delicate, fleecy cirrus or "mackerel-sky," composed of ice-crystals, and existing at a height of about five miles. Now our atmosphere even at this altitude is denser than that at the surface of Mars, so that this circumstance alone affords a ready explanation of its cloudlessness.

Although the Martian atmosphere is so much thinner and rarer than ours, owing chiefly to gravity being less, yet it is probably similar in composition, as shown by Dr. Stoney's ingenious deductions from the molecular theory of gases. It is in accordance with this theory that any gas consists of millions and millions of similar molecules moving unceasingly in all directions with a high velocity varying only with the nature of the gas; thus the molecules of hydrogen, the lightest gas, have been shown to possess a maximum velocity of over seven miles a second at 0° C. Now if a projectile be shot vertically upward from the earth it would travel away into space with a constant velocity, never to return unless the attractive force of the earth is sufficient to drag it back again. This attractive force, called gravity, depends on the mass of the earth, and therefore the earth can only control projectiles endowed with a definite limiting speed termed the "critical velocity," which in the case of the earth is about 6.9 miles a second. Hence if we know the mass of a planet we can at once determine the various gases which are likely to be present in its atmosphere. In this way Mr. Lowell shows that we can satisfactorily account for the absence of free hydrogen from our atmosphere, since the maximum molecular velocity of hydrogen is greater than the critical velocity of projectiles with regard to the earth. On the other hand, since the molecules of water-vapour, nitrogen, oxygen, and carbon-dioxide possess a lower velocity (2½, 2, 1.8 and 1.6 miles a second respectively), they have never been able to escape into space. The moon has no atmosphere at all, because it can only restrain molecules with a velocity of not more than 1½ miles a second, which is less than the

(1) "Mars." By Percival Lowell. Longmans, 1896.

molecular velocity of any of these gases. But the critical velocity of molecules with regard to Mars is as much as 3.1 miles a second, and consequently this planet would be able to retain exactly the same gases that exist in our own atmosphere.

The climate of Mars seems to be astonishingly mild and equable: while winds, owing to the flimsiness of the atmosphere, must be of the weakest description. Nevertheless, it seems evident that there must be a gentle upper drift of moisture-laden air proceeding from the equator towards the poles, and depositing its vapour in the form, not of rain or snow, but of successive hoar-frosts, thus giving rise to the conspicuous polar ice-caps more than 2,000 miles in diameter.

Owing to the axial tilt of Mars to its orbit being very little more than ours, a similar succession of seasons take place, but its far greater eccentricity of orbit causes the difference between the seasons to amount to seventy-four days, instead of merely eight, as with us. At the present period Mars is in an exactly similar condition to the earth with regard to the position of the "apse-line," *i.e.* the line joining the points of nearest approach to, and farthest recession from, the sun; the result being that winter in the southern hemisphere is longer than summer, and conversely in the northern hemisphere. But the Martian year (687 days) is nearly twice as long as ours, so that the heat of even a short summer is sufficient to completely melt the polar ice-cap, as it did in 1895.

Since Mars is much smaller than the earth, it is clear that it must have cooled down more rapidly, and hence we may naturally expect to find that its surface, which is little more than one-fourth that of ours, has reached a more mature physical condition. Now the absence of shadows at sunrise or sunset shows that the land on Mars must be singularly low, with no trace of mountain ranges. Volcanoes seem to be equally wanting; if they existed they could not fail to be conspicuous; for since gravity at the surface is only 37% that of the earth, and since atmospheric resistance is likewise so much less, it is clear that volcanic bombs and dust would be hurled to far greater heights, would spread out further, and would form craters of colossal magnitude, probably comparable with those on the moon. But there are no shadows thrown, either by mountain ranges or volcanic peaks and craters; no indication of volcanic eruption has ever been seen, nor has any cloud of volcanic ash appeared, such as with us sometimes covers darkness over hundreds of square miles. The absence of mountains would seem to point to the conclusion that Mars has probably attained the limit of contraction of a cooling globe. For it is now generally admitted that mountain ranges are primarily due to the attempt of the crust

to accommodate itself to a still contracting nucleus. Tangential stresses are thus set up in the crust, causing the softer and more yielding areas to be ridged up and crumpled between harder resisting blocks. Now, if mountains were no longer formed there would cease to be any compensation for atmospheric denudation, which would accordingly proceed unchecked until the seas became largely silted up, and the land planed down to a nearly flat surface, rising by gentle gradients to a height only slightly above the sea-level. This condition must have been reached long ago by Mars, which exhibits phenomenal flatness.

The surface-colouration is of two tints: reddish-ochre and bluish-green. The former colour preponderates and appears to represent extensive sandy deserts traversed by the wonderful so-called "canals," which have attracted so much attention since their discovery some time ago by Schiaparelli. But before discussing the nature of the "canals," it is necessary to say that the blue-green areas, hitherto termed "seas" and "gulfs," have been clearly demonstrated by Mr. Lowell to contain no water, for the following reasons: no glint of sunshine is ever reflected from their surface; the light proceeding from them is not polarized as it would be from a sheet of water; their colour changes with the seasons; and lastly, they are intersected by dark lines in direct continuation with the "canals" which form so geometrical a network over the wide-spread deserts. In all probability the blue-green areas are the lower regions of a monotonously level world, and occupy the sites of what were oceans in the time when Mars could still boast of mountains and rivers. The sea-beds would naturally remain the most humid parts, even when they became exposed to the air: for the amount of interstitial water locked up in ordinary sediments amounts on an average to ten per cent. It is likely that these regions now represent areas clothed with vegetation. The "canals" are apparently of the same blue-green colour; they proceed from dark, triangular spots at the edge of the "seas," and often radiate in fan-like groups of four or more. They run in absolutely straight lines, sometimes for more than 3,000 miles (*e.g.* the Eumenides-Orcus "canal"), although they naturally appear to us as large curves, since they form arcs of great-circles of the planet. The "canals" range from fifteen to thirty miles in breadth and cut up the desert-land into large triangles. Wherever the "canals" intersect, a dark circular spot is visible. Mr. Lowell points out that the very fact of three or more meeting at one place is, by the laws of probability, a strong presumption in favour of their having been constructed by intelligent beings, and against the theory that they might be natural geological phenomena, such as "rift valleys," or the "rifts" of the moon. They annually undergo great changes

in visibility and tint as the seasons pass, sometimes becoming so narrow as to exceed the limit for distinct vision, at other times widening and even becoming double. Such yearly and seasonal transformations render it nearly certain that they are not water-channels (at least not in their entire breadth), but broad zones of vegetation, probably stimulated to active growth and luxuriance by means of a net-work of irrigation-canals too narrow to be individually discernible by our telescopes at a distance of forty million miles or upwards.

The so-called "lakes" are the circular spots (likewise blue-green in colour) which always occur at the junctions of the "canals"; they have also been misnamed, for Mr. Lowell has conclusively shown that they have a much better claim to be termed "oases." The greater number are similar in size, about 120 to 150 miles in diameter, with one very notable exception, the "Eye of Mars" or "Lake of the sun." This is a conspicuous elliptical area in the midst of a large desert, but connected by short "canals" (about 250 miles long) with the greenish region of permanent vegetation to the south, west and east.

Now Mars must, on the whole, be remarkably deficient in water; indeed, the whole supply seems to be derived from the annual melting of the polar ice-caps. As the summer proceeds, the ice-cap is seen to diminish in size and to be surrounded by a dark blue zone, which must clearly be water, not merely because of its colour, but from the fact that it polarizes light. Moreover, it must be fresh water, since it is derived from the melting of the ice which is formed by the successive precipitation of heavy rime during winter. This belt of water, some 300 miles broad, closely follows on the shrinking ice-cap, and finally gives way in its turn to yellow land. The natural inference is that the water must be drawn off from the pole towards the equator. This inference is borne out by the fact that soon after the ice-cap begins to melt the "canals" and oases come annually into visibility, each in the place occupied in previous summers, and grow more and more conspicuous. The distinctness of detail sweeps gradually over the surface of Mars from pole to equator, during the summer; the oases appear very shortly after the "canals" become visible, and increase in depth of tint. This curious wave of growth is probably to be explained by the fact that the fresh water derived from the annual melting of the ice-cap is carried by irrigation-canals into the equatorial deserts; that, owing to the water thus conveyed, vegetation is able to grow along each canal so as to form a zone fifteen to thirty miles broad, and that each oasis, being at the intersection of two or more "canals," is more richly supplied with water and hence can extend

further into the desert. It should be noticed, moreover, that the size of an oasis seems to be in direct proportion to the number of "canals" passing through it.

The longer the surface-features of Mars are studied, the more irresistible is the conclusion that these "canals" and oases are the outcome of an intelligent design, contrived for the purpose of cultivation in order to meet the difficulties caused by an increasing dearth of water. We can well imagine that the date when the polar ice-cap first begins to melt is an anniversary of far more anxious importance in Mars than the rise of the Nile in Egypt or the arrival of the monsoon in India. We have of course, no reason to suppose that the inhabitants of Mars resemble us, or anything else on this world of ours. In the first place, they must be creatures capable of existing in a highly rarefied atmosphere, and the possibilities of life under physical conditions so different to ours are almost beyond the reach of imagination. There is no need, however, to predicate anything excessive in the size of the beings who have executed such stupendous irrigation-works, for, owing to gravity being less, a human being if placed on Mars would be capable of doing about three times as much work with the same effort which he would exert on our globe. The triangulation of the whole surface by irrigation-canals, traversing alike the deserts and the areas of permanent vegetation, pre-supposes, however, not only a knowledge of mathematics, engineering and agriculture, but clearly indicates that the Martian population has reached a high ideal of communism and political unity from which we are still far removed. The very flatness of the surface may have largely brought about this happy result in rendering communication easier by the cutting of canals for over 3,000 miles in a direct line. Moreover, the absence of any physical barriers, such as rivers and mountain-ranges, will have prevented that development of distinct nations and races, differing in language, customs and aspirations, which is so characteristic of our continents.

49, Blomfield Road, Maida Hill, London, W.  
July, 1897.

THE BLACK AUTOCOPYIST.—We have recently seen some beautiful pictures and other work produced by this simple machine, and its ally, the photo-autocopyist. In the hands of an amateur, pictures of natural-history objects or other drawings or photographs may be reproduced in numbers, for circulation among correspondents. To secretaries of scientific societies the machine is invaluable for sending out notices and reports, maps for excursions, etc., because of the simplicity and rapidity with which they can be produced. Some of the specimens which have been submitted to us are most artistic, and equal to first-class collotype pictures. The price and further particulars may be obtained from the Autocopyist Company, 72, London Wall, E.C.

## A JUNE RAMBLE.

BY ALFRED H. BASTIN.

WE are up early this morning, and out into the already glaring sunshine, on our way down the dusty road towards the railway station. The mist shrouding the hills across the valley speaks eloquently, to those who care to notice, of the exceedingly hot day before us. Just at present, however, the sun's ardent rays produce none save pleasurable sensations. There is the freshness of morning in the air, the heavy dew is still undried upon the grass, and the leaves of the elms and lime-trees by the road-side shine in the light as though they had just completed their morning toilet. The sunshine penetrates to the gloom of the station, and the polished copper and brasswork of the locomotive-engine catch the beams of light and reflect them with a dazzling brilliancy. Even the grimy, stuffy carriages look less uninviting than on a dull day.

Almost before we are aware of it, we have left the town, and are flashing past banks bright with a profusion of summer blossoms. The air coming in through the open window is laden with the sweet perfume of the grass and flowers. Would that we were capable of resolving this scent to its various origins—so that our minds might name each and realize the thousand and one odours which the flowers are for ever distilling into the atmosphere. The wild-roses are in full bloom, great bushes covered with the delicate pink and white blossoms, interspersed here and there by elder-bushes with flat trusses of tiny white flowers. The commonest blossoms on the banks are the moon-daisies, which form quite a "milky-way," dotted with bright dabs of scarlet which we know, as we speed along, to be poppies. An endless series of country sights flash past us. Green wheat-fields, variegated with great patches of yellow charlock, meadows crimson with sorrel or white with daisies. Occasionally a shorn hay-field, with the lines of dry grass browned by the heat of the sun. Here the workers lean on their great wooden rakes to gaze at the passing train, and the touches of colour supplied by the women's dresses lend life to the picture.

Thus the panorama trails behind until we reach the wayside station at which we alight. Passing out through the white gates of the level crossing, and down the little village street, with its irregular cottages and "Red Lion" Inn, we are soon in the lanes and on our way to the low-water meadows which are our destination, the object of this ramble being to secure a few specimens of the greasy fritillary butterfly. On our left, as we plod along, is a broad, shady ditch, containing a good

supply of water. Here, magnificent examples of water-dock are growing: great plants, four feet and even five feet high, with broad, dark-green, cool-looking leaves, which rest the eyes after the stretch of white, dusty road over which we have just passed. Let us stop to rest a moment on the bridge spanning the mill-stream. Long streamers of the water-buttermilk trail in the current, the little white blossoms studding the surface. Amongst these flowers dark-blue dragonflies dance heavily, seeming in momentary danger of a watery grave, yet always reaching a place of safety just as their wings appear to be giving out. Then to the top of the steep hill where is a common. The golden glare of the gorse, which some weeks ago made this spot such a glorious sight, is now past; some small clumps of heath are already in flower, and the pink patches enliven the darker tints of the flowerless gorse.

The path across the common leads us to a pine wood where Scotch firs, growing close together, form a most grateful shade. The air too is sweet and health-giving with the smell of the resin. High up, where the sunlight streams through the boughs, hundreds of small moths are dancing. Occasionally one comes down close to the ground, and this enables us to ascertain that they are bordered-white moths—a common species in fir woods. Underfoot is a thick carpet of dry brown fir needles, springy to the tread. Very little vegetation grows under the firs—probably more from the fact that little sunlight penetrates to the ground than from any directly harmful influences exercised by the trees themselves, as has sometimes been suggested. One plant, however, grows here in some profusion: this is the whortleberry, great patches of which are on every side, the green of their foliage heightened in vividness because of the dark tints all around. The path leads us out once more into the sunlight, and on down a rough, steep little lane with high hedges on either side. At the bottom of the hill is a tiny stream, spanned by a very rustic foot-bridge. Here the lane has dwindled into a mere path, and a few yards further on it ends altogether at a rough stile, over which are our water-meadows. These fields lie very low, between wooded hills, and, sheltered as they are from the winds, yet exposed to the full glare of the sun, form, as it were, a natural hot-house, highly productive of vegetable life, and where insects abound. Keeping along the edge of the fields, under the alder coppice and by the hedges, so that we may not harm the tall mowing-grass, we rig our nets

and catch the butterflies as they flit from flower to flower. In a very short time we come upon some *Melitaea aurinia*, or "Greasies" as they are popularly called by young entomologists, distinguishable by their low, fluttering flight amongst the grass stems.

After catching a few of these butterflies, however, it becomes plain from their damaged and rubbed condition that we are a week too late in our visit. We therefore leave them to reap to the full the joy which their short lives afford, and look around us for other objects wherewith to satisfy our desire for the beautiful. In truth we have not far to seek, for marvels of loveliness are on all sides. As we advance, bright, flashing, green tiger-beetles spring up from the bare, sun-cracked patches of earth and fly on in front with an activity equalling that of blue-bottle flies. They take short flights though, and soon pitch upon a resting-place a few yards ahead, only to rise again at our approach. Amongst the high grass and moon-daisies other butterflies besides the fritillaries are flitting or taking momentary siestas on the black heads of the plantain flowers or some other dainty couch. Here is the little tawny heath butterfly flapping along, and there a couple of "blues," azure above, but, when settled with folded wings, showing on the underside a beautiful pattern in tiny white and orange spots on a silver-grey ground. An occasional wood-white butterfly comes along the outskirts of the coppice, flying weakly, as becomes so delicately-formed a creature, and orange-tips, most beautiful of all British butterflies, sometimes stray from their beloved lanes to brighten these meadows with their presence. They work carefully and systematically along the hedges, as though they had lost something, and were going back along the path which they have already traversed to seek their property. No doubt the real object of this search is a wife, and the orange-tip does well to look circumspectly, for his sweetheart is not decorated with his rich orange colour.

Small wonder that the butterflies come to these fields, for there is sunny heat here, which to them is life, and besides there is a large choice of nectar as well. Turn where you will, flowers greet your gaze. Under the shelter of the hedge are tall foxgloves, with only the few of their lowest flowers open as yet, but with the spike of developing buds above, falling gracefully over to one side. Wild parsley and pink and white champions grow amongst the flowering grasses below. As we stroll along our feet are buried in more blooms: beds of white dutch-clover; patches of bird's-foot trefoil, the flowers exhibiting all shades of rich golden yellow and orange, occasionally almost crimson; spikes of blue bugle; trailing, clutching streamers of purple vetch; hawkweeds, some with orange-

coloured and some with lemon-coloured blossoms. Huge patches of swampy meadow are completely covered with yellow-rattle; and the usual bouquet of gorgeous-coloured field and marsh flowers might be gathered.

Let us sit for a while in this wild garden, under shelter of an oak-tree. It is about noontide now, and the heat is nearly at its worst. Gazing dreamily on this picture, an old question arises: How is it that the trees and the sky appear to us to be in perfect harmony, when artificial greens and blues in combination fail to satisfy our sense of the beautiful? We are unable to solve the problem, so we rise and make our way to the alder copse. The ground is moist, absolutely boggy in places, and the water soon finds its way over the tops of our shoes. This, however, is somewhat of an advantage than otherwise, for wet feet in summer-time are a luxury. The vegetation here is quite different from what we saw just now, only fifty yards away on the rising ground. Clumps of crimson ragged-robin are conspicuous in the open patches, and great spikes of the spotted orchids stand erect in the dryer spots. The delicately-scented fragrant orchid, with its high stem of tiny rose-coloured long-spurred blossoms is here too. The unopened portion of the spike bows over, much as do the foxgloves. A yellow iris, backed by its thick sword-like leaves, guides us, flag-like, to where a large clump of this plant is growing. There are many buds, but only a few are open as yet.

Jumping from tussock to tussock, we reach a dry patch where cotton-grass leaves fluff upon our lower garments as we brush through it; but we press heedlessly onward, for in the distance we have caught sight of a flower which we have not before seen growing here, the columbine. A beautiful plant it is, with its dark leaves and tall stalks, bearing rich purple flowers with yellow stamen tufts in the centre. These wild specimens are larger than many which we have seen growing in gardens.

Amongst the stoles of the alders the graceful fronds of the lady-fern are very conspicuous. They are of a delicate green, and are exceedingly beautiful to look upon, but as yet they are too young to pick. Carried in the hot hand in this sunshine, they would soon droop and turn black. They have a characteristic but pleasing odour, which is intensified when the leaves are bruised or broken. A cuckoo cries several times as he flies across the valley, and a chaffinch in a neighbouring oak gives out his monotonous, jerky song. The birds are becoming more active now that the heat is passing; but we are far from home, and must leave even such congenial surroundings.

Ivy House, New Road, Reading;  
July, 1897.

## FLYING-FISH.

By K. HURLSTONE JONES, M.B.

THE fact that there is a fish that can fly, as well as swim, is one that is brought home, even to those least interested amongst us, at a very early age, in a forcible way, through the medium of certain illustrated periodicals provided for the delectation and intellectual improvement of the Anglo-Saxon in his early youth. In these periodicals there appear mendacious woodcuts representing half-a-dozen glorified herrings soaring in the air, at a height of apparently about half-a-mile from the sea below. In a recent run of ten days from Madeira to Pará, I have had ample opportunity to observe the flight of these beautiful fish, and although I do not pretend to know very much about them, still such scraps of information as I have gathered may, perhaps, be of interest to some readers. The flight of the flying-fish is peculiar to itself, and although it does certainly bear a resemblance to that of some other animals, it is not quite like any of them. The fish, of necessity, only takes short flights—thirty or forty yards, I should say, is about the average. I have never seen one do more than a hundred yards at a stretch, and even then only with numerous dips into the water. The flight consists for the most part of a series of rapid dashes, with outspread fins, of lightning-like dives into the air, if one may use the expression. The fish apparently makes a rapid rush out of the water, and then spreading out its great pectoral and ventral fins, uses them like sails to keep it suspended above the water. It can, however, make use of the former pair of fins as true wings, and they can be actually seen to be in rapid motion whilst the fish is in mid-air. The flight is, perhaps, more like that of a swallow, when that bird is flying low over water, than any other creature; it is full of sharp corners and turns, though as a rule the flying-fish accompanies each change in direction by a preliminary dip in the water.

To see a shoal of flying-fish on the wing, or on the fin, to speak more correctly, is a most lovely sight, though no doubt, to one unaccustomed to it, the deep indigo colour of the ocean and the gorgeous tropical sunshine have much to do with the beauty of it. The brilliant glitter of the sun on the great outstretched fins and the beautiful blue of the back of the fish give them much the appearance of a flight of gigantic dragon-flies as they dash away with an occasional dip, just skimming the tops of the waves, till one by one they disappear with a sudden splash into their native element. Generally speaking, flying-fish are seen singly, or in little parties of two, three, or four, but shoals of forty, fifty, or even more

are not uncommon. They must be much more numerous beneath the surface, or else the fish must be able to swim as fast as it can fly, for fresh members keep leaping from the water to replace those which drop, until the course of the vessel leaves them out of sight. In the daytime the flying-fish never rises more than a few feet above the water; at night-time, however, when the lights are lit, they, like so many other animals, fly at them, and often land on the poop deck, a height of eighteen feet above the water, and occasionally they fall on the bridge, which is about seven feet higher.

There seems no doubt that the flying-fish is capable of directing its course in the air, even to a fine point. One night a fish the size of a mackerel came straight through the port of the chief engineer's cabin, whose room is situated in the alley-way. It flew with the rapidity of an arrow, almost striking him as he stood by his bunk, and then it struck the side of the engine-room ten feet further on, falling stunned on the deck. Now that port-hole was only twelve inches across, and is bisected by an iron bar, so that the fish, which evidently was attracted by the light, must have made an uncommonly good shot to have gone through out of the darkness, for it was a dirty night.

In sailing-ships, in which, owing to the length of their voyages, fresh provisions are apt to run short, it is a recognized plan to hang up a large net with a lamp behind it for the purpose of catching the fish and so obtaining a supply of fresh food. I have never seen this done, but I am told the plan succeeds admirably. As an article of diet the flying-fish is decidedly a success, especially at a time when fresh fish is otherwise unobtainable. Its flesh is firm and white, and in taste not unlike that of the trout, but drier. Most of the specimens that I have seen have averaged about seven to nine inches, and twelve inches is quite common, whilst individuals fifteen to twenty inches in length are occasionally caught. The fish itself has a back of a dark indigo-blue colour, and the under surface is of a silvery white, fading gradually into the blue above. The shoulders are exceptionally wide, as one would expect in a fish with such enormous pectoral fins, the muscles connected with which must be proportionally strong. The eyes are extremely large and very prominent. The great pectoral fins are each about half the length of the fish, or rather more. The rays near the periphery of the fin dichotomize into secondary, and again still more distally, quit

close to the margin, into tertiary rays. Between the rays is stretched the usual transparent membrane. There are also a pair of large ventral fins, medium ventral and dorsal small fins near the tail. The usual large first dorsal fin which one sees in most fish is conspicuous by its absence. The two flukes of the tail are unequal, but, unlike most fish which have unequal flukes, the sharks for instance, the lower is the larger in the flying-fish.

The flying-fish has a very tough skin, and it is quite easy to remove it and stuff with tow, but is pretty nearly impossible to prevent the scales, which are very large, from cracking off, which they do wherever the skin is grasped or bent. The sailors scrape out the flesh from an incision in the middle line of the abdomen, and then fill up with

tow, and after spreading the fins out with pins allow them to dry. Another plan is to gut them, spread out the fins with small pieces of wood and put them into the "harness" cask to get pickled with salt, then to dry them in the sun. The worst of all these plans is that the fish lose their lovely colours and become dull, ugly-looking objects, which convey no idea of their original beauty. Why these fish fly I do not know, but there seems much in support of the view taken by the sailors, that they do so to escape from their hereditary foes, the dolphins. They often get up just under the ship's bows, or on the beam, and flit away over waves as if to escape from an unknown danger in the shape of the steamer's hull.

*Pará; June 9th. 1897.*

## CONTRIBUTIONS TO THE LIFE-HISTORIES OF PLANTS.

BY THOMAS MEEHAN.

(Continued from page 39.)

### HONEY-GLANDS OF FLOWERS.

IT is impossible to take up any subject connected with the behaviour of plants without a thought of the wonderful labours of Darwin in the same line. We owe him warmest gratitude for the direction he has trained us to follow. But some of us believe that the great field of vision he opened up to us is broader than ever he himself suspected, and that many more behaviours of plants are to be seen and interpreted than it was given to him to behold and explain. It is, moreover, clear that the *a priori* line on which he started must naturally bias judgment. It is not in human nature to be free from such bias. Feeling that every act and behaviour of a plant must originate in a selfish effort for its own good, the doctrine of natural selection naturally followed. The natural condition of life being that of continual war, every effort of a plant was to secure some advantage in this great struggle. Whatever helped this view could not but be welcomed, even by one who was so unusually fair-minded at Darwin. Whatever did not accord with his premises could not be considered as of much importance. Some of us have departed from the path of our great leader. To us it seems that while selfishness is an undoubted condition of existence, self-sacrifice is equally a natural law. It appears to be the higher development of the original condition—the *raison d'être* why selfishness exists. Facts which Mr. Darwin would treat lightly we may be pardoned for desiring to see more clearly elaborated.

The honey-glands in flowers have been, in Mr. Darwin's view, so closely related to the encouragement of insect visitors, that their production where

they could have little reference to the fertilization of flowers is lightly treated. He refers<sup>(1)</sup> to an observation of Karr, that the bracteas of some orchids secrete nectar, that Fritz Müller has seen a similar behaviour in the bract of *Oncidium*, in Brazil, and that Mr. Rodgers had seen a similar secretion from the brace of the flower-peduncles of *Vanilla*. That he could have seen this frequently in the species of orchids under his own observation is probable. He names *Phaius* as one of the genera in which he examined the flowers for nectar<sup>(2)</sup>. I am sure I have seen honey-glands similarly situated in many orchids, but they are very evident in *Phaius grandifolius*, a common species under cultivation, and probably the one Mr. Darwin had under observation.

I have had before me for a couple of weeks past a Nepalese species not uncommon in gardens, *Cymbidium aloefolium*, in which the copious supply of nectar from the base of the bract, or rather from the main stem at this point, attracts general attention. It will be of interest to describe the development of the inflorescence in detail. The spike has sixteen flower-buds on it. The peduncles are at an acute angle with the main stem, and perfectly straight until the bud has reached its full size and is ready to expand. When this stage is reached the peduncle takes a horizontal position and then makes a twist, curving upwardly, and the labellum, which up to this time had formed the upper portion of the perianth, becomes the lower. Many days before this occurrence the nectar commences to ooze from

(1) "Fertilization of Orchids," chap. ix.

(2) *Ibid.*, chap. v.



the gland at the base of the bract. Long before the opening of the floral segments the globule has reached its full dimensions of two or three lines in diameter. It soon hardens on exposure to the atmosphere, and has a high degree of viscosity from its earliest appearance. Considerable force must be exerted in expelling it from the tissues of the plant. Mr. Darwin's explanation is that in these cases the excretion is for the sake of getting rid of superfluous matter during the chemical changes which go on in the tissues of plants. But as starch is necessary for storage, and plants generally have no superfluity of the article, why should the plant labour to form that which, in this case, must be the wholly superfluous article of nectar? To get over this difficulty, Mr. Darwin had already suggested that nectar was in the earlier ages of plant-life always superfluous. That insect life at first had no knowledge of its existence or value, and that, on discovering it, insects and flowers became gradually more correlated.

So far as we can now see, these secretions render the plant no service whatever in the great battle of its life, and this Mr. Darwin frankly owns. To him it is an act of excretion of useless matter. To us who believe that individual life is not wholly for itself, but that every act is of some use in the general economy of nature, the new field opened up is one of extreme interest. Observations in this beautiful field are too limited to warrant any general deduction as to the purpose of these stem-bearing glands. The object of this paper is to draw the attention of those who may have orchidaceous plants to a closer examination of their structure, and to encourage a record of such observations.

#### HYBRIDS IN NATURE.

Our gardens abound with hybrid plants. Although the gardener's skill originates them, there seems little reason why they should not occur in nature. The plant desired to produce seed has its flower opened by the hybridizer before it naturally expands; the anthers are removed before the pollen sacs are ruptured, insects are excluded, and the next day probably, when the stigma is receptive, the foreign pollen is applied. In this way hybrids are secured. From the ease with which hybrids are produced in this way arises the belief that hybridism in nature must be of frequent occurrence.

It is a matter of grave importance that we decide how far this belief is correct. Up to a period not remote, it was a belief that what we know as a species was always a species from the earliest epoch. When a distinct form came under observation that seemed not to have existed from the beginning, it was regarded as a hybrid. It would be accepted as a species, though deemed of

hybrid origin. Thus Linnaean nomenclature abounds in "*hybrida*" as a specific denomination. If it can be shown that these are not hybrids, but have been evolved from other species under some regular law of development, the importance of the question becomes apparent.

We now accept the doctrine of evolution as beyond discussion. Species do follow from other species as the world advances; but the old idea is still so prevalent, that many botanists who accept the facts of evolution in a general sense are very apt to regard any unusual departure as a case of hybridism. Our modern literature abounds in such instances. Supposed hybrids are being continually described as actual hybrids on no other ground than that they possess characters common to others already described.

If nature intended hybridity to be one of her handmaidens in the production of new forms, she has strikingly failed. Let us take the oak as an illustration. When the male flowers are at a certain stage, a slight jarring of a branch will cause the pollen to float away in little clouds discernible to the watchful eye. One may readily conceive what an enormous quantity of pollen must be carried from one tree to another by every sudden breeze. In our woods there are rarely less than two or three species in company. Not infrequently there are more, and these are usually blossoming all at one time. Hypothetically, one may argue that these gregarious species must receive one another's pollen, must cross fertilize, must result in a hybrid progeny in which every separate characteristic will be irretrievably lost. But the careful student of nature knows that this is not so. The seed collector goes into a wood which may contain white oak, black oak, scarlet oak, red oak, chestnut oak, swamp white oak, post oak, black-jack oak, scrub oak, as he may do along the Wissahickon, gather the acorns of each species under its particular representative, and plant them with the absolute certainty that they will be true to their several parentages. This could not be if the hypothetical proposition cited, of free inter-pollination, were an actual fact.

How, then, are we to account for the striking deviations from typical forms which we occasionally see? I have long believed that form is the result of various degrees of rhythmic growth. It is the mechanical result of varying degrees of energy. These results may be noted on a single tree. On the weaker branches of a white oak the leaves will be comparatively entire; on the stronger shoots, where growth-energy is rampant, the leaves will be deeply lobed. In mulberries these differences must be well known. The leaves on branches full of growth-vigour are lobed, but when this energy is somewhat spent, wholly entire leaves follow

Surely these facts must have come within the range of common observation.

Varying degrees of rhythmic growth may not always result in lobed leaves in its aspects of vigorous growth, or of entire leaves in its weaker ones, because other factors interfere. We may not know just what these incidental forces are, though we may feel sure they exist. For instance, on the common red cedar we may note two distinct forms of foliage; on the weaker, half-starved branches the leaves are like needles and resemble those of the common juniper, but on the more vigorous branches there are seemingly no leaves at all. We have to say "seemingly," for indeed there are really leaves, as really so as on the weaker ones, but the peculiar growth-energy of these more vigorous branches causes them to become connate with the stems. On a branch a year or two old we can easily separate these connate leaves from the true bark formed beneath.

That there is no necessity for bringing in hybridity to account for the occasional aberrations from the normal form we meet with is well known to those nurserymen whose business it is to raise trees in great quantities. There are just as many and just as striking variations among genera consisting of a single species, or of species wholly isolated from other species of the genus, as where there are several. The European oak, ash, linden, beech, and many others, furnish illustrations. The English oak, *Quercus robur* especially, will furnish scores of variations that have been selected from the seed-beds of nurserymen, and given distinctive names. Many of these differ from each other by characters quite as striking as those which distinguish American oaks from each other; but we know they are not hybrids because there was no other species with which they could intercross, and they are not regarded as species because of their derivation from *Quercus robur*. This would not be a true test of specific rank. It still savours of the old doctrine of the special formation of species, which we know is not true. With our modern experiences we may expect occasional wanderings from a general character as a result of an unusual expenditure of force. Usually these displays of energy are not able to maintain themselves. Seedlings fall back to the habits of their ancestors. If, however, they should be able to maintain themselves, they are entitled to rank as species. They are species and nothing else.

Seeing, as we must, that all this is so, and must be, why should we refer to hybridity to account for individual changes, especially as the warmest advocates of natural hybridity rarely get beyond "supposition" in any case?

(To be continued.)



NOTICES BY JOHN T. CARRINGTON.

*Electricity and Magnetism for Beginners.* By F. W. Sanderson, M.A. 245 pp. 8vo, with 116 illustrations. (London and New York: Macmillan and Co., Limited, 1897.) Price 2s. 6d.

The object of this book is to introduce boys to the general subjects treated in its pages; from them they may get a working knowledge of the application of electricity to man's requirements. Every experiment has been practically worked out by the author, and all appear to be within the reach of a beginner. We can recommend the work for schools and young people who are prepared to help themselves to such necessary knowledge.

*British Game Birds and Wild Fowl.* By BEVERLEY R. MORRIS, M.D. Revised by W. B. TEGETMIER, F.Z.S. Parts iii. and iv. Super royal 8vo, with coloured plates. (London: John C. Nimmo, 1897.) Price 2s. 6d. per part, net.

Part iv. completes one third of this handsome work, which we have already noticed in May and June last. The parts before us contain nine plates between them. They finish the grouse, partridges and quails, and end with the two species of bustard, now so rarely observed in Britain as casual visitors. We should like to have seen some more notices of the occurrences here of these rarer birds since the publication of the first edition of the work, as it is well to have all information about them as complete as possible.

*Mineralogical Geology: A Synopsis for the use of Students, to accompany W. and A. K. Johnston's Geological Map of the British Isles.* By ALEXANDER JOHNSTONE, F.G.S. 198 pp. 8vo, and 14 plates. (Edinburgh and London: W. and A. K. Johnston, 1897.) Price (with coloured map) 23s.

This useful book is a supplement to the handsome map, which measures fifty inches by forty-three inches. The map was originally compiled by Sir Archibald Geikie, LL.D., the Director-General of the Geological Survey of Great Britain; but it has been revised and extended by Mr. Alexander Johnstone, F.G.S. It forms, with its numerous sections, as complete a map for geological purposes as one could desire, and should be hung in every schoolroom in the kingdom. With its aid and that of any good text-book on geology an intelligent person could instruct schoolboys and girls sufficiently to let them understand the origin of their respective neighbourhoods. The accompanying book gives a sketch of the science of mineralogy, with localities for minerals in Britain. Many persons who know little of the subject will find pleasant surprises in store for them, when they discover how many rare minerals and gems are within their reach in these islands. Being alphabetically arranged, they will soon know that we have, among many others, amber, amethysts, beryl, cat's-eye, chrysoberyl, garnet, jasper, moonstone, moss-agates, onyx, opals, topaz, besides gold, silver, platinum, copper, etc., among the precious metals.

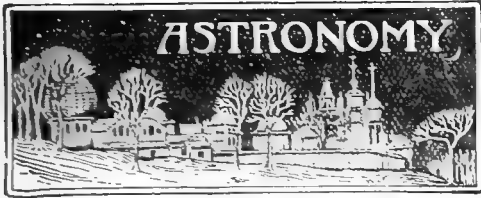

CONDUCTED BY FRANK C. DENNETT.

		Rises.		Sets.		Position at Noon.	
		h. m.	h. m.	h. m.	h. m.	R.A.	Dec.
Sun	5 ...	4:32 a.m.	7:40 p.m.	9:3	16° 51' N.		
	15 ...	4:47	7:21	9:41	13° 54'		
	25 ...	5:3	7:0	10:18	10° 35'		
Moon	5 ...	1:20 p.m.	5:38 p.m.	9:46 p.m.			
	15 ...	8:1	1:53 a.m.	8:14 a.m.			
	25 ...	1:51 a.m.	9:49	5:49 p.m.			
		Rises.		Sets.		Position at Noon.	
		h. m.	h. m.	h. m.	h. m.	R.A.	Dec.
Mercury	5 ...	1:23 p.m.	2 <sup>h</sup> 7	10:20	11° 22' N.		
	15 ...	1:57	3 <sup>h</sup> 1	11:13	4° 28'		
	25 ...	1:39	3 <sup>h</sup> 5	11:56	1° 43' S.		
Venus	5 ...	9:2 a.m.	0 <sup>h</sup> 0	5:59	21° 9' N.		
	15 ...	9:10	8 <sup>h</sup> 5	6:47	21° 18'		
	25 ...	9:19	7 <sup>h</sup> 8	7:35	20° 33'		
Mars	15 ...	2:1 p.m.	1 <sup>h</sup> 9	11:37	3° 16' N.		
Jupiter	15 ...	1:28	11 <sup>h</sup> 5	11:5	7° 3' N.		
Saturn	15 ...	5:53	7 <sup>h</sup> 8	15:30	16° 57' S.		
Uranus	15 ...	5:53	1 <sup>h</sup> 8	15:31	18° 50' S.		
Neptune	15 ...	7:50 a.m.	1 <sup>h</sup> 2	5:26	21° 52' N.		

MOON'S PHASES.

	h. m.		h. m.
1st Qr.	Aug. 5 ... 6:25 p.m.	Full	Aug. 12 ... 2:23 p.m.
3rd Qr.	.. 20 ... 8:29 a.m.	New	.. 28 ... 5:29 a.m.

In perigee, distant 229,100 miles, August 7th, 9 p.m.; in apogee, distant 251,200 miles, August 20th, 9 a.m.

CONJUNCTIONS OF PLANETS WITH THE MOON:

Aug.	Planet	Time	Position
1	Jupiter*	11 a.m.	planet 4° 37' N.
1	Mars*	4 p.m.	" 4° 41' N.
6	Saturn*	3 p.m.	" 2° 13' S.
24	Venus†	7 p.m.	" 2° 31' S.
29	Jupiter*	5 a.m.	" 5° 2' N.
30	Mercury**	7 a.m.	" 1° 59' N.
30	Mars††	7 a.m.	" 5° 30' N.

\* Below the horizon in England. † Daylight.

SUN.—No spots were noticed on the disc for about three days in June (17th, 18th and 19th), but since then there have been several small spots, one or two of considerable interest.

MERCURY is an evening star, reaching its greatest elongation east, 27° 12', at 5 p.m. on 26th, when he sets about thirty-two minutes after the sun. He cannot be said to be in good position for observation.

VENUS is a splendid object in the north-east as a morning star, rising at about 1 a.m. on August 1st, and near 1:30 on the 31st.

MARS, JUPITER and NEPTUNE are too near the sun for observation. The conjunction of Jupiter and Mercury at 6 a.m. on the 13th, the latter 1° 14' S., unfortunately happens in broad daylight, and when both the planets are below the horizon.

SATURN is still a splendid object, but must be looked for quite early in the evening. He sets at 11:22 on the 1st, and at 9:25 p.m. on the 31st.

URANUS is poorly placed for observation away south of Saturn, being in conjunction with it, 1° 48' S., at midnight on the 25th.

METEORS should be looked for on August 3rd, 5th, 7th-13th, 15th, 19th-22nd, specially 10th, but many meteors may be expected on all the

dates given in the first half of the month. Perseus seems the portion of the heavens whence most of these bodies radiate.

RED STARS IN POSITION DURING AUGUST.

	R.A. h.m.	Dec.	Magnitude.
B. 579 Cephei	21.10	59° 37' N.	7.5
u	21.40	58° 14' N.	4-6
B. 599 "	21.53	63° 3' N.	5.7
S	21.37	78° 5' N.	7.4-11.5
B. 587 Cygni	21.32	44° 50' N.	6.7
B.A.C. 7219 "	20.44	45° 8' N.	7.0
Cygni	21.40	37° N.+	7.0

HOOR-GLASS SEA ON MARS.—M. E. A. Antoniadi contributes an interesting article to "Knowledge" for July, in which he seems to prove conclusively that considerable change has slowly taken place on the western part of this marking during the present century. It appears as if the "sea" has gradually encroached upon the land.

JUPITER'S SATELLITES.—Mr. Douglas, of the Lowell Observatory, has come to the conclusion that the third moon rotates on its axis in 7d. 5h., nearly corresponding with the period of its revolution, 7d. 3h. 42m. 33.4s. The fourth also very closely approximates the time of rotation with that of revolution.

THE AMERICAN NAUTICAL ALMANAC has a new Superintendent, Professor W. W. Hendrickson, head of the mathematical department in the Naval Academy at Annapolis for twenty-four years, having been appointed in place of Professor Newcomb, who had retired.

DR. J. FRANZ has been appointed Professor of Astronomy in the University of Breslau and Director of its observatory. He has been Assistant Professor of Astronomy at Königsberg.

THE PHOTOGRAPHIC ATLAS OF THE MOON, consisting of enlargements, by Dr. Weinek, of photographs from the Lick, Paris and Arequipa Observatories, must be ready for commencing publication, for its prospectus has been issued. It is to be hoped that the work will be completed in spite of its considerable price of £10; none too long, however, for the work represented.

SUNSPOTS.—An illustrated paper on "The Umbral Protrusion of Sunspots," communicated to the British Astronomical Association by Mr. F. K. McDonall, of the New South Wales Branch, and read at the meeting at Essex Hall on June 30th, led to an interesting discussion by Captains Noble and Steele, Mr. Maunder and Miss Brown. The opinion generally expressed was that sunspots in section were very like lunar craters, only proportionately much more shallow. So much so is this the case that the centre of the dark umbra, or floor, is often elevated above the wall.

MR. ALVAN G. CLARK, the famous optician, has, we are sorry to hear, passed away, at the age of sixty-five. He was born in Massachusetts, at Fall River. He worked with his father, entering the firm upon leaving school. The 26-inch objective at Washington, 30-inch at Pulkova, and 36-inch at the Lick Observatory were the great works of the firm until the great Yerkes glass took the first place. He used the glasses as well, and with one he discovered the companion to Sirius, for which the Paris Academy of Sciences awarded him their Lalande gold medal, in 1862. The Yerkes glass is not in regular use yet, owing to the mishap to the elevating floor of the observatory.



THE next Congress of the French Society for the Advancement of Science will be held at Saint Etienne, from August 5th to 12th next.

A BILL to repeal the law providing for the payment of a bounty on the heads of English sparrows was defeated in the Michigan Legislature on April 16th.

THE Wart's Travelling Scholars' Fund, of Cambridge University, has made a grant of £300 to Dr. Haddon, for an anthropological expedition to the Torres Straits.

THE death occurred in April of Dr. V. Lemoine, a member of the Council of the Zoological Society of France, who was well-known for his studies of the fossil fauna of Cernay.

THE June number of the "Geographical Journal" gives a valuable physical map of the North Polar regions, by Mr. J. G. Bartholomew; it includes Dr. Nansen's and all other recent discoveries.

A GENERAL index to the seven volumes of the defunct "Insect Life," 1888-95, has just been published in a limited edition by the Division of Entomology, U.S. Department of Agriculture, Washington.

IN the "Irish Naturalist" for July, Mr. G. P. Farren records the collecting of *Helix arbustorum* in the neighbourhood of Multyfarnham, co. Westmeath. It has not been obtained from that part of Ireland previously.

AMONG other subjects treated at the meeting of the French Association for the Advancement of Science, we observe the disappearance of the freshwater crayfish in France, and its causes; also their replacement by the American *Cambarus*.

AT the meeting of the Zoological Society of France, held June 22nd, the Secretary announced that the Society had received the complete collection of the publications of the "Challenger" expedition given by the English Government.

WE have to announce the death of Mr. Daniel Muller, a distinguished entomologist and excellent collector. He was born in Alsace, but settled in Barcelona early in life. He devoted himself chiefly to the study of the Coleoptera of Catalonia, of which he leaves a very fine collection.

MESSRS. JONES AND EVANS, booksellers, 77, Queen Street, Cheapside, E.C., have sent us their special catalogue of "Choice Books," many of which are also very scarce. We often visit this shop on account of the pleasing editions Mr. Evans somehow has a knack of acquiring.

"SCIENCE" for June 25th has an important article on "The Influence of Environment upon the Biological Processes of the various Members of the Colon Group of Bacilli," by Dr. Adelaide Ward Peckham. It is an account of the results obtained from experiments and researches made by Dr. J. S. Billings and Dr. S. Weir Mitchell, who were assisted by a grant from the Bache Fund of the Smithsonian Institution.

THE Hull Scientific and Field Naturalists' Club, which is affiliated with the Yorkshire Naturalists' Union, has so rapidly increased its membership that the society has had to remove to larger premises, at 72, Prospect Street, Hull. The club will hold an exhibition early next winter. The Hon. Secs. are Messrs. F. W. Fierke and T. Sheppard.

THE Commission which, under the direction of Professor Koch, was appointed to investigate the origin of the plague bacillus in India, has issued its report. It states that the plague bacillus remains undeveloped in oxygen and has a very brief vitality outside the human body. Only isolated cases of the plague were observed by the Commission among people living out of doors, while among those who remained in houses, the epidemic was rife. The system of inoculation applied by Prof. Haffkine showed great protective results.

WE understand that a new scientific series, entitled "The Progressive Science Series," will be published during the autumn by Messrs. Bliss, Sands and Co.; Mr. Beddard, F.R.S., will be the editor. Among the authors and volumes in preparation are: Professor Cope on "Vertebrate Palaeontology"; Dr. Geikie on "Earth Structure"; Dr. St. George Mivart on the "Groundwork of Science"; and Prof. Bonney on "Volcanoes." The character and scope of these volumes will be "progressive" as opposed to a series whose object was merely historical and expository.

IT will be remembered that we printed in these pages (vol. iii., p. 85) a short account of the prospects of the success of the Andrée Balloon Expedition to the North Pole. We observe that Herr Andrée ascended with his balloon on Sunday afternoon, July 11th, at 2.30 o'clock. The balloon, named "The Eagle," travelled in a north-north-easterly direction from its starting-point on Dane's Island, at a speed of about twenty-two miles per hour. The distance from Dane's Island to the North Pole is about 617 miles, and the journey from the Pole to the nearest known land beyond is quite as far. He is accompanied by Drs. Strindberg and Fraendbel.

AN Antarctic Conference was held in the rooms of the Royal Geographical Society in London, on July 4th. The object was to bring the subject of Antarctic Exploration before the Australasian premiers visiting London in connection with the Jubilee. Among the speakers in favour of the proposal for further exploration in those regions were the Duke of Argyll, Sir Joseph Hooker, Professor Rucker, Lord Lothian, and several of the premiers. The President of the Royal Geographical Society said that Society was prepared to contribute £5,000 to further the work, if each Australian Colony would do the same.

AMONG the many deputations bearing Jubilee congratulations which have been presented to Her Majesty the Queen, was one, on July 15th, from the Royal Society, consisting of Lord Lister, the President; Sir John Evans, the Treasurer; Professor Michael Foster and Professor Rucker, Secretaries; Professor Rt. Bellamy Clifton, Sir William Huggins and Mr. W. T. Thiselton-Dyer, Vice-Presidents; Sir Joseph Hooker, Lord Kelvin and Sir George Stokes, Bart., Past-Presidents; and Mr. W. F. Harrison, Assistant Secretary. The President, Treasurer and Professor R. Bellamy Clifton had the honour of kissing Her Majesty's hand.



**FLOUNDERS IN FRESH WATER.**—I am told that the ordinary flounder is found in our rivers a long way beyond the influence of the tide, and also that it may easily be kept in freshwater ponds, where it will live and thrive on the snails and small crustaceans inhabiting the water. How far this may be correct I do not know, and I should like to hear the experience of such as have a special knowledge of the subject. I want, if I can, to cultivate the flounder in my large freshwater aquarium, situate in my fernery, and having a window looking into my dining-room. I hope some of your numerous readers may be able to give me the desired information.—*Henry J. Barber, Brighouse, Yorks. : July 9th, 1897.*

**ABNORMAL WALNUT-LEAF.**—The elongated elliptical leaves of the walnut tree (*Juglans regia*) are in normal cases arranged in an opposite, or nearly opposite, manner, with a terminal solitary leaf on gracefully drooping branches. In a specimen I recently obtained from a garden near Maidenhead, however, this terminal leaf is replaced by two leaves united half-way down by their inner margins. One of these is very nearly half as broad as its companion at the point of conjunction. The midribs diverge from the end of the twig without any distinct petiole, the blade of the larger leaf running about half an inch further down the twig than that of the other.—*F. P. Perks, 41, St. Martin's Lane, London, W.C.*

**HEDGEHOGS CARRYING FRUIT.**—Have naturalists ever decided the question whether hedgehogs do in reality carry fruit impaled on their spines, or whether the assertion that they do so is a mere folk-tale? I was told only a few weeks since by an intelligent working-man that when he lived at a situation in North-east Lincolnshire he saw one of these animals carrying apples in this manner, several times, in his employer's orchard. A pair of hedgehogs inhabited the place with their young, and not only he himself but other people used to watch the old ones transporting apples on their prickles. In Lincolnshire, when a man is ruffled in temper, it is sometimes said, "he has gotten his back up like a hedgehog going crabbing"; for hedgehogs are supposed to be very fond of the frost-mellowed fruit of the crab-tree and to carry it to their nests, hunching up their backs in a peculiar manner as they do so.—*Mabel Peacock, Kirton-in-Lindsey.*

**"SCIENTIST'S" NATURAL HISTORY.**—We are indebted to our correspondent, Mr. Wheeler, for the following cutting from a leading Bristol paper in July. It appeared in a letter on the prosecution of some fishermen for taking fish in the close-time: "I was highly amused and edified this evening to see in the 'Bristol Evening News' the prosecution of several persons for fishing during the close-season in the Froom at Eastville. Now the ed is not strictly speaking a fish, but belongs to the anguilliform, that is, a serpent or snake, and yet these poor men were convicted and fined for wasting their precious time endeavouring to hook

these serpents in such a quagmire as the Froom at Eastville. (Signed) Oscar S. Sage, Naturalist." Surely the editor of an important newspaper could not have seen this effusion before it appeared, or he must have known better than to pass it. Another contemporary actually quotes the following string of inaccuracies as an example of the work of a true naturalist. It occurs in a review of "On English Lagoons," recently published in cheap form by Mr. David Nutt: "The weather continued so bad that I brought my cruise to a close, and as I stepped out of my ship, on the last day of August in the drizzling rain, my little sedge-warbler jumped upon a reed and began to sing joyfully, for his family was now strong on the wing. I stopped, took off my hat, saluting the plucky little bird, wished himself and family a safe voyage across the seas. As I walked up the wall, masses of thistle-down were blowing across the marshes, an unfailing sign of autumn, and the last marsh-note I heard as I rode off was the farewell song of the brave little warbler." It is hardly necessary to remind our readers that reed-warblers, like others of their class, cease singing after the incubation of the eggs is over, or that thistle-down does not float in the air in drizzling rain or during bad weather, such as the author describes in his first line quoted. It is well to remember facts when trying to blend Art and Nature.—*John T. Carrington.*

**MARINE MOLLUSCA OF NORTH DEVON.**—A few notes may be of use to anyone interested in shells who purposes to spend a holiday in North Devon. At Lynmouth, *Purpura lapillus* are small and thick, and *Trochus lineatus* very massive on account of the lack of shelter and the force of the waves. As there is practically no sand between Lynmouth and Morte Point, the marine shells are few. I only found eleven species, and of these three did not occur out of one cove at Watermouth. South-west of Morte Point are several sandy bays. Of these the first, Morte Bay, is locally well known, on account of the Barricane Beach. This is an accumulation of shells, mostly broken, and is no doubt due to the set of the currents, which wash up all the shells into a space of about two hundred yards. Beyond this small area there are few or hardly any shells on the shore of this bay. My list of species for this spot was thirty-seven, but it is probably far from being complete. *Natica catena* seemed to be the most abundant shell. About six feet above high-water-mark of spring tides I noticed what seemed to be a "raised beach." It contained nearly all the species to be found lower down on the shore, and also seven others, which I did not see elsewhere, *Arca tetragona* being noteworthy; besides these there were eight species of landshells mixed with the marine. A few miles south-west of Barricane is Saunton, where there is a fine stretch of sand running in front of Braunton Burrows. Quantities of shells are to be found on the shore here, but not so many species as at Barricane; I noted thirty-one in all. *Cerastisolen legumen* was abundant, and *Actacon tornatilis*, large specimens of *Philina aperta*, *Natica alderi* and *Macra stultorum*, var. *cinerea*, were also to be had. Both Saunton Sands and Barricane would be well worth visiting after stormy weather. A list of the landshells of Ilfracombe and neighbourhood was published by Mr. J. R. B. Tomlin, in "Journal of Conchology," vol. v., page 181. The only additions I can make are *Helix a-persa*, var. *minor*, at Hele Bay, var. *conoides*, also at Hele Bay, and var. *exalbida* at Woolacombe Bay. *J. E. Cooper, Southwood Lane, Highgate, N., July 3rd, 1897.*

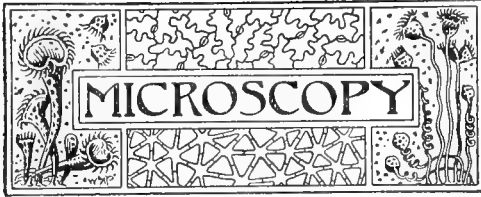

CONDUCTED BY J. H. COOKE, F.L.S., F.G.S.

To whom Notes, Articles and material relating to Microscopy, and intended for SCIENCE-GOSSIP, are, in the first instance, to be sent, addressed "J. H. Cooke, Thorndale, Lincoln."

THE SENSES OF INSECTS.—"The Senses of Insects" formed the subject of one of the last addresses to the Columbian University that was delivered by the late Professor V. C. Riley. After

distances. The highly-developed and delicate antennae in the male *Chironomus*, for instance, may be likened to an external brain, its ramifying fibres corresponding to the highly complicated processes that ramify from the nerve-cells in the internal brains of higher animals, and responding in a similar way to external impressions."

BRITISH FRESHWATER MITES.—In mounting these and other minute Acarids it will be found best to kill the insects in hot water, which causes them to expand their legs, so that when mounted these appendages can readily be studied. If mounted living the legs are almost invariably curled up under the body and cannot be seen. This method may also be used in the case of other minute insects.

PRESERVING POND GATHERINGS.—Those who are desirous of preserving their pond gatherings for examination during the winter months may be

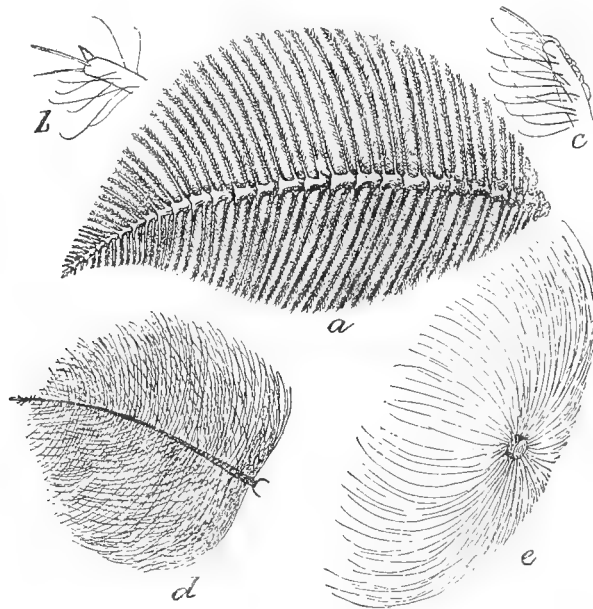

SOME ANTENNAE OF INSECTS.

*a*, *Telr polyphemus*, male,  $\times 3$ ; *b* and *c*, tip of rays of same, still more enlarged; *d*, *Chironomus*,  $\times 6$ ; *e*, section of same, still more enlarged (original).—*Insect Life*.

dealing elaborately with the more obvious senses of hearing, sight, smell, taste and touch, he proceeded to speculate on their possession of a sixth sense, an intuition, essentially psychical, by means of which insects make arrangements for the government and safety of their colonies and communicate one with another even when separated by considerable distances. This sense he considers to be a vibratory one, and it is located in the antennae. "No one," he says, "can study the wonderfully diversified structure of the antennae in insects without feeling that they have been developed in obedience to, and as a result of, some such subtle and intuitive power as this of telepathy. Every minute ramification of the wonderfully delicate feelers of the male mosquito in all probability pulsates in response to the piping sounds which the female is known to produce, and doubtless through considerable

interested to know that rotifers retain their vitality for many months if carefully dried. To do this they should be placed on paper and slowly heated in an oven, the temperature of which may be raised to as much as 200 degrees F. without doing them harm. When required for use they may be revived by placing them in water.

MOUNTING WINGS.—The following method of mounting wings for studying venation is described by Mr. Howard in "Insect Life." The wing is removed and mounted upon a slide in Canada-balsam, which should be preferably rather thick. The slide is then held over the flame of an alcohol lamp until the balsam spreads well over the wing. Just as it is about to enter the veins, however, the slide is placed upon ice. This thickens the balsam immediately and prevents it from entering the veins, which remain permanently filled with air, and appear black by transmitted light.

**MICROSCOPIC FUNGI.**—When one remembers the number of naturalists' or microscopical societies that exist in Britain, it is a matter for wonder that some systematic work is not done by them. In plant parasites there is a wide field for investigation and one which, if taken up seriously by microscopists, would be productive of results of real scientific and utilitarian value. These parasites have been divided into two groups, viz.: the **EPIPHYTAL**, which includes the fungi, which establish themselves on the green parts of plants and destroy them by a kind of suffocation, and the **ENDOPHYTAL**, those which originate within the tissues of their hosts, e.g. the Peronospora or potato-rot. Much valuable work has been done in showing the connection between the minute organisms, or Schizomycetes, and the plant diseases, but very much remains to be done; and just now, when "wheat rust" and Peronospora are so prevalent, an opportunity is afforded, by a

Fauna," which appears in the current issue of the "Transactions of the Manchester Microscopical Society," Professor Hickson suggests that the great variety of the patterns of the hooks, tubercles and other protuberances which the shells possess, that enclose the eggs of *Hydra*, the gemmules of sponges and the statoblasts of Bryozoa, is due to the many ways in which these organisms may become attached to the skin, feathers or scales of the animal chiefly concerned in their transportation from place to place. No experiments have been tried to prove this point; the remarks are, nevertheless, very suggestive. The same publication contains an interesting article by Professor F. E. Weiss on "The Life of a Diatom."

**RECENT RESEARCH IN FORAMINIFERA.**—In the Rend. Acc. Sc. Bologna, 1897, Dr. C. Fornasina contributes an article, "Note micropaleontologiche," in which he shows that *Nautilus granum*, Lin., and *Marginulina spinulosa*, Costa, are identical, and he

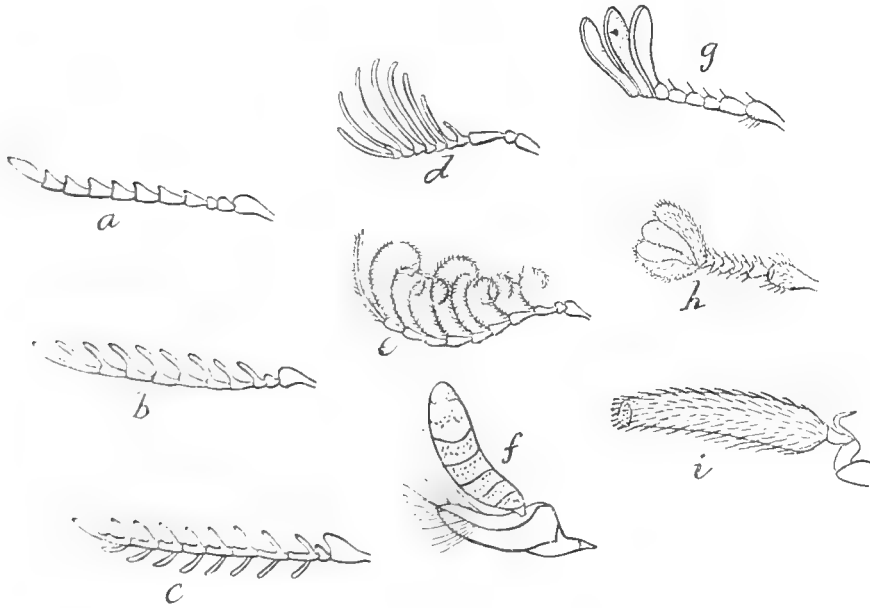

SOME ANTENNAE OF COLEOPTERA.

a, *Ludius*; b, *Corymbites*; c, *Prionocyphon*; d, *Acneus*; e, *Dendroides*; f, *Dineutes*; g, *Lachnosterna*; h, *Bolbocerus*; i, *Adranes* (after Le Conte and Horn). All greatly enlarged.—*Insect Life*.

study of these well-known forms of disease, for the practice of methods and the acquiring of information that will be valuable in the working out of the life-history of those fungoid diseases that are more obscure.

**LIFE-HISTORY OF MEALY BUGS.**—Greenhouses and gardens form prolific hunting-grounds for the micro-entomologist. The great prevalence this year of the mealy bug (*Dactylopius destructor*) would seem to suggest that there is still much to be done in the study of the life-habits of this minute pest. The female usually lays about 400 eggs, each of which is of a light straw colour and is about 0.25 mm in length. The white floccose network of wavy threads is spun for the purpose of protecting the eggs, and if this be removed and carefully opened, ample material for study will be obtained.

**DISTRIBUTION OF HYDRA.** In the course of an article on "The Distribution of the Freshwater

also demonstrates the affinity that exists between *Reophax compressus*, Goës, and *R. papillosus*, Neug. He has studied the specimens in the original collection of Costa, now in the Naples Museum, and concludes that *Biloculina circumclausa*, Costa, is identical with *B. depressa*, d'Orb, and that *Nodosaria clava*, Costa, is the same as *Clavulina communis*, d'Orb. He gives an illustration of an example of *Sagvina columellaris*, Brady, with a fissile aperture, which was collected by Professor Simonelli from the Neocene of Vigoleno in Piacentino.

**ROTIFERIAN SPECIE MONGERS.**—The list of new rotifers which appears in the current number of the "Microscopical Journal" bears strong testimony to the energy which is being displayed by the manufacturers of species. It contains 109 new names, a large proportion of which has been given to specimens for points of form or structure so insignificant, that the author, Mr. C. F. Rousselet,



waxes indignant. He pertinently remarks that if all dogs that one meets were differentiated and named on the same principle, "one would have to make a distinct species of every *Canis familiaris* living."

**SHEPHERD'S PURSE.**—The leaves of this weed (*Capsella bursa-pastoris*) have hairs in the form of a cross, and when mounted they are equal in effect to *Deutsia* as an opaque object.

**A TISSUE BEDDING.**—A good "bedding" for delicate tissues may be made by mixing beeswax and olive oil in equal parts. The tissue is placed in a tube and the fluid "bedding" is poured in around it. The ordinary botanical section-cutter may be used.

**PREPARATION OF OVA FOR MICROSCOPE.**—In the preparation of the ova and fry of fish for microscopical examination, the material for dissection should in the first place be put in a solution of chromic acid and allowed to remain there for at least a fortnight. If high powers are to be used glycerine should be avoided, as it tends to give the material a bluish-white tinge. The chromic acid imparts a rich yellow colour to the substance and renders it firm and solid, and what is of the greatest importance, it does not give rise to shrinkage.

**INFLUENCE OF LIGHT ON FUNGI.**—In the "Annales des Sciences Naturelles Botaniques" for 1897, M. A. Leudner records the results of a series of experiments on the effect of the access and withdrawal of light on a variety of fungi grown on different media. All the Muscorini examined developed sporanges under the influence of light when grown on solid sub-strata; in liquid media the results varied with the species. In the case of the conidial forms of the Ascomycetes, conids were invariably formed under the influence of alternate day and night; under continuous light the results varied with the species.

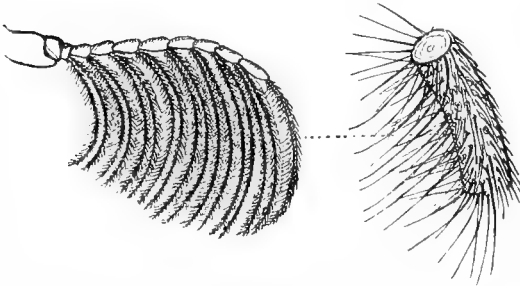

ANTENNAE OF MALE PHENGOIDES WITH PORTION OF RAY.  
Greatly enlarged (original).—*Insect Life*.

**REPRODUCTION OF DIATOMS.**—Mr. G. Murray records in the "Proceedings of the Royal Society of Edinburgh," some observations on the propagation of pelagic diatoms found off the coast of Scotland. In examining *Biddulphia mobilis* he discovered cysts within the parent cell with only slightly silicified membrane and destitute of the characteristic spines. These cysts appear to have the power of dividing and multiplying before assuming the likeness of the parent. A like arrangement was observed in *Coscinodiscus concinnus*, but in that species the cells divide before the

production of the cysts. It is not infrequent to find the young colonies of *Coscinodiscus* in packets of eight to sixteen. The membranes of these young colonies are very slightly silicified, and are therefore capable of increasing in size. A similar formation in packets, with like numbers, was found also in several members of the genus *Chaetoceros*.

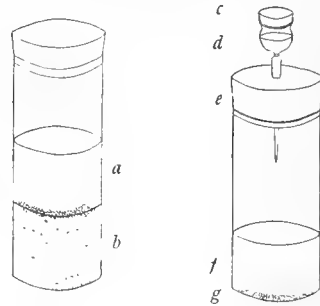

No. 1.

No. 2.

**MOUNTING CHARA.**—MR. A. FLATTERS' SYSTEM.

Method of graduating delicate objects through alcohol to oil of cloves. No. 2 tube allows one drop of oil to pass to the specimens every sixty seconds.

a, Alcohol; b, oil; c, cover-cap; d, oil-cup  
e, cork; f, alcohol; g, specimens.

**MOUNTING CHARA.**—In reply to a query which was sent by one of our readers requesting to know what is the best medium for mounting the reproductive organs of *Chara* to show clearly all details as a transparent object, Mr. A. Flatters, 16, Church Road, Manchester, writes: "The fruit of *Chara* is good when mounted in glycerine jelly. After cleaning place in 92 per cent. alcohol for several hours. Transfer into equal parts of spirits and glycerine for several hours longer, after which pour off nearly all of the mixture and add pure glycerine at intervals till the glycerine becomes concentrated. Mount the object in glycerine jelly in a cavity slip just deep enough to take it without pressure. A second method is in balsam, as follows: After cleaning, graduate through 25 per cent., 50 per cent. to 92 per cent. alcohol and allow to stand in the last strength for several hours. Take a tube and put in it oil of cloves. On the top of the oil pour a little absolute alcohol. Immerse the specimen gently in the alcohol and allow it to sink to the bottom of the tube. When clear mount in balsam and benzole. If the objects are placed direct from the spirits into the oil of cloves they will shrink up and be spoiled, hence the *graduating method*. To see the antheridia properly sections ought to be made." Mr. Flatters, who is one of the most successful mounters in the North of England, is prepared to supply readers with mounts of this or of any other histological or botanical object.

**ERRATA.**—In consequence of the miscarriage of proofs, the paragraphs on Foraminifera and *Vaucheria* (page 58) in the July number were not revised. For *Revista* read *Rivista*; *Rhisopoda* read *Rhizopoda*; *conoscienva* read *conoscienza*; *terriaria* read *terziaria*; and in latter read the Greek  $\mu$  to denote one-thousandth of a millimetre instead of mm., as there used.—ED. S.-G.





CONTRIBUTED BY FLORA WINSTONE.

REVUE LINNÉENNE (Lyons, June, 1897). This number contains a description of a new species and genus of marine shell from the Atlantic, south of Portugal, dredged at a depth of 600 fathoms. It is named *Assiminopsis abyssorum*, Loc. The article is by M. Arnould Locard. The species is nearly allied to *Assimina eliae* of Paladilhe.

ACADEMY OF NATURAL SCIENCES, PHILADELPHIA.—Among the later papers read before this academy is one upon "Plant Monstrosities," by Ida A. Keller, and an important one by Henry A. Pilsbry on "New Species of Molluscs from Uruguay." They are part of the material obtained at Maldonado Bay, by dredging in from three to six fathoms, by Dr. William H. Rush, U.S.N. These descriptions appear to be in connection with a paper on this collection which appeared in "Nautilus" for May of this year. The region from which these shells were obtained has been little explored and proves to be rich in species.

"THE OSPREY" (Galesburg, Ill., May, 1897). This is No. 9 of a new ornithological publication which we have previously noticed. It is prettily produced and elegantly illustrated. It refers largely to the birds of North America, and consists of short articles and notes. Among the latter we find a record, but unfortunately without date, beyond "Friday afternoon," stating that off Cape Mendocino, which we believe is a headland of California, the steamship "Walla Walla" encountered hundreds of humming-birds at sea which settled in numbers upon the ship. Then, the account continues, "the tiny visitors were so hungry that they attacked the officers and passengers, boring their needlelike bills into the flesh. The ladies wearing millinery of artificial flowers were driven to their state-rooms by the persecution of these birds!"

BULLETIN DE LA SOCIÉTÉ ZOOLOGIQUE DE FRANCE (Paris, March-April, 1897). Dr. L. Joubin, of the University of Rennes, contributes "Observations on some Cephalopods from the Museum of Moscow." The chief interest of this article lies in the increased knowledge of the geographical distribution of a few little-known species. M. Victor Fatio has an article on "Some Ornithological Particulars of Mount Salève." Mount Salève is a small mountain upon the Swiss frontier, about one hour from Geneva, having a maximum height of about 4,500 feet. The fauna and flora of Salève are both rich and interesting, and it is much to be regretted that during the last half-century they have been so inconsiderately collected, coupled with the approach of civilization, that many species formerly common have now become rare and in some instances have almost disappeared. This mountain is also of considerable interest to entomologists, as it is the northern limit for many southern species (May-June) This number contains a portrait of Dr. Jules Jullien, a late President of the Society. Mr. A. Milne-

Edwards and M. E. L. Bouvier contribute "Some Observations upon the Genus *Sympagurus*," the result of investigations made during the voyages of the "Princess Alice," which have done much towards extending the knowledge of this section of Crustacea. The article is accompanied by a tabular synopsis of characters. M. Charles Van Kompen writes on the "Variations of Colouration and the Hybrids of Mammals and Birds." M. Kempen says that while largely increasing his collection of mammals and birds during the last three years, he has been much struck by the remarkable varieties in colouration caused by hybridity and other anomalies.

BULLETIN DE LA SOCIÉTÉ PHILOMATHIQUE DE PARIS (Paris, 1895-1896).—The principal article in the last Annual Bulletin of this Society is by M. E. L. Bouvier, on "The Lobster Origin of Crabs," and "A Comparative Study of the Dromio Group of Crabs, Living and Fossil." The successful researches during the last twenty years, more particularly those of M. Boas, have now completely established the affinities and evolution of decapod crustacea. As regards the affinities and evolution of crabs, that is to say of the most important and most varied group of decapod crustacea, they are less well known. Though we are aware that the lobster-like and dromio-like sections of the Dromiaceae are the most primitive forms of the decapod crustacea, and that all others are developed either directly or indirectly from them, we do not yet know the origin of these primitive forms. M. Bouvier's article is divided into two parts: the first half has twenty-six well-drawn illustrations, and contains arguments on the morphology of the true dromios, proofs that the primitive dromios cannot be descended from Pagurides, Galatheides, Thalassinides, or Astaciens; lastly, evidence that the dromios are transformed from the Homariens. The conclusion he arrives at is that "the Homoliens are strictly connected with the other Dromiaceae, and that they form in this family a perfectly homogeneous tribe, of which one can follow the links from the most primitive forms, such as *Homola cuvieri* to the most modified, as *Latreillia elegans*." The second half of the article is devoted to a "Comparative Study of Living and Fossil Dromiaceae." It contains seventeen illustrations. After a careful study of some of the various forms of fossil Dromiaceae and a comparison of their members with those of living species, M. Bouvier devotes two or three pages to the "Links in the chain of Living and Fossil Representatives of the Family Dromiaceae." He then proceeds to a consideration of them, anatomically and in embryo; concluding with an explanation of the figures inserted in the text. This is a very important article, evidently the result of much patient research. It occupies 110 pages, being illustrated as we have indicated above, by forty-three beautiful figures. Another article of value is by M. Charles Brongniart, entitled: "A Revision of the Salomonitae," a tribe of Locustidae, accompanied by a chart of the geographical distribution of these insects, which appears to extend from Madagascar throughout the Australasian archipelago. There are also illustrations in the text indicating new or obscure species. This article occupies nearly 200 pages. M. Jules Mabille contributes "Observations on the Genus *Bulla*." He follows Klein's genus *Bulla*, which he points out was created in 1753, because he considers it a natural association of certain well-defined forms of Mollusca with which has latterly been associated other species of less definite generic character.

## SCIENCE IN SOME MAGAZINES.

APPLETON'S POPULAR SCIENCE MONTHLY (New York: July, 1897. 50 cents.) Professor William Z. Ripley continues a series of articles on "Racial Geography in Europe." In this number he deals with France and its occupation by the Teuton and Celt. He illustrates his views by photographs of modern types. Dr. R. W. Shufeldt has a popular illustrated article on "Some facts about Wasps and Bees." A beautifully illustrated article on "The Wild Flowers of the Californian Alps" is a charming feature of this number; it is by Miss B. F. Herrick. Other articles are on "The Planet Saturn," by Clifford A. Howes; "The History of Alcohol," with curious illustrations, by Professor C. E. Pellew; "Are Scorpions Matricides or Suicides?" by Dr. J. Velaró; and an obituary notice of the late Horatio Hale, the celebrated ethnologist, with portrait.

THE NINETEENTH CENTURY (London: July, 1897. 2s. 6d.) The article on "Recent Science" by Prince Kropotkin is divided into three subjects, viz: "Brain Structure," "The Approach of the Black Death," and "Snake Bite." Mr. Haverlock Ellis writes on "Genius and Stature" otherwise the anthropometry of genius. The author bases his considerations on the work of the Anthropometrical Committee of the British Association, which fixes the present average male Briton at 67.66 inches, while the most frequent height is 5 ft. 7 to 8 inches, the professional and commercial classes being a couple or more inches over this; and the labouring classes about the same measurement below the mean. The tables of tallness of celebrated persons included in the article are most interesting, for we find Darwin, Fielding, Abraham Lincoln, Sir Walter Raleigh, Thackeray and George Washington all among the taller men and over six feet in stature. Genius evidently, as some people have averred is not confined to small men. Still among the latter are Balzac, John Hunter, Keats, Napoleon, Nelson, and hosts of others who were only about or under five feet tall. A suggestive contribution to this number is by Lady Priestly on "The French and English Treatment of Research." A pleasing incident mentioned, is an account of Lady Priestley's visit to Madam Pasteur, who still occupies the residence connected with the Institute bearing her late husband's name, as neither M. Duclaux, the new director, nor his assistant-in-charge, M. Roux, will permit her to leave the home sacred to her with associated memories of her husband. The author's review is not favourable to this country, at least as regards the important branch of science practically inaugurated by Pasteur.

LONGMAN'S MAGAZINE (London: July, 1897. 6d.) "Bacteriology in the Queen's Reign," by Mrs. Percy Frankland, is a eulogy of the work done in the development and investigation of this comparatively new science, especially with regard to water examination and its purer supply.

THE STRAND MAGAZINE (July, 1897. 6d.) This month natural history, as latterly usual, takes a prominent place in this magazine. A new series commences, entitled "Glimpses of Nature"; the first being by Mr. Grant Allen on "The Cows that Ants Milk," a popular article on the well-known association of ants and aphides. The illustrations are simply charming, and, need we say, accurate, when we mention Mr. Fred Enock as the artist.



THE SOUTH LONDON ENTOMOLOGICAL AND NATURAL HISTORY SOCIETY, May 27th, 1897, Mr. R. Adkin, F.E.S., President, in the chair. Mr. Bainbridge Prest, M.A., of Sydenham, was elected a member. Mr. South exhibited a box of *Tephrosia*, which he had purposely mixed as regards dates and localities. He asked for information as to names, but no one essayed to pick out the two forms. Mr. Auld, larvae of *Boarmia roboraria* and *Limenitis sibylla* from the New Forest, and also larvae of *Phorodesma bajularia* and *P. smaragdaria*, and remarked on the close similarity of the former in its covering of oak remnants to the groups of brown scales enclosing the buds on the oak twigs. Mr. Moore, male and female specimens of the remarkable Mexican Pierid (*Pyristitia proterbia*), a bright and rich orange-coloured insect. Mr. Tutt, specimens of *Ascalaphus coccjades*, a neuropterous insect allied to the ant lion, from Digne, France, with notes on its history, variation and occurrence. It was described by Scopoli as a butterfly. Mr. Edwards, a living mantis, sent from Cannes by Dr. Chapman. He had had it some six weeks, and it fed readily upon small cockroaches and flies. He also showed young larvae of *Saturnia pavonia* from ova laid by a female taken at Digne. Mr. Adkin, series of *Cidaria suffumata*, from various localities, including Forres, Dover, Box Hill, and Loch Lagan. Those from the latter locality were var. *piccata*. Mr. Lindley, specimens of the resinous nodules of pine, sent him from Scotland, from which he had bred *Retinia resinella*. He also showed sections of the same and made remarks upon the peculiarities of the cocoon and the methods of emergence of the species. Dr. Chapman exhibited among other insects a living specimen of *Charaxes jasius*, which had just emerged from the pupa of a larva taken at Cannes. Mr. Step communicated a short paper, entitled, "Note on a variety of *Portunus marmoreus*," a crab taken at Portsatho, and sent for exhibition coloured drawings of the same. Mr. Tutt read a paper, entitled, "Spring Butterflies on the Riviera," and exhibited a large number of species in illustration.—June 24th, Mr. R. Adkin, F.E.S., President, in the chair. Mr. W. H. Drury, F.R.H.S., Kingston-on-Thames, and Mr. J. Sandison, Wimbledon, were elected members. Mr. Waters exhibited a long series of the eggs of the guillemot, showing the extreme variation to which the colour-markings extend. Mr. South, the series of *Zygaena filipendulae*, taken in Middlesex, and referred to at length in the "Entomologist," July, 1897. He was unable to draw any fine distinction between var. *hippocrepidis* and the type, and remarked that it was necessary that considerable attention should be paid to the genus *Zygaena*, before any certainty could be expressed as to the specific value of the various forms. Mr. Adkin, series of *Cyanins* (*Lycæna argiolus*), bred from ova and larvae taken last autumn at Eastbourne (Proc. S. Lond. Ent. Soc., 1896, p. 110), and contributed notes.—July 8th, Mr. R. Adkin, F.E.S., President, in the chair.

Mr. A. Perry, Anerley, was elected a member. Mr. Lucas exhibited nymph cases of *Anax formosus* taken by himself and Mr. W. Prest at the Black Pond, Esher, in June. Mr. Winkley exhibited a specimen of *Testacella haliotidea* from his own garden, which had existed there some considerable time, in spite of the gulls and teal he kept there. Mr. Auld, a fine bred series of *Phovodesma bajulavia* from the New Forest. Mr. Malcolm Burr, a small collection of Orthoptera from the Persian Gulf, collected by Mr. J. H. Hiles. They were chiefly European species (see "Entomologist," July, 1897). Mr. Ficklin, three specimens of *Dianthoecia luteago* var. *barrettii*, from Cornwall, this year. They were very different from the Irish form, being grey. This was interesting, as being the first well-authenticated occurrence of the species in England. Mr. Mera a bred series of *Hadena dissimilis* (*suasa*), from Essex, including a specimen having all the markings converted into longitudinal streaks. Mr. Turner, a bred series of *Cleora lichenaria* from Ashdown Forest, and series of several species of Coleoptera, including *Strangalia melanura* from Ranmore Common, *Ctenus scrophalariae* from Chalfont Road, and *Leptura livida* from Canvey Island. Mr. Robt. Adkin, series of *Eupithecia satyrata* var. *curzoni*, bred from Shetland larvae, and contributed notes.—*Hy. J. Turn. r., Hon. Report. Sec.*

NORTH LONDON NATURAL HISTORY SOCIETY.—On Saturday, May 15th, an excursion to Brentwood took place. The excursion was not very successful as far as collecting went, the previous very cold weather having retarded the emergence of most insects. Mr. Harvey found a nest with seven eggs of willow wren (*Sylvia trochilus*), and a nest with six eggs of redstart (*S. phoenicurus*). Very few lepidoptera were taken.—May 27th, 1897, Mr. C. Nicholson, F.E.S., President, in the chair at ordinary meeting. Exhibits: Mr. Battley, a large specimen of lichen found hanging from trees near Worthing. Mr. Bacot, pupae of *Epinephele hyperanthus*; larvae of *Acidalia inornata* and *A. marginipunctata*; a female *Eurymene dolobovaria* bred from an ovum laid by a female taken in the New Forest last Whitsuntide. Mr. R. W. Robins, *Pinguicula vulgaris* in flower; also growing plants of *Parnassia palustris*, *Viola palustris*, *Anagallis tenella*, *Campanula hederacea*, etc. Mr. C. Nicholson, bred series of *Anticlea badiata*. Mr. Wheeler read some "Dorsetshire Notes." Mr. Bacot enquired the reason for the decreasing population of the towns in Central Dorset. He said that the underground huts, mentioned by Mr. Wheeler in the course of his paper to have been found in the county, were still in use in some islands in the North-West Atlantic. Mr. Battley said that the chalk strata on the Old Harry Rocks on the side nearest Bournemouth were nearly horizontal, but as we approach Swanage they suddenly become nearly perpendicular, similar to the chalk at the Needles, I.W., of which this is a continuation. After the chalk, the various Wealden formations follow, also perpendicular, and the Purbeck beds are reached at Swanage. This peculiar position of the beds causes the great diversity of scenery around Swanage, as a large number of distinct formations crop up within a few miles. Messrs. Woodward, Simes, Austin, and C. Nicholson, also took part in the discussion. Mr. Wheeler, in the course of his reply, denied that Dorsetshire people were less energetic than those of other counties.—June 19th, 1897. Excursion to Cheshunt. A number of members and visitors arrived by train at 3.30, and at once made their way to the marshes

lying around the river Lea. It soon became evident that the recent cold days had prevented Lepidoptera from emerging, but flowers were very abundant. In the ditches *Hottonia palustris* (water-violet), *Thalictrum flavum* (meadow-rue), *Myosotis palustris* (forget-me-not) and *Valeriana officinalis* (valerian) were noted, whilst the fields were in many cases covered with *Rhinanthus crista-galli* (yellow-rattle). Working along the edge of a small stream, Miss Robinson noticed a larva of *Cucullia verbasci* on a plant of *Scrophularia aquatica* (figwort), and this species of larva proved afterwards to be well distributed. Among birds, the kestrel, corncrake, reed-bunting and sedge-warbler were the most noticeable. After tea the members proceeded to the other side of the river where flowers were even more abundant, *Nuphar luteum* (yellow water-lily) and *Mimulus luteus* (monkey-flower) being among those not previously noted. Lepidoptera were beginning to fly, including *Miana fasinucula*, *Hydrocampa nymphaeata*, *Cataglyphis lemuala*, and several species of Micro-Lepidoptera. To these flowers Miss Martin records a list of about thirty other plants, in addition to those already mentioned.—June 24th, 1897, the President in the chair. Exhibits: Mr. Prout, larvae of *Anticlea* (?) *badiata* and *A. nigrofasciaria* for comparison. He drew attention to the doubt as to the classificatory position of the former. Standinger places it in *Scotosia*, which seems no more appropriate than *Anticlea* (perhaps less so). Another position which has been assigned to it, namely in the genus *Ortholitha*, corresponding to *Eubolia*, seems worth looking into; Mr. C. Nicholson, larvae of *Cucullia verbasci*, from Cheshunt, and *Ephyra pendularia*, from eggs received from Mr. Bishop, who had obtained them from a moth taken at Oxshott; also a piece of *Mimulus luteus*, or monkey-plant, from Cheshunt. Mr. Prout had spent the last three days at Mildenhall, and had taken, at Tuddenham, *Agrophila trabecalis* in any numbers, a few *Acidalia rubiginata*, four female *Dianthoecia irregularis*, one fresh specimen of *Heliothis dipsacea*, a pair of *Lithosia griseata* and a couple of somewhat worn specimens of *Spilodes sticticalis*. Mr. L. J. Tremayne recorded nine *Setina irrorella* and two *Acidalia ornata*, neither of the species being in brilliant condition, from Boxhill, on Jubilee Day. Mr. Battley remarked on the similarity of the fauna and flora of Tuddenham to those of the sea-coast district.—June 26th. A field excursion to Oxshott, Surrey, was well attended. Among other species taken were *Hadena genistae*; *Eubolia plumbaria*, locally common on heath and in fine condition; *Lycaena aegon*, also fine; *Euthemonia russula*; *Dianthoecia car-pophaga*; *Ellofia prosoparia*; *Macaria liturata*; *Aspilates strigillaria*; and in the evening flight, *Angerona prunaria*, with occasional *Acidalia luteata*.—*Lawrence J. Tremayne, Hon. Sec.*

[After careful consideration we have decided not to publish a long report of a discussion on "Vivisection," which took place before the North London Society. This is chiefly because the meeting only represented one side of the question, and there was not anyone present to deal exhaustively with the other side. We fear this subject has become fettered by so much sentimental exaggeration that it can now only be satisfactorily argued by experts who are possessed of a knowledge of the facts on both sides.—Ed. S.-G.]

CITY OF LONDON ENTOMOLOGICAL AND NATURAL HISTORY SOCIETY. May 18th, 1897. Mr. J. W. Tutt, F.E.S., President, in the chair.

Exhibits: Dr. Chapman, *Heterogynis fenella*, a moth sometimes spoken of as half-way between a *Psyche* and a *Zygaena* from the delicate flimsy structure of the black male. He said: "Really, it is related to *Zygaena*, in so far that it appears to belong to the same stirps, but is far lower in the scale of evolution. The female is rotund like the larva, but is even less supplied with appendages, having no trace of wings, whilst the true legs are organically connected with the pupa-case, and retain it in its position outside the cocoon, enabling it to return to the interior of the chrysalis case, within which it lays its eggs." Mr. Bacot, larva of *Zygaena trifolii*, sent by Mr. Simes, from Cornwall; larvae of *Angerona prunaria*, also of *Tephrosia bistortata*, and *T. crepuscularia* for comparison; larvae of a cross between *bistortata* and *crepuscularia*. Mr. Bacot read notes on his exhibits. Mr. Bell, an owl's pellet from the stump of an old tree at Boxhill. One half he had dissected, the other remained in a solid state. The dissected portion showed small bones, teeth, fur, etc., of mice, the mounting of which was much admired. Messrs. Tutt, Heasler, Sauzé and Nicholson, also exhibited. Mr. Sauzé read a paper, entitled, "Industries and Politics of Ants." He said: "At the name 'ant,' there is, perhaps, conjured up in the mind an ideal insect, which leads to disappointment on watching an ordinary working ant out of doors, as a casual glance of a few ants is misleading. How the efforts of individuals, little in themselves, tell up in the aggregate can be seen by examining a common object in our woods, the nest *Formica rufa*. The marvel in ant-life is the multiplicity of resources, habits and industries occurring in the many species. Of the inhabitants of a nest, the males and females were spoken of with their natural duties, and the workers, major and minor, the former appearing to act as sentinels or 'soldiers,' the latter attending to the duties of feeding the grubs, carrying pupae into warmth, removing them from danger, and helping to force the imago from the pupal pellicle. It is these workers who build, forage, keep and distribute the common stores." Attention was next drawn to the connection between ants and aphides; to the migrating and hunting habits of species *Eciton* of South America; to the so-called slave-making habits of *Formica sanguinea* of this country, *F. fusca* being the ant enslaved; to the harvesting instincts of species, *Atta*, etc., in India, South France and Palestine; to the operations of the extraordinary agricultural ant of Texas, and of the umbrella ant found in tropical America. As regards intelligence, ants were thus seen by these varied practical developments to deserve a high place, and in the opinion of the reader to rank before bees and any other invertebrates. The nearest analogy amongst mankind of the mode of life and government in an ant's nest was thought to be a commune. All the inhabitants of a nest work harmoniously for the general good, the queens (though waited on) and the males (though cared for) seem to have no voice in the good government of the nest, which is, so far as known, an instinctive attitude of all, only possible in a community where in the case of the bulk of the race sexlessness prevents jealousies and weakness begets interdependence. Mr. Tremayne asked whether no instances were presented of ants performing their marvellous operations under distinct leaders. He thought such instances might easily be overlooked. With regard to the place which Mr. Sauzé assigned to ants among invertebrates, Mr. Tremayne suggested that

possible rivals to them might be found in termites, which were less known, but appeared to possess many of the socialistic abilities of the ants, and to be very similar to them in many of their habits. Messrs. Nicholson and Sequeira, with Dr. Chapman, continued the discussion. Mr. Dadd had known an ant carry away a full-grown larva of *Miselia oxyacanthae*. Mr. Sauzé said that ants on the march certainly have officers at their sides. He thought that, according to our present knowledge, ants were possessed of more intelligence and ideas than termites.—June 1, 1897. Mr. J. W. Tutt, F.E.S., President, in the chair. Exhibits: Mr. Heasler, *Tiresias serva*, bred from larvae obtained under bark at Richmond last January. This species appeared to pupate in the last larval skin. Mr. Bate, four female *Arctia caja*, the offspring of a pair exhibited with them, which were the second brood of 1896, which emerged in September. He said these four of their descendants, when Dr. Chapman's "forwards" fed through the winter indoors, pupated in February, 1897, and emerged after exactly fifty days in the pupa state. They were generally dark, and had more or less black fringe to hind wings. Mr. Bate also exhibited two larvae of *Saturnia pavonia-major*, one in second and one in third skin. The first was black, with orange tubercles; the second was green, with interesting club-shaped hairs on the thoracic and last two abdominal segments. Mr. Prout, a short bred series of *Melanippe montanata*, from a female captured in Epping Forest. Eight of these fed up and emerged in the autumn, two hibernated in their final skin. Also two bred specimens of the var. *shetlandica*, Weir, the larvae of which hibernated in the last skin but one; also a specimen of the var. *lapponica*, Stgr., from North Finland. Mr. Tutt, in his "British Moths," appears to unite these two varieties, but they seem to differ considerably (as Herr August Hoffmann has remarked), in that the former is darker and more ochreous, the latter much paler than the type form.—June 15th, 1897, Mr. J. A. Clark, M.P.S., F.E.S., Vice-President, in the chair. Exhibits: Mr. Nicholson, a specimen of *Boarmia consortaria*, taken in the New Forest on Whit Monday last, and some of the eggs laid by it. Mr. Tremayne, seaweed from Worthing. Mr. Bate, one male and five females of *Pieris brassicae*, bred from larvae, found last autumn. Two females showed slight deformation due to the tightness of the silk sling which the larva spun, which caused a deep indentation in the pupa. With reference to this exhibit, Mr. Nicholson said that he had always bred *Gonepteryx rhamni* with the mark of the pupa case across its wings, though not so badly as in these specimens. Mr. Bayne, varieties of *Coremia ferrugata*, *Melanippe galiata*, one with black solid band from Aylesbury, *Cidaria corylata* from Epping, one suffused with olive; *Vanessa urticaea* approaching var. *polaris* from Hoddesdon, 1897; *Nola cucullatella* with the melanic var.; *Thyatira batis*, one from Epping Forest without the pink colour in the spots, though very fresh. Mr. Bate had been at Oxshott on June 14th, and had found a few *Argynnis selene* and *Lycæna icarus*, and many *Adela degeevella*. He had also found a swarm of hive bees hanging to one of the lower boughs of a pine-tree; the bough being cut in half, the bees vanished, but they presently returned, and Mr. Bate succeeded in capturing them, bough and all. Mr. Clark said that *Hydrilla palustris* had again been taken at Wicken Fen on June 5th.—July 6th, 1897. Exhibits: Dr. Sequeira, two cocoons of

*Bombyx mori*, differing from the ordinary type, the silk being white; also a female specimen of *Acidalia alversata*, taken in his garden at Hackney. Mr. Woolley, living larvae of *Dicranura vinula*, in third and fourth skins. Mr. L. J. Tremayne, insects taken in the New Forest at Whitsuntide. Mr. E. M. Dadd, eggs of *Liparis salicis*, who said the eggs are laid in batches, a fresh one being made every day. The laying takes place during the hottest part of the day. They are bright green, and covered with a satiny silk. Mr. Heasler, beetles from the New Forest, including *Carabus nitens* and *Dasytes niger*. Mr. Clark recorded single specimens of *Dicycla oo* and *Cymatophora ocellaris*, from sugar, at Epping Forest. Mr. Tremayne had been at Oxshott on June 27th, when he found *Lycaena aegon* swarming all over the heath. Five *Macaria liturata* were taken, but practically nothing else worth noting, except, perhaps, a single specimen of *Ephinephle hyperanthes*. Mr. Prout had also been at Oxshott on July 5th, and had had much the same experience, but had taken rather more variety, his captures including *Eupisteria heparata*, *Melanippe unangulata*, *Erastria fasciana*, and *Nemophila russula*.—Lawrence J. Tremayne, Hon. Secretary.

**HULL SCIENTIFIC AND FIELD NATURALISTS' CLUB.**—The usual fortnightly meeting of this Club was held in the Friendly Societies' Hall, Hull, on Wednesday evening, June 23rd. The President, Dr. J. Hollingworth, occupied the chair. Mr. Waterfall gave an account of the club's excursion to Twigmoor Gully, and referred to the botanical rarities of that district. He also reported having seen the moonwort growing at York recently. The President exhibited some photographs taken on the excursion to Twigmoor, etc. For the Entomological Section, the Recorder, Mr. Boulton, stated he had obtained several additional larvae of the blood-vein moth from New Holland since our last meeting. He also gave an account of visits he had paid to Goole Moor and Kelsey Hill. A magnificent specimen of the marsh-cinquefoil, from the former place, and a live grass-snake, from Kelsey Hill, were placed upon the table. Mr. Phillip exhibited a large album of plants which he had collected from Northern Italy during the past few weeks. The plants were of a most beautiful description and were tastefully mounted. Mr. Porter handed round specimens of two moths obtained from Spring Head, viz., *Helodes arbuti* and *Hecatera serena*, which were considered good captures. Mr. Davis showed several large photographs of the natives of different parts of Africa, an interesting ethnological collection. The Secretary exhibited, on behalf of Mrs. Blenkin, of Burstwick, a pair of small deer-antlers which had been dug up near the Old Hall at that place. It is thought by antiquarians that this spot is the site of the castle of the Albemarles. This being so, the probability is that these antlers belonged to a deer which lived in the neighbourhood at the time the castle was in a flourishing condition. The Rev. A. E. Shaw, M.A., of Hull, and Mr. Wm. Wright, of Sutton, were elected members of the club. Mr. F. W. Fierke, M.C.S., then read an interesting paper on "Crabs." The first part of the lecture was devoted to a description of crabs generally, and also of other animals belonging to the same natural order, and an account was given of the various organs, etc., of these peculiar inhabitants of our coasts. This was followed by a description of the various species

of crabs to be found among the rocks at Filey, Flamboro' and other places within reach of Hull naturalists. Numerous specimens collected by the lecturer were handed round. The members were urged to pay a little more attention to the inhabitants of the rocks and pools on the coast, as much work is yet to be done in this direction. Several members took part in the discussion which followed the paper.—The first Meeting in the Club's new room, 72, Prospect Street, was held July 7th; Dr. J. Hollingworth, the President, occupied the chair. Mr. Blakeston handed round a magnificent specimen of coral, free from matrix, which had been lately found on the beach at Withernsea. This has, no doubt, originally been derived from the carboniferous limestone of Teesdale, and is probably a relic of the ice age. Two excellent examples of stone axe-heads were exhibited by Messrs. W. Chadwick and J. R. Boyle, F.S.A., which were described by the latter gentleman. Mr. Chadwick's specimen was about seven inches long and two inches broad, and was made of green jade, a fine-grained igneous rock. This specimen is of the chisel type, and is of a beautiful form with high polish. The other specimen has many points of interest; it is made of a tough grey stone, and was undoubtedly used as an axe. The cutting edge is well formed and polished, and, what is by no means a common feature, a large hole is drilled through the axe at the opposite end to the sharp edge, at right angles to it. Authorities vary as to the use of the hole, but Mr. Boyle was of opinion that it was drilled in order to securely fasten the head to a haft by means of thongs. This being so, it has an interest from the point of view of evolution, being, no doubt, the forerunner of the "ear" which occurs on some later bronze implements. Mr. Boyle's specimen is from Denmark. Other exhibits included some rare moths from the neighbourhood by Mr. J. W. Boulton, some geological specimens by Mr. Chadwick, and some large sponges from the south coast of Wales by the President. Messrs. J. Crompton, Wm. Anfield, Wm. Andrews and J. Walker were elected members of the club. A lecture was then delivered by the President, his subject being "Sea-Mats." It was pointed out that the plants and animals so frequent in our lanes, fields, woods and ponds, and also the common objects of the seashore are the first to attract the attention of the naturalist. The object of the lecture was to induce those members taking interest in no special subject, to undertake the systematic study of some particular branch of natural history. It is an impossibility to thoroughly master everything, and we are compelled, therefore, to devote our time to some definite subject. The President suggested that a most fascinating study would be the examination of the various forms of animal and plant life to be found on our shores, a subject not by any means exhausted. The lecturer then proceeded to give a brief and interesting account of the various species of sea-mats (erroneously called "sea-weeds") to be found around our coasts. He explained that sea-mats were really colonies of small animals, the cells being distinctly seen by the aid of a lens or microscope. After pointing out the various ways of identifying the different species, the methods of preparing and preserving sea-mats were dealt with, some valuable hints being given. Numerous specimens from localities on the east coast were handed round in illustration of the paper.—T. Sheppard, Hon. Sec., 78, Sherburn Street, Hull.

## NOTICES OF SOCIETIES.

## THE GEOLOGISTS' ASSOCIATION OF LONDON.

*Excursions and Conductors.*

Sept. 4.—Whitchurch, Oving, Quainton. A. M. Davies, F.G.S. Baker Street, 9.37 a.m. for Waddesdon Manor.

" 18—Holmesdale Valley. W. J. Lewis Abbott, F.G.S. Victoria (L. C. and D. R.), 1.30 p.m. for Otford.

For particulars of these excursions, apply to Horace W. Monckton, Esq., Secretary for Excursions, 10, King's Bench Walk, Temple, E.C.

## NORTH LONDON NATURAL HISTORY SOCIETY.

Aug. 2.—Whole-day Excursion to Shere. Leader, R. W. Robbins.

" 5.—"Reminiscences of Sugaring." L. B. Prout, F.E.S.

" 19.—Discussion: "The best place for a Naturalist's Holiday." Opened by C. B. Smith in favour of Barmouth.

Sept. 2.—"The Microscope." C. Nicholson, F.E.S.

" 4.—Half-day Excursion to Epping Forest. Leader, The President.

" 16.—"Explanatory Paper on the Order Hymenoptera." F. B. Jennings.

Oct. 7.—Pocket Box Exhibition and Microscopical Evening.

" 21.—Special Meeting to consider the New Rules.

" 30.—Visit to the Natural History Museum, South Kensington. Leader, S. Austin.

Nov. 4.—"Through Cornwall and Devon." J. A. Simes.

" 18.—Debate: "Does scientific study destroy or militate against the æsthetic tastes or sense?" Opened in the affirmative by F. W. Frost; opened in the negative by A. Bacot.

Dec. 2.—"Insectivorous Plants." R. W. Robbins.

" 16.—General Business Meeting—Election of Officers for 1898.

Meetings held at North-east London Institute, Hackney Downs Station, at 7.45 p.m.

There will also be a special-family discussion, entitled "The Liparidæ," to be opened by A. Bacot on some date not yet fixed.—*Lawrence J. Tremayne, Hon. Secretary.*

## WOOLWICH POLYTECHNIC NATURAL HISTORY SOCIETY.

*Meetings and Lecturers; Excursions and Conductors.*

Aug. 7.—Charlton Railway Station, 3 p.m. Charlton sand-pits—fossils and mollusca. F. Cornish.

" 12.—Woolwich Polytechnic. "Fish—their Structure and Habits." E. J. Cunningham.

" 14.—Plumstead Church, 3 p.m. Crossness—entomology. D. Millar. (For juvenile members.)

" 21.—Abbey Wood Railway Station, 3 p.m. Knee Hill and lanes—mollusca and pond life. W. Turner.

" 26.—Woolwich Polytechnic. "Setting and mounting Coleoptera." G. Cornish.

" 28.—Plumstead Church, 3 p.m. Ditch work in Manorway. H. J. Sargent.

Sept. 4.—Abbey Wood Railway Station, 3 p.m. Knee Hill and lanes—larvæ and mollusca. H. J. Webb.

" 9.—Woolwich Polytechnic. Exhibition by Microscopical Members. W. Scott.

" 11.—Plumstead Railway Station, 2 p.m. Greenbithe—mollusca, etc. E. J. Cunningham.

Sept. 18.—Plumstead Church, 3 p.m. Manorway—mollusca, ditch work, etc. J. E. Stacey. (For juvenile members.)

" 23.—Woolwich Polytechnic. "The Moon," illustrated by lantern views. T. W. Brown.

" 25.—Wickham Lane (north), 3 p.m. Bostal caves—*H. pulchella*, *C. rolphii* and *C. acicula*. T. W. Brown.

Meetings, alternate Thursdays, at Polytechnic, William Street, Woolwich, 7.30 p.m.—*H. J. Webb, Hon. Sec., Polytechnic; or 3, Gunning Street, Plumstead.*

## NOTTINGHAM NATURAL SCIENCE RAMBLING CLUB.

*Geological Section.*—Leader, Mr. J. Shipman, F.G.S.

Aug. 28.—Annual Excursion. Lincoln. Fare (special train), 1s. 6d.

Sept. 11.—Hucknall Torkard and Long Hills. Meet Midland Station, 1.30 p. m.

*Botanical Section.*—Leader, Mr. W. Stafford.

Aug. 14.—Nottingham Arboretum. Meet Waverley Street Entrance, 2.30 p.m.

Sept. 18.—Radcliffe and environs. Meet G.N.R. Station, 1.45 p.m.

Oct. 16.—Annual Meeting, Rambling Club, Natural Science Laboratory, University College, Nottingham, 4 p.m. Tea, soîrée and exhibition of collections made during season. *W. Bickerton, Hon. Sec., 187, Noel Street, Nottingham.*

## HULL SCIENTIFIC AND FIELD NATURALISTS' CLUB.

Aug. 2.—Y.N.U. Excursion to Everingham Park.

" 4.—Exhibition of local objects of antiquarian interest; members; 8 p.m.

" 7.—Kelsey Hill; leave Hull 1.58 p.m. Return fare to Ryehill, 1s. 7d.; from Southcoates, 1s. 2d.

" 14.—Day Excursion to Spurn.

" 18.—"The Colours and Odours of Plants," illustrated; Mr. H. Knight; 8 p.m.

" 21.—Carey Chalk Pits; leave Cannon Street Station 1.25 p.m. Single fare to Willerby, 4s. 4d.

" 28.—Dunswell Lane; meet at tram terminus, Newland, 3 p.m.

Sept. 1.—Microscopical Evening; members; 8 p.m.

" 4.—Leconfield; leave Paragon Station 1.10 p.m., train for Arram. Single fare, 1s., return from Beverley.

" 11.—Hessle; leave Hull 2.25 p.m. train. Single fare, 5d.; walk back *viâ* Humber Bank and Newington.

" 15.—"Diatoms." Mr. R. H. Phillip.

" 18.—Cleethorpes, for Clew; leave Hull 1.45 p.m., boat. Return fare, 1s.

" 25.—Endyke Lane; meet at Newland, 3 p.m.

" 29.—Annual Meeting.

*T. Sheppard, Hon. Sec., 72, Prospect Street, Hull.*

## NOTICES TO CORRESPONDENTS.

TO CORRESPONDENTS AND EXCHANGERS.—SCIENCE-GOSSIP is published on the 25th of each month. All notes or other communications should reach us not later than the 18th of the month for insertion in the following number. No communications can be inserted or noticed without full name and address of writer. Notices of changes of address admitted free.

NOTICE.—Contributors are requested to strictly observe the following rules. All contributions must be *clearly* written on one side of the paper only. Words intended to be printed in *italics* should be marked under with a single line. Generic names must be given in full, excepting where used immediately before. Capitals may only be used for generic, and not specific names. Scientific names and names of places to be written in round hand.

THE Editor is not responsible for unused MSS., neither can he undertake to return them, unless accompanied with stamps for return postage.

SUBSCRIPTIONS.—Subscriptions to SCIENCE-GOSSIP, at the rate of 6s. 6d. for twelve months (including postage), should be remitted to the Proprietors, 86, St. Martin's Lane, London, W.C.

THE Editor will be pleased to answer questions and name specimens through the Correspondence column of the magazine. Specimens, in good condition, of not more than three species to be sent at one time, *carriage paid*. Duplicates only to be sent, which will not be returned. The specimens must have identifying numbers attached, together with locality, date and particulars of capture.

ALL editorial communications, books or instruments for review, specimens for identification, etc., to be addressed to JOHN T. CARRINGTON, 1, Northumberland Avenue, London, W.C.

## CORRESPONDENCE.

J. C. S. (London).—We believe it is caused by throwing overboard from steamers red-hot "clinkers" from the engine-furnaces. The contact with the cold water causes the cellular structure. The rounded form is the result of the pieces being water-worn by tidal action on the shore.

W. B. H. (Hythe).—The larger shells are the var. *lutescens* of *Helix virgata*, and the smaller are young specimens of *Helix rotundata*.

## EXCHANGES.

NOTICE.—Exchanges extending to thirty words (including name and address) admitted free, but additional words must be prepaid at the rate of threepence for every seven words or less.

FRENCH minerals and shells offered in exchange for English.—M. Philéas Rousseau, La Mazurie, Par Aizenay, Vendée, France.

BIRDS' EGGS.—Buffon's skua, cuckoo, gulls, pea-hen, etc.; good variety. Wanted, good camera. Full list sent on application.—C. W. Bowell, Junr., Conway House, Allendale Road, Leicester.

WANTED, petrological and histological slides, books on microscopy, petrology and geology, and a good stand condenser. Offered, Foraminifera, mounted and unmounted; Maltese landshells, named by Italian specialists; and "Proceedings of the Linnean Society (Botanical)."—J. Cooke, Thorndale, Lincoln.

EGGS.—Clutches of merlin, kestrel, lesser redpole, Lapland bunting, grasshopper warbler, pied flycatcher and curlew for exchange.—Robert W. Ellison, 210, Hugh Gardens, Newcastle-on-Tyne.

## REPAIRING AN ELECTRIC CABLE.

BY A. H. BÉCHERVAISE.

FORTY years have elapsed since the first submarine cable was successfully laid between Ireland and Newfoundland by the steamship "Great Eastern," an event which excited general public interest at the time. Since then, cable laying and repairing has become such an every-day and matter-of-fact occurrence that it is rarely thought of by those not personally connected with this important and interesting scientific industry. To them, however, it has great fascinations, and an account of a recent repair of a submarine cable in these islands may be not without interest to your readers.

unknown resistance. In the old days it was very difficult to ascertain and allow for this resistance, and it is due principally to Mr. A. E. Kennelly that this difficulty has now been overcome. He, finding that a natural law governed the action of different *strengths* of current passing through the unknown resistance, formulated a method by which it could be accurately ascertained and eliminated. This method is to-day generally adopted in cable testing so successfully that it is possible sometimes to locate a break to within a few yards.

The cable between the islands of Teneriffe and La Palma being broken, and tests from shore

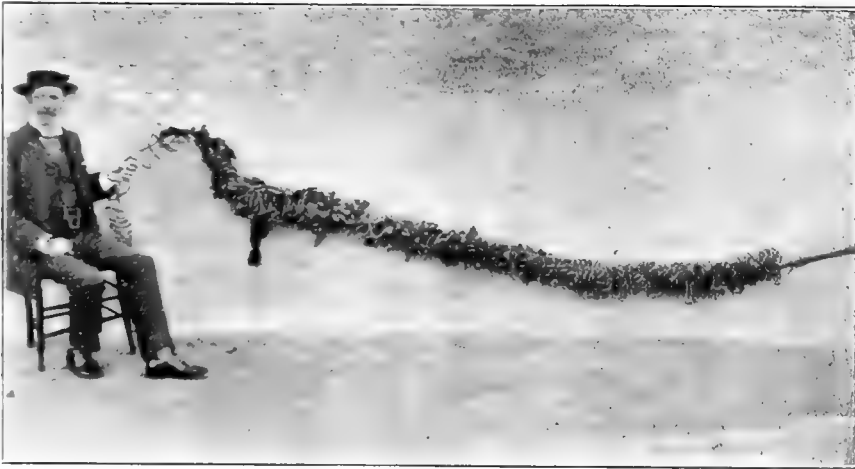

BROKEN MARINE TELEGRAPH CABLE.

The question is frequently asked, "How do you find out where the cable is broken?" When the break is a clean one, roughly, in theory this appears to be a simple matter, as the resistance offered by the copper core of the cable to a known battery power is most accurately ascertained, both before and after the cable is submerged. A cable which offers, say, a resistance of 10,000 ohms (the ohm is the unit of electrical measurement of resistance, in the same sense as the inch or foot is in the measurement of length) when perfect and 5,000 ohms when cleanly ruptured, may be presumed to be broken exactly in the middle of its length. This, however, is by no means always the case, as immediately the cable is broken and the copper conductor exposed to the sea, apart from the natural magnetic—or, as they are termed, *telluric*—currents which circulate through the cable, chloride salts form on the exposed copper and offer a very varying and

having satisfactorily located the position of break, the cable steamer was about to start for the repairing ground, and I was ordered to proceed to the Teneriffe end of the broken cable at the other side of the island. I left Santa Cruz in a large, roomy carriage, which, however, was so packed with the necessary apparatus, batteries, etc., as to allow little spare room for myself. After toiling up the steep road to a height of nearly 2,000 feet, we reached, and passed through at a gallop, the fine old city of Laguna. Leaving this behind, the real beauties of the island began to present themselves. The road was exceedingly pretty,—a continuous avenue of eucalyptus, oleanders, acacias, and cork trees, between which I got glimpses of the pretty landscape, dotted with orange trees laden with golden fruit, date-palms, and fields green with maize. With such pleasant surroundings the time quickly passed, and I reached my first stopping-place, La Matanza, or



"The Slaughter," so called because it was here that Bencomo, the ancient Guanche king, entrapped the invading Spanish army and annihilated it. Here, at the posting inn, I was welcomed by the portly landlady with proverbial heartiness, and sat down to a real Spanish dinner, very good, though rather garlicky.

After an hour's rest we inspanned, and started on the second stage of the journey. The grand valley of Orotava now opened up to view, and the famous peak, for once, at this time of day, was free from cloud. This is said to be one of the finest views in the world. The road descended now for a considerable distance, then rose to a height of about a thousand feet. We reached the Villa Orotava at nightfall. The day was the *fiesta* of San Isidro, the patron saint of the villa, and the town was *en fête*, being gaily decorated and illuminated. Amongst the many pretty decorations I noticed a triumphal arch wholly composed of agricultural implements, and these of the rudest and simplest sort. Iron-shod wooden ploughs, mattocks, wooden prongs, and so on,—all such as are used here even to-day in unscientific agriculture; which, however, thanks to the productiveness of the soil, is sufficient to support this comparatively thriving town. After a stroll through the streets I was glad to get back to the fonda, where I found an excellent bed, for which, in addition to early morning coffee, they charged me the modest sum of tenpence. At daylight the carriage came to the door, and I started immediately. Our first stopping-place was the picturesque and historic little town of San Juan de la Rambla, once the headquarters of the Canary wine trade, and from whence many a good pipe of sack formerly found its way to London coffee-houses. The wine made here is still good if drunk on the spot, but will not bear transport. After a short rest we again started and reached Ycod de los Vinos at 10 a.m. and here stayed for breakfast; then away down the newly-made *carretera* to Garachico.

Farther than this no wheeled vehicle may at present go, so I engaged a couple of camels for the rest of the road. These animals, after being loaded, arose with a grunt of dissatisfaction, and we started, myself on foot. Immediately after leaving Garachico we passed over the black lava stream which, during an eruption of the peak nearly two centuries ago, utterly destroyed the town of Garachico, and most of its inhabitants. It is strange to stand and watch it now,—black, silent, grim,—and to picture its cruel, relentless grandeur on that awful May morning of 1705.

We next reached the church of San Pedro, at the side of which, on a stone bench, are seated six skeletons, enclosed by iron railings, over the doorway of which is a quaint inscription in old Spanish, somewhat to this effect: "Wayfarer,

watch well, and take care what you do, for you will soon be as one of us." The skull of one had fallen off and was lying in his lap. This seemed to suggest the idea that he had done it for a joke, to enliven the otherwise rather solemn proceedings. The idea of this show was no doubt kindly meant by its author as likely to be a check on the waywardness of youth. Those six dead and bleached Canarios looked so hot in the blazing sun, and so altogether unbecoming, that although the priest, a pleasant-mannered man, told me he had some more inside the church if I cared to see them, I declined with thanks, and was quite glad to turn my back on the scene.

We now passed over the narrow road through fields of waving sugar-cane, and presently came to a large sugar factory at Daute, which is under the able management of Mr. Richard Tonge, an Englishman who, living alone in this out-of-the-way place, has done much to improve the agriculture of the island. He has, moreover, done yeoman's service to sugar planters generally by his observations of the habits of the moth-borer, *Chilo saccharalis*, the larva of which is such a very serious enemy to the cane, boring into the heart of it and destroying whole acres. Mr. Tonge has adopted a method by which this injurious insect is now practically eradicated on the estates here.

At four p.m. I reached the cable hut, a small corrugated iron house, seven feet by ten feet, fitted with a heavy testing table, the legs of which are imbedded in the earth, free from contact with the floor, so as to prevent vibration affecting the sensitive measuring instruments. I started at once to set up my instruments, which, to my great satisfaction, proved none the worse for the long journey. This operation took some hours, and I was glad, after a dinner of bread and tinned meat, to roll myself in my blanket, and turn in. I slept well in spite of numerous rats which I vaguely realized were sometimes running over me during the night. Next morning I turned out at four a.m., and lighted my mirror lamp, and commenced to watch for signals from the ship. This "spot watching," as it is humorously called by electricians, is slow work, and the day passed uneventfully. The only incident of interest was a dark object appearing in the surf, about a quarter of a mile away, and presently left high and dry on the beach. It turned out to be a dead camel. I immediately started my boy off with a sharp knife from the tool-box to cut off its hump, which was soon hanging to dry in the sun. A camel's hump in these islands is something Mr. Wemmick would include in the category of "portable property," and is worth from £2 10s. to £3, the fat from it being esteemed by the islanders as a certain remedy for rheumatism and other ailments. The day's watch being resultless, I ceased my



vigil at night and commenced it again early the following morning. The heat in this small iron house was intense, and about noon I was beginning to feel unpleasantly drowsy, when a slight kick of the mirror spot at once makes me extremely alert. That kick indicated to me that the ship's grapnel had hooked the cable. The instrument is so sensitive and my acquaintance with it so intimate, that I could follow by the light's movements the cable being raised and passed aboard and the end prepared and joined up to an instrument in the ship's testing-room. The ship then calls; a short test is taken, which, proving satisfactory, I am instructed to cease watch for a certain period. The end of the cable is then sealed and buoyed, the ship proceeding to grapple for the other end. This is later on picked up, tested to the other, and to me, distant shore. A new piece of cable is joined to and spliced on, and the ship pays out to the buoy on the Tenerife end. This buoyed end is then picked up, tested, and the final joint of the copper conductor and splice of the outer wires made, and the bight, or loop, thus formed is slipped and sinks to the bottom, where it finds a soft resting-place. Shortly afterwards an exhaustive test is taken, which proving to be satisfactory, the cable is handed over to the operators, and the beautiful Island of La Palma is once more on electrical speaking terms with the rest of the world. Nothing more remained for me to do but to pack up my instruments and start on the homeward journey, which I did with a pleasant feeling of satisfaction, engendered by the consciousness of duty done and the completion of successful work.

Since writing the above communication I have had the opportunity of taking a photograph of the broken piece of cable above referred to. I have pleasure in sending you a print, to show your readers the remarkable form these fractures frequently assume. The picture represents the injured section, which was cut out and brought in by the staff on the repairing ship, a few weeks ago, on the occasion when I conducted the tests described. Before the cable was picked up it was suspected the injury was caused by having become entangled with the anchor of some steamer or other, and this proved to be true. The photograph will show those interested how great must have been the extraordinary force exerted before the cable parted. The strong sheathing wires have doubled up, or "birdcaged," as we call it, before breaking one by one. This is an example of the contingents to which the working expenses of a cable company are subjected. It need hardly be added that such repairs are very expensive items, besides loss of revenue during breakage.

*Santa Cruz, Tenerife, August, 1897.*

## THE KENT COAL-FIELDS.

ON the 4th August last, we were invited to join a party formed to inspect the new colliery in course of construction near Dover. A special train from London had been arranged by the host of the day, Mr. W. J. Cousins, managing director of the contract company which is sinking the two shafts at the foot of Shakespeare Cliff and adjoining the closed entrance to the late Channel tunnel works. All this can be seen from the railway between Folkestone and Dover.

On arrival, luncheon having been served, the party proceeded to examine the works. These are now rapidly advancing, and consist of two shafts with the necessary engine and boiler power for winding and ventilating. We had the privilege of descending one of the shafts.

The history of this enterprise arose out of the closing by the Government, for political reasons, of the Channel tunnel works; which action, though most disappointing to the adventurers at the time, has proved to be probably one of the most fortunate events possible for the commercial prosperity of south-eastern England.

The present enterprise was commenced with the suggestion, by the Engineer, Mr. Francis Brady, that as all the material for a trial boring was on the premises, a search should be made for the coal which had, years ago, been forecast as being below that region by Messrs. R. A. C. Godwin-Austen and Professor Prestwich. The result of that trial boring, as our readers remember, was the finding of coal in considerable quantities at a depth of 1,136 feet, and again at intervals until 2,222 feet below high-water mark was reached. The boring was then stopped, but coal at greater depths is believed to exist. The Kent Coal Syndicate, which has undertaken to sink the shafts now in progress, have now reached a depth, in one of them, considerably more than half-way down to the first workable seams, so that it is expected the practical winning of coal for market purposes will have been attained by February next.

All the machinery and other appliances used by Mr. Cousin's company are of the newest and most advanced character. The pits are seventeen feet and twenty feet in diameter respectively. The work is being now conducted in the wider shaft, at the rate of some thirty to forty feet every week. This is very rapid progress when it is considered that only a limited number of men can work at one time, and that the sides of the pit have to be bricked round with solid and thick walls as the sinking proceeds.

From the geologist's aspect this work is of the highest interest, and we hope in an early number to be able to place some facts in connection with it before our readers — *John T. Carrington.*

## AERIAL TORPEDOES.

BY JOHN T. CARRINGTON.

ONE of the most remarkable applications of science in modern times is to aerial torpedoes by Mr. Hudson Maxim, the celebrated American chemist and inventor. This gentleman must not be confused with his brother, Mr. Hiram Maxim, who is at present engaged upon the solution of the problem of aerial navigation.

Mr. Hudson Maxim has published a book, which is beautifully illustrated and is otherwise a remarkable production<sup>(1)</sup>. So terrible indeed is the subject that one stands appalled before it. When we think that the mere pulling of a fuse-cord attached to a big gun will set in motion such devastating machinery created by man, we wonder where his inventive faculty will carry him in future ages. This sharp touch of the fuse-cord sets in flight a mass of explosive material enough to sink several immense men-of-war and destroy the thousands of strong men forming their crews.

The first paragraphs of the book, indeed, form an apology of the inventor for this awful creation of his brilliant mind. They run thus in part:

"War must be looked upon as a business, and subject, like any other business to business principles. War is the business of destruction of life and property of an enemy, and has no regard for the sacredness or pricelessness of human life. At best war is cruelty; but it is not only often a necessity, but unavoidable, and once engaged in should be made as terrible and destructive as possible while it lasts, in order that it may be brief as possible, thus minimising the evil in the aggregate. . . . The most deadly and destructive implements of war are the most humane, and the producers of them may justly be looked upon as humanitarians. Such inventions have put a limit to the time when barbarian hordes can overrun and subdue the earth; to ravage, destroy, and enslave by sheer brute force and power of numbers."

A short time ago we had the pleasure of spending an afternoon with the inventor, and of examining specimens of these torpedoes and other things of equal interest in his laboratory. Though surrounded by such death-dealing objects, they have by no means imparted to their inventor the savageness of destruction. We found Mr. Maxim the type of gentle kindness and bright humour. It is only within the last forty years that torpedoes were invented, and they have been hitherto submarine in their action. Mr. Maxim, however, has invented and successfully tried a more accurate system than that of the marine torpedoes, which

(1) "Maxim Aerial Torpedo: A New System of Throwing High Explosives from Ordnance, and some Recent Improvements in Smokeless Powders," by Hudson Maxim. Illustrated. (London: Eyre and Spottiswoode, 1897.) Price 21s.

are, whether active or passive, more or less uncertain in their action. In the old system there are no half measures, for either the object attacked is completely destroyed or it escapes it altogether. In the Maxim system it is not necessary to hit the enemy's ship with the active form of torpedo, for if one of his invention explodes within a considerable radius, even the most powerful war-ship afloat would collapse and immediately sink.

For some years past there has been going on a close contest between the artillerymen and the makers of armour-plates for defending ships. The present position of this contest has been latterly advanced in favour of the guns. This has been achieved, however, at immense expense and by sacrificing the possibility of quickly moving the guns from place to place, or of easily handling them. Great weight of metal constitutes their ability to withstand the strain of the enormously heavy charges of powder used. In this game of destruction and resistance, the tendency of the artillerymen has been in the direction of relying upon the smashing effect of a huge steel bolt. To succeed, this bolt must hit the object desired, and we know how uncertain is that hitting, as can be observed by watching gun practice at sea. It will be found that the hits are by far the exception.

The Maxim system is to substitute torpedoes for the shot and shell at present used in big guns. The inventor claims, among other advantages, that a torpedo projectile of twice the calibre, double the length, and three times the weight of the present armour-piercing shell, half of which may be high explosive, projected with a less velocity, is capable of working more destruction upon the average target than the present shell. A gun can be made at less cost than the present types, and of double the calibre, but of equal weight with the present forms of high-power guns, which will be capable of sustaining a working pressure of 10,000 lbs. to the square inch. A propelling charge of smokeless powder can be produced which with full charges will give an initial pressure of 10,000 lbs. to the square inch and maintain that pressure behind the projectile in its flight through the entire length of the gun. The torpedo projectile can be made capable of carrying its own weight of wet compressed guncotton or other suitable high explosive, such as picric acid or maximitite, and will be of such shape and strength as to enable it to sustain the mass of explosive in its flight from the gun, and endure with absolute certainty of perfect

safety the shock of acceleration exerted upon it when firing the gun.

To successfully throw these engines of destruction, a steadily increasing pressure in the gun is desirable. Therefore, in conjunction with Dr. Robert C. Schüpphus, Mr. Maxim has invented a new form of smokeless powder, which is cast into multi-perforated cylindrical forms. The object is that the ignition may proceed not only on the outer sides of these cylinders, but throughout the perforations which pass down the centre of each piece. This invention is so important that it has been adopted by the United States Government after prolonged trials at Sandy Hook.

The result of Mr. Maxim's invention of aerial torpedoes will probably be to the navies of the world similar to the discarding of metal armour by soldiers in olden times, when it was found no longer necessary or possible to keep out the projectiles fired by gunpowder. His torpedoes will render useless the most powerful armour-plates. We may expect after a time to see the energies of those charged with the care of our coasts devoted to the speed and mobility of vessels which can carry one or more guns from which these torpedoes can be thrown. Even now attention is being given to these small fast-steaming vessels in the form of torpedo-boat destroyers. Some have already attained a higher rate of speed than would have been thought possible only a few years ago. No one can forecast what may happen if boats of the new "Turbinia" type come into practical use. These are driven at very high speed by the power of steam turbines, instead of the ordinary screw-propeller.

Unarmed vessels carrying light, but powerful guns to fire aerial torpedoes, may shortly be seen afloat, with a speed reaching fifty nautical miles per hour. With one of these desperate little craft, a skilful and well-trained officer and crew may render useless a whole fleet of ponderous ironclads.

The aerial torpedo has an immense advantage over any torpedo launched into water and profling itself beneath the surface, because of the vastly greater range and accuracy of the Maxim torpedo, together with its comparative inexpensiveness and the far greater quantity of high explosive it will carry.

In Mr. Maxim's book, just issued, are full particulars of the aerial torpedoes, the details being explained at length, and illustrated by drawings. By these we find that the space occupied by the explosive in the old forms of torpedoes is extraordinarily small when compared with the Maxim invention. This, for instance, carries eleven times that of the Whitehead torpedo. The Maxim type will carry one ton of compressed gun-cotton with a range of five miles, whilst the

Whitehead type has a range of less than a mile, with only 200 lbs. of gun-cotton as the destructive explosive.

It will be readily understood that the exploding of such masses will carry devastation sufficient to blow in the whole side of a war-ship without ever touching the vessel. A man-of-war representing an area of 17,220 square feet would be utterly destroyed if a Maxim torpedo containing half-a-ton of gun-cotton fell and exploded within a circle of 245 feet from the centre of the ironclad. Likewise the same effect would occur if a Maxim torpedo with a charge of one ton of cotton exploded within a circle of 410 feet of the vessel. The pressure caused by such an explosion at that distance from the ship would drive in all the part beneath the water which is "below the belt" and forms the protection of the hull under water. If the torpedo were to pitch on deck or explode above the deck, the effect would be not only to sink the ship, but to kill every living thing on board of her.

Some readers will naturally think that great danger will ensue to those brave officers and men who man the guns which are to discharge torpedoes containing half-a-ton or a ton of gun-cotton. It has been found, however, that little danger exists when the cotton is compressed in a wet condition, for it cannot then be fired without a specially constructed fuse arranged for the purpose. In this state the mass may be tumbled about with impunity, and the torpedo may be shot through and through by an enemy without exploding, unless the small detonator happens to be struck. This occupies so small a place in the shell that little chance exists of a shot striking it. Thus, as the torpedo magazine on board the cruiser is placed well below the water-line, the chances of an explosion caused by the enemy's shot are very small.

When we consider that our large men-of-war carry each a population equal to quite a large village, we shall be reminded how awful will be the destruction of life in future naval warfare. Mr. Maxim's system, if generally used, will enormously add to that elimination of human existence. We believe, however, that such inventions are in the end for the good of mankind. When science is thus made the active agent in battle, instead of brute-force, the powers and governments must, under such circumstances, in time, hesitate to enter upon war. The human race will always produce men whose ambition carries them beyond the thought of sacrifice of their kind to attain their selfish ends. Aerial torpedoes and the like engines of destruction will, however, stop much of the ardour of their followers, for such applications of science reduce to a minimum the possibility of attaining distinction among the rank and file of the belligerent forces.

## DUST.

By J. O. SYMES, M.D.

THESE are many ways in which this subject might be treated, but steering clear of the philosophic side of the subject, it is my purpose here to treat of atmospheric dust, "the gay motes that people the sunbeams," "the dust of the dusty to-day, which is the earth of an earthy to-morrow."

Properly looked at, everything is dust. The original state of matter before the formation of the world was probably that of dust, and we may compare the process of transformation to that which to-day is taking place in the lesser stars. Such stars are cloud-like masses of particles travelling through space with such velocity and impinging against one another with such force as to become red-hot. Our stars, in short, are incandescent dust clouds, fated either to become molten masses cooling to new worlds, or to be absorbed into existing planets; or, failing either of these, to reach our or other worlds in the form of meteoric dust. Every day we are reminded that we ourselves are of the same material. In a couple of hours the process of cremation can convert the human body into about three pounds of fine ash.

Coming now to the dust of the atmosphere: there is no atmosphere free from dust. It is to be detected in the air of the highest mountains and in that taken from the most distant part of the widest ocean. It may vary in quality, it may vary in quantity, but it is universally present.

In an age in which savants have learned to count those vibrations of ether which give rise to light and sound, it is not to be marvelled at that they have also succeeded in numbering the motes in the sunbeam. Thus, it has been calculated that in the open country each cubic inch of air contains on an average two thousand dust particles, whilst in towns this figure is increased to three millions, and in inhabited rooms to thirty millions per cubic inch. As might be expected, the range of variation is very great; the higher the altitude the fewer the number of dust particles. The air of the country is freer than that of the city, and that of the streets less laden than that of inhabited rooms.

Mr. Aitkin, to whose work upon this subject we owe the greater part of our knowledge, records some remarkable results, dependent probably upon the direction of the wind and the presence or absence of rain. On a peculiarly still, clear day, a sample of air on the top of Ben Nevis contained only thirty-four dust particles per cubic inch; whilst under other conditions of wind and weather, air from the summit of the Rigi contained 10,000, and in the Simplon Pass 200,000 particles.

These few examples are sufficient to demonstrate how wide the variations may be. There is a fascination in the work of counting which threatens to make it a craze, like bicycling, and only last year an enthusiast made a voyage round the world armed with Aitkin's pocket dust-counter. This attempt to find an atmosphere free from dust was a fruitless one. He reached an altitude of over 13,000 feet, and it was there; and on the open sea, so far from land as to preclude the possibility of artificial pollution, dust could still be detected. Very curious are the phenomena connected with dust at sea. Off the west coast of Africa it frequently falls in dense clouds upon ships 500 to 1,000 miles from the coast. It may lie so thickly upon the water as to give it the colour and appearance of land, and the vessel's track may be marked in it for miles. Such an occurrence was noted by Darwin during his voyage in the "Beagle." The barren coral reefs of the Pacific Ocean receive their first layer of soil by similar means, and with the dust come those low forms of animal life whose part it is to crumble the rock into a soil, and fit it for the reception of air-borne seeds and spores, from which the island vegetation must spring. Dust is then a normal constituent of all atmospheres, and as such plays a very important part in the economy of nature.

Were there no dust there would be no mist, no fog, no clouds, no rain; for it is around these microscopical portions of matter that the condensation of aqueous vapour takes place. Each particle is enclosed in a covering of moisture, thus producing a haze, a fog, or a cloud, according as the dust is present in greater or smaller quantities. Without the presence of dust, the sudden cooling of an atmosphere saturated with moisture does not result in the formation of mist or rain. This is beautifully shown by allowing a jet of steam to issue into a chamber containing air, filtered through cotton-wool; the dense white cloud, such as we are accustomed to see over every engine-funnel, does not result. In fact, our smoke and "clouds of steam" are simply evidences of the presence of dust. In this way dust more than anything else determines the distinctness of our view of distant objects; the clearness or haziness of the landscape depending upon the number of particles in the atmosphere at the moment.

To a certain extent, however, the intensity of daylight, and indeed of artificial light, is dependent on the presence of dust. Without it there would be little or no scattering of light, as is proved by the fact that a ray of light passing through a

darkened glass chamber, free from dust, disappears, but returns again if dust be admitted. We say that a ray of sunlight breaking into a darkened room shows us the myriads of motes dancing in its beam, but the more correct statement would be that the motes show us the track of the sunlight. The character of our sunset and sunrise effects is determined by the same cause, the more dust the warmer and softer the light, so that to view these phenomena from mountain tops, where dust is scanty, is a mistake, at any rate as far as regards effects of colour.

Another great work in which dust is quietly engaged is the shifting of soil. We can see this on a small scale on every country walk. The fields bordering a great highway are constantly receiving a powdery layer, insignificant in itself, but sufficient in the course of years to materially raise the level of the surface and to bury objects lying on it. In countries where sand and dust storms are of common occurrence the process is much more speedy, a single storm sufficing to obliterate the landmarks of a whole country-side. It was held by many that the gorgeous sunsets seen in this country during the autumn of 1883 were occasioned by the dust following the eruption of the far-distant Mount Krakatoa. A similar dust-cloud buried the city of Pompeii in three days.

Passing to another part of the subject, consider for a moment the composition of dust. Speaking generally, it consists of animal and vegetable matter, and it is upon these two constituents that the myriads of germs which surround us flourish; consequently a dusty atmosphere means a germ-laden atmosphere. Dirt, on the other hand, affords a far less favourable breeding-ground for germs. It is too, to a great extent, fixed, so that although during a life-time one may have to swallow a peck of dirt, it is still more certain that one must breathe a ton of dust. On the whole it would seem better to be dirty than to be dusty.

Dust is the great carrier of micro-organisms, the two are inseparable. The number of microbes found in a given sample of air will vary according to the place from which it is taken. For instance, a cubic yard of air taken at the top of a Swiss mountain was found to contain, on the average, one germ; a similar quantity taken in the mid-Atlantic, six germs; in a city park, 450; in a city street, 4,000; and in a house, 10,000 germs. The dustiest spots yielding the highest numbers of organisms.

We live, then, in an atmosphere containing 200 microbes per foot, and thirty millions of dust particles per inch, and it is well to consider what evils we suffer as the natural consequence. The dust-laden air of mines and flour-mills will, if ignited, give rise to the most terrific and disastrous explosions. The excessive mortality amongst cut

lers, potters, and cotton workers is but the result of breathing air laden with fragments of the materials operated upon. These effects are now sufficiently obvious, and measures are taken to remedy them; but the evils arising from dusty streets and dusty houses are but little appreciated. With regard to our streets it cannot too strongly be emphasized that their efficient watering is a hygienic measure of the first importance. The mechanical irritation set up by breathing a dusty atmosphere may be sufficient to excite various lung diseases, whilst the accompanying germs may inoculate us with their several disorders. The fearful eye diseases so prevalent in Egypt and the East are consequent upon the clouds of filth that rise from the unwatered roadways, and the winter epidemic of pneumonia which visits Johannesburg is attributed to the same cause. The part played by dust in the formation of fog, mist and cloud has already been referred to, and it must be remembered that even when these are absent a pall of smoke hangs over our towns, so that we seldom or never get our due allowance of light and sunshine, which are as essential to our well-being as to that of every tree or flower. The dust from our chimneys and houses deposits on everything: it is an enemy to cleanliness, and it renders our climate cold and sunless. The most powerful of all germicides is sunshine; and by daily contributing, as we do, to the volume of smoke and dust, we are rendering our homes unhealthy and our lives less bright and cheerful.

Let it be remembered we ourselves are directly responsible for the condition of the atmosphere. Look for a moment at the conditions of town-life to-day. The streets, except indeed they be of wood or asphalt, are one day pools of mud and the next may produce clouds of dust. A goodly proportion of our fuel is scattered broadcast into the air in the form of smoke from factory or domestic chimneys. Every detail of our houses is either calculated to create dust or would seem to be especially constructed to retain it. Our floors are rows of chinks, choked with dust, held together by a few boards. Our ceilings are embellished with cornices—elaborate dust-traps only cleansed at the triennial whitewashing; fluffy wall-papers, carpets, curtains, each of the thousand and one bits of drapery with which we ornament our rooms, contribute their share to the general dust cloud. We are ever manufacturing dust-traps. The junction of walls with ceiling and floor are angles never to be explored. We nail down our carpets, so that even an annual beating becomes a labour. The very design of our furniture is a snare, so that few of us care to think of the dusty horrors that lie hidden in the flat, excavated tops of cabinets and book-cases. There are, of course,

the various functions known as "dusting," "doing out a room" and "the spring cleaning"; but these as a rule only aggravate the evil. The dust swept from the floor and furniture circulates freely in the air. What little may cling to the duster is, when the cloth is shaken at the window, swiftly blown into the room again. The housemaid at work is, as was recently stated in a medical paper, indeed a sight suggestive of many evils. "There she is on her knees, stirring up dust to her own destruction and the detriment of everyone else. Such dust as fails to find a resting-place in her lungs, dances gaily about to settle down again as soon as her work is completed." Some enlightened individuals, it is true, use damp cloths for dusting, and others seek salvation in tea-leaves or covered sweepers. At best, however, such luxuries are of trifling value.

What is needed is a reform in house decoration. Let our rooms be built with fewer angles and projecting surfaces, the corners rounded off, the floors rendered smooth, polished and impervious, and the ceilings and walls painted. Above all, let the amount of furniture be diminished,—a check put upon our enthusiasm for curtains,

carpets, pictures and drapery. Many other provisions will suggest themselves, such as the substitution of gas for coal, as a means of heating. These, one and all, will help materially to improve the character of the atmosphere that immediately surrounds us.

As regards clothing, too, a word is required. The rough, fluffy materials so much in vogue with both men and women keep up a brisk interchange of particles with the air. The amount of clothing fibre in dust is enormous, and probably only to be equalled by the quantity of dust in an ordinary garment. On hygienic grounds the use of napless fabrics, and of washing materials has much to recommend it, whilst to clothe ourselves in silk and satin is to confer a benefit upon the race. Happily, the days of long trains, and their accompanying clouds of dust, are gone. In some ways at least dress is becoming more rational, a change due no doubt in part to that dustiest of all recreations, bicycling. Many other points of interest in connection with the subject of dust, which want of space forbids me to touch upon, will no doubt suggest themselves to the reader.

## ARMATURE OF HELICOID LANDSHELLS.

By G. K. GUDE, F.Z.S.

(Continued from page 71.)

*PLECTOPYLIS polyptychia* (figs. 55a-d), from Mount Licos, Cebu, Philippine Islands, was described by Dr. von Möllendorff in the "Jahrbuch der Deutschen Malakozoologischen Gesellschaft," xiv. (1887), p. 272. The shell was figured in the same volume (t. 8, f. 8); the armature, however, was not figured, and I have pleasure in illustrating

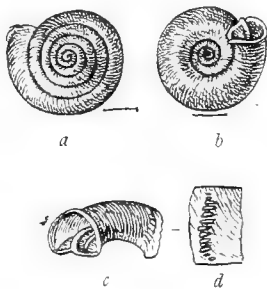

Fig. 55.—*Plectopylis polyptychia*.

which increase slowly and regularly, the last being angulated above the periphery and scarcely descending in front. The aperture is diagonal, oblique and heart-shaped; the peristome is but little thickened and reflexed, its margins are united by a raised bilobed ridge at the parietal callus. The parietal armature consists of two parallel, horizontal folds revolving over one-third of the body-whorl, the upper strong, and united to the raised ridge at the aperture, which it bisects; the lower thinner, not reaching quite so far at the aperture (see fig. 55c). The palatal armature consists of ten to twelve denticles, arranged vertically in a row, eight of which are larger than the rest, elongated horizontally, and have one or two minute ones both above and below them (see fig. 55d, which shows the inside of the outer wall with its denticles). The shell figured is in Mr. Ponsonby's collection, and measures—major diameter, 4 millimetres; minor diameter, 3.25 millimetres; altitude, 1.25 millimetres.

it. The shell is dextral, discoidal, openly umbilicated, finely and regularly ribbed above, finely striated below, and horny-brown in colour. The spire is scarcely raised and the suture is well impressed. There are five and a-half to six convex whorls,

*Plectopylis schistopytychia* (figs. 56a-e), from the Chinese province Hoo-Nan, was described and figured by Dr. von Möllendorff in the "Jahrbuch der Deutschen Malakozoologischen Gesellschaft," xiii. (1886), p. 185, t. 6, f. 2. As in the case of

the preceding species, the armature has not been illustrated, and I am glad to have an opportunity of giving figures of it. The shell is dextral, finely striated, and distantly ribbed above, finely striated and shining below, light corneous, pellucid, and widely umbilicated. The spire is a little elevated and the suture is distinctly impressed. There are from six to six and a-half convex whorls, which increase very slowly and regularly, the last being carinated above the periphery, rounded below, slowly and shortly descending in front. The aperture is roundly lunate, oblique; the peristome white, a little thickened and reflexed, its margins being connected by a much raised curved plate on the parietal wall,



Fig. 56.—*Plectopylis schistoptychia*.

slightly notched at the junctions above and below. The parietal armature consists of a strong vertical plate, having a short support posteriorly at the lower extremity, and two similar supports anteriorly, one above and one below (see fig. 56e, which shows the parietal wall with its fold). The palatal armature consists of eight small denticles (above which are a fold and a minute denticle) in two series of four each, the lowest denticle of both series being smaller than the others and nearer together. They are all more or less elongated, those of the posterior series being oblique, except the lowest, which is horizontal, while those of the anterior series are all horizontal; above these denticles occurs the fold just mentioned, which is thin, horizontal, interrupted slightly near its posterior extremity, and becoming attenuated anteriorly, while near its posterior extremity is found the minute denticle (see fig. 56d, which shows the inside of the outer wall with its fold and denticles). These structures are visible through the shell-wall. The specimen figured is in the collection of Professor Boettger, of Frankfurt, and measures—major diameter, 6.5 millimetres, minor diameter, 5.5 millimetres, altitude, 30 millimetres. A second specimen measures 6 millimetres in

diameter. Mr. Gredler, of Bozen, Austria, has obligingly sent to me for inspection two shells of this species which agree with the specimen here figured, except that one has ten instead of eight denticles, in two series of five each.

*Plectopylis biforis* (figs. 57a-f), from Ta-kouan-tchen, China, was described and figured by Mr. Heude in the second part of his "Notes sur les Mollusques Terrestres de la Vallée du Fleuve Bleu" (1885), p. 111, t. 30, f. 2. As I have been unable to obtain specimens of this shell, I have been obliged to rely upon Mr. Heude's description and to copy his figures. The shell is dextral, discoid, plicately striate, brownish, widely umbilicated. The spire is depressed and the apex a little raised. There are six and a-half slowly increasing whorls, which are flattened above and convex below, the last keeled at the periphery, with a lacinated fringe, and shortly and abruptly descending in front. The aperture is semi-circular and the peristome thickened and reflexed, its margins being connected by a raised flexuous ridge which is notched at the junction above and below; about the middle the ridge gives off an entering, flattened fold. The parietal armature consists of two vertical plates united above and below by horizontal folds; below these occurs a short, free, horizontal fold, while another short, horizontal fold is found anteriorly near the upper extremity of the vertical plate (see fig. 57d). The palatal armature is composed of four oblique folds, with a fifth smaller one close to the lower suture (see fig. 57e, which gives the anterior view of both armatures). From the figure it appears that there are besides, four small denticles posteriorly to the palatal folds; but no mention is made of these in

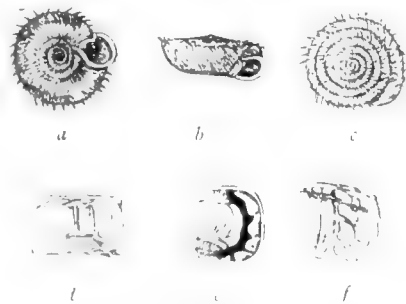

Fig. 57.—*Plectopylis biforis*.  
(After Heude.)

the diagnosis (see fig. 57f, which shows the palatal folds and denticles as they appear through the shell wall). The measurements given are as follows—major diameter, 16 millimetres, minor diameter, 14 millimetres; altitude, 7 millimetres.

(To be continued.)

## NOTES OF A HOME NATURALIST.

BY MRS. EMILY J. CLIMENSON.

ON the 1st of June I betook myself, with my family, to my old haunt, Bournemouth. Though civilization is more or less eliminating the rarer wild flowers from this place, yet still, in Little Durlay Chine, near where I am living, a careful observer may find many plants more or less uncommon. Owing, doubtless, to its position on a very steep declivity, therefore more or less inaccessible to ordinary folk, stand great groups of the milk-thistle, *Carduus marianum*. Its glaucous, milk-veined leaves, with their fearfully sharp prickles, are not easily gathered. It has been in flower for some three weeks, but the blooms are dying off now. It is a remarkably striking plant, and attains a height of at least four feet there. The blue gentian is still to be found, though not yet in bloom; the cotton-sedge, bog asphodel and sun-dew, though yearly diminishing, are there; also evening primrose, which is, of course, an escape. In the bog ponds, early in June, amongst other creatures, I captured some larvae of *Corethra* in which the air-sacs, generally black in those I find at Shiplake, were fully marked, but perfectly transparent. A *Corixa*, new to me, had an exceedingly rounded scutellum, marked with curious slanting lines all round it, the eyes bright red, the neck set on with a line resembling quicksilver.

On June 11th, at Swanage, I picked *Iris foetidissima*, *Orchis pyramidalis*, and saw the yellow-horned poppy in flower at the end of the bay under Ballard-down. The most gigantic horsetails, or *Equisetum telmateia*, grow in some of the small chines, or gullies, running down to the shore, presenting quite a tropical effect, with their strange foliage and rigid black-marked stems.

On the evening of July 1st, a member of the family rushed in about seven o'clock to say there was a swarm of hornets outside my window. Cautiously we peeped out; I saw thousands of creatures dancing around the window. Taking a butterfly-net, I made a swoop, and caught not hornets but cockchafers (*Melolanthus*). Being no longer afraid, we watched their gyrations calmly. Where they had all come from it was impossible to say; but it was a perfect eruption of exceedingly clean, bright young insects, who were pairing as fast as they could. I kept one pair for a day or two. For two nights after there were still a good many about, but not the swarms of the first night.

On July 2nd, I went a delightful excursion, by sea, to Lulworth Cove, but confined my energies to botanizing and sea-anemone hunting on the east side of the exquisite little bay. High up on the cliffs bloomed masses of the yellow-horned poppy,

wild fennel, samphire, great blue spikes of *Echium vulgare*, or viper's buglos, beds of pink rest harrow; below on the shore grew bushes or "tea" plant, escaped from some garden. At the eastern end of the bay lies the remains of a fossil forest, from which I procured specimens of fossil wood, and one specially interesting section of fossil palm-stalk. Amongst the seaweed-covered rocks were plenty of beadlet anemones, crimson and brown, together with one marked like a strawberry—red with yellow spots—and a peculiarly beautiful emerald-green anemone; all of which I brought home, and which are flourishing in shallow vessels.

On July 14th, a long, happy day was spent at Studland, an exquisitely situated little village placed in a bay that adjoins the entrance to Poole Harbour. Studland is about as good a place as an all-round naturalist could wish to stay in: scenery lovely; butterflies plentiful, as are also shells; a most varied flora, and at low tide a good assortment of sea creatures. Of specially interesting flowers, I picked, on the downs stretching towards Poole Harbour, *Inula conyza*, or ploughman's spikenard; *Erythraea centaurium*; *Sedum dasyphyllum*; and, bordering a little stream, in thick tufts were the exquisite pink and white flowers of the *Anagallis tenella*, or bog pimpernel. Amongst the rocks I obtained anemones, mussels, cockles, etc., and on turning back the seaweed in a pool, tried to catch by the tail a black snake-like looking fish, some ten inches long, but it snapped round so sharply that my courage failed and I ignominiously let it go. In another pool I caught a fish with the aid of a knife and a bunch of seaweed; it died on the way home. It was found to measure some six inches; was of a brownish-green colour, with nine spots on each side, at intervals, opposite each other; the spots were black, outlined with white; the tail ended in a circular fin, yellow, rayed with red; eyes were large and very close together. The only fish it at all resembled is the spotted gunnell, in "Marine Aquaria," by Mr. Bingham; but that in the picture seems spotted all over and has a back fin; this fish had no back fin, only one small one about half-way along the lower part of its body towards the tail. The sailors on board the "Empress" could not tell me what it was. The spots along the back gave it a very singular appearance.

Oldfield, Bournemouth; July 18th, 1897.

THE RATCLIFFE OBSERVER.—It is said that Dr. A. A. Rambant, the Astronomer Royal for Ireland, has been nominated to the vacant observership.



## CONTRIBUTIONS TO THE LIFE-HISTORIES OF PLANTS.

BY THOMAS MEEHAN.

*(Concluded from page 80.)*

## FLOWERS AND FLOWERING OF LAMIUM PURPUREUM.

ONE might suppose that a plant so widely spread over the world, and one that intrudes itself so persistently on everyone's attention, as *Lamium purpureum*, could not possibly have anything written about it that would be new to botanists. But I am inclined to believe that plants have not a uniform behaviour in every place, and possibly the behaviour of species here may be different from that in the Old World. These considerations make it the more important that the points I have noted in the plants growing on my grounds should be placed on record.

The species is very abundant as a weed on my grounds near Philadelphia. It is the form with the smallest flowers and without the ring of hair below the throat that is described in the typical form of Europe. It was originally introduced into my grounds from Germany. It is probably the form which Willdenow regards as a good species and describes as *Lamium incisum*. The hair that is found in the throat of *L. purpureum* is absent, there is but a single short tooth instead of two on the lower lip, and the pollen is orange instead of bright scarlet.

Dr. Bromfield notes "anthers with several tufts of stiff hairs or bristles on the face of each cell, and according to Mr. Leighton accompanied by six to eight small, white, oval, tuberculate bodies at their base, but of which I can find no trace in my specimens, and presume they are, therefore, not constantly present." These tubercles are only on one side of the anther and are easily overlooked. There are always six of these, so far as I have examined them; they are, however, easily overlooked as they are on one side only, as already noted. They are very beautiful as seen under a lens, but I have been unable so far to trace their morphological significance. A small gibbosity on the underside of the tube near the base seems to have been overlooked and may also throw some morphological light on the structure of the flower.

An interesting peculiarity is that soon after the ringent corolla opens it separates from the receptacle, the style disarticulating from the carpels at the same time and falling away with the corolla. In most monopetalous flowers, the pistil remains after the corolla fades, the corolla usually falling forward and over it. There is rarely any articulation by which the style separates from the carpels, as in this case, and as do the stamens in many flowers of other species.

This early fading of the flower and casting off of the pistil indicates that the flower may have been fertilized before the opening of the lobes of the corolla. An examination shows that this is really the case. When the flower is fully expanded the stamens are straight, bearing the anthers under the arched under lip. The anthers will usually be found destitute of pollen, while the longer lobe of the divided style will be found with an abundance of orange-coloured pollen at the apex. It will further be noted that from the relative position of the forks of the style and the anthers, the pollen could not readily reach this portion of the style while in the fully expanded condition of the flower.

If we take a matured flower-bud, just ready for expansion, and carefully cut away the upper lip, we find no stamens there at that stage. They, as well as the style, are bent downward, grasped and held in place by the incurved lower lip. Examining these unopened flowers in the early morning we find the anther cells have already opened and the sharp stigmatic point of the lobe of the style in most cases is inserted in one of the anther openings and covered with pollen. Between eight and nine o'clock in the morning the unopened buds unfold. Slowly the incurved stamens and style straighten themselves and rise to their final positions under the arched upper lip. During this process the stigmatic lobes are brought into contact with the disrupted pollen sacs, and receive an additional supply of fertilizing material, as if nature was taking a double care in this instance that the flower should be self-fertilized. The corolla at this stage seems firmly attached to the receptacle, but very soon afterward it falls at the slightest touch, indicating that fertilization has been perfectly accomplished. An examination of the flowers at this stage will also show that the seeds are wholly mature, and we have to conclude from this examination alone that the fertilization was accomplished in the unopened flower.

## SOME NEGLECTED STUDIES.

Botanical pleasures need not end with the first frost. Buds and branches furnish an endless variation, and are capable of affording characters quite as reliable as, and in many cases more reliable than, those offered us by leaves, flowers or fruit. For morphological or physiological study, a knowledge of the characters presented by buds and branches is invaluable.

A few days ago I came across a very thrifty pin oak about twenty-five years old. Along the

smooth, clean trunk, during the past season, a number of weak shoots had grown. I believe we cannot tell how an apical cell, which seems to be required before the growth of the branch can be started, can be formed out of an ordinary wood cell and be able to push its way through a layer of bark a quarter of a century old so as to produce the growth of twigs in question. There is an original field here for study as well as a theme for admiration. Perhaps my own discovery, published in the "Proceedings" of the Academy many years ago, on the nature of warts or excrescences on the trunks of trees, such as we very often see on the weeping willow, the garden cherry and other trees, may furnish an explanation. It is briefly this: new wood is formed by germination from original wood cells. These are added laterally during the growing season. The last series of cells born of the mother cells at the end of the season become liber cells, and give the new layer of bark for the coming season. But an occasional cell does not change. It continues to be a wood cell, though surrounded by others that have been transformed to bark. It does not separate from its woody matrix, but goes on forming its own additional wood cells, and in the autumn its layers of bark cells, in a sort of colony of its own. These are developed in every direction round the circular matrix, and the excrescence naturally forms a circle. An excrescence sawn asunder exhibits the annual growths of wood and the annual deposit of bark, just as the mother trunk does. I have never observed the excrescences make branches.

The manner in which buds are formed and protected at different stages of their growth affords endless pleasure. In *Liriodendron* the stipule encloses the younger growth, and, opening the bud, we find the leaf-blade has its apex fast in the axis between the branch and the petiole. No one can doubt that the truncate leaf results from its early casting in such a mould. In *Magnolia* we find the same protection from the stipule, but the petiole is not bent. The young leaves are folded longitudinally. We can see some of the processes by which nature makes *Liriodendron* differ from *Magnolia*, but what induces the curving of the petiole in one instance and the straightening in another we have yet to learn.

Though no reference is made of the fact in descriptive botany, the manner in which the base of the petiole folds over the young bud is distinctive of the genus *Rhus*, or at least of many species, for I have not examined all. The folding is so nearly complete that no axillary bud is visible. In the winter, after the leaves have fallen, we see by the cicatrices that it was a fold of the petiole and not an absolute over-growth. The cicatrix is precisely like that formed by the fallen leaf of the

horse-chestnut, and adds another suspicion to a list already by no means brief that there is a closer relation between the natural orders Sapindaceae and Anacardiaceae than systematists generally believe. Other species of trees, notably the plane and yellow wood, have similar embracing petioles. There seems no physiological advantage in these cases. The young bud must have some protection in infancy, and variety seems an essential part of the order of things. All we can say is that this form of protector is as good as any other. The internal arrangement of the bud in *Rhus* is interesting: two bud scales meet face to face, and closely press their edges together. The interior is a cavity, but densely filled with short, soft hair.

A Sapindaceous plant allied to the horse-chestnut, *Kolreuteria paniculata*, a small tree from Japan, has branches interesting from the fact that the petiole disarticulates at a little distance above the base of the petiole, leaving lacunose cicatrices, and giving the branch a singular knobby and rough appearance. Here again the teleologist will be at a loss, and seeing that it is no disadvantage, we can only say that it gives a pleasant variation to the run of life.

I might offer many illustrations, but enough has probably been said to show how much of interest the winter season may afford.

#### CHRISTMAS ISLAND.

ABOUT a couple of hundred miles south of the western end of Java there lies a small island about twelve miles long and seven miles broad, named Christmas Island. Although possessing a population of about a score of persons, one family being English, it had never been explored by any scientific person until quite recently. Dr. John Murray, of Edinburgh, proposed to the trustees of the British Museum to defray the expenses of such investigations, and very properly the trustees accepted the handsome offer. They selected for the purpose of conducting the exploration Mr. C. W. Andrews, of the Department of Geology in the Museum.

The area of the island is about 100 square miles, the land reaching an altitude of 1,200 feet. The fauna is very characteristic of its insular position, and has produced a number of species peculiar to the island. So far it has been found to be very rich in new species, including all the land birds, three new mammals, and over twenty of the insects, out of thirty-five species collected. In fact it is not often in these times that a scientifically trained collector and explorer has such splendid opportunity of so largely adding to knowledge in every department of biology and mineralogy.

## THROUGH THE MARSHES.

BY GEORGE BARHAM.

ONCE took Johnston, who is an editor of some kind of a magazine, on a ramble across the Graveney Marshes. We had talked natural history for some hours, and he was still dense. His idea of a snake was "a thing that crawled, and had to do with Adam and Eve." His knowledge of fish was limited to Billingsgate, and his staple birds were sparrows and wild geese. A sparrow he knew by sight; but a kittiwake or a sparrowhawk was always mistaken by him. He saw no striking difference between a skipper-butterfly and a clouded-yellow, whilst a meadow-brown was as invariably a moth as an oak-eggjar or a privet-hawk was a butterfly. He thought meadowsweet was yarrow. He was, however, a good editor.

We were proud of those marshes of ours; and though they are now well drained, and feed many sheep, yet in quiet corners the bulrushes grow, and the dykes are filled with delicate roach. The tide goes out for two or three miles, and leaves unctuous beds of ooze eminently suitable for curlews, and the common gull and the kittiwake go there for food. It was a magnificent morning, the faint white mist was slowly creeping away; the gleaming sails of the Whitstable Oyster Company's boats could be seen, and further out at sea they were dredging on the "Flats." Shellness, on the distant Isle of Sheppey, shone very white, also the Seasalter coastguards had freshly tarred their ornamental cannon-balls. In addition the grass was wet.

Whitstable, on the north-east Kent coast, six miles from Canterbury and "within easy reach of the great Metropolis," as the guide-book puts it, is an ideal place for the Science-Gossiper. The finest English exposure of the London clay is at Warden Point, a few miles away by boat. Swale-cliff and Hampton run it closely; Thanet sands, Oldhaven beds, alluvial deposits, and Romano-British remains are everywhere. The Romans fought the skin-clad warriors of Kent on the hill which now is Hampton Cliff, and sat down afterwards to meals of roast clams and horses' leg-bones. They lost at least one soldier of repute here, for I have seen his calcined bones in a cinerary urn. My father has that same urn by right of seniority, for he has an acquisitive disposition. Their commoner legionaries they buried in large-sized roofing tiles, and fished for oysters off the Stonehead. Popular report speaks of an Armada vessel wrecked off here, and its tomb is called the "Spaniard" to this day. Deep down at low tide are to be found whole jaws of the old wild bulls, and the no more gentle prehistoric horse. There

are other things, more gruesome, contributing their quota to the general interest.

Johnston gleefully started to gather puff-balls, and was interested in learning that they were not mushrooms. He listened patiently to my explanation of their fructifying surface, which lies concealed until by some means its outside envelope is ruptured and its spores dispersed. I pointed out to him that puff-balls are always to be found in fields where there are a number of clumsy-footed animals. Long years ago a solitary spore was carried by a persevering breeze into a field where there were cows. It grew and dried, and was broken by a providential hoof, and its family was established on a firm basis. That field then grew several puff-balls, and being fitted for their environment they colonized the neighbourhood, showing, in their humble, lowly way, an object-lesson to our French neighbours.

We lay down on the wet grass, under cover of a clump of sea-holly, and rested, waiting the while. Presently a heron came slowly within reach of our field-glasses. It halted by a dyke-side, paused there for a moment and then drew closer. "I know that—it's a crane," smiled Johnston. "Sh—!" I replied, laying a restraining arm upon him. They are very shy now, are the herons of the marshes, and but few in number, but this one was a truly fine bird. Fully adult, we could see, having the tall black crest and pendant breast feathers which mark maturity. *Ardea cinerea* is the learnedly scientific name that hides the beauty of the "hernshaw," "'ern" or "'eron," as our Marsh-folk call it. Whilst we were watching, an unsuspecting young water-vole essayed to swim across the sluice-dyke, on the bank of which the bird was waiting. The long bill darted down and the unfortunate rodent was pinched, and ducked, and pinched again, squealing the while in abject terror. Soon it was merely a shapeless mass of dripping fur. Then it was "pouched" and *cinerea* majestically flew away.

Marsh life will be seen to present features in common with other well-balanced and nicely regulated communities. By the Red-sluice, a tender shoot of grass springs up. An enterprising vole increases its family. In Ellendene wood a heron's egg is hatched. The young rat eats the grass, and the heron eats the rat. Perhaps, in the long, straggling town yonder, a man will take a gun and wind up the affairs of the heron. The mills of the gods, grinding in their proverbially slow and certain manner, will not miss that man.

"Wha-up! Cur! Hiew! Curlew!" A shrill

cry from the mudflats causes us to raise our heads. Yes, there is humour in our marshes. A man in a punt has been stalking a number of curlews which had been minding their own business by picking up little green crabs, smaller cockles, and innocent young shrimps. Their sentinel had seen the man miles away, and gone on feeding. Hopefully the man had drawn nearer, and still the birds had stayed. After a time, when another twenty yards would have brought the sportsman within range, the watching bird had slowly and sedately warned his brother waders, and the whole flock, uttering their piercing and unearthly shriek, had leisurely flown away. The curlews never trust to smell. Hearing they disregard as being deceptive, but seeing is strictly believing in their articles of faith. They are the most marvellous judges of distances in the bird world. I have known, where they breed, a sportsman who has frequently surprised the hen curlew with her young, when under cover of thick rushes. The situation then grows decidedly funny. The bird attempts to deceive the man. She seeks to convey the idea into his particularly dense brain, that she is a fine bird—very fine bird indeed; would be good eating, and a credit to his hunting. Also, that he has merely to stretch out his hand to pick her up. She tells him plainly that if he has one single grain of sense, he must see that she is injured—badly so. She cannot possibly fly, having hurt her wing, and cannot run, having unfortunately fractured her leg. In fact, he would do her a kindness if he would pick her up and put her out of her misery. If the man is like most men, he stoops to take her. The bird flutters five yards away and falls panting, so the man runs. She struggles a little further and apparently prepares to die. The man almost touches her, and she makes one more spasmodic effort. Sure of victory, he gleefully snatches at her, and she, uttering a loud laugh-like cry, joyfully flies away. The man goes to look for the young birds that he left in pursuit of maturer charms, and finds that the place where he saw them knows them no more.

Far away, on a distant ooze-bed, the mother curlew loudly tells the story to her admiring friends, and their shrill and concerted laughter-like cries, mingled with abominable insults and scathing sarcasms, cause the disappointment to enter more deeply into the man's soul.

The peculiarly penetrating nature of the vowel sound in the "curlew" cry causes it, like the Australian "coo-ee," to be heard for great distances. Curlews have been heard plainly when congregated on a bank of sand left bare at half-tide at least two and a-half miles from the observer; yet, when near at hand the call does not strike one as being particularly loud or shrill. It is the prettiest bird, to my mind, that we have in our marshes, and its

delicate, melting eyes, and the glorious browns of its wings defy description.

We have more than herons and curlews on those marshes; plovers are here in plenty, and now and then a stray godwit, also stint and occasionally whimbrel. Redshanks and greenshanks are here also; and once, before I knew Johnston, I saw two ruffs. Ruff and reeve, pretty and innocent looking birds are these, but they belie their appearance. Wait until the breeding season. They are fiercely pugnacious, and polygamous as well; consequently the males will fight savagely for the possession of a female that they will utterly discard the next hour; but there are no ruffs now in our marshes. There they have been shot at till others will come no more.

18, Chilwell Street, Nottingham.

## PLANTS OF KILLARNEY.

By JOHN H. BARBOUR.

IT was in this beautiful lake district that I spent four days' holiday this year; and now that I have returned I feel I cannot too much extol its charms. Here the geologist may be at home, or the man fond of folk-lore, and here also the botanist may ramble to his heart's content, amid the most luxuriant growth of flowers and fruits which nature ever produced in one district. Therefore, I give a short word-picture of the botany of Killarney. It is becoming for me to do so, to allure others to this most charming resort. Those who go there more especially interested in plant life, will find, if they wish, besides the woods and glens, in which is everything more nearly connected with their own pursuit, the most exquisite harmony of nature's majesty and power, blended with verdure and sweetness. Most beautiful are the Lakes of Killarney, though smaller than English lakes, which I know well, or some Scotch lochs. They are unequalled in that rich combination which aids in forming a Utopian spot, where we are loth to leave, and when we do, long to return again. Being August, I only take notice of a very few of the many plants I saw in flower that month.

Everywhere is the protusion of plants so great that it is well nigh impossible in four days to select one spot on which nature seems to have bestowed more care than another. Lord Kenmare's demesne and deer park, or Mr. Herbert's estate, are veritable nests of plant wonders, from fungi, through mosses which heavily clothe the trees like thick mats, to the traveller's joy (*Clematis vitalba*), twining its flowering stems everywhere and entangled with everything. The arbutus (*Arbutus unedo*) bark is light reddish in colour, and appears often twisted, as it were, round the trunk, and chipped. With its dull evergreen leaves and

strawberry-like berries, luscious to the taste, it covers the tops of many of the rocky grey isles of the lakes, and finds a habitat also round Muckross Abbey. As for ferns, the whole district in places is simply a mass of them. The royal fern (*Osmunda regalis*), some higher than a person five feet five inches tall, lines the margin of the lake at "The Meeting of the Waters," as the perversity of Irishmen call that lovely spot where really the waters separate, and elsewhere. Hart's-tongue (*Scolopendrium vulgare*) is very common; it may be seen on all the walls of Muckross Abbey and on Ross Castle, on all old bridges, and near the various cascades. At Muckross Abbey this fern forms, as it were, the floor inside and a basal fringe outside. There, in Killarney, also I saw maidenhair spleenwort (*Asplenium trichomanes*), hard fern (*Blechnum spicant*), brake (*Pteris aquilina*), polypody (*Polypodium vulgare*), scale fern (*Ceterach officinarum*), adder's tongue (*Ophioglossum vulgatum*), one or two varieties of *Lastræa*, and parsley fern, (*Allosorus crispa*).

White water-lilies (*Nymphaea alba*) float over "The Meeting of the Waters," and several varieties of crane's bill (*Geranium*), besides plants of herb robert (*Geranium robertianum*), may be seen everywhere one's eyes rest,—on old bridges, abbeys, or walls,—their bright-red leaves peeping out from among the moss and many creepers. Yellow-rattle (*Rhinanthus crista-galli*), enchanter's night-shade (*Circæa lutetiana*), and quite a herbarium of Compositæ are there, more especially of the division of Tubulifloræ, decking the fields and glades. The honeysuckle (*Lonicera periclymenum*) and ivy (*Hedera helix*) twist about each other over the tops of other trees. The rowan tree (*Prunus aucuparia*) is to be seen overhanging the pelucid water-edge, the red berries being there reflected. Innisfallen Island boasts well of its glorious trees. I saw on this isle hollies measuring nearly three feet round, and others perhaps more. They are there supposed to be the largest in Europe. Ivy stems with a girth of two feet or more, and many are the mazes formed as by the uniting of several trees into one. This is not really so, though appearing as if ash, holly, hawthorn and ivy were growing from one stock. Getting underneath them one can hardly distinguish whence the roots of each spring, or whither their branches trend.

Foxglove (*Digitalis purpurea*), known as "fairy bells," cuckoo-pint (*Arum maculatum*), and many Hypericineæ and Euphorbiaceæ are easily found during this month. In spring the blue-bells must flower well, since quite a carpet of their leaves betwixt some of the woods. Celandine (*Chelidonium majus*) I saw only once, but in moist, shady spots the two varieties of golden saxifrage (*Chryso-splenium alternifolium* and *S. oppositifolium*) were at different times noticed. The silver birch (*Betula alba*), oak

(*Quercus pedunculata*), spruce (*Abies excelsa*), larch (*Larix europæica*), pine (*Pinus sylvestris*), sycamore (*Acer pseudo-platanus*) clothe the mountains, whose conical peaks stand out so prominently, in many cases even to the very tops, as at the Eagle's Nest, etc. The yews (*Taxus buccata*) may be seen at Muckross Abbey and elsewhere, their red fruit somewhat brightening the dull, heavy, green foliage. *Erica* and *Calluna*, of course, are evident on the mountains; while *Sphagnum*, *Riccia*, *Marchantia*, *Lunularia*, and in one place *Fegatella*, I believe, are to be found in the bogland, or in sides of bridges and elsewhere. I met with no orchids, nor had I time to hunt for them. With the orders Juncaceæ, Graminaceæ and Cyperaceæ I had nothing to do, though by glancing casually at them now and again, I should imagine some interesting results might have been gained through their study. The willows, the laurels, the snowberry and the hazel are common everywhere.

At Killarney there is a splendid hunting-ground for the ardent botanist, but it requires time to be spared for research. Into the bargain he will have a holiday which will well repay a journey of any distance. There is much yet to be done in this country, well-worked up as it has been of late, without amateurs rushing off to continental resorts. I am convinced that wherever the botanist tourists go, they will be no more rewarded than if they visited Ireland, and gave Kerry and that most interesting district a chance. Not only will they find material for eye and mind, but also a most genial people to deal with. I would advise July, August or September as the best months of the year for going there.

One other matter I would like to draw attention to, and that is to throw out the suggestion, through the medium of SCIENCE-GOSSIP, that those who have the compiling of guide-books for the Lakes of Killarney should in future insert in them a list of plants whose habitat is more especially characteristic of Killarney. This is done in the case of some guide-books written about the English lakes; I have not yet seen such a list in any guide to Killarney. To the general public I believe it would be a boon, especially if some figures could be given. We want, for the general public, something a little more definite than mere names, something to stimulate their interest in the plants of the more well-known tourist districts. In conclusion, I have to apologise for so meagre a list of plants. My short stay, and being bicycling also most of the time, gave me less advantage for observing than if I had walked, as I could only stop at certain places to wander about for a while. I hope, however, this, my first visit, will not be my last, and that ere long I shall have an opportunity of again seeing "Killarney's lakes and dells."

Bangor, co. Down.

## VARIATIONS IN ERYTHRAEA.

By J. A. WHELDON.

HAVING resided for several years near the Lancashire sandhills, the metropolis of the genus *Erythraea*, so far as Great Britain is concerned, I have taken much pleasure in collecting

is described, no doubt our *E. centaurium*, but probably the author included all forms since defined.

The next work to which I have access, "A General System of Nature," by Sir Charles Linne,



ERYTHRAEA LITTORALIS, FRIES.



ERYTHRAEA LITTORALIS, VAR. INTERMEDIA.

a range of specimens to illustrate the wide variability of the species.

Perhaps no representatives of our flora have been more misunderstood in the past, and none more frequently wrongly labelled in the herbaria of collectors. Yet most of the species are old-established, and the characters which separate them easily demonstrated.

In "Wilson's Synopsis of British Plants, in Mr. Ray's Method," 1744, one pink-flowered centaury

edited by William Turton, M.D., describes two British species, under the names of *Chironia fulchella* and *C. centaurium*.

*E. latifolia*, probably the best defined but least understood of any of the species, was discovered in 1803 by Messrs. Bostock and Shepherd, and described as a varietal form by Smith in the "British Flora" (1804). It was given specific rank in 1824, in a later edition.

In Hooker's "British Flora," 1830, four forms

are doubtfully described as species. Of *E. fulchella*, the author remarks, "probably only a variety of the preceding" (*centaurium*); and of *E. littoralis*, "I fear it has little right to be kept distinct from *E. centaurium*." He admits that *E. latifolia* has more the appearance of a species than either of the two preceding, but says, "I can hardly persuade myself it is distinct from *E. centaurium*."

Withering, ten years later, in his "Systematic Arrangement," fifth edition, has four species, followed by a note to the effect that "the four alleged species above described are apparently varieties of the same specific form, dependent upon difference of soil and situation." This view is quite untenable by anyone who has seen them growing intermixed on the Lancashire coast, under identical circumstances of climate, soil and situation. They are accorded specific rank, without any doubtful note, in Babington's "Manual," sixth edition, 1867. The remaining forms mentioned in the "London Catalogue" do not occur, to my knowledge, on the Lancashire coast.

There can be little doubt that the *Chironia fulchella* of the older authors included *E. littoralis*, Fr., and though the technical characters are apparently of small importance, the general appearance of the two plants is so dissimilar that they are easily discriminated at a glance. *E. littoralis*, Fr., by which I understand a small, narrow-leaved plant, is very distinct when so restricted; but there is another form occurring on this coast which simulates *E. centaurium*. We appear to have two well-marked forms of the plant, easily recognised, but somewhat more difficult to define.

What I call *E. littoralis*, Fr., has narrow strap-shaped leaves, the margins of which are nearly parallel. The radical leaves are longly spatulate. The stem is seldom much branched, often simple, and the branches generally arise from the upper half of the stem. This is usually a small plant, and rarely exceeds four inches in height. It is the common form about Southport, both north and south of the town, and also occurs farther south, but more rarely, extending to the Cheshire coast.

The other form is occasionally a very robust and handsome plant, rivalling *E. centaurium* in stature and much surpassing it in the size and beauty of its flowers, which are of a singularly rich and deep pink, approaching magenta. It may be concisely described as a large form of *E. littoralis*, with the technical characters of that species as regards the relative length of corolla tube and calyx, but with broader leaves and the general habit of *E. centaurium*. The leaves are never strap-shaped, but oval lanceolate and occasionally ovate. They are only two to five times as long as broad, those of *E. littoralis* proper are from five to sixteen times longer than broad. The stem is branched from all parts down to the base.

This combination of the characters of two species which grow together, and the luxuriant growth and large size (for *littoralis*) of some of the specimens, led me to imagine at one time that they were hybrids. While still prepared to accept the view that there may have been cross-fertilization originally, I am convinced the supply is not kept up by this means, but that they ripen seed and reproduce their kind. The difference also is not due to station, as they grow together, and the different shaped leaves can be traced on small, starved specimens reduced to one or two flowers.

I have found the puberulent clothing of the upper part of the plant a reliable means of separating all forms of *E. littoralis* from *E. centaurium*. I have never seen this point noted in our handbooks. In *littoralis* the lobes of the calyx have a broader

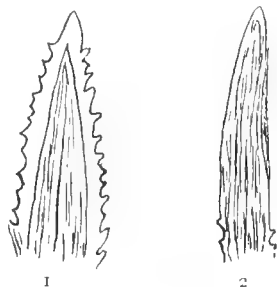

APEX OF SEPALS (much magnified).  
(1) *E. littoralis*; (2) *E. centaurium*.

hyaline margin than in *centaurium*, and this border is gland ciliated almost to the apex, giving it a serrate appearance. A few glands occur on *E. centaurium*, but they do not extend so far up the sepals. I would suggest that the name *E. littoralis* (Fries.) be restricted to the plants having narrow, strap-shaped leaves, and that those with broader and more oval leaves be named *E. littoralis* var. *intermedia*. A small form of *E. littoralis* with oval leaves, collected at Inver Bay, east Ross, by the Rev. E. S. Marshall, and labelled by him "var. *minor*, Hartm.," are similar to starved forms of var. *intermedia*, only differing in being much less puberulous, less so in fact than in any form of *littoralis* I have yet examined. Although the two forms I have attempted to separate are very difficult to define on paper, I feel convinced they are really distinct, and that further observation in the field will result in the discovery of some additional character by which they may be separated more readily.

Since writing the above, the Rev. S. Gasking has kindly pointed out to me that the puberulous clothing of *E. littoralis* is mentioned in the specific character of that plant in "English Botany"

60, Hornly Road, Walton, Liverpool.

## THE BOG FLOW IN KERRY.

WHEN news reached Dublin on December 28th last, to the effect that a bog had burst from its boundary at the head of the Ownacree Valley, near Killarney, the Royal Dublin Society appointed a Committee to investigate the fact. This Committee consisted of Prof. W. J. Sollas, Mr. R. Lloyd Praeger, Dr. A. F. Dixon and Mr. A. D. Delap. They devoted the second, third and fifth days of January, to the examination of the "burst," and the Society has received their report.

It appears from this report that a dry summer had been followed by a wet autumn, and on December 27th a heavy downpour of rain set in, with a south-easterly gale. It was about two a.m. the following day that the bog gave way, and flooded the valley below with a vast mass of peat mud. No one seems to have seen it, nor in fact to have been disturbed by any noise which may have accompanied the event, not even the eight poor people who were smothered in its course. So extensive was this stream of peat and water, that a portion of a bed which was in Donnelly's house when swept away with its inmates was found fourteen miles down the valley.

The flow continued in an intermittent manner for a day or two following the break, as fresh portions of the bog gave way, the ruptures sounding like the booming of distant guns. The bog occupied a site 750 feet above sea-level, forming the watershed, and draining into the Blackwater. It rested partly on coal-measures and partly on carboniferous limestone, separated from the coal-measures by a fault running through the very middle part of the bog, and adjacent to the site of the fracture.

The cottagers and other residents say the bog was a soft one; but they could at all times of the year walk across it. The Committee examined the flora of the remaining portion of the bog, but it did not indicate more wet than is usual to like sites, as *Andromeda* and cranberry (*Vaccinium*), though searched for, could not be found. The plants commonest in evidence were *Calluna* (ling), *Erica* (heather), *Narthecum* (bog-asphodel), *Scirpus* (clubrush) and *Molinia* (purple melic-grass). The usual mat of *Sphagnum* was there, with tufts of moss and reindeer-lichen. The stream of mud, as it subsided, left behind large numbers of roots and trunks of fir-trees, which, sticking up in all sorts of fantastic shapes, added to the melancholy desolation of the scene.

The phenomena of a collateral nature attending this bog-burst have been collected by the Committee, and are summed up as follows: (1) A dry summer was followed by wet weather, and heavy rain fell just before the outburst. (2) An earthquake which had its epicentre in Wales occurred

in December, and is said to have been felt in Miltown-Malbay and other places in Ireland. This preceded the rupture of the bog by five days. (3) The stream of the Carrundulkeen was continued as a "wet line," or line of drainage, into the bog. At the origin of this was a swamp. (4) The neck of the bog was cut through by a working face of peat, which thus crossed the line of drainage. (5) The centre of the collapsed portion of the bog stood, before the outburst, seven feet higher than the sides. (6) The bog was disrupted along the line of peat-cutting, and liberated a deluge of water charged with peat. The volume of the discharged material the Committee estimated at about 6,000,000 cubic yards. (7) As a consequence of this discharge the crust of the bog subsided, so that after a lapse of some days its centre had fallen thirty-five feet below its original level, forming a depression with a depth of twenty-eight feet.

The cause of the outburst was believed to be from the fact that the viscous fluid of the bog was contained in a resisting wall, the pressure of the fluid and the tension of the envelope being in equilibrium. Owing to an increase of pressure, or a decrease in the strength of the containing-wall, this equilibrium was destroyed and ruptured in its weakest part. The fluid peat, under a head of pressure, rushed down the inclined plane provided by the natural drainage of the country.

Reviewing the explanations of bog-bursts, the Committee rely chiefly on the theory of Klinge, the latest investigator of such phenomena, who propounds an entirely new theory, expressing views differing from those usually held as to the constitution of peat-bogs. He considers that mountain bogs are of two different classes. Those which have grown in uniform climate like that of the western coast of Europe, characterized by a continual increase in degree of decomposition from their surface downwards; and those which have arisen under the influence of severe changes of climate; the latter consisting of alternate layers more or less highly decomposed. The different layers have different saturation limits of water, and these limits once attained never alter. There is no vertical movement of water through such a bog. The Royal Dublin Society's Committee, above referred to, consider that the Irish bogs belong to the class in which decomposition of the vegetable matter increases from the surface downwards. The decomposed peat is heavier than the water, and tends to accumulate at the bottom. The upper crust, on which plants are found growing, is formed of particles lighter than water, which float to the top of the bog. Thus it is between the crust and the heavier portion that most fluid should occur. The Committee's report then examines and discusses reports of the Com-



missioners of Bogs; some of the surveyors for whom take the same views as Klinge.

This Royal Dublin Society's report on the catastrophe of December 28th last, also reviews similar bog-bursts in Ireland in former years. They mention further, flows that have occurred in Germany and the Falkland Islands. Altogether this report is most exhaustive, carefully prepared, and cleverly written. It is of much value in connection with the study of geology "in the making"; and one that will doubtless be long referred to as authoritative.

### NEW METHOD OF STUDYING NEURATION.

PROFESSOR Henry Skinner, of the Academy of Sciences of Philadelphia, contributes to the "Canadian Entomologist" for August last, an interesting article on studying neuration without removing the scales off the wings. He says, "The opprobrium cast on the lepidopterist has been that he did not study the anatomy of his specimen, but depended too much on maculation and colour. There has been much truth in the reproach, as there are few of us who would destroy a rare or unique specimen to examine the neuration. Fortunately the time has arrived when the neuration can be studied with the greatest ease and accuracy, and permanently recorded in a photograph, or, more strictly speaking, a radiograph. The anatomy of a living chrysalis may be studied without removing the cocoon, and also the internal anatomy of the thorax and abdomen can be fairly well seen, and in time the process may be improved for this work. With the aid of the Röntgen, or X, rays and the photographic plate, one could make a picture of the neuration of the beautiful, rare and curiously-shaped *Ornithoptera paradiseae*, and not disturb a scale on its superb wings. With the fluoroscope one could doubtless see all the neuration without even going to the trouble of making a picture. This is indeed a wonderful age, and in future no entomologist will have any excuse for not studying the neuration of the lepidoptera, as he cannot say that he must denude the wings of his specimens, bleach them, and mount in balsam, as of old, and then destroy them."

WICKEN FEN.—We understand that nearly the whole of Wicken Fen, in Cambridgeshire, has been purchased by an association of gentlemen who are interested in natural history, especially entomology. It will be remembered that we wrote, in September, 1895 (Vol. II., N. S., p. 169), an article recommending the acquisition by some public body of that characteristic bit of fenland, in view of the preservation of some disappearing native insects.

### ABNORMAL RAINBOW.

A CURIOUS rainbow occurred at Lowestoft on August 19th, at five p.m. The day had been, from eleven a.m. onward, very unsettled, thunder and rain occurring at intervals. The wind was blowing off the land from the westward, and the rainbow was displayed on a dense bank of clouds passing away to the eastward.

For accuracy I may say our point of view was 11, Wellington Esplanade, Kirkley, which is South Lowestoft, and the phenomenon was seen by my wife, eldest daughter, and myself, both with the naked eye and through a binocular field-glass. There was a faint, perfect, secondary bow, which presented normal features not shown in diagram. The bow marked *A* was perfect, and presented no

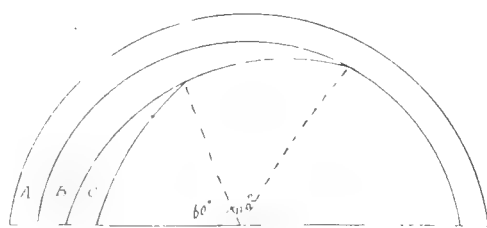

Towards Lowestoft Pier.

Towards Kirkley Cliff.

unusual features. The bow *B* was a half-crescent-shaped segment extending about  $120^\circ$ , and exhibiting the colours of the spectrum from violet to yellow. The segment *C* extended about  $60^\circ$ , only showing colours from violet to blue.

R. ASHINGTON BULLEN, F.G.S.

Loughrigg, Reigate.

EYES OF INSECTS.—The eyes of insects make very good objects for the experimental microscopist. The number of facets varies according to order, species and sex. Amongst the ants, in *Formica pratensis*, the male has 2,400 facet-eyes, the female, 1,700, and the worker, 1,300. The house-fly has 4,000; the cockchafer nearly 9,000; the dragon-fly nearly 24,000, and in one butterfly nearly 35,650 have been counted. The lens-like nature of each facet may be tested in the following manner: place the microscope, fitted with a half-inch objective and B eyepiece, in a horizontal position at the back of a room, with the objective pointing to an open window. Focus so that the hexagons of the eye show distinctly; move the objective gradually away from the slide till the hexagonal network becomes dim, and in the centre of each facet will be seen the windows and all the objects houses, trees, cattle, etc.—that may happen to be outside.—*J. H. Cooke, Lincoln.*

## SCIENCE IN SOME MAGAZINES.

NOTICES BY JOHN T. CARRINGTON.

HARPER'S MONTHLY MAGAZINE (New York : August, 1897. 1s.). There are two articles in this number devoted to science. "The Century's Progress in Physics," by Henry Smith Williams, M.D., is a second part, and deals with "Ether and Ponderable Matter." Dr. Williams discusses the "ether" filling the inter-planetary and inter-stellar spaces, commencing with Thomas Young's discovery of the "something" which pervades the whole "space" of the Cosmos. It was Young who gave it the name of "luminiferous ether." The author carries his readers through experiments of Fresnel and Arago with polarization of light, Michael Faraday's investigating, the theories of J. Oliver Lodge, Lord Kelvin, Professor Crookes and others. It is an interesting article on a difficult subject. Mr. Fletcher Osgood's contribution is of more popular character, and is prettily illustrated with five reproduced photographs. It is entitled, "A State in Arms against a Caterpillar," and describes the costly war of the authorities of the State of Massachusetts against the larvae of the "gipsy-moth," which defoliates the ornamental and other trees of that part of North America. It is stated to have been introduced, about quarter of a century since, by a French savant to a suburb of Boston, Mass., since which it has spread to such alarming proportions that its destruction has become a serious annual expense. Indeed, the fear exists that the nation will have to combat the spreading evil, as it is too large for the resources of a single State.

THE ENGLISH ILLUSTRATED MAGAZINE (London : August, 1897. 6d.) Mr. Edward Clodd contributes a short article on the "Scientific History and Progress in Great Britain during the Queen's Reign"; which is illustrated with a dozen small medallion portraits of its leaders, past and present. The story is sketchily told in five pages, which space is impossible for anything like details of those many events, great in science, which will make the Victorian era known to inestimable generations of people unborn.

THE CENTURY MAGAZINE (New York and London, August, 1897. 1s. 4d.) contains a most interesting article, illustrated by fine portraits, upon John Burroughs, the inimitable American writer on country lore. As a prose poet and writer about wild things, few have excelled. To those who are not familiar with his works, we would advise his books for a course of reading. It will cultivate elegance of expression and delicacy of thought. The article is by Hamilton Wright Mabie, and is well worth reading. There are two portraits accompanying the letterpress, both of which represent Burroughs as an elderly man.

THE WESTMINSTER REVIEW (London : August, 1897. 2s. 6d.). The place of honour is given to a thoughtful article by Mr. W. J. Corbet, M.P., on the influence of heredity as propagated by the 15,000 persons who "are annually discharged from asylums in England and Wales, some cured, others uncured, but all with the insane taint in their blood." The enormous increase in lunacy among highly civilized races during the last three decades is a fact which is beginning to attract serious attention, and we are glad to see Mr. Corbet return to it in this article, which, from many points of view, is highly suggestive.

HARPER'S MAGAZINE (New York and London : September, 1897. 1s.). The only "nature" article in this month's "Harper" is, in four pages, on "The Milk Weed" (*Asclepias cornutata*), which is as prettily written as illustrated. This is one of the plants which captures insects in the flowers, though they are not insectivorous in the sense of the sundews or pitcher-plants. It is written by William Hamilton Gibson.

LEISURE HOUR (London : September, 1897. 6d.). Mr. Henry Walker, F.G.S., introduces to the readers of that magazine, in an appreciative article, the Rev. Dr. Dallinger, D.Sc., LL.D., F.R.S., F.L.S., the eminent microscopist. William Henry Dallinger is a Plymouth man, born in 1841. His parents were members of the Church of England, though the subject of this notice is as eminent a divine of the Wesleyan Church as a man of science. Attached to the pursuit of natural history from early boyhood, he has, notwithstanding his theological studies and ministry, found time to place himself in the first rank of microscopists. His scientific investigations have been in the neighbourhoods of Faversham and Ashford (in Kent), Cardiff, Clifton (near Bristol), Liverpool, Sheffield (where he was Principal of Wesley College), and at Lea, in North Kent, where he has resided for some time without pastoral charge, following the bent of his highly scientific mind. He has held the office of Rede Lecturer at Cambridge.

THE DAILY MAIL.—This young London newspaper which has so successfully bidden for popularity, has what its editor chooses to call a "Daily Magazine." It frequently contains matters of interest to "the man in the street." There is, however, a responsibility as a teacher of the crowd attached to the editing of such a paper, which in this instance does not seem to be fully appreciated. We may refer, as an instance, to the issue of August 16th last, where appears one of the most silly articles we have read for some time, entitled "Butterfly-hunting." We would recommend the writer to get his facts before committing his teachings to the wide world. When will there be a science censor for newspapers?

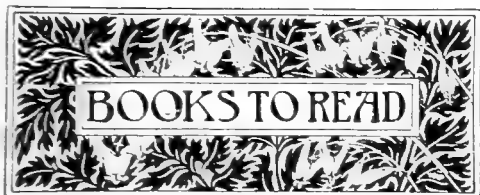

NOTICES BY JOHN T. CARRINGTON.

*The A B C of the X-Rays.* By WILLIAM H. MEADOWCROFT. 188 pp. 8vo. with 5 full plates and other illustrations. (London: Simpkin Marshall, Hamilton, Kent and Co., Limited, 1897.) Price 4s.

This little book is, we believe, of American origin, this being the English edition. As its title suggests, it is a sketchy account of the Rontgen discovery: but the story of its progress and recent application is told with clearness and simplicity. The illustrations are of the usual type, though nearly all differ in individuality from those which have appeared in other works on the subject. We consider this is one of the best of popular books on X-rays and their scientific application.

*A Bibliography of Gilbert White.* By EDWARD A. MARTIN, F.G.S. 274 pp. 8vo. with three illustrations and plan. (London: The Roxburgh Press.) Price 3s. 6d.

Under the auspices of the Selborne Society Mr. Martin has gathered a useful and apparently exhaustive history of the various editions of Gilbert White's "Selborne." The author has evidently given considerable attention to his work, and states that he has found seventy-three separate editions of this favourite book. The illustrations are reproductions from those in the quarto edition of 1813. They are of "The Plestor," "Selborne Church," and "Gilbert White's House." Mr. Martin has produced quite a successful book, for every chapter contains something to please the lover of country lore. His choice and arrangement of matter has been discreet, and shows signs of judicious pruning. The author states that "there appears to be, at the present time, a greater demand than ever for Gilbert White's classic. It requires, I am firmly of opinion, but little annotation. It speaks for itself in its own incomparable style." "Mitford's notes (in the 1813 edition) are admirable, and Professor Bell did well to admit these to his edition and none other." Chapter iv. in the book before us is the most important, for it summarises the various editions known to Mr. Martin, with short descriptions of each. Not the least interesting page in the book is the author's account of the sale of White's original manuscript of the "Natural History and Antiquities of Selborne," and other relics, which took place at "Sothely's," on April 26th, 1845, when this MS. alone fetched no less than 280 guineas. The perusal of Mr. Martin's bibliography reminds, with satisfaction, the writer of this notice that it was in consequence of an article written by him in the "Field" newspaper, while he was connected with its editorial department, that the beautiful triptych was restored and returned to its place, adorning the interior of Selborne Church. That article, published some ten years ago, was entitled, if we remember rightly, "A Pilgrimage to White's Selborne." In it the writer described, with a protest, his discovery

of the triptych in a dilapidated condition in the vestry. Several of the county papers reprinted the article, and the result was evident some time later in a county subscription for the restoration of the panels and their replacement in the church. It will be remembered that the three panels are painted on wood by an early artist, the subject being the "Adoration of the Magi." It was given to the church by Gilbert White's brother, Benjamin, and is illustrated in the edition of 1813 of White's "Selborne."

*The Fauna and Flora of Radley and the Neighbourhood.* By the Radley College Natural History Society. 44 pp. 8vo. (Oxford: James Parker and Co., 1896.)

This little work is a beginning, and forms an excellent basis for further work, to be incorporated in future editions, giving some more detailed account of the animals and plants of the Radley district of Oxfordshire. There is much work to be done by the college society, and we understand that its members are determined to do it. Already, though this first edition was only recently compiled, we hear of many additions having been made to the list. School-boys, if properly guided by their elders, and especially by "old boys" who have become elders, can do as much or more than many other people towards recording the fauna and flora of a district. How much could be done by a large school if only a short space of time were spared during the play-hours, for natural history, from the everlasting football and cricket, which are by no means the "be-all" and "end-all" of school life. We should then see fewer "loafing Johnnies" at drinking-bars in the days when they have left school. Loafing comes largely from want of self-resource and absence of intelligent occupation. The men who are happiest in life are those who find employment for their spare time, in addition to the daily routine of bread-winning. The Radley list will certainly before long become much amplified, but as we have said, it is a basis. Cataloguing advances far more satisfactorily when every novelty is an "addition"; for each record becomes an incentive to work. This first edition is practically anonymous, but it would be well in future to give the names of the captors of future novelties and of the committee of editors. This is desirable, first, as an authenticity of the records, and, secondly, because when the present boys become very "old boys" it will be a satisfaction to them to refer to the work of the old days. The practice will also be provocative of emulation among the boys, which of all things is most conducive to energetic work.

*Publications of the U.S. Department of Agriculture.* Division of Entomology. (Washington: 1896-97.)

Among other literature issued by the Department, we have recently received pamphlets, in most cases finely illustrated, on "The Asparagus Beetles," by F. H. Chittenden; "Insect Control in California," by C. L. Marlatt; "The Use of Steam Apparatus for Spraying," by L. O. Howard, Ph.D.; "The San Jose Scale and its near Allies," by T. D. A. Cockerell. They all contain much useful information, not only for Americans but also for Europeans.

*A Companion for the Queensland Student of Plant Life.* By F. M. BAILEY, F.L.S. 133 pp. 8vo. (Brisbane: Edmund Gregory, 1897.) Free of price.

Mr. Bailey, who is the Government Botanist for the Colony of Queensland, has done well to induce

the authorities to print a second and enlarged edition of this useful work. By its aid a large interest should be created in the study of the plant-life of that magnificent botanical region of Australasia. His system in the pages before us is good, and one likely to encourage botany rather than frighten the public with technicalities. The author explains step by step as he goes along, and quotes familiar local plants to illustrate his remarks. Thus he passes through structure to general classification, and even gives a chapter of useful notes on growing native plants, as well as on horticulture generally. The main part of the book is devoted to an exceptionally full glossary of botanic terms, and those relating to the functions of the various organs of plants. Some of these explanations are lengthy and all are generally admirable. This glossary occupies no less than sixty pages.

*Nature-Chat*. By EDWARD A. MARTIN, F.G.S. 141 pp. 8vo. (London: R. E. Taylor and Son, 1897). Price 1s.

This is No. 1 of the Rambler's Library; though we do not quite see the connection between this little work and the title of the Library. Its contents are a number of short paragraphs on all sorts of items, from "An Unfortunate Porpoise" to "Philatelic Rats"—they are chatty notes on various natural history subjects. In his preface the author says he has collected many of them from letters which he has written from time to time to friends. To the lover of "tits-bits" literature there is plenty of variety in this book. It is just the sort of work one would place by one's bedside for the final read before sleeping. Many of the paragraphs are interestingly written, whilst almost all are suggestive of some train of thought or familiar event. Why, however, does Mr. Martin adopt the newspaper affectation of writing his scientific nomenclature without capital letters? This applies to both family and generic names, though frequently his specific names are so adorned; as, for instance, on page 67, where he gives the scientific name of dyer's rocket as *reseda Luteola*, so setting at defiance the now generally adopted rule of the British Association Committee on Nomenclature, using a capital letter for the generic and a small letter for the specific name, whatever its origin. In this book Mr. Martin is quite free in his treatment of capitals, as they appear in different pages in all ways. We can recommend "Nature-Chat" as amusing for a railway journey or other interrupted reading.

*Rambles Round London*, By "ALF. HOLLIDAY." 65 pp, illustrated. (London: R. E. Taylor and Son, 1897.) Price 6d.

Messrs. Taylor's Rambles Series has been noticed in other volumes of SCIENCE-GOSSIP; this is No. 16 of the series. It forms the second part dealing with the Northern Heights, and comprises walks around Windsor, Ruislip, Colnbrook, Uxbridge, Slough, Taplow, Burnham Beeches, and other rural towns and villages. As itineraries these little books are very useful; they also occasionally indicate points of interest by the way.

*The Tourist Guide to the Continent*, issued by the Great Eastern Railway Company, will be found entertaining to persons travelling by that route. The edition for this season has several additions. Its price is sixpence. We cannot satisfactorily notice the copy before us, as it consists of a number of pages in duplicate and otherwise.



BRITISH HEPATICAE, NEW LIST.—At the suggestion of the Moss Exchange Club, the Rev. C. H. Waddell, B.D., of Saintfield, co. Down, has prepared an exchange list of the British Hepaticae. It appears as an eight-page octavo pamphlet. The arrangement followed is, with slight exception, the classification of the late Dr. Richard Spruce. The list contains many additions to the British list of Hepaticae since 1881, which was the date of the second edition of the London catalogue. Perhaps this new catalogue may err slightly on the side of fulness in the number of species inserted as British, but in the present state of knowledge of the liverworts this may be a fault on the right side. This list includes fifty-nine genera and 220 species. Where there are synonyms they are printed in italics; and on looking through, the students of this group of cryptogamic botany are to be congratulated on the comparatively small number of duplicate names. The study of liverworts appears to be finding greater attention than formerly, and it should receive an impetus now that the workers therein have two such useful and modern aids as Dr. M. C. Cook's handbook and Mr. Waddell's check list. This list may be obtained direct from Mr. Waddell or from Messrs. W. Wesley and Son, Essex Street, London; its price is sixpence.

SANDHILLS AT FLUSHING.—A week or two ago I stayed for a few days at Flushing. The coast of the island of Walcheren, in which it is situated, is guarded by high sand dunes. There is an abundance of the beautiful blue grass called lyme-grass (*Elymus arenaria*). I do not know whether this occurs here naturally or artificially, as it is much planted on dykes on account of its long, creeping, underground stems, which, binding the sand together, serve to prevent the encroachments of the sea on the one hand, and of the sand itself on the land on the other. The leaves of this grass are of great length and some breadth, and look very beautiful in the sunshine. The sand was also in many places carpeted with the handsome rose-coloured flower of the sea-bindweed (*Convolvulus soldanella*). Another very frequent plant was the lesser meadow-rue (*Thalictrum minus*, var. *maritimum*). Small shrubs of the sea-buckthorn (*Hippophae rhamnoides*) were dotted here and there, but they were all devoid of spines. Another feature was the narrow-leaved hawkweed (*Hieracium umbellatum*), while of course almost all the ordinary sea-side plants, such as *Eryngium*, *Euphorbia*, *Crambe*, *Glaux*, etc., put in an appearance. Of insects, the rock-eyed under-wing, or grayling butterfly, was particularly abundant, and in a short walk I noticed half-a-dozen specimens of the swallow-tail butterfly, which apparently had rather a curious flight, the wings being only partially expanded. I wish some of your readers would let me know whether this insect approaches our shores so nearly in other parts of the Continent, and, if so, why it is so seldom found on our coasts.—S. Arthur Sewell, *Maplestead, Buchhurst Hill, Essex*.



CONTRIBUTED BY FLORA WINSTONE.

CATALOGUE OF A COLLECTION OF BIRDS OBTAINED BY THE EXPEDITION INTO SOMALILAND. (Chicago, 1897.) This is No. 2 of the Ornithological Series of the publications of the Field Columbian Museum. D. G. Elliott, F.R.S.E., gives the descriptions of the new species which were obtained by himself and party while going through Somaliland into Ogaden. The chief object of the expedition was to procure specimens of the mammals inhabiting the country, therefore very little attention was paid to the birds. In this catalogue Mr. Elliott has followed the arrangement adopted by Dr. Sharpe in his lists of the birds obtained by Dr. Donaldson Smith in his journey to Lake Rudolph. Three new species belonging to the Family Alandidae are described, one of Sylviidae, one of Turdidae and one of Falconidae.

LA FEUILLE DES JEUNES NATURALISTES. (Paris, August, 1897.) M. E. Simon continues his series of articles on the "Revision of the Genera of Trochilides," and is still dealing with the true humming-birds. Dr. L. Gêneau de Lamarrière commences a series of "Synoptic Tables of the Family Helvellaceae," illustrated with two plates containing thirteen figures. Some "Notes upon some Shells of Cerithiidae from the Eocene Stratum of Paris," by M. L. Vignal, will be continued in the next number, which will also contain plates of the species described. The family of Cerithiidae is one of the most numerous of fossil mollusca. It is represented in the basin of Paris by more than 260 species. M. H. Christ contributes a short article "On the Researches in Botanical Geography." His remarks are founded on M. G. de Lamarrière's request, mentioned in a previous number, that local botanists would observe and note with care the geographical limits of certain plants. Those proposed to be especially noted are *Daboecia polifolia*, *Conopodium denudatum*, *Wahlenbergia hederacea*, *Lifaris loeselii* and *Malaxis aludosa*.

TERMÉSZETRAJZI FÜZETEK. (Budapest, June, 1897.) In this number, which contains five most beautifully coloured plates, illustrating various articles, Professor L. de Méhelij contributes some notes on "Further Contributions to the Herpetology of New Guinea." They are an account of seventeen species of Batrachia and Reptilia sent to the Hungarian National Museum in January last by Lewis Biró, with other material he had found during his explorations in New Guinea. These specimens are from the coast and small islands between Berlinhafen and Frederick-Wilhelmshafen of German New Guinea. They include representatives of species hitherto unknown to science, and form a valuable addition to the known reptiles of New Guinea. There is one plate illustrating this article which contains figures of two new species of Batrachia, *Sphenophryne biró* and *Hyla boulengeri*. An article on the "Formicidens of Ceylon and Singapore" is by Dr. Gustav Mayr. He describes species found by Dr. Julius

V. Madrász in Ceylon and M. Ludwig Biró in both Ceylon and Singapore, and given by them to the National Museum of Hungary. The new species are *Ooceraea coeca*, *Ponera ceylonensis*, *Anochetus madaraszi*, *A. longifossatus*, *Cremastogaster biró*, and *Tetramorium curvispinosum*. Dr. Ludvico Biró gives an account of three species of Coleoptera new to the fauna of Hungary, found by himself, they are *Drimoctus chyzzevi*, *D. entzii*, *D. horváthi*.

CONTRIBUTION II. TO THE COASTAL AND PLAIN FLORA OF YUCATAN. (Chicago.)—This publication, No. 3 of the Botanical Series, is by Dr. Charles Frederick Millspaugh, Curator of the Department of Botany. The part of Yucatan considered in these contributions is peculiar in its biologic characters, differing especially in its flora from the surrounding country. In the immediate neighbourhood the wealth of vegetation is very marked, while here the plants have to struggle against continual drought, producing a very desiccated appearance. The principal collections represented in this catalogue were made in 1895, the driest period known on the peninsula for over half a century, as there were only three months of partial rain. The basis of the collections is one made by Dr. Gaumer, consisting of about 600 specimens collected chiefly from the neighbourhood of Izmal in the interior, and at the town and port of Silam on the northern coast. The catalogue also includes about a hundred medicinal plants, sent for identification by Professor H. H. Rusby, of New York, having been collected by one of his pharmaceutical students named Sr. Porfirio Valdez, of Merida; a collection made by the author at Progreso, Merida, and Tikul in 1887; also a few plants of the Allison V. Armour Expedition of 1895. The catalogue has a useful index, including one of local Maya names, and is most beautifully illustrated with thirteen plates and an outline map of Yucatan.

PORTLAND SOCIETY OF NATURAL HISTORY. (Maine, U.S.A. Vol. ii., part 4.) Mr. Arthur H. Norton has a paper on the "Sharp-tailed Sparrows of Maine" in this number of the Society's "Proceedings." There are, according to the author, at least two forms of sharp-tailed sparrows worthy of specific rank in the State of Maine. The so-called var. *nelsoni* of *Ammodramus caudacutus* appears to have some characters which not only separate it from the common sharptail (or more correctly, Lady Blackburn's finch), but enable it to have its own sub-species in the var. *subvirginatus*. These birds are migrants in Maine, wintering some distance south, even as far as the countries surrounding the Gulf of Mexico. Mr. Norton differentiates these species and varieties of sharptails. In the same number of the "Proceedings" Mr. Norton mentions two horned owls new to the fauna of Maine, and other birds new to the Portland list. Mr. Frank S. Norton read a paper, which is printed in this number, on the "Foraminifera of the Marine Clays of Maine," which is illustrated by a plate with a couple of dozen drawings. Most of the material from which this paper is compiled was gathered by the late Charles B. Fuller, at Munjoy Hill, eighty-seven feet above high-water mark. The clay obtained there proved rich in Foraminifera, Ostracoda and other microscopic fossils. The author refers to forty-five species, twenty-three of which are figured. In this number appears also a "Second Supplement to the Portland Catalogue of Maine Plants," which indicates great activity among the local botanists.



SHREWSBURY has honoured the name of Charles Darwin by erecting a bronze statue to his memory in that, his native, town.

DR. ARMINIO NOBILE, Professor of Geodesy in the University of Rome, and author of several astronomical works, has passed away.

MR. G. J. SYMONS, F.R.S., the veteran meteorologist, states that there have been six months of July in the last forty years as dry, or drier, than that recently passed, which was thought by many to have been the driest on record.

A NEW IRISH ALGA.—Professor T. Johnson exhibited at a recent meeting of the Dublin Microscopical Club, *Streblonema minimum*, a microscopic alga new to the Irish marine flora. It was taken at Dungarvan in October last, and had been worked out by Miss M. C. Knowles.

MR. ROWLAND WARD, of Piccadilly, records the capture, off the coast of Aberdeen, of a rare fish (*Lampris luna*), the opah, or king fish. The specimen weighs sixty pounds, and was, when fresh, one of the most handsomely coloured of fish.

MISS CATHERINE W. BRUCE has given 1,500 dollars to Professor Rees, of the Columbia University Observatory, to be employed in publishing the observations and reductions for "Variation of Latitude," etc., made by himself, Professor Jacoby and Dr. Davis.

IN "Science" for 25th June, Mr. T. D. A. Cockerell gives an interesting account of the Virginia colony of *Helix nemoralis*. Many new variations different from those observed in Europe have occurred in the colony since they were first placed at Lexington.

WE have to record the death of M. Doumet Adanson, a descendant of the celebrated naturalist, Adanson, who devoted his life to scientific researches and the amalgamating of large natural history collections. At his park at Baleine, he had a number of species of exotic trees, some of which were the only specimens in France.

FROM Wady Halfa, on August 23rd, a journalist describes the rapid progress, on its way south, of the new Nile Railway. This line is sure to be of great importance for the scientific, and especially anthropological, examination of the desert region.

HE states that the mirage is seen everywhere. The labourers appeared to be working into a beautiful lake. "One seems to see on all sides, lakes, beautiful wooded hills, ships, boats and cascades. When examined through field-glasses the illusion is heightened rather than diminished."

WE do not know whether the disappearance of the mirage in the upper Nile Valley is similar to that of the plains of North-Western America; but our experience of that stage is even more astonishing than its appearance. It frequently goes away in patches, leaving little islets, as it were, dotted about over a landscape quite unlike the illusion.

PROFESSOR LANGLEY, of the Smithsonian Institution, recently received a warm welcome on the part of French aeronauts at a meeting of the French Academy of Sciences. In reviewing his work, he stated he had obtained excellent results with his steam aeroplanes. These discoveries will shortly be published for the advantage of those working at aerial navigation.

THE motor-carriage industry proceeds with lagging steps. The handsome prize of £1,000 offered by a London engineering contemporary for the best cars in a competition, failed to bring out any carriage fulfilling the simple requirements laid down for the trials.

THERE have, however, appeared in the London streets about a score motor-cabs, which are plying for hire. They are driven by electric motors, which are stored, with the batteries, under the seat and floor of the carriage. When the driver applies the break, the same action cuts off the electric current from the motor, so adding to the ease of stopping.

THE meeting of the British Association was held at Toronto, in Canada, commencing on August 18th, when about 1,500 members and associates attended, 400 of whom were from England. Sir John Evans gave the presidential address, which was really a defence of Archaeology as one of the sciences. The subject of the address was largely the Antiquity of Man.

IN the section for Geology at the British Association meeting at Toronto, the President, Dr. G. M. Dawson, C.M.G., F.R.S., of the Canadian Geological Survey, gave a long and interesting address on the "Geology of the Northern Continent of America."

PROFESSOR L. C. MIALL, F.R.S., who was the sectional President for Zoology, took several subjects for his address. These included the "Study of Live Animals," "Life-history of Eels," "Life in the Deep Sea," "Adaptability of the Lower Animals," and "Contrast with the Vertebrates."

PROFESSOR H. MARSHALL WARD, Sc.D., F.R.S., President of the Botanical Section, took chiefly for his subject the "Consideration of the lower forms of plant-life," such as bacteria.

THE De Gerlache expedition to the Antarctic regions started from Antwerp on August 16th, under pleasant auspices and much honour. It will call at several South American ports on the way, and expects to reach the southern ice regions soon after Christmas.

THE Treasury have appointed a Committee, on which we note the names of Lord Rayleigh, F.R.S. and W. C. Roberts-Austenn, to report upon the establishment of a national physical laboratory for testing and verification of instruments, for physical investigation, and the preservation of the standards of measurement.

MR. ALBERT MARTH, for many years an active Fellow of the Royal Astronomical Society, died recently whilst on a visit to his native country of Pomerania. He was, for some time, connected with the observatories of Regent's Park, Durham and Malta. He was the discoverer, in 1854, of the planet Amphitrite, or, No. 29. For the last nine years he has had charge of Colonel Cooper's observatory in County Sligo. He was sixty-nine years of age.



CONDUCTED BY FRANK C. DENNETT.

		Rises.	Sets.	Position at Noon.	
		h. m.	h. m.	R.A.	Dec.
Sun	Sept. 4	5:11 a.m.	6:38 p.m.	10 54	7° 3' N.
	14	5:35	6:16	11 30	3° 13'
	24	5:51	5:52	12 6	0° 40' S.
Sept.		Rises.	Sets.	Sets.	Age at Noon.
	1	6:00 a.m.	7:22 p.m.	10 9	7 8 21
	11	6:25	1:56 a.m.	9 34	17 8 21
	21	6:41	1:02	4 46	27 8 21
				Position at Noon.	
	Sept.	h. m.	Semi-Diameter.	R.A.	Dec.
Mercury	4	12:27 p.m.	47"	12 21	6° 7' S.
	14	12:44	51"	12 59	0° 32' S.
	24	11:57 a.m.	57"	11 42	1° 33' S.
Venus	4	9:27	7 3	8 24	18° 53' N.
	14	9:27	6 9	9 12	16° 20' N.
	24	9:45	6 6	9 59	13° 0' N.
Mars	14	11:57 p.m.	17"	12 48	4° 39' S.
Jupiter	14	11:54 a.m.	11"	11 23	4° 33' N.
Saturn	14	4:3 p.m.	7 4	15 36	17° 25' S.
Uranus	14	5:38	17 8	15 34	19 1' S.
Neptune	14	6:6 a.m.	17 2	5 28	21 53' N.

MOON'S PHASES.

	h. m.		h. m.
1st Qr.	Sept. 3 ... 11:3 p.m.	Full	Sept. 11 ... 2:12 a.m.
3rd Qr.	" 19 ... 2:51 a.m.	New	" 26 ... 1:46 p.m.

In perigee, September 1st, 10 p.m., distant 229,200 miles; in apogee, September 17th, 5 a.m., distant 251,500 miles; and again in perigee September 28th, 12 p.m., distant 226,200 miles.

CONJUNCTIONS OF PLANETS WITH THE MOON:

Sept. 2	Saturn*	10 p.m.	planet 6° 57' N.
21	Venus*	12 p.m.	" 2° 48' N.
27	Jupiter*	12 p.m.	" 5° 27' N.
26	Mercury*	3 a.m.	" 2° 35' N.
27	Mars*	11 p.m.	" 5° 44' N.
30	Saturn†	9 a.m.	" 6° 36' N.

\* Below the horizon in England. † Daylight.

OCCULTATION AND NEAR APPROACH:

	Time.	Angle from Vertex.	Re-appears from Vertex.	Angle from Vertex.
1	1:24 a.m.	1 52	7:2 a.m.	215°
2	1:42 a.m.	45		Near approach.

THE SUN has now frequently some spots on its surface. A large group crossed the disc during the first half of August, the large leading spot readily showing the presence of nuclei in its umbra. These are usually more easily seen during the period when solar disturbances are at a minimum. Volcanic eruptions are said to commence at 7 p.m. on 22nd, when the sun enters Libra.

MERCURY is the evening star until the 22nd at 7:30, after which it is a morning star, is not to be seen until the 1st of observation. On September 23rd, at 12 p.m. Mercury is in conjunction with Jupiter, and is 2° 17' to the north.

VENUS is a morning star all the month, rising at the beginning at 1:20 a.m. and 2:50 a.m. at the end. Its apparent diameter contracting as the disc slowly approaches the circular form.

MARS and JUPITER are too near the sun for observation, the latter being in conjunction with the planet Saturn on September 13th.

SATURN sets at 9:22 p.m. on 1st, and 7:33 on 30th, so must be looked for as soon as it is dusk. Its rings are very grand.

NEPTUNE is in Taurus, 4' south of the wonderful "Crab" nebula, I. Messier, a little N.p. the 3rd-magnitude star marked ζ.

METEORS may be looked for September 1st-2nd, 6th-7th, 11th-13th and 25th, especially during the earlier days.

RED STARS IN POSITION DURING SEPTEMBER:

	R.A.	Dec.	Magnitude.
	h. m.		
B. 658 Cassiopeia	23:55	59° 41' N.	7.8 Variable
R "	23:52	50° 43' N.	4.8-12 Very red, variable
T "	0:17	55° 8' N.	6.5-11 Variable
— "	0:3	63° 11' N.	8.5
— Andromedæ	0:13	43° 56' N.	8.2

ERRATUM.—After the declination of the last star in our August list, the + (plus) mark should read ± plus or minus — more or less.

D'ARREST'S COMET.—This faint object was picked up at the Lick Observatory by Mr. Perrine, on June 29th, in the north-eastern part of Cetus (R.A., 2h. 1m.; Dec. N., 6° 14'), and has since been observed at Algiers and Toulouse. Its diameter is said to be about 1', it is very faint, but has a very slight condensation. Its path has been eastward, very slightly inclined towards the equator. By the time this is in the reader's hands, it will be in the southern part of Taurus, only a little N.p. 44 Eridani. It has a period of 6.691 years, and so may be expected again in 1903.

YERKES OBSERVATORY will be formally dedicated on October 1st, when it is hoped that many of the scientific visitors to the meetings of the British Association for the Advancement of Science gathered at Toronto will be able to attend.

A RAPID BINARY STAR.—In 1879, Mr. S. W. Burnham, one of the most acute observers we have for double stars, discovered with the 18½-in. Chicago refractor, that the star marked Lalande, 9091 in Taurus, is a close double, 7.8 and 8 magnitudes, and it is now named β. 883. In the "Monthly Notices of the Royal Astronomical Society" for June, Dr. I. J. J. See points out that this pair are really a binary system with the abnormally short period of 5.5 years, the shortest known amongst visible doubles.

THE THOMPSON PHOTOGRAPHIC TELESCOPE.—Mr. Goschen, in answer to a question in the House of Commons, on July 26th, stated that, as soon as arrangements can be completed, the public will have an opportunity of purchasing such photographs, taken with this instrument at Greenwich, as the Astronomer Royal may deem suitable for issue.

BRILLIANT METEOR.—News is to hand of a brilliant, slow-moving meteor, seen in the south of England about 8.45, on the evening of July 30th. Its colour was white, with a tinge of blue, and it had a short trail. Its course was almost directly on the line of the meridian. Its brilliance is said to have been much above that of Venus when at its best. It also threw off some brilliant sparks before its disappearance. Any further details would be welcome. A Southampton observer, Mr. S. Stainer in the "English Mechanic," describes it as starting from "a point a little south of the zenith," and its path towards the south, "roughly speaking, about 35°."



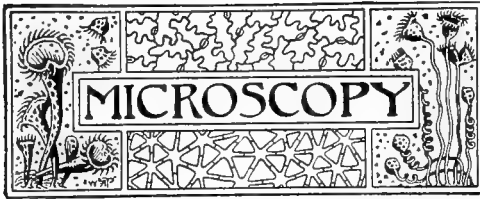

CONDUCTED BY J. H. COOKE, F.L.S., F.G.S.

To whom Notes, Articles and material relating to *Microscopy*, and intended for *SCIENCE-GOSSIP*, are, in the first instance, to be sent, addressed "J. H. Cooke, Thorndale, Lincoln."

**CRYSTALLIZATION OF OILS.**—In his report to the Secretary of the Department of Agriculture, U.S.A., Mr. Thomas Taylor, the microscopist to the Department, has illustrated a very ingenious freezing-box for use with the microscope, whereby the various oils and their acids may be crystallized so as to obtain micro-photographic views of their respective crystalline arrangement. Another advantage offered by this invention is that by this method objects in natural history mounted in varnish or other media may be thrown on a screen and photographed.

In the accompanying copy of his drawings, A represents the microscope, B the freezing-box made of brass or of German-silver, and attached to the substage of the microscope by means of two clamps, one on either side of the box. B is a separate view of the apparatus; *a* and *a'* represent tubes, one of which supplies a freezing liquid, the other carries it off. A pail to receive the waste liquid is in readiness, and is connected in the usual way by means of rubber tubing; *c* is an opening through the centre of the box, which admits of the transmission of rays of light to the object under investigation. The freezing may be used repeatedly, or until it ceases to be cold enough for the purpose. Ammonia, ether, or any other freezing liquid may be used.

**CHAULMUGRA FAT CRYSTALS.**—Numerous experiments have been conducted by Mr. Taylor with this apparatus, all with gratifying results. The very peculiar forms which the fat of chaulmugra oil assumes in crystallizing led to the discovery that it was an hitherto undescribed fat. It was mounted in the usual way. It was then sufficiently heated to make it liquid, and was placed quickly under the microscope. As it cooled, crystallization rapidly progressed. At first globular masses were observed, each one showing, under polarized light, a well-defined cross. As soon as these globular masses have formed, a second crystallization takes place, proceeding from the globular accretion in the form of an elongated spreading fan. (Figs. 1 and 2 on next page.)

**DISTRIBUTION OF HYDRA.**—Alluding to the distribution of *Hydra* in his recent address to

the Manchester Microscopical Society, Professor S. J. Hickson remarked that if hydras be examined we shall find that in the summer and autumn months they produce small swellings or protuberances on the sides of their body-walls, and each of these contains a small brown body. A careful examination with the microscope shows that these brown bodies are really eggs which are covered by a tough, horny shell. This in itself is a remarkable fact, for in the large group of animals to which *Hydra* belongs, including all the Hydroids, jelly-fishes, corals and sea-anemones, this is the only genus that possesses such a covering on the eggs. Moreover, *Hydra* is the only freshwater Coelenterate which has a world-wide distribution, and if these two facts be placed side by side we must arrive at the conclusion that *Hydra* owes its wide distribution to the fact that it produces eggs which are so well protected that they can resist the dangers of a passage through the air.

**MUSHROOM SPORES.**—In the identification of a species of the Agaricini it is of the greatest importance that the exact colour of the spore should be determined. These spores are very variable in size, shape, and colour, but they are tolerably constant at maturity in the same species, and even in different species of the same genus. The size of the spores varies from one hundredth to a few thousandths of a millimetre in diameter. Their shape is almost always spherical in the young plant, but afterwards becomes ovate, ellipsoidal, fusiform, reniform, smooth, stellate and sometimes tuberculate. A study of the spores enables one to differentiate between the edible and the non-edible species.

**MICROBES OF DISEASE.**—Diseases have their local habitations, says the "Saturday Review." Some, like tropical animals and plants, live only in the tropics; some, like consumption, are gradually spreading over the whole earth; others, like leprosy and small-pox, are gradually becoming limited in their distribution and may actually be tending towards extinction. Again, there are regions to which diseases have never reached. On the summits of high mountains and in the circumpolar snowfields the earth and air and water are barren of the microbes of disease as they are of animal life. In a country like Britain, thickly populated for many centuries, and with the freest circulation of population, it cannot be doubted that every yard of surface contains the germs of the more common diseases, and the native of some newer land brought over here would fall a victim to our plague-stricken soil. By generations of a destructive elimination we have become highly resistant to our native diseases, just as the Gold Coast natives are less susceptible than we are to their own local diseases. But we are not fully protected, and cancer and consumption—two of our common scourges—still take a

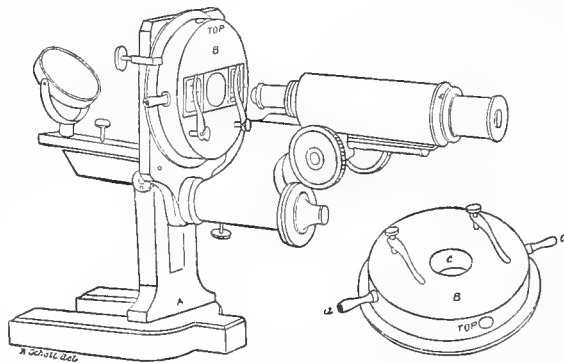

TAYLOR'S FREEZING-BOX AND MICROSCOPE.



large annual toll. It may be assumed that both are due to micro-organisms, the microbe of consumption being well-known, that of cancer being, as yet, only suspected. Probably no inhabitant of Britain escapes infection by the cancer organism; certainly none escape infection by the microbe of tubercle. Most of us, fortunately, resist the intruders and are unaffected by the disease.

**PROCESSES OF CRYSTALLIZATION.**—The processes of crystallization are being studied by Professor von Schroen, who has taken 2,800 micro-photographs to show the transfer of organic into inorganic matter. It seems that this fact led to a recent sensational and incorrect report that crystals had been found to be organic substances.

**MERIDUM CIRCULARE.**—This beautiful diatom may be found in the ooze on the borders of pathways in the woods and in natural parks. To be certain that one has this diatom, we should carry, as part of our collecting outfit, a high-power platyscopic lens, a slide and a cover-glass. Place a drop of the gathering on the slide and cover, and

**FOSSIL BACTERIA.**—From the "Annales des Sciences Naturelles" we learn that M. B. Renault has long worked at the identification of bacteria found in geological strata, and now publishes the general results of his observations in a paper illustrated with a large number of drawings. As might be expected from their simple structure, bacteria appear to have been coeval with the first appearance of organic life on the earth, the coccoid form being apparently earlier than the bacillar. Indications of their presence are found in bone, teeth, scales and coprolites, as well as abundantly in vegetable tissues. Spores and sporanges of ferns appear to have been especially subject to their attacks. The species are, as a rule, distinct from those at present in existence.

**REPRODUCTION OF MARINE DIATOMS.**—In a paper, entitled "On the reproduction of some Marine Diatoms" (Proc. Roy. Soc., Edin.,) Mr. George Murray gives an account of the results of his researches on reproduction in this group. The author has observed in some marine forms a very

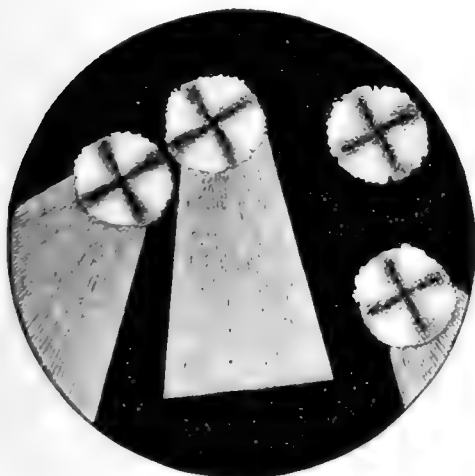

FIG. 1.

CHALUMUGRA FAT CRYSTALS.

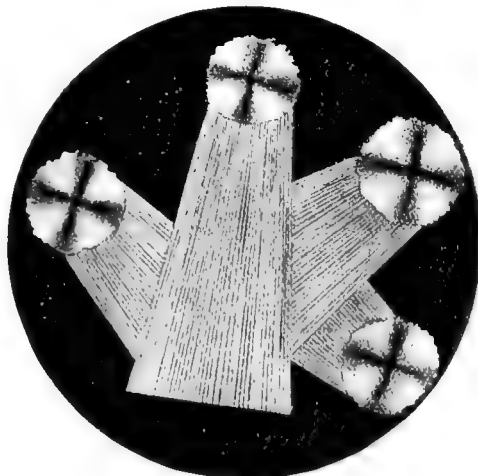

FIG. 2.

view with the lens, when the characteristic rings will be visible, and with them will be observed separate conic frustules. The rings are characteristic on account of their width and disposition of the frustules about the centre.

**POLLENS IDENTIFIED BY POLLENS.**—The "Journal of Pharmacology" contains an interesting paper by Mr. Charles Pfister, on the pollens of official herbs. His enquiry having been undertaken with the view of determining whether the powdered drugs could be recognized by means of any pollen which they may contain. Mr. Pfister's conclusion is that they can, and he submits figures and descriptions which corroborate his statement. Thus the pollen of horse-radish is squarish-oblong, green and smooth; that of wormwood is smooth, elliptical and yellowish; some grains resembling a three-leaved clover. Mr. Pfister does not profess to be exhaustive, but they are suggestive, and are worth following up. He mounted the pollen in sweet almond-oil, without previous preparation, and finished with a ring of gold-leaf.

interesting and totally new method of division. This form of reproduction was observed in *Coscinodiscus*, *Biddulphia*, *Choeboeceros*, etc., but was followed out more fully in the first-named genus. In *Coscinodiscus* the cell contents divide by successive division into eight or sixteen portions, and these become rounded off and lie free in the mother cell like spores in a sporangium. Each of these portions becomes invested with valves showing the characteristic markings, and in fact becomes a young *Coscinodiscus*. These young forms ultimately escape from the parent cell, and are found floating free in the water as packets of eight or sixteen small individuals enclosed in a delicate membrane; later on the several individuals themselves become completely free.

**HOW TO TEST OBJECTIVES.**—In the "Journal of the New York Microscopical Society," Dr. A. C. Stokes publishes a lengthy article on this subject, in the course of which the writer says: A severe test, then, or one that should come within the ability of the objective, and so fulfil the conditions

of the ideal object for the purpose, is, for a first-class four-tenth inch, the black dots of *Pleurosigma angulatum* in balsam, and perhaps, and imperfectly, the secondary structure of *Arachnoidiscus ehrenbergii*; for a one-fifth inch the longitudinal lines of *Surirellagemma*, and the secondary structure, *Isthmia nervosa*, with the postage-stamp fracture; for a one-eighth inch, or for higher powers up to the one-twelfth, the dotted secondaries of *Craspedodiscus elegans* in certain conditions.

**FRUITING-TIME OF VOLVOX.**—What is the usual season of the year during which *Volvox* can be found in fruit? In certain books which I have referred to for information on the matter there are statements to the effect that during the summer *Volvox* is reproduced in the vegetative manner only, but in the autumn sexual organs may be formed. Is the autumn the proper season to find this alga in fruit? I do not know whether my experience is exceptional, but towards the end of June, *Volvox minor*, living in one of my aquaria, was bearing ripe oospores, and examination of a gathering of *Volvox*, made during an outing several days ago, showed both *Volvox minor* and *V. globator* to be bearing abundant fruit.—C. E. Britton, 189, Evesford Street, Camberwell, S.E.; August, 1897.

**FLOUR WEEVILS.**—These little pests are more or less familiar to most of us owing to their marked

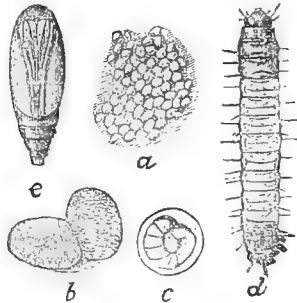

PYRALIS FARINALIS.

a, Egg mass; b, Eggs—more enlarged; c, Egg showing embryo within; d, larva, dorsal view; e, Pupa. All enlarged.—After F. H. Chittenden.

proclivities for the flour-barrel and other receptacles in which farinaceous matter is stored. Mr. F. H. Chittenden, in his "Farmers' Bulletin," No. 45, tells us that owing to the minuteness of size and the paleness of colour of the eggs and larvae of these beetles, they often escape notice; being overlooked, these mature, and in due course the flour is ruined; for when the insects have time to propagate, they soon convert the flour into a grey, useless mass. The accompanying illustration shows it at various stages of the growth of the meal moth, *Pyralis farinalis*, in its three earlier stages.

**LIFE-HISTORY OF THE WATER-MITES.**—The "Journal of the Quekett Microscopical Club" for the current quarter contains some interesting notes, by Mr. C. D. Soar, on Hydrachnidae, in the course of which he records his personal observations regarding the life-histories of the water-mites. The time that elapsed between the laying of the eggs and their development varied very much in different genera; for instance, *Arvenurus caudatus* (De Geer) took twenty-four days, *Nesoea carnea* (Koch) twelve days, *Diplodotus despiciens* (Müll) twelve days, *Eylais extendens* (Müll) thirty-eight days, *Hydradroma*

*rubra* (De Geer) twenty-six days. These developments took place at different dates from March to October, so it will be interesting to note if these great differences are peculiar to the species or to the time of the year. Mr. Soar's observations are rendered all the more valuable by the fact that so little has hitherto been done in this subject. In the same journal Mr. W. B. Stokes explains the origin and behaviour of multiple images in mirrors, a phenomenon which most microscopists have noticed, but which few have sought to remedy or to explain.

**DISTRIBUTION OF PELAGIC FORAMINIFERA.**—Students of the Foraminifera should read Dr. John Murray's article on "The Distribution of the Pelagic Foraminifera at the Surface and on the Floor of the Ocean," which appears in the July number of "Natural Science."

**THE EARTH'S DEVELOPMENT.**—To the microscopist and biologist the origin of life must long continue a tempting subject for speculation. A Philadelphia investigator, Mr. Charles Morris, contends that the conditions favouring the development of organic material were transitory, and no longer exist, such material having arisen from a vitally active stage of inorganic chemistry. There must have been a time in the earth's history, he reasons, when chemical inactivity prevailed on account of high temperature and unfavourable chemical conditions. Chemical activity arose and increased as the heated ocean was formed, and changed the first simple substances into compounds of gradually growing variety and volume. Many resulting complex minerals were probably deposited as rock formations. The ocean having deepened and freed itself from foreign material, inorganic chemical activity gradually diminished, until it has now practically ceased, oxidation having reduced nearly all substances to a state of chemical fixity. With the cooling of the primeval ocean, and the increase of sunshine, came organic chemical activity. The material had been prepared in air and water, and may have had its origin in an early reaction between carbon-dioxide and the elements of water, yielding hydrocarbons, and subsequently, between these and nitrogen, yielding the far more complex albuminous compounds. The complexity of mineral molecules doubtless increased under conditions restraining the activity of oxygen. Seed-forms of organic substance—simple carbon compounds—may have first appeared, and these would serve as the basis of gradually increasing complexity of molecules through a possibly long-continued process of deoxidation and formation of higher carbon and nitrogen compounds, until true organic matter appeared and the chemistry of life had begun.

**BALDNESS MICROBE.**—One of the physicians at a hospital in Paris has, it is stated, discovered a microbe of the skin which accounts for baldness. A sheep and a rabbit has been inoculated with the microbe at the Pasteur Institution, and the results will be made known at an early meeting of the Society of Dermatology.

**QUERIES.**—May we remind our readers that we shall be glad at all times to afford what assistance we can by inserting in these columns their queries on microscopic matter and methods.

**ANSWERS.**—R. Borrow: Your determination is correct. J. T.: Please repeat your query. T. Clarke: The specimen sent is a sheep-tick (*Malophagus ovinus*.)

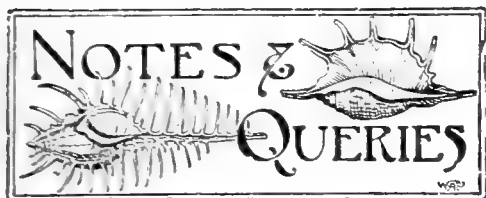

# NOTES & QUERIES

**SLUGS.**—Can any reader of SCIENCE-GOSSIP inform me through its columns: (1) Where I can find descriptions of the known species of *Besonicella* and *Baginula*. (2) Are these two genera synonymous? (3) Who is the principal authority on slugs in this country?—*A. T. Taylor, Heaton; August 16th, 1897.*

**ABNORMAL CUCUMBER.**—I send you a very neatly-coiled cucumber, grown in a frame in our garden. It was in the middle of the frame, with plenty of room to grow straight, but has apparently suffered from disease, or the attacks of insects. Perhaps you can tell me the cause of its eccentricity.—*Frank Sich, junr., Corney House, Chiswick; August 3rd.* The specimen sent has grown into a perfect coil of three turns. It is difficult to suggest the cause of these abnormal growths, especially in this instance.—*ED. SCIENCE-GOSSIP.*]

**DERIVATION OF MICROLESTES.**—In SCIENCE-GOSSIP, vol. iv., page 3, I see Mr. Nunney, writing on nomenclature, in speaking of derivatives, implies that the mammal *Microlestes* is a derivative of the dragonfly *Lestes*, than which, of course, it is much larger. He calls this "undesirable usage," but I think it much more natural and simple to take *Microlestes* as "a small robber." I do not know what author originated the name, but have no doubt that it was in this sense that he wished it to be interpreted, and not as "a small *Lestes*," otherwise a "small dragonfly."—*Malcolm Burr, Bellagie, East Grimstead; August 14th, 1897.*

**CINNAMON VARIETY OF BLACKBIRD.**—I recently obtained from Holmwood, near Dorking, an unusual variety of a male common blackbird (*Turdus merula*), which is of uniform cinnamon colour, excepting the breast, which is nearer cream colour, spotted with brown. The bird was taken soon after it left the nest, as it was entangled in some nets spread to protect cherries. It moulted whilst in my possession, and reproduced its variation in even more accentuated form. I have placed this interesting variety in the Zoological Gardens, Regent's Park, where it may be seen in the western aviary.—*H. J. Lauford Jones, 6, Fitzroy Square, London, W.; July, 1897.*

**HEDGEHOGS CARRYING FRUIT.**—With reference to your correspondent's query as to hedgehogs carrying fruit on their spines (*ante* p. 85), I may mention that several years ago, when I was quartered at Wellington, on the Neilgherry Hills, the porcupines played havoc with my potatoes, routing them up and either eating them or conveying them away. An old staff quartermaster-sergeant, who had been many years in the place, told me that the natives declared that the porcupines collected the potatoes together and then rolled on them, impaling them on their quills, and thus carried them away. I always regarded this statement as one of the "Plain" tales from the Hills, but if hedgehogs employ this method in transporting apples, I do not see why porcupines should not do the same with potatoes.—*Major Stuart, Las Niemas, St. Peter's, Jersey.*

**PRESERVATION OF RARE BRITISH ANIMALS.**—I cannot refrain from congratulating you upon the very proper reply you give in the August number of SCIENCE-GOSSIP (page 63) to the maudlin, sentimental rubbish that lately appeared in the "Saturday Review." With you I quite dislike the destruction of our fauna, and do all in my power to stop it about here. Nevertheless, to put the extinction of species down to naturalists is absurd, as you so well point out in your very able reply. I think your article will be satisfactory to those who study natural science, and personally I thank you.—*Linnaeus Greening, F.L.S., M.R.I.A., 5, Wilson Patten Street, Warrington; July 28th, 1897.*

**PHENOLOGY IN ABERDEENSHIRE.**—Broom has scarcely managed to bloom this year, and what has done so has been at least a month later than usual. There is an astonishing quantity of pease, compared with the flowers, but the growth of the shrubs is fair. Both the fine- and the cross-leaved heaths were later in flowering than usual, as was ling. Then, in gardens, we find the flowering of plants which require much heat is this season weaker; but in cases of deep-rooting plants the blossom is generally superior. Fruit, in many cases, is a failure, being completely frosted away in spring, and some shaken by exceptional winds later on. On agricultural fields we find the hay crop below the average, red clover, especially, having been destroyed. On pasture-fields many more than usual of the sown plants have succumbed and made an opening for the weeds.—*William Wilson, Alford, Aberdeen, N.B.; August, 1897.*

**SIREX JUVENCUS.**—A fine female specimen of this insect, which is not common in London, was captured near Westminster Bridge, on the 7th inst. by Mr. Ernest Ray, and sent to me for identification. It is of a dark purple colour, and measures slightly over one and a-half inches from its head to the tip of the ovipositor, and two inches across the wings when expanded. It has long jointed antennae and formidable mandibles, and when flying produces a loud buzzing noise like that of a humble-bee. Figuiet, in his "Insect World," makes an interesting allusion to this insect, the larvae of which he says possess such powerful mandibles as to enable them to pierce lead, and in corroboration of this statement, he mentions that in 1857, Marshal Vaillant presented to the Académie des Sciences, France, some packages of cartridges containing balls which had been pierced through by these creatures during the sojourn of the French troops in the Crimea, and in which some were found concealed in the galleries they had hollowed out.—*J. C. Webb, F.E.S., Henslowe Road, Dulwich; 16th August, 1897.*

**TRAVELLING ILLUSTRATED LECTURES.**—I take the liberty of approaching you with a suggestion that I have often thought over, and which I think would be best worked out by you as Editor of the only real natural history paper in this country. I know that many secretaries of societies have great difficulty in obtaining papers for their programmes of winter evening meetings, and if some good papers could be compiled and sets of slides got together, they could be circulated and read at meetings, among the societies, with great advantage. In order to do something myself to assist, I am willing to make a set of lantern-slides for the first lecture, from any drawings or pictures that may be required for illustrating such a paper, say from twenty to thirty slides, which is as many as would, I think, be useful, and do them free of any

charge. Perhaps you might find, upon making enquiries, someone else who would assist.—*A. Clarke, Hon Sec. Huddersfield Naturalists' and Photographic Society, 9, St. Andrew's Road, Huddersfield; August 7th, 1897.* [Mr. Clarke's proposition seems well worthy of discussion in these columns. We shall also be pleased to receive offers of aid, and be glad to become the centre of some plan such as is here suggested.—ED. SCIENCE-GOSSIP.]

**HABITS OF LEAF-CUTTING BEES.**—Probably some of your readers may be interested in hearing of, as we were in watching, the movements of a leaf-cutting bee (*Megachile centuncularis*). Early in July of last year it was noticed that a bee was a daily visitor to our conservatory. She would come and go continually, and after buzzing about the pots for a time, she at last set her affections upon a particular orchid and commenced digging a hole in the mould. It was then observed that between her hind legs she carried in pieces of green leaves, which she dragged into the hole. After a few days she began operations underneath, creeping with the leaf through the hole at the bottom of the pot, and gradually turning out the mould as she proceeded with her work. This continued until the end of July, when we left home. Upon our return nothing more was seen of our little friend. Curiosity, however, compelled us, in September, to turn out the orchid-pot, and to our surprise we found seventeen chrysalis-cases, most perfectly and wonderfully formed. They were about three-quarters of an inch in length, and a little more than a quarter of an inch in diameter, formed by oval pieces of rose-leaves of precisely the same size wrapped round and overlapping one another. The edges were apparently gummed to the lower one; the ends of the leaves were brought together at the bottom so as to make it perfectly convex. The other end was fitted with a cap composed of several little circles cut from the leaf with mathematical precision, and set slightly within the edge of the chrysalis, so as to make that end concave. We unwrapped one and found it composed of nine oblong leaves, and five round ones forming the lid. Within was a tough chrysalis-case, so tough as to be difficult of incision with a knife. This contained a white grub about a quarter of an inch in length. We placed the remaining cases in some flannel for the winter months, and through the spring waited in vain for sign of life. We were beginning to think our foster nursing had been a failure, when, on July 3rd, two little bees were seen, and a third just emerging from its cradle. They were black with yellow down on legs and underneath the body. They waited some hours by their empty cases, and then took their flight. One by one the others appeared. A clicking noise, like a tiny pair of scissors at work, was heard before the little caps were pushed up by the heads of the bees. All had gone in about four days. The process, however, is being repeated; on July 15th, a bee was again noticed at work, this time having chosen a hanging-pot of dead musk. We tracked it to its quarrying ground in the garden, a rosebush with rather large leaves, and there saw it cut and carry away the needed material, the little clicking noise again being heard. This, of course, cannot be our friend of last year, but one of her children. A second bee seems now in attendance, probably this is the male. We have turned out the musk pot, and found forty-three cases arranged mostly in pairs, placed end to end.—[Mrs.] *F. W. Bell, Rosemont, St. John's, London, S.E.; August, 1897.*



**CONCHOLOGICAL SOCIETY (LONDON BRANCH).**—On July 22nd the Rev. J. W. Horsley, M.A., President of the London Branch of the Conchological Society, gave an interesting and instructive lecture on "Slugs and Snails," at the Newington Free Library, Walworth Road, S.E. To illustrate his remarks, Mr. Horsley exhibited a large number of British and foreign helices, and Mr. J. E. Cooper showed under a microscope the darts and jaws of some of the British snails. In order to encourage the study of our land-shells, Mr. Horsley has presented a collection, which includes nearly all the species of British land and fresh-water mollusca, to the Newington Free Library. The shells are neatly mounted in two wall-cases for easy reference, and are accompanied by a framed synopsis of the species, with a glossary of the names. Other collectors may well follow such a good example.—*J. E. Cooper, Hon. Sec., 93, Southwood Lane, Highgate.*

**CITY OF LONDON ENTOMOLOGICAL AND NATURAL HISTORY SOCIETY.** Meeting held Tuesday, August 3rd, 1897. Exhibits—Mr. Dadd, larvae of *Chrysomela elpenor*, three being in their last skin and two in the last skin but one, taken on Lea Marshes, near Ponder's End, on bedstraw. When exhibited these larvae were feeding on willow herb. He also showed larvae of *Arctia caia*, in second and third skins, bred from dark female with yellow suffused hind wings. Mr. E. Heasler, the result of fourteen days' work in the New Forest, forty-six species of lepidoptera in all, including two *Diphthera orion*, one *Arctia villica* from Lymington Salt Marshes, also larvae of same in fourth and fifth skins. He drew attention to a dark var. of *Aplecta prasina* (*Herbida*), and, as good captures, *Acidalia stramineata*, *A. triginata*, and *A. subsericata*. He also showed the results of breeding *Selenia illuniaria*, var. *Julia*, from eggs of spring brood. Mr. Bate, larvae of *Platysamia cecropia*, given to him when in their second skin by Mr. O. Lindermann. In this skin they are yellow, with black tubercles, each surmounted by five short hairs. In the third skin they have four red tubercles on the first two thoracic segments, the remainder black with blue tips and black hairs. In the fourth skin the four red tubercles remain, and the two rows of seven next the dorsal line and one single tubercle on the eighth abdominal segment are yellow, the remainder being blue. In the fifth skin there are six red tubercles, the remainder as before, except that the yellow ones have only one bristle each instead of five or six, as in the earlier skins.—*H. A. Sauzé.*

**HULL NATURALISTS AT SPURN.**—On Saturday, August 14th, 1897, the members of the Hull Scientific and Field Naturalists' Club spent a pleasant and profitable day at Spurn. Notwithstanding the unsettled state of the weather the previous day a large number of members and friends assembled at Withernsea Station, three conveyances being required to take the party.

At the outset the weather cleared, a bright sun and slight breeze favouring the excursion the whole of the day. On the outward journey a halt was made at the picturesque village of Easington, and Mr. Loten's well-known museum was visited. Mr. Philip Loten conducted the visitors round the collection of stuffed birds, etc. Foremost amongst the rarities were Maqueen's bustard, caught last year, and the green-backed gallinule, of more recent capture. Both these birds were secured in the neighbourhood. Mr. Loten, senr., then exhibited his unique collection of artificial flowers, sprays, etc., which he had constructed entirely from fish-bones and eyes. All of these, veritable works of art, were greatly admired. A walk across the road to Mount Pleasant, and the members were met by Dr. H. B. Hewetson, the President of the Leeds Naturalists' Club, with whom a pleasant half-hour was spent. In his garden were to be seen several objects of antiquarian and geological interest, all found in the neighbourhood. Amongst them was a large boulder of Shap granite, beautifully striated, which, when found by Mr. Cordeaux in 1889, was the farthest point to the south-east at which that particular rock had been noticed. Other varieties of granite, porphyry, gneiss, conglomerate, etc., from both England and Scandinavia, were here heaped together, the specimens having been collected from the beach. Several querns, probably British, of various types, were also shown. These were of especial interest in view of the exhibition of antiquarian objects lately held in the Club's room. Inside, Dr. Hewetson had arranged a large collection of birds, which he had shot in Algeria, the Sahara, and other parts of northern Africa. The most notable and interesting of these were pointed out, and great stress was justly laid on the fact that the colouring of the plumage of the birds was usually in strict accord with the colours of the birds' natural surroundings. Dr. Hewetson also allowed the visitors to examine his collection of fossils, mammalian remains, and antiquities, which had been found in the vicinity, several relics of the ancient Britons being amongst them. On the proposition of Mr. Walker, a hearty vote of thanks was accorded to the Leeds President. The remainder of the day was pleasantly passed away on the narrow tongue of land between Killinsea and Spurn Lighthouse. A walk along this, with the Humber on one side and the North Sea on the other, was an experience long to be remembered. It was literally teeming with life of every form now and then an enormous flock of birds, a number of lizards on the sand or other interesting features made the outing enjoyable. It was a pleasing sight to witness the clumps of sea-holly and the masses of yellow rag-wort, both in full bloom or to observe the quantities of caterpillars of all sorts, notably of the puss-moth, in hundreds, on the bushes and shrubs. The fact was forced upon the members that most of the twigs, bushes, and low plants growing on the sand were armed with thorns. A goodly array of specimens was secured. The geologists found a good hunting-ground amongst the rocks and fossils on the beaches, the botanists and entomologists filled their cases and boxes with material from the higher part of the ground, whilst now and then a dead bird was obtained amongst them was a young cuckoo. One visitor reaped quite a harvest of skulls of birds, cats, dogs, hedgehogs, etc. These were principally found on the Humber side of the land. After tea, a very pleasant drive to

Withernsea terminated a profitable day's outing, which was made the more enjoyable by the excellent waggonette accommodation.—*T. Sheppard, Hon. Sec., 78, Sierburn Street, Hull.*

## METROPOLITAN SCIENTIFIC SOCIETIES.

The following is a list of societies in the London district devoted to natural science, with hours and places of meeting. They may be visited with introduction from a Fellow, Member, or Secretary.

- ANTHROPOLOGICAL INSTITUTE OF GREAT BRITAIN, 3, Hanover Square. Second and fourth Tuesdays at 8.30 p.m., November to June.
- CITY OF LONDON COLLEGE SCIENCE SOCIETY, White Street, Moorfields, E.C. Last Wednesday in each month, October to May, 7.30 p.m.
- CITY OF LONDON ENTOMOLOGICAL AND NATURAL HISTORY SOCIETY, London Institution, Finsbury Circus. First and third Tuesdays, 7.30 p.m.
- CROYDON MICROSCOPICAL AND NATURAL HISTORY CLUB, Public Hall. Third Tuesdays, October to May, 8 p.m.
- DULWICH SCIENTIFIC AND LITERARY ASSOCIATION. Fortnightly meetings. (No information as to place and time.)
- EALING NATURAL SCIENCE AND MICROSCOPICAL SOCIETY, Victoria Hall, Ealing. Second and last Saturdays, October to May.
- ENTOMOLOGICAL SOCIETY, II, Chandos Street, Cavendish Square. First Wednesday, October to June (except January). Third Wednesday, January, February, March and November, 8 p.m.
- GEOLOGISTS' ASSOCIATION, University College, Gower Street. First Friday, 8 p.m., November to July.
- GEOLOGICAL SOCIETY OF LONDON, Burlington House, Piccadilly. Fortnightly, November to June.
- LAMBETH FIELD CLUB AND SCIENTIFIC SOCIETY, St. Mary Newington Schools, Newington Butts, S.E. First Mondays all the year and third Mondays in winter, 8 p.m.
- LINNEAN SOCIETY OF LONDON, Burlington House, Piccadilly. First and third Thursdays at 8 p.m., November to June.
- LONDON AMATEUR SCIENTIFIC SOCIETY, Memorial Hall, Farringdon Street, E.C. Fourth Friday in each month, October to May, 7 p.m.
- MALACOLOGICAL SOCIETY OF LONDON, meets in Linnean Society's Rooms, Burlington House. Second Friday each month, November to June, 8 p.m.
- MINERALOGICAL SOCIETY. Meets in rooms of Geological Society, February 4th, April 14th, June 23rd, November 17th.
- NONPAREIL ENTOMOLOGICAL AND NATURAL HISTORY SOCIETY, 99, Mansfield Street, Kingsland Road, N.E. First and third Thursdays, 8 p.m.
- NORTH LONDON NATURAL HISTORY SOCIETY, North-East London Institution, Dalston Lane (Dalston Station). Second and fourth Thursdays, 7.45 p.m.
- PHARMACEUTICAL SOCIETY OF GREAT BRITAIN, 17, Bloomsbury Square, W.C. Tuesday following first Wednesday of month, 8 p.m.
- QUEKETT MICROSCOPICAL CLUB, 20, Hanover Square. First and third Fridays, 8 p.m.
- ROYAL BOTANIC SOCIETY OF LONDON, Regent's Park. Second and fourth Saturdays at 3.45 p.m.
- ROYAL HORTICULTURAL SOCIETY, 117, Victoria Street, S.W. Second and fourth Tuesdays, except December to February.
- ROYAL METEOROLOGICAL SOCIETY, 22, Great George Street, Westminster. Third Wednesday, November to June, 5 p.m.
- ROYAL MICROSCOPICAL SOCIETY, 20, Hanover Square. Third Wednesdays, October to June, 8 p.m.
- SILBORNE SOCIETY, 20, Hanover Square. First Tuesday and third Thursday, 5.30 p.m.
- SIDCUP LITERARY AND SCIENTIFIC SOCIETY, Public Hall, Sidcup. First and Third Tuesdays, October to May.
- SOUTH LONDON ENTOMOLOGICAL AND NATURAL HISTORY SOCIETY, Hibernia Chambers, London Bridge, S.E. Second and fourth Thursdays, 8 p.m.
- SUTTON SCIENTIFIC AND LITERARY SOCIETY, Public Hall Chambers. Fortnightly. (No information of dates or time.)
- WEST KENT NATURAL HISTORY, MICROSCOPICAL AND PHOTOGRAPHIC SOCIETY. Meets in School for Sons of Missionaries, Blackheath, third Wednesday, in December, fourth Wednesdays in October, November, January, February, March, April, May, 8 p.m.
- ZOOLOGICAL SOCIETY OF LONDON, 3, Hanover Square. 8 p.m., November to August.

## NOTICES OF SOCIETIES.

## THE GEOLOGISTS' ASSOCIATION OF LONDON.

*Excursions and Conductors.*

- Sept. 4.—Whitchurch, Oving, Quainton. A. M. Davies, F.G.S. Baker Street, 9.37 a.m. for Waddesdon Manor.  
 „ 18.—Holmesdale Valley. W. J. Lewis Abbott, F.G.S. Victoria (L. C. and D. R.), 1.30 p.m. for Otford.  
 For particulars of these excursions, apply to Horace W. Monckton, Esq., Secretary for Excursions, 10, King's Bench Walk, Temple, E.C.

## NORTH LONDON NATURAL HISTORY SOCIETY.

- Sept. 2.—“The Microscope.” C. Nicholson, F.E.S.  
 „ 4.—Half-day Excursion to Epping Forest. Leader, The President.  
 „ 16.—“Explanatory Paper on the Order Hymenoptera.” F. B. Jennings.  
 Oct. 7.—Pocket Box Exhibition and Microscopical Evening.  
 „ 21.—Special Meeting to consider the New Rules.  
 „ 30.—Visit to the Natural History Museum, South Kensington. Leader, S. Austin.  
 Nov. 4.—“Through Cornwall and Devon.” J. A. Simes.  
 „ 18.—Debate: “Does scientific study destroy or militate against the æsthetic tastes or sense?” Opened in the affirmative by F. W. Frost; opened in the negative by A. Bacot.  
 Dec. 2.—“Insectivorous Plants.” R. W. Robbins.  
 „ 16.—General Business Meeting—Election of Officers for 1898.

Meetings held at North east London Institute, Hackney Downs Station, at 7.45 p.m.

There will also be a special-family discussion, entitled “The Liparidae,” to be opened by A. Bacot on some date not yet fixed.—*Lawrence J. Tremayne, Hon. Secretary.*

## WOOLWICH POLYTECHNIC NATURAL HISTORY SOCIETY.

*Meetings and Lecturers; Excursions and Conductors.*

- Sept. 4.—Abbey Wood Railway Station, 3 p.m. Knee Hill and lanes—larvæ and mollusca. H. J. Webb.  
 „ 9.—Woolwich Polytechnic. Exhibition by Microscopical Members. W. Scott.  
 „ 11.—Plumstead Railway Station, 2 p.m. Greenhithe—mollusca, etc. E. J. Cunningham.  
 Sept. 18.—Plumstead Church, 3 p.m. Manorway—mollusca, ditch work, etc. J. E. Stacey. (For juvenile members.)  
 „ 23.—Woolwich Polytechnic. “The Moon,” illustrated by lantern views. T. W. Brown.  
 „ 25.—Wickham Lane (north), 3 p.m. Bostal caves—*H. pulchella*, *Cl. rolphii* and *C. acicula*. T. W. Brown.

Meetings, alternate Thursdays, at Polytechnic, William Street, Woolwich, 7.30 p.m.—*H. J. Webb, Hon. Sec., Polytechnic; or 3, Gunning Street, Plumstead.*

## LAMBETH FIELD CLUB AND SCIENTIFIC SOCIETY, St. Mary, Newington, Schools, Newington Butts, S.E. Meetings 8 p.m. Secretary, H. Wilson, 14, Melbourne Square, Brixton, S.W.

*Meetings and Lecturers; Excursions and Conductors.*

- Sept. 18.—Geological Outing to Gravs. A. Ramsay.  
 „ 20.—Meeting, “Crystals.” J. J. Denton.  
 Oct. 4.—“The Story of Algal.” J. J. Hall.  
 „ 11.—Annual Exhibition and *Soirée*.  
 „ 18.—“Reflex Action of Muscles and Nerves.” J. S. Clough.  
 Nov. 1.—“Prehistoric Man.” G. F. Lawrence.  
 „ 15.—“Photo micrographs of Insect Anatomy,” with lantern illustrations. F. Clark.  
 „ 20.—“Visit to British Museum, Prehistoric Section  
 Dec. 6.—“Fossils, and the ways in which they are found preserved.” Dr. H. F. Parsons.  
 „ 11.—“Visit to Natural History Museum, Shell Gallery.  
 „ 13.—Photographic Demonstration. C. J. Stokes.

## NOTTINGHAM NATURAL SCIENCE RAMBLING CLUB.

*Geological Section.*—Leader, J. Shipman, F.G.S.

- Sept. 11.—Hucknall Torkard and Long Hills. Meet Midland Station, 1.30 p. m.  
*Botanical Section.*—Leader, W. Stafford.  
 Sep. 18.—Radcliffe and environs. Meet G.N.R. Station, 1.45 p.m.  
 Oct. 16.—Annual Meeting, Rambling Club, Natural Science Laboratory, University College, Nottingham, 4 p.m. Tea, *soirée* and exhibition of collections made during season. *W. Bickerton, Hon. Sec., 187, Noel Street, Nottingham.*

## HULL SCIENTIFIC AND FIELD NATURALISTS' CLUB.

- Sept. 1.—Microscopical Evening; members; 8 p.m.  
 „ 4.—Leconfield; leave Paragon Station 1.10 p.m., train for Arram. Single fare, 1s., return from Beverley.

- Sept. 11.—Hessle; leave Hull 2.25 p.m. train. Single fare, 5d.; walk back *via* Humber Bank and Newington.  
 „ 15.—“Diatoms.” R. H. Phillip.  
 „ 18.—Cleethorpes, for Clew; leave Hull 1.45 p.m., boat. Return fare, 1s.  
 „ 25.—Endyke Lane; meet at Newland, 3 p.m.  
 „ 29.—Annual Meeting.  
*T. Sheppard, Hon. Sec., 72, Prospect Street, Hull.*

## NOTICES TO CORRESPONDENTS.

TO CORRESPONDENTS AND EXCHANGERS.—SCIENCE-GOSSIP is published on the 25th of each month. All notes or other communications should reach us not later than the 18th of the month for insertion in the following number. No communications can be inserted or noticed without full name and address of writer. Notices of changes of address admitted free.

NOTICE.—Contributors are requested to strictly observe the following rules. All contributions must be *clearly* written on one side of the paper only. Words intended to be printed in *italics* should be marked under with a single line. Generic names must be given in full, excepting where used immediately before. Capitals may only be used for generic, and not specific names. Scientific names and names of places to be written in round hand.

THE Editor is not responsible for unused MSS., neither can he undertake to return them, unless accompanied with stamps for return postage.

SUBSCRIPTIONS.—Subscriptions to SCIENCE-GOSSIP, at the rate of 6s. 6d. for twelve months (including postage), should be remitted to the Proprietors, 86, St. Martin's Lane, London, W.C.

THE Editor will be pleased to answer questions and name specimens through the Correspondence column of the magazine. Specimens, in good condition, of not more than three species to be sent at one time, *carriage paid*. Duplicates only to be sent, which will not be returned. The specimens must have identifying numbers attached, together with locality, date and particulars of capture.

ALL editorial communications, books or instruments for review, specimens for illustration, etc. to be addressed to JOHN T. CARRINGTON, 1, Northumberland Avenue, London, W.C.

## EXCHANGES.

NOTICE.—Exchanges extending to thirty words (including name and address) admitted free, but additional words must be prepaid at the rate of threepence for every seven words or less.

WANTED, “Life Lore,” vol. 1., bound or unbound; also “London Catalogue: British Plants,” 8th edition.—W. W. Cullwick, Aldine Villa, Oaklands Road, Wolverhampton.

WANTED, plants or seeds of *Gentiana germanica*, *G. praecox*, *Bidens cernua* var. *radiata*, *Aster tripolium* var. *discoideus*, in exchange for other specimens, mounted preparations, etc.—E. R. Saunders, Newnham College, Cambridge.

OFFERED, clutches of black-headed, common and lesser black-backed gull, fulmar, gannet, guillemot, and numerous other species. *Desiderata*, clutches not in collection.—W. Hy. Heathcote, F.L.S., Preston.

DUPLICATES.—*Actæon*, *sibylla*, *paphia*, *adippe*, *galatea*, *semele*, *lucina*, *agon*, *minima*, *neustria*, *mesomelia*, *dispar*, *cytherea*, *pyrmitidea*, etc.; also 500 species of Coleoptera. *Desiderata*, local macros, pupae, or stamps.—A. J. Ford, Rosemount, Hannington Road, Bournemouth.

## NOTICE TO READERS AND OTHERS.

A CUTTINGS Agency has from time to time, latterly, sent cuttings from British newspapers of paragraphs signed “Science-Gossip,” which have not originally appeared in this Journal. One, for instance, referred to an illustrated account of a “rotating shirt-front.” Our regular readers will know that such paragraphs did not appear in SCIENCE-GOSSIP. The cuttings seem to have been taken from some American papers at second-hand.

## DARWIN AT SHREWSBURY.

BY JOHN T. CARRINGTON.

THE history of the Darwin Statue at Shrewsbury is rather a long story, and not altogether creditable to the town which was honoured by his birth. The narrowness of some of its townsmen, and we may say their ignorance of Darwin's great work, was sufficient for a considerable time to crush the proposals to place within the borough a public memorial to his memory. Letters and articles appeared in the local newspapers advocating the project, but the influence of those who knew that "Darwin said we were all descended from apes" was too strong.

It was not until January, 1894, that a public meeting was called to discuss the subject, which led to a second meeting being held in the following May, when the leading lay and clerical inhabitants gave their support. A committee was then formed to obtain subscriptions, and several large sums were promised. No real heart seemed to be in the work, for it dragged along for a couple of years until January, 1895, when no more than £400 had been raised. Subsequently a public meeting was held to pay for any statue suitable to the memory of so great a citizen.

It was then that the Shropshire Horticultural Society, mindful of Darwin's great services to their studies, came to the rescue. The committee of that society resolved to bear the whole cost of a bronze statue to Charles Robert Darwin, which was estimated to cost £1,000. The next wise

thing on the part of that patriotic committee was to commission a native of Shrewsbury, Mr. Horace Montford, the well-known London sculptor, to execute the work. He is, as all artists know, the Curator of the Sculpture Schools of the Royal Academy.

Mr. Montford has been highly successful in his portrait of the eminent philosopher. Several persons of consequence who knew Mr. Darwin in life

assisted with suggestions as to pose and features, not the least among these being Darwin's own son, Professor Francis Darwin, and other members of the family. The result has been most gratifying, and will perpetuate the likeness of one of the greatest men the world has produced.

The general plan of the statue is the representation of its subject as he appeared in the privacy of his study at the picturesque little village of Down, among the Kentish hills. The face shows the powerful intellect it masked, the features are admirably drawn

with the pleasing expression of gentleness and force so marked in the original. Surrounded by books and papers in orderly confusion, he sits in a massive chair, embellished by ornamental work representing his favourite studies. On one side are corals, on the other side are orchids with a bee carrying on its work of fertilizing the flowers, the panel at the back of the chair is filled with barnacles. It is needless to remind our readers how the greatest of naturalists investigated

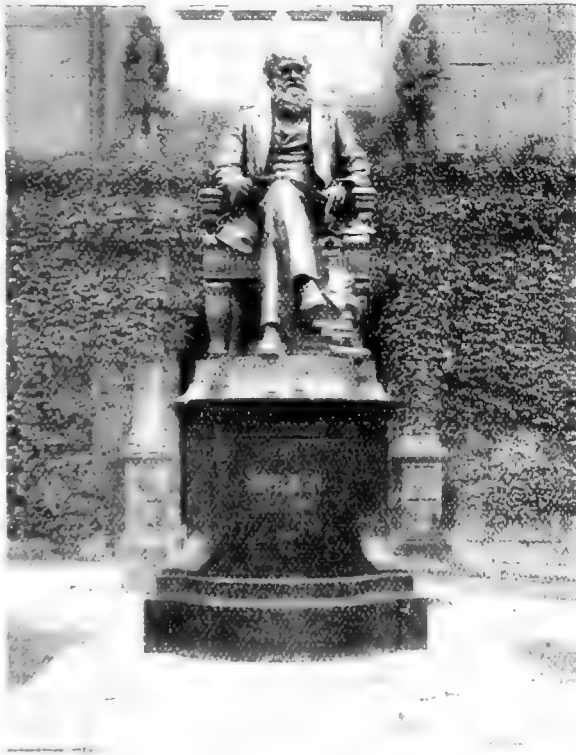

Photo. by

[Naunton, Shrewsbury.]

THE DARWIN STATUE AT SHREWSBURY.



and propounded epoch-making theories with regard to all those subjects.

The statue stands upon a site immediately in front of the Free Library of Shrewsbury, which occupies the building where Darwin went to school. It rests upon a block of polished Labrador granite four feet six inches in height. This pedestal is in four pieces, which collectively weigh about seven tons. That in turn rests upon a base of Devonshire granite; the total height being about twelve feet six inches. On the centre of the pedestal is the one word, "Darwin," at the sides the dates 1809-1882, while at the back is modestly inscribed, "Presented by the Shropshire Horticultural Society, 1897."

If Shrewsbury neglected its great townsman's memory until a private society had to show the town what was its duty, it made some amends at the ceremony of unveiling, which took place on August 10th. A great and influential company assembled in honour of the event. Lord Kenyon, in handing over the statue from the society who gave it to the Mayor, as representing the town which will protect it, reminded the company assembled that they were in the town which saw Darwin's birth, were under the shadow of the school wherein he studied, and that the statue was the gift of a society devoted to horticulture—a science he dearly loved. At the public luncheon which followed the ceremony, the eulogy of Charles Robert Darwin was unstinted; among the speakers being Sir Joseph D. Hooker, who proposed the memory of him whom they had come to honour. As Sir Joseph's words refreshen our knowledge of Darwin's amiable character, we give the substance of his speech on the occasion.

After introductory remarks and saying how little he could add to what had already been written in the admirable "Life of Darwin," Sir Joseph Hooker asked those present

"to look back in their imagination to just sixty years ago and let him tell them of the genesis of the affection and reverence which he cherished for the memory of Charles Darwin. It was in 1838, or early in 1839, that he first knew of him through receiving from an old friend of his (Sir Joseph's) father, the loan of some sheets of the 'Records of a Naturalist during the Voyage of the *Beagle*,' which classical work was then passing through the press. Sir Joseph was at the time himself hurrying through his studies at the University of Glasgow, in order that he might accompany, as a naturalist, Captain (afterwards Sir James) Ross, in his projected voyage to the Antarctic regions. Being engaged with hospital duties, he had little time to devote to the precious sheets, and so he slept with them under his pillow in order that he might read them in the interval between dawn and dressing. This he did with fascination, but, he must add, with despair of ever following, at however great a distance, in the footsteps of so admirable an observer and reasoner. A copy of the 'Records of a Naturalist' was sent to him as a parting gift as he was on the eve of leaving England; but meanwhile he had once met the author, having been casually introduced to him

in the streets of London by a shipmate who had sailed with him in the *Beagle*.

"Very shortly after his return from the Antarctic voyage in 1843, he received from Darwin a cordial invitation to visit him at his 'inaccessible home,' as he used to call it, at Down, adding that he had much to ask him about, in botanical matters especially; and, as he afterwards found, Darwin especially wished that he should publish some of the botanical results of the voyage. This 'inaccessible home,' destined to become the Mecca of so many a scientific and literary pilgrim in after years, was then ten miles from a railway station. Sir Joseph said he should never forget the frank and joyous reception that met him on his first visit to Down, damped though it was by finding his friend's health so impaired. They had much to talk over, having visited in many cases the same countries during their respective voyages—the Cape of Good Hope, Rio de Janeiro, St. Helena, Tasmania, New South Wales, New Zealand, &c., so that they felt like fellow-voyagers, forgetting the eight years that had elapsed between the dates of their respective cruises. It was, however, in the study at Down that their intimacy commenced and ripened. On the morning after his arrival on his very first visit, Darwin asked him to accompany him to his sanctum for the purpose of his giving Mr. Darwin some botanical information, the great naturalist being especially engaged on the geographical distribution of animals and plants. The following was a sample of how the day was passed on this and many subsequent visits.

"Mr. Darwin had always a long list of queries to put to him, sometimes collated months beforehand, the answers to which were distributed on slips of paper amongst a marvellous number of pockets, bags and portfolios that hung on the wall or occupied racks by the fireside. This 'pumping,' as Darwin called it, went on for twenty minutes or half-an-hour, after which he stated that he was incapable of further mental exertion, and that he must rest till the time for his mid-day walk. They might ask him what struck him most forcibly about these exercises of his intellect, and putting aside the marvellous amount of knowledge which he gained. They were Darwin's indomitable perseverance under bodily suffering; his command of all the available sources of knowledge in any given object of research; his vivid and strong grasp of the most difficult subjects, and his power of turning to account the waste observations and even the blunders of his predecessors and contemporaries; which power Sir Joseph's friend, Sir James Paget, once told him was, he thought, one of the most striking of the many evidences of Darwin's genius. It is 'dogged that does it,' was a favourite expression with him, and so dogged was he that he had cited his very illness as being to his advantage, congratulating himself, for instance, on sleepless nights that allowed him to read off his continuous observations on the movements of his beloved plants. Such was his association with Darwin for forty years, during all which time he was his guide, philosopher and friend. It only remained for him to join with them in rejoicing over the fact that the admirable likeness of his old friend, which the President had unveiled that day, had been obtained by the efforts of horticulturists, and when he considered how much scientific horticulture owed to Darwin, this was as it should be; moreover, he felt well-assured that could Darwin know that that tribute to his memory was, by those special efforts, placed in his birthplace, amongst the loved scenes



of his early youth, he would regard it as the most prized of all the honours that had been or could be bestowed upon him."

In replying upon behalf of his father's memory and for the family, Mr. W. E. Darwin, after some kindly remarks about the association of Sir Joseph Hooker and his father, said :

"As for the statue, all would feel that it was a noble and lasting monument to what science had done for mankind, and one worthy of a life devoted purely and simply to the study of the mysteries of nature. The statue in the South Kensington Museum was a very high honour to Darwin, and that was raised by subscriptions throughout the civilized world; but he could not help thinking that the statue unveiled that day in some respects was a higher honour still. It showed a deeper sense of the value of Charles Darwin. As regards Darwin himself, he was very human, as all who had read his life knew. He did not search after fame or honour, but when it came to him he received it with unfeigned delight. Nothing would have given him truer pleasure than to know that the Horticultural Society had erected a statue to him in front of his old school and in his own town. To the end of his life he loved Shrewsbury, and he also loved his old school, in spite of the laughing horror he had for all classical training. He used to say that this school training was utterly lost on him in every way, but whether he was right or wrong the speaker did not know. There was one characteristic which he should like to mention, and that was Darwin's immense sympathy with the struggles of all young students or men interested in science, and nothing would have given him greater satisfaction than to think that that statue had acted as a beacon to some youth

anxious to make science his career in the world. It was curious to think that probably the only scientific training he had as a youth was a smattering of chemistry that he had from his brother Erasmus, which earned for him the nickname of 'Gas' in the school. He was called before the great Dr. Butler and reprimanded as a *poco-curante*; but his life's work had had a great deal to do in sweeping away or diminishing the very mediæval form of education that existed in his day. As regards the members of the family and their sense of gratitude, they could understand how difficult it was for him to adequately express all he felt on that occasion, but he would say that the statue seemed quite admirable. The figure gave Darwin's alertness, and the easy, natural way in which he used to sit, with none of the professor about it."

Professor G. H. Darwin also spoke upon memories conveyed to him by his father of the old Shrewsbury schooldays, confirming the horror of the philosopher for dry-as-dust education by classics alone; but he added that his father always looked back upon his schooldays with affection. He agreed with his brother upon the admirable likeness of his father produced by Mr. Montford. When, however, he and his brother saw the statue in the clay they felt that the hands were incorrect. It was arranged that one of them should provide the model for the hands, and it happened that Professor G. H. Darwin's hands were chosen. They thus appear exactly modelled in the statue, which fact adds a point of great interest to the portrait.

## FLOWERING OF DEAD-NETTLE.

By C. E. BRITTON.

WHEN reading Mr. Meehan's remarks on the flowers and flowering of that form of *Lamium purpuraceum* known as *L. incisum* in America (*ibid.* p. 105), I was reminded of a paper entitled "Studies of Flowers," and communicated to the Lubbock Field Club during September, 1894. In this paper I treated of the flowers and fertilization of various British plants, and, among others, of the flowers of the red dead-nettles, more especially *Lamium angustifolium* and *L. incisum*, the latter otherwise known under its synonyms, *L. hybridum* and *L. dumetorum*. I have looked up the MS. of the paper and venture to send the following notes on the flowers of *L. incisum*, which I have extracted from it as read before the Field Club on that occasion.

"The cut-leaved red dead-nettle is one of those interesting plants that is apparently in a state of evolution between a variety and a true species. The old botanists ranked it as a variety of the common (red) dead-nettle, from which it differs chiefly by its deeply cut leaves and the corolla tube

being about as long as the calyx. In the 'Students' Flora' Hooker regards it as a sub-species, but most field botanists, I believe, are inclined to rank it as a species. I have never seen any reference to the cleistogamic<sup>(1)</sup> flowers of this species, but during cold, unsettled weather, such as we experience in the early part of the year, cleistogamic flowers do occur. I first met with the plant about Orpington, in Kent, during the early part of March last. Being previously unacquainted with the plant, I gathered a good quantity of it, and also of the common red dead-nettle for the purpose of comparing the two. I noticed at the time that though the cut-leaved red dead-nettle was bearing immature fruit, expanded flowers were very scarce, or absent, though flower-buds were numerous.

(1) Cleistogamy is a peculiar dimorphism in flowers of some plants. It is present when in addition to the ordinary fully-developed flowers there are others in which the development is arrested in the bud, but which are fertile and produce abundance of seed. Where cleistogamy occurs, the flowers are small, minus petals, nectaries, or perfume. They are always fertile and self-fertilized. This condition has been observed in at least sixty genera of widely different orders, generally dicotyledonous plants. — L. S. G.

The plants, when brought home, were placed in water and kept under observation for several days, during which many flowers expanded. When I came to closely examine these recently-opened flowers I noticed a rather singular fact. These opened flowers were lying quite loose in the calyx-tube, that is to say, the corolla was not connected at the base with the receptacle. What had happened was evidently this. The flowers were cleistogamic, the stigma had been pollinated, and fertilization had followed, after which the developing and swelling ovary had effected the separation of the corolla from the receptacle, and by its own growth had pushed the corolla up the calyx-tube. That this view was correct was confirmed by the fact that in many flowers the corolla did not expand, but was separated at its base from the receptacle, and elevated by the ovary, which was now developing into the fruit. About Oxshott, in Surrey, Mr. Turner and I met with this same plant on March 23rd last. Though the species was plentiful, we failed to find the ordinary opened flowers, these being of the cleistogamic type.

"There are one or two problems connected with the occurrence of these closed self-fertile flowers, on the cut-leaved red dead-nettle, which is so closely allied to the common red dead-nettle; and I shall refer to these further on.

"In the foregoing part of this paper, when treating of the cleistogamic flowers of the cut-leaved red dead-nettle, I mentioned there were certain problems connected with these flowers that deserved further attention. When two closely-allied plants grow in similar situations and flower about the same period, there must be a certain amount of competition between them. Should one of the species, however, flower slightly before the other, as in the cut-leaved dead-nettle, and should these flowers prove fertile, and also if the plant continues in flower as long as its competitor, it seems likely that this species will have a certain advantage over its ally. Against this view, we must balance the fact that, of the two, the cut-leaved dead-nettle is the less common plant."

With regard to the first paragraph in Mr. Meehan's article, on page 105, whilst there seems to be much evidence to support the idea that plants have not a uniform behaviour in every place, and, with regard further to the implied query as to *Lamium incisum* in Europe, my rough notes, made over three years ago, seem to show that the fertilization in bud of the flowers of this species is not a new departure in the New World, and that the same thing occurs in Europe.

189, Beresford Street, Camberwell, London, S.E.;  
September 9th, 1897.

## BOTANICAL RAMBLES ROUND EDINBURGH.

BY R. DICKSON-BRYSON, B.A., F.P.S.

THE wealth of hill and glen and marsh encircling this fair metropolis of the north affords a happy hunting ground to the botanical enthusiast. Here his diligence will be amply rewarded; for plant life is profuse everywhere, and with few exceptions easily procurable. During the three months of summer I collected considerably over three hundred specimens, representing some fifty natural orders. This is not exhaustive, for I had not the time to devote to the more familiar members of the kingdom; the researches were chiefly confined to the more rare and unnoticed plants. The hills to the south and south-east of the city; Duddingston Loch and its extensive marsh; Craigmillar Castle and the adjoining woods; Colinton and its romantic and well-wooded glens; and, occasionally, the Pentlands, were visited.

Scarcely a mile south-east from the city stand out in bold pre-eminence those huge, rib-like precipitous rocks, known locally as "Samson's Ribs." Here, among the cliffs, a few rare plants luxuriate. Chief among them is the *Lychnis viscaria*, or sticky campion, with its dense panicle-like heads of bright pink corollas and alternate leaves of dark

glossy green. A little further round towards the east of the cliff, and on a grassy slope, the sandwort, *Arenaria verna*, may be found; it is not very common. Lying low in the more shaded parts, several species of the *Viola*, or pansy, may be seen: the *V. tricolor*, *V. canina* and *V. odorata*. The tri-coloured species is very common, and is perhaps the prettiest. No one can mistake its pretty yellow, white and purple petals standing out from the mass of green. The popular appellation, "pansy," is probably derived from the French phrase, "*Pensez à moi*." Shakespeare makes Ophelia, in *Hamlet*, say, "Pray you, love, remember, there's pansies, that's for thoughts." The rock-rose, *Helianthemum vulgare*, is plentiful, and its bright yellow corollas delight the eye everywhere. To the untutored eye the rock-rose is apt to be confounded with the cinque-foil, or *Potentilla reptans*, here in lavish profusion; but it may be readily distinguished by its quinate leaf. The silver weed, *P. anserina*, is not quite so frequent. The tall *Echium vulgare*, or bugloss, with its beautiful spikes of mingled blue and purple, is, if a little care be exercised, easily procurable. The

bugloss seems to prefer isolated situations. As we move a little further round in the direction of the village of Duddingston, we meet with its only British ally, the *E. plantagineum*, and which, if not quite so conspicuous, is at all events as pretty. It is low and bushy, and inclined to congregate, thus offering a marked contrast to its more stately ally. I sought to procure a specimen of this latter, and in my wanderings unwittingly intruded myself on a wasps' nest, and for the moment deemed it more prudent to beat a hasty retreat. I ultimately procured a good specimen, which now graces my herbarium. Here in the more inaccessible parts, several species of the geranium abound,—the more common being *Geranium sanguineum*, with its soft purple flowers; *G. robertianum*, or herb-robert; and *G. molle*; the *G. dissectum* is less common, and the *Erodium cicutarium* is found everywhere in gravelly situations. Almost everybody knows the pretty whin bush, *Ulex europæus*, which blooms here at all seasons, though its principal flowering month is May. The story is told of Linnæus, that when he first visited this country he was so enraptured at the sight of a furze-covered heath that he fell on his knees and wept in admiration. A heath decked with the bright golden-hue of this shrub is certainly very beautiful. There is another indigenous species found here, but extremely rare—the *Ulex nanus*. Some botanists conclude this to be a mere variety; but if we consider its humbler growth, more diverse habits, and its diminutive flowers, and add to these the unvarying regularity of the assumed specific characters of the two, we can hardly give assent to the conclusion.

Our next step is to explore the old wall running alongside of the railway embankment. We descend the slope leading thereto, and here a few plants of interest obtain. The *Ranunculus lingua* and the *Sedum acre* are common, and a solitary specimen of the rare *Caulalis nodosa* is interesting. This is the first living specimen of this species I have seen. The old wall abounds in that locally rare member of the ferns, *Asplenium ruta-muraria*, or wall rue, with its densely sombre, glossy fronds. That pretty little creeper, *Linaria cymbalaria*, now presents itself. Its gaping corollas of pale lavender, and lobed, reniform, glaucous leaf, enliven the monotony of ascending club-moss. At the base of the wall *Nepeta pycnantha* luxuriates. The *Matricaria inodora* and *Chrysanthemum leucanthemum* grow in mingled plenty. The *Centaurea cyanus* is frequent, and the *Papa er rh eas* and *Melica sylvestris* abound. A profusion of *Veronica chamaedrys*, *V. beccabunga* and *Myrtis sylvestris* heighten the gaiety of the scene. Here *Lamium album* and *L. purpureum* attain a high degree of perfection. The *Epilobium montanum*, *Apium rotiflorum*, *Empetrum saxifraga*, *Arenaria ciliata*, *Asteris squarrosus* *Silene pratensis*,

*Myrrhis odorata*, *Conium maculatum*, *Galium cruciata*, and *G. mollugo* are also found with *Rubia feregrina*.

The marsh surrounding Duddingston Loch abounds in palustrine plants. The chief ornament of the marsh is the buckbean, *Menyanthes trifoliata*. Their flower-tufts of white rising from their emerald-green bed, and mingling with the vivid pink of ragged-robin—both in great abundance—render the scene truly striking. The delicacy of *Menyanthes*, it may be observed, is such that it yields readily to the slightest cold. It was in the early morning I found them, and on returning in the evening, about an hour after sundown, I was dismayed to find that the fall in temperature had entirely destroyed them. The cuckoo flower, *Cardamine pratense*, is plentiful, and its ally, *C. amara*, is to be found, but it is rather scarce. *C. amara* has a general resemblance to *C. pratense*, but is readily distinguished from it by the yellowish tint of its petals, and by the broad, deeply toothed leaflets of the upper leaves; while the upper leaves of the *C. pratense* are somewhat feather-shaped, and similar to those of *Hottonia palustris*. Several species of *Ranunculus* are frequent, including *R. sceleratus*, *R. ficaria*, *R. lingua*, and the beautiful *Caltha palustris*, spreading its bright golden petals towards the extremity of its stem, which attains to the height of twelve or eighteen inches, adorns the water's edge. There is another species, *C. radicans*, which is furnished with triangular instead of reniform leaves, and smaller flowers than the former; it is not very common, and requires some diligent search for its discovery. I have found only one specimen. *Nasturtium officinale*, *Lychnis vespertina*, *L. diurna*, *Silene cucubalus*, and *S. flos-cuculi* are numerous. The daffodil, *Narcissus pseudo-narcissus*, and yellow iris, *Iris pseudocorus*, when viewed in such profusion as here, have an undoubted claim to be classed among the more beautiful of our field flowers. There are several specimens of the water-plantain, *Alisma plantago*, and of the *Epilobium angustifolium* and *E. hirsutum*.

The spotted orchis, *Orchis maculata*, is not by any means uncommon; it loves the shady places of the marsh. *Habenaria bifolia* is also found here. Almost the entire surface of the lake is covered with duckweed, *Lemna minor*, and the effect is pleasing. The flowers arise from the floating leaves, and the roots are entirely in the water, their extremities being provided with a little sheath, which is a beautiful microscopic object. *Geum urbanum*, *G. rivale*, *Spiraea ulmaria*, *Lathyrus palustris*, *Vicia hirsuta* and *Lotus corniculatus* are found scattered all over.

It would be impossible here to give a complete list of the plants to be found in the immediate vicinity of the city, but it is hoped those given may be sufficient as an evidence of Flora's lavish and varied gifts to these parts.

## COLOURATION AND ZONULATION IN TACHEA.

By A. E. BOYCOTT. (1)

EVERYONE is familiar with the brightly-coloured snails—red, yellow, brown, some marked with bands, some plain—which abound in almost every hedge-bank in rainy weather. They are known as *Tachea memoralis*, L., and *T. hortensis*, Mull., and form the genus *Tachea* of the great group *Helix*. I propose to call attention to a few points connected with the variation in colouring and banding to which these snails are subject in Herefordshire, dealing with them as grouped into different batches by differences in either the time or the place of their origin. There is one case of especial interest which, by the kindness of Mr. A. C. de Boinville, of Plymouth, I am enabled to deal with. This gentleman collected numerous specimens of *Tachea* in the immediate neighbourhood of Hereford some fifty years ago (mostly in 1843), and it seems worth while to see how far this collection which—amounting to some 730 specimens—he has been good enough to place in my hands corresponds with and differs from the same species found around Hereford at the present day. There is further to be considered how far these species differ in various localities, separated by short or long distances, especially considering differences in geological formation. At present I only bring before you a comparison of the specimens from the large quarries of Wenlock limestone in Dormington Wood, near Stoke Edith, with those from various stations in the Old Red Sandstone.

It is obvious that to obtain exact results, every specimen (personally, I confine myself to full-grown specimens, judged by the peristome) to be found in the locality under examination must be collected and considered. Every shell of one of these catches is carefully examined as to its colour, banding, size and shape, weight, thickness, and any other peculiarities. I have thus worked over about 2,500 Herefordshire *Tachea*, but hope to do many more in the future; the more numerous the examples, the more nearly will our conclusions, percentages and averages approximate to the truth. There is no doubt that this condition, which I have prescribed for my own collecting, has not been rigorously adhered to in the case of the De Boinville collections, but from what Mr. de Boinville has told me as to his methods, I do not think that the figures are so far from representing the truth as might be suspected. At the same time, I claim for them none of the accuracy which I think is to be found in the other cases I am bring-

ing before you; and it is plain that collections consisting of the striking specimens only are useless for the purpose under consideration.

The localities I consider to day are five in number: (1) Dormington Quarries (88 specimens), in District 3, on the Silurian limestone; December, 1893, and January, 1894. (2) De Boinville collection (737), from Districts 7 N and 7 S, on the Old Red Sandstone; circa 1843. (3) Moreton-on-Lugg (540), District 7 N, on the Old Red Sandstone; July, 1896. (4) The railway bank, near Hunderton (216), District 7 S, on the Old Red Sandstone; April, 1895. (5) Broomy Hill, near Hereford (308), District 7 N, on the Old Red Sandstone; April, 1895.

Firstly, as to the proportion between these species. The superficial distinction in the colour of the peristome (black or brown in *T. nemoralis*, white or nearly so in *T. hortensis*) seems to hold good, or at any rate to be verified, in the cases which I have examined by the speculum in Herefordshire. I have not seen a local *nemoralis* with a white lip, and the form *bimarginata*, Picard, is uncommon. Of all the 1889 specimens here considered, 55 per cent. are *nemoralis* and 45 per cent. *hortensis*. Dormington Quarries have a remarkably low percentage (9) of *hortensis*. For further details see the appended Table I.

Secondly, to consider the variation in colour. In *T. nemoralis* there are four main colour types in Herefordshire, as distinguished in the main by their ground colour. These are:

(a) var. *castanea*, Moq., of a brown of varying depth; the best marked specimens are of a very fine rich dark brown, with a blue-purple shade inside and a well-marked yellow rim adjoining the peristome externally.

(b) var. *libellula*, Risso., of a yellow colour.

(c) var. *rubella*, Moq., of a red colour.

(d) var. "*mista*." I have ventured to apply this name, for my own use, to a form which is very common in Herefordshire. It is typically heavily banded with dark bands, and the ground-colour is of no very bright or definite colour. It is really—as has been done in some of the late tables—to be classified under *rubella*. There is no doubt that as the bands increase in number and depth of colour the red ground-colour decreases in intensity. The interesting theoretical conclusion derived from this and similar facts, viz., that the bands are areas of concentrated ground-colour, need not here be further pressed. The term *rubella* by this division becomes practically restricted to specimens (1) with light, often reddish bands; and (2) to those with

(1) Read before the Woolhope Naturalists' Field Club, at the meeting held August 27th, 1897, at Bewdley.

the band-formulae 00000, 00300, 00345, and so on. The form *libellula* may be subdivided in the same way, but reduction in an already pale yellow is not very noticeable. In all the *nemorialis* considered, *castanea*=10 per cent., *libellula*=20, *rubella*=28, *mista*=42. Some of the more noticeable points are the preponderance of *castanea* (22 per cent.) from Dormington Quarries, and the high percentage of *libellula* at Moreton (31), and in the De Boinville collection (36). The very low (7.5 per cent.) number for *rubella*, from Moreton, is compensated for by the high percentage (56) of *mista*, so that the total *mista* and *rubella* is not very far from an average. For further details see Table I.

In *Tachea hortensis* the lack of variation in this

but the great majority are in a border class of their own, and to make a fresh group for them would only double the difficulty by having two boundaries instead of one. The colour varies considerably on different parts of the same shell. Reduction of ground-colour here too appears to follow strong banding; the fewer the bands the deeper the ground-colour in *lutea*, and hence a heavily-banded *lutea* with a bright-yellow ground is uncommon; in true *alba* the paling of the ground-colour is due to something else.

(d) var. *arenicola*, Macgill (8 per cent.), with transparent bands. Of this there are two fairly distinct forms, the one with an opaque, the other with a translucent ground; the latter are, of course, the

TABLE I, SHOWING THE PERCENTAGE OCCURRENCE OF THE TWO SPECIES OF TACHEA, OF THEIR VARIOUS COLOUR FORMS, AND OF UNICOLOROUS AND BANDED SPECIMENS.

	LOCALITY.						Average.
	(1) Dormington Quarry, Dec., 1895, and Jan., 1894.	(2) De Boinville, 1843, circa.	(3) Moreton, July, 1896.	(4) Railway Bank, Hunderton, April, 1895.	(5) Broomy Hill, April, 1895.	4 and 5 combined.	
No. of specimens ..	88	737	540	216	308	524	
<i>T. nemoralis</i> ..	90.9	74.5	83.3	44.4	27.6	36	54.68
var. <i>castanea</i> ..	22.2	11.3	5.1	6.2	7.1	4.65	10.38
unicolor ..	100	17.7	100	66.7	100	83.35	76.88
fasciated ..	0	82.3	0	33.3	0	16.65	23.12
var. <i>libellula</i> ..	13.6	36.1	30.9	14.6	15.3	14.95	20.10
unicolor ..	18.2	7.8	0	0	0	0	5.2
fasciated ..	81.8	92.2	100	100	100	100	94.8
var. <i>rubella</i> ..	34.6	38.2	7.5	33.3	25.9	29.6	27.90
unicolor ..	10.7	10.9	2.9	22.6	13.6	18.1	12.14
fasciated ..	89.3	89.1	97.1	77.4	86.4	81.9	87.86
var. <i>mista</i> ..	29.6	14.4	56.4	46.9	51.7	49.3	41.62
var. <i>mista</i> and <i>rubella</i> ..	64.2	52.6	64.0	79.2	77.6	78.4	69.52
unicolor ..	3.1	8.0	0.35	9.2	4.5	6.85	5.03
fasciated ..	96.9	92.0	99.65	90.8	95.5	93.15	94.97
Total unicolor ..	28.4	8.7	5.3	11.5	10.6	11.05	12.90
Total fasciated ..	71.6	91.3	94.7	88.5	89.4	88.95	87.09
<i>T. hortensis</i> ..	9.1	25.5	16.7	55.6	72.4	64	45.32
var. <i>alba</i> unicolor ..	0	1.6	1.1	—	1.4	0.7	0.82
var. <i>lutea</i> unicolor ..	28.6	15.4	85.5	43.3	33.6	38.45	40.28
fasciata ..	71.4	50.5	11.1	54.2	61.9	58.05	49.82
var. <i>arenicola</i> ..	0	30.8	2.2	2.5	3.1	2.8	7.72
var. <i>fusca</i> unicolor ..	—	1.6	—	—	—	—	0.32
Total unicolor ..	28.6	18.6	86.7	43.3	35.0	39.15	42.44
Total fasciated ..	71.4	81.4	13.3	56.7	65.0	60.85	57.56

neighbourhood is still more marked than it is in *T. nemoralis*. Here again I can distinguish four main types

(a) var. *alba unicolor* (0.8 per cent.): one must avoid reckoning pale *lutea* under this head, though the distinction is really not one of any very great importance

(b) var. *lutea unicolor* (41 per cent.) varies a great deal in intensity of colouring

(c) var. *fasciata* (50 per cent.) not quite the same as Meuke's *fasciata*. I apply this term to white or yellow specimens possessed of bands. I have quite failed to distinguish *alba* from *lutea fasciata*, extreme forms occur (more commonly in *alba*) fairly frequently, and are easy enough to deal with.

*arenicola* form of thin translucent *lutea* or *alba*. A tinge of brown in the bands—which always seem to be pigmented transparencies—places the specimens in the *fasciata* group.

A fifth form has occurred—*fusca*, Poiret—to the extent of four specimens in the county: three in the De Boinville collection, and one from Breniton (District 7N), which last is not reckoned in this paper. The explanation of the lack of variation probably lies in something beyond the geological monotony, as a much more extensive range of colour-forms occurs in other apparently equally monotonous Old Red Sandstone districts.

The De Boinville collection is remarkable for a very high percentage (31) of *arenicola*, while at

Moreton *lutea* goes up to 85 and *fasciata* down to 11 per cent. For details see Table I.

We have next to consider the question of the presence or absence of bands. Altogether, in *T. nemoralis*, about 13 per cent. are unicolorous; in *T. hortensis*, about 42 per cent. Dormington Quarries have a high percentage (28) of unicolorous *nemoralis*; the De Boinville collection a low one (19) of unbanded *hortensis*. Unbanded *libellula* are uncommon (5 per cent.), and apparently commonest at Dormington (18 per cent.); in *rubella* they are commoner (12 per cent.). Banded specimens are, as a rule, rare in *castanea*, but in the De Boinville shells are 82 against 18 per cent. banded. For details see Table I.

It is considered that the normal number of bands

collection, so these *castanea* have more numerous bands. As each shell has a possible normal maximum of five bands, we may calculate what percentage of this possible total is present in each form. In all *nemoralis* it is 70 per cent., low in *castanea* (19), highest in *libellula* (78); though, if *mista* be reckoned as a separate form, it reaches a still higher average, as many *rubella* have only 20 per cent. present (B. F. 00300). For details see Table II.

The bands are of very unequal width: e.g., band 3 in *T. nemoralis* var. *rubella*, B. F. 00300, varies from 0.5, or less, to 4 mm. in width. Hence one should take into consideration the strength as well as the presence of the bands. I have tried, but in vain, to devise some accurate but at the same

TABLE II., SHOWING THE PERCENTAGE OF BANDED SPECIMENS IN WHICH EACH BAND IS PRESENT IN THE SEVERAL COLOUR-FORMS OF *TACHEA NEMORALIS*. THE PERCENTAGE OF TOTAL POSSIBLE BANDS PRESENT IS CALCULATED ON ALL, NOT ONLY BANDED, SPECIMENS.

		LOCALITY.			
		De Boinville.	Moreton.	Hunderton.	Average.
<i>T. nemoralis</i> var. <i>castanea</i> ..	Band 1	11.76	No bands.	0	3.92
	2	27.45	"	50	25.82
	3	84.31	"	100	61.44
	4	66.67	"	50	38.89
	5	56.86	"	50	35.62
Percentage of possible bands present ..	40.60	"	16.7	19.1	
<i>T. nemoralis</i> var. <i>libellula</i> ..	Band 1	50.0	81.29	71.43	67.57
	2	54.89	81.29	71.43	69.20
	3	92.39	100	100	97.47
	4	83.69	90.65	78.57	84.30
	5	82.61	90.65	78.57	83.94
Percentage of possible bands ..	67.60	88.78	78.57	78.32	
<i>T. nemoralis</i> vars. <i>mista</i> and <i>rubella</i>	Band 1	42.10	79.83	58.21	60.05
	2	46.99	84.67	68.66	66.77
	3	93.98	100	97.01	97.00
	4	78.57	89.58	71.64	79.93
	5	76.69	89.23	71.64	79.30
Percentage of possible bands ..	62.28	88.33	66.49	72.37	
All <i>T. nemoralis</i> ..	Band 1	41.92	80.28	59.04	60.41
	2	47.90	83.57	69.88	67.12
	3	92.41	100	97.59	96.67
	4	79.24	89.91	72.29	80.48
	5	76.85	80.67	72.29	79.60
Percentage of possible bands ..	61.70	83.62	65.53	70.28	

for each specimen in *Tachea* is five (hence, with *Cryptomphalus*, the atrocity of "Pentetaenia"). I have tabulated the occurrence of these bands in the various colour-forms of *T. nemoralis* from three localities. We find that in all these specimens, band 1 occurs in 60 per cent. of the banded (not total) specimens, 2 in 67, 3 in 97, 4 in 80.5, 5 in 80. Thus the order of most frequent occurrence is 3, 4, 5, 2, 1. Band 3 is very seldom absent when any other bands are present, as in *libellula* from Moreton and Hunderton, and in *rubella* and *mista* from Moreton. The De Boinville shells have several peculiarities; all bands are less frequently represented, and 1 and 2 are present in less than half the banded specimens; on the other hand, just as banded *castanea* are numerous in this

time practicable method of measuring the width of the bands; the curvature of the shell, which is not equal all round, and other practical details, have at present baffled me. Measurement under the microscope on a travelling stage seems the best, but there are obvious difficulties, and the process is a very long one, and it is a most essential and vital point in this work, where hundreds of specimens have to be worked over, that all processes should be simple and expeditious as well as accurate. Life is not long enough to do it as accurately as one might wish, but I have used the following rough-and-ready method with some success. Each band has three grades of strength: full strength represented by, say, 3; half strength,  $\frac{3}{2}$ ; quarter strength by  $\frac{3}{4}$ . Strength above full strength

is, quite improperly and unfairly, ignored. This method has at least the advantage that the numerous fallacies and inaccuracies with which it is beset are obvious on the face of it. By its use one may especially trace a series of gradations from full strength to absence in a series of band-formulae, such as, for instance, the common one in *T. hortensis*, of 12345, 13345, 14345, 10345. These results are tabulated by calculating the average strength of one band: for instance in two shells of the fairly common B. F. 32345, ten bands are present and they have a strength of nine: hence each band = 0.9, which is in fact the average strength of all the *memoralis* bands considered. Generally speaking the more often a band occurs, the greater is its average strength: thus 3 is nearly

the Old Red generally. Each hedge-bank almost has a *Tachea* fauna with individual peculiarities well marked: for instance, on a few yards of a bank near Whitecross, Hereford, *libellula* (including the unbanded form) markedly preponderates, while on an adjoining length of the same bank, and within a hundred yards, hardly anything except *T. hortensis* var. *fasciata* is to be found, though there is apparently no difference in the lie of the two pieces, their vegetation, or other circumstances. Each small locality seems to have its own at present inexplicable peculiarities, and the characteristics of the De Boinville shells may well arise from the fact that I have not collected in just those small areas which Mr. de Boinville chiefly affected—added to our different mode of collecting.

TABLE III., SHOWING THE AVERAGE BAND STRENGTH OF THE VARIOUS BANDS IN THE COLOUR-FORMS OF *TACHEA MEMORALIS*. THE VALUES ARE CALCULATED TO A DEGREE OF ACCURACY BEYOND WHAT THE METHOD OF OBSERVATION EITHER REQUIRES OR ADMITS OF.

		LOCALITY:			
		De Boinville.	Moreton.	Hunderton.	Average.
<i>T. memoralis</i> var. <i>castanea</i> .	Band 1	0.542	No bands	—	0.542
	2	0.464	"	0.250	0.357
	3	0.639	"	0.625	0.632
	4	0.493	"	0.250	0.371
	5	0.500	"	0.250	0.375
Average strength of all five bands	..	0.544	"	0.400	0.472
<i>T. memoralis</i> var. <i>libellula</i> .	Band 1	0.899	0.768	0.650	0.739
	2	0.785	0.892	0.900	0.859
	3	0.904	I	I	0.968
	4	0.945	0.996	0.954	0.965
	5	0.949	0.992	0.954	0.965
Average strength of all five bands	..	0.905	0.935	0.900	0.913
<i>T. memoralis</i> vars. <i>vista</i> and <i>rubella</i> .	Band 1	0.772	0.723	0.782	0.726
	2	0.814	0.922	0.940	0.892
	3	0.841	0.998	I	0.946
	4	0.909	0.994	0.990	0.964
	5	0.906	0.982	0.979	0.950
Average of all bands	.. ..	0.859	0.930	0.938	0.909
All <i>T. memoralis</i> .	Band 1	0.821	0.738	0.755	0.771
	2	0.781	0.912	0.905	0.866
	3	0.845	0.999	0.991	0.945
	4	0.887	0.995	0.978	0.953
	5	0.892	0.986	0.960	0.946
Average of all bands	.. ..	0.854	0.927	0.918	0.900 [0.8996]

always the strongest, and the order is 3, 4, 5, 2, 1. In all the *memoralis* considered, however, the order is 4, 5, 3, 2, 1. This is the result of the abnormalities of the De Boinville shells, where the order is 5, 4, 3, 1, 2. In *castanea* we find low values, the average being less than 0.5, and the order 3, 1, 5, 4, 2. For details see Table III.

Speaking generally, it might be said that, though the range of variation in Herefordshire is small, some interesting results may be obtained. I do not expect to find that geological formation has any constant influence in this county: the variations between the three stations on the Old Red Sandstone (Broomy Hill is half to one mile across the Wye from the Hunderton locality, and about three and a half from Moreton) are apparently almost, if not quite, as great as those between the Silurian and

To be of value, this numerical method must be widely used on some common plan, and the results from all parts collated. It is, however, a laborious and tedious task, and I am rather sceptical whether sufficient data will ever be collected in this way to make much headway with this, which is only one of many problems of conchological variation.

I have said nothing about variation in band-formulae, size, weight, shape, etc., all of which are still larger subjects than the present. As far as this county is concerned, they will be treated of in the paper on "Herefordshire Mollusca," which is in preparation for the Woolhope Club. I may mention that Mr. de Boinville alone has replied to the appeal for "sackfuls of the common snails of the hedge-bank" which I made last year.

*The Grange, Hereford; August, 1897.*

## A STRANGE INSECT.

(MEGALODON ENSIFER.)

BY MALCOLM BURR, F.E.S.

THERE are some insects that attract interest from peculiarities of habits or metamorphoses, some from their bright colours or beauty, or protective resemblance to their surroundings; but of all orders perhaps the most varied and curious forms are included in the Orthoptera. In the Orthoptera, excluding the Phasmodea, the strangest creatures are certain of the Locustodea, and one of the most striking is the insect so faithfully represented in the accompanying illustration by Mr. Fredk. O. Pickard-Cambridge. *Megalodon ensifer*, Brullé, is really a most fantastic insect, as the reader will see from the drawings.

The head of this Orthopteron seems to be disproportionately large, and the jaws are big and powerful, their shining black colour making them conspicuous. In front of the head is a curious knob, and there is a sharp spike on the top of the head between the antennæ. The pronotum is the most formidable part; it is very large, and has the appearance of a pincushion with the pins pointing outwards; on each side there are two large spiky processes, each armed with several stout spines. It is produced backwards, something like a saddle in shape, but it would make a most uncomfortable saddle, as, in addition to these great thorns mentioned, there are sundry points and spikes, all sharp and long. The legs are armed with rows of similar spines, even the coxæ being provided with them.

The wings and elytra are short and probably useless for flight, but in the male apparently act

as a musical apparatus. The female has a great sword-shaped ovipositor, with a head and pronotum much out of proportion to the rest of the creature. It is probably not a very active insect, but more likely is a clumsy thing, capable of making short leaps. It is a most formidable animal, and, like all carnivorous Locustodea, would be likely to give a good nip with its powerful jaws. It should be safe from its enemies; birds at least would find it a tough and indigestible morsel.

Although practically nothing is recorded of its habits and haunts in a wild state, *Megalodon ensifer* has been known to science for over sixty years, having been first described by Brullé in 1835. It has since been noticed by several authors, as Serville, Burmeister, Blanchard, De Haan, Charpentier, Westwood, Redtenbacher and Brogniart. The genus *Megalodon* is placed by Brunner in the Conocephalidae, where it is retained by Redtenbacher in his recent excellent Monograph of that family; but Brogniart refers it to his genus *Eumegalodon*, for which he has erected a new family, Eumegalodontidae, where he also ranges another species, *Eumegalodon blanchardi*, if possible a more formidable insect than the species

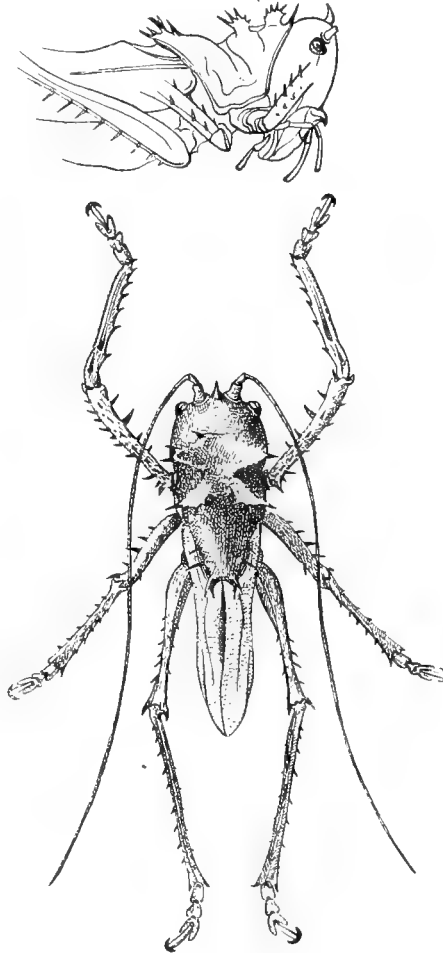

MEGALODON ENSIFER.

Dorsal view and side view of head and thorax of male.

before us. There is a fine figure of that remarkable insect in Dr. Sharp's excellent contribution upon "Orthoptera" in the "Cambridge Natural History." *Megalodon ensifer* is a native of Java, Borneo and Sumatra. The specimen from which the above drawing was taken was captured at Mons Cédé in Western Java.

Bellagio, East Grinstead; August 20th, 1897.



## JACKSON-HARMSWORTH ARCTIC EXPEDITION.

MR. FREDERICK G. JACKSON, who left England on 11th July, 1894, in charge of the Jackson-Harmsworth expedition to the northern polar regions returned to the Thames on September 3rd. There accompanied him home on the steam-yacht "Windward," Lieutenant Armitage, R.N.R., who was the astronomer of the expedition; Dr. Köttlitz, medical officer, Mr. W. S. Bruce, the zoologist, and Messrs. Heywood and Wilton. The "Windward" left Franz Josef Land on August 6th, and had experienced rough weather most of the voyage. It is interesting to note that no member of the party had suffered from any illness during their prolonged stay in those ice-bound lands.

The energies of the explorers have been given to exploring Franz Josef Land, which they appear to have exhaustively accomplished.

The winter of 1896-1897, which was less severe than usual, was passed very happily, many scientific observations and researches fully occupying the party. Active work commenced on March 16th, when Messrs. Jackson and Armitage went with sledges, dogs and a pony round the north of Franz Joseph Land and defined its contour. They encountered very bad weather—mist, rain, gales and snow, and a temperature of 40 degrees below zero. The pony and most of the dogs died from exhaustion. Many important geographical discoveries were, however, made. The energy necessary to make that journey as successful as it turned out must have been remarkable, for everything that well could occur was against its accomplishment. The northern coasts of the great island were surveyed sufficiently to be mapped correctly. Where a continent was formerly supposed to exist Mr. Jackson has found numerous islands and sea. Where mountains appear on our present maps are hummocks of ice-packs with an open sea to the northward. It is probably the most northern open water in the world; he named it Queen Victoria Sea.

The scientific discoveries will be published at a later date, and are stated to be important. They embrace three years' study of the magnetic and meteorological observations; also geological, botanical, and zoological collections. The secret of the good health of the party may be summed up in Mr. Jackson's excellent arrangements for fully occupying everyone for a sufficient number of hours each day, in addition to close attention to bodily exercise and cleanliness. They had plenty of food, having lived almost entirely on "looms," birds of a guillemot family, of which Mr. Jackson shot no less than 1,400 last autumn for the winter supply. At the time of obtaining these birds,

Mr. Jackson set free nineteen looms and twenty-two kittiwakes, with a copper label attached to each marked with the letter J. These birds may be found on our northern coasts or elsewhere in North-East Europe, and should be recorded, with date and place of observation.

The lowest temperature during last winter was forty-eight degrees below zero (Fahr.), which is not nearly so low as occurs every winter in North-Central Asia or America.

Mr. Jackson was induced to join Mr. Harmsworth in the expedition with the hope of reaching the Pole. He based his opinions on the maps of the day. Now, however, he believes that to reach the Pole may be possible, but the enormous difficulties render its discovery by way of Franz Josef Land very doubtful. He has shown that large tracts of land marked on maps have no existence, and others are more or less mythical. Among the latter may be classed Petermannland and King Oscar Land. Neither does there exist evidence of any land north of the islands off Franz Josef Land. Gillis Land will have to disappear from our maps, as its existence is found to be a mistake; its site is occupied by open sea.

The grip of the fascination for Arctic exploration has, as is usual with like explorers, got a firm hold of Mr. Jackson, who contemplates another expedition.

## THE NATURALISTS' DIRECTORY.

MAY I be allowed to appeal to your readers for some assistance towards making the 1898 edition of the "Naturalists' Directory" of more value and assistance to naturalists than the preceding editions have been. What I particularly desire is that the secretaries of the numerous local natural history societies and field clubs throughout the British Islands should send me lists of the officers for 1898, with the secretaries' addresses, particulars of meetings, etc. Failing the secretaries, perhaps a member of the society would see to this information being sent, as I have previously appealed to the secretaries without any great result. I should also be grateful to editors of foreign magazines devoted to natural science who would send me a copy of their magazine, to enable me to include it in the list of periodicals, with proper particulars, the list in the Directory being at present rather imperfect in respect to foreign magazines. Finally, I may mention that British or foreign students of natural history who wish their names inserted can obtain a prospectus from the publisher (Mr. Upcott Gill, London), by applying on a postcard with address.

H. KIRKE SWANN.

10, Harrington Street, London, N.W.

Editor of "Naturalists' Directory."

## ARMATURE OF HELICOID LANDSHELLS.

BY G. K. GUDE, F.Z.S.

(Continued from page 103.)

*PLECTOPYLIS SCHLUMBERGERI* (figs. 58 *a* and *b*), from Halong Bay and Elephant Mountain, Tonkin, was described and figured by Mr. J. Morlet, in the "Journal de Conchyliologie," xxxiv. (1886), pp. 259 and 272, t. 12, f. 2. The shell is dextral, discoid, solid, and widely umbilicated; it is shining, brown, coarsely striated and decussated by spiral lines above, smooth below. The spire is a little raised and there are seven whorls, which are obsoletely keeled above, and subangulated



Fig. 58.—*Plectopylis schlumbergeri*. (*a*, original; *b*, after Morlet.)

below; the last whorl does not descend in front; umbilicus deep, funnel-shaped. The aperture is ear-shaped, and the peristome is white, thickened and reflexed, its margins united by a sinuous raised ridge, which gives off about the middle, a short, entering, obliquely ascending fold. The parietal armature further consists of a vertical plate, with a slight denticle anteriorly near its lower extremity. The palatal armature consists of six small, narrow teeth. I do not possess a specimen of this shell, and as there is only a single specimen of this species in the British Museum, I have not had an opportunity of examining the armature; consequently I have been obliged to rely on the somewhat meagre description of Mr. Morlet, and upon his figure of the armature (op. cit. fig. 2*c*), which latter I have copied (fig. 58*b* giving the anterior aspect of the parietal and palatal armatures.) The shell is stated to measure—major diameter, 26 millimetres; minor diameter, 22 millimetres; height, 12 millimetres; but the specimen in the British Museum (fig 58*a*) measures—major diameter, 19 millimetres; minor diameter 16 millimetres; height, 8.5 millimetres. In addition to the original locality the species has been collected at Nuy-Dong-Nay, Tonkin (Dautzenberg and d'Hamonville, "Journal de Conchyliologie," xxxv. (1887) p. 218).

*Plectopylis jovia* (figs. 59 *a* and *b*), from Halong, Tonkin, was described by Mr. Jules Mabilie in the "Bulletin de la Société Malacologique de France," iv. (1887), p. 99. It was figured by Mr. Pilsbry in his "Manual of Conchology," ix. (1894), t. 40, figs. 1-4, from specimens forming part of the original lot

collected by the Abbé Vathelet. It is allied to *Plectopylis schlumbergeri*, and like that species it is, unfortunately, represented by a single specimen in the British Museum and I have in this case also been unable to examine the armature. Mr. Pilsbry's figure of the structures in question, however, is so good, and his description so minute, that I will copy both.

"Shell depressed, discoidal, very broadly umbilicated, the umbilicus regular, funnel-shaped, its width contained not quite two and a-half times in the diameter of the shell; solid, opaque, obliquely striulate and decussated by sub-obsolete microscopic spiral lines above; reddish under a (deciduous?) yellowish-brown cuticle; lustreless. Spire slightly convex, composed of seven and a-half very slowly increasing whorls; the last whorl wider, rather strongly deflexed in front, very convex beneath, and obtusely subangulated around the umbilicus. Aperture oblique, rotund-truncate, the peristome well curved, strongly reflexed, its face white and thickened, ends joined by an elevated lobe of the parietal callus, from which an entering lamella arises extending a short distance inward. At the last third within the whorl it is obstructed by a broad, curved, transverse parietal plate, the convexity of the curve outward, the upper border of it slightly scalloped; a minute denticle stands in front of the lower end of this plate. The outer wall bears seven plicae: the two outer small, parallel to the sutures; the next to the lowest fold

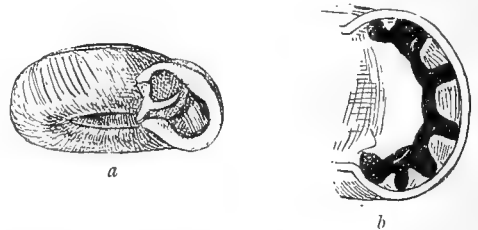

Fig. 59.—*Plectopylis jovia*. (*a*, original; *b*, after Pilsbry.)

very minute, situated somewhat back of the others; the four median larger and directed obliquely across the whorl. Altitude, 13 millimetres; diameter, 29-31 millimetres. It is not improbable that both *jovia* and *villedaryi* will prove to be varietal forms of *schlumbergeri*" (Pilsbry, "Manual of Conchology," viii. (1893), p. 156).

Fig. 59*b*, enlarged, is copied from "Manual of Conchology," ix. (1894), t. 40, f. 4. The specimen shown in fig. 59*a* is in the British Museum, and

measures—major diameter, 30 millimetres; minor diameter, 26 millimetres; altitude, 15 millimetres.

*Plectopylis villedaryi* (figs. 60 a and b), from Langson and Bac-ninh, Tonkin, was described and figured by Mr. C. F. Ancey in "Le Naturaliste," 1888, p. 71, f. 2. Mr. Pilsbry has illustrated the armature in "Manual of Conchology," viii. (1893), t. 43, f. 39, which I have been obliged to copy, having only seen one unbroken specimen of this species. The shell is solid, depressed, disk-shaped, regularly ribbed with minute spiral sculpture above, the ribs being particularly conspicuous in the wide funnel-shaped umbilicus. There are six and a-half whorls, which increase slowly and regularly, the last descending in front, very convex and subangular around the umbilicus. The aperture is very oblique, somewhat ear-shaped, and the peristome is very much thickened and reflexed, the margins being united by an elevated tongue-shaped ridge on the parietal

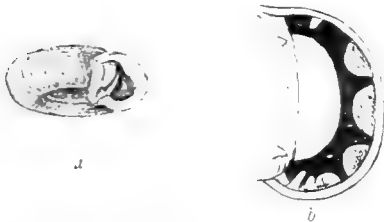

Fig. 60.—*Plectopylis villedaryi*. (a, original; b, after Pilsbry.)

callus. A stout curved plate is given off from this ridge, rising obliquely (see fig. 60a). The parietal armature is composed of a strong vertical plate with two denticles anteriorly, one near the upper and one near the lower extremity, the upper one smaller, the lower one elongated (see fig. 60b, which gives the anterior view of both armatures). The palatal armature consists of seven folds, the first small and thin, near to and parallel with the upper suture; the second, third, fourth and fifth larger, oblique; the sixth very minute and situated to the rear of the others; the seventh small, near to and parallel with the lower suture (see fig. 60b). The measurements given are: major diameter, 20 millimetres; minor diameter, 17 millimetres; altitude, 9 millimetres. The shell in the British Museum (shown in fig. 60a) measures—major diameter, 19 millimetres; minor diameter, 16½ millimetres; altitude, 8 millimetres.

*Plectopylis phlyaria* (figs. 61a-c), from Tonkin, was described and figured, by Mr. Mabille, in "Bulletin de la Société Malacologique de France," iv. (1887), p. 100, t. 2, ff. 1-3. Unfortunately the armature does not appear to have been examined by Mr. Mabille, for not only has he omitted to illustrate it, but no mention is made of it in his diagnoses, and to my great regret these important structures

remain unknown to me. Not having been able to obtain a specimen of this species I have been under the necessity of copying Mr. Mabille's figures and description. The shell is "openly umbilicated, depressed discoid, thin, somewhat solid, scarcely

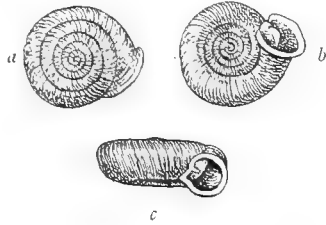

Fig. 61.—*Plectopylis phlyaria*. (After Mabille.)

shining, dull whitish under a deciduous, greyish, hairy cuticle, arcuately striated, and seen under a lens to be covered with imbricating lamellae. Spire flat, apex shining, smooth, corneous. Whorls seven and a-half, narrow, convex, rather rapidly and regularly increasing, separated by a deeply impressed suture. The last whorl large, but little wider than the preceding whorl if viewed from above; laterally compressed, obscurely angulated at the periphery, deeply descending in front, tortuous, a little convex beneath. Aperture half round, toothed, the margins connected by a transverse parietal lamina, behind which a dentiform callus emerges; peristome white, thick, reflexed. Major diameter, 15 millimetres, minor diameter, 13 millimetres; altitude, 5.5 millimetres."

(To be continued.)

PLYMOUTH LABORATORY.—The first number of Volume v. (N.S.) of the "Journal of the Marine Biological Association of the United Kingdom" is to hand. Accompanying this part is the contents and index of the preceding volume. An important paper is contributed by the Hon. Secretary to the Association, Mr. E. J. Allen, B.Sc., on the Migrations of the Mackerel (*Scomber scomber*). Among other papers is one by Mr. E. W. L. Holt, on "Notes on the Reproduction of Teleostean Fishes in the South-Western District"; "New or Rare British Marine Polyzoa," by S. F. Harmer, M.A., B.Sc.; on "*Tubularia crocea* in Plymouth Sound," by Edward T. Browne; "An Account of the Scientific Work of the Northumberland Sea Fisheries Committee," by Alexander Meek, M.Sc., and other information of a more general character. The Norway pout (*Gadus esmarkii*) is recorded by Messrs. Matthias Dunn and E. W. L. Holt, as having occurred in the English south-western district. Mr. Dunn deserves high credit for adding this station to the list of localities for this species of the genus *Gadus*. They were found by following up a train of thought as to the probable food of the numerous hake (*Merluccius vulgaris*), taken beyond the entrance to the Bristol Channel. It was only by examining the contents of the freshly caught larger fish that the discovery was made. This little *Gadus* is a deep-sea fish, occurring at from 26 fathoms to 144 fathoms. Though interesting to naturalists it has no commercial value.

## CHAPTERS FOR YOUNG NATURALISTS.

(Continued from Vol. III., page 131.)

## MARINE FAUNA OF FOLKESTONE.

BY W. H. PARRITT.

ALTHOUGH Folkestone is well known to geologists and entomologists, yet I do not think it has been recommended as a hunting-ground for the marine zoologists. I can, however, say from personal experience that it is as good as, and in many respects better than, most of our south and south-eastern watering-places.

Of all branches of natural history, that of marine zoology has had the least attention paid to it in the past, and even now comparatively little is known about the habits and life-history of many the curious inhabitants of the sea. Not only does the study of marine life offer to the patient student many opportunities for discoveries of new species, or new facts in the life-history of the creatures, but it is also one of the most entrancing of all studies. Only those who have tried it know what pleasure there is in unexpectedly finding a rare crustacean or echinoderm under a stone or in a rock pool. It is pleasing to say, that owing largely to the biological laboratories and also the natural history museums in various parts of the country, the study of marine zoology is becoming more general. It is chiefly for the information of the younger readers of SCIENCE-GOSSIP that I have written this Paper, descriptive of a few of the curious objects to be found on the shore at Folkestone. For the last three or four years I have spent my annual holiday at this well-known seaside resort, and as a result of my shore-hunting have brought home many a specimen for my cabinet.

I will imagine that I am accompanied by a young novice to this branch of natural history, to whom I will point out where to look and what to look for. Let us choose for our trip to the shore a day on which there is a spring tide, when the sea recedes much further than usual, and leaves bare many rocks which are generally covered by the waves.

I have found the rocks at the foot of Copt Point, to the east of the town, by far the most prolific of life, and therefore the best place for shore-collecting. The rocks there extend some distance seawards, and are covered with a thick growth of algae, forming many small hollows and pools, which are just the places we may expect to find inhabited by the creatures we are in search of. Many of the stones are loose, and can be turned over with a little amount of exertion, and some of the rarest specimens are to

be obtained in this way. I am sorry to say that, as the South-Eastern Railway authorities are enlarging the harbour at Folkestone, these rocks will probably have to be removed. There are, however, other rocks at the west end of the town, below the Leas, which no doubt will yield most of the creatures to be found at Copt Point.

Of course, the first object seen as we walk along the shore is the common shore-crab (*Carcinus maenas*). If we want large specimens of this crab, we must wait until we arrive at low-water mark, when we shall find plenty under the stones and algae. As we step on the rocks we find other forms of life, the commonest, with the exception of the acorn-shells and sea-anemones, being the five-finger star-fish (*Uvaster rubens*). These are extremely plentiful at most seaside resorts where there are rocks, and abound in such numbers at some places that they are used as manure for the fields. They vary greatly in number even at the same place, for one day they may be seen in hundreds, and a few days afterwards only a few comparatively can be found. I have obtained several of this star-fish, both at Folkestone and Eastbourne, with six rays, and one with seven rays, but these require careful looking for. I have often been surprised at the large number of urasters to be seen here showing the reproduction of their rays. They may be found in quantities with from one to four of their rays much shorter than the others, and some of them are extremely curious. This and several other species of star-fish have the power of reproducing any of their rays or arms which are either injured or broken off.

Let us now look into one of the rock pools near low-water mark, and see if there is anything hidden there. Here is a pool fringed with long seaweed, in which we are sure to find something interesting. Now turn over very carefully and quickly that large stone. At first sight there does not appear to be much on the under surface, but we will look more closely at it presently. Let us first of all see what creatures we have disturbed by moving the stone. There is a fine green crab (*Carcinus maenas*) trying to hide himself in that hole. Be careful how you pick him up, as they are very pugnacious, and will often give you a good nip. Here is another crab, but very different from the one we just saw. It is a small specimen of the edible crab (*Cancer pagurus*). These are seldom found on the shore with a carapace of more than three or four inches wide.

The large ones exposed for sale in fishmongers' shops are caught in baskets in deep water. Stop! what are those things dashing about so quickly in the pool? Catch one in the net, and you will find it is a small crustacean, two or three inches long, something like a lobster, but with a shorter tail. They are called *Galathea squamifera*, and are a kind of connecting-link between crabs and lobsters. Now let us look at this rather uninviting stone that we turned over just now, and see what there is clinging to its under surface. See what curious little crabs those are wriggling about and trying to hide themselves in the cracks and crannies. They are the porcelain crab (*Porcellana platycheles*), and abound in vast numbers under nearly every large stone. You must be very careful in picking them off the rock, as they have a curious habit of throwing off their broad front claws when touched. See also how small and rudimentary are their last pair of legs. Here is a crab very closely related to *platycheles*, although it is very different in appearance. It is named *Porcellana longicornis*, and has very long pincers for such a small crab. Lift up that weed and you will probably see a specimen of *Xantho rivulosa*. This is a pretty crab with powerful claws, and is rather common at Copt Point. I have also found here several specimens of the spider-crabs (*Hyas coarctatus* and *H. araneus*) quite covered with algae and zoophytes.

Let us look again at our stone, as I think we shall be able to find some brittle star-fish. Yes, here is one, about two or three inches in diameter. It is called *Ophiocoma rosula*, and is so brittle that we shall have to lift it off by passing a knife under it. There are also several small brittle stars (*O. neglecta*) which, like many other species found around our coasts, can at will throw off their rays. The best way to kill them is by dropping them quickly into some fresh water.

Here is something under this piece of alga which we did not notice at first. It is a sea-hedgehog or urchin, and has the scientific name of *Echinus mitis*. It is closely related to the star-fish, although it appears so dissimilar. It is a very curious creature. If, however, you wish to learn something about its habits, take one home with you in a jar of sea water, and watch it crawl about with its hundreds of tube feet.

Around the edge of the pool, where it is clear of algae, you will probably see some roughly made tubes of sand. Break off a small piece and let us examine it. It has been made by, and is the home of, a number of small worms, and if you look closely you will see the heads of several of them peeping out. It is the *Sabella alveolata*, and I have found large masses of it at Folkestone. The tube of another worm (*Urechis littoralis*) may also be found in the sand. This worm lives in a very

different tube from the other, and lies buried in the sand, with only its tentacles above the surface. The tube is made by the worm from sand and pieces of shell, but unlike the fragile tube of the *Sabella* it is fairly tough and flexible. Great care must be taken in getting it out of the sand, the best way being to dig it out.

Other crustaceans may sometimes be found under the stones or in the rock pools, such as *Corystes cassivelaunus*, or the mask-crab, so called from a curious impression of a face on the back of its shell or carapace. *Crangon vulgaris*, or the common shrimp, together with one or two other varieties of shrimps, and *Palaemon serratus*, or the prawn, may be seen in the rock pools at low tide.

I think we have now got to the end of the larger objects in and around this pool, and this may be taken as an example of what may be found by anyone, without much trouble. Of course there are numerous other forms of life besides those I have mentioned. If you have a microscope, you will find sufficient to employ your time for many evenings. Numbers of zoophytes of different kinds may be seen attached to the larger species of algae or to the rocks. The beautiful and interesting *Lucernaria campanulata*, a medusian, may be found in great numbers at Folkestone, attached to the Fuci.

If you keep a marine aquarium, you can obtain in a few minutes a sufficient number of sea anemones of four or five kinds to stock it, and make it alive with these beautiful flower-animals of various hues.

Many rarer specimens inhabiting the deep sea of the Channel may be obtained in the fish market at Folkestone, when the boats arrive laden with fish. In this way I have obtained two or three species of sea and shore spiders, sand-stars (*Ophiura texturata*), sea mice (*Aphrodite aculeata*), two or three varieties of *Portunus*, or swimming-crabs, the long-legged spider-crab (*Stenonychus tenuirostris*), and many others.

Perhaps it will be as well if I give a few directions for preserving the specimens we have found. It is best, if possible, to kill the animals as soon as they are caught, and this may be done by taking some jars or bottles of fresh water. Drop the crustaceans and star-fish into this, and they will soon die. Do not use spirit, as although this will kill them, yet it will spoil the colour of many species. On arriving home the specimens must be thoroughly washed in fresh water to get rid of the salt, and then, in the case of the star-fish and smaller crustaceans, they may be spread out on a board to dry in a cool place away from bright sunshine. In the case of the larger crabs and lobsters, the carapace, or shell, and the large claws should be removed, and as much as possible of the flesh taken out before being dried.

The inside of the shell and body should also be dusted over with powdered alum.

In conclusion, I would strongly recommend any young person who is fond of natural history to take up this most interesting branch, and he will find that the summer holiday is much more enjoyable from having a hobby of this kind, besides the winter's work among the specimens collected.

8, Whitehall Park, London, N.

### RARE ANIMALS IN LONDON.

AMONG the additions made to the Zoological Gardens during the present year, there are several species which have not previously been represented in the society's collection. A female specimen of the tantalus monkey (*Cercopithecus tantalus*) was received from the Upper Benué River, West Africa. In the "Small Cats' House" there are some examples of the Egyptian weasel (*Mustela subpalmata*); this beast differs considerably from our own species (*M. vulgaris*), being larger and of a somewhat lighter colour. The bridled wallaby (*Onychogale frenata*) is a member of a genus of kangaroos, known as "spur-tailed" wallabies; there are three species, which have the tip of the tail furnished with a horny spur, similar to that of the lion. One of them, the lunulated kangaroo (*O. lunata*), was living in the gardens about thirty-two years ago. The present species comes from Eastern Australia. The new birds include specimens of the Moluccan kestrel (*Tinnunculus moluccensis*) from Triton Bay, New Guinea; the paradise parrakeet (*Psephotus chrysopterygius*) from Australia, and the pigmy goose (*Nettion coromandelianus*), of which three examples were presented by Mr. Finn, of Calcutta. Many unsuccessful attempts have previously been made to introduce this bird into Europe. There are also several new reptiles, among which may be noticed an angulated snake (*Helicops angulatus*) from the West Indies, a Hallowell's tree-snake (*Dendraspis viridis*) from West Africa, some examples of Sharpe's tortoise (*Testudo emys*) from Borneo, and a Cuvier's scolecosaur ( *Scolecosaurius cuvieri*) from Trinidad.

GUY MERCER, F.Z.S.

200, Adelaide Road, South Hampstead, N.W.  
September 2nd, 1897.

WHITE STORK IN SUSSEX.—Our local taxidermist, Mr. Richardson, has on his premises, where it may be inspected, a fine male specimen of the white stork (*Ciconia alba*), which was picked up dead, on August 18th, on New Barn Farm, Colgate, about four miles north-east of Horsham. It was found to have been shot—*Chas. J. Marten*, 30, London Road, Horsham.



NOTICES BY JOHN T. CARRINGTON.

*A Guide to Zermatt and the Matterhorn.* By EDWARD WHYMPER, 212 pp. 8vo, profusely illustrated. (London: John Murray. Geneva: Georg and Co., 1897.) Price 3s.

On taking up a guide-book to a popular Swiss tourist district, one hardly expects to find one of the most fascinating stories it has been our pleasure to read for many a year past. Written, as it is, by the most experienced and trustworthy of Alpine climbers, it has the additional advantage of being a true story. In this unpretentious Guide will be found a history of indomitable perseverance, crowned by ultimate success. It is the story of the conquering of the Matterhorn, that terrible and fatal Alpine peak which has cost so many lives to surmount. Mr. Whympers writes so graphically and vividly that one loses the remembrance of reading and imagines oneself present at the incidents he relates. There is no attempt at word-painting, but we have seldom met with word-pictures that fix themselves so sharply on one's imagination. His story of his ultimate success, accompanied by a party of seven others, including three Englishmen, Lord Francis Douglas, the Rev. Charles Hudson and Mr. Hadow, the rest being experienced guides, is one to read over and over again. The fatiguing difficulties of the ascent; their frantic joy on reaching the summit; their dangerous descent; the slipping of Mr. Hadow, the startled exclamation from the guide, Croz, and the descent of both with Hudson and Lord Francis, with a sharp snapping sound of the connecting rope, then the sheer drop of four thousand feet of these four men, is something to dream about. Hardly worse, is his description of the terror and unnerved condition of the survivors. The historical part of this Guide is indeed a series of exciting narratives of daring and doing, which should be read by all conditions of people, whether travellers or those who stay at home. The book is a mixture of common sense, useful instructions, bright anecdote and pathetic stories of terrible storms, danger and death. This Guide-book is far more than its name pretends. The illustrations are well chosen and highly instructive.

*Humane Science Lectures.* By various authors 181 pp. 8vo. (London: George Bell and Sons, 1897.) Price 2s.

In this little work, which is published for the Humanitarian League, are four lectures: (1) "The Need of a Rational and Humane Science," by Edward Carpenter; (2) "The Humane Study of Natural History," by J. Arthur Thomson, M.A.; (3) "The Treatment of Prisoners," by Rev. W. Douglas Morrison; (4) "Suggestion: Its Place in Medicine and Scientific Research," by Dr. J. Milne Bramwell. There is an Appendix giving a short report of a lecture by Prince Peter Kropotkin. It is hardly necessary here to say more about these lectures than that they were given under the auspices of that excellently well-meaning society.

the Humanitarian League. They consequently appeal rather to the heart than to that cold, critical unbiassed mind which approaches science or sociology only for truth's sake.

*The Flora of the Alps.* By ALFRED W. BENNETT, M.A., B.Sc., F.L.S., 8vo, Vol. i., Parts iii., iv., v. and vi., with 64 coloured plates. (London: John C. Nimmo, 1897.) Price 2s. 6d. each, net.

We have already had the pleasure of recommending this work to our readers (in May and June numbers of SCIENCE-GOSSIP) as a most useful book for Alpine travellers, whether botanists or not. Part iii. continues Leguminosae, proceeds to Rosaceae, Saxifragaceae, Crassulaceae, etc.; there being seventeen coloured plates. In Part iv. are thirteen plates, devoted in part to Umbelliferae, Caprifoliaceae, Rubiaceae, Campanulaceae, etc. Part v. contains Compositae, Vaccineaceae, and Ericaceae. These natural orders are represented in this part by eighteen coloured plates. Part vi. has sixteen plates, including Gentianaceae, Convolvulaceae, and some other orders of plants. The work fully maintains its useful character as it proceeds. Part iv. completes half the work, which, by the cost being spread over monthly payments of half-a-crown, comes within the reach of every lover of flowers, whether traveller or otherwise.

*British Game Birds and Will Fowl.* By BEVERLY R. MORRIS, M.D. Revised by W. B. TEGETMIER, F.Z.S. Parts v. and vi. Super royal 8vo, with coloured plates. (London: John C. Nimmo, 1897.) Price 2s. 6d. per part, net.

Part v. of this work, to which we have previously referred, contains four coloured plates, including those of the great plover, golden plover, dotterel and woodcock. They are followed in Part vi. by a couple of plates, one of the great snipe and the other of the common snipe.

*A Short Synopsis of English History.* By J. C. WRIGHT. 63 pp. 8vo. (London: Relfe Bros., Limited, 1897.) Price 6d.

This book certainly takes the palm for conciseness, but as we have frequently remarked in our notices of text-books generally, conciseness coupled with the modern system of cramming for public examinations is not education in the true sense. For the purpose for which it is intended this little book will doubtless find purchasers, as it appears to be correct as far as it goes.

*Pictorial Instruction Object Lessons.* By G. Colomb, D.Sc. 141 pp. small 4to. (London: Relfe Bros., Limited. Paris: Armand Colin et Cie., 1897.) Price 2s. 6d.

This book, which is by the Assistant Director of the Botanical Laboratory of the Faculty of Science, Paris, has been adapted into English by Seymour J. Gubb, B.A. It is one we can recommend for young children after they have learned to read. It is, in fact, a course of little lessons of only two or three lines each, upon the most common objects which we see around us in daily life. These little lessons are illustrated by 650 drawings, each of which leads the child to enquire for the answer, which is found beneath each drawing. They are arranged in subjects which are again sub-divided, showing the raw condition of common materials and their adaptation to men's requirements either by manufactures or artistic work. The book will be found an aid to advanced kindergarten teaching.

*The Evolution of the English Alphabet.* By HENRY GEO. TAYLOR JONES, B.A. (London: Relfe Bros., Limited, 1897.) Price 6d.

This is a diagram, arranged upon a piece of stiff cardboard 14 inches by 11 inches in size, indicating for educational purposes the evolution of the letters of our alphabet. The changes in form—from the hieroglyphics of the Egyptians over two thousand years before Christ, through the hieratics, or abridged forms of hieroglyphics, to the Phoenician characters, and on to Greek, Ancient Hebrew, Latin, and thence to our familiar capitals and smaller letters—are traced for the benefit of scholars. At the back of the card are explanations and notes upon the origin and progression of each of the twenty-six letters constituting our alphabet.

*Smithsonian Institution. Annual Report to July, 1895.* 837 pp. large 8vo, with illustrations and maps. (Washington: Government Printing Office, 1896.)

This massive volume, as it is usual with these reports, is of a highly interesting character. It seems a pity, however, that these volumes are so far behind the date of the material printed, especially is this so with regard to the extracted articles from other journals, which always form a feature of the Smithsonian Reports. As an instance, we would mention that the opening address on "Oceanography, Bionomics, and Aquiculture" at the Ipswich Meeting of the British Association, in 1895, by Dr. Herdman, F.R.S., is included in the volume received in September, this year. It happens, perhaps, that we notice such articles in consequence of our familiarity with them; but referring to some others of about the same period which we had not previously seen, they come to us with the freshness of recently published information. Among the general articles in the appendix are three upon the relation of life and the atmospheric air which supports it. These are the result of the competition for prizes given out of the Hodgkin's Fund of the Smithsonian Institution. The first is entitled "Air and Life," by Dr. Henry de Varigny, of Paris; "The Atmosphere in Relation to Human Life and Health," by Francis Albert Rollo Russell, of London, and "The Air of Towns," by Professor J. B. Cohen, of the Yorkshire College, Leeds. These articles are of great importance, and it would be well if the Board of Regents of the Smithsonian Institution could see its way to publish for sale these Papers as an independent book. We believe the issue would command considerable attention and many readers. In this report they occupy about 280 pages, with some interesting plates. Among other subjects is "Zoology since Darwin," by Professor Ludwig V. Graft, which is the well-known discourse he delivered before the Imperial Royal Charles Francis University, November 4th, 1895. It has been translated for these pages, and is illustrated by a not very good copy of the Hon. John Collier's portrait of Darwin at the Linnean Society, or its replica at the National Portrait Gallery. The Archaeological papers in this volume are particularly interesting, as are also those on Anthropology. Among the plates is a reproduction of Mr. Collier's portrait of his father-in-law, the late Professor Thomas Henry Huxley. It illustrates a memorial address on Huxley and his work, by Theodore Gill, given on January 14th, 1896, before the scientific societies of Washington.

## SCIENCE IN SOME MAGAZINES.

NOTICES BY JOHN T. CARRINGTON.

THE "GENTLEMAN'S MAGAZINE" (London: September, 1897, 1s.). This number of the "Gentleman's Magazine" has passed the remarkable figure of 2,000 monthly issues, being 2,001, volume 283. From its very commencement the honourable line of editors under the *nom-de-plume* of "Sylvanus Urban, Gentleman," has ever encouraged an interest in science, keeping watch on the passing events and discoveries of the period. In the number for September, Mr. A. Macivor popularly treats on the use of "Balloons and Kites in Meteorology." He has compiled a number of curious and very interesting facts, which are told in such pleasant style that the least informed reader becomes interested in active human observations from balloons at such enormous altitudes as 31,500 feet, or nearly six miles, and the passive records of automatic instruments carried by kites to a third of that distance in altitude. The most important results in meteorological research obtained by kites were, and we may add are, as recently mentioned in SCIENCE-GOSSIP, at the Blue Hill Meteorological Observatory, Milton, Mass., U.S.A., which stands at an altitude above the sea of 635 feet. The self-recording meteorograph attached to the kites weighs only three pounds, and records with great accuracy temperatures, humidity and atmospheric pressure. The general weather conditions at a mile above the observatory have now been watched for some time. It is found at that height the temperature is from 15° to 25° Fabr. colder than at the surface, with a virtual absence of daily range, the nights being as warm as the days, and the only changes are the results of passing warm or cold waves. The days at that elevation in fine weather are damp; but the nights are extremely dry. The sun is frequently shining brightly up there when for lengthened periods rain is falling below. The velocity of the wind is four times greater than that on the ground, often blowing at the rate of 100 miles an hour. The importance of these researches upon the future of weather forecasting is manifest on reading Mr. Macivor's article.

PALL MALL MAGAZINE (London: September, 1897, 1s.). "Elephant Catching in India," with thirteen pictures from photographs taken on the spot, appeals to the field naturalists. It is by Surgeon-General Sir B. Simpson, K.C.I.E., and Colonel Cuthbert Larking. There are touches of natural history in this article, as well as the description of scenes dear to the naturalist sportsman.

CORNHILL MAGAZINE (London: September, 1897, 1s.). Mr. Frank T. Bullen writes upon "Antarctic Exploration," in which he reviews the work already done on the fringe of the southern ice cap. His contribution points out that not only may science be enriched by a continuance of the researches in those frigid seas, but commerce also, by the rehabilitation of the sperm whale fishery between the parallels of 50° and 60° south, where those gigantic mammals abound in vast numbers, and are of immense size.

APPLETON'S POPULAR SCIENCE MONTHLY (New York: September, 1897, 50 cents). This is a bright number, and contains among its fourteen

articles several which appeal to lovers of natural science. Mr. Wm. E. Cram has an illustrated description of "The Hawks of New England." The eight drawings are picturesque. Botanists will find Professor James W. Toumey's article on "The Giant Cactus" of the foothills, by the Salt River Valley and downwards into Mexico. There the plants grow by "hundreds on a single acre, many extending their huge green columns to the height of fifty feet." The two illustrations depict these weird-looking vegetable monsters. For the same class of readers Dr. George J. Peirce writes on "The Scope of Botany." He reviews the many fields for botanical work in its varying branches, whether microscopic or otherwise. He takes for his text the familiar quotation, "Botany is that science which seeks to answer every reasonable question regarding plants." There is an illustrated biography of the Rev. Samuel Lockwood, Ph.D., a well-known naturalist and shrewd observer, born at Mansfield, in England, who died at his home in New Jersey, on January 9th, 1894, aged seventy-five years. He went with his father to New York while quite a little boy. Singularly unassuming, he left behind not only his mark as an investigator but his influence as an encourager of others to take up the study of natural history.

THE AMERICAN JOURNAL OF SCIENCE (New Haven, Conn., September, 1897) contains several articles on North American geology and one relating to a new tertiary horizon in Southern Patagonia.

THE EDINBURGH REVIEW (London: July, 1897). This number contains an article on the two late English mathematical astronomers, whom the review calls "the greatest we have had in England since the days of Newton." The notes are (1) "On the Autobiography of Sir George Biddell Airy, K.C.B.," and (2) "The Scientific Papers of John Couch Adams, F.R.S." Mr. C. Lloyd Morgan, F.G.S., on "Habit and Instinct," is considered. The review is a careful comparison of the definitions given to these two words by various authorities. Several examples of what is usually called instinct are given. Professor Lloyd Morgan himself considers that the term "instinctive" should be confined to those "activities" which are in a greater or less degree congenitally definite, and in this sense uses the words throughout his work. In the same review is noticed the late Dr. J. E. Taylor, Ph.D., F.L.S., on "The Sagacity and Morality of Plants."

STRAND MAGAZINE (London: September, 1897, 6d.) contains another of the series of articles by Mr. Grant Allen, entitled "Glimpses of Nature." The subject this month is Spiders, and the article is headed "Beasts of Prey." There are nine illustrations drawn by Mr. Fred Enock, showing "cocoon of young spiders hatching"; the same casting their first threads to catch the wind; the baby spider in its first snare; and the common garden spiders, with various portions of their anatomy much enlarged. The article is treated in Mr. Grant Allen's usual charming style for popular natural history. "For sheer ferocity and lust of blood," he says, "perhaps no creature on earth can equal that uncanny brute the common garden spider. She does not point a moral with the ant." There are careful descriptions of the manner in which the spider catches and eats the unwary flies, and also an interesting account of her method of changing her covering.





A FIRE broke out on September 12th, at the National Exhibition at Arnheim, in Holland. The main building and all the annexes, including the Physical Science Museum, were destroyed.

THE English Arborescent Society held its annual meeting this year at Lynn, in Norfolk. Among other arrangements, the members visited the Sandringham estate of the Prince of Wales.

ACETYLENE gas, which we referred to in SCIENCE-GOSSIP (vol. i., p. 278, N.S.) appears to be gaining favour as an illuminant. There are commercial demonstrations of it in London at the present time.

FIELD naturalists will be glad to learn that the unpublished journals of the great naturalist, Audubon, are being translated into English, and prepared for publication by his granddaughter.

THE ninth annual meeting of the Association of Economic Entomologists took place in August last, at Detroit, Michigan. Among the visitors were Dr. C. A. Dohrn and Professor E. B. Poulton.

IN his address, Professor Webster, the retiring President of the American Association of Economic Entomologists, severely criticised those people who multiply descriptions of "species" without sufficient care and material for examination.

DURING the opening service of the Hereford Musical Festival on Sunday, September 12th, a robin, undeterred by the loud rolling music of Mr. Elgar's *Te Deum*, warbled plaintively and repeatedly from its perch on a rafter in the roof of the cathedral.

THE "American Association for the Advancement of Science," the equivalent of our British Association, met this year, in August, at Detroit, the attendance was only 291 and some foreign visitors. Boston is to be the place of meeting next year.

CANADA is well to the fore this season. Without mentioning Klondyke, which is its great popular advertisement, the Dominion has seen two of the most important science meetings of the year, that of the British Association and also that of the British Medical Association.

THE Columbia University scientific expedition to Alaska has met with a terrible accident through shipwreck. Not only are all their apparatus lost, but also the collections and notes which were the results of their summer work. The members of the expedition, with other passengers, were only spared after seventeen hours' exposure in the lost ship's lifeboat.

SOME people may learn that by payment of a guinea or more they can be accommodated by an enterprising American agent, who has lately visited England, with a degree in either Science or Arts in the "Chicago National University." The only difficulty about the matter is that there does not appear to be any such institution which is entitled to confer degrees.

DR. R. BLANCHARD, the Secretary of the Zoological Society of France, has been appointed Professor of Natural History to the Faculty of Medicine of the University of Paris.

WE have received from Mr. Wilfred Mark Webb, F.L.S., the Editor of the "Journal of Malacology," a reprint of his article on "The Non-Marine Molluscs of Essex," which will be useful to students of the group.

WIRELESS telegraphy is receiving a careful trial at Dover in connection with developing a plan of communicating with lightships. The results so far are satisfactory; messages from Fort Burgoyne were read at the South Foreland lighthouse. The call was made by agitating an electric bell at the lighthouse with the wireless current. An induction-coil used produces a spark about thirty inches long.

DR. S. H. SCUDDER, the eminent American entomologist, has issued a new "Guide to the Genera and Classification of the North American Orthoptera," at the price of one dollar. It is a series of tables of the seven families into which the Orthoptera of North America is divided. Added are biographical notes and a list of books on the Orthoptera of that section of the American continent.

THE leading newspapers announce the return of the Duke of the Abruzzi (Prince Louis of Savoy) and his companions from their successful ascent of Mount St. Elias, on the Canadian border of Alaska. The mountain is found to be not volcanic in origin, but elevated sedimentary strata of fossiliferous character. The party passed fifty days among its ice and snow. The height of Mount St. Elias was found by Prince Louis to be 18,060 feet. This makes it, according to present measurements, the second highest mountain in North America; the Peak of Orizaba, in Mexico, being said to be about 100 feet higher.

SIR JOSEPH HOOKER, F.R.S., has just completed the gigantic work, entitled "The Flora of British India," upon which he has been closely engaged for upwards of a quarter of a century. Our readers will remember that as far back as 1848, Sir Joseph (then Dr.) Hooker undertook a lengthy journey to the Himalayas for the purpose of making botanical investigations. On his return to England he published two volumes of "Himalayan Journals," and also a larger work, entitled "Flora Indica." The work which he has just finished, however, is of an immensely more important character, as will be understood by the general index containing no fewer than 42,000 references.

DR. JOHN BRAXTON HICKS, M.D., F.R.C.P., Lond., F.R.S., F.L.S., etc., who recently died, was eminent alike as a medical man and a lover of natural science. Born at Milford, Hants, in 1823, his father was a banker and county magistrate of Hampshire, where the family had been land-owners for generations. Dr. Hicks was a frequent writer on medical and natural history subjects, often illustrating his papers with his own drawings. Some of his original research has been published by the Royal Society in its "Proceedings." Among other papers are "Eyes of the Invertebrata." He also contributed to the "Transactions" of the Linnean Society papers on botany and zoology, particularly original notes on lichens, mosses and unicellular algae. To the "Microscopical Journal" he sent papers on "*Volvox globator*," "Amoeboid Vegetable Bodies," and "Gonidia of Lichens." He practised for a considerable time in the neighbourhood of Tottenham, Middlesex.



CONTRIBUTED BY FLORA WINSTONE.

LA FEUILLE DES JEUNES NATURALISTES (Paris : September, 1897.) Dr. L. Géneau de Lamarlière concludes his "Synoptic Tables of the Family of Helvellaceae." In this number he treats of the genera *Gyromitra*, *Helvella*, *Verpa*, *Mitrella*, *Geoglossum*, *Leptoglossum*, *Spathularia*, *Vivissea*. There is also an index explanatory of the plates produced in the last number of this magazine. "Notes upon some Shells of Cerithiidae from the Eocene Stratum of Paris," by M. L. Vignal, are completed and accompanied by two plates containing thirty-six figures. The current article is chiefly on the genus *Potamides*. The animal in a fossil state does not bear much resemblance to specimens of the present day, and it has only been by careful examination and analogy of the forms and ornamentation of living species that these fossils have been placed in this genus. M. E. Simon continues his articles on the "Revision of the Genera of Trochilides," describing at length ten species. M. J. Jacquet contributes a note on the "Influence of Electricity upon Plants," being the result of some experiments he has lately tried. The results obtained have been very curious.

BULLETIN DE LA SOCIÉTÉ ZOOLOGIQUE DE FRANCE (Paris: July, 1897). M. Percy Selous writes "On the habits of the Ground Rattlesnake, *Sistrurus catenatus*, in Captivity." M. Selous's notes on these snakes are very interesting, as he has spent many years in studying their habits, having made pets of several specimens. He describes their mode of eating and drinking and habits of their young, of which he has reared about twelve. M. N. Kholodkovsky contributes a short note on a "Method of Preserving Actinies." He recommends a little sea-water mixed with a rather large quantity of formol at forty per cent. diluted in ten times its volume of fresh water. This solution, he says, will fix sea-anemones so quickly that they contract very little, sometimes not at all. He considers this method superior to that of the Brothers Hertwig, who used tobacco fumes. M. Maurice Pic adds a supplement to his series of articles on "The Coleoptera Phytophages," and also writes on "The Coleoptera Hétéromeres of Java and Sumatra."

COSMOS (Paris: September 18th). This number contains a series of editorial notes on auto-motor cars. This is an account of the postal motor-car established within the last few weeks between Paris and Beauvais under the auspices of the Compagnie du Nord. It is proposed by the same Company to shortly start a motor quadricycle for night service. A further note deals with experiments which have been tried towards using alcohol instead of petroleum as the driving-power of motor-cars. The following is from the table of the relative explosive powers of alcohol and petroleum. Petroleum, explosive power in air, 45'00; Alcohol, explosive power in air, 9'00. There is an article,

to be continued, on "Chemical Notation," signed by the initials, "A. G." The subject is divided in the present number into two parts (1) "The Formation and Notation of Equivalents," and (2) "Equivalents." The present system of nomenclature, usually known as the Lavoisier nomenclature, is carefully discussed, and it is suggested that a somewhat similar system of notation should be founded. M. W. de Fonvielle writes on the return of Dr. Jackson's Polar Expedition, giving a map of the explorations and the Polar regions generally.

AMERICAN JOURNAL OF SCIENCE (New Haven, Connecticut: September, 1897). Mr. O. C. Marsh contributes an article on the "Principal Characters of the Protoceratidae." It is illustrated by six beautiful plates of the male skulls of *Protoceras celer* (Miocene period), and one of a female skull of the same species at the same period. All known remains of Protoceras are from the Upper Miocene strata of South Dakota. "Electrical Discharges in Air," by John Trowbridge, and the following article on "The Oscillatory Discharges of a large Accumulator," by the same author, are analyses of the flaming electrical discharges in the air, and the similar oscillatory ones of a large accumulator. Professor L. Manouvrier, of the Paris School of Anthropology, writes on the vexed question of *Pithecanthropus erectus*. The article is on the discovery made by Mr. Eugene Dubois, a physician in the Dutch army, of some bones in the Tertiary strata near Trinil, Java. These bones have been said to belong to a being intermediate between man and the anthropoids. It will be remembered the discovery was made during a geological exploration to Java from 1890 to 1895, under the auspices of the Government of Holland. Dr. Dubois, who is a competent anatomist and geologist, went to the Indian archipelago in the hope of finding there, by means of the important excavations about to be undertaken, the famous Missing Link, which, according to accepted theories, should antedate Quaternary times. Professor Manouvrier carefully discusses both sides of the question, and gives comparative illustrations of the parts discovered, the same in human beings and in anthropoid apes.

PROCEEDINGS OF THE AMERICAN PHILOSOPHICAL SOCIETY (Philadelphia). This number contains an article by Edwin J. Houston, Ph.D., and A. E. Kennelly, Sc.D., on "The Insulating Medium surrounding a Conductor the real Path of its Current." It is amply illustrated by forty figures, and appears to contain some new ideas on this matter. Dr. J. Cheston Morris writes on "The Relation of the Pentagonal Dodecahedron found near Marietta, Ohio, to Shamanism." Mr. R. H. Mathews, L.S., has an article, well illustrated, on "Australian Rock Carvings." The remainder of the magazine, consisting of 106 pages, is occupied by an article on "The Geology of the Palaeozoic Area of Arkansas, South of the Novaculite Region," by George H. Ashley, Ph.D. There are several illustrations and the article is divided into sections.

LA NATURE (Paris: September 4th). M. J. Poisson writes of "The Old Acacia in the Museum." This remarkable tree, which is well known to visitors to the Jardin des Plantes, was planted in the reign of Louis XIII. by Vespasian Robin, then Demonstrator of Botany to the Jardin des Plantes. M. A. Rigaut describes "The use of Carbide of Calcium at Notre Dame de Briançon." The article is illustrated by five figures.



CONDUCTED BY FRANK C. DENNETT.

		Rises.		Sets.		Position at Noon.	
		h.m.	h.m.	h.m.	h.m.	R.A.	Dec.
Sun	Oct. 4	6.8 a.m.	5.30 p.m.	12.42	...	4° 34' S.	
	14	6.25	5.8	13.19	...	8° 21'	
	24	6.42	4.47	13.57	...	11° 57'	
		Rises.		Sets.		Position at Noon.	
		h.m.	h.m.	h.m.	h.m.	R.A.	Dec.
Moon	Oct. 4	3.9 p.m.	7.22 p.m.	11.46 p.m.	7	22 14	
	14	6.16	2.10 a.m.	10.48 a.m.	17	22 14	
	24	4.40 a.m.	10.16	3.36 p.m.	27	22 14	
		Souths.		Semi Diameter.		Position at Noon.	
		h.m.	h.m.	h.m.	h.m.	R.A.	Dec.
Mercury	Oct. 4	10.47 a.m.	5° 9'	11.41	...	3° 2' N.	
	14	7.50	5° 9'	12.22	...	0° 19' S.	
	24	11.10	5° 5'	13.23	...	7° 1 S.	
Venus	Oct. 4	9.52	6° 3'	10.46	...	9° 1' N.	
	14	9.57	6° 1'	11.32	...	4° 35' N.	
	24	10.4	5° 9'	12.17	...	0° 8' S.	
Mars	Oct. 14	0.30 p.m.	1° 9'	14.3	...	12° 21' S.	
	14	10.19 a.m.	14° 4'	11.52	...	2° 3' N.	
	14	2.13 p.m.	7° 2'	15.57	...	18° 7' S.	
Saturn	Oct. 14	2.6	1° 8'	15.39	...	19° 20' S.	
	14	3.56 a.m.	1° 2'	5.27	...	21° 51' N.	

MOON'S PHASES.

	h.m.		h.m.
1st Qr.	Oct. 3 ... 5.32 a.m.	Full	Oct. 10 ... 4.42 p.m.
3rd Qr.	" 18 ... 9.9 p.m.	New	" 25 ... 11.28 p.m.

In apogee, October 14th, 10 p.m., distant 252,100 miles; and in perigee on 27th, at 3 a.m., when its distance is 223,300 miles.

CONJUNCTIONS OF PLANETS WITH THE MOON:

Oct.	Planet	Time	Planet	Time
23	Jupiter*	9 p.m.	planet	5° 55' N.
24	Venus†	4 a.m.	"	6° 39'
25	Mercury†	1 p.m.	"	6° 57'
26	Mars†	3 p.m.	"	5° 12'
27	Saturn*	9 p.m.	"	6° 14'

\* Below English horizon. † Daylight. : Planet rising.

OCCULTATIONS AND NEAR APPROACH:

Oct.	Star.	Magni. tude.	Dis-appears. h.m.	Angle from Vertex.	Re-appears. h.m.	Angle from Vertex.
8	♋ Piscium	4.7	9.31 p.m.	32°	10.35 p.m.	264°
8	♈ Arietis	4.6	3.47 a.m.	131°	Near approach.	
17	♉ Tauri	3.8	11.59 p.m.	73°	1.6 a.m.	302°
14	♊	4.2	0.41 a.m.	129°	1.51 a.m.	225°
14	♈	3.0	1.25 a.m.	117°	2.47 a.m.	214°
14	♉	3.9	2.41 a.m.	118°	3.35 a.m.	171°
16	♊	4.9	5.47 a.m.	99°	6.51 a.m.	171°

THE SUN seems to be showing increased activity, several spots of considerable size being on the disc in the earlier part of August.

MERCURY is a morning star, reaching its greatest elongation west (17° 57') at 10 p.m. on October 7th, about which date it rises near 1h. 45m. before the sun, and so can well be observed. On the 6th he is in conjunction with Jupiter at 8 a.m., Jupiter being 12' S.

VENUS is also a morning star, rising 3h. 10m. before the sun on October 1st, and 2h. 28m. before on 31st. It is in conjunction with and 28' N. of Jupiter at 9 p.m. on 9th, unfortunately below our horizon.

JUPITER is a morning star, rising at 4.40 a.m. on October 1st, and at 3.16 on 31st.

MARS is too close to the sun for observation.

SATURN can only be seen directly after sunset, as it sets at 7.29 on the evening of October 1st, and at 5.38 on the 31st.

URANUS has passed from our view.

NEPTUNE is a morning star closely south-west of the Crab Nebula in Taurus.

METEORS may be looked for on October 13th, 15th, 17th, 18th, 22nd, 24th and 29th.

RED STARS IN POSITION DURING OCTOBER:

	R.A.	Dec.	Magnitude.
	h.m.	h.m.	
S. Cassiopeizæ	1.11	71° 59' N.	6.7<13 Variable
α (Mira) Ceti	2.14	3° 27' S.	2 9.5 Variable
— Piscium	1.10	25° 5' N. ±	7.5 Brilliant ruby
S. "	1.11	8° 10' N. ±	Variable
— "	1.15	6° 30' N. ±	

AMIDST the great double cluster in the sword-hand of Perseus, R.A. 2h. 10m. Dec. N. 56° 34', there are, according to the late Rev. T. W. Webb, no less than five red stars to be seen with a fair-sized telescope.

THE coming total eclipse, on January 22nd, 1898, will be best seen in India. On the coast near Bombay totality will last over two minutes. In the North-West Provinces, however, 100 seconds is all the time for observation. Sir J. Norman Lockyer and Mr. Fowler will be stationed near the Bombay coast. The Astronomer Royal (Professor Turner) and Dr. A. A. Common will be where the shadow track crosses either the southern Mahratta, or the Great Indian Peninsular Railway. Mr. Newall will go to Wardha by the railway from Bombay to Nagpur, and, using a large slit spectro-scope, will endeavour to discover the rate of rotation of the corona, by the relative displacement of the lines of the spectrum east and west of the sun. The shadow path across India has a length of about 1,000 miles, and a width of 50 miles.

THE CAPE OBSERVATORY.—Mr. Joseph Lunt, B.Sc., Director of the Photographic Section of the British Astronomical Association, has been appointed Assistant at the above observatory, to take charge of the telescope and spectroscope recently presented by Mr. McClean, for the purposes of stellar spectroscopy.

THE YERKES OBSERVATORY.—According to the "Observatory," the opening ceremonies are to occupy five days, October 18th to 22nd. On the 22nd, Mr. Yerkes will formally present, and the President of Chicago University accept, the Observatory.

GRESHAM COLLEGE LECTURES.—Courses of Lectures on Astronomy and other subjects, free to all, and frequently illustrated by limelight, are given autumn, winter and spring, at the College in Gresham Street, E.C., and are much appreciated. The lectures were first given in 1597, so that this year is the Tercentenary. This being so, on November 2nd, 3rd, 4th and 5th, at 6 p.m., Rev. Professor E. Ledger will lecture on "The Astronomy of the time of Queen Elizabeth, compared with that of the time of Queen Victoria."

MARS AND VENUS.—The measures of Mars made by Prof. E. E. Barnard with the 36-inch Lick Telescope in 1894, give the equatorial diameter of 4,352 miles; the polar diameter being 4,312 miles. In 1895, with the same instrument, Venus was measured as 7,626 miles.

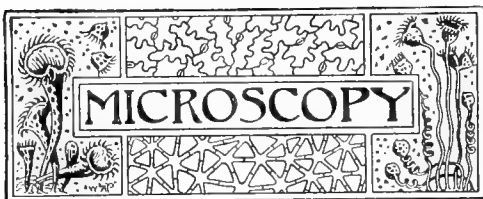

CONDUCTED BY J. H. COOKE, F.L.S., F.G.S.

To whom Notes, Articles and material relating to Microscopy, and intended for SCIENCE-GOSSIP, are, in the first instance, to be sent, addressed "J. H. Cooke, Thorndale, Lincoln."

**DISCOLOURATION OF FLOWERS.**—The discolouration of flowers and algae on drying is attributed to atmospheric ammonia. To counteract its injurious effect, Nienhaus has used pressing-paper previously saturated with a one per cent. oxalic acid solution, and dried, obtaining in this way beautiful specimens of some of the most difficult flowers to preserve, unchanged.

**EGGS OF INSECTS AS OBJECTS FOR THE MICROSCOPE.**—The collection, preservation and examination of the eggs of insects will afford the microscopist many an hour's interesting recreation. Curtains, carpets, floor-crevices, cushions, furs and woollen garments will serve as a prolific hunting-ground indoors; while out of doors the surface-waters of ponds and water-butts, the crops of birds, the skins of cattle, and the leaves and branches of the shrubberies will give an abundance of material. Among those insects whose eggs make the most interesting microscopical mounts may be noted the common house-fly, the wasp, the tortoise-shell and the cabbage butterflies, the mottled umber and the puss moths, the dragon-fly, and most of the parasites. The eggs of these are of all shapes, hexagonal, conical, oval, spherical, and are most richly and harmoniously coloured; while the elaborately sculptured surfaces are hardly excelled in the beauty of their designs by the symmetry of the ciliated, winged and fringed ornamentations with which they are surrounded.

**ENEMIES OF OYSTERS.**—The sudden disappearance of oysters from places where they were formerly numerous may be, in part, explained by a recent remarkable visitation in the harbour of Sydney, New South Wales. The water, in places, suddenly assumed the colour of blood. This proved to be due to the invasion or rapid development of a microscopic *Glenodium*, which, in a few days, destroyed half of the animals near the land, and seriously injured the oyster-beds.

**THE LIFE-HISTORY OF AN APHIS.**—In "The Strand Magazine" Mr. Grant Allen has contributed an interesting article on this curious insect. Rose-growers and microscopists are equally its enemies, but they are the least of the legion that she has. From within and from without she is ceaselessly being attacked by a host of belligerents. The most destructive of these are no doubt the lady-birds, which, both in their larval and in their winged form, live almost entirely on various kinds of green-fly. This practical fact in natural history is well-known to the hop-growers, for the dreaded "fly" on hops is an aphis; its abundance or otherwise governs the hop market, and Kentish farmers are keenly aware that certain particular lady-birds eat the "fly" by millions, on which account they protect and foster this ladybird, thus leaving the two insects to fight it out in their own way between

them. But the aphis has a still more insidious though less dangerous foe—an international parasite which lays its eggs inside the body of the bud-producing female. Then the grub hatches out, and proceeds to eat up its unwilling hostess, alive, from within. The lodger after eating his hostess out eats himself out into the open air through her empty skin. If you look out closely for such haunted green-flies inhabited by a parasite, most often an ichneumon fly, you will find them in abundance on the twigs of rose-bushes. They have a peculiar swollen, quiescent look and a brownish colour. Another enemy who attacks the aphis with the ferocity of a tiger is the larva of the wasp-fly. It is a savage carnivore, who moors himself by his tail-end, stretches out to his full length and swoops down on his unsuspecting prey from above, and, being blessed with a good appetite, he can get rid of no fewer than 120 aphides in an hour. It is estimated that he can manage to dispose of about 15,000 or 16,000 victims at a sitting.

**A HINT.**—Glycerine is one of the most useful of mounting mediums, but a difficulty is usually experienced with it when ringing. This may be overcome by using gum damar dissolved in benzoline instead of the usual gold-size.

**MICROSCOPICAL STUDIES.**—In reply to several correspondents who have asked for information relative to the issue of a series of microscopical studies, accompanied with text, we regret to say we can give no assistance at present. In the eighties, Mr. J. D. Ady issued a series of petrological studies, with text and plates, and in biology the "Popular Microscopical Studies" of Cole left nothing to be desired. If these or any similar ones are still being issued, we shall, on behalf of our readers, be glad to hear of them.

**COLOUR-REACTION.**—Nylander was one of the first to call the attention of biologists to the value of colour-reaction in the study of the lichens. The three principal re-agents used by microscopists are, (1) iodine to give blue reactions; (2) hypochlorite of lime to give red reactions, and (3) hydrate of potash to give yellow reactions. Iodine possesses the property of turning starch and amyloid bodies blue, and so is generally applied to sections of the apothecia, when the asci are transformed from their plain semi-transparency to a delicate blue, thus rendering them at once visible, and their forms and positions may be easily ascertained. The lime and potash tests are generally used on the thallus or leaf-like portion of the lichen, sometimes on the surface only, and at others on the medullary layer.

**MOUNTING MEDIUM.**—The following method of making an adhesive material for labels on glass, or for fastening opaque objects for the microscope, is given in the current number of the "Journal of the Microscopical Society." Take 120 grains of gum arabic and dissolve it in a quarter of a litre of water. Dissolve thirty grains of powdered gum tragacanth in a similar quantity of water. After a few hours, shake the latter solution until it froths, and mix with the former. Strain the mixture through linen, and afterwards add to it 150 grams of glycerine, previously mixed with 2½ grams of oil of thyme.

**LIFE-HISTORY OF THE FLEA.**—Professor Duncan, F.R.S., gives us some interesting details bearing on the life-history of that troublesome, though, to the

microscopist, very interesting pest, the flea. Fleas lay their eggs in cracks, in cushions and in boards, or in the midst of dust; and their larvæ, which have no legs and which therefore must live where they have been born, can only exist in consequence of the nourishment brought to them by adults. Were they abandoned they would perish, but they have excellent mothers who never leave them; for after a flea, should it be a mother, has gorged itself with blood, it seeks its young and disgorges a small quantity so as to keep them alive. The larvæ shut themselves up in silken cocoons when they have attained their full size, and undergo their metamorphosis into the condition of nymphs.

**MOSQUITOES.**—Our readers will, probably, have noticed the great prevalence of mosquitoes this summer, but familiar though they may be with the methods of its attack, few have any idea of the complicated apparatus with which this fly works its mischief. The beak of the mosquito is simply a tool-box wherein the mosquito keeps six miniature surgical instruments in perfect working order. Two of these instruments are exact counterparts of the surgeon's lance, one is a spear with a double-barbed head, the fourth is a needle of exquisite fineness, a saw and a pump going to make up the complement. The spear is the largest of the six tools, and is used for making the initial puncture; next the lances or knives are brought into play to cause the blood to flow more freely. In case this last operation fails of having the desired effect, the saw and the needle are carefully and feelingly inserted in a lateral direction in the victim's flesh. The pump, the most delicate of all six of the instruments is used in transferring the blood to the insect's stomach.

**THE HEN FLEA.**—This parasite has a wide zoographical distribution, a fact that is due to its being carried from one locality to another by birds. Mr A S Packard illustrates in "Insect Life" some specimens that were obtained from an owl (see fig. 1), representing the male, with the antennæ and palpi enlarged. Dr. Julius Wagner, of the Zoological Laboratory, Imperial University of St. Petersburg, is giving much attention to the Siphonaptera, and is desirous of obtaining specimens from here or abroad.

**REPRODUCTION OF MARINE DIATOMS.**—In the "Proceedings of the Royal Society of Edinburgh," Mr G. Murray records some remarkable observations on the mode of propagation of certain pelagic diatoms collected off the coast of Scotland, chiefly belonging to the genera *Biddulphia*, *Coscinodiscus*, and *Chaetoceros*. In *Biddulphia m. obtusius*, "cysts" were observed within the parent cell, with only slightly silicified membrane, and destitute of the characteristic spines. These cysts appear to have the power of dividing and multiplying before assuming the characteristic parent form. A similar phenomenon was observed in *Coscinodiscus*

*concinuus*, but in this species the protoplasm divides before the production of the "cysts," two of which were found within the same parent frustule, differing from one another in form and in the width of the girdle-zone. It is not uncommon to find the young colonies of *Coscinodiscus* in "packets" of eight or sixteen, this being apparently the result of further binary division within the frustules, which are found accompanying them in an empty state. The membranes of these young colonies are only very slightly silicified, or not at all; and they are, therefore, capable of increasing in size. A similar formation of "packets" of eight or sixteen young individuals within the parent frustules was observed in several species of *Chaetoceros*.

**PRESERVATION OF ALGAE.**—The following method for the preservation of the colours of freshwater algae and desmids will be found to be most effective. Place the algae in a watch-glass in camphor-water to which a few drops of glycerine have been added. At first it will become a yellow colour, but after a few hours the original green returns in its full vividness. It should then be mounted in a cell with a portion of the fluid. A specimen of *Draparnaldia plumosa* mounted twenty years ago in this way is today as beautifully green as at first, and the chlorophyll seems to be unchanged.

**MANCHESTER MICROSCOPICAL SOCIETY.**—At the Annual Soiree of the Manchester Microscopical Society, which is to be held in the Athenæum on October 2nd, Mr. F. W. Keeble, of Owens College, Manchester, will deliver a lecture entitled "Impressions of Tropical Life."

**BACTERIUM LIVING IN ALCOHOL.**—From

"Natural Science" we learn that Mr. and Mrs. Victor H. Veley, of Oxford, have recently discovered a micro-organism in some faulty rum that had been sent to them for examination. For some time past the colony of Demerara has suffered considerable monetary loss owing to the unaccountable manner in which the rum that it exported depreciated in quality. The depreciation has now been traced to the presence of a bacterium which belongs to the group Coccaceæ. The fact of any micro-organism existing and multiplying in spirit correctly assessed at 42° over proof, or about 74.6 per cent. by weight, is of great interest both from a scientific and technical point of view.

**ANSWERS TO CORRESPONDENTS.**—Major-General E. Warrand, of Westhorpe Hall, Southwell, desires to know of good localities for collecting microscopic material in the vicinity of Southwell or Lincoln. There are no better collecting-grounds in the kingdom than the pools, drains and marshes that lie within a mile radius of Lincoln Stonebow. Of Southwell I can give no information, but perhaps some of our readers will kindly assist Major-General Warrand.

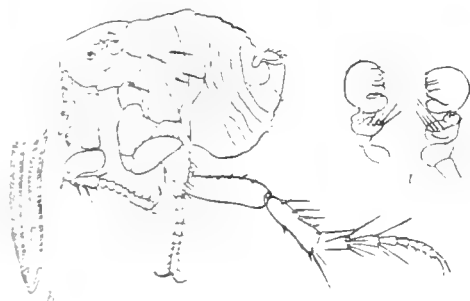

FLEA FROM OWL.

*Sarcopsylla gallinacea*: male, enlarged; a, antennæ; b, palpi, more enlarged.

(From drawings by Packard.)

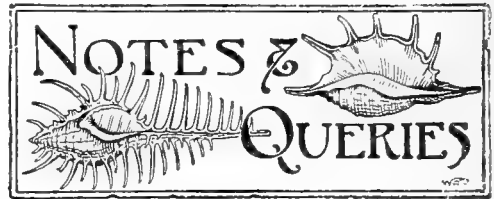
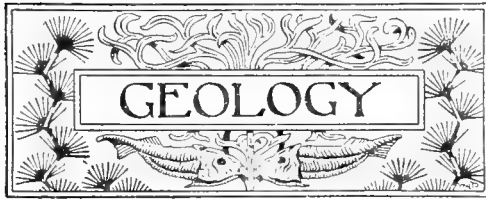

**CHALK—CROYDON TO OXTED.**—In Mr. Caleb Evans' article on the Croydon and Oxted Chalk, published in the proceedings of the Geologists' Association, January, 1870, he divided the chalk into seven beds, as: Purley Beds, containing *Inoceramus cuvieri* and *Micraster cor-testudinarium*; Upper Kenley Beds, containing *M. cor-testudinarium* in the upper part, and *Ananchytes ovatus* and *Spondylus spinosus* in the lower; Lower Kenley Beds, with *Holaster planus* and *M. cor-bovis*; Whiteleaf Beds, with *I. brongiarti* and *Galerites sub-rotundus*; Upper Marden Beds, with *Ammonites peramplus* and *I. mytiloides*; Lower Marden Beds, with *A. varians* and *Belemnitella plena*. Having worked these beds the last four years, I think a few notes on them might be useful. At Purley, as Mr. Caleb Evans says, *M. cor-anguinum* is rare, and *M. cor-testudinarium* is most abundant; at the bottom of the quarry *A. ovatus* is very plentiful. The Kenley chalk is very plentiful in fossils, especially *Micraster*, *Ananchyte*, *Inoceramus*, and *Tevebratula*. At the Rose and Crown Pit, in that valley, there is a bed of marl which divides the Upper Chalk from the Lower, and it runs down the valley for over a mile and re-appears at Whiteleaf. The bed is full of phosphatic nodules and *Tevebratula gracialis*. At Marden Park there are no quarries; but at Caterham, which is on the same zone, are *I. mytiloides*, *G. sub-rotundus* and *Rhynchonella plicatilis*. In comparison with Mr. Caleb Evans' list, the following are additional. At Purley, *Doryderma ramosum*, *Cliona*, *Pecten cretosus*, *Psychochus altior*. At Kenley, *Ventriculites impressus*, *I. involutus*, *Pecten fissicosta*, *Lima granosa*, *L. semisulcata*, *Ostrea simplana*, *Modiola quadrata*, *Corax falcatus*. At Whiteleaf, *Psychochus latissimus*, *P. manmillaris*, *Tevebella levisensis*.—*G. Fletcher Brown*, 252, Whitehorse Lane, S.E.

**GREENLAND CRETACEOUS FLORA.**—In northern Greenland some beds of clay of Cretaceous age have been found which contain plants, showing that at one time there was a warm, almost a sub-tropical climate within twenty degrees of the Pole. This is where there is now eternal ice almost in sight, and where any plant more than a few inches in height is a somewhat remarkable feature in the landscape. From these beds, 335 different kinds of plants have been disinterred, amongst them being the cinnamon and fig, the magnolia and the oak, together with such familiar ones as beeches, guelder-roses and maples. The extraordinary thing in connection with these, at one time Arctic plants, is that if the earth has always turned round the sun, and round itself, with an inclined axis, as now, these trees and plants must have been completely in darkness for a third of the year. Astronomers will not have it that the earth has in any way changed its axis. Yet it does not seem possible that the plants mentioned all lived in darkness throughout so long a time. This is a case in which astronomical and botanical doctors differ. Who shall decide?—*Edward A. Martin*, F.G.S., 69, Bensham Manor Road, Thornton Heath.

**ORIGINAL RESEARCH.**—Can any one propose any subject for original research, especially in breeding or keeping any mollusca, mammals, or lower forms of life? Or is any one working at any zoological subject who would be glad of a fellow worker?—(Rev.) *H. A. Soames, F.L.S., The Hawthorns, Otford, Sevenoaks*. [If no one has a better suggestion, the investigation of the causes of band-variation in *Helix nemoralis* and *H. hortensis* offers a good subject.—*Ed. S.-G.*]

**SPIRULA PERONII IN DEVONSHIRE.**—In addition to Mr. J. E. Cooper's note on "The Marine Mollusca of North Devon" (*ante* p. 85), I may say that Mrs. Willsher, Netly, Ilfracombe, an ardent collector, found two perfect *Spirula peronii* (Lam.) on Barricane beach. The nearest possible point for these shells that I know is Jamaica. The interesting point is that so frail a shell should have travelled so far uninjured. According to the chart of ocean currents (Geikie, *Phys. Geo.*, plate viii), Jamaica lies in the track of the Gulf Stream.—*R. Ashington Bullen, F.G.S., Loughrigg, Reigate; September, 1897.*

**HELIX ARBUSTORUM, SUB-FOSSIL.**—At Harlton, Cambs., the Rev. Osmond Fisher, M.A., F.G.S., pointed out to me the occurrence in abundance of *H. arbustorum* in a sub-fossil condition. Some examples are almost as fresh as recent specimens. Mr. Fisher has only found, in the same district, one living specimen in thirty years. I looked for them carefully in damp spots, but only secured two immature specimens which were making shell in May last. They were on an ait on the Cam, near Sheep's Green.—*R. Ashington Bullen, F.G.S.*

**TELLINA RADIATA IN IRELAND.**—I have to report a West Indian shell, *Tellina radiata* (Linn.), from Courtmacsherry beach, south-west coast of Ireland. The clergyman's niece, who found the specimen in my possession quite recently, found a larger one at Youghal previously, and was unacquainted with its sub-tropical character.—*R. Ashington Bullen, F.G.S.*

**PALUDESTRINA ULVAE, VARIETIES.**—Recently at Lowestoft, on the shores of Lake Lothing, I found an abundance of *Paludestrina ulvae* (Pennant), of a rich brown colour. The grey-green variety which Col. Fielden presented to the British Museum, from Norfolk, occurs sparingly. *Littorina rudis* and vars. *tenebrosa* and *saxatilis* also occur abundantly near the same spot.—*R. Ashington Bullen, F.G.S.*

**RABBIT HUNTED BY A CAT.**—While walking through a wood near Ulverston, in June last, I noticed a rabbit running along the road towards me, looking frightened and evidently pursued by an animal which I saw at some distance behind. The rabbit did not appear to see me until I was within a few yards of it, when it suddenly stopped and bolted into the wood. The pursuer continued to follow, also without noticing my presence until it was within twenty yards of the place where I stood, when it also stopped suddenly and ran away.

I now saw that it was an ordinary domestic cat, which was evidently hunting the rabbit by scent. This occurrence was quite new to me. I have seen a rabbit hunted in this manner by a stoat, an occurrence which has often been noticed, but I was not aware that a cat would act in the same manner. Domestic cats often stray into woods, and are very destructive to game, but I did not know that they could hunt hares or rabbits by scent. — R. H. Meade, F.R.C.S., Mount Royd, Bradford; September 1st, 1897.

**MATERNAL INSTINCT OF SPIDER.**—In Kirby and Spence's "Entomology," mention is made of a spider, *Lycosa saccula*, which is maternally attached to a bag of eggs which it carries about with it, protecting them with great care. It is said it will fight to the death rather than lose these eggs. To satisfy myself of the accuracy of this statement, I made the following experiment with a specimen of this species which I had recently procured. Having rid her of the bag of eggs, I fixed them with a pin to a piece of cork attached to my greenhouse, and then watched with extreme interest the spider's endeavours to get the eggs away from their fixed situation on the cork. Having tried in vain for some time, she devised a means which I have not seen recorded before respecting this species. Some few inches away from the cork a plant of Virginia creeper grew, and from one or the leaves to the bag of eggs she spun several threads, all coming to a point at this attachment to the bag of eggs on the cork. Very soon after spinning these threads I found she had succeeded in detaching the eggs and had made her escape, leaving no trace behind. As to the actual way in which the web was used to detach the eggs I cannot with certainty say. That the web was made to enable her to obtain greater power in removing the eggs I have very little doubt; I should think that the wind acting on the leaf would cause it to oscillate, which would put a greater strain on the threads and would probably be the means of pulling the eggs from their situation on the cork. I shall be pleased to hear if any other reader of SCIENCE-GOSSIP has witnessed any form of this peculiar trait of this species.—F. W. Smith, 12, King Street, Camden Town, N.W.; September 13th, 1897.

**NATTER'S BAT IN CO. DOWN.**—In the last week of June of the present year I captured, in Aghaderg Glebe House, co. Down, a male, reddish-grey bat of the species known as *Vespertilio nattereri*. It was found flying about a bedroom, where, unlike either of our common bats, it made considerable noise in flying, and knocked down some small articles. When I had it in my hand I noticed its light colour and that its squeaks were louder than those emitted by other bats I have met with. The specimen was sent to Mr. J. Ray Hardy, of the Manchester Museum, Owens College, who kindly identified it and sent me several excellent photographs of it in various postures, and he has, I understand, preserved it. This animal is scarce, though widely distributed. It has not previously been mentioned, so far as I am aware, as found in this county.—H. W. Lett, Aghaderg Glebe, Loughbrickland, co. Down.; September, 1897.

**HABITS OF BUTTERFLY MOTH.**—Can any reader interested in entomology give me any information as to the very common buff-tip moth (*Pygocera bucephala*)? I have had exceptional chances of observing the larvae of this insect during the

present season, as, in this neighbourhood (Newark-on-Trent, Notts) they have been so abundant as to cause a very considerable havoc among the lime-trees. Especially is this noticeable among some fine young trees recently planted by the Newark Corporation on each side of the entrance to the town by the Great North Road, so familiar to cyclists. Trees of a larger growth attacked by the larvae (I am writing of the lime, for the elm does not abound just round here) have presented this year an unusually early autumnal appearance, and I fancy this must be due to the persistent sapping of the healthy leaves. The curious part is that the creatures are super-abundant, but they appear at the present moment (September 6th, 1897) in all stages of development, from first skin to last. Surely this is exceptional, for I read in my Newman, "the caterpillars are full fed towards the end of July." Another point is, that notwithstanding the amount of larvae, I have not once taken the perfect insect, although I have searched in places I know to be its favourite haunts. The only specimens I have hatched out about the middle of May from some last year's pupae. I apologize for the length of this note, my only excuse is that in the search for rarities our commonest friends in the entomological world get completely overlooked, and, although I show my ignorance, I should like to have the advantage of the opinion of an expert through your valuable columns on the reasons: (1) as to the marked variation in larval development; (2) the apparent scarcity of the perfect insect at the proper season.—Herbert A. Hole, Newark-upon-Trent.

**BADGER IN SUSSEX.**—A male badger (*Meles taxus*) was taken at Lordings, Billingshurst, seven miles south-west of Horsham, on June 22nd last, and is being preserved by Mr. A. Richardson, of Park Street, Horsham. The badger is now of very rare occurrence in this district.—Chas. J. Marten, 30, London Road, Horsham.

**SWINEY LECTURES ON GEOLOGY.**—A course of twelve lectures on the "Geological History of Invertebrate Animals," will be delivered by Dr. R. H. Traquair, M.D., LL.D., F.R.S., in the Lecture Theatre of the South Kensington Museum, on Mondays, Wednesdays and Fridays, at 5 p.m., beginning Monday, October 4th, and ending on the 29th of that month. These lectures, which are to be illustrated by lantern slides, are free of admission to the course. It will be observed that the site of these lectures has been removed from the Natural History Museum to the South Kensington Museum. The course is under the direction of the trustees of the British Museum, and should prove valuable to biologists as well as to geologists.

**SLUGS.**—In reply to Mr. A. J. Taylor (*ante* 123), the genera *Veronicella* and *Vaginula* are now considered synonymous. The descriptions of the species are scattered in different books and periodicals. The best authority on British Slugs is Mr. W. Denison Roebuck, 259, Hyde Park Road, Leeds; and for foreign slugs, Professor H. Simroth, Leipzigerstrasse, 1, Gohlis, Leipzig, Germany. The error in spelling the above genera occurred through our not seeing proof until too late to correct, and from the peculiar shape of the letters in our correspondent's writing.

**SLUGS.**—I shall be pleased to correspond with Mr. A. T. Taylor or others on the study of slugs. W. L. W. Eyre, St. Martin Rectory, Aylesford.





Referee: THE REV. E. ADRIAN WOODRUFFE-PEACOCK, L.T.H.,  
F.L.S., F.G.S., CADNEY, BRIGG.

**DOUBLE FLOWERS.**—Specimens of plants with double flowers and variegated leaves are constantly being sent in to me for record or figuring in this journal. I regret to say I can do neither as a rule. These anomalies are too common and of insufficient scientific interest. Albanism is merely a diseased state of the chlorophyll; and ordinary double flowers a petaloid growth of the anther stalk. There are, however, rare cases of peloriation which must not be classed in the same category as ordinary double flowers. A few years ago I received from Miss S. Allett, of Bath, a specimen of *Habenaria conopsea*, Benth., with three spurs on each plant of more than normal length. This looks like a reversion to some lost type, and such specimens are worthy of a much closer study than they can possibly receive at the hands of a general botanist. This specimen is preserved in the Lincolnshire County Herbarium. White-flowered species and anomalous forms have been carefully collected into this herbarium for a number of years, and demonstrate how common these abnormal changes are.—E. Adrian Woodruffe-Peacock; September, 1897.

**XENODOCHUS CARBONARIA IN WALES.**—I have found in Mid-Wales a good many leaves of burnet with *Xenodochus carbonaria*. If it is a sufficiently rare fungus to make it worth while, I shall be happy to send a leaf or two to anyone who will send a stamped envelope.—J. W. Walker, 2, Stanley Road, Watford; July 17th, 1897.

**ADAPTABILITY OF PLANTS.**—I have lately met with two good instances of adaptation to circumstances by plants. The first case was that of a hazel branch, which in the course of its growth met with an obstruction in the form of the ridge of a roof of a building. The branch, instead of turning aside, put forth a large excrescence, which on the under-side completely fitted itself to the ridge. In the second case, three onions, growing next one another, encountered some pieces of broken glass, and being unable to push them out of the way, grew round them and enclosed them within themselves.—Chas. J. Marten, 30, London Road, Horsham.

**BLADDERWORT.**—This interesting plant (*Utricularia vulgaris*) occurs in a small, clear ditch by the side of the Thames, between Maidenhead and Cookham. The very conspicuous bright yellow flowers, by the irregular shape of the corolla almost suggesting those of some papilionaceous plant, grow on upright peduncles rising two or three inches above the surface of the water. At first sight the submerged portion of the plant, when taken from the water, has the appearance of being covered with little water-snail shells. The apparent snails are really the older and darker of the bladders, with which the leaves are abundantly furnished. The date of the find was July 18th. I am informed that the plant also occurs at Burnham Beeches, about five miles from Maidenhead.—F. P. Pevks, 41, St. Martin's Lane, W.C.



**IMMENSE METEORIC STONE.**—Lieutenant Peary has succeeded in bringing from Greenland the meteoric stone found by him there. It weighs about eighty tons. This is believed to be the largest in the world.

**WATERSPOUT OFF CROMER.**—The unusual phenomenon of a waterspout was observed off the Norfolk coast on September 4th. A sketch of the storm was obtained by Mr. S. T. Dadd, an artist staying at Mundesley, which was reproduced in the "Graphic" of September 12th. Writing from Newhaven Court, near Cromer, Sir William Flower, K.C.B., F.R.S., said: "It was estimated to be about eight miles from the shore and travelled rather quickly from west to east. It consisted of two portions, a cloud with a narrow stem which rose from the sea, and long conical projection from the edge of a dense black cloud. The projection terminated in a point, which, though the descending column writhed and twisted about like an elephant's trunk, being sometimes longer and sometimes shorter, always pointed to the centre of the ascending cloud; but the two never appeared to mingle. The phenomenon was observed for half an hour, when, moving further out to sea, was finally lost to sight."

**WEATHER SIGNS AT WHITBY.**—While staying recently near Whitby, I observed some rather unusual phenomena which may perhaps interest your readers. On the evening of Tuesday, August 3rd, about 7.30, I noticed numerous rays of light emanating from a spot in exact opposition to the sun, about 10° above the eastern horizon, very similar in appearance to the rays commonly seen proceeding direct from the sun when the latter is hidden behind a cloud, but in this case no such rays were visible. At the same time there was, very clearly defined, what is locally known as "a ship in the sky," that is, long strips of cirro-cumulus clouds stretching right across the sky, converging at either end like the planks in the hull of a ship. According to the popularly weather-wise, if this ship is apparently sailing in the direction of the wind it indicates fine weather, but if the wind blows broadside to the ship it is held to be a certain sign of a storm within forty-eight hours. In this instance the wind was blowing broadside to the ship. There was no other sign of rain, the barometer being high and steady; but twenty-four hours afterwards a gale was blowing, and the following day we had a thunderstorm. Eleven days later another "ship" appeared, likewise broadside to the wind, and this was also followed by a storm within forty-eight hours. The morning of August 4th was brilliant, but a white mist was floating on the hill-side between Haggit Howe and Whitby. Upon this mist a beautiful white bow appeared about 7.45. It was similar to a lunar rainbow, but without the faintest trace of colour. The arc was perfect and continued visible till the mist gradually melted away before the advancing sun.—G. Creswell Turner, F.L.S., Parkhurst, Upper New Walk, Leicester; August 24th.





THE SOUTH LONDON ENTOMOLOGICAL AND NATURAL HISTORY SOCIETY.—July 22nd, Mr. A. W. Dennis in the chair. Mr. Ashdown exhibited a living specimen of the rare and local longicorn beetle, *Oberia oculata*, taken at Wicken Fen. Mr. Kedgely sent for exhibition, a specimen of the dragonfly, *Aeschna cyanea*, which had been taken in the Borough, London, on July 18th.—August 12th, Mr. R. Adkin, F.E.S., President, in the chair. Mr. McArthur, a fine bred series of *Toxocampa cracca* from North Devon. Mr. Edwards, young larva of *Callimorpha hera*, which he had just received from the French Alps, where the imagines absolutely swarmed. Mr. J. N. Smith, on behalf of Mr. Fitzgerald, a remarkably smoky variety of *Melanippe montanata*, one of a pair taken at the same time and place. Mr. Tolhurst, the curious telescopic larvae of *Eristalis tenax*, from a tank of foul water in his garden. Mr. West, of Greenwich, specimens of the hemipteron *Atractotomus mali* which he had taken on a white thorn at Lewisham. Mr. Ficklin, larvae of *Dianthaccia nana* from the Land's End. Mr. South, two bred specimens of *Peronia ferutana* from Eastbourne, which differed very considerably from the Wallasey type. Mr. Adkin, a small brood of *Abraxas grossulariata*, which exhibited none of the peculiarities of the female which deposited the ova. Mr. Harrison, a specimen of the rare liliaceous plant, *Simethis bicolor* from Greenwich marshes, Bournemouth and Derrylane being the only previously recorded localities.—August 26th, Mr. R. Adkin, F.E.S., President, in the chair. Mr. Tutt, the egg of *Polyommatus corydon*, which had never been previously described, and remarked on its beautiful reticulated appearance; a living mantis, from Aixles-Bains, which had fed ravenously on cockroaches, a tipula, with beautifully marked wings; and specimens of an orthopteron, which were abundant and active on the wing about 9 a.m. near Susa, and remarked on its protective colouration. On behalf of Mr. Tuck, of Bury St. Edmunds, he also exhibited a nest of *Vespa rufa* which had been attacked by the larvae of *Aphomia sociella*, and which was found about a foot deep in a bank; part of the nest of *Bombus lapidarius*, attacked by the same species and which had been taken from a rat's hole in a pigstye; and further, a nest of *Bombus latreillellus*, similarly attacked, found in a mouse's hole in a pasture. They were all taken during the few previous days. Mr. Adkin, series of *Bryophila muralis (landifera)*, and *B. perla* from Poole, with series from Eastbourne for comparison. Mr. McArthur, specimens of *Larotia salicuta* from North Devon, small and dark compared with those from other localities. A second brood specimen of *Smerinthus f. pua*, and a series of good varieties of *Atracta grossulariata* bred by him this season.—September 9th, 1897. Mr. R. Adkin, F.E.S., President, in the chair. Mr. Spindler exhibited a remarkable variety of *Epinephala tibialis*, in which the whole of the black markings were absent, while the fulvous colour was of the normal depth. It was taken at Lurgashall, Sussex. Mr. South,

several unusually dark Scotch forms of *Spilosoma menthastri*, being second generation descendants of Moray parents. Mr. Turner, an unusually grey specimen of *Mamestra abjecta*, taken in the Greenwich marshes; a small red form of *Agrotis tritici*, from Woolmer Forest, Hants; series of undersides of *Enodia hyperanthus*, from Carlisle and Chattenden, to show the contrast in the ground-colour, the former being of a grey appearance, while the latter were deep and rich; a larva of *Heterogenea limacodes* from Westerham; and larvae of *Acidalia immorata* from Alpine ova. He remarked upon the undoubted *Acidalia*-like habits and appearance, and said that they fed readily upon knot-grass. Mr. Manger, specimens of the largest known landshell, *Achatina variegata*, from Ibadan, near Lagos, west coast of Africa; these measured six inches across the mouth, and he said specimens were known to measure even eight inches. Mr. West, of Greenwich, specimens of the local Hemipteron, *Dictynota fuliginosa*, taken on broom at Plumstead. Mr. Adkin, series of *Satyrops semele*, from Eastbourne and Bournemouth, for comparison, with examples set to show their natural resting positions on the ground. Mr. Tutt remarked that allied continental species had precisely the same habits. Mr. Lucas, specimens and drawings of the scarce dragonfly, *Agrion mercuriale*, which he had taken in the New Forest this season. Mr. Dennis, under the microscope, ova of both *Polyommatus corydon* and *P. aegon*, the former of which he said had not yet been described. Mr. Tutt, a cabinet-drawer containing his series of *Erebia nevine* and its near allies, together with photographs of the famous Mendelstrasse, in illustration of his paper which he then read, entitled "A Gregarious Butterfly, *Erebia nevine*: a Reminiscence of the Mendelstrasse, with Notes on the Lepidoptera of the Serpents of the Mendelstrasse."—Hy. J. Turner, Hon. Report Secretary.

WOOLHOPE NATURALISTS' FIELD CLUB.—On Friday, August 27th, a large party attended the fourth field meeting to visit the Forest of Wyre, the town of Bewdley, Ribbesford Church, and the extensive caves historically used as a hermitage in the sandstone rocks opposite Ribbesford. Mr. Carleton Rea, of the Worcestershire Naturalists' Society, met the members at Wyre Forest Station, and conducted them on the northern side of the railway by a footpath in the forest skirting Dowles' brook for the distance of about three miles, when the brook was crossed, and the ascent of the hill was made to the railway line, which was crossed in order to reach the Great Bog. Here a halt was made, and a few bog plants were found. To view the locality in its glory the month of June should have been chosen, when it displays a mass of the fragrant *Habenaria conopsea*, *Epipactis palustris*, the delicate pink-coloured bog pimpernel (*Anagallis tenella*), cotton grass (*Eriophorum*), and other plants. Some specimens of *Chara* were gathered for examination under the microscope, of the streaming of protoplasm within the internodes with their enclosed enormous cells. The Great Bog may have originally deserved its name, but it is now of small area, and its character has most probably been altered by drainage from the neighbouring railway line. Leaving the Great Bog, the railway was again crossed, and the walk was continued along the Dowles' Brook unto its confluence with the Severn. A pleasant walk along the banks of the river conducted to Bewdley. Mr. Rea gathered on the banks of the Severn a specimen of *Cononilla* in flower. This papilionaceous plant has

become naturalized in this locality, Mr. Rea stating that it had been known there for at least a century. The American water-weed, *Anacharis alinastrum*, was observed in the Severn. Wyre Forest is well known to the Worcestershire naturalists as a grand hunting-ground for botanists and entomologists. It is easy of access from their head-quarters, consequently we are not surprised to read in their recently published volume of "Transactions of Fifty Years," 1847 to 1896 inclusive, the accounts of numerous visits of exploration, and of fungus forays in the forest. This volume is a very valuable compendium of the natural history of their county, rendered infinitely more useful by the completeness of its index, which may be called a model index, by reference to which the habitat of rare plants, localities favoured by insects, occurrences of fossils, and anything pertaining to local natural history or of local historical interest can be readily ascertained. At 3 p.m. the town of Bewdley was reached, and luncheon was prepared in the large room of the George Hotel. After lunch a paper giving the results of examination of the colouration of *Helix (Tachea) memoralis* was read by Mr. A. E. Boycott. The Rev. Richard Evans, of Eyton Hall, was elected a member of the club. Dr. Crespi was chosen delegate to the annual fungus foray of the British Mycological Society, to be held in Sherwood Forest in September. Amongst other business, the President reminded the members that Part ii. of the Archæological Survey of Herefordshire was published, also that a magnificent immature female white-tailed eagle (*Haliaeetus albicilla*) which had been hovering over the Shobdon Hills last November, had been shot at Dinchope, near Craven Arms, Salop, on November 7th, and was now in the Museum. The measurement across wings was seven feet nine inches. Mr. G. W. Marshall (Saint Croix), of Sarnesfield, made the magnanimous offer of editing the parish registers of any one parish of the city which the Vicar or Rector may desire to publish. At the present time there is only one parish register in the county published, namely, that of Upton Bishop, by the late Rev. Dr. F. Havergal. Some members visited a splendid collection of shells, birds, horns and antlers, skins of animals, cast-off skins of rattlesnake, and specimens of handiwork of natives from Madagascar and South Africa. Others visited Ribbesford Church, and some found time to cross the River Severn and inspect the large caves or hermitage in the Bunter Sandstone cliffs at Blackstone, which are described in the "Transactions of the Worcestershire Field Club," page 383, in Mr. Noake's paper on "Cells and Hermitages in Worcestershire."

NORTH LONDON NATURAL HISTORY SOCIETY.—Thursday, July 1st, 1897. Mr. C. Nicholson, F.E.S., President, in the chair. Exhibits: Mr. Battley, living specimen of *Apamea ophiogramma*, bred the same evening. Mr. Simes, a specimen of the leaf butter bee (*Megachile centuncularis*), taken that evening in a garden at Clapton, where it affects rose and sycamore. Mr. L. J. Tremayne, examples of the Amphidasidae, plants from the New Forest at Whitsuntide, living larvae of *Panolis piniperda* from Oxshott, and pupae of *Thecla quevens* from larvae taken in the New Forest at Whitsuntide,—one of the imagines had just emerged. Mr. C. Nicholson, larvae of *Euchloe cardamines*, *Iodis lactearia*, *Boarmia consortaria* (and female parent), also two *Ocneria dispar*, one being a wild French one and the other one descended from several genera

of parents bred in England; the latter was quite ordinary in colouration, but the former was almost entirely black along the back, the usual tubercles being very dark; also pupae of *Ephyra penularia*. Messrs. Prout and Bacot also exhibited. Mr. Battley recorded a specimen of *Spilodes verticalis (cinctalis)* at light at Stamford Hill. He also found a number of clover-leaves with four leaflets and one with five, and remarked that the so-called "four-leaved shamrock" did not appear to be so rare as generally supposed. Mr. L. J. Tremayne recorded *Tanagra atrata* from Brondesbury Station, and said that a fine fresh specimen of *Phorodesma pustulata* flew into light at his bedroom window on Wednesday night, June 30th, at 51, Buckley Road, Brondesbury. He also enquired whether the larva of *Panolis piniperda* was a known cannibal, as he believed the large larva of that species, which he exhibited, had recently attempted to devour a couple of his smaller brethren when rather short of food. Mr. Prout said that all the members of the genus *Taeniocanipa* were cannibals, and it must be remembered that Dr. Chapman declared *piniperda* to be not even generically distinct from them. Mr. Prout opened a discussion on the Amphidasidae which he described as a small and tolerably compact group, generally placed, and no doubt rightly, somewhere near the Boarmiidae. Guenée had them after Ennomidae (last British species, *Himera pennaria*) and Hemerophila (first British species, *Hemerophila abruptaria*). Standing had them before *Anisopteryx* (which followed the genus *Hybernia*) and *Hemerophila*. They were perhaps next to *Anisopteryx* and *Hybernia* on account of their frequent winter appearance and wingless females, but there was nothing scientific in that, and Mr. Prout did not see the slightest relationship here. Packard, however, said the venation of *Hybernia* agreed with *Biston* and *Amphidasys*. The earlier stages of *Himera pennaria* were unknown to Mr. Prout, but the Amphidasidae seemed to have some connection with *Selenia*, and the young larvae were something like *Tephrosia*, etc. The British genera comprised *Phigalia*, *Biston*, *Nyssia*, and *Amphidasys*. The Museum collection showed very few, if any, links with the Boarmids; hence the group would appear tolerably specialized. They there formed part of the great sub-family Boarminae, which included Ennomidae, Fidoniidae, etc., of Guenée, following some "thorn" genera, and preceding *Hybernia*. Meyrick also had these united in one family—his Selidosimidae. Packard kept Ennominae and Fidoniinae away from Boarminae, but included the winter groups Hyberniidae and Amphidasidae of Guenée with the Boarminae. Mr. Tutt also led on from Hyberniidae to Boarmidae, and thence to Amphidasidae, though giving each family rank. He also incidentally suggested that the Fidoniidae may have strong affinities with certain of the Boarmids. The British Museum collection contained nearly thirty species of Amphidasids, several being Asiatic and North American. The Americans had two or three representative species or local forms: thus *cognataria*, Gn., for our *betularia*; *ursaria*, Walker, for our *hirtaria*; and *strigataria* for our *pedaria*. Mr. Prout also noticed a few typical Amphidasids partaking of some features of both our British species, *strataria* and *betularia*. He suggested that these two were very closely allied, and that Standing was wrong in removing *strataria* into genus *Biston*. Experiments had shown that the two could easily be hybridized, if

only one could get them out at the same time. On the other hand, it was just possible *Nyssia* had some right to be included with *Biston*. *Hirtaria* and *hispidaria* seemed pretty close in some ways, but perhaps our British system of genera was the best. *Pingalia*, with one species, was fairly distinct, yet the larvae, and to some slight extent the female imago, brought it rather close to *hispidaria*. *Nyssia* was an interesting genus of rather small moths, stoutly built, with very hairy and apterous females, containing Alpine, boreal, and other local species. *Biston* was restricted, since it contained apparently *hirtaria* only and its American representative, *arsaria*. Mr. Prout referred to its geographical range. It was evidently local, both on the continent of Europe and in Britain. Why should it be so attached to London? The female was winged, but hardly seemed to fly much. Mr. Prout gave an instance of its being supposed to assemble to the males, the latter being pinned on to a tree, and a female being found in *Populus* with it in the morning. Mr. Dadd said that *hirtaria* was inclined to have the wings very rudimentary. He had frequently found both males and females paired on the same tree-trunk, on which they seemed to have emerged. Mr. Bacot said: The newly-hatched larvae of Ennomidae, Amphidasidae, and Boarmidae fell into two distinct groups. In the first, the freshly emerged larvae were dark coloured, spotted with white, the spots having a tendency to form into rings or bands at or near the juncture of the segments. In the second group the larvae were of some shade of green or brownish-green, with light lateral or spiracular bands, and possibly with pale longitudinal lines or bands on the dorsal and sub-dorsal areas. He imagined that the characters of newly-emerged larvae were of equal value for purposes of classification with the characters of either oval or imaginal stages. Hence such widely different characters in the newly-hatched larvae pointed to the possibility of there being two distinct groups of Geometrid moths included in the before-mentioned families, any one of which families contained larvae of both forms. Unfortunately, he was not acquainted with the larvae of all the moths comprised in these three families. With regard to the species he had knowledge of, they could be placed in the two groups as follows: Group 1—*Actinoma frumaria*, *Eumyza loboraria*, *Eugenia linaria* and *E. quercinaria*, *Amphidasys strataria* and *A. setularia*, *Hemerophila abnuptaria*, *Boarmia citharata*, and probably *B. consortaria*. Group 2—*Selenia autumnaria*, *S. linaria* and *S. tetralonaria*, *Pingalia gelata*, *Nyssia zonaria* and *N. hispidaria*, *Tephania bistriata* and *T. crepuscularia*. Mr. L. J. Tremayne enquired whether the Amphidasidae ever came to sugar, like their allies, the Boarmidae. Mr. Battley thought we had a very curious example in *Amphidasys betulina* var. *doubletaria*. This insect had gone black in the Midlands of England within the last forty or fifty years, and was clearly going black in London. It should form a good subject for experiment. Certainly all the Amphidasidae were remarkably easy to assemble. Mr. C. Nicholson said that this group could not come to sugar, as they had practically no proboscis. Mr. Prout, in the course of his reply, said that from the discussion it seemed that some redistribution of this group might probably become necessary. There were no doubt close affinities with *Selenia*. It was curious that the continental *hirtaria* were totally different from ours. Zeller's collection had no dark forms, except one from London.—On August 2nd, 1897, the society's

excursion took place to Shere, Surrey. The party left London about eleven, but did not arrive at their destination at Gomshall Station until the early afternoon, whence they walked over to Shere. After inspecting the Church, admiring its Norman doorway, and ascending the belfry, the members passed through the village and to the northwards towards the chalk downs. The best insects taken included several *Hesperia comma* and *Thecla is-aëdon*. A few local plants were also noted.—Lawrence J. Tremayne, Hon. Secretary.

GREENOCK NATURAL HISTORY SOCIETY.—Excursion to Millport on August 21st. Landing at Keppel Pier from an early steamer, the party, which included a contingent from Rothessay, first visited the Marine Biological Station. There the members found many things to interest them. There is the collection of fossil and contemporaneous shells formed by the late Dr. Robertson, with his seaweeds, beautifully mounted by Mrs. Robertson. Dr. John Murray, of the "Challenger," also contributes many interesting exhibits. The beautiful specimens sent by Dr. Anton Dohrn, of Naples, were much admired. This distinguished naturalist, by some special method, contrives to prepare his specimens so that when placed in spirits of wine they retain the exact appearance and positions occupied by the organisms at a given moment while in life. The local objects preserved also created considerable interest. The visitors also inspected the laboratories, etc., under the courteous guidance of the curator. Captain Alexander Turbyne, for some years assistant to Dr. Murray, is in charge of the station, and appears to take much interest in the work of investigation. The members afterwards proceeded along the southern shores of the island on a botanical survey. No plants of particular importance were met with, and the party returned in the early part of the evening.—G. W. Niven, Hon. Secretary.

## NOTICES OF SOCIETIES.

THE SOUTH LONDON ENTOMOLOGICAL AND NATURAL HISTORY SOCIETY.

- Oct. 23.—"Recent examples of the effect on Lepidoptera of extreme temperatures applied in the pupal stage." Mr. Merfield, F.E.S.  
 Nov. 11.—"The drinking habits of butterflies and moths." Mr. Tutt, F.E.S.  
 " 25.—"Lantern pictures of birds and their nests." Mr. Harrison, F.C.S.

NORTH LONDON NATURAL HISTORY SOCIETY.

- Oct. 7.—Pocket Box Exhibition and Microscopical Evening.  
 " 21.—Special Meeting to consider the New Rules.  
 " 30.—Visit to the Natural History Museum, South Kensington. Leader, S. Austin.  
 Nov. 4.—"Through Cornwall and Devon." J. A. Simes.  
 " 18.—Debate: "Does scientific study destroy or militate against the æsthetic tastes or sense?" Opened in the affirmative by F. W. Frost; opened in the negative by A. Bacot.  
 Dec. 2.—"Insectivorous Plants." R. W. Robbins.  
 16.—General Business Meeting—Election of Officers for 1898.

LANTERN FIELD CLUB AND SCIENTIFIC SOCIETY.

- Nov. 1.—"Prehistoric Man." G. F. Lawrence.  
 " 15.—"Photomicrographs of Insect Anatomy," with lantern illustrations. F. Clark.  
 " 20.—"Visit to British Museum, Prehistoric Section.  
 Dec. 6.—"Fossils, and the ways in which they are found preserved." Dr. H. F. Parsons.  
 " 11.—"Visit to Natural History Museum, Shell Gallery.  
 " 13.—"Photographic Demonstration." C. J. Stokes.

1898.—NOTICES OF SOCIETIES.  
 Oct. 16.—Annual Meeting, Rambling Club, Natural Science Laboratory, University College, Nottingham, 4 p.m. Tea, notice and exhibition of collections made during season. W. Incheron, Hon. Sec., 17, Noel Street, Nottingham.

## NOTICES TO CORRESPONDENTS.

TO CORRESPONDENTS AND EXCHANGERS.—SCIENCE-GOSSIP is published on the 25th of each month. All notes or other communications should reach us not later than the 18th of the month for insertion in the following number. No communications can be inserted or noticed without full name and address of writer. Notices of changes of address admitted free.

NOTICE.—Contributors are requested to strictly observe the following rules. All contributions must be *clearly* written on one side of the paper only. Words intended to be printed in *italics* should be marked under with a single line. Generic names must be given in full, excepting where used immediately before. Capitals may only be used for generic, and not specific names. Scientific names and names of places to be written in round hand.

THE Editor is not responsible for unused MSS., neither can he undertake to return them, unless accompanied with stamps for return postage.

SUBSCRIPTIONS.—Subscriptions to SCIENCE-GOSSIP, at the rate of 6s. 6d. for twelve months (including postage), should be remitted to the Proprietors, 86, St. Martin's Lane, London, W.C.

THE Editor will be pleased to answer questions and name specimens through the Correspondence column of the magazine. Specimens, in good condition, of not more than three species to be sent at one time, *carriage paid*. Duplicates only to be sent, which will not be returned. The specimens must have identifying numbers attached, together with locality, date and particulars of capture.

ALL editorial communications, books or instruments for review, specimens for identification, etc., to be addressed to JOHN T. CARRINGTON, 1, Northumberland Avenue, London, W.C.

## CORRESPONDENCE.

F. McL. (Tal-y-Cafn).—No. 1 is a young fern too immature to identify; No. 2 is a sedge (*Juncus gerardi*, Lois); No. 3 is a grass (*Aira coespitosa*, L.).

J. C. ASTLEY.—No. 1, will answer later; No. 2 is a species of *Convallaria*, but cannot say which without flower; No. 3, *Ophiopogon taburan* var. *variegatus*.

L. K. (Worcester).—The 9th edition of the "London Catalogue of Plants" does not agree in nomenclature with any of the manuals of botany. We cannot say that one or other you mention is nearest the Catalogue in names. We have not heard of any new editions likely to be published of either British flora mentioned; not any are very recent.

## EXCHANGES.

NOTICE.—Exchanges extending to thirty words (including name and address) admitted free, but additional words must be prepaid at the rate of threepence for every seven words or less.

BRITISH land and freshwater shells offered in exchange for foreign (univalves).—G. T. Rope, Blaxhall, Wickham Market.

WANTED, offers for SCIENCE-GOSSIP from start (1865) to 1897, in good condition; 28 vols. in publisher's cover, remainder unbound.—G. P. Bonny, 30, Wellington Road, Stoke Newington, London, N.

WANTED, "Hull's British Coalfields," 4th edition; also Nicholson's "Manual of Palaeontology," latest edition; must be reasonable in price.—B. C. Constable, Heath Road, Stockport.

WANTED, foreign land and marine shells, crustaceans, echinoderms and sponges, wasp and hornet nests; also insect galls from trees.—H. Parriit, 8, Whitehall Park, N.

BIRDS' EGGS.—A few sets of genuine and authentic British-taken roseate terns' eggs, also herons', great plovers' and others, offered for other clutches.—E. G. Potter, 14, Bootham Crescent, York.

REV. J. W. HORSLEY, St. Peter's Rectory, Walworth, wants series of authentic varieties of *L. peregra*, for which he will give good exchange.

Will exchange Australian seaweed for foreign shells, also give 35 different Australian stamps for 45 fairly good foreign stamps.—J. P. Laker, c/o F. B. C., 78, Rundle Street, Adelaide, Australia.

FIFTY-ONE microscopical slides, with pine box, offered in exchange for clutches of birds' eggs; British and sea-birds' preferred.—E. Kitchen, 116, Eversleigh Road, Battersea, S.W.

OFFERED, Cox's "Handbook of Coleoptera," 2 vols., as new. Wanted, Newman's "Butterflies and Moths."—E. J. Denham, 31, Hugn Road, Small Heath, Birmingham.

STUDENT'S microscope, excellent condition, high and low power objectives, mahogany case; useful exchange entertained.—G., 186A, Edgware Road, W.

## METROPOLITAN SCIENTIFIC SOCIETIES.

The following is a list of societies in the London district devoted to natural science, with hours and places of meeting. They may be visited with introduction from a Fellow, Member, or Secretary. Will secretaries send additions or corrections.

ANTHROPOLOGICAL INSTITUTE OF GREAT BRITAIN, 3, Hanover Square. Second and fourth Tuesdays at 8.30 p.m., November to June.

CITY OF LONDON COLLEGE SCIENCE SOCIETY, White Street, Moorfields, E.C. Last Wednesday in each month, October to May, 7.30 p.m.

CITY OF LONDON ENTOMOLOGICAL AND NATURAL HISTORY SOCIETY, London Institution, Finsbury Circus. First and third Tuesdays, 7.30 p.m.

CROYDON MICROSCOPICAL AND NATURAL HISTORY CLUB, Public Hall. Third Tuesdays, October to May, 8 p.m.

DULWICH SCIENTIFIC AND LITERARY ASSOCIATION. Fortnightly meetings. (No information as to place and time.)

EALING NATURAL SCIENCE AND MICROSCOPICAL SOCIETY, Victoria Hall, Ealing. Second and last Saturdays, October to May.

ENTOMOLOGICAL SOCIETY, II, Chandos Street, Cavendish Square. First Wednesday, October to June (except January). Third Wednesday, January, February, March and November, 8 p.m.

GEOLOGISTS' ASSOCIATION, University College, Gower Street. First Friday, 8 p.m., November to July.

GEOLOGICAL SOCIETY OF LONDON, Burlington House, Piccadilly. Fortnightly, November to June.

LAMBETH FIELD CLUB AND SCIENTIFIC SOCIETY, St. Mary Newington Schools, Newington Butts, S.E. First Mondays all the year and third Mondays in winter, 8 p.m.

LINNEAN SOCIETY OF LONDON, Burlington House, Piccadilly. First and third Thursdays at 8 p.m., November to June.

LONDON AMATEUR SCIENTIFIC SOCIETY, Memorial Hall, Farringdon Street, E.C. Fourth Friday in each month, October to May, 7 p.m.

LUBBOCK FIELD CLUB. In connection with Working Men's College, Great Ormond Street, Bloomsbury, W.C. (No information.)

MALACOLOGICAL SOCIETY OF LONDON, meets in Linnean Society's Rooms, Burlington House. Second Friday each month, November to June, 8 p.m.

MINERALOGICAL SOCIETY. Meets in rooms of Geological Society, February 4th, April 14th, June 23rd, November 17th.

NONPAREIL ENTOMOLOGICAL AND NATURAL HISTORY SOCIETY, 99, Mansfield Street, Kingsland Road, N.E. First and third Thursdays, 8 p.m.

NORTH LONDON NATURAL HISTORY SOCIETY, North-East London Institution, Dalston Lane (Dalston Station). Second and fourth Thursdays, 7.45 p.m.

PHARMACEUTICAL SOCIETY OF GREAT BRITAIN, 17, Bloomsbury Square, W.C. Tuesday following first Wednesday of month, 8 p.m.

QUEKETT MICROSCOPICAL CLUB, 20, Hanover Square. First and third Fridays, 8 p.m.

ROYAL BOTANIC SOCIETY OF LONDON, Regent's Park. Second and fourth Saturdays at 3.45 p.m.

ROYAL HORTICULTURAL SOCIETY, 117, Victoria Street, S.W. Second and fourth Tuesdays, except December to February.

ROYAL METEOROLOGICAL SOCIETY, 22, Great George Street, Westminster. Third Wednesday, November to June, 8 p.m.

ROYAL MICROSCOPICAL SOCIETY, 20, Hanover Square. Third Wednesdays, October to June, 8 p.m.

SELBORNE SOCIETY, 20, Hanover Square. Does not hold winter meetings.

SIDCUP LITERARY AND SCIENTIFIC SOCIETY, Public Hall, Sidcup. First and Third Tuesdays, October to May.

SOUTH LONDON ENTOMOLOGICAL AND NATURAL HISTORY SOCIETY, Hibernia Chambers, London Bridge, S.E. Second and fourth Thursdays, 8 p.m.

SUTTON SCIENTIFIC AND LITERARY SOCIETY, Public Hall Chambers. Fortnightly. (No information of dates or time.)

WEST KENT NATURAL HISTORY, MICROSCOPICAL AND PHOTOGRAPHIC SOCIETY. Meets in School for Sons of Missionaries, Blackheath, third Wednesday, in December, fourth Wednesdays in October, November, January, February, March, April, May, 8 p.m.

WOOLWICH POLYTECHNIC NATURAL HISTORY SOCIETY, Polytechnic, William Street, Woolwich. 7.30 p.m., alternate Thursdays.

ZOOLOGICAL SOCIETY OF LONDON, 3, Hanover Square. First and third Tuesdays, 8 p.m., November to August.

THE KENT COAL-FIELDS.

BY EDWARD A. MARTIN, F.G.S.

IN this and the following number of SCIENCE-GOSSIP will be found an important series of diagrams, illustrating in detail the whole of the strata which have been passed through in the making of the now famous boring for coal at the foot of Shakespeare Cliff, Dover. This is, I believe, the first time that the details here given have been allowed such wide circulation, and acknowledgments are due to Francis Brady, Esq., M.I.C.E., for permission to reproduce the diagrams which, on a larger scale, he has published as engineer

bottomed), at a depth of 931 feet. Another boring was made at St. Margaret's Bay, starting this time at sea-level. Here the bottom of the Chalk was reached at 548 feet, the boring leaving off in the Gault.

The now famous boring, at the bottom of which coal has been reached, is situated on the Great Fall at the foot of Shakespeare Cliff, to the west of Shakespeare Tunnel. Being close to the outcrop of the impermeable Grey Chalk, it is peculiarly favourable, from an engineer's point of view, for pit-sinking.

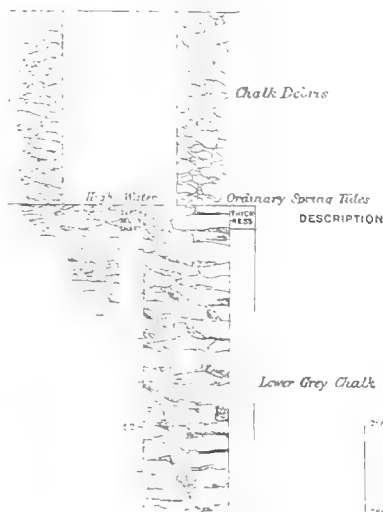

SECTION OF BORING FOR DOVER COLLIERY.



to the Channel Tunnel Company.

It will be unnecessary to do more than remind readers that the occurrence of an ancient underground surface bearing detached coal-basins was predicted by Godwin-Austen and Prestwich. The latter reported very fully on the subject in his communication to the Royal Commission on Coal, the results of whose investigations were published in 1871. He thought that the coal area might extend for 150 miles, with a breadth of two to eight miles.

Previous borings have been made at Dover. That at the convict prison started from a height of 280 feet above sea-level, reaching the base of the Chalk at 675 feet. Passing through the Gault (143 feet) and Lower Greensand (31 feet), the boring finished off at the Wealden Beds (82 feet, not

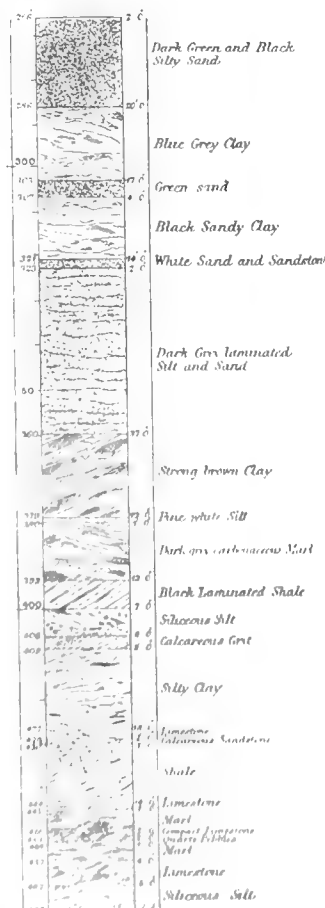

The spot is almost within sight of Calais, where the Coal Measures have been found at a depth of 1,104 feet. The discovery of coal at Dover is the first of a series of coal-fields which, looking into the future, we may live to see stretching right away from Bristol, in the direction of a line connecting that coal-field with the Pas de Calais. Borings near the River Thames, in reaching strata older than the Carboniferous, have disposed of the possibility of Coal Measures being found actually beneath London. But geologists agree that the disappearance of Wealden Beds between the North Downs and such places as Richmond, Tottenham Court Road, Streat-ham, Crossness, and Chatham, where borings have been made, points to their having been deposited against an axial east and west ridge, which may contain the coal-basins for which we are in search, and that, therefore, the range of the Downs offers the greatest possibility of success. Prestwich thought they should be looked for on a line passing from Radstock, in Somerset, thence through the Vale of Pewsey, and thus along the North Downs to Folkestone. The ancient land-surface rises so rapidly beneath London as to reach a depth of but 795 feet from the surface at Ware, in Herts, at which the Silurians were touched.

Before the Dover boring was commenced, a shaft was sunk to sea-level, *i.e.* 44 feet deep. It must, therefore, be understood that in referring here to depths of various strata, 44 feet must be added to the measurements given in the sections quoted in this article, unless stated otherwise.

From the diagram it will be seen that the Grey Chalk extended to a depth of 91 feet, after which followed a thickness of 39 feet of Chalk Marl and 8 feet of Chloritic Marl, this representing the so-called Upper Greensand. The Gault was of great thickness, reaching no less than 121 feet. Next followed the Neocomian, or Lower Greensand. According to Professor Boyd-Dawkins, 660 feet of Jurassic strata were then bored through, Portland Beds, Kimmeridge Clay, Corallian Series, Oxford Clay, Kelloway Rock, and Bath, or Lower, Oolite, all being represented. According to Messrs. Brady, Simpson and Griffiths, the thicknesses were as follows:

Grey Chalk and Chalk Marl	..	174	feet
Chloritic Marl	.. ..	8	„
Gault	.. ..	121	„
Lower Greensand, Wealden and Hastings Beds	.. ..	241	„
Upper, Middle and Lower Oolites, and Lias	.. ..	613	„
To Coal Measures	..	1,157	feet

The Coal Measures were at length struck at 1,113 feet from the bottom of the shaft, whilst

from 24 feet further down came reports of 2½ feet of good house coal, containing, however, a thin sandstone parting. The strata then gave continued evidence of their origin, the sandstones being streaked here and there with coal, with, now and then, valuable seams of the same material. Omitting those of less than one-foot in thickness, ten seams were encountered, yielding altogether 21 feet 11 inches of coal.

In the valuable and concise paper read before the North of England Institute of Mining and Mechanical Engineers, by Messrs. F. Brady, M.I.C.E., G. P. Simpson, F.R.G.S., and Nath. R. Griffiths, an analysis of coal from the lower seams in the Dover boring, gave the following result:

Carbon	.. ..	83.8
Hydrogen	.. ..	4.65
Nitrogen	.. ..	.97
Oxygen	.. ..	3.23

Owing to the high percentage of volatile matters, Mr. Watteyne rejects the idea that the Dover coals belong to the base of the formation, in spite of some correspondence in structure between some of the sandstones in the boring, and those of the lowest regions of the Coal Measures in Belgium.

The great four-foot seam of good bituminous coal was discovered at a depth of 2,177½ feet from the top of the bore-hole, or 2,221½ feet from the surface.

The important question remaining is to ascertain whether by a continuation of the boring there is the possibility of further coal seams being reached. The fact of the seams being horizontal shows that here, at any rate, if this be one of the detached coal-basins, we are in the centre of such basin, but this horizontality throws little light on the thickness of the measures. The boring was continued 105 feet below the four-foot seam, a total of 1,173 feet of Coal Measures being bored through. This is more than one-half of the whole depth of the boring, but from a mere stratigraphical point of view it does not follow that there is no further great thickness below. In South Wales we have no less than 11,000 feet of coal-bearing strata, so that there is no great impossibility of finding a still greater thickness below.

It is fairly possible to judge, however, as to the position which these Coal Measures bear stratigraphically, from the fossils which have been brought up by the boring-tool. The best specimens of organic life were submitted to M. R. Zeiller, of the School of Mines, Paris, for identification. Vegetable remains from three levels were examined with the following results.

From a depth of 1,894 feet from the surface the following ferns were found: *Odontopteris* (? *Mariopteris sphenopteroides*, Lesq.), *Neuropteris scheuzeri*,



*N. rarinervis*, *N. tenuifolia*, *Lepidodendron aculeatum*, *Cordaicarpus*.

From 1,900 feet were identified: *Neuropteris scheuzeri*, *N. rarinervis*, *N. tenuifolia*, *Cyclopteris* (a fragment), *Calamophyllites goepperti* (Ettingsh.), *Lepidostrobus variabilis*, *Cordaicarpus*.

From 2,038 feet came: *Stigmaria ficoides*, *Lepidodendron lycopodoides*, *Neuropteris scheuzeri*.<sup>(1)</sup>

M. Zeiller reports decisively on *Neuropteris rarinervis* and *N. scheuzeri*, as having only been observed, either in America or in Europe, towards the top of the Middle Coal Measures, or at the extreme base of the Upper. In the Radstock and Faringdon Beds, in Somersetshire, these two fossils are common. M. Zeiller concludes that from the position of the beds traversed, they rightly belong to the Middle Coal Measures.

In the Natural History Museum are some specimens from the Dover boring, two being of the genus *Neuropteris*, and one fairly agreeing with *N. scheuzeri*. These came from depths of 1,262 feet and 2,038 feet from the surface. They are, however, but fragmentary, good and perfect specimens being rare in a narrow core. The same fossil, it is as well to bear in mind, was brought from a depth of 1,174 feet from the surface at Burford, in Oxfordshire.

There are also in the Museum four cores from Dover. One is from 1,262 feet from the surface, composed of grey sandstone and grit, and streaked with coal, the streaks being inclined at a slight angle. The seams of coal are, however, completely horizontal. A core of true coal is exhibited from 2,039 feet, and another with coal and grey grit intermingled, from 2,088 feet. There is also a core of grey sandstone grit from 2,234 feet, which is below the four-foot coal-seam (2,221½ feet).

A peculiarity of the Kent coal-field will probably lie in its great length as compared with its width. It is the most westerly of that series of coal-fields which, starting from Westphalia, proceeds by way of Ruhr, Aix-la-Chapelle, Liège, Hainault and Valenciennes. These Belgian coalfields extend west and east for over two hundred miles, whilst their width never exceeds eight miles.

Even if the Coal Measures and Devonians pass in a north-westerly direction beneath London towards Burford or the Midlands—the Carboniferous and older rocks occurring in detached basin-shaped areas with denuded outcrops, we know, at least, that between Ware (Herts) and Streatham, there are no Coal Measures. But the probabilities are that at least one line of detached coal-basins occurs by way of Ashford, Tonbridge and Reigate, to the Bristol coal-field, and that this rising ridge of Palaeozoic rocks was that against which the Wealden estuarine deposits came to be cut off and confined to within narrow limits, no intermediate

Oolites being found, be it remembered, at Crossness, Meux's, Turnford, or Ware, and the Wealden not reaching so far north as Chatham, Crossness, or Richmond. Prestwich states that it is on the north flanks of the older rocks of the Ardennes range of hills that the coal-fields of Belgium lie. The long and narrow south of England coal-fields, which in the future will be opened up, will lie south of the rise of the Palaeozoic rocks before referred to, and north of a prolongation of the line of disturbance which Prestwich noticed in the Ardennes, and a continuation of which he announced as being exhibited in the Mendips.

The discovery, made as far west as Richmond, in Surrey, of fragments of anthracite intermingled with pebbles of Coal Measure sandstone, in the junction-beds both above and below the Bath Oolites, gave unmistakable evidence of an exposed Carboniferous surface in Mesozoic times, at a spot where coal-measure sandstone was intersected by a seam of anthracitic coal. Professor Hull concludes that, from the brittle nature of such coal, these fragments must have been derived from no very distant surface. The gap in the downs in the neighbourhood of Dorking is about fifteen miles due south of the Richmond boring. It is on our line of conjectural coal-basins, and great changes may in the future wait upon even that fair district.

It would probably be unwise to attempt to obtain coal as far north as Streatham, since there, at a depth of 1,120 feet, beds of probable Devonian age were reached in which were found what appeared to be fish remains. If the Coal Measures lie, as is anticipated, in narrow basins, the fact that Carboniferous Beds were not met with at Streatham confines the westerly extension of the Dover beds to within a comparatively narrow area. Nor would it be wise to anticipate that the coal basins extend as far south as Battle, near Hastings, since here, although a depth of 1,905 feet was pierced, no Palaeozoic Beds were reached, the Wealden Beds attaining a very great thickness. Beyond London, certainly beyond Ware, there may be another trough of these old rocks in which relics of the Carboniferous surface is still in existence. There must be a trough of some sort, in order to account for the distance northwards to which the rise of the Coal Measures is deferred. Between Streatham and Ware, that is, beneath London, there is but the faintest possibility of coal at any time being found.

It is no new thing that coal should be worked beneath the Chalk. It is of constant occurrence in the Pas de Calais, although it was only as recently as 1864 that these measures came to be worked. Now, so important has this coalfield come to be regarded, that more than a third of the coal raised in the whole of France comes from that area.

<sup>(1)</sup> "Compte Rendus des Académie des Sciences" (Paris 1890).



## COLORATION AND VARIATION OF BRITISH EXTRA-MARINE MOLLUSCA.

BY ARTHUR E. BOYCOTT.

THE problems of variation have of late years been a subject of study with an ever-increasing body of naturalists. People who are not professional investigators of science have begun to recognize that the be-all and end-all of their work is not merely to collect "all the British species" of a certain group. Nor yet is it to discuss, with much vehemence, the question of specific *versus* varietal rank, or whether a special butterfly has really been caught in Kent.

The bitterness of the arguments is often quite disproportionate to the importance of the points at issue. At the same time it is a cause of infinite congratulation that we see less and less of this kind of thing in the literature of British land and freshwater mollusca. The number of species is so small that even the "mere collector"—I speak in no disparaging sense—is compelled to turn his attention to the varieties which are so well marked and numerous. William Bateson, in his book, "Materials for the Study of Variation," says: "Many of the problems of variation are pre-eminently suited for investigation by simple means. If we are to get further with these problems, it will be, I take it, chiefly by study of the common forms of life. Anyone can take part in this class of work, though few do." The whole question rests fundamentally on a very extensive collaborative and systematised collection of facts, often minute, many of them matters of simple observation, requiring no special training or qualities beyond those which every naturalist must possess—eyes, fingers and common sense. One of the most important details in the work is, what is done should be accurate. To know that a certain locality produces *Pupa secale*, for example, of a larger and stouter build than some other spot, is interesting, but now more or less useless, unless we know how big the specimens are from each place (1). This entails measuring the shells if it be a question of variation in size, which is, it must be confessed, very tedious and laborious work, especially if there is practically little or no variation to be found in a long series. Work done in this way admits of general tabulation. The most important part of the work is that many observers should do it simultaneously and on one general plan, so that all the results may from time to time be collected and collectively examined. The present sketch is not meant by any means to be a complete account of the subject, the fringe of which

has only just been touched; but its object will have been amply fulfilled if more conchologists can be persuaded by these notes to forsake the paths of species-hunting, and turn their attention to the more general biological problems. The variations found in British terrestrial and freshwater mollusca are really extremely large. We have only to turn to the pages of J. W. Taylor's (2) recent book to find examples: e.g., *Cryptomphalus aspersus* may vary in weight from 0.259 to more than 6.48 grammes, and *Anodonta cygnea* from a normal of 21 grammes to as much as 159 grammes. This large variation renders the group particularly adapted for study, especially when we take into account the fact that they show an unusual plasticity in form, etc., according to differences in habitat and other "attendant circumstances."

First, then, to consider the practical methods of studying variation in size. Here, naturally, the most important instrument is one by which we can accurately ascertain the size of our shells (2). The rough method of direct application of a rule to the shell is altogether too crude, except for large *Anodonta* and such shells. The method of callipers is much better, but in many cases is not susceptible of sufficiently fine work. It is always difficult to manipulate it with any certainty and rapidity. The best instruments for the purpose are no doubt the micrometer screw gauges made by the various physical instrument makers, though too often at somewhat exorbitant prices. These measure to 0.01 mm. as a rule, which is an accuracy rather beyond what is generally required (3). On the other hand, the direct scale can really only measure to whole millimetres, and that inaccurately, which is going too far to the less preferable extreme. Accurate measurement in whole millimetres is not fine enough for many of the smaller English species. An instrument which I have used with all success, and which has given

(1) Monograph of Br. L. F. W. Moll, i. (part ii.), pp. 77-79 (1895). I have given rather full references throughout, in many cases perhaps unnecessarily; but I trust they will be of some use, both as authorities for my facts, and as indicating where a fuller treatment of the various points may be found.

(2) The variation in the shell is mainly considered as a convenient part to study. In many ways it is also an index to the mode of life of its inhabitant. The old method, which gave all importance to the shell, equally with the new, which disregards this important and prominent organ, are erroneous, from a biological and systematic point of view.

(3) It would have seemed hardly necessary in 1897 to urge the adoption of millimetres and grammes in all such measurements, had not two recent authoritative works on the subject given us a mixture of inches and grammes, grains and millimetres, with the extraordinary statement that millimetres for bivalves "would have been absurd."

(4) And measurements sometimes very much upset preconceived notions as to relative size.

me every satisfaction, is a small clockmaker's gauge (measuring up to 10 cm.) made by Boley, of Esslingen (1). It is a slide-gauge, and reads with a vernier to 0.1 mm., which is sufficiently accurate for ordinary purposes. It is always well to err on the side of excessive minuteness, as anyone who has tried extensively knows that the personal equation and the equation of the moment may mean a more or less a considerable percentage variation in the results on the same shell measured by different persons or at different times. A gauge such as this, as ordinarily used, may probably be regarded as accurate to 0.2 mm.

Quite small species, such as *Vertigo*, *Carychium*, should perhaps be measured to 0.01 mm. It is practically impossible to do this with a sliding instrument, indeed it is dangerous with any sort of gauge in which the shell must be held fast between two hard points. The simplest way seems to be to measure them under the microscope with a power of 50 diameters or less. The practical difficulties of successfully applying the slide-gauge to such shells as *Vitrea*, *Balia*, etc., are also not inconsiderable. It is easier to measure these on a microscope with a travelling stage fitted with scales and verniers. It need hardly be mentioned that a qualification which any practical measurer for these purposes must possess, is ease and rapidity of working. Life is much too short to make two or three measurements and a weighing on many thousand specimens up to 0.01 mm. and 0.0001 grammes, at least this is so to ordinary mortals.

The question next arises, in what direction exactly the measurements are to be made. Most books simply say: altitude, so many millimetres, or lines, etc., diameter, so much; unless they assure us that the species is about as big as a hazel-nut, or some other object of unvarying and immutable magnitude. Is the altitude measured parallel with the axis (columella) of the shell? Is it the extreme length from the apex to the most produced part of the mouth, or from the apex to the umbilicus, along the axis? Is the diameter taken parallel with the slant of the whorls, or at right angles to the altitude?

C. A. Westerlund (2) distinguishes two measurements of height (altitudo, e.g., in "*Helix*," *Hyalinia*), or length (longitudo, e.g., in *Buliminus*, *Clausilia*): (1) altitudo major, from the apex to the lowest part of the mouth: he appears to say that this distance is measured parallel with the axis; (2) altitudo minor, from the apex to the middle point of the underside of the shell, i.e. the umbilicus.

(1) It may be procured from Messrs. Grimshaw and Baxter, 33 and 35, Goswell Road, Clerkenwell, London, E.C., price 5s. It has the disadvantage of not being long enough for large bivalves, nor hardly broad enough for such species as *H. pomatia*; it takes *Cryptomphalus* easily enough.

(2) *Fundamenta Malacologica* (1892), p. 71.

The plan which I have provisionally adopted is as follows.

All helicoid shells have their altitude measured parallel with the columella, or assumed columella, and from the apex to the extreme point of the mouth or point on the last whorl which is most distant from the apex (1). That is to say, the altitude lies along a line drawn from this point parallel with the axis to a point where it meets a line drawn laterally from the apex at right angles to the axis. The diameter is the greatest distance from the peristome to the exposed part of the last whorl. It is not perpendicular to the altitude line, nor parallel with the slant of the whorls, but is intermediate in position in *Cryptomphalus* or *Tachea*. In the flatter snails it is almost or quite perpendicular to the altitude line. The chief point to be careful about in measuring such shells as *Tachea* and the other *Helix* genera, is to have the columella parallel with the long limb of the gauge. It is of necessity a point in which one cannot altogether exclude variation dependent on the time or individual.

In passing, I may mention that there is another method of measuring *C. aspersus*, which gives rather interesting results. The altitude is measured diagonally from the apex to the furthest point on the peristome, and the diameter is the distance from the peristome to the exposed part of the last whorl, when the shell is resting naturally with its aperture downwards. The measurements are more adapted for use with callipers (altitude), and direct reference to the scale (diameter). If now the fraction  $\frac{\text{diameter}}{\text{altitude}}$  is taken, those shells in which it is less than one may be called conoid, those in which it is more than one, globose.

In shells like *Paludina*, *Cyclostoma*, *Buliminus*, *Clausilia*, etc., the altitude is again parallel with, and almost along, the columella; and the diameter is the greatest width perpendicular to this. All other univalve British forms fall naturally under one of these two heads. It is important to remember that the "real" altitude of *Planorbis* must be measured in the centre along the columella: this is done with the curved limbs of the Boley gauge.

These two methods of diameter measurement are not, I think, particularly disadvantageous, as the object is not so much to make comparisons between the sizes of different species as between individuals of the same species, and to have a method which gives accurate and regular results, while it is easy and rapid of execution.

Westerlund distinguishes *latitudo major*, which is the whole breadth of the shell measured to the outer edge of the peristome, from *latitudo minor*, which is measured at right angles to this. Both

(1) In *Tachea* it is sometimes a point on the peristome, sometimes on the last whorl.

seem to be taken parallel with the suture. The divergence between the results obtained by the two methods of measurement of diameter may be illustrated by the following example. A series of eighteen specimens of *Paludina vivipara* from the Hereford and Gloucester Canal, near Hereford, gave alt. (measured parallel with axis), max. 39.8 mm., min. 33.0, mean 34.9; diam. (perpendicular to axis), max. 27.8, min. 22.7, mean 24.4; and diam. (parallel with suture), max. 29.1, min. 25.8, mean 27.3. It is further to be noticed that the two methods of measurement do not agree with each other as to individual specimens. Thus, if we arrange the series above in the order of descending magnitude of diameters perpendicular to axis, and represent the specimens by the numbers 1 to 18, the corresponding numbers of the series similarly arranged according to the other diameter are: 1, 2, 8, 4, 4, 2, 8, 6, 13, 10, 11, 16, 15, 11, 14, 16, 18, 17. Part of this is no doubt due to errors in measuring, but part also to a further variation in the shape of the shell, which I hope to deal with later in this paper.

In measuring bivalves there is: (1) the length, measured from the extreme anterior to the extreme posterior points; the results are often slightly inaccurate owing to the presence, absence, or varying flexibility of the fringe. (2) The breadth; the position of this line is rather difficult to define, but not hard to determine in practice. It may, perhaps, best be said to be the greatest distance perpendicular to the lowest part of the lines of growth (*i.e.* the part furthest from the umbones); it may be, but not necessarily, perpendicular to the length of line, and one end may or may not coincide with the umbones, more often, perhaps, meeting the ligament at the hinge. (3) The thickness is measured with the valves closed tightly together.

Westerlund (!) gives very elaborate instructions (after R. J. Bourguignat) relative to the measurements of bivalves. The process is, however, needlessly complicated, entailing eleven separate measurements. It is only useful as a very imperfect substitute for figures, which are really almost more necessary in *Anodonta*, *Unio*, etc., than anywhere else, where the concavity of the lower margin, and especially the form of the posterior end of the shell two striking and important characteristics cannot unfortunately be satisfactorily exhibited in measurements.

Besides knowing the absolute length and breadth of a shell, which indicates the size, it is also useful to know the relation of the two measurements to one another, which partly indicates the shape. This is effected by calculating the fractions  $\frac{\text{diameter}}{\text{altitude}}$  or  $\frac{\text{altitude}}{\text{diameter}}$ , the former being perhaps the more convenient for the flatter, the latter for the

more produced species. By this means it is possible to express the two great deviations of shape in Gastropoda, conoidity and globosity, in terms of numerals. Further, the varieties *conoides*, *globosa*, etc., may be thus more closely defined, if it is deemed more convenient to call them by names than by numbers. In the case of a shell such as *Tachea nemoralis*, for example, it is found that in a series of such fractions, worked out from measurements of altitude and diameter, there are a good many near one another. This is the normal degree of globosity or conoidity for the particular series. In others the fraction  $\frac{\text{diameter}}{\text{altitude}}$  gradually rises to a maximum; these are the globose ones; while at the other end there is a corresponding fall which represents the conoid specimens. I hope later to discuss this point more fully, but at present I will only give the following examples:

	DIAM.	ALT.	$\frac{\text{DIAM.}}{\text{ALT.}}$
<i>Patula rotundata</i> , Herefordshire, Silurian..	6.0 mm.	2.5 mm.	2.40
(Above z = flattish.)	6.3	2.8	2.25
	5.5	2.8	1.96
	6.2	3.2	1.94
	5.7	3.0	1.90
	ALT.	DIAM.	
<i>C. aspersus</i> , Hereford	32.6	36.8	1.129
(Anything less than 1 is quite conoid.)	28.4	31.8	1.120
	31.1	33.9	1.090
	31.1	30.5	0.981
<i>Ch. lapicida</i> , Herefordshire .. ..	9.0	16.7	1.86
(Less than z = high-spired.)	9.2	17.4	1.89
	8.4	16.8	2.00
	7.9	17.6	2.23
	6.9	16.0	2.32
			$\frac{\text{ALT.}}{\text{DIAM.}}$
<i>Bul. obscurus</i> , Herefordshire .. ..	8.4	3.5	2.40
	8.5	3.6	2.36
	8.2	3.5	2.34
	7.7	3.3	2.33
	8.3	3.6	2.305
	7.8	3.4	2.29
	LONG.	WIDE.	LENGTH. BREADTH.
<i>Pis amnicum</i> , Herefordshire .. ..	6.4	4.7	1.36
	5.7	4.2	1.36
	7.4	5.6	1.32
	6.7	5.2	1.29
	8.0	6.4	1.25

(To be continued.)

SLIME FUNGI. I am collecting specimens and particulars of the Myxomycetes, or slime fungi, and think the best plan will be to ask for help through the pages of SCIENCE-GOSSIP. Will any botanist kindly assist me? W. H. Pepworth, The Avenue, Attleley Edge, Cheshire, September 27th, 1897.

## MAORI TATTOOING.

By JOHN T. CARRINGTON.

THERE are few better aids to the science of ethnology, in unravelling the origin of early civilization, than the study of tattooing. Though essentially a barbaric custom, in the patterns and manner of its production may sometimes be traced little suspected alliances of long separated races of mankind. The unfortunate part of the art as a record is, that the examples which would have aided most disappear with the decomposition of the skin after death. It is only in comparatively few cases that specimens have been preserved so as to be at present available for examination.

Notwithstanding a passing fashion among highly civilized people, which occasionally crops up even in such centres as London or Paris, where the professional tattooer thrives more or less successfully in these days, with the aid of electrically-driven needles and other delicate instruments, tattooing may be described as a disappearing art, excepting in some Japanese and South Sea Islands, where it still exists among the natives. It is therefore the duty of those ethnologists who study the progressive side of anthropology to secure and place on record for the benefit of posterity as much as can be gathered about tattooing. Not the least of these records is the beautiful book which Major-General H. Gordon Robley recently published<sup>(1)</sup>. In fact this contribution is one of the most important which have yet been published. The author's interest in the subject

was aroused so long ago as in the Maori war in New Zealand, of 1864-1866, when he served against that highly intelligent, brave, but then semi-civilized race. Since, he has steadily collected all possible information on the art of moko, or tattooing, as practised by the Maoris. His collection includes not only voluminous notes and many beautiful drawings made by himself, but undoubtedly the finest series of dried heads in existence. General Robley has not ended there, for

he has searched through most of the known museums and private collections for other specimens; and consequently not only thoroughly understands his subject, but has a record of nearly every head that has been saved.

The Maoris may have brought the art of tattooing with them when they occupied New Zealand, but though Tasman, on his hurried visit to the country in 1642, left minute descriptions of the natives seen by him, with some

drawings, he makes no mention of tattooing. It is probable moko was practised among the Maoris at that period, though Tasman has not noted the fact. Captain Cook, the celebrated English navigator, was the next who makes mention of the New Zealanders, when he visited the islands one hundred and twenty-eight years ago. At his visit, moko seems to have been in full fashion among the Maoris. Native tradition aids little towards the discovery of the origin of the practice among their ancestors. They believe, however, that it arose out of the custom of the warriors darkening their faces with charcoal by drawing patterns upon them. This required time and attention,



TE PEHI KUPO.

(1) "Moko; or, Maori Tattooing," by Major-General Robley, 212 pp. 3to, with 180 illustrations. (London: Chapman and Hall, 1896.) £2 2s.

so it seems probable that the fashion of cutting the patterns into the skin grew out of an attempt to make these warlike decorations of a more permanent character.

Sidney Parkinson, the artist who accompanied Mr. Joseph (afterwards Sir Joseph) Banks and Captain Cook, in 1769, has left the earliest known drawings of moko designs. From these the art seems to have progressed in the intricacy of pattern

always so, for there is evidence in later times that wealth and pride appear to have induced some to practice moko. Where no marks were visible on a man, it might be taken as certain that he was of little or no social consequence, or a slave.

Moko was practised on other parts of the body as well as on the faces of Maoris. The thighs and buttocks had especial designs, which seemed to have remained long in fashion. In General



MOKOMOKAI, OR DRIED HUMAN HEAD.  
(From the Collection of General Robley.)

up to the time it began to decline with the increased civilization of the Maoris. Even in Captain Cook's time we gather from his "Journal" that the patterns were the badge of grades of nobility or progress to chieftdom. This, it has been stated, was indicated by the upper lip, which in the case of chiefs only was tattooed, while the presence of moko in degrees indicated the rise to eminence of various members of the tribe. This was not

Robley's collection are pieces of dried skin of considerable size, taken from the thighs of men who lived in our own times, which show similar moko patterns to those drawn on Captain Cook's first visit. These thigh patterns are elaborate in the highest degree, and, like those of the face, wonderfully accurate in drawing. The thigh work extended, generally, from the knees to the waist, so that when the warriors were stripped

for battle, they had by no means a naked appearance, but looked as though clothed in trunks and breeches of beautifully artistic design. The patterns adopted by the Maoris were confined to the arabesques; in no case was the depiction of living forms known to have occurred. The lines are spirals, volutes and straight. The artist worked with a dyed chisel, the cutting and colouring going on at the same time. Similar designs were cut upon their wooden images, boats, etc., but whether for practice, for imitation, or whether the custom was of a sacred nature in its earliest conception, does not appear to be known.

Much care was exercised to keep the face clear of hair, so that every mark showed to advantage. This was necessary, if the different positions of the patterns were indicative of the rank of the wearer. Plucking of the hairs was the practice followed—they had no means of cutting—to keep face clean. Moko, as we have said, was a high the honour and source of pride. Not only did it for ever fix the rank, but the body or facial picture had a certain artistic value among the Maoris as personal adornment. To attain this condition awful ordeals must have been passed, when the artist had his patient at his mercy for weeks, months, and even years, in personal suffering without shrinking during the process of moko. This can be understood when we remember that suffering was of no account among these people, who revered him who had killed many in battle and eaten at least the eyes of his victims. That act was considered to have blended the living spirits of his slain enemies within the person of the conqueror. When such chieftain died, his own eyes were supposed to have floated up to the firmament and become stars. The brightest stars were named by the savage Maoris after their greatest chiefs.

Moko was practised to a limited extent on the women, with lines on lips, chin and occasionally on the forehead. The designs were simple in character, and never so elaborate as those of the men. The foreheads were less commonly tattooed, and mention has been made of other parts of the body having had patterns. When we consider what civilized females of the human race will suffer for fashion's sake, can we blame the Maori beauties for having their lips made blue and their dress-patterns inscribed on their skin by an artist, instead of supplied by a fashionable draper as in more modern times?

The moko process was one long agony for the operated. The artist had few tools, and those chiefly of bone, chipped, with razor-like edges. They were commonly chisel-shaped, and made to effect their work by tappings with a light piece of wood. Though generally of bone, the uhi, or chisel, was also made from sea-birds' wing-bones,

sharks' teeth, or hard wood worked down to a fine edge. Later, iron instruments were used and finer lines produced. The average breadth of the blade was about a quarter of an inch. The uhi has been known to cut right through the cheek, so that when the sufferer would take his pipe to ease the pain, the smoke passed through the slit. The pain was on all parts of the body, especially the lips, most excruciating. The torture did not end by immediate healing, for weeks afterwards the wounds would often fester and slough, causing the greatest suffering. The pigment used was largely made from charcoal of the Kauri pine, a veronica, and the fungus infected "vegetable caterpillar."

The designs selected for illustration by General Robley in his truly interesting book are in many cases most artistic, especially those of the foreheads. We reproduce a couple of the figures by permission of the author and publishers. The first is Te Pehi Kupo, a Maori who visited England in 1826. It will be noticed that he had not attained the chief's badge of a mokoed upper lip. The second figure is from a drawing of a beautifully-prepared head in General Robley's collection. It represents the mokomokai, or dried head, of some ancestor, friend, or enemy of its first possessor. The original is in the author's collection, the upper lip indicates a chief. The hair is in beautiful condition. There are many of these mokomokai in existence in museums and a few private collections. Fraud has been known among the dealers in them, and their choice required some technical knowledge. There are to be found examples of post-mortem art, made to cozen the unwary and uneducated collectors. From earliest intercourse between the Maoris and the European navigators, a trade was done in dried heads, the first head being obtained in 1770. If no dried specimen was available for barter, a chief has been known to parade his slaves, some of whom were tattooed for the purpose, for the buyers to select, and when the choice was made, the unfortunate was decollated and the head prepared and sent on board the ship.

The process of preserving mokomokai was first by steaming the head in a native oven. The soft material was all removed from the interior of the skull, the skin only being left. The skin was then brought into place, showing where the pattern had been worn in life. After plunging in cold water, the remains of the head were dried and smoked by a wood fire, which ended the process.

It may be mentioned that a portion of General Robley's collection is at present on view at the Guildhall Museum in London, where he has deposited it on loan. The exhibit occupied a case of considerable size, and is composed entirely of specimens of the art of moko, and other objects in its connection.

## CHAPTERS FOR YOUNG NATURALISTS.

(Continued from page 142.)

## LIVING LAMPS.

BY FRANCIS M. DUNCAN.

THE beautiful and mystic light which is to be seen playing over the surface of the sea and illuminating the waves as they break upon the shore, is known to us by the name of phosphorescence, and is produced by myriads of tiny creatures called Noctilucae—literally, night-lights. So minute are these creatures that a single specimen is but little more than visible to the naked eye. If we examine one of these specks of jelly, we shall find it almost a complete globe in form, provided with a whip-like process, or member, which is used as a means of locomotion. If watched, the light of *Noctiluca miliaris* will be seen to appear and disappear with considerable regularity, and should the animal be touched with a needle point, the light is quickly visible; just before death it becomes continuously luminous, the phosphorescence disappearing immediately after dissolution. Various interesting and curious experiments have been made with these little creatures, a goblet filled with them being used on one occasion as a lamp wherewith to read. A tube, fifteen millimetres in diameter, containing a bed of Noctilucae at the surface, twenty millimetres thick, emitted light sufficient to see the face of a watch and read the figures on the dial, and, when agitated, the little creatures were found to give sufficient light for the face of the watch to be clearly seen at the distance of a foot.

With this wonderful light there is no perceptible heat; the most delicate thermometers are not affected by it, and that it is not produced by combustion may be assumed from the fact that oxygen gas, when introduced, has not been found to restore the light after it has disappeared at the death of the animal.

Nearly all the jelly-fish or medusae become luminous at night, and are very interesting to watch as they move about in all directions, illuminating the depths of the sea with their mysterious phosphorescence; some emitting a pale greenish or steel-blue light, others crowned with a golden radiance. Some idea of the wonderful light emitted by the jelly-fish may be gathered from the description of *Muenopsis leidyi*, a highly phosphorescent form, by Professor Alexander Agassiz. He states that when passing through shoals of these medusae, the whole water became so luminous that "an oar dipped in the water up to the handle could be seen plainly on dark nights by the light so produced."

Let us now turn our attention to the floor of the sea, for here also living lamps abound, and could we but traverse the deep valleys and hills that are hidden beneath the surface, marvellous and awe-inspiring would be the sights that would meet our eyes: forests of luminous corals overhead, and at our feet phosphorescent ferns, flowers, and weird creeping things. The sea-anemones may well be called the flowers of the sea valleys; gorgeous in colour and varied form, some of these attach themselves to the shells of hermit-crabs, doubtless acting as beacons to attract prey. Many of these sea-anemones emit a brilliant light, and continue to do so even when brought to the surface by the dredge. One of the most brilliant is *Urticina nodosa*, which is generally found in ooze, its tentacles appearing at the surface, gleaming like the rays of a star.

The sea-fans and plumes, known by the family name of Gorgonia, and the sea-pens, or Pennatulidae, clothe the slopes and valleys of their aqueous world, filling it with the radiance of their lilac phosphorescence; forests of corals of varied hue uplift their graceful branches, amongst which fish of many shapes and sizes disport, many of them emitting a brilliant phosphorescent light of their own. Such is a brief outline of the marvellous living lamps to be found at sea, a moderate description of which would fill many portly volumes, and yet leave countless treasures undescribed.

Although the lamps of the sea are the most beautiful and varied, alike in colour and brilliance, still on land we find, both in the animal and vegetable kingdom, many living lamps which burn with vivid radiance. Probably the best known land-lamps are the glowworms (*Lampyrus noctiluca* and *L. splendidula*). Their light is due to phosphorescent particles concentrated in two or three of the abdominal segments. Kolliker and Macaire, the eminent anatomists, are agreed that the light-producing granules are of an albuminous nature, while Matteucci, by the aid of chemical analysis, has assured himself that they do not contain phosphorus. The female glowworm (*L. noctiluca*), is wingless, resembling closely the larva state of the species; but Nature, as if anxious to compensate her for the loss of aerial locomotion, has endowed her with a more brilliant light than that of the male. In many of the exotic species both sexes are winged, and it is a glorious sight on a dark night in the tropics, to see hundreds of

these brilliant light-givers flitting about and resting on the foliage, slowly moving and inter-crossing in the air, as they fly from tree to tree. In South America the fire-flies are frequently used for personal adornment, and when fastened to a lady's dress by means of a fine wire, give it the appearance of being bespangled with costly jewels. So steady and brilliant is the light produced by these insects, that clusters of them are used by the Indians, when travelling at night, to illumine and guide their footsteps through the forests, and we learn that during the conquest of Mexico, a swarm of these fire-flies were mistaken by the heated imaginations of the besieged for an army of matchlocks. Some of the centipedes or Myriopoda have been found to be highly phosphorescent, some of them having a luminous secretion, and leaving behind them quite a fiery trail.

The luminosity of the heron's breast is a remarkable phenomenon, and the probable use thereof has given rise to a good deal of speculation, one of the most likely theories being that the light emitted serves to attract the fish to the surface of the water, when they fall an easy prey to the watchful heron. The birds on which the phosphorescence has been observed are the night heron (*Nycticorax grisea*), and the blue crane (*Ardea caerulea*).

The mucus surrounding frogs' eggs has been frequently observed to give out a phosphorescent light, and was mistaken by the ancients, when seen in the luminous state, for masses of fallen meteoric ore. The eggs of the grey lizard have also been seen to emit phosphorescent light, and Dr. Carpenter mentions an amphibian inhabiting Surinam which is luminous.

In the vegetable kingdom we shall find a goodly number of lamps. Amongst the flowers of our garden, the nasturtium (*Tropaeolum majus*) was seen by the daughter of Linnæus to emit flashes of phosphorescent light in the gathering gloom of the evening, and at the dawn of day. The same phenomenon has been observed in the hairy red poppy (*Papaver pilosum*), the double variety of the common marigold (*Calendula*), the sunflower (*Helianthus annuus*), and the orange lily (*Lilium bulbiferum*). A plant found in Asia and South America, called *Euphorbia phosphorea*, emits when cut a milky juice which is brilliantly phosphorescent at night when heated, and by using a stem of the plant as a pen, the juice forms a luminous ink.

Probably the most familiar vegetable lamp is that known as "touchwood," or "foxfire," which is rotten wood permeated by the mycelium or spawn of fungi, which becomes luminous in the dark. Around the decayed arms of oaks, and old tree-stumps is to be found a most interesting luminous fungus, known as *Rhizomorpha subterranea*. It is also to be seen gleaming with a soft phosphorescence in caves and coalmines, sufficient light on some occasions being emitted to enable the reading of ordinary print. Besides this plant there are several other forms of fungus more or less luminous to be found in forests, woods, caves and churchyards, and no doubt these phosphorescent plants, shining with their mysterious bluish-green light, have played an important part as ghostly visitors from another world.

Lincoln Villa,  
Redhill.

## THE BRITISH MYCOLOGICAL SOCIETY.

THIS Society, which now numbers some forty-nine members, held its first annual week fungus foray in Sherwood Forest. The members assembled at Worksop on Monday, September 13th, when The Lion Hotel was constituted the head quarters. On Tuesday, September 14th, the woods on the Welbeck Estate were explored, but little of interest was discovered. In the evening, Mr. George Massee, F.L.S., F.R.M.S., delivered his presidential address on "Mycological progress during the past sixty years."

There were, said Mr. Massee, four great workers that stood out pre-eminent during that period, namely, M. J. Berkeley, A. de Bary, L. R. and C. Tulasne and O. Brefeld. Berkeley and Tulasne did their work by the "contiguity method," that is, they observed in the field that certain forms of fungi were almost always succeeded by other forms, hence they declared that these successive forms were but stages in the life-history of certain fungi,

and these assumptions have in many instances been verified by the more accurate pure culture growths that were initiated by De Bary and continued by Brefeld. In 1836 Berkeley was responsible for vol. v. of J. E. Smith's "English Flora," which dealt with fungi; therein is recorded the original observations of a worker, and since then no work on the subject has been anything else but a compilation, and not the result of original observation. In 1837 Berkeley first demonstrated that the Lycoperdeae and Phalloideae belonged to the Basidiomycetes, and he was the first to go into the life-history of the potato disease, *Phytophthora infestans*, the resting state of which is till this day a puzzle yet<sup>4</sup> unsolved by mycologists. Berkeley wrote over 325 articles on fungi, and was one of the first to trace out the life-history of the onion, vine disease, and many other mildews. In 1857, Berkeley published his "Introduction to Cryptogamic Botany," and he was the first person to



investigate the spores held in suspension in the atmosphere. To elucidate these, he smeared with glycerine the ordinary microscopic glass slide, suspended these slides at different times and elevations, and found on examination spores of mosses, fungi and bacteria, amongst many others; thus showing that the air was full of germs capable of growth upon a favourable habitat. This study has at the present day grown to be an exact science.

Mr. Massee next passed to the work of the brothers Tulasne, who issued their monumental work, "Selecta fungorum carpologia ea documenta et icones potissimum exhibens," from 1861 to 1865, showing the life-history of many groups of fungi, but their weak point was that they did not realize the presence of fungal parasites.

In 1853 De Bary first started the theory that fungi were descended from algal parents, and the beginnings of fungi were to be found in *Saprolegnia*, and numerous other aquatic genera, and that they were descended from *Vaucheria*, which had given up its chlorophyll and become a parasite. This undoubtedly was a downward proceeding, because the parasite was dependent on the host; but now fungi, owing to their adaptability to the environment, had to a great extent regained this loss.

Shortly after De Bary announced his discovery of heteroecism in *Puccinia graminis*, which is another form of *Uredo linariae* and *Aecidium berberidis*. De Bary was also the first to inaugurate the pure culture growths, which at the present day are regarded as the sole reliable evidence of the life-history of a fungus. These pure culture growths consist in placing a single spore on sterilized media from which all air or water is excluded unless previously freed from all germs whatsoever by special methods. De Bary further rejected the Myxomycetes from the domain of fungi because no hyphae were present.

Lastly, we come to the researches of Brefeld, 1872-1895, 12 vols., who would like to classify every fungus to one ideal cell, and argues that it is from the very lowest form of any given fungus that we obtain our highest forms, and shows that *Ptychogaster* is the conidial form of our Polyporeae, and other conidial forms are forms of higher fungi.

Mr. Massee then cited the smuts, *Ustilagineae* which he said Brefeld had germinated in an alkaline solution even after some years, and that the solution was equivalent to the host, the spores budded by gemmation, and were in this respect similar to *Saccharomyces*, but the interesting point was that this gemmation could go on for years in our manure heaps, but that infection of the host plant could only possibly take place on two days, viz., the first and second day after germination, the only exception being the maize.

Mr. Massee then briefly referred to the theory of sexual reproduction in the Basidiomycetes, which had been advanced by Dangeard and others, but dismissed it with the remark that no evidence in support thereof had as yet been forthcoming.

The election of officers for the ensuing season was then proceeded with, and Mr. George Massee, F.L.S., F.R.M.S., was unanimously elected President and Mr. Carleton Rea, B.C.L., M.A., was elected Hon. Secretary and Treasurer.

Miss Rose then exhibited a painting of a *Coprinus* new to mycologists, recently found near Worcester, called *Coprinus roseotinctus*, Rea, a technical description of which was furnished by Mr. Rea, and which is characterized by the deep-coloured rose meal on pileus and stem.

On Wednesday, September 15th, the mycologists explored the woods of Thoresby, and many interesting forms of fungi were secured, the most noticeable being in Budby Forest, where an *Entoloma* new to the British fungus flora, *E. hirtophyllum*, was discovered.

The members visited Clumber on Thursday, September 16th, and many specimens of fungi were collected. In the evening Dr. C. B. Plowright gave an interesting lecture upon the difference between *Ustilago jenseni* and *U. hordei*, which he illustrated by dry specimens. He clearly showed that these species of *Ustilago*, which have until recently been confounded as one, were most distinct. That the one was comparatively harmless, whilst the other, mixed up in threshing, was a deadly parasite. Mr. A. Clarke then read a Paper on "Photography as applied to Mycology." All were agreed that no abler exponent of that side of mycology could have been chosen to illustrate the varied forms of mycologic life. The last day, Friday, 17th, was devoted to an investigation of the oldest portions of the forest, now called the Birklands, and many interesting forms of fungi were there secured by the members.

Next autumn the British Mycological Society will hold its annual fungus foray in Ireland, having been invited to do so by the Dublin Natural History Society.

CARLETON REA.

24, Foregate Street, Worcester;  
October, 1897.

NORFOLK GLACIOLOGY.—We have received from Mr. W. Jerome Harrison, F.G.S., of 52, Claremont Road, Handsworth, Birmingham, a reprint from the "Glacialists' Magazine" a valuable paper, entitled "A Bibliography of Norfolk Glaciology." This bibliography includes the Cromer Cliffs, with the Forest-bed Series. The reprint occupies ninety-two pages, with an index and frontispiece. Mr. Harrison, it will be remembered, about a couple of years ago compiled a like list of the literature of the glaciology of the Midland counties. His plan includes a brief abstract from the papers referred to.

## ARMATURE OF HELICOID LANDSHELLS.

BY G. K. GUDE, F.Z.S.

(Continued from page 139.)

*PLECTOPYLIS pseudophis* (figs. 62a-c) from Thyetmyo, Pegu, was described and figured by Lieut.-Colonel Godwin-Austen, in the "Proceedings of the Zoological Society," 1874, p. 610, t. 74, figs. 3 and 3a. The shell is sinistral, disk-shaped, pale horny in colour, and widely umbilicated. The spire is a little elevated, and the suture slightly impressed. There are seven whorls, which increase slowly and

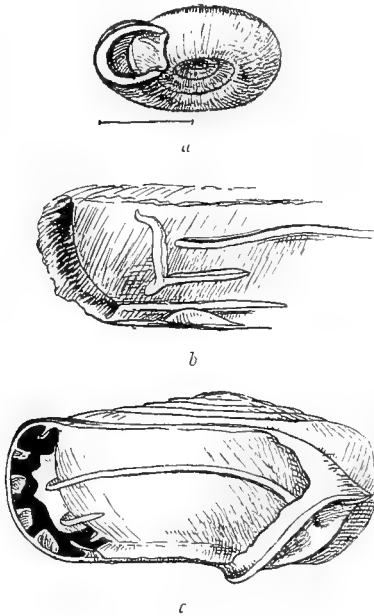

Fig. 62.—*Plectopylis pseudophis*. (a, original; b and c, after Godwin-Austen.)

regularly; the last whorl is subangulated above, rounded below, and descends rather deeply and suddenly in front. The aperture is rounded, and the peristome is thickened and reflected, the margins being connected by a raised flexuous ridge on the parietal callus, slightly notched at the junctions above and below. The parietal armature consists of a strong vertical plate, deflected posteriorly at the upper extremity, and giving off at the lower extremity an obliquely descending ridge posteriorly and a short horizontal fold anteriorly; the vertical plate is toothed in outline in the upper half, the teeth intercalating with three of the palatal folds (see fig. 62c). A long horizontal fold rises close to the vertical plate anteriorly, revolving as far as the aperture, where it unites with the raised flexuous ridge; a thin slight fold runs near to and parallel with the

lower suture (see figs. 62b and c, which shows the shell with part of the outer wall removed). The palatal armature consists of six simple short folds, the lowest three the longest and highest, the sixth much arched outwards (see fig. 62c). To my regret I have been unable to examine the armature of this species, having seen but a single specimen, which is in the British Museum; this is shown in fig. 62a; it measures—major diameter, 12 millimetres; minor diameter, 10 millimetres; altitude, 5 millimetres. Figs. 62b and c are copied from "Proceedings of the Zoological Society," 1874, t. 74, figs. 3 and 3a.

*Plectopylis brahma* (figs. 63a-c), from Brahmakhund, Eastern Assam, was described and figured by Lieut.-Colonel Godwin-Austen in the "Journal of the Asiatic Society of Bengal," xlviii. (1879), p. 3, t. 1, f. 3. The shell is sinistral, disk-shaped, pale horny-brown, finely and regularly striated, with a moderately wide umbilicus. The spire is slightly raised, and the apex is a little elevated. There are seven whorls, which are slightly convex, and increase slowly and regularly; the last is angular above, rounded below, a little constricted behind the peristome, and scarcely descending in front. The aperture is obliquely lunate, and the peristome is white, a little thickened and reflexed, the margins being connected by a scarcely raised curved ridge on the parietal callus; the ridge is notched at the junctions above and below. The parietal armature consists of a strong vertical plate having a short support posteriorly above and below, and giving off anteriorly at the lower extremity a short horizontal fold; above this are two free longer horizontal folds, the upper one rising close to the vertical plate, the lower one longer



Fig. 63.—*Plectopylis brahma*.

and rising a little further from the vertical fold. A minute denticle occurs between the second and third horizontal folds, and a horizontally elongated denticle above the upper extremity of the vertical fold; a very thin slight fold runs near to and parallel with the lower suture, uniting with the ridge at the aperture (see fig. 63c, which shows the

parietal wall with its folds). The palatal armature is in two series, the anterior one consisting of four elongated horizontal folds, the second and third being separated by a wider space than the others, while the posterior series is composed of thirteen or fourteen minute denticles arranged close together, some a little elongated. The shell figured is in the British Museum. It measures—major diameter, 8 millimetres; minor diameter, 6.5 millimetres; altitude, 4.5 millimetres.

*Plectofylis feddeni* (figs. 64a-d), from Prome, in the Pegu district of Burma, was described by Mr. W. T. Blanford in the "Journal of the Asiatic Society of Bengal," xxx. (1865), p. 75. The shell was figured in Hanley and Theobald's "Conchologia Indica" (1875), t. 131, ff. 1-3, while Lieut.-Colonel Godwin-Austen has illustrated the parietal armature ("Proceedings Zoological Society" (1874), t. 74, f. 7), and as I have been unable to obtain a specimen, I have copied these figures. According to Mr. Neville's Hand List, p. 71, the Calcutta Museum possesses specimens from Thyet-

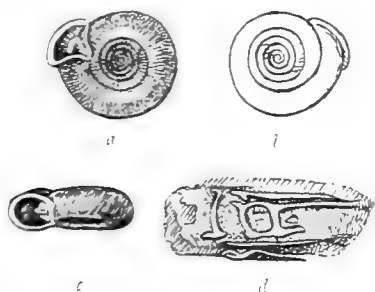

Fig. 64.—*Plectofylis feddeni*. (a-c, after Hanley and Theobald; d, after Godwin-Austen.)

myo. The description and figures referred to show that the shell is sinistral, discoid, very widely umbilicated, thin, whitish, irregularly and obliquely sculptured; the spire is plane and the suture impressed. There are six and a-half to seven narrow whorls, which increase slowly and regularly, and are a little convex above; the last is much wider, rounded at the periphery and base, and abruptly descends in front. The peristome is a little thickened and reflexed, and the margins are united by a raised flexuous ridge. From the middle of the ridge a horizontal, entering, interrupted fold is given off. The parietal armature consists of three vertical folds, of which the posterior one is longest and free, and gives off posteriorly at its lower extremity a short ridge; the two anterior ones are equal in length and are united by two horizontal folds, of which the upper one continues anteriorly to the ridge at the aperture, while the lower one is very short and projects only a little way beyond the first vertical fold; between these two horizontal folds, and close to

the anterior side of the first vertical fold, is found a small denticle. Above and below there is a similar free horizontal fold (see fig. 64d). The palatal armature consists of five folds, which are at first horizontal but become vertical posteriorly; the first and second are longer than the rest. The measurements are stated to be—major diameter, 16 millimetres; minor diameter, 13 millimetres; altitude, 4.5 millimetres.

(To be continued.)

## SCIENCE IN SOME MAGAZINES.

NOTICES BY JOHN T. CARRINGTON.

HARPER'S MONTHLY MAGAZINE (New York and London: October, 1897, 1s.). "Kilanea, the Home of Pele," by Professor William Libbey, is a beautifully illustrated popular scientific account of volcanic islands in the Pacific Ocean. Pele is the goddess of fire, fabled and mythical maybe to us now, but very real in times past to the early inhabitants of the Hawaiian group. The professor lands us at once in the midst of volcanic surroundings, and takes us over the floor of Kilanea, with its deep contraction fissures and rough surface. It is much as we should probably find the floor of the moon at the craters we so plainly see through our big telescopes, excepting that Kilanea is alive and the moon is dead and cold. The article is pleasantly written, and of considerable scientific value. In the same number Dr. Henry Smith Williams describes the "Century's Progress in Chemistry." The article is illustrated by portraits of John Dalton, Johan Jakob Belzelius, Joseph Louis Gay-Lussac, Justus von Liebig, Robert William Bunson, Louis Jacques Mandé Daguerre, and others. These portraits are worth all the cost of the magazine to the lover of chemical science. If that be not enough, there is a quaint cartoon of a student of bacteriology who has just discovered a funny microscopical cupid, which he is examining through a large lens.

THE CENTURY MAGAZINE (New York and London: October, 1897, 1s. 4d.). "What is an Aurora?" is the first article of a scientific character in this month's "Century." It is by Alexander McAdie. The illustrations are from telescopic photographs and explanatory diagrams. The object of the article is to associate three events of interest to mankind: sunspots, auroras and the price of wheat. It was, as most reading people know, Sir William Herschel who first drew attention to the consequent fluctuation of sunspots and the price of wheat. Professor Stanley Jevons long afterwards studied the association, and by tabulating the spots, auroras and commercial crises, made Herschel's hint bear fruit. It has been further discovered that sunspots do not come by chance—does anything?—but have a certain periodicity. The drift of the article is to teach the reader how our planet responds to solar disturbances and how the auroras are among the responses. G. T. Ferris tells us of the "Wild Animals in a New England Game-Park." He refers to the Corbin Game Preserve, a reserve of twenty-six thousand acres surrounded by a wire fence. This wild-things' paradise is part meadow, part forest and much mountain. In it are some four thousand head of big wild game, including

bison, deer of several kinds, bighorn, or Rocky Mountain sheep, moose, wild boar and some others. The illustrations of these animals and the sylvan scenery are charming.

THE LUDGATE MONTHLY (London: October, 1897, 6d.). Robert Machray's "Story of the Weather" opens with a portrait of Robert Scott, Esq., F.R.S., the Chief of the Meteorological Office in London. The story told is of the establishment of that now important institution and of the work it does for the public. It is very popularly told and would easily bear expansion, and though a scientific subject is not very scientifically treated. "The Rocking Stones of Cornwall" is a prettily illustrated account, by Archibald S. Hurd, of those remarkable stones which are ever attractive to the touring public.

THE ENGLISH ILLUSTRATED MAGAZINE (London: October, 1897, 6d.). "By Hedge, Stream and Spinney" is a chat with a squire's gamekeeper. It is a pleasant bit of country-lore by Young Stewart, illustrated with pictures of the keeper's surroundings. There is an interesting article on ballooning, which describes, with pictures, the long voyage from London to Weilburg, in Nassau, a distance of 500 miles, which was accomplished in eighteen hours in 1836. The aeronaut was Charles Green of ballooning fame, and he was accompanied by two private gentlemen, Robert Holland, M.P., and Thomas Monk Mason. It is an old story, but one well worth repeating.

THE GENTLEMEN'S MAGAZINE (October, 1897, 1s.) Mr. J. Ellard Gore, F.R.A.S., tells us about "The Distance of the Stars." He first treats his subject historically, and shows how far out in their calculations were the early astronomers. Thence he leads on the reader to the modern systems of measurement, which after all appear to be only approximate. The brightest stars are not, as a rule, the nearest to our earth. In "A visit to the Western Sahara," by Harold Bindloss, are several nature notes, and the article will well repay the time spent on its reading.

WESTMINSTER REVIEW (London: October, 1897, 2s. 6d.). "Bees and Flowers" forms the title of a chatty article by G. W. Bulman. He treats his subject quite from the literary side. While pointing out that many savants believe the colours of our wild and some other flowers have been produced by the selection of the bees, he at the same time rather grudgingly allows this. He doubts whether the "idea that we owe the colour and form of our flowers to insects, and chiefly to bees, can any longer be seriously maintained." The author is, perhaps, to some extent right, but his statements are, to say the least, of a sweeping character, and he appears to depend on others for his information.

WINDSOR MAGAZINE (London: October, 1897, 6d.). In this number Walter George Bell has an illustrated article upon "Trapping Planets," in which he describes some of the asteroids. In drawing the attention of his readers to the small size of some of these occupants of space, Mr. Bell remarks that "Great Britain, if rolled up into a sphere, would make a very respectable minor planet, or Ireland might be sent off on a career of absolute independence somewhere between Jupiter and Mars, where all minor planets circulate." That we venture to protest against, or where would the Irish emigrate. How America would miss them.



ALBINO SPARROW.—Mr. Fierke recently exhibited before the Hull Field Club an albino of the common house-sparrow, which was caught at Victoria Dock, Hull, this autumn.

LAMBETH FIELD CLUB AND SCIENTIFIC SOCIETY.—The Annual Soirée and Exhibition will be held at the Lambeth Wesleyan School, Lambeth Road, on Monday, November 8th, at 7.30 p.m. We are informed that the admission is by tickets, priced sixpence each. They can be obtained from Mr. H. Wilson, the Hon. Secretary, 14, Melbourne Square, Brixton.

THE COMING SOLAR ECLIPSE.—The expedition from the Lick Observatory will consist of Professor Campbell and some volunteer assistants, who will endeavour to photograph the spectrum of the reversing layer, as well as that of the corona, with a view to determining the rotation speed of the latter. If successful, these investigations should prove not only novel but a distinct advance in our knowledge of the sun's atmosphere.

EARTHQUAKE SHOCK.—In regard to Professor Milne's recent observations on earthquake shocks, I should like to place on record that on the night of February 19th and 20th, 1897, at 4.5 a.m., I was awakened by a loud noise in the basement, which in fact awakened the whole of the household. In a few seconds it was followed by a jingling as of hanging crockery downstairs, and this was accompanied by a noise in my bedroom as of a watch-chain dangling against the metal bed-post. I went downstairs and examined the place thoroughly, but could find nothing to account for the noise. I came to the conclusion there had been an earth-shock. I wrote to a London paper about it, but presumably it was not considered worth insertion.—*Edward A. Martin, F.G.S.*

OCTOBER IN CORNWALL.—On October 18th, we were favoured here with a brilliant sunny morning, warm, and with a light wind from the south-west. During a walk of a couple of hours I took on the wing *Colias edusa* (two males), *Pyrameis cardui*, *Polyommatus phloceus* (five in good condition), *Pieris brassicae* (two males); and saw *Pieris rapae*, *Pyrrarga egeria*, *P. megaera* and *Vanessa atalanta*. The following named wildflowers I also gathered: *Convolvulus arvensis*, *Papaver rhoeas*, *Viola canina*, *Taraxacum dens-leonis*, *Vicia sepium*, \**Rubus fruticosus*, \**Lonicera periclymenum*, \**Linaria vulgaris*, \**Potentilla reptans*, \**Linaria cymbalaria*, \**Bellis perennis*, \**Trifolium pratense*, \**Daucus carota*, \**Lamium amplexicaule*, \**Serratula tinctoria*, *Fragaria vesca*, \**Ulex europaeus*, \**Lychnis diverna*, \**Achillea millefolium*, \**Anagallis arvensis*, \**Knautia arvensis*, \**Scabiosa succisa*, \**Fumaria officinalis*, *Valeriana officinalis*, \**Apargia autumnalis*, \**Geranium robertianum*, *Viola tricolor*, \**Senecio jacobaea*, *Centaurea scabiosa*, *Erythraea centaurium*, and *Linum catharticum*. Those marked with an asterisk were fairly abundant. This is, I think, a very good list of insects and flowers for the time of the year, and proves the mildness of our county.—*W. A. Rollason, 13, Lemon Street, Truro, Cornwall.*

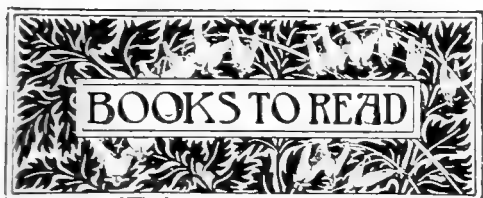

NOTICES BY JOHN T. CARRINGTON.

*A Memoir of William Pengelly, F.R.S.* Edited by  
HESTER PENGELLY, 341 pp. royal 8vo, illustrated

his time, and the instructor of princes. The book before us is the history of such a life, and in telling the story, if his daughter has erred, it has been on the side of modesty in raising this monument to her father's memory. Born at East Looe, Cornwall, in 1812, we may possibly find a clue to Pengelly's heredity of genius from his mother's side, whose maiden name was Prout, the celebrated water-colour artist, William Prout, being of her family. His father's descent was through a long line of seafaring men of courage and adventure. At twelve years of age the great geologist that was to be left school for ever and joined his father on board his little vessel. There he remained



REMAINS OF PREHISTORIC MAN FOUND NEAR MENTONE.  
(From "Memoir of William Pengelly.")

with portrait and 10 plates. (London: John Murray, 1891.) 2s.

The association of the name of William Pengelly, geologist of Torquay, with the early history of man in the British Islands has a world-wide reputation. His life is one of those examples which in these times of high education can rarely be expected to occur—where a man rises from lowly estate to be among the highest of his century's contemporaries. Indeed, it would hardly be too much to describe this notice, if a title were needed, as "From Common boy to F.R.S." Literally it is an education beyond that of a dame's school of the days; a teacher is a remote Cornish fishing village, William Pengelly's school, but certainly became the associate of the greatest intellects of

occupied in small coasting voyages, and associating only with rough uneducated men for some four of his most impressionable years. At the age of sixteen he left the sea, and for several years longer loafed about his native village, picking up a precarious living, but at the same time storing his mind with every scrap of knowledge he could attain in such a place as Looe, from the scanty literature available for a boy of his position, during the first quarter of this century. "My only chance," wrote William Pengelly of those days, "of obtaining a book was through an old pedlar who occasionally visited our village, and of him I bought my first 'Euclid.' Well do I remember the delight with which on one occasion I purchased twenty volumes of books at a second-hand shop at

Devonport,—ay, and the pride, too, with which I carried my treasure in a bundle on my shoulder to my native village home, sixteen miles across the Cornish hills." He tells, too, of the derision of his acquaintances and of the firm opposition of his parents. Even then his influence made itself felt. Some years afterwards he, with a few of the villagers, started an evening reading club in the dame's school. Their practice was for one to read aloud and the rest to listen and occasionally to question or criticise. It was there he met with one of his earliest references to the science that was later to make his name. Among the books to be read out was Dick's "Christian Philosopher," which contained a geological section. When the chapter was reached it was decided that as geology was very likely to be extremely dry, and as many good men thought it dangerous, if not decidedly infidel in its teachings, the chapter should not be read. While still very young he removed to Torquay, then little more than a village, and commenced to teach school in a small way. He introduced the use of chalk and blackboard, then hardly known in this country. The little class he then commenced, grew to one of the largest and most celebrated private schools in the country. It was in those early days of teaching that he met with the chapter on geology, which became the turning-point in his life. The casual reading of that chapter was the first step to the systematic study of the science which led to Pengelly's important researches into the cave deposits of Devonshire, such as Kent's Hole and Brixham Cavern. One of the first things which strikes one in studying the life of William Pengelly is his accuracy of his observation. It seems to have come to him largely with his geological studies. In the earlier days of them, he met Professor Jameson, of Edinburgh, who gave Pengelly a hint he never afterwards neglected. Jameson said: "On your return I shall ask you, 'Did you write your notes on the spot, or at the inn at the close of the day?' If you reply 'On the spot,' I shall be glad to hear them; but if not, I am afraid I shall not think them of much value." The following of that plan formed the habit of accuracy in all he undertook, which marked his whole after life. In one of the chapters before us are some amusing instances of his tests of accuracy in others. He used to remark, "I want to know what Mr. X *knows*, not what he thinks." Pengelly held, also, that these days are those of instruction, and not of education, the majority of scholars "being taught to be passive recipients of knowledge, rather than active enquirers." We feel sure he was right; for is not that what we daily see before us, as the result of the competitive examination. It is needless for us to place before the readers of this magazine any detailed account of Pengelly's geological work; it is far too well known. For those who desire to know more about it, there is at the end of this Memoir a chapter on "The Scientific Work of William Pengelly, F.R.S.," by the Rev. Professor T. G. Bonney, F.R.S., &c. From that and the list of his papers, which also is given in the Memoir, it is easy to judge how steady was his application and love for his favourite science. The book before us is largely built out of extracts from the private correspondence of Pengelly and that of his second wife, both of whom were delightful letter writers. Crisp, terse, and often amusing, one gets from these letters glimpses of the inner lives of men of science whose names are

now household words among us. Doubtless the passages quoted are by no means the most racy; and we trust others may find their way into print at some later period. With regard to the book itself, we need only say that it is produced in Mr. John Murray's best style as a publisher. The portrait which forms the frontispiece is a work of art. The plates are well printed and all interesting, and the one we reproduce by permission not the least so, though somewhat gruesome in subject. The memoir of William Pengelly should be read by every geologist, and be in every public library, as an example of England's finest types of men, those who have made her what she is among nations.

*A Critical Period in the Development of the Horse.* By J. C. EWART, M.D., F.R.S. 27 pp. 8vo, with 4 plates. (London: Adam and Charles Black, 1897.) 1s.

This is a very important subject to the breeders of horses, especially those of the higher classes. According to the Royal Commission on Horse Breeding, no less than forty per cent. of mares are liable to fail to produce offspring in any given year. The interruption usually occurs at from the sixth to the ninth week of gestation. Professor Ewart has attacked the problem, and he places the results of his investigations before us in this little book, illustrated by four well-drawn plates and seven elaborate figures of the embryonic conditions during the early stages of the horse. The subject appeals in the first instance to horse breeders, on account of the serious losses to which they are liable on account of their stock failing to produce young. It also appeals to the scientific embryologist as an important fact in the early conditions of foetal life. Professor Ewart's summary of causes for this breeding trouble among mares is very instructive, and makes us remember how sensitive an animal a horse really is.

*The Missouri Botanical Garden. Eighth Annual Report.* 236 pp. large 8vo, illustrated by 74 plates. (St. Louis, Mo.: at the Gardens, 1897.)

The Report of the Board of Trustees of the Missouri State Botanical Garden for this year is especially interesting to British botanists because of the admirable paper on "The Mosses of the Azores," by J. Cordot, which extends to twenty-five pages and is illustrated by eleven plates. This is followed by a paper on the general botany of those islands, by Professor William Trelease, illustrated by fifty-four plates. The Azores are a perfect paradise for botanists, on account of their delightful climate, where frost is unknown at the sea-level, though the higher mountains sometimes show that snow showers have fallen.

*The Story of Germ Life.* By H. W. CONN. 212 pp. small 8vo, with 34 illustrations. (London: George Newnes, Limited, 1897.) 1s.

This is another of the "Library of Useful Stories," published by Messrs. Newnes. It deals with bacteria, those important though lowly vegetable organisms which work so much of our "weal and our woe." The half-dozen chapters into which the work is divided give a concise history of bacteria, their uses in the arts, in the dairy, in natural processes, their relation to disease, and the modern methods of combating them when troublesome to mankind. This book is by no means the least interesting of the series of stories to which it belongs, and will do much to usefully educate many unthinking people, who will read it because small and cheap.

*John Hunter, Man of Science and Surgeon.* By STEPHEN PAGET. With Introduction by Sir JAMES PAGET. 272 pp. 8vo, illustrated by portrait. (London: T. Fisher Unwin, 1897.) Price 3s. 6d.

It was a happy thought of Mr. Fisher Unwin to produce a "Masters of Medicine Series" of books. This, the first of them, forms a good precedent, and Dr. Ernest Hart, who is the editor of the series, has been fortunate in his selection of subject and writer. The name of John Hunter is familiar to every educated Englishman. His originality and success, not only as a surgeon, but also as a teacher of anatomy and of physiological investigation, placed him high in the ranks of the masters of medicine. Dr. John Hunter is another example of unsuccessful boyhood producing a brilliant manhood. As a boy, he was comparatively a ne'er-do-well, and in later years himself wrote, with more force than elegance: "They wanted to make an old woman of me, or that I should stuff Latin or Greek at the University; but these schemes I cracked like so many vermin as they came before me." For all that, he was sent to Oxford; but a couple of months sufficed him, in his own judgment; for he left the University and returned to his tadpoles and caddis-worms, and pestering people with questions that nobody cared about. His elder brother William was then practising medicine in London, and John, after more waste of time in a timber yard at Glasgow, wrote to him and asked leave to come to work under him. Otherwise, John said he would enlist as a soldier. Fortunately for science and the good of mankind, William answered him kindly; so in September, 1748, the brothers joined each other in London. To the tact of the elder brother William, and the abundant common-sense lurking behind the misdirected youth of John, we owe the development of character in him who was later to become a factor in the alleviation of suffering, so prominently characteristic of modern surgery. In writing the book before us, Mr. Paget has relied largely upon family manuscripts collected by Miss Baillie, a descendant from the father of John Hunter on the female side. We have therefore an authority running through the pages which makes them more interesting. As a naturalist of the old school, John Hunter showed an independence of thought and of investigation, which, had it been followed by the biologists who succeeded him, would have hastened the present exact methods of scientific research. Still, two factors militated against John Hunter's natural science investigations. The greatest of these was his occupation in physiology, and perhaps not far less was the great development of acquisitiveness in his character. He was a collector above all things, and collected anything and everything when it in any way bore upon his favourite subjects. Perhaps it was well so, for did he not leave us the magnificent relics exhibited at the Royal College of Surgeons. Some of these are associated with quaint stories, not the least being that of O'Brien, the giant, whose body Hunter boiled in the kitchen copper of his own home at Earl's Court. The immense skeleton, prepared by Hunter's own hands, is one of the first specimens which attracts a visitor in the magnificent museum in Lincoln's Inn Fields. We shall look with pleasure for the appearance of other volumes of the "Masters of Medicine" series, which are to include William Harvey, Edward Jenner, Sir James Simpson, Hermann von Helmholtz, William Stokes, Claude

Bernard, Sir Benjamin Brodie and Thomas Sydenham.

*Through a Pocket-Lens,* by Henry Scherren, F.Z.S. 192 pp. 8vo, with 90 illustrations. (London: Religious Tract Society, 1897.) 2s. 6d.

This is one of those admirable little works on natural history which are issued by the Religious Tract Society. They circulate largely in schools and other ways among young people, creating a taste for enquiry into healthy subjects, and those easily found. With this little book and an inexpensive pocket-lens, the young student, whether boy or girl, will find abundant food for mind, and recreation for many a year to come. Neither are the subjects "dry," for the more we get to know, the more we naturally desire to find out. Mr. Scherren, very wisely, has contented himself with telling his readers about the commoner objects with which they are likely to meet in country rambles. These he selects with judgment, and with the illustrations, has compiled a book useful to both young and old rambles in country lanes and fields.

*Medical Botany.* By William Trelease, Sc.D. 12 pp. 8vo. (Chicago: American Medical Association Press, 1897.)

This little pamphlet is a reprint from the "Journal of the American Medical Association" of September 4th, 1897, and formed a paper read before the section of *Materia Medica*, at the forty-eighth annual meeting of the Association, in June last. Dr. Trelease commences at the very beginning of the subject of the use of plants as medicine. He says: "Prior to emergence from its nameless pre-barbaric state, the human race was undoubtedly versed in botany of a strictly practical kind." This he supports by reference to the use by other animals of some plants as antidotes. In the paper before us the author reviews the whole subject of medical botany and the pharmaceutical value of herbs brought to the aid of the scientific physician in more recent times.

*The Machinery of the Universe.* By A. E. DOLBEAR, A.B., A.M., M.E., Ph.D. 122 pp. 8vo, illustrated by 16 figures. (London: Society for Promoting Christian Knowledge, 1897.) 2s.

This is one of the "Romance of Science Series" of the S.P.C.K., and deals with the transformation of energy from one form to another. There are only three chapters in this small work, which is necessarily sketchy in character, but will be useful to those who know little of the phenomena with which it deals. The subject is one of enormous magnitude, and of course, to a large extent, speculative, but will be found, as treated by Professor Dolbear, interesting enough for general reading. It deals with the infinitely great and the infinitely small.

*Descriptive Catalogue of Useful Fibre Plants of the World.* By CHAS. RICHARDS DODGE. 361 pp. large 8vo, illustrated by 13 plates and 103 figures in the text. (Washington: Government Printing Office, 1897.)

Although this is really a catalogue, it contains so much valuable descriptive matter that it becomes a treatise upon plants, the fibre of which has been used for commercial purposes. These number no less than 1,018 species. Many of them are figured in the letterpress, and there are numerous others on the various plates. The descriptive matter, to which we have already referred, varies in length from a line or two to several pages, according to the importance of the species under notice.





THE next International Geological Congress will be held at Paris in 1900, during the time of the exhibition.

ON Tuesday, September 28th, an anniversary service was held at the Pasteur Institute in honour of the great investigator.

PROFESSOR G. H. DARWIN, F.R.S., and the Right Hon. G. J. Goschen, M.P., have been elected foreign members of the *Accademia dei Lincei*.

DR. CHARLES SMART ROY, F.R.S., of Trinity College, Professor of Pathology in the University of Cambridge, died on October 4th. He was forty-three years of age.

A MONUMENT in bronze, erected to the memory of Marcello Malpighi, the eminent Italian anatomist and botanist of the seventeenth century, was unveiled at Crevacore, near Bologna, on September 8th.

IT is reported that an important advance has been made in colour photography, by Dr. Adrieu Michel Dausac and M. Villedieu Chassagne. The process is said to be simple and inexpensive.

WE have to announce the death of M. Mojsisovics von Mojsvar, Professor of Zoology at the University of Gratz. This author, amongst other works of an important nature, wrote one on *Zootomy*.

THE X rays are now being used in French custom-houses, for the detection of fraud; but photographers carrying plates among their luggage are complaining of their being spoilt in consequence.

A LINE of electric tramways has been recently opened in Alexandria. This line, which has been constructed by a French firm, runs through the town of Alexandria as far as the last village before the desert.

THE Greek Archaeological Society has secured possession of a quarter of Athens lying immediately under the Acropolis. The inhabitants will remove to the suburbs, and excavations, promising important discoveries, will begin shortly.

THE third edition of the Catalogue of the Tate Public Library at Streatham has been sent to us, and shows a marked interest in scientific books, which are now well represented in that excellent institution.

IT will be remembered we took exception in the first volume of the new series of *SCIENCE-GOSSIP* to the class of science books in some of our free libraries as being largely out of date. Since then there has been a steady improvement in some of them, though in many there is still much to be desired.

ON paying a recent visit to look over the immense stock of scientific books at Wheldon's, in Great Queen Street, London, we wondered that this should be so, for Mr. Edwards, the proprietor of the business, would readily assist in filling up the gaps in some departments which are at present hardly represented.

THE Smithsonian Institution, Washington, has undertaken an important work in bringing together all possible material bearing on the medicinal use of plants in the United States. Dr. V. Harvard is Chairman of the Commission for this purpose.

THE new Government Laboratory in London, attached to the Inland Revenue and Crown Contracts Departments, was opened on 1st October last. It is in Clement's Passage, off the Strand, and has been erected and equipped in the most perfect manner at a cost of nearly £30,000, under the supervision of Professor Thorpe.

A REMARKABLE discovery has been made near Perm of an extensive burial place of the supposed old inhabitants of Russia, the Chuds, in which exceedingly rich collections of implements have been discovered. Among them are a number of broken pieces of earthenware ornamented with all sorts of figures illustrating the life of the people.

THE handsome gifts to Owens College, Manchester, of £50,000 from Mr. R. C. Christie, and the £10,000 from two anonymous donors, will be expended, the first upon a college hall, and half the latter sum upon a building for a physical laboratory, the remainder to be invested towards its maintenance.

WE regret to hear of the discontinuance of the "International Journal of Microscopy and Natural Science." After producing that excellent magazine for some sixteen years, Mr. Alfred Allen is obliged to abandon its publication for want of support. This makes no difference in the arrangements of the Postal Microscopical Society.

THE Marine Biological Association of the United Kingdom, in its Journal, prints a list of periodicals and monographs urgently required for the library of the Plymouth Laboratory. Anyone assisting in furnishing some of these papers will be aiding valuable work. A list may be obtained from E. J. Allen, Esq., the Biological Laboratory, Plymouth, England. They are chiefly by foreign writers.

THE Commission du Musée d'Histoire Naturelle, at Geneva, has formed itself into a committee with the object of erecting a statue to the memory of François Jules Piclet de la Rive. A site has been granted in front of the museum. Old students and all who are interested in the work which he accomplished are invited to send subscriptions to the memorial fund to MM. Lombard, Odier and Cie, Geneva.

THE "Russian thistle" (*Salsola kali*), concerning the introduction and spread of which in the United States and Canada much alarm was expressed, appears from reports lately received from the Western States to be a comparatively harmless pest after all. It does not thrive so well as appeared likely, but declines somewhat after a year or two. The dried weed has been chopped up in some districts and given as food to cattle. It has also been used for fuel and is said to be marketable for that purpose.

By the death of the Rev. Andrew Matthews, we are reminded of much important entomological work executed by him, especially in connection with the Trichopterygia of both Europe and America. The late Mr. Matthews was of a retiring temperament, and spent most of his time quietly attending to his parish duties at Gumley, near Market Harborough, where he died on September 14th last, aged seventy-two years.



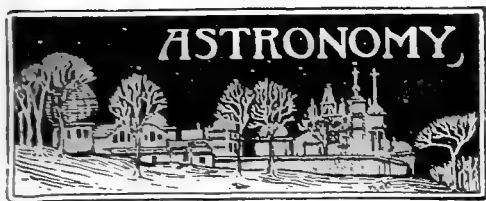

**ASTRONOMY**

CONDUCTED BY FRANK C. DENNETT.

		Rises.		Sets.		Position at Noon.	
		h. m.		h. m.		R.A. Dec.	
Sun	Nov. 3 ...	7.0 a.m.	4.28 p.m.	14.36	15° 15' S.	15° 15' S.	
	13 ...	7.17	4.12	15.16	18° 8'	18° 8'	
	23 ...	7.34	3.59	15.58	20° 29'	20° 29'	
		Rises.		Sets.		Age at Noon.	
		h. m.		h. m.		d. h. m.	
Moon	Nov. 3 ...	2.11 p.m.	7.43 p.m.	0.15 a.m.	8 12 32	8 12 32	
	13 ...	6.48	2.55 a.m.	11.16	18 12 32	18 12 32	
	23 ...	6.34 a.m.	10.46	2.48 p.m.	28 12 32	28 12 32	

		Souths.		Semi		R.A. Dec.	
		h. m.		Diameter.		h. m.	
Mercury	Nov. 3 ...	11.33 a.m.	2" 4	14.25	13° 48' S.	13° 48' S.	
	13 ...	11.56	2" 3	15.28	19° 16'	19° 16'	
	23 ...	0.22 p.m.	2" 4	16.33	23° 29'	23° 29'	
Venus	Nov. 3 ...	10.11 a.m.	5" 7	13.3	4° 55' S.	4° 55' S.	
	13 ...	10.8	5" 5	13.49	9° 35'	9° 35'	
	23 ...	10.26	5" 4	14.37	13° 54'	13° 54'	
Mars	Nov. 13 ...	11.54	1" 9	15.26	18° 51' S.	18° 51' S.	
Jupiter	Nov. 13 ...	8.42	15" 1	12.13	0° 12' S.	0° 12' S.	
Saturn	Nov. 13 ...	0.29 p.m.	7" 0	16.1	18° 51' S.	18° 51' S.	
Uranus	Nov. 13 ...	0.15	1" 8	15.47	19° 44' S.	19° 44' S.	
Neptune	Nov. 13 ...	1.55 a.m.	1" 2	5.25	21° 49' N.	21° 49' N.	

MOON'S PHASES.

		h. m.		h. m.	
1st Qr.	Nov. 1 ...	2.37 p.m.	Full	Nov. 9 ...	9.50 a.m.
3rd Qr.	Nov. 17 ...	2.2 p.m.	New	Nov. 24 ...	9.20 a.m.

In apogee, November 11th, at 10 a.m., distant 252,500 miles; and in perigee on 24th, at 3 p.m., distant 221,700 miles.

CONJUNCTIONS OF PLANETS WITH THE MOON:

Nov. 13 ...	Ceres	12 p.m.	planet	0° 20' S.
20 ...	Jupiter†	4 p.m.	"	6° 9' N.
23 ...	Venus*	3 a.m.	"	6° 39' N.
24 ...	Mars†	9 a.m.	"	4° 4' N.
24 ...	Saturn†	12 a.m.	"	5° 57' N.
25 ...	Mercury†	2 a.m.	"	2° 0' N.

\* Below English horizon. † Daylight.

THE SUN should be watched for spots, traces of considerable activity being frequently visible.

MERCURY, being in superior conjunction with the sun at 5 a.m. on November 7th, is too close for observation this month. This is unfortunate, seeing it is in conjunction with Mars, Uranus and Saturn on the 12th, 16th and 18th, being only 21' south of Mars at 7 p.m. on the 12th

VENUS is still a morning star, rising at 4.27 a.m. on the 1st, and 5.57 a.m. on the 30th. Its angular diameter is gradually contracting, and its form more nearly approaching a circle.

MARS, SATURN and URANUS are in superior conjunction on November 21st, 8 p.m. and 1 a.m., and 25th, 7 a.m. respectively, and so are too close to the sun for observation. Mars is in conjunction with Uranus, only 24' south at 9 a.m. on the 21st, and with Saturn at 7 a.m. on the 27th

JUPITER is a morning star, rising about 3.13 a.m. on the 1st, and 1.48 a.m. on the 30th, its path taking it close south of the 3rd-magnitude η Virginis. Its diameter is increasing, and the phenomena of its belts and satellites most interesting.

NEPTUNE rises early in the evening, and is situated between the "crab" nebula and the 5th-magnitude 114 Tauri

METEORS should be looked for, particularly on November 1st, 2nd, 4th, 6th-9th, 11th-15th, 19th and 27th. Mr. W. F. Denning, of Bristol, expects an abundant display on the morning of the 14th, a repetition of that of 1864, though possibly not so brilliant. The radiant point is R.A. 10h. and Dec. N. 23°, hence they bear the name of Leonids.

RED STARS IN POSITION DURING NOVEMBER:

	R.A.	Dec.	Magnitude.	
	h. m.			
α Tauri, Aldebaran	4.30	16° 18' N.	1	
β 51 Camelopardi	2.47	68° 50' N.	6.5	Variable, fine
β 65 "	3.32	62° 15' N.	6.6	red
β 83 "	4.39	67° 57' N.	7	
π III. 97 "	3.32	59° 33' N.	6	Orange red
- Camelopardi	3.48	60° 50' N. ±	5	
- Tauri	4.17	20° 30' N. ±	6 or 7	Fine red
- Eridani	3.39	10° S. ±	8	Closely N., following δ

SATURN'S RING SYSTEM.—From Lick Observatory it is reported that Professor J. M. Schaeberle has observed a division of the middle, or B, ring of Saturn, only 0.7" from its inner edge, about equal in width to the Cassini division between A and B. It is not a black division, and in a poor air is very apt to be overlooked. It appears to be vaguely indicated in De la Rue's drawing reproduced in Smyth's "Speculum Hartwellianum." Schaeberle, however, cannot see the division between B and C, announced by Herr Leo Brenner, and which was seen by Dawes in 1852-3 and Secchi in 1855. Brenner, writing to the "Observatory," reports the recovery of Otto Struve's (1851) division of the crape veil, or C, which was seen also by Struvaert in 1887. Brenner also speaks of a new division of A, inside the Encke division, which at the time of observation was more conspicuous than Encke's. Divisions have been observed on the inner part of A by Kater, 1825, Secchi, 1855, as well as suspected by others. These observations prove what constant change is taking place amongst the particles which go to make up this magnificent appendage.

AUGUST METEORS.—Professor A. S. Herschel contributed an interesting article on "Outlying Clusters of the Perseids" to the October number of "Nature." The same number notices photographs of a meteor taken by Professor E. E. Barnard. The plates were exposed in two cameras on the mornings of August 10th, 11th and 12th. The meteor trail was from R.A. 2h. 59m., N. Dec. 23°-7, to R.A. 2h. 59m., N. Dec. 32° 0. Near the southern end of its path the meteor—which must have been brilliant—appears to have exploded; the trail—much fainter—is continued about 1° further in the same direction, when a second minor explosion seems to have taken place. On a photograph taken by Mr. Butler some two years since, the direction of the meteor's trail was changed after the explosion.

VENUS.—M. Camille Flammarion contributed the first part of a useful article on "Some New Views as to the Planet Venus" to the October number of "Knowledge." On examining the illustrations we were struck by the remarkable agreement between the three drawings taken by MM. Antoniadi, Mathieu and Flammarion, at Juvisy, 1879, July 14th, the first two at 22h. 15m., the third fifteen minutes later. Again, there is a remarkable agreement between those by Sir W. Herschel, 1780, June 19th—taken apparently with a front view reflector—and M. E. A. Antoniadi, 1897, June 23rd, 21h. 45m.

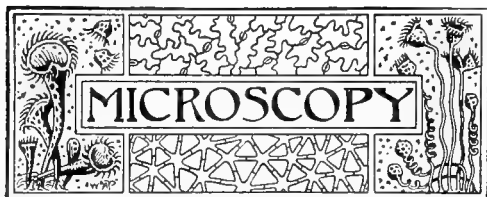

CONDUCTED BY J. H. COOKE, F.L.S., F.G.S.

To whom Notes, Articles and material relating to *Microscopy*, and intended for SCIENCE-GOSSIP, are, in the first instance, to be sent, addressed "J. H. Cooke, Thorndale, Lincoln."

**A NEW FILTERING MEDIUM.**—A German chemist has found that powdered pumice-stone is an effective filtering medium for liquids containing precipitates that are likely to pass through paper.

**A NEW MICROSCOPIC WORM.**—A new worm, living in colonies in the roots of asters, and popu-

a value of £50 to £120 per pound. Little weight is lost in the process, and it is not a case of slow desiccation which can be imitated or accelerated by the withdrawal of water. In the course of his researches, M. Beauregard has found that the change is due to a microbe, which he names *Spirillum recti Physteris*, and which appears slowly to destroy the offensive odour and to produce the delicate perfume. It has not yet been determined whether this microbe is capable of producing disease in the whale or in man.

**ATMOSPHERIC DUST.**—In the September issue of this journal, Dr. J. O. Symes gave us some interesting details bearing on the constituents of atmospheric dust. To supplement this paper we now reproduce some micro-photographs of dust-particles, which Dr. J. B. Cohen submitted with his lecture on "The Air of Towns" to the Smithsonian Institution in the prize competition for the Hodgkins Fund. Fig. 1 shows some of the objects composing the dust of a dwelling-room, highly

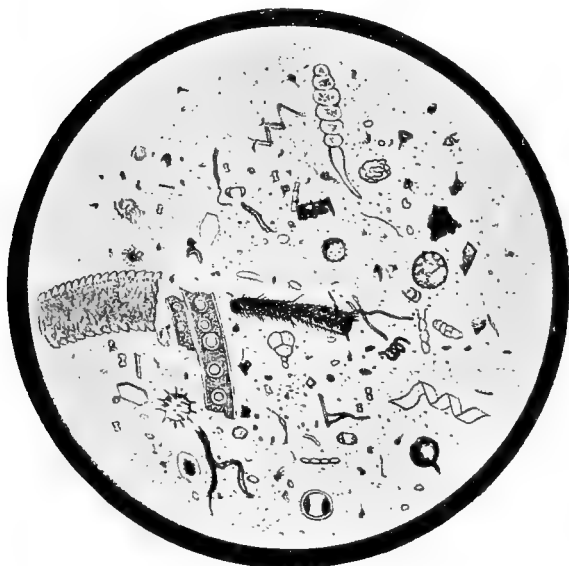

Fig. 1.—DUST PARTICLES IN THE AIR. (Highly magnified).

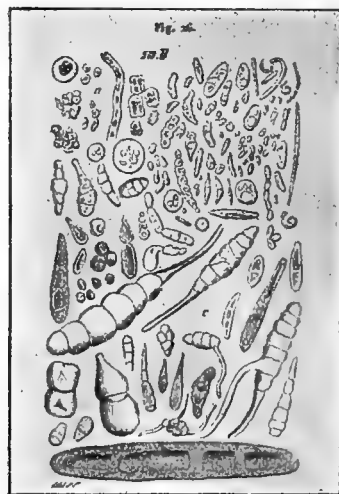

Fig. 2.—ATMOSPHERIC MICROBES.

larly known as the "aster-worm," has been described by the Rev. Hilderic Friend, of Tipton, under the scientific name of *Enchytraeus parvulus*, Friend. It is the most minute member known of the order including the earthworms. Its length is only about an eighth of an inch, yet it has thirty segments, the first six or seven of which are pellucid.

**THE MICROBE OF AMBERGRIS.**—Ambergris has been already shown by Professors G. Gouchet and H. Beauregard to be an interesting calculus which is developed in the rectum of the sperm whale. A microscopic examination has shown this calculus to be composed of crystals of ambrine mixed with varying proportions of a black pigment from the rectal lining, and with star-coral débris. When freshly removed it is soft and not at all pleasant in odour, but after preservation in an air-tight tin case for some years, the faecal odour is lost or transformed into an agreeable perfume that gives the material

magnified. They consist of particles of soot, crystals, fibres, vegetable cells, spores and pollen grains, starch grains and meteoric iron; all of which are so minute that it has been calculated that it would take forty million million to weigh one grain. In fig. 2 we have some of the results of the researches of M. Miquel at the Observatory of Montsouris, near Paris, on the air of that city. He has examined the street dust, the dust of rooms, the air from the sewers, and from the top of the Pantheon, high above the town—in short, the dust of every possible place where disease germs might lie.

**STREET MICROBES.**—The number of microbes in the streets of Paris is on the average about twenty-one to twenty-two in the cubic foot. In Dundee, Professor Carnelley found twenty in the cubic foot. Outside Paris the number falls off to two, whereas, in dirty, one-roomed houses, Carnelley found 3,430, and Miquel, in a neglected hospital ward, 3,170 in the cubic foot. Dr. Cohen

conducted several experiments on the air of school-rooms, the results of three of which are well illustrated in fig. 3. Experiment *a* was made before the school assembled, *b* in the middle of the day, and *c* when the school was closed.

**SPONGE SPICULES.**—The common freshwater sponge, *Spongilla fluviatilis*, contains spicules of two forms, one with two discs like serrated wheels united by an axle, the other slightly curved, pointed at each end, and rough on the surface. They are silicious, and may be separated by the use of nitric acid. Another sponge, *Grantia compressa*, which is very small and white, and is usually to be found attached to seaweeds, contains two forms of spicules, both of which are calcareous. In this case liquor potassae must be employed to obtain them. One form is tri-radiate, and the other club-shaped at one end and pointed at the other. The spicules of both sponges are very beautiful in form, and would well repay the time spent in extracting them.

**NERVES OF MOUSE'S EAR.**—There is no cutaneous structure throughout the entire mammalian series that is so richly supplied with nerves as is the ear of a mouse. It has been estimated that one ear contains about 12,000 nerve-knots. On dividing the cartilage of the ear horizontally, so that the ear is split into two lamellae, no less than four nerve plexuses may be seen in each. Lying on the cartilage are the larger trunks, which usually divide dichotomously, and intercommunicate in seven different fashions. The second layer, like the first, is composed of medullated fasciculi of smaller size, freely intercommunicating with each other, and lying immediately beneath the capillaries. The third layer is composed of still finer medullated fasciculi, and is on a level with the capillaries. Small fasciculi of this layer, composed of from two to four fibres, run to hair follicles, and, having encircled each with one or several turns, terminate in a little nervous coil, knot, or glomerulus at its base. The nerve-knots are spherical with a diameter of about 0.015 of a millimetre, and they occasionally include a few ganglion cells in their interior.

**MOUNTING HAIRS.**—Hairs should be washed (not soaked) in liquor potassae, cleansed in alcohol and water, thoroughly dried, and finally soaked in turpentine for several days. They may then be mounted in the usual way in balsam.

**PREPARATION OF BALSAM FOR MOUNTING.**—In the course of a paper on the technique of microscopic manipulations, which has been published in the "Transactions of the American Microscopical Society," Dr. Fish offers some valuable suggestions

on the preparation of balsam for mounting. Balsam in its commercial state contains many volatile principles and traces of acids, which in the course of time act upon the specimen and diminishes or entirely removes the colour. All this may be lessened if the balsam be heated sufficiently to drive off the volatile constituents, or more thoroughly obviated if a little potassium-carbonate or mild alkali be added to neutralize the acid just before the balsam is heated. When the balsam becomes hard it can be broken into flakes and stored. When wanted for use dissolve in xylol to the desired consistency and filter through absorbent cotton.

**SEPARATION OF DIATOMS, MINERAL PARTICLES, ETC.**—For the above purpose the "Zeitschrift für Angewandte Mikroskopie" recommends the following liquids of high specific gravity: Brown's Liquid (methylene iodine), which has a specific gravity of 3.3. By adding iodoform to this, this figure is raised to 3.45, whilst iodine increases it to 3.65; Klein's Liquid (potassium-boro-wolframin),

the specific gravity of which is 3.28; Rohrbach's Liquid (barium-mercury iodine), specific gravity 3.58; Toulet's Liquid (sodium-mercury-iodine specific gravity 3.19. All of the above are soluble in or miscible with water in every proportion. In using them the material is thrown on the liquid, which floats or sinks according to its specific gravity.

**A MYSTIFYING FUNGUS.**—The reproduction of the truffle is a perplexing problem for microscopists. Some land-owners of Lot and Correze have

been experimenting to determine whether the spores are not diffused through the intermedium of cattle, and particularly of certain domestic animals of quick digestion, but M. Grimblot seems to have proved that the diffusion of the spores is effected by wood-mice. This throws doubts upon another common belief, that both this valuable fungus and the common mushroom produce spores which will not develop until passed through the intestines of a cow or horse.

**GLYCERINE.**—Glycerine, either pure or mixed with water or alcohol, is frequently used to preserve the larvae of delicate insects. It preserves the colour and form better than alcohol, but particularly in the case of larvae it causes a softening of the tissues, unless great care be observed.

**MICROSCOPICAL STUDIES.**—In answer to the query (*ante* p. 148), Mr. James Hornell has completed his first series of botanical slides, with descriptive letterpress, and illustrated by micro-photos, and the second is now about ready. He has also a like series illustrating marine zoology.

Edwin E. Turner, Coggeshall, Essex

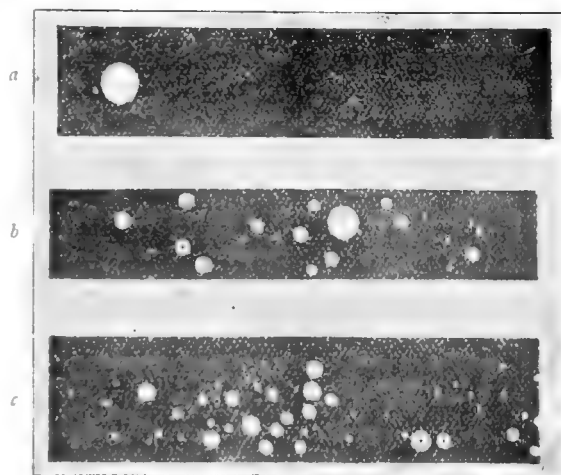
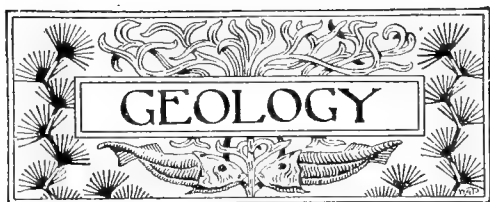

Fig. 3.—MICROBES IN AIR OF SCHOOLROOM.  
*a*, algae; *b*, cells of cryptogams; *c*, spores of cryptogams.  $\times 500$ . (Miquel.)



CONDUCTED BY EDWARD A. MARTIN, F.G.S.

To whom all Notes, Articles and material relating to Geology, and intended for SCIENCE-GOSSIP, are, in the first instance, to be addressed at 69, Bensham Manor Road, Thornton Heath.

**GEOLOGY IN SCIENCE-GOSSIP.**—We have pleasure in announcing that the kind offer of Mr. Edward A. Martin, F.G.S., author of "The Story of a Piece of Coal," etc., to conduct this section of SCIENCE-GOSSIP, has been accepted.

**GEOLOGICAL RECORDS OF SOUTH-EAST ENGLAND.**—Mr. H. E. Turner, Bank Street, Ashford, Kent, the Hon. Secretary of the South-Eastern Union of Scientific Societies, has issued particulars of a new section of the Union that has recently been organized for the following objects: (1) To stimulate interest in the observation and recording of geological phenomena; (2) to form annually a set of lantern-slides dealing with some part of the geology of the south-east of England, and to circulate these, with an explanatory lecture, among the affiliated societies during the winter session; (3) to form a permanent collection of geological slides and photographs; (4) to contribute to the national collection of geological photographs now being formed at Jermyn Street Museum under the auspices of the British Association.

**MICROLITES AND TRICHITES.**—The incipient forms of crystallization which are met with in the glassy magma of the vitreous rocks are among the most beautiful of the many forms that the petro-



FIG. 1.—THIN SECTION OF RED OBSIDIAN.

logist meets with in his microscopical examinations. Thin sections of obsidian, when seen under the microscope, become perfectly transparent, and

are crowded with minute, transparent, pale-green crystals and short, black, hair-like bodies called trichites (fig. 1). The crystals are in thin rhombic tablets, or irregular grains,  $\frac{1}{5000}$ th of an inch in diameter, either scattered about or strung on the short, opaque threads, like conserved cherries on a straw. The larger of these microscopic crystals, known as microlites, is generally a variety of augite, which only appears in microscopic forms in this rock. The trichites are about  $0.000032$  of an inch wide, and it is these that give the obsidian its black colour. Such microlites and trichites are found in nearly all volcanic glasses, and differ in shape and character according to the condition and composition of the lavas in which they occur. They are rudimentary crystals of minerals which develop in rapidly-solidifying glasses, where a larger and more perfect crystallization is hindered by the viscosity of the glass. Some of the red obsidians derive their colour from bright red trichites and grains, due probably to

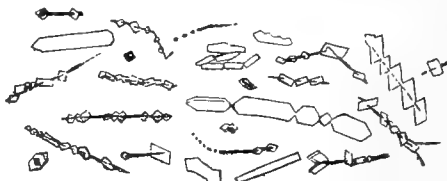

FIG. 2.—MICROSCOPIC CRYSTALS IN OBSIDIAN.

the higher oxidation of the iron (fig. 2). The coloured ribbons and streaks to which these often give rise produce very grotesque and curious shapes, among which one recognizes the forms of flowers, toad-stools, sea-anemones, jelly-fish, spear-heads and the like, a list only limited by the size of the thin section and the imagination of the observer.

**UNDERGROUND FUEL.**—Few scientific deductions are more striking than the recent one of Lord Kelvin on the world's underground fuel supply, much of which is still hidden. Coal is the residue of ancient vegetation, and the oxygen of the air was probably largely derived from this vegetation, which experiment shows must have furnished three tons of oxygen for each ton of coal. This is the proportion of oxygen consumed in burning coal. The surface of the earth has an area 510 million millions of square metres, each square metre bearing ten tons of air, of which two tons are oxygen, and a simple calculation shows with great probable accuracy that the total fuel supply in the world is 340 million millions of tons. It was determined, in 1831, that England, Scotland and Wales had 146,000 millions of tons of coal surely available with 56,000 millions of tons more possibly available. This is more than Britain could burn with its own air, having therefore more than an average coal supply.

**THE PROBLEM OF DIAMOND MAKING.**—The method proposed by Herr E. Moyat for producing large artificial diamonds consists essentially in sealing pulverized coal, iron chips and liquid carbonic acid in a strong steel tube and submitting them to the action of the electric arc. Unlike other methods, this process generates enormous pressure during the operation of the electric current, and it is believed larger diamonds will crystallize out as the mixture cools. Mr. Hudson Maxim, the celebrated inventor, has also a new process by which it is believed large diamonds may be artificially made.

MR. PERCY EMARY is now the Secretary of the Geologists' Association, in the place of Mr. C. Davies Sherborn.

A PALAEOLOGICAL REVIEW.—The current number of "*Rivista Italiana di Paleontologia*" contains a list of the British and foreign palaeontological publications that were issued during 1896 and 1897, a series of reviews of the Papers, published during 1897, that bear on Italian palaeontology, and several interesting Papers by Professor G. Capellini, of Bologna, and others.

THE RATE OF FLOW OF THE LAVA STREAMS OF ETNA.—Ricupero observes that the lavas of Etna do not always run with the same rapidity, but are regulated in their course by the nature of the declivity over which they flow, and by the more or less subtle or tenacious quality of the lava itself. It is not, therefore, surprising that some streams should run many miles in a few days, such as that in 1408, which in twelve days advanced nearly ten miles, whereas others in whole years made but little progress: for example, that of 1614, which took the direction of Randazzo, but in the ten years for which it continued running, extended to no greater length than two miles. Sometimes the same torrent differs incredibly in its velocity: thus, Tedeschi says that in the eruption of 1669 the lava, at intervals, ran a mile in the space of four hours; at others, in four days it only advanced a few paces. In the year 1775, when two streams burst at once from the same crater, and having run twenty-four hours in succession, that which took a southern direction had made a progress of two hundred paces, while the other, in the same period, had reached a distance of eight miles.

GROWTH OF THE GLACIERS OF THE ALPS.—The glaciers of the Alps, according to Herr von E. Richter, are showing marked indications of increase in size, after having been diminishing quite rapidly for thirty years, with the exception of a transitory extension in 1875. From the historical records of about three centuries, it appears that the glaciers have had alternate periods of growth and diminution. In this time no less than eight marked epochs of growth can be traced, the first having begun in 1592, and the last—excluding the slight one in 1875—in 1835, each having been followed by a period of glacier retreat. The intervals between the epochs vary from twenty to forty-seven years.

The above paragraphs on geological subjects have been kindly sent to us by Mr. J. H. Cooke, F.L.S., of Lincoln.—ED. S.-G.]

By the kindness of Lady Prestwich and the trustees of the British Museum, an interesting and instructive series of fossils, consisting of the whole scale of fossiliferous rocks, and containing 833 specimens, has been presented to the Falconer Museum at Forres. This valuable collection has been systematically arranged by Mr. Bullen Newton, of the British Museum.

THE Geological Survey of Canada has recently acquired through the instrumentality of its director, Dr. G. M. Dawson, a mass of meteoric iron, which it is proposed to call the Thurlow Meteorite. It was found in 1888, in Ontario. It is described by Dr. Hoffman as an irregularly shaped truncated pyramidal mass, with a more or less rectangular base, measuring 16 by 13 1/2, or, including an elongated projection, 17 centimetres in its diameters, and 10 centimetres in height. Its weight is 5.42 kilos.

THE GLACIER GARDEN.—Many, besides geologists, have heard of the Glacier Garden at Lucerne, with its series of "pot-holes," in which still remain in many cases the huge boulders that gave rise to these rounded excavations. There is now to be seen in the same garden a large boulder of which a section has been made, and this reveals a nucleus round which the boulder has segregated, in the shape of a palm-leaf a foot in length. Probably the boulder was of a closer and more indurated texture than the substance which it afterwards excavated.

POT-HOLES.—The numerous Wadys up the Nile Valley appear to Professor Bonney to be only inexplicable on the supposition of a much heavier rainfall at one time than at present in those regions. This is also borne out by the numerous rounded stones which are there found, as well as the frequent and deep "pot-holes" in the ravines which intersect the crystalline hills, and which now serve as important water reservoirs. The excavation of these holes by means of a former increased water action is demonstrated by the fact that in the reservoir at Medina, in Jebel Raft, the spherical stones still occur, which assisted in forming the pot-hole.

EGYPTIAN GEOLOGY.—At the present time the geology of the Nubian Desert has a special interest in view of the movements of British troops in Upper Egypt. The geology of that portion south-east of Korosko has recently been receiving attention at the hands of Captain H. G. Lyons, R.E., F.G.S. The rocks consist mainly of Nubian sandstone, and crystalline rocks, both massive and schistose. These Archaean crystalline rocks are also found about Assuan, peering up through the nearly horizontal beds of Nubian sandstone, probably along the axes of low saddles. It was noticed that the sandstone was apparently divided into two series, the conglomerates and varied strata of the lower part, and the more solid sandstones of the upper, from which the building-stones of the great temples had been derived. At Wadi dur Nabadi were found some ancient gold workings.

VILLAGE BUILT ON A BOULDER.—The village of Great Catworth, in Huntingdonshire, enjoys the extraordinary distinction of being built upon a chalk boulder. This is not because the village is a very small one, but because the boulder is a very large one. Probably but few of its inhabitants know that the chalk upon which their cottages are built is not native to the spot. As a matter of fact, the chalk soil is but the surface of a huge boulder which has been carried from a point some twenty-five miles to the east to its present position, for there is no natural outcrop of the chalk at any nearer point. This great mass of removed chalk must have been carried by some giant iceberg, during the great ice age, from its native spot, and, as the ice melted, it must have dropped to the bottom of the glacial sea, there to be partially covered and surrounded on all sides by the well-known blue-grey boulder clay. This lump of chalk contains long layers of flints, and supplies the wells of the village with water, whereas water is very difficult to get in the surrounding clay. Chalk boulders of smaller size but many tons in weight are found scattered in the clay around, but none attain the dimensions of this tremendous half mile long erratic boulder.



CONTRIBUTED BY FLORA WINSTONE.

COSMOS (Paris, October 2nd). M. C. Marsillon writes "On the Country of the Troglodytes," giving two illustrations, one of the wonderful caverns formerly inhabited by a now almost forgotten race. They are chiefly occupied by the Tarahaumaris. M. A. Berthier contributes an article on various new contrivances for the better cultivation of bees. There are seven figures illustrating the several methods described in the letterpress. There are two short notes, by Professor Fr. Victor and M. C. Laugier, on the "Lighting Power of the Gas Products of Carbide of Calcium." M. W. de Fonvielle has two articles on earthquakes in the number of October 9th, one, "The Earthquake in India of the 12th June, 1897," and the other, the same earthquake as observed in Europe. The first of these communications is founded on some notes made by Mr. Oldham, Director of the Geological Survey in India. After careful study and consideration of these phenomena, Mr. Oldham thinks that the entire mass of the Himalayan range is slowly rising. The second article is an account of the chief features of the earthquake as felt and observed at Rocca di Papa (near Naples), at the University of Padua, and at the Observatory at Edinburgh. There is a diagram illustrating the course of the oscillations. This number contains also an interesting unsigned article on "The X Rays in 1708." These were apparently known to Dr. Hauksbee at that time, as he made use of rays the description of which bear a very close resemblance to those claimed to have been discovered by Professor Röntgen. M. C. de Kirwan commences a series of articles on the question of the Deluge. In this number he treats of the question from the universal geographical and ethnical side.

REVUE SCIENTIFIQUE (Paris, October 9th). M. Arthur Arrivet gives a long illustrated account of the work done by Percival Lowell in the investigation of the planet Mars. M. Louis Theureau commences a series of articles on the "Money in the Days of the Greeks." He gives an exhaustive account of the money in general use and of the probable value compared with modern currency. He also details the probable cost of an ordinary Greek household, consisting of four persons, in the days of Pericles.

LA NATURE (Paris, September 11th.) Dr. E. L. Trouessart writes on "The Acarien of the Sweet Wines of the South." The species dealt with by Dr. Trouessart is *Acarus passularum*, which was made into a distinct genus by Robin in 1869, under the name of *Carpoglyphus passularum*. M. H. Beauregard writes on "The Bacteriology of Amber." (September 18th.) M. Felix Regnault contributes an article on the various methods of "Walking and Running" of ancient and modern times. He compares the characteristic styles of the Greeks and Romans, giving illustrations from various statues. The issue dated September 25th contains

an article, by M. J. Carcelle, on "The Flowers of the Alps." M. Carcelle complains of the wholesale and wanton destruction of the rare and beautiful flowers that grow only on high altitudes. In 1883 an association was started at Geneva, having for its object the stopping of the destruction of "plants searched for on account of their rarity and which have become articles of commerce." This association has started gardens in places where the plants are most menaced, on purpose to preserve the existence of these Alpine species. M. J. Leffargue writes an illustrated article on the "Electric Cabs of London." M. J. Durand describes, with an illustration, "A Lizard with two Tails." The specimen is a green lizard, captured by M. Gervais, of Gigeau, and was found in the neighbourhood of the Herault. M. Jacques Boyer describes a new compound called "Irichromatine," which is "a new method of colouring substances without employing colours." (October 2nd.) M. J. F. Gall contributes a note on "Acaricus in Wine." It is an addition to the article on this subject by M. Trouessart in "La Nature," September 11th. M. Trouessart found only one species in sweet wines, viz., *Carpoglyphus passularum*. M. Mathiew, with the assistance of Professor A. Giard, found two species, *Glyciphagus cursor* and *Troglyphus farinae*. Colonel Laussedat describes a new instrument, named "Magnetarium," which has been presented to the French Academy of Sciences by M. Wilde. It is intended to reproduce the magnetic phenomena of the earth. M. Albert Tissandier has another article on various "Rocks of Peculiar Form." The number of October 9th contains an interesting article by M. Henri de Parville, on "The Memory of Fishes." The writer maintains that there is no reason why fishes should not have memories, as they possess the necessary construction of the cerebral system. He quotes some experiments and observations made by M. Ch. Guillaume with regard to the memory of fishes, showing that, though in a faint degree, they certainly possess that faculty. M. J. Derome describes "A Mirage" seen on September 3rd last, at Montgeron (Seine-et-Oise), a curious phenomenon in these temperate regions. M. M. Lebon writes on "Mercury Pumps," for the laboratory, describing a new pump given by M. Henriot to the Academy of Sciences.

AMERICAN JOURNAL OF SCIENCE (New Haven, Connecticut, October). Dr. Arnold E. Ortman writes "On a New Species of the Palinurid—Genus *Sinuparus*—found in the Upper Cretaceous of Dakota." This species, the writer says, is congeneric with a species living now in the Japanese seas, viz., *Palinurus trigonus*, the name of which stands at present, *Sinuparus trigonus*. The Geological Museum of Princeton University has lately acquired two unique specimens of a hitherto unknown fossil species entitled *Sinuparus atavus*. They were collected by Mr. H. F. Wells in the Niobrara group (Upper Cretaceous), at the head of Cotton-Wood Creek, Mead Co., South Dakota. They are the first remains of this group of Decapoda found on the American continent. Illustrations of the three species are given. Mr. Thomas Holm contributes some "Studies in the Cyperaceae." This article is one of a series, and deals chiefly with *Dichromena leucocephala* and *D. latifolia*. There are four figures to illustrate various sections. There is an account of "An improved Heliostat invented by Alfred M. Mayer," contributed by A. Goldsborough Mayer.



Reference: THE REV. E. ADRIAN WOODRUFFE-PEACOCK, L.T.H.,  
F.L.S., F.G.S., CADNEY, BRIGG.

ALBANISM.—In reply to Mr. A. H. Swinton, Clovernooke, Redbridge, Southampton, who has written to SCIENCE-GOSSIP questioning the fact of albanism being a diseased condition, I may say that the state of the chlorophyll which produces albanism in plants is considered an abnormal or diseased state, because species so affected have no chance in the struggle for existence with typically coloured species. After collecting notes on albanism in leaf and petal for years for the whole of the county of Lincoln, to say nothing of a huge collection of dry specimens, I can find out no natural law that rules in the matter. It seems to be produced by an hereditary weakness in certain forms of species. That it is hereditary can easily be proved from typical cases; for example, Dr. P. Blair, F.R.S., in 1723, recorded the fact that *Epilobium hirsutum*, L., *fl. albo*, grew within ten miles of Boston, Lincolnshire, towards Bolingbroke. He added, "I shall not doubt of its continuance with a white flower. They are always thereafter to be esteemed real species, since by proper experience, I find they never degenerate nor vary, as the finest flowers in gardens do, for which I think these field white flowers ought to be more esteemed than the other." (*Pharmaco Botanologia*, p. 25.) As I have given my copy of this rare work to the botanical library, Natural History Museum, South Kensington, I quote from my notes, which I believe are correct. This species, to my knowledge, was never recorded with white flowers before or since, so search was made, and Mr. J. T. Burgess, of Spilsby, "found a large patch of the *fl. albo* form on the left hand on the roadside just as you leave the village of West Heal for Hognaby." Here is a white-flowered variety constant for 174 years, but what does it prove? With thousands of notes, I can only say hereditary weakness, abnormality, or commonly, in one word, disease. If Mr. A. H. Swinton collects as many notes as I have done on abnormalities, colour forms and hybrids, he will be satisfied that in the present state of our knowledge the reason for these things is inscrutable. When we have quite mastered the laws of normal forms the day of the abnormal will dawn. Autumnal colouration and albanism are quite distinct matters and can only be confounded by careless thinkers; and that albanism is popularly disease can be easily proved from our forest trees. Who ever saw an albino ash much larger than a bush? Try to find a wood-merchant who wants variegated foliage timber at the ordinary price per foot. No good argument can be drawn from garden forms showing vigour and health, domestic animals, or man himself; they are the result of artificial selection as well as abnormal surroundings. They can of course illustrate the subject, but that is all—they prove nothing. Dr. Blair, writing in 1723, evidently knew that much. E. A. Woodruffe-  
P. 11



SOUTH LONDON ENTOMOLOGICAL AND NATURAL HISTORY SOCIETY.—September 23rd, 1897. Mr. R. Adkin, F.E.S., President, in the chair. Dr. Chapman, F.E.S., Elmscroft, Redhill (late of Hereford), was elected a member. Mr. Malcolm Burr presented to the Society's museum an almost complete collection of British Orthoptera. It is a most useful gift, and should encourage their study by the younger members. Mr. Auld exhibited series of *Tapinostola bondii* from Folkestone; of *Caradrina ambigua* from Devon, where it has been somewhat common this year; of *Dianthaecia nana* from Shetland; and of *Taeniocompa gothica* also from Shetland. Mr. Adkin, a bred series of *D. nana* from Shetland larvae, showing much variation. On behalf of Mr. de V. Kane, a specimen of *Laventia flavicinctata* taken in Antrim, which appears to be a new locality. Mr. Tutt, on behalf of Mr. Dutton, a very fine and variable series of *Abraxas sylvata (ulmata)*. A proportion of the specimens were smoky or partially smoky. These seemed somewhat thinly scaled, and as they were slightly crumpled and difficult to set, Mr. Dutton had suggested that the aberrations were due to malnutrition. Mr. Tutt also showed three species of *Ascalaphus* which he had captured in the Southern Alps, together with two species of ant lion. Mr. Burr, a specimen of *Phyllocrania illudens*, a mantis from Madagascar, with the leaves with which it is found. It is an extraordinary example of adaptation to surroundings, being very difficult to find even when attention is called to it in a small box. Mr. Turner, specimens of the hawk-fly, *Asilus crabroniformis*, from Seaton, Devon, and a series of the hemipteron *Enoplops scapha* taken over a very restricted area in the same locality on the leaves of coltsfoot. Mr. Perks a nest of the longtailed tit. A long discussion took place on the recently ascertained facts on the migrations of birds, especially as to a double migration of certain species which takes place in these islands. A paper was read, entitled "The British Day Butterflies and the Changes in the Wings of Butterflies," communicated by Professor A. Radcliffe Grote, A.M., in which he at some length explained his views as to the evolution of the venation, illustrated his remarks by and applied his theory to the British butterflies. He severely criticised the work of Mr. Meyrick, and more fully explained himself to his own critics.—October 14th, 1897, Mr. R. Adkin, F.E.S., President, in the chair. Mr. Mansbridge exhibited varieties of *Abraxas grossulariata*, bred this season from Horsforth larvae. The aberrant forms were not so numerous this year, but the line of variation was similar to that observed in former years, viz., a gradual suffusion of the fore-wings with the black colour. Mr. South, small specimens of *Pieris rapae* taken at Folkestone by Mr. Sabine, having an additional spot on the hind wings. He noticed the same peculiarity in some specimens of *P. napi*, and said that the same variation occurred in the allied Chinese Pierids. Two specimens of *Callimorpha dominula* var. *rossina* from



Dover, and a bred series of *Acidalia inornata* were also exhibited by Mr. South. Mr. H. Montgomery, on behalf of E. Montgomery, a series of bred *P. napi* including specimens with traces of an additional spot, and read notes on the variation shown in the series. He also exhibited a uniformly xanthic specimen of *Epinephele tithonus*, and a specimen of *Abraxas grossulariata* having an additional complete band on the hind wings. Mr. McArthur, a specimen of *Arctia caja* with perforated wings, which had been caused by the larva changing on the sandy bottom of the cage, a piece of grit piercing the wing case. There was also an indentation in the hind margin, perfectly ciliated, which had no doubt been caused by a similar obstruction. Mr. Cockerell communicated a note upon a peculiar case of protective colouration observed by him in Mexico. In a clump of orange composite flowers he saw a *Vanessid* pupa and a larva of a *Sphinx* about to change its skin. Mr. Ficklin, a series of *Polia flavicincta* from Cornwall, small, but brightly marked.—*Hy. J. Turner, Hon. Report. Sec.*

NORTH LONDON NATURAL HISTORY SOCIETY.—September 16th, Mr. C. Nicholson, F.E.S., President, in the chair. Exhibits: Mr. Oldham, among numerous other species, *Nevria saponariae* from Lincolnshire, and a var. of *Noctua xanthographa* from Woodford, all taken this year. Miss Martin, *Marchantia polymorpha* in fruit. Mr. Simes remarked on the present abundance in Epping Forest of squirrels, jays and marsh-tits. He had seen ten squirrels that day between Chingford and Theydon. Mr. Culpin made some remarks relative to the habits of a large Australian cicada, a specimen of which he exhibited. The larvae of this interesting insect lived underground, and the pupae walked some distance up a tree trunk just before emergence. Mr. Jennings read an "Explanatory Paper on the Order Hymenoptera," in which he described in detail the classification of that group of insects and the habits of many of the more interesting families. After giving the distinguishing characters by which the Hymenoptera are separated from other orders, he said they were primarily divided into two groups, Terebrantia and Aculeata, the former comprising those characters in which the ovipositor is chiefly used as a saw or borer, and the latter those in which it is modified into a sting. He then worked through the families in detail, and described the economy and structural peculiarities of each. In the Ichneumonidae he referred to the interesting question whether it is possible for a lepidopteron to recover from the attack of an ichneumon, and cited the case of the larva of *Acherontia atropos*, bred by the Rev. A. P. Morres, of Salisbury, which had pupated in the ordinary way and emerged as a perfect moth, but in the body of which, on its being opened for the purpose of preservation, a large ichneumon maggot had been found. He stated that it was the opinion of the Rev. T. A. Marshall (who had written a short paper on the above case in the "Entomological Monthly Magazine," for December, 1896) that if left to nature this particular moth would ultimately have recovered. The paper was accompanied by a small collection illustrative of the more typical families in each of the two primary divisions. Messrs. Culpin, Harvey, L. J. Tremayne, Prout, Bacot, and C. B. Smith took part in an interesting discussion which followed.

CITY OF LONDON ENTOMOLOGICAL AND NATURAL HISTORY SOCIETY.—September 7th, 1897. Mr. J. W. Tutt, F.E.S., President, in the chair. Exhibits:

Mr. Tutt, rare aberrations of *Abraxas ulmata*, from Mr. Dutton, of York; also, on behalf of Mr. Tuck, nests of *Bombus lapidarius*, taken on August 13th at Tostock, near Bury St. Edmunds; these were all attacked by *Aphomia sociella (colonnella)*; representatives of the two bombi and the vespa, whose nests were exhibited; also an aberration of *Melanippe fluctuata* without markings, except a very small basal patch and the central discoidal spot. This was taken three or four days before at Boxhill. Mr. Oldham, pink variety *Scabiosa succisa* from Epping Forest, and varieties of lepidoptera. Mr. Garland, a light specimen of *Sphinx ligustri*, bred, four *Smerinthus tiliæ*, one type and three others showing the band-like mark much reduced, bred from South Tottenham pupae this season; aberrations of male and female *Angerona prunaria*, bred from larvae from Chepstow, Monmouthshire. Mr. Sauzé, specimens of *Myrmeleon formicarius* and *Tipula gigantea* collected by Mr. Tutt at Suza.

CAMBRIDGE ENTOMOLOGICAL AND NATURAL HISTORY SOCIETY.—At the meeting of October 15th, Mr. Rickard exhibited a specimen of *Choerocampa celerio* taken recently in Cambridgeshire and an imago of *Carpocapsa saltitum*, reared from the so-called "jumping bean"; he also exhibited some small ichneumons, bred from a probably detoid larva. He said that they were peculiar in that they did not kill their host, and he believes that they inhabit the alimentary canal of the caterpillar and escape by the ventral orifice. He has seen the caterpillar carrying the cocoon made by one of these larvae, holding it with the anal claspers for some days. Mr. Farren exhibited a variety of *Dianthoecia conspersa* from Shetland, *C. corylata* var. *albo-crenata* from Rannock, and *Taeniocampa gothica* var. *gothacina* from Loch Laggan. Dr. Sharp exhibited several South American cocoons of two species, one bombycoid, the other psychid. One of the former contained a large ichneumon cocoon, in which again were smaller ones of another species, while two others had been used by a mason-wasp and a leaf-cutting bee respectively to make their nests in. The psychid cocoons were tubular, about four inches long and half-an-inch thick, the females being largest, and it appeared that the female moths never leave the cocoon, for one of them was found hardly free from the large chrysalis, embedded in soft scales, and almost maggot-like in appearance. Although the larva spend a large part of their lives in these cocoons, yet a large proportion were found to have been killed by parasites. Mr. Bedford exhibited three varieties of *Epinephele hyperanthus*, taken near Brockenhurst at the end of June; in the first, a female belonging to the "lanceolate" type, all the parts of each ocellus were correspondingly enlarged, the central pupil in some being considerably elongated; in the second, a male, the aberration affected the fore-wings only, and consisted in a tendency for the yellow band of each ocellus to spread over the surface of the wing, forming irregular and quite asymmetrical blotches, the rest of the ocellus being quite normal; the third case was that of a male in which the right hind wing only was abnormal, both the black and yellow bands of all the ocelli, except that nearest to the anal angle, being so much enlarged as to run into one another, forming a black streak surrounded by yellow, covering the greater part of the wing and traversed by the wing rays, which were dusted over with yellow scales; the pupils of three of the ocelli were quite normal, that of the fourth (next to the costal margin) was barely visible.



**HULL SCIENTIFIC AND FIELD NATURALISTS' CLUB.**—The annual meeting of this Club was held on September 29th. Dr. J. Hollingworth, the President, occupied the chair. The Secretaries' report showed that the progress during the year was in a very satisfactory condition, including thirty-eight new members elected and an increase of fifty per cent. in attendance at meetings and excursions. There is a satisfactory cash balance in hand. Several additions had been made to the Club's collection. The reports for geology, botany, conchology, entomology and ornithology were given by Messrs. Sheppard, Robinson, Fierke, Boulton and Audas respectively, which showed that good work had been done by the various sections. The botanists have been working out the flora of the East Riding, and have added the following to the Club's list of East Riding plants, in addition to which several new localities have been discovered for previous records: *Cerastium tetrandrum*, *Polygonum bistorta*, *Allium scorodoprasum*, *Carydium frutescens* var. *deriata*, *Rubus althoeifolius*, *Salix triandra*, *Teraxacum officinale* var. *palustre*, *Polystichum aculeatum* and *Calamagrostis lanceolata*. The entomologists regretted that the past year had been a very poor one so far as collecting was concerned, the cold nights and abundance of "honeydew" making the "sugaring" process a total failure. Notwithstanding this, however, three new records have been made for the district. The lectures were arranged for the winter session. The officers for the coming year were then elected as follows: President, Dr. J. Hollingworth; Vice-presidents, Messrs. J. F. Robinson, T. Audas, L.D.S., and J. R. Boyle, F.S.A.; Treasurer, Mr. F. W. Fierke; Curator, J. W. Boulton; Librarian, Mr. J. Porter; Recorders (archaeology), Mr. J. R. Boyle, (microscopy) Dr. Hollingworth and Mr. Robinson, (marine biology) Mr. Fierke, (Mammalia and Aves) Mr. Audas, (Pisces) Mr. H. M. Foster, (Mollusca) Mr. Fierke, (Arachnida) Mr. G. Ross, (Lepidoptera) Mr. J. W. Boulton, (Coleoptera) Mr. Russell, (botany) Mr. J. F. Robinson (general) and Mr. H. Philip (Diatomaceae), (geology) Mr. Sheppard; Committee, Messrs. H. Knight, J. L. Stratford, T. Thelwall, C. Waterfall, A. H. White and Rev. C. A. Hall; Secretary, T. Sheppard, 78, Sherburn Street, Hull. The first meeting for the winter session was held in the club's room, Prospect Street, on October 13th, Mr. J. R. Boyle, F.S.A., occupied the chair. There was a large attendance of members. Mr. R. H. Philip exhibited under the microscope some very fine foraminifera which he had extracted from the Hesse Chalk after very careful washing. Mr. Audas brought a large vertebra of a Saurian which had been dug from a depth of twenty feet at Easingham. Six gentlemen were elected members of the Society. Mr. J. F. Robinson then read a paper on the "Flora of the East Riding." Remarkable though it may seem, almost every county or district throughout the kingdom has had an account of its flora published, with the exception of the East Riding of Yorkshire. Robert Teesdale's list of Yorkshire plants, which was published precisely 100 years ago; Scam's "Beverlac" of later date, and other works refer briefly to the flowers of this Riding, but so far not a single account has been written dealing exclusively with the flora of this area. After twelve years of investigation, Mr. Robinson has given the first flora of the East Riding. The lecturer carefully summarized the work of previous observers, and referred to the various documents which contain references to this district, all of which only have brief accounts

of this or that group of plants. Robert Teesdale's list is certainly the most complete and reliable, and Mr. Robinson alluded to the delight and enthusiasm our members had evinced when finding a plant in confirmation of a list published a century ago. The lecturer proposed to split up the district under consideration into three geological divisions, viz., (1) Holderness proper, composed almost exclusively of glacial clays and gravels; (2) the Wolds—the chalky area; and (3) the Vale of York, west of the Wolds—chiefly sandy flats. The lecturer then further subdivided these areas, and dealt with the coast plants, the estuarine and aquatic, describing each in order. Finally Mr. Robinson submitted his list of plants, consisting of between 800 and 1,000 species. A large number of actual specimens of the more important kinds were exhibited round the walls of the room, and the Paper was further illustrated by an excellent cross-country section, on a large scale, showing the geological features of the Riding, which had been prepared specially for the lecture by Mr. W. H. Crofts. Mr. Robinson's Paper will duly appear in the Club's Proceedings.—T. Sheppard, Hon. Sec., 78, Sherburn Street, Hull.

## NOTICES TO CORRESPONDENTS.

**TO CORRESPONDENTS AND EXCHANGERS.**—SCIENCE-GOSSIP is published on the 25th of each month. All notes or other communications should reach us not later than the 18th of the month for insertion in the following number. No communications can be inserted or noticed without full name and address of writer. Notices of changes of address admitted free.

**NOTICE.**—Contributors are requested to strictly observe the following rules. All contributions must be clearly written on one side of the paper only. Words intended to be printed in *italics* should be marked under with a single line. Generic names must be given in full, excepting where used immediately before. Capitals may only be used for generic, and not specific names. Scientific names and names of places to be written in round hand.

The Editor is not responsible for unused MSS., neither can he undertake to return them, unless accompanied with stamps for return postage.

**SUBSCRIPTIONS.**—Subscriptions to SCIENCE-GOSSIP, at the rate of 6s. 6d. for twelve months (including postage), should be remitted to the Proprietors, 85, St. Martin's Lane, London, W.C.

ALL editorial communications, books or instruments for review, specimens for identification, etc., to be addressed to JOHN T. CARRINGTON, 1, Northumberland Avenue, London, W.C.

## EXCHANGES.

**NOTICE.**—Exchanges extending to thirty words (including name and address) admitted free, but additional words must be prepaid at the rate of threepence for every seven words or less.

**WANTED,** mounted slides or specimens of the Myxomycetes, (Mycetozoa).—W. H. Pepworth, The Avenue, Alderley Edge, Cheshire.

**WANTED,** well set Lepidoptera or living ova or pupae. Offered, good microscopical slides in exchange.—J. Collins, 201, Green Lane, Birmingham.

**SHELLS.**—Offered, large collection, including *Helix latiaxis*, *Linteria*, *Tayloriana*, *quaesita*, *vernus*, *lubiana*, and vars. *Magilus antiquus*, *Volva pacifica*, *Rostellaria fusus*, *Pteroceros multipes*. Wanted, exotic *Helices*.—Miss Linter, Attraction Close, Twickenham.

**WANTED,** Fowler's "British Coleoptera," Newman's "Butterflies and Moths," or Bentham's "Botany."—Charles Moley, Museum Press, Huddersfield.

**WHAT** offers in microscopic slides for the first 15 numbers of SCIENCE-GOSSIP, new series. H. Platt, Priory Villa, Victoria Road N., Southsea.

**CARPET** moths and butterflies, (foreign and British), high-class collection; useful exchange wanted.—B. Turnbull, 46, Grindlay Street, Edinburgh.

**EGGS IN CLUTCHES.** Gullinot, razorbill, cormorant, chag, oyster catcher, kestrel, sparrow hawk, magpie, jay, wedge warbler, lesser redpoll, bullfinch, hooded-crow, woodcock, nightjar, long-tailed tit, chough. Wanted, other eggs in clutches.—Rev. W. W. Fleming, Coolin, Portlaoigh, Ireland.

## CORRESPONDENCE.

W. B. (Colchester).—We cannot recommend any especial means of getting rid of hornets which nest in an inaccessible place. Perhaps repeated spilling of paraffin about the entrance to the nest might drive them away. This sometimes succeeds with wasps.

## NOTICES OF SOCIETIES.

## GEOLOGIST'S ASSOCIATION OF LONDON.

Nov. 5.—Conversazione and Exhibition in Library of University College, Gower Street, 8 p.m. (morning dress).

## THE SOUTH LONDON ENTOMOLOGICAL AND NATURAL HISTORY SOCIETY.

Nov. 11.—"The drinking habits of butterflies and moths." Mr. Tutt, F.E.S.  
 " 25.—"Lantern pictures of birds and their nests." Mr. Harrison, F.C.S.

## NORTH LONDON NATURAL HISTORY SOCIETY.

Nov. 4.—"Through Cornwall and Devon." J. A. Simes.  
 " 18.—Debate: "Does scientific study destroy or militate against the aesthetic tastes or sense?" Opened in the affirmative by F. W. Frost; opened in the negative by A. Bacot.  
 Dec. 2.—"Insectivorous Plants." R. W. Robbins.  
 " 16.—General Business Meeting—Election of Officers for 1898.

## LAMBETH FIELD CLUB AND SCIENTIFIC SOCIETY.

Nov. 1.—"Prehistoric Man." G. F. Lawrence.  
 " 8.—"Annual Soiree, 7.30. (See "Notes and Queries.")  
 " 15.—"Photo micrographs of Insect Anatomy," with lantern illustrations. F. Clark.  
 " 20.—"Visit to British Museum, Prehistoric Section  
 Dec. 6.—"Fossils, and the ways in which they are found preserved." Dr. H. F. Parsons.  
 " 11.—"Visit to Natural History Museum, Shell Gallery.  
 " 13.—"Photographic Demonstration. C. J. Stokes.

## CONCHOLOGICAL SOCIETY, LONDON BRANCH.

Nov. 11.—Meeting at 7.30 p.m., at St. Peter's Rectory, Walworth. Rev. J. W. Horsley will introduce *Helix aspersa* and its varieties. Members and other conchologists invited to bring specimens, as also other shells, for exchange.—J. E. Cooper, Hon. Sec., 93, Southwood Lane, Highgate, N.

## LUBBOCK FIELD CLUB.

Nov. 14.—Theobald's Park, Cheshunt and Wormley.  
 Dec. 12.—Totteridge, Shenley and Ridge.

## NORTH KENT NATURAL HISTORY AND SCIENTIFIC SOCIETY.

Nov. 3.—Annual Meeting. "Geology and Minerals." Mr. Mintern.  
 " 17.—"Setting and Mounting Coleoptera." G. H. Cornish.  
 Dec. 1.—"Origin and Physical Description of the Earth and Moon." W. Turner.  
 " 15.—"Mounting Slides." Wm. Scott.  
 " 29.—"The Microscope." Jno. Stacey.  
 1898.  
 Jan. 12.—"Bacteria." C. J. Brooks.  
 " 26.—"Entomology." H. Broughton.  
 Feb. 9.—"Leaves: their Structure and Use." J. W. Cooper.  
 " 23.—"Aquaria and Uncommon Pets." Jno. Potter.  
 Mar. 9.—"Conchology." E. Dennis.  
 " 23.—"British Birds' Eggs and Nests." D. Miller.  
 April 6.—"Lepidoptera." S. J. B. Pine.

## HULL SCIENTIFIC AND FIELD NATURALISTS' CLUB.

Nov. 10 } Exhibition and Conversazione.  
 " 11 }  
 " 24.—"Photo-Micrography," lantern illustrations. Dr. J. Hollingworth.  
 Dec. 8.—"Davos, the Engadine and the Italian Lakes." R. H. Philip.  
 Jan. 5.—"The Fishes of the River Hull." H. M. Foster.  
 " 19.—"The formation of an English Village," lantern illustrations. J. R. Boyle, F.S.A.  
 Feb. 2.—"Breeding-Haunts of British Birds," lantern views. T. Audas, L.D.S.  
 " 16.—"An Early Doctrine of Evolution." Rev. C. A. Hall.  
 Mar. 2.—"The Natural History of Goole Moor," Thos. Bunker.  
 " 16.—"Spectroscopic Astronomy," lantern illustrations. Rev. H. P. Slade, M.B.A.A.  
 " 30.—"The Marine Fauna of the Yorkshire Coast," lantern views. F. W. Fierke, M.C.S.  
 The Meetings held at 72, Prospect Street, alternate Wednesdays, 8 p.m.—T. Sheppard, Hon. Sec., 78, Sherburn Street, Hull.

## METROPOLITAN SCIENTIFIC SOCIETIES.

The following is a list of societies in the London district devoted to natural science, with hours and places of meeting. They may be visited with introduction from a Fellow, Member, or Secretary. Will secretaries send additions or corrections.

ANTHROPOLOGICAL INSTITUTE OF GREAT BRITAIN, 3, Hanover Square. Second and fourth Tuesdays at 8.30 p.m., November to June.

CITY OF LONDON COLLEGE SCIENCE SOCIETY, White Street, Moorfields, E.C. Last Wednesday in each month, October to May, 7.30 p.m.

CITY OF LONDON ENTOMOLOGICAL AND NATURAL HISTORY SOCIETY, London Institution, Finsbury Circus. First and third Tuesdays, 7.30 p.m.

CONCHOLOGICAL SOCIETY, LONDON BRANCH, St. Peter's Rectory, Walworth. Irregular meetings. Rev. J. W. Horsley, President, will answer enquiries.

CROYDON MICROSCOPICAL AND NATURAL HISTORY CLUB, Public Hall. Third Tuesdays, October to May, 8 p.m.

DULWICH SCIENTIFIC AND LITERARY ASSOCIATION. Fortnightly lectures Lordship Lane Hall, second and fourth Mondays, 8.15 p.m., from October, for winter season.

EALING NATURAL SCIENCE AND MICROSCOPICAL SOCIETY, Victoria Hall, Ealing. Second and last Saturdays, October to May, 8 p.m.

ENTOMOLOGICAL SOCIETY, 11, Chandos Street, Cavendish Square. First Wednesday, October to June (except January). Third Wednesday, January, February, March and November, 8 p.m.

GEOLOGISTS' ASSOCIATION, University College, Gower Street. First Friday, 8 p.m., November to July.

GEOLOGICAL SOCIETY OF LONDON, Burlington House, Piccadilly. First and third Wednesdays, 8 p.m., November to June.

LAMBETH FIELD CLUB AND SCIENTIFIC SOCIETY, St. Mary Newington Schools, Newington Butts, S.E. First Mondays all the year and third Mondays in winter, 8 p.m.

LINNEAN SOCIETY OF LONDON, Burlington House, Piccadilly. First and third Thursdays at 8 p.m., November to June.

LONDON AMATEUR SCIENTIFIC SOCIETY, Memorial Hall, Farringdon Street, E.C. Fourth Friday in each month, October to May, 7 p.m.

LUBBOCK FIELD CLUB. Working Men's College, Great Ormond Street, Bloomsbury, W.C. Excursions second Sundays, Meetings following Mondays, 8 p.m.

MALACOLOGICAL SOCIETY OF LONDON, meets in Linnean Society's Rooms, Burlington House. Second Friday each month, November to June, 8 p.m.

MINERALOGICAL SOCIETY. Meets in rooms of Geological Society, February 4th, April 14th, June 23rd, November 17th, 8 p.m.

NONPAREIL ENTOMOLOGICAL AND NATURAL HISTORY SOCIETY, 99, Mansfield Street, Kingsland Road, N.E. First and third Thursdays, 8 p.m.

NORTH KENT NATURAL HISTORY AND SCIENTIFIC SOCIETY, St. John's Schools, Wellington Street, Woolwich. Alternate Wednesdays, 7.30 p.m.

NORTH LONDON NATURAL HISTORY SOCIETY, North-East London Institution, Hackney Downs Station. Second and fourth Thursdays, 7.45 p.m.

QUEKETT MICROSCOPICAL CLUB, 20, Hanover Square. First and third Fridays, 8 p.m.

ROYAL BOTANIC SOCIETY OF LONDON, Regent's Park. Second and fourth Saturdays at 3.45 p.m.

ROYAL HORTICULTURAL SOCIETY, 117, Victoria Street, S.W. Second and fourth Tuesdays, except December to February; 2 p.m. on show days, which vary.

ROYAL METEOROLOGICAL SOCIETY, 22, Great George Street, Westminster. 3rd Wednesday, November to June, 8 p.m.

ROYAL MICROSCOPICAL SOCIETY, 20, Hanover Square. Third Wednesdays, October to June, 8 p.m.

SELBORNE SOCIETY, 20, Hanover Square. No winter meetings.

SIDCUP LITERARY AND SCIENTIFIC SOCIETY, Public Hall, Sidcup. First and third Tuesdays, October to May, 8 p.m.

SOUTH LONDON ENTOMOLOGICAL AND NATURAL HISTORY SOCIETY, Hibernia Chambers, London Bridge, S.E. Second and fourth Thursdays, 8 p.m.

SUTTON SCIENTIFIC AND LITERARY SOCIETY, Public Hall Chambers. Second and forth Tuesdays, 8 p.m.

WEST KENT NATURAL HISTORY, MICROSCOPICAL AND PHOTOGRAPHIC SOCIETY. Meets in School for Sons of Missionaries, Blackheath, third Wednesday, in December, fourth Wednesdays in October, November, January, February, March, April, May, 8 p.m.

ZOOLOGICAL SOCIETY OF LONDON, 3, Hanover Square. First and third Tuesdays, 8 p.m., November to August.

BRITISH FRESHWATER MITES.

By C. F. GEORGE, M.R.C.S.

I HAVE again the pleasure of increasing my list of Arrenuri by the addition of four more species, three of which I have taken in my own immediate neighbourhood: the other one was found by Mr. Soar at Sunningdale.

Fig. 1.—*Arrenurus buccinator* (male). This very beautiful little mite is well figured, though rather

be De Geer's *caudatus* (Heft. 2, fig. 24), which, however, is different apparently from my mite, not having the peculiar last joint but two of the hind legs, and being destitute of the very remarkable hairs on the tail, to be found in tailed mites generally. These, however, may have been accidentally rubbed off in the specimen from which Koch made

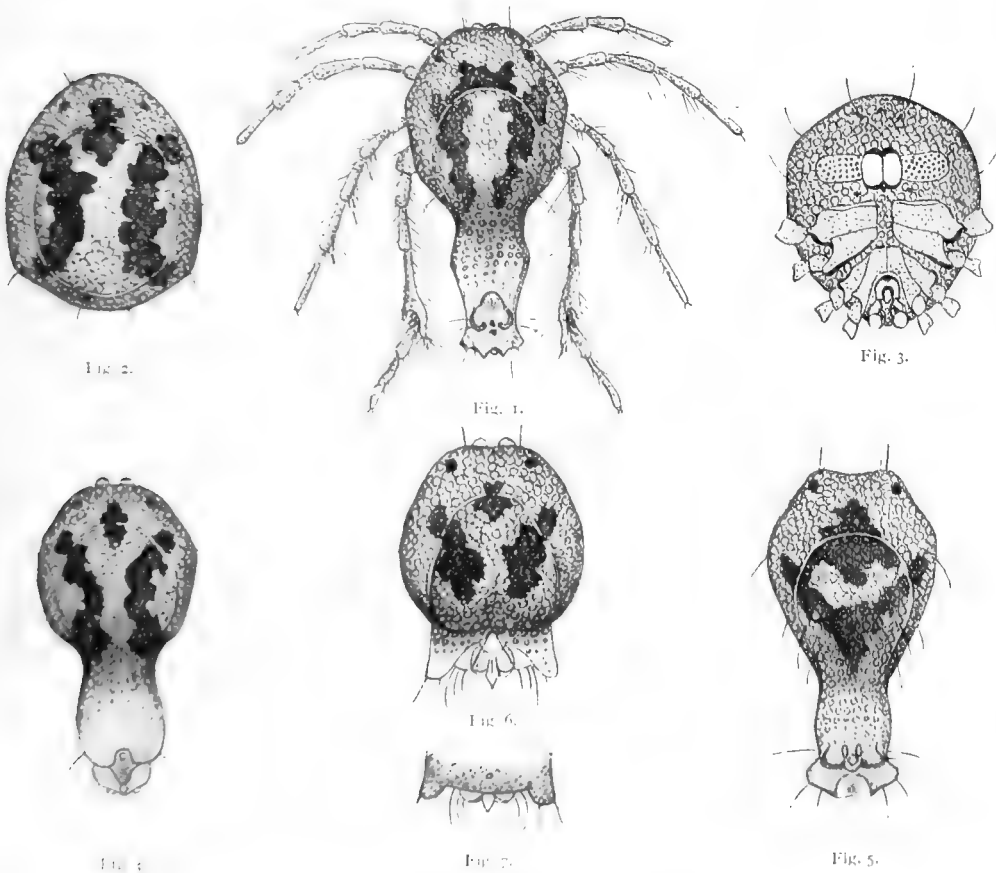

WATER MITES.

1. *Arrenurus buccinator*. Fig. 1, dorsal surface, *A. buccinator*, female; Fig. 3, ventral surface, *A. buccinator*, female; Fig. 4, *A. zachvatkini*, female; 5, *A. festivus*, Figs. 6 and 7, *Arrenurus* (? sp.) and its ventral surface.

highly coloured, by Koch, in his "Deutschlands Crustaceen," Heft 13, fig. 7, mas. He says it is *Mullers buccinator*. If this be correct, as I think it is, then the mite figured by me in SCIENCE-GOSSIP for December, 1882, p. 273, fig. 203, under the name of "*Arrenurus buccinator*," is a mistake, and must be some other *Arrenurus*, possibly the *caudatus* of De Geer, whose figure I have not yet seen. Koch figures a mite, which he considers to

his drawing. Doubtless, when Piersig's great work on "Water Mites," now in progress, reaches *Arrenurus*, all these difficulties will disappear; I fear, however, that it will be some time before that portion is published. The female (fig. 2, dorsal surface, and fig. 3, ventral surface) is in shape very much like many other female *Arrenuri*. Its identity is, however, very well made out, because it has been taken by myself, coupled

with the male, on more than one occasion. The process is well described by Mueller: it is very curious, and, as in the fleas, the female is uppermost, and is larger and more powerful than the male. Mr. Soar gives the length of the male in this species as 1.63 mm., and that of the female 1.086 mm.

Fig. 4.—The next mite is *Arrenurus zachariae*. I have not seen this mite alive, but have had the pleasure of examining it in preservative solution, which, however, unfortunately, discharges the colours. It was found by Mr. Soar at Sunningdale. The formation of the tail, as will be seen by the figure, is very different from the other tailed mites. It was named by Koenike, and is probably rather rare in England, one specimen only having been found. Its legs are much like those of *A. buccinator* and many other tailed mites. Mr. Soar gives its length as 1.04 mm.

Fig. 5 has been named *Arrenurus festivus* by Koenike. The tail will be seen to be more cylindrical, the sides straighter, and the termination more dilated than is found in the other mites here figured. Mr. Soar gives its length as 1.32 mm.

I found it in company with *A. buccinator*. I have not detected the female belonging to this mite. Fig. 6 represents a male *Arrenurus*, with a much shorter and broader tail than the others; I have not been able to make out its name. It was found by Mr. Soar, at Staines, last year, and I myself met with it on several occasions, so that it is by no means rare, and therefore has doubtless been described and named. It resembles somewhat *Arrenurus albator*, Mueller, but has the central part, or petiole, of the tail spear-shaped. In "Zoologischer Anzeiger," No. 401, for September, 1892, p. 342, is a figure of the tail of a mite something like this, with the exception of the petiole, which is there heart-shaped. I shall be very glad, if any reader of SCIENCE-GOSSIP has met with a description or figure of this mite, if he will kindly give me the reference to it. Fig. 7 represents the ventral surface of this doubtful *Arrenurus*.

I have again to express my thanks to Mr. Soar, for so kindly drawing for me the figures which accompany and form so important a part of these notes.

Kirton in Lindsey.

## EARWIGS.

By MALCOLM BURR, F.E.S., F.Z.S.

IN the whole history of Entomology, with some exceptions, few insects have received such scant attention as earwigs. On reading up the literature of the subject, it will be found that all descriptions and notes are contained in various papers scattered through the scientific journals, "Proceedings" of societies, in various languages, and in rare cases they are to be found in the pages of a larger work dealing with different groups and orders. Several species were described in the more important works by Linnæus, Fabricius, Serville, Burmeister, and De Haan. The first systematic paper was H. Dohrn's "Versuch einer Monographie der Dermapteren," in the "Stettiner Entomologische Zeitung," commencing in 1862. About that time, the Swedish entomologist, Stal, described several earwigs, and more than ten years later Scudder described (1) a number of species from the "New World." He also compiled a complete catalogue (2) of all the then known kinds, in his Critical and Historical notes upon the genera. Since 1876, that eminent American entomologist has published little work on this group. About the same date, De Bormans began to publish, and has since been the leading authority upon the subject, and his long-wanted monograph is expected to shortly appear.

Within recent years a few species have been

described by W. F. Kirby (1), Brunner (2), Karsch (3), Bolivar (4), and the writer (5). The known number of species is 378, not including five *incertae sedis*. They are distributed through thirty-one genera, but more will be added by the appearance of a systematic work upon earwigs.

The genera are separated upon details of structure, which will be made apparent in the following notes. There is a scutellum visible between the elytra at the base in seven genera, viz., *Apachya*, *Tagaiina*, *Neolobophora*, *Pygidicrana*, *Nannopygia*, *Cylindrogaster* and *Diplatys*. In the remaining genera there is no visible scutellum, except perhaps in some subapterous kinds.

In fifteen genera the small second tarsal segment is simple and cylindrical, viz., in *Pyragra*, *Brachylabis*, *Platylabia*, *Echinosoma*, *Echinopsalis*, *Labidurodes*, *Psalis*, *Labidura*, *Chaetospania*, *Sparatta*, *Mecomera*, *Anisolabis*, *Labia*, *Auchenomus* and *Spongophora*. These again are subdivided according to the presence or absence of little lateral tubercles on the second and third abdominal segments.

The remaining genera have the second tarsal segment more or less lobed or heart-shaped; in *Chelisoche* it is produced into a lobe under the third tarsal segment, but in all others is simply lobed.

(1) Linn. Soc. Journ. Zool., xxiii., 1891, xxv., 1896.

(2) Prodröm der Europäischen Orthopteren, Leipzig, 1882.

(3) Berl. Ent. Zeit., xxx., 1886; Ent. Nach., 1885, 32, 2.

(4) Act. Soc. N. H. Esp., xxii.

(5) Ann. Mag. N. Hist. (6), xx., 1897.

(1) Proc. Bost. Soc. Nat. Hist., xvii., 1875.

(2) "Entomological Notes," v., 1876, reprinted from Proc. Bost. Soc. Nat. Hist., xviii., 1876.

The forceps will probably make a useful character, as although they vary considerably in length in some cases, the actual form and arrangement of teeth is more or less constant. In *Spongophora croceifemnis*, Serv., the forceps vary from 4 mm. to 18 mm. in length, and the same phenomenon is observed in the common *Forficula auricularia*, L., as Messrs. Bateson and Brindley (1) have shown.

Of the uncertain species there is the insufficiently described *Condyopalama agilis*, Sund. (2), an active little insect taken some years ago at Stockholm, believed to have been imported from Brazil. *Typhlotabia larva* (3), Phil., is supposed to belong to the genus *Iafyx*, Thysanura. There are also two species of *Hemimerus*, Walk., *H. taipeioides* (4), Walk., and *H. hansenii* (5), Sharp. These extraordinary insects will probably form a separate family of the Forficularia (earwigs), as arranged by Dr. Sharp in the Cambridge Natural History. Walker erected his genus *Hemimerus* as a strange kind of mole cricket. The last uncertain species is *Dyscritina longisetosa* (6), Westw., which Mr. E. E. Green is now studying in Ceylon, among its native haunts. He has succeeded in rearing it to maturity, for only the nymph had been known hitherto. Mr. Green has discovered that it possesses fully developed organs of flight. Also he finds that by an extraordinary phenomenon, the jointed caudal setae, which gave rise to a discussion as to whether it was really an earwig, are converted into forceps. It may prove to be a relic of the ancestral form of earwig, and very likely the genus *Pygidicrana*, or perhaps *Cylindrogaster* or *Diplatys*, will be its nearest allies. It will possibly form a separate family, in which case Forficularia must be raised to the rank of a sub-order of Orthoptera, or else an order of its own, as now held by Brauer and others.

Earwigs do not seem to be numerous insects in the tropics, and little is known of their habits. De Bormans tells us that *Afachys*, *Chelisoche*, *Platylabia* and some species of *Labia* are to be found under bark, and *Brachylabis* and *Opisthocosmia* under dead leaves, or rubbish, or very ripe fruit. Some species are frequenters of the seashore and may be found among the shingle, or some under stones, especially in damp places. Certain European species inhabit high mountains, almost in the snow and by the edges of glaciers. Others are known to be able to give off defensive smell from the lateral tubercles, which are probably stink-glands. The forceps are the homologues of the cerci of other Orthoptera, and Mr. Gahan tells me that he has detected traces of segmentation in the

forceps of very young larvae. These sometimes assume very curious shapes, especially in the genera *Opisthocosmia* and *Anechura*. In some species of *Spongophora* and the spiny earwigs not yet separated from *Labidura*, the forceps are longer than the body.

Earwigs are remarkable for showing a distinct attachment for their ova. De Geer was the first to notice this habit, and his account is well known. Colonel Bingham once observed a large earwig in Burmah, which, when disturbed by the men looking for fuel for the fire, instead of seeking safety for herself, gave all her care to a batch of ova.

Ten species have been taken in Britain. Of these *Labidura riparia*, Pall., has been taken five or six times on the South Coast; *Anisolabis maritima*, Bon., was taken in numbers at South Shields, in 1856; *A. annulipes*, Luc., has been taken in several places, imported from abroad, being a cosmopolitan species, as, in fact, are the last two; the oriental *Chelisoche morio*, Fabr., has occurred at Kew Gardens; *Labia minor*, L., is fairly common, and *Forficula auricularia*, L., is abundant; *F. lesnei*, Finot, has been taken twice, at the Warren at Folkestone, and at Wallingford, in Berkshire; *F. pubescens*, Gènè, has been recorded several times, but probably it is a case of mistaken identity, *F. lesnei* having been the real insect; *Apterygida albipennis*, Meg., was captured by Westwood sixty years ago, but not since, and *A. arachidis*, Yers., has thoroughly established itself at Queenboro', on the Medway.

#### LIST OF GENERA OF FORFICULARIA.

- Afachya*, Serv., seven species.
- Tagaluna*, Dohrn., two species.
- Neolobophora*, Scudd., three species.
- Pygidicrana*, Serv., twenty-five species.
- Nannopygia*, Dohrn., two species.
- Cylindrogaster*, Stal., seven species.
- Diplatys*, Serv., four species.
- Echinopsalis*, Borm., one species.
- Echinosoma*, Serv., ten species.
- Pyragra*, Serv., five species.
- Brachylabis*, Dohrn., two species.
- Labidura*, Leach, twenty-five species.
- Psalis*, Serv., nine species.
- Labidurodes*, Borm., one species.
- Anisolabis*, Fieb., thirty-five species.
- Platylabia*, Dohrn., eight species.
- Chaetospania*, Karsch., two species.
- Sparatta*, Serv., fifteen species.
- Mecomera*, Serv., one species.
- Labia*, Leach, forty-two species.
- Spongophora*, Serv., twenty-two species.
- Chelisoche*, Scudd., twenty-two species.
- Auchenomus*, Karsch., two species.
- Ancistrogaster*, Stal., twelve species.
- Opisthocosmia*, Dohrn., sixteen species.
- Anechura*, Scudd., eleven species.
- Forficula*, L., forty-six species.
- Sphingolabis*, Borm., twenty-seven species.
- Apterygida*, Westw., four species.
- Chelidura*, Latr., eight species.
- Carcinophora*, Scudd., two species.

New College, Oxford; October, 1897.

(1) Proc. Zool. Soc., London, 1892, p. 396.

(2) Forh. Skand. Naturf., iv., 255 (1847).

(3) Zeitschr. Ges. Naturw., xxi., 219 (1863).

(4) Cat. Derm. Salt., 1871, v., Suppl., 2.

(5) Sharp, Ins. L., 217 (1876). (*Hemimerus taipeioides*,

Hansen, Ent. Tidskr., 1894, 65.)

(6) Trans. Ent. Soc., London, 1881, p. cxvii., fig. 1.

## THE KENT COAL-FIELDS.

BY EDWARD A. MARTIN, F.G.S.

(Continued from page 160.)

IN this number will be found a continuation (ante p. 160) of the sections met with in the successful boring after coal at Dover. Complete particulars will be now in the hands of our readers of the whole of the strata passed through to a depth of 2,221½ feet, where the four-foot seam of coal came to an end, the reaching of which

*scheuchzeri*. The former were represented by well characterized fragments of fronds, and the latter by large detached pinnules. M. Zeiller reported as to these, that "in France they abound in the upper zone of the Valenciennes basin, and they have not been met with below, except quite at the summit of the middle zone, and then at one or

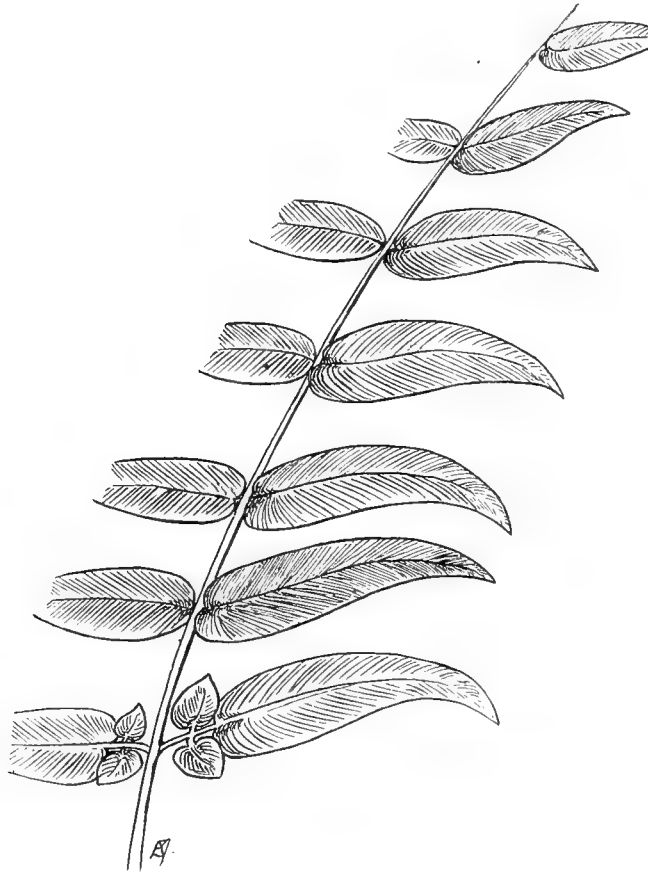

NEUROPTERIS SCHEUCHZERI.

From Upper Coal Measures at Radstock.

caused Mr. Brady to send his triumphant telegram to Sir E. W. Watkin, "Have found four feet seam of good bituminous coal at 2,222 feet from surface."

We have already viewed the various plant-prints which have been met with, and now illustrate the two fossils on which the relative position of the beds to the whole of the Coal Measures is based, namely, *Neuropteris varinervis* and *N.*

two points only." These fossils are common in the Radstock and Farringdon Beds, which appear to be "a little more elevated than the *grasses* and *flénues* beds of the Pas de Calais," from which it is considered that there may still be a great thickness of further coal-bearing beds below the coal of Dover.

Interesting facts which may bear upon the question of the westerly extension of the Dover

beds, have been brought to light by the labours of Professors Rücker and Thorpe, who have made magnetic surveys in various parts of the kingdom. Where there are masses of basaltic or similar rocks containing a large proportion of iron, the needle would naturally be seriously deflected; but when this phenomenon happened in districts where no such rocks were known to exist, and where the surface formations consisted of Tertiaries, or Secondary beds, such as Chalk, there seemed to be no other explanation than that there were some deep-seated ferruginous rocks further down, about which we possessed no knowledge. In speaking before the Society of Arts, of the magnetic examination of a region in the south of England, Mr. W. Whitaker, M.A., F.R.S., said that "the compass needle is drawn to a line which runs along the valley of the Thames to Reading and passes thence to South Wales, and possibly even to the South of Ireland. The most powerful effect was between Reading and Windsor," from which neighbourhood there were three secondary lines of disturbance, one southward to Chichester being the most clearly marked. From this it is deduced that Chichester may be at the southern end of

one of the north and south cross-lines of uprise of the more ancient Palaeozoic rocks, whilst Reading and Windsor are at the northern end. The last named two places being on the line traced from the Pas de Calais to South Wales, the district itself should be severely let alone by would-be coal discoverers, whilst efforts might be made to find coal not less than, say, some fifteen miles either east or west of it.

It was pointed out in last month's number of *Science-Gossip* that in view of Devonian rocks

having been found beneath London, there is but the slightest likelihood of coal being found around the metropolis. Either east or west of London a future coal-field may be discovered. Beneath London there is evidently an uprise of Pre-Carboniferous rocks, constituting a surface formed of the denuded edges of such rocks which had been brought up to this Palaeozoic surface by a series of crumplings, taking place prior to the Secondary strata being laid down. This uprise of

older rocks would be one of many which may occur at intervals along the whole length from Dover to the coal-fields of the West of England: the strike of such uprisings being, roughly speaking, at right angles to the main axis, *i.e.* north and south.

The rise of old rocks at Ware, in Hertfordshire, has been already referred to, as also to the trough which must then succeed in a northerly direction. Between Ware and the coast of Essex is an area to which a good deal of geological prominence has been given recently, owing to the labours of the Eastern Counties Coal-Boring Association. At Harwich some rocks had been bored into at a depth of 1,029 feet, which are considered to be either Lower Car-

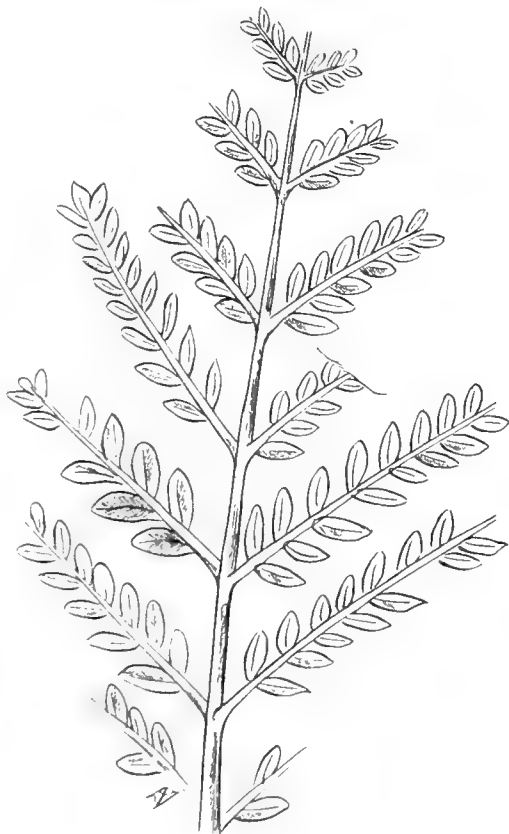

*NELLOPTERIS RAVINERVIS.*  
From Upper Coal Measures at Radstock.

boniferous or Pre-Carboniferous, and the efforts of the Association have been directed towards ascertaining by exploration whether Coal Measures can be met with at other points on the north side of the Thames. Interesting results have been obtained, although the Measures have not yet been hit upon. At Weeley, in Essex, Pre-Carboniferous rocks were reached at 1,094½ feet, and at Stutton a very similar rock was bored into at 1,004 feet, which, however, caused in each case the abandonment of the boring

in search of coal. Subsequently it has been announced that there appears to be a great similarity in the character of the Palaeozoic rock which was formerly pierced on Lord Cadogan's estate, at Culford, Bury St. Edmunds, and that reached at Harwich, with the cores brought up from Stutton and Weeley. It would seem, therefore that Essex has been placed out of the regions of possibility as a coal-producing area, although it is possible, that the boring now being sunk at Great Wakering, near Southend, under the advice of Messrs. Whitaker and Holmes, may prove more successful than those they have already made. All honour, however, to those who have spent their time and money in order to extend our geological knowledge of the eastern counties.

In addition to the borings which have been dealt with, others have been made at Ashford and at Chatham, both in Kent, neither of these, however, having reached coal-bearing beds. In the Chatham boring a great thickness of alluvial

clay was found resting upon the Chalk. In this, as Mr. Whitaker remarked in his paper before the Geological Society, was discovered one of the most remarkable fossils ever met with, viz., the remains of an old Dutch man-of-war, which in a dark period in our country's history had forced its way up the Medway, and threatened old England with invasion. Neither at Chatham nor Ashford were Palaeozoic rocks reached, but the former left off in Oxford clay at 965 feet, Geologists are now seeking knowledge as to the depths of the ancient rocks south-west of the metropolis, but with the exception of the boring at Richmond, we are very much in the dark with regard to them. Richmond gave us the base of Jurassic beds at 1,239½ feet, and if the red and grey clays and sandstones which then succeeded eventually prove to be Devonian, we have here an important link in our westerly geological chain,

69, Bensham Manor Road,  
Thornton Heath.

SECTIONS OF BORING, DOVER COLLIERY.  
(Continued from page 160.)

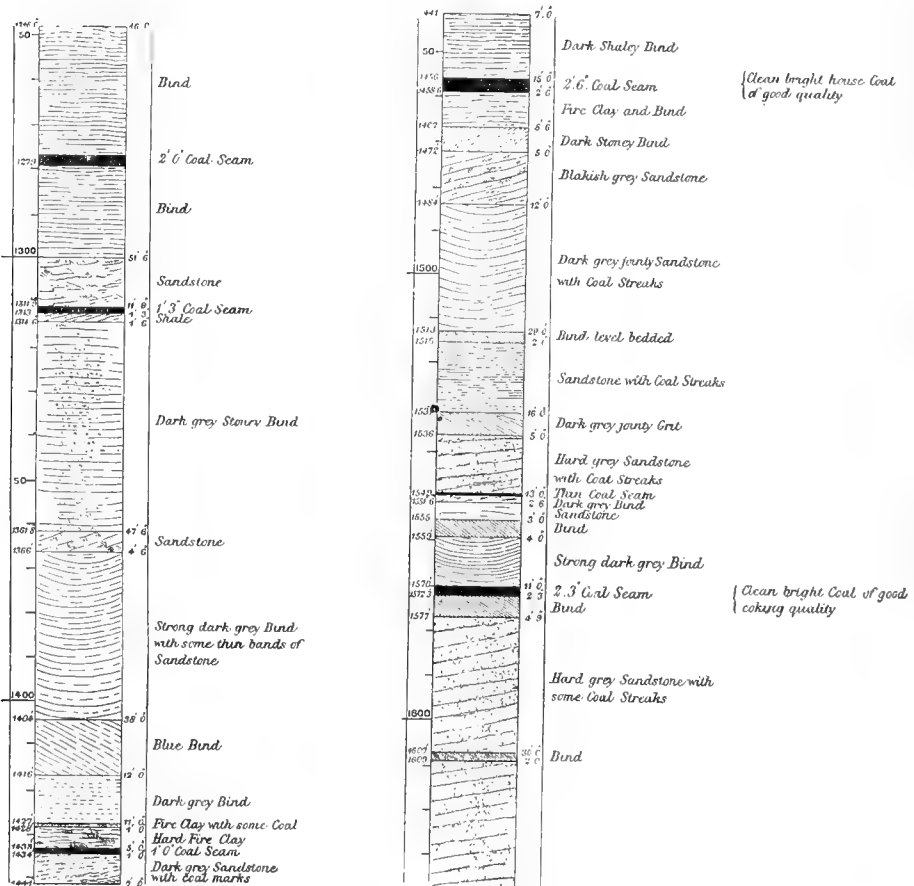





COLORATION AND VARIATION OF BRITISH  
EXTRA-MARINE MOLLUSCA.

BY ARTHUR E. BOYCOTT.

(Continued from page 163.)

I HAVE omitted to mention that in measuring very flat forms, such as *Planorbis*, two altitudes should be taken: one in the centre, down the columella (this is conveniently done with the curved limbs of the Boley gauge); the other, the greatest thickness of the last whorl (with the flat limbs). The former might be called the "apex," the latter the "total height." The same thing holds good for such involute forms as *Limnaea peregra involuta* and some forms of *auricularia*.

For the study of variations in colour no satisfactory plan seems to have been devised. Descriptions of colours in words are all very well, but it is difficult to define the exact tints conveyed by such terms as "reddish," "dark olive," "pinkish," or even "brown" or "red." A universal colour scale would be very convenient if it included the tints of shells. Roughly and generally, of course, there is little ambiguity.

Weight is easily determined by a balance <sup>(1)</sup>. It is well to weigh to milligrammes (0.001 grms.), but unnecessary to go beyond centigrammes (0.01), in the case of the larger species at any rate. The difficulty of getting the shells quite clean, and at the same time quite unbroken, renders too refined weighings useless. Indeed, it is very doubtful whether in the case of *Tachea*, for instance, the weighings can, as a rule, really be trusted below centigrammes. A very small bit of "body" left inside makes much difference. The degree of dryness of the shell of course introduces a source of error; it is most convenient not to weigh any which have not been cleaned out at least some months. After this period the weight probably keeps fairly constant, if one may judge from a short experience of two years or so.

After these preliminary observations on method, it will be well to consider what is known about the normal form and coloration of our British extra-marine mollusca, before going on to consider the many variations in these respects which are found.

The normal gastropod shell-form is perhaps a rather short, wide cone, as found in *Helix*. The original form was presumably something similar in external shape, but simple, without any convolutions, such, in fact, as is found in *Patella*, *Ancylus* and *Dentalium*, e.g., at the present time. The heliciform, coiled, spiral shell can have arisen from an elongated

cone like *Theca* (Cambrian) or *Dentalium* (1) by coiling in one plane, eventually giving rise to a *Planorbis* shape, which, by an elevation of the central apex from the plane of the shell and a descent of the last whorl, gave the *Helix* form <sup>(2)</sup>; or (2) by coiling in a spiral form, which by compression produced a *Helix*, and, by further compression, a *Planorbis* shape. The former view has been advocated by, e.g., E. W. W. Bowell <sup>(2)</sup>, the original incurving of the cylindrical, tapering, simple cone being due to "mechanical convenience"; it is supported by the fact that instances where a long cone is curved in one plane at one end are found in recent and fossil forms. *Caecum trachea*, for instance, when young exhibits just the hypothetical bending in at one end, while the rest remains a straight tube. *Crioceras*, *Ancyloceras* and *Hamites* (from the Gault) exhibit similar forms with varying details among the Cephalopoda, which, it may be noted, also show *Planorbis* and *Helix* forms of shell. On the other hand, the second view is supported by such palaeontological specimens as *Hebiceras* (Gault), or the recent *Cylindrella*, and by the scalari-form variation which now so often occurs (this may be due, of course, to pathological causes), and perhaps further by the spiral form of the embryonal shell in such highly modified forms as *Ancylus*, *Fissurella* and *Limax*. This, again, may be but an indication of the spiral form from which they have doubtless been immediately derived. It appears that the former view is generally held, and Tryon <sup>(3)</sup> seems to agree with it.

In whatever way the spiral shell and the torsion of the visceral hump has been produced, however, it seems that the somewhat globose shape, as represented in *Tachea*, combines great strength with a comparatively thin shell. Shells of this shape (*Cryptomphalus*, *Helix* (restricted), *Tachea*, *Xerophila*, part) often live in open places, where their chance of receiving various knocks is a very good one, and it requires some pressure to crush a well-grown *Tachea*. Thin elongated shells are often of use to snails in making their way about in nooks and crannies, among stones, under bark on trees, etc. This is the case with *Clausilia*, *Balia*, etc. A great reduction in the size of the shell enables

<sup>(1)</sup> Some specimens of *Pl. cornus* (Oxford) look as if they were trying to do this now.

<sup>(2)</sup> SCIENCE-GOSSIP, June, 1892.

<sup>(3)</sup> Struct. and Syst. Conch. (1882), i., p. 37.

<sup>(1)</sup> F. E. Becker and Co., Hatton Garden, London, E.C., supply a simple, cheap form admirably adapted for the purpose.

the snail to penetrate small holes, and, in the case of *Testacella*, the most familiar instance, to follow worms down their holes, and so secure food.

The shell may become partially covered by the reflexion of the mantle (*Vitrina*, *Physa*, *Amphiflexa*), which leads to total inclusion (*Limax*), and consequent atrophy (*Atrion*). This loss of the shell is generally followed by a compensatory adaptation for protection, such as great capacity for regeneration, and colouring which may be protective in various ways (1). It is to be remembered that the bilateral symmetry also arising is only external, never internal.

The patelliform shell, exhibited in the fauna we are considering by *Ancylus*, is very widely distributed throughout the mollusca, in various groups, both recent and fossil, e.g., *Patella* (also under this name from Oolite), *Ancylus*, *Pilcolus* (Oolite), *Cardiola* (Silurian), etc. This shell form is an advanced modification; *Ancylus* and *Patella* have an embryonal spiral shell, and the flattened cone is a new acquisition, modified for a sedentary life amid quick currents. *Ancylus fluviatilis* lives in security on stones exposed to streams of very considerable violence. *Neitina* is similarly modified, as far as its external shape goes, and enjoys the same advantages in similar situations; *Navicella* is much the same (2).

Turning now to the coloration, we may commence by studying the coloration of the shell in those forms which bear it externally (3). Roughly speaking, by their coloration, the British terrestrial species (which may conveniently, though not in many cases very properly from a morphological point of view, be examined apart from the aquatic forms) may be divided into two main groups, with further sub-divisions, as follows:

(1) MONOCHROMATIC. The prevailing tint may be:

- (a) Brown and "horn-coloured" of various shades. *Hyalinia* (except (4) *puva*), *Conulus*, *Patula rufestris* (?), *Functum*, *Acanthinula* (? *lamellata*), *Trigonostoma*, *Fruticicola rufescens*, *F. hispida*, *F. granulata*, *F. revelata* (greenish), *F. fusca*, *Buliminus*, *Pupa*, *Vertigo*, *Balca* (sometimes with a faint greenish tinge), *Clausilia* (very dark, sometimes slightly variegated with white), *Azeca*, *Cochlicopa*, *Succinea*, *Acteola*. Some of these are variegated with coloured peristomes (e.g., red in *Cochlicopa*, white in *Clausilia*, occasionally a

red rib in, e.g., *F. hispida*), but this is very largely invisible externally. Some *Hyalinia* have their underside of a clear, bright white.

- (β) White: *Hyalinia puva*, *Discus* (*Vitreata*), *Valtonia*, *Fruticicola cantiana* (generally with a strong reddish tinge), *F. carthusiana*, *Caccolioides*, *Carychium*, and white varieties.

(γ) Green: *Vitrina*; slightly, *Fruticicola revelata*.

(2) OLIGOCHROMATIC.

(α) Of dull, lugubrious colours, mostly browns: *Patula rotundata*, *Chilotrema*.

(β) Of brighter, often paler, colours: *Helix* (*pomatia*), *Cryptomphalus*, *Arianta*, *Cyclostoma*.

(γ) Of a general coloration of black and white: *Xerophila*, *Cochlicella*.

(δ) Of comparatively bright colours: *Tachea*.

Of course, these groups run into and overlap each other. For instance, *Cryptomphalus* may be practically monochromatic (black or yellow) on the one hand, while at the other end we find specimens (var. *tigris*) which rival *Tachea* in the brilliancy of their tints.

According to the general rule, that in animals of very small size significant coloration does not exist (1), or at any rate is not recognizable, we may leave such genera as *Carychium* and *Vertigo* out of consideration. According to another general rule, viz., that bright varied colours are not developed except in those species which live fairly freely exposed to light and warmth, we should naturally expect the group with dull, monochromatic shells to live in dark, damp situations. This is actually the case: they live under stones, under bark on trees, among dead and rotten leaves, and in similar places, from which they only emerge on damp days, when the sun is obscured, or during the night. This explanation will not, however, suffice for all the species included in the first group: *Fruticicola cantiana* lives very much in the open, and is really comparatively brightly coloured; *F. carthusiana* leads a still more exposed life, and will be dealt with later. *Succinea* lives in the open in great measure, and its shell may possibly be explained in the same way as *Limnaea*, it being always a possibility that it is derived from the aquatic Pulmonata (see below). *Fruticicola rufescens*, e.g., really moves about just as much in the open as *Cryptomphalus*, and very nearly as much as *Tachea*. After rain in the daytime, it and *Tachea* are often found swarming together on nettles, crawling about quite freely, when *Fruticicola hispida*, etc., have not yet emerged. It has a rather thicker shell than the other members of the group.

The next group we may take up is a very well defined one on the whole. It contains the four *Xerophila* and *Cochlicella*, to which may

(1) Cf. Arnold Lang, *Comp. Anat.*, vol. II, p. 57 (Eng. Trans.), 1897.

(2) See K. Semper, "Animal Life" (1879), pp. 293, 459.

(3) As far as I know, the internal shell in slugs is never pigmented. Of the color of the rudimentary (atrophied) shell of *Testacella* there seems nothing to say; it harmonises with the colour of the rest of the animal in an unusual way.

(4) Since *puva* is so near the nitidula group (*C. radulae* in *Science-Gossip*, N. S., IV, 1897, p. 6, E. W. W. Bowell), it seems more reasonable to regard the brown (*nitidula*) form as normal, though the white one was first described as *puva*, and so is, in one sense, "typical."

(5) "In form *Vertigo*, and many other small forms have a certain resemblance to the unopened shoots on twigs of *Crotacrus*, etc."—E. W. W. Bowell.

be added *Fruticicola carthusiana*. Characteristically they have thick (1) shells of a white and black or brown colour, the white, however, predominating, and occupying the whole surface of the shell in *F. carthusiana* (?). The habitats which they affect are no less characteristic than their general appearance. They are found in open, dry situations, freely exposed on the scanty herbage to the full blaze of the sun on a hot day (?), and with little protection beyond their shells to equally intense cold. It is to be supposed that their pale coloration combined with their thick shells is of direct physiological value in withstanding the extremes of temperature to which they are subjected. The whiteness enables them to absorb less heat on a hot day and give out less heat on a cold day (?). It must be remembered

(1) The apparently greater thickness, which is so obvious, is borne out to a large extent by actual measurements. The following table gives the approximate measurements of ten species. The numbers are averages of a varying number of specimens taken at random from those which happened to be at hand. The thicknesses were measured in several places on the body-whorl in each specimen, near the mouth, but excluding the peristome and rib. The method of comparison in the last column is open to the objection that the various species differ in shape.

Species.	Diam. mm.	Alt. mm.	Thick- ness. mm.	D × A.	
				Th. × 10.	D. × A.
<i>T. nemoralis</i> ...	21.6	16.9	0.25	146	365
<i>T. hortensis</i> ...	18.7	14.0	0.21	125	262
<i>F. rufescens</i> ...	12.3	7.6	0.175	53	93.5
<i>F. cantiana</i> ...	17.6	12.15	0.24	89	214
<i>Ch. lapicida</i> ...	17.6	7.6	0.19	70	134
<i>X. pisana</i> ...	17.3	13.4	0.23	101	232
<i>X. virgata</i> ...	13.1	9.9	0.22	59	130
<i>X. ericetorum</i> ...	18.0	9.7	0.13	134	175
<i>X. caperata</i> ...	9.1	5.6	0.13	39	51
<i>F. carthusiana</i> ...	11.7	7.0	0.12	68	82

Besides showing that larger shells are proportionately thinner than smaller ones, it will be seen that the first five species are, on the whole, thinner than the last five ( $\frac{\text{diam.} \times \text{alt.}}{\text{thickness} \times 10}$  96.7, as against 80.2). Moquin-Tandon ("Histoire," i., p. 292: 1855) quotes a species pre-eminently not belonging to this group as the thinnest (*Fruticicola fusca*), and one pre-eminently belonging to the group as the thickest (*Leucochroa candidissima*). Mr. Bowell tells me that some *Leucochroa* which he has examined do not run beyond 0.5 mm. thick. These two species are especially instructive, as while *Leucochroa* is not a *Helicella* (= *Xerophila*), *Fruticicola fusca* is not far removed from that group; their physiological does not correspond with their morphological anatomy, but is just reversed, and such questions as the present belong to physiology.

I am indebted to Mr. Bowell for the following brief summary of the morphological relationships of four English Helices. "The genera *Punctum*, Morse (*P. pygmaeum*, Dr.) and *Pyramidula*, Fitz. (*P. rupestris*, Dr., and *P. rotundata*, Mull.) belong, as Pilsbry has most conclusively shown, to the Endodontidae, and are quite distinct from our other Helices. To quote: "This family is intermediate between Zonitidae and Helicidae in its characters, and it is decidedly less specialized than either. While it may not be in the direct line of descent of these two families, it is certainly nearer than either of the others to the common ancestor of the three, as is shown by its unspecialized jaw, teeth, genitalia and shell. Palaeontology has yet given but little to the history of the group, but that little is significant; the Carboniferous of Nova Scotia has afforded a small Helicoid described as *Zonites priscus*, Cpr., which in form and ribbed-striate sculpture can only be compared to such Endodontidae as *Pyramidula* or *Charopa*." ("Guide to Helices," Introd., p. xxxix.) If we also eliminate for separate consideration the genera *Acanthinula* and *Vallonina*, which in all probability belong to an older fauna, the remainder of our "Helices" fall naturally into three groups: (a) The most highly developed Helicidae are represented here by the forms *aspersa*, *ponatia*, *nemoralis* and *hortensis*. Pilsbry has, I think rightly, reduced the names *Cryptomphalus*, *Helicogena* and *Tachea* to the level of "sections," retaining the old generic name "*Helix*" for the species formerly known under these names (together with

that in large, arid desert areas,—the Sahara, to take an extreme instance,—though the temperature may rise very high during the day, at night it goes to the other extreme, and animals have to make themselves secure against the attacks of frost. This pale mode of coloration is the one characteristic of desert species, as seen in *Helix desertorum* (6) or *H. lactea*. That they flourish in such situations is shown by the fact that specimens from the Algerian Sahara are actually larger than the ordinary European form of the same species.

It has been made out that widely distributed species, such as *Helix pomatia*, *Xerophila pisana*, or *Leucochroa candidissima*, from desert localities, are thicker than the type, and tend to lose all trace of coloured bands (6). Just as we find these modifications strongly accentuated in localities which are

a number of allied species, of course). *Helix pisana*, Mull., though apparently a very degenerate or much modified form, seems best placed here. (Pilsbry gives *Enparapha* as a subgenus to mark its aberration.) (3) *Helicigona*, Fér., is a very distinct genus, quite unlike *Helix* ("Guide," p. 297), as indeed anyone may convince himself by dissecting either of our two native species (*lapicida* and *arbutorum*) and looking at the large simple mucus ("digitate") glands. The form of the spiculum is also characteristic, and that of the diverticulum (enormously large) betrays *Helicigona* at once. The only other European species are *quimperiana*, Fér. (= *kermorvian*, Moq.); the species of the *raspailii* group (all from Corsica and Sardinia); the Alpine species of *Chilostoma*, and certain forms like *H. aethiops*, Blz., which are closely related to *arbutorum*. The variation in form and colour in this genus may be compared with that obtaining in *Helix* and in our third group; nearly everything may be paralleled—conoidity, globosity, planorbiformity; or brilliancy of decoration, or quiet colouring. But we do not find the extreme of brilliancy nor that form of shell which Mr. Boycott, rightly, I think, regards as most perfect, to the same extent as in *Helix*; and a still less specialized series is found in (v) the genera *Helicella* and *Hygromia*. With the latter we may class *Helicodonta obvoluta*, Müll., which, though aberrant, is clearly connected with it. *Hygromia* is the earlier genus of the two, and comprises our species *fusca*, Mont., *granulata*, Ald., *hispidula*, L., *revelata*, Fér., and *rufescens*, Penn. (according to Pilsbry, though I think the latter should belong to the *Theba* group). In *rufescens* we see the beginnings of real colour variation, and that part of the genus *Helicella* known under the subgeneric name *Theba* (our species *cantiana*, Mont., and *carthusiana*, Müll.) naturally follow the lead of *rufescens* and exemplify in all probability the mode of origin of banding in the Helicidae. *Theba* is a section of *Helicella*, which contains our remaining Helices, viz., *variabilis*, Dr., *virgata*, Da C., *ericetorum*, Müll., *caperata*, Mont., and the aberrant form *acuta*, Müll. This classification was based upon anatomical considerations, but it will be seen that it greatly assists the study of the shell. For example, in the *Hygromia-Helicella* section we meet with much greater diversity than in the other two: anatomically we find the flagellum short, except in one species (*Helix fusca*, Mont.); some species have two spiculae, others one, and others again (*carthusiana* (?) *acuta*, *revelata*) none. In the relative size of parts there is the greatest variation even between apparently closely allied species; in the shells nearly all the further developments of the true *Helix* are hinted at. Many of the species seem to retain the migratory habits which doubtless characterized the ancestors of the Helicidae, and the gregarious character of all may probably be another sign of "ancient lineage."—E. W. W. B.

(2) I am not inclined to include *Fruticicola cantiana* (a *Helicella*) in the group; its habits and habitats are much more like those of *Tachea* than *Xerophila*.

(3) For this in *Fruticicola carthusiana*, see L. E. Adams, Journ. of Conch., viii. (1896), p. 319.

(4) Readers need not be reminded that the temperature of Mollusca is always slightly above that of the surrounding air, at least within the ordinary range of variation.

(5) This also may well be cryptic on sand.

(6) A. H. Cooke, Cambridge Nat. Hist., iii., pp. 25, 85. (1895), cf. also J. W. Taylor, Journ. of Conch., v., p. 297.

exactly calculated to produce them, so we find the same species on our English commons offering the same modifications, but in a less degree when compared with the ordinary run of dark- and damp-loving species. That the disadvantages of temperature under which species from arid situations labour are fully compensated, is shown also by the extraordinary abundance in which *Helix lactea*, *H. desertorum*, as well as *Xerophila* in England, occur in such situations (1). Strobel has shown that exposure to dryness and warmth induces leucochroism in *X. virgata* (2).

The thick shell also serves the same end by hindering evaporation (3). The increase in thickness, as pointed out above, is really not very great. It is possible that the question of opacity is of importance. All, except in a small degree *Xerophila ericetorum* and *Fruticicola carthusiana* (4), are practically opaque; but there is no necessary dependence of adiathermacy or opacity, and there seems to be no data on which to come to a conclusion on this point.

It is an old observation of Bouchard-Chantreaux that *Xerophila virgata* never hibernates, and the statement has been repeated on his authority in several places (5). There are some grounds for supposing that this is not strictly so as applied to the whole group. For instance, J. W. Horsley (6) has recently recorded *Tachea hortensis* well out and active in April, while *Xerophila virgata* and *caperata* were still hibernating. I have myself noticed during last winter (1896-7), which was a very mild one, that a colony of *X. ericetorum* were hibernating in comparatively warm weather. They were first observed (near Kenchester, Herefordshire) on October 9th, 1896; but no live specimens could be found on November 9th, nor again in December. It is possible that this phenomenon was due to the fact that they occurred on an ordinary hedge-bank, and the ground-colour of the shells, which were very thin, was certainly not white (7). On the other hand, I have seen *X. caperata* crawling about on moss when snow lay quite thick on the ground.

(1) Cf. Westerlund's "Fundamenta," pp. 31 ff. L. E. Adams has found *Xerophila caperata* on the desert at Bagdad (Manual, ed. II, p. 6, 1896). See, generally, E. B. Poulton, "Colours of Animals," pp. 15-19 (1899).

(2) J. W. Taylor, "Monograph," I. (1895), p. 93.

(3) It is noticeable that the var. *subrufa* of *Fruticicola hirsuta* is defined as being "more solid" and inhabiting "dry situations" (J. G. J. Freys, B. C. I., p. 199), an observation which I can confirm.

(4) Especially in some localities. It is frequently quite opaque white.

(5) e.g., J. G. Jeffreys, B. C. I., p. 212.

(6) Journ. of Conch., VIII, p. 211 (1896). Chas. Ashford does not confirm B. Chantreaux' statement, Journ. of Conch., III, p. 152.

(7) This species is never so white and black, or so thick, as the others. Hence it may not exhibit the characteristic reactions so well. It is noticeable that *Xerophila* will stand desiccation in a dry pul-box for a longer time than, e.g., *Fruticicola* or *Hyalina*.

F. V. Theobald (1) confirms the statement that *X. virgata* does not hibernate; and Mr. E. W. W. Bowell tells me that near Sissinghurst, Kent, he finds that though *X. virgata* "is to be found in the depth of winter, it disappears in March and April." There thus seems some grounds for supposing that these snails can withstand, with comfort, a considerable degree of cold.

Albinism, which is a more frequent mode of variation in these six species than melanism, is an accentuation of their normal tendency, and only further adapts them to their manner of life by the methods indicated.

Regarding the form with a white ground-colour with a few definite dark-brown or black bands as the typical one (2) in this group, we find that it is an uncommon one in *X. caperata*. This species very frequently, normally in fact, has the band above the periphery (i.e. the most conspicuous one) broken up into spots; and while this mottled form often has a white ground-colour, it is very frequently a rather dirty, dingy yellow, in which case also the markings may be dull and ill-marked or even absent. This form occurs in places other than those in which *Xerophila* is normally found. It occurs on hedge-banks and in fields where the herbage is long and coarse, and is by no means confined to situations which have a mere skin of vegetation. Hence it is not so much exposed to heat and, in a less degree, to cold as the others. So far from suffering any great hurt in this direction from its loss of albinism (3), it seems to derive an immediate gain. This is the only case I have personally come across where cryptic coloration, real or supposed, has deceived me. I have repeatedly, in localities where this dull, dirty-yellowish, more or less monochromatic form occurs, mistaken for shells the withered heads of flowers, e.g., *Centaurea nigra*, broken ends of bits of stick, and other objects of a similar appearance. The mottled form, with a bright white ground-colour, affects open situations on bare banks, and especially, as far as my own experience goes, quarries, where it is a conspicuous object. Especially is this so where it occurs in myriads on some dry gravelly place with scarcely a single blade of grass. The number of dead specimens occurring in these situations is remarkable.

S. S. Pearce (4) has carefully studied the form

(1) "Zoologist" (3), xix., p. 207 (1895).

(2) S. S. Pearce (Journ. of Conch., vi., pp. 123-135) considers that all forms of *Xerophila caperata* are derived from a uniformly brown shell, and that the *ornata* form arises from a fusion of mottled markings. C. Ashford (ibid. II, pp. 89-95), on the other hand, holds that the band above the periphery is splitting across into beads and disappearing. "The discontinuity of the bands in *caperata* appears to be largely due to the heavy striation of the shell."—E. W. W. Bowell.

(3) Which may be increased by a superficial coating of dirt.

(4) Journ. of Conch., loc. cit.

*ornata* of this species, and comes to the conclusion that it is sematic to sheep. He supports this theory with the following very remarkable facts. In five sheep pastures on the south coast the *ornata* were 46 per cent. of the whole number of *capervata*; while in four pastures in which sheep never fed, but which were otherwise apparently similar in character, the *ornata* only amounted to 5 per cent. Again, in two areas of the same size (seven square yards) on the Isle-of-Wight downs, all the *capervata* were collected. In the one in which sheep fed the *ornata* were 61 per cent., while in the other, from which sheep were absent, they only amounted to 22 per cent. of the total number. This is very strong evidence that the *ornata* form is only extensively developed, at any rate, in the kind of localities examined<sup>(1)</sup>, in such places as are habitually frequented by sheep. The natural inference is that the colouring is sematic, and by its means the snails avoid being eaten by the sheep. It is only natural, though it may be wrong, to suppose that sheep would prefer not to eat snails if they could help it, though in some localities they throng the herbage so thickly that it must be a matter of considerable difficulty to get the grass without the snails. It is an old idea that Dartmoor mutton owes its delicate flavour to this strange diet of *Xerophila capervata*, *X. virgata*, etc.<sup>(2)</sup>. It is very possible that the bold markings of *X. virgata* do a similar service to this very conspicuous species; though as forms with other markings than bands are comparatively rare, the proposition does not admit of the same demonstration as has been given in the case of *X. capervata*.

I suspect, too, that these black or brown and white banded species may be generally cryptically coloured. It is my experience, at any rate, and that of one or two others of whom I know, (especially with *X. ericetorum*; *X. virgata* is easier to see) that however well the collector knows the shape, size and colour of the species he is looking for, or however plentiful they may be, till he catches sight of one, the ground looks quite fruitless. When one is seen, one finds out how numerous they really are. This is an example which shows how cautious we must be in saying that any coloration is, or is not, cryptic. It is said that the zebra, with its bright colours and vivid, striped contrast, is very hard to see in the dusk, apart from any question of striped surroundings. So it would never be imagined, from looking at the two things apart, that the black and white of *Xerophila* would harmonise in the slightest with the greens and browns of the surface on

(1) In Herefordshire, on road banks and in quarries, the *ornata* form comes to about 35 per cent., that is, less than *fulva*.

(2) Borlase (1758), quoted by J. G. Jeffreys, B. C., i., p. 212. J. E. Harting, "Rambles in Search of Shells," pp. 75-76.

which it lives. All the same, there are reasons for thinking that practically there is a concealing resemblance between these shells and their surroundings. There is also another caution to be borne in mind: although they may not be obvious to us, they may be plain enough to birds. Conversely, a shell which we find no difficulty in seeing may be cryptically coloured with regard to the vision of its natural enemies—birds<sup>(1)</sup>, voles, etc.

## OUR BOTANICAL COMPETITION.

WE cannot pretend to disguise our disappointment at the result of our offer of prizes for a botanical competition, aided by photography. The number of competitors who have sent in examples of their work are far below the limit of ten as set forth in our rules on page 46 in this volume.

One cause of the small number of competitors was, doubtless, the lateness of the season when the offer was made. Still, those examples we have received are so interesting and have evidently caused such pleasure to the students in botany who have prepared them, that we feel we were right in making the offer. One competitor expresses his "real pleasure and interest in the work, first in seeking out the plants for subjects, then in preparing the pictures, and lastly, in the preservation of the plants for identification." This gentleman's work is so good we sincerely regret the insufficient number of competitors makes it impossible to give the prizes.

We, however, shall have pleasure in sending to Mr. W. P. Winter, The Science School, Cheltenham, a consolation prize, his work having been the best. The plants selected by Mr. Winter are more local than rare. His conception, however, of the requirements under the competition is so clear, that we feel we should not let his work be wasted through no fault of his own. Mr. Winter's plants are the deadly night-shade (*Atropa belladonna*), mountain cranesbill (*Geranium pyrenaicum*), and snakeweed (*Polygonum bistorta*).

Although we have failed this season in drawing ten competitors, the result is so satisfactory we shall next year offer a similar competition with like prizes.—ED. S.-G.

ARMATURE OF HELICOID LANDSHELLS.—Mr. Gude's instalment of this series of articles upon the armature of landshells unavoidably stands over until next month.

(1) Is it quite certain that birds do eat *Xerophila* freely, and that the colours are not sematic? I have never noticed any shell unequivocally broken by birds, but my opportunities for watching the genus have not been very large. J. G. Jeffreys (Trans. Linn. Soc., xvi. (1833), p. 334) has observed that *X. pisana* are largely destroyed by birds at Tenby; and *X. capervata* has been taken alive in a wood-pigeon's crop.—H. W. Kew, "Dispersal of Shells" (1893), p. 161.

## THE ROCKS OF THE ISLE OF MAN.

BY FRED. J. GRAY.

TO the petrologist in general and the student in particular the Isle of Man affords a very good field for practical work. One may, with great advantage, realise the ideas received from different text-books on rocks, and institute comparisons between the illustrations contained therein and the actual scenery and rocks found in rambles through the island. No matter how descriptive and minute in explanation be the text in such books, or how excellent the diagrams or sketches, they do not give anything like such a good idea, or fix themselves so firmly in the memory, as one look or practical examination of the rocks as they stand where Nature placed them.

Three of the great geological series are represented in the Isle of Man, viz.; Lower Silurian, Carboniferous and Pleistocene, in addition to which there are rocks which may represent the Devonian and Permian series. From a palaeontological standpoint the place is equally good, the Carboniferous and Pleistocene yielding many fossils, amongst them being found examples of Pisces, Cephalopoda, Gasteropoda, Coelenterata, Echinodermata, Crustacea, Annelida and Cirripeda; flints and fossil mammal remains having also been discovered. The petrological specimens include varieties of granite, greisen, pegmatite, aplite, diorite, basalt, volcanic-ash and agglomerate, felsite, greenstone, clay, slate and ironstone. The shores near the different towns abound with pebbles of various rocks and minerals. So that, on the whole, one is fortunate who is able to spend a time devoted to the study of petrology, through the rocks of this island.

To see examples of these rocks, however, one has to leave the beaten tracks, and a large amount of walking is in many cases necessary. This is nothing to the enthusiastic student, even though weighed down with bag of specimens, hammer, etc. It is well worth the trouble, for the natural result is that one sees the grand and rugged scenery, whilst we find body and mind alike strengthened, and secure material for future study.

The influence of geology on scenery is of course always very great, but at the Isle of Man this is everywhere exceedingly well exemplified. Most of the mountains are rounded, presumably by ice action. The shore scenery varies with the rocks. At Douglas, Laxey, Port Erin, and elsewhere, the cliffs, which are of the Silurian rock, are high, grand and rugged. At Castletown and Langness we have contorted clay schist, Carboniferous Limestone and conglomerate, with the basaltic sheet known as Scarlet Point, the long, low cliffs at

Langness Point and peninsula being a notable example of the clay schist. To the north of the island the Pleistocene succession is found, and here we have a low shore of boulder clay and drift, and at the point of Ayr a flat area of sand.

The southern three-fourths of the island being composed of the Lower Silurian rock elevated into mountains, there are many valleys and glens, some of extreme beauty, and the mountain streams contain numerous waterfalls and cascades, for which the island is justly renowned. Having introduced the subject, I will pass on to a more detailed account of it from a purely petrological point of view.

The principal rock of the island belongs, generally speaking, to the Lower Silurian series, being usually correlated with the Skiddaw slates. This rock is found to make up practically the southern three-fourths of the isle, being found at the Calf of Man and Langness Point, and extending as far north as Ramsey. It is also found at Douglas and Laxey on the east, and at Port Erin and Peel on the west. The rock is not, however, exactly the same at all these places. It varies in colour, texture, bedding and other characteristics. Douglas Head is a mass of dark-coloured, hard, contorted shale, or clay schist, the beds being arranged at all angles, and much faulted. At Laxey, the beds are all conformable, fairly hard, of a light-grey colour, and generally more slaty in appearance. At Langness there is a great difference. There we have contorted clay schist again, but of a brilliant claret colour in some parts, and a light bluish-green in others, all soft and shaly, and very easily broken, hardly requiring the use of the hammer.

The second series in point of area represented in the island is the Pleistocene, which covers the entire northern portion. A certain amount is also found near Laxey and Castletown, and a band of this formation extends across the isle from Douglas to Peel, where it forms a valley between the high ground and mountains of slate already referred to. Along that valley the railway and road to Peel both pass.

A further stratigraphical series of which beds are found is the Carboniferous, this being represented by the Mountain Limestone, which occurs between two places, viz., Castletown and Ballasalla, and a very small patch found at Port St. Mary. This limestone is exceedingly plentiful in fossils, a great number having been chronicled. To the west of Castletown and at the head of Poolvash Bay is a small quarry of black marble. To the north of Peel Bay there are found beds of sandstone and conglomerate of a red colour,

and about which opinions are divided, some assigning them to the Devonian series, and others to the Permian. These beds will be again referred to when this locality is dealt with.

Having discussed the sedimentary rocks, I will now briefly mention the igneous rocks. Volcanic, Plutonic and Intrusive are all represented. The former has a grand example in the Scarlet Stack and Scarlet Point, a huge sheet of basalt. The plutonic rocks have their principal representatives in the granite "bosses" at Foxdale and Dhooon Glen, and in connection with which there are many examples of aplite, pegmatite, greisen, etc.; one or two exposures of diorite being found on the Langness peninsula. Intrusive rocks are abundant in all the older rocks of the Island, and are, generally speaking, trap, felsite, and quartz porphyry.

For the purpose of relating the more minute geological features, I think it better to describe them under the heading of excursions to the different localities, instead of grouping them together in their series or otherwise, and this I will now do, commencing with the little glen and bay at Groudale, a short distance to the north of Douglas.

#### EXCURSION TO GROUDALE.

The cliffs at Groudale are the usual Silurian rocks already referred to, and resting thereon is a great thickness of glacial drift. At one point it is from fifteen to twenty feet in depth, and there is no doubt it was very much more. It is exposed to this depth near the "Sea-lions Cave," where it has been excavated for the purpose of laying a miniature railway. A very noticeable feature of this drift section in particular is the variation of the matter composing it, being really made up of different beds. On the top is a light-coloured clay, full of pebbles of granite, trap, slate, etc. Then comes a bed of dark-coloured stiff clay, without any pebbly constituent. There again is another bed similar to the first mentioned, but of a coarser character, and containing some fairly large boulders. This difference does not extend any great distance, the middle bed gradually thinning out, and the other two coming together. The headland on the top of which I observed this section is called Clay Head, I suppose in allusion to its immense covering of this material.

In the Groudale Glen there is an instructive example, though not a very large one, of a cañon. A small stream coming down the mountain to join the larger stream in the glen has cut its way deep through the slaty rock. Here we have a good instance of water-wearing action alone, atmospheric agency not having done much, as the sides of the cañon are practically vertical, at some points being twenty to thirty feet in height. In this place there are several small cascades and

waterfalls, showing the difference in the hardness and texture of the rocks, some wearing away a great deal faster than others.

At the Groudale Bay there is a small example of what is probably at times a "storm beach." The shingle is thrown back from the shore and forms a bank across the mouth of the stream which flows through the glen. The water gradually finds its way through this block of shingle, but its transporting power is very much reduced, the shingle bar acting as a filter, and the stream has to deposit all large matter inside the bar, thus lengthening the bar up-stream and tending to the formation of a lake. As, however, the bay and stream are so tiny, there is not much chance of any great geological change; but the example is an instructive one to the student.

#### EXCURSION TO LAXEY.

Probably the first thing one notices, when strolling along the shore of Laxey Bay, is the greenish colour and comparatively coarse nature of the sand. On examining a small quantity of this under the microscope, it is found to consist of particles of quartz, both the opaque white variety and rock-crystal, slate, copper ore, lead ore, etc. The greenish colour is imparted by the grains of slate, lead and copper ore. Here one can well observe how the material of the locality is being prepared and laid down to form what will in future geological ages probably be a sandstone or gritstone. The particles of slate are derived from the break-up of the adjoining cliffs, the copper, lead and quartz being produced from the numerous veins which intersect these rocks in all directions. The stream which flows through the Laxey glen no doubt acts as a great transporter of material from the high ground which terminates in the Snaefell mountain. The operations of the Great Laxey Mining Company, and the Snaefell Lead Mining Company, where the deplorable disaster took place some time ago, doubtless add to the deposit. The coarse nature of the sand is probably due to the fact that the bay is a rather secluded one, the wearing action of the waves being thereby reduced.

The prevailing rock at Laxey Bay is, again, the Silurian slate or flag; the beds dipping towards the sea at a fairly high angle. The colour is dark-grey; it is hard, and regular in bedding. On breaking some of these, I once found what might have been a fossil of some kind, but of what I could not then make out. Since then I have heard that certain marks in these rocks were examined by Mr. J. Taylor, in 1862, and Mr. T. Grindley, in 1865; and had the impressions been discovered in later strata, they would no doubt have been taken for footprints. What I found was a small oval patch of a lighter colour, harder than the surrounding slate and about a couple of inches long.



Whether this is one of the marks above referred to, as examined by those gentlemen, I am unable to say.

A walk along Laxey Bay reveals several interesting features. At one point there are some immense boulders of a rock containing ironstone. These have evidently at some period been brought down from the high ground above, as they are not *in situ*. They are of slate, quartz, trap and pyrites, and in some parts there are "pockets" of oxide of iron of an ochreous nature.

At the Douglas end of the bay there are some large blocks of a peculiar convoluted nature. These rocks appear to form an intrusive mass of igneous character, and no doubt belong to the same family as the other "intrusions" in the island, viz., felsite or trap.

I brought a piece of a dyke from this spot, though not from the dyke just referred to, and a microscopic examination leads to the inference that it is a quartz porphyry. At any rate, it is a micro-quartz porphyry. The rock is composed of a felsitic base and quartz. The long axes of the quartz grains all point approximately in one direction, and the rock has a banded or schistose appearance. In the section one or two comparatively large crystals of quartz are present, and one quartz grain contains a negative crystal with a minute bubble. Very little felspar is present, and this is so decomposed that it would be impossible to distinguish it without the aid of the polarizer. A little magnetite is also present in flakes. The quartz is all separated by layers of the fleecy base, and the rock somewhat resembles fig. 72B., p. 290, in "Harker's Petrology." In one instance a large piece of quartz is found as an "eye," the other quartz and felsitic matter being arranged round it in a "flow" structure. The quartz does not contain many inclusions of a comparatively large size, but I noticed in one grain a "knee-shaped" crystal of rutile, and in many cases minute specks of dusty matter can be observed. I think there is little doubt that this rock was originally a "felsite," which has been altered by dynamic metamorphism, and had the schistose structure induced. The intense pressure to which it has been subjected has practically obliterated the characteristics of all the minerals, except the quartz, which by reason of its hardness has better withstood the pressure, converting the felspar probably into a mica, and, by the production of a felsitic base which separates the quartz, brought about the lamination. This characteristic can be well observed in a hand specimen, but much better in a thin section under the microscope.

In the village of Laxey a large quantity of lead ore and blende is obtained by the Great Laxey Mining Company. As the ore is brought to the surface it is seen to consist of slate, trap, quartz, galena, blende and copper ore. The galena and blende

only are worked for commercial purposes. By the kind permission of the Company, I was permitted to make an inspection of the surface works, where the extraction of the ores is carried on. The whole process, from beginning to end, is a most interesting sight, even the finest mud resolving itself into the separation of the different ores by means of their specific gravities.

From the lead ore, a quantity of silver is obtained, sometimes amounting to more than 100 ounces of silver to the ton of ore. A great amount of crystalline, opaque, milky quartz is also obtained from the mines, where it is found lining veins of the metal.

#### EXCURSION TO PORT SODERICK.

The formation here is the usual Silurian rock which is overlain by Glacial clay. The somewhat monotonous rocks are varied by several caves, which are, however, of no great dimensions. A brief examination of them suffices to show that they have been made by the mechanical action of the waves. Chemical agency has had nothing to do with their formation, as it has in the case of the large caves of Derbyshire. One portion of the Smugglers' Cave is evidently the result of the shifting of the rocks along a joint or fault.

At this spot there is a good beach of shingle and pebbles, and a search along such beaches generally results in the discovery of a few, at any rate, interesting pebbles. Here I found a large boulder of exceedingly tough dense rock of a light blue-grey colour, and so exceedingly hard and compact that it was difficult to knock off with the hammer a few specimens. It was crossed here and there by fine veins of quartz, and appeared from its macroscopic characteristics to be either a very close-grained felsite, similar to one I once obtained in the neighbourhood of Penmaenmawr, North Wales, or a quartzite. On examining a thin section under the microscope, the quartzite theory proved to be correct. The slide shows the rock to be made of quartz grains, closely compacted together. The interstices are filled with a "paste" of minute quartzose matter which in places forms comparatively large patches. The quartz crystals or grains are traversed by rows of fluid pores and minute inclusions, and fissured in places. The fissures generally are in one direction, and as a rule at right angles to the lines of inclusions. There is practically no felspar, but little turbid patches are seen which may be this mineral decomposed or altered by crushing; small flakes of magnetite are to be observed, and here and there portions of the rock are found which are unacted by the polarizer and seem almost opaque. These patches are, I believe, quartz "dust," and probably represent the ultimate result of metamorphism. Secondary quartz is not seen at all, and from the exceeding

density of the rock could not be expected. There is no idiomorphic quartz, the grains all being sub-angular to rounded, and polarizing in the usual vivid and brilliant colours, green, purple, blue, yellow, etc. One or two small "spongy" patches of a bright red colour are present, and are evidently garnets.

As I have made all my own slides of the Manx rocks I collected, I had the opportunity of comparing their hardness. Without doubt the quartzite just described was by far the hardest, and took the longest time to make. It was, however, a very good rock for the purpose, as, being so hard, and at the same time so dense and tough, it did not break during the process, but was capable of being ground very thin.

It would be a matter of interest to speculate on the origin of this boulder's position. I think there is little doubt that it is a "travelled" one. Very probably it was brought from Scotland during the Glacial period, as I am not aware of any of this rock having actually been found *in situ* on the Isle of Man. As I have already stated, the rocks at Port Soderick are covered by the glacial drift or "boulder clay," and very likely at one time this particular boulder was in the clay covering on the top of the cliffs. As these gradually wore away, the block of course eventually fell to the shore, and being so hard a material, is well able to resist the action of the waves and weather. I found it very near to the foot of the cliffs, which rather tends to support my theory.

#### EXCURSION TO PEEL

At Peel the strata at the southern end of the bay are the ordinary Silurian slates, but at the north end an exposure of a dark-red sandstone occurs, fairly dense of texture in some parts and coarse in others. It shows small lenticles of impure limestone and is accompanied by beds of conglomerate. The fact that the upper layers of this series contain a considerable percentage of lime would lead to the inference that the Carboniferous limestone had been above them, and therefore that the beds belonged to the Devonian series, or were the basal beds of the Carboniferous system.

Professor Boyd Dawkins has for certain stratigraphical reasons assigned them to the Permian series. Mr. G. W. Lamplugh, F.G.S., is not of this opinion, and I quote the following from his remarks in the "British Association Handbook to the Isle of Man for 1896": "On the whole the evidence seems to me to support the view of the earlier writers, that these rocks are not of later date than the beginning of the Carboniferous period. The strongest confirmation of this opinion has recently been furnished by the boring operations in search of coal in the north of the island. These borings have revealed the presence of a

series of sandstones and shales intercalated with the Carboniferous Limestone, and possessing, like the Peel sandstone, a high dip (from 40° to 50°), which are overlain by undoubted Permian and Triassic strata, lithologically unlike the Peel rocks, with low dips (rarely exceeding 5°)."

On the top of these rocks there is a thick deposit of glacial drift, and in one section I found a bed of clear, sharp, yellow sand, some two feet thick. It did not extend any great distance, soon thinned out, and eventually disappeared. It was fairly indurated, but is by no means a sandstone. It could, in fact, be easily scraped away with the fingernails. This bed of sand evidently represents an ancient sub-littoral deposit.

At the small fishing village of Peel there is another excellent pebble beach, and I was fortunate enough there to pick up two of more than ordinary interest, and having made slides of each of them, I will now describe their appearance under the microscope. The first I picked up was a piece of amygdaloidal basalt, the amygdules varying in size up to about a quarter of an inch in diameter, being filled with calcite. The rock is made up of a ground mass containing phenocrysts and the amygdules referred to. The ground mass consists of small lath-shaped crystals of feldspar, brown patches of augite, and small flakes and cubes of magnetite, the larger matter consisting of feldspar crystals, olivine, both fresh and slightly serpentinized, and a small section of opaque mineral which is probably titaniferous iron. Under the microscope the amygdules show double refraction very strongly, and cleavage too is markedly exhibited. They are in some cases netted over with thin streaks of greenish chlorite, and in others the chlorite occurs as small irregular-shaped patches. In some instances the calcite contains inclusions of magnetite, and it is noticeable that when the chlorite occurs as previously referred to, the calcite does not show the double refraction and cleavage nearly so strongly. These vesicles are also generally lined with a thin coating of fibrous chlorite.

Another pebble of which I made a slide was a red one, containing small crystals of flesh-coloured feldspar, the largest in the slide being a quarter of an inch long. The ground mass of this rock consists of a very fine base of microlites, etc., of a reddish colour, and cannot be identified as to its mineralogical constituents. Scattered throughout this base are large crystals of feldspar, flakes and cubes of magnetite, and also one or two sections of titaniferous iron. Amongst the large feldspar crystals twinning is very common, examples being observed on the "Albite" system, the "Pericline" system, and also "interpenetration." These crystals appear to have consolidated out of a molten magma. There are in addition to the feldspars just mentioned, sections of plagioclase (generally longitudinal)

These crystals are exceedingly corroded, both along the edges and at numerous small patches in the interior, and they evidently represent crystals which have been "erupted" along with the other volcanic matter which forms the rock, and by floating about in the molten magma have suffered this corrosion and abrasion. One or two of these crystals are seen to be bent in various ways, one comparatively long one being bent bow-shaped.

I think this bending must have taken place before the consolidation of the rock, as the crystals merely lie in the fine base mentioned, and are not in contact with any other crystals. The first-mentioned felspars contain numerous inclusions of an acicular nature. The microscopic evidence shows this pebble to belong to the Pyroclastic rocks.

(To be continued.)

## SERIAL POPULAR SCIENTIFIC LITERATURE.

THERE are now and again offered to the public works of a semi-scientific nature, to be issued in serial numbers, which, although they may not in the end belie the promises held out in the prospectus, are yet, from their often attractive appearance, liable to mislead young people—and older ones too—into an expenditure which is afterwards regretted. The prospectus of such a publication is probably as complete as can be expected from a purely business point of view, in that it states what the book is, but as we are not informed what the book is not, wrong inferences as to its character are inadvertently drawn, ultimately resulting in grave disappointment.

To make the case clear, let me give an example: Some time ago, I took in, in monthly parts, a work on a natural history subject, thinking it would be useful to my children. It ran to four volumes, and cost altogether, including binding, over two pounds ten shillings. No definite order was observed in the arrangement, and the comparison of allied species placed here or there, in one or other of the volumes indiscriminately, involved such inconvenience as to render the work practically almost useless.

The "Classified Index" was an afterthought, added at an extra charge, and would have been of some value had it been interspersed with the bare names of the excluded but often common species in their proper places, say in different type. The character of the "General Index" may be judged from what follows. Supposing the work, which I will not specify, to have been on Botany, none of the buttercups would occur under B, but one would be under C, thus, creeping buttercup, and another U, as "upright meadow buttercup." Or supposing this subject to have been Birds, and none of the owls under O, nor the wagtails under W. This is not a fancy picture—quite the contrary.

I took the volumes to pieces, arranged the items according to the classified index, added the excluded species in MS. on blank leaves inserted for the purpose, and copied from a useful little book, which cost a shilling, and re-paged the whole.

The work embraced descriptions and figures of about forty per cent of the British species,

which, to be impartial, was as much as was to be expected from the prospectus *if carefully read by an experienced person*. But mark the italics. Some of the figures were irremediably mixed, and this gave a great amount of trouble. The re-binding in the new form raised the cost to nearly three pounds in cash, to which is to be added the value of the labour of re-indexing, etc. The whole furnishes an example of how a too trustful public may be led by the "serial" system to waste sums of money on imperfect productions, which money otherwise expended would procure works of scientific value. It may be added that some common objects were omitted altogether.

Well may one ask, what would an admirer of field-flowers seeking information about, say, a buttercup with the sepals always reflexed, feel but disgust on taking down a fifty-shilling book and finding no reference whatever to the plant? This may not be the best illustration that can be given, but it will serve its purpose.

My advice to young people interested in any scientific subject is, when you see a serial publication advertised, put the monthly or weekly amount it will cost away in a box until you can get that, or possibly some better work, entire. In the meantime borrow from friends, or go to a public library, or obtain by any other possible means the information you need.

My remarks do not apply to really scientific works produced in parts, each one complete in itself. By taking such one becomes posted up-to-date in that portion of the subject treated. Publishers of the kind of literature here condemned may possibly urge that it creates a thirst for knowledge. Very well, but the game is not worth the candle when, as in the case in point, that same thirst may be created by such comprehensive little books as Atkinson's "Eggs," or Bagnall's or Fry's "Mosses," which will form safe guides and cost a shilling each. At half-a-crown to five shillings there are books to be had on almost any branch of natural science, which are at the same time interesting, instructive, and fairly comprehensive.

1, Underdale Villas,  
Shropshire.

W. HAMILTON.

## AN ORCADIAN RAMBLE.

BY ROBERT GODFREY.

STROMNESS was on holiday in honour of the Queen's birthday, and was being invaded by bicycles and "machines" laden with Kirkwall excursionists. Its narrow street, thronged with people from the country districts, all vieing with one another in the production of mirth and jollity, along with its harbour, densely crowded with herring-boats, and its fishing stations, like so many beehives in activity, all tended to make a marked impression of the town's importance upon a stranger arriving from the south. I, too, was on holiday, but having just come from a crowded city, I preferred to make acquaintanceship with the less frequented regions lying amongst the hills surrounding the town rather than mix with the jostling crowd. So, turning east, along the sea border, I soon passed beyond the town and reached open cultivated country, where the fields were divided from the highway by ditches and slight mounds only. The larks in unceasing song carolled overhead, and the constant screaming of the gulls around the fishing stations resembled in the distance a concert on the sea. The day was somewhat close, but clear, and as I trudged along over ground hitherto unvisited by me, I allowed my fancy to people at its pleasure the regions still ahead.

From the knowehead the view beyond was shut in by a barrier of hills running inland from Orphir, and separated from the nearer ground by an arm of the sea and the large loch of Stenness. Though cultivation still held sway, the gradual increase of pasture-land warned me of its coming preponderance. The Loch of Stenness has direct communication with the sea, and, along with the greater Loch Harray, from which it can hardly be said to be definitely separated, occupies an enormous area. It is a great haunt for wild fowl, and these lochs were the last known breeding-haunts of the wild swan in our islands.

The high road crosses the outlet of the loch by a low three-arched bridge, and brings us to the base of the Orphir Hills. The ground was covered with short grass and heather, beautified by the lousewort, but was in many parts completely bare, the turf having probably been stripped off for use. For a mile or two a rough road prevailed over moorland, with cultivated patches and crofts dotted here and there, and a steady walk of an hour and a half from the town brought me to the true hills with their wilder heather and their freedom from houses.

My only attendant was the never-failing peeweeep, and I had not yet seen any of the rarities I was on

the constant look-out for. Larks unceasingly sang, and occasionally a meadow pipit would flutter up from the ground, singing as it went. The heather was strong and eminently suited for wild life; one feature, however, informed me of its being more or less frequently traversed, namely, the peatbanks, that in many places broke its conformity. Traces of the red grouse were abundantly evident, yet I wandered up and down for half-an-hour before I disturbed a cock from some long heather. Golden plover had also by this time appeared, and were bleating on the hillslopes. The further I went the greater became the number of the peat-banks, and the occupation of the heather was as little likely as ever. A second cock grouse got up after a long interval, and again the normal silence prevailed.

On passing from heather to an extensive rush bed, I became hopeful of meeting with the short-eared owl, and carefully crossed and re-crossed the attractive area. Under the close state of the atmosphere, the persistent tramp became very tiresome, and was rendered more so by the absence of encouraging life. Starlings frequently passed with food in their bills, and peeweeeps were the only other species continually present. At length I heard a merlin call, without, however, having any indication of the haunt, as so many peat-diggers were all about the hill; so descending towards the valley where the peat-banks were of rare occurrence, I found myself in a region of fine wild heather and rush-clad ground. About two p.m. I came on castings containing the remains of field-voles, and also on characteristic bird-of-prey dung, and a little further on I had confirmation of the same. I perseveringly plodded on under this encouragement, being much pleased with the general aspect of the ground, where long-withered *Luzula* was interspersed with the rushes and the long heather, and in about a quarter of an hour I flushed a short-eared owl from a high heather patch. The bird issued with the conspicuous appearance of its race, and with measured, silent beat, flew along the top of the wild pasture to ensconce itself in the heather again. I carefully examined the spot from which the bird had risen, but found no indication of a nest. I lingered on in this advantageous ground, and zealously beat the rushes and long heather as I zigzagged about the hillside. Once I observed a fine plump field-vole run off across a small open space to the shelter of long heather and temporarily escape. Barely an hour had elapsed before I again roused the owl from a bed of rushes on soft mossy ground, and I

watched him sail over, with short intervals of flight, to the heather, where he alighted to gaze upon me. Only for a few moments, however, did he rest, then mounting again he sailed down into the valley, where, after a survey of the ground from a height, he alighted.

Turning up the hillside to vary my proceedings somewhat, I traversed an area of short thick heather, where the peaty soil was cracked in many parts. My supposition that starlings were breeding in these cracks was confirmed by the continual uproar of the birds and by my finding an egg-shell. The utter desolation of this region completely astonished me, though the extent and variety of the scenery displayed from various points on the crest somewhat atoned for this deficiency. The fine bracing wind about the hill-top was delightfully refreshing after my long tramp in the valley. I roused a pair of grouse that betrayed no signs of having young, and put up another cock and a single meadow pipit. I heard also a strange cry which I conjectured rightly enough—as I was able to prove a few days later—to come from the hen harrier, another species on which I was intent. No other life was about the hill-top, and my wild efforts to rouse harriers only resulted in a vacant stare from the grazing sheep. I afterwards learned that two nests—probably the produce of the same pair of harriers—had been taken there this season.

The advance of day compelling me to end my outward journey here, I again descended into the valley occupied by the owls, and at a brow of the hill I roused three peewees that began, in their customary manner, to dispute my rights of passage. Their uproar disturbed a short-eared owl from a bunch of rushes, and I watched this latter bird sometimes sail, sometimes fly, in his passage across the valley. Ere he had well alighted, a second owl rose nearer me, also from rushes, and flew off. I marked the spot, and carefully searched both quarters, but in vain. I did my utmost to find an owl's nest, but was compelled to proceed homewards amidst the constant derision of the peewees. Occasionally golden plovers were at hand, and once a pair of twites gambolled on a fence beside me, whilst the curlew was lustily calling from a croft near the bridge of Stenness, and a single blackbird was frequenting a clump of trees within the town.

16, Cumberland Street, Edinburgh.

THE TUNBRIDGE WELLS NATURAL HISTORY AND PHILOSOPHICAL SOCIETY is, as usual, full of enterprise. The Council have arranged a scientific reading circle to which the members each contribute sixpence monthly, and the Society contributes sixpence for each member joining. The Society thus directs the method and class of reading among its members, and gets the magazines for its library at half-price. The plan is found to work well.

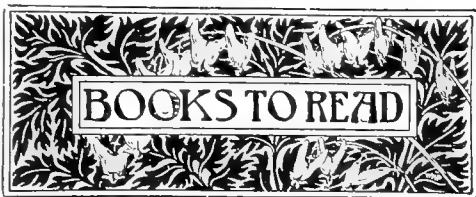

NOTICES BY JOHN T. CARRINGTON.

*An Illustrated Manual of British Birds.* By HOWARD SAUNDERS, F.L.S., F.Z.S., etc. (Second Edition). In 20 parts, each with about 40 pp. 8vo, and 20 illustrations. Part i. (London: Gurney and Jackson, November, 1897.) 1s. per part.

Ornithologists are to be congratulated that the demand for this, the best of all manuals of British birds, necessitates a new edition. Its issue shows that the students of our birds are numerous as ever, and that they appreciate Mr. Saunders' work. It is quite a marvel of cheapness, when we consider the excellence of the illustrations. The bulk of these are identical with those of Yarrell's large "History of British Birds," fourth edition. In the second edition of Saunders' Manual will be found several new blocks illustrating additions to our bird fauna; one of them we reproduce by permission of the publishers, representing Pallas's



PALLAS'S WILLOW-WARBLER.

willow-warbler, a rare bird recently noticed in Britain for the first time. Its occurrence was referred to in SCIENCE-GOSSIP for March (p. 284) in this year. As this manual of birds is so well known, it is hardly necessary to give a detailed description of the work; but it will be remembered that two pages only are devoted to each species of bird known to have occurred in our islands. The pages include the illustration and quite sufficient letterpress for first identification, with particulars of the range and previous records of each species. In fact it is quite surprising how much information is got into these two pages. Part i. opens the work with the Turdinæ; the first being our handsome mistle-thrush. Then follow the other thrushes, the wheatears, chats, redstarts, and the warblers are commenced. The issue of the second edition of Saunders' "Manual of British Birds" is an opportunity not to be neglected by lovers of the country and bird-life, all of whom should get this standard work as it appears.



WE understand that with the end of this year Mr. James Britten, F.L.S., ceases his connection, as editor, with "Nature Notes," the organ of the Selborne Society.

THE October number of the "Observatory" is illustrated by a portrait of Mr. W. F. Denning, whose name has been made famous by his work of so many years as practical observer of meteors, as well as in other branches of astronomy.

THE German Society of Men of Science and Physicians will hold its next meeting at Düsseldorf, in 1898, under the presidency of Professor Waldeyer, of Berlin. The secretaries will be Professor Mooren and Dr. Von Vichoff, of Düsseldorf.

WE regret to hear that in consequence of urgent medical advice, Sir William H. Flower, K.C.B., F.R.S., will not be able to preside, as arranged, at the next International Congress of Zoology, to be held at Cambridge in August, 1898. Sir John Lubbock, Bart., F.R.S., has been elected President in Sir William's place.

PROFESSOR OLIVER LODGE, F.R.S., will deliver the first of a course of six Christmas Lectures (specially adapted to young people) on "The Principles of the Electric Telegraph," at the Royal Institution, on December 28th. The remaining lectures will be given on December 30th, 1897, and January 1st, 4th, 6th and 8th, 1898.

ONE of the most remarkable effects produced by photography is nightly shown on the immense screen at the London Palace Theatre of Varieties, by the so-called "Biograph." It represents the appearance of the approaching landscape as seen from the front of a railway engine travelling at sixty miles an hour. The long series of these moving pictures is to be numbered among the wonders of modern science.

ABOUT half a century ago, there was taken a cream-coloured variety of the common marbled-white butterfly. The specimen has ever since remained in the collection of that well-known authority on the ichneumon flies, the Rev. T. A. Marshall, who has retired from the Church, and gone to live in Corsica. Mr. Marshall consequently placed his collections in the hands of Mr. Oliver Janson, of Great Russell Street, London, for sale. We hear the cream-coloured variety realised £21.

WE have received an illustrated reprint of a paper read before the British Archaeological Society, by Dr. Benjamin Winstone, upon "Some Primitive Ornamentation found on Prehistoric Pottery." The paper has scientific value from an ethnological point of view, as it compares certain types of ornament on the rough earthenware of prehistoric people of the continents of Europe and North America. There is actual identity in some of the patterns used on both sides of the Atlantic, and their origin forms the basis of Dr. Winstone's useful paper.

THE death is announced of the Hon. Ralph Abercromby, the eminent meteorologist and authority on cloud formations. He was born in 1842.

PROFESSOR GERALD LIPPMANN, Paris, has been awarded the principal medal of the Royal Photographic Society for his work in colour photography by the interference method.

THE valuable collection of vertebrata made by Mr. A. C. Savin from the forest bed, Norfolk, has been purchased by the trustees for the British Museum of Natural History.

THE Council of the Linnean Society of New South Wales, Sydney, is prepared to consider applications for the position of Macleary Bacteriologist. The salary is £500 a year.

WE have to announce the death of Dr. R. P. H. Hardenham, who, since October, 1859, has been Professor of Physiology at Breslau. He is the author of important works on experimental physiology, the most valuable being on "Secretion."

DUBLIN scientific circles will sadly miss the Rev. Samuel Houghton, M.D., F.R.S., who is also dead. Dr. Houghton was long connected with Trinity College, Dublin, and was for twenty years Secretary of the Royal Zoological Society of Ireland. He was born at Carlow in 1821.

CAPTAIN E. Y. WATSON, of the Commissariat Department, was unfortunately shot through the head in the Indian frontier fighting, and died on November 8th. Entomologists have lost in him one of their most promising workers. It was only quite recently that Captain Watson issued a revision of the Hesperidae, or skipper butterflies, of the world.

FROM M. E. Seriziat, 70 bis Quai Claude-Lorraine, Nancy, we have received a circular relating to "Lepidochromy," or the art of reproducing butterflies by the fixation of their colouring matter on paper. On the circular is a very beautiful example of the art, which, though not new, has been greatly perfected. The price is 20fr. per hundred pictures.

IT is with regret that we chronicle the sudden death, at the early age of 49 years, of Sir James Ramsay-Gibson-Maitland, Bart., F.L.S., F.Z.S., F.G.S., of Sauchie and Craigend, Stirling. Educated at St. Andrew's University and Sandhurst, he was an authority on pisciculture and a member of several fishery boards. His celebrated and successful fish-culture establishment at Howietown was the pioneer of scientific rearing and hybridization of the Salmonidae in this country.

THE Royal Society has awarded a Royal medal to Sir Archibald Geikie, F.R.S., for his many valuable and original researches in geology; also a Royal medal to Professor Charles Vernon Boys, F.R.S., on account of his studies of quartz fibres and investigation of their properties. The Copley medal goes to Professor Carl Gegenbaur, Foreign Member R.S., for his researches in comparative anatomy; the Rumford medal to Professor Philipp Lenard and to Professor W. Conrad Röntgen for investigation of the phenomena produced outside a highly exhausted vacuum tube through which electrical discharge is taking place; the Davy medal to Professor Henri Moissan, of Paris, the discoverer of the commercial method of producing acetylene gas as an illuminant; and the Darwin medal to Professor Giovanbattista Grassi, of Rome.



CONDUCTED BY FRANK C. DENNETT.

		Position at Noon.				
	Dec.	Rises. h.m.	Sets. h.m.	R.A. h.m.	Dec.	
Sun	...	7:49 a.m.	3:51 p.m.	16:40	22° 12' S.	
	13	...	3:49	17:24	23° 12'	
	23	...	3:52	18:9	23° 26'	
		Position at Noon.				
	Dec.	Rises. h.m.	Sets. h.m.	Age at Noon. d. h.m.		
Moon	3	5:49 p.m.	7:49 p.m.	1:47 a.m.	9 2:40	
	17	...	2:58 a.m.	10:42	19 2:40	
	23	...	1:38	3:14 p.m.	29 2:40	
		Position at Noon.				
	Dec.	S. Alt. h.m.	Semi Diameter.	R.A. h.m.	Dec.	
Mercury	3	0:49 p.m.	2" 5	17:40	25° 33' S.	
	13	...	2" 9	18:15	25° 18' S.	
	23	...	3" 6	19:35	22° 49' S.	
Venus	3	10:37 a.m.	5" 3	15:27	17° 39' S.	
	10	...	5" 2	16:19	20° 38' S.	
	23	...	5" 1	17:12	22° 37' S.	
Mars	13	11:27	1" 9	16:56	23° 5' S.	
Jupiter	13	7:1	1" 2	12:30	1° 54' S.	
Saturn	13	10:46	7" 0	16:15	19° 32' S.	
Uranus	13	10:24	1" 8	15:54	20° 7' S.	
Neptune	13	11:50 p.m.	1" 3	5:21	21° 46' N.	

MOON'S PHASES.

	Dec.	h.m.	Phase	Dec.	h.m.
1st Q.	1	7:15 a.m.	Full	9	4:54 a.m.
2nd Q.	17	4:22 a.m.	New	23	7:55 p.m.
3rd Q.	7	7:27 p.m.			

In apogee, December 8th, at 11 a.m., distant 252,600 miles; and in perigee on 23rd, at 3 a.m., distant 222,300 miles.

CONJUNCTIONS OF PLANETS WITH THE MOON:

Dec.	Planet	Time	Distance
18	Jupiter*	8 a.m.	6° 50' N.
22	Saturn*	5 a.m.	5° 47' N.
22	Venus*	1 p.m.	3° 11' N.
23	Mars*	5 a.m.	2° 26' N.
25	Mercury*	5 a.m.	0° 24' S.

\* Below English horizon. † Daylight.

OCCULTATION AND NEAR APPROACHES:

Dec.	Star	Magni- tude.	Dis- tance. h.m.	Angle from Vertex.	Re- appears. h.m.	Angle from Vertex.
7	6 Aurigæ	4.6	2:00 p.m.	75°	2:14 p.m.	325°
7	27 Tauri	3.8	2:47 p.m.	19°		Near approach.
19	69 Virginis	4.9	6:23 a.m.	223°		"

THE SUN has now been very quiescent for a few days. No dark spots were seen on disc for a few days near the end of October.

MERCURY is an evening star, attaining his greatest elongation east, 19° 59', at midnight on the 20th. About this time it sets an hour and a half after the sun, but is badly placed for observation.

VENUS is a morning star, in conjunction with Uranus at 2 p.m. on the 8th, Venus being 0' 47" N. She is in conjunction with Saturn at 8 p.m. on the 12th, and with Mars at 11 p.m. on the 30th, but her position is so low that she cannot be well observed.

MARS, SATURN and URANUS are too close to the sun for observation.

JUPITER travels along a short direct path just south-west of the celebrated binary star γ Virginis. It rises at 1:46 a.m. on the 1st, and seven minutes after midnight on the 31st.

NEPTUNE is in opposition at 8 p.m. on the 12th, and so is at his best for observation, appearing as an 8th-magnitude star south-west of the crab nebula, and a little west of ζ Tauri.

CERES, the minor planet, discovered on January 1st, 1801, shining as an 8th-magnitude star, comes into opposition on Christmas Day. Its position on the 1st is R.A. 6h. 45m. 9s., Dec. N. 25° 29' 13"; and on the 31st, R.A. 6h. 17m. 25s., Dec. N. 27° 58' 2", a retrograde path through Gemini into the confines of Auriga, passing about 11th north of ε Geminorum.

METEORS may be looked for specially on December 8th, 9th, 11th, 12th and 21st.

RED STARS IN POSITION DURING DECEMBER:

	R.A. h.m.	Dec.	Magnitude.	
01 Orion (B. 157)	4:47	14° 10' N.	5	Variable (?)
α "	4:59	0° 59' N.	6.5	Fine garnet
α "	5:50	7° 23' N.	1-14	Variable
β1 "	5:24	1° 20' S.	5	
B. 148 Aurigæ	6:28	38° 32' N.	6.3	Fine red
π "	5:53	46° 20' N. ±	5	
119 Tauri	5:26	18° 30' N. ±	5	

η Geminorum ... 6.8 22° 32' N. 4 { A few minutes s.p. and also n.p. are two other ruddy stars }  
 u " ... 6.15 22° 35' N. 3 { Orange }  
 B. 3. Add. 2 Canis Majoris ... 6.12 16° 46' S. 5.5

COMET a 1897 was discovered on October 16th by Mr. Perrine, of the Lick Observatory, about equal to an 8th-magnitude star, in Camelopardus, and having a short tail. Its path has carried it through the northern part of Cassiopea and Cepheus and now it is travelling through Draco. It should reach perihelion on December 8th, when its distance from the sun will be 1.36 the earth's distance=1.0. It was nearest to us on October 23rd, when its distance was 0.8. Most observers describe it as not exceeding 10th magnitude, and it is growing fainter.

THE LICK OBSERVATORY.—We regret to learn that Professor E. S. Holden has resigned the Directorate, his official relations ending with the present year. Professor J. M. Schaeberle will be acting director. Another unfortunate cause for regret is that the Crossley 36-inch silver-on-glass reflector does not render such good results as it should, the cause being found to lie in its focal length being too short.

THE YERKES OBSERVATORY is at last in working order.

THE GRESHAM LECTURES, November 2nd to 5th, proved of great interest; some of the slides shown were of exceptional interest, one being a grand painting of Jupiter by Mr. N. E. Green, and another was a magnificent photograph of the cluster ω Centauri taken at Arequipa.

PONS-WINNECKE'S COMET will probably be picked up before this is in the reader's hands. The comet was discovered in 1819 by Pons on June 12th. Winnecke in 1858 discovered that it had a period of five and a-half years, travelling in an elliptic orbit. It has been observed at each return since, except 1863 and 1880.

THE BRITISH ASTRONOMICAL ASSOCIATION will in future hold its meetings at Sion College, on the Thames Embankment.

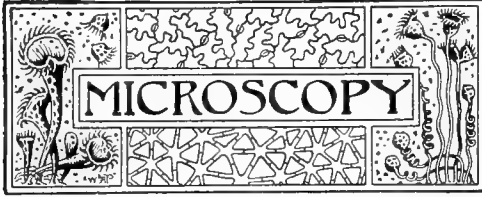

CONDUCTED BY J. H. COOKE, F.L.S., F.G.S.

To whom Notes, Articles and material relating to *Microscopy*, and intended for *SCIENCE-GOSSIP*, are, in the first instance, to be sent, addressed: "J. H. Cooke, Thorndale, Lincoln."

**MICROSCOPICAL STUDIES.**—Those of our readers who are in search of material for study during the forthcoming winter months, should write for the very detailed catalogue which has just been issued by A. Flatters, 16, Church Road, Longsight, Manchester. We have also received details from S. P. Bolton, 25, Balsall Heath Road, Birmingham, of the tubes of zoological and botanical objects that he issues weekly with notes and drawings.

**PROTOZOA OF SALT LAKES.**—Dr. P. Butschinsky, says the "Journal of Microscopy," has studied the Protozoa found in two salt lakes or limans, near Odessa. They are more abundant in the lake with less salinity, and they consist partly of freshwater and partly of marine species. The fauna of the two lakes is not the same, and in both cases very striking fluctuations occur.

**LIFE CYCLE OF COCCIDIA.**—In the "Comptes Rendus," M. Louis Léger gives the results of his researches on the life-history of various Coccidian parasites in Myriopods and Insects. He expresses the opinion that in Arthropods, the genus *Eimeria* does not represent a distinct parasite, but rather a stage in the life-cycle of a Coccidian. There seems to be no case known in which an Arthropod with Coccidia does not also include phases of an "Eimerian" cycle.

**ACETYLENE GAS IN PHOTOMICROGRAPHY.**—Acetylene gas as an illuminant in photomicrography, has been recommended by several workers during the past year. It is specially adapted to this work on account of its brilliancy and steadiness, and also for its portability, cheapness and safety in use. Mr. W. H. Walmsley renders the light monochromatic by means of a cobalt blue cell placed in the substage of the microscope, while Mr. T. J. Bray points out that many details otherwise unobtainable may be brought out by using a bichromate cell.

**A SIMPLE CONDENSER.**—A simple, inexpensive, and most effective condenser for use with high powers may be made by mounting one of the glass spheres which takes the place of a cork in lemonade bottles. We have had one in use for some time, and have found it most useful and efficient as an auxiliary to, or in place of, an Abbé condenser.

**TAXONOMIC VALUE OF SCALES OF LEPIDOPTERA.**—Mr. V. L. Kellogg discusses in the "pages of the "Kansas University Quarterly," the structure and office of the scales of Lepidoptera, and concludes that the most generalized scale is the small hair without specialized insertion; while the most specialized scale is the broadened toothed form with a pedicel and a cup-shaped insertion on

the surface of the wing. He applies the principle laid down by Comstock in his consideration of venation and shape of wing, and finds that his results coincide practically with the taxonomic conclusions reached by Professor Comstock.

**BRITISH MYCOLOGY DURING SIXTY YEARS.**—In the course of an address by Dr. M. C. Cooke before the Essex Field Club on the progress made in the study of British Mycology, attention was drawn to the vast strides that have of late years been made in this study in consequence of the increased attention that has been given to the subject by microscopists. In the year 1836 about 1,390 fungi were catalogued, but in 1896 acquaintance had been made with no less than 40,000. He alluded, too, to the discoveries of the brothers Tulasne concerning polymorphism, the work of Du Bary on fermentation, and Pringsheim's labours on the subject of symbiosis. These specialists, by confining their attentions each to one branch, have separated many hitherto mixed species of fungi by the exactness of their observations.

**MICROSCOPIC BUBBLES IN A SAPPHIRE.**—Movable bubbles are often seen in quartz and other crystals, but the appearance and disappearance of inclusions of this kind is a bit of nature's magic not often observed. An interesting experience with a cerulean blue sapphire is described by Mr. W. S. Beekman in "The Microscope." This was a beautiful gem of nine carats, but it had a flaw, and one cold morning he was astonished to see a moving bubble in this flaw as he picked up the stone. He hastened away to show the phenomenon to a friend. He could find no bubble for his friend, however, and at home he sought it again in vain, then tried to reason that it had in some way worked out of the stone. The search was resumed in the evening. Turning on the light, there again was the bubble, but it was falling to pieces, and in a few moments had disappeared. Its vanishing was a trick of temperature. Between 85° and 86° Fah.—which is the critical point of carbonic acid when under a pressure of 90 atmosphere—the bubble changed from a liquid to an invisible gas.

**DISSEMINATION OF DISEASE GERMS.**—A bacteriological examination of two New Testaments that have during the last sixty years been kissed by about 40,000 persons in the West Riding of Yorkshire, revealed seven species of micro-organisms. None of the germs were harmful, though they included various cocci, bacilli, moulds, yeasts and schizomycetes. Mr. F. W. Richardson, consulting chemist to the Bradford Corporation, has published an interesting report on the results of the examination.

**PHOTOMICROGRAPHY OF OPAQUE STEM SECTIONS.**—Mr. R. A. Robertson, M.A., B.Sc., gave a demonstration before the Botanical Society of Edinburgh, illustrating the methods he adopts in making photo-micrographs of recent and fossil stem sections. He has found that he can obtain all necessary histological details by directly photographing the surface with a micro-photographic apparatus. He planes down the surface of the wood with a steel plane. The only difficulty is the focussing, and this should be done first on a semi-opaque focussing plate, and finally on a focussing plate of clear glass. The illumination was by means of a magnesium ribbon fed through



a fixed tube and placed at an angle of about 45°, and a distance of about 10 or 12 inches from the surface to be photographed. Time, 40 seconds.

**NITRIFYING GERMS.**—In the course of a paper which was read at a recent meeting of the American Microscopical Society, Dr. M. A. Veeder refers to the necessity of purifying potable waters by the nitrifying process. It has been discovered recently that there is an antagonism between disease germs and what are known as nitrifying organisms, which produce nitrites and nitrates in the soil. Advantage has been taken of this to institute an intermittent process of filtration. Water containing the bacteria that it is desired to destroy is allowed to run into a filter composed of sand, and instead of being drawn off immediately is allowed to stand for a sufficient length of time to permit the destruction of the disease germs by their natural foes.

**THE ORANGE MITE.**—The greenhouse serves as a prolific hunting-ground for the microscopist, one of his most frequent acquaintances being the often abundant greenhouse mites, *Tetranychus telarius*. Now that the orange season is coming on it may be of interest to draw attention to a mite which infects the orange, and which is generically allied to its greenhouse relative. To assist those who may desire to seek for this little creature, which is known as *Tetranychus 6-maculatus*, the six-spotted mite of the orange, we now append some enlarged drawings of it, in which *a* represents the mite as seen from above, *b* the tarsus, *c* the rostrum and palpus, and *d* the tip of the palpus.

**PRACTICAL MICROSCOPY.**—In a lecture on this subject, delivered to the Chemists' Assistants' Association last month, Mr. Martin J. Cole gave many useful hints bearing on the technique of the cutting, staining and mounting of vegetable tissues. Having cut some sections of the stem of a plantain, he proceeded to mount some, unstained, in glycerine jelly, and some, double-stained with acid green and carmine, in Canada-balsam. The glycerine jelly was made by dissolving one ounce of gelatine in six ounces of water, adding four ounces of glycerine and a little cresote to preserve it.

**ALKALINE GLYCERINE.**—Although alkaline glycerine has been recommended for several purposes in micro-technique, it does not appear to be generally known how serviceable it is as an extemporary mountant in vegetable histology. Mr. W. Kirby, F.L.S., finds, says the "Pharmaceutical Journal," that the mixture best adapted for general use is composed of glycerine, two ounces, distilled water, one and a-half ounces, solution of potash, B.P., half-ounce. This combines the refringent property of the glycerine with the clearing action of the caustic potash, and it has the great advantage that the undesirable swelling action of the potash is considerably restrained.

**PLIOCENE DIATOMACEÆ.**—Dr. A. M. Edwards contributes a suggestive paper on "Casts of Bacillaria from the London Clay," to the "American Microscopical Journal." Neither the Eocene nor

the Pliocene diatoms in England have yet received the attention their importance merits. Dr. Edwards has given his attention to the matter, and has obtained from the London clay, fossil forms of *Coccinodiscus asteromphalus*, little discs covered with hexagonal markings and ring-like forms, which he suspects to be *Melosira sulcata*. The cast of a *Triceratium* in pyrite, and the silicious shell of *Stephanofyxis turris* were also discovered. This opens up an interesting field for investigation, for as Bacillaria are in the London Clay, it is evident that they should be traceable low down in the lower Eocene in geologic time.

**DRINKING-WATER AND THE MICROSCOPE.**—A few years ago chemical analysis was relied on to determine the fitness of water for drinking, and sufficient dilution of poisonous matter was regarded as making it harmless. This is changed. The problem is now looked upon as a biological rather than a chemical one, and the purity of water is judged by the character of the organisms it may contain, the fact being recognized that even the minutest possible quantity of foreign matter, if it be a disease germ, may be sufficient to start an epidemic. The danger consists not in the quantity

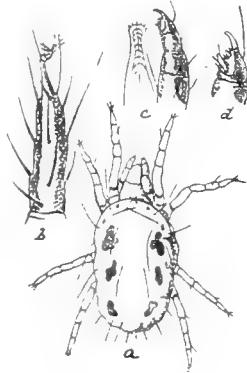

THE ORANGE MITE.  
*Tetranychus 6-maculatus*.

of such organisms, but in their power of growth under certain conditions. Typhoid fever, cholera, and certain forms of dysentery, are the chief diseases whose infection, it is generally admitted, can live in water; but Dr. M. A. Veeder, of Troy, states that during the last ten years he has maintained that the term "malaria," meaning bad air, is a misnomer, and that diseases of this class are very largely, if not exclusively, conveyed in water. Admitting this, drinking-water brings two classes of danger. Water taken from near human habitations may be contaminated with typhoid and diarrhoea germs from excreta, and that from virgin soil and undrained districts may bear the germs of malaria. In many localities safe water can only be had by purification, and for this an intermittent filtration—taking advantage of a recently discovered antagonism between what are known as nitrifying organisms and disease germs—may be better than sand filtration alone; the water being allowed to stand in the filter until the introduced nitrifying organisms have had time to destroy their foes.

**INTER-RELATIONS OF INSECTS AND YEASTS.**—The inter-relations of insects and yeast have, according to "Nature," been ably demonstrated by Dr. Amedeo Berlese. For the purposes of his investigations he used a large glass jar, well closed and carefully sterilized, inside which was hung a bunch of grapes that had also been sterilized by successive washing and immersion in carbon disulphide and boiling water. Connected by glass tubes with this jar were two other jars, one on each side, all of which were carefully sterilized, but so arranged that air could penetrate the system through plugs of sterilized cotton. Fourteen of these combinations were prepared, and in one was placed non-sterilized substances, such as bark of oak-tree, bark of vine, and soil. Similar substances were placed in the second, but these were first

sterilized, and in the connecting-tubes small vine branches, which were to serve as paths along which ants were to travel from the infected substances to the grapes. Some apparatus were left without insects. The result was, where insects had been introduced the grapes developed yeasts, moulds and bacteria; but where they had not been introduced the grapes remained unaffected. Ants, flies, etc., may therefore be considered as important agents in the diffusion of ferments.

**STIGEOCLONIUM.**—Mr. C. E. Britton, of 189, Beresford Street, Camberwell, gives some results of his investigations on the life-history of *Stigeoclonium*. He says: "The autumn and spring months seem very favourable for observing an important event in the life-history of this alga of freshwater, namely, increase by production of zoospores. More than once have I had the good fortune to be examining species of *Stigeoclonium* when these were preparing for asexual reproduction. The process of the liberation of the zoospores is interesting in the extreme, and the subsequent behaviour of these erratic bodies a matter to marvel at. The filaments and branches about to produce zoospores have their cell-walls very much swollen and exceedingly transparent, and the green cell contents are contracted in the centre. Each cell gives rise to a single zoospore, which, when ready to leave the parent cell, lies against the wall and protrudes a finger-like portion through a small aperture in the wall. The protruding portion, comparatively small at first, rapidly increases in size and becomes globular. At one time the zoospore resembles the shape of an hour-glass, a globular portion outside being connected by a narrow band to a globular portion within the cell-wall. The external part of the zoospore still increases in size, whilst that within the cell decreases, and the few remaining chlorophyll bodies can be seen to pass quickly through the opening in the cell-wall and along the connecting-band, into the free part of the zoospore, after which the remainder of the zoospore is withdrawn from the cell and the whole assumes an ovoid shape. After being momentarily quiescent, the zoospore rolls over a few times in the direction of its longer axis, and then darts off on a brief period of activity. Sometimes the last part of the zoospore seems to have a difficulty in passing through the aperture in the cell-wall, and the free portion sways to and fro, liberating the latter part, and then the zoospore swims away with a narrow tail-like part trailing from the rear. By careful focussing, the anterior part of the zoospore is seen to be colourless, and a red 'eye-spot' is discernible. When a little iodine solution is introduced beneath the cover-glass, the zoospores are killed and stain a deep brown, and the propelling organs can be seen as four colourless spreading cilia about as long as the zoospore."

**ANSWERS TO CORRESPONDENTS:**—*J. B.* (Cardiff): We know nothing of his preparations. He issues monthly or quarterly printed notes. Jersey would be sufficient.—*S. P. B.* (Birmingham): Thanks for information re "Microscopical Studies." We would suggest the "Exchange" column for the set you speak of.—*H. P. and others*: Please see paragraph under "Microscopical Studies" in this issue.—*C. F. G.* (Kirton): Many thanks for article. It was too late for last issue. Always glad to hear from you.—*Rev. H. W. Lett*: We have submitted the object sent to several able microscopists; but they are not prepared to say more than it is not a vegetable growth.



**JOSEPH WILLIAM DUNNING.**—Had there never been a Mr. Dunning, it is possible the present position of the Entomological Society of London might have been very different. To him the Society owes not only its incorporation, but, perhaps, its existence. It was not always that the Entomological Society flourished as successfully as now. There have been in its history critical periods, when doubts existed as to the possibility of weathering the bad times, and when large deficits met the annual audits. Few men have been more staunch than was Mr. Dunning to that Society; for during most of its career, whenever the pinch of necessity came, there appeared also its benefactor with open purse-strings, ever ready to give it a fresh start. Perhaps it will never be known how much he spent in its aid, but his gifts have been termed munificent, for his help was extended largely to the library, as well as to its executive expenses. He was but a boy, barely sixteen years old, when he first joined the Entomological Society, having been born in 1833. His father was a solicitor of Leeds, in Yorkshire, and he the only son. As a youth Dunning spent much time on the collection of butterflies and moths, and though he retained his love for them he never became a scientific entomologist in the modern sense. His tastes rather ran to the academic side of his favourite science than otherwise. We are not aware that Dunning ever wrote much on entomology, his chief claims resting upon a most useful work which sadly needs re-editing and bringing up-to-date. We refer to "An Accentuated List of the British Lepidoptera," which was published, by John Van Voorst in 1858; its issue was largely due to Dunning's compilation and financial aid. That work contained also hints on the derivation of the scientific names then applied to the British butterflies and moths. The Entomological Societies of Oxford and Cambridge were responsible for the accuracy of the "Accentuated List"; the respective councils for the year being for Oxford, H. Adair Pickard, M. A. Matthews, E. Stowe, C. E. Kemp, J. O. Westwood, and J. T. D. Llewelyn; for Cambridge, Chas. Cardale Babington, F. Barlow, T. Brown, J. W. Dunning, and A. F. Sealy. Alas, how few of them remain with us. When young Dunning left school he went to Cambridge and became a Fellow of Trinity College in 1853. In 1861 he was called to the Bar, and at one time enjoyed an extensive chamber practice as an authority on the law of rights of way and highways, as well as a conveyancer and equity draughtsman. His career was unfortunately cut short in 1892 by a stroke of paralysis from which he never really recovered. Mr. Dunning was the Secretary of the Entomological Society from 1862 to 1871, then repeatedly a Vice-President, and President in 1883 and 1884. His life's contribution to science was rather that of a rich man than of a worker. Such contributions are equally useful to those of the savants; for without such support few scientific bodies could hold together in their earlier periods of existence. Mr. Dunning died suddenly on October 15th last.—J.T.C.



**POPULAR COLLECTING-GROUNDS.**—It is proposed to commence a series of articles in *SCIENCE-GOSSIP* upon the opportunities offered to visitors for studying nature near some of the chief holiday resorts in Britain. The object of these articles will be to direct visitors, who know something of one or other of the subjects, how and where to find material for study in the larger branches of natural history—the words being used in their widest sense, as embracing the earth and its inhabitants. The first locality selected is the Isle of Man, one of the most popular of all the playgrounds. From its central position, it is accessible from all parts of the kingdom, and one of the most prolific in every branch of natural science. The series of articles commences this month with the first half of a description of the rocks of the island, by Mr. Frederick J. Gray. Other writers who are familiar with the Isle of Man are invited to contribute articles on the fossils; the plants; the birds; the insects; the shells; the seaweeds; marine zoology, etc. The plan of the articles should be to give a short general account of the subject treated with reference to the island; then a series of excursions to the more important collecting-grounds, with some particulars of them, and what may be found there.—*ED. S.-G.*

**BOTANICAL PLATES.**—A correspondent writes: "I have some botanical plates about 8½ inches by 5½ inches, signed at the left 'E. R. Lankester, del.' and on the right 'J. E. Sowerby, Sc.' Could any one tell me to what work these belong, as the names have in some cases been removed and I wish to correct this?"

**PHENOLOGICAL NOTES.**—On October 18th, in walking from Falmer to Offam, near Lewes, the following were seen in flower: poppy (*Papaver rhæas*), field scabious (*Knautia arvensis*), common avens (*Geum urbanum*), yarrow (*Achillea millefolium*), saw-wort (*Serratula tinctoria*), sheep's scabious (*Jasione montana*), ragwort (*Senecio jacobea*), white campion (*Lychnis vespertina*), white dead-nettle (*Lamium album*), yellow bedstraw (*Galium verum*), speedwell (*Veronica buxbaumii*), sow-thistle (*Sonchus oleraceus*), bell flower (*Campanula trachelium*) red campion (*Lychnis diurna*). A large dragon-fly was also seen during the same walk.—*E. A. Martin.*

**EFFECT OF ADDER'S BITE.**—On October 17th, while handling a couple of recently caught adders (*Vipera vera*), my attention was drawn away from the reptiles, and I received a bite on the third finger of the right hand. I sucked the wound and had a string tied very tightly round the finger, but as the latter became very black I loosened and after a few minutes removed the ligature. After walking for half an hour I began to feel ill, my body became cramped and pained, breathing became difficult, and I could only speak in a thin wheeze. Violent vomiting then set in and continued at short intervals for about four hours, being aggravated both by a small quantity of whisky and by some sal-volatile. The hand and arm had meanwhile become much swollen. I felt very prostrate and

was unable to lie in a comfortable position. About five hours after the bite I began to recover rapidly and was able to get up and go for a walk within two days. The hand and arm subsided to their normal size within four days, leaving me perfectly well again. The viper which bit me is a rather large one, being about twenty inches long and in fat condition. I was bitten on the left hand by an adder in August last, but only one fang entered the flesh, and the sole effects were a swollen hand and arm, lasting three days. On that occasion I rubbed salad oil into the wound and drank some, but as a medical friend ridiculed the idea that this treatment was beneficial, and called it an antiquated remedy, I did not adopt it in the case of the second bite. Gilbert White recommends salad oil as a "sovereign remedy for the bite of a viper."—*Hugh Bromley, 52, Elsham Road, Kensington, W.*

**HABITS OF SPARROWS.**—In considering the onslaught that has recently been made upon the sparrow, it is as well perhaps to remember that sparrows, whatever harm they may do to crops, are also insect-devourers. This may be proved in the summer months to one's satisfaction by walking through St. James's Park, where they will be seen hawking after insects. Gilbert White speaks, in one of his letters, of the sparrows as great dust-washers, and all lovers of birds have doubtless watched the operation of dust-washing with great interest. This habit is not confined, however, to sparrows. In June last, as I was resting on a green bank just outside Herne Bay, a skylark swooped suddenly down to the road near me, and went diligently through the process, being watched by a party of my friends.—*Edward A. Martin.*

**RARE FUNGI NEAR CROYDON.**—The pine woods at Addington, south-east of Croydon, have produced a wealth of fungi this year. Among others obtained during a ramble, on November 7th, were two specially deserving of remark. The first is the large and handsome *Sparassia crispa*, which, growing on the ground in a great mass nearly a foot in diameter, looks not at all unlike a fine cauliflower. The spore-bearing surface, or hymenium, is spread over a series of whitish fleshy branches, spreading from a short thick stem which is quite hidden by their profuse ramifications. This fungus is known to be a delicious esculent. It is the only species of its genus, and is closely allied to the genus *Clavaria*. The second rarity is *Tremellodon gelatinosum*, a small and inconspicuous, but really beautiful, member of the *Hydnei*, and formerly included in the genus *Hydnum*, from which it differs in the wholly gelatinous and tremulous nature of its substance. Three or four specimens were found growing on the flat surface of a pine-stump. The largest measured nearly two inches across its irregular pileus, which is fan-shaped, and from above has the appearance of a cat's paw, with its brown velvety-looking cuticle. Underneath the cap are arranged the numerous bluish-white spines or teeth on which the hymenium is spread, all directed towards the stem, which is short and lateral. At the end of nine days the plant still remains fresh in the tin in which I have been keeping it. Stevenson gives the time of its occurrence as from September to October ("British Fungi Hymenomycetes," vol. ii., p. 247). I may add that this fungus is recorded by Berkeley from Weybridge, while *Sparassia crispa* I have taken also at Oxshott.—*F. P. Perks, 41, St. Martin's Lane, W.C.*

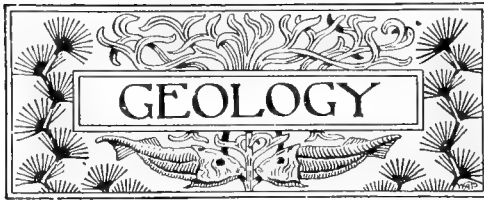

CONDUCTED BY EDWARD A. MARTIN, F.G.S.

To whom all Notes, Articles and material relating to Geology, and intended for SCIENCE-GOSSIP, are, in the first instance, to be addressed at 69, Bensham Manor Road, Thornton Heath.

**PLEISTOCENE BEDS AT CARSHALTON AND HENDON.**—An interesting discovery was announced at the meeting of the Geological Society on November 3rd, that what is apparently a Pleistocene bed has been discovered at Carshalton, in Surrey, during the making of a new sewer. The bed lies beneath about fourteen feet of pebbly sand, and is, itself, a carbonaceous loam of between three and four feet thick. It stands higher than the existing alluvium, and probably represents the work of the Wandle when it was a river of greater influence. One of the many streams which feed the Wandle has its origin in Carshalton Park. The bed has been examined by Mr. W. W. Watts, F.G.S. A description was furnished by Mr. E. T. Newton, F.R.S., of some animal remains found therein. These consist of the skull of *Rhinoceros antiquitatis*, which measured 31 inches long, in which the teeth were lacking, and some leg-bones, together with horse-remains and a portion of an elephant's tusk. These interesting objects have been lodged in the Jermyn Street Museum. In the discussion which followed, Mr. W. Whitaker, F.G.S., added some interesting remarks in regard to the mapping of the district for the geological survey. The President (Dr. Hicks, F.R.S.) pointed out that a similar bed had been discovered at Hendon, N.W., during sewerage operations, containing animal remains.

**INTERSTRATIFIED QUARTZITE.**—Mr. H. B. Woodward exhibited at the Geological Society, on November 3rd, a block of quartzite from Criccieth, North Wales, in which a layer of clay had become interstratified, and had been peculiarly altered and contorted by heat and pressure. Mr. Lamplugh, F.G.S., considered it as a crushed conglomerate.

**SUSSEX PLEISTOCENE CLIFF-FORMATION.**—Visitors to the South Coast, by travelling from Brighton to Rottingdean in the sea-car of the recently constructed over-sea railway, can obtain a very satisfactory and comprehensive view of the cliffs east of Brighton. This is specially so in regard to the remnants of the formerly more extensive Brighton Cliff Formation. From the distance of about 200 yards seaward the Chalk is seen at the base of the cliff, intersected obliquely and horizontally by tabular flint. At ten feet from the present beach is seen the raised beach of completely rounded stones, and of about eight feet in thickness at some places. During the last two years there have been numerous falls of the Chalk and the face of the cliff has retired considerably. The result conveys the impression that we are approaching the northern limit of the formation. For whereas when I described the cliffs in 1892 there were between three and four feet of sand beneath one and a-half feet of beach, now the sand is represented by but a trace, and the raised beach has increased in thickness to no less than eight feet.

The large rounded stones of the ancient beach rest in fact almost upon the Chalk. The "Elephant Bed" above is seen to be distinctly stratified, and as the top of the cliff is reached the flints contained in the loam become more jagged and less rounded, until one might almost imagine that "Flint Jack" himself had even thus early been at work. On the existing beach are strewn boulders of sandstone of all sizes, which are in marked contrast to the flints, their companions in the raised beach and in the loam. One large sub-angular, ruddy-brown sandstone boulder, which had an exposed surface at least two feet long, was seen *in situ* half-way up the cliff, whilst at the foot was a mass measuring five feet in its longest dimensions, others of smaller measurements being plentiful. These must have been transported from beyond the escarpment of the South Downs to their present positions.

**FOSSIL CLUB-MOSSES.**—All our Carboniferous club-mosses, of which we know the fruits, were heterosporous, that is, had spores of two kinds, and thus were related rather to *Selaginella* than to *Lycopodium*. In the *Selaginellaceae* the female "macrospores" produced the archegonia, and the male "microspores," the antheridia, this arrangement, according to Carruthers, foreshadowing amongst the cryptogams the embryo-sac and pollen-grain of the phanerogams.

**CORRELATION OF ANCIENT FAUNAS.**—Mr. Herbert Spencer pointed out many years ago that the causes which have changed faunas in different parts of the world have been local and not universal causes, and that, therefore, it would be contrary to all possibility to expect to find even in identical geological ages a similarity in animal and vegetable life in widely-scattered deposits. Similarity in the *facies* of two faunas, as evidence of synchronism, was therefore an assumption contrary to all probability. Huxley followed on in 1862 by saying that even absolute identity of fossils is no proof of the synchrony of deposits, while absolute diversity is no proof of difference of date. Yet although theoretically these views are almost universally adopted by geologists, one constantly hears, at the present day, of attempts to correlate widely-existent formations by means of their fossil remains. In fact, such a means of correlation is, one would be led to think, almost the only reliable means available. Yet how great is the danger of doing so has been pointed out over and over again by distinguished geologists.

**AN AMERICAN MEDITERRANEAN.**—A study of North American geology reveals the fact that in mid-Tertiary times the Gulf of Mexico extended northward beyond its present boundaries, filling up the depression east of the Rocky Mountains as far as the junction of the Ohio with the Mississippi. For a long time previous to this, there is reason to believe that it extended so much farther northward as to allow of communication between the Gulf of Mexico and the Arctic Ocean, but this northward extension disappeared only within comparatively recent geological times. In this mid-American sea were laid down successively representatives of our geological systems, the sea-board varying extensively from age to age, now extending and now retiring, until in Tertiary times the great inland sea had disappeared, leaving mighty tributaries of a mighty river to drain the area over which the sea at one time held so great a sway.



CONTRIBUTED BY FLORA WINSTONE.

LA NATURE (Paris, October 23rd, 1897). M. Henri de Parville continues his very interesting series of articles on "The Memory of Fishes." In this number he goes so far as to claim the faculty of memory for caterpillars and mollusca, founding his remarks on communications received from various correspondents who have tried experiments with these animals. He also gives a third example of memory in fishes, received by him from M. Pierre Mègnin. He says that the carp in the fountains at Fontainebleau if fed with hard crusts of bread will not eat it, but leave it in the water under the charge of one of their number. After watching it from time to time this fish will, at the end of about fifteen minutes, when the bread is soft, swim to his companions, and on informing them of the fact, they all swim back and devour the softened bread. M. Mègnin has tried this experiment several times. The Baron de Watteville has an illustrated article on "Pipes," giving a history and description of the various forms of pipes which have been in use from the early days up to the present. "A New Cybium," *Cybium proosti*, is described, with illustrations by M. Emile Demenge. The bones of this fish were found by M. Alphonse Proost, Director-General of Agriculture, in the Eocene sea, in the midst of the "marnes bruxelliennes" which flow into the Brabant. (October 30th.) Dr. Ph. Glangeaud writes on "The *Pithecanthropus erectus*," found by M. Eug. Dubois in the Island of Java, some time ago. Dr. Glangeaud gives illustrations of the manner in which the skull of the extinct animal can be built up from the fragments discovered. He also gives the reasons for believing this animal to be the missing link between apes and mankind, showing how much more closely the bones resemble those of a monkey than of a man. We fear much evidence is still wanting in proof. M. de Napaillac writes on "Gold in the Arctic Regions," giving a full illustrated account of the road to Klondyke. M. de Mareschal describes and shows some peculiar results obtained by means of photographs of the human perspiration. The illustrations shown are from clichés of M. Ch. Brandt's photographs. (November 6th) M. Paul Mègnin contributes an article on "Wild Dogs," describing and illustrating the wild dog of Abyssinia, a specimen of which was lately presented to the Jardin d'Acclimatation, Paris. The writer points out that the popular notion that all dogs are descendants of wolves, jackals, or even foxes, is entirely wrong. Recent writers on zoology, more especially M. Pierre Mègnin in the first volume of his book on "The Dog and its Races," have shown that the dog is descended from four types which were originally wild dogs. The specimen at the Jardin d'Acclimatation has the same dentation as a domesticated dog, but it has only four toes on its feet. It bears some resemblance to a hyena. M. J. Poisson gives an account of the method of grafting tomatoes on potatoes, used by the sons of M. Ch. Ballet.

ROYAL METEOROLOGICAL SOCIETY.—The opening meeting of the session was held on November 17th, at the Institution of Civil Engineers, Mr. E. Mawley, F.R.H.S., President, in the chair. Mr. R. H. Curtis gave the results of a comparison between the sunshine records obtained simultaneously from a Campbell-Stokes Burning Recorder and from a Jordan Photographic Recorder. The Campbell-Stokes recorder consists of a sphere of glass four inches in diameter supported in a metal zodiacal frame. A card being inserted in one of the grooves according to the season of the year, the sun, when shining, burns away or chars the surface at the points on which its image successively falls, and so gives a record of the duration of bright sunshine. The Jordan recorder consists of a cylindrical box, on the inside of which is placed a sheet of sensitive cyanotype paper. The sunlight, which is admitted into the box by two small apertures, acts on the paper, and travelling over it by reason of the earth's rotation, leaves a distinct trace of chemical action. In an improved pattern two semi-cylindrical boxes are used, one to contain the morning and the other the afternoon record. The Campbell-Stokes instrument gives a record of sun heat, and the Jordan instrument a record of sun light, and whilst it is probably true that as a rule the burning and chemical effects vary directly with the brightness of the sun's rays, yet it by no means follows that the conditions which will produce the most active chemical action must necessarily and always be those most favourable for burning. It has been the opinion of most observers that the photographic instruments yield a larger record than those of the burning type. In order to set the matter at rest, the Council of the Royal Meteorological Society determined to institute a comparison between the Campbell-Stokes and the Jordan recorders which should thoroughly test the capabilities of the two instruments and at the same time afford reliable data for determining how far the records yielded by the one may be accepted for comparison with those obtained from the other. These simultaneous observations were carried out by Mr. E. T. Dowson, at Geldeston, near Beccles, and extended over a period of twelve months. The records were sent to Mr. Curtis for tabulation, who gave the results of his examination in this paper. After describing the methods adopted for the measurement of the records, Mr. Curtis drew the following conclusions from the figures: (1) In the case of the Campbell-Stokes instrument the records are capable of being measured with a very fair degree of accuracy. (2) The records of the Jordan instrument afford room for much greater difference of opinion as to what ought to be tabulated, and consequently measurements of the Jordan curves are open to considerably more doubt than are measurements of the Campbell-Stokes curves. (3) When the whole of the photographic trace which can be distinctly seen, but including portions of it which are decidedly faint, has been carefully measured,

the amount will approximate sufficiently to that of the Campbell-Stokes instrument to allow of records obtained from both forms of instrument being compared *inter se*. From an examination of the records at other stations, it appears that on some occasions the instruments have begun to record within thirteen minutes after sunrise, and have continued up to ten minutes before sunset. Mr. Curtis concluded his paper by calling attention to various defects in the adjustment and working of the instruments, and pointed out how these might be overcome. After the paper had been read, an interesting discussion ensued as to the merits of the respective sunshine recorders.—*William Marriott, Assistant Secretary.*

SOUTH LONDON ENTOMOLOGICAL AND NATURAL HISTORY SOCIETY.—October 28th, 1897.—Mr. R. Adkin, F.E.S., President, in the chair. Mr. H. B. Browne, B.A., Hammersmith, was elected a member. Mr. Montgomery exhibited a long bred series of *Cidaria truncata (russata)*. The female parent was var. *centum-notata*, but none of those bred were of that form; also a bred series of *Acidalia dimidiata* from July ova, and stated that some half-a-dozen larvae apparently intended to hibernate; specimens of *Apamea ophiogramma*, bred from ova, and a *Cidaria corylata*, which emerged at the end of September. Mr. Newman, large first and second broods of *Arctia carya*, the former from larvae taken round Darenth, the latter from ova, and reared in a greenhouse. Considerable variation was shown, but only one of the more extreme dark forms and one of the yellow hind wings forms occurred. A small, very pale specimen was the most unusual form. *Argynnis paphia* with white patches, *A. adippe*, showing increase of dark markings, both from Goodwood; *Epinephele janera*, two specimens with the usual fulvous colour quite white, from Singleton, and *Smerinthus populi* bred of a very pink tinge. Mr. Tutt, on behalf of Dr. Riding and Mr. Bacot, the long series of the much-debated *Tephrosia*, together with crosses, hybrids, mongrels, etc., and made remarks upon the results of their experiments; on behalf of Mr. Merrin, a long series of varieties of *Melitaea aurinia*, and a specimen of *Aglais urticae*, having an incipient silvery mark on the undersides of the fore-wings; on behalf of Mr. Horne, an almost completely black variety of *Nemeophila plantaginis*; and on behalf of Mr. Griffith, a series of *Tephrosia* taken in the Bristol woods. Mr. Moore, a specimen of *Enodia portlandica* from North America, and said that it did not seem right to place this species and *E. hyperanthus* in the same genus; and a specimen of *Locusta viridissima*, with its eggs, from Chambery. Mr. Perks, specimens of the fungus *Thelephora lacinata* from Shirley. Mr. Adkin, varieties of *Argynnis selene* from Sutherlandshire, much duller than usual, and with marginal spots large and pale. Mr. Merrifield, a very large number of specimens bred under extremes of temperature, to illustrate his resumé, entitled, "Recent Examples of the Effect on Lepidoptera of Extreme Temperatures applied in the Pupal Stage."—Nov. 11th. Mr. R. Adkin, F.E.S., President, in the chair. Mr. Tutt exhibited a number of *Psyche* cases, taken by Messrs. Edwards, Tunaley and himself, in the forest of Fontainebleau, including *Psyche unicolor (graminella)*, *P. opacella*, *Epichnopteryx bombycella* and *Fumea nitidella (intermediella)*. Mr. Filer, a long series of mottled forms of *Nonagria arundinis (typhae)*, bred by Mr. Dennis and himself, from Surrey. Mr. Bishop, specimens of *Aglais (Vanessa) urticae*, one having very large spots and the other almost var. *ichnusa*,

both from Epping; *Melanippe fluctuata*, having a broad marginal band dark, the inner area light, with the exception of a black costal blotch on the fore-wings; and various varieties of *Fidonia atomaria*. Mr. Moore, the following Orthoptera from La Grand Chartreuse: *Stetheophyma variegata*, *Decticus verrucivorus*, *Psophus stridulus*, *Stenobothrus geniculatus*, *S. declivus*, *Ædipoda fasciatum* and others, and contributed interesting notes and observations. Mr. Perks, the rare fungus *Tremellodon gelatinosa*, from Addington Woods. Mr. Adkin, bred specimens of a black variety of *Odonoptera bidentata*, from Westmorland. Mr. Bishop reported that on November 7th he found a female sawfly bush on the North Downs in flower. Mr. Tutt then read an exhaustive Paper, entitled "The Drinking Habits of Butterflies and Moths," and a long discussion ensued.—*Hy. J. Turner, Hon. Report. Sec.*

NORTH LONDON NATURAL HISTORY SOCIETY.—Thursday, October 7th, 1897.—Pocket-Box exhibition. Mr. Battley exhibited *Hesperia lineola* and pupa-case from Gravesend, *Eremobia ochroleuca* from Eynesford, and other lepidoptera; also, on behalf of Mr. Rose, xanthic vars. of *Epinephele janira* and *Coenonympha pamphilus* from Eynesford, etc. Mr. Prout, *Agrophia trabcalis*, *Acidalia rubiginata*, *Dianthoecia irregularis*, and *Lithostege griseata*, from Tuddenham, in June, etc. Mr. Austin, a case of birds' eggs. Mr. C. Nicholson, some of the so-called jumping beans of Mexico, which are the seeds of one of the Euphorbiaceae, each containing a larva of *Carpocapsa saltitans*, a species allied to *C. pomonana* (the codlin moth). He also showed a specimen of the moth, bred by Mr. Wheeler, from one of the seeds, and the pupa-case and seed from which it emerged. It is not known exactly how the movement of the seeds is produced, but it is supposed that the larva springs about inside in a manner similar to that of a cheese-maggot, though the object of such a proceeding seems dubious. Mr. Nicholson also exhibited numerous scarce lepidoptera. Microscopes were exhibited by several members.—*Lawrence J. Tremayne, Hon. Sec.*

CITY OF LONDON ENTOMOLOGICAL AND NATURAL HISTORY SOCIETY.—Tuesday, October 19th, 1897.—Mr. J. W. Tutt, F.E.S., President, in the chair. Exhibits: Mr. Clark, dark vars. of *Dianthoecia conspersa* from Shetland and the mainland. Mr. May showed the underside of a female *Polygonmatia corydon*, with long confluent spots on upper wings, taken near Guildford, also a pair of *Heliothis peltigera* bred from larvae, two pairs of *Tapinostola geminipuncta* bred from pupae, and an *Agrotis exclamationis* with confluent stigma, all from Sandown this year. Mr. Tutt exhibited a black variety of *Nemeophila plantaginis* from Aberdeen. Mr. Bate read a paper entitled "The Ideal Local Natural History Society." In the discussion which followed, Mr. Clark strongly advocated improvement in the Society's cabinet, which ought, he said, to be made so complete as to render assistance to all members in naming their doubtful specimens.—*Lawrence J. Tremayne, Hon. Sec.*

CAMBRIDGE ENTOMOLOGICAL AND NATURAL HISTORY SOCIETY.—At a meeting held on October 29th, Mr. Farren exhibited *Hesperia lineola* from Burwell Fen, *Polia xanthomista* from the Isle of Man, and other lepidoptera. Mr. Lepoy exhibited specimens of some salt-water insects from South Wales; a beetle (*Oxylebius legolesius*) and its larva; a rat-tailed maggot resembling *Eristalis*, and two *Chironomid* larvae with the pupa and fly of one of them. They live in small salt pools on the face of a cliff, about ten feet above high tide, the saltness



of the water varying greatly from time to time. Dr. Sharp exhibited a small portion of the collection of *Carabidae*, made by Mr. Perkins, in the Hawaiian Islands, for a committee of the Royal Society and British Association. They included 700 or 800 specimens, representing five or six very closely allied forms. He stated that these forms were so extremely closely allied that it was reasonable to consider them as modifications of one species that had undergone change in connection with difference of locality. Some of the forms, however, were from the same island, so that it was not possible to consider the geographical isolation as the immediate or sole cause of the distinctions.

**NOTTINGHAM NATURALISTS' SOCIETY.**—At the meeting of November 9th, the Rev. A. Thornley, M.A., F.E.S., the recently elected President of the Society, gave his inaugural address. Among other points, Mr. Thornley said: As a member of the natural history societies of the neighbouring counties of Notts and Lincolnshire, he had from the quiet vantage ground of his parish watched the working of both, and had arrived, wrongly or rightly, at some very definite conclusions about the work and functions of a local natural history society. In these days they saw such an expansion of scientific teaching, that what with University College courses and public lectures of various kinds, unusual opportunities for study had been provided for nearly all, in the great towns at least. So that the question might well arise—What was the ordinary status of a natural history society like theirs in the educational system of their own day? Was there any need for such an institution? He proposed in his succeeding remarks to answer that question. Having dealt with the definition and scope of such a society, Mr. Thornley submitted that its functions should embrace at least instruction, stimulation, field work, and protection. With respect to the first element, he remarked that an admirable series of lectures promoted by the Nottingham Society during the winter months had been most profitable in the way of instruction to the members, and must have done a great deal towards the removal of that narrowness which almost invariably followed too exclusive work in any one branch of natural history. Their own society, whilst it did well to supplement its ordinary work in that way, would make a mistake, he contended, if it did not do a great deal more than that. The fact that a number of students of nature were brought together, to know one another, to exchange views and ideas, to compare results, to view specimens, and to give mutual aid, supplied at once, without any further argument, a magnificent *raison d'être* for the existence of such societies as theirs. Mr. Thornley commented upon the importance of field work, asserting that to work out its geology, its botany, its living forms, was their first duty and one which was within the capacity of all their members. That branch of work required doing still more thoroughly over all the counties of Great Britain. He dwelt upon the subject of entomology, believing it to be one of the most neglected, and spoke of the need for further organization. It seemed to him, from his standpoint of an entomologist, that the county of Nottingham provided what might be considered as three separate areas for work, and he would be interested to ascertain whether geologists and botanists would agree with him. These distinct areas were Sherwood Forest, the Trent Valley from Newark to Gainsborough, and the Nottingham district.

## NOTICES TO CORRESPONDENTS.

**TO CORRESPONDENTS AND EXCHANGERS.**—SCIENCE-GOSSIP is published on the 25th of each month. All notes or other communications should reach us not later than the 18th of the month for insertion in the following number. No communications can be inserted or noticed without full name and address of writer. Notices of changes of address admitted free.

**NOTICE.**—Contributors are requested to strictly observe the following rules. All contributions must be clearly written on one side of the paper only. Words intended to be printed in *italics* should be marked under with a single line. Generic names must be given in full, excepting where used immediately before. Capitals may only be used for generic, and not specific names. Scientific names and names of places to be written in round hand.

THE Editor is not responsible for unused MSS., neither can he undertake to return them, unless accompanied with stamps for return postage.

**SUBSCRIPTIONS.**—Subscriptions to SCIENCE-GOSSIP, at the rate of 6s. 6d. for twelve months (including postage), should be remitted to the Proprietors, 86, St. Martin's Lane, London, W.C.

THE Editor will be pleased to answer questions and name specimens through the Correspondence column of the magazine. Specimens, in good condition, of not more than three species to be sent at one time, *carriage paid*. Duplicates only to be sent, which will not be returned. The specimens must have identifying numbers attached, together with locality, date and particulars of capture.

ALL editorial communications, books or instruments for review, specimens for identification, etc., to be addressed to JOHN T. CARRINGTON, 1, Northumberland Avenue, London, W.C.

### CORRESPONDENCE.

J. K. (Stoke Newington).—Adams' new edition of his manual of "British Land and Freshwater Shells" will be found the most modern and handy work of reference for studying British extra-marine mollusca.

### EXCHANGES.

**NOTICE.**—Exchanges extending to thirty words (including name and address) admitted free, but additional words must be prepaid at the rate of threepence for every seven words or less.

**DUPLICATES.**—About 700 species of neatly carded and correctly named British Coleoptera; desiderata, local Lepidoptera, Coleoptera, or stamps.—A. Ford, Rosemount, Hannington Road, Boscombe, Bournemouth.

**WANTED,** offers for the whole of SCIENCE-GOSSIP, 1865 to 1897; first 28 volumes in publisher's cover, remainder unbound.—G. P. Bonny, 30, Wellington Road, Stoke Newington, London, N.

**BIRDS' EGGS OF NORMANDY.**—M. Paul Noël, Directeur du Laboratoire d'Entomologie agricole de la Seine-Inf., à Rouen, désirerait échanger une collection très complète des œufs des oiseaux de Normandie, 2,500 spécimens, tous bien déterminés.

"KNOWLEDGE," 1890-91, 2 vols. bound in one, good as new. What offers?—F. Mayor, 2, St. Alban's Villas, Heaton Chapel, Stockport.

**BOOKS FOR SALE.**—Newman's "Butterflies and Moths" Cox's "Handbook of Coleoptera," 2 vols.; "Entomologist," vols. 15, 16, 17, 21, 22, bound. What offers?—Charles Ince, 76, Godolphin Road, Shepherd's Bush.

### NOTICES OF SOCIETIES.

**LONDON ANATEUR SCIENTIFIC SOCIETY.**

Dec. 17.—Meeting, one week earlier than usual on account of Christmas.

**NORTH LONDON NATURAL HISTORY SOCIETY.**

Dec. 2.—"Insectivorous Plants." R. W. Robbins.

" 16.—General Business Meeting—Election of Officers for 1893.

**LAMBETH FIELD CLUB AND SCIENTIFIC SOCIETY.**

Dec. 6.—"Fossils, and the ways in which they are found preserved." Dr. H. F. Parsons.

" 11.—"Visit to Natural History Museum, Shell Gallery.

" 13.—"Photographic Demonstration." C. J. Stokes.

**LURBOCK FIELD CLUB.**

Dec. 12.—"Totteridge, Shenley and Ridge.

**NORTH KENT NATURAL HISTORY AND SCIENTIFIC SOCIETY.**

Dec. 1.—"Origin and Physical Description of the Earth and Moon." W. Turner.

" 15.—"Mounting Slides." Wm. Scott.

" 29.—"The Microscope." Jno. Stacey.

1893.

Jan. 12.—"Bacteria." C. J. Brooks.

" 26.—"Entomology." H. Broughton.

Feb. 9.—"Leaves: their Structure and Use." J. W. Cooper.

" 23.—"Aquaria and Uncommon Pets." Jno. Potter.

Mar. 9.—"Conchology." E. Dennis.

" 21.—"British Birds' Eggs and Nests." D. Miller.

April 6.—"Lepidoptera." S. J. B. Pinn.

## HULL SCIENTIFIC AND FIELD NATURALISTS' CLUB.

- Dec. 8.—"Davos, the Engadine and the Italian Lakes." R. H. Philip.
1898.  
Jan. 5.—"The Fishes of the River Hull." H. M. Foster.  
" 19.—"The formation of an English Village," lantern illustrations. J. R. Boyle, F.S.A.  
Feb. 2.—"Breeding-Haunts of British Birds," lantern views. T. Audas, L.D.S.  
" 16.—"An Early Doctrine of Evolution." Rev. C. A. Hall.  
Mar. 2.—"The Natural History of Goole Moor." Thos. Bunker.  
" 16.—"Spectroscopic Astronomy," lantern illustrations. Rev. H. P. Slade, M.B.A.A.  
" 30.—"The Marine Fauna of the Yorkshire Coast," lantern views. F. W. Fierke, M.C.S.  
The Meetings held at 72, Prospect Street, alternate Wednesdays, 8 p.m.—*T. Sheppard, Hon. Sec., 78, Sherburn Street, Hull.*

## CARLISLE ENTOMOLOGICAL AND NATURAL HISTORY SOCIETY.

- Dec. 6.—"The Butterflies of Cumberland, with Notes on their Distribution." G. B. Roulledge, F.E.S.  
" 20.—"Winter Visitors to Burgh Marsh." M. C. Dixon.
1898.  
Jan. 3.—"Review of 1897"  
" 17.—Annual Exhibition of Specimens.  
Feb. 7.—"Coleoptera." F. H. Dav.  
" 21.—"Preliminary Man." J. Murray.  
Mar. 7.—"Lepidoptera taken at light in Carlisle." J. E. Thwates.  
" 21.—"Observations on Bird life." B. Johnston.  
*F. H. Day, Hon. Sec., 6, Currock Terrace, Carlisle.*

## PRESTON SCIENTIFIC SOCIETY.

- Dec. 1.—"The Chemistry of Food," illustrated by experiments. J. B. Coppock, F.C.S.  
" 15.—"Conversazione." Guild Hall. Presidential Address, Dr. Collinson.
1898.  
Jan. 19.—"Bees." Rev. J. Browne, S.J.  
April 6.—"Methods of Fishing and Fish Culture on our Coasts." R. L. Ascroft (Member of the Lancashire Sea Fisheries Committee).  
" 20.—"Biography of a Fern." W. Clitheroe.  
\* Illustrated by oxy-hydrogen lantern.  
Lecture Hall, Cross Street. Winckley Square, 8 p.m.  
*W. Hy. Heathcote, F.L.S., Secretary, 47, Frenchwood Street.*

## TUNBRIDGE WELLS NATURAL HISTORY SOCIETY.

- Dec. 3.—"Sicily and its Architecture." W. Law Bros.  
" 11.—"20,000 feet above the Sea." Mr. Whympier, at 3 p.m.  
" 17.—"Zoology of Egypt." E. H. Myddelton-Gavey, M.R.C.S.
1898.  
Jan. 14.—"Lepidoptera." H. Shepherd Walwyn.  
" 28.—"How men did business 4,000 years ago."—H. S. Robertson, B.A., B.Sc.  
Feb. 11.—"Specimen and Microscopical Meeting. Short Paper, "An Oak Tree Problem." R. Russell Hutchinson.  
" 25.—"Krakatoa, the great Volcano." Sir Robert Ball, F.R.S., LL.D.  
" 26.—"A Universe in motion." Sir Robert Ball, at 3 p.m.  
Mar. 11.—"Torpedo Warfare." Fleet Engineer T. J. Haddy, R.N.  
" 25.—"Honeycombing and other forms of weathering of stone." Illustrated by lantern. Geo. Abbott, M.R.C.S.  
April 8.—"Problems in Plant Life." Benj. Lomax, F.L.S.  
May 6.—Annual Meeting.  
Ordinary Meetings in the Literary Society's Library, 32, Pantiles, on Friday evenings at 8.—*Miss Cooke, Hon. Sec., 19, Guildford Road.*

## WARRINGTON FIELD CLUB.

- Dec. 3.—"Sixty Years' Science." A. J. Jolley.
1898.  
Jan. 21.—"The Geological Action of Volcanoes, with special reference to North Wales." W. H. Woodcock.  
Feb. 4.—Short Papers: "Algae," Rev. H. Brierley. "Physiology of Respiration," lecture, Dr. Bowden.  
" 18.—"Plant Structure: the Stem and the Flower." A. T. Gillanders.  
March 4.—"Frog Spawns." L. Greening, F.L.S., M.R.I.A.  
" 18.—Entomological Evening and Annual Meeting. 7.30 p.m., in the Museum Lecture Room.

*Alf. J. Jolley, Hon. Sec.*

## METROPOLITAN SCIENTIFIC SOCIETIES.

The following is a list of societies in the London district devoted to natural science, with hours and places of meeting. They may be visited with introduction from a Fellow, Member, or Secretary. Will secretaries send additions or corrections.

ANTHROPOLOGICAL INSTITUTE OF GREAT BRITAIN, 3, Hanover Square. Second and fourth Tuesdays at 8.30 p.m., November to June.

CITY OF LONDON COLLEGE SCIENCE SOCIETY, White Street, Moorfields, E.C. Last Wednesday in each month, October to May, 7.30 p.m.

CITY OF LONDON ENTOMOLOGICAL AND NATURAL HISTORY SOCIETY, London Institution, Finsbury Circus. First and third Tuesdays, 7.30 p.m.

CONCHOLOGICAL SOCIETY, LONDON BRANCH, St. Peter's Rectory, Walworth. Irregular meetings. Rev. J. W. Horsley, President, will answer enquiries.

CROYDON MICROSCOPICAL AND NATURAL HISTORY CLUB, Public Hall. Third Tuesdays, October to May, 8 p.m.

DULWICH SCIENTIFIC AND LITERARY ASSOCIATION. Fortnightly lectures Lordship Lane Hall, second and fourth Mondays, 8.15 p.m., from October, for winter season.

EALING NATURAL SCIENCE AND MICROSCOPICAL SOCIETY, Victoria Hall, Ealing. Second and last Saturdays, October to May, 8 p.m.

ENTOMOLOGICAL SOCIETY, II, Chandos Street, Cavendish Square. First Wednesday, October to June (except January). Third Wednesday, January, February, March and November, 8 p.m.

GEOLOGISTS' ASSOCIATION, University College, Gower Street. First Friday, 8 p.m., November to July.

GEOLOGICAL SOCIETY OF LONDON, Burlington House, Piccadilly. First and third Wednesdays, 8 p.m., November to June.

LAMBETH FIELD CLUB AND SCIENTIFIC SOCIETY, St. Mary Newington Schools, Newing on Butts, S.E. First Mondays all the year and third Mondays in winter, 8 p.m.

LINNEAN SOCIETY OF LONDON, Burlington House, Piccadilly. First and third Thursdays at 8 p.m., November to June.

LONDON AMATEUR SCIENTIFIC SOCIETY, Memorial Hall, Farringdon Street, E.C. Fourth Friday in each month, October to May, 7.30 p.m.

LUBBOCK FIELD CLUB. Working Men's College, Great Ormond Street, Bloomsbury, W.C. Excursions second Sundays, Meetings following Mondays, 8 p.m.

MALACOLOGICAL SOCIETY OF LONDON, meets in Linnean Society's Rooms, Burlington House. Second Friday each month, November to June, 8 p.m.

MINERALOGICAL SOCIETY. Meets in rooms of Geological Society, February 4th, April 14th, June 23rd, November 17th, 8 p.m.

NONPAREIL ENTOMOLOGICAL AND NATURAL HISTORY SOCIETY, 99, Mansfield Street, Kingsland Road, N.E. First and third Thursdays, 8 p.m.

NORTH KENT NATURAL HISTORY AND SCIENTIFIC SOCIETY, St. John's Schools, Wellington Street, Woolwich. Alternate Wednesdays, 7.30 p.m.

NORTH LONDON NATURAL HISTORY SOCIETY, North-East London Institution, Hackney Downs Station. Second and fourth Thursdays, 7.45 p.m.

QUEKETT MICROSCOPICAL CLUB, 20, Hanover Square. First and third Fridays, 8 p.m.

ROYAL BOTANIC SOCIETY OF LONDON, Regent's Park. Second and fourth Saturdays at 3.45 p.m.

ROYAL HORTICULTURAL SOCIETY, 117, Victoria Street, S.W. Second and fourth Tuesdays, except December to February; 2 p.m. on show days, which vary.

ROYAL METEOROLOGICAL SOCIETY, 22, Great George Street, Westminster. 3rd Wednesday, November to June, 8 p.m.

ROYAL MICROSCOPICAL SOCIETY, 20, Hanover Square. Third Wednesdays, October to June, 8 p.m.

SELBORNE SOCIETY, 20, Hanover Square. No winter meetings.

SIDCUP LITERARY AND SCIENTIFIC SOCIETY, Public Hall, Sidcup. First and third Tuesdays, October to May, 8 p.m.

SOUTH LONDON ENTOMOLOGICAL AND NATURAL HISTORY SOCIETY, Hibernia Chambers, London Bridge, S.E. Second and fourth Thursdays, 8 p.m.

SUTTON SCIENTIFIC AND LITERARY SOCIETY, Public Hall Chambers. Second and fourth Tuesdays, 8 p.m.

WEST KENT NATURAL HISTORY, MICROSCOPICAL AND PHOTOGRAPHIC SOCIETY. Meets in School for Sons of Missionaries, Blackheath, third Wednesday, in December, fourth Wednesdays in October, November, January, February, March, April, May, 8 p.m.

ZOOLOGICAL SOCIETY OF LONDON, 3, Hanover Square. First and third Tuesdays, 8.30 p.m., November to August.



## WOOKEY HOLE CAVE.

BY C. P. A. DE L. PEREIRA.

THIS cave is situated near a village in the neighbourhood of Wells, Somerset, and consists mainly of three large, lofty chambers connected by short passages. The roof, sides and part of the floor of these chambers are covered with a very beautiful stalactitic incrustation, which assumes most fantastic shapes. The cave is mentioned by Clemens of Alexandria in the second century, and again by William of Worcester in the fifteenth century. It was supposed to be the habitation of a witch who was afterwards turned into stone by the "lernerd wigtz

water, settling in the depressions, ultimately finds its way through interstices in the limestone, and, following the dip of the rock, in course of time wears it away, thus forming the cavern. This work is aided by acids present in the water and by the friction of pebbles. In the locality the funnel-shaped depressions on the Mendips are called "swallets."

The height of the two principal chambers of the cave varies from forty to sixty feet. The third chamber, in which the river disappears under a naturally-formed archway, measures no more than



THE "WITCH" IN WOOKEY HOLE CAVE.

of Glaston." This "witch" is shown in the illustration given above. Near the River Axe, which flows through the cavern, human remains were discovered by Dr. Buckland and by others.

Connected with the main chambers of the cave are many winding passages. These branch off in every direction, and any person wandering unthinkingly into their inmost recesses must consider himself fortunate if he easily discovers his way back. In many parts of the cave one comes across huge boulders—some weighing several tons—piled one upon another, and appearing as if a mere touch would cause them to fall.

It is believed that the formation of the cave is due to the flatness of the Mendips, which allows little opportunity for the rains to drain off. The

twenty feet in height. The photographing of the cave was attended with great difficulty, many weeks being employed in obtaining a successful result. It is fair, however, to state that the photographs were made by amateur photographers from among my own friends. The illuminant used was magnesium ribbon. The effect is best shown in our third illustration, which appears on the next page.

Near this cave is another, called the Hyænas' Den, from its having been once inhabited by these animals. It was discovered in 1859, and was excavated by the well-known geologist, Professor W. Boyd Dawkins. The bones of many now extinct animals were found: among them those of the cave-lion, cave-bear, woolly rhinoceros,

reindeer, Irish elk, horse and hyæna. Flint implements, flakes, and cores were also discovered. The excavation revealed three distinct layers of earth. The lowest contained bones and teeth of the hyæna, and of animals which formed its prey. Next came remains of the lion, bear and sabre-toothed tiger; the uppermost layer contained flint flakes, implements, and charcoal. Some of the bones discovered exhibit tooth marks—those of the hyæna. The hyæna, it may be noted, hunted at night in packs, driving the animals on which it preyed over precipices by howling behind them.

The writer of this article, with his brother, lately discovered another small "den," in which were found many bones and teeth of the before-mentioned animals, especially those of the rhinoceros. It is supposed that the latter was larger than the present living species, and that its body was covered with wool. The horse was much smaller than at present; on the other hand, the bear, lion and sabre-toothed tiger appear to have been larger than their modern representatives.

The human inhabitants of these caves are believed to have been Iberians: short, bullet-headed, with dark hair and eyes. Their food consisted of fish and the flesh of the deer and other animals. They clothed themselves with the skins of the animals they killed. Their implements were flint spears and arrow-heads fixed to wooden shafts, and saws, knives and scrapers, also of flint. The scrapers

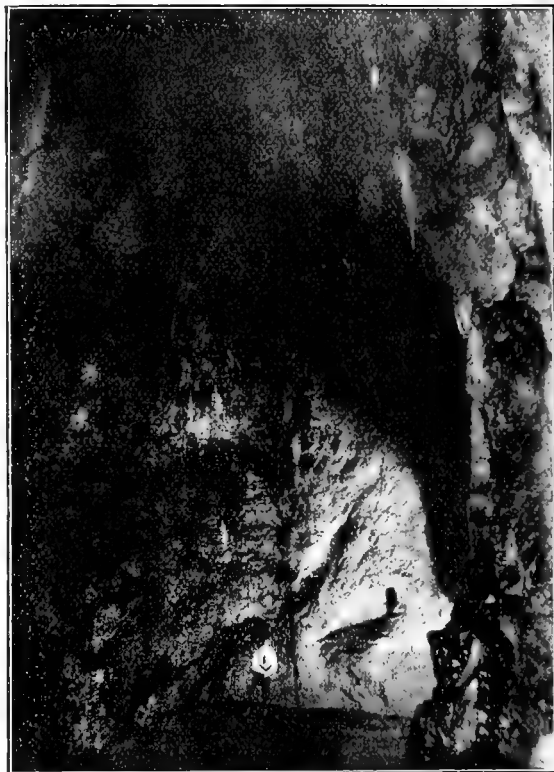

THE DISAPPEARING RIVER.

were employed for removing the hair from the skins which constituted their clothing; needles of bone have also been discovered. The Iberians' method of writing was by means of a flint on a bone

with a flat surface, such as a rib-bone, on which they scratched a rude picture, which easily conveyed their meaning to the person for whom it was intended. A considerable number of these interesting picture-writings have been found, many of which are at present in the British Museum, in France, and in private collections. — *Rosecourt, Theale, Weston-super-Mare.*

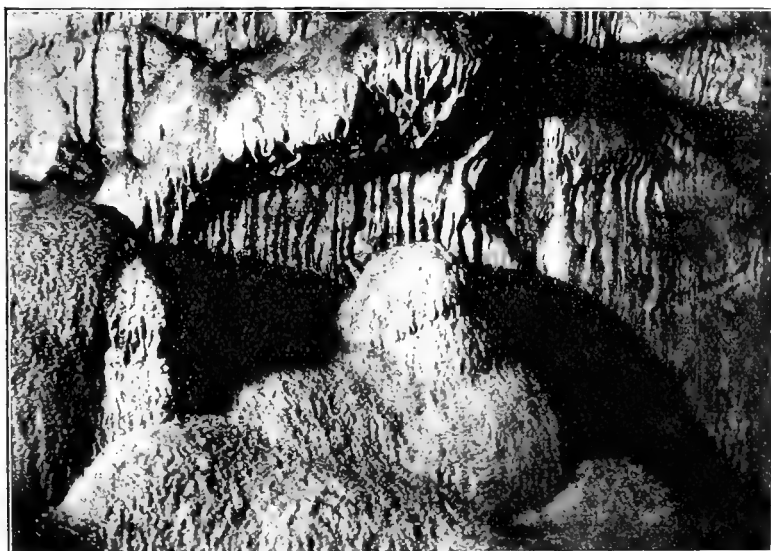

PART OF THE CAVE.

## THE ROCKS OF THE ISLE OF MAN.

BY FRED. J. GRAY.

*(Continued from page 203.)*

## EXCURSION TO CASTLETOWN.

THIS town is without doubt the best place on the island to make as a centre for a day's or a few days' excursion. On leaving the town and walking along the shore of Castletown Bay in the direction of Langness Point, the glacial drift is skirted, and in one part in the neighbourhood of Sandwick a stretch of low sand dunes is found. On passing by these and continuing in the same direction, the first thing of interest seen is a small exposure of diorite of a dark-green colour, and exceedingly decomposed on the surface. This occurs on the shore of the bay, and, as stated, is of quite small extent, looking in fact merely like a very huge boulder. It stands a few feet higher than the ordinary ground surface at that point. On making an examination of a thin slice of this rock under the microscope, the principal minerals contained therein are found to be hornblende and plagioclase. The hornblende is perfectly idiomorphic, exhibits strong polarization colours in dark-red and green, and shows very well the cleavage angle of  $124^{\circ} 30'$ . About half of a very large crystal comes just on the edge of the section, and being in that position, the other half is unfortunately not there. The plagioclase is very much decomposed, exhibits cleavage well, and also examples of twinning on the albite system. A very plentiful mineral in this rock is epidote, which occurs in comparatively large patches of a light-green colour, seen without the polarizer. This mineral fills a great deal of the interstitial space between the idiomorphic crystals, but does not itself occur with sharply-defined boundaries, and it is often seen lining fissures in the other minerals. Zoisite of a light greyish-brown colour also occurs in this rock. Quartz is very sparingly scattered throughout the rock, and what there is of it is in all probability a decomposition product. One or two small cross sections and a few needles of apatite are seen, and also a few patches and minute cubes of pyrites.

Continuing on our way, some thin beds of limestone of a very dark grey colour are met with, being the outskirts of the Carboniferous series previously mentioned. A little further on we see some very interesting beds of conglomerate, varying in thickness from one to three feet, which underlie the limestone beds just mentioned, and which are in fact the Carboniferous base beds. These dip gently towards the opposite side of the bay, and are very much worn and eroded by the

action of the sea waves. The general appearance of these beds is very striking. They are of a deep red colour and exceedingly rough, the matrix being generally softer than the pebbles contained therein, having been decomposed and worn away, leaving the pebbly matter standing out in all directions, and so giving the beds and low cliffs an exceedingly rugged appearance. The pebbles in this conglomerate are of varying sizes up to six or seven inches long, and are of different colours, most, however, with the exception of the quartz and quartzite, being of a sombre grey hue. The quartz is of the massive white variety, and the quartzite a very fine grained pinkish rock.

Many pebbles, likewise composed of the fine kind of this conglomerate, are found strewing the beach in this locality, and will themselves in all probability go to form a similar deposit in ages to come. Thus we can see how geology repeats itself, and is always throwing down for the purpose of building something else up.

On arriving at a disused copper mine, the contorted clay schist first makes its appearance. This is here of a blue colour, somewhat dull, the strata being inclined very steeply, say sixty degrees, in the opposite direction to the conglomerate, which they underlie. The beds of schist are contorted in many ways, and show well what enormous causes must have been at work to bring about such results. A further walk along this interesting little peninsula and there are found some splendid examples of arches made by the wearing action of the waves. They are fine instances of the destructive agency of the sea, where the cliffs are composed of two different rocks, namely, a thick deposit of conglomerate on the top and the contorted schist underneath. In this case a tongue of cliff runs out into the sea; the top of this tongue is a deposit of conglomerate about ten feet thick, the under part to ground level being blue schist inclined at a very high angle. At a short distance from the junction of this particular piece of cliff with the remainder, it has been cut right through from the ground surface to the underside of the conglomerate bed, and forms an opening approximately square, about eight feet high, and ten feet wide. This has very probably been brought about by the battery of shingle on each side, which has gradually worn the cliff through, the operation being no doubt aided by the soft nature and high angle of the schist.

At the extreme end of the Langness Point the schist assumes a brilliant claret colour, and occasionally a sage green. Here it is intersected

with dykes of felsite and quartz porphyry, and veins of quartz and copper ore. The copper is found in sufficiently large quantities for the ore to be worked for commercial purposes.

Here again the combination of schist and conglomerate makes the scenery grand, rugged, and fantastic. The cliffs are not very high, and gradually run down to the water, but at their highest point they are covered by caps of conglomerate. These are carved into all manner of strange and weird figures, and altogether the sight is very startling. The respective colours at this point are different to the arch previously mentioned, the schist being a brilliant claret colour, and the conglomerate of a greenish hue. On breaking some of the pebbles of these "caps," I found quartz, quartzite, slate, trap, felsite, schist, etc., the felsitic ones having a strong resemblance to the dykes of the vicinity. This shows that some of the material, at any rate, for the manufacture of this "pudding-stone" has been taken from the rocks of the locality. These caps were composed, besides pebbles, of angular pieces of slate, schist, etc., the rock partaking both of the character of a conglomerate and a breccia. This very probably denotes the top of these beds, as a certain amount of the angular material had not time to become rounded, and formed into pebbles before the deposit was rendered inaccessible to the action of the waves. This occurred, no doubt, owing to a depression of the land just previous to the time when the Carboniferous beds were laid down.

I was not able anywhere to find a felsite dyke intruding on the conglomerate beds, and think it very probable that those dykes were formed prior to the deposition of these beds. Assuming that the pebbles previously mentioned were portions of the dykes in question, then their origin must have been subsequent to the time of the Lower Silurian slates into which they intrude, and prior to the formation of the Carboniferous system.

I made a microscopic examination of a thin slice of felsite from one of these dykes, and found the rock consists principally of quartz and felsitic matter. It is of a greyish hue and very sombre in appearance. The quartz occurs as small grains or patches, but never idiomorphic. What little feldspar can be recognized by the aid of the polarizer is very much decomposed and turbid. The felsitic ground mass is of the usual "fleecy" character, and of a grey-brown colour. The quartz is generally clear and glassy; it contains inclusions, and is somewhat fissured. The slide bears a great resemblance to the quartz porphyry I have already described from Laxey, except that there is no signs of schistosity in this one. It is somewhat similar to a felsite I obtained in the neighbourhood of Snowdon, that one only differing from the Langness specimen by contain-

ing small cubes of pyrites and having the felsitic base of a strong green colour.

Having now reached the limit of Castletown Bay in this direction, we will return and take the opposite course.

#### FROM CASTLETOWN TO PORT ERIN.

The walk along the coast from Castletown to Port Erin is an exceedingly fine one from a geological point of view. Immediately on leaving the town the Carboniferous limestone is seen exposed on the shore in beds of about two feet in thickness, of a very dark colour, dense texture, and very fossiliferous. Some little distance further is a quarry where the stone is obtained and dressed for building purposes. The rock breaks with the conchoidal fracture peculiar to the mountain limestone and gives forth a metallic sound when struck with the hammer. It appears to form a fairly good building stone, but I should imagine it would not last long in such an exposed neighbourhood. Near by are some lime-kilns hollowed out of the cliffs, showing that at some time the stone has been burned for lime, but the kilns appear to be now disused. On following the coast-line for a short distance further the limestone disappears, and in its place there is found an immense sheet of basalt accompanied by beds of volcanic agglomerate, ash and dust. Some little distance out to sea, and only accessible at low tide, there stands the huge basaltic pile known as the Scarlet Stack. These rocks form a narrow strip all along the coast from the south-west of Castletown, by the Scarlet Stack, and terminate near the Poolvash Bay. They are splendidly exposed as a rugged, low cliff, or foreshore, while their direction seaward is marked by the low-water reef known as "Lheeah Rio" in Castletown Bay. This huge contemporaneous sheet is divided into various deposits differing both in regard to structural characteristics and the time of formation. Beds of coarse agglomerate, containing baked fragments of rock, are seen. Ledges of fine tuff are also visible. Ridges of exceedingly vesicular lava appear, and a broad dyke of basalt or dolerite breaks through the tuffs and agglomerates, and eventually finishes in the Scarlet Stack. Here, without any doubt, we see the signs, and what is left, of an ancient volcano. The ash and agglomerate beds in some instances contain fossiliferous remains of various kinds, showing that some portion of the eruption, at any rate, was submarine. The broad ridges of vesicular lava, however, point to eruptions at a later date and when a land surface existed. The basalt is of one or two different kinds, and I shall describe them later when referring to their microscopic examination.

The colour of this sheet varies in different places according to the particular deposit. The normal

basalt is a particularly dark green—almost black; the vesicular beds are a dark brownish green, while the tuffs, etc., are a dirty sage green. All are exceedingly weathered and decomposed; in most cases the result is that their colours are darkened, but in some instances I noticed the vesicular bands of a reddish hue, probably due to the decomposition of the iron. Their structure and weight are also different, the ordinary basalt being heavy, dense, exceedingly tough, and hard. The vesicular formation is naturally comparatively lighter, and of a more open texture. Some of the vesicles were filled with calcite and have a great resemblance to the "Toadstone" of Derbyshire. The tuffs and agglomerates themselves of course vary in texture and weight, some of the finer kinds being so far decomposed as to crumble in the hands.

An examination of a thin section of what appears to be the normal basalt under the microscope shows the rock to consist of a ground base composed of small lath-shaped crystals of felspar, patches of brownish augite, with flakes and minute cubes of magnetite, throughout which are scattered larger crystals of idiomorphic plagioclase, augite, olivine, and larger patches of magnetite. The phenocrysts of felspar exhibit twinning on the albite and pericline system, and contain inclusions of fluid cavities as negative crystals. The ground mass in many cases shows a fluxional arrangement of the little lath-shaped crystals around the large crystals. Some of the olivine exhibits signs of decomposition, small specks and streaks of serpentine appearing. Pseudomorphs of calcite also occur in this section.

On examining a thin slice of rock taken from one of the vesicular beds mentioned, I found a ground base resembling that of the basalt previously described. The phenocrysts, however, which are felspar and augite are very much decomposed. This rock shows itself to be very different from the first-mentioned. Being taken from near the surface of a ridge of vesicular lava, it is seen to contain numerous small spheroidal and oval cavities, many of which are filled in with calcite. These cavities are generally lined with little fringes of chlorite, and the calcite filling up the remainder of the space shows cleavage and double refraction very strongly. This rock has undergone decomposition to some extent, the ground mass being very dark and the minerals generally difficult of identification.

The most interesting mineral occurring in this section, and which is doubtless a decomposition product, is analcime. It is found as small circular or elliptical spherulites in the cavities referred to, and is never seen in the general ground base. The spherulites are all of a fibrous radiating character, and are generally found round the sides of the

vesicles, but occasionally they occur completely isolated and of perfect form. In the calcite they are seen in some instances to entirely fill up the cavities, and then the spherulitic structure can only be observed with the aid of the polarizer. Viewed with the polarizer these spherulites show very strong pleochroism, polarizing vividly in many colours. The circular ones exhibit a faint bluish cross, while the elliptical ones show two of these.

A microscopic examination of the fragmentary rocks show them to be in nearly all cases very much decomposed. Chlorite is generally present in fairly large quantities, lining all the cavities in fibrous fringes, and sometimes filling up the whole of the interstitial space between the fragmentary matter. The ground mass is generally very dark, and occasionally opaque, the lath-shaped crystals being again present, but very small. The large felspar crystals which appear are very much decomposed, as is the olivine which is present.

After walking for some distance over this volcanic sheet the scenery changes, and the wild, rugged basaltic rocks give place once more to the gently sloping beds of limestone. At the head of Poolvash Bay there is a marble quarry where an exceedingly hard dark-coloured marble occurs in thin beds and accompanied by similar beds of shale. The rock is not unlike Derbyshire black marble, and is said to take almost as high a polish. It is from a quarry in this vicinity that Bishop Wilson obtained the black marble which he presented to St. Paul's Cathedral, and from which were constructed the flights of steps at its western and southern doors. The quarry is not a very large one, and does not appear to be worked at the present time.

All along the coast from Poolvash Quarry to Port St. Mary the rock formations are very peculiar and interesting. The sea at this point is gradually washing away the land, and for a long distance there is an exposed section of about fifteen feet in depth. At one point this consists of boulder clay, of which there is such a great amount all over the island. This boulder clay differs somewhat from the more ordinary drift of the island, being composed of a very stiff red clay containing large pebbles and boulders. These stones are not nearly so numerous as in the drift I noticed in other parts of the island.

Near the hamlet of Strandhall there is a peculiar bed of gritstone about four or five feet thick, and of a very deep purple colour. The beds of this stone are exceedingly wavy, looking like gigantic ripple marks, and much larger than any I have before observed. The grit is a remarkably coarse one, and gets coarser lower down, being in fact a fine conglomerate at the bottom. The rock does not seem to extend very far on either side, and is

exposed some six or eight feet above the present surface of the shingle. It is suffering very much from the action of the waves undermining the softer formation beneath. Thus, having its support removed, it gradually breaks up. At the time of my examination I saw a large block, some five feet long, which appeared to have only recently broken off. The rock being a grit, and practically a small conglomerate, shows it to have been deposited in shallow water, and it is evident from the fact of the coarser grit being found at the bottom that it was deposited on the site of an area of depression. It very probably is the remains of an ancient shore line. The ripple marks too would tend to prove its littoral origin. This bed is both underlain and overlain to some extent by the boulder-clay, and its time of origin, therefore, seems to be the Inter-glacial period.

#### EXCURSION TO PORT ST. MARY.

At this place there is a small patch of Carboniferous limestone, which forms "Kallow Point," and which has been faulted into this position by the north-south-west to east-north-east fault which bounds the Carboniferous series on this side and which strikes across the sea from the neighbourhood of Kentraugh. This little isolated patch of limestone, which just shows the basal beds, looks very curious standing alone amongst the older formations, and is for the geological student an instructive example of a fault.

A little to the south-west of Port St. Mary there may be observed on a map of the Isle of Man a crescent-shaped bay some short distance to the east of Spanish Head. It is at this place where the celebrated "Chasms" occur, and the bay is the result of large masses of rock having become detached from time to time. The chasms are twelve in number, and are wide fissures or rendings in the rocky platform at the head of the bay in question. The formation at this point consists of dark-blue fibrous flags of Lower Silurian age, having a slight dip towards the sea, which is continually undermining the precipice. On examining the rocky platform about eighty yards from the brink of the precipice a line of subsidence is observed running east to west. Between this and the cliff are a series of parallel fissures of great depth, and about a yard wide, while others also penetrate to a similar depth at right angles to the first. The area of the most disturbed mass is, I believe, about twelve thousand square yards. Whether these wonderful chasms are the result of seismic disturbance in past ages, or whether they are in connection with faulting, I cannot say. Either theory would be supported by facts, since we have abundant evidence of ancient volcanic eruptions within a few miles, and only a very short distance away

is the large fault which has brought in the Carboniferous rocks. This fault-line, in fact, if continued south-west would pass almost across the bay named. The continual undermining of a set of beds gently sloping seawards might also tend to bring about very similar results.

*(To be continued.)*

ACETYLENE GAS AND ITS VALUE TO SCIENTIFIC STUDENTS.—Among the modern valuable products of applied science, few will be more useful to the scientific student, and his necessary companion, the photographer, than the new acetylene gas. The brilliancy of this illuminant is nearly twenty times greater than that of ordinary coal gas. Its quality is so nearly approaching that of sunlight, that colours which are visible in daytime, but fugitive in artificial light, are brightly visible under the influence of burning acetylene gas. We have found it most useful in carrying on the examination of shells and other natural objects during these long winter evenings, which have rendered some of our collections useless, on account of the difficulty in separating delicate pinks, yellows and other colours dependent on daylight.

Now that the carbide of calcium, from which the acetylene gas is produced in quantities, has been commercially manufactured, and portable lamps for its use are being made, this beautiful light will soon be available for domestic use, and be as cheap, or even less costly, than paraffin oil. The intensity of acetylene is so great that photographers find they can obtain better negatives and prints by its use than from an electric arc lamp. For lantern exhibitions it is equal to the oxy-hydrogen light. Entomologists will find this an admirable and portable light for attracting insects at night.

From other accounts we receive of this new illuminant, there is every reason to believe the time will shortly arrive when private houses generally will be illuminated by it. It is independent of all gas works, with their troublesome and expensive mains, whilst its general application would be attended with as little danger, so we learn, as ordinary coal gas.

HOW FERMENTATION GERMS ARE SPREAD.—The diffusion of alcoholic ferments by insects, especially by ants and flies, has been a subject of experiment by Dr. Amedeo Berlese, an Italian biologist. It is found not only that yeasts, varying according to their source, are conveyed by these insects, but that they live and multiply in the interior of flies and are doubtless largely preserved during the cold season in the bodies of insects. The part played by living organisms in disseminating the yeasts to which the fermentation of fruits, etc., is due, must be very much greater than that by air.—*J. H. Cooke, Lincoln.*

## CASUAL AND ALIEN PLANTS IN NORTH LONDON.

By J. E. COOPER.

THE following lists are not regarded by any means complete, still they may be of interest as a contribution towards the casual flora of North London. The plants here noted have all come under my own notice during the last fourteen years. During this period there has been a good deal of building in progress in this neighbourhood, and the land from time to time left waste has produced the greater number of the plants here enumerated.

The distinction between "casuals" and "aliens" is often arbitrary. In this, as in the nomenclature generally, the "London Catalogue" (ninth edition) is taken as a standard list.

As far as I know, all these plants have been introduced, and are not found truly wild in this neighbourhood. They seldom reappear in any one spot after the first year, being generally crowded out by other and stronger species.

I am indebted to Mr. J. G. Baker, of Kew, for kindly naming some of the aliens.

## CASUALS.

- Ranunculus acris*, L. East Finchley.  
*Erysimum cheiranthoides*, L. East Finchley and Crouch End.  
*Diphysalis tenuifolia*, D. C. East Finchley.  
*Lepidium ruderale*, L. Crouch End (two localities).  
*Thlaspi arvense*, L. Crouch End and Muswell Hill.  
*Dianthus armeria*, L. In a wood at East Finchley (Possibly indigenous, not seen for several years now).  
*Silene noctiflora*, L. Crouch End.  
*Lycinus githago*, Scop. In several waste spots.  
*Spergula arvensis*, L. Highgate and Crouch End.  
*Rhamnus catharticus*, L. East Finchley, a single bush, probably planted.  
*Medicago denticulata*, Willd. Crouch End.  
*Trifolium fragiferum*, L. Colney Hatch Lane.  
*Lathyrus hirsutus*, L. Crouch End.  
*Potentilla argentea*, L. Highgate.  
*Daucus carota*, L. Colney Hatch Lane.  
*Galium tinctoria*, Stokes. Highgate.  
*Senecio jacobinae*, L. Highgate.  
*Cnicus cretaceus*, Roth. Crouch End.  
*Centaurea cyanus*, L. Crouch End (two localities).  
*Solanum nigrum*, L. Highgate.  
*Atriplex hibernica*, L. Crouch End.  
*Calamintha thymifolia*, Moench. Crouch End.  
*Galopis tetralix*, L. Highgate Wood (in a clearing).  
*Scleranthus annuus*, L. Crouch End.  
*Chenopodium polyspermum*, L. Highgate and Crouch End.

- C. murale*, L. Muswell Hill.  
*C. ulicum*, L. Hampstead and Crouch End.  
*Polygonum diometorum*, L. Muswell Hill and Crouch End.  
*Rumex maritimus*, L. Crouch End (two localities).  
*Mercurialis annua*, L. Crouch End.  
*Alopecurus myosuroides*, Huds. Crouch End (two localities).  
*Apera spica-venti*, Beauv. Crouch End.

## ALIENS.

- Delphinium ajacis*, Reichb. Crouch End.  
*Alysson incanum*, L. Muswell Hill and Crouch End.  
*A. maritimum*, L. Crouch End.  
*Erysimum perfoliatum*, Crantz. Crouch End.  
*Camelina sativa*, Crantz. Crouch End (two localities).  
*Raphistrum rugosum*. Crouch End (two localities).  
*Safenaria vaccaria*, L. Crouch End (two localities).  
*Linum usitatissimum*, L. Highgate and Crouch End.  
*Oxalis corniculata*, L. Muswell Hill.  
*Impatiens parviflora*, D. C. Hampstead and Crouch End.  
*Melilotus alba*, Desr. Crouch End.  
*Trifolium hybridum*, L. East Finchley and Crouch End.  
*Vicia* — (sp. not yet identified). Crouch End.  
*Carum carvi*, L. Crouch End.  
*Erigeron canadense*, L. Highgate.  
*Ambrosia trifida*. Highgate.  
*Plantago arenaria*, Waldst. and Kit. Crouch End.  
*Amaranthus retroflexus*, L. East Finchley and Crouch End.  
*Cannabis sativa*. Crouch End.  
*Crocus vernus*, All. Colney Hatch.  
*Panicum crus-galli*, L. Highgate and Crouch End.  
*P. miliaceum*, L. Muswell Hill and Highgate.  
*P. capillare*, L. Crouch End.  
*Setaria gouca*, Beauv. Muswell Hill, Highgate and Crouch End.  
*S. viridis*, Beauv. Highgate and Crouch End.  
*Phalaris canariensis*, L. Crouch End (two localities).

## ABNORMAL FORMS.

The following abnormal specimens have also occurred:

- Trifolium repens*, L., with foliaceous calyx, at Crouch End.  
*Leontodon autumnalis*, L., with lemon-yellow blossoms, at Muswell Hill.  
*Plantago lanceolata*, L. A plant at Crouch End had three peduncles, each of which bore a complete plant in miniature at its summit.

*Atriplex patula*, L. A curiously fasciated example, at Highgate.

*Setaria viridis*, L. One or two plants at Crouch End had the spikes branched into three.

*Alopecurus pratensis*, L. A number of plants in an old meadow at Highgate had the outer glumes of the upper spikelets lengthened to four or five times their usual size, and twisted in a fantastic manner.

*Lolium perenne*, L. Some specimens have the spikelets crowded together, others have an irregular panicle instead of the simple spike; others have a perfectly regular flat panicle in which each spikelet of the normal spike is replaced by a short spike. The length of the awns varies very considerably.

93, Southwood Lane,  
Highgate, London, N.

## ORCADIAN RAMBLES.

By ROBERT GODFREY.

(Continued from page 205.)

### II.—STROMNESS TO THE LOCH OF SKAILL.

ON the following morning, May 26th, I set out under unfavourable weather conditions for the Loch of Skail, six miles to the north of Stromness. On passing through the town, I left the main road for one that led hillwards, and I severed my connection with roadways at a small, unnamed loch with a surrounding marsh, whose surface was bright with marsh marigold, cuckoo-pint and sedges. For a while thereafter I threaded my way along narrow strips between ploughed lands until I reached a knowe stripped of its surface herbage, from which I had a splendid view of the great lochs and the heather hills on every side. Unable any longer to resist the possible attractions of the hills, I crossed the intervening moorland and stubble to those lying on the west. During my passage I was unceasingly tormented by the peewees—birds that literally swarm here—and I noticed scarcely any diminution in their numbers, even in the haunts of the golden plover.

I was disappointed in finding the plough at work practically on the hill-top, and I had not expected to see so many crofts scattered up and down. The surface here, of moss and heather, was bare in many places, and the small heaps of drying turf displayed the surface-skinning in full process. The first indications of my having reached a somewhat wilder region were given by the appearance of a pair of ravens that slowly beat about a hill-top in front of me. The display of loch scenery from the hill-crest was magnificent, but dark cloudy skies hanging ominously over me, considerably damped my prospects.

The further side of the hill, though steeper, presented no better attractions. Still, its uneven surface rendered it more enticing; but the shortness of its heather covering prevented its forming suitable inducements for skulking birds. Below me, to the left, was a marsh, caused apparently by peat-digging, beyond which lay another ugly bare patch, and cultivated ground stretched thence to the sea. In front and to my right lay a fine series of lochs,

of which Stennes and Harray were the chief. I descended the hill slowly, ever hoping to meet with a hen harrier, and at the hill-foot I entered cultivated land just before the long-threatened rain began to fall in a steady drizzle. In crossing this ground to the nearest loch, the mill-dam of Stennes, I flushed a corncrake from a dyke-end. The bird had no doubt been running along the dyke-foot in front of me. It flew rapidly with a side-to-side motion, and on alighting covered its head at once and ran off.

The marsh adjoining the loch afforded in its extensive stretches of bogbean, rushes, equisetum and reeds, splendid cover for birds, and the various tenants of the swamp soon hailed my approach with clamorous outcry. Peewees and redshanks harassed me persistently, and the dunlin would await me by the waterside and fly off trilling. The blackheaded gulls, from their uproar when disturbed, were evidently nesting, and parties of mallard rose as I advanced, whilst a pair of tufted ducks, most confiding birds, waited my close approach before they shifted, at the duck's instigation, to another part of the loch. Coots also were common, and a pair of mute swans were swimming on the edge of the reeds. More interesting to me, however, than any of these birds was the presence of the sedge-warbler, a number of which species in full song rendered the marsh vocal with their churring, as they skulked the while in the thick and splendid shelter.

After an unnecessarily long halt here, I turned again to the head of the loch, and renewed my journey northwards over the hills. The monotony of the peewee's call was tiresome, and the persistent presence of this bird rendered anything else acceptable as a change. A pair of common gulls passed over me once, and at a ruin, I met with a pied wagtail. Larks were, of course, unfailingly present, and the ring plovers put in an appearance at a portion of the hills where the turf had been stripped off. These latter birds afforded



me some relief as they ran over the heather tufts and across the patches of bare ground, piping the while. The land became more distinctly cultivated as I advanced, and in the neighbourhood of the Loch of Skaill it had little of a wild nature about it at all. The drizzle still continued slightly, and a cold wind was exceedingly refreshing.

The nearness of the loch, made famous in my day-dreams of Orkney before I had left home, now induced me to quicken my steps, and I soon gained the side of a small iris-fringed stream flowing into it. Again my old companions, peewees and red-shanks, got up to torment me, and I found eggs of both species, out of which the young birds had safely come, but I did not actually handle the young. My first scrutiny of the loch was disappointing; coots were common, and mute swans were on the water, whilst a colony of blackheaded and common gulls occupied a small island, and a few arctic terns were about. Not being at all satisfied with such life, I was on the point of leaving the loch for some other haunt when I thought I had better take a look at an odd swan sitting on the bank, and turning my glass upon the bird I was surprised to see that it was not a mute swan at all, but a whooper. I at once planned a careful approach; but I soon saw that the bird had no fear, as he placed his head back amongst his plumage, and did not move till I had come within a short distance of him. His head was rusty tinged, and on the back of the neck some way down was a rusty ring; otherwise his plumage was white.

On the ground the whooper stood with body horizontal and long neck almost quite erect. He walked very sedately, throwing out his foot comically and spreading it as he brought it down, whilst his breast projected in an unseemly manner. As he walked he uttered a more or less clanging cry, "hoomp, whoomp," and occasionally moved his tail sharply in a horizontal direction. The shape of his head was markedly triangular, whilst that of the mute swan was round, and the whooper, though he sometimes had a slight curve on his neck, carried it far more nearly erect than the mute swan. A pair of the latter birds were often careering about the loch, one of them flying clear of the water altogether, and this performance acted most powerfully on the whooper, who uttered a "whoop, whoop," in regret at his inability to fly. The whooper's right wing was broken, as was seen when he flapped it, which accounted for his stay here. Several times he lowered his head suddenly and raised it again, an action that is common to many species of birds. The bird had moved into the water on my near approach, and was resting a few yards from the shore, when a male mute swam in his direction and displayed his enmity towards him, so that the whooper was forced to come ashore at once, and he renewed his uproar

on the land. Once he stretched out his long slim neck and shook his head most comically several times. During the remainder of my stay the mute swan kept guard over him, and the whooper was continually clanging. Repeatedly the whooper stood with head and neck outstretched and beat his wings, as if anxious, after his long detention on Skaill, of reaching once more the spot where his companions were, and he uttered the while a far louder continuous cry.

When at length I could learn no more of the bird's habits, I continued my course along the grassy margin of the loch, and was presently attracted by four swans that had risen clanging, disturbed by a passing horseman, and were flying at some height above the water. These birds displayed entirely black bills, and puzzled me for a time. I was destined, however, to have a long acquaintanceship with them, and found that they were immature mute swans. That portion of the bill which in the adult is yellow, was in these birds black, though not so intensely black as the rest. They had also some brown about the wings and the crown of the head. I had never before heard mute swans clanging, and I have since wondered whether the presence of the noisy whooper may not have induced these birds to attempt an imitation of his cry.

Some distance below the whooper's haunt I passed a mute swan on her nest, and at the foot of the loch I became an attraction for terns. Here also I noticed a pair of dunlins and a little grebe on the water. The end of the loch was bordered by swampy ground that afforded inducements for wild fowl, and coots and mallard were breeding there. I encountered a mallard shuffling along to the water with two young birds in her trail, and catching one of the young birds as it rested in a depression, I examined its soft, downy plumage, and released it again, when it promptly dived. On advancing to the spot from which I had seen the mallard rise, I noticed other youngsters lying close, and set them in motion by catching one of them, which I again released, delighted to watch the activity of its movements.

In following the sinuous outline of the loch I came to an equisetum marsh occupied by a colony of blackheaded gulls. Owing to the swampy nature of the ground, the nests required to be firmer than usual and raised above the level of possible floods. I saw six nests with eggs, and was completely astonished to note the position of the gullery close to a high road. The immature mute swans also had their quarters here, and were being tyrannized over by an adult swan. The immature birds were smaller than the adults and carried their heads erect, whilst the adult bird, with wings raised to catch the gale, and neck thrown proudly back, swam boldly on to the

attack, and invariably forced them to retreat. The immature birds repeatedly rose and circled about the loch, keeping entirely clear of the surface, and clanging in flight.

I passed from the gullery to the road which runs along the north-east side of the loch, and in skirting the water's edge I met with the common sandpiper, and noted a party of tufted ducks and

a single goldeneye on the water. At the head of the loch, the byroad joins the main road for Stromness, but before returning thither, I visited another water of fair size, Clumly Loch, on which I did not find the bird life to differ much from that noted on the lochs already described.

(To be continued.)

## COLORATION AND VARIATION OF BRITISH EXTRA-MARINE MOLLUSCA.

By ARTHUR E. BOYCOTT.

(Continued from page 198.)

PASSING over *Avianta*, *Cryptomphalus* (? cryptic on or by walls, etc.) and others about which no very striking suggestions have been made, we come to the conspicuous group comprising the two species of *Tachea*. It is here that bright pigmentation is most developed in British terrestrial species, and there have naturally been many suggestions made to account both for the brightness and variety of the colours. These colours are often, especially in *Tachea nemoralis*, accentuated by the contrast of black bands, which bands play some part in many, if not all, of the theories which have been put forward concerning the group. In certain isolated cases the colours appear to be cryptic. Thus, Mr. A. W. Brown tells me that he has on several occasions noticed a striking resemblance between a red-brown form of *Tachea* and the dead beech leaves among which it is found. This seems to be the var. *fagorum*, of Weinland, referred to as an example of cryptic coloration by J. W. Taylor (1). But it can hardly be supposed that the ordinary reds and yellows occurring in the usual situations are cryptic. To us, at any rate, and also apparently to thrushes, blackbirds, etc., they are exceedingly obvious, though my brother tells me that he has often found the dark, five-banded *rubella* form of *T. nemoralis* difficult to detect on a roadside bank (2), especially at dusk. The possibility of coloration being nocturnally cryptic must always be borne in mind when considering species which chiefly move during twilight and darkness, just as in considering epigamic colours we must own that our knowledge of colour-vision and aesthetic sense in mollusca (and in birds, etc., for cryptic and sematic colours) is very incomplete.

It has been ingeniously suggested by W. H. Dall, "that the tendency to striped markings would probably aid in the concealment of the

shells among the lights and shadows of the grass and herbage" (3). John T. Carrington (4) has advanced what seems to me a capital objection to this theory, viz., that "when the animal is at rest or feeding, with few exceptions, the natural position of the stripes on the shells is across the grass and not in the direction of its growth," though, of course, some of the stripes run much in the same direction, and a practical re-examination has made me less certain than I was that the majority are transverse. F. E. Beddard (5) says the colour is either sematic or epigamic. He very naturally objects to regarding them as epigamic in hermaphrodite, but not, it must be remembered, as a rule, self-fertilizing animals. Indeed, differences in shell-form has been definitely associated with sex only in very few of the species in which the sexes are separate, and Eimer and C. Darwin (6) are agreed that sexual selection has not modified mollusca. That they are not sematic in character is sufficiently evidenced, I think, by the fact that such quantities are destroyed by birds. Everyone knows the "thrushes' stones" at which the birds immolate their captures, and, though perhaps more abundant, though it may be very likely only more obvious, in winter, they are common enough in summer, which shows that the birds are really fond of this diet, and are not merely driven to it when softer and more succulent food is absent (7). I have, too, noticed very well-fed fowls picking *Frititicoia rufescens* out of a rockery with evident delight.

It seems going a long way to suggest that the

(1) J. W. Taylor, "Monograph," p. 95.

(2) SCIENCE-GOSSIP, N.S., iii. (1896), p. 123. For an illustration see "With Nature and a Camera," R. and C. Kearton (1897), p. 294.

(3) "Animal Coloration" (1892), p. 56. I should like to say that it was through no fault of mine that Mr. Beddard was misquoted ("cryptic" for "sematic") in the "Zoologist" (3), xx. (1896), p. 68.

(4) "Descent" (1871), i., p. 326.

(5) A decrease in the abundance of *Tachea* and *Avianta* round Manchester has been partially attributed to the increase of blackbirds and thrushes.—"Conchologist," i. (1891), p. 29.

(1) Monograph, part ii., p. 94 (1895).

(2) I suppose the preference which *Tachea* shows for road banks over those in fields is because of the greater abundance of varied and coarser herbage on the former, while the latter are generally very grassy, and, which may also have its effect, more eaten over by cattle.

colours may be protectively pseudo-semantic, *i.e.*, imitating some other (non-existent) distasteful animal, or perhaps following out the general rule that semantic colours are bright. There is yet a fourth possibility that the colours are, at present, at any rate, of no particular use. That is to say—and I hope the idea, with which I am inclined to agree, is not very rank heresy—*Tachea* is having what might be described as a "gay time"; they reproduce so numerous, and apparently suffer from the attacks of so few enemies, that they are varying in all sorts of ways. The conditions of their existence are so favourable, that most of the forms which accidentally (I suppose we must say) arise, are found good, and capable of living, thriving, and multiplying in their surroundings. They further possess very considerable powers of naturalization, as is seen in the North American United States. The very opposite of this is found in, *e.g.*, *Fruticicola cantiana*, which is apparently very difficult to transplant with success, and inhabits very restricted and circumscribed areas, even where it is not uncommon. I have failed to introduce it from near Oxford into Herefordshire, and Mr. E. W. Swanton has also failed to naturalize it in Somerset (in some parts of which it occurs). Other experiments seem to have been more successful however<sup>(1)</sup>.

Considerable plasticity associated with some permanence in the resultant forms is *a priori* rather improbable in species which are keenly engaged in the struggle for existence, especially where great abundance of individuals is superadded.

There remain one or two more things to be mentioned. From a suggestion of L. E. Adams<sup>(2)</sup> it seems possible that the rather bright, conspicuous colouring of *Fruticicola cantiana* may be semantic, as, according to that authority, it is never eaten by birds.

W. M. Webb<sup>(3)</sup> has recorded some interesting observations on *Clausilia*. He shows that this genus is cryptically shaped and coloured, with reference to such botanical remains as shrivelled bud-scales, etc. I cannot think this a very good case, as our *Clausilia* are not very geophilous (except *C. rolfii*), and do not, as a rule, occur in the situations indicated. If it is a complete and genuine case, and I am not denying that in many instances it does hold good, one would expect to find *Clausilia* habitually living in situations where it would be among the objects to which it has a resemblance. W. Nelson finds that *C. rolfii* is protectively coloured among dead leaves<sup>(4)</sup>.

J. R. Masefield finds *Fruticicola fusca* in Staffordshire on the root leaves of *Lychnis dioica*, and points out "the striking resemblance which it bears to the dead seed-capsules of that plant, especially when they are wet and transparent with dew or rain"<sup>(5)</sup>. J. F. Whiteaves, who found *Chilotrema lapicida* on brambles, remarks that "it is rather difficult to find, as its shell very much resembles in colour the dark purple hue of the bramble"<sup>(6)</sup>.

Among the different classes distinguished by their mode of coloration we may note a significant difference in hibernation. When it was mentioned earlier in this article that *Xerophila* was resistant to cold, comparison was intended rather with *Cryptomphalus* and *Tachea*, than with the smaller, horn-coloured genera. The brightly-coloured species are typical of a warmer climate than England, and in consequence they hibernate in comparatively mild weather. *Cryptomphalus*, for example, hibernate for a long time, no doubt finding an ordinary English winter rather too severe for its tastes. From September to April, as far as my experience goes, is not an unusual period for it to stay in retirement<sup>(7)</sup>. That *Cryptomphalus* does not resist cold well is shown by the large numbers of dead specimens which occur after a winter of some severity. I have noticed in Hereford that it is fond of hibernating at the base of various close-growing garden plants, especially a sort of flag-grass, and after the severe winter of 1894-5 hardly a live specimen was to be found in these situations<sup>(8)</sup>. I have also found large numbers of empty shells congregated together in holes in walls, with every appearance (epiphragm, etc.) of having died during hibernation<sup>(9)</sup>. *Tachea* has a similar, though not so extended, range of hibernation. November to March might nearly represent the normal period<sup>(10)</sup>, but they do not, as a rule, occur in abundance between September and April.

On the other hand, the smaller species, such as *Hyalinia*, are much more hardy. They are characteristic of a temperate climate, and appear to be only driven in, and that for a short time, by very severe frosts. *Vitina fellucida*, an essentially boreal species, seems to revel in cold weather; in the summer it aestivates very deeply and firmly, and it is often difficult to find a live specimen

<sup>(1)</sup> L. E. Adams, *op. cit.*, p. 82.

<sup>(2)</sup> "List of Oxfordshire Mollusca" (1857), p. 8. This is a remarkably good and interesting local fauna.

<sup>(3)</sup> May 27th, in "Zoologist" (3) ix. (1885), p. 424. Immature specimens are not infrequently found moving fairly freely in the middle of winter, *e.g.*, December 19th, 1891.

<sup>(4)</sup> The places chosen for hibernation by this species often do not seem of the safest. *Tachea* generally chooses the bottom of a hedge, where they are not difficult to find, which offers a good deal of protection. *Cryptomphalus* sometimes burrows in the earth (W. E. Collinge, quoted by A. H. Cooke, *op. cit.*, p. 41) for additional security.

<sup>(5)</sup> Cf. "Zoologist" (3), v. (1881), p. 241. In spring specimens of all ages apparently killed by cold are quite common.

<sup>(6)</sup> On December 26th, 1896, I was surprised to find a single straggling *Tachea hortensis fasciata*, B. F. 12415, near Hereford, crawling about on a hedge-bank. Owing to the cold spring, they have not yet appeared freely round here (April 30th).

<sup>(7)</sup> J. C. Blackshaw, "Naturalists' Journal," v. (1896), p. 22. Hampshire to near Southampton. Baille in H. W. Kay, "Innerval of Shells."

<sup>(8)</sup> *Op. cit.*, p. 75.

<sup>(9)</sup> See *Science-Gossip*, N.S., II, p. 227 (1st, Jan. (April), 1896).

<sup>(10)</sup> "Conchologist" (1) (1871), p. 5.

during the warm weather. I have, of course, observed exceptions to this rule, but it appears to be a general one in England (18). *Fruticicola fusca*, which seems a species of curious habits, and often difficult to find in localities where it is known to occur, is another very thin-shelled but very hardy species, as shown by the interesting observations of Chas. Ashford (19). The others, *Hyalinia*, *Chilotrema*, *Fruticicola*, etc., are also quite hardy; and *Hyalinia nitidula*, *Fruticicola hispida*, *Patula rotundata*, etc., may be seen moving about in severe weather. At the same time they are rather capricious. I have frequently found *Hyalinia nitidula* buried to a depth of several inches in the earth under stones in frosty weather, and W. E. Collinge has found other *Hyalinia*, *Fruticicola rufescens*, *F. hispida*, *Patula rotundata* and *Buliminus* in similar situations (20). *Cyclostoma*, a genus which is certainly not charac-

teristic of so northerly a country as England, seems tender and particularly liable to be killed by severe frosts, despite its thick shell and operculum. It also undergoes, as a rule, a pronounced aestivation—during which period I have noticed it buried in the earth—which is so much more marked in hotter climates. In some places (e.g., Kent, *vide* Mr. Bowell) *Tachea* aestivates in July or August, but this phenomenon does not seem to occur in Herefordshire. The whole question of hibernation appears to depend, to a large extent, on the individual peculiarity of species and individuals; for instance, on December 22nd, 1896, *Pupa umbilicata* was moving freely, while *Fruticicola rufescens*—more tender than *Hyalinia*—was hibernating, though only mildly, and under stones (21).

(To be continued.)

## NATURE NOTES FROM IRELAND.

BY JOHN H. BARBOUR.

THE few notes which follow are the results of more or less random observations in 1897, and the plants referred to were seen in this district within a radius of not more than about fifteen miles, with the exception of *Hieracium*. Those on the animals were limited similarly, except in the case of the egg of the goose, which was seen in South Ireland.

Primroses (*Primula vulgaris*) were in flower during the second week of January. A lark was also seen in that month. Crocuses were in full bloom in a garden in first week of February. Rose bushes and hawthorn (*Crataegus oxyacantha*) in full leaf-bud, coltsfoot (*Tussilago farfara*) in flower in second week of the same month. On February 20th, cuckoopint (*Arum maculatum*) in full leaf, wild geranium, Cape jasmine, and flowering currant in flower. February 26th, ground-ivy, purple dead-nettle (*Lamium purpureum*) in flower, and hawthorn in full leaf. February 27th, sweet briar in full leaf, gooseberry leaves bursting, and hazel (*Corylus avellana*) in flower.

March 1st, speedwell (*Veronica chamaedrys*) in flower, marsh-mallow (*Caitha palustris*) in flower, and ash tree in full leaf-bud. March 7th, woodbine and elder in leaf. Frog-spawn seen on that day, as were also swifts. March 28th, sycamore bursting into leaf, and on 25th of that month a thrush's nest with three eggs in it was noticed in this district.

On November 28th, borage was still in flower, and ripe red currants, I heard, were still to be had in a garden near here. December 4th, dead nettle (*Lamium purpureum*) yet flowered, and laburnum was well in leaf-bud. During the week ending December 18th, a butterfly was seen.

At the Giant's Causeway (Portrush), in June, I saw a rather peculiar *Hieracium* as regards flowering. On one capitellum was the abnormal condition of a flower, being partly open and partly closed at the same time; exactly one half of the flowerets were widely expanded and open, and the other half tightly closed. Diagrammatically, it might be represented by the accompanying lines.

It was about mid-day when noticed, and so it could not have been due to evening tendency to closure. Moreover, being in a fully open spot, no trees or shade of any kind being near, it could not have been due to the direct heliotropic influence of light. When in Tipperary, in August, a peculiarly malformed egg laid by a goose in the district I was in, was shown to me. It was fairly large, and is best described by simply saying that it was very like, in shape, to that of the shell of a heart-shaped sea-urchin. Where the indentations were, it seemed thickened, rough and warty.

Bangor, Co. Down, Ireland.

(18) Cf. J. F. Whiteaves, "List of Mollusca of Oxfordshire," Ashmolean Soc. (1857), p. 6; W. E. Collinge, in "Zoologist" (3) xiv. p. 467; S. S. Pearce, *ibid* (3) v. p. 364; B. G. Jeffreys, *BC.*, i. p. 156. Whiteaves thinks that the large number of empty shells found in summer is due to the fact that "from the very large aperture and the extreme tenuity of the shell, it is often attacked by ants and other insects."

(19) Quart. Journ. Conch. i. p. 180; quoted by R. Rimmer, L. F. W. Shells (1880), p. 131. E. W. Swanton (Nat. Journ.,

1897, p. 18), says it is not inconvenienced by excessive heat or cold.

(20) "Naturalist" (1891), p. 75; "Conchologist" ii. (1892), p. 29, quoted by A. H. Cooke, *op. cit.*, p. 41.

(21) E. W. Swanton (Nat. Journ., 1897, p. 17), finds that many species move about readily in cold weather, and is of opinion that "very few are killed by frost, even in the severest weather." *Fruticicola cantiana* may be seen crawling about in the severest weather.

## FOREIGN VARIETIES OF BRITISH LAND AND FRESHWATER MOLLUSCA.

BY T. D. A. COCKERELL.

(Continued from page 45.)

## LIMNÆA.

**I**N this genus I give simply a list of names, with a few data as to synonyms and localities. Many of the names, doubtless, are synonyms; some probably represent distinct species.

LIMNÆA PEREGRINA, Müller.

(a) Subsp. LAGOTIS, Schr., 1803. This, as generally understood, seems to belong with *peregrina*, but I believe various *peregrina*-like forms of *L. auricularia* (as *acuta*, Jeffr.) are confused with it, and may be included among the varieties cited. Kobelt places our *burnetti* and *lacustris* under *lagotis*.

- v. *acutalis*, Morelet. Portugal.
- v. *alata*, Sporleder, in Kobelt.
- v. *wimmeriana*, Hazay.
- v. *trencaleonis*, Gass., syn. *amplæformis*, Kobelt.
- v. *attica*, Roth. Greece.
- v. *margaritacea*, West. Sweden.
- v. *janoviensis*, Krol.
- v. *confinis*, Mouss. Armenia.
- v. *andersoni*, Cless.
- v. *auricula*, West.
- v. *patula*, West. Siberia.
- v. *sandrii*, Kob.
- v. *biformis*, Kob.
- v. *lagotopsis*, Loc. Syria.
- v. *antiochiana*, Loc. Syria.
- v. *subpersica*, Loc. Syria.
- v. *neldyana*, Serv. Germany.
- v. *sandriiformis*, Serv. France.
- v. *solidior*, Mart.
- v. *solidissima*, Kob.

Kobelt includes under *lagotis* the subsp. *mucronata*, Held, with vars. *rubella*, *alpestris*, *baderseensis* and *bartolomæa*, all of Clessin, and doubtfully *v. virens*, Kstr.

(b) Subsp. OVATA, Drap. This is hardly a natural subspecies, but rather a mixture of lacustrine varieties of *peregrina*.

- v. *inflata*, Kob. Also said to occur in England
- v. *fontinalis*, Stud. Also British.
- f. *major*, West. Hungary.
- f. *minor*, West. France
- v. *dickini*, Kob
- v. *lundstromi*, Wes
- v. *finiana*, Haz
  - f. *ventricosa*, Haz.
  - f. *gracilis*, Haz
- v. *fulzshyana*, West.
- v. *fluminensis*, Cless. -- *lutea*, fide Taylor
- v. *intermedia*, Fér. in Lam. Also British.

- f. *pyramidalis*, Baud.
- f. *amygdalina*, Baud.
- f. *albinos*, Baud.
- f. *subscalaris*, Baud.
- f. *minor*, Loc.
- f. *acuta*, Loc.
- f. *inflata*, Loc.
- v. *boissii*, Dup. Also British.
- v. *tripolitana*, Let., in Loc.
- v. *patula*, Da C.
  - f. *ampullacea*, Rossm. Also British.
  - f. *major*, West.
  - f. *microcephala*, Kob.
  - f. *hemisphaerica*, Mke.
  - f. *subrotunda*, Borch.
  - f. *doliolum*, Kob.
  - f. *glacialis*, Dup. Pyrenees, 1100-2600 m.
- v. *obtusa*, Kob.
- v. *nouletiana*, Gass.
- v. *tenera*, Parr., in Kstr.
- v. *lacustrina*, Cless.
- v. *physella*, Serv.
- v. *balthica*, L. If this is really the Linnean shell, and belongs with *ovata*, it has priority over Draparnaud's name. It is supposed to be the *lineata*, Bean, of Forbes and Hanley, and *limosa* of author's. Brown's *lacustris* has been referred to it, but, according to Taylor, in error.
- v. *succinea*, Nilss.
- v. *nigrita*, Gass. MS., West. Encrusted specimens!
- v. *steenstrupi*, Cless. Iceland.
- v. *godetiana*, Cless. Switzerland.
- v. *hazayana*, Cless. Hungary. Taylor thinks this is *boissii*.
- v. *hasta*, Cless. Taylor says this is *succineiformis*, Shuttl.
- v. *besnardiana*, Serv. Germany.
- v. *mamillata*, Bgt. MS., Serv. Basses-Pyrenees.
  - A form near *glacialis*.
- v. *papilla*, Hartm. Switzerland, Armenia.
- v. *fasciata*, Kob. Germany.
- v. *acronica*, Stud.
- v. *albolimbata*, Kstr.
- v. *membranacea*, Porro. Very near *diaphana*, Parr.
- v. *pellucida*, Gass.
- v. *crassa*, Gass.
- v. *solida*, Pascal
- v. *eversa*, Von Mts. Very near our *lubrosa*.
- v. *major*, Baud

- v. minor*, Baud. There are also a *v. minor*, Locard, and a *v. minor*, Benson.
- v. ventricosa*, Baud.
- v. broeckii*, Colb.
- v. amplioides*, Jordan.
- v. strubeli*, Reib. C. Verde Is.
- v. succineaeformis*, Linds.
- v. sinistra*, Baud.
- v. ovata-normalis*, Erd.
- v. subovata*, Locard.
- v. ofaca*, Locard.
- v. colleti*, Hoyer.
- v. kantschatica*, Midd.
- Taylor considers the following four varieties to be identical with our *v. lutea*, Mont.:—*v. pachy-gastra*, Slav., *v. crassa*, Gass., *v. solida*, Pirona, *v. solidula*, Htm.
- (c) Subsp. PEREGRINA, Müll. Some of the forms referred here probably belong with *ovata*.
- v. elongatissima*, Gredl.
- v. producta*, West. This and the last are probably forms of *v. microstoma*.
- v. peregrina-ovata*, Rossm. Taylor says this is *v. vulgaris*, C. Pfr.
- v. africensis*, Ad. = *africana*, Bgt. = *microstoma*, Kob. = *paludarum*, Htm. = *elongata*, Cless.
- v. melanostoma*, Zgl. Very near *v. marginata*, Mich.
- f. *major*, West.
- v. marginata*, Mich. = *labrata*, Rossm. Also British.
- v. excerpta*, Htm.
- v. bakowskyana*, Cless.
- v. alpicola*, West. Very near to *microstoma*.
- v. syriaca*, Mouss. Jerusalem.
- v. planulata*, West.
- v. pustulata*, Gredl.
- v. oblita*, West.
- v. torquilla*, West. Siberia.
- v. styriaca*, West. Very near to *marginata*.
- f. *minor*, West.
- v. ambigua*, West.
- v. allepitschi*, West. = *raiblensis*, Cless. Taylor thinks this is probably *acuminata*, Jeff.
- v. atrata*, Chem.
- v. vattoni*, Bgt. Tunis.
- v. blauveri*, Shuttl. Switzerland.
- v. croatica*, Zgl. Croatia.
- v. virens*, Kob.
- v. peregriformis*, Loc. Syria.
- v. gibilmannica*, Calcara. Sicily. *v. solida*, Phil., is the same.
- v. thermalis*, Boub. = *salutiana*, Fagot. Pyrenees.
- v. putoni*, Bourgt. Vosges.
- v. heydeni*, Kob. = *attenuata*, Cless.
- v. fulva*, Zgl. in F. Schm.
- f. *tschapecki*, Cless.
- f. *curta*, Kob.
- v. curta*, Cless. Also British.
- v. meta*, West. Sweden.
- v. frisia*, Friedler.
- v. subdecollata*, Ckil. Brit. Nat., Apl., 1891, p. 62, = *decollata*, And., not Jeff.
- v. rivularis*, Scholtz.
- v. geisericola*, Bk. Iceland.
- v. nivalis*, Pini.
- f. *glacialis*, Pini.
- v. nubigena*, Bourgt. Alps.
- v. cyrniaca*, Mab. Corsica.
- v. langsdorffi*, Bourgt. Alpes Maritimes.
- v. reynesi*, Pal. France.
- v. albomarginata*, Cless. Near to *marginata*.
- v. acutispinata*, Cless. Taylor says this is *acuminata*.
- v. cinerea*, Cless. Tirol.
- v. pulchella*, Roff.
- v. compressa*, Htm. Taylor says this is our *oblonga*.
- v. bilabiata*, Htm. Near to *marginata*.
- v. cariosa*, Gené. Taylor says this and the next are *decollata*.
- v. corvosa*, Von. Gall.
- v. forma-gigantea*, Kob.
- v. rosea*, Gallenst.
- v. paupercola*, Poll.
- v. lilliputiana*, J. Colb.
- v. antiscianae*, Stef.
- v. caerulea*, Cless.
- v. vogtiana*, Mortillet.
- v. frigida*, Pini. A good species according to Kobelt's Catalogue.
- v. typica*, Küster.
- v. sandrii*, Parr.
- v. nimbosea*, Mart.
- v. ofaca*, Zgl.
- v. fuliginosa*, Zgl.
- v. consobrina*, Zgl.
- v. nitida*, Zgl. Also British.
- v. cornea*, Zgl.
- v. rivalis*, Stud.
- v. scalaris*, A. Braun = our *scalariforme*, Jeff.
- Limnaea peregrina* is in conchology what the aquatic Ranunculaceae are in botany, and in each case it is found that the different varieties are correlated with, and directly or indirectly due to, different conditions of life. Such things as the flow of the water, the substances it holds in solution, its temperature, its permanence and depth, all have their effect on *L. peregrina*. It is a most interesting study, productive of important results, to determine the variations of this species in any given region, and the environmental conditions of each. In such a study, great care should be taken to determine the identity or otherwise of the varieties found with those previously described, not only in order to avoid giving useless names, but also for the purpose of learning, as far as possible, the geographical distribution of the varieties.
- Mesilla, New Mexico, U.S.A.

## ARMATURE OF HELICOID LANDSHELLS

WITH NEW SPECIES OF PLECTOPYLIS.

BY G. K. GUDE, F.Z.S.

(Continued from page 171.)

*PLECTOPYLIS serena* (figs. 65*a-d*), from Si-lin, in the Chinese province Kouang-Si, was described by Mr. Heude in the "Journal de Conchyliologie," xxxvii. (1889), p. 226, and figured in the third part of his "Notes sur les Mollusques terrestres de la Vallée du Fleuve bleu" (1890), t. 38, f. 6. Not having been able to obtain a specimen of this shell, I have been obliged to rely upon Mr. Heude's description and to copy his figures. The shell is described as dextral, discoid, greenish horn-coloured, striated above, shining below, and widely umbilicated, with the spire flattened and the apex scarcely raised. There are six rounded whorls, which increase regularly, the last scarcely descending in front; the aperture is semi-lunate and strongly oblique; the peristome narrow and reflexed; the margins are united by a raised flexuous ridge on the parietal wall, and there is an entering horizontal fold. The parietal armature consists of a single vertical plate, which appears to be a little deflected anteriorly below (see fig. 65*d*). The palatal armature, as figured, appears to consist of six oblique folds, although the author only mentions four in his diagnosis; the first fold is minute, situate near the upper suture, the next four stout and oblique, and the sixth thinner and apparently horizontal (see fig. 65*d*). The measurements given are—major diameter,

locality, received by the writer, from Mr. Hugh Fulton, under the name of *Plectopylis leiophis*, proved upon examination to be distinct, and to belong, in fact, to a different group of *Plectopylis*. They represent a species—for which I propose the name

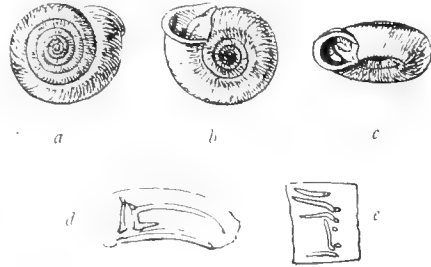
Fig. 66.—*Plectopylis leucochilus*.Fig. 65. *Plectopylis serena* (after Heude).

9 millimetres; minor diameter, 7 millimetres; altitude, 4 millimetres.

*Plectopylis leucochilus* (?) (figs. 66*a-c*). Five shells, labelled "Burma," without further indication of

(1) *Plectopylis leucochilus*, n. sp. (figs. 66*a-c*).—Shell dextral, rather solid discoid, deeply and perspective umbilicated, pale yellowish-corneous, finely and regularly ribbed, ornamented with minute spiral sculpture. Suture almost linear, spire depressed, apex scarcely raised. Whorls seven to seven and a half, a little rounded above, rather tumid below, increasing slowly and regularly, the last descending anteriorly and rather deeply in front. Aperture roundly oval, peristome white, a little thickened and strongly reflexed; the margins a little converging; parietal radius with a slightly raised flexuous ridge, separated from both margins of the peristome by a little notch. Umbilicus deep, widely perspective. Parietal wall

*Plectopylis leucochilus*—allied to *P. ponsonbyi*, but differing from it in the more raised spire and in having a deeper and more perspective umbilicus. In the armature this new species differs from the other members of the group of *P. ponsonbyi* in having the upper parietal fold uninterrupted. Figs. 66*a-c* show the shell in three different aspects, natural size, while figs. 66*d* and *e* are enlarged; the former shows the parietal wall with its plates and folds, and the latter the inside of the outer wall with the folds and denticles.

*Plectopylis ferrierae* (?) (figs. 67*a-f*).—Two specimens of an undescribed *Plectopylis* have been

with two transverse oblique plates converging upwards, the posterior one rather thin, slightly sinuous, and having a short ridge posteriorly at the upper and lower extremities, the anterior one shorter, but much stronger and stouter, having an ascending ridge posteriorly above and a short stout support posteriorly below; on the anterior side are found two strong horizontal folds, the lower stout and short and becoming suddenly attenuated; the upper fold long, rather thinner, following the deflection of the last whorl and terminating close to the ridge at the aperture, but not being united to it; a very thin horizontal fold rises below the transverse plates close to the lower suture, runs parallel with it, and terminates at the ridge at the aperture. Palatal folds, five: the first near the suture, straight and nearly horizontal; the second a little more oblique and deflected posteriorly; the third nearly horizontal, but more deflected posteriorly; all three have a slight indentation near the posterior extremity forming a head-like termination; the fourth is vertical, deflected a little anteriorly above and posteriorly below, having posteriorly a small denticle near the lower extremity and another about the middle; the fifth is near the lower suture, horizontal and deflected at both extremities. Major diameter, 15-17 millimetres; minor diameter, 12-14 millimetres; altitude, 6-7 millimetres. Habitat, Burma. Type in my collection.

(2) *Plectopylis ferrierae*, n. sp. (figs. 67*a-f*). Shell dextral, discoid, widely and deeply umbilicated, pale corneous, very finely and regularly striated, and decussated by spiral lines. Suture slightly impressed, spire flattened, apex a little raised, whorls six to seven, increasing slowly and regularly, flattened above, rounded below, the last angulated above the periphery

obligingly placed in my hands by Miss Linter, at whose request I name it after her friend, Mrs.



Fig. 67.—*Plectophylis perrieri*.

Lumley Perrier. In contour this new species resembles *Plectophylis parvella* (*ante* vol. iii. page 155, fig. 19), but the shell is much larger. The parietal armature further connects it with the species just named, but the palatal armature is more like that of *P. leiophis*. The two specimens of the new species are stated by Miss Linter to be from Thayet-Mayo, Pegu, Burma; a third specimen, which is in Miss Linter's collection, is accompanied by a label bearing the locality, Niningo (Burma?), but I have failed to trace this name in any of the maps and gazetteers to which I have access.

The specimen figured, and the one in Miss Linter's collection, have the measurements given in the diagnosis, but my second specimen measures only 12.5 millimetres in diameter. Figs. 67a-c show the shell in three different aspects, natural size; figs. 67d-f, are enlarged; d, shows the

and round the umbilicus, and descending shortly and abruptly in front. Aperture heart-shaped; peristome white, scarcely thickened, a little reflected; the margins united by an elevated sinuous ridge on the parietal callus, notched at the lower junction. Umbilicus wide and deep. Parietal wall with a thin vertical plate, strongly deflected posteriorly below, and giving off a short horizontal ridge at the upper extremity on each side; a long horizontal flexuous fold rises close to the upper extremity of this plate on the anterior side, descending suddenly at first, then ascending gradually, and afterwards gradually descending, following the deflection of the last whorl, becoming united to the ridge at the aperture; a second, shorter, horizontal fold occurs below this one, rising close to the lower extremity of the vertical plate, proceeding horizontally at first, and then ascending a little; another very thin fold rises below the vertical plate, running parallel to the lower suture as far as the aperture, where it unites with the ridge. Palatal folds, five: the first, rather long and thin, near to and parallel with the suture, with a deep indentation near the posterior extremity, dividing it into two unequal parts; the second, horizontal, a little deflected posteriorly, with an elongated denticle posteriorly, and a second, smaller, one above the first; the third fold much shorter, strongly curved downwards posteriorly, with a minute denticle posteriorly; the fourth fold vertical with an obliquely descending ridge posteriorly at the upper extremity, and bifurcated at the lower extremity, the anterior arm of the bifurcation the shorter; a minute denticle occurs near the ridge at the upper extremity and a second one near the middle, both on the posterior side; the fifth fold is thin, horizontal, and strongly deflected on both sides.—Major diameter, 15 millimetres; minor diameter, 12 millimetres; altitude, 5 millimetres.—Habitat, Thayet-Mayo, Pegu, Burma.—Type in my collection.

parietal and palatal armatures from the posterior side; e, the inside of the outer wall with the palatal folds and denticles; and f, the parietal wall with its plate and folds.

(To be continued.)

## ROYAL INSTITUTION.

THE following Lecture arrangements before Easter are:—Professor Oliver Lodge, six Christmas lectures (specially adapted for young people) on "The Principles of the Electric Telegraph"; Professor E. Ray Lankester, eleven lectures on "The Simplest Living Things"; Professor Dewar, three lectures on "The Halogen Group of Elements"; Dr. J. Paul Richter, three lectures on "Some Italian Pictures at the National Gallery"; Professor J. A. Fleming, five lectures on "Recent Researches in Magnetism and Diamagnetism"; Professor Patrick Geddes, three lectures on "Cyprus"; Mr. Wm. H. Hadow, three lectures on "The Structure of Instrumental Music"; Mr. Lionel Cust, two lectures on "Portraits as Historical Documents, Portraits as Monuments." The Friday evening meetings will begin on January 21st, when a discourse will be given by the Right Hon. Sir John Lubbock, Bart., M.P., on "Buds and Stipules"; succeeding discourses will probably be given by Professor C. Lloyd Morgan, Mr. A. A. Campbell Swinton, Dr. J. Hall Gladstone, Professor L. C. Miall, Captain Abney, Professor J. E. Thorpe, Mr. James Mansergh, the Dean of Canterbury, Professor Dewar, and other gentlemen.

## THE DENTON COLLECTION.

THERE is at present on view in Mr. Robert Dunthorne's "Rembrandt Gallery," 5, Vigo Street, London, a very beautiful collection of most perfect specimens of butterflies and moths, chiefly of extra-British origin. It is not claimed by Mr. Shelley W. Denton, the originator of this exhibition, that it has any scientific pretensions. The novelty is in the manner of mounting the specimens, which, though unpinned, are set out somewhat like the ordinary spreading adopted by collectors of lepidoptera. Each specimen is put in a separate little glass-covered case, backed by a Denton patent tablet, which has a surface hollowed out in the middle, made of very fine plaster of Paris. This system is not one which will appeal to students who desire to handle their specimens in examination, as it only permits of one side of the insect being seen. As a thing of beauty such a collection as Mr. Denton's would be hard to match, and we can strongly recommend our readers who have not seen this system to take this opportunity. There are about 1,500 cases on view.



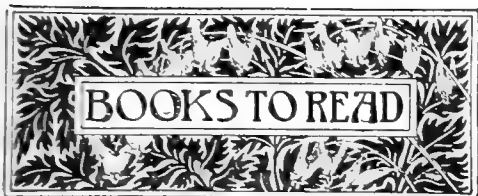

NOTICES BY JOHN T. CARRINGTON.

*The Journals of Walter White*, with a Preface by William White, 293 pp. 8vo. Illustrated by a photogravure portrait. (London: Chapman and Hall, Ltd., 1898.) 6s.

Walter White was a well-known and respected official of the Royal Society. In 1844 he joined the society as sub-librarian, and ten years later became its assistant secretary, finally retiring in 1885. From that standpoint it was Walter White's privilege to meet almost every scientific worthy of the Victorian era. Other men also crop up in his

journal from time to time, such as Tennyson, Spencer Walpole, Carlyle and Gladstone. It is not by any means a learned journal, but a series of gossipy passing impressions of men and events. We suspect, however, in editing these entries, the author's brother has bowdlerized to some extent, as they often show considerable feebleness and are out of character with others. Walter White was the son of

a cabinet-maker, and was brought up to the same trade. The earlier entries in these journals refer to his mixed physical and mental work—the carpenter's bench and the self-instruction through "Chamber's Journal" and the "Penny Magazine." On March 6th, 1833, at the age of twenty-two years, he wrote: "Made deal picture-frames, finished loo table, and began two basin stands. Working late in evening, began chest of drawers. Read Latin." Ten days later we find, "Rained fast on coming out of chapel. Mem: very vulgar to run home." It is interesting to trace through these daily impressions, the steady rise, step by step, until we find him a fluent reader of the French and German languages, and the trusted companion of Tennyson, who, on his advice, purchased the Haslemere property. The latter third of these pages is full of entertaining gossip. "July 6th, 1849. With Macmillan [the publisher]. Home to his house at Balham to dine; an impromptu visit. Talked about a scientific periodical which Lockyer is to edit for him; about Tennyson's transfer of agency to Strahan. He, Mac, offered the Laureate £3,000 a year.

Then, while smoking, he, Macmillan, talked of his father and mother, his early days and struggles—surgeon's assistant, sailor before the mast, teacher and schoolmaster, and last, bookseller." We need hardly add that the scientific periodical was our valued contemporary, "Nature." After nearly forty years, and knowing the enormous change in scientific thought which has taken place since the appearance of Charles Darwin's "Origin of Species," the notes of conversations with Darwin and other leaders of science of the time of its publication are of special interest. We refrain from quoting only on account of the limits of our space. The diary closes in the autumn of 1884, and he retired from the service of the Royal Society in the following year, in consequence of rheumatism in his right hand making writing impossible. The society permitted him to enjoy his full salary to the end of his life, which closed on the 18th July, 1893, in his 82nd year. We feel sure that in his discretion the editor of this journal, as represented in the book before us, has probably exercised wise judgment in respect to the feelings of persons

still living, in cutting out much that was written in the original. We hope, however, the time will come when another and fuller edition will give us a further insight into the unpublished opinions and privately-expressed thoughts of some of the greatest scientific and literary men of the middle of this century.



STRATFORD-ON-AVON.

From "The Shakespearian Guide to Stratford-on-Avon."

*The Shakespearian Guide to Stratford-on-Avon*

By H. SNOWDEN

WARD and CATHERINE WEED WARD. 137 pp. 8vo, with 31 illustrations. (London: Dawburn and Ward, Limited, 1897.) 1s.

We think highly of this little work, which, though a guide in name, is really an interesting miniature treatise upon Shakespearland. The authors tell their story pleasantly enough, and have produced a literary companion for the wanderer in places where Shakespeare was born, roamed as a youth, and later, retired and died. This guide is an instance of work which may be done by amateurs possessed of a camera and artistic taste. To wander round places made sacred by the association of some well-known writer—taking views and writing intelligent notes—is a charming way of spending a holiday. These snap-shot pictures, when printed, form pleasant winter occupation in forming a MS. book, not necessarily for publication. In that way might not some of our entomologists illustrate the fashionable collecting-grounds such as the New Forest, and others equally well known? The Wards have not depended only on their photographic work, but have secured the assistance of Mr. W. T. Whitehead for some of their

illustrations, who has made sketches from their photographs. We reproduce one of these as an example of his line pictures; there are others direct from the photographic prints, each occupying a whole page.

*The Lepidoptera of the British Islands.* Vol. iv. Heterocera, Noctuae. 404 pp. large 8vo. By CHARLES G. BARRETT, F.E.S. (London: L. Reeve and Co., 1897.) 12s.

This volume commences with the species *Axylia putris*, and concludes with *Apamea ophiogramma*. The very full notes of the habits, in the various stages of life, of the species under review by Mr. Barrett, will be found most useful to British lepidopterists, who, with the aid of these volumes and the edition with coloured plates, should have little difficulty in studying the species and life-histories of British butterflies and moths.

*William Harvey.* By D'ARCY POWER, F.S.A., F.R.C.S. 283 pp. 8vo, with reproduced portrait from Hall's engraving of Cornelius Jonson's well-known picture, and 2 plates. (London: T. Fisher Unwin, 1897.) 3s. 6d.

This is another, the second, of the "Masters of Medicine" Series edited by Dr. Ernest Hart. Harvey, living as he did from 1578 to 1657, belonged, as it were, to the dark ages of medicine, when its higher intellects were struggling to lift their profession to an exact science. The life of Harvey has been so frequently written that Mr. Power has done wisely, as stated in his preface, to have re-examined the records during the period of Harvey's connection with the University of Padua. Altogether the author has produced a pleasing biographical story. It is believed that young Harvey received his early education at Folkestone. He afterwards was entered as pensioner or student at Caius College, Cambridge, he being then sixteen years old. In 1598 Harvey appears to have attached himself to the University of Padua, though there is no record of his work in the archives before 1600. It was at Padua that Harvey became not only the pupil but the friend of the celebrated Hieronymus Fabricius, who founded in his mind those qualities which enabled him to follow up the work of that eminent anatomist—work which led to the foundation of Harvey's world-wide reputation as the discoverer of the circulation of the blood in animals.

*Geology of Indiana: Twenty-First Annual Report of the Department of Geology and Natural Resources.* By W. S. BLATCHLEY, State Geologist. 727 pp. medium 8vo, with 39 plates and 6 maps. (Indianapolis: W. B. Burford, 1897.)

As a field for practical geologists to show the value of the science in developing the natural resources of a country, the State of Indiana has few equals. Within the past twenty years this science has raised the State from being a purely agricultural region to a high condition of commercial prosperity. Petroleum has had much to do with this result. Bitumen in its solid, liquid or gaseous forms, has been found in immense quantities, and, as natural gas and petroleum, is now largely worked. One section of this report is devoted to this group of minerals. Another and interesting chapter is on the gigantic Indiana caves and their fauna. Other portions of the book will be found of value to palaeontologists and petrologists.

*With Nature and a Camera.* By RICHARD KEARTON, F.Z.S. 382 pp. medium 8vo, with 180 pictures from photographs by CHERRY KEARTON. (London, Paris and Melbourne: Cassell and Co., Limited, 1897.) 21s.

The Brothers Kearton have produced another beautiful book. It will be remembered that we noticed one of theirs on "British Birds' Nests" (SCIENCE-GOSSIP, N.S., vol. ii. p. 242) in November, 1895. This volume is uniform in size and, to some extent, is a sequel to that one. In our notice we expressed a wish that Mr. Richard Kearton would give us more of his notes, for they could not fail to recount not only natural history but also adventure. This wish has been gratified, and we have before us a most readable book with many clever illustrations. Birds, as before, take the leading place among the observations of these talented travellers; but other matters of much interest are also there. The first three chapters are occupied with a bright and carefully-written account of a visit to the far outlying St. Kilda. The next is on "Gamekeepers, their Friends and Foes." Chapter v. is on "Nests, Eggs and Young"; followed by others on "Where Birds Sleep," "Sea Birds and their Haunts," "How Cage Birds are Caught on the Brighton Downs," "The Art of Duck Decoying," "People we have met," and "Our Methods of Photography." In their investigations, as stated in the preface, our authors "have slept for nights together in empty houses and old ruins, descended beetling cliffs, swum to isolated rocks, laid in wet heather for hours at a stretch, tramped weary miles in the dark, spent nights in the open air on lonely islands and solitary moors, endured the pangs of hunger and thirst, and the torturing stings of insects, waited for days together for a single picture, and been nearly drowned both figuratively and literally; yet such is the fascination of our subject that we have endured all these and other inconveniences with the utmost cheerfulness." We may be asked, who or of what class are these men who have suffered such for the sake of observing and portraying nature at her wildest? They represent a type by no means uncommon among amateur biologists, men who have to earn their daily bread in the great city, and have no more spare time than is afforded during the conventional holidays of such people. It is, however, from that class—the upper clerks and managers of commercial establishments—from which most of our best naturalists are drawn. Their work is usually far more productive than that of the professional man of science, or the man of leisure living in rural districts. The reason is, that the man of limited leisure carefully maps out every day of his holidays long beforehand, for fear any of the precious time may be wasted. Consequently he certainly carries out in his annual fortnight or month, what one of the other classes always intends to do "to-morrow." The aphorism that an Englishman "does not know when he is beaten," applies quite as much to our naturalists as to the heroes who waste their own or others' lives on the field of war. In our long experience we have known many a humble biologist, humble in every sense, whether socially or scientifically, who has done deeds which in themselves were as brave, and required far more consideration at the moment, as others which on the field of battle have gained highly-valued recognition. For endurance, commend to us a really enthusiastic naturalist, perhaps some workman in a factory, who, after a long and

fatiguing day, will walk his twenty miles that he may see a rare insect or plant. Unfortunately, many of these have no one to direct their studies, nor opportunities of allowing others to share the pleasures their pains bring, as in the case of the authors of the work before us. We congratulate them, for can we not, in such a work as this, follow them through their adventures and dangers, and see the localities portrayed in their pictures, spots we have longed to see? Every page shows

fully, we soon feel wonder at the patience, judgment and pains which must have been expended upon their achievement. As stated by the writer of this work, "the best pictures seem to have a fatal knack of slipping from the grasp of the natural-history photographer. The man who essays the task of photographing a wild bird in its native haunts, for instance, soon begins to think that, if he has not succeeded in solving the mystery of perpetual motion, he has discovered a creature



DESCENDING A BIG CLIFF  
From *With Nature and a Camera*, by Richard Kearton.

Mr. Richard Kearton to be an acute observer, and whether it be the difference between development of a set of ideas in a noble and that of the town-living author, or the subtle manner, of their surrounding, but by some *unstudied* work, we find the same thoughtful expression in the simple language that gives an *impression* on page after page as his book. Mr. Cherry Kearton's photographs are generally very clever, and in some cases admirable. When we examine them care-

possessing the secret." By the courtesy of the author and the publishers, we reproduce a plate from this book showing Mr. Cherry Kearton descending a big cliff with camera slung to his back. He may be seen at the right-hand corner of the cliff shortly after he had started on his way to make a picture of a nest in an almost inaccessible position. To naturalists generally, and to ornithologists particularly, Messrs. Keartons' work will be a continual source of fascination

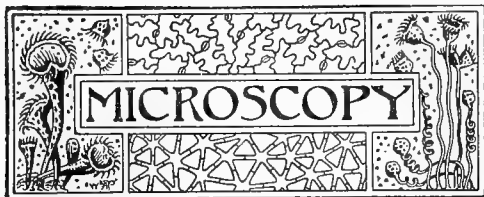

CONDUCTED BY J. H. COOKE, F.L.S., F.G.S.

To whom Notes, Articles and material relating to Microscopy, and intended for SCIENCE-GOSSIP, are, in the first instance, to be sent, addressed "J. H. Cooke, Thorndale, Lincoln."

**THE RINGS AND BRUSHES OF CRYSTALS.**—Those who are possessed of a polariscope as an accessory to their microscope might as well do a little physics, and employ it in the observation of that beautiful and interesting optical phenomenon known as the rings with a cross, or the rings and brushes of crystals. Some treatises on the mounting of microscopic objects give directions for the cutting of these crystal sections; but the methods of observing them under the microscope are seldom described and, I believe, are rarely known, at least among amateurs. The crystals most commonly employed are calcite, Rochelle salt, borax, phosphate of soda, nitre, ferrocyanide of potassium and bichromate of potassium, all of which, except the two last, require to be specially prepared by cutting sections perpendicular to one of their optic axes. Practically it is not always easy to find where the optic axis exactly lies, but I have found by experience that for borax a longitudinal section, for phosphate of soda a transverse, and for Rochelle salt an oblique section, of the respective crystals will furnish the object desired. The sections, taken about a quarter of an inch thick, are smoothed to about one-eighth of an inch thick with water on a hone, taking care that the flat sides are kept strictly parallel. The preparation of calcite requires special manipulation on account of its splintery cleavage; a piece must be slowly cut off by a fine saw (made by fastening a piece of steel ribbon in a groove cut in a wooden stick) at right angles to the long axis of the hexagonal prism, and then cautiously smoothed flat and rather thin on a hone moistened with paraffin. Some selected crystals, on the other hand, such as those of sugar, sulphates of zinc and of magnesia, may be examined without any preparation. All sections as soon as made must be immediately mounted in watchmaker's oil in a glass or tin cell of the requisite depth, and closed with Miller's cement, or best colophony-shellac varnish. Having manufactured as excellent a section as you can possibly manage, *i.e.*, one as nearly vertical to the optic axis as can be hit upon, the next design and endeavour will be to apply the micro-polariscope so as to discover and exhibit its double refraction phenomena efficiently and conveniently. For this purpose it is imperative that the crystal section be examined under convergent polarized light, and that the phenomenon thuswise revealed, and not the image thereof, should be viewed directly by the objective. Now in order that the light polarised by the nicol below the stage be rendered convergent, it is necessary to surmount it by a double-lensed condenser. An achromatic condenser of short focus may be employed, but I have found a doublet composed of a hemispherical lens of five-eighths inch diameter, with a similar lens of five-eighths inch diameter placed above it, to be very

effective and quite sufficient. Proceed now as follows: Place the slide on the stage, and push up this condenser as near as possible to it. Use a quarter-inch objective below the analyser on the nose-piece, and put the nicols in the crossed position, *i.e.*, where there is "no light, but rather darkness, visible." Lower the objective close down so as to touch the cover-glass of the slide, or nearly so, and then remove the eye-piece. The rings and cross of a uniaxial crystal, or the rings and brushes of a biaxial crystal will then be observed with illustrious beauty, and a clearness corresponding to their size and the perfection of their condition. There is a considerable advantage in using a large polarizer, as thereby the field of view is enlarged, and the same effect is produced by having the condenser as strongly convergent as possible. By all means place a biconvex lens of about three inches focus immediately above the analyser on the nose-piece, so as to enlarge the image and render it more distinctly visible.—*Dr. P. Q. Keegan, Patterdale, near Penrith.*

**MOUNTING VOLVOX.**—The best months for obtaining Volvox or Desmids are July and August. Place the gathering in a small tank or a glass tumbler and stand it in a well-lighted window for a few days. The volvoxes will collect on the side nearest the light, and may be readily taken out with a pipette. Place them in a watch-glass containing alcohol, three; distilled water, two; glycerine (sp. gr. 1.250), one. Allow this to stand for a week or two under a glass tumbler, at the end of which period the water and spirit will have evaporated and the algae will be left in pure glycerine. Mount in a cell and ring with asphalt.

**ODONTOPHORES OF SNAILS.**—These serve as excellent objects for the polariscope. To mount them use a weak form of Goadby's solution, and apply just sufficient pressure to open out the ribbon, but not enough to reduce everything to a dead level.

**REFRACTIVE INDICES OF CERTAIN LIQUIDS.**—The following table of refractive indices, taken from a number of the "Scientific American," may be of some value to those of our readers who are experimenting with liquid mediums: water, 1.336; alcohol, 1.372; muriatic acid, 1.410; nitric acid, 1.410; sulphuric acid, 1.434; olive oil, 1.470; oil of turpentine, 1.475; castor oil, 1.490; balsam, copivi, 1.528; Canada-balsam, 1.549; oil of cloves, 1.535; oil of cassia, 1.641; sulphuret of carbon, 1.768.

**DEAD-BLACK VARNISH.**—Methylated spirit, five ounces; orange shellac, a quarter ounce; lamp black, half ounce. Dissolve the shellac in the spirit, then rub the lamp black very fine and add the liquid gradually.

**A FLY'S FOOT.**—The walking of a fly on the ceiling is a familiar phenomenon not yet fully understood. A recent paper by Mr. D. H. Dierhold mentions that the microscope quickly disproves the old theory that flies hold to smooth surfaces by means of suckers, and that Hooke's idea that flies stick to glass by a viscous secretion was shown a dozen years ago to be only partly sound. Dr. Rombout has established the fact that the flies hang on by the help of capillary adhesion—the molecular attraction between solid and liquid bodies. It is true the foot hairs are very minute, but, as each fly is said to have 10,000 or 12,000, we need not be surprised at what they can do.

**CRYSTALLIZATIONS OF FATS.**—Recent investigations demonstrate that the crystalline forms of animal and vegetable fats differ materially. To illustrate this in some degree, we now submit three illustrations, chaumugra fat crystals, crystals of human fat, and the fat crystals of a monkey. To obtain crystals of the fatty glycerides of animal fats, the melted fat should cool gradually for about ten hours in a temperature of about sixty-five degrees Fah., in order to get the fully-developed crystallization. The fat of plants will crystallize within as many minutes. In a paper on this subject by Mr. T. Taylor, and which was published by the Division of Microscopy of the United States Agricultural Department, he details the methods that he adopted in his researches in this direction. For the purpose of securing interesting and beautiful groupings of the crystals of seed fats it is necessary to follow strictly the method outlined, otherwise many of the most beautiful forms will not be obtained. Briefly described, the method is as follows: In preparing chaumugra fat (extracted from the seeds of

**CLEARING OF VEGETABLE MICROSCOPICAL SECTIONS.**—One of the most troublesome processes connected with the staining and mounting of vegetable tissues is the preliminary clearing. In the "Pharmaceutical Journal" Mr. W. Kirby, F.L.S., describes a method of clearing which is at once practical and effective. Clearing agents are of two kinds, namely, those which act by virtue of their property of strongly refracting light, and those which disintegrate and dissolve the obtrusive cell-contents. To the first class belong clove oil, cedar-

wood oil, cajuput oil, xylol, dammar resin, Canada - balsam, glycerine, and other similar bodies; to the second class, solutions of caustic potash, eau de Javelle, eau de Labar- aque, phenol, chloral hydrate, etc. The usefulness of most of these substances is comparatively limited, while some of them are decidedly objectionable for permanent mounts, because of their energetic action upon the tissues. An efficient clearing method should ensure the removal of the cell contents, but should have a minimum effect upon the cell-walls. Without discussing the merits of each of the usual



Chaumugra Fat Crystals.



Human Fat Crystals.



Fat Crystals of Monkey.

## CRYSTALLIZATIONS OF FATS.

*Glyceride mounts for microphotography* put a small portion of it on a microscopical slide, placing over it a glass cover, such as is used in general mounting. Heat the slide over a spirit-lamp until the fat melts, do not overheat and allow it to cool in a temperature of sixty degrees Fah. Within a few minutes the mount will appear white owing to the crystallization of the fat. The slide is now ready for observation under the microscope.

methods adopted for clearing, I may say that in my hands the process I use more nearly fulfils the above conditions than any other I have tried, the sections after treatment being obtained in a condition suitable for putting up in liquid, gelatinous, or resinous mountants. Place the sections in a fresh, clear solution of chlorinated lime, and allow them to remain until quite bleached, say, from two to four or five minutes; gently warm in a test-tube for a few seconds, then quickly

replace the solution with distilled water, and boil for two or three minutes; repeat the treatment with boiled water three times, wash with a one per cent. solution of acetic acid, and finally with cold distilled water. The sections are then quite ready for staining.

**TEST FOR TOLU BALSAM.**—Failures in mounting are often traceable to impurities in the re-agents and materials used. The following test for purity of tolu balsam, as recommended by Gehe, may not be without value to those of our readers who may have occasion to use this mountant. Mix a few grammes of balsam with carbon-disulphide, draw off a few drops of the solution, evaporate, and cover the residue with sulphuric acid. Pure balsam gives an intensely blood-red colour reaction, while mixed colours are indicative of adulteration with resin.

**ACTION OF LIGHT ON YEASTS.**—W. Lohmann, who has recently been giving attention to this subject, finds that exposure to the electric light of more than eleven thousand candle power exerts a decidedly retarding action on the multiplication of the cells of *Saccharomyces cerevisiae*. Observations in the action of sunlight showed that the sun's rays are even more disastrous in their effects, for after several hours' direct exposure during May and June the cells were entirely destroyed. A moderate amount of light produces no such effect, multiplication taking place as vigorously in that case as in the dark. According to "Nature" a microscopic examination revealed a striking morphological difference between cells kept in the dark and others which had been isolated. The former preserved a perfectly normal appearance, but the cells acted upon by the sun's rays looked shrunken, exhibited irregular contours, and the plasma was drawn together in lumps, chiefly in the direction of the poles of the cells.

**ASSIMILATION IN GREEN PLANTS.**—"Nature" reports a new method of demonstrating the assimilation in green plants, which Mr. Francis Darwin recently communicated to the Cambridge Philosophical Society. Farmer has shown that if an *Elodea* leaf be subjected to a stream of hydrogen, and be kept in the dark, its protoplasm ceases to circulate. This stoppage depends on the protoplasm being deprived of oxygen; the reappearance of the movement is a consequence of the fresh supply of oxygen yielded by the chloroplasts in light. This action may be readily observed if two or three *Elodea* leaves be mounted in water and sealed down under a single cover-glass with a preparation of melted wax and paraffin. If the preparation be placed in the dark, the circulation will quickly be affected by the want of oxygen, and at the end of six or seven hours it will cease altogether. It may, however, be restored by exposing to sunlight or to the incandescent gas flame.

**PHOTO-MICROGRAPHY.**—At the last meeting of the Royal Microscopical Society, Dr. H. Stringer explained a novel invention for obtaining photographs of micro-preparations. The apparatus is somewhat complicated in construction, but it works readily and gives most perfect results. During the course of the demonstration he took several negatives of the germ that gives rise to bubonic typhus and also of other bacilli. His demonstration was received with much enthusiasm. In a future issue we hope to be able to give further details of the apparatus.

**HONOURS FOR BRITISH MICROSCOPES.**—The jury of the Brussels International Exhibition of 1897 has awarded to Ross, Limited, 111, New Bond Street, London, a Grand Prix, a Diploma of Honour, and gold, silver and bronze medals for their exhibits of optical instruments.

**MANCHESTER MICROSCOPICAL SOCIETY.**—At the November meeting of this Society, Mr. Mark L. Sykes, F.R.M.S., read an interesting paper on "Natural Selection in the Lepidoptera." After dealing with the principles of natural selection as set forth in Wallace's chart, he gave a number of instances of mimicry in relation to tropical butterflies, specimens of which were shown in his collection, which was exhibited at the meeting. The paper was also illustrated by lantern slides, which had been prepared by Mr. A. Flatters, another member of the Society.

**MOUNTING APHIDES.**—When mounting aphides and other small insects, it will often be found that the specimen has a tendency to curl its legs under its body. This difficulty Mr. G. B. Buckton has, in a measure, overcome, by first placing a few drops of balsam on the glass slide, to which the insect is then transferred by means of a moistened camel's-hair brush. The efforts of the insect to escape will cause it to spread out its legs in a natural position, and a cover-glass may then be placed in position and a drop of balsam placed at the side, when, by capillarity, it will fill the space between the slide and the cover-glass, and the limbs will be found to have remained extended. If three or four drops of the balsam are put on the glass the wings may also be brought down and caught to them so that they will remain expanded in shape for examination.

**SOCIETY TRANSACTIONS.**—We learn from the current issue of the "Transactions of the Edinburgh Field Naturalists' and Microscopical Society" that it is the intention of that society to revive the microscopical section. This section has been dormant for some years, but it was re-started last winter, and, under the able directorship of Mr. W. C. Crawford, M.A., F.R.S.E., it gives every promise of doing useful work in the future. The members of this section were last winter chiefly engaged in working out the seaweeds and their freshwater representatives. In a paper on "Plant Origins," Mr. Crawford briefly indicates the main lines upon which the work should be done. He is careful also to point out that the mere collection, mounting and naming should not be the one end and aim in view. The subject has a philosophy. How these creatures live, why they work, and their relations to the great living cosmos, should all be sought for and reasoned out.

**DIATOMS IN STOMACHS OF OYSTERS.**—The examination of the stomachs of oysters and of other molluscs will, as a rule, well repay the diatomist. The following is Mr. G. Sturt's method. Pick out the stomachs and drop them one by one into a flask which contains, say, five or six ounces of nitric acid that has been heated to boiling-point. When they are all dissolved add an ounce of hydrochloric acid and continue the boiling for five minutes, dropping in at intervals a little bichromate of potash. Fill up the flask with hot water and empty the whole into a large beaker, filling up with hot water. Skim off the fat, wash away the acid, and boil the residue in soap and water. If this does not get rid of all of the organic matter, boil in sulphuric acid and chlorate of potash.



CONDUCTED BY FRANK C. DENNETT.

		Position at Noon.			
	1897.	Rises.	Sets.	R.A.	Dec.
	Jan.	Jan.	Jan.	Jan.	Jan.
Sun	12 ... 12	8 a.m. ... 4 p.m.	11 53 ... 3 54	227 53	22° 54' S.
	12 ... 12	8 4 ... 4 43	11 57 ... 3 56	227 57	21° 56'
	22 ... 22	7 54 ... 4 29	12 0 ... 3 56	228 0	19° 56'
		Rises.	Sets.	Age at Noon.	
	Jan.	Jan.	Jan.	Jan.	
Moon	12 ... 11 55 a.m.	12 50 p.m.	3 8 a.m.	9 16	5
	12 ... 11 51 p.m.	12 46 a.m.	9 57	19 16	5
	22 ... 7 54 a.m.	12 33 p.m.	5 0 p.m.	0 4	35

		Position at Noon.			
	1897.	Rises.	Sets.	R.A.	Dec.
	Jan.	Jan.	Jan.	Jan.	Jan.
Mercury	12 ... 12	11 47 p.m.	4 7	16 32	20° 5' S.
	12 ... 11 47 p.m.	11 47	4 8	16 31	19° 44'
Venus	12 ... 12	11 47	4 8	16 38	20° 59'
	12 ... 11 47	11 47	4 9	16 7	23° 29' S.
	12 ... 11 47	11 47	4 9	16 1	23° 37'
	12 ... 11 47	11 47	4 9	16 15	21° 37'
Mars	12 ... 12	11 47	4 9	16 24	23° 56' S.
Jupiter	12 ... 12	11 47	4 9	16 37	20° 34' S.
	12 ... 11 47	11 47	4 9	16 39	20° 44'
	12 ... 11 47	11 47	4 9	16 43	20° 47'
Saturn	12 ... 12	11 47	4 9	16 59	20° 9' S.
Uranus	12 ... 12	11 47	4 9	16 1	23° 27' S.
Neptune	12 ... 12	11 47	4 9	16 1	23° 27' S.

MOON'S PHASES.

	1897.	Rises.	Sets.	R.A.	Dec.
	Jan.	Jan.	Jan.	Jan.	Jan.
Full	Jan. 12	11 47 a.m.	12 0 p.m.	144	44
New	Jan. 22	7 25 a.m.	12 0 p.m.	29	23

In apogee, January 4th, at 3.54 p.m., distant 252,200 miles; and in perigee on 20th, at 0.36 p.m., distant 221,700 miles.

CONJUNCTIONS OF PLANETS WITH THE MOON:

Jan.	Planet	Time	Position
11	Jupiter	5 p.m.	planet 7° 5' N.
11	Saturn	7	5° 40' N.
11	Mercury*	4	4° 12' N.
21	Mars	2 a.m.	0° 22' N.
21	Venus	9 p.m.	0° 42' S.

\* Below English horizon

OCCULTATIONS:

Star	Planet	Date	Time	Mag.
12	Mars	Jan. 12	12 50 p.m.	1.7
12	Jupiter	Jan. 12	12 50 p.m.	1.7
12	Saturn	Jan. 12	12 50 p.m.	1.7
12	Mercury	Jan. 12	12 50 p.m.	1.7
12	Venus	Jan. 12	12 50 p.m.	1.7

**ECLIPSE OF MOON.**—On January 7th there will be a total eclipse of the moon, wholly visible in 1897, weather permitting. The first contact with the penumbra occurs at 9 11 p.m., and the last contact with the penumbra at 11 55 p.m. The first contact with the umbra occurs 7 9 minutes after midnight, and the penumbra one hour and forty minutes later. Therefore the middle of the eclipse occurs at 11 55 p.m., when the magnitude of the eclipse is 1.7. The moon's diameter is 31'. The first contact with the umbra is from the north point towards the west.

**COMETS.**—On January 2nd, comet *a* was seen at the cone of habitability, the earth being in the equator. It is in latitude 23° 27' N. and longitude 121° 10' W. Its path is from the east to the west, the centre to

the coast, the Indian Ocean, India and Western China. Sir J. N. Lockyer and party will be at Vizidurg; the British Astronomical Association contingent, numbering twenty-six, will be in three parts, at Masur, Buxar on the Ganges, and near Pulgaon; the Astronomer Royal and Professor H. H. Turner will be at, or near, Sobagpur; Dr. Michie Smith, Director of the Government Observatory, Madras, will be at Karad; Dr. Copeland, Astronomer Royal for Scotland, will have his 40-foot telescope at the termination of the Satpura Hills, some fifty miles from Nagpur; Professor Naegamvala, of Poona Observatory, will probably be near Karad; and Mr. Newall and Captain Hills, R.E., at Talmi or Pulgaon. Rev. J. M. Bacon will endeavour to photograph the eclipse with a kinematograph, provided and adjusted by Mr. J. Nevil Maskelyne, having a 3½-inch object-glass of about two feet focus, and taking five photos per second. America, France and Japan are also sending expeditions.

**THE SUN** has continued very quiescent until the end of the first week in December, when an enormous group of spots came round the limb. At 1 p.m., on 2nd January, the earth is at its nearest to the sun.

**MERCURY** is in inferior conjunction on 6th, at 4 p.m., and at the same hour on 29th reaches its greatest elongation, 25° 4' west. On this date it rises one hour twenty-two minutes before the sun, but the great south declination militates against successful observation.

**VENUS** and **MARS** are too close to the sun for observation.

**JUPITER** rises about midnight on 1st, and nearly two hours earlier at the end of the month, its path lying to south-east of  $\gamma$  Virginis.

**SATURN**, about 1° north of  $\omega$  Ophiuchi and 6° north of Antares, early in the month travels eastward, and may be observed before sunrise; also **URANUS**, just south-east of  $\beta$  Scorpii.

**NEPTUNE** is a little south-west of  $\eta$  Tauri, 5th-magnitude, in good position.

**METEORS** may be looked for specially on January 2nd, 21st and 31st.

RED STARS IN POSITION DURING JANUARY:

	R.A.	Dec.	Magni-	
	h.m.		tude.	
$\alpha$ Canis Majoris	6.49	24° 2' S.	± 4.5	Ruddy.
" "	7.9	22° 53' S.	6.5	Flery red.
$\beta$ 175 "	7.18	25° 31' S.	7	
22 "	6.58	27° 47' S.	3.5	Fine red
15 "	6.59	26° 0' S.	± 5	Var. in colour (?)
$\sigma$ Geminorum...	7.28	29° 10' N.	± 5	Ruddy.

**COMETS a AND b, 1897.**—It appears that the recently discovered comet was really *b*, 1897, comet *a* being D'Arrest's, first seen by Mr. Perrine on June 28th.

**OCCULTATION OF CERES.**—On November 13th, Dr. Schorr, at Hamburg, and Professor Harzer, at Kiel, both observed the egress. The planet did not, like a star, burst into full brightness, but increased gradually during one or two seconds.

**THE LEONIDS,** it appears, were only seen by some bakers on their way to work on the morning of November 15th, shortly before daybreak; so reports "The Dumfries and Galloway Standard." Continental and American observers were as unfortunate as the British.





A SKELETON of the moa was recently sold at Mr. J. C. Stevens' auction rooms, Covent Garden, the price reached being forty-eight guineas. Captain F. W. Hutton, F.R.S., set up the bird from bones obtained at Enfield, New Zealand.

At the Geological Congress to be held at St. Petersburg, Professor Androussow will propose, with the unanimous approbation of his assistants, to make an international floating geological station for the study of the geology of the bottom of the sea, and of marine sedimentation.

OUR readers will find in the December "Irish Naturalist" an interesting account of two natural history excursions to the outlying islet of Rockall, in the Atlantic. It is from the diary of Mr. R. Lloyd Praeger, B.E., and, although a landing was not effected on either occasion, the article is most readable.

At the last meeting of the Biological Society of Washington, Dr. M. G. Motter presented a paper on "Underground Zoology," the result of careful examination of several disinterred human bodies, with a view to discover the species of animals, and especially insects, present, in order to test Megnin's "Application of Entomology to Legal Medicine."

LOVERS of nature will hear with pleasure that the preservation is announced of the celebrated Lofty Down Rise, above Ventnor, Isle of Wight. The estate, which comprises several hundred acres of downs on the highest land in the island, has been presented by the owner, Mrs. Evans, to the town of Ventnor, for the use of public recreation.

A MEETING of teachers of botany and zoology was held on November 30th at the Linnean Society's rooms to protest against the new regulations for the Intermediate Science Examination of London University, in so far as candidates are to be allowed, from 1899, the choice of any three of the following four subjects, viz., (a) Mathematics, (b) Chemistry, (c) Physics, (d) Botany *plus* Zoology.

It is very properly felt that this arrangement would have the effect of practically barring the section *d*; as candidates to pass successfully in it will have to prepare themselves in two distinct subjects, instead of one as in each of the former sections. It is the more surprising that these subjects should have been bracketed, when they are fully recognised in every science school as separate branches of knowledge, taught in separate laboratories by separate teachers, and tested by separate papers for examination.

A MEMORIAL has been sent round for signature, which we have gladly signed, drawing the attention of the Senate of the University of London to the urgent necessity of amending forthwith the new regulations above referred to, "as the result will clearly hinder the progress of botanical and zoological science throughout the country, and will prejudice London graduates in the competition for teaching and other posts."

THE new Potsdam refractor, when finished, will be the largest in Europe, its aperture probably reaching nearly thirty-two inches.

THE Catholic University of America has just lost the director of its astronomical observatory, by the resignation of Dr. Searle, who is succeeded by Mr. Alfred Doolittle.

MR. ERNEST SWINHOE, of Avenue House, Oxford, has issued his priced catalogue, for 1898, of Indian, African and American butterflies and moths. It includes upwards of two thousand species.

THE naturalists, especially the botanists, of Cape Colony have lost by death Mr. Leopold Marquand, C.M.G., an authority on ferns, and a kindred spirit in other branches of natural science. He had been Surveyor-General of the colony where he was born. His celebrated private ferneries in Cape Town were one of the sights of the city.

WE hear from a correspondent that several cormorants have been shot on Ullswater in the act of diving for trout. In fact one bird had one of these fish, weighing over half-a-pound, in its mouth when obtained. It is estimated by local anglers that a full-grown cormorant will consume seven pounds weight of trout every day during their unwelcome visits to the lakes.

MESSRS. LOVELL, REEVE AND Co. are about to publish a series of "Monographs of the Genera of Lepidoptera," at a net price of 7s. 6d. per part. Each of the twenty-four monthly parts will be an independent work. The first is by Miss E. M. Bowdler-Sharpe, on the genus *Teracolus*, and the illustrations of all the known species of the genus will be by Miss Maud Horman-Fisher.

WE observe from the last report of the Clerkenwell Free Library that the science of Biology is popular among its readers. During the eight years the Library has been open sixty-eight works on Biology have been issued over 2,800 times. These include books on Evolution and the methods of scientific research. Two copies of Darwin's "Descent of Man" have been issued over 200 times, or equal to the most popular novels. Clerkenwell is largely a workman's district, and generally considered "rough."

MR. PASSMORE EDWARDS has offered to build a Museum at West Ham, adjoining the Technical Institute, to contain the collections of the Essex Field Club. The conditions are that the Museum be maintained by the Corporation of that town, as a permanent Institution, and that it is open on Sundays. The Museum is intended to illustrate the county of Essex generally. The small museum in Queen Elizabeth's Lodge, near Chingford, at present containing the Essex Club's collections, will be confined to objects from Epping Forest.

PRESTON SCIENTIFIC SOCIETY is now installed in its new abode, which has been redecorated and furnished by the Society. The rooms were previously occupied by the museum, and have been granted to the Society, at a nominal rental, by the Town Council. The Society numbers about 520 members, including many of the scientific leaders of North Lancashire. It is divided into sections devoted to astronomy, botany, geology, microscopy, natural history and photography, which hold independent meetings, though affiliated under the general council.





CONTRIBUTED BY FLORA WINSTONE.

**LE MONITEUR SCIENTIFIQUE** (Paris, December, 1897).—This number contains the index for the year, which appears very ample. MM. G. Lunge and C. Millberg contribute an article on "The action of Caustic Alkalis and Carbonate Alkalis upon different modifications of Silicate Acids." M. Gerber concludes his notes on "Recent Studies of Natural and Artificial Essences and Perfumes." There are also extended reports of the meetings of the Academy of Sciences.

**TERMÉSZETRAJZI FÜZETEK** (Budapest, November, 1897). The first article in this number is by Professor Anton Koch on "*Psychiaca don orientalis*." It is illustrated by two magnificent plates, which, as is usual in this publication, are bound with others at the end. Herr A. Carolo Emery gives an account of some new species of Formicidae, and some little known, which are in the collection in the Hungarian National Museum, and were collected by Herr L. Biró from the German Colony in New Guinea. Fifty-four species are described, of which forty-nine are new. Two plates and one figure illustrate this article. Dr. G. Horváth describes thirty-five new species of Homoptera from Hungary, illustrated by five figures, and Herr Alexandro Mocsáry describes five species of Hymenoptera new to the fauna of Hungary.

**LA FEUILLE DES JEUNES NATURALISTES** (Paris, November, 1897).—M. Caziot commences a series of articles on "Prehistoric and Archaeological Discoveries made in Corsica in 1897." The writer proposes, in the course of his articles, to reproduce photographs of many interesting objects of prehistoric interest which have been discovered in this island by Captain Ferton, M. Malespina, and M. Guidone Franceschi de Poggio. The specimens have in most instances been presented to M. A. de Mortillet for identification. M. Eugene Simon continues his series on the "Revision of the Genera of the Trochilidés" (December). The first article is by M. Gustave F. Dolfus. It is geological, and is a "Discussion upon the foundation of the Chloritic Marl Stratum." In this number the writer deals chiefly with the strata of the Isle of Wight, taken at Ventnor, Dorset, at Swanage; Devon, at Pinhay, Lyme Regis.

**L'INTERMÉDIAIRE DES BIOLOGISTES** (Paris, November 20th, 1897).—This is the second number of a new magazine intended to be an international organ of zoology, botany, physiology and psychology. It is edited by M. Alfred Binet, D.Sc., and Director of the Psychological and Physiological Laboratories of the Sorbonne. The assistant-editor is M. Victor Henry, Director of Philosophy. The object of the magazine, as stated in the programme, is to furnish to biologists of all countries a means of constant communication and also to publish researches and theories without attaching itself to any particular school. It is further proposed in each number to give in order any questions which may

be sent with regard to scientific problems, and in the next number, or as soon after as possible, to give the answers as sent by readers. In this number M. E. Gley contributes a memorial notice of Rudolf P. Heidehain, the well-known German physiologist. The rest of the magazine is occupied by questions, with the replies to those that appeared in the first number, and the contents of some of the German, French and English periodicals on zoology, botany, physiology and psychology. It is a fortnightly magazine, price sixty centimes.

**COSMOS** (Paris, December 4th, 1897).—Dr. L. Menard continues a series of articles on "The Emotions," treated physiologically. In this number he deals with "Temper." Passion, he says, is produced by an excess of innervation of the voluntary muscles. The nerves conforming to the general feeling are obliged to defend themselves. Cries, or a loud voice, violent movements, and disordered expression, are thus produced. Joy has some of the same symptoms, but in a less degree. The effects were also produced in certain irritable subjects who have been charged with electricity by a doctor. "Irritability of Temper," adds Dr. Menard, is not at all a sign of strength or energy. He points out also what very close relation there is between the physical and moral nature of man. M. A. Berthier commences an illustrated series of articles on "New Motors," beginning with Schmidt's Vapour Motors. There is a long description by M. Albert Battandier, of "Vital Magnetism." He gives a short history of hypnotism from its first known use, and an exhaustive analysis of the five theories in general acceptance. The first, he says, is generally held by certain superstitious persons who, having only superficially examined the subject, maintain that it is the work of the devil. The others are spiritualism and the scientific group, which hold three hypotheses: (1) The school of Paris; (2) Of Bernheim; (3) Animal magnetism. M. Tisserand writes on the "Proper Movement of the Solar System." The current article is on "The Proper Movement of the Stars," and is divided into—(1) Historical; (2) An account of the most remarkable movements; (3) The proper movement of the solar system; (4) Works of M. Herschel and his successors. This is one of a series, and will be continued in the next number.

**TRANSACTIONS ACADEMY OF SCIENCE** (St. Louis, U.S.A., November 30th, 1897).—This is No. 18, vol. vii. of these "Transactions." It is occupied by a paper by Prof. William Trelease, the eminent botanist. The subject is "An Unusual Phyto-Bezoar." In January last the author received from Mexico some specimens of surprisingly symmetrical round, smooth balls, measuring three or four inches in diameter, and weighing about half a pound each, which were taken from the stomach of a wild bull. In the same stomach, there were sixteen of such balls. They were of a brown colour, and in appearance like rubbed sole leather. They were composed of the barbed indigestible hairs of cacti of the *Platopuntias* group, or prickly pears. The bars enable these hairs to felt together in the stomach of the beast, by aid of the visceral movements. This cause of death is by no means unusual among ruminants, and has even been observed in human beings, but we are not aware that cacti have been previously noted as the origin, though largely eaten by both tame and wild cattle in Mexico.

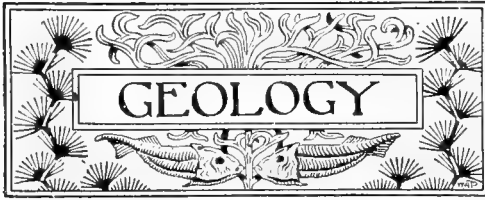

CONDUCTED BY EDWARD A. MARTIN, F.G.S.

To whom all Notes, Articles and material relating to Geology, and intended for SCIENCE-GOSSIP, are, in the first instance, to be addressed at 69, Bensham Manor Road, Thornton Heath.

As a result of the decomposition of organic substances, "homus" becomes charged with what are known as the homus acids (crenic, opocrenic, ulmic, etc.), and these acting upon a subsoil of limestone, such as chalk, cause its disintegration, and it is probably owing to their action that the surface of the chalk is so often seen to be broken by holes like inverted cones, filled with rubble resulting from the destruction of the chalk. The irregularity of the surface would be owing to the rock yielding to the solvent acids in different degrees in different places.

A. J. JUKES-BROWNE has pointed out, in describing the geology of the town of Devizes before the Geologists' Association, a peculiarity in the Lower Chalk, which here rests upon six or seven feet of passage-beds or chloritic marl. Under the microscope the carbonate of lime is seen to be accompanied by minute discs and globules of silica, together with silicious spicules of sponges. It includes mineral (? quartz) particles, glauconitic grains, fragments of shells (silica), cavities filled with silica and residuary spicules. At Eastcott it contains hard cherty nodules, which may be regarded as imperfectly formed flints.

No one who has collected fossils from the gault can have failed to notice that many of them have become wholly pyritised. Large lumps of pyrites can also be easily obtained which bear no resemblance to fossil forms at all. Roft says that pyrites is formed by the conversion of sulphate of iron into the sulphide by organic matter, and also from "traces of ferrous carbonate, mixed with sulphates of the alkalis and alkaline earths, in the presence of organic substances. Its formation is still to be observed in peat-bogs, in deposits from mineral springs, from waters of mines containing sulphate of iron, and from sea-water, where the coasts furnish soluble iron compounds." The decomposing animal matter in the shells would give rise to organic acids which would reduce a sulphate by removing its oxygen, and deposit a sulphide of iron, in many cases even removing the calcite of the shell itself, and replacing it molecule by molecule by pyrites.

FOREIGN BOULDERS IN CHALK.—The discovery of boulders and pebbles of granite, green schist, and quartz in the Chalk at various times, has always excited considerable interest. Probably such discoveries are not really rare, but the stones found are distributed amongst numerous private collections. In 1857 the famous "Purley boulder" was discovered in Haling Pit, South Croydon. This was composed of syenite, and weighed nearly forty pounds. It was accompanied in the matrix by pebbles and fine sand, and owing to its weight its carriage across the cretaceous sea is not thought to be explicable except by the agency of floating

ice. Other boulders of smaller size have since been excavated from the Chalk, the neighbourhood of Norwich having yielded various specimens. Among those more recently discovered are two which were obtained from the Middle Chalk of Betchworth, in Surrey, by Mr. W. P. D. Stebbing, F.G.S. The two boulders in question were of granite, although different in character, and were both very much weathered. They weighed 7 lbs. 7 oz. and 3 lbs. 12 oz. respectively, and measured, the one 5.8 in. × 6.25 in. × 4.125 in., and the other, 3.6 in. × 5.8 in. × 4.5 in. The transportation of these boulders, which Professor Bonney judged might be of Scandinavian origin, was attributable to one of four causes: by adhesion to seaweed, driftwood, by marine animals, or ice. It was particularly interesting to notice that to the largest, valves of *Spondylus latus* and *Serpula*, were still attached. In the presence of these and other larger boulders in the Chalk, we have undoubted evidence that the sea in which was laid down the Middle Chalk was occasionally traversed by stray icebergs.

PERMANENCE OF OCEAN BASINS.—Amongst the many preconceived notions which have in recent years been abandoned by modern geologists is the opinion that our ocean-beds have in former geological times formed portions of continental areas, and the theory has gained ground that although the boundary lines have shifted their positions very considerably, yet, in the main, where there are oceans now, there have always, more or less, been oceanic areas. But there is a tendency in this also to go to extremes. Dr. Blandford remarked seven years ago, that "whilst the general permanence of ocean-basins and continental areas cannot be said to be established on anything like proof, the general evidence in favour of this view is very strong." Some land areas, on the other hand, have within comparatively recent times been submerged beneath more than a thousand fathoms of water, whilst "sea-bottoms, now over a thousand feet deep, must have been land in part of the Tertiary era." Besides, there is every evidence to prove that there have been formerly land connections across what are now broad and deep oceans.

GEOLOGISTS will probably for a very long time continue to inveigh against the indefensible titles which characterise the formations known as the Upper and Lower Greensands. When Webster proposed the terms in 1824, he little knew how great a trouble they would be to geologists in the future. Green sand the Lower Greensand seldom is, and Godwin-Austen, in 1850, proposed for it the French equivalent title, namely "Neocomian," although it is now found the Neocomian is the equivalent of our Wealden, the "Aptian" being that of the Lower Greensand. "Vectian" has since been proposed by Jukes-Browne, and has everything in favour of its adoption, except popular use. So far as the Upper Greensand is concerned, any name which is proposed for it must include also the Gault clay, since the latter is now recognised as being merely a deep-sea equivalent of the former. Fitton proposed, in 1824, the name of "Merstham Beds." In 1892 Jukes-Browne proposed "Devisian" (Devizes), there being no French title which distinctly described the French equivalent strata. It seems very doubtful whether any new titles are now likely to find favour. Upper and Lower Greensand are such firmly-rooted names that even if we wish it is improbable that they will cease to be used by the general body of geologists.



**LITTLE OWL IN SUSSEX.**—A good specimen of the Little Owl (*Athene noctua*) was taken at Heigh-ton, near Newhaven, on December 6th, and is now in my possession. The bird was captured in a rabbit's burrow by some travelling "peg makers" on their way from Newhaven to Lewes.—*Stanley Morris, Lewes.*

**BLACK PEPPER-AND-SALT MOTHS.**—In an article upon "Wild Animals and Civilization," in *SCIENCE-GOSSIP*, N.S., vol. i. p. 36, I referred to the appearance in Lancashire and Cheshire of a black form of *Amphidasyus tetularia*, and how it is gradually replacing the "pepper-and-salt coloured type." It is interesting to notice that our contemporary "The Entomologist," for last month, mentions the capture, this season, of two of these black forms within the London district.—*John T. Carrington.*

**PRIMITIVE TREPANNING.**—One of the most remarkable accomplishments of the ancient Peruvians was that of trepanning, an operation which is so difficult and hazardous that recovery follows only about a fourth of modern operations. In the remarkable Muniz Collection of Peruvian skulls, now temporarily in the custody of the Bureau of American Ethnology, are about one thousand specimens, of which nineteen are trepanned and eight give indications of subsequent recovery. A young female seems to have survived a series of operations, resulting in an aperture in the skull four inches long and an inch wide, which was covered by a silver plate. On the primitive methods which were adopted by the Chaouias, of the Aurès Mountains in the Province of Constantin, in Algeria, Drs. H. Malbot and R. Verneau have an interesting article in "L'Anthropologie" (vol. viii. part ii. 1897).

**DESTRUCTION OF HORNETS.**—I see in my November *SCIENCE-GOSSIP* that a Colchester correspondent has enquired how to get rid of hornets which nest in an inaccessible place. When I was a boy, living with my parents in Buckinghamshire, a colony of hornets took up their abode between roof and rafters just above the bay window of our drawing-room. They thus not only rendered that room well-nigh uninhabitable, but were found occasionally in the nursery bedroom above it. My mother, having been informed that three hornets would kill a horse—if only they were unanimous as to the part of the victim to be assailed—and excusably anxious for the safety of her babes, determined upon a counter attack. I well remember—being then at home for the holidays—the gruesome figure of a man with mask and gloves seated above the window, engaged in catching the hornets one by one in a short-handled bag-net, as they went in and out of their hole. I forget how many prisoners were captured and done to death, but in the course of two days, I think, the fortress was completely expugned, and was never again occupied by similar foes. This may be a tedious method, but it was effectual. *M. J. Tesdale, Dulwich.*

**THE SOUTH LONDON ENTOMOLOGICAL AND NATURAL HISTORY SOCIETY.**—November 25th, Mr. R. Adkin, F.E.S., President, in the chair. Mr. Tunaley exhibited xanthic specimens of *Epinephile janira* taken in North Kent in 1896, a variable series of *Angerona prunaria* from the same locality, and, on behalf of Miss Miller, of Chelmsford, an unusual variation of *Acronycta rumicis*, having a distinct submarginal red tinge on the wings, some portions of the body being similarly tinted. Mr. H. Moore, a small collection of lepidoptera taken in France last August while on a cycling tour, and contributed notes; *Epinephile janira*, generally, and *Erebia aethiops* and *E. neoridas*, locally, were the only species at all commonly seen. Chambéry was the farthest point reached. Mr. Bristowe, a small collection of lepidoptera taken during a short visit to Japan. It was remarked how close many of the species were to those of our own country, but generally much larger. Mr. Tutt, a bred series of *Ethocampa pityocampa* from larvae taken by Dr. Chapman in South France, and remarked on the considerable sexual dimorphism; also a specimen of *Eriogaster catax* from the same locality. Mr. Adkin, an asymmetrical specimen of *Arctia caja* in which the left fore and hind wings were much suffused with the dark brown colour, the right wings being normal. The specimen was one of a second brood, and emerged from pupae in October last. Mr. Harrison, F.C.S., exhibited a large number of very admirable lantern-slides illustrating the "Haunts and Habits of Birds." The lantern arrangements were kindly undertaken by Mr. Clarke, the Society's lantern and screen being used.—December 9th, Mr. R. Adkin, F.E.S., President, in the chair. Colonel Partridge exhibited specimens of *Ephyra trilinearia*. (1) Female parent, typical; (2) specimen of brood from above, dwarfed, very red, and annulated; (3) specimens of same brood, which stood over in pupal stage. The last were not so red, nor dwarfed, and the annulated spots could only just be traced. Mr. McArthur, a box of varieties captured or bred this year, including *Arctia caja*, yellow, *Abraxas grossulariata*, radiated and coalescent, and others. Mr. Montgomery, specimens of lepidoptera which had been extremely affected by grease, and which were admirably cleansed, even to the fringes of the abdomen, by the use of benzine collas and a blowpipe. Mr. Clarke, a micro-photograph of a mite which, with numerous others, he had found on a humble bee. Mr. Adkin, series of *Epinephile parallellaria (vespertaria)* from Sutherland. Mr. Step, specimens of eight species of swimming-crabs, chiefly of the genus *Portunus*, and made remarks on their habits, relationships and occurrence. He also exhibited specimens of the hermit crab which he had found in holes in rocks. Rev. Joseph Greene, of Clifton, Bristol, sent drawings of some seventy varieties of *Abraxas grossulariata* bred during the last six years near Bristol, and communicated notes thereon. Mr. Turner, eight species of the genus *Lobythea*, and read notes on their relationships, characteristics

and distribution. It was announced that Part 1 of the "Proceedings" was published, and ready for distribution.—*Hy. J. Turner, Hon. Report. Sec.*

ROYAL METEOROLOGICAL SOCIETY.—At the monthly meeting of this Society, on December 15th, at the Institution of Civil Engineers, Mr. E. Mawley, F.R.H.S., President, in the chair, Mr. W. Marriott read a paper on "The Rainfall of Seathwaite, Cumberland." This place has long been noted for its heavy rainfall, being in fact one of the wettest spots in the British Isles; the average yearly amount is 137 inches. The spring months of April, May and June are the driest, so they not only have the least rainfall, but also the least number of rainy days. August, the month when the Lake District is thronged with visitors, has the greatest number of rainy days. The heavy nature of the rainfall may be gathered from the fact that 21 per cent of the falls are above 1 inch, 2 per cent being above 3 inches. The greatest fall in one day was 8.03 inches on November 12th, 1897. The author has investigated the atmospheric conditions under which the heavy rainfalls occurred at Seathwaite, and he finds that these heavy falls are due to the direction and force of the wind. When the wind is blowing strongly from the south-east or south-west, it will be concentrated in the valleys on the windward of Scafell, and rush up them with very great force, the air current consequently being projected to a considerable altitude beyond Scafell. Owing to the reduction of temperature with elevation, the air parts with a great deal of its moisture, which falls as rain. With such a process going on continuously for a whole day, the heavy rainfall at Seathwaite is fully accounted for. Mr. R. C. Mossman, F.R.S.E., also read a paper on the daily values of non-instrumental meteorological phenomena in London, from 1763 to 1896. The phenomena discussed were, thunderstorms, lightning without thunder, fog, snow, hail and gales.

CITY OF LONDON ENTOMOLOGICAL AND NATURAL HISTORY SOCIETY.—Tuesday, November 2nd, 1897, Mr. J. W. Tutt, F.E.S., President, in the chair. Exhibits: Mr. May, series of *Leucania phragmitidis*, with var. *rufa*, from Sandown, July, 1897. Mr. Oldham, *Apamea ophiogramma* from Woodford. Mr. Garland, *Melitaea aurnia* from Carlisle larvae, and *M. cinxia* from Isle of Wight larvae, both bred this year. Mr. Prout, a series of *Lycæna icarus* bred from larvae taken from rest-harrow; a specimen of *Laphygna exigua*, taken at sugar at Sandown, September 2nd, 1897; two series of hybrid *Tephrosius* bred from June to September, 1897. These produced by the crossing of male *bistortata* with female *crepuscularia* yielded both sexes in equal proportions, and no pupæ went over. Those reared from crossing male *crepuscularia* with female *bistortata* gave only one female, which emerged on the earliest date at which the brood commenced to appear. About ten or twelve pupæ of this latter brood, but no males, went over the winter in that state. Mr. Tutt, on behalf of the Rev. W. Claxton, *Anchocelis pistacina*, var. *serena* and ab. *venosa*, *Agrotis exclamationis* ab. *picea*, *Xylophasia hepatica* ab. *characteræ*, *Miselia oxyacanthæ* ab. *capucina*. Mr. Clark, a curiously suffused variety of *Arctica caja*. Mr. Nicholson read a paper on "The Microscope," and a discussion followed.—*Lawrence J. Tremayne, Hon. Secretary.*

SCARBOROUGH FIELD-NATURALISTS' SOCIETY.—At the annual meeting an average number of members attended. The exhibits, which were not numerous, included a specimen of the great horse-

shoe bat from Tenby, South Wales; a variety of the common hare having a white breast and one hazel and one white eye. The principal item of the evening was the reports for the year just closing. Mr. R. J. Fryer read the secretaries' reports, stating that never before in the history of the society had they had such a successful year both in point of numbers and in the interest of the specimens and papers. The number of members was now about seventy, with an average attendance of twenty-two, which, when taking into consideration that the meetings were held right through the season, was very satisfactory. Excursions, though not numerous, had been very interesting, including an all-night excursion to Raincliffe Woods. The Treasurer's report showed the exchequer to be in a very satisfactory state. Mr. Gibbon also read the Library report, showing that the magazines had been more freely used by the members. Mr. C. D. Head's report for Mammals recorded the taking of two badgers in the district, and the dormouse, evidently a rarity near Scarborough. In the Reptiles none but the ordinary species had been observed. For the Amphibians the palmated newt had again been found, this time from Harwood Dale. Mr. W. J. Clarke, in his Ornithological Report, stated that species which had been verified by the society numbered 191. Steady work had been done in this branch during the year, several new records being made. For Fishes, Mr. F. Grant gave the number of sea fishes recorded as sixty species; freshwater, twenty-three species. There were four new records and one or two rarer species that had been observed. Mr. J. A. Hargreaves stated for Conchology that the remarkably successful year in 1896 had not been equalled during the year just closing, though a good deal of work had been done by the various members. The excursions held by the Children's Guild of the Parents' Educational Union had been attended and directed by the members, and similar assistance had been promised for the coming year. If like excursions could be organised for the elder children attending the elementary schools, it would be a permanent benefit to the children and indirectly to the society. One or two dredging expeditions in the South Bay had been made with varying success. When the pond in the park was emptied many fine swan mussels were obtained. New localities had been found for several species, though the districts beyond Ayton and Burniston are still unworked. Spiders being a new subject in the society, no definite report was forthcoming through the recorder; Mr. R. Gilchrist is, with difficulty, working up a useful list of species. The recorder of Coleoptera read a short paper on beetles. A globe containing glowworms, which had been captured on an excursion to Cloughton an evening earlier in the week, was also exhibited, and created great interest. The recorder for Lepidoptera, Mr. T. W. Lownsbrough, said that the year had been a failure from a collector's point of view in this branch; the beginning of the year was very mild, and in February the earlier moths were in fair abundance on the moors, larvae having been scarce. Sugaring, owing to the cold, damp nights in the summer, was a decided failure. One fresh butterfly had been recorded for the district. A paper on the subject was also read by the recorder. Mr. J. C. Harrison, for Marine work, reported the taking of a sea squirt, or ascidian, which he had still alive and under observation. Mr. E. R. Cross, following with the combined report of the Botanists, said that wild flowers and minute

pond plants had been shown frequently. No new green cryptogams had been added to the list, though there was still plenty of unexamined material on the shore and in ponds and ditches. Part of the Mere had been set apart as a botanist's corner, and it was to be hoped that some of the old species would reappear. More work had been done in fungi than hitherto, although few new records had been made, and better insight had been gained into this large and interesting Order. Altogether eighty-five species had been added to their list. Mr. J. A. Hargreaves, for Geology, said the usual amount of interest had been shown in this section, the number of members interested being greater than at any other time. Many fossils and some minerals had been shown at the meetings. The most interesting work during the year had been that carried on at the North Side in the making of the Marine Drive. So far the excavations had resulted in the discovery of very few fossils, but as the workmen approached the harbour the results would probably be more satisfactory. The recent high tides had washed away some of the clay from the great slip south of Mr. Beeforth's garden, and exposed many foreign rocks, of which the most remarkable were Carboniferous limestone, much of which is crinoidal, and a remarkable breccia, possibly identical with the one at Kirkby Stephen. Lais fossils are fairly common. Mention should be made of the rapidly disappearing hill at Scalby Mills, which had materially diminished in size during the last few years. Excursions during the year had been made to Cloughton Wyke, the Peak, and Peacock's Quarry, Falsgrave, which had been fairly well attended.

**HERTFORDSHIRE NATURAL HISTORY SOCIETY.**  
—By permission of the Earl of Essex and Sir Matthew White Ridley, the annual fungus foray took place on October 23rd last in the Swiss Cottage Woods, Cassiobury Park, and the wood-walks adjoining Cassiobury House. The foray was under the direction of Mr. Hopkinson, and the fungi were identified by Mr. George Maseke, of Kew. In the morning the party crossed the park to the grounds of the Swiss Cottage, finding about twenty species in the park and increasing the number to nearly a hundred, besides several species, not identified at the time, in the damp woods by the River Gade, opposite the Swiss Cottage, which proved to be a prolific hunting-ground, especially for microscopic forms. In the afternoon the party, increased to upwards of twenty, entered the Cassiobury wood-walks and strolled along the old high road which passes through them. The search for fungi was here made in rather straitened circumstances, as the members were restrained by a zealous keeper from deviating out of this road, beyond its banks at least, for fear a pheasant might be disturbed. Notwithstanding this restriction, the number of species found in the morning was nearly equalled in the afternoon, thus almost doubling the record, and there was again a much larger proportion of microscopic fungi than has been found at previous forays. The great find of the day was that of *Agaricus (Clitocybe) saddlei*, discovered by Miss Buchanan. The species was first found growing on a tub in the Botanic Gardens in Glasgow, and there is no previous record of its occurrence in England. It has now been added to the English list of fungi by a young lady whose native place is, by a coincidence, the same as that whence came the fungus, or at least our knowledge of its existence as a species.

## NOTICES OF SOCIETIES.

## GEOLOGIST'S ASSOCIATION OF LONDON.

Jan. 7.—"Excursions in the Urals, Caucasus, etc." L. L. Belimfante, M.Sc.

## LUBBOCK FIELD CLUB.

Jan. 9.—Excursion to Carshalton and Farden Downs Leave London Bridge 9.55 a.m.  
" 10.—Exhibition Meeting.

## NORTH LONDON NATURAL HISTORY SOCIETY.

Jan. 1 & 3.—Sixth Annual Exhibition, North-East London Institute, Dalston Lane.

" 6.—Presidential Address.  
" 20.—Short Papers on 1897.  
Feb. 3.—"Rainfall in India." Stephen Horsley, M.I.C.E.  
" 12.—Visit to the Horniman Museum, Forest Hill, conducted by K. Quick.  
" 17.—"London Clay." J. E. Greenhill, F.G.S.  
Mar. 17.—"Insectivorous Plants." R. W. Robbins.  
" 19.—Visit to the Bethnal Green Museum.  
April 16.—Visit to Kew Gardens.  
" 21.—"Lepidopterous Larvae." A. Bacot.  
May 5.—Discussion: "Nebulæ." Opened by C. Nicholson, F.E.S.  
" 21.—Half-day Excursion to Epping Forest.  
" 27-30.—Excursion to the New Forest—leader, L. J. Tremayne.  
" 30.—Alternative whole-day Excursion to Shere.  
June 16.—"The Catocalidae." E. M. Dadd  
" 18.—Whole-day Excursion to Deal—leader, L. J. Tremayne.

Visitors will be cordially welcomed at all meetings and excursions. *Lawrence J. Tremayne, Hon. Sec.*

## SOUTH LONDON NATURAL HISTORY SOCIETY.

Jan. 27.—Annual Meeting.

## SELBOURNE SOCIETY—CROYDON AND NORWOOD BRANCH.

Jan. 25.—"Sheep and Goats." E. A. Martin, F.G.S. Lantern slides. Seneca Hall, Thornton Heath. 8 p.m.  
Feb. 5.—"Health and Fashion." E. J. Davies, Lantern Slides. Thornton Heath Polytechnic. 8 p.m.  
April 7.—Social Evening. Exhibits, etc., will be welcomed. Rev. F. E. J. Bird, *Vice-President*, will speak. Seneca Hall, 8 p.m.  
" 21.—Annual Meeting, at Public Hall, Croydon. Subject: "The New Forest." Rev. H. E. H. Bull, M.A. Lantern slides. 8 p.m.

## NORTH KENT NATURAL HISTORY AND SCIENTIFIC SOCIETY.

Jan. 12.—"Bacteria." C. J. Brooks.  
" 26.—"Entomology." H. Broughton.  
Feb. 9.—"Leaves: their Structure and Use." J. W. Cooper.  
" 23.—"Aquaria and Uncommon Pets." Jno. Potter.  
Mar. 9.—"Conchology." E. Dennis.  
" 23.—"British Birds, Eggs and Nests." D. Miller.  
April 6.—"Lepidoptera." S. J. B. Pine.

## CARLISLE ENTOMOLOGICAL AND NATURAL HISTORY SOCIETY.

Jan. 3.—"Review of 1897."  
" 17.—Annual Exhibition of Specimens.  
Feb. 7.—"Coleoptera." F. H. Day.  
" 21.—"Prehistoric Man." J. Murray.  
Mar. 7.—"Lepidoptera taken at light in Carlisle." J. E. Thwaytes.  
" 21.—"Observations on Bird life." B. Johnston. *F. H. Day, Hon. Sec., 6, Currock Terrace, Carlisle.*

## HULL SCIENTIFIC AND FIELD NATURALISTS' CLUB.

Jan. 5.—"The Fishes of the River Hull." H. M. Foster.  
" 19.—"The formation of an English Village," lantern illustrations. J. R. Boyle, F.S.A.  
Feb. 2.—"Breeding-Haunts of British Birds," lantern views. T. Audas, L.D.S.  
" 16.—"An Early Doctrine of Evolution." Rev. C. A. Hall.  
Mar. 2.—"The Natural History of Goole Moor." Thos. Bunker.  
" 16.—"Spectroscopic Astronomy," lantern illustrations. Rev. H. P. Slade, M.B.A.A.  
" 30.—"The Marine Fauna of the Yorkshire Coast," lantern views. F. W. Flerke, M.C.S.  
The Meetings held at 72, Prospect Street, alternate Wednesdays, 8 p.m.—*T. Sheppard, Hon. Sec., 78, Sherburn Street, Hull.*

## PRESTON SCIENTIFIC SOCIETY.

Jan. 19.—"Beer." Rev. J. Browne, S.J.  
April 6.—"Methods of Fishing and Fish Culture on our coasts." R. L. Acroft (Member of the Lancashire Sea Fisheries Committee).  
" 20.—"Biography of a Fern." W. Clitheroe. Illustrated by oxy hydrogen lantern.  
Lecture Hall, Cross Street, Whinckley Square, 8 p.m.  
*W. H. Heathcote, F.L.S., Secretary, 17, Frenchwood Street.*

- TUNBRIDGE WELLS NATURAL HISTORY SOCIETY.  
 Jan. 14.—"Lepidoptera." H. Shepherd Walwyn.  
 " 28.—"How men did business 4,000 years ago."—H. S. Robertson, B.A., B.Sc.  
 Feb. 11.—Specimen and Microscopical Meeting. Short Paper, "An Oak Tree Problem." R. Russell Hutchinson.  
 " 25.—"Kakatoa, the great Volcano." Sir Robert Ball, F.R.S., LL.D.  
 " 26.—"A Universe in motion." Sir Robert Ball, at 3 p.m.  
 Mar. 11.—"Torpedo Warfare." Fleet Engineer T. J. Haddy, R.N.  
 " 25.—"Honeycombing and other forms of weathering of stone." Illustrated by lantern. Geo. Abbott, M.R.C.S.  
 April 8.—"Problems in Plant Life." Benj. Lomax, F.L.S.  
 May 6.—Annual Meeting.  
 Ordinary Meetings in the Literary Society's Library, 32, Pantiles, on Friday evenings at 8.—Miss Cooke, Hon. Sec., 19, Guildford Road.
- WARRINGTON FIELD CLUB.  
 Jan. 21.—"The Geological Action of Volcanoes, with special reference to North Wales." W. H. Woodcock.  
 Feb. 4.—Short Papers: "Algæ," Rev. H. Brierley. "Physiology of Respiration," lecture, Dr. Bowden.  
 " 18.—"Plant Structure: the Stem and the Flower." A. T. Gillanders.  
 March 4.—"Frog Spawn." L. Greening, F.L.S., M.R.I.A.  
 " 18.—Entomological Evening and Annual Meeting. 7.30 p.m., in the Museum Lecture Room.  
*Alf. J. Jolley, Hon. Sec.*

#### METROPOLITAN SCIENTIFIC SOCIETIES.

- The following is a list of societies in the London district devoted to natural science, with hours and places of meeting. They may be visited with introduction from a Fellow, Member, or Secretary. Will secretaries send additions or corrections.
- ANTHROPOLOGICAL INSTITUTE OF GREAT BRITAIN, 3, Hanover Square. Second and fourth Tuesdays at 8.30 p.m., November to June.
- CITY OF LONDON COLLEGE SCIENCE SOCIETY, White Street, Moorfields, E.C. Last Wednesday in each month, October to May, 7.30 p.m.
- CITY OF LONDON ENTOMOLOGICAL AND NATURAL HISTORY SOCIETY, London Institution, Finsbury Circus. First and third Tuesdays, 7.30 p.m.
- CONCHOLOGICAL SOCIETY, LONDON BRANCH, St. Peter's Rectory, Walworth. Irregular meetings. Rev. J. W. Horsley, President, will answer enquiries.
- CROYDON MICROSCOPICAL AND NATURAL HISTORY CLUB, Public Hall. Third Tuesdays, October to May, 8 p.m.
- DULWICH SCIENTIFIC AND LITERARY ASSOCIATION. Fortnightly lectures Lordship Lane Hall, second and fourth Mondays, 8.15 p.m., from October, for winter season.
- EALING NATURAL SCIENCE AND MICROSCOPICAL SOCIETY, Victoria Hall, Ealing. Second and last Saturdays, October to May, 8 p.m.
- ENTOMOLOGICAL SOCIETY, II, Chandos Street, Cavendish Square. First Wednesday, October to June (except January). Third Wednesday, January, February, March and November, 8 p.m.
- GEOLOGISTS' ASSOCIATION, University College, Gower Street. First Friday, 8 p.m., November to July.
- GEOLOGICAL SOCIETY OF LONDON, Burlington House, Piccadilly. First and third Wednesdays, 8 p.m., November to June.
- LAMBETH FIELD CLUB AND SCIENTIFIC SOCIETY, St. Mary Newington Schools, Newington Butts, S.E. First Mondays all the year and third Mondays in winter, 8 p.m.
- LINNEAN SOCIETY OF LONDON, Burlington House, Piccadilly. First and third Thursdays at 8 p.m., November to June.
- LONDON AMATEUR SCIENTIFIC SOCIETY, Memorial Hall, Farringdon Street, E.C. Fourth Friday in each month, October to May, 7.30 p.m.
- LUBBOCK FIELD CLUB. Working Men's College, Great Ormond Street, Bloomsbury, W.C. Excursions second Sundays, Meetings following Mondays, 8 pm.
- MALACOLOGICAL SOCIETY OF LONDON, meets in Linnean Society's Rooms, Burlington House. Second Friday each month, November to June, 8 p.m.
- MINERALOGICAL SOCIETY. Meets in rooms of Geological Society, February 4th, April 14th, June 23rd, November 17th, 8 p.m.
- NONFARIEL ENTOMOLOGICAL AND NATURAL HISTORY SOCIETY, 99, Mansfield Street, Kingsland Road, N.E. First and third Thursdays, 8 p.m.
- NORTH KENT NATURAL HISTORY AND SCIENTIFIC SOCIETY, St. John's Schools, Wellington Street, Woolwich. Alternate Wednesdays, 7.30 p.m.
- NORTH LONDON NATURAL HISTORY SOCIETY, North-East London Institution, Hackney Downs Station. First and third Thursdays, 7.45 p.m.

- QUEKETT MICROSCOPICAL CLUB, 20, Hanover Square. First and third Fridays, 8 p.m.
- ROYAL BOTANIC SOCIETY OF LONDON, Regent's Park. Second and fourth Saturdays at 3.45 p.m.
- ROYAL HORTICULTURAL SOCIETY, 117, Victoria Street, S.W. Second and fourth Tuesdays, except December to February; 2 p.m. on show days, which vary.
- ROYAL METEOROLOGICAL SOCIETY, 22, Great George Street, Westminster. 3rd Wednesday, November to June, 8 p.m.
- ROYAL MICROSCOPICAL SOCIETY, 20, Hanover Square. Third Wednesdays, October to June, 8 p.m.
- SELBORNE SOCIETY, 20, Hanover Square. No winter meetings.
- SIDCUP LITERARY AND SCIENTIFIC SOCIETY, Public Hall, Sidcup. First and third Tuesdays, October to May, 8 p.m.
- SOUTH LONDON ENTOMOLOGICAL AND NATURAL HISTORY SOCIETY, Hibernia Chambers, London Bridge, S.E. Second and fourth Thursdays, 8 p.m.
- SUTTON SCIENTIFIC AND LITERARY SOCIETY, Public Hall Chambers. Second and fourth Tuesdays, 8 p.m.
- WEST KENT NATURAL HISTORY, MICROSCOPICAL AND PHOTOGRAPHIC SOCIETY. Meets in School for Sons of Missionaries, Blackheath, third Wednesday, in December, fourth Wednesdays in October, November, January, February, March, April, May, 8 p.m.
- ZOOLOGICAL SOCIETY OF LONDON, 3, Hanover Square. First and third Tuesdays, 8.30 p.m., November to August.

#### NOTICES TO CORRESPONDENTS.

TO CORRESPONDENTS AND EXCHANGERS.—SCIENCE-GOSSIP is published on the 25th of each month. All notes or other communications should reach us not later than the 18th of the month for insertion in the following number. No communications can be inserted or noticed without full name and address of writer. Notices of changes of address admitted free.

BUSINESS COMMUNICATIONS.—All Business Communications relating to SCIENCE-GOSSIP must be addressed to the NASSAU STEAM PRESS, LIMITED, 86, St. Martin's Lane, Charing Cross, W.C.

SUBSCRIPTIONS.—Subscriptions to SCIENCE-GOSSIP, at the rate of 6s. 6d. for twelve months (including postage), should be remitted to the NASSAU STEAM PRESS, LIMITED, 86, St. Martin's Lane, Charing Cross, W.C.

Strictly Editorial communications, *i.e.*, such as relate to articles, books for review, instruments for notice, specimens for identification, etc., to be addressed to JOHN T. CARRINGTON, 1, Northumberland Avenue, London, W.C.

THE Editor is not responsible for unused MSS., neither can he undertake to return them, unless accompanied with stamps for return postage.

#### EXCHANGES.

NOTICE.—Exchanges extending to thirty words (including name and address) admitted free, but additional words must be prepaid at the rate of threepence for every seven words or less.

WANTED, foreign shells, Crustaceans and Echinoderms; exchange good canaries, fossils, micro. slides, photo-micrographs and books.—H. W. Parritt, 8, Whitehall Park, N.

OFFERED, British marine and land shells; also SCIENCE-GOSSIP, odd Nos. for 1881, 1888, 1890, 1891, 1892, 1893, 1894. What offers?—A. H. Shepherd, 81, Corinne Road, Tuffnell Park, London.

WANTED, rock-sections, micro. lamp and geological literature. Offered, O'Meara's "Report on the Irish Diatomaceæ" plates; "Transactions of the Quekett Club"; vol. i. of "The Scientific Enquirer"; "Transactions of the Linnean Society (Botany)"; and a great number of brochures on geological subjects, also some hundreds of mounted and named specimens of foraminifera.—J. H. Cooke, Thorndale, Lincoln.

Will exchange diatom slides for other objects, or books on microscopy.—H. Platt, Priory Villa, Victoria Road N., Southsea.

FOR EXCHANGE.—A large number of British and foreign and, freshwater and marine shells. Foreign correspondents desired, especially West Indies and South America.—A. Hartley, 14, Croft Street, Idle, Yorkshire.

"STUDIES IN MICROSCOPICAL SCIENCE," by A. C. Cole, F.R.M.S., vol. i. complete, unbound, with 52 slides in cabinet, all in good condition. What offers?—Thos. Bolton, 25, Balsall Heath Road, Birmingham.

WANTED, offers for the whole of SCIENCE-GOSSIP, 1865 to 1897; first 28 volumes in publisher's cover, remainder unbound.—G. P. Bonny, 30, Wellington Road, Stoke Newington, London, N.

WANTED, bacteriological slides and  $\frac{1}{16}$  or  $\frac{1}{32}$  micro. objective. Exchanges: whole insects and parts, mostly prof. mounts, for oxy-hy. micro., also geological slides; Oertling's full-sized chemical balance, in perfect working order, with set grain weights.—H. W. Case, F.R.M.S., Cotham, Bristol.

## WILD TRAITS IN TAME ANIMALS.

AMONG the people one meets from time to time, one hears the complaint, how impossible it is to conduct any series of investigations into Nature without special natural science training

the perusal of Dr. Louis Robinson's recent work (1), upon his studies of the wild characters and habits which have been perpetuated in domestic animals. We are apt to forget that in looking for subjects

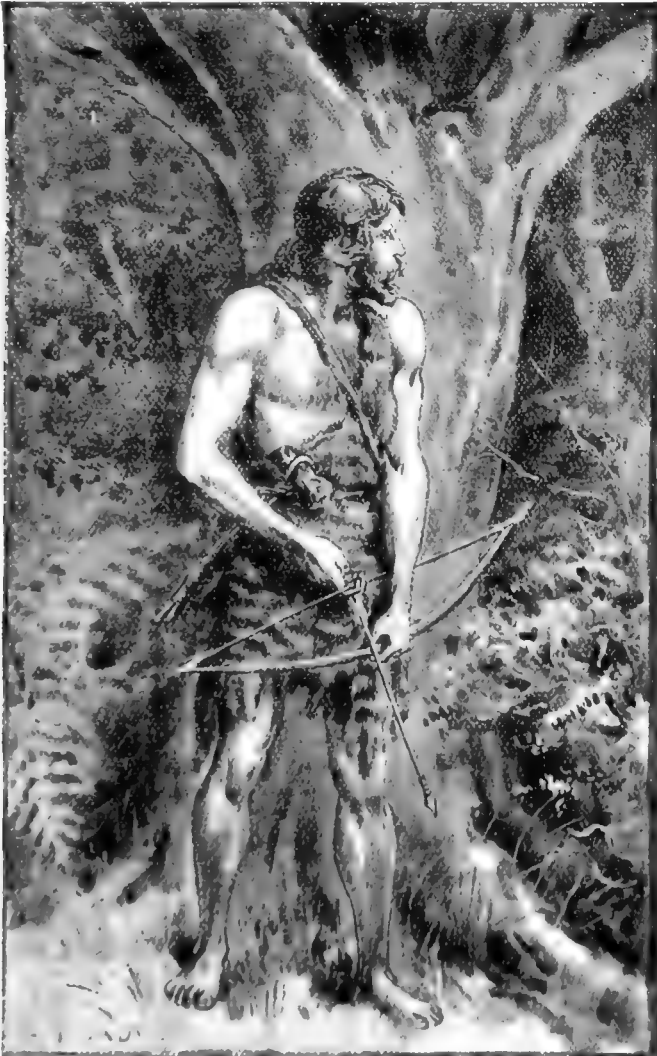

A PRIMITIVE NATURALIST

and elaborate apparatus. For this reason intelligent people who are really anxious and willing to do something which will contribute to our general knowledge go through life without commencing such investigations. To these we would recommend

for scientific research, some which yield the most prolific results for our labours are most familiar

(1) "Wild Traits in Tame Animals." By Louis Robinson, M.D. 336 pp. 8vo. Illustrated by six plates and ten drawings in text. (Edinburgh and London: William Blackwood and Sons, 1897.) 10s. 6d. net.



and apparently commonplace. It is by no means necessary that we should possess delicate apparatus, a University training, or indeed much else than acute observation, with the faculty of sifting and arranging the facts as they appear to us.

As a good instance of what we mean, Dr. Robinson has shown how much satisfaction may be obtained from watching the habits of such familiar creatures as the sleeping cat on the hearth, or the bright and intelligent four-footed companion of our daily walks. From long ages, remote in the dim recesses of the earliest civilization of man, either he has himself chosen to be associated with one or other wild animal, in an apparently unnatural companionship, or it is possible in the earliest times some individuals of these found advantage in placing themselves under his protection. We must remember also, that with the rise of man's intelligence from a condition probably lower than that of some of the higher feral animals now existing, those which have been closely associated with mankind have to some extent shared in his civilization. It is true that in consequence of the extensive range of man's expression by articulate sounds he has distanced all other animals in intelligence. The reason for this is because he has had the advantage of accumulating the experience of his ancestors. If we had had to depend entirely upon the relation of such experiences by these articulate sounds, it is doubtful whether any race of mankind would have been much in advance of a semi-savage condition. Our progress to a higher intelligence depended far more upon the first accident which led to the discovery that a series of marks would aid the memory of those who desired to pass down to posterity the knowledge which had been found useful in protecting our kind in the fight for life. If we consider what is known of the position of man five or six thousand years ago, and that of the most civilized races five hundred years back, and compare these again with our own times, we cannot fail to remark how recent is our present artificial condition.

What strikes one as remarkable is, that with all his intelligence and close association with other animals during an innumerable series of generations, man should never have found a direct means of exchanging his thoughts with any other species. This being so, we have to content ourselves by studying their habits, and comparing those of our "civilized" domestic animals with their nearest allies in a wild condition. Before doing so, it is quite worth while to study ourselves, or our human neighbours, to see what remains to indicate the style of life led by our wild ancestors.

In the introduction to his work under notice, Dr. Robinson fully realizes this fact, and attempts to trace some of our commonest habits directly to others which were necessary to savage man when

he depended for his daily food upon his acuteness of observation. With a fluency and freshness of style which characterizes this book, Dr. Robinson compares the observation necessary to make a successful student of the theory of evolution, with that of his savage ancestor, whose everyday business was first self-protection from his enemies, and then to provide food for himself and his offspring. The author writes imaginatively:

"The sun has risen over the great eastern plain that now constitutes the German Ocean. From his dwelling-place, consisting of a river-side cave, the entrance of which is closed by roughly interlaced branches, strides our primitive forefather. He is a brawny, hirsute savage, hard-featured and ruddy, like a modern tramp, with his face and naked limbs stippled over with tattoo marks. His dress, such as it is, is made of skins of the deer and wild cat, and is drawn together by a belt holding a flint axe. In his hand is a bow, and hanging behind his left shoulder a rough quiver of flint-tipped arrows. After a keen look at the sky and up and down the valley he moves steadily away among the bracken and brambles towards a spot where the spotted deer of the forest are wont to drink at the stream. As he steps silently along, his eyes and ears are alert for the least indication of the presence of prey or of dangerous neighbours. A hundred facts have already been observed and commented upon (although perhaps unconsciously) before he arrives at the river-bank. He has, in fact, during this short "journey to business," been reading his morning paper, including the Weather Forecast. The news of the night and the state of the markets as they affect his own special calling. As in the case of most of us when we read our morning newspapers, many of the items displayed before his eyes do not awake any interest. For instance, the varnished petals of the buttercup which reflect the golden sunlight are there to catch the attention of the wild bees which are already fussing around them. Such advertisements do not concern him at all, and he does not trouble himself about them any more than we trouble ourselves about wants of people with whom we have no points of contact.

As he nears the trampled spot where the thirsty herds approach the water, he hears the shrill cackle of a blackbird away in the forest some two hundred paces beyond the deer path, and the screech of a jay, accompanied by the warning "pink pink" of a pair of chaffinches, coming from a spot near to him. Instantly he slips behind the bole of a tree, and stands motionless and alert, with an arrow upon the string, for he has received sure intelligence that some beast of prey is prowling near, and it is necessary he should gain the fullest information before proceeding. As he stands there still as the tree trunks about him, do you imagine that his mind (although the nearest alphabet is ten thousand years off in the future) is sluggish or inactive? It would be well for us if we could bring such keen and apposite thoughts to bear upon our avocations whenever we wished as those which are now coursing through his brain. A dozen different theories suggested by the signs, are being sifted with lightning rapidity, and masterly discretion by the machinery inside of that weather-beaten head. At the same moment every faculty is keenly stretched for further information which may aid in the conclusion he must



come to before he stirs hand or foot. Is it merely a belated fox slinking home to his earth in the oak grove; or is some larger and more terrible beast—some huge brindled *Machirodus*, or cave-bear, prowling among the woods in front of him? Within a few minutes, while he stands there scarcely moving an eyelid, he has received reports enough from the disturbed birds and beasts in the valley to fill a column in the "Times"; by comparing the different notes of alarm which teach his ears he learns at length that there are two sources of provocation afoot.

These conclusions have been come to not only through the gathering of innumerable facts, but by means of elaborate logical processes and a power of judging the comparative value of evidence which would do credit to a modern Lord Chancellor.

"Whether or not this imaginary portrait is correct in its details, I think we may be tolerably positive as regards one particular. It was an inevitable and essential mental habit with him not only to gather facts but to read their meaning, both immediate and remote. Now, if we are justified in ascribing the delight which the study of natural history gives to the fact that when we are engaged in such pursuits we are obeying an inherent impulse derived from our innumerable hunting ancestors, it follows that the more closely such primitive instincts are obeyed the more enjoyment will the naturalist be likely to get from his pursuits."

By permission of Messrs. William Blackwood and Sons, we have pleasure in reproducing Mr. S. T. Dadd's suggestive drawing of the author's "Primitive Ancestor," and cannot help remarking that Dr. Robinson ought to be proud of him.

In dealing with the wild characters of domestic animals, Dr. Robinson is at times not only suggestive but happy in describing them, as will be gathered from quotations from the chapters on dogs and cats.

"There are many reasons for the tail being the chief organ of expression among dogs. They have but little facial expression beyond the lifting of the lip to show the teeth and the dilation of the pupil of the eye when angry. Among the wild *Canidae*, all of whom have stiff, erect ears, emotion is shown in the head or visage even less than among domestic dogs. The jaws and contiguous parts are too much specialised for the serious business of seizing prey to be fitted for such purposes as they are in man. With dogs which hunt by scent, the head is necessarily carried low, and is therefore not plainly visible except to those close by. But in the case of all hunting dogs, such as foxhounds, or wolves which pack together, the tail is carried aloft and is very free in movement. It is also frequently rendered more conspicuous by the tip being white, and this is invariably the case when the hounds are of mixed colour. When ranging the long grass of the prairie or jungle the raised tips of the tails would often be all that an individual member would see of his fellows. There is no doubt that hounds habitually watch the tails of those in front of them when drawing a cover. If a faint drag is detected suggestive of the presence of a fox, but scarcely sufficient to be sworn to vocally, the tail of the finder is at once set in motion, and the warmer the scent the quicker does it wag. Others seeing the signal

instantly join the first, and there is an assemblage of waving tails before ever the least whimper is heard. Should the drag prove a doubtful one the hounds separate again and the waving ceases; but if it grows stronger when followed up the wagging becomes more and more emphatic until one after another the hounds begin to whine and give tongue and stream off in Indian file along the line of scent. When the pack is at full cry upon a strong scent the 'sterns' cease to wave, but are carried aloft in full view.

"Although cats live in closer association with mankind than do any other domestic animals, they have been less influenced by us, both as regards their bodies and their mental habits, than any of the creatures which we have been discussing. All the rest have become man's slaves or servants, although in some cases they may be said to attain to a more equal and honourable relationship. But the cat can scarcely be classed as a servant, since it seldom yields to restraint or acts under orders; and, moreover, its co-operative relations with mankind are of a very loose and limited character. Even if we regard the cat as a partner we must acknowledge that it takes a very free-and-easy view of the bond. It comes and goes when it chooses, transacts its share of the business of the firm (in the rat and mouse department) strictly in its own way, selects its mates with an utter disregard of the views of its human colleagues, and habitually keeps outrageous hours. We, many of us, put up with a great deal from our servants and co-workers; but what employer or member of a firm would tolerate from his associates in business brawls and riotous orgies on his roof at two o'clock in the morning?

"We may expect, therefore, to find remaining in the cat a great many attributes which were developed, not to meet any present needs, but to enable it to encounter the emergencies of a wild life in the forest before it joined its fortunes with those of men."

It is neither possible, nor would it be fair to the author and publishers, to continue quoting the many striking observations which occur in the pages of Dr. Robinson's work. Some of his instances will possibly be considered "far fetched" by too critical readers. They are, however, exceedingly interesting, and may be of value in educating some persons in lines of thought that may bear future fruit. The chief fault in our author's work is an amiable one, and readily forgiven; it is a tendency, in some instances, to make conclusions fit observations. This may be corrected by the reader himself using such judgment and experience as he may possess.

As a whole this book may be considered an excellent contribution to popularising the Darwinian theory of evolution, and Dr. Robinson is to be congratulated on issuing, in such pleasant style, a series of observations of everyday events, which will interest all his readers. He has gathered many interesting facts relative to domestic animals which are frequently overlooked. These the author has woven into a pleasant story, and one which will be sure to lead to a closer observation of our pets and farmyard friends.—*J. T. Carrington.*

## THE EVOLUTION OF THE ANIMAL CELL.

BY JOSEPH SMITH, M.R.I.A., F.L.S.

THE eminent biologist, Hertwig, when considering the morphological properties of the cell, precludes his considerations by stating that "the cell is an organism by no means a simple one, being built up of different parts or constituents which for the greater part elude our observation at present; and to ascertain with accuracy the true nature of which will remain a problem for biological research for a long time to come." Such is the summary on cell structure to the present time, and it leaves us somewhat in the same happy position as were the observers of biological phenomena of the last century, yet the advances which have within the last few years been made in biological investigation, and the consequent results placed before the thinking community, should increase our appreciation of the interest which surrounds the phenomenon of life.

The parts which constitute the body of the animal and those which form the tissue of the plant, although differing in shape and method of growth, are now recognized as being both built up by the aggregation of a number, generally of a considerable number, of elements which have been variously termed constituting or histic elements, anatomical elements, and cells. Plants and animals, therefore, are constituted respectively of similar elements possessing the same fundamental structure, a feature which induces biologists to regard such construction, the result of this aggregation of elementary units, as cell structure. Each of these elements in reality represents a living particle, and cannot, therefore, be considered otherwise than as a living being. They possess and enjoy all the essential properties of such a being. Therefore, the animal and plant should be regarded from an anatomical point, as a federation of those elements, varying more or less in their form and attributes, their activity being considered physiologically as the consummation of their individual existences, co-ordinated towards a common end. This idea of the living being, the only one which finds itself in harmonious relation with the legitimate requirements of modern science, therefore implies a knowledge of those primary parts which in the aggregate form the animal body and vegetable tissue. The study of these elementary units falls within the sphere of all those who desire to acquire any knowledge of the vital phenomena which surround us, whether such investigations be undertaken in connection with health or disease; consequently the subject is one the botanist, zoologist and physiologist must participate in to enable each to acquire any

correct knowledge of the special branch of study in which he finds himself engaged. It is in the cells<sup>(1)</sup>, to which the anatomist reduces both plant and animal organisms, that the vital functions are executed, they, the cells, being, according to Virchow, the vital elementary units. The cell, moreover, is the axis on which the science of Histology, which is the examination of the minute construction of the animal body, rotates; it is the basis of the comprehensive study of minute anatomy in both the animal and vegetable kingdoms.

The original idea conceived by the word cell, as used scientifically, has much altered during the second half of the present century, and this is chiefly attributable to the investigation which has been made. It is not in any wise improbable that our knowledge on this point may be considerably increased by the better and more delicate methods of investigation arising from the improved optical instruments now available. These may eventually enrich us with an entirely new series of conceptions, so that the idea as at present conveyed by the term cannot be regarded as final or perfect.

Before Schleiden the investigation of cells was suggested to Malpighi<sup>(2)</sup> and Grew<sup>(3)</sup> by the study of plant structure. Caspar Fredk. Wolff<sup>(4)</sup> and Oken<sup>(5)</sup> also investigated the development of plants, and endeavoured to demonstrate that their original structure was due to the aggregation of cells; but Treviranus<sup>(6)</sup> showed that vessels developed from cells, that a systematic arrangement in rows existed, that a transformation of cells took place, and finally resulted in a rupture of the partition walls. Mohl some years afterwards established this as a scientific fact. Schleiden was the first to demonstrate the cell theory in connection with plants<sup>(7)</sup>, when he endeavoured to explain the mystery of all formation. The discovery which Brown made during his investigation on orchids<sup>(8)</sup>, that nuclei existed in some of the cells, was the key

(1) "The Cell Outlines of General Anatomy and Physiology," by Oscar Hertwig, translated by Campbell. (London, 1895.) p. 1.

(2) "Anatome Plantarium."

(3) "The Anatomy of Plants."

(4) "Theorie von Generation" (1764).

(5) "Lehrbuch der Naturphilosophie."

(6) C. L. Treviranus vom inwendigen Bau der Gewäcche, 1806.

(7) Matthias Schleiden: "Beitrage zur Phytogenesis." Müller's Archiv, 1830. "Principles of Scientific Botany," translated by Lancaster, 1849.

(8) R. Brown: "Observations on the Organs and Modes of Fecundation in Orchideae and Asclepiadeae." "Transactions of Linnean Society." London, 1833.

to further discoveries of a similar nature by Schleiden. He showed that these nuclei were found in the cells of many species of plants; but that only occurring, so far as he could observe, in the young cells, he argued they had therefore some near connection with the mysterious commencement of the cell, and consequently must form a prominent feature in vital development. To a certain point Schleiden was correct, for the nuclei do act as important factors in progressive growth, but they do not affect the beginning of cell formation. However, by means of these observations on plant structure the cell theory was first applied to animal substances, and a great interest was centred in the application of this theory, since it is in the animal cell that the nuclei stand out most prominently. We cannot, however, ignore the work which had been done about this period by others who endeavoured to show that the animal tissue was built up of numerous minute elements; but these theories could not be developed further because of the incorrect observations on which they were based, so that any beneficial results which might have been obtained would only have been outweighed by errors. Purkinje<sup>(9)</sup>, Müller<sup>(10)</sup>, and Henle<sup>(11)</sup>—all three had worked out theories on the cell formation of animals and plants—endeavoured to show the correlation existing between the different portions of the animal tissue and that of the vegetable. It was not, however, until the idea suggested itself to Schwann, in a conversation he had with Schleiden on the merits of the cell theory, that the resemblance between the cells of the plant and animal tissue might be of importance in the development of the vital phenomena, that anything feasible was arrived at. He at once set on foot a series of experiments, and the results of these experiments he published in his book<sup>(12)</sup>, which may be considered as the most valuable work of the period. It was the means of extending the knowledge of the microscopical structure of the anatomy of animals, and notwithstanding the difficulties in observation which had to be submitted to, the result of Schwann's researches was to elevate animal anatomy to the same level as that of plants.

The cell is the true basis of knowledge, both morphologically and physiologically, in zoology and botany, and it must therefore be regarded as an integral organism possessed of independent life. Schwann made most important use of the nucleus in demonstrating the animal cell, emphasising the

statement that it is the most characteristic and least variable of the cell constituents. Whether we examine a flower, section of a stalk, or fruit, or extend our observation to the structures of bone, skin, or flesh, the same truism manifests itself, and we find these structures built up of cells aggregated together. Various views have been entertained as to the constitution of the cell or unit and its real nature, but whatever view may eventually be adopted as regards its nature and structure, it must be acknowledged to be a unit of independent function and existence. Brücke<sup>(13)</sup> emphasises it as an elementary organ, and the anatomist, Virchow<sup>(14)</sup> styles it the seat of life, but Hækel<sup>(15)</sup> defines it as the "organic unit of form of the lowest grade," and assumes this definition to be the most accurate description of this wonderful organism. It is functional, both anatomically and physiologically, and is found constituting one-celled plants—the Protista—and animals. The term, however, is not perhaps so well chosen as to be free from some objection to its general application; but Schlieden adopted it as the most comprehensive term to describe those small organisms which in most plants, when made in cross section, had in appearance great affinity to the chambers of the honeycomb, being all massed together, but separated by a wall or partition, and filled with some kind of liquid or soft pulpy matter. When this theory was applied to the animal world, the same terms were adapted by Schwann as sufficiently descriptive of a small sac closed, or bladder filled with fluid, and surrounded by a solid wall or outer covering. This was the general term applied to describe those single structures which are such important and prominent factors in the progression of all animal and vegetable life. Yet, however, some anatomists do not consider the description to be an adequate conception of the phenomenon of cell life, and regard the choice of the term as misplaced, for it is argued that those parts of the animal body which had hitherto been denominated cells were on investigation shown to be different, while the further investigation was carried the plainer it became that the nature of the cell must be "entirely differently conceived."

To meet this view the cell is now defined<sup>(16)</sup> as "a small solid, or semifluid—that is, neither solid nor fluid—dense body, the chemical nature of which is albuminous, and in which another roundish body, generally more solid, and always albuminous, is enclosed. An envelope or membrane may exist,

<sup>(9)</sup> Purkinje: "Uebersicht der Arbeiten und Veränderungen der Schlesiischen Gesellschaft für Vaterländische Cultur in Jahre 1839." Breslau, 1840.

<sup>(10)</sup> J. Müller: "Vergleichende Anatomie der Myxinsiden." 1837.

<sup>(11)</sup> Henle: "Symbolae ad anatomiam villorum Intestinalium." 1837.

<sup>(12)</sup> Schwann: "Mikroskopische untersuchungen über die Uebereinstimmung in der Structur und dem Wachsthum der Thiere und Pflanzen."

<sup>(13)</sup> Brücke: "Die Elementarorganismen wiener stützungsaber." Jahrg., 1861, xlv. 2, Abth.

<sup>(14)</sup> R. Virchow: "Cellular Pathology as based on Physiological and Pathological Histology." Translated by Chancé, 1858.

<sup>(15)</sup> "Evolution of Man," p. 123, vol. I. London, 1883.

<sup>(16)</sup> Hækel: "Evolution of Man," vol. I, p. 125. London, 1881.

as is the case in most plant cells; but it may be absent, which is the case with most animal cells. Originally it is never present."

The composition of the cell consists of two parts: the inner part which is termed the nucleus, the centre of vitality—on this the cell depends for segmentation and aggregation—and the outer or surrounding elementary matter, the cell slime or protoplasma, a compound of carbon and nitrogen, which is of efficiency on that period arriving when the potentiality of the nucleus begins to assert itself, for the segmentation and consequent aggregation of the cellular life, which ultimately reasserts itself in the adult individual. The shape of the nucleus is varied: it is sometimes round and sometimes it is oval, even at times assuming the form of a spheroid. In consistency it is similar to the surrounding elementary protoplasma, generally slightly more solid, never softer than the cell slime, which remains throughout its existence in the same state of density. The core and the protoplasma are the two essentials of all existence. All other particles of matter are subservient to these two great elements or constituting factors of the cell. They must be regarded as passive, that is to say, in a state of quiescence, having been assumed from without in the active bearing of the protoplasm, or formed by the interchange of movement through which this great and beautifully constituted attribute of life is continually passing. Life, or vitality, therefore depends on the growth and development of this original animal cell or ovum.

Now this term "life," or vitality, which forms one of the attributes, undoubtedly the greatest and grandest attribute of the development of cell structure, is a feature to define which correctly and intelligibly, a variety of attempts has been made by the many who have striven towards a solution of the mystery. So far, however, the definitions or explanations which have been given of life have not been sufficiently concise and explicit, to settle that ever-interesting question as to what is to be understood by "life." Hence the term has been utilized to explain the existence of man and animals equally with that of a mucus, or pus, or white blood corpuscle. Yet the life of man cannot be considered similar, inasmuch as many hundreds of such white blood corpuscles, or elementary units of the tissues, might die in the man without affecting the life of man, while on the other hand the man might die and still some of the corpuscles remain<sup>(17)</sup>. We must look on the life of the individual or animal as life in its totality, for their structures are the aggregation of living units arising from cellular evolution. This evolution embraces essentially different phenomena, some being chemical, others mechanical, so that it is

imperative to distinguish between the stage of life which may be considered as life in the fullest degree, that is, the ultimate result of cellular evolution, and that life of each elemental unit which goes to constitute the grander and more perfect organism, for it is not a matter of degree but of kind. The phenomenon of life is one of those mysteries which many have attempted to explain, and the origin of which still remains a secret feature in the scientific world. All that we can be definitely told is that the phenomenon has its origin in a protoplasmic element, the workings of which have to a certain degree baffled the researches of those who have sought to explain them. It is an oft-quoted axiom that *omne vivum ex vivo*—"all life originates from life"—consequently, although it is granted that the protoplasmic element is endowed with vitality, a difference of opinion exists, as to the method it adopts in the exercise of its functional power of amplification for the purpose of building up the material being.

The term "protoplasm" of itself has given rise to no small confusion, on account of the indiscriminate use made of the term by various writers. It has been made to "differentiate substances essentially diverse, to define matter hard and soft, to elucidate solids and liquids, coloured and colourless, opaque and transparent; it has been used as an explicative of matter granular and destitute of granules, of matter showing structure and structureless, moving and incapable of movement, active matter and passive matter, contractile and non-contractile, matter growing and incapable of change, animate and inanimate."<sup>(18)</sup> Therefore it has been suggested, that the use of the term be abandoned on account of this indefinite and vague manner in which it has been employed, for thus having been associated with such mistaken views, it has been regarded as more misleading than useful<sup>(19)</sup>. Yet the term is requisite when speaking about the constituent parts of the cell, and notwithstanding the erroneous views investigators have made it answerable for, it is the only term recognised scientifically and continued in use. In applying the term, there is one stipulation, however, and it must not be forgotten, it is this: the word "protoplasm" is a morphological term, and must not be understood to convey the idea of, or designate, a definite chemical compound.

The protoplasm of unicellular organisms and of animal cells appears as a viscid substance, colourless, and incapable of mixing with water, while its weight is greater than that of water. It contains certain granular bodies, chlorophyll spots, and often crystals, nuclei and objects of observation embedded in the colourless and apparently structureless mass. Accordingly, whether there are

<sup>(18)</sup> "Protoplasm." (L. S. Beale. London, 1870.)

<sup>(19)</sup> Flemming: "Zellsutstanz, Kern und Zelltheilung." Leipzig, 1882.

<sup>(17)</sup> "Protoplasm: Life Force and Matter." Lionel S. Beale, M.D., F.R.S. (1870).

present few or many of these granular substances in the protoplasmic mass, it becomes more transparent or hyaline, or darker and more granular in appearance, and on this account it has been deemed advisable to distinguish the kinds of protoplasm, as *ectoplasm*, or *hyaloplasm*, and *endoplasm*, or granular plasm. The ectoplasm has been considered as a peripheral layer, and is a specially differentiated organ of cell-structure, endowed with special functions, and there apparently exists considerable truth in this assumption from an experiment performed by Hertwig on some ripe eggs of *Rana temporaria*. He carefully pierced with a glass needle the eggs which had entered the oviduct, and were surrounded with a gelatinous coating, the puncture not being visible, nor the yolk matter able to exude. Sometime after fertilization had taken place, yolk matter began to exude

through the puncture, and to form a ridge between the membrane of the egg and the yolk. This swelling out was caused by the act of fertilization, for the entrance of the spermatozoon has the property of stimulating the surface layer to contract energetically. Hence the piercing must have caused a wound in the peripheral layer, which had not time to heal before the fertilization took place, and through which the yolk only pressed out after the contraction caused by fertilization had set up. A considerable time having ensued between the piercing of the eggs and the act of fertilization, the experiment apparently demonstrates that the peripheral layer possesses a structure differing somewhat from the rest of the cell contents, and also that it possesses properties peculiar to itself <sup>(20)</sup>.

(To be continued.)

## FOSSIL BACILLARIA IN NEW JERSEY.

BY ARTHUR M. EDWARDS, M.D.

AS it led to my studying and so finding the true origin of freshwater layers of Diatomaceae, I may herein set forth the finding of fossil remains of bacillaria in New Jersey, U.S. It will also tend to show how those atomics came about, also how and when their beginning became. I will therefore state just how I recognized and lived almost upon one of those layers which I had for years been gathering from different quarters of the globe.

It was in 1890 that I discovered this deposit about four miles from Newark, in New Jersey, where there was then in construction a railroad, a branch of the Lehigh Valley Railroad, that was to run from Plainfield to Jersey City, to connect the main road with New York. At this point it was laid across two lakes, one unnamed, the other Weequahick Lake. This is an old Indian name for a small lake at the head of Bound Creek, which separates Essex from Union County in New Jersey. Weequahick Lake is in the longest diameter, the south-west, about three quarters of a mile long, by one quarter of a mile broad. It has high gravel hills around it, except at one entrance, where it empties by Bound Creek into Newark Bay, and so into New York Harbour. It is marshy in some places, very shallow, with open water at the head and in the centre. The coast of New Jersey is sinking, and eventually the brackish water will flow into the lake from the north-west, but the coast has previously been down once at least, and salt-water and diatoms, or bacillaria, as they are more properly called, have flowed in. Part of the embankment of the railroad sank and crowded up the bottom of the lake,

forming a ridge six or seven feet high along the road bed. This I found to be made up of two layers, the lowest consisting of freshwater bacillaria with shells of mollusca. The uppermost bed was made up of the same salt water mud found in the meadows between Newark and Jersey City, and contained salt-water bacillaria. Beneath them all was the gravel of the glacial moraine which prevails here. This does not contain any bacillaria, and is composed of coarse gravel with boulders interspersed. The freshwater strata in this locality were at least eight feet thick, and made up of the usual fluviatile forms. Upon this was a layer of freshwater mollusca. Then came a mixture of freshwater and salt-water forms; and above all the layer of salt-water types. On the top, now forming, were freshwater forms which are now living.

From the examination of this and other strata in New Jersey, I have come to the conclusion that the land was first covered with ice, and as this receded, streams were formed of icy water which brought down clay. In this icy water bacillaria multiplied and formed the infusorial earth of the older microscopists. In certain places depressions were formed in the gravel, in which the clay accumulated, and these are known in New Jersey as "kettle holes." In Massachusetts they are known as "dungeons," being often several miles across, and are very common; but they were only on the edge of the ice. So we can know where the edge of the ice came, by noticing where the "kettle holes" and lakelets exist now. There

(20) "The Cell. Outlines of general Anatomy and Physiology." By Oscar Hertwig (London, 1895.) p. 15.

have been several theories of the origin of these "kettle holes," but it seems to me the most plausible is that they are where the water appeared upon the ice, and rushed down to the bottom at the edge where the ice was most porous. This will account for their appearance on the edge of ice—for at that point it was most porous—and not in the glacier itself. It will also account for the depressions occurring occasionally, though rarely, as they do in New Jersey, without clay at the bottom. In this case, as at the famous Ship Hole in Union county, the ice which then existed must have been very thick, and the stream of icy water which formed the Ship Hole must have rushed down with extreme velocity so as to wash out the clay which forms the infusorial earth of other "kettle holes." When the ice ordinarily melted there was a layer of clay settled on the top of the glacial moraine. Then came a sinking of the coast, and the sea water and consequent mud flowed in with marine bacillaria which covered the freshwater forms that had accumulated in the Champlain age. This subsidence took place more than once, as is shown by the marine bacillaria in the meadows of Newark being in at least two layers.

Newark, New Jersey, U.S.A.

### COLORATION AND VARIETIES OF MOLLUSCA.

IN Mr. A. E. Boycott's paper on the "Coloration and Variation of British Extra-marine Mollusca" (which I hope will be published in pamphlet form), he writes: "I suppose the preference which *Tachea (nemoralis)* shows for road banks over those in fields is because of the greater abundance of varied and coarser herbage on the former, while the latter are very grassy and, which may also have its effect, more eaten over by cattle." But does *nemoralis* need or desire a very varied or luxuriant diet? If so, why is it so common on sandhills? Another explanation was suggested by me in a paper in the "Malacologist" last July: "One might have thought that the less amount of cover and the greater amount of enemies to be found close to the roads, in comparison with field hedges, would have reversed the position of affairs. But it seems to me that the dust of the high road provides lime, so conveniently comminuted for the building up of their shells, that they have been drawn, so to speak, into public life by its advantages."

(REV.) J. W. HORSLEY.

St. Peter's Rectory, Walworth, S.E.

[Is it not probable the reason for this habit is that because of the frequent human passers along the roads there are fewer thrushes and blackbirds than in the field hedge-rows, so the *Tachea* have less chance of being eaten by them? May not the crepuscular habit of feeding at dusk, when these birds are least active, have a similar origin?—ED. S.-G.]

### THE MILD WINTER.

THIS winter of 1897-98 appears to be one of the mildest that has occurred in Britain for some years past. It may be well, therefore, to place this fact on record for future reference.

In the South of England especially, the absence of frost has been remarkable, and from many places we have received observations of a late autumnal second flowering of ornamental and fruit trees in sheltered gardens. Laburnum trees have, in isolated cases, produced flowers all through this winter, and to-day (January 21st) I saw a bunch of freshly-gathered laburnum flowers which came from a London suburban garden. In the columns of this and other magazines, and frequently in the newspapers, have been noted instances of winter inflorescence of quite a number of plants. In many gardens wallflowers, marigolds, polyanthus, auricula and such like spring flowers have been in bloom during January in company with Christmas roses (*Hellebore nigra*) and hepaticas. A good many stragglers from autumn flowering species of familiar garden plants have bloomed uninterruptedly since July last, one notable case being the snapdragons. In the woodlands of Kent and Surrey it is by no means difficult to gather a bunch of primroses. These winter primroses are not nearly so large as those of the spring months. They, nevertheless, are of good colour and fragrant perfume.

Birds' nests containing eggs have been recorded both in December and January. I strongly suspect that there are already eggs in some rookeries, also in starlings' and sparrows' nests. Herons in one heronry I have observed appear to be preparing their nests, if they have not already eggs.

Hibernation of some of our land shells has been more than usually incomplete. This applies to such as *Helix virgata*, *H. caperata*, and *H. cantiana*. The first of these, as we have recently been reminded in these pages by Mr. Arthur E. Boycott, in his admirable article on "Coloration and Variation of British Extra-Marine Mollusca," appears to be more or less active most winters, but this year they are exceptionally so. The season has in fact been an excellent one for studying nature.

The entomologists, however, may look depressed in view of a scarcity of insects next summer. This open weather favours the predatory natural enemies of insects. Among these may be counted earwigs, mice, insect-eating birds, and others. As these enemies are more or less active, and therefore in search of food during an open winter such as this, they destroy an enormous number of ova, larvæ and pupæ which if frost-bound for a like period would be safe from their ravages.

J. T. Carrington.

## COLORATION AND VARIATION OF BRITISH EXTRA-MARINE MOLLUSCA.

BY ARTHUR E. BOYCOTT.

(Continued from page 228.)

WE may now pass on to the aquatic species<sup>(1)</sup>. Here we find a few brightly-coloured forms, *Dreissena*, *Anodonta*, *Unio*, *Neritina*, *Paludina* and certain forms of *Sphaerium* (e.g., *S. cornutum*, var. *vittata*) and of *Pisidium amnicum*, with a large majority with thin, horn-coloured, transparent shells, without, as a rule and normally, any bands or other markings; *Segmentina*, "*Planorbis*," *Aplexa*, *Physa*, *Amphiteplea*, *Limnaea*, *Ancylus*, *Velletia*, *Bithinia*, *Valvata*, with *Sphaerium* and *Pisidium*, and perhaps also the semi-amphibious genus, *Succinea*.

To consider these, it is necessary to glance at the origin of the freshwater molluscan fauna<sup>(2)</sup>. It is a generally accepted fact that they have been derived from marine forms by three possible methods: (1) by direct migration up rivers; (2) by inclusion of large or small areas of the sea, as salt-water lagoons, which gradually become fresh; (3) by migration across the littoral, and subsequently changing a terrestrial for an aquatic habit. In the same way landsnails are derived from marine forms by (1) taking to a terrestrial from a freshwater life; (2) directly from the marine species. It is a matter of very great interest, and also one of considerable difficulty, to show the ancestors and path of migration of our land and freshwater mollusca, and this is not the place to enter into the problem at any length. There are certain points, however, which directly bear upon the subject in hand, and must accordingly be mentioned very shortly.

It is well known that many freshwater animals have undergone a developmental modification; the details of the process vary, but the result is that any small, weak, free-swimming larva is done away with, and with it the danger of the species being swept back again into the sea by strong river currents. Some of the best-known examples of this are: the parasitic glochidium larvae of *Anodonta* and *Unio*<sup>(3)</sup>, the development of *Astacus*, in which the *Zoea* and *Nauplius* stages generally found in marine Crustacea are slurred over, and when the young crayfish first leaves the egg,

which is securely attached to and carried about by the mother, it is sufficiently developed and strong enough to cope with ordinary streams; the medusiform person in *Hydra* is reduced to a mere gonadial excrescence on the hydriform person<sup>(4)</sup>.

As a sort of corollary on these facts, W. J. Sollas<sup>(5)</sup> and K. Semper<sup>(6)</sup> have argued that no marine form could spread up a river from the sea by means of its free-swimming larva, which in the sea affords the chief means for its dissemination; for the rough water and strong currents which exist at the mouths of most rivers, especially where a bar is well formed, would effectually prevent the passage up the river of anything with such feeble swimming powers as an ordinary larva. There is doubtless a good deal in this objection, especially when we take into account the strong inducements there are for mollusca to pass up rivers (which will be considered below), and the fact that the freshwater mollusca are, on the whole, an exceedingly well-defined group. That it is not absolute is, I think, shown by various facts which have been observed in freshwater forms which live in currents. There is no doubt that, while the general rule holds good that freshwater forms develop without a metamorphosis, there are not infrequent exceptions to be noticed. Thus freshwater medusae are known,—the famous *Limnocodium sowerbii* at Regent's Park, and *Limnocnida* from Lake Tanganyika; and a third (*Hiatomis lacustris*) has been described by J. v. Kennel, from Trinidad, living in a small freshwater lagoon, with a mixture of Polychaeta and *Mysis* with frogs, *Chaetogaster*, *Planorbis*, *Physa*, and freshwater plants<sup>(7)</sup>. Again, among the Crustacea<sup>(8)</sup>, *Apus*, *Branchipus*, *Estheria*, *Cypris* and *Cyclops* are freshwater species, but have a free larva, while *Cypridina*, *Nebalia*, and *Diastylis*, e.g., are marine, but have no free metamorphosis. The freshwater Polychaet, *Lumbriconereis*, has a free-swimming trochosphere. E. Korschelt<sup>(9)</sup> has shown that the freshwater *Dreissena* has a free-swimming larva. It has been

(1) In a case like the present, where the question of habitat is all important the division into terrestrial and aquatic is not objectionable.

(2) On the whole of this question, see the valuable papers of A. H. Cozke, in "*Conchologist*," II. (1872), pp. 41, 46, and in *Cambr. Nat. Hist.*, iii. (1895), pp. 11-22, and of W. J. Sollas in *Sci. Trans. Roy. Dublin Soc.* (2), iii., pp. 27, foll., also A. M. Marshall, "*Biological Lectures and Addresses*," (1891), pp. 79, foll., and L. C. Miall, *Address to Section of Zoology, Brit. Assoc.*, in "*Nature*," lvi. (1892), p. 492.

(3) For some interesting observations on Glochidia, see O. H. Letter, *Proc. Zool. Soc.* (1891), pp. 52-55.

(4) A. M. Marshall: *Studies Biol. Lab.*, Owens Coll., (1886), i., pp. 324 foll. E. R. Lankester: *Art.*, "*Hydrozoa*," in *Encycl. Brit.*, reprint (1891), p. 61. It is only fair to mention that Klemmberg and F. M. Balfour do not hold the same view.

(5) *Loc. cit.*, p. 89.

(6) "*Animal Life*," (1890), pp. 149, 279.

(7) A. N. H. (6), viii. (1891), p. 259.

(8) Much of this information has naturally been derived from Fritz Müller's "*For Darwin*," *Trans.*, W. S. Dallas (1869), and F. M. Balfour's "*Comparative Embryology*," (1880-1).

(9) A. N. H. (6), ix. (1892), p. 157.

ascertained that the adults here possess some small powers of locomotion. Reichel<sup>(10)</sup> states that in winter they retire into deeper water, and Korschelt has seen them climb up the sides of an aquarium by means of their foot, and very slowly. But its main mode of dissemination over long distances, at any rate where it cannot be carried about on convenient timber and barges, is no doubt by means of this larva; and it spreads and lives in currents of very considerable rapidity<sup>(11)</sup>: thus in the watermains of Paris nine species (including three hitherto unknown ones) have been found<sup>(12)</sup>; and they have been seen in large numbers in a similar situation in London<sup>(13)</sup>. These instances tend to show that an apparently very weak larva may escape being swept away by strong currents, and is capable of progressing against them. Some small freshwater animals (e.g., *Cyclops*) can resist the current of a suction-tube in a much more efficient way than might be supposed.

The animals given above do not all live habitually, or even as a rule, in streams, many regularly inhabiting ponds and quiet waters. It is very possible that some of them have been derived from marine ancestors by the conversion of shallow, continental seas into freshwater lakes, and by the inclusion of small or large areas of salt water as freshwater lagoons. W. J. Sollas is of opinion that this is the means by which the freshwater fauna has been derived: and this is very probably the case, though the probability of some direct migration up rivers must not be excluded.

It is very interesting to note certain examples where these processes seem to be going on at the present day. In the Baltic, between Dragö and Papenwick, *Mytilus edulis*, *Cardium edule*, *Tellina balthica*, *Mya arenaria*, *Littorina rudis* and *Hydrobia balthica* live with *Unio*, *Sphaerium*, *Neritina*, *Limnaea* and *Bithinia* (Braun.). At Stockholm *Cardium*, *Tellina*, *Limnaea peregrina* and *Physa fontinalis* live together (Lindstrom). Near Gothland *Limnaea* is found in the open sea at eight to twelve fathoms, with *Cardium* and *Tellina*, and in the Frische Haff *Mya arenaria* lives alone of marine species, with *Limnaea* (6), *Physa* (1), *Planorbis* (9), *Ancylus* (1)

*Valvata* (4), and *Sphaerium* (Mendthal), 2<sup>(14)</sup>. It is well known that *Neritina fluviatilis* lives in quite salt water with *Mya arenaria*, e.g., in Loch Stennis, Orkney<sup>(15)</sup>. The Baltic, where all the marine and freshwater forms mentioned flourish together, is still connected with the sea; but there are several examples known where inland bodies of water show an admixture of marine and freshwater mollusca. The Caspian is one of them. There we find *Neritina*, *Bithinia* and *Planorbis*, with *Micromelania*, *Caspia*, *Clessinia*, *Nematowella*, all of which are modified forms of the marine *Rissoiidae*; and among the Lamellibranchiata there are *Anodonta* and *Dreissena* with *Adacna*, *Didacna*, and *Monodacna*, which are derived from *Cardium edule*, which also occurs. In Lake Tanganyika<sup>(16)</sup> several of the freshwater genera have a distinctly marine facies, such as *Tithobia*, *Neothauma*, *Limnotrochus* (which possesses all the outward aspect of the marine genera *Trochus* and *Echinella*), *Synolopsis* (like *Obeliscus* or *Syrnola*); *Planorbis*, *Paludina*, *Physa*, *Unio*, etc., also occur. The elevation of Lake Tanganyika is now 2,700 feet above sea level<sup>(17)</sup>, and its connection with the sea must have been in very remote time. It is curious that the fauna of the Victoria Nyanza (altitude, 3,900 feet), which belongs to the same lake system, "appears to be quite Nilotic, and no such remarkable forms as occur in Lake Tanganyika have as yet been met with."<sup>(18)</sup> Indeed, Pelseneer goes so far as to deny any marine appearance in the Tanganyika fauna.<sup>(19)</sup> Quite recently a special expedition has visited these lakes to examine the fauna. I have not yet seen the full results, but according to short notices which have appeared in several journals<sup>(20)</sup>, J. E. S. Moore has determined that some of the Crustacea and other groups are of a distinctly marine type.

Cases illustrating the transition from aquatic to terrestrial forms are also known. Thus W. A. Herdman has shown that *Littorina rudis* actually lives better in air than water<sup>(21)</sup>, and in Jamaica A. H. Cooke has found several species of the same genus living away from immediate contact with the sea, in trees, etc. *Littorina* is also very resistant to desiccation<sup>(22)</sup>. *Neritina*, too, lives sometimes on land as well as in fresh or salt water. What, exactly, the curious pulmonate *Onchidium* is doing seems doubtful. *Limnaea* offers at least one example where we have freshwater amphibious mollusca,

<sup>(10)</sup> Zool. Anz. x. (1887), p. 481. J. Frenzel (Biol. Centralbe, xvii. (1897), p. 147; Journ. Roy. Micr. Soc., April, 1897, p. 117) maintains that colonies can move about *en bloc* without separation of individuals; they thus move into deeper water in cold weather. Movement is effected by the younger members of the colony (in which the foot is not yet atrophied), by (1) fixing the foot and drawing their body after it (as in *Anodonta*); (2) by pushing with their foot behind; and (3) by flapping their valves.

<sup>(11)</sup> Cf. H. W. Kew, "Dispersal" (1893), p. 217.  
<sup>(12)</sup> "Revue Scientifique" (3), xxvi. (1893), pp. 531-534: a review of M. A. Locard's "Malacologie des Conduites d'eau de la Ville de Paris." Conchologists who have had any experience of modern French workers, and especially M. Locard, will understand how to take the large number of new and separate "species."

<sup>(13)</sup> Brit. Conch., i, p. 48.

<sup>(14)</sup> I take these examples from A. H. Cooke, "Conchologist," ii. (1893), p. 42.

<sup>(15)</sup> J. McMurtrie, quoted by R. Rimmer, *op. cit.* p. 24.

<sup>(16)</sup> See E. A. Smith in Proc. Zool. Soc., 1880, p. 344, and 1881, pp. 276 and 558.

<sup>(17)</sup> C. Reid, "Natural Science," i. (1890), pp. 117 foll.

<sup>(18)</sup> E. A. Smith, A. N. H. (6), x. (1892), p. 152, Proc. Zool. Soc. (1877), p. 712.

<sup>(19)</sup> See "American Naturalist," xxi. (1887), p. 288.

<sup>(20)</sup> e.g. Nature, lvi. (1897), p. 198.

<sup>(21)</sup> Proc. Liverpool Biol. Soc., iv. (1890), p. 50.

<sup>(22)</sup> Camb. Nat. Hist., iii. p. 20.



while some members of the genus (*Limnaca stagnalis*) are quite aquatic. *L. fulustris* will often crawl out of an aquarium and live for some time without any moisture, and *L. truncatula* is really more a terrestrial than an aquatic species. As far as my experience goes the latter species is much more often found sitting just outside the water on the mud than submerged. It also possesses wonderful powers of resisting drying up, which, as it is frequently found in the merest trickle of water, must often be of use to it<sup>(24)</sup>. It looks very much as if *L. truncatula* were migrating one way or the other; either leading allied forms out of the water, or following them from land to an aquatic habitat.

It is quite an open question whether the land mollusca are immediately derived from freshwater or marine species. *Littorina* and *Neritina* give some weight to the view that some, at any rate, terrestrial forms have had their immediate ancestors in the sea; while *Limnaca* might be held to point the other way. It seems a not uncommon opinion that, while the terrestrial operculate forms may very likely have come from the sea, the Helicoidea are of freshwater origin. T. H. Montgomery<sup>(24)</sup> makes the general statement that "land forms are derivatives of freshwater forms in all those groups of the Invertebrates which are of marine origin, e.g., the land pulmonate mollusca." Perhaps these views are upheld by the fact that while the lung in *Cyclostoma* and *Limnaeidae* is a modified gill-cavity and retains a trace of the lung-stuff in the adult, in the Helicoidea there is no such trace, and it has been held (Von Ihring; not Semper) that the lung-cavity here is not homologous with that of *Limnaea*, but is a dilatation of the duct leading from the excretory pore to the exterior<sup>(25)</sup>. On the other hand, it is difficult to see how *Limnaca* came to abandon a branchial for a pulmonate mode of breathing if it has never passed through a terrestrial stage, which would have compelled it to do so. W. J. Sollas<sup>(26)</sup> says: "The Helicidae are amongst the nearest allies, and are probably ancestors of the *Limnaeidae*." The genital apparatus of *Amphibulima* (*Succinea*) much resembles *Limnaea*, and "the radula of *Limnaea* also supports the idea that it is derived from some Helicid form" (E. W. W. Bowell)

What is the reason why any marine forms have left the sea and taken to a terrestrial or a fluviatile life? It is undoubtedly due to the keen struggle for existence which goes on in the densely-populated shore waters. There is an extraordinary abundance of life in the shallow waters of the sea. There

are in all probability numerous examples of protective and aggressive modes of coloration to be discovered, though not very many have up to the present been made out. It is plain, for instance, how the general transparency of larval forms must assist them. One of the most interesting cases of this is perhaps the absence of hæmoglobin in *Leptocephalus*, the transparent immature marine form of the common eel. The mollusca no doubt are also engaged in this warfare. They suffer from the attacks of almost innumerable enemies, which will swallow any snail they may come across. J. G. Jeffreys<sup>(27)</sup> gives a considerable list, including sea-birds<sup>(28)</sup>, fish, crustacea, star-fishes, and even other mollusca (e.g., *Buccinum*, *Purpura*), and mentions that the number of the small bivalve *Turtonia minuta* taken from the stomach of a mullet from Lough Larne was estimated by Hyndman at 35,000. Even terrestrial mammalia have been known to destroy mollusca. Rats are very fond of *Patella*, and will eat large numbers<sup>(29)</sup>. Big fish, such as the cod, eat large numbers, and it is said that their stomachs are an excellent hunting-ground for deep-water species, while the walrus feeds almost entirely on *Mya*.

Now the majority of marine species are more or less highly coloured or ornamented; it may be in consequence of the strenuous struggle for existence which is constantly going on. On the other hand, only a certain number of cases of coloration have been assigned to the usual causes—epigamic, sematic, or cryptic<sup>(30)</sup>. A. H. Cooke has pointed out that *Strombus mauritianus* and *S. luhuanus* closely resemble the genus *Conus* in general appearance. *Conus* is a carnivorous genus with large teeth with which they can inflict severe and poisonous wounds, while *Strombus* has weak teeth and is as inoffensive as mollusca usually are. It is hence probably protected by mimicking the more offensive genus, *Conus*<sup>(31)</sup>. Examples of protective colouring are found in several instances. H. L. Osborn<sup>(32)</sup> describes how *Ovulum uniplicatum* varies between yellow and red (shell and mantle), according as it lives among yellow or red *Leptogorgia*. He is of opinion that there is really vastly less mimicking in the sea than on land. Certain points in this matter of shell-colours have been carefully studied in some marine genera (*Voluta*, *Strombus*, *Conus*), by Maria

<sup>(27)</sup> "British Conchology," i. p. lx.

<sup>(28)</sup> W. A. Durnford attributes the great diminution in numbers of cockles and mussels in Morcambe Bay to the increase in the sea-birds consequent on protection by Act of Parliament. Journ. of Conch. iii. p. 76.

<sup>(29)</sup> A. H. Cooke, *op. cit.*, p. 57 and pp. 56-74 generally, on this subject.

<sup>(30)</sup> I refer here only to cases where the colouring is in the main of the shell. Some most interesting cases of protective mimicry have been pointed out among the Nudibranchiata, etc., especially by W. Garstang, Journ. Maine, Biol. Assoc., N.S., i. (1899), pp. 173 and 399; "Conchologist," ii. (1893), p. 49; W. A. Herdman, Q. J. M. S., N.S., xxxi. (1896), p. 41, and Proc. Liverpool Biol. Soc., iv. (1899), p. 159.

<sup>(31)</sup> "Science," vi. (1885), p. 9.

<sup>(32)</sup> Proc. Camb. Soc., viii. p. 41.

<sup>(24)</sup> See, e.g., A. P. Thomas, Q. J. M. S., xliii. (1888), p. 99; T. R. Walker, "Conchologist," i. p. 8.

<sup>(25)</sup> "Derivation of Freshwater and Land Nomenclature," Journ. of Morph., xi. (1895), p. 481.

<sup>(26)</sup> "American Naturalist," xix. (1885), p. 1110.

<sup>(27)</sup> *Loc. cit.* p. 104.

von Linden<sup>(83)</sup>. She comes to the conclusion that sculpturing and markings on shells are not useful, and hence have not arisen by natural selection; but that they are the inherited effect of external conditions, this being, as Eimer says, an efficient cause. The similarity between shell-colour and algae of similar habitat is the result of like physico-chemical conditions, and she very rightly points out that during life, algae, etc., often quite conceal the surface of the shell, not only in mollusca, but also in crustacea, etc. Similar views were expressed by C. Darwin<sup>(84)</sup>. Talking of the beautiful colours of many shells, he says: "The

colours do not appear in most cases to be of any use as a protection; they are probably the direct result, as in the lowest classes, of the nature of the tissues, the patterns and the sculpture of the shell depending on its manner of growth." Whichever general view we take of the colours—whether useful or useless—the fact remains that marine mollusca are as a rule possessed of a more or less elaborate system of coloration or ornamentation, or both; I am inclined to agree with those who attribute this to the action of natural selection.

(To be continued.)

## THE PHYSICAL STATE OF MARS.

By COLONEL H. S. KNIGHT, F.R.A.S.

I HAVE read Mr. Oswald's paper in SCIENCE-GOSSIP of August, 1897, upon "The Physical State of Mars," and though the article is written with so much ability, there are some statements to which I would take exception as not agreeing with my own observations. In the first place, the writer mentions that the atmosphere of Mars is one of extreme tenuity, and he treats this as an explanation for the absence of clouds, except to a very slight extent. I enclose a small sketch of Mars as I saw it upon one occasion, which proves that this planet may be very cloudy at times. I think it also settles the question of absence of water from the greater part of its surface. Again, it is a well-known fact that its Polar ice-cap has by no means the permanence it holds on our earth, although its seasons are of much longer duration. Now the force developed by any matter depends chiefly on its mass. Thus, when we find heat developed on the surface of Mars, it is a proof that its atmosphere must be extensive. When the reverse is the case on our earth, near or even within the tropics, the snows on high mountains last through all time, although seldom renewed, because on them the air is rare. Mars being much more distant from the sun than the earth, therefore, should have a colder climate. With an equally dense atmosphere in Great Britain, we are enveloped in mists, producing an obscurity in our atmosphere which does not exist in dry

continents such as in the Indian section of Asia, especially in its north-west portion, where the atmosphere is incomparably clearer.

With regard to the remark that there are no mountain ranges in Mars, we must bear in mind its great distance from the earth. The altitude of our highest mountains is comparatively trivial, and only reached after many miles of rise from sea-level, and, as observed from Mars, would appear flat land. Someone observing Mars with a good telescope on the Andes not only saw mountains, but observed them covered with clouds which deposited snow on them, and this snow remained several days in view, and then gradually disappeared. Where there is snow, there must be sufficient cloud formation to produce rain, and also much water on the surface of Mars to produce clouds, or even cause a deposit of frost. Thus in the dry climate of Ladak frost is unknown, although the winter temperature falls much below freezing, and this place is only about 11,000 feet above sea-level.

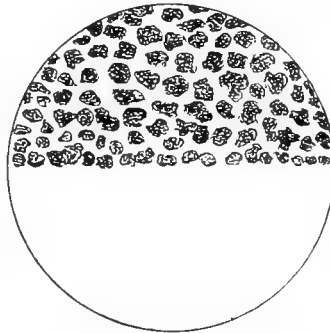

CLOUDS SEEN ON THE PLANET MARS.

I have never observed "canals" on Mars, although I have seen its ice-cap and dark border very distinctly. I have seen reddish and buff-tinted clouds, which gave me the idea of Indian and North African dust storms. When the slight nature of the Polar snow-cap is considered, it is difficult to conceive that canals could convey water for thousands of miles towards its equatorial region, and in such a dry climate, even if we leave out the machinery necessary to force the water over such distances, for it is clear it would not flow otherwise.

The Observatory, Harestock, Hants.

<sup>(83)</sup> Zeitschr. f. wiss. Zool., lxi. (1896), p. 261; abstract in Journ. Roy. Microsc. Soc., 1896, p. 303.

<sup>(84)</sup> "Descent" (1890), p. 263.

## THE ROCKS OF THE ISLE OF MAN.

BY FRED. J. GRAY.

*(Continued from page 222.)*

## EXCURSION TO FOXDALE.

**A**T Foxdale the Silurian slates are intruded by a granite "boss," called Dun Howe, which has a height of 757 feet above sea level. This lies to the south-east of Foxdale, and it is pierced by the Foxdale lead mines. At this village there are some immense tips of granite of many varieties brought out of the mines, and I was able to obtain a good number of specimens. The principal kind is a light-grey granite composed of white felspar (albite) quartz and mica (muscovite, chiefly). When first brought to the surface, it is exceedingly hard, having to be blasted, but some of it does not weather well, as I saw much which I was able to crumble in my hand. It is, in fact, composed simply of quartz grains and kaolin, the latter being decomposed felspar. The stone is, however, used considerably in the neighbourhood for building purposes, and appears to stand fairly well. The little church at St. John's is built of the white variety, which has weathered to a dull grey.

This granite varies in many respects, some is red, other pink, green and yellowish green. As I have said, one kind is hard, another soft and crumbly. Some are close-grained, even holocrystalline rocks, others being coarse-grained, intersected by bands and veins of a greenish mineral. Quartz veins, too, are of common occurrence, one of my hand specimens being a yellowish green granite with a quartz vein about an inch wide running through it. The rocks containing the green mineral soon decompose, this mineral apparently being the cause, turning first brownish green, then red or deep brown. A great amount of it eventually looks like pieces of old dirty brick; it is as rotten as the white variety previously mentioned.

The mineral greisen is also found in connection with this "boss." It is composed of quartz and muscovite, in some parts evenly commingled, and in others the mica is moulded on the quartz, which is the white massive variety.

A microscopic examination of the white variety of the Foxdale granite shows it to be a holocrystalline aggregate of quartz, felspar and mica as essential minerals, and garnet, zircon and apatite as accessories. The quartz is glassy and exhibits the usual strong polarization colours. It generally contains many inclusions, amongst which needles of apatite and zircon crystals are fairly numerous, while cavities and negative crystals with bubbles, etc., are very common. Schiller-like

inclusions, or micro-dendritic growths, too, are present, filled with a black opaque mineral, probably pyrites. The quartz, being the last product of consolidation, is never found idiomorphic, but fills up the interstitial space.

The felspar, as I have already observed, is chiefly "albite," and exhibits examples of twinning on the "polysynthetic" system. Some of the felspar is fairly idiomorphic, but most of it is turbid and cloudy, and appears to be much decomposed, no doubt owing to the large percentage of soda in its chemical composition. It is the decomposition of the albite which produces the kaolin and causes the stone to decay. A great quantity of this kaolin is brought up from the mines, both with the solid matter and pumped up with the water. It can be seen to colour the little stream running from Foxdale to St. John's, a mile or two away from the mines. Zonary banding and the pericline system of twinning may occasionally be observed amongst the felspar.

The mica is principally "muscovite," but "biotite" is also present. Some comparatively large plates of muscovite are found, generally longitudinal sections. It is very easy to observe in some of these sections that mica is an early product of consolidation, several flakes being seen broken across, evidently by pressure from the harder minerals which have later crystallized. The accessories, apatite and zircon, principally occur as inclusions in the quartz, but garnets are very common in the holocrystalline base. One or two fairly large ones of a reddish yellow colour were found, others occurring as small patches of a brown spongy nature.

In connection with this granitic "boss," there are many veins of aplite or microgranite, of different colours from grey to yellowish brown, of very fine texture, and containing in some cases plates of mica much larger than the other minerals forming the rock. Some of these veins or dykes have undergone, to a small extent, change of structure, doubtless by pressure, having had a somewhat schistose character set up, similar to the Laxey "trap" dyke previously described. Under the microscope a thin slice of the ordinary aplite is seen to be composed of a granular mosaic of clear quartz and felspar of very small dimensions, throughout which are scattered porphyritic crystals of the same minerals, and large plates or flakes of muscovite, garnets of a spongy nature and a bright red colour also occurring. The mica again proves itself to be one of the first products of consolida-

tion, one flake being almost broken in two, the fracture or rupture not having gone quite through.

The chief matters of interest in this slide are the inclusions contained in the quartz. These are very numerous, and vary greatly in shape. Long fluid pores are seen, needles of apatite, zircons, gas pores, and fluid pores, with bubbles and cavities of all shapes and sizes. Some of the crystal-shaped inclusions resemble zircons, but are constricted in a peculiar way in the middle. A little biotite and pyrites are also found in this rock, its brownish colour probably being due to the latter mineral.

An examination of a thin section of aplite with the schistose structure shows that its laminated character is brought about by the presence of small flakes of biotite, having the usual ragged edges and polarizing in strong reddish-brown and green colours. The rock itself is a similar one to the aplite just described, but the porphyritic crystals do not seem quite so common. Some of the felspar crystals are found twinning on the albite system, and smaller lath-shaped crystals are to be seen in the granular mosaic base of the rock. Reddish-brown and yellow garnets are again present.

The inclusions in the quartz are very interesting. They comprise zircons (some being fairly large ones), glass inclusions, apatite, pseudomorphs of different kinds, schiller inclusions of iron oxide, glass inclusions devitrified, and one or two larger negative crystals containing bubbles and cubes.

Another variety of rock, of which I brought a specimen, appears to be dolomite, or a mixture of dolomite and calcite. A fresh fracture shows this to be crystalline of a light yellowish-brown colour, with fine veins and minute specks of pyrites and lead ore. The weathered surface of it is, however, of a deep reddish-brown, somewhat resembling haematite in colour.

On first examining a thin section under the microscope, I came to the conclusion it was all calcite, and the strong, double refraction, cleavage angle, and general characteristics evidenced such a rock. On making a chemical examination of the hand specimen, however, I found that nitric acid had no effect either on the weathered surface or the fresh fracture. The rock, therefore, could not be composed of calcite, and must be a variety of dolomite.

On making a more careful examination of the slide, I found many comparatively wide fissures, some filled with ordinary calcite, others with amorphous quartz, some with iron oxide, and others containing minute crystals of dog-tooth spar. The main mineral was a clear one, marked with cleavage lines and, occasionally, with large patches of some variety of iron oxide of a strong orange colour.

These observations would tend to show the rock to have been originally a limestone which has undergone a metasomatic change, shrinkage having occurred during the process, which is a common result of dolomitization. The cracks had subsequently been filled with quartz, iron, and secondary calcite of different kinds.

#### MAKING MICROSCOPICAL SECTIONS.

In concluding my remarks on a few of the petrological features of the Isle of Man, I would allude to the rock sections which I have used for the purpose of the examinations referred to in this article. All of these I have myself made by the somewhat slow process of grinding "chips" down with coarse emery on a steel plate. They were then finished off with flour of emery on a sheet of plate glass. Although this process is a somewhat long one, and requires a great deal of patience, yet it has its advantages, enabling one to compare the relative hardness, texture, etc., of the different specimens one may be engaged upon.

The hardest and densest rock which I have mentioned was the quartzite from Port Soderick; but at the same time it was the most satisfactory one, since its exceedingly fine texture kept it from breaking when getting very thin. The normal basalts, too, were very hard, and took a long time to make, but the same remark applies to them as the quartzite. They were, generally speaking, so fine of texture as to be capable of being ground very thin, not breaking up either during the process of grinding, or removal from the "rubbing-glass" to the micro-slide. The same may be said, in a modified tone, of the basalts, slightly decomposed; but the fragmentary rocks were very awkward ones to work. They usually broke up into three or four pieces, when being re-heated and properly mounted, owing to the adhesion between the lapilli and ground base being exceedingly small.

The ordinary granites from Foxdale were the worst rocks of which I had to make slides. They were exceedingly brittle, breaking up in all directions when getting thin and being ground, others breaking when being mounted. Some of them were completely useless, and the manufacture of these slides was by no means satisfactory, this probably being due to the coarse nature of the specimens.

The aplite varieties were rather awkward ones to work, but from another cause. During the process of finishing with fine emery, this was apt to "soak" into the section, which then had to be very carefully washed before being mounted.

The diorite, trap, and pebble sections generally, were good ones to make, being capable of very fine rubbing, and not breaking during fixing.

The easiest slide made was a section of the clay schist from Langness Point. Owing to its exceed-

ingly fine texture and degree of softness, it was necessary for this to be prepared in the way described by Professor Rutley in his "Study of the Rocks." Having ground a chip down to a smooth surface on one side, I mounted it on a cover slip, and that again on a piece of rubbing-glass. When it was sufficiently thin I cleaned it, warmed the glass, and took off the thin slip, with the rock section on

the top, which I mounted in the usual way. It was a good thing I did it this way, as it would never have been capable of removal by itself, some of the specimen crumbling and disappearing altogether during washing. Beyond a few bubbles, however, the slide is a fair one and very interesting.

42, Crompton Street, Derby.

## ORCADIAN RAMBLES.

By ROBERT GODFREY.

(Continued from page 226.)

### III.—STROMNESS TO THE BLACK CRAIG.

NEXT morning, May 27th, I purposed examining the wild-life along shore, and passed beyond the numerous fishing stations, where immense flocks of gulls were congregated, towards the Ness or south-western corner of the mainland. From this spot the scene displayed is magnificent, and our own low-lying shore is so utterly insignificant that it only emphasises the distant view. Across the narrow sound rise the deeply-scarred mountains of Hoy, with a sheer rocky bight at their northernmost point, but at the region opposite the Ness with level pastures, on which we can discern a man ploughing and cattle grazing, adjoining the sea. Between the mainland and Hoy is the highway of the ocean, and a line of herring boats amidst an impressive silence is riding out to sea. Continuously the surging waves break heavily in white foam upon the low rocks, making not uproar but music, and the cool, refreshing breeze fans us gently with its breath. Everything betokens activity, and yet the real centres of activity are not here but elsewhere. Gulls pass us by unheeding, and strings of guillemots with headlong flight hurry through the sound, whilst shags pass singly along the tide-edge. It is pleasant amidst such a general commotion to have one fellow-loiterer beside us, especially when that loiterer is the minstrel lark. At times a bunting utters his curious song, or a wheatear mounts in the air to deliver his, but these, by contrast, only heighten the effect of the minstrelsy overhead.

Wandering on by the low rocky foreshore, we rouse a starling, but pay little heed to such a ubiquitous species, and we soon find ourselves amidst piles of seaweed deposited to dry on the top of the rough stony bank. This is the first indication of kelp-making in progress, and at intervals thereafter we pass small kilns, cavities lined with stones and about two feet deep, in which the burning takes place. Whilst meditating on this industry, now in its period of decay, we are startled by the sharp, shrill whistle of a whimbrel, as it rises from a seaweed covered portion of the

shore, and, following it in its flight, our eyes rest on a large bird diving near the tide edge. Moving warily along in its direction, we observe a beautiful shelduck, with his gaudy display of black and white, pass seawards. Meanwhile, we rest on the grassy slope beneath the seawall, and turn our attention, favoured by the brilliant sun, to the stranger that is feeding in the very region where the waves are breaking worst, diving at the edges of the projecting rocks in search of crabs and such like. We recognize the bird as an eiderdrake in its hideous immature plumage, and, before we cease watching him, note a pair of adult eiders pass northwards. Our retreat is invaded by carts coming for seaweed, and as we continue our journey, we cause the immature eider to swim outwards, though he still displays little alarm.

Along the foreshore here the laminated structure of the rocks render their adaptation for economical purposes a comparatively easy matter, and huge flagstones are lying against the wall ready for transport. In Stromness these flagstones have in many cases been used instead of slates to cover the roofs of the houses, a method of roofing in vogue in Kirkwall and Scalloway as well. A croft inland from this part of the shore is bounded by flagstones set on end, and looks in the distance as if it were hemmed in by tombstones.

Ahead of us now the rising smoke tells of our approach to the kelp-burners, but ere we reach their haunt we have some distance to cover, and intently study the shore for further additions to its life. A single oyster-catcher is feeding in silence—strangely enough, on the low rocks—and rock pipits are delivering their simple songs in the air as they rise from the bank and descend to the seaweed again. We find a dead kittiwake on the shore, and are attracted to a hooded crow by its harsh cry, a bird which one would expect to find much more numerous in Orkney than it really is.

Beyond a churchyard we enter the region occupied by the kelp-houses, a large stretch of grassy ground covered with small heaps of dried

seaweed standing at short intervals apart. Seven fires are in full swing along the edge of the shore, and one attendant at each feeds with fuel whilst as many women as men are employed in loding carts and transferring the seaweed to the scene of operations. At one time kelp-burning was a much more prevalent custom in the Scottish islands than it is now, the fall in production arising from the depreciation of value. Still the process is in operation in many places, and provides work for numerous people throughout the summer. In spring the seaweed is gathered and spread above tide-marks to dry, and in about six weeks it is generally dry enough to burn readily without the aid of other fuel. The fire is laid in the early morning and an attendant keeps up a constant supply of ware and periodically stirs about the mass in the kiln; before night the kelp or residue of the burning has been formed. One of the burners informed me that a ready market is still obtainable for the kelp, and he broke off for me a small piece of the solid finished article. On leaving this centre of kelp-burning we barely escape from the smoke-cloud that follows us ere we see another kelp-centre in full swing further on.

The rocks are very low and grass-clad, skirting a well cultivated region as far as the centre of the bay, from which the ascent to the Black Craig begins; thereafter they assume a wilder aspect and rise to a sufficient height to form an attractive breeding-haunt for sea-birds. Keeping as near the cliff-edge as possible under the strong wind that was blowing, I kept my attention on the cliff-tenants. Starlings were abundant and rock pipits were still singing, but the real tenants did not betray alarm till I was nearer their abodes. Then the herring-gulls left their nests and began that strange uproar that so delights whilst it deafens the listener, whilst a white mass of birds fluttered in front of the rocks and over the sea. Out dashed a pair of rockdoves from near the cliff-head and a number of shags left singly, whilst razorbills, singly or in pairs, followed suit and flew down to the sea or in rapid flight circled round, rising to the cliff-head as if to inspect me and then dashing on again. Small patches of steep, grassy slopes were the favourite haunts of the gulls, and in such regions the birds dotted the surface thickly; the razorbills were secure beneath overhanging ledges. The herring gulls—no other species of gull was here—preferred the spots where more or less soil occurred, though occasionally they occupied little recesses or ledges, and many of the sitting birds were as vociferous as those on the wing. By halting immediately over the sitting birds I easily dislodged them and saw the contents of their nests, and I was greatly interested in watching the readiness with which they seized an opportunity of returning to their eggs.

At a sheer portion of the cliffs where the rocks were rent in many places, a colony of puffins was established, and these little birds, with their bright coral-coloured bills and legs, afforded an elegant display, as they passed to and fro between the sea and the rocks. They showed a special liking for a particular ledge on the rock-face, and on this small piece of rock seven were resting at once. When alighting on the rocks they stood upright with their bodies clear of the ground, or only their tails touching it. They keep their legs perpendicular and walk easily enough, betraying no awkwardness, as in the case of the guillemots. In spite of their gregarious disposition the puffins sometimes displayed hostility to their neighbours, for a bird would often be refused landing room by those already on the ledge, and be compelled to sheer off, or would be driven off even after it had alighted. They fly very rapidly, with a steady wing-beat, and occasionally sail in flight as they approach land; in leaving the rocks they allow their bright coral-like legs to fall out in line with the sides of their tail. The curious manner in which the birds made advances to one another was comical; one would lower its head and stretch out its neck towards another, and the two would wriggle together, whilst a third would endeavour to join in the game. In walking they keep the body clear of the ground and the tail parallel to it; they sometimes rest on the ledges in a cowering attitude, or stand beating their wings sharply. On the whole they were friendly disposed and seemed to take a lively interest in their neighbours, straining their necks to see those on a ledge below, or on one above, and they were in almost constant motion one way or another.

The succession of cliffs abated not in splendour, maintaining their sheer aspect, though they fell off in height. The waves broke impetuously in foam on the sloping green rocks below, and dashed high in white spray, whilst a second white line formed on the sea at some distance from the shore. In addition to the birds already noted, I came on a colony of guillemots occupying a narrow cave-like recess amongst the rocks, and after long search roused a single black guillemot. I did not, however, find any trace of the peregrine falcon, though the rocks are suitable for this bird.

When bird-life began to fail, I left the rocks and turned hillwards to renew my search for the tantalising harriers. The hills were desolate enough for what I sought, and rough enough too, but the heather was short. I rambled for a long time amongst these hills, attended by peeweeep, golden plover, redshank and dunlin; but I eventually reached the crofts above Stromness without seeing the bird I sought.

*(To be continued.)*

## ARMATURE OF HELICOID LANDSHELLS,

WITH A NEW SPECIES OF PLECTOPYLIS.

BY G. K. GUDE, F.Z.S.

(Continued from page 232.)

*PLECTOPYLIS OGLEI* (figs. 68*a-h*), from Sadiya, Assam, was described and figured by Lieut.-Colonel Godwin-Austen in the "Journal of the Asiatic Society of Bengal," *xlvi.* (1879), p. 3, t. 1, f. 2. The shell is dextral, disk-shaped, widely umbilicated, corneous, marked transversely

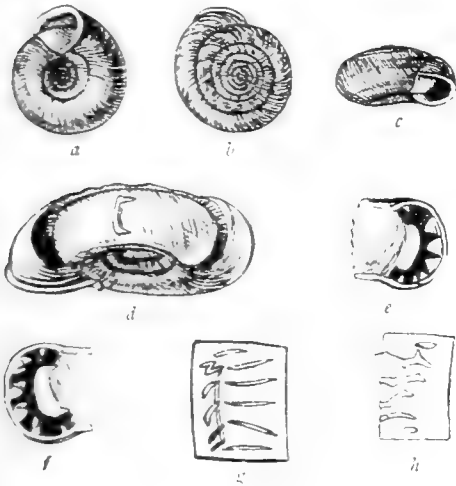
Fig. 68.—*Plectopylis oglei*.

with dark brown, finely and closely striated, the upper side coarsely decussated with raised spiral lines. The spire is scarcely raised, the apex a little elevated, and the suture impressed. There are eight rounded whorls, which increase slowly and regularly, the last being angular above and below, and obsoletely keeled at the periphery, descending slowly in front. The aperture is oblique, roundly ovate, slightly depressed above; the peristome is white, thickened and reflexed, its margins are connected by a scarcely raised curved ridge on the parietal callus, a slight notch being observable above and below at the junctions. The parietal armature consists of a single strong vertical plate, which gives off posteriorly two short ridges, one at the upper and one at the lower extremity (see fig. 68*d*, which gives an enlarged view of a specimen with the outer wall removed). The palatal armature consists of six horizontal folds: the first, near the suture, very short and thin; the second, third, fourth, fifth, and sixth, bilobed or bisected about the middle, where a slight vertical ridge connects their posterior portions, the posterior portion of the second fold is sinuous,

somewhat S-shaped; the third, fourth, and fifth are slightly deflected posteriorly; the sixth is very unequally bisected, the posterior portion being less than a third the length of the anterior portion, which is raised at first and then suddenly deflected (see fig. 68*g*, which shows the inside of the outer wall of the shell enlarged). The illustrations have been made from the type specimens in the collection of Lieut.-Colonel Godwin-Austen, to whom I am under obligation for the loan of them. The specimen shown in figs. 68*a-c* (natural size) measures: major diameter, 27 millimetres; minor diameter, 25 millimetres; altitude, 8 millimetres; figs. 68*e-g* (enlarged), are taken from a specimen not quite full-grown; *e* shows the parietal and palatal armatures from the anterior side; *f*, their posterior aspect; and *g*, as just mentioned, the inside of the outer wall with its folds. This specimen exhibits the remains of a previous parietal plate, one quarter of a whorl behind the permanent one. Fig. 68*h*, shows the inside of a portion of the outer shell-wall of the specimen shown in fig. 68*d*, the armature of which is incomplete, a portion having been broken away. Two immature specimens in different stages of growth exhibit armatures identical in all respects with those illustrated, except that the palatal folds are less bilobed. The species under consideration is allied to *Plectopylis serica*, but it is larger, and presents considerable differences in the palatal armature.

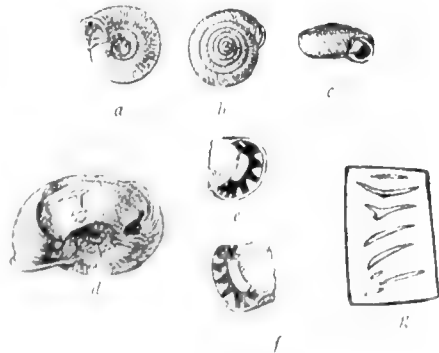
Fig. 69. *Plectopylis munipurensis*.

*Plectopylis munipurensis* (figs. 69*a-g*), from the Ithang Valley, Manipur, was described and figured by Lieut.-Col. Godwin-Austen in the "Proceedings of the Zoological Society," 1874, p. 610, t. 73, f. 6.

The shell is dextral, disk-shaped, deeply and rather widely umbilicated, pale ochreous brown, irregularly marked with a darker shade, regularly and finely striated, with many raised spiral ridges. The spire is depressed-conical, the apex prominent, and the suture slightly impressed. There are seven whorls, flattened above and tumid below, the last scarcely descending in front. The aperture is oblique, a little depressed above, somewhat ear-shaped; the peristome is white, a little thickened and reflexed, its margins being united by a strong, raised, curved ridge on the parietal callus, and notched above and below at the junctions. The parietal armature consists of a single, strong, vertical plate, which is obliquely deflected towards the aperture; it has two slight supports posteriorly—the lower a little deflected, the upper obliquely raised—and gives off anteriorly, at the upper extremity, a long, slightly raised ridge; a minute denticle occurs just below the vertical plate (see fig. 69*d*, which gives an enlarged view of the shell with a portion of the outer wall removed). The palatal armature consists of six more or less horizontal folds: the first very minute near the suture; the second long and descending a little obliquely towards the middle, with the posterior end suddenly raised; the third and fourth also descending a little obliquely, their posterior extremities dilated, almost bifurcated; the fifth also descending a little, its posterior termination suddenly deflected; the sixth, horizontal, with a minute denticle above, and an elongated one a little further back, below the posterior termination of the fold (see fig. 69*g*, which shows the inside of the outer wall of the shell). The figures are taken from the type specimens in the collection of Lieut.-Colonel Godwin-Austen, who has obligingly lent them to me for this purpose. The shell measures: major diameter, 10.5-11 millimetres; minor diameter, 9-9.5 millimetres; altitude, 5 millimetres. Figs. 69*a-c* are of natural size, while figs. 69*d-g* are enlarged; *e* shows the armatures from the anterior and *f* from the posterior side.

*Plectopylis blanda* (<sup>1</sup>) (figs. 70*a-f*). A single speci-

(<sup>1</sup>) *Plectopylis blanda*, n. sp. (figs. 70*a-f*).—Shell sinistral, depressed conical, widely and deeply umbilicated, whitish-corneous, finely and regularly ribbed. Spire conical, apex prominent, suture distinctly impressed. Whorls six, tumid above, rounded below, increasing very slowly and regularly, the last not descending in front, angulated above the periphery and round the wide perspective umbilicus. The cuticle is produced into deciduous hairs on the ribs, forming spiral rows. Aperture oblique, lunate, a little flattened on the upper, outer margin. Peristome white, a little thickened and reflexed, the margins united by a slight, flexuous ridge on the parietal callus. Parietal wall with a strong, vertical plate, slightly deflected anteriorly and having two minute denticles posteriorly, the upper vertically the lower horizontally elongated. A very thin horizontal fold occurs below the vertical plate and a very short fold above it. Palatal folds in two series; the anterior consisting of six thin horizontal folds, the first and sixth a little shorter and placed a little further back than the other four; the posterior series consists of four very short folds or denticles.—Major diameter, 6 millimetres; minor diameter, 5 millimetres; altitude, 3 millimetres. Habitat—Naga Hills, Assam.—Type in my collection.

men received by the writer under the name of *Plectopylis minor*, from the Naga Hills, was sent to Lieut.-Colonel Godwin-Austen for examination, and was found by him to be a new species. It differs from *Plectopylis minor* in being larger and more elevated, and having a wider and deeper umbilicus. The parietal armature differs in having an additional fold above the vertical plate, and the anterior denticles are almost united to this fold. The palatal armature differs in the posterior folds being very short and almost reduced to denticles. Figs. 70*a-c* show the shell in three

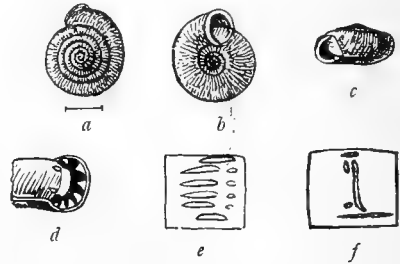

Fig. 70.—*Plectopylis blanda*.

different aspects. Fig. 70*d*, gives the posterior view of the two armatures; *e*, the inside of the outer wall; and *f*, a portion of the parietal wall, with its plate and folds. All the figures are enlarged.

*Erratum*.—A typographical error occurs *ante* p. 231—the name *Plectopylis leucochilus* should read *Plectopylis leucochila*.

(To be continued.)

## THE TOTAL ECLIPSE.

IT is very satisfactory to learn, from a telegram of January 22nd, from Calcutta, that the total eclipse of the sun of that date appears to have been observed in perfect weather conditions at all the stations. The totality lasted one and a-half minutes, during which time the light was about equal to that of the full moon. Very valuable photographs and results have been obtained by various observers. The newest feature among the observing instruments was an application for taking moving photographic pictures, a series of which, taken from a point near Benares, have been secured by the Rev. J. M. Bacon, F.R.A.S. They may prove of extreme value as showing whether in the short space of seconds of totality, any change took place in the shape of the sun's gaseous corona. The films are to be sent to England for development. The machine for taking these pictures was designed by Mr. Nevil Maskelyne. At other stations numerous ordinary photographs have been secured. Telegrams in the "Times" appeared on January 24th, from Mr. E. W. Maunder, Sir Norman Lockyer, and others, giving a brilliant description of the scene.



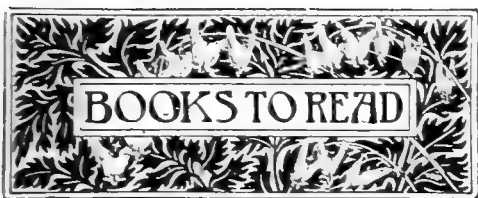

NOTICES BY JOHN T. CARRINGTON.

*By Roadside and River.* By H. MEAD BRIGGS, 204 pp. 8vo, illustrated by frontispiece. (London: Elliot Stock, 1897.) Price 3s. 6d.

The sub-title of this work is "Gleanings from Nature's Fields," and, like the author's former work, "By Tangled Paths," the book must rank as one on country lore, having no pretensions to science. The work is one which will please people who love country rambles and meditations inspired thereby. We reproduce the frontispiece of this prettily printed book.

*Some Phenomena of Nature.* By JAMES WALKER, 232 pp. 8vo. (London: Swan, Sonnenschein and Co., Limited, 1898.) 3s. 6d.

This small work is devoted to the consideration of certain physical factors connected with Cosmos. It deals with matters electrical, with motion, friction, comets, light and heat. Part of the material of the work was written in the form of letters to a newspaper, the rest being an elaboration of a theory suggested by the author, which may be understood on leisurely reading his explanations. In his introduction, he describes it as being "the existence of an all-universal, all-pervading force extending throughout the whole material universe, penetrating all substances, the cause of all change in, and the origin of every relation, alliance or combination of, matter. There can be no doubt that force may exist independently and apart from matter, yet there is no matter existing which is not submerged in and permeated by that force." The author states that its nature and origin, or how, or why it came to exist, no man's mental faculty is capable of comprehending.

*Humanitarian Essays* By various authors. Edited by HENRY S. SALT, 233 pp. 8vo. (London: Wm. Reeves and A. and H. B. Bonner, 1897.) 1s.

This is one of the Humanitarian League publications, being volume iii. of the "Cruelties of Civilization." It is a work dealing chiefly with social subjects, and is therefore beyond our province for criticism. The contents include "The Sweating System," "The Gallows and the Lash," "The Shadow of the Sword," "Public Control of Hospitals," and some other essays on like subjects. There is an old aphorism that the people of the world are made up of all sorts; therefore there must be some who will take pleasure in reading these essays. We find them, however, the emanations of writers who seek to swallow a camel while straining at a gnat. Had civilization been conducted from the beginning on the lines advocated in these pages we fear some races of mankind would have long since died out of their own effete-ness. Such writers appear incapable of seeing more than one side of a subject, and that usually the sentimental one. To those who feel it a duty to read these Essays we would recommend a course of Charles Kingsley to follow as a healthy antidote.



THE RIVER ROAD.

From "By Roadside and River," by H. Mead Briggs.

*An Illustrated Manual of British Birds.* By HOWARD SAUNDERS, F.L.S., F.Z.S. 2nd edition, revised. Parts ii. and iii. (London: Gurney and Jackson, 1897-98.) 1s. each part.

We have already referred to the re-issue of this book (*ante* page 205); unlike some other new editions of ornithological works, Mr. Howard Saunders has carefully revised and brought up to date, with additions, what is known of

British birds. The two numbers before us conclude the Warblers, proceed with the Accentors, the Tits and some others. The blocks are in beautiful condition, the illustrations being quite as sharp as were those of the first edition. The whole work will be complete in twenty parts, and will then form, for years to come, the best manual within reach of all persons interested in our wild birds.

*What is Life?* By FREDERICK HOVENDEN, F.L.S., F.G.S., F.R.M.S., 300 pp. medium 8vo, illustrated. (London: Chapman and Hall, Ltd., 1897.) 1s.

Had this book been issued to the public a century or two ago, it is probable the effluvia from the roasting adipose tissue of the author might have laden the breeze passing over Smithfield. He

would, most assuredly, have perished at the stake. We are not at all sure there are not still existing some good people who would, even now, enjoy a sniff of that perfume. The book is a clever compilation of well-established facts—and some opinions. The sub-titles indicate the contents; they are "Where are We? What are We? Whence did we Come? and Whither do we Go?" We recommend our readers to peruse this work dispassionately and to form their own opinions, and they will, we imagine, be largely assisted by absence of prejudice. The work does not pretend to propound new theories, but it places very plainly before its readers some of those which have resulted from the liberality of thought that has characterised the latter quarter of this century. Although it is probable some of the readers may cavil with portions of his last chapter, it would be futile to disguise the fact that in the work, as a whole, the author represents the tendency of modern thought among thinking people.

*The Flora of the Alps.* By ALFRED W. BENNETT, M.A., B.Sc., F.L.S. 8vo. Parts vii. and viii., with 28 coloured plates. (London: John C. Nimmo, 1897.) 2s. 6d. each net.

This handsome work is now complete, concluding with Part viii., which contains a glossary of scientific terms, index of Latin names and index of English names of Alpine flowers. The work is illustrated by 120 coloured plates, the majority of them excellent likenesses of the plants they are intended to represent. Whether as a travelling companion to mountainous Europe, or for the library, we can recommend this work to both botanists and those travellers who like to know the names of unfamiliar flowers met with on their excursions.

*The Story of the British Coinage.* By GERTRUDE BURFORD RAWLINGS. 224 pp. small 8vo, and 108 illustrations. (London: George Newnes, Limited, 1898.) 1s.

Numismatics rather belongs to archæology than to physical science. Still the subject is an exact science and a very interesting one. This little book is one of Sir George Newnes' "Story Series" to which we have previously had occasion to refer. The two-page preface is useful, as it instructs the uninitiated in the terms used by numismatists. There are four general divisions in the work relating to English, Scottish and Colonial coinage, with a note on Tokens. The numerous illustrations are of much aid to the reader, and are generally good. The author writes pleasantly, and one goes on reading and learning many bits of coin-lore.

*The Journal of Malacology.* Edited by WILFRED MARK WEBB, F.L.S., 60 pp. 8vo, illustrated. (London: Dulau and Co., 1897.)

Some of the articles in this volume will be useful to malacologists, especially the notes on the genus *Testacella*, to which the editor has given much attention. There are six plates in this volume besides some figures in the letterpress.

*Transactions of the English Aborigicultural Society.* Vol. iii. Part iii. 139 pp. 8vo, illustrated. (Carlisle: G. and T. Coward, 1897.) 1s.

This part contains the President's address to the sixteenth annual meeting, and articles on "Town and Suburban Planting," "Hedges and their Management," also, "General Forestry." Not the least interesting portion is the report on the Society's visit to Sandringham.



ERNEST HART was born in London in 1836, and died on January 7th, 1898, at Brighton. Mr. Hart was in early boyhood bright and intelligent, soon showing at the City of London School a faculty for prize-winning. He was brought up to the medical profession, walking St. George's Hospital. Mr. Hart was admitted a member of the Royal College of Surgeons in 1856, and received the appointment of Resident Medical Officer at St. Mary's Hospital, Paddington. Although Mr. Hart gave much attention to ophthalmology and aural treatment, he was not destined to make his name by the exercise of his profession. He devoted himself early to its literary side and joined the staff of the "Lancet," which journal for some time secured his services. That work led to his being appointed editor of the "British Medical Journal" in 1866, which post Mr. Hart held to the end of his career. He raised that journal to its present prosperity. Mr. Hart, though too fully occupied with literary work to be a very active student of any branch of science, cultivated several. Among these, perhaps, that of bacteriology in connection with epidemic diseases most interested him. He spent much time and attention upon the so-called science of hypnotism, and formed one of a commission to investigate its modern teachings. The report was far from favourable and exposed considerable trickery. As an authority on Japanese art, few were more learned or had a finer collection.

CHARLES LUTWIDGE DODGSON.—In the death of the Rev. C. L. Dodgson, the English-speaking peoples have lost a familiar friend, for was he not the "Lewis Carroll" who wrote the classic "Alice in Wonderland" and "The Hunting of the Snark"? As a man of science he was equally known as a mathematician and author of mathematical works.

THOMAS JEFFERY PARKER, F.R.S.—Information of the death of Professor Parker, of Otago, on November 7th, reached this country with the close of last year. Through his absence from England many of the younger of our readers know less of Prof. Thos. Jeffery Parker's work than would have been otherwise the case. A native of London, he was born in 1850. In 1868 he joined the Royal School of Mines as a student. After a short absence from London, while acting as a science master at Bramham College, he became, on the invitation of Professor Huxley, his demonstrator at South Kensington, in 1872. He was also, whilst holding that office, Lecturer on Biology at Bedford College, London, and Examiner in Zoology and Botany to the University of Aberdeen. In 1880 he became Professor of Biology in the University of Otago, New Zealand.

HENRY STACY MARKS, R.A. The band of lovers of field natural history has lost an ardent member in H. Stacy Marks, whose pictures, generally of a humorous character, were so well known. He was chiefly a student of the habits of birds, and might have been often found at the Zoological Gardens, Regent's Park, with pencil and note-book.



CONDUCTED BY FRANK C. DENNETT.

		Rises.		Sets.		Position at Noon.	
		h. m.	h. m.	h. m.	h. m.	R.A.	Dec.
Sun	1 ...	7:40 a.m.	4:48 p.m.	21:1	17° 0' S.		
	11 ...	7:22	5:6	22:41	13° 55'		
	21 ...	7:3	5:25	22:19	10° 20'		
		Rises.		Sets.		Age at Noon.	
		h. m.	h. m.	h. m.	d. h. m.		
Moon	1 ...	11:32 a.m.	8:20 p.m.	4:15 a.m.	10 4 35		
	11 ...	11:20 p.m.	6:24 a.m.	8:30	20 4 35		
	21 ...	6:59 a.m.	0:42 p.m.	6:41 p.m.	0 16 19		

		Semi		R.A.		Dec.	
		Diameter.	h. m.	h. m.	h. m.	h. m.	Dec.
Mercury	1 ...	1 3/4	19:17	21° 48' S.			
	11 ...	1 1/2	20:12	20° 57'			
	21 ...	1 1/2	21:13	18° 1'			
Venus	1 ...	3 1/2 p.m.	2 48	19° 1' S.			
	11 ...	3:12	21:38	15° 30'			
	21 ...	3:21	22:27	11° 16'			
Mars	1 ...	1:46 a.m.	20:12	20° 58' S.			
	11 ...	3:54	12:10	22° 42' S.			
	21 ...	3:10	12:38	2° 30'			
Jupiter	1 ...	3:12	12:38	2° 30'			
	11 ...	2:32	12:36	2° 11'			
	21 ...	2:14	16:39	20° 21' S.			
Saturn	1 ...	6:41	16:5	20° 30'			
	11 ...	7:49 p.m.	5:16	21° 42' N.			
	21 ...	7:49 p.m.	5:16	21° 42' N.			

MOON'S PHASES.

		h. m.		h. m.	
		Full	3rd Qr.	Full	1st Qr.
Full	Feb. 6	6:24 p.m.	3rd Qr. ...	Feb. 14	0:35 a.m.
New	" 20	7:41 p.m.	1st Qr. ...	" 28	11:13 a.m.

In apogee, February 1st, at 8.7 a.m., distant 251,700 miles; and in perigee on 17th, at 7.3 a.m., distant 228,200 miles.

CONJUNCTIONS OF PLANETS WITH THE MOON:

Feb. 10	...	Jupiter	...	10 p.m.	...	planet 7° 9' N.
15	...	Saturn	...	5 a.m.	...	" 5° 30' N.
19	...	Mars*	...	1	...	" 2° 2' S.
19	...	Mercury†	...	11	...	" 3° 19' S.
21	...	Venus*	...	1	...	" 5° 2' S.

\* Below English horizon. † Daylight.

THE SUN still continues to exhibit spots on his disc, showing that it has not yet reached the time of minimum.

MERCURY is a morning star, poorly placed for observation, though rising on the 1st about 1 hour 14 minutes before the sun. At 6 p.m., on 11th, it is in conjunction with, and only 1' north of Mars, but unfortunately below the English horizon.

VENUS is in superior conjunction at 10 p.m. on 15th, and is too close to the sun for observation.

MARS is too far south and too close to the sun for observation.

JUPITER rises about 10 p.m. on 1st, and just after 8 on 28th, so can be well observed a little south of  $\gamma$  Virginis.

SATURN is a morning star in Ophiuchus, about 10° east of  $\beta$  Scorpii, and rising about 4 1/2 hours before the sun in the middle of the month. The minor axis of the rings still exceeds the apparent diameter of the planet.

URANUS rises more than half an hour before Saturn, and may be found a little south east of  $\beta$  Scorpii.

NEPTUNE is still in good position all the evening.

METEORS may be looked for specially on February 3rd, 7th and 10th.

RED STARS IN POSITION DURING FEBRUARY:

		R.A.		Magni-	
		h. m.	Dec.	tude.	
B 211	Cancri	... 8.49	17° 41' N.	6.5	(?) Variable
6	Leonis	... 9.25	10° 17' N.	6	Orange
R	"	... 9.41	12° 2' N.	5.5-11.5	Fiery (312 days)
9	Sextantis	... 9.48	5° 30' N.	7	
18	"	... 10.6	7° 54' S.	6	
-	Argus	... 9.3	25° 20' S.	5	
B.A.C.	2798 Lyncis	8.16	42° 24' N.	6	

PONS-WINNECKE'S COMET has been picked up by Mr. Perrine, of the Lick Observatory, within 2° of its predicted place. When discovered on January 1st, in R.A. 15h. 19m. 42.5s., S. Dec. 3° 58' 34", it was very feebly visible. It is expected to pass its perihelion on March 20th.

COMETS of 1898.—Encke's is due to make its perihelion passage in May, Swift's (1889, IV.) and Wolf's in June, and Tempel's (1867, II.) in September. Their periods are respectively 3.303, 8.534, 6.821 and 6.507 years.

THE LUNAR ECLIPSE.—Our readers may have been puzzled by finding the times given in our last number in error to the extent of no less than fifty minutes, an error into which so great an authority as "The Nautical Almanac" for 1898 had fallen, though the mistake has been corrected in that for 1899. We have no special note to make respecting the eclipse, save that the edge of the shadow just reached the southern wall of Tycho.

MINOR PLANETS.—During 1897 eight more of these tiny bodies were added to the list of those previously recorded, no less than seven being discovered by M. Charlois, of Nice, and one by Herr Villiger, of Munich Observatory.

PARALLAX OF THE SUN.—Since 1888 over twenty observatories in different parts of the world have been engaged, at the suggestion of Dr. Gill, Her Majesty's Astronomer at the Cape, in a series of careful observations of the minor planets, Iris, Victoria and Sappho, for the purpose of re-determining the solar parallax. The result is 8.802", with possible error 0.005". Supposing Clarke's equatorial radius of the earth, 20,926,202 feet, to be correct, this makes our mean distance from the sun to be 92,874,000 miles.

FRIEDRICH AUGUST THEODORE WINNECKE, whose name is associated with the comet mentioned above, passed away, at Bonn, on December 3rd, 1897, aged 62, having been born at Hanover on February 5th, 1835. After being educated at Berlin, Dr. Winnecke assisted Encke, of that city, and Argelander at Bonn. He received an appointment at Pulkova, and spent many years there. In 1868 he took charge of the observatory at Carlsruhe, and in 1872 was nominated as Professor of Astronomy at the newly-founded University of Strasburg. He was chosen Rector in 1882; but his work was over, though he did not retire until 1886, since which time he has been living in retirement at Bonn. He was elected an Associate of the Royal Astronomical Society in 1863. He also received the prize of the Vienna Academy for his cometary discoveries.

THE late Dr. B. A. Gould is to have his memory kept fresh by a sum of 20,000 dollars, given by his daughter, the interest of which is to be employed in the endowment of astronomical research, practical work to be favoured rather than physical.



M. HENRI DE PARVILLE, editor of *La Nature*, has been elected an officer of the French Legion of Honour.

PROF. E. RAY LANKESTER, F.R.S., has been appointed to the Fullerian Professorship of Physiology in the Royal Institution.

THE veteran Dr. Alfred Russel Wallace, F.R.S., is about to publish a work entitled "The Wonderful Century: its Successes and its Failures." The book will be issued by Messrs. Swan, Sonnenschein and Co.

AMONG other deaths is that of M. G. de Layens, the popular French botanist, who wrote, in collaboration with M. G. Bonnier, "The Elementary Flora of France."

THE Scarborough Field Naturalists' Society has issued the first part of "Natural History Records of the Scarborough District." It consists of the Vertebrates, exclusive of fishes.

WE have received from Herr Gebrüder Barntraeger, Berlin, an artistically produced catalogue of scientific works, chiefly botanical. They are in most cases by German authors.

OUR correspondent, Mr. Alfred H. Bastin, of Ivy House, New Road, Reading, desires it to be known that he is able to undertake the setting and mounting of insects. He will furnish particulars and terms on application.

AMONG our monthly budget of second-hand book catalogues, that of Felix Alcan, 108, Boulevard Saint Germain, Paris, will be found useful to those of our readers who require works on social science and general natural history.

OUR contemporary, "The Journal of Conchology," has increased the amount of matter on each page, so that the contents are enlarged by about twenty-five per cent. The last volume contains a more useful index than those hitherto published.

THE ornithological collection of Central Italy in the Zoological Museum at Rome has received from MM. Lepri and Patrizi a gift of several hundred birds from the Roman region, in which there are many rarities. The Museum already has about 1,500 specimens.

MR. R. F. SCHARFF, in the last number of the "Irish Naturalist," has an interesting note upon the discovery of remains of a wild horse, *Equus caballus*, near Naas, co. Kildare, Ireland. The bones have been presented to the Dublin Science and Art Museum by Major Moore.

WE have received an interesting reprint of the presidential address of Mr. J. Cosmo Melvill. It was given before the British Conchological Society, and is extracted from the Society's "Journal of Conchology." The subject is an historical sketch of the principles of nomenclature and their application to recent mollusca, particularly in regard to pre-Linnean authors.

DR. HENRY LAVER has arranged to publish by subscription a work on "The Mammals, Reptiles and Fishes of Essex." It will be under the auspices of the Essex Field Club.

PROFESSOR ERNST LUDWIG TASCHEMBERG, a celebrated entomologist, has died at Halle-an-der-Saale. He was born in 1818, and was best known by his work in economic entomology and the study of Hymenoptera. He was appointed to an office in the Zoological Museum of Halle in 1856.

THERE is to be arranged at Cannstatt, Württemberg, this February, a general and national exhibition of all that concerns calcium carbide, of acetylene gas and of its applications. This will be first special public exhibition of one of the most important lighting powers of the future.

THE Natural History Society of Provence, started two years ago at Aix, under the presidency of M. le Vicomte de Selles, meets bi-monthly. The English winter visitors interested in biology would do well to look up some of the members, as this is one of the most interesting regions in Europe, and includes the French Riviera.

AT the last Entomological Club Meeting held at the Holborn Restaurant, Mr. Verrell, for the ninth year in succession, acted as host for the evening. There was a large attendance of members and visitors. It was announced that, for the first time for many years, the limit of eight members had been reached.

WE are pleased to observe that the Journal of the Board of Agriculture has lately included some articles upon natural-history subjects. In the number for December there are no less than four: "The Mole," by J. E. Harting, F.L.S., "The Barn Owl," "The Red Spider, or Spinning Mite," and "An Orchid Bug" are titles of others.

WE are glad to hear that one of the leading subjects for discussion in the International Zoological Congress at Cambridge in August next, is to be the whole question of the chaotic condition of scientific nomenclature. We sincerely trust that certain acceptable rules may be laid down which will bring to an end the present state of constant change of generic and specific names in many orders.

WE have received a new magazine, entitled the "Home University," the first number of which appeared on January 15th, price one shilling. The object of this magazine is to deal with all subjects, and be suitable for all readers. It is not intended to be a school-book, or encyclopædia, nor a journal of science and literature, but it will partake of the character of all three. In the number before us the subjects are certainly very varied, including history, languages, and some natural history.

THE Academy of Natural Sciences of Philadelphia has received from Mrs. Emma W. Hayden, the sum of \$2,500 in trust, to be known as the Hayden Memorial Geological Fund, and to be in memory of her husband, the late Prof. Ferdinand V. Hayden, M.D., LL.D. A bronze medal and the balance of the interest arising from the Fund are to be given each year for the best publication, exploration, discovery or research in the sciences of geology and palaeontology. The fund is not confined to American naturalists, but is open to strangers.

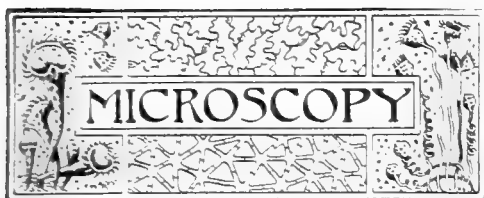

CONDUCTED BY J. H. COOKE, F.L.S., F.G.S.

To whom Notes, Articles and material relating to *Microscopy*, and intended for SCIENCE-GOSSIP, are, in the first instance, to be sent, addressed "J. H. Cooke, Thorndale, Lincoln."

**MICROSCOPICAL PREPARATIONS.**—We are in receipt of a copy of the "Revised Catalogue of Microscopical Slides, etc., 1897," issued by Mr. R. Suter, of South Tottenham, Middlesex. It contains some useful detailed lists of mounting materials and naturalists' requisites.

**A MINUTE FLOWERING PLANT.**—The smallest flowering plant yet discovered is the *Wolffia brasiliensis*, of the Duckweed family, which appears on stagnant pools as a green ball, a thirteenth of an inch in diameter.

**ROSS' INDUSTRIAL MICROSCOPE.**—The great utility of microscopical research to purposes of advanced agriculture is now so fully recognized that the recent demand for a less costly instrument than those usually supplied has induced Messrs. Ross and Co. to design, for the use of farmers, manufacturers in the textile trades, and students, a microscope which, while combining efficiency with stability, is free from any unnecessary complication. Those who may require such an instrument at a most reasonable price, should see Ross' New "Industrial" Microscope.

**MICROSTEREOGRAMS.**—Many methods for the production of microstereograms of microscopic objects have been proposed, all of which are more or less practicable with low-power objectives. Dr. Gebhardt, in "Photographische Rundschau," describes yet another which enables the operator to produce photographic stereograms with high-power objectives. The effects are strikingly stereoscopic, and, as no special appliances are required beyond the ordinary Abbe condenser, anyone possessing a moderately equipped microscope and a camera can try the experiment for himself. Two exposures are made, the lighting being so arranged that the object is first illuminated on one side and afterwards on the other. By this method, something equivalent to an optical shading of half the objective is realized, the result of which is an appearance of solidity in the object that is most striking.

**CRYSTALLIZATION OF SALTS.**—The following method of preparing salt crystals on glass slides for use with the micro-polariscope is simple, practical and effective. Either of the following salts: barium nitrate, potassium chlorate or oxalate, sodium oxalate or nitrate, zinc or copper acetate, microcosmic salt or iron sulphate, may be dissolved in hot water to make saturated solutions; benzoic acid or phthalic acid, being insoluble in water, must be dissolved in alcohol. Having carefully cleaned the glass slide, apply a little of the solution to it and lay it quite flat, covered with a tumbler to prevent dust settling on it. The addition of a little sugar to the solution tends to fix the crystals to the slide, but if it is desired to make lantern slides, the salts should be dissolved in beer instead of water. In this case, the sugar may be dispensed with

**CUTTING SECTIONS OF LIGNITE.**—The intense blackness of lignite is a serious obstacle to a satisfactory microscopical examination. It is most difficult to get a section by the ordinary grinding processes that shall be thin enough to allow of its structure being viewed by transmitted light. Even when the section is so thin as to be on the verge of breaking up, it is still too opaque for the strongest light to pass through it. The best method to adopt is that which is recommended by Griffith and Henfrey for the examination of coal. The specimen should be macerated for a week or more in a strong solution of carbonate of potash, at the end of which time it is possible to cut tolerably thin slices with a razor. These slices are then placed in a watch-glass with strong nitric acid, covered, and gently heated; they soon turn brownish, then yellow, when the process must be arrested by dropping the whole into cold water, or else the specimen would be dissolved. The slices thus treated appear of a darkish amber colour, very transparent, and exhibit the structure, where existing, most clearly. The specimens are then carefully washed in pure water, and are best examined in glycerine, and may be mounted permanently in cells of that fluid.

**HADDONIA.**—This new genus of foraminifera, Mr. F. Chapman explained at a recent meeting of the Linnean Society, is a calcareo-arenaceous type, of the sub-family Lituolinae (of Brady). The species *Haddonia torresiensis* is adherent to coral-rock, and resembles an attached and well-grown Haplophragmium. The aperture is partially closed by a flap or valve, sometimes directed towards, sometimes away from, the attached surface of the test. The specimens of *H. torresiensis* were found in great abundance on two specimens of coral rock collected by Professor A. C. Haddon, in the Torres Straits, in 1889.

**PARASITIC ENEMIES OF THE HOUSE FLY.**—The house fly has a number of natural enemies, many of which serve as interesting subjects for microscopical investigation. In its larval stages it is subject to the attacks of hymenopterous parasites and of predatory beetles. In its adult condition it is infested by a small reddish mite, which frequently covers its body and gradually destroys it. It is also killed in considerable numbers by the common house centipede. Its most effective enemy, however, is a fungus disease known as *Empusina muscae*, which carries it off in great numbers, particularly towards the close of the season. The epidemic ceases in winter, and although enormous numbers are killed by it, the remarkable rapidity of development in the early summer months more than replaces the thousands thus destroyed.

**MOUNTING FORAMINIFERA.**—Mr. E. Earland recommends gum tragacanth as being the best fixative medium for mounting foraminifera. It is preferable to gum arabic as it becomes nearly invisible when dry, and it is also less subject to the influence of those changes in the weather which often cause foraminifera mounted with gum arabic to crack and break. Mr. Earland prepares his mountant by partially dissolving the finest powdered gum tragacanth in spirits of wine just sufficient to cover the powder. A small crystal of thymol added to the spirit sterilizes and preserves the mucilage from mould, after which sufficient distilled water is added to dilute it, till it becomes a very thin jelly of such a consistency that will not run from the bottle when tilted. The gum

contracts and disappears in drying, so that there is no need to use it too sparingly in mounting. For mounting foraminifera in balsam, a little of the same gum may be diluted with distilled water, until it forms a perfectly clear liquid. A drop of this on the glass slip will be sufficiently strong to hold the foraminifera in position; and at the same time will not show, provided the mount is thoroughly dried before the balsam is added.

**A CURIOUS SWIMMING FERN.**—At a recent meeting of the Leeuwenhoek Microscopical Club, Manchester, Mr. C. Bailey described the life-history and structure of a curious swimming fern, *Salvinia natans*, Willd. This plant is allied to the pillwort, *Pilularia globulifera*, Linn., and it is distinguishable from the true ferns by its possessing two different kinds of spores, one kind being very much larger than the other. It occurs in abundance on the Continent, especially on the neighbouring coasts of Belgium and France, but it has not yet been found anywhere in the British Isles. The plant passes the whole of its life in fresh water. In its adult state it floats on the surface with its green fronds or leaves. Depending from the undersides of its stem are long submerged leaves which take upon themselves the form and functions of roots (fig. 1). Its spores are contained in little globular capsules, or spheres, termed sporocarps, found at the base of the fronds and close to the stem. These sporocarps help to sustain the floating plant by means of the air canals which run within the external ridges of the capsule (figs. 2 and 3). The spores are disseminated first by the sporocarps breaking off from their stalks at their points of junction with the leaves. These in their turn float by means of a coating formed of hardened mucilage mixed with minute bubbles of air. In the early spring germination ensues, thus completing the life-cycle. The main features of the minute anatomy of the organs are shown in the following figures. Fig. 4 represents a section across a group of three sporocarps, one with macrosporangia (ma) and two with microsporangia (mi). Fig. 5 shows a ripe microsporangia,  $\times 300$ , with the tubes of the microspores (t) breaking through.

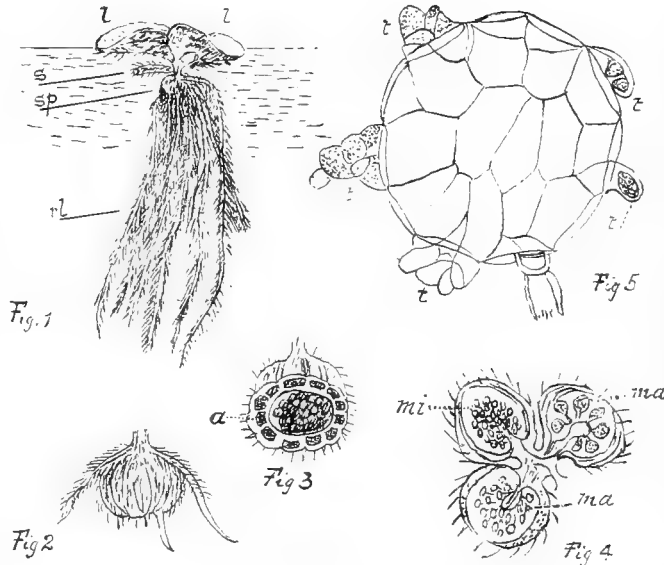

SWIMMING FERN.

Fig. 1. The whole plant with its floating fronds and submerged roots. Fig. 2. A sporocarp at the base of a frond. Fig. 3. A cross-section of a sporocarp showing air canals. Fig. 4. A section across three sporocarps, one with macrosporangia (ma) and two with microsporangia (mi). Fig. 5. A ripe microsporangium showing tubes of microspores (t) breaking through.

**THE QUEKETT MICROSCOPICAL CLUB.**—The last journal of proceedings of this society contains "Infection of Ducks," by J. B. Rosseter; "Foraminifera," by A. Earland; a note on the "Male of *Proales wernkei*," by C. F. Roussellet; "Logarithmic

Plotting of Data," by D. C. Scourfield; an account of "*Peripatus moseleyi*," by the Rev. J. R. Ward; and numerous interesting notes on "Diatom Structure," "Mycetozoa" and "Double Colour Illumination." Mr. A. Earland's very practical paper, on "The Best Methods of Collecting and Preparing Foraminiferous Materials," is full of hints and suggestions, and it will well repay perusal. In "A Short Note on Minute Diatom Structure," Mr. E. M. Nelson reports two further results in the resolution of fine diatomic structures. The first is the detection of the long-shaped aperture in the nodule of *Navicula rhomboides*; the second relates to a diatom *Biddulphia elabovata* mounted in styrax, in which a delicately perforated membrane, not hitherto discovered, has now been made out with the assistance of the new Powell apochromatic adjustable condenser. Oblique illumination completely obliterates this structure, which can only be seen by means of a direct axial cone of maximum dry aperture. We note also that at a recent

meeting of this club Mr. G. Masee gave an address, "On the Evolution of the Basidiomycetes," illustrated by a series of coloured drawings and blackboard sketches. He described the fructification of this class of fungi and the various means taken by the different families for distributing the basidiospores. At the same meeting Mr. Goodwin briefly described his method of increasing the size of the image of the lamp flame by placing a

weak convex lens under the lower combination of the condenser.

**THE MICRO-STRUCTURE OF ALLOYS.**—At a recent *Conversazione* of the Royal Society, a series of photographs were shown demonstrating that when fluid mixtures of metals and non-metals are allowed to cool, crystals of definite chemical composition are formed. They may be clearly seen with the aid of a microscope after the polished surfaces have been etched with dilute acids, or tinted with suitable re-agents.

**THE FIG SCALE.**—In the land areas in and around the Mediterranean, scale insects are numbered among the most destructive pests that the orange and fig growers have to contend with. Of these *Coccus rusci*, the parasite of the fig, is just now attracting much attention in Italy. The diameter of a well-developed female is five millimetres, the colour is greyish-white, and they have the appearance of small cones upon the trunk and boughs of

the tree. They cover themselves with a substance like wax, which effectually protects them from insecticides. If this and the skin be carefully removed, a vast number of eggs of a reddish-brown colour will be observed lying beneath. These rapidly change to larvæ, and in a few days nourish themselves. At this stage they undergo a strange metamorphosis: their legs drop off, their eyes disappear, and their bodies exude the waxy secretion which ultimately serves as a protective covering. Ample material for study is afforded English microscopists on the imported oranges and figs

There were found within the pollen-tube, near its basal end, two cells, one in front of the other.

Each of the cells thus formed develops into a motile antherozoid, two being formed in each pollen tube. They are surrounded by a spirally-arranged band of cilia, developed from a centrosome-like body within the cell. The mature antherozoids pass into the secondary embryo-sac through an orifice in the extremity of the pollen-tube, the watery contents of the pollen-tube furnishing the necessary water for their locomotion. These objects will repay investigation.

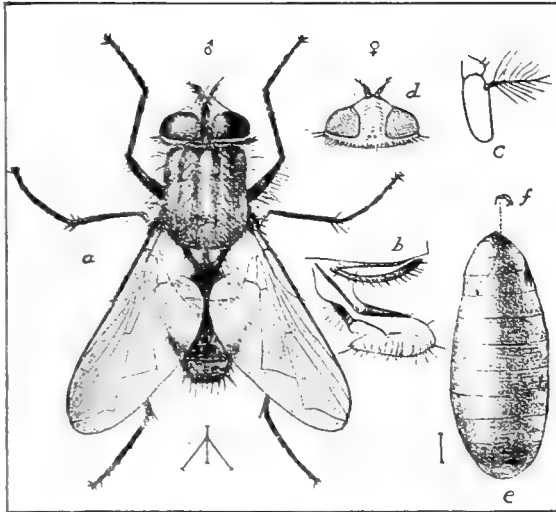

THE HOUSE FLY (*Musca domestica*.)

a, Adult male; b, proboscis and palpus of same; c, terminal joints of antennæ; d, head of female; e, puparium f, anterior spiracle—all enlarged (original).

**THE HOUSE FLY.**—The number

of eggs laid by an individual house fly, *Musca domestica*, in one season is estimated to average about 120, and as, from experiments conducted by Professor Howard and Mr. D. W. Coquillett, it was shown that the total life round from the deposition of the egg to the death of the adult is approximately ten days, the enormous numbers in which this insect occurs is plainly accounted for. The experiments showed that horse manure is the favourite breeding place of the *Musca domestica*, and continuous observations indicated that the larvæ moult twice, and there are thus three distinct larval stages. How very interesting the life cycle of this common pest is has been well shown in a paper contributed to "Insect Life" by Messrs L. O. Howard and C. L. Marlatt. The different stages of the insect are well illustrated in the accompanying figures, and need no description.

ning of sweet corn is an industry of remarkable growth, the first corn having been packed about

1853, while 72,000 tons were put up in the United States in 1895. Recent large losses from souring have led to an investigation at the Massachusetts Institute of Technology. The souring is found to be due to fermentation set up by bacteria which exist on the corn in the field, and are not destroyed by the temperature of 180° to 190°, at which the corn is corked in the cans. To effect sterilization the packer places the cans in retorts heated by steam under pressure. Experiment has shown that a temperature above the boiling-point of water must be reached throughout the corn to kill all bacteria, and that exposure of the cans for sixty minutes to 250 Fah. ensures complete sterilization, but the minimum time and temperature of safety are still to be determined.

**BACTERIA OF CORN.**—The can-

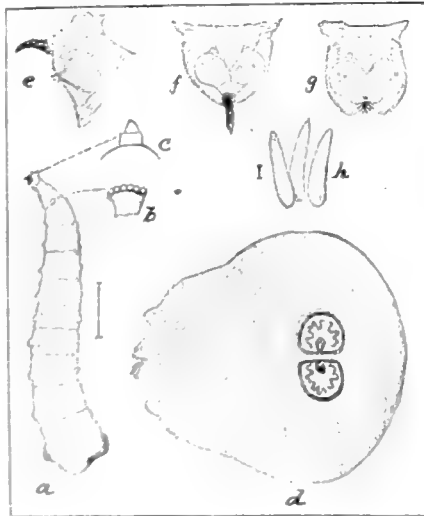

THE HOUSE FLY (*Musca domestica*.)

a, Full-grown larva; b, one of its anterior spiracles; c, side view of head; d, hind end of body showing anal spiracles; e, side view of head; f, head from above; g, head of young larva from above; h, eggs—all enlarged (original).

**ANTHEROZOIDS OF ZAMIA**—The "Botanical Gazette" records the discovery by Mr. H. G. Webber of motile antherozoids in *Zamia integrifolia*

**EPRATUM.**—In the December issue, fifteenth paragraph, for "pliocene" diatomaceae read "eocene."



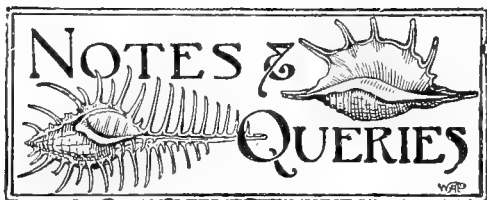

**THE MILD WINTER.**—During a visit to Margate, East Kent, last Christmas, I observed, on December 26th, both *Helix cantiana* and *H. virgata* actively crawling about on dead grass stems in the warm sunlight.—*Thomas Edwards, Cliftonville House, Leicester.*

**DR. WILLIAM HARVEY.**—For the honour of my old school, I must correct your statement that the great Dr. William Harvey was educated at Folkestone. He was one of the sons of the King's School, Canterbury.—(*Rev.*) *J. W. Horsley, St. Peter's Rectory, Watworth, S.E.*

**DOUBLE MUSHROOM.**—The figure on this page represents a sketch of a remarkable mushroom sent to us by Mr. G. O. Silverlock, of 97, George Street, Croydon, who found it among others which had been grown for food. It represents a "double" specimen, each complete in gills, the upper one inverted on the lower. There is no indication of a joint where the pileus or cap of each meets, and when received, the two sets of hymenium or gill surface were perfectly healthy, and each set had deposited spores on the white cotton-wool used in packing. In place of a stem, the upper part only indicates where it had been, by small atrophied remains, as shown in the sketch. The outer skin of the two caps is perfect. When fresh this curious specimen was quite symmetrical, the upper portion being smaller than the lower. We have dried it, and though much less in size, it still shows its abnormal characters very plainly.—*John T. Carrington.*

**YUCCA FLOWERING IN WINTER.**—In a garden with south aspect, a few doors from the chief post-office at Southend-on-Sea, a plant of some species of *Yucca* had, throughout this January, a large truss of bloom and buds numbering upwards of a hundred. This is a most unusual time for these plants to flower in the open in Britain.—*J. T. C.*

**RAGGED-ROBIN IN WINTER.**—During the second week in January this year, while travelling along the coach road from Lynton to Barnstaple, in North Devonshire, I observed *Lychnis flos-cuculi* (ragged-robin) in flower. The bloom was bright in colour, about the usual size, and apparently from a seedling of one of last year's plants.—*C. A. Briggs, Rock House, Lynmouth.*

**NATURAL HISTORY SOCIETIES AND TECHNICAL INSTITUTES.**—At the Congress of the South-Eastern Union of Scientific Societies held last May at Tunbridge Wells, attention was drawn by Mr. S. Atwood to the occasional difficulty of securing rooms for meetings of scientific societies, even when payment is offered and suitable rooms belonging to Technical Instruction Committees are actually unoccupied. This was considered to be so unsatisfactory and opposed to the growth of culture, that the Council of the Union was requested to take whatever steps it might consider necessary to remove such an obvious grievance. As the result of a correspondence with the Secretary of the Technical Education Committee of the Kent County Council, I am pleased to state that in future there will be no obstacle to the use of such rooms in that county. The local committees of Technical Institutes have now the liberty and power to sublet their premises to the committees of our local natural history societies. This, of course, is nothing less than what we have a right to expect, though hitherto such rooms have not been available for the purpose.—*George Abbott, M.R.C.S., Hon. Sec. South-Eastern Union of Scientific Societies, Tunbridge Wells.*



"DOUBLE" MUSHROOM.

**NEWSPAPER NATURAL HISTORY.**—The following makes an amusing addition for those who collect instances of newspaper science. It is taken from the "Cambridge News," of January 10th, 1898. It is needless to comment further than to wonder how such a communication could be passed for press in a modern newspaper in these days of free education. We should think that members of the infant classes in a Board School could tell the writer of the following letter that butterflies do not possess jaws with which to feed upon Brussels sprouts, to say nothing of his statement that a yellow butterfly had changed its colour to a pale green in consequence of devouring that succulent pabulum. Such

a remark is about equal to the ignorance of the fact that a number of different kinds of British butterflies pass the winter as perfect insects.

"Can any of your correspondents tell me if it is not a record to have a live butterfly at this time of the year? as I have one that was yellow when I first caught it a week before Christmas, but through feeding it on Brussels sprouts it has got to a pale green. It is still alive in my possession.—I remain, yours truly, *J. MARSHALL, 21, Prospect Row, January 10th, 1898.*"

Such an effusion is well worthy of the latter-day newspaper "scientist."

**HONEYCOMB WEATHERING ON STONE.**—Would some of your readers kindly assist me in elucidating the cause of honeycomb weathering on surfaces of buildings or sandstone rocks, either by the loan of photographs, which I should be willing to purchase if good ones, or by reference to papers?—*Geo. Abbott, M.R.C.S.*



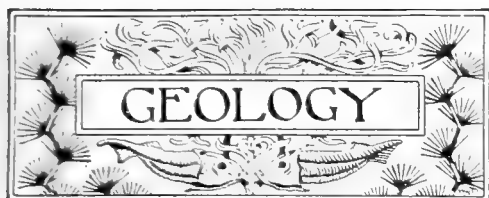

CONDUCTED BY EDWARD A. MARTIN, F.G.S.

To whom all Notes, Articles and material relating to *Geology*, and intended for *SCIENCE-GOSSIP*, are, in the first instance, to be addressed at 69, Bensham Manor Road, Thornton Heath.

**FOREIGN STONES IN CHALK.**—With reference to the question of pebbles and boulders in the chalk, Mr. A. E. Salter, F.G.S., pointed out before the Geological Society that smaller pebbles are fairly numerous. The same pit from whence came the Purley Boulder has yielded recently at least a dozen specimens of various rocks, whilst others have been obtained from Burham and Northfleet. Fossil collectors might do well to search for similar specimens. I shall be glad to hear from any reader who has happened upon foreign stones of any kind in the chalk.

**AGE OF THE EARTH.**—Geologists are as interested as ever in the great question of the world's age. Are we to accept, as did Prof. Huxley, the dictum of the physicists, that we must include the formation of all our stratified deposits without the last 100,000,000 years? There is apparently no help but to do so. If so, it is interesting to bear in mind the dates that have been assigned to various formations by Dr. Croll in his "Climate and Time." It is a quarter of a century since that epoch-making book was published. Perhaps some notes showing the conclusions to which he came, may be useful to the younger geologists.

**RATE OF DENUDATION.**—Dr. Croll, after careful consideration, estimated that the rate at which the general surface of the globe is being lowered by sub-aerial denudation could not be much less than one foot in 6,000 years. He considered that what is known as the Glacial Period coincided with a period of great eccentricity of the earth's orbit, which came to a close about 80,000 years ago. Since that date, the surface of the earth at the above rate of denudation would have been lowered on the average by 13 feet. This total is, however, not sufficient to remove the superficial glacial accumulations, such as Kames and Eskers, gravel mounds, knolls of boulder clay, etc.

**ANCIENT GLACIATION.**—Two other periods of great eccentricity terminated about 720,000 and 2,450,000 years ago respectively; but traces of glaciation which occurred, without doubt, according to Dr. Croll, at those times, would have been almost completely removed in the meantime. They may, however, have produced glacial periods in Miocene and Eocene times respectively.

**EVIDENCE OF GLACIATION.**—The greatest differences of opinion are held nowadays as to what constitutes undoubted evidence of the glaciation of a country's surface. Even the manner of formation of boulder clay is not thoroughly understood. If caused by land-ice, the thought at once arises that if there had been no land where now the boulder clay is found, possibly no deposit might have been laid down at all, and no evidence furnished of the glaciation for future geologists. In such a case, the boulders to which we referred

last month as having been found in the chalk, may be sufficient evidence of a veritable glacial epoch occurring even in Cretaceous times. They may show its principal effects on lands which have since suffered extreme denudation, or which are now still beneath the sea. Here, too, would be a satisfactory explanation of those puzzling bands of clayey-chalk which occur at all levels in the true chalk, and to explain which it is impossible to believe in repeated temporary shallowing of the sea-bottom. Icebergs from the nearest coast might well be the bearers of fine clay frozen in its mass.

**GEOLOGICAL DATES.**—Our leading geologists are seldom disposed nowadays to hazard certain dates as those in which our principal formations were laid down. Geologists of a past generation were perhaps more speculative than we are. Sir Chas. Lyell suggested dates in the world's history which placed the earliest sedimentary formations far beyond the limit allowed by our present physical authority, Lord Kelvin.

**AGE OF PRE-CAMBRIAN SERIES.**—Dr. Croll suggested that the Cambrian rocks may be but sixty millions of years old. This estimate thus leaves a great length of pre-Cambrian time in which to allow of the evolution of life from probable lowly-organized primitive forms to the varied fauna of Cambrian age. Professor Ramsay has said that in the life of the Cambrian age "we find no evidence of its having lived near the beginning of the zoological series. In a broad sense, all the phenomena connected with this old period seem to my mind to be of a quite recent description, and the climates of seas and lands were of the very same kind as those that the world enjoys at the present day."

**VARYING DISTANCE OF SUN.**—The mean distance of the sun is now 91,400,000 miles. Its present distance in mid-winter is 89,864,480 miles. At Croll's suggested Miocene glacial epoch, 850,000 years ago, when the winter solstice was in perihelion, his distance in mid-winter would be no less than 98,224,289 miles. "Our winters are now shorter by 78 days than summers, but at that period they would be longer than the summers by 347 days. . . . At present the difference between perihelion and aphelion distance of the sun amounts to only 3,069,580 miles; but at the period under consideration it would amount to no less than 13,648,579 miles."

**INTENSITY OF GLACIAL PERIOD.**—Dr. Croll says: "The more severe a glacial epoch is, the more marked ought to be the character of its warm inter-glacial periods. The greater the extension of the ice during the cold periods of a glacial epoch the further should that ice disappear in arctic regions during the corresponding warm periods. . . . Judged by this test, we have every reason to believe that the Miocene glacial epoch was one of extreme severity. . . . The Eocene period extends from about 2,620,000 to about 2,460,000 years ago; and the Miocene period lasted from about 980,000 to about 720,000 years ago."

**CAUSE OF ANCIENT SUBMERGENCE.**—Submergence to as much as a thousand feet during the glacial epoch, explained by the transference of the ice-cap from south to north pole, the consequent northerly shifting of earth's centre of gravity, and the efforts of the ocean to adjust itself as a sphere around that centre of gravity. On this supposition submergence is the result, not of subsidence of the land, but of a movement of the waters of the ocean towards the north.



CONTRIBUTED BY FLORA WINSTONE.

LA FEUILLE DES JEUNES NATURALISTES (Paris, January, 1898). The editor announces that on February 1st an important addition will be made to the library, open to readers of the paper, in the form of eight natural history collections, including Tortrices, Coleoptera, shells and mosses, lent by various gentlemen, who have, in most instances, personally collected the specimens. Amongst them there are fine collections of *Pomatias* from all parts of Europe, made by Messrs. Dautzenberg, Standinger, Margier, Caziot, Langlissé and Dollfus. The exhibition will be open for one month. The object of M. Dollfus is to give his readers an opportunity of studying the decisions and practical work of specialists with whose publications they are already familiar. Our readers who may be visiting Paris will doubtless also be welcome to examine these collections, which are deposited at 35, Rue Pierre-Charron. M. Ernest Andree commences a "Synopsis of the Mutillides of France." His descriptions are arranged in a tabular form, and in this number include the following genera: *Methoca*, *Myrmosa*, and an analysis of characters of males and females. M. Gustav F. Dollfus continues his discussion upon the "Formation of the Chloritic Marl Stratum." He states that M. J. Lambert, having examined the Echinides of the fauna, is of opinion that they are closely allied to those of the Cenomanian stage. M. Eugene Simon contributes some further notes on the "Revision of the Trochilidés," dealing this time with the genera *Aglæactis*, *Boissonneauxia*, *Engyete* and *Spathura*. M. Henry W. Broelemann supplies some facts towards a description of one of the fauna of the Myriapodes of France, *Geophilus pinguis*, n. sp. Among the notes is one by M. Pierre Marty, giving a catalogue of the birds of Cantal which, he says, have not yet been described.

THE VICTORIAN NATURALIST (Melbourne, December, 1897). M. C. French contributes some interesting notes on a "Trip to Brisbane." Mr. Oswald B. Lower, F.E.S., continues a "Catalogue of Victorian Heterocera," this being Part xxvi. The families included in this number are Elachistidae (concluded), Plutellidae and Tineidae; one of the genus *Limnoecia* (*L. phragmitella*) and one of *Endrosia* (*E. lacteella*) are introduced species. (September, 1897.) This number contains the preliminary notice of the seventh session of the Australasian Association for Advancement of Science. Mr. T. S. Hall contributes an account of a geological excursion to Collingwood Quarries, and Mr. Robert Hall gives some notes on the "Bird Fauna of the Box Hill District"; Mr. J. A. Kershaw writes on the Synonymy of *Pievis perinale*, Don. It is, he says, generally known as *Pievis scyllava*, but its long list of synonyms shows the confusion that has been created by the variability of this species. This number contains Part xxv. of Mr. Oswald B. Lower's "Catalogue of Victorian Heterocera," the families included being Gelechiidae and Elachistidae.



ROYAL METEOROLOGICAL SOCIETY.—The annual meeting of this Society was held on Wednesday, January 19th, at the Institution of Civil Engineers, Mr. E. Mawley, F.R.H.S., President, in the chair. The Secretary read the report of the Council for the year 1897, showing that there had been an increase in the number of Fellows, and that the finances were satisfactory. The President, Mr. Edward Mawley, then gave an address on "Weather Influences on Farm and Garden Crops," in which he pointed out the intimate connection between meteorology, agriculture and horticulture. He explained the special characteristics of the climate of the British Isles as regards temperature, rainfall, etc. Of all the influences brought to bear on vegetable life by the atmosphere, he considered temperature to be the most powerful and far-reaching, and only second to this came rainfall. The leading effects of snow, wind, and sunshine, as well as of prolonged droughts, severe frosts and persistent rains, were also described. He then dealt with the influence of different important weather changes on such farm crops as wheat, roots, grass, etc., as well as on fruit trees, vegetables and flowering plants in the garden. In his concluding remarks he called attention to the great want of experimental farms, in conjunction with meteorological stations, being established in this and other countries in Europe, for it was only by the examination of meteorological observations, together with weekly records of the extent and character of the growth made by our leading crops, that the close connection existing between weather changes and their influences on such crops could be clearly traced. Mr. F. C. Bayard, LL.M., was elected President for the year.

NORTH LONDON NATURAL HISTORY SOCIETY.—Thursday, December 2nd, 1897.—Mr. C. Nicholson, F.E.S., President, in the chair. Exhibits: Mr. Bacot, hybrids between *Tephrosia bistortata* and *T. crepuscularia*; ditto between *T. bistortata* and var. *delameyensis*; second crosses between different pairings of the hybrid moths; crosses between the second brood of hybrid moths and a second brood of *T. crepuscularia*. Also specimens of second broods of *T. bistortata* and *T. crepuscularia*. Mr. E. M. Dadd, specimens of *Catocala nupta*, *C. elegata* and *C. fraxini*, on which he read some interesting notes. Mr. Jennings, a living example of the so-called Roman snail (*Helix pomatia*), taken in Headley Lane, Surrey, on September 4th last. Also a series of the yellow variety *lutea* of *H. hortensis*, all taken in the Lea Valley, in 1893-4. He stated that both type and variety were common, although it was not always easy to get the shells in good condition. Mr. Battley recorded the following observations on a blackbird's nest at Stamford Hill: "1897, April 10, began sitting—four eggs; April 23rd, eggs hatched; May 6th, birds flew; May 17, began sitting—four eggs, nest not repaired; May 29th, eggs hatched; June 8th (?), birds flew; June 12th, nest repaired; June 19th, began sitting—four eggs; July 4th, two eggs hatched, others added; July 17th, birds flew. Three broods in fourteen

weeks Mr. Simes read an interesting paper, called, "Through Devon and Cornwall." It was generally descriptive, but contained many natural-history notes of interest. He had for the first time noticed the wall-flower justifying its name by growing over a red brick viaduct near Liskeard. He had noticed numerous meadow pipits in the fields on leaving Penzance, and remarked that this bird enjoyed the proud distinction of being the victim of the cuckoo more frequently than any other. He also said that the Cornishmen turn furze to account in many ways: cattle feed on it freely. It makes good fuel when dried. The flowers are an Eldorado for hive-bees, and the tender green shoots are cooked and served in place of cabbage. Remarking on the natural features of Cornwall, he said that the face of this extreme portion of the western peninsula can have changed but little since the days of Merlin. The actual coast, granite bound, must be nearly the same as when the first Greek or Phœnician trader landed. It cannot have receded like the soft sandstone shores of south Devon, or the flat lands of the eastern coasts. Two or three miles north of Newquay he had seen a pair of ravens sitting on the edge of the cliff, and he referred to the rapidity with which the raven discerns the carcase of any dead animal. Not much in the way of lepidoptera had been seen, the rarest species met with being a full-fed larvae of *Lasiocampa quercifolia*, unfortunately injured, near Boscastle. He also gave a list of the wildflowers in the hedgerows there which were in blossom on May 19th. The roadside banks were in places perfectly blue with the germander and other speedwells. He had passed the collecting-ground for the largest of the British blue butterflies (*Lycæna arion*), and did not believe that over-collecting could do the insect any damage there. Noticing the swallows near Bideford, he remarked how all this tribe seemed to take great delight in dipping their breasts in the stream as they skim over its surface, and when they have performed the operation about a dozen times, they sit on the telegraph wires in the sun, and preen their feathers. Immediately, however, they have got dry, they fly back to the pool and start bathing afresh. Mr. Culpin doubted that the raven and its kind found their carrion food by smell. On one occasion, when fishing in Queensland, he had left his fish tied up in the water. Coming back he found that three kites had killed the whole. These fish were in the water, and probably smelt no differently because they were tied up. He gave another instance of birds having detected meat, even though wrapped up in tarpaulin. His opinion was that they found their food not only by scent but by sight also. Mr. W. H. Barber was of the same opinion, and gave an instance of his having been shooting up the River Busi in Mozambique. A buck had just been shot, and the vultures immediately came to the spot, though none had been seen for two months previously—*Laurence J. Tremayne, Hon. Sec.*

**NOTICE TO SECRETARIES OF SOCIETIES**—We are always pleased to insert abstracts of the Proceedings of societies, so long as they are of general interest. Some secretaries, who kindly send them for publication, would save themselves and the editor much trouble if they would bear that fact in mind. Votes of thanks, election of members, and the usual routine business are of local consequence only. We venture also to ask the reporting secretaries to keep their reports up to date.

## NOTICES OF SOCIETIES.

- GEOLOGISTS' ASSOCIATION OF LONDON.**  
Feb. 4.—The Annual General Meeting, at University College, Gower Street. Presidential Address "Palæolithic Man." 7.30 p.m.
- NORTH LONDON NATURAL HISTORY SOCIETY.**  
Feb. 3.—"Rainfall in India." Stephen Horsley, M.I.C.E.  
" 12.—Visit to the Horniman Museum, Forest Hill, conducted by R. Quick.  
" 17.—"London Clay." J. E. Greenhill, F.G.S.  
Mar. 17.—"Insectivorous Plants." R. W. Robbins.  
" 19.—Visit to the Bethnal Green Museum.  
April 16.—Visit to Kew Gardens.  
" 21.—"Lepidopterous Larvæ." A. Bacot.  
May 5.—Discussion: "Nebulae." Opened by C. Nicholson, F.E.S.  
" 21.—Half-day Excursion to Epping Forest.  
" 27-30.—Excursion to the New Forest—leader, L. J. Tremayne.  
" 30.—Alternative whole-day Excursion to Shere.  
June 16.—"The Catocalidae." E. M. Dadd  
" 18.—Whole-day Excursion to Deal—leader, L. J. Tremayne.  
Visitors will be cordially welcomed at all meetings and excursions. *Laurence J. Tremayne, Hon. Sec.*
- SELBOURNE SOCIETY—CROYDON AND NORWOOD BRANCH.**  
Feb. 5.—"Health and Fashion." E. J. Davies, Lantern Slides. Thornton Heath Polytechnic. 8 p.m.  
April 7.—Social Evening. Exhibits, etc., will be welcomed. Rev. F. E. J. Bird, *Vice-President*, will speak. Seneca Hall, 8 p.m.  
" 21.—Annual Meeting, at Public Hall, Croydon. Subject: "The New Forest." Rev. H. E. H. Bull, M.A. Lantern slides. 8 p.m.
- NORTH KENT NATURAL HISTORY AND SCIENTIFIC SOCIETY.**  
Feb. 9.—"Leaves: their Structure and Use." J. W. Cooper.  
" 23.—"Aquaria and Uncommon Pets." Jno. Potter.  
Mar. 9.—"Conchology." E. Dennis.  
" 23.—"British Birds' Eggs and Nests." D. Miller.  
April 6.—"Lepidoptera." S. J. B. Pine.
- CARLISLE ENTOMOLOGICAL AND NATURAL HISTORY SOCIETY.**  
Feb. 7.—"Coleoptera." F. H. Day.  
" 21.—"Prehistoric Man." J. Murray.  
Mar. 7.—"Lepidoptera taken at light in Carlisle." J. E. Thwaytes.  
" 21.—"Observations on Bird life." B. Johnston. *F. H. Day, Hon. Sec., 6, Currock Terrace, Carlisle.*
- HULL SCIENTIFIC AND FIELD NATURALISTS' CLUB.**  
Feb. 2.—"Breeding-Haunts of British Birds," lantern views. T. Audas, L.D.S.  
" 16.—"An Early Doctrine of Evolution." Rev. C. A. Hall.  
Mar. 2.—"The Natural History of Goole Moor." Thos. Bunker.  
" 16.—"Spectroscopic Astronomy," lantern illustrations. Rev. H. P. Slade, M.B.A.A.  
" 30.—"The Marine Fauna of the Yorkshire Coast," lantern views. F. W. Fierke, M.C.S.  
The Meetings held at 72, Prospect Street, alternate Wednesdays, 8 p.m.—*T. Sheppard, Hon. Sec., 78, Sherburn Street, Hull.*
- PRESTON SCIENTIFIC SOCIETY.**  
April 6.—"Methods of Fishing and Fish Culture on our Coasts." R. L. Ascroft (Member of the Lancashire Sea Fisheries Committee).  
" 20.—"Biography of a Fern." W. Clitheroe. Illustrated by oxy-hydrogen lantern.  
Lecture Hall, Cross Street, Winckley Square, 8 p.m.  
*W. Hy. Heathcote, F.L.S., Secretary, 47, Frenchwood Street.*
- SCARBOROUGH FIELD NATURALISTS' SOCIETY.**  
Feb. 10.—"Birds' Nesting with a Camera." W. J. Clarke.  
" 24.—"A Winter Trip to the West Indies and Venezuela." F. H. Rowntree.  
Mar. 10.—"A Ramble in Kent." J. H. Burton.  
" 24.—Exhibition of Specimens and Discussion.  
April 7.—"A Chat on Shells." R. H. Barker.  
" 21.—Short Papers. Members.  
May 5.—"Anemones." J. C. Harrison.  
" 16.—Y.N.U. Excursion to Clapham for Bowland, Notts.  
" 19.—"An Ardent Entomologist." T. W. Lowsbrough.  
" 30.—Y.N.U. Excursion to Doncaster for Balham and Sandal.  
June 2.—"Chara and Nitella: their structure, life and beauty." D. W. Bevan  
" 16.—"Stems." Miss Major.  
" 18.—Y.N.U. Excursion to Hovingham and Wiggan-thorpe.  
" 30.—Marine Conversation.  
Meetings held in the Museum at 8.15 p.m.  
*Hon. Secs., E. R. Cross and H. Herbert, 75, Prospect Road.*

- TUNBRIDGE WELLS NATURAL HISTORY SOCIETY.  
 Feb. 11.—Specimen and Microscopical Meeting. Short Paper, "An Oak Tree Problem." R. Russell Hutchinson.  
 " 25.—"Kakatoa, the great Volcano." Sir Robert Ball, F.R.S., LL.D.  
 " 26.—"A Universe in motion." Sir Robert Ball, at 3 p.m.  
 Mar. 11.—"Torpedo Warfare." Fleet Engineer T. J. Haddy, R.N.  
 " 25.—"Honeycombing and other forms of weathering of stone." Illustrated by lantern. Geo. Abbott, M.R.C.S.  
 April 8.—"Problems in Plant Life." Benj. Lomax, F.L.S.  
 May 6.—Annual Meeting.  
 Ordinary Meetings in the Literary Society's Library, 32, Pantiles, on Friday evenings at 8.—*Miss Cooke, Hon. Sec., 19, Guildford Road.*
- WARRINGTON FIELD CLUB.  
 Feb. 4.—Short Papers: "Algæ," Rev. H. Brierley. "Physiology of Respiration," lecture, Dr. Bowden.  
 " 18.—"Plant Structure: the Stem and the Flower." A. T. Gillanders.  
 March 4.—"Frog Spawn." L. Greening, F.L.S., M.R.I.A.  
 " 18.—Entomological Evening and Annual Meeting. 7.30 p.m., in the Museum Lecture Room.  
*Alf. J. Jolley, Hon. Sec.*

## METROPOLITAN SCIENTIFIC SOCIETIES.

The following is a list of societies in the London district devoted to natural science, with hours and places of meeting. They may be visited with introduction from a Fellow, Member, or Secretary. Will secretaries send additions or corrections.

- ANTHROPOLOGICAL INSTITUTE OF GREAT BRITAIN, 3, Hanover Square. Second and fourth Tuesdays at 8.30 p.m., November to June.  
 CITY OF LONDON COLLEGE SCIENCE SOCIETY, White Street, Moorfields, E.C. Last Wednesday in each month, October to May, 7.30 p.m.  
 CITY OF LONDON ENTOMOLOGICAL AND NATURAL HISTORY SOCIETY, London Institution, Finsbury Circus. First and third Tuesdays, 7.30 p.m.  
 CONCHOLOGICAL SOCIETY, LONDON BRANCH, St. Peter's Rectory, Walworth. Irregular meetings. Rev. J. W. Horsley, President, will answer enquiries.  
 CROYDON MICROSCOPICAL AND NATURAL HISTORY CLUB, Public Hall. Third Tuesdays, October to May, 8 p.m.  
 DULWICH SCIENTIFIC AND LITERARY ASSOCIATION. Fortnightly lectures Lordship Lane Hall, second and fourth Mondays, 8.15 p.m., from October, for winter season.  
 EALING NATURAL SCIENCE AND MICROSCOPICAL SOCIETY, Victoria Hall, Ealing. Second and last Saturdays, October to May, 8 p.m.  
 ENTOMOLOGICAL SOCIETY, II, Chandos Street, Cavendish Square. First Wednesday, October to June (except January). Third Wednesday, January, February, March and November, 8 p.m.  
 GEOLOGISTS' ASSOCIATION, University College, Gower Street. First Friday, 8 p.m., November to July.  
 GEOLOGICAL SOCIETY OF LONDON, Burlington House, Piccadilly. First and third Wednesdays, 8 p.m., November to June.  
 LAMBETH FIELD CLUB AND SCIENTIFIC SOCIETY, St. Mary Newington Schools, Newington Butts, S.E. First Mondays all the year and third Mondays in winter, 8 p.m.  
 LINNEAN SOCIETY OF LONDON, Burlington House, Piccadilly. First and third Thursdays at 8 p.m., November to June.  
 LONDON AMATEUR SCIENTIFIC SOCIETY, Memorial Hall, Farringdon Street, E.C. Fourth Friday in each month, October to May, 7.30 p.m.  
 LUBBOCK FIELD CLUB. Working Men's College, Great Ormond Street, Bloomsbury, W.C. Excursions second Sundays, Meetings following Mondays, 8 pm.  
 MALACOLOGICAL SOCIETY OF LONDON, meets in Linnean Society's Rooms, Burlington House. Second Friday each month, November to June, 8 p.m.  
 MINERALOGICAL SOCIETY. Meets in rooms of Geological Society, February 4th, April 14th, June 23rd, November 17th, 8 p.m.  
 NONPAREIL ENTOMOLOGICAL AND NATURAL HISTORY SOCIETY, 99, Mansfield Street, Kingsland Road, N.E. First and third Thursdays, 8 p.m.  
 NORTH KENT NATURAL HISTORY AND SCIENTIFIC SOCIETY, St. John's Schools, Wellington Street, Woolwich. Alternate Wednesdays, 7.30 p.m.  
 NORTH LONDON NATURAL HISTORY SOCIETY, North-East London Institution, Hackney Downs Station. First and third Thursdays, 7.45 p.m.
- QUEKETT MICROSCOPICAL CLUB, 20, Hanover Square. First and third Fridays, 8 p.m.  
 ROYAL BOTANIC SOCIETY OF LONDON, Regent's Park. Second and fourth Saturdays at 3.45 p.m.  
 ROYAL HORTICULTURAL SOCIETY, 117, Victoria Street, S.W. Second and fourth Tuesdays, except December to February; 2 p.m. on show days, which vary.  
 ROYAL METEOROLOGICAL SOCIETY, 22, Great George Street, Westminster. 3rd Wednesday, November to June, 8 p.m.  
 ROYAL MICROSCOPICAL SOCIETY, 20, Hanover Square. Third Wednesdays, October to June, 8 p.m.  
 SELBORNE SOCIETY, 20, Hanover Square. No winter meetings.  
 SIDCUP LITERARY AND SCIENTIFIC SOCIETY, Public Hall, Sidcup. First and third Tuesdays, October to May, 8 p.m.  
 SOUTH LONDON ENTOMOLOGICAL AND NATURAL HISTORY SOCIETY, Hibernia Chambers, London Bridge, S.E. Second and fourth Thursdays, 8 p.m.  
 SUTTON SCIENTIFIC AND LITERARY SOCIETY, Public Hall Chambers. Second and fourth Tuesdays, 8 p.m.  
 WEST KENT NATURAL HISTORY, MICROSCOPICAL AND PHOTOGRAPHIC SOCIETY. Meets in School for Sons of Missionaries, Blackheath, third Wednesday, in December, fourth Wednesdays in October, November, January, February, March, April, May, 8 p.m.  
 ZOOLOGICAL SOCIETY OF LONDON, 3, Hanover Square. First and third Tuesdays, 8.30 p.m., November to August.

## NOTICES TO CORRESPONDENTS.

TO CORRESPONDENTS AND EXCHANGERS.—SCIENCE-GOSSIP is published on the 25th of each month. All notes or other communications should reach us not later than the 18th of the month for insertion in the following number. No communications can be inserted or noticed without full name and address of writer. Notices of changes of address admitted free.

BUSINESS COMMUNICATIONS.—All Business Communications relating to SCIENCE-GOSSIP must be addressed to the NASSAU STEAM PRESS, LIMITED, 86, St. Martin's Lane, Charing Cross, W.C.

SUBSCRIPTIONS.—Subscriptions to SCIENCE-GOSSIP, at the rate of 6s. 6d. for twelve months (including postage), should be remitted to the NASSAU STEAM PRESS, LIMITED, 86, St. Martin's Lane, Charing Cross, W.C.  
 Strictly Editorial communications, *i.e.*, such as relate to articles, books for review, instruments for notice, specimens for identification, etc., to be addressed to JOHN T. CARRINGTON, 1, Northumberland Avenue, London, W.C.

NOTICE.—Contributors are requested to strictly observe the following rules. All contributions must be *clearly* written on one side of the paper only. Words intended to be printed in *italics* should be marked under with a single line. Generic names must be given in full, excepting where used immediately before. Capitals may only be used for generic, and not specific names. Scientific names and names of places to be written in round hand.

THE Editor will be pleased to answer questions and name specimens through the Correspondence column of the magazine. Specimens, in good condition, of not more than three species to be sent at one time, *carriage paid*. Duplicates only to be sent, which will not be returned. The specimens must have identifying numbers attached, together with locality, date and particulars of capture.

THE Editor is not responsible for unused MSS., neither can he undertake to return them, unless accompanied with stamps for return postage.

## EXCHANGES.

NOTICE.—Exchanges extending to thirty words (including name and address) admitted free, but additional words must be prepaid at the rate of threepence for every seven words or less.

WANTED, offers for the whole of SCIENCE-GOSSIP, 1865 to 1897; first 28 volumes in publisher's cover, remainder unbound.—G. P. Bonny, 30, Wellington Road, Stoke Newington, London, N.

MOTHS wanted; will exchange *Hesperia actaeon*.—F. Brown, 22, Holland Road, Kensington, W.

"NATURAL HISTORY," by W. J. Gordon, quite new; will exchange for a few good microscopical slides or offers.—A. Nicholson, Carlton House, Greenbank Road, Darlington.

WANTED, loose old English stamps, also present issue, in exchange for fossils, minerals, British and foreign shells.—Thos. Edwards, Cliftonville House, Equity Road, Leicester.

WANTED, English and foreign Coleoptera; exchange, insects, flowers, algæ, ferns, microscopic material; state desiderata.—D. Dods, Poste Restante, Cape Town, South Africa.

LANTERN slides or photographs in exchange for books or papers relating to natural history, geology, or archæology of Cheshire.—J. Laing, 22, Richard Street, Crewe.

## ZOOLOGICAL NOMENCLATURE.

THE following is a translation, kindly contributed by Miss F. Winstone, of the proposed Rules for Zoological Nomenclature which will be submitted to the International Congress of Zoology, to be held at Cambridge in August next. The draft appeared in the "Bulletin de la Société Zoologique de France" (vol. xxii. No. 8):—

These suggested rules have been drawn up with the object of obtaining, if possible, a final settlement of the zoological nomenclature. In view of this, the Third International Congress of Zoology held at Leyden in September, 1895, nominated an International Commission of five members, who were instructed to study and submit a report upon this important question. The Commission consisted of Messrs. R. Blanchard (for France), J. V. Carus (for Germany), Jentink (for the Netherlands), Sclater (for England) and Wardell Stiles (for the United States). They met at Baden-Baden from the 5th to 9th August, 1897, under the presidency of Professor Carus, when Professor Blanchard was elected reporting secretary. Dr. Jentink excused himself from attendance.

The rules following were adopted unanimously, with slight exceptions, for submission to this year's Congress.

It was decided that the official version to be presented in the German language should be by Professor Carus; that for the English language, by Mr. Wardell Stiles; and that in case of doubt the French text should be used for interpretation.

## OF ZOOLOGICAL NOMENCLATURE.

Clause 1.—The nomenclature adopted for animals is to be binomial. The names are to be Latin. Each animal is to be distinguished by the name of the genus, followed by that of the species. Ex., *Corvus corax*.

Clause 2.—In special cases where it is useful to distinguish varieties, the addition of a third name to those of the genus and species is permissible. Ex., *Corvus corax kamshaticus*.

Clause 3.—It is a mistake to say *Corvus kamshaticus*. In the other case the word *varietas*, or its abbreviation *var.*, between the name of the species and the name of the variety is not necessary. When the word *varietas* is interposed, the name of the variety should agree with it. Ex., *Corvus corax var kamshatica*. If otherwise, the name of the variety should agree with the name of the genus. Ex., *Corvus corax kamshaticus*.

Clause 4.—Hybrids can be named in two ways,

but in both cases the name of the male parent is placed first.

(a) The names of the two parents are joined together by the sign  $\times$ . In this case the use of the sex signs is not necessary. Ex., *Capra hircus* ♂  $\times$  *Ovis aries* ♀ and *Capra hircus*  $\times$  *Ovis aries* are both equally good formulæ:

(b) Hybrids can be equally well named by the use of a fraction, of which the numerator represents the male and the denominator the female. Ex.,  $\frac{Capra\ hircus}{Ovis\ aries}$ . This second method is the most useful, as it enables one to give the name of the first observer of the hybrid form. Ex.,  $\frac{Bernicla\ canadensis}{Anser\ cygnoides}$ , Rabé.

(c) The second kind of formula is preferable when one or the other of the parents is itself a hybrid. Ex.,  $\frac{Tetrao\ tetrix \times Tetrao\ urogallus}{Gallus\ gallinaceus}$ .

One can also write (*Tetrao tetrix*  $\times$  *Tetrao urogallus*)  $\times$  *Gallus gallinaceus*.

(d) When the parents of a hybrid are not known, it takes, provisionally, a simple specific name as if it were a true species, that is to say, not a hybrid; but the generic name is preceded by the sign  $\times$ . Ex.,  $\times$  *Coregonus doliosus* Fatio.

## OF GENERIC NAMES.

Clause 5.—Zoological nomenclature is independent of botanical nomenclature. Nevertheless, it is convenient to avoid in zoology the generic names already employed in botany.

Clause 6.—The name of a genus should consist of one word, whether simple or composite. It should be unique, and either Latin or latinized—to be treated as such even if it does not come from the Latin language.

Clause 7.—Double surnames should have only one of the names composing them used as a generic name. Ex., *Selysius*, *Targionia*, *Edwardsia*, *Duthiersia*.

Clause 8.—Clauses 5 and 7 apply also to subgenera.

## OF SPECIFIC NAMES.

Clause 9.—Specific names, if they are substantives or adjectives, are univocal. Double vocables are, however, used for specific denominations when they denote a person whose name is double, or establish a comparison with a simple object. Ex., *Sanctae-Catarinae*, *Jau-Mayeni*, *cornu-pastoris*, *cor-anguinum*, etc. In this case the two words which make the specific name are always joined together by a hyphen.

Clause 10.—Specific names are :

- (a) Adjectives agreeing in gender with the generic name. Ex., *Felis marmorata*.  
 (b) Substantives in the nominative case are placed in apposition to the generic name. Ex., *Felis leo*.  
 (c) Substantives are in the genitive when they indicate dedication to some person or persons. This genitive is always formed by the addition of an *i* to the exact and complete name of the person, even if the name is like Latin. If the person be a woman *ae* is added. When the dedication is to several persons, it is put in the plural. Ex., *Cuvieri, Möbiusi, Nuñezi, Merianae, antiquorum*.

In the case of a name or Christian name having already been used and declined in Latin, it follows the rules of the declension. Ex., *Plinii, Aristotelis, Victoris, Antonii, Elizabethae, Petri* (Christian name).

Clause 11.—Specific names which are a repetition of the generic name should be avoided. Ex., *Trutta trutta*.

The same applies for triple names when the name of the variety is a repetition of that of the species. Ex., *Amblystomum jeffersonianum jeffersonianum*.

Clause 12.—Local spelling should be adopted when transforming into Latin adjectives names borrowed from a country making use of the Latin alphabet (languages Neo-Latin and Germanic). For the convenience of writing one should adopt the letters marked with the diacritic sign. Ex., *spitzbergensis, islandicus, paraguayensis, patagonicus, barbadensis, färöensis*.

Clause 13.—Geographical names taken from the names of men should be transformed into Latin adjectives in conformance with Clauses 48 and 51. Ex.: *edwardiensis, diemenensis, magellanicus*.

Excepting the names of islands, such as Saint-Paul, Saint-Thomas, Saint-Helena, which should be kept as substantives, but put in the genitive case. Ex.: *Sancti-Pauli, Sanctae-Helenae*.

Clause 14.—Clauses 9 and 13 apply equally to sub-genera.

#### OF THE METHOD OF WRITING THE NAMES OF GENERA AND SPECIES.

Clause 15.—The name of the genus should always be written with a capital first letter.

Clause 16.—Surnames or Christian names used in the formation of names of species can be written with a capital letter. Ex., *Rhizostoma Cuvieri, Francolinus Lucani, Laophonte Mohammed*.

In all other cases the specific name should be written with a small first letter. Ex., *Oestrus bovis, Corvus corax*.

Clause 17.—The legitimate author of a species is considered to be :

- (a) He who is the first to describe and name it in conformity to Clause 1 ;  
 (b) He who, conforming to the same clause, names a species already described but not yet named ;  
 (c) He who substitutes for a name contrary to the above-quoted clause one conforming to the same rule ;  
 (d) He who suppresses a name which has been doubly used, and substitutes a new name.

The name of the author of a species follows the specific name. It is written without a comma and in the same characters as the text following it : supposing that the name of the species is in italics, in roman text ; and in roman, in an italic text. Ex., "*Rana esculenta* Linné lives in France."

Clause 18.—The name of a sub-genus, when it is useful to quote it, is placed in parenthesis between the name of the genus and that of the species. Ex., *Vanessa (Pyrameis) cardui* Linné.

Clause 19.—If it is required to quote the name of a variety or sub-species, it should come third without a comma or parenthesis. The name of the author of this variety or sub-species can be given, also without comma or parenthesis. Ex., *Rana esculenta marmorata* Hallowell.

Clause 20.—When the name of the author of a species or sub-species is quoted in an abridged form, one should conform to the list of abbreviations proposed by the Zoological Museum of Berlin and adopted and slightly added to by the Congress of Paris.

#### OF THE SUBDIVISION AND JOINING OF GENERA AND SPECIES.

Clause 21.—When a genus is subdivided, the old name is kept by one of the subdivisions, and that which contains the original type of the genus.

Clause 22.—When the original type is not clearly indicated, the author who was the first to subdivide the genus can apply the old name to the subdivision he judges best, and this prerogative cannot be altered later.

In other cases one cannot give the old generic name to a group containing none of the original species included in the genus. Neither can one choose as a type a species the description of which applies with doubt to the original genus.

Clause 23.—The division of species is subject to the two preceding rules ; but a specific name which is evidently founded on an error of identification cannot remain even when the species is placed in separate genus. Ex.: *Taenia pectinata* Göze, 1782, and *Taenia pectinata* Zeder, 1800 = *Cittotaenia pectinata* (Göze), and *Andrya rhopalcephala* (Riehm).

Clause 24.—The oldest name is preserved : when a genus becomes a sub-genus or a sub-genus is made into a genus, when a species descends to the

degree of sub-species or a sub-species becomes a species.

Clause 25.—The name of the typical sub-genus should be the same as that of the genus.

Clause 26.—When a species has been finally placed in a genus other than that in which its author placed it, the name of this author is preserved in the notation, but placed in parenthesis, with the date at which the species has been established. Ex., *Pontobdella muricata* (Linné), or *Pontobdella muricata* (Linné, 1758).

The name of the author who has transferred a species into another genus can be placed after the name of the author of the species, but outside the parenthesis. Ex., *Pontobdella muricata* (Linné) Lamarck, or *Pontobdella muricata* (Linné, 1758), Lamarck, 1818.

Clause 27.—When a species is divided, the species to which is given the name of the primitive species can have a notation showing at the same time the name of the author who established the original species and of he who made the subdivision of this species. Ex., *Taenia solium* Linné partim Küchenmeister.

In conformity with Clause 26, the name of the first author is put in parenthesis if the species has been transferred into another genus.

Clause 28.—A genus formed by the union of several others takes the name of the oldest of the genera or sub-genera which compose it.

If the names are of the same date, that which has been chosen by the first reviser should remain.

Clause 29.—The above rule is applicable when several species or sub-species are united into one.

Clause 30.—If, on the joining together of two genera, two animals having the same specific name are in the new genus, the more recent should lose its specific name and receive a new one.

#### OF FAMILY NAMES.

Clause 31.—Family names are formed by adding the termination *idae* to the root of the genus which is the type. Subdivisions of the family are designated by adding the termination *inae* to the name of the genus which is the type.

Clause 32.—The family name should disappear and be replaced if the generic name on which it is founded falls away in the synonym and disappears itself from the nomenclature.

#### OF THE LAW OF PRIORITY.

Clause 33.—Names of genera and species can only be those which were first given on the following conditions:

- (a) That the name has been published in a publication where it shall have been clearly and sufficiently defined;

- (b) That the author has understood and applied the rules of binomial nomenclature.

Clause 34.—The tenth edition of the "Systema Naturae" (1758) is the work to be followed in the general application of the binomial system in zoological nomenclature. The date 1758 is, therefore, accepted as the starting-point of zoological nomenclature and the appearance of the law of priority.

Clause 35.—The law of priority prevails, and consequently the oldest name is the one preserved:

- (a) When any part of an animal has been named before the animal itself;
- (b) When a larva has been named before the imago.

Exception is made, at least for the present, for animals in metamorphosis or migration; many of which species ought to be subjected to a revision, which would result in a considerable overthrow of the nomenclature:

- (c) When two sexes of the same species have been considered as distinct species, or even as belonging to distinct genera;
- (d) When the animal has a regular succession of different generations which have been considered as belonging to distinct species or genera.

Clause 36.—When several names have been proposed simultaneously, without it being possible to establish the priority, the name to be adopted is:

- (a) The name by which a typical species is designated, if it is not already the name of a genus;
- (b) The name which is accompanied by a drawing, a diagnosis, or a description of an adult, if it is not already the name of a species;
- (c) The name chosen by the author of the first revision;
- (d) All things being equal, the name cited in the first place in the work.

Clause 37.—All generic names already in use in zoology are rejected.

Clause 38.—In the same way all specific names already in use in a genus are rejected.

Clause 39.—Names rejected because of homonymy cannot be used again. Names rejected in consequence of synonymy cannot be again employed, except in the case of the restoration of groups suppressed by mistake.

Clause 40.—A generic or specific name once made public cannot be rejected for an improper reason, even by its author.

Clause 41.—All grammatical errors should be rectified. Ex., *Cuterebra* in place of *Cuterebra*, *Glossophonia* in place of *Glossophonia*. However, names of hybrids are kept as such. Ex., *Geovula*, *Vermifilla*.



## RECOMMENDATIONS.

## OF GENERIC NAMES.

Clause 42.—Generic names can be taken :

- (a) From Greek substantives, for which the rules of Latin transcription shall be strictly followed. Ex., *Ancyus*, *Amphibola*, *Aplysia*, *Pompholyx*.  
 (b) From composite Greek words, the attribute of which shall always be placed before the principal word. Ex., *Stenogyra Pleurobranchus*, *Tyrodina*, *Cyclostomum*, *Sarcocystis*, *Pelodytes*, *Hydrophilus*, *Rhizobius*.

As exceptions can be used words formed in a similar manner to the word *Hippopotamus*, that is to say, in which the attribute is after the principal word. Ex., *Philydrus*, *Biorhiza*. However, the words thus formed are vicious and should not be imitated.

- (c) From Latin substantives. Ex., *Ancilla*, *Auricula*, *Cassis*, *Comus*, *Dolium*, *Metula*, *Oliua*. Adjectives (*Prasina*) and past-participles (*Productus*) are not recommended.  
 (d) From composite Latin words. Ex., *Stiliger*, *Dolabrifer*, *Semifusus*.  
 (e) From the derivatives of Greek and Latin words expressing diminution, comparison, resemblance, possession. Ex., *Lingularius*, *Lingulina*, *Lingulinopsis*, *Lingulella*, *Lingulepis*, *Lingulops*, all of which are derived from *Lingula*.  
 (f) From mythological names or the names of heroes. Ex., *Osiris*, *Venus*, *Brisinga*, *Velleda*, *Crimora*. These names take a Latin termination if they have not it already (*Aegirus*, *Göndulia*).  
 (g) From names or Christian names in use in early ages. Ex., *Cleopatra*, *Belisarius*, *Melania*.  
 (h) From modern surnames, when a termination is added which gives them the signification of a dedication.

Surnames belonging to Latin and Germanic languages, or even to any language where the Latin alphabet is used, keep their own spelling with the exception of the diacritic signs with which certain letters can be surcharged. All names ending with a consonant take the terminations *ius*, *ia*, *ium*. Ex., *Selysius*, *Lamarckia*, *Köllikeria*, *Mülleria*, *Ibañezia*. All names ending with one of the vowels, *e*, *i*, *o*, *y*, simply take the termination *us*, *a*, *um*. Ex., *Blainvillea*, *Wyvillea*, *Cavolinia*, *Fatioa*, *Bernaya*, *Quoya*. All names ending in *a* take the termination *ia*. Ex., *Danaia*.

- (i) From names of naval ships, which are treated in the same way as names of mythology (*Vega*) or as modern surnames. Ex., *Blakea*, *Hiron-dellea*, *Challengeia*.  
 (j) From barbarous names, that is to say, taken from any language spoken in a country where there is no scientific movement. Ex., *Vanikoro*. These can have a Latin termination. Ex., *Yetus*.  
 (k) From names formed by any combination of letters whatever. Ex., *Fossarus*, *Neda*, *Clanculus*.

- (l) From words formed by an anagram. Ex., *Verlusia*, *Linospa*.

The names specified in paragraphs *f* and *i* of this article should not enter into the formation of composite words. Generic names such as *Eugrimmia*, *Buchiceras*, *Heromorpha*, *Möbiusispongia* are not recommended.

Clause 43.—Any particles borrowed from the names of men are excluded from generic names, but the articles are incorporated in these names. Ex., *Selysius*, *Blainvillea*, *Lacazea*, *Lacepedea*, *Benedenia*, *Chijsa*. It is scarcely necessary to say that this rule is not applicable in cases where the particle is included in the surname. Ex.: *Dumerilia*.

## OF SPECIFIC NAMES.

Clause 44.—The best specific name is a short Latin adjective of an agreeable sound and easy pronunciation. Greek words latinised, however, or barbarous words which are not declinable, can be used. Ex., *hipposideros*, *echinococcus*, *zigzag*.

Clause 45.—The prefixes *sub* and *pseudo* can only be used with adjectives or substantives; Latin for the first, Greek for the latter. Ex., *subterraneus*, *subviridis*, *Pseudacanthus*, *Pseudophis*, *Pseudomys*. They cannot be used with proper nouns. Denominations *sub-Wilsoni* or *pseudo-Grateloupana* are very vicious.

Clause 46.—The termination *ēdos*, or its Latin form *ides*, can only be used with a Greek or Latin substantive. It cannot be used with a proper noun.

Clause 47.—If the specific name requires the use of a geographical name this ought to be put in the genitive case, or as an adjective if it was known to the Romans, or if it was latinised by writers of the Middle Ages. In the adjective form it is always written with a small first letter. Ex., *Antillarum*, *Galliae*, *lybicus*, *aegyptiacus*, *graecus*, *burdigalensis*, *iconensis*, *petrocoriensis*, *parisiensis*.

Clause 48.—All geographical names which do not come under the preceding catalogue are made into adjectives, following the rules of Latin derivations, but preserving the exact spelling of the root, if this has not been used in Latin. Ex., *neobatus*, *islandicus*, *brasiliensis*, *canadensis*.

Clause 49.—(This clause refers only to France.)

Clause 50.—In compliance with Clause 12, and in spite of the diacritical signs with which letters are surcharged, the original spelling should be preserved of proper names borrowed from certain Slav languages (Polish, Croatian, etc.), and in general from all languages in which the Latin alphabet is used. Ex., *Taenia*, *Medici*, *Congeris*, *Cžjžeki*.

## LAW OF PRIORITY.

Clause 51.—If the root of a geographical name forms, in Latin, two derivative adjectives (Ex., *hispanus* and *hispanicus*) they cannot be used concurrently in the same genus.

Clause 52.—The same holds good for common nouns. Nouns such as *fluviorum*, *fluvialis* and



*furcatis* are considered as being doubly used if employed in the same genus.

Clause 53.—It is very desirable that every original description of a new genus or a new species should be accompanied by a Latin diagnosis, at once individual and differential; or, at least, a diagnosis in one of the four European languages best distributed (English, German, French, Italian).

Clause 54.—In works which are not published in any of these four languages, it is very desirable that the explanations of the figures and plates should be wholly translated into Latin or into any of these languages.

Clause 55.—Words are to be avoided which are only distinguished by a masculine, feminine, or neuter termination, or only by a slight change of orthography.

#### COLLATERAL QUESTIONS.

Clause 56.—The metric system only is employed in zoology for valuation of the measures. The foot, inch, pound, ounce, etc., ought to be rigorously banished from scientific language.

Clause 57.—Altitudes, depths, speed and all general measures should be expressed in metres. Fathoms, knots, marine miles, etc., ought to disappear from scientific language.

Clause 58.—The thousandth of the millimetre ( $0^{mm\cdot001}$ ), represented by the Greek letter  $\mu$ , is the unit of measure adopted in micrography.

Clause 59.—Temperatures are expressed in degrees of the centigrade thermometer of Celsius.

Clause 60.—Indication of enlargement or of reduction is indispensable for the proper understanding of a drawing. It is expressed in cyphers, and not by mentioning the number of the lens by the aid of which the image was obtained.

Clause 61.—It is useful to indicate if there is a lineal enlargement or an increase in the surface. This can be easily abridged. Ex.,  $\times 50$  times  $\square$  means an increased bulk of 50 times on the surface;  $\times 50$  times — indicates a lineal increase of 50 times.

Then follow the rules for the writing of geographical and proper names which were adopted by the International Congress of Zoology.

## HOW FLOWERS ATTRACT INSECTS.

By G. W. BULMAN.

IT was Sprengel, Rector of Spandau, near Berlin, a botanist so enthusiastic as to neglect his duties as Pastor, and consequently to lose his post, who first directed attention to the fertilization of flowers by insects, and to the wonderful way in which the former are adapted to the visits of the latter. After undergoing a period of neglect, the idea was taken up and given a fresh development by Darwin and his followers; but in a different way.

By far the most exhaustive series of experiments which have ever been carried out on this subject are those of Professor Plateau, of the University of Ghent. These point irresistibly to the other possibility. It is, I believe, beyond dispute that these experiments show that insects are not attracted to flowers by their gay colours. An account of these very interesting observations, under the title of "Comment les Fleurs attirent les Insectes," has appeared from time to time in the "Bulletins de l'Académie Royale de Belgique." I propose to give here very briefly an outline of them.

Having covered the gaily-coloured flowers of single dahlias with green leaves, in some cases the outer ray florets only, in others the whole flower, Professor Plateau found that insects visited them as freely as before. Such a result, so much at variance with the generally received view that insects are attracted to flowers by their gay colours, seemed to demand further investigation. So Professor Plateau set himself by a series of experiments

and observations exhaustively to cross-question nature on the subject. The final answer has been a confirmation of the conclusion pointed to in the first experiments, viz., that colour plays a very subordinate part in attracting insects to flowers.

The first question put was, "If the gaily-coloured part of a flower be removed, leaving only the green calyx and the honey-bearing parts, will insects still visit it?" To put this question, Professor Plateau took two pots of lobelia, each with thirty or forty flowers, and carefully cut off with a pair of scissors all the blue corollas in the one pot, leaving those in the other intact. These pots were placed near together in a sunny situation much frequented by insects. Watching them carefully, thirty-three visits to the blue flowers and twenty-five to the green calyces were counted. When Darwin put the question with the same flower he got an opposite answer. For having deprived some lobelia flowers of their blue corollas he found that the bees ceased to visit them.

Professor Plateau continued his questions with other flowers. He cut off the large, conspicuous yellow corollas of the evening primrose. One bee was seen to visit fourteen of these mutilated flowers in succession. On another occasion one bee visited ten, another three and another fifteen of these flowers without corollas. Similar results were obtained with the flowers of *Convolvulus major*, larkspur, cornflower and foxglove. When, how-

ever, the question was put with snapdragon the answer seemed different; insects did not visit the remaining green parts. Professor Plateau thinks this may have been because the mouth of the green calyx of this flower is directed upwards, while insects generally attack such flowers from below. In any case one negative answer cannot alter the obvious conclusions from the many positive ones.

Another answer to the question comes from the well-known fact that insects pass freely from one colour to another among our garden flowers. Professor Plateau rightly claims this as supporting his view. He himself has seen them pass freely from colour to colour in a bed containing blue, purple, rose, and white cornflowers; in a patch of red, scarlet, purple, rose, yellow, orange and white single dahlias; and from the vivid red of the garden flax to the bright blue of the common flax. Other writers, including Darwin, have observed the same thing.

The question, however, may be put in another form. There are certain brilliantly-coloured flowers which insects scarcely ever visit. Now, if insects are attracted rather by perceiving in some way that honey is present than by the colours of flowers, then they ought to be attracted to such flowers when honey is placed in them. So Professor Plateau chose the scarlet geranium of our gardens, and placed some honey on a few of the flowers. In the course of an hour these honeyed flowers were visited by eight humble bees; and when these bees, in the course of gathering honey from these honeyed flowers, came to those without it, they flew over them without alighting. Phlox, Japanese anemone, and the larger bindweed were treated in the same way, and with similar results.

Again, if the honey-bearing parts of flowers be removed, leaving the gay corolla, then, if insects are not attracted chiefly by colour, they should cease to visit them. The question was then put in this form. The central florets of single dahlias, which alone secrete honey, were carefully removed, and bits of yellow leaf put in their place. No insects came to visit the flowers thus treated. As soon as a drop of honey was placed on these artificial discs, then insects were attracted as freely as before. The discs were then removed, and a little honey placed in the central space. Again insects were quickly attracted.

Another answer comes from the habits of insects in visiting flowers. There are a number of plants with inconspicuous flowers, usually fertilized by the wind, and hence known as "anemophilous." These have no gaily-coloured corollas to advertise their honey or pollen, yet not a few of them, as certain species of *Chenopodium*, nut, docks, rushes and grasses are, on authority of various authors, visited by insects. Insects would not visit these flowers if they required the stimulus of colour to attract them.

Yet again, the question may be put in another form. If insects are attracted to flowers not by gay colour, but by the perception of honey, then if honey be placed in such inconspicuous anemophilous flowers as are seldom or never visited by insects, the latter ought then to be attracted. This was found to be the case. Honey was placed on seventeen species of such flowers, including *Chenopodium*, hemp, hop, nettles, reeds and grasses, and in each case insects were attracted.

We ought also to obtain an answer to our question by noting the colours of flowers freely visited by insects. If they are chiefly drawn by gay colours, then we should expect to find them rather avoiding the green and inconspicuous ones. So Professor Plateau brings forward a list of green, greenish, brown, or brownish flowers, freely visited by insects. This list, containing ninety-one species in all, includes such flowers as hellebore, ladies' mantle, ivy, currants, figwort, spurge, asparagus, lime, sycamore, raspberry, wood sage, etc. All these, on the authority of Professor Plateau himself and others, are freely visited.

Professor Plateau's final questionings were made with artificial flowers. These were made to imitate lilac, forget-me-not, saxifrage and foxglove. Being placed among natural flowers they entirely failed to attract insects. Even when honey was placed in them none came. Obviously, then, insects are not attracted by such artificial colours. The fact that even honey failed to bring them seems to show that they had some distrust of the artificial flowers. Then Professor Plateau altered the form of this final question. He now made some artificial flowers of bits of green leaves of red currant and of sycamore, placing a little honey in each. To these strange looking flowers, unlike anything they had seen before, insects came freely for the honey.

From all this cross-questioning of nature Professor Plateau claims to be entitled to draw the following conclusion: "Insects seem to care little either for the presence or absence of floral parts of brilliant colours. That which they desire is pollen or nectar, and they are guided in a very subordinate way by sight, but on the contrary in a sure way by another sense, which can only be smell."

If we admit his facts we cannot escape from Professor Plateau's conclusions; no explaining away is possible. But if we accept the inference that insects are not attracted to flowers by their gay colours, can we retain a belief in the insect selection theory of the origin of flowers? Giving up the assumption that brilliant colours are the attraction and guide to insects, we take away a plank from the hull of the little barque of theory which has sailed so gaily these many summers over the seas of popular scientific literature; and the leak is fatal.

## GEOLOGICAL PHOTOGRAPHS.

THE eighth report of "The Committee of the British Association on Photographs of Geological Interest in the United Kingdom," which was presented at the Toronto meeting last year, is issued in pamphlet form. Three hundred and sixty-four new photographs had been added to the collection, which then reached 1,751. The loan collection numbered 691 prints and slides. The list showed that eight new counties were partially represented, and additions had been made in eleven others. An important addition was the valuable gift by Mr. R. Welch, of Belfast, of 100 new platinotypes which, "in addition to their artistic merit are, from a strictly geological point of view, so good that not one could be spared from the collection." This gift from Mr. Welch is an addition to the fifty prints given by him in previous years, and to the twenty-five duplicates and seven slides which accompanied his last donation.

The Committee invite donations of suitable unmounted photographs from "areas of large and typical physical features, such as the Pennine and Pendle ranges, the South Wales coalfield and its borders, the district of the Arans, Arenigs, and Cader Idris, the Harlech mountains, the Yorkshire dales, the Cotswolds and South Downs, the Malverns, and the Silurian ground on the Welsh border, the Yorkshire moors, Lincolnshire, the area of the Northampton Oolites, the Oxford district, Seaton and Blackdown, Central Wales and Anglesey. In Scotland: the North-West and Central Highlands, the outer Hebrides, Mull, the Sidlaws, and Ochil Hills and Southern Uplands. In Ireland: the Carlingford and Slieve Gallion areas, Kerry, Cork, the Limerick basin, Waterford and Wicklow."

The Committee states that it is difficult to get those who are not geologists to take any interest in the subject, and almost impossible to persuade them to photograph objects solely for their geological value. Still, unconsciously, photographs of much scientific interest are occasionally taken by both amateur and professional photographers of landscape or scenery, exhibiting the geological features of the district. Consequently the Committee invite those who have albums of such prints to submit them to the Committee, so that they may be critically examined with the object of obtaining copies of such prints as are of permanent geological interest. At present the collection contains photographs of what may be called the more sensational geological phenomena. What is wanted is the steady photographic survey of ordinary or temporary features and phenomena. Certain points on retreating or advancing shore lines should be photographed

at regular intervals. Sections of variable deposits should be secured as the excavation of them proceeds. Out-of-the-way districts should be also registered, even if yielding ordinary features.

Much labour has been expended upon getting the collection into thorough order. The prints are mounted on standard interchangeable guarded mounts. With these are descriptive inscriptions, explaining the subjects depicted and the localities accurately identified. They are classified geographically and grouped according to the countries and counties to which they belong. At present the collection occupies twenty-three albums, so arranged that their contents can be expanded in proper sequence as new prints are acquired. There is a card index to the whole, so that any present or absent can be immediately ascertained.

This remarkable and scientifically valuable collection is deposited in the library of the Museum of Practical Geology, 28, Jermyn Street, adjoining Piccadilly Circus, London. It is, therefore, easily accessible to visitors, who have only to apply to the Librarian for permission to examine. This museum is open free to the public, and is in itself one of the finest in Europe.

It may be remarked that, although this Committee has only been in existence a few years, their efforts have secured lasting pictorial evidence of geological features which have disappeared in the interval, through the action of the sea or other physical causes.

The Committee hopes, in addition to maintaining the central collection above described, to prevail on donors to furnish duplicate prints, so that loan collections may be formed for circulation among geological and other scientific societies in various parts of the kingdom. This would indeed be good work, especially if accompanied by a full description of the pictures, which might be read as a popularly scientific paper, illustrated by the prints or lantern slides. The only charge to be made for the loan of these duplicate collections is to be for the cost of carriage and expenses of packing.

Any geologist who is desirous of making a collection of prints of this character may readily do so, as copies of numbers of the pictures contained in the Committee's collection can be acquired by purchase or exchange direct from the original photographers. A copy of the report containing a list of the collection may be obtained by writing to the secretary, when addresses of the artists will be found.

The Committee supplies forms to facilitate uniformity in the descriptions. These may be obtained by intending donors from the Secretary, Prof. W. W. Watts, Mason College, Birmingham. J.T.C.

## ARMATURE OF HELICOID LANDSHELLS,

WITH A NEW FORM OF PLECTOPYLIS.

BY G. K. GUDE, F.Z.S.

(Continued from page 264.)

*PLECTOPYLIS DIPTYCHIA* (figs. 71a-f), from the province of Kouei-Tchou, China, was described by Dr. von Möllendorff in the "Jahrbuch der Deutschen Malakazologischen Gesellschaft," xii (1885), p. 390, and the shell was figured in the same work, t. 10, f. 17. No figure of the armature, as far as I have been able to ascertain, has hitherto been published; my readers will, therefore, be glad to be able to form an idea of these structures from the accompanying figures. The shell is dextral, discoid, light corneous, thin, sub-pellucid, finely striated, decussated with microscopic spiral lines above, shining below, widely and deeply umbilicated. The cuticle is produced into distant plaits, which are very prominent at the periphery. The spire is a little raised, and the suture is impressed. There are six narrow whorls, which increase slowly and regularly, the last is angulated above the periphery, rounded below, not deflected in front. The aperture is roundly lunate, oblique; the peristome white, a little thickened and reflexed, the margins scarcely united by the parietal callus, which is devoid of any ridge at the aperture. The parietal armature consists of two strong vertical plates, slightly converging above; the anterior one curved, with the convex side towards the aperture, giving off anteriorly at the upper extremity a short horizontal ridge, and being a little deflected

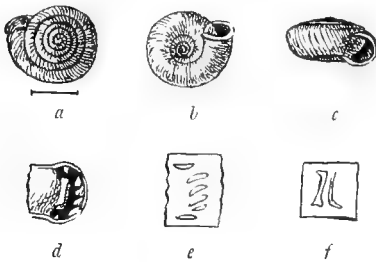
Fig. 71.—*Plectopylis diptychia*.

posteriorly below. The posterior one is crescent-shaped, strongly deflected posteriorly below (see fig. 71f, which shows the parietal wall of the shell with its two plates). The palatal armature is composed of six short, more or less horizontal folds; the first very minute, near the suture; the second, third, fourth and fifth obliquely deflected posteriorly; the sixth horizontal (see fig. 71e, which shows the inside of the outer shell-wall with its folds). The specimen figured measures: major

diameter, 6 millimetres; minor diameter, 5 millimetres; altitude, 3 millimetres. It was sent to me by Dr. von Möllendorff, and is now in my collection. All the figures are enlarged.

*Plectopylis murata* (figs. 72a and b), from Tchen-K'eou, China, was described and figured by Mr. Heude, in Part 2 of his "Notes sur les Mollusques terrestres de la Vallée du Fleuve Bleu" (1885), p. 112, t. 30, f. 1. The shell is dextral, discoid,

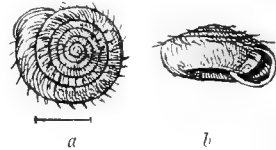
Fig. 72.—*Plectopylis murata*.

light corneous, finely striated and decussated with microscopic spiral lines above, smooth and shining below. On the upper side, the cuticle is produced into distant persisting plaits, which form a coarse fringe around the periphery. The spire is a little elevated, and the suture linear. There are five and a-half to six whorls, which increase regularly, and are flattened above and rounded below; the last does not descend in front, and is keeled at the periphery. The aperture is rounded, oblique; the peristome white, a little thickened and reflexed, its margins being united by a slight ridge on the parietal callus; the umbilicus is wide and deep. The parietal armature is similar to that of *Plectopylis stenochila* (see my note in this series of papers, SCIENCE-GOSSIP, N. S., Vol. iii, p. 204, figs. 29b and d), and is as variable as in that species. The number of denticles in front of the vertical plate in *Plectopylis murata* varies from one to three, or such denticles may be absent altogether, while the upper and lower short horizontal folds in front of the vertical plate, may be reduced to denticles. The palatal armature is also similar to that of *Plectopylis stenochila* (*loc. cit.* figs. 29c and d), to which species the present one is closely allied, but the shell is more depressed, and the whorls are flattened above with the base shining and translucent, while in *Plectopylis stenochila* the whorls are rounded above with the base striated and opaque. In the species under consideration there are only five and a-half to six whorls, and the umbilicus is more widened at the last whorl, which is keeled at the

periphery, and the fimbriae are coarser, longer and more persistent. The specimen shown in figs. 72 *a* and *b*, from Sse-Tchuan, China, is one of two sent to me by Dr. von Möllendorff; it measures: major diameter, 7.5 millimetres; minor diameter 6.5 millimetres; altitude, 3.75 millimetres.

*Plectopylis trochospira* (figs. 73*a-e*), from Mount Licos, Cebu, Philippine Islands, was described by Dr. von Möllendorff in the "Jahrbuch der Deutschen Malakozoologischen Gesellschaft," xiv. (1887), p. 273, and the shell was figured in the same work, t. 8, f. 9. The armature, however, was not illustrated, and I believe the figures now given are the first which have appeared. The shell is dextral, widely and deeply umbilicated, depressed-conical, light corneous, finely ribbed above and striated below. The spire is conical and the suture impressed. There are six narrow rounded whorls, which increase slowly and regularly; the last, considerably wider than the penultimate, has a thread-like keel at the periphery, is angulated round the umbilicus and does not descend in front. The aperture is diagonal, lunate; the peristome white, a little thickened and reflexed, the margins being slightly convergent and united by a scarcely raised sinuous ridge at the parietal callus. The parietal armature consists of two long, parallel, horizontal folds, which revolve over nearly half a whorl, the upper one being the stronger and united to the ridge at the aperture, while the lower one is thinner

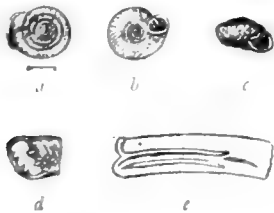

Fig. 73.—*Plectopylis trochospira*.

and terminates at a short distance from the ridge; a very thin, short horizontal fold occurs posteriorly a little below the upper fold (see fig. 73*c*, which shows the parietal wall of the shell with its folds). The palatal armature is composed of five short, thin, horizontal folds, which descend a little anteriorly (see fig. 73*d*, which shows both the parietal and the palatal armatures from the posterior side). The specimen figured is in the collection of Professor Oscar Boettger, of Frankfort, by whom this shell—which measures: major diameter, 4 millimetres; minor diameter, 3.5 millimetres; altitude, 2 millimetres—was obligingly lent to me.

*Plectopylis trochospira* is allied to *P. quadrata* (ante p. 71, f. 54), but it is larger and much lighter in colour; there are also certain differences in the armature.

*Plectopylis trochospira*, var. *boholensis*(<sup>1</sup>). Two specimens kindly lent to me by Mr. Ponsoby, labelled with the manuscript name, "*Plectopylis trochospira*



Fig. 74.—*Plectopylis trochospira* var. *boholensis*.

var. *boholensis* (Möllendorff)," certainly represent a distinct variety. They are smaller than the type, and the umbilicus is narrower. The armature is nearly identical, but the palatal folds are connected at their posterior terminations by a very slight transverse sinuous ridge, plainly discernible externally through the shell-wall.

(To be continued.)

## MINERAL PHOSPHORESCENCE AND X-RAYS.

IN the early part of last year, Mr. John E. Burbank, of the Jefferson Physical Laboratory, Harvard University, was experimenting on fluorescent screens for the X-rays. His attention was directed to the fluorescence of minerals under the action of these rays. He followed up the subject with some notable results, which, though probably not entirely new, are interesting.

Fluorite, when exposed to X-rays, phosphoresces with a bluish-white light, which continues for a long time after being removed from the influence of the rays.

About two-thirds of the minerals tried were found to be phosphorescent to a greater or less degree, the group containing calcium is most susceptible to the action of these rays. Of sixteen specimens tried, twelve of this group were phosphorescent, with light varying from pure white to yellowish red. The felspar group is also acted on by the rays, as are some others of the silicates; but the general ore-bearing minerals are non-phosphorescent.

It is well known that heat and light radiations produce luminous effects in the case of mineral crystals. Apparently these effects are very much like those set in motion by the X-rays; but if the crystals are heated and then exposed to the radiations coming from X-rays the character of the light is often changed. In his description of these experiments, Mr. Burbank mentions that this is the case with glass, fluorite and calcite. In a few cases the light is intensified after the mineral crystals have been heated.

(1) *Plectopylis trochospira* var. *boholensis*, n. var. (fig. 74), differs from the type in being smaller and having a narrower umbilicus. Major diameter, 3.25 millimetres; minor diameter, 3 millimetres; altitude, 1.75 millimetres. Habitat, Bohol Island, Philippine Islands. Type in Mr. Ponsoby's collection.

## ORCADIAN RAMBLES.

BY ROBERT GODFREY.

*(Continued from page 262.)*

## IV.—BIRD-LIFE AROUND KIRKWALL.

MAY 28th opened raw and misty, and suggested the advisability of my changing quarters rather than remaining inactive. Accordingly I took the mail-boat to Scapa, from which place a good road, of a little over a mile in length, leads to Kirkwall. The region there was well-cultivated, with no bleak aspect in the nearer ground, though here and there the cornlands were intersected with strips of pasture, and a guardian range of hills, half hidden by mist, rose on my left. In front, the imposing spire of St. Magnus Cathedral formed a prominent landmark, and the short distance to the town, presenting little of novelty, was soon covered. Just before entering Kirkwall I heard a sedge-warbler singing amongst some flags by the side of a little stream; otherwise, I had as companions the ever-constant larks, with corncrakes and buntings.

After procuring a room, I wandered out of town to inspect the woodlands in its neighbourhood, hoping to meet with some of the more recent colonists amongst their bird life. Though Orkney is by no means so bleak as Shetland, it is unsuited to the proper cultivation of trees, and contains very few plantations worthy of notice. These few, however, have proved attractive resorts for woodland species of birds, and have no doubt tempted many a migrant to linger within their precincts. During a flying visit to Grainbank in 1896 I heard a warbler, which I considered to be a blackcap, singing within the shelter of some thick undergrowth, but my efforts to catch a glimpse of it from the road were unavailing. On the present occasion I was exceedingly anxious to meet with this stranger again, and naturally turned towards Grainbank first. I rested on the verge of the plantation to wait for some strange note, but I heard nothing save the ceaseless chirruping of sparrows and the song of a blackbird. Mist was hanging on the hills at the time, but whether this had any effect in silencing birds I cannot tell.

After an unavailing wait here, I turned towards Muddiesdale, and gaining access to its privacy, lingered there undisturbed, and noted carefully its bird life. This plantation is hemmed in by a dyke on every side, and is in the main a fine grassy park occupied by trees not too closely placed together. The chief trees were larch, though a few sycamore, hawthorn, beech and other kinds also occur. As at Grainbank, sparrows prevailed, but soon another note struck on my ear, and, following it up, I

came on a nestling robin by the side of the little burn that trickles through the wood. I sat down on the bank to allow of the birds resuming their normal activity, and in a short time heard a yellowhammer repeatedly sing, and a blackbird also. I found a blackbird's nest torn out of a tree, and shortly afterwards frightened a greenfinch from her nest, with four eggs, in a larch. A careful search revealed only one other occupied nest, a blackbird's with three eggs, also situated in the crown of a low larch. I failed to find any larger species tenanted the wood, though I came on the castings of an owl containing the remains of field-voles, and picked up a single pigeon's feather. Starlings were flying about commonly, and an occasional redshank or peeweeep would call in passing over, whilst robin, greenfinch and yellowhammer repeatedly uttered their distinctive notes. The breeze blowing through the trees, and the bright sun now dispelling the morning mist, rendered the wood a delightfully refreshing spot, but the comparative paucity of life within its bounds was disappointing to one whose day-dreams had beforehand raised expectation so high.

Around Kirkwall cultivated ground prevails, and the bird-life does not greatly differ, except in being less varied, from that met with in similar haunts farther south. Rooks and jackdaws are common about the town, whilst starlings simply swarm, and buntings, corncrakes, twites and other species are comparatively abundant. At a distance of three miles or less from town, however, the cultivated land gives way to pasture and heather hills; these surpass the hills within easy range of Stromness in their excellent covering of heather and rushes, which is in many parts knee-deep, and offers most enticing retreats for skulking birds. In bird-life the most conspicuous difference lay in the relative numbers of the peeweeep; this species, so abundant all about Stromness, was, by comparison, rare around Kirkwall, and altogether absent from parts of the hills. Golden-plover and meadow-pipit were the chief inhabitants of the hills, and starlings nested in the ground as on the Orphirs. Redshanks and snipe frequented the lower-lying portions, and a curlew in breeding excitement closely attended me on the hills. A few grouse also found shelter in the splendid heather, and a pair of shelducks may have had their nest in some hole there, as I watched them come up from the sea, and later on saw only one of the pair return.

My attention, however, was devoted to a continued search for the hen-harrier and the short-eared owl, both of which species were reported to be fairly common around Kirkwall. With regard to the harrier I found every man's hand raised against it, and I wondered how it continued to survive at all. I had several places noted as haunts of the species, but I failed to find the bird in any of them. In a different district, however, I fell in with the species somewhat commonly, as I hope to notice in a following paper.

With regard to the short-eared owl, I found it as common on the east side of the island as on the west, and judging from the skulking nature of the bird, I had reason to believe that it was much commoner than it even appeared. Though it gave few opportunities for the study of its habits, it now and again rose without the necessity of a disturber being present. On one occasion, during mist, a bird rose within a comparatively short distance of me and began to hunt. At no great

height from the ground it beat carefully along with wide sweep of its long wings, and its short thick-set neck ever conspicuous as it gazed earthwards. For a second or two it halted motionless with its wings upturned through a third of a right-angle, and, having proved the heather and rushes beneath to be tenantless, it beat on again. In a brief space it renewed its hovering, and after repeated advances and many halts it dropped at last to the earth, but rose again, without any prey, to resume its hunt, and finally dropped behind a mound. Here it remained sufficiently long to lead me to infer that it had caught and devoured something, but later on it rose to renew its hunting.

The short-eared owl, during the opportunities I had of observing it, was a very silent species; only once did I hear one cry, and on that occasion the bird seemed to be joining his alarm with that of a male harrier that had been calling uninterruptedly because of my presence.

(To be continued.)

## THE EVOLUTION OF THE ANIMAL CELL.

By JOSEPH SMITH, M.R.I.A., F.L.S.

(Continued from page 253.)

PROTOPLASM is composed of a large number of different chemical substances, and of the chemical nature of the matter our present knowledge is most unsatisfactory. It must be remembered that "protoplasm is not a chemical, but a morphological conception; it is not a single chemical substance, however complex in composition, but it is a matter composed of a large number of different chemical substances, which we have to picture to ourselves as most minute particles united together to form a wonderfully complex structure" (1). Another feature of the substance is that it cannot be placed under changed circumstances without ceasing to be protoplasm, for the properties essential for its formation and on which its existence or vitality manifests itself depend on a fixed organization. Hence after the organization which forms the substance has been destroyed the matter no longer represents protoplasm.

Another feature which is of great importance in the evolution of the protoplasmic mass is that the bodies requisite for its substance can only be produced from the parent mass, in other words, protoplasmic bodies can only be produced from living protoplasm, hence it must be regarded that the growth, or organization, of perfect protoplasm must be the result of very long development.

In considering the nature of this wonderful substance considerable importance must be attached to the fact that it is exceedingly difficult to appre-

ciate or determine the nature of the chemical substances which constitute the mass, on account of the continual changes which take place in its functional progress, as also because of the unstable condition of the elementary units, since any interference with them essentially materially alters their constitution. Further, difficulty is experienced on account of the presence of many products which are considered as waste products, and not easily separated from the cell contents. Amongst these complex substances may be signalized "*proteids*," which are of "especial importance as being the true substances of vital processes" (2).

In proteids carbon occurs combined with four other elements—hydrogen, oxygen, nitrogen and sulphur, in proportions which it has been endeavoured to express by the following formulæ:— $C^{72}, H^{106}, N^{16}, SO^{22}$ —the chemical composition of a molecule of egg albumen.

Amongst the various kinds of proteid bodies—albumen, globulins, fibrins, plastins, nucleins, etc.—plastin alone is apparently the only one peculiar to protoplasm (3).

(1) "These proteids are the most complex of all known organic substances, but until now very little has been determined as to their chemical structure. This complex structure depends, in the first place, upon the very remarkable properties of carbon." Haeckel, "Generale Morphologie."

(2) Reinke u. H. Kollonwald, "Studien über das Protoplasma Untersuchungen am dem Botanischen Institut der Universität Göttingen." (Heft. 2, 1887). Frank Schwartz, "Die Morphologische und Chemische Zusammensetzung des Protoplasmas." Beiträge zur Biologie der Pflanzen" (Bd. IV, Breslau, 1887). Zacharias, "Ueber Eiweiss, Nuclein und Plastin." Botanische Zeitung, 1887.

(3) "The Cell," p. 12. Hertzog.

Plastin is insoluble in water, in ten per cent. salt solution and in ten per cent. solution of sulphate of magnesia; it is precipitated by weak acetic acid, while concentrated acetic acid causes it to swell up. It resists both pepsin and trypsin digestion; it is hardly or not at all stained by baser aniline dyes, but it is stained with acid ones, such as eosin, etc. (4).

Living protoplasm is distinctly alkaline, and moreover the metabolic products demonstrated in protoplasm are most different; they are attributed either to metamorphic progression or retrogression, and as an illustration of the similarity of the constitution of animal and vegetable cells, the following substances are common to both—pepsin, diastase, myosin, sarcin, glycogen, sugar, inosit, dextrin, cholesterin, and lecithin, fat, lactic acid, formic acid, acetic acid, butyric acid, etc. Kossel quotes in his text book the quantitative analysis of (5) a cell as made by Hoppe Seyler, the substance being pus corpuscles. One hundred parts of the substance, by weight, being taken, gave the following results:

Various albuminous substances	-	13'762
Nuclein	- - - -	34'257
Insoluble substances	- - -	20'566
Cholesterin	- - - -	7'400
Cerebrin	- - - -	5'199
Extractives	- - - -	4'433

The ash yields the following substances—phosphorus, sodium, iron, magnesium, calcium, phosphoric acid and chlorine.

As I have previously urged, the discovery of animal protoplasm was induced by the investigation of the constituents of the vegetable cell, the nuclei, large coloured granules, etc., becoming objects of investigation by those interested in the fruits of scientific discovery. Protoplasm being recognised as the base matter or matrix from which the animal and vegetable bodies are built, naturally excited attention, more especially as to the functional action of the nuclei, etc., and so introduced the apparently structureless mass of homogeneous matter into the field of speculative theory. When the action of the nuclear and granular bodies was being worked out, the affinity between these and the structureless mass suggested itself, with the result that the mass was found, in place of being structureless as had hitherto been the idea, to be possessed of a very well-defined formation, which originated several theories.

This matter was originally regarded as consisting of a viscid mass of a more or less homogeneous nature with granules, *i.e.* microsomata, embedded therein; the viscid mass, being more or less con-

tractile, enabled the granules to move about, so that often arranging themselves in rows, they caused the substance to assume a fibrillar appearance. This led others, and amongst them Flemming (6), to regard the matrix as not being of a homogeneous nature, but divided up by fine contractile fibrillae, between which, or within which—it was not definitely stated—the granules assumed their place. The fibrillae vary in length, being in some cells longer than in others, but what their chemical composition was Flemming did not enlarge on. Kunstler was induced, from the examination he made of the flagellate protozoa, to consider protoplasm to be more or less vacuolated in structure, on account of the existence of what he regarded as small vesicles; but further researches resulted in the generally accepted theory that protoplasm was not a homogeneous matrix formed of an accumulation of vesicles, but was possessed of a structure in appearance like network. These trabeculæ consist of a colourless hyaline, within which are embedded the darker granules or microsomata. The meshes, however, form only a sponge-like framework, the interstices being filled in with a liquid or viscid sap, the chynema (7). Strasburger (8), an eminent observer and careful naturalist, and one of the most able exponents of the reticular theory, adopted this view. This definition of protoplasm did not, however, fully account for the peculiar activity which the substance was endowed with, and it occurred to Butschli, who had been investigating the structure of protoplasm, that to arrive at a correct and comprehensive idea of the structure of the substance, it must be from the physical and morphological conditions of life that any attempts to investigate its properties must be undertaken. With this end in view he was, after several experiments, able to produce eventually a substance which to his mind fully exhibited the appearance of protoplasm when viewed under the microscope, and which was apparently endowed with some of the characteristic mechanical movements of living protoplasm, the substance assuming for considerable periods of time—even days—the amoeboid movement of naked masses of the substance. This experiment caused Butschli to conclude that the phenomenon of movement exhibited in protoplasmic masses could not be attributed to the voluntary action of the living protoplasm, but resulted from the physical structure of the substance, which structure he considers to be made up of a mass of small vesicles (9).

(6) Flemming. "Zellsubstanz, Kern und Zelltheilung." Leipzig, 1882.

(7) Manchester Microscopical Society's Transactions, 1893. "The Structure of Protoplasm." Weiss.

(8) "Studien über das Protoplasma." Jenaische Zeitschrift, 1876. Bd., x.

(9) Butschli. "Ueber die Structur des protoplasmas verhandlungen des Naturhist-Med-Vereins zu Heidelberg." N., F., Bd., iv., Heft. 3, 1889. Heft. 14, 1896. See "Quarterly Journal Microscopical Society," 1890.

(4) "The cell," O. Hertwig. Translated by Campbell. London, 1895. Swan, Sonnenschein and Co. p. 17.

(5) Schieferdecker u. Kossel. "Gewebelehre mit besondere Berücksichtigung des menschl. Körpers."



In the structure of protoplasm, however, many qualities are attained, the attributes of which being invisible are consequently entirely unknown to us, and which undoubtedly determine the course of certain developments. Yet the knowledge we possess of the structural formation of the substance sufficiently demonstrates that living protoplasm is not merely an organic substance, but that it is an organized aggregation of molecules of organic matter confined into groups and ultimately forming the particles of living matter. The essence of living matter being in a constant state of change, these particles, supposing that at any period of their existence they were alike, would become altered in their state or appearance. Hence it has been questioned whether these particles or micellae are of the same nature, or whether they may not possess different inherent qualities causing changes in the growth of the protoplasmic mass, which may determine the growth in many animals. Consequently these units, or micellae, may be regarded as the carriers or germs of any inherited peculiarities. Hertwig tell us <sup>(10)</sup> that, "with the means of investigation at present at our command, we are unable to discover any fundamental difference between the protoplasm present in animal cells and that in plant cells, or unicellular organisms. The uniformity is of necessity only apparent, . . . for the vital processes occur in each organism in a manner peculiar to itself, . . . and since the protoplasm is the chief site of the individual vital processes, these differences must be due to differences in the fundamental substance, that is to say, the protoplasm." Consequently we must accept the theory that protoplasm of different organisms differs in its "material, composition and structure: important differences which are due, apparently, to variations in molecular structure."

Notwithstanding the sameness and uniformity in the appearance of the protoplasm, the cell itself, of which the protoplasm forms a more or less important part, when regarded as a whole, may assume a great variation in appearance. This want of uniformity, or irregularity, is partially accounted for by the variations in external structure, but it chiefly arises from the fact that sometimes one substance and sometimes another substance is stored up in the protoplasm in such quantities as to be distinguishable from it, and at times so much so, that were such bodies to be eliminated from the protoplasmic mass, their absence would reveal a series of small vacua, between which the protoplasmic groundwork of the cell would be visible, having the appearance of a network. This must not be confused with that net-like structure which is, in the opinion of some biologists, inherent in the protoplasm itself.

(10) "The Cell." See ante.

Van Beneden has proposed these adventitious elements should be called *Deutoplasm*, while *Paraplasm* is the descriptive term suggested for them by Kupffer <sup>(11)</sup>. Whatever advantages may recommend these descriptive terms, considering that the idea of an albuminous substance is always conveyed by the word "*plasm*," it has been regarded as safer not to adopt them, but to class these adventitious elements as *intraplasmic products* and *adventitious cell contents*. Otherwise to designate them according to their functional attributes, *reserve material*, and secretions; or to specify them as *yolk granules*, *fat globules*, *starch granules*, and *pigment granules*.

In considering the development of the cell these play important parts, and the difference between these elements and the protoplasm in which they find location is much the same as that existing between the organs of which our bodies are composed and those substances which, primarily, are taken up as food by the animal body, to be later on circulated in a liquid form through all organs. The former are termed, on account of being less dependent on the condition of nourishment of the body for the time being, and less subject to the variation, *tissue substances*, the latter circulating substances; in other words, *protoplasmic* or *tissue material*, while the adventitious elements are *circulatory substances*. It will be easier understood from this that the cell is constituted of two parts or divisions: the protoplasmic portion, wherein the adventitious elements, some of which may be unknown to us on account of our inability to differentiate them, find place, and the nuclear section, which of itself contains a nucleus.

In the *Amœba* we have a good example of a cell which is constituted of a mass of naked protoplasm; likewise the *Mycetozoa* and *Reticularia* offer very useful media for the study of cell-structure, being unicellular organisms. From their appearance it was supposed these were constituted with a cellular membrane. Taking the *Amœba* as an example, we find it a small mass of protoplasm which extends itself into foot-like processes, or pseudopodia; the body is not separated from the surrounding medium by any thin coating or covering, consequently it is termed a *naked body*; the only differentiation being, that the superficial layer of the protoplasm ectoplasm which may be regarded as a condensation of the hyoplasm, and, consequently, as free from granules—constitutes this exterior zone, thereby giving the appearance of an outer covering, discriminated by the term *ectosarc* to distinguish it from the darker mass, or *indoplasm*, which it surrounds, called *endosarc*, and in which the

(11) C. Kupffer. "Ueber differenzirung der Protoplasma an den Zellen thierischer Gewebe." Schriften des naturwissenschaftlichen Vereins für Schleswig-Holstein. Bd. I., p. 229. Heft. 3, 1875.

nucleus is embedded. Similar in appearance, only smaller, are the white blood and lymph corpuscles of the vertebrates. Protoplasm, then, represents the essentially active element of the cell, and its properties are consequently the attributes of life, and can therefore be rapidly distributed; it possesses the power of absorbing or secreting oxygen—the *pubulum vitæ*,—and in exchange giving off carbonic acid; it is also the seat of a kind of true pulsation. In the activity of eliminating the carbonic acid gas, other substances or waste

products are given off in company, and, naturally, new elements are introduced into the mass and absorbed, setting up the process of nutrition. If the elements so introduced are in excess of those discharged we have the phenomenon of growth; but if, on the contrary, the elements given off are in excess of those introduced or absorbed, we have diminution in proportion as the excess is smaller or greater, and which, if carried on in continuity, results in dissolution—that is, the death of the organism.

(To be continued.)

## COLORATION AND VARIATION OF BRITISH EXTRA-MARINE MOLLUSCA.

BY ARTHUR E. BOYCOTT.

(Continued from page 258.)

IT has been said that mollusca have to contend against many animal enemies in the sea; they have also to withstand that physical agent, the wave-wash, which is constantly striving to batter them in pieces. A. R. Hunt<sup>(1)</sup> has made some most interesting observations on this subject, and has shown how species with a strong development of the lip, or of sculpture in the form of spines, thus gain a broad base for a sandy bottom, which helps them to resist their special danger, viz., the alternate swing of waves on the bottom. Experimentally, in a tank, it appears that such species as *Murex monodon* (Australia), *Aporrhais pes-pellicani* (Torbay), *Strombus tricornis* (Red Sea), etc., while very hard to overturn by wave-effects from their natural attitude of rest with the mouth downwards, are, when once upset, very easily turned right again by the alternate swinging of the water at its bottom in shallow depths. Even in comparatively deep water (fifteen to forty-one fathoms) shells may be damaged considerably; a specimen of *Trochus granulatus* from Torbay, in fifteen fathoms, had repaired breakages nine times, and of a miscellaneous parcel of shells from the Channel fishing-grounds, sixty-eight per cent. showed signs of damage caused by some agent external to themselves. This inimical wave-wash accounts at once for one of the two striking characteristics in which marine differ from freshwater mollusca. The thickness and solidity which is so striking in most sea shells, prevents, or tends to prevent, fracture on being dashed about among stones and rocks by the waves.

It seems then that marine mollusca lead a hard life; but when we come to our quiet<sup>(2)</sup> streams and

ponds, we find a very different state of things. The population is more scanty, at any rate as far as large predacious animals are concerned, and the shells of the characteristic genera are thin and monochromatic. Charles Darwin long ago remarked on the fact that competition was and has been less severe in fresh water<sup>(3)</sup>. The cod and other large fish are replaced chiefly by the trout, roach, etc., which chiefly affect localities where *Limnaea* is not so numerous as in the ponds they chiefly inhabit, where the fish are not numerous. Roach are reputed to eat snails' eggs<sup>(4)</sup>; and there is no doubt that trout feed readily on snails. *L. peregra* var. *burnetti* was first taken in a trout's stomach in Loch Skene, Dumfriesshire<sup>(5)</sup>, and has been found by Walker in a similar situation in the Gillaroo trout (*Salmo stomachicus*), in a lake in Co. Tipperary<sup>(6)</sup>. W. Jeffery has recorded finding about 350 shells in the stomach of a large eel, in Sussex, principally *Valvata piscinalis*, but also *Planorbis complanatus* and *Bithinia tentaculata*. Mr. H. C. Moore tells me that he has frequently found shells in the stomachs of trout caught in the Aymestrey waters of the Lugg, in the north of Herefordshire, and has shown me several *Limnaea peregra* thus procured. He was good enough to collect for me in the end of May last year (1896) all the shells from the stomachs of twelve trout from the locality mentioned. They consisted of *Valvata piscinalis*, thirty-three; *Ancylus*

<sup>(3)</sup> "Descent," ed. vi. p. 83.

<sup>(4)</sup> F. Buckland, "Curiosities of Natural History," i. (1890), p. 255.

<sup>(5)</sup> E. Forbes and S. Hanley, *Hist. Brit. Moll.*, iv. (1853), p. 173.

<sup>(1)</sup> "On the Formation of Ripplemark," *Proc. Roy. Soc.*, xxxiv. (1882), p. 1.

<sup>(2)</sup> J. Madison (*Journ. Conch.*, v. p. 261) thinks that the shape, strength, etc., of *Limnaea peregra* var. *burnetti* saves it from being broken when the stones on which it sits are rolled about by the waves.

<sup>(6)</sup> J. G. Jeffreys, B. C. v. (1869), *Suppl.*, p. 153. H. G. Seeley considers that the muscular thickenings of the walls of the stomach, characteristic of this species ("local race"), have arisen from its diet of *Limnaea*, *Ancylus*, etc. "Freshwater Fishes of Europe" (1886), p. 280. E. Collier has recently recorded *Limnaea peregra-lacustris* and *Pisidium pusillum* from a trout's stomach from an Irish lough. *J. C.*, viii. (1897), p. 331.

*fluvialtilis*, four; *Planorbis albus*, one (7), and he tells me that "the May-fly was in season, and the trout were well gorged with May-fly." As the bodies in many of the shells were comparatively quite fresh when I examined them the day after capture, it is clear that the trout really like this food, and will eat mollusca even when such tempting viands as the May-fly are present in abundance. The fact that salmon take practically no food during their residence in fresh water is also in favour of mollusca. The lobster, which will break open even a whelk's shell (8), is replaced by *Astacus*, at once less numerous and less powerful; it will, however, eat molluscs, shells and all (9). Birds no doubt destroy a certain number. Ducks seem, in fact, to thoroughly clear out any pond they go to frequently, and it is a matter of congratulation that there are still some ponds left undried which have not been spoilt by ducks (10). Small fishes, such as gold-fish and sticklebacks, are known to destroy some molluscs, but as it seems to take a gold-fish a day or so (11) to extract the snail, the ravages they commit are probably not very extensive. Rats are well-known to have a partiality for mussels (12), and frogs must be included among their enemies. *Hydrophilus piceus* and *Dytiscus marginalis* eat snails, and the latter is said to have a nice taste in them (13), and leeches are, perhaps, very destructive (14). It has been recorded that bats will eat *Paludina* (15), *Planorbis* and *Anodon* (16). Adding to all this the ravages of parasites, the number of freshwater mollusca destroyed by all their enemies must be far less, both absolutely and relatively, than in the sea.

With the advantages which have been pointed out surrounding a freshwater life, why have not more marine mollusca taken advantage of them? It is not that marine organisms cannot fairly readily stand a change, especially if gradual, from salt water to fresh. This was shown long ago experimentally by F. S. Beudant (17), who found that marine mollusca could, by gradually changing the water, become accustomed to a freshwater life, and *vice versa*; though a sudden change is attended with fatal results. From the table given

by Semper we learn that after 151 days in sea-water eighty-five per cent of the 391 specimens of fifteen marine species were alive. In half sea half fresh water, seventy-four per cent. were alive. After 278 days in sea-water sixty-one per cent. survived, and after half-and-half for fifteen days, and then 273 days in quite fresh water, forty-two per cent. lived. The common mussel (*Mytilus edulis*) showed the greatest power of resistance, 100 per cent. surviving in each of the four cases. This is interesting in view of its connection with *Dreissena* (18), pointed out elsewhere, and the existence of freshwater *Mytilus*. It is also noticeable that, as might have been expected, shore species bear the change better than deep-sea ones. The real explanation is probably threefold: (1) because free-swimming larvae get swept out to sea again, for undoubtedly Sollas' objection to direct migration does carry some weight with it; (2) because fresh water is often somewhat impure and contaminated with sewage, etc.; and (3) because the climatic conditions in fresh water are so much more severe than in the sea. The inhabitants of our streams and ponds, owing to the small volume of the waters, are exposed to great variations of temperature, and are liable—as has been especially noticeable during the last few years, in this district at any rate—to complete desiccation. In this sense freshwater animals lead a far more dangerous life than marine ones, which live in a fairly constant volume of water of a fairly constant temperature. This must, however, be carefully distinguished from a struggle for existence with other animals. Such hardships do not normally lead to the development of any kind of cryptic, epigamic, or sematic coloration. This is produced by the interrelation of organism with organism, not of organism with inorganic nature (19).

Certain forms of *Limnaea*, noticeably the very abundant *L. peregrina* (20), show an extraordinarily wide range in variation. This, perhaps, is a further indication of the comparative ease of the conditions under which they live, as mentioned under *Tachea* above. It is noticeable, especially as the immediate origin of freshwater pulmonates is so obscure, that the typical freshwater genera, *Limnaea*, *Physa*, *Planorbis*, are of world-wide distribution.

Now since *Limnaea* and other shells partake in no way of the characters of marine shells, and since their life is much easier and more peaceful, it is not unreasonable to regard their thin unicolorous covering as an example of shell degenera-

(7) This is about the proportion in which the species occur in the river, no especial liking for *V. piscinalis* is to be implied.

(8) J. G. Jeffreys, B. C., l. (1902), p. 113.

(9) F. H. Huxley, "Crayfish" (1881), p. 9.

(10) I know of one pond where a form like *Limnaea peregrina auriculata acuta* occurs in great abundance with *Planorbis glaber*, despite the fact that the pond is habitually frequented by numerous ducks.

(11) J. G. Jeffreys, B. C., l. (1902), p. 113.

(12) L. E. Adams, *op. cit.*, p. 161; J. F. Whiteaves, *Moll. Oxford*, p. 14.

(13) J. W. Williams, *Science Gossip*, 1869, p. 286.

(14) J. F. Whiteaves, *op. cit.*, p. 17.

(15) In Yorkshire rats eat *P. vitipara*. W. Nelson and J. W. Taylor, *Trans. Yorks. Nat. Union*, part 5 (1886), p. 26.

(16) "Naturalists' Journal," v. (1866), pp. 78, 79.

(17) "Journal de Physique," lxxviii (1816), p. 68. K. Semper, "Animal Life" (1890), 139. H. de Vaugny, "Experimental Evolution" (1890), p. 15.

(18) It has recently been stated that *Dreissena* is not allied to the Mytilidae: E. Bernard, *Bull. Soc. Geol. France* (3) xxv, p. 559 in "Natural Science," xii (1898) p. 4.

(19) Adventitious protection may be said often to be inorganic in character.

(20) I use this name in a loose and inclusive sense as covering both palmiform, intermediate and articulatiform forms.

tion. The circumstances are such under which degeneration might be expected, and the results are such as one would expect to accrue from degeneration. This I understand to be the explanation of this form of shell; assuming, that is, that the marine species from which they are derived had a coloured ornamented shell. This is rendered not unlikely, assuming again that they are derived from species having any considerable shell at all <sup>(21)</sup>, from a consideration of recent marine mollusca, and is further supported to some extent by palaeontological evidence <sup>(22)</sup>. If, however, it is held that their ancestors in the sea were uncoloured and unornamented like themselves, their type is an archaic one. This is the construction which Darwin appears to put upon the facts, on the ground that the absence of competition would lead to a permanence of form and no great development of fresh forms; he, however, says very little about the group <sup>(23)</sup>.

It has recently struck me that the early pigmentation in *Limnaea stagnalis* looks remarkably like the remains (or the beginning) of a band in the region of the periphery; but the indications are not as definite as they might be, to indicate a hypothetical banded ancestry.

There are some grounds, as mentioned above, for supposing that *Limnaea* and its allies have been derived immediately from terrestrial forms. In this case their ancestors may have been uncoloured too, for is impossible to trace coloration through the profound change from an aquatic to a terrestrial habit. The Pectinibranchiate forms, such as *Bithinia*, have almost certainly not gone through any terrestrial line of descent, being derived more or less directly from marine forms; so that here, at any rate, there is a case in point. W. J. Sollas <sup>(24)</sup> is of opinion that this thin shell has arisen by natural selection, and is correlated with the lower specific gravity of fresh water; the snails are thus enabled to move about more easily. Considering the very complete hydrostatic apparatus possessed and used by the Limnaeidae in their lung, with which they can alter their specific gravity very readily and accurately according to their requirements, this does not seem a very satisfactory explanation, though it possibly has some weight, especially in the non-pulmonate genera, where, however, the reduction in thickness is not nearly so great.

(To be continued.)

## NOTES ON PLANT LIFE.

By P. Q. KEEGAN, LL.D.

### AUTUMN TINTS.

**T**URNING over a volume of Longfellow's Poems, I found the following passage descriptive of autumn in America: "The gentle wind, a sweet and passionate wooer, Kisses the blushing leaf, and stirs up life Within the solemn woods of ash deep-crimsoned."

Here we have the autumnal foliage of the ash tree depicted as being coloured a deep crimson. The point may seem a trivial one, but in reality it is very important. The first query is, does the poet here allude to the common ash (*Fraxinus excelsior*) of our woods and groves? Likely not, for it is known that our tree is represented in North America by a closely allied species. Wherefore should its leaves be deep-crimsoned in the Fall, while ours at that season is only lemon-yellow, passing to a dark muddy brown? Is the former nearer relatively to its northern limit of growth than the latter? We have an analogous case in the late leafage of the common privet (*Ligustrum vulgare*) of our hedges, which exhibits a dark crimson or purplish ash shade. I have chemically examined this phenomenon, and

<sup>(21)</sup> Some authorities think that the *Limnaea* ancestor is to be found in the more or less shell-less groups.

<sup>(22)</sup> Some geologists of whom I have enquired have disagreed with me here. It may be that it has been the custom in works on the subject to figure only the more ornamented and decorative species.

<sup>(23)</sup> "Descent," ed. vi. p. 83.

can testify that the "chromogen" of this colouring matter is not identical or even analogous with the corresponding pigments of the oak, sycamore or Norway maple leaves. Similarly, I have studied the "chromogen" of the mystic ash, and have found that it is identical apparently with that of the privet; but while it is not developed into a visible pigment in the former case with us, in America the influence of the environment has effected the impressive change in the closely allied species to which the poet in the foregoing passage most probably alludes.

### DISSEMINATING YEASTS.

In the January number of this journal (*ante* p. 222) "the part played by living organisms in disseminating the yeasts to which the fermentation of fruits, etc., is due" is considered; and in this connection it is profitable to recall a paper in the "Annales des Sciences Naturelles," by M. Boutroux, published some ten years ago or more, wherein he remarks: "The species of yeast which are so abundant in fermenting wine arise from the germs which were clinging to the grape prior to the mashing, and brought there by insects, and they predominate in the fruit worts (must) only by their very great power of proliferation on these media." He also

<sup>(24)</sup> Sci. Trans. Roy. Dublin Soc. (2) lii. p. 103.

says, "the presence of yeast germs in flowers is a normal fact at all seasons, and they are capable of making sherry must enter into alcoholic fermentation. It is very likely that the nectaries of flowers furnish a medium suited to the multiplication of the yeast. There is much more yeast on the bodies of insects, especially those which frequent nectariferous flowers." With regard to fruits, he says that "whereas certain green fruits have yeast germs normally, others are deprived of them, and they are rare on ripe, intact fruits." I may add that it is known that after fecundation, in proportion as the fruit is developed, that most of the sugar which is accumulated near the ovary passes into the tissues of the fruit and the seeds, and at the same time it becomes completely assimilable under the influence of a soluble ferment; even the liquid nectar is reabsorbed. Whether this most useful invert-ferment has been derived in some way from the yeast germs conveyed to the flower by insects is a point which I leave to the consideration of teleological botanists of the Darwinian school. From the fact that one is an organized ferment and the other an unorganized one, not to mention that the former is rarely found on ripe intact fruits, it seems to follow that they have got nothing to do with each other.

In a recent number of SCIENCE-GOSSIP (*ante* p. 183), there has been a sort of discussion as to whether albanism in plants is due to an abnormal or diseased state of the chlorophyll. I feel rather diffident about putting in a word on the subject. It does seem rather peculiar, however, that a white flowered variety of *Epilobium hirsutum* (*ante* p. 183), supposed to prove disease, should nevertheless have been preserved constant, and have survived for no less than 174 years. What albanism in blue or red flowers has got to do with chlorophyll, directly or even indirectly, is more than any petty dabbler in plant chemistry can precisely indicate. Albanism in yellow, orange, or brick-red corollas stands on a different footing altogether, inasmuch as some, but not all of the chromoplasts which colour these flowers seem to be directly derived from chloroplasts, *i.e.* chlorophyll granules. Even here there is not much certainty. "In the actual state (year 1888) of science," says M. Courchet, "it is impossible to decide if the pigments of the leucites (chromoplasts) are derived directly from chlorophyll, or if they are formed at the expense of substances already elaborated."

#### CAUSE OF VARIEGATED LEAVES

With regard to variegated leaves, the principal fact about them seems to be that the white portion of a leaf does not decompose carbonic acid, but rather gives it off, and, like a para-

site, draws the whole of its sustenance from the green portion of the organ. We learn also that the white portion has five and a-half per cent more water than the green portion, is richer in nitrogen, phosphoric acid, potash, and ash constituents; but is poorer in fatty matter, and has but little lime. Do these facts indicate the presence of disease in that part of a leaf which suffers under deprivation of chlorophyll? With regard to chlorophyll itself existing in a sickly state, I possess one note by M. Mesnard. He states: "In autumn the chlorophyll undergoes a kind of oily transformation very comparable to the fatty degeneration which occurs sometimes in animal tissues." Fatty degeneration is undoubtedly a morbid condition, and if this process actually occurred in the white portions of a variegated leaf we should be able to detect it by its higher percentage of fat, whereas in point of fact these portions are, as aforesaid, comparatively poor in that substance. Moreover, considered in a general way, it is not altogether clear that partial albanism in leaves is necessarily a symptom of an hereditary weakness in certain species. It is quite possible and is generally admitted that a tree may sometimes have too many leaves, as the leaf area may be by no means always proportional to the supply of food-materials coming from the soil. Hence, if this be the case, and especially if the leaf be evergreen, as in ivy, holly, etc., there is nothing lost apparently by the limitation by partial albanism of the total area of the foliar organs which contain chlorophyll, and thuswise minister to the important function of assimilation.

*Patterdale, Westmoreland.*

TWO AMERICAN NATURALISTS. — Lovers of natural science in America cannot be accused of neglecting their dead. A "Commemoration Meeting" was specially held by resolution of the Academy of Natural Sciences at Philadelphia, on December 31st last, to commemorate the services to science of Dr. Harrison Allen and Dr. George H. Horn. Papers were read by naturalists, eulogising the work of their departed leaders. The report of them occupies thirty-three pages of the "Proceedings of the Academy" just to hand. Harrison Allen was born in Philadelphia in 1841; he died on November 14th, 1897, whilst hard at work. He was intended for the medical profession, studied dentistry, and served for three years, from 1862, as an army surgeon in the civil war. He then became a successful and painstaking Professor of Zoology in the University of Pennsylvania, leaving behind him a fine record and much work achieved. He was also in the medical profession, and lived to become one of the leading coleopterists of the century. It is a curious coincidence in these two men's lives, that they were born in the same city within a year; educated in the same school; both became medical men in the army; both Professors of the same University and of the same subjects; and both died suddenly in the same month.

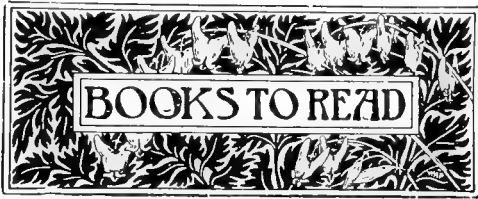

NOTICES BY JOHN T. CARRINGTON.

*Elementary Physics.* By JOHN G. KERR, M.A. 140 pp. crown 8vo., illustrated with 54 figures. (London, Glasgow and Dublin: Blackie and Son, Limited, 1898.) 1s. 6d.

This is one of a new series of handbooks issued with the object of setting forth in order the essentials of a laboratory and class-room course of Science suited to the capabilities of pupils commencing the studies to which the books are applied. Each handbook will contain the instruction for one year's work; the one before us being for the first year. They are divided into two sections, the first being for practical work and the second for class-room or theoretical work. They are designed to meet the requirements of the Education Department, and also for encouraging accuracy of observation, directness of method, fertility of resource, and self-reliance. These handbooks will be valuable alike for teachers and home workers.

*Storm and Sunshine in the Dales.* By P. H. LOCKWOOD. 94 pp. crown 8vo, illustrated with 8 plates. (London: Elliott Stock, 1898.) 3s.

This little work belongs to the category of country lore, and contains in addition some references to the habits of plants and animals inhabiting the beautiful country around Sedbergh, in Yorkshire, the locality where the author writes. The book is prettily illustrated from photographs by the author, and it will doubtless find some readers beyond the circle of his own acquaintances.

*The Botanical Laboratory.* Vol. i. No. 3, 160 pp. large 8vo, illustrated with 19 plates. (Philadelphia University, 1897.)

This is one of the publications of the University of Pennsylvania, being contributions from the botanical laboratory. The part contains three valuable papers, each being by a lady. The first is "A Chemico-Physiological Study of *Spirogyra nitida*," by Mary E. Pennington, Ph.D.; "On the Structure and Pollination of the Flowers of *Eupatorium*" is by Laura B. Cross, Ph.D.; and "Life-History of *Amphicarpaea monoica*" is by Adeline F. Schively, Ph.D. The latter paper is illustrated by eighteen plates.

*Experimental Farms of Canada: Report for 1896.* Edited by WILLIAM SAUNDERS, LL.D., F.L.S. 474 pp. large 8vo, illustrated with many plates and drawings in the text. (Ottawa: S. E. Dawson, Queen's Printer, 1897.)

We have on previous occasions had the pleasure of referring to the admirable reports issued under the supervision of Professor Saunders, relating to the splendid work done at the experimental farms under his direction. These farms are distributed in various parts of the Dominion, with the object of supplying scientific information to the farmers of the various regions which they represent. The chief central farm is near Ottawa, and there are others in Nova Scotia, Manitoba, in the North-West Territories and in British Columbia.

We have only to turn over the pages of the work before us to discover how carefully and scientifically is prepared the information supplied. Neither political party in the Dominion appears to begrudge the grant of public money which is annually expended at the discretion of Professor Saunders. The subjects contained in this last report are very varied, and include, in addition to farm crops, remarks upon the culture of fruit-bearing trees and shrubs, and some garden flowers. The chemistry of the subject is elaborately dealt with. An interesting section of this report is that furnished by Mr. James Fletcher, LL.D., F.L.S., etc., entomologist and botanist to the establishment.

*Phylogeny and Taxonomy of Angiosperms.* By CHARLES E. BESSEY, Ph.D. 34 pp. small 4to.

This is a reprint from "The American Botanical Gazette" (vol. xxiv.), and is the presidential address of Dr. Bessey, Professor of Botany in the University of Nebraska, delivered before the Botanical Society of America, at Toronto, August, 1897. It is a carefully worked out dissertation which has evidently taken much time and research to compile. It will be found of importance to students of the phylogeny of plants, on account of Dr. Bessey's reputation as a botanist. The author illustrates his paper by some excellent diagrams.

*North American Lemnaceae.* By CHARLES HENRY THOMPSON. 22 pp. large 8vo, illustrated with 4 plates. (St. Louis, Mo.: at the Gardens, 1897.)

This very useful pamphlet forms a portion of the Ninth Annual Report of the Missouri Botanical Garden. It includes descriptions of about fifteen species of duckweeds. These are illustrated with beautifully executed drawings of the plants, and anatomical details to assist in identification.

*British Game Birds and Wild Fowl.* By BEVERLY R. MORRIS, M.D., revised by W. B. TEGETMIER, F.Z.S. Parts vii. viii. ix. and x., super royal 8vo, with coloured plates. (London: John C. Nimmo, 1897.) 2s. 6d. per part.

Part vii. commences the second volume. It completes the Snipes and commences the Geese, which are continued through Part viii. Part ix. contains the Swans, the Sheldrakes, the Shoveller, and commences the Ducks, which are concluded in Part x., where are also the Teals and Widgeon. As we stated in a previous notice, when complete the work may be useful to sportsmen, but from the ornithologist's point of view it is greatly to be regretted that this new edition has been so inefficiently revised, as a good deal of recent knowledge in connection with this popular group of birds appears to have been omitted.

*Glass Blowing and Working for Amateurs.* By THOMAS BOLAS, F.C.S., F.I.C. 212 pp. 8vo, with coloured plate and 103 figures. (London: Daborn and Ward, Limited, 1898.) 2s. net.

To those who are in search of a hobby which can be worked at home without too much expense, or desire to make for themselves some of the more simple glass apparatus used in scientific work, this work is recommended. It is based upon a series of lectures, and the demonstrations to illustrate them, given under the auspices of the Technical Education Committee of the Middlesex County Council. The author has aimed at making the book a laboratory, workshop and household guide to glass-working with the blowpipe. The instructions given will be useful to many students who find the obtaining or alteration of glass apparatus a matter of some difficulty.

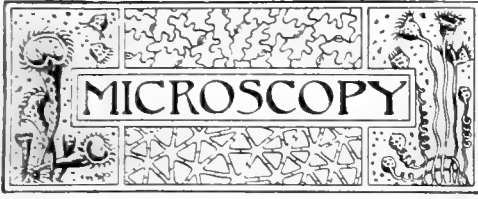

CONDUCTED BY J. H. COOKE, F.L.S., F.G.S.

To whom Notes, Articles and material relating to *Microscopy*, and intended for SCIENCE-GOSSIP, are, in the first instance, to be sent, addressed "J. H. Cooke, Thorndale, Lincoln."

**AN EFFECTIVE BACTERICIDE.**—A new German antiseptic called "protargol" is a compound of silver and protein. A one-per-cent solution is reported to destroy the bacteria of anthrax and enteric fever.

**MICRO-PHOTOGRAPHY.**—At a recent meeting of the Royal Society Professor Roberts - Austen exhibited an apparatus for micro-photography which has been brought to such a degree of perfection that by its means the condition in which carbon exists in steel is clearly shown. He demonstrated that under a magnification of 1,000 diameters, steel may be seen to contain minute particles of true diamond.

**CULTURE MEDIUM FOR PROTOZOA.**—Scharfinger has succeeded in cultivating the mycetozone *Protozonas spirogyrate*, Borzi, pure and free of bacteria, in the following medium: about 30 grammes of hay are suspended in 1 litre of water, 1 to 1.5 grammes powdered calcium hydrate added, the whole well shaken and the mixture heated in the oven for twenty-four to thirty-six hours. It is then filtered, the calcium precipitated in the filtrate by phosphoric acid. The filtrate is mixed with equal parts bouillon, alkalinized with soda, and employed as usual with the addition of 1 to 1.5 of agar.

**PHOSPHORESCENCE OF THE LIMANS.**—The limans in the neighbourhood of Odessa, that is the salt water lakes on the shore which have already lost their connection with the sea, are sometimes seen to emit a phosphorescent light. As the *Noctiluca miliaris*, which renders the water of the Black Sea phosphorescent, does not inhabit the limans, their water was carefully investigated by M. Zabelotuyi, who found that all the light is due to an infusorium, *Glenodinium*, allied to *G. cinctum*, from the Peridinidae. It appears that it is the protoplasm of the little animal which emits the light.

**MYCORRHIZA OF ROOTS.**—M. J. N. Jauce has been conducting investigations on some of the indigenous plants of Java, and he has found that out of seventy-five species examined, sixty-nine are infested with an endophytic mycorrhiza, the filaments of which enter the tissue by perforating the external walls of an epidermal cell. The fungus forms sporangioles, varying between 2.5 and 2.3  $\mu$  in diameter, within the cells of the internal layers of the infected tissue. The connection of the parasite with the host is one of true symbiosis, the fungus furnishing to the host plant nitrogenous food materials obtained by assimilating the free nitrogen of the atmosphere, receiving in return protection as well as food material in the form of carbo-hydrates. The mycorrhiza may be regarded as a facultative anaerobe which penetrates the living tissue for the purpose of avoiding oxygen.

**INFLUENCE OF NUTRIENT MEDIA ON THE DEVELOPMENT OF FUNGI.**—Messrs. Ray, Schostakowitsch and Richards have recently been conducting experiments on this subject, the results of which are of considerable interest to microbotanists. J. Ray's researches were confined chiefly to *Sterigmatocystis alba*, and he found that while all of its specific characters were liable to vary, its generic characters were fairly constant. The size of its spores remained constant under all conditions. W. Schostakowitsch found that the temperature and nature of the nutrient fluid greatly affected *Mucor proliferus*. The spores varied both in size and shape. Mr. H. M. Richards experimented with *Aspergillus niger*, *Penicillium glaucum* and *Botrytis cinera*, and he found that the growth of these fungi was markedly affected by the character, chemical composition and even the colour of the nutrient medium.

**FOOD SUPPLY OF FISH.**—Observers are beginning to trace the connection between the presence of microscopical organisms and the abundance of fish in our lakes, and valuable comparisons have been made between the stomach and intestinal contents of fishes and the organisms found in the water where the catches were made. Mr. G. C. Whipple has, says "Science," given this subject considerable attention, and as it is of considerable importance, it should be vigorously pursued by our fish commissions. To be of the greatest value it should extend well over the country, and include lakes and ponds sufficiently different in character to enable one to determine the laws governing the nature and distribution of the plankton in various places and under various conditions. Here is new ground for the microscopists of SCIENCE-GOSSIP. Work on the waters of the Broads, the Lake District and Wales, carried on systematically, would furnish valuable data for the understanding of this subject.

**LATENT LIFE IN SEEDS AND MICROBES.**—Much of the problem of life is intermingled with that of the vitality of seeds, which is still a matter of difference among biologists. Some hold that there is simply a slowing down of life in the dormant seed, imperceptible change and respiration continuing to take place; while others believe that the vital machinery is brought to an absolute rest for a time, to be started again when external conditions become favourable. In a recent Royal Society paper, Messrs. Horace T. Brown and F. Escombe pointed out that the former hypothesis overlooks the remarkable evidence available. The late G. J. Romanes kept seeds fifteen months in a vacuum of a millionth of an atmosphere, and also in such a vacuum followed by an atmosphere of carbon monoxide, carbon dioxide, hydrogen sulphide, ether, chloroform, and other gases and vapours, and such treatment had little effect upon subsequent germination. There could have been no respiration of ordinary kind. In 1884, Pictet and C. de Candolle exposed microbes four days to a temperature of 100 below zero C. without effect, and the authors have since been enabled, by Professor Dewar, to keep seeds at 183° to 192° below zero for 110 hours, still with no perceptible influence on germination. Chemical action being annihilated at 100 below zero, molecular interchange in the protoplasm itself is disproved. This state of complete chemical inertness in living protoplasm is likened by C. de Candolle to that of an explosive mixture whose components can remain indefinitely in contact without combining until a certain temperature is reached.



A MYXOMYCETOUS PARASITE.—M. E. Roze has detected *Pseudo-commis vitis*, a myxomycete, in the hypodermal cells of the tubers, as well as in the eaves, of diseased potatoes. It occurs in the form of plasmodes and of cysts, and attacks both the cell-nucleus and the starch grains. According to the author, it occurs very commonly in garden and greenhouse plants. The black and brown spots, which indicate the malady known to gardeners as "burning," are due to the attacks of this parasite. It is often overlooked owing to its very rudimentary structure, consisting of a plasmode-like mucus, which becomes encysted in certain conditions. As long as the plasmode is in a living condition it is able to escape, under favourable conditions, and infect other vegetable tissues.

THE SPORULAR DEVELOPMENT OF AMOEBA VILLOSA.—Mr. J. C. Smith gives an interesting account in the "American Microscopical Journal" of his observations on the sporular development of *Amoeba villosa*. He obtained his specimens by scraping the surfaces of some decayed leaves from a park pond; and he conducted his observations with a  $\frac{1}{4}$ -inch objective. One of the specimens was seen to contain a number of nuclear bodies that varied in size from  $\frac{1}{8750}$  to  $\frac{1}{8000}$ -inch, which, after a short time, were ejected from the *Amoeba* with considerable force. The nuclear bodies shortly afterwards developed flagelli equalling in length from four to five of the bodies' diameters, and became exceedingly active. From this point the writer describes in some detail the full life-history of these bodies, in the course of which he shows how the *A. villosa* are once more evolved. To make this history of the sporular development of the *A. villosa* (and by inference all *Amoeba*) complete there is only one essential requisite, and that is to trace the origin of the nuclear-looking bodies to the nucleus.

MICROSCOPIC SECTIONS OF OOLITIC GRAINS.—In reply to T. W. P. (Brighton), we would recommend the following method for sectioning any fragmental substances as being, in our experience, both simple and effective. Further details may be obtained from Dr. Wallich's article in "The Annals and Magazine of Natural History," vol. viii. p. 58; from Professor Cole's "Aids to Practical Geology"; or from an article by Mr. F. Chapman which appeared in "Scientific News," vol. i., p. 452. A small glass slip or square cut from plate glass is laid upon a metal plate over a spirit-lamp. A drop of nearly dried balsam is softened upon this by heat, and a plate of mica is laid on it, becoming thus cemented to the glass. The small objects, of which sections are to be prepared, are then embedded in further balsam upon the mica surface and arranged in any suitable position. When this balsam is cold and firm the glass is used as a handle, by which the objects can be held during grinding. A flat surface is then given to them as they lie in the balsam by rubbing on a hone. Lightly heat the glass, and as soon as the lower film of balsam between the mica and the glass softens, lift up the mica with a pair of forceps and turn it over on to an ordinary glass slip on which a little balsam has been heating. The ground surface of the objects is now downwards, and when cold the mica may be flaked off the upper surface. Using the new slip as a handle, the newly exposed side may be ground down to the required degree of thinness.

## NEW TYPE OF MICROSCOPE.

IN consequence of the rapidly increasing necessity for microscopes of an inexpensive character, Messrs. Ross, Limited, of 111, New Bond Street, London, have produced a remarkably useful as well as cheap instrument, of which we give an illustration.

In designing this special type of microscope, the firm has had in view its increased use in connection with research in agricultural and horticultural, as well as other sciences. It is intended to be further applied to the textile trades, and examination of produce and raw materials. The pattern of this instrument has been arranged in view of the fact that many of its future users require the simplest form; and one free from unnecessary complications. At the same time stability and steadiness are absolutely necessary for its successful use. This has been achieved. Remembering that the class who are likely to purchase such an instrument as this will require it for use in their professional or trade occupations, Messrs. Ross have provided one which can be sold at so low a price as three guineas, including limb, choice of  $1\frac{1}{2}$ -inch,

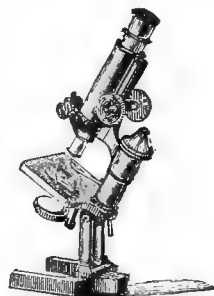

$1\frac{1}{2}$ -inch or  $\frac{1}{2}$ -inch objective, eye-piece, mirror, rack adjustment, sub-stage plate, and glass dish for liquids. If the purchaser finds that he requires additional parts, these can be obtained either at once or later, as required. They include objectives, fine adjustment, iris diaphragm, fitting stage, condensing lens fitting stage, double nose-piece, etc. A fitting beneath the stage of the instrument in its simplest form carries a plate with diaphragm apertures. These are to modify the light, and as opaque objects, such as seeds and fibres, will form a large proportion of those to be examined, this sub-stage plate has a space between the perforations which, when brought into position, provides a dark ground by preventing the passage of light from underneath. This fitting is removable, to allow the use of an iris diaphragm if desired.

Altogether, this instrument, which is named the "Industrial Microscope," is produced with that excellence for which Messrs. Ross, Limited, are well known.

J. T. C.





CONDUCTED BY FRANK C. DENNETT.

		Rises.		Sets.		Position at Noon.	
		h. m.		h. m.		R.A. Dec.	
Sun	3 ...	6.45 a.m.	5.41 p.m.	22.57	6° 42' S.		
	13 ...	6.20	6.0	23.34	2° 48'		
	23 ...	5.57	6.17	0.11	1° 9' N.		

		Rises.		Sets.		Position at Noon.	
		h. m.		h. m.		R.A. Dec.	
Moon	3 ...	0.14 p.m.	8.42 p.m.	4.24 a.m.	10 16 19		
	13 ...	0.0 a.m.	3.59 a.m.	7.52	20 16 19		
	23 ...	5.50	0.51 p.m.	8.10 p.m.	1 3 23		

		Souths.		Semi		Position at Noon.	
		h. m.		Diameter.		R.A. Dec.	
Mercury	3 ...	11.33 a.m.	2° 5'	22.18	12° 53' S.		
	13 ...	0.1 p.m.	2° 5'	23.26	5° 36'		
	23 ...	0.33	2° 6'	0.37	3° 27' N.		
Venus	3 ...	0.28	4° 9'	23.14	6° 33' S.		
	13 ...	0.35	4° 9'	23.59	1° 32'		
	23 ...	0.41	5° 0'	0.45	3° 34' N.		
Mars	13 ...	10.22 a.m.	2° 2'	21.47	14° 37' S.		
Jupiter	3 ...	1.49	20° 1'	12.32	1° 47' S.		
	13 ...	1.6	20° 3'	12.28	1° 19'		
	23 ...	0.22	20° 4'	12.24	0° 48'		
Saturn	13 ...	5.20	7° 9'	16.44	20° 27' S.		
Uranus	13 ...	4.43	5° 8'	16.6	20° 42' S.		
Neptune	13 ...	5.51 p.m.	1° 3'	5.16	21° 43' N.		

MOON'S PHASES.

Full	Mar. 8 ...	9.29 a.m.	3rd Qr.	Mar. 15 ...	7.48 a.m.
New	22 ...	3.37	1st Qr.	30 ...	7.40

In apogee, March 1st, at 5.1 a.m., distant 251,200 miles; in perigee on 14th, at 2.9 p.m., distant 230,000 miles; and in apogee again on 29th, at 1.5 a.m., distant 251,300 miles.

CONJUNCTIONS OF PLANETS WITH THE MOON:

Mar. 10 ...	Jupiter	1 a.m.	planet	7° 4' N.
14 ...	Saturn†	0 noon	"	5° 18' N.
20 ...	Mars*	1 a.m.	"	4° 25' S.
23 ...	Mercury*	2	"	5° 56' S.
23 ...	Venus†	7	"	6° 38' S.

OCCULTATIONS AND NEAR APPROACH:

Mar. 14 ...	Star.	Magni- tude.	Dis- appears. h. m.	Angle from Vertex. h. m.	Re- appears. h. m.	Angle from Vertex.
14 ...	♌ Scorpiis	11	2.38 a.m.	111°	3.49 a.m.	305°
26 ...	♉ Tauri	4.2	9.24 p.m.	316°	...	Near approach.
31 ...	♊ Geminaorum	3.7	11.13 p.m.	78°	0.14 a.m.	237°

THE SUN still continues to show spots on his disc, though most of them are small. At 2 p.m. on 20th the sun enters Aries.

MERCURY is a morning star during the earlier part of the month, is in superior conjunction at 9 p.m. on 16th, and later becomes an evening star; but it is too close to the sun for successful observation.

VENUS is an evening star all the month, and is never very far from Mercury, being in conjunction with it at 2 p.m. on 26th, Venus being 1° 14' south.

MARS is a morning star, rising about fifty minutes before the sun on 31st.

JUPITER is at its best this month, coming into opposition at midnight on 25th, the planet being still near to ♍ Virginis. On the morning of 10th, from 1.29 until 3.14 only, the fourth Satellite will

be visible near the planet to north-east, I. being eclipsed and II. and III. in transit.

SATURN is a morning star, rising at 1.55 a.m. on 1st and at 11.52 p.m. on 31st, being situated in the southern part of Ophiuchus.

URANUS is a little south-east of β Scorpii, and rises a little more than half-an-hour before Saturn.

NEPTUNE is still visible all the evening, but is a poor object for small telescopes.

METEORS may be looked out for specially about 1st, 2nd and 4th.

RED STARS IN POSITION DURING MARCH:

	R.A. h. m.	Dec.	Magni- tude.
B 290 Canes Venat.	12.39	46° 6' N.	5.5
α Ursa Majoris	10.56	62° 27' N.	1.5
R Crateris	10.54	17° 38' S.	8
β Corvi	12.28	22° 41' S.	3
ν Ursa Majoris	11.12	33° 30' N.	4

Variable in colour, orange to red. Variable.

ZODIACAL light may be looked out for after sunset this month. On February 8th, at Sunbury, the writer saw its apex reaching almost up into Aries at 6.40 p.m.

"THE SECOND MOON OF THE EARTH" is announced by "Dr. George Waltemath, of Hamburg, its discoverer," who has been sending out a "Summons to Astronomers," as well as writing an article in "The Globe" of February 7th. The "discovery" is, however, only on paper, and the data from which calculations have been made appear to be very insufficient, whilst the calculations themselves are carried out to what is really a preposterous degree of pseudo-accuracy. As an instance of this, the mean daily motion is given as 3° 01' 43.9012". A transit of the body across the sun's disc is predicted for July 30th. Its distance is given as 640,000 miles, or two and two-thirds the distance of the moon. The diameter is put at 435 miles, but it is said usually to be invisible owing to the bad reflecting qualities of its surface.

THE Gold Medal of the Royal Astronomical Society is this year being given to Mr. W. F. Denning, of Bristol, in recognition of his numerous discoveries in meteoric and cometary astronomy, as well as for his valuable work in other branches of the science. It is doubtful if the honour has ever been bestowed on a more worthy recipient.

AMHERST COLLEGE, Mass., has had 18,000 dollars bequeathed to it for the purpose of purchasing the site and erecting a new observatory. The trustees have granted the money for a new telescope.

A REMARKABLE meteor was observed over a large area at 5.34 p.m. (Greenwich mean time) on January 21st. It was exceptionally coloured. Some called it blue, others green, others again gold. The writer described it as deep green. It was visible in the southern sky. Its altitude when west-south-west—it travelled westward, sinking towards the horizon—was about 30° as seen from Dalston. It is said, where the sky was clear, to have been brighter than the moon.

THE MINOR PLANETS.—One observed by M. Charlois, on August 25th, 1897, is really a re-discovery of No. 188, found by Peters in 1878.

THE Lalande Prize, in the gift of the Paris Academy of Sciences, has been awarded to Mr. Perrine, of the Lick Observatory, for his discoveries of comets.



THE Rev. George Henslow has been elected Professor of Botany to the Horticultural Society.

THE post of patron of the International Congress of Zoology, to be held at Cambridge next August, has been accepted by the Prince of Wales.

THE first discoverer of the cathode-rays, Professor Lenard, of Heidelberg, has received the 10,000 francs prize from the French Academy of Sciences.

THE German Association of Men of Science and Physicians will hold its annual meeting this year in Leipzig, under the presidency of Professor Waldeyer.

A DEPARTMENT for hydrophobia, similar to the Pasteur Institute in Paris, is to be added to the Institute for Infectious Diseases in Berlin, of which Robert Koch is Director.

WE greatly regret to hear of the death of our correspondent, Mr. A. H. Béchervaise, of Santa Cruz, whose last article in this magazine appeared in September last.

THE Bruce gold medal of the Astronomical Society of the Pacific Coast has been awarded to Professor Simon Newcomb, of Washington, D.C., for his distinguished services to astronomy.

WE regret to record the death of Professor Ernst Ludwig Taschenberg, known for his contributions to popular economic entomology, who died on January 20th, at the age of seventy-nine.

A MUSEUM of natural history is in course of formation at the Vatican. It is under the direction of the Marquis de Mauroy de Wassy, and at present consists more especially of geological and mineralogical collections.

THE Trustees of the British Museum have presented the Council of King's College, London, with a valuable series of fossils in aid of the collection of the Geological Laboratory in the Science and Engineering Faculty.

THE Biological Department of the New York University has selected the Bermudas as the place of an expedition. It will be under the superintendence of Dr. C. L. Bristol. A laboratory will be installed at Castle Harbour.

AS President of the International Congress of Zoology to be held at Cambridge, commencing on August 23rd next, Sir John Lubbock invites zoologists to attend, so as to make this, the fourth Congress, as useful and important as possible. The International Congress of Physiologists will be held at the same time and town.

THE municipality of the small town of Votis, in Hungary, has set up a municipal installation for acetylene gas lighting. The streets and squares are already lit with this gas, and many private houses are beginning to make use of the facilities provided by this advanced municipal body.

DR. EDUARD LINDEMANN, the scientific secretary of Pulkova Observatory, has died in his fifty-sixth year.

THE Vatican Observatory will be under the direction of Professor G. M. Searle, of Washington, who succeeds the late Father Denza.

DR. GILLOT and H. M. Leveillé are forming a French Botanical Association to take the place of the French Botanical Society which was dissolved in 1895.

MR. J. LUCHMAN has been appointed to the post of Government Botanist to the Colony of Victoria, which was vacant by the death of Baron Ferdinand von Müller.

DR. WALDEMAR VON SCHROEDER, Professor of Pharmacology in the University of Heidelberg, and the author of several works on physiological chemistry, has recently died.

DR. OSCAR STUMPE, best known for his investigations of the sun's motions, has died at the early age of thirty-seven. For the past six years he has been engaged on the Berlin Zone Star Catalogue.

AN expedition has set out from Tauris, in Persia, to the Lake Ourmiah, famous for its salt waters and for the number of its zoophytes. Professor Paladini, of Milan, is the director. He proposes to make an exact plan of the lake and its surrounding neighbourhood.

M. ARTHUR KAMMERMANN has passed away, in his thirty-sixth year, having been born in 1861. He was educated at the Zürich Polytechnic, and since 1881 has done much useful work, both astronomical and meteorological, at Geneva Observatory, Switzerland.

MESSRS. NATHANIEL COLGAN, M.R.I.A., and Reginald Scally, F.L.S., friends of the late Mr. A. G. More, one of the joint authors of "Cybele Hibernica," the standard flora of Ireland, have in the press a new edition of this work. It will present some novel features, and embody much information collected by its original authors.

DR. JOHN MURRAY, Director of the Scottish Marine Station, and a member of the "Challenger" expedition, has received from the German Emperor, as King of Prussia, the distinction of knighthood in the Order Pour le Mérite, founded by Frederick the Great. This is a very rare honour. Lord Kelvin, Lord Lister and Sir G. G. Stokes are the only British men of science now living who have received the Order.

MR. JOHN C. NIMMO, of London, is about to publish in two volumes, large 8vo, at the price of £1 10s., the Journals of the celebrated American naturalist, Audubon. This will be the first time his journals have been printed in full. The work is to be edited by his granddaughter, Maria R. Audubon, with notes by Dr. Elliott Coues, which is a guarantee for the scientific accuracy. The volumes will contain a number of illustrations.

ON the motion of Sir John Lubbock, M.P., F.R.S., the House of Commons have ordered a return to be made of the income and expenditure of the British Museum "Special Trust Funds" for the year ending March 31st, 1898, and a return of the number of persons admitted to the Museum in each year from 1892 to 1897, together with a statement of the progress made in the arrangement and description of the collections, and an account of the objects added to them in the year 1897.



**WINTER FLOWERING OF PLANTS.** On January 1st, there were flowering in our garden Christmas-roses, violets, stocks, wallflowers, marigolds, *Anabis*, China and other roses, some in good condition. Filbert-nut bushes were in full catkin. Daisies were and are flowering everywhere around us.—[Mrs.] Emily J. Climençon, *Shiflake Vicarage, Henley-on-Thames.*

**COLT'S-FOOT.**—It may, perhaps, be worth while recording that the colt's-foot (*Tussilago farfara*) was in full blossom on February 14th, 1898, on the embankment near Grosvenor Road Railway Station, S.W. This is a month before its time, but it is welcome as one of the first harbingers of the "sweet days of spring."—E. A. Martin, 69, *Bensham Manor Road, Thornton Heath.*

**EARLY FLOWERING OF COWPARSNIP.**—In the landslip between Ventnor and Shanklin, I found yesterday a plant of cowparsnip (*Heracleum sphondylium*) in flower. Two umbels were fully out and others were in bud. The plant was against a piling facing south or south-east. It was a healthy plant about eighteen inches high. I enclose a branch of one of the umbels.—Frank Sich, *junv., Niton, Isle of Wight; February 18th, 1898.*

**EARLY FLOWERING OF ELM.**—It may interest some of your readers to put on record that one of the many results of the very mild winter is, that the elm trees (*Ulmus campestris*) have come into flower in February. This has only occurred once before in my experience during a period of twenty years, and this year they are even earlier than on the occasion noted before, viz., February 6th, 1898, as against the last week in February, 1885.—Edwin E. Turner, *Coggeshall, Essex.*

**THE MILD WINTER.**—The following plants were in blossom in our garden on November 20th: roses, strawberry (with green fruit), broad bean, marigolds, geraniums, mignonette, wallflower, lobelia. A first sharp frost occurred during the night of November 25th-26th, but, nevertheless, roses were still in bloom the second week in December. I noticed the first primroses on December 15th, and by January 15th they were well in bloom together with snowdrops. Gorse was also out at this date. I found hazel-catkins in the hedges in the last week in January. At the time I write (February 17th) there are some fully-open blossoms on our almond tree, rose trees are covered with new leaves and buds are unfolding on the apple and pear trees.—[Miss] H. C. Brine, *Westdean, Winchester.*

**HABITS OF OWLS.**—Some of your readers may remember that in June last (*ante p. 18*) I mentioned a large wood owl which for about a month roosted by day in a cedar tree some twenty yards away from our house. It left about May 9th, and was no more seen during the summer. In December, however, two of these owls were seen in the same tree, where they continued to sit day by day, huddled close together. As all birds and animals are protected in our grounds, it has been interesting to watch the confidence towards us of

these two birds for some time past. Their place of roosting is less than ten yards from a well-frequented path, leading to the river tow-path—Emily J. Climençon.

**AQUARIA IN WINTER.**—The various animals in my glass jars aquaria, kept on a window-ledge in our drawing-room, have flourished admirably during the past winter. With the exception of a change of water on January 1st, they have been untouched for between four or five months. A little water to compensate for evaporation only has been added to them when necessary. Among the more active inhabitants have been some scarlet and green-brown mites, which have bred, and I have now some lovely specimens. I have found a few dead willow leaves placed in the water most useful for feeding many of my captive aquatic creatures, which eat out the softer parts, leaving quite a skeleton of the rest of the leaf. Dead poplar leaves have also been equally useful.—Emily J. Climençon.

**NEWSPAPER NATURAL HISTORY.**—A correspondent sends us a cutting from the "Bristol Daily Press" which is amusingly like that quoted by us last month (*ante p. 272*), in which butterflies are said to have been fed on cabbage. Our correspondent remarks that "it would add to the reputation of the papers if an editorial remark were added to these effusions correcting the error. Probably, however, most of the editors are no wiser than the writers."

"A week ago (on Tuesday, January 25th) a yellow butterfly found its way into our room here, and again yesterday (Tuesday) another of the same kind came in. We have kept the first in a small box with holes pierced in it, and every time the cover is taken off the butterfly flies about the room as lively as when it was first caught. When we caught the second and put with the first, it flew round and round, as if glad of company. The only thing our guests have had to eat is a little cabbage, which we pick fresh from the garden every day.—C. Howell, 33, *Gratitude Road, Lower Easton, Bristol; February 2nd, 1898.*"

We quite agree with our correspondent that it is disgraceful such gross ignorance should be perpetuated and spread by the conductors of newspapers, who would feel indignant if it were suggested that they were imperfectly educated.—Ed. S.-G.

**CLEANING LENSES WITH PITH.**—In the "Scientific American" is a note recommending vegetable pith for cleaning optical lenses. The medulla of rushes, elders, or sunflowers is cut out, the pieces dried and pasted singly by the side of one another upon a piece of cork. A brush-like appearance is thus obtained, which is passed over the surface of the lens. For very small lenses pointed pieces of elder pith are employed.

**VARYING DISTANCE OF THE SUN.**—Will readers please note that the mean distance from the sun shown under this heading last month (*ante p. 273*) was quoted from the work then being considered, viz., "Climate and Time." Of course, since the date of its publication, the mean distance has been shown to be greater, being in fact nearly 93,000,000 miles.—Edward A. Martin.

**A FUNGOID PIGMENT.**—Mr. David Paterson, of Rosslyn, N.B., writing to "Nature," suggests that the fungoid disease on oats, known as the "smut," may be used as an artist's pigment. He says that after exposing the pigment on paper, as a water-colour, to direct sunlight for several months, no appreciable fading was observable. Its deepest tones are fine sepia brown, and it mixes well with Chinese white and other pigments.

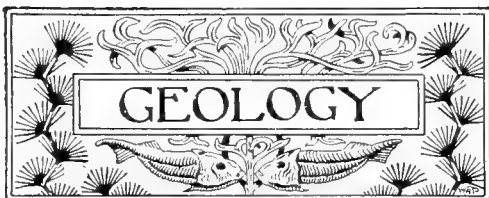

CONDUCTED BY EDWARD A. MARTIN, F.G.S.

To whom all Notes, Articles and material relating to *Geology*, and intended for *SCIENCE-GOSSIP*, are, in the first instance, to be addressed at 69, Bensham Manor Road, Thornton Heath

**NEW OFFICERS OF GEOLOGICAL SOCIETY.**—We note with much pleasure the election on February 18th of Mr. W. Whitaker, B.A., F.R.S., as President of the Geological Society of London. Mr. Whitaker is chiefly known by his important Survey Memoir on the "Geology of London," and his election is a popular one. The two new Vice-Presidents are Prof. J. W. Judd, C.B., LL.D., F.R.S., and the Rev. H. H. Winwood, M.A., whilst Prof. T. G. Bonney, D.Sc., LL.D., F.R.S., and Mr. J. J. H. Teall, M.A., F.R.S., still retain office as Vice-Presidents. Mr. J. E. Marr, M.A., F.R.S., retires from one of the secretaryships, and is replaced by Mr. W. W. Watts, M.A.

**IGNEOUS FRAGMENTS IN BAGSHOT BEDS.**—At the meeting of the Geological Society of London on January 19th Mr. H. W. Monckton read a paper "On some Gravels of the Bagshot District." The subject is in continuation of former papers published in the "Quarterly Journal" 1892 (p. 29) and 1893 (p. 308). In discussing the paper Mr. W. H. Shrubsole mentioned that in about 1878 he had found many irregular fragments of igneous rocks imbedded in the upper part of the Lower Bagshot Sand at Mill Hill, Sheppey. They were judged to have been conveyed from Scandinavia, and probably ice was the transporting agent.

**ON HUMUS.**—In the January number (*ante* p. 242) there is a note anent humus, which, as defined by Bertholet and André, is that portion of the remains of vegetation which resists the action of the air and lower organisms and remains as an insoluble residue in the soil, supplying the roots of the higher plants with nitrogen, sulphur, phosphorus, alkalies, etc. It contains about 34 per cent. organic matter. In some humid soils the amount of humus reaches 5 per cent. as against 0.75 per cent. yielded by arid soils. Pasture and some forest soils are much richer in it than are arable soils. For purposes of investigation the air-dried soil is placed on a filter and repeatedly saturated with water; the filtrate, which is usually acid in reaction, is evaporated to a small bulk, and the pale-brown, syrupy liquid is filtered and evaporated to dryness. The residue is treated with water when the ulmic, geic and humic acids, combined with bases, remain undissolved, whilst crenic and apocrenic acids, as ammonia salts, are dissolved. According to Eggerton, however, humic and ulmic acids do not naturally occur in peat and similar products, but are merely artificial laboratory products, and the existence of humine and ulmine is very doubtful, while crenic and creno-hydrochloric acids doubtless do exist as independent bodies. It is known that the decay of vegetable matter is brought about by attacks first of bacteria, when it becomes acid, and when these decay the ammonia produced neutralises the acid; and then, secondly,

moulds appear to grow in the neutral medium. Finally, both bacteria and moulds develop together. Soils which are rich in humus are looser; they have a great power of taking up water and of "absorbing" and retaining the alkalies dissolved therein. It is supposed that the moulds, not the bacteria, take an active part in the mineralization of organic nitrogen. No doubt the amount of combined nitrogen is much increased by these agents. What is more wonderful is that the plant responds to the circumstances; it spreads out its roots in all directions in order to make the most of the humus, which is very nutritious. It is extremely doubtful if the humic acids (if indeed such exist at all, at least in the free state) exert much influence in the disintegration of rocks, even of soft, porous limestone. Excessively comminuted as is the soil when it becomes deficient in water, the accumulation of humus is retarded; but where, on the other hand, the soil is permeable only to a small depth by water this accumulation is increased. The penetration of limestone by the fine roots of plants may help to disintegrate it, but it is much more probable that carbonated rain-water is the most potent agent in the weathering thereof and the formation of holes like inverted cones.—(*Dr.*) P. Q. Keegan, Patterdale, Westmoreland.

**INDIANA PETROLEUM.**—A mass of interesting geological information in regard to the natural resources of Indiana is contained in the report recently published by W. S. Blatchley, the State Geologist. The petroleum industry started here only in 1891, and in five years the output reached 4,659,000 barrels. In 1896 no less than 1,180 new borings were put down in search of oil, and of these 158 were dry. The producing territory comprises about 400 square miles. The average age of an oil-well is said to be about five years, and a number of the first wells put down have already been abandoned. Surface indications of oil seem to be quite unreliable, but where oil does occur, it is met with at depths varying from 700 to 1,500 feet below the surface.

**NATURAL GAS.**—In Indiana there is an area of 2,500 square miles over which, roughly speaking, natural gas is obtainable. No other State in the Union has so large a productive area. There is evidence to show, however, that in much of this area the supply of gas is failing, although in an area of some 400 square miles in the heart of the field there are few signs of water or other influences tending to diminish the supply of the gas. We note that some manufacturing establishments are said to consume half-a-million or more feet a day. One can scarcely wonder that the speedy exhaustion of the supply is considered a certainty in the near future. By careful consumption a decade may be passed before extinction is reached.

**FOREIGN BOULDERS IN THE CHALK.**—In answer to your note in *SCIENCE-GOSSIP* on foreign stones in chalk, I have a piece of granite that I found on the beach about a mile from Margate; although not *in situ* in the chalk, but loose, I have no doubt that it came from the chalk. It is a pinkish colour with large felspar crystals, and is unlike any granite that I know. There are no buildings anywhere near built of granite, whence it might have come, and there are not any in Margate with granite like this. It has not been rolled much, the angles being too sharp. I have worked the cliffs of the Isle of Thanet for some years now, but have never seen anything in the way of granite before.—*Thos. Edwards, Cliftonville, Equity Road, Leicester.*

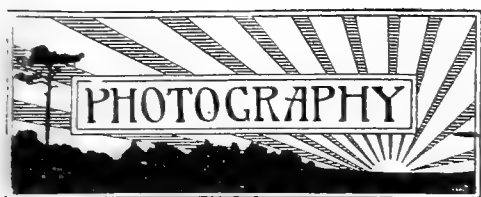

**ORTHOCHROMATIC PHOTOGRAPHY.**—The term "orthochromatic" photography, or "isochromatic" photography, is applied to the process of producing "colour-correct" negatives. Some colours, as we know, are more actinic (photographically) than others; thus the dry plate is more sensitive to rays of light reflected by blue and violet objects than it is to red and yellow rays. Yet such yellow rays may appear to the eye brighter than do the blue. If we photograph the sun's spectrum upon an ordinary gelatino-bromide plate, a print from the resultant negative would show that portion represented by the red section of the spectrum as quite black, the orange and yellow nearly so, while the blue would appear perfectly white and the deeper shades of violet and indigo much lighter than they really were. If we photographed together a bunch of forget-me-nots and primroses the latter would appear much darker than the former, although to the eye the reverse is actually the case. This is due to the fact that yellow are the illuminating rays which affect our eyes most, whereas the blue are the chemical or photographic rays, and these almost exclusively act upon the photographic plate. It is, then, to lessen the actinic power of the blue and violet rays and to increase the power of the yellow and red rays that orthochromatised plates are prepared, and a colour screen employed during exposure.

Gelatino-bromide plates may be orthochromatised either during the mixing of the emulsion, or after coating or drying the plate. In both instances it is effected by staining the emulsion with a coal-tar dye of an orange-red colour—generally of the eosin group. Eosin itself, erythrosin, rose Bengal, cyanine, and other shades, can be and often are used; for it is practically impossible to produce perfectly orthochromatic plates, that is, a plate that will show correct colour values in relation to the visibility of the whole of the colours of the spectrum. Different dyes are therefore used for special classes of work; thus, if the object to be photographed consist chiefly of red, cyanine should

be employed; while rose Bengal and erythrosin sensitive for yellow, and eosin for green and greenish yellow. A very weak solution of the dye is necessary—about one part in 10,000 being sufficient.

The addition of the dye to the film tends perhaps to decrease the rapidity of the plate, but that can be recovered by the addition of about one per cent. of ammonia to the solution or emulsion.

The subjoined diagram will show the effect of different dyes when photographing the spectrum, the height of the curves showing the relative degrees of sensitiveness at those parts.

The dotted lines represent Fraunhofer's lines, viz., *a*, red; *b*, orange; *c*, yellow; *d*, green; *e*, indigo blue; *f*, violet; and *g*, ultra violet.

It will be observed that the application of dyes to the emulsion does not affect its sensitiveness to the blue rays to any appreciable extent in either direction. If it be desired to obtain still greater

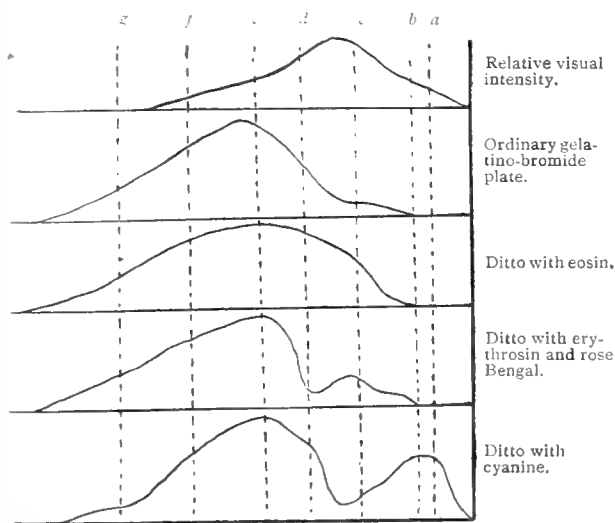

DIAGRAM OF EFFECT OF DYES.

action at the red end of the spectrum in relation to the sensitiveness of the blue and violet rays, it is necessary to obstruct the latter, while the red and yellow rays are permitted to reach the sensitive plate without hindrance. This is done by imposing a transparent yellow screen between object and plate. Such a screen is generally fixed directly in front of the lens or in the lens mount, and is made of glass, with perfectly plain parallel surfaces, or of a thin film of collodion tinted to the desired shade.

The use of such a yellow screen greatly prolongs the time of exposure necessary, as it cuts off a large proportion of the most actinic rays, and its use will be found necessary only in exceptional cases, such as highly-coloured pictures, flowers, etc.

It is by no means a simple matter to stain coated plates satisfactorily, but many makers now supply orthochromatic plates, the dye being added during the preparation of the emulsion, which are cleaner and of more equal sensitiveness than the photographer could secure by colour-sensitising his own plates. Being so sensitive to yellow and red, orthochromatic plates must be manipulated with the utmost care in the dark room. The light employed must be well diffused and of a very deep-red colour; the orange light, which is found perfectly safe for ordinary plates, will not do, and the plates should be exposed to this light as little as possible until, at all events, development is well advanced.—C. C. Vevers, 103, Briggate, Leeds



CONTRIBUTED BY FLORA WINSTONE.

LA FEUILLE DES JEUNES NATURALISTES (Paris, February, 1898). M. Dollfus announces that, thanks to various gifts and loans, the exhibition of collections mentioned in the last number of this periodical and referred to in SCIENCE-GOSSIP, *ante* p. 274, is now completed and on view. The "Discussion upon the base of the Chloritic Marl Stratum," by M. Gustav F. Dollfus, concludes with a short summing up of the matter which has appeared in former articles. M. Ernest Andrée continues his "Synopsis of the Mutillides of France." He follows the same method as previously of describing first the males and then the females of each genus. M. Ch. Van Kempen writes in an interesting manner of the birds most common in the North of France. He deplors equally with M. Xavier Raspail, who wrote on this subject in the December number of "La Feuille des Jeunes Naturalists," the gradual disappearance of birds in France. He asks what they will do for insect destroyers when the swallow and tomtit are looked upon as rarities. The sparrow-hawks are all too plentiful, as they help to diminish the other birds. Owls, woodpeckers, larks, wagtails and one or two others are still fairly plentiful, but tomtits, kingfishers, blackbirds, linnets, robin-redbreasts and many others are becoming gradually less in numbers year by year. M. Van Kempen's observations extend over several years.

ALBUM DE NATUR (Haarlem, February). Herr J. Sturing writes on "Botany in Winter." The article is illustrated by fourteen figures of some of the plants described. Among the principal are *Alnus glutinosa*, *Betula alba*, *Prunus spinosa*, *Mahonia aquifolium*, *Ilex aquifolium*, *Viscum album*, *Hedera helix*, and *Quercus cerris*. Herr M. Buijsman has an article on "Mexico, the land of the Toetromst"; the plants he describes are the tobacco, which is evergreen in Mexico, coffee, vanilla, coca trees, banana trees, indiarubber, and many others.

BULLETIN DE LA SOCIÉTÉ ZOOLOGIQUE DE FRANCE (Paris, 1897). This number contains the "Rules for Zoological Nomenclature" which were drawn up by the International Commission appointed by the International Congress of 1895 to study this important question. It met at Baden-Baden in August last, under the presidency of Professor Carus. The rules drawn up will be submitted to the Zoological Congress at Cambridge, at their meeting in 1898. This article is dealt with at length in an earlier part of this number. M. Maurice Pic writes a description of "Asiatic Coleoptera of the family Cerambycidae." He describes six species, two of which are new, viz., *Mallosia brevipennis* and *Phytacia bangi*. M. Jules Richard records the "Entomostraces" collected by M. Ch. Rabot at Jan Mayen and Spitzberg. There are not many new species among the list; only a few of which are described in this number. The article is illustrated by three figures. M. Ad.

Dollfus contributes a note illustrated with seven figures on the "*Tanaiidae* received from the Azores during the voyages of the 'Hirondelle.'" Eight new species are fully described. An account of the departure of the Belgian Antarctic Expedition is given by MM. E. Hérouard and J. Guiart. They give a short history of what has been done towards the discovery of the South Pole. Hearing so much of the expeditions to the North Pole, people are apt to forget that the investigation of the Antarctic region would be fully as valuable to science. The aim of the expedition which has recently started to the South Pole is not to find the exact position of the Pole itself, but to elucidate certain scientific questions. The members propose to study the magnetic phenomena, atmospheric electricity and the hygrometric state; also the plants and the animals. A full description is given of the preparations made by these explorers, who expect to be absent two years, and the vessel in which they sailed, named the *Belgica*. M. de Gerlach is the chief of the expedition and also captain of the ship. He is accompanied by twenty-one comrades.

BOLLETTINO DEI MUSEI DI ZOOLOGIA ED ANATOMIA COMPARATA (Turin, November, 1897). M. C. F. Ancey gives an account of the malacological species obtained by Dr. Barelli from the Argentine Republic and Paraguay. The species described are all in the zoological museum of the Turin University. The new species are *Ephyragnophora erythromphala*, Anc., *Buimulus borellii*, and *B. pollonevae*. There is a beautiful plate containing fourteen figures of the shells, the new species being amongst them.

COSMOS (Paris, February 12th, 1898). M. A. Berthier contributes an article, illustrated with two diagrams and one photograph, of a "Telephone with a Double Cylinder," which he has invented. His object is to regulate the magnetic movement of the electro magnet so as to obtain the maximum of effect. There are some interesting notes by M. A. Acloque, on "The influence of a Medium Climate upon Vegetable Growth." They are illustrated by one figure showing the influence of the sun upon the facies of plants. The development of *Mimulus tilingii* is shown (1) under ordinary sunlight, and (2) under a feeble sunlight. The Physical Astronomy Observatory at Meudon is described by M. Louis Rabourdin, with illustrations, giving a general view of it from the terrace, the central pavilion and its cupola, the grand equatorial of Meudon, and a general view of the observatory from the higher terrace. It was the discoveries made in France on the spectrum analysis and the constitution of the sun, in 1862 and 1871, which decided Paris to build an astronomical observatory. It was founded in 1875, after several efforts having been made in previous years to obtain the necessary vote.

LA NATURE (Paris, February 12th, 1898). M. R. Bergeot gives an account of an establishment at St. Lambert, conducted by a Parisian named M. Philipon, for the application of the newest methods in the breeding of salmon. M. A. Acloque describes the "Germination of Truffles," giving an illustration from a microscopic plate of the fertilization of the spores of truffles. A new system of cinematograph is described and illustrated by M. J. Laffargue. Mr. F. Jenkins is the inventor of this new system, which aims at a continuous movement instead of the occasional stoppage of the band as at present.



THE SOUTH LONDON ENTOMOLOGICAL AND NATURAL HISTORY SOCIETY.—January 13th, 1898. Mr. R. Adkin, F.E.S., President, in the chair. Mr. Mansbridge exhibited a photograph of an ash and an elm tree taken in winter to show the distinctive character of their branching. Mr. Adkin, minor varieties of *Pararge megera*, and contributed notes thereon; also a specimen of the curious Turbellarian worm, *Bipalium kewense*, found crawling over the ferns in a friend's greenhouse. Mr. W. G. Pearce brought a series of very dark *Hemerophila abruptaria* bred from ova laid by a female captured in North London. The Secretary read a paper communicated by Professor A. Radcliffe Grote, A.M., entitled "The Wing and Larval Characters of the Emperor Moths," and exhibited the following species in illustration: *Saturnia favonia*, *Agria tau*, *Automeris io*, *Hemileuca maia*, *Citheronia imperialis* and *Attacus speculifer*, kindly lent by Mr. C. G. Barrett.—January 27th. Annual Meeting, the President in the chair. Reports of the satisfactory condition of the Society were read from the Council and Treasurer. The following officers and Council were then elected: President, J. W. Tutt, F.E.S.; Vice-Presidents, R. Adkin, F.E.S., W. Mansbridge, F.E.S.; Treasurer, T. W. Hall, F.E.S.; Librarian, H. A. Sauzé; Curator, W. West; Hon. Secretaries, Stanley Edwards, F.L.S., H. J. Turner, F.E.S.; Council, T. A. Chapman, M.D., F.E.S., F. Clark, A. W. Dennis, A. Harrison, F.E.S., F.C.S., W. J. Lucas, B.A., R. South, F.E.S., H. Tunaley, F.E.S. The retiring President then read his address. He dealt at length with matters concerning the well-being of the Society, summarized the entomological work of the past year, referred in detail to the more important works which had recently been published, and then passed on to a general consideration of the bearing of the theory of evolution on our views of nature. Mr. Lucas exhibited a specimen of the earwig, *Forficula lesnei*, taken at Reigate in October, 1897, by Mr. West (Greenwich), of which only two specimens had previously been recorded in Britain, and contributed notes on its structure, habits and occurrence.—February 10th, Mr. J. W. Tutt, F.E.S., President, in the chair. It was announced that Mr. Mansbridge had resigned owing to his leaving England, and that Mr. Tunaley, F.E.S., had been chosen to fill the vacancy as Vice-President, and that Mr. H. Moore had been elected on the Council. Mr. McArthur exhibited underside varieties of *Polyommatus bellargus* and *P. corydon*, the latter being almost devoid of ocelli. Mr. Dennis, three-parts-grown larvae of *Callimorpha hera* from ova, sent by Mr. Tutt while collecting in the Alps in 1897. They had fed all the winter. Mr. Tunaley, long bred series of *Retinia resinella* from Aviemore. Mr. Routledge, a variety of *Enodia hyperanthes*, from Carlisle, having a broad whitish submarginal band on the undersides of the hind wing embracing the ocelli, and also two females of *Acosmetia caliginosa* taken in the same locality by Mr. Day. Mr. Lucas, imagines and living nymphs

of *Calopteryx splendens* from Fleet, and contributed notes on the specific characters and habits of the nymphs. Mr. Adkin, specimens of *Dianthaecia luteago* var. *barrettii*, from Howth. Major Fickin, the same species taken in Cornwall, and which form Mr. Tutt has named var. *ficklini*. Mr. Tutt, on behalf of Rev. F. E. Lowe, of Guernsey, a third form bred from pupa taken under *Silene maritima*, and which he had named var. *lowei*. A considerable discussion ensued on the singular variation shown in this species, practically invariable in the same locality, but each locality possessing a distinct race. Mr. Tutt also exhibited, on behalf of Mr. Lowe, a fine aberration of *Melanippe sociata*, in which the central band of the wings was almost completely obliterated; and, on behalf of Mr. Pearce, of Hackney, all the melanic specimens of *Hemerophila abruptaria* bred by him during the last three years, some dozens, including extremes and intermediates, and one partially gynandrous specimen.—H. J. Turner, Hon. Rep. Sec.

ROYAL METEOROLOGICAL SOCIETY.—On February 16th, at the Institution of Civil Engineers, Westminster; Mr. F. Campbell Bayard, President, in the chair. Mr. E. Mawley, F.R.H.S., gave a report on the phenological observations for 1897, from which it appeared that there had been a marked absence of very exceptional weather during the past phenological year, the most noteworthy features affecting vegetation being the persistent rains in March and the three dry periods of May, July and October. Until about the middle of May, wild plants appeared in blossom in advance of their usual time, but throughout the rest of the flowering season they were all somewhat behind their average dates in coming into bloom. The heavy rainfall in the early spring favoured the hay, which proved the only really abundant farm crop of the year, but greatly impeded the sowing of spring corn. The cereals were, however, much benefited later on by the warm, dry and brilliant weather of the summer. Taking the country as a whole, oats proved a good crop, barley an average one, while the yield of wheat was somewhat under average. There were also fair crops of roots and potatoes. It was owing more to the dry spring and summer and the sunless autumn of the previous year than to the moderate frosts and cold winds of the spring of 1897, that the fruit crop was such a very light one. Apples, pears and plums, and especially the latter, yielded badly, while the small fruits were in most districts only average crops. Mr. J. Hopkinson, F.L.S., read a paper on "Monthly and Annual Rainfall in the British Empire, 1877-96." In this the author gave particulars of the mean monthly and annual rainfall, and the number of rainy days at the following twelve stations in the British Empire, viz.: London, England; Port Louis, Mauritius; Calcutta and Bombay, India; Colombo, Ceylon; Adelaide and Melbourne, Australia; Wellington, New Zealand; Toronto and Winnipeg, Canada; Kingston, Jamaica; and Malta.

ROYAL INSTITUTION.—Speaking at the Royal Institution on "Buds and Stipules" on January 21st, the Right Hon. Sir John Lubbock said that he had been struck, some years ago, by a remark of Vaucher's that some rockroses have "stipules," or small leaflets, at the base of the leaf-blade, and some have none. Vaucher observed that it was very curious that plants so nearly allied should differ in this respect, and that it would be interesting to endeavour to determine the reason. After explaining why this was so, Sir John said that the



study of stipules had led him on to that of buds, and he explained the structure of the winter bud in many of our common shrubs and trees, which differ greatly in the mode in which the young leaves are protected against the cold of winter. The young leaves and flowers are formed early in the preceding autumn. He showed the flowers and leaves of the coming summer, and in the case of the pine, even the leaves of next summer year. He explained the reason for some of the different forms of stipules, and showed how, in many cases, the structure and form of the bud influenced the forms of the leaves. He pointed out that the seed leaves, or cotyledons, differed from the subsequent leaves, being influenced not by the form of the bud, but of the seed, and showed, for instance, how the form of the seed leaf of the mustard was thus determined. The lecture was illustrated by many specimens and some beautiful diagrams, and Sir John concluded by saying that he hoped he had explained, at any rate in some cases, the presence, the uses and the forms of stipules, and the structure of buds in some of our common trees and shrubs. If he should have induced his hearers to look at them for themselves in the coming year's spring they would be amply rewarded. They would often be reminded of Tennyson's profound remark about Nature—"So careless of the single life, so careful of the type she seems"—and they would, he was sure, be more and more struck with wonder and admiration at the variety and beauty of the provisions by which Nature preserves these tender buds from the severity of winter, and prepared and provided, with rich profusion, for the bright promise of spring and the glorious pageant of summer.

CITY OF LONDON ENTOMOLOGICAL AND NATURAL HISTORY SOCIETY.—Mr. J. W. Tutt, F.E.S., President, was in the chair on January 4th. Exhibits included: Mr. May, series of *Agrotis nigricans*, and also a small one of *A. tritici* from Sandown, Isle of Wight. Mr. Bacot narrated an experiment he had made with some larvae of *Chœvocampa elpenor*, which he had kept in water for various periods ranging from one to thirty-two hours, but all of which had subsequently revived with every appearance of perfect health. Mr. Tutt narrated a somewhat similar experiment on the part of Mr. Tunaley with *Smerinthus populi*. Dr. Chapman had known earwigs recover after being swollen with water to such an extent that decomposition was setting in. A discussion took place on the subject, the President pointing out that many insects, amongst others the larvae of *Phovodesima smaragdaria*, must possess water-resisting power in a very high degree, either in themselves or the silk with which they surround themselves, as the marshes on which they live are so frequently swamped by the tide. Mr. Jennings read an explanatory paper on the Order Hymenoptera. Messrs. Sauzé, Tremayne and H. Heasler, Dr. Chapham, and Messrs. Bacot, Prout, and Nicholson took part in the discussion which followed, and Mr. Jennings replied.—January 19th. Mr. Louis B. Prout, F.E.S., Vice-President, in the chair. Exhibits: Mr. Garland, *Odontoptera bidentata* from various localities, showing variations, *Anarlia myrtille* from Oxshott, showing one with black tips on forewings; *Venilia macularia* from the New Forest, being rather darker than usual; *Caillimorpha hera* from South Devon. Mr. H. Heasler, *Calodera umbrosa*, taken by sweeping at Boxhill last August, the only British member of the genus likely to be

taken in this way, as the rest are found in marshy places on the ground; *Homolota atomaria* taken with above, a widely distributed but rare species; *Aleochara succicola* taken in putrid fungus at Wood Street, Walthamstow, last November; *Tetvatoma fungorum* taken in fungus growing on a pollard oak in Wood Street, last November. Mr. S. J. Bell, four large coloured plates, figures of British lepidoptera, birds, flowers and birds' eggs, presented by Messrs. Colman to principals of secondary schools. The curators put part of the Society's collection on view. Mr. Bacot had been continuing his experiment with pupae of *Chœvocampa elpenor*, which were still living after being under water eight days. Mr. Tremayne read a paper on "Darwin."—February 1st. Mr. J. W. Tutt, F.E.S., President, in the chair. Exhibits: Mr. Donnisthorpe exhibited rare coleoptera collected during the year 1897. Mr. W. G. Pearse, a large case of specimens of *Hemerophila abruptaria*, either collected at Holloway or bred from ova obtained from captured insects, showing the ordinary light forms, series of very dark-brown forms, and series of intermediate forms, with the dark-black band showing through the dark-brown ground colour of the wings. One female possessed one male and one female antenna. Mr. Stanley Austin read a paper on "The British Corvidæ," which was illustrated with a fine exhibit of eggs on the part of Mr. Wm. Bayne.—Lawrence J. Tremayne, Hon. Sec.

NORTH LONDON NATURAL HISTORY SOCIETY.—January, 1st and 3rd. Sixth Annual Exhibition in the Lecture Hall of the North-East London Institute, which was prettily arranged and numerously attended. On January 1st, Mr. J. E. Greenhill, F.G.S., delivered a half-hour lecture on "Flint Flakes," which was much appreciated. Short lectures were given by Mr. C. Nicholson on "Astronomy," by Mr. Jennings on "Predatory Insects," and by Mr. R. W. Robbins on "The Colours of Flowers." The principal exhibits were a splendid collection of photographs of birds and their nests by Mr. J. C. Hills; a hippopotamus skull, elephant and rhinoceros tusks, etc., by Mr. W. H. Barber; ornithological specimens by Mr. D. C. Barber; foreign lepidoptera by Dr. Sequeira; and plants by Messrs. Hanbury and C. S. Nicholson. Ornithology and general zoology were more to the fore than in previous years.—Mr. R. W. Robbins, President, was in the chair on January 6th. Exhibits: Mr. Jennings, three specimens of *Aphanus pini*, L. (Hemiptera, Heteroptera, Lygocidae), taken by Mr. W. H. Smith and himself on December 27th, 1897, in Epping Forest amongst grass and ling; Mr. L. J. Tremayne, specimen, sent by Dr. Abbott, of a thin, white, silky-looking membrane which formed the lining of small cells made by an insect in the Tunbridge Wells sandstone. No one present could name this insect. The Presidential Address was read.—January 29th. Visit to the Horniman Museum, Forest Hill. The members assembled at the Museum at 3 p.m.; the party was met by Mr. Quick, the Curator, who made a gallant effort to show us round. Unfortunately the Museum was about to close for the purpose of rebuilding, and, being the last day, the house, which is not very commodious, was crowded with people. Under these circumstances anything like an organized demonstration was impossible.—Lawrence J. Tremayne, Hon. Sec.

GREENOCK NATURAL HISTORY SOCIETY.—A meeting of this Society was held in the MacLean Museum, Watt Institution, on January 27th. There



was a good attendance. The President, Mr. M. F. Dunlop, made an interesting communication regarding the discovery of a new rotifer. In the summer of 1896, when leaving Arran after a few weeks' holiday, Mr. Dunlop took with him a gathering from a small mossy pool in a moorland district at West Benan, some five hundred feet above the level of the sea, which he intended for careful examination at home. When this was undertaken shortly afterwards, under the microscope, and while the observer was engaged watching the movements of a well-known rotifer, he was surprised to notice a strange form smoothly and slowly gliding out of the moss. It was immediately dipped out of the trough and mounted on a slide for the microscope. The specimen has since been seen by Mr. Dixon-Nuttall, Mr. Rousselet, and other authorities, who agree that the rotifer had not been previously observed, and to which the name of *Metopidia fterygoida* has been given. In October last, Mr. Dunlop found another specimen in a small pool at the side of the curling pond adjoining the Old Large Road above Greenock. A mounted specimen of the new rotifer was shown under the microscope, and living specimens were also shown by other rotifers. Lantern slides were also shown by Mr. George Dunlop, B.L., illustrative of the subject. The lecture was much appreciated by those present.—G. H. Niven, *Hon. Sec.*, 23, *Newton Street, Greenock*.—The rotifer *Metopidia fterygoida* is illustrated in "The Journal of the Queckett Microscopical Club" ser. ii., vol. vi., April, 1897.—ED. S.G.]

## NOTICES OF SOCIETIES.

BATTERSEA FIELD CLUB AND LITERARY AND SCIENTIFIC SOCIETY, Public Library, Lavender Hill, S.W.

- Mar. 3, 17, 31 and April 14.—"Elementary Geology." G. W. Young. 8 o'clock sharp.  
 April 23.—"The Geology of Surrey," with special reference to scenery. G. W. Young.  
*Excursions:*  
 Mar. 5.—Western Gallery, South Kensington, Botanical Section. Conducted by Mrs. W. P. Young.  
 April 23.—Oxshott Heath and Stoke D'Abernon. Conducted by the Hon. Sec.  
 May 23.—Hayes and Keston Commons. Conducted by the Hon. Sec.  
 June 11.—Anstiebury and Leith Hill. Conducted by G. W. Young.  
 " 25.—Whole-day Excursion to Sea-side.  
*Hon. Sec. E. J. Davies, Marney Road, Clapham Common*

LAMBETH FIELD CLUB AND SCIENTIFIC SOCIETY, St. Mary Newington School, Newington Butts, S.E.

- Mar. 7.—Lecture: "A Journey to the Moon." E. W. H. ...  
 " 12.—Visit to Imperial Institute.  
 " 21.—Coast Meeting. "The Myxomycetes, or Slime-Fungi." H. Sudmerson. "Our Common Trees." Short Paper by C. S. Cooper.  
 April 4.—Lecture: "Phases of Oceanic Life," with lantern illustrations. A. P. Wire.  
 " 11.—Easter-Monday Outing—Conladon and Chaldon.  
 " 21.—Visit to Zoological Gardens.  
 May 2.—Lecture: "Spring Flowers." E. J. Davis.  
 " Outing. Particulars to be announced!  
 " 30.—Whit-Monday Outing. Reigate.  
 June 6.—Annua. Meeting  
 " 11.—Outing—Stirley Hills and Addington Woods.  
 " 25.—Outing—Penvalle and Horsendon Hill  
*Hon. Sec. H. Wilson, 14, Milborne Square, Brixton Road*

SOUTH LONDON ENTOMOLOGICAL AND NATURAL HISTORY SOCIETY.

- Mar. 10.—"Photomicrographs," with lantern illustrations. Fred Clark.  
 " 24.—"A Chat on Snails." Rev. W. J. Horsley, M.A.  
 April 14.—"British and Japanese Lepidoptera Compared." R. South, J. L.S.  
 " 28.—"Hemiptera." Edward Saunders, F.L.S., F.E.S.  
 May 12.—"South European Lepidoptera." A. H. Jones, F.E.S.  
 6—Geological Lecture with Lantern Illustrations

NORTH LONDON NATURAL HISTORY SOCIETY.

- Mar. 17.—"Insectivorous Plants." R. W. Robbins.  
 " 19.—Visit to the Bethnal Green Museum.  
 April 16.—Visit to Kew Gardens.  
 " 21.—"Lepidopterous Larvae." A. Bacot.  
 May 5.—Discussion: "Nebulae." Opened by C. Nicholson, F.E.S.  
 " 21.—Half-day Excursion to Epping Forest.  
 " 27-30.—Excursion to the New Forest—leader, L. J. Tremayne.  
 " 30.—Alternative whole-day Excursion to Shere.  
 June 16.—"The Catocalidae." E. M. Dadd  
 " 18.—Whole-day Excursion to Deal—leader, L. J. Tremayne.  
 Visitors will be cordially welcomed at all meetings and excursions.  
*Lawrence J. Tremayne, Hon. Sec.*

SELBOURNE SOCIETY—CROYDON AND NORWOOD BRANCH.

- April 7.—Social Evening. Exhibits, etc., will be welcomed. Rev. F. E. J. Bird, *Vice-President*, will speak Seneca Hall, 8 p.m.  
 " 21.—Annual Meeting, at Public Hall, Croydon. Subject: "The New Forest." Rev. H. E. H. Bull, M.A. Lantern slides. 8 p.m.

NORTH KENT NATURAL HISTORY AND SCIENTIFIC SOCIETY

- Mar. 9.—"Conchology." E. Dennis.  
 " 23.—"British Birds, Eggs and Nests." D. Miller.  
 April 6.—"Lepidoptera." S. J. B. Pine.

CARLISLE ENTOMOLOGICAL AND NATURAL HISTORY SOCIETY.

- Mar. 7.—"Lepidoptera taken at light in Carlisle." J. E. Thwaytes.  
 " 21.—"Observations on Bird life." B. Johnston.  
*F. H. Day, Hon. Sec., 6, Curcock Terrace, Carlisle.*

PRESTON SCIENTIFIC SOCIETY.

- April 6.—"Methods of Fishing and Fish Culture on our Coasts." R. L. Acroft (Member of the Lancashire Sea Fisheries Committee).  
 " 20.—"Bicography of a Fern." W. Clitheroe.  
 Illustrated by oxy-hydrogen lantern.  
 Lecture Hall, Cross Street, Winckley Square, 8 p.m.  
*W. Hy. Heathcote, F.L.S., Secretary, 47, Fritchwood Street.*

HULL SCIENTIFIC AND FIELD NATURALISTS' CLUB.

- Mar. 2.—"The Natural History of Goole Moor." Thos. Bunker.  
 " 16.—"Spectroscopic Astronomy," lantern illustrations. Rev. H. P. Slade, M.B.A.A.  
 " 30.—"The Marine Fauna of the Yorkshire Coast," lantern views. F. W. Fierke, M.C.S.  
 The Meetings held at 72, Prospect Street, alternate Wednesdays, 8 p.m.—T. Sheppard, *Hon. Sec.*, 78, *Sherburn Street, Hull.*

SCARBOROUGH FIELD NATURALISTS' SOCIETY.

- Mar. 10.—"A Ramble in Kent." J. H. Burton.  
 " 24.—Exhibition of Specimens and Discussion.  
 April 7.—"A Chat on Shells." R. H. Barker.  
 " 21.—Short Papers. Members.  
 May 5.—"Anemones." J. C. Harrison.  
 " 16.—Y.N.U. Excursion to Clapham for Bowland, Notts.  
 " 19.—"An Ardent Entomologist." T. W. Lownsbrough.  
 " 30.—Y.N.U. Excursion to Doncaster for Balham and Sandal.  
 June 2.—"Chara and Nitella: their structure, life and beauty." D. W. Bevan.  
 " 16.—"Stems." Miss Major.  
 " 18.—Y.N.U. Excursion to Hovingham and Wigganthorpe.  
 " 30.—Marine Conversation.  
 Meetings held in the Museum at 8.15 p.m.  
*Hon. Secs., E. R. Cross and H. Herbert, 75, Prospect Road.*

TUNBRIDGE WELLS NATURAL HISTORY SOCIETY.

- Mar. 11.—"Torpedo Warfare." Fleet Engineer T. J. Haddy, R.N.  
 " 25.—"Honeycombing and other forms of weathering of stone." Illustrated by lantern. Geo. Abbott, M.R.C.S.  
 April 8.—"Problems in Plant Life." Benj. Lohax, F.L.S.  
 May 6.—Annual Meeting.  
 Ordinary Meetings in the Literary Society's Library, 12, Pantiles, on Friday evenings at 8.—Miss Cooke, *Hon. Sec.*, 19, *Guildford Road.*

WARRINGTON FIELD CLUB.

- March 4.—"Frog Spawn." L. Greening, F.L.S., M.R.I.A.  
 " 12.—Entomological Evening and Annual Meeting.  
 7.30 p.m., in the Museum, Lecture Room.  
*Alf. J. Jelles, Hon. Sec.*

## METROPOLITAN SCIENTIFIC SOCIETIES.

The following is a list of societies in the London district devoted to natural science, with hours and places of meeting. They may be visited with introduction from a Fellow, Member, or Secretary. Will secretaries send additions or corrections

- ANTHROPOLOGICAL INSTITUTE OF GREAT BRITAIN, 3, Hanover Square. Second and fourth Tuesdays at 8.30 p.m., November to June.
- BATTERSEA FIELD CLUB AND LITERARY AND SCIENTIFIC SOCIETY. Public Library, Lavender Hill, S.W. Thursdays, 8 p.m.
- CITY OF LONDON COLLEGE SCIENCE SOCIETY, White Street, Moorfields, E.C. Last Wednesday in each month, October to May, 7.30 p.m.
- CITY OF LONDON ENTOMOLOGICAL AND NATURAL HISTORY SOCIETY, London Institution, Finsbury Circus. First and third Tuesdays, 7.30 p.m.
- CONCHOLOGICAL SOCIETY, LONDON BRANCH, St. Peter's Rectory, Walworth. Irregular meetings. Rev. J. W. Horsley, President, will answer enquiries.
- CROYDON MICROSCOPICAL AND NATURAL HISTORY CLUB, Public Hall. Third Tuesdays, October to May, 8 p.m.
- DULWICH SCIENTIFIC AND LITERARY ASSOCIATION. Fortnightly lectures Lordship Lane Hall, second and fourth Mondays, 8.15 p.m., from October, for winter season.
- EALING NATURAL SCIENCE AND MICROSCOPICAL SOCIETY, Victoria Hall, Ealing. Second and last Saturdays. October to May, 8 p.m.
- ENTOMOLOGICAL SOCIETY, II, Chandos Street, Cavendish Square. First Wednesday, October to June (except January). Third Wednesday, January, February, March and November. 8 p.m.
- GEOLOGISTS' ASSOCIATION, University College, Gower Street. First Friday, 8 p.m., November to July.
- GEOLOGICAL SOCIETY OF LONDON, Burlington House, Piccadilly. First and third Wednesdays, 8 p.m., November to June.
- LAMBETH FIELD CLUB AND SCIENTIFIC SOCIETY, St. Mary Newington Schools, Newington Butts, S.E. First Mondays all the year and third Mondays in winter, 8 p.m.
- LINNEAN SOCIETY OF LONDON, Burlington House, Piccadilly. First and third Thursdays at 8 p.m., November to June.
- LONDON AMATEUR SCIENTIFIC SOCIETY, Memorial Hall, Farringdon Street, E.C. Fourth Friday in each month. October to May, 7.30 p.m.
- LUBBOCK FIELD CLUB. Working Men's College, Great Ormond Street, Bloomsbury, W.C. Excursions second Sundays, Meetings following Mondays, 8 p.m.
- MALACOLOGICAL SOCIETY OF LONDON, meets in Linnean Society's Rooms, Burlington House. Second Friday each month, November to June, 8 p.m.
- MINERALOGICAL SOCIETY. Meets in rooms of Geological Society, February 4th, April 14th, June 23rd, November 17th, 8 p.m.
- NONPAREIL ENTOMOLOGICAL AND NATURAL HISTORY SOCIETY, 99, Mansfield Street, Kingsland Road, N.E. First and third Thursdays, 8 p.m.
- NORTH KENT NATURAL HISTORY AND SCIENTIFIC SOCIETY, St. John's Schools, Wellington Street, Woolwich. Alternate Wednesdays, 7.30 p.m.
- NORTH LONDON NATURAL HISTORY SOCIETY, North-East London Institution, Hackney Downs Station. First and third Thursdays, 7.45 p.m.
- QUEKETT MICROSCOPICAL CLUB, 20, Hanover Square. First and third Fridays, 8 p.m.
- ROYAL BOTANIC SOCIETY OF LONDON, Regent's Park. Second and fourth Saturdays at 3.45 p.m.
- ROYAL HORTICULTURAL SOCIETY, 117, Victoria Street, S.W. Second and fourth Tuesdays, except December to February; 2 p.m. on show days, which vary.
- ROYAL METEOROLOGICAL SOCIETY, 22, Great George Street, Westminster. 3rd Wednesday, November to June, 8 p.m.
- ROYAL MICROSCOPICAL SOCIETY, 20, Hanover Square. Third Wednesdays, October to June, 8 p.m.
- SELBORNE SOCIETY, 20, Hanover Square. No winter meetings.
- SIDCUP LITERARY AND SCIENTIFIC SOCIETY, Public Hall, Sidcup. First and third Tuesdays, October to May, 8 p.m.
- SOUTH LONDON ENTOMOLOGICAL AND NATURAL HISTORY SOCIETY, Hibernia Chambers, London Bridge, S.E. Second and fourth Thursdays, 8 p.m.
- SUTTON SCIENTIFIC AND LITERARY SOCIETY, Public Hall Chambers. Second and fourth Tuesdays, 8 p.m.

WEST KENT NATURAL HISTORY, MICROSCOPICAL AND PHOTOGRAPHIC SOCIETY. Meets in School for Sons of Missionaries, Blackheath, third Wednesday, in December, fourth Wednesdays in October, November, January, February, March, April, May, 8 p.m.

ZOOLOGICAL SOCIETY OF LONDON, 3, Hanover Square. First and third Tuesdays, 8.30 p.m., November to August.

## NOTICES TO CORRESPONDENTS.

TO CORRESPONDENTS AND EXCHANGERS.—SCIENCE-GOSSIP is published on the 25th of each month. All notes or other communications should reach us not later than the 18th of the month for insertion in the following number. No communications can be inserted or noticed without full name and address of writer. Notices of changes of address admitted free.

BUSINESS COMMUNICATIONS.—All Business Communications relating to SCIENCE-GOSSIP must be addressed to the NASSAU STEAM PRESS, LIMITED, 86, St. Martin's Lane, Charing Cross, W.C.

SUBSCRIPTIONS.—Subscriptions to SCIENCE-GOSSIP, at the rate of 6s. 6d. for twelve months (including postage), should be remitted to the NASSAU STEAM PRESS, LIMITED, 86, St. Martin's Lane, Charing Cross, W.C.

Strictly Editorial communications, *i.e.*, such as relate to articles, books for review, instruments for notice, specimens for identification, etc., to be addressed to JOHN T. CARRINGTON, 1, Northumberland Avenue, London, W.C.

NOTICE.—Contributors are requested to strictly observe the following rules. All contributions must be *clearly* written on one side of the paper only. Words intended to be printed in *italics* should be marked under with a single line. Generic names must be given in full, excepting where used immediately before. Capitals may only be used for generic, and not specific names. Scientific names and names of places to be written in round hand.

The Editor will be pleased to answer questions and name specimens through the Correspondence column of the magazine. Specimens, in good condition, of not more than three species to be sent at one time, *carriage paid*. Duplicates only to be sent, which will not be returned. The specimens must have identifying numbers attached, together with locality, date and particulars of capture.

The Editor is not responsible for unused MSS., neither can he undertake to return them, unless accompanied with stamps for return postage.

## CORRESPONDENCE.

P. T. (Beckenham).—You can obtain a copy of Mr Verrall's "List of British Diptera" by applying to that gentleman, at Sussex House, Newmarket.

R. S. (London).—Hornets feed upon various vegetable and animal substances, such as honey, fruit, caterpillars of other insects, and even other perfect insects. They build their nests in convenient holes in trees, under the roofs of houses, or other sites. Their appearance in spring should be carefully watched, when the locality of the nest may be traced and the inmates destroyed before they become numerous.

## EXCHANGES.

NOTICE.—Exchanges extending to thirty words (including name and address) admitted free, but additional words must be prepaid at the rate of threepence for every seven words or less.

ISOCARDIA COR and other good marine shells. Wanted, Cyproeae, Olivae and foreign land shells new to collection.—Robt. Cairns, 159, Queen Street, Hurst, Ashton-under-Lyne.

OFFERS wanted for SCIENCE-GOSSIP (1885, 1886, 1887, 1890, 1892), polished agates, stereoscope and slides.—William Gomm, 1, Chantry Road, Clifton, Bristol.

WANTED, a cabinet for microscopic slides and a pocket aneroid.—J. H. Cooke, Thorndale, Lincoln.

WANTED, offers for the whole of SCIENCE-GOSSIP, 1865 to 1897; first 28 volumes in publisher's cover, remainder unbound.—G. P. Bonny, 20, Wellington Road, Stoke Newington, London, N.

WANTED, offers in microscopy or photography for Cassell's "British Battles on Land and Sea," complete; published last year in nineteen 6d. and 7d. parts.—A. H. Nicholson, 67, Greenbank Road, Darlington.

FOREIGN marine shells for exchange, also Australian Chitons and Ehippodonta lunata (Tate) preserved in formalin; send exchange list.—Lewis Shackelford, Clitheroe, Lancashire.

## BRITISH INFUSORIA.

By E. H. J. SCHUSTER, F.Z.S.

## PART I.—FLAGELLATA EUSTOMATA.

THE order Flagellata Eustomata comprises those infusorians which possess one or more flagelliform appendages, but no cilia, having invariably an oval aperture or cytostome more or less conspicuously developed. Reproduction is brought about by longitudinal or transverse fission, or by division of either the whole or part of the body substance into sporular elements. This latter form of reproduction, namely the formation of spores from a part only of the body substance

*Entisisphon*. In some instances this outer case may become so hardened as to form a veritable cuirass. I have often come across this "exoskeleton" of *Phacus* from which the animal has been macerated away, lying among confervæ, colourless and hyaline, but retaining exactly the contours presented by the living animal.

The development of a mouth seems to be causally related with this hardening of the external protoplasm, as the animals in question might

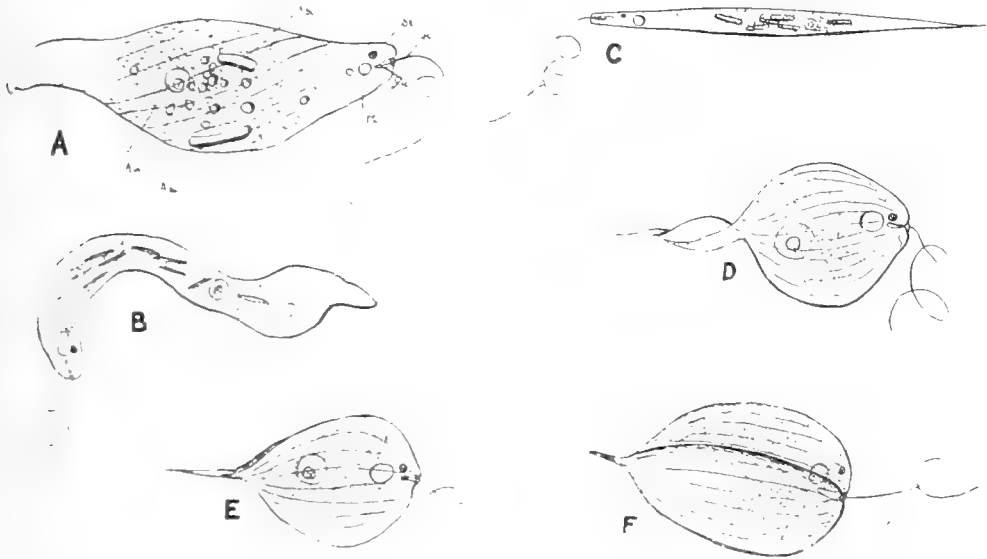
INFUSORIA  $\times 250$  (approx.).

A.—*Euglena viridis*, nu, nucleus containing nucleolus; am, amyloceous corpuscles; re, reservoir for contractile vacuole; fl, flagellum (spring from); gu, gullet; st, stigma, or "eyespot"; B, *E. desesi*; C, *E. acus*; D, E, *Phacus longicaudus*; F, *P. triqueter*,  $\times 700$ .

of the parent, is exemplified in the Euglenidae, Chryomonadidae and Anisonemidae, and points to a comparatively high organization. This characteristic, even if taken alone, would be enough to place the Flagellata Eustomata on a pinnacle far above the Flagellata Pantostomata, in which order the life of the parent is invariably sacrificed for the reproduction of the children, in a most brutal and primitive manner.

The body of the Eustomata is markedly divided into an external and internal sarcoid layer, or ectoplasm and endoplasm, the former of these often has the attributes and appearance of true cuticle, as, for instance, in *Phacus*, *Oxyrrhis*; and

otherwise find it somewhat difficult to obtain nutriment.

The following species described are of course but a very small number of those which may be met with, but they seem to me to be the commonest. I have obtained them from ponds and ditches near Yarmouth, Wimbledon, Godalming, Folkestone and Oxford. They all belong to the family Euglenidae, and to the genera *Euglena* and *Phacus*.

*Euglena viridis*, Ehrenberg. This is a very cosmopolitan species. Only once have I failed to find it in a sample of water which I supposed would contain it. That was when I examined a tube supplied by a dealer, which was labelled

*Euglena viridis*, and even there it might have been present and escaped my notice. It was described by John Harris, in 1696, from whose writing the following extract is taken :

"April 27th, 1696.—With a much better microscope I examined some rain-water that had stood uncovered a pretty while, but had not contracted any such thick and discoloured scum as that before mentioned had. A little thin white scum, that like grease began to appear on the surface, I found to be a congeries of exceeding small animalculæ of different shapes and sizes. At the same time I look't on a small drop of the green surface of some puddle water which stood in my yard. This I found to be altogether composed of animals of several shapes and magnitudes. But the most remarkable were those which gave the water that green colour, and were small oval creatures, whose middle was of a grass green, but each end clear and transparent. They would contract and dilate themselves, tumble over and over many times together, and then shoot away like fishes. Their head was at the broadest end, for they still moved that way. They were very numerous, but yet so large that I could distinguish them very plainly with a glass that did not magnify very much."

The observations of John Harris were, as far as they went, exceedingly accurate, and more recent observers working with better optical appliances, although of course they have amplified his observations to a considerable extent, have not been obliged to contradict them.

*Euglena viridis*, Ehr., is fusiform in shape and 42 to 170 microns in length; the anterior end is blunt, as stated by John Harris, and the posterior end is more or less pointed; the outside surface is marked by oblique striæ; there is a conical depression at the anterior extremity, at the base of which is situated the mouth, and from which springs a slender flagellum exceeding the body in length. It is by the lashing of this organ that the animal is enabled to "shoot away like a fish." The creeping and crawling movements are brought about by peristaltic contractions of the body, something like those of a short worm. These movements are so characteristic that they have been termed "euglenoid."

The central portion of the endoplasm is coloured bright green owing to the presence of chlorophyll. This is said by Savile Kent to be assimilated, but Jeffery Parker states in his "Elementary Biology" that it acts in the same way as the chlorophyll of plants, which would hardly be the case unless the chlorophyll were developed by the animal itself. This green colouring matter is not invariable, and is stated on some occasions to turn to dark orange or red.

There is one contractile vacuole situated

anteriorly which opens into a reservoir, and in this part of the body also the red eye-like pigment spot or stigma is to be found. The nucleus is sub-central in position and possesses a well-marked nucleolus. Round it are arranged the highly refractive amylaceous corpuscles. These are composed of a substance known as amyllum, which is an organic compound built up of the same elements—namely, carbon, hydrogen and oxygen—united together in the same proportions as starch, but in a slightly different way. Amyllum does not form a blue compound with iodine, which is a reaction characteristic of starch.

Under certain conditions *Euglena* loses its flagellum, settles down to rest, and develops a coat of cellulose round it. If the conditions are favourable it emerges from this after a period of rest, and resumes active life again. Reproduction takes place either by the simple fission of the resting form, or by the formation of spores from it. In the latter case, when the cyst is ruptured, a number of small, green creeping things, like amœbæ are released, without mouth, gullet or flagellum. All these organs are gradually developed, and the adult form again presents itself to us. A third form of reproduction is described by Stein. This is brought about by the abnormal growth of the nucleus, which finally breaks up into numerous spores; these spores are liberated during the life of the parent as minute monadiform germs. A similar process of reproduction is described by the same authority as occurring in the genus *Trachelomonas*.

*Euglena deses*, Ehr.—This species differs from the last in shape, being not fusiform but cylindrical and very wormlike; it may be from fifteen to twenty times as long as broad, and when fully extended is acutely pointed posteriorly. However, it is very seldom fully extended, and is most often seen with one part of the body contracted into a lump. Ehrenberg, who was the first to describe it, affirms that this species never swims, but confines its movements to sluggish creepings and twistings.

It may be found in ponds overgrown with duckweed, but is never taken in such large shoals as is *E. viridis*. The length of the body is from 36 to 110 microns.

*Euglena acus*, Ehr.—This species almost might be said to represent the transition between *Euglena* and *Phacus*. Their "deportment in water" is, according to Savile Kent, "remarkably stiff," and they do not exhibit protean contractions and expansions like the other species of the genus. All this points to the fact that the cuticular surface is firmly developed, which, it will be seen, is one of the characteristics of *Phacus*. The body is slender and elongate, from seven to eight, to ten or twelve times as long as broad, tapering towards the

extremities. It is abruptly truncate anteriorly, and produced posteriorly into a sharp point; it is from 45 to 227 microns in length. The amylaceous corpuscles are numerous, and elongate and rectangular in shape. It needed no great flight of the imagination to call this animal "acus"; it truly resembles a needle, the posterior extremity forming a formidable point, and the contractile vacuole an excellent eye. It would take a skilled sempstress indeed to thread this needle.

*Phacus longicaudus*, Ehr.—The body is compressed and leaf-like in shape; the posterior extremity is drawn out into a sharp-pointed tail-like prolongation, which may equal the rest of the body in length; the cuticular surface is longitudinally striated and hard, but not so hard as in some of its congeners. A curious characteristic of this animal is the corkscrew-like shape into which it sometimes twists its body. This is not brought about by any sudden movement but by a very gradual process, which might possibly be due to an unequal rate of growth of the ectosarc. If this

were the case it would be analogous to the twisting of the tendrils of plants, which is effected by different parts of the tendril assuming in succession a more rapid rate of growth.

In other points of structure besides those above mentioned, *Phacus* agrees fairly closely with *Euglena*. I found *P. longicaudus* in greatest quantities in the dykes which drain the large areas of marshland which occur on the east coast of Norfolk. The length of the body is 52 to 156 microns.

*Phacus triquetter*, Ehr.—More or less closely resembles *P. longicaudus*, Ehr. It has a raised keel-like elevation produced down the middle of one side, its caudal prolongation is only about a quarter of the length of the body, and is obliquely pointed in an upward direction. It does not twist itself spirally like the last species. Length of body, 47 microns.

Its favourite habitat appears to be in ponds covered with duckweed.

(To be continued.)

## AFTER DARWIN.

BY G. W. BULMAN, M.A., B.Sc.

IT was, perhaps, but to be expected that with the loss of their captain the camp of evolution by natural selection, should be divided, and that each lieutenant should aspire to the rank of leader. Or, to speak more appropriately, it was only natural that spontaneous differences of opinion should arise, and that in the ensuing struggle for existence among these variations, certain should survive, and finally form more or less distinct theories. This is emphatically what has happened.

In a letter to "Nature," July 30th, 1896, Mr. Thistleton Dyer writes: "The result is that the Darwinian theory of organic evolution seems hardly to have a convinced supporter left except Mr. Wallace. In its place we have the 'Physiological Selection' of Dr. Romanes, the 'Discontinuous Variation' of Mr. Bateson, and, last of all, the extended 'Correlation Principle' of Professor Lankester."

Even this does not exhaust the list. We must add the Neo-Lamarckism of the Americans, and the Neo-Darwinism, or pure Natural Selection, of Weismann and others. Each thinks his own "improvement" does away with the difficulty which he naturally and rightly feels in the original, and no one else quite agrees with him. Still more naturally does Dr. Wallace hold to the older view as being his own. Yet even Dr. Wallace is not on all points an orthodox Darwinian. He has, for example, rejected sexual selection, which formed so important a part of Darwin's views, and upon

which he relied so much. Dr. Wallace would also bring in other factors in the evolution of the higher nature of man which Darwin did not acknowledge. Thus, even Darwin's co-partner in the theory of natural selection has diverged; and we may, perhaps, safely assert that there is no evolutionist of authority who has not wandered, more or less, from pure Darwinism—meaning thereby the Darwinism of Darwin himself.

The volume before me—"Darwin and After Darwin," part iii.—is an interesting example of the evolution of a new variety of the parent theory. This third part of Dr. Romanes' work deals with the questions of isolation and physiological selection. It is in some respects the most important, as it contains an account of Dr. Romanes' own contribution to the theory of natural selection. The author was led to formulate this hypothesis to supplement what he felt was the insufficiency of the theory of natural selection as understood by Darwin and others. This, indeed, is the explanation of most of the amended theories of evolution which have from time to time appeared. Their authors have all felt the difficulties of the subject as it stood, but all have found the holes in different places. So, each having put on his patch, refuses to see that the patch of any other is at all necessary. Their united testimony leaves scarcely a sound part in the original view. To the impartial onlooker each is more convincing when he is showing the weakness of another than when

enforcing his own opinion. Wallace's arguments against sexual selection show us conclusively its absurdity. His contention that natural selection is able to effect what Darwin attributed to sexual, fails to carry conviction. Weismann is infinitely more successful in proving that there is no transmission of acquired characters, than in showing how natural selection can do the work without it. Dr. Romanes carries us irresistibly with him when he proves that natural selection alone cannot produce divergent evolution. When he comes to his theory of physiological selection, which is to supplement it, we cannot follow him without protest.

The book begins by insisting on the extreme importance of isolation as a factor in evolution. Every naturalist has more or less recognised its importance, but the author thinks only he and Mr. Gulick have realised how important it really is. The principle of isolation is deeper and of larger influence than even natural selection itself. Heredity, variation and isolation form the three pillars upon which the whole superstructure of organic evolution is reared. By isolation is here meant anything which prevents intercrossing between one section of a species and the rest of that species. Dr. Romanes believed that "in the presence of free intercrossing natural selection would be powerless to effect divergent evolution."

"The point then," he insists, "which in the first instance must be firmly fastened in our minds is this: so long as there is free intercrossing, heredity cancels variability and makes in favour of fixity of type. Only when assisted by some form of discriminant isolation, which determines the exclusive breeding of like with like, can heredity make in favour of change of type, or lead to what we understand by organic evolution."

The difficulty here emphasised is one which has been felt and dwelt on by most critics of Darwinism, and has been replied to—but never, we believe, satisfactorily—by leading Darwinians. What is wanted, certainly, is something which determines the "exclusive breeding of like with like." We must, however, surely admit that every evolutionist has acknowledged the need for isolation, and the breeding of like with like. As regards this, indeed, it appears that the difference between Dr. Romanes and others is partly verbal and partly a question of the degree in which the various factors concerned have entered into evolution. How far, then, we may inquire, does Dr. Romanes' new view render the "exclusive breeding of like with like" more probable? Isolation in general is first of all treated, and two kinds are distinguished. Thus, if a shepherd divides his flock by placing all the white sheep in one field and all the black in another, or if in a certain species a change of instinct in a part of the

same determines migration to a new area, the isolation is *discriminate*. If, on the other hand, a shepherd divides his sheep without any regard to their characters, or if geological subsidence separates a species into two parts, we have *indiscriminate* isolation. Both these forms of isolation are potential in the formation of new species.

The reader who has got thus far in the argument wonders what has become of natural selection, and begins to feel that the charge sometimes brought against the author of having substituted physiological for natural selection must be true. But on page 9 we learn that natural selection is to be looked upon as a form of isolation, inasmuch as it kills off one part of a species, and thus isolates another.

We now come to physiological selection, another form of isolation, and obviously considered by the author to be the most important of all. Let us inquire, then, what physiological selection is, and to what extent, if any, it supplies the universal desideratum of evolutionists, a something which determines the "exclusive breeding of like with like." It is defined as "sexual incompatibility—either partial or absolute—between different taxonomic groups." Again, it is described as "that form of isolation which arises in consequence of mutual infertility between the members of any group of organisms and those of all other similarly isolated groups occupying simultaneously the same area." It interposes "the bar of sterility between two sections of a previously uniform species; and by thus *isolating* the two sections one from another, starts each upon a subsequently independent course of divergent evolution." As the starting-point of the theory, the fact that "some degree of infertility is not unusual as between different varieties of the same species" is brought forward. Thus we gather that the beginning of physiological selection is *some degree of infertility—some diminished fertility*—between individuals of a species. Does this theory, then, give us anything to determine "the exclusive breeding of like with like"? We must first ask, is such cross-infertility necessarily accompanied by disinclination to breed together? As far as we can gather, Dr. Romanes does not contend that the infertility of certain individuals with the parent stock necessitates an inclination to breed together rather than with the latter. Nor is there any evidence to show that this is so. Thus Dr. Romanes' theory is either inefficient or superfluous. For if infertility does not happen to be accompanied by inclination to breed together it will be eliminated, like any other small variation, by intercrossing; and if it chance to be accompanied by the same it is not required, for as long as the individuals keep separate infertility or increased fertility with the parent stock is quite immaterial. Thus, while it

seems to be absolutely necessary for the theory of physiological selection that the cross-infertile individuals should breed together and not with the parent stock, it seems to be no part of the theory that they necessarily do so, nor is there any evidence forthcoming from the facts of nature that such is the case. No one, we believe, has contended that the fact of potentially lessened fertility between two individuals would prevent them breeding together.

Again, we must ask, is cross-infertility of the requisite kind at all common? Different degrees of fertility are of course frequent; but does it often happen that an individual A is perfectly fertile with another B, and comparatively sterile with C, while C again is perfectly fertile with D? This is what would be required, but evidence is not forthcoming. Infertility between species and between varieties of the same species is brought forward, and this, in the eyes of some, is enough to prove the existence of the other. Again, Dr. Romanes tells us that: "The importance of physiological isolation, *when once fully developed*, cannot be denied, for it is evident that if such isolation could be suddenly destroyed between two allied species occupying a common area, they would sooner or later become fused into a common type."

Here Dr. Romanes does not seem to me to distinguish clearly between *infertility* and *disinclination* to breed together. Mutual fertility would not in itself induce two species to breed together unless the bar which at present prevents them even trying to come together were removed likewise. The difficulty in breeding mules is not sterility, but in overcoming the natural disinclination of the two species to come together. Infertility is not the reason why species do not attempt to breed together. There is disinclination, or some physical bar. Again, before any section of a species rendered cross-infertile can develop into a new variety there must be also change of form. Now when we look to our domestic breeds we find that great change of form has not been accompanied by infertility. Hence we must suppose it a mere coincidence if cross-infertility in nature is accompanied by departure from the normal type. This makes difficulties for physiological selection. In the first place, the cross-infertility and mutual fertility has to appear simultaneously in a number of individuals. Before a new species can arise there must be outward variations among these, not indiscriminate, but at least preponderating in the direction of the characters of the new species. Further, if divergence of type, as in the domestic breeds, is not necessarily accompanied by infertility, neither can we assume that infertility is likely to be accompanied by divergence.

Again, sterility eventually arises in cases of geographical isolation, yet was not the cause of the

isolation or differentiation. Dr. Romanes, indeed, hints that species separated geographically will be found to be more frequently cross-fertile than those living together. No proof of this, however, is given. Darwin's opinion on this point was given thus: "Species which have never co-existed in the same country, and which therefore could not have received any advantage from having been rendered mutually infertile, are generally sterile when crossed."

What positive evidence, let us now ask, does the author bring forward in support of his view? It must be confessed that what is offered is neither very abundant, nor very conclusive. It is, moreover, of an indirect kind, chiefly consisting in this, that certain facts are more easily explained by it than on the assumption that natural selection has been the sole factor in species making. Thus, the fact that large areas are better manufacturers of species than small ones is a difficulty without physiological selection, on account of the swamping effects of intercrossing on such larger areas. Darwin, by the way, explained this by the fiercer competition. Again, the fact of closely allied species living together is claimed to be more in accordance with physiological than natural selection.

Touching Nägeli's examples of closely-related plants growing in close proximity, Romanes writes: "But now, if this bar is thus necessary for preserving the specific distinctions when they have been fully developed, much more must it have been so to admit of their development." Yet when the bar was *most* necessary it was feeblest! The bar is necessary to separate them, and yet it can scarcely be said to exist until they are separated.

Dr. Romanes points out that on his theory varieties ought to show cross-infertility, whereas the theory of natural selection has no reason to anticipate such a state of things. As to fact, many varieties of plants are found growing close together, and yet retaining their independence. For evidence of the actual existence of such infertility Dr. Romanes quotes only the experiments of M. A. Jordan. This French observer found that in many hundreds of cases varieties came true to seed, and were cross-sterile *inter se*. Even with all this evidence, it remains an assumption that the sterility was the cause of the variations. Can we, moreover, accept the evidence given above as proof of general sterility between varieties? It is from a single set of experiments made some twenty-three years ago, and there must surely be much more evidence available for or against the view. Moreover, as Dr. Romanes tells us, the experiments were made with a special object in view, *viz.*, to prove that all such varieties were separately created species. On the other hand,

it was one of Darwin's conclusions from his experiments on cross-fertilization, that crosses between varieties are more vigorous than others. Thus, with regard to plants, he remarks: "I suspect that it must arise from the pollen of a distinct *variety* having a prepotent effect over a flower's own pollen."

This, however, applies to domesticated species, and Dr. Romanes believed that there is a difference between these and natural species in this respect. It would be strange if variation among domestic species were normally accompanied by increased fertility, while in nature it went hand in hand with infertility.

The great difficulty in physiological selection seems to be a variant of the problem, how the horse is to feed while the grass grows; or, how a variation can be preserved and fostered by natural selection while too insignificant to be useful. How, that is to say, is the new variety to be kept separate while the bar of sterility is being forged from some slightly diminished cross fertility?

If a number of individuals in a species could be assumed to acquire at once an absolute sterility with the rest, and retain perfect fertility, *inter se*, then we might accept physiological selection as a *vera causa* in the evolution of species: a small degree of cross-infertility is useless.

Another point in which Dr. Romanes seems to differ from other Darwinians, is in believing that isolation alone can produce divergence when a small part of a species is separated from the rest. The mean or average character of the separated portion, differing slightly from the remainder, will, when cross-breeding has reduced it to uniformity, have diverged a little from that of the parent stock. Such being the case, we should expect to find small isolated colonies of a race varying from the main body. There may be examples to support this view, but there are certainly an overwhelming number against it. For example, a number of colonies of Arctic plants are found on the higher mountains of Wales and Scotland, where they have been separated from the main bodies of their species since the close of the Glacial period. Similarly isolated colonies of butterflies are also known. Most interesting is the case of a beetle, *Chrysomela cerealis*, found on Snowdon, and nowhere nearer than the cornfields of France. Again, we have the case of the rabbits and sparrows imported to Australia and New Zealand, and English weeds introduced into America, all in small numbers, and all without any indications of the formation of new species. The colony of South European plants in the south-west of Ireland, and of many aliens and colonists in England, are further examples. Indeed, as we reflect, the adverse cases come crowding in upon us—they are without number. Dr. Romanes himself, with

Darwin-like candour, brings forward several interesting examples which he admits are against his view.

Wallace, in criticising Romanes' theory, quotes the case of Ireland as showing that isolation has not produced divergence of species as it ought, if it were a *vera causa*. Ireland, he says, furnishes "an excellent test case, for we know that it has been separated from Britain since the end of the Glacial epoch . . . yet hardly one of its mammals, reptiles or land molluscs has undergone the slightest change." To this Dr. Romanes replies that Ireland is not an excellent test case for the efficiency of indiscriminate isolation as a factor in evolving species, since the potency of isolation varies inversely as the number of individuals separated. When Ireland was severed from Britain there were too large numbers of the various species in it to allow of divergence from the parent type. Such is the answer. If we want a good test case we must choose one where only a small number of the species have been separated. Yet if we were to refer to the various small islands off the coast of Britain where species have long been isolated in small numbers, we should, presumably, be told that they were too near the shore. We finally gain the impression that the places where species can be manufactured are few and far between, if not actually *in nubibus*.

Whether Ireland be a good test case or not, we must be permitted to say it comes a little strangely from Dr. Wallace. For surely on his own views, equally with those he is criticising, there ought to be divergence of species in Ireland. There is difference in environment. For the climate is not the same; there is a difference in the assemblage of animals (absence of reptiles, etc.) and of plants (presence of foreign species, and absence of others occurring in Britain), while the soil on the whole is also different. The reason for the lack of change is given by Wallace as follows: "That changes have not occurred through natural selection is, perhaps, due to the less severe struggle for existence, owing to the smaller number of competing species."

If there had been changes, would not Wallace have claimed them for natural selection? Ireland seems, indeed, an excellent test case for the theory of natural selection in general. For if in the period of 80,000 years which some tell us have elapsed since the close of the Glacial period, it has done nothing, how could even the millions demanded by geologists and biologists be held sufficient to evolve the organic world of to-day?

There are, says Dr. Romanes, two great difficulties for the theory of natural selection. First, natural selection alone can only lead to monotypic evolution, that is, it can only gradually modify one species into another: it cannot split up a species



into two or more. Some form of isolation is required to do this. The second great difficulty is the contrast between the fertility among artificial varieties, and the sterility between natural species. It is claimed that these difficulties are done away with on the new view.

The thing, then, which Dr. Romanes has most clearly proved is that divergent evolution is a logical impossibility without some form of isolation. This had already been done by many critics of Darwinism, and must indeed be evident to all thoughtful minds. It is doubtless the feeling of this insufficiency which has led to the many amendments to Darwinism which have from time to time appeared. When, however, we come to Dr. Romanes' method of supplementing natural selection, we cannot follow him so easily. The swamping effects of inter-crossing are convincingly dwelt on; but, one asks, does not this swamping tell equally against the new theory? For the cross-infertility is but a variation beginning in a small way, and as such, amenable to the laws of variation, viz., in the presence of free inter-crossing to be absorbed. As far as one can see, there is absolutely nothing to prevent free intercrossing. Thus, while Dr. Romanes has doubtless made a formidable breach in the walls of the theory of natural selection as usually held, he has not, in my judgment, succeeded in repairing the same by the props of physiological selection which he has inserted. He has, however, defended his position in his usual brilliant style against all comers. It would be *Athanasius contra mundum* if it were not for his *fidus Achates*, Mr. Gulick, for no other evolutionist accepts his views. And

having hit out with force and precision all round, we have at the close of the book, as is fitting, the handshake of the opponents. Readers are requested to note how great, in spite of the noise of conflict, is the solid agreement of evolutionists on all really great questions. Whether the reader will be convinced of this solid underlying agreement in spite of apparent discord, seeing that each owner of a theory clearly proves that to be impossible which the other demands as essential, will be a matter of individual taste and bias. When, for example, Weismann proves as rigidly as scientific proposition has ever been proved, that there is no transmission of acquired characters, and considers that natural selection alone has done all the work in the evolution of species, while Romanes deems it absolutely necessary that it should be supplemented not only by such transmission, but by physiological selection as well; and the Neo-Larmarckians in America deem necessary more transmission of acquired characters than even Darwin assumed; and Romanes proves conclusively that without physiological selection, or other form of isolation, there can be no divergence of species, while Wallace and others contend that there is no such thing as physiological selection; when certain Darwinians, as did Darwin himself, consider that sexual selection is an essential factor in the making of species, while Wallace and others have discarded it and shown it to be absurd; there surely seems room for difference of opinion as to the solidity of the agreement.

*Jesmond, Newcastle-on-Tyne.*

## FIGHTING AN INSECT.

IT was not until the year 1869 that the gipsy moth (*Porthetria = Liparis dispar*) was known to have been colonised on the American continent. Like some pests in other parts of the world, it appears to have been introduced through the enthusiasm of an admirer. This act has been attributed to Prof. L. Trouvelot, a naturalist and astronomer, who was at that time connected with the Harvard University. In his case it was not so much any especial admiration for the species as that he required it during certain experiments with silk-producing moths, having the object of producing a hardy hybrid which would withstand the exigencies of climate and the attacks of fungoid or other enemies.

Twenty years later it was found that combined effort for the reduction of the plague of gipsy moths was necessary in the town where the Professor had introduced them. This was in

Medford, near Boston, Massachusetts. There seems to be no doubt that Prof. Trouvelot realised the danger of the caterpillars escaping, for when the catastrophe happened he at once gave public notice of the fact, and did all possible to repair the mischief. It was, however, too late; though no signs were seen of either moths or their larvae for many years, the time came when the latter were stripping off the foliage of most of the ornamental and shade trees throughout the region. In a report upon the whole question, which has been recently prepared under the direction of Prof. L. O. Howard, the Entomologist to the United States Department of Agriculture, the slow progress in the establishment of this species in America is attributed to the time required for it to adapt itself to the severe climate. It took from fifteen to twenty years for the gipsy-moth to become abundant enough to command the

public notice which led to the concerted action for its destruction. The first grant was one of £60, an amount then thought sufficient to cope with these little pests. This did not nearly represent the total spent, for added to it were the sums expended by individuals on their own shade trees. Men were employed all through the following winter to scrape off and destroy the egg clusters which thickly hung on the trees. This modest sum was found to be useless, for since that period, or, more correctly, during the past nine years, no less than the immense total of £150,000 has been expended, with the result that the pest is slowly but surely increasing its radius of occupation.

As in Europe, the gipsy moth in Massachusetts produces but one generation each year. Each female, however, deposits from 400 to 500 eggs, which are attached in clusters to any convenient surface, such as the twigs and trunks of trees, to stones, or to logs lying within easy reach of the food trees. Unfortunately, these clusters are often placed in crevices, and are frequently overlooked by those employed in finding and destroying them. They remain in the egg state for nine or ten months, the larvae hatching at intervals from the end of April to the middle of June. In the caterpillar stage they feed for about ten weeks, during which time all the mischief is done. They are most active at night, and appear to feed in America on nearly every native and introduced plant of importance.

The Economic Entomological Department of the United States is so well organized, and so experienced in dealing with the great damage done by insect pests, that we have no doubt every effort is being made to control this serious visitation. The use of chemical insecticides is there so well understood that enormous quantities of the caterpillars are killed by spraying the trees with arsenical solutions. This spraying is accomplished by steam-engines especially constructed for the purpose, and by their means the highest branches of the tallest trees are reached. In the forest lands the underwood is cut away and is burned over the ground. Gangs of men are employed in searching all over the trees and the bushes for the egg clusters; this seems to be one of the most successful means of reducing the numbers of these destructive caterpillars. Burlap bands are placed round the tree trunks, which intercept the caterpillars from returning up the tree trunks when they accidentally fall to the ground, or are hatched there. These bands are covered with a viscid sticky substance, such as tar or fish oil. In destroying the eggs the burning must be conducted with fierce heat, for they easily resist a passing flame, in consequence of the hairy covering of the egg mass being an excellent non-conductor of heat. Thus an ordinary bush fire appears to

do them little or no harm. The most effective destroyer of the egg masses appears to be to thoroughly paint each egg mass with creosote oil. It is quite surprising how expert become the men who are trained in the discovery of eggs. They will see them instantly, even at the tops of trees, where they would be quite unnoticed by the uninitiated.

Although such a large sum has been spent upon fighting this insect, we imagine very much more has yet to be done; and it appears probable that now the gipsy moth has become so thoroughly acclimatized, it will spread further on the North American continent, in spite of all efforts for its restraint.

This species has caused considerable trouble in some parts of Western and Central Europe, where it is abundant. In Britain it used to occur in the eastern counties, but it is doubtful whether any native specimens have been taken in this country for nearly half a century. For some reason, probably climatic, it disappeared, and entomologists who pride themselves upon having only British specimens of butterflies or moths in their collections will readily pay as much as £1 for each well authenticated individual which is known to have been taken here by some old collector in times gone by.

Ardent collectors have often tried to re-establish the species in Britain by the introduction of continental European eggs or caterpillars; but fortunately have hitherto failed in the attempt. The expert English lepidopterist will readily point out the difference between Continental examples of the gipsy moths and those of the old English race which has disappeared. These were larger, more robust, and of a different tint in coloration.

DESTRUCTION OF EARTHWORMS IN ESSEX.—The great storm of November 28th last on the Essex coast did immense damage by bursting sea-walls and flooding upwards of 50,000 acres of agricultural land. The cost of repairs of these banks is not the only loss. In a report which has been prepared by Mr. T. S. Dymond, Staff Lecturer on Chemistry to the Essex Technical Instruction Committee, on the results of the inundation of sea-water, he states that the ordinary percentage of salt in the soil is .01 per cent, but on the flooded land it has risen to .20 per cent. This amount of salt is equal to two tons per acre. Some crops have suffered severely, peas and tares especially, and wheat has likewise died off, but to a lesser extent. The most serious result of the flood of salt water has been the killing of the earthworms, which were found dead in multitudes on the surface of the fields when the water subsided. Sea-gulls greedily fed upon them, and soon carried them away. These worms will be a great loss to the farmers, for they assist largely in promoting the drainage of the fields and relieving their sodden condition.

## ORCADIAN RAMBLES.

BY ROBERT GODFREY.

*(Continued from page 287.)*

## V.—KIRKWALL TO TANKERNESS.

LEAVING the town by the road that runs between the Cathedral and the Earl's Palace, on May 31st, I kept the telegraph-lined highway till I had passed the headland that juts out to Holland. The country traversed presented a series of dissolving views, each passing into the succeeding one before its own beauty had completely gone, and the everchanging novelty of the landscape maintained the interest of the traveller. Each tract covered contained its distinctive wild life also; but could not, by a consideration of such, be divided by definite lines from adjoining tracts. Ere we leave the sparrows and the jackdaws behind us, we are listening to the carolling of the larks or the ceaseless craking of the corncrakes, and we are accompanied by these in their turn even after we have invaded the breeding-haunts of peeweeeps, redshanks and ring plovers.

I descended to the hollow skirting the head of Inganess Bay, and after crossing a small burn that there gains the sea, I turned along the southern shore of the bay. Pied wagtails were very obtrusive, and evidently feeding young, though they would not go to the nest whilst I waited, and a single twite was singing on a telegraph-wire. At this part the shore of the bay was a low, sinuous, grass-clad bank, behind which, with only a narrow breadth of pasture between, lay the cultivated ground, and on the occasion of my visit the sea was calm and smooth, and broke in a gentle whisper on the flat rocks. Rock pipits were the prevailing bird-life here, and flitted about from rock to rock in restless excitement, carrying food in their bills the while. Two eider drakes were the first birds observed on the water, and a duck, disturbed by my advance, swam away from land and joined their company. A third eider drake appeared further off, and repeatedly thereafter the characteristic subdued moaning of this species reached my ear. A common cormorant, too, rose and flew to a more distant position, and a single seal, far from the land, delighted me by its silent appearances and disappearances, leaving no ripple on the surface to tell where it sank.

The shore became more level and the cultivated land rose but little above high-water mark. It was still divided from the shore by a narrow path only, covered with abundance of white daisies. In one part a large nettle bed flourished, and near this I roused a beautiful dark-red butterfly, which seemed to me rather out of place in such a locality.

On finding my pursuit to be vain, I turned my attention again to the birds. A group of peeweeeps passed out seawards and returned, and a starling rose from the beach, whilst a ring plover ran along the shore before me. Presently a mallard drake rose; a little further on a widgeon drake in brilliant plumage appeared near the shore, and an unknown duck flew off. Here an Arctic tern and a cormorant also came under my notice. The place had suddenly become alive with a fine variety of birds, and I knew that all my silence and patience would be needed. Presently the strange duck returned and alighted near the widgeon, but did not associate with it; it was smaller than a widgeon, and resembled a shoveler, but had not sufficient white on the plumage. Further off shore a pair of mergansers were swimming—the drake a most handsome bird—and, without warning, a seal appeared amongst the seaweed close at hand, and tore through it at a fearful rate. My little duck had gone, I knew not whither, and I had failed to identify him. In the absence of wind the day was close, but the bright sun revealed everything in its fairest form, and the calmness of the sea rendered observation easy. One cannot help himself in the midst of scenes like these; one loiters on in happiness, forgetful of all else in the pure joy of nature, lingering willingly amidst such enthralling delights, and with difficulty tearing oneself from the siren spell that keeps one bound.

Where the roadway diverges from the sea, some rough ground lines the succeeding stretch of shore, and here ring plovers, with gentle call, kept reproving me for my trespass, whilst occasionally an Arctic tern or a peeweeep would excitedly call overhead. I found a dead merganser drake, and saw a few eiders, but did not again meet with the stranger duck. On passing round the low-lying headland I came to a shallow arm of the sea with a narrow entrance, and halted at the mouth, on the other side of which a long, narrow, stony point runs landwards, creating the barrier that nearly forms an independent loch. On this stony neck of land the Arctic terns had evidently a colony, as they kept up a constant flutter of excitement over the point where their eggs undoubtedly were. The dark under-plumage of the birds and the more continuous call-note helped to distinguish the species, but I waited till two alighted on seaweed-covered rocks beside me to

preen their feathers, and I then saw accurately their blood-red bills. A party of four oystercatchers were also frequenting this neighbourhood, but did not betray great excitement, and a sandwich-tern in the air drew my attention by its distinctive call-note. A dunlin rose from the beach and flew to the seaweed, and I anxiously, but unavailingly, searched for the eggs amongst the stones and gravel, never having yet found them in such a site. The little bird fed most confidently on the shore, and called once, whilst ring plovers ceased not to call plaintively about me. When eventually an oystercatcher uttered its alarm the interesting little party flew off.

A lengthened detour was necessary to reach the stony point, and the walking over the raised line of smooth, rounded stones, running out about a quarter of a mile from land, was of a very rough nature. Towards the extremity of the point, grass, with scurvy-grass, clothed the stones and made a softer surface, and at the region immediately before this, where scurvy-grass and *Silene* were struggling to maintain their hold amongst the stones, the Arctic terns were chiefly breeding. The first nest found, consisting of a few thin stems placed together in a slight depression, contained two eggs; a second nest, marked by a line of seaweed round its rim, lay a little off amongst some stones, and contained three eggs, and another amongst stones was formed of a considerable mass of seaweed. The birds were just beginning to lay, as I found only one nest with three eggs. I failed to find the eggs of the sandwich tern, and doubt whether it was breeding at this point. The only birds present here, besides the Arctic terns, were a pair of rock pipits that frequented a ruined circular dyke in the terns' haunt.

Continuing my journey along the grassy fore-shore, I renewed my acquaintance with many species already noted, and observed a single black guillemot. A sudden change to moorland, however, takes place, and persists as far as the next headland, where a series of rocks of no great height—though steep, and forming two fine geos—forms the corner of the headland. These combined aspects of wilder scenery encouraged the hope of some change in the bird-life. The summit of the rocks was finely decked with the beautiful blue *Scilla verna*, and masses of *Empetrum nigrum*, covered with a thick crop of still unripe berries, formed mats near the edge. Peewees and ring plovers still remained constant to their charge, and the golden plover now awaited me and called from his station on the ground. From the rocks I roused a pair of rockdoves, and I also found a pair of hooded crows tenants here. One new nest of the latter birds occupied a depression near the top of the rocks, but the eggs had been smashed by stones dropped upon them from above; nevertheless, the

uproar of the birds assured me that they had another nest in a securer spot. The other rock birds here were cormorants—four of which passed together, and an odd one later—also a single black guillemot. Once a nestling rock pipit issued from a mass of crowberry and disappeared over the banks. The rocks soon failed, and a small loch lying in the following depression again afforded a change of scene. A goodly number of birds found food or shelter on this loch and on the adjoining swampy ground. On my approach eleven oystercatchers flew off in a body, and a single shelduck made seaward, whilst a dunlin—most confident of birds—ran anxiously along the edge, as if intent on feeding only. Two other dunlins were here also, but their mates may have been sitting far enough away from the water. Two herring gulls—one immature—hovered for a long time overhead. The surrounding swamp was rough, and suitable for nesting-birds, but, as I had yet so much ground to cover, I could not spare the necessary time to explore it.

Striking across country, with peewees and a pair of redshanks attendant, I disturbed a lark from her nest, with four eggs, in a thick bunch of heather, and soon after I reached the side of Tankerness Loch. I was in great hopes of finding something worthy of note on this extensive sheet of water, nor was I disappointed, though my first scrutiny of the surface gave me little encouragement. I observed some ducks not favourably situated for identification, and meanwhile paid no further heed to them, as I hoped to have a distinct view of them from the opposite side of the loch. Beginning my circuit of the loch—keeping it on my right hand—I loitered long about a great patch of heather that was enclosed between the water's edge and a semicircle of bright golden whins. Here a number of small birds—yellowhammer, common linnet and starling—found shelter, but no ducks rose from their nests in spite of my persistent search.

The heather ground gave way to pasture and cultivated land, and my old assailants, peewees and redshanks, with ring plovers and Arctic terns, again attended me. My journey to the loch head did not reveal anything of interest, and I had turned along the opposite side before I began to encounter the typical life of the loch. Three mallard in down presently ran to the water's edge and swam off from land, and, on my crossing to the spot from which they had risen, the old bird fluttered out. She beat back and forward in front of me, with her neck stretched fully out along the surface of the water, whilst the young birds swam out far from shore. The mallard duck remained near the edge, displaying her anxiety in a most marked manner, and kept flying in front of me long after I had left the spot where her young had

lain. On tramping through a patch of flags, I roused another mallard and saw two youngsters lying perfectly motionless at my feet. I made a sudden dart, causing them to take alarm, and catching one of them, held it for a moment, then allowed it to hurry after its mate to the water. I thought from the conduct of the mallard that she had more young about, but I saw two only.

Near the boathouse a corncrake that had been lying up amongst long grass rose hurriedly from my feet, and passing round the boathouse returned again to land. Amongst some rushes a little ahead of this point I noticed a waterhen's nest with five eggs on the point of hatching, and by carefully beating the rushes I disturbed one of the birds. I was so intent on examining the rushes and growing flags that I allowed the ducks on the water, still unidentified, to cross to the other side of the loch, and I saw that I should have to wait for their approach, unless indeed I wished to make another circuit of the loch. Accordingly I rested by the loch-side to await their return, and was meanwhile amused by the antics of a little grebe that was making sudden darts through the water and apparently catching insects—a habit I had not previously noted in this species. After long delay I found it necessary to move again with the sun, and journeying on round the loch I roused some dunlin and noticed another mallard with young, and eventually reached a spot from which I could identify the bird-life. Near the edge a party of ten mallard drakes were resting, whilst the other species kept out in the middle. These latter included a pair of mergansers that repeatedly flew up and down excitedly calling; a single widegeon drake, whose mate was no doubt sitting; and, best of all, two pairs of scaups. The last-mentioned species was, of course, by far the most interesting, and claimed the remainder of my time. It seems strange that, after so many instances of the scaup's lingering on into summer with us, have been recorded, the nest has not yet been found and properly identified in Britain.

With the identification of the loch's tenants completed, I considered my day's work finished, and setting out for home once more, I easily covered in less than two hours the distance that had taken nearly five times as long by my curious method of procedure on my outward journey

*To be continued.)*

**FASCIATED ROSE-STEM.**—I forward you a specimen of fasciation from a red rose bush in our garden. The pieces will all fit together and measure about 31 inches in height. There is little or no indication at the base of the stem that four or five shoots were enshrined in one cortex, as you will note that the radical end is almost as round as a normal shoot—(Rev.) R. Ashington Budden, F.G.S., Loughrigg, Somers Road, Keigate

## ANTS AND APHIDES.

**M**R. J. C. GOUDIE contributes to the February number of the "Victorian Naturalist" a note of much scientific interest, with regard to the association of ants and aphides. The interest is in the fact that ants in the Antipodes behave much in the same manner with regard to the aphides as do those of the continents of the northern hemisphere, thus indicating the common origin of this class of insects on the island continent of Australia and those of the Holarctic regions. The following is the note referred to:

"A small species of ant, commonly distributed in the Mallee, has a curious habit of keeping in close confinement a rather large mealy aphid, which feeds on the stems of young eucalypts. Round and over these aphides the ants construct a domed covering of particles of bark, grass, etc., which serves the double purpose of imprisoning the aphides and excluding other ants. Some of these coverings appear to be entirely closed, while others have an opening left in the edge; this doorway is, however, constantly guarded by a pair of ants, which continually move about in the open space and seem much impressed with the importance of the duty assigned to them. Each enclosure contains generally from three to a dozen aphides and about the same number of ants. Upon making a breach in some of these structures, for the purpose of observation, I have noticed that many of the 'live stock' were immediately seized by the ants and forcibly removed to a place of safety.

"The ant under notice is about a quarter of an inch in length, and is of a uniform dark reddish-brown colour, and forms its ordinary habitation under logs or in old rotten stumps, and sometimes in the ground. Several other species of ants are very assiduous in their attendance on the various aphides, Tetigonidae and coccids, but the above is the only kind I have noticed that uses such extraordinary means to secure a monopoly of the much-prized 'honey-dew.'"

I am not aware of any European species of ant which, like those above described, build what might be termed a "cowhouse" in which to keep their captives.

F. WINSTONE.

**ROYAL INSTITUTION.**—The following are the science lecture arrangements after Easter:—The Right Hon. Lord Rayleigh, F.R.S., Three Lectures on "Natural Philosophy"; Dr. E. E. Klein, Two Lectures on "Modern Methods and their Achievements in Bacteriology"; Mr. J. A. Thomson, Two Lectures on "The Biology of Spring." The Friday Evening Meetings of the Members will be resumed on April 22nd, when Mr. W. H. M. Christie, the Astronomer-Royal, will deliver a Discourse on "The Recent Eclipse"; succeeding Discourses will be given by various lecturers of eminence.

## ROYLE'S BALSAM.

BY CONSTANCE GARLICK.

THIS plant, first described by Dr. Royle, in 1839, in his "Botany of the Himalayas," was brought to England some time between that date and 1850, and is now what gardeners would call a troublesome weed. It is even making its way in waste ground near houses, and may soon be counted a member of our alien flora. Somewhat surprising is it that a plant from Cashmere, which flourishes at an altitude of 6,000 to 8,000 feet, should be able to make itself perfectly at home in the smirched and shaded English suburban gardens. Indeed, it more than makes itself at home, for it is so successful an aggressor that our present point of view is how to get rid of it. If Royle's balsam were a tender annual how much we should admire it, but just because it is so easy to have it in plenty, and almost anywhere, we are apt to neglect our opportunities of observing an unusually interesting subject.

This balsam is indeed a plant of many devices, and it works indefatigably throughout its short, active life, from the time the sturdy seedling takes one by surprise as one goes round the garden some fine February day, until, in October, the brave flowers at last dwindle and pale before the night frosts. It has then done its work, having thrown its seeds far and wide for fresh conquests next spring.

The early start of the seedling in the race is an important factor in the plant's success, as it holds the best chance of space and sunlight against later comers. The stem grows very quickly in height and thickness, commonly reaching six feet and more. Dr. Royle speaks of the plant as "this gigantic species." The whole branch system forms a cone, giving a grand appearance of stability to its really cheap structure. How large a proportion of the fabric is water will be seen when one tries to burn the haulms in autumn. Neither time nor material were used beyond the requirements of an annual stem. The roots do not run far down into the soil. Perhaps it has not much depth of earth in its native highlands, but secondary roots are very readily produced from the base of the stem. If from the wind or any other cause, part of the stem lies along the ground, roots burst out from the nodes and form an additional support. From this point, as a new start, the stem grows vertically.

The leaves have a strong vein parallel to the margin, and it may be owing to this that the blade is so seldom torn. It is even more remarkable how free are the leaves from the ravages of caterpillars, those autumn pests of suburban gardens. The whole plant has a peculiar resinous smell, only slightly disagreeable to us, but judging by its

repellant effect on larvæ it must convey to them acute feelings of dismay and disgust. The hairs which fringe the leaf-stalk to its base are as efficient as a barbed-wire fence against intruders by way of the stem. The leaves are in alternating circles of three. If their position be remarked at noon and again at dusk, it will be seen that they have moved from a horizontal to a vertical position so that the leaves of each circle face one another. Loss of heat by night radiation is thus minimised, and it must be a very valuable saving in the high altitudes of Cashmere, where the difference between day and night temperature is so great.

The plant begins to blossom in July, and between then and October produces an immense number of flowers; very few of which fail in their object of setting seed. To attain this, the flowers must have winged visitors, since the pollen is shed before the pistil of the same flower is mature. The plant puts forth attractions which secure the services as pollen-carriers of English bees, both wild and from the hives. The pyramids of purple-pink flowers are visible from afar, while the peculiar smell before mentioned seems to be an indifferent matter to honey-gatherers. For their convenience of entrance the flower hangs from its slender stalk so as to offer a horizontal landing place, two petals of peculiarly irregular shape forming this stage. On this the bee stands firmly. Overhead is the cluster of five anthers joined in a ring. We will suppose these to be in the pollen-shedding stage; the bee is thrusting her way to the far end of the calyx-pouch where the honey is, a spot marked by converging streaks of colour. The insect forces apart the two petals on which it stands, widening and flattening the flower in such a way as to press the dusty anthers on its back. The exit is amusing to watch. A humble-bee has no choice but to back out, and at last makes a bungling drop into space, while a slimmer and perhaps more intelligent species of bee comes out head first through one or other of the two openings between the calyx and the two lower petals. In either case, the bee emerges well dusted with the pale yellow pollen. If the next flower visited is at the later stage in which pollen-shedding is over and the pistil is mature, the bee will put the pollen on the stigma which now projects where the stamens were before, and cross fertilization is attained.

The fruit is soon ripe; it looks tense and glossy, slender at base and top, five-ribbed, and red on the sunny side. When ripe, if touched however lightly, it bursts in a surprising manner. The five ribs are the middle lines of five strips; these separate from

the base and from each other, curving with great energy, not strictly like a watch-spring, in that they do not lie from base to tip in one plane. The base of each valve, as it curves rapidly upwards, wrenches the seeds from their points of attach-

ment to the placenta, and in so doing gives them a strong impetus outwards. If the coils of the valves were flat and not obliquely wound they would often involve the seeds instead of giving them, as they do, an oblique push outwards. It

may also be observed that the seeds do not hang vertically from their stalks, but a little sideways, so that when pressed upwards they can more readily yield. The strong, rigid curve of the separated valves shows what tension exists in the

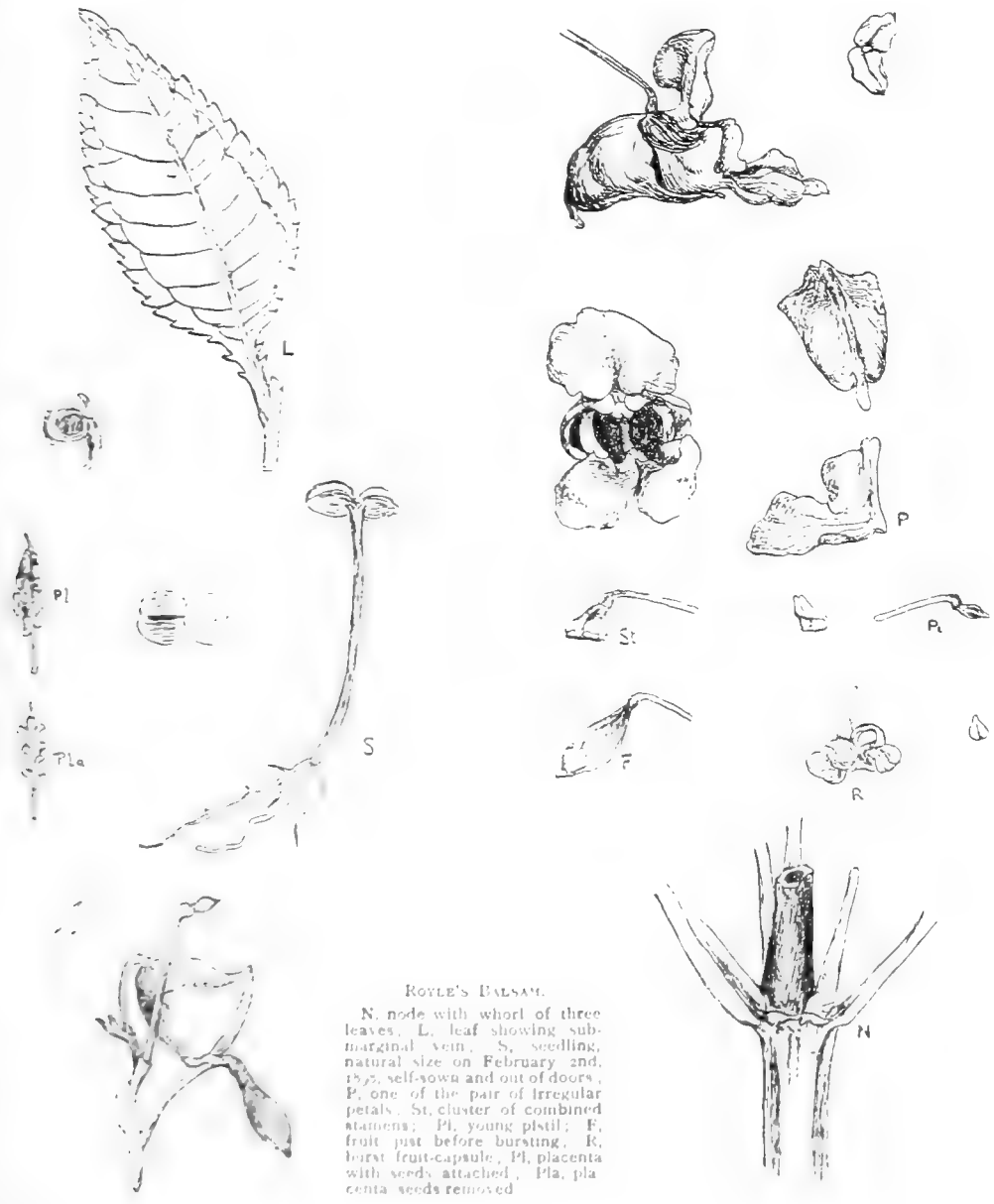

ROYLE'S BALSAM.  
 N, node with whorl of three leaves, L, leaf showing sub-marginal vein, S, seedling, natural size on February 2nd, 1872, self-sown and out of doors, P, one of the pair of irregular petals, St, cluster of combined stamens; Pl, young pistil; F, fruit just before bursting, R, burst fruit-capsule, Pl, placenta with seeds attached, Pla, placenta seeds removed

ment to the placenta, and in so doing gives them a strong impetus outwards. If the coils of the valves were flat and not obliquely wound they would often involve the seeds instead of giving them, as they do, an oblique push outwards. It

ripe fruit, but so long as the tip and base of each valve are in place they obviously cannot curve. The separation from the base of the fruit, however, brought about, allows the tendency to free play

11 Well Road, Hampton, N.W.

## THE EVOLUTION OF THE ANIMAL CELL.

By JOSEPH SMITH, M.R.I.A., F.L.S.

*(Continued from page 290.)*

THE processes, explained in the last portion of this article, which a complete cell in the tissues of the fully-formed animal undergoes in the struggle for existence, present a very interesting feature in the disposal of the worn-out material. The absorptive and eliminating power of the protoplasm is in affinity with the process, which, however, is a feature of the adult cell amongst fully-formed individuals, and may be well understood from a perpendicular section from some portion of the human body. "It must be remarked that in equal bulks of the tissue there is a larger quantity of the germinal matter in the lower part than in the upper part, which is a long distance from the nutrient surface, and that the converse is the case as regards the formed material which gives to the tissue its properties and physical characters" (1). A feature worthy of diligent attention is the apparent increase of the cells as they progress, until about a medium distance is arrived at, when from that point they noticeably diminish. While again, "the distance between them increases on account of the increased formation and accumulation of formed material; so that by the time the cells have reached the surface the distance between the masses of germinal matter is reduced again by the drying and condensation of the formed material" (1\*).

The changes which the living cell passes through may be briefly considered to be at the base, and in close contact to the nutrient surfaces are "masses of germinal matter embedded in a soft mucus-like and as yet continuous formed material." The germinal masses divide, and each absorbs some of the surrounding mucous mass to compensate the matter thrown off in the oldest cells. Each mass continues to increase in size according to the quantity of nutritious pabulum absorbed, which passes through the stratum of formed material, a portion of the germinal matter undergoing during the process conversion into formed matter, which accumulates upon the surface within that already formed. As each new layer is deposited upon the surface of the germinal matter, those layers of formed material are stretched, and with them the last developed are more or less incorporated, the germinal matter increasing for a time while the newly-formed matter is evolved. Now, as progress is made, the new cells being produced below matter which has thus been formed, it—the matter—is gradually removed further from the nutritious and vascular system, and consequently as the material

so formed becomes older, it is less sensible to the process, assuming on that account a harder nature, which makes it less permeable to the nutrient elements, and from this point it ceases to increase in size. Germinal matter decreases on account of its conversion into the solid or formed material which results; hence the further it—the material—is from the nutritious germinal surfaces, the less benefit does it derive from the surroundings, because of the impotency of the harder and denser mass to absorb pabulum in corresponding ratio. The result is that the germinal matter—the nucleus—becomes smaller in old age, so that eventually the element of germinal matter left unconverted into formed material, being unable to sustain life further, dies, and the cell having arrived at the surface is cast off, a "mass of perfectly passive, lifeless, formed material."

The peculiar substance which constitutes the bodies of unicellular organisms was named (2) "sarcode" on account of the mechanical or irritable movements which it was capable of undertaking, and which gave rise to the assumption that the sarcode was a differentiated material. This assumption induced many naturalists to endeavour to demonstrate the structure of the sarcode to be a combination of many cells, with the view of bringing this material under, and including it in, the cell theory (3). Cohn was the first to compare the sarcode with the protoplasmic contents of the plant cell, consequent on his observations on the similarity of vital phenomena, and these observations led De Bary, Haeckel, Max Schultz and others (4) to follow the matter further in detail. The result was to demonstrate beyond doubt that sarcode, in vegetable and animal cells, was identical with protoplasm. Protoplasm then, that interesting substance so mysteriously endowed with vital properties, forms the basis of cell evolution. Protoplasm it is in the beginning, and protoplasm it remains to the end, since in assuming any change or changes it ceases to be protoplasm. This feature is one of the most interesting problems of cell evolution or development, for did the protoplasmic substance remain so and not experience any changes, then no development or evolution would result. On the other hand, this organic mass will necessarily cease

(2) Dujardin.

(3) Cohn: "Nachtrage z. Naturgeschichte des Protococcus pluviatilis." *Nova Acta*, vol. xxii. pp. 607-764.(4) Max Schultz: "Das Protoplasma der Rhizopoden und der Pflanzengelle." De Bary: *Myxomyceten Zeitschrift f. Wissenschaftl. Zool.*, 1859. Haeckel: *Die Radiolarien*, 1862. *Die Moneren*.

(1) Beale: "Protoplasm: Life Force and Matter," p. 24.

(1\*) *ibid.*, p. 24.



to be protoplasm in passing through the various changes necessary to consummate the purpose of its creation—the evolution of the cell and ultimately the adult form; the results consequent on such evolution or development originating from the continuity of the segmentation of the single adult cell. Now, the protoplasmic mass influenced by the gradual changes introduced by evolutionary progression, and ceasing to remain protoplasm, must, in the ordinary course of nature, be by some method renovated. That is, the elementary parts or atoms so absorbed or abstracted in this progressive feature of nature must be replaced. Consequently nature arranges for this compulsory absorption, which is continually active, by enabling all bodies to assimilate new matter to make up the material which has been utilized for what may be termed the higher purposes. The formation of centres of new living matter must not be conceived as being derived or originating from the aggregation of minute particles brought from distant parts of the organism. Because, should this be correct, only one interpretation of the phenomenon—and that an incorrect one—could be offered, viz.: that these minute particles had been existing in such distant localities, and had previously passed through, in their movements, animated parts, to enable them to arrive at the point or nucleus which became the centre of living matter. The movement of matter has been fully discussed, and the movement of renovating material is regarded as not being from distant parts to a centre, but in the opposite ratio—from the centre of living matter to the more distant surroundings. Moreover, by the investigation of these movements of living particles, it is estimated that "only matter passing towards the centre is dissolved non-living pabulum, and that if living particles were suspended in this, they would be filtered off by the formed material, and would never reach the living matter" (5). This apparently means to convey the idea, or rather fact, that in a process of the natural attraction of non-living pabulum, containing proteids or other elements imbued with life, towards the centre of assimilation, such living particles or proteids would by attraction be absorbed by the living mass through which in the natural progress to the living

centre it—the pabulum—would, by the law of attraction have to pass, that is to say, in one direction only, towards and not from the centres of living matter.

In providing for the renewal of matter abstracted in the consummation of the protoplasmic mass, we have somewhat anticipated the progressive evolution of the cell. During the progressive formation of the cell contents, a development which assumes the form of a small central point or pip is introduced by some unknown cause or causes. This is as important in the economy of cell life as is the presence of protoplasm. This feature of cell evolution had, previous to 1833, escaped the attention of observers (6). Its importance in the economy of development was soon made manifest (7), though notwithstanding the value of this body it remained neglected as the interesting vital phenomenon of protoplasm became known (8). It has now been demonstrated that this part is of quite as great importance to the elementary body as is the protoplasm. This body found within the cell is the nucleus. It was regarded as being a small vesicle; indeed, it was considered a structural formative vesicle containing a smaller nucleus; in other words, a small cell within a larger cell. In like manner (9) as it came to be recognized that protoplasm was the vital substance of the cell, so it was discovered that the form of the nucleus was of minor importance. Its vitality depends far more upon the presence in it of certain substances, the arrangement of which may vary very considerably according to the condition of the nucleus, whether it is in an active or quiescent condition, than upon its shape. Richard Hertwig (10) prefaces his remarks by the following sentence: "It is necessary to state at the commencement of my observations, as the most important point to be considered in classifying the various nuclear forms, that they all possess a certain uniformity in composition. Whether the nuclei of animals or plants, or Protista, be under examination, it is invariably seen that they are composed of a larger or smaller quantity of a material which I shall call nuclein substance—nuclein." The nucleus is not now considered as a vesicle in a cell, the idea of Schwann and Schleiden, but is defined as a "*portion of a special substance which is distinct from it, and which may vary considerably as to form, both in the resting and actively dividing condition*" (11).

(To be continued.)

VERTEBRATE FAUNA OF SHROPSHIRE.—The Caradoc and Severn Valley Field Club is appealing for assistance in compiling notes upon the vertebrate animals of the county, which it is intended to publish as soon as sufficiently complete. Lists and detailed particulars may be obtained from Mr H E Forrest, 37, Castle Street, Shrewsbury.

(5) "Protoplasm," by Beale, p. 81.

(6) Robert Brown, "Observations on the Organs and Mode of Fecundation in Orchideae and Asclepeadeae" ("Transactions of the Linnean Society," London, 1833).

(7) Matthias Schleiden, "Beitrag zur Phylogenie," Muller's Archiv, (1838). "Principles of Scientific Botany," translated by Lancaster (1849).

(8) Th. Schwann, "Mikroskopische Untersuchungen über die Uebereinstimmung in der structure und dem Wachsthum der Thiere und Pflanzen" (1839).

(9) Hertwig, "The Cell—Outlines of General Anatomy and Physiology."

(10) Rich. Hertwig, short essay which appeared in the "Beitrag zu einer einheitlichen Auffassung der verschiedenen Kernformen," Morpholog. Jahrbuch, Bd. 2, (1876).

(11) Hertwig "The Cell," p. 37.

## COLORATION AND VARIATION OF BRITISH EXTRA-MARINE MOLLUSCA.

BY ARTHUR E. BOYCOTT.

(Continued from page 292.)

AMONG the freshwater Pelecypoda, the smaller species (*Sphaerium* and *Pisidium*) have thin unornamented shells, a fact which points to the same conclusion here as in the Gastropoda, though some small marine bivalves are quite plain. But all the aquatic forms do not exhibit this monochromatic shell. There are five genera which are more or less brightly coloured. The line of argument just given is further supported by the fact that four of these are very closely allied to marine forms. *Anodonta* and *Unio* are not far from several marine Pelecypoda. *Dreissena* (1) is an only slightly modified *Mytilus* (this has been denied, see *ante* p. 291, Note 18), and is remarkable in still possessing its free-swimming larva. *Theodoxus* (*Neritina*) is very much the same thing as the marine *Nerita*, and some species live in salt water. These species then show their close alliance with marine forms by their bright coloration. At the same time it is only fair to mention two facts: firstly, *Anodonta* is a very old freshwater genus, in fact one of the earliest known, *A. jukesii* occurring in abundance in the Old Red Sandstone at Killarney, and no one seems to doubt the correctness of the generic diagnosis. Secondly, the half-way genus, *Hydrobia*, which lives in brackish water, has a unicolorous, dull, unornamented shell, while it is presumably migrating from the sea. The remaining genus, *Paludina*, offers some difficulties. Palæontological evidence shows that they are a fairly old (cretaceous) freshwater genus, and that the highly-coloured forms have been derived from much simpler ones since their immigration into fresh water (2). The immediate relationship to any recent marine forms is by no means obvious. On the other hand, ontogenetic evidence points to a more elaborate ancestor—possibly the ultimate marine one; for the embryonal hairs with which it is conspicuously decorated would indicate either a hirsute or an ornamented line of descent. The coloration, greenish and brown, may be cryptic with green weeds and brownish mud, but this hardly looks very likely. It is really rather curious that *Anodonta* should be so often brightly coloured, as it spends so much of its time deeply buried in the mud.

C. C. Fryer (3) has published some interesting

(1) Only appears in Upper Eocene geologically. It retains its bright colours even in the dark. *Brit. Conch.* 1, p. 48.

(2) A. R. Wallace: "Darwinism" (1889), p. 381. "Nature," xiv, p. 275.

(3) "Conchologist," 1, (1891), p. 25.

notes on the colouring in our freshwater mollusca. He thinks that less competition explains the horn-colour of Limnaeidae and the dull greens and purples of Paludinidae and Unionidae, which, however, he regards as "primitive." This (Darwin's) is a probable view, for it is very difficult to show that their ancestors had thick coloured shells, as I think possible. He considers that these dull greens and browns are protective, and aptly compares the colours of freshwater insects. Further, in *Neritina fluviatilis* the "chequered shell and spotted hind part of the foot may aid it in concealment among the fine pebbly sand (4) of swift streams." Speaking of *Limnaea peregra*, he says: "When the shell is thin and light-coloured, the dark-bluish animal, variegated with yellow spots and patches, is visible through the body whorl, and owing to the irregular distribution of colours obscures the outline and assimilates to the muddy bottom." These are two very ingenious observations, but they seem to be pushed quite as far as is advisable in such cases.

As far as I know, nothing further has yet been suggested relative to the normal colours of our aquatic species. None of them are transparent enough to be protected in that way, which is so common among marine forms, except perhaps a few species when very young (*Dreissena* larva). As a rule, even when quite small, they are pigmented fairly strongly in one way or another. I once took huge pains to extract a twelve-inch stone from a very muddy pond under the impression that it was the record *Anodonta cygnea* at last; but I have not heard of any similar instances.

Certain caddis-cases (*Helicopsyche*) from Colorado are said to very closely resemble *Valvata* (5), but how far this holds in England, or which way the advantage, if any, lies, I do not know.

We may next very briefly consider what is known as to the meaning of the normal coloration of the integument in the slugs (6). As mentioned above, loss of an external shell is often followed by protective colouring, according to Lang. Scharff considers that "the colours of slugs in Ireland are at all ages, as a rule, protective." With this Simroth agrees as far as the smaller species are

(4) I have seen it mostly on large smooth stones (Herefordshire) and on water-weeds (Berkshire).

(5) "Young Naturalist," 1888, p. 17: T. D. A. Cockerell.

(6) The following is largely a resumé of the excellent work of R. F. Scharff, "The Slugs of Ireland," *Sci. Trans. Roy. Dublin Soc.*, (2) iv, pp. 513-562 (1888-1892).

concerned, but he finds that the red form of *Arion ater* is refused by birds in captivity, and hence may be sematic (?). The same authority attributes a good deal of direct physiological value (in relation to external heat and cold) to the colours in, e.g., *A. ater* and *Limax maximus*, but the evidence adduced to show this seems insufficient. Scharff says that he has found a claret-coloured variety of *Arion ater* only in pine-woods where it is very harmonious. *Limax marginatus* (*arberum*) looks like a bit of bark on the trunks on which it usually sits. *Amalia carinata* (*marginata*) assimilates to the ground on which it lives. *Arion intermedius* (*minimus*) is like a little fungus just coming out of the ground. "The dark-grey lichens," on which it lives, and among which it sits openly during the day, "with the white and yellow fructification, conceal *Geomalacus maculosus* perfectly. There is no doubt that we have here a most striking instance of protective colouring," which is enhanced by the fact that this species lives conspicuously uncovered. L. E. Adams (?) attributes some influence on the colours of slugs to "protective mimicry." He adduces no instances, however, and it may be that protective resemblance is meant (?). W. M. Webb (10) has recently pointed out the resemblance between contracted specimens of *Testacella scutulum* (and sometimes *T. halotidea*) with half a broken pebble.

Having reviewed the significance of the colours which normally occur in our land and freshwater mollusca, we may consider the cases of adventitious protection which have been observed. That several shells (*Buliminus*, *Puſa*) cover their shells with bits of dirt, and so conceal themselves, is a very old observation (11). It appears to me, however, that it probably only applies in some instances. *Buliminus obscurus* and *Puſa secale* (young) are at least as often found clean as muddy, and even when a considerable quantity of dirt is adhering to their shells are really as easy to see as when they are without it. Where *Buliminus obscurus* lives on smooth-trunked trees, such as the beech, however, it is very probably of service (12), but, as a rule, I think it shuns such open situations, and hides away under stones and other debris, where any protective covering would be of but little use. I have noticed that round the edges of ploughed fields and in other muddy situations *Fruticicola hispida* is often covered with mud, and so rendered more difficult of detection. A similar habit has been attributed to *Vitrina*

*peilucida* (13), and *Succinea*—especially, perhaps, *S. oblonga* (14)—is often covered with dirt.

Among the aquatic species adventitious coatings, probably of some protective value, are common (15). Old specimens of *Planorbis*, *Limnaea*, *Paludina*, etc., are often covered with a thick algaoid and confervoid growth. Measured on the dry, empty shell, more than a year after after collection, when a good deal had probably been removed by accident, I have found that it may amount by weight to 11 per cent. of the dry shell in *Limnaea stagnalis*, and from 5.2 to 18 per cent. in *L. peregrea*, the two first specimens being very ordinary ones. To my own eyes, at any rate, specimens coated with mud are more difficult to see than these, and are often exceedingly hard to distinguish from accidental nodules of mud or pebbles on the bed of the stream or pond. The nature of the coating varies: it may consist of precipitated  $\text{CaCO}_3$ , which also generally coats some (16) of the plants; or, it may be simply ordinary dark mud, which, either from the water getting muddy from the bottom being stirred up, or by a sudden sinking of the level of the water, covers up the shells. In the latter case the shells which are left high and dry, so long as they do not move, are by this means in all probability considerably helped in escaping the notice of rapacious birds and other enemies. Indeed, I have found *Pisidium* in this position almost impossible to collect without entering the water, and thus bringing one's eyes quite close to the mud. The notorious *Limnaea truncatula* habitually sits on the muddy bank just out of water, and is nearly always protectively covered with mud. By the nature of the case, the colour of the coating varies, and as a rule harmonizes, with the surroundings. Thus, in a ferruginous pond, where the mud is red, the shells have a red covering too, and where  $\text{CaCO}_3$  is precipitated on shells, it is also precipitated on some of the surrounding objects. The colouring of the shell in *Planorbis* and *Limnaea* depends very much on its surroundings during growth. The red colour of *Planorbis* in ferruginous water is not merely superficial, the prismatic layer is tinged red too (E. W. W. Bowell), and the varying tint of *Limnaea* seems often to depend partly on inclusions during growth (17). Some species of both Gastropoda and Pelecypoda (*Valvata*, *Sphaerium*, *Pisidium*) nearly always sit on the muddy floor with a slight covering

(13) W. E. Collinge in "Zoologist" (3), xlv, p. 46b.

(14) The *Succinea oblonga* of Britain is very likely generally *S. arenaia*, Bouch., if the two are distinct, real *oblonga* also occurs.

(15) C. C. Fryer, "Conchologist," i. (1891), p. 25.

(16) There is apparently a selective capacity among various water plants for getting this precipitate on their surface.

(17) I once sent a drawing of part of the operculum of *Valvata cristata* to a fellow conchologist, who wrote to me that I had sent a "study of diatoms" by mistake. This species seems to be the most favourable for observing the various extraneous inclusions in the operculum.

(7) Cf. W. E. Collinge "Conchologist," i. (1891), p. 13.

(8) *Op. cit.*, p. 22.

(9) E. B. Poulton's "Colours of Animals," 1890 nomenclature is the standard one to which I refer.

(10) Journ. of Malacology, vi. (1895), p. 52.

(11) "Omnes enim, quas inveni, terra obductae erant."

O. P. Müller Veridum terrest. et flux. historia, ii. (1774), p. 105. *Buliminus obscurus* lives "in truncis fagi."

(12) See especially J. G. Jeffrey's B. C., i. pp. 2, 5, 239.

of mud on them. The coating in *Valvata piscinalis*, however, may be very thick and firmly adherent. They are thus practically impossible to distinguish with any certainty by the eye.

Whether the shell is incrustated or not is largely a matter of locality. In Oxfordshire *Buliminus tentaculata* "almost invariably covers its shell with an earthy incrustation" (18), while in Herefordshire it is almost as invariably clean. *Paludina vivipara* is "incrustated with an earthy coating, upon which zoophytes and algæ often grow. I have seen it entirely covered with a profuse growth of *Batrachospermum moniliforme*" (18). It has been recorded that this species lose most of the "thick incrustation" on their shells after a few weeks in clean water in an aquarium (19), an observation which I can, to a certain extent, confirm.

In July, 1896, I collected some *Paludina*, *Pianorbis cornuus*, etc., in a small branch of the Thames in Berkshire, from among a thick growth of weeds, and they were in many cases only slightly incrustated with mud and weed growth. The same stream was then very thoroughly cleaned out, and the specimens from just the same places in June, 1897, were conspicuously more covered up and concealed with adventitious matter in their now almost weedless and open habitat.

Finally, before going on to the variation of our mollusca, we may briefly consider what is known generally as to the nature of these colours. Contrary to a statement which is sometimes made (20), the colouring matter, as a rule, in British Gastropoda resides in the main in the superficial part of the calcareous part of the shell. This may be easily demonstrated by peeling off the periostracum (with the help of a brief application of fairly strong acid), when the pigmentation will still be seen on the freshly exposed surface. But it is considerably modified by the periostracum: e.g., the difference in colour between *Tachea nemoralis* v. *castanea* and *T. hortensis* v. *lilacina* has been ascribed solely to differences in the nature and tint of the periostracum, which is thicker and browner in the former species; and there is no doubt that deperiostracization does bring the tints of the two shells much nearer to one another, *castanea* becoming much more violet in tint. Again, the violet-purple tint sometimes seen on deperiostracized portions of dead and empty shells of *Cryptomphalus*, as contrasting with the brownish colour of the parts which are still covered with the periostracum, is familiar to most collectors. Going still further, we find that in some species the colouring matter resides entirely in the periostracum (e.g., *Clausilia laminata*, *Acanthinula aculeata*).

This seems mainly the case with most horn-coloured species; but some of these, at any rate, have a slight brownish tinge in the calcareous matter (some *Hyalina*, *Amphibulima* = *Succinea*). With regard to the aquatic species, Mr. Bowell says: "Really the species which come under this designation (horn-coloured) should be classed as colourless. *Bythinia tentaculata*, for instance, varies from brownish horn-colour to clear white, the difference being solely due to the presence or absence of a sufficient amount of adventitious matter. From Burnham, in Somerset, I have some white forms. They do not really represent albinism."

While admitting that the tint of the shell may be thus somewhat modified (that is after a good external cleaning), I think this is an extreme view. The separated (21) periostracum of *B. tentaculata* is brown, and less brown than the intact shell. Further, albino and brown specimens are found together, and the bleaching action of light acts rather readily on this species, as seen in the museums, which is hardly what we should expect if the colouring were entirely "adventitious" in nature. In the Pelecypoda it is the periostracum which contains the pigmentation.

Whence comes this pigment in the shell? Everyone is familiar with the black or dark-brown patches or bands on the mantle of *Tachea* corresponding in position with the bands on the shell, and with the densely but patchily pigmented mantle of *Cryptomphalus*, with its dark and light patched shell. The suggestion contained in this is probably correct: viz., that the colouring of the shell has something to do with the pigment in the mantle. On the other hand, *Limnaea* is often quite thickly pigmented, but still has a plain shell. Examined microscopically, the pigmentation of the mantle in *Tachea* is seen to be due to an accumulation of pigment cells of a squarish or oblong (but irregular) outline, filled thickly with globules, which, seen singly, appear rather pale-brown when examined fresh. In *Limnaea* the pigment cells are of the more usual stellate, branched type, and contain apparently granules rather than globules, the pigment being more amorphous. This pigment has been studied in *Limnaea* by E. André (22). He finds that it is not melanin, as it is usually called, but an iron-containing substance with similar properties to the melaine of the ink-bag of Cephalopoda. It differs from the group of vertebrate pigments known as "melanin" in some of its reactions and solubilities.

It is noticeable that in newly-hatched *Paludina* the mantle becomes pigmented, while the shell

(18) J. F. Whiteaves, *op. cit.* p. 15.  
 (19) R. M. Christy: "Zoologist" (3) v. (1881), p. 181.  
 (20) e.g., A. M. Marshall and C. H. Hurst: "Practical Zoology," ed. 2 (1888), p. 107.  
 W. Williams: "Shell-Collectors' Handbook" (1888), p.

(21) Periostracal "casts" of this species are not hard to prepare with dilute acid.

(22) *Revue Suisse Zool.*, iii. (1895), p. 429. *Journ. Roy. Micr. Soc.*, 1896, p. 303. "Melanin" seems at best to be only a generic term.

still remains for some little time quite without any trace of bands, just as in young *Limnaea*, only that in the latter case the shell remains without pigment permanently.

In "*Helix*" a granular pigment occurs in the epithelial and connective tissues, especially in spring, and is related to the pigment of the shell<sup>(23)</sup>. Mr. Bowell, some time ago, noticed pigment-granules of various sizes in the fat-cells near the heart in *Limnaea*, and in the leucocytes of *Tachea*, and I can confirm the observation for the blood of *Cryptomphalus*. It is interesting in this connection to note the relation which has been established between the varied pigments found in the amoeboid corpuscles and tissues generally of some Echinodermata and the pigmentation of the shell in the same group<sup>(24)</sup>.

The nature of these pigments when they get into the shell (for there seems no improbability in assuming a close connection between the body and shell-pigments)<sup>(25)</sup> is obscure. Krukenberg has described the brown, red and yellow pigments as "lipochromes"; and has found what he calls "biliverdin" in the shells of *Haliotis*, *Turbo* and *Trochus*. I, however, very much doubt the pigments of, say, *Tachea* or *Anodonta* being lipochromes as usually defined<sup>(26)</sup>; they are not, so far as my experience goes, soluble in alcohol, in which the shells may be kept for a long time without apparent alteration. Mr. Bowell tells me that the brown in *Succinea* is exceptional in being partially soluble in alcohol. It also seems very undesirable that the name "biliverdin" should be applied to a pigment when its identity with the well-known vertebrate pigment, to which the name belongs, has been by no means satisfactorily established. C. A. Mac Munn<sup>(27)</sup> finds haematoporphyrin in the integument of brownish specimens of *Limax flavus* and *Arion ater*, from which it may be extracted with a mixture of rectified spirit and sulphuric acid. *A. ater* yields also to the same reagent a black or greyish-black pigment, which occurs microscopically in granules. In these mollusca enterohaematin (Sorby) is found in the bile, so called, and histohaematin in various tissues and organs<sup>(28)</sup>, and the haematoporphyrin is a metabolite of these. He considers that the "haematoporphyrin of the slug's integument is

an excretion<sup>(29)</sup>, and possibly it may be of use at the same time either as a sexual adornment or for protective purposes."

Haemoglobin is rare in mollusca. It occurs, however, in the general blood system of *Planorbis* (in the plasma, not in corpuscles), and in the pharyngeal and buccal muscles of *Limnaea*, *Paludina*, etc.<sup>(30)</sup>. It is very possible that certain products of these pigments are used for shell-colouring. It is a very noticeable fact that the whole genus *Planorbis*, and especially *P. corneus*, are very frequently tinged more or less deeply with red. As was mentioned above, this colour is not a mere superficial incrustation, and whether the water is "ferruginous" or not, *P. corneus* generally manages to become somewhat erythric. It appears, in fact, as if this genus had a special selective capacity for any iron<sup>(31)</sup> in the water, which is especially developed in *P. corneus*. But it is not unreasonable to suppose that the haemoglobin contributes some of the colour; this supposition is, I think, borne out by the fact that the haemoglobin is more strongly developed in *P. corneus* than in the other members of the genus, as is evidenced by the fact that its egg-capsules are very often coloured red by it<sup>(32)</sup>, whereas they are colourless in the rest of the genus.

(To be continued.)

BRITISH MOSSES.—Mr. E. Charles Horrell is creating an interest in the distribution of British mosses by inviting bryologists to assist him in preparing a Moss Catalogue of the species in these islands, after the manner worked out for the flowering plants by Watson in his "Cybele." This has already been done to some extent in the second edition of the "London Catalogue of British Mosses" for the eighteen Watsonian provinces; but Mr. Horrell has made careful search through the literature of the subject in magazines and elsewhere, and finds there are still about sixty Watsonian vice-counties in Great Britain with no lists of the commoner species. Anyone who can help in this investigation of the distribution of our moss-flora should communicate with Mr. Horrell, 44, Brompton Square, London, and he will furnish particulars of the plan and what is wanted in the way of lists.

<sup>(23)</sup> M. von Linden, Journ. Roy. Micr. Soc., 1896, p. 303.

<sup>(24)</sup> See A. Gaingee: "Physiological Chemistry," I. (1886), p. 124.

<sup>(25)</sup> A. Dastre and N. Floresco ("Arch. de Physiol. Norm. et Path.," Jan., 1875, p. 182) mention incidentally in a paper on another subject that they have shown the identity between the body and shell pigments; but I can obtain no more detailed information on the point.

<sup>(26)</sup> See e.g. H. I. Newbigin, Journ. of Physiol., xxi. (1897), p. 127.

<sup>(27)</sup> Journ. of Physiology, vii. (1896), p. 245.

<sup>(28)</sup> See Mac Munn in Proc. Physiol. Soc. In Journ. of Physiol., v. (1875), p. xxiv; Proc. Roy. Soc., xxxix. (1876), p. 245.

<sup>(29)</sup> e.g., the pigments of some lepidoptera (Pteridae) have been shown to be uric acid derivatives; see "The Pigments of the Pteridae: a contribution to the Study of Excretory Substances which function as ornament," F. G. Hopkins, Phil. Trans. R. S., vol. 186 B. (1896), p. 661.

<sup>(30)</sup> E. K. Lankester: Proc. Roy. Soc., xxi. (1872), p. 71. H. C. Sorby's doubts as to the identity of the red colouring matter of *Planorbis* and haemoglobin are not shared by Preyer and A. Gaingee (op. cit. p. 130). I have got the NaCl haematin reaction—from *P. corneus*.

<sup>(31)</sup> Perhaps we too often assume that any red is due to iron; it may be something totally different. J. F. Whiteaves (op. cit. p. 13) implies a similar selection of a ferruginous coating by *Planorbis* "*pudellum*."

<sup>(32)</sup> Spectroscopically, by Mr. E. W. Bowell.

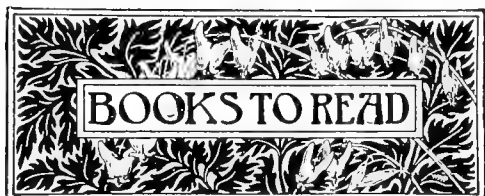

NOTICES BY JOHN T. CARRINGTON.

*Natural History (Vertebrates) of the British Islands.* By F. G. AFLALO, F.R.G.S., F.Z.S. 498 pp. 8vo, with 4 plates, 70 illustrations in the text, and a map. (Edinburgh and London: William Blackwood and Sons, 1898.) 6s. net.

The full title of this work is "A Sketch of the Natural History (Vertebrates) of the British Islands, with a Concise Bibliography of Popular

to be one of the most complete compilations of its kind we have met with. In preparing the list the author reiterates a common complaint that when secretaries of natural history societies are addressed with regard to the business of their respective societies, many of them appear too much occupied for outside correspondence. This is much to be regretted for the benefit of the societies, as some well-known clubs appear in this list without any particulars as to their addresses or times of meeting. As a whole we can recommend this work, especially to the numerous public libraries, schools and other places where such a book of reference would be sure to receive appreciation. The illustrations are effective, many being by Mr. G. E. Lodge, which show a certain originality of treatment, as will be observed in the specimen here reproduced by the kind permission of the publishers.



RED GROUSE.

From F. G. Aflalo's "Sketch of the Natural History (Vertebrates) of the British Islands."

Works relating to the British Fauna, and a List of the Natural History Societies in the United Kingdom." The book is preceded by an introduction occupying nineteen pages, and then follows a short account of the 700 or so vertebrate animals in detail, which is concisely written and quite sufficient for the class of readers for whom this work is intended. These particulars are accompanied in each group by a scientifically arranged list of the species, with the popular names. The appendices will be found most useful, the first containing a list of books upon the British vertebrate fauna. They are arranged under "General," "Mammals," "Birds," "Reptiles" and "Fishes." This bibliography occupies eighteen pages of closely printed titles. The second appendix is a list of the natural history societies and field clubs of the United Kingdom, which appears

*The Story of Life in the Seas.* By S. J. HICKSON, D.Sc., F.R.S. 182 pp. small 8vo, with 48 illustrations. (London: George Newnes, Ltd., 1898.) 1s.

This is one of the Newnes Library of Useful Stories, and considering the short space at his disposal, the author gives a good general idea of the animal life found in the seas and oceans of the earth. Of course, it is really a vast subject, and one requiring many large volumes. Dr. Hickson, however, touches only on its popular aspect, but he makes it sufficiently scientific to justify its appearance. This little work will doubtless cause many of its readers to take more than a superficial interest in some of the branches of marine zoology, when they will go elsewhere for more detailed instruction. This is a pleasant addition to the series of useful little books in this "Library."

*Audubon and His Journals.* By MARIA R. AUDUBON. 1,100 pp. large 8vo and 37 illustrations, in two volumes. (London: John C. Nimmo, 1898.) £1 10s. net.

This handsomely produced book was recently published in America, and the English edition before us is practically identical. The two volumes make an interesting addition to any naturalist's library, especially for those who are fond of ornithology. Miss Audubon has included some zoological and other notes by Dr. Elliott Coues which add to the value of the journals in clearing up occasional doubts that might have arisen in the minds of readers with reference to the identity of birds mentioned by Audubon.

The name of Audubon is familiar to every naturalist and field worker in the world; but on the American continent it is loved and revered much as is the name of Gilbert White in this country. It is rather the fashion in these times to speak depreciatingly of field naturalists such as Audubon, and to remind people that their work was unscientific. Those who take this line of thought are apt to forget that true scientific work grew from the early observations of men like Audubon. No one regretted more than himself his absence of early scientific training. This regret is repeatedly expressed in his journals, especially towards the end of his active life. For instance, writing during his visit to Cambridge in

March, 1827, he exclaims, as though addressing his wife "Oh, my Lucy, that I also had received a University education." What one admires more than aught else, in reading Audubon's written thoughts, is the earnestness and self-sacrifice displayed from quite an early period. We should remember that he came from a class and lived in a country where, and at a time when, the study of Natural History was looked upon with more or less disdain. In those days there was available no systematic scientific training as now understood. Indeed, the social conditions in America were such as to discourage natural science studies. The people were divided into two great sections: the first objecting to science as a loss of time, when the students were expected to be devoting their energies to accumulating dollars by trade, fair or otherwise; the second class equally objecting

on the score of it being impertinent to inquire into the works of Providence. The volumes before us show much affectionate thoughtfulness on the part of the great ornithologist's grand-daughter in editing his journals, and she has collected with care everything which has tended to produce an admirable monument to Audubon. The volumes include much which has not previously appeared in public, including three of his hitherto unpublished drawings of birds. Audubon commenced his journals early in life, and in one place mentions twenty-seven volumes. Unfortunately numbers of these have utterly disappeared, and no trace of them can now be discovered. Luckily, however, the years represented in these recently published volumes are among the most important of his

life. Including other years, they cover the period of his visit to Europe while seeking subscribers for his great work on the birds of America. They give his impressions of people he met in Great Britain, where he seems to have been received with much kindness and some honour. The book was published by subscription, and the reader of these journals will not fail to follow with pleasure Audubon's anxieties, hopes and successes, which in the recounting show him to have been very human. The whole work was completed in 1838, and appears to have been originally issued from Edinburgh and London in eighty-seven



JOHN JAMES LAFOREST AUDUBON. From "Audubon and His Journals."

parts of five folio plates each, making a total of four hundred and thirty-five plates, giving one thousand and sixty-five figures of birds. On completion the plates were bound in four volumes without text description, the original price being two guineas each part. A complete copy of the original in good condition is now worth upwards of £400, and is almost impossible to obtain, even at that high price. The work was afterwards issued with text and plates together, under the title of "Ornithological Biography," in five large octavo volumes, published in Edinburgh in 1831 to 1839. Another edition appeared in 1840 to 1844 with text and plates, under the original title of "Birds of America." Since then other editions have been published. At the commencement of the first volume of "Audubon and His Journals" is a sketch written by himself of his active life. This sketch is continued up to



the period of his death by his grand-daughter. It is deeply interesting reading for the lover of nature, and Miss Audubon has done well to point out the simple, generous character of her grandfather. Unfortunately some biographers have described him as vain and ungenerous, but we think the reader will agree with the editor of his journals in her opinion that such a character is quite unfounded. The illustrations in these volumes include ten portraits of Audubon, which show him as a man of refined features with keenly observant eyes, doubtless inherited from his father, a French admiral, though in some of the pictures we may trace the ancestry of his Spanish Creole mother.

These volumes are well worthy a place in every public library, when they would be doubtless largely read in this country by many who are not naturalists, as well as by the great and increasing number who take more than a passing interest in the works of Nature.

*The Naturalist's Directory for 1898.* 128 pp. 8vo. (London: Upcott Gill. 1898.) 1s.

Although thicker by many pages than its predecessor of last year, this "Directory" is still very incomplete. It is nevertheless worth its published price, and may save some of our readers trouble in looking up addresses. It is to be hoped the editor will be able, before the issue of the next annual edition, to give much more attention than hitherto in obtaining the immense number of names and addresses which have still to be included in anything nearly approaching a perfect directory, such as ought to be issued, if even at a higher price.

*Report of Field Columbian Museum, 1896-97.* 91 pp. large 8vo, 14 plates. (Chicago: 1897.)

The frontispiece of this number is a picture of the Field Columbian Museum of Chicago, which is an immense building apparently admirably designed. The other plates are interesting, and perfect models of what illustration should be. In fact, we have rarely seen any reproductions to equal them for clearness in detail as specimens of interior photography. The report is necessarily a recapitulation of the work done during the previous year, consisting of additions to the museum and library, scientific lectures, and cataloguing the objects in the museum, to which collection many valuable additions have been made. The Institution is evidently making rapid progress.

*Fishes and Reptiles of Somaliland.* 22 pp. large 8vo, one plate. (Chicago: 1897.)

This is one of the publications of the Field Columbian Museum zoological series, and consists of a list of the fishes and reptiles obtained in the Museum East African Expedition to Somaliland, in 1896. It is edited by Mr. S. E. Meek. The plate is an excellent drawing of a new species of fish of the family Scorpaenidae, named *Pterois ellioti* Meek. We regret to see, however, that it is described from a single specimen from Berbera, but the plate indicates a very distinct-looking form. In addition to this new fish, there are three new Amphibia and a couple of new Lacertilia, also described by Mr. Meek.

*A New Astronomy.* By DAVID P. TODD, M.A., Ph.D. 480 pp. 12mo, with six coloured plates and a large number of illustrations in the letterpress. (New York, Cincinnati and Chicago: American Book Company, 1898.) \$1.30.

Without exception this appears to be one of the most complete handbooks on astronomy, and

exceedingly suitable for schools and students. The author is fully qualified to write such a work, as he is not only Director of the Amherst College Observatory, but also well known as leader of two solar eclipse expeditions under the auspices of the United States Government. One being to the West Coast of Africa, and the other to Japan. Dr. Todd visited the latter country on a second occasion in charge of an astronomical expedition promoted by Amherst College. He has certainly succeeded in producing a most attractive and popularly written handbook. This has been attained by placing more importance on the physical than on the mathematical side of astronomy. Thus he creates a rapid interest in the minds of his readers, which would be more difficult to attain by the digestion of ponderous volumes. The selection of subjects for illustration indicates that most careful attention has been given to that important department. The coloured plates are a marked feature of the book, and some of them are from observations of the author. The frontispiece is one of the most striking, it represents the colour effects on the landscape as seen by his party in Japan during the total eclipse of 1896. There is hardly a subject connected, directly or indirectly, with astronomy which is not mentioned and explained, including the names and use of instruments, terms and methods of calculating distances. We strongly recommend this handbook for the use of schools and public libraries.

*Queensland Aborigines.* By WALTER E. ROTH, B.A., M.R.C.S., L.R.C.P. 209 pp. royal 8vo, with 438 illustrations on twenty-four plates. (Brisbane: Edmund Gregory. London: Queensland Agent-General's Office, 1897.)

The full title of this work is "Ethnological Studies among the North-West Central Queensland Aborigines." It is a valuable contribution to ethnology, the author having had exceptional opportunities, while medical officer, of studying the language, customs and habits of the people whom he portrays. Dr. Roth has made good use of those opportunities, and the reader cannot fail to remark upon the systematic manner in which he has arranged his information. It consists of studies in the native language, elementary grammar, vocabulary, and an exceedingly interesting chapter upon the expression of ideas by manual signs, which are much practised, and are as elaborate as the code of signs adopted by civilized races in communicating with deaf mutes. These are illustrated by 213 figures, each expressive of an idea. This book contains a remarkable chapter on ethnopornography, a subject which is too rarely dealt with in a scientific manner.

*On Laboratory Arts.* By RICHARD THRELFALL, M.A. 350 pp. 8vo, illustrated by 91 figures. (London and New York: Macmillan and Co., Limited, 1898.) 6s.

The author of this work is Professor of Physics in the University of Sydney, and its object is the laudable one of teaching young physicists to render themselves as independent as possible of the scientific instrument maker. The author points out that there are many students with excellent powers for observation and capacity for carrying out experiments providing the instruments are ready to hand, but who would be incapable of making their own apparatus in case of failure, or breakage. He has, therefore, prepared a number of hints and instructions which will be found extremely useful in the amateur's laboratory. Independently



of the convenience of being able to make one's own instruments, even of only the more simple in character, the mechanical training obtained during their construction is of much value to a physical student. The book is divided into four chapters, with a couple of appendices. Chapter i. treats of the Manipulation of Glass, and Glass-Blowing for Laboratory. Professor Threlfall goes elaborately into the subject of glass and glass-blowing, and gives figures of the blowpipes both hand and mechanical, where the current of air is obtained by a foot bellows. There are instructions for welding tubes, making thermometers, and, in fact, doing much that is likely to be needed. The appendix to this chapter is on the preparation of vacuum tubes for the production of Röntgen radiation, and for the completion of the tubes by the attachment of cathode and anode. Chapter ii. is on Glass-Grinding and Optician's Work. Simple instructions are given to enable the student to make his own lenses, and afterwards to grind and polish them, with mathematical accuracy. Next is information for coating glass with aluminium and working in that metal, gilding glass, with formula for solutions, the use of the diamond-cutting wheel, cutting rock sections and sections of soft substances, the production of quartz threads, modes of soldering quartz and metals, brazing, the construction of electrical apparatus, the treatment of ebonite or hard rubber, and instructions for electro-plating, with many more equally interesting arts.

*Lessons with Plants.* By L. H. BAILEY. 522 pp. 8vo, illustrated by 446 drawings. (New York and London: Macmillan and Co., 1898.)

The author, who is connected with the Horticultural Department of the Cornell University, describes his work as "Suggestions for seeing and interpreting some of the common forms of vegetation." The delineations are from nature, by Prof. W. S. Holdsworth, of the Agricultural College, Michigan. These drawings are well selected and effectively rendered. Although the book has been prepared for American readers, English students will find that nearly all the plants selected are familiar in this country, either in themselves or through allied species. The author's intention has been to prepare for a teacher of children a book which will enable him, even if not a botanist, to explain the different forms of plant growth with simplicity, and at the same time accurately. Every subject has its pictorial illustration, and it is recommended that the teacher should himself gather a specimen to match the illustration, and then, with the real plant, explain it to his class or pupil as does the author in the pages before us. His object all through is to make the subject as simple and attractive as possible, so that the first steps to a systematic study of botany may be such as to tempt the pupil to continue the work for the love of it. The whole of the examples in this handbook are of external structure. With its excellent illustrations and clear letterpress, it cannot fail to become a favourite with both teachers and scholars, but much of its success will depend on the aptitude of the teacher to eliminate all the "dryness" of the subject, though here we find it nearly absent. The worst of the modern system of teaching is, that more attention is paid to the passing of pupils in examinations or the earning of capitation grants, than to creating a taste for some subject of study which will become a relaxation in after-life.



SIR HENRY BESSEMER, F.R.S.—It falls to the lot of but few of the whole of those who are devoted to science to revolutionize a great industry by its application. It generally happens also that every opposition is met with by the inventor before he gets his applied science recognized. Such was the case with Sir Henry Bessemer and his improvements in the manufacture of steel with which his name will be always associated. Born on January 19th, 1813, at Charlton, in Hertfordshire, his death took place on March 15th last, in his 86th year. Sir Henry's father was a man of artistic culture and a member of the French Academy of Sciences. From an early age Henry Bessemer devoted himself to scientific research, with the object of applying it to invention of commercial objects. One of his first successes was a gold paint, made from Dutch metal. Thence his mind seems to have ranged over a wide field, for we find he spent some £10,000 in Patent Office fees alone during his long lifetime. These applications include such wide apart objects as steamboats, astronomical telescopes and sugar-making machinery. His chief success was due to his passion for investigations in metallurgical science. Bessemer, during the Crimean War, erected works at St. Pancras, London, with the intention of making guns, and devoted considerable energy and money, but without much result. After a couple of years or so he hit upon the method of converting cast iron into steel, and as is so frequently the case in great discoveries—by an accident. Up to that period steel had been produced by the operation of "puddling," which was both laborious and expensive, as only masses of about seventy-five pounds could be treated in one furnace. It was the custom to stir the molten iron with long rods, so as to expose as much surface as possible to the atmospheric air, with the object of decarbonizing the metal. Bessemer, it is said, in the first instance had his attention drawn to the sufferings of the partly naked men who were the puddlers, and conceived the idea of driving hot air into the mass by mechanical means, until it was as efficiently decarbonized as by puddling. On the suggestion of George Rennie, in 1856, he read a paper on his invention before the British Association Meeting, at Cheltenham, and though it commanded some notice, it was not considered sufficiently important to publish. Then came a period of hostile opinion and failure of those who had taken licenses to work the process. Bessemer, however, plodded on, fully believing in its ultimate success. After another two years' struggling, he made steel as good as by puddling, but no commercial man would have any connection with what had been understood to be a failure. He persuaded Robert Longsdon and the Galloways, of Manchester, to help him to start works at Sheffield, with the result that now the Bessemer process is considered one of the finest industries in the world, and Sir Henry received almost every decoration of honour available for the man of science.—J. T. C.



M. ALBERT GAUDRY has been appointed joint Director of the Natural History Museum in Paris. The museum has lately received some interesting specimens from the region of the Niger, presented by Lieutenant Hourst.

We have received from Dulau and Co., 37, Soho Square, London, their catalogue of zoological works in the classes Crustacea, Arachnida, Parasita and Myriapoda. Readers interested in these subjects will find this catalogue useful.

LONGMANS AND Co. are publishing a volume by Dr. Henry J. Curtis, on the "Essentials of Practical Bacteriology," with illustrations. It will be useful to many who take an interest in bacteria and the work accomplished by these important living atoms in nature.

Two eminent fathers of philosophy are to have their portraits taken in oils—Lord Kelvin for the portrait gallery of the Royal Society, and Herbert Spencer for the National Portrait Gallery. The latter is by Professor Herkomer, whose beautiful etchings of Darwin and Tennyson are so well known.

PROFESSOR RAPHEAL BLANCHARD, Professor of the Faculty of Medicine of Paris, is engaged on editing and publishing a new serial, under the title of "Archives de Parasitologie," which is to be devoted to the study of living agents which provoke maladies in men and other animals. It will contain original and general articles upon these subjects. This important publication may be obtained from the Administrator, 15, Rue de l'Ecole de Médecine de Paris, the annual subscription being thirty-two francs.

SOUTH London is about to have another public museum. Mr. Frederick J. Horniman, M.P., has purchased a site of about fifteen acres of land between Lordship Lane and Forest Hill railway stations. On this, he will erect a suitable building, where, when finished, will be transferred Mr. Horniman's collections that have already been exhibited from time to time to the public at Forest Hill. On the ground is a large villa, which is to be fitted as a free library and club house, where the donor proposes to invite local scientific clubs to hold their meetings free of rental. The unoccupied ground is to serve as a park.

A REMARKABLE meteor is reported by Mr. Steer, second officer of the P. and O. steamer "Peninsular," on February 8th. The time is given as 2.52 a.m., mean time, and the place of observation as east longitude  $48^{\circ} 18'$ , and north latitude  $13^{\circ} 22'$ . The object is described as a dull red ball, about one-eighth the size of the sun, falling slowly, but without a trail. When at an altitude of about  $3^{\circ}$  it burst with extraordinary brilliancy, throwing out what seemed to be flames in all directions, lighting up the whole southern horizon. The object was said to be bearing south half west. Mr. Steer says it did not appear like a falling star, and he has never previously seen anything like it.

ATTENTION has latterly been drawn to the association of science and the Society of Friends. It is remarkable that the members of that society have produced more eminent men of science than any other body of equal numbers.

THE United States Geological Survey has issued, free of charge, a map of Alaska, accompanied by forty-four pages of descriptive text, explaining the geography, geology and gold deposits of the territory.

PROFESSOR W. A. ROGERS, Assistant Professor of Astronomy at Harvard University from 1875 to 1886, died on March 1st, at the age of sixty-one years. He was a Past-President of the American Association for the Advancement of Science.

THE Government has included in its Bill for appropriation of money for public buildings, the large sum of £800,000 for the completion of the South Kensington Science and Art Museums. This work has been already too long delayed, so it is satisfactory to think it will be soon commenced.

A WEEPING-WILLOW (*Salix babylonica*) is now being specially grown by some of the Indian forest officers, on account of the demand for its wood for cricket bats. Hitherto the supply of this wood has been limited, and latterly eagerly sought for making bats.

VISITORS to Paris from June 13th to July 3rd will have an opportunity of seeing how far behind is England with regard to motor-cars. During that period the French Automobile Club will hold an exhibition of all relating to mechanical traction for road vehicles.

A UNIVERSAL and International Exhibition will be opened at Dijon on June 1st, 1898. The exhibition will remain open until October 31st. There will be fourteen sections, including Fine Arts, Hygiene, Salvage, Science, Social Economy, Heating and Ventilation, Electric Traction, Education and Work of Women, Commerce, etc.

MR. P. M. C. KERMOND, Hon. Sec. of the Isle of Man Natural History Society, gives, in the "Geological Magazine" for March, an entertaining account of the discovery of nearly perfect remains of an Irish elk in the Isle of Man. It is a large adult specimen, standing about six feet tall at the shoulder.

THE specific weight of hens' eggs has been used to prove their fresh condition. This may be accomplished by making a solution of 4.23 ozs. (= 120 grammes) of common salt to 1.76 imperial pint of water (= one litre). If the eggs sink in this they are quite fresh, but if they float therein they are stale according to the degree of flotation. Some recent experiments in the preservation of eggs have shown, after being kept eight months, the following percentage results. Eggs kept in salt water, all uneatable; in a wrapper of paper, 80 bad; in glycerine solution of salicylic acid, 80 bad; rubbed with salt, 70 bad; covered with paraffin, 70 bad; varnished with glycerine and salicylic acid, 70 bad; plunged in boiling water for twelve to fifteen seconds, 50 bad; in a solution of alum, 50 bad; solution of salicylic acid, 50 bad; varnished with waterglass, 40 bad; varnished with collodion, 40 bad; covered with lac, 40 bad; preserved in wood ashes, 20 bad; in mixture of boric acid and waterglass, 20 bad; potassium manganate, 20 bad; varnished with vaseline, all good; in limewater, all good; in a solution of waterglass, all good.



CONDUCTED BY FRANK C. DENNETT.

		Rises.		Sets.		Position at Noon.	
		h. m.	h. m.	h. m.	h. m.	R.A.	Dec.
Sun	April 2	5:55 a.m.	6:33 p.m.	0:47	...	5° 3' N.	
	12	5:13	6:49	1:24	...	8° 48'	
	22	4:51	7:7	2:1	...	12° 18'	
		Rises.		Sets.		Age at Noon.	
		h. m.	h. m.	h. m.	d. h. m.		
Moon	April 2	1:24 p.m.	5:51 p.m.	3:37 a.m.	11	3 23	
	12	2:07 a.m.	4:56 a.m.	8:40	21	3 23	
	22	4:50	1:6 p.m.	9:30 p.m.	1	13 39	
		Souths.		Semi		Position at Noon.	
		h. m.	Diameter.	R.A.	Dec.		
Mercury	April 2	1:2 p.m.	5' 0	1:45	...	12° 26' N.	
	12	1:11	4' 0	2:34	...	18° 7'	
	22	0:45	5' 2	2:48	...	18° 51'	
Venus	2	0:47	5' 0	1:30	...	8° 33' N.	
	12	0:51	5' 1	2:17	...	13° 12'	
	22	1:3	5' 2	3:5	...	17° 19'	
Mars	12	9:53 a.m.	2° 2	23:15	...	6° 5' S.	
Jupiter	2	11:33 p.m.	20° 4	12:19	...	0° 18' S.	
	12	10:19	20° 3	12:14	...	0° 11'	
	22	10:6	20° 0	12:10	...	0° 35'	
Saturn	12	3:21 a.m.	8° 2	16:43	...	20° 21' S.	
Uranus	12	2:43	1° 9	16:4	...	20° 36' S.	
Neptune	12	3:58 p.m.	1° 3	5:18	...	21° 47' N.	

MOON'S PHASES.

Full	New	1st Qr.	3rd Qr.
Apr. 6	Apr. 20	Apr. 13	Apr. 27
9:20 p.m.	10:21	10:21	2:28 p.m.
3rd Qr.	1st Qr.	...	2:5 a.m.

In perigee April 9th, at 10 p.m., distant 227,300 miles; and in apogee on 25th, at 7 p.m., distant 251,800 miles.

CONJUNCTIONS OF PLANETS WITH THE MOON:

pr.	Star	Time	Planet	Position
6	Jupiter	4 a.m.	planet	6° 59' N.
10	Saturn	5 p.m.	"	5° 9' N.
18	Mars	2 a.m.	"	6° 10' S.
22	Mercury	3 a.m.	"	2° 2' S.
23	Venus	noon	"	4° 40' S.

\* Below English horizon. † Daylight.

OCCULTATIONS:

Star	Magni- tude.	Dis- appears.	Angle from Vertex.	Re- appears.	Angle from Vertex.
Apr. 11	A Ophiuchi	4:7	2:58 a.m.	39°	3:8 a.m.
	{ Lerna	5:2	1:1 a.m.	1°	1:15 a.m.

THE SUN has latterly been showing an increase of activity. As I write—March 10th—there are at least 42 spots and pores upon his surface.

MERCURY is an evening star all the month, being at greatest elongation east (19° 23') at 1 a.m. on 11th, and setting about two hours after the sun near that date. After this it draws closer to the sun, coming into inferior conjunction at 10 a.m. on May 1st, its path being through Aries.

VENUS is also an evening star, its path taking it from Pisces through Aries into Taurus, so that at the end of the month—when it sets 1 h 45 m after the sun—it is south of the Pleiades.

MARS is a morning star in Aquarius, and later in Pisces, rising at the end of the month 1 h 45 m before the sun.

JUPITER is in opposition on April 9th. On 1st it is R.A. 13h. 36m., Dec. 0° 15' S., on May 1st, R.A. 13h. 13m., Dec. 3° 8' N. Its path is therefore

towards the north-west, just north of the 4th-magnitude ζ Virginis.

JUPITER is almost at its best for this year southing as it does a little before midnight. The equatorial belts are much contrasted, the southern being dark and dense, and apparently double through a part of its length, the extremities of the double portion being noticeable with quite small telescopes as distinct elbows. The northern belt is quite lacking in the density of its companion, besides having quite a different tint.

SATURN rises about a quarter of an hour before midnight at the beginning of the month, and two hours earlier at the end. Situated in Ophiuchus, 8° north-east of Antares.

URANUS rises at 9.45 p.m. on 22d, when it is situated just more than 1° south-east of the beautiful double star, β Scorpii.

NEPTUNE must be looked for early in the evening, when it will be found a little west of 114 Tauri.

THE Zodiacal Light may be observed this month following the line of the ecliptic, after sunset.

METEORS may be looked for about 11th, 12th, 19th and 20th.

RED STARS IN POSITION DURING APRIL:

Star	R.A.	Dec.	Magni- tude.	Color
α Boötis, Arcturus	14.11	19° 43' N.	1	Reddish yellow
ρ "	14.26	31° 30' N.	4	
B 328 "	14.19	26° 15' N.	7.5	Variable
B.A.C. 4628 Canes Ven.	13.46	35° 15' N.	6	
68 Virginis	13.22	12° 10' S. ±	5	
γ Hydræ	13.12	22° 20' S. ±	4	
R "	13.23	22° 36' S. ±	4-10	Variable

THE SOLAR ECLIPSE.—All the observers seem to have had the most exceptional good fortune in making their observations. The attempt to obtain spectroscopically the rotation of the corona proved a failure. The remarkable amount of light present during totality was a noticeable peculiarity. The totality, however, came to an end four seconds earlier than was expected.

SINGULAR OBJECT.—In the "Astronomische Nachrichten," No. 3,477, Dr. Brendel, of Griefswald, Pomerania, tells how that Postmaster Ziegler and several others, on February 4th, saw a remarkable body, about 6' in diameter, crossing the sun's disc. The ingress was at 1h. 10m. and the egress at 2h. 10m. Berlin mean time. The direction being towards the north-west, it can scarcely have been Dr. Waltemuth's supposed second moon which he predicted to be in transit on the 3rd. The object is said to have been visible for nearly a quarter of an hour before reaching the disc, and for nearly an hour after leaving it. Unfortunately the Doctor did not observe the object himself.

A SINGULAR "nebula" has, according to Rev. T. E. Espin's Circular, No. 46, from Wolsingham Observatory, under date of February 16th, been discovered by that observer. It is a "remarkable object, hitherto unrecorded, discovered on January 16th, and seen on three other nights. It is elliptical, 1' long, major axis 336', and rather resembles some obscuring medium than a nebula, and is, I believe, unique." It is situated R.A. 4h. 36m., Dec. N., 50° 44' (epoch 1855). It was discovered with a 6-inch achromatic, and has been observed with a 7½ inch at Edinburgh

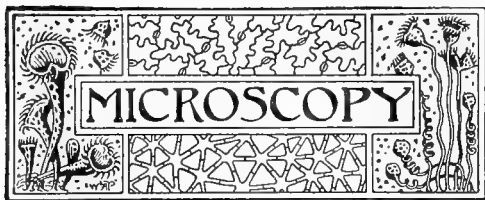

CONDUCTED BY J. H. COOKE, F.L.S., F.G.S.

To whom Notes, Articles and material relating to *Microscopy*, and intended for *SCIENCE-GOSSIP*, are, in the first instance, to be sent, addressed "J. H. Cooke, Thorndale, Lincoln."

**MICROBIOLOGY.**—M. Duclaux, the Director of the Pasteur Institute, has just issued a new work in three volumes on "General Microbiology." Vol. i. contains forty chapters, and includes a history of the action of ferments and of the different interpretations that have been put upon these from time immemorial. Pasteur's work is treated in great detail, and at the end of each chapter there is a notice of the published works that have reference to the subjects treated. Vol. ii. consists of a study of diatheses, poisonous substances and viruses; while the third volume treats especially of alcoholic and other fermentations.

**MANCHESTER MICROSCOPICAL SOCIETY.**—The work that has been done by this Society during the past month has been of exceptional interest. On March 3rd Mr. W. H. Pepworth gave an illustrated lecture on the slime fungi, "*Myxomycetes*," after which Mr. A. H. Tabor exhibited a specimen showing an apparent malformation of one of the joints in antenna of a crane-fly. On February 17th the Mounting Section met, and Mr. W. Moss gave a demonstration on the dissection, preparation and mounting of the radulæ of various species of British *Hyalinia*, and Mr. E. Ward described the best methods for mounting in glycerine jelly.

**OUR INVISIBLE FRIENDS AND FOES.**—The bacteria known now number 560 species, according to a London Institution lecture by Professor W. B. Bottomley, and practically our entire knowledge of these has been worked out since 1830 through the influence of Pasteur. Of the harmful species there are only about forty. Bacteria are found everywhere in the air and in our homes. They are so minute that 250,000,000 could be accommodated on a penny postage stamp, and they multiply with incredible rapidity. It is estimated that a human being takes in by respiration 30,000 germs each day, or 100 millions a year. Not only are most of them harmless, but they give flavour to butter, cheese, game, etc., and they are the scavengers of nature. They are absolutely necessary for the "round of life."

**STEREUM HIRSUTUM.**—Professor H. Ward has cultivated the mycelium of *Stereum hirsutum*, Fr., obtained from spores on sterilized wood, and after several months the cultures developed yellow bosses, which proved to be the hymenophores bearing the basidia. He points out in the "Proceedings of the Royal Society," p. 286, that this fungus has not hitherto been made to produce spores in cultures, and that Basidiomycetes generally have rarely been made to do so. The actions of the mycelium on the wood of *Æsculus*, *Pinus*, *Quercus* and *Salix* have also been examined for the first time, it is believed, with pure cultures. Anatomical and histological details with figures are given in the complete paper.

**A NEW MICRO-OBJECTIVE.**—The most powerful microscopic objective yet made is a one-tenth-inch mono-bromide of naphthalene immersion lens, made by Zeiss. Its numerical aperture is 1.60, and it has resolved, or made visible, a detail only  $\frac{1}{200000}$ th of an inch in width.

**COMPOSITION OF PEAT.**—Peat owes its origin almost always to that particular kind of moss which is commonly used for packing plants, and is known as sphagnum moss, although its formation may be afterwards carried on by heather, lichen and other plants. The explanation of this is seen when one examines the minute structure of this moss. Its leaves are folded in such a way as to give it a great capacity for holding water. If one goes further and examines a section of the leaf with the microscope, one again finds an adaptation for taking up water in the spongy nature of the dead cells lying between the living tissues of the leaf, the internal cavities being connected by canals with the exterior. No water is so full of animal life as that of a *Sphagnum* bog, great numbers of desmids, diatoms, protozooids, and other varieties being found. It is remarkable that the same species are everywhere associated with this moss, the *Sphagnum* of even Spitzbergen offering no exception.

**PREPARATION OF CRYSTALS.**—The determination of the geometrical and physical constants of crystals affords many opportunities for delicacy of manipulation, and for exactitude in observations. M. Tassin, in the course of a review of the various methods for preparing crystals for microscopic examination, groups them under the three heads—solution, sublimation and fusion. In the first class, crystals of a substance are prepared from its solution in a liquid by evaporating and cooling, by the reaction of soluble compounds, or by chemical changes in general. To secure crystals by fusion, either with or without pressure, it is necessary to prepare a solution of the substance in a molten magma, or to slowly cool a homogeneous magma. To obtain the crystals by the former method, crystallization must proceed as slowly as possible, and the removal of the crystals should preferably be effected when the solution is at its minimum temperature. Crystals desired for measurement must be quickly and completely dried in order to prevent corrosion or etch figures forming.

**MECHANISM OF PROTOPLASM.**—From "Natural Science" we learn that Professor A. L. Herrera has experimented with the object of explaining by mechanical principles some of the phenomena observed by Dr. Fol in the fertilization of the eggs of echinoderms. A thin layer of olive oil was allowed to float on the surface of water contained in a plate and a little yolk of egg then dropped into the middle glided easily upon the oil. On the approach of any pointed body the yolk rose into a bubble, resembling the cone of attraction observed by Fol before the penetration of the spermatozoid into the vitellus. The emission of pseudopodia, which fell back into the yolk as soon as the attractive force was removed, was noted in some cases, and with albumin the phenomenon was still more remarkable, a coin brought near the drop causing it to become slowly distorted as it was attracted by the metal, while subsequently it became pear-shaped. The analogy with the natural phenomena is described as being complete, the oil or less dense liquid representing the albumin, while the drop of yolk serves for the vitelline sphere.

**THE HARVEST BUG.**—Referring to the intolerable discomfort caused by the harvest bug, the "Comptes Rendus" tells us that the identity of the acaroid mite which gives rise to the "bumps" by burying itself in the skin, has been satisfactorily determined. M. Brucker has examined specimens taken from human beings during the last autumn, and has defined them as the hexapod larvæ of *Trombidium gymnopteron*. The same animal in the larval form has been found by the author on a rat and on a blackbird, as well as on many plants, especially on kidney beans. As other Trombidian larvæ may, in different localities, attack man, it is well to note that those reported on were obtained from Semur-en-Auxois (Cote d'Or), where this autumn plague is specially troublesome.

**MICROMETER MEASURING APPARATUS.**—Those of our readers who have experienced a difficulty in accurately estimating the size of minute objects with the ordinary micrometer will be interested in the accompanying sketch of an apparatus that has been designed by Mr. J. S. Curtis, of the United States Geological Survey, and which is used by him, with the aid of the microscope, for the quantitative determination of silver. The measuring apparatus is very simple in construction, and may be used with any microscope that is fitted with crossed hairs in tube or eyepiece. It consists of two metallic plates, one above the other, to which a motion parallel to one cross hair can be given as well as across it. These two plates are fastened upon a third plate, which is attached to the shelf of the microscope. The accompanying diagram shows the arrangement and mode of movement of these two plates. The letter *a* designates the plate upon which the object is placed. This plate has a motion parallel to the vertical cross hair given to it by means of the screw *s* and the ratchet *r*, and it moves between the side plates *b b*. This plate *a*, the side pieces *b b*, the screw *s* and the ratchet *r* all rest upon a second plate *f f*, which moves between the side pieces *c c*, across the vertical hair line. The motion from side to side is given to both the upper and lower plate by means of the micrometer screw *t*. This screw has 100 threads to the inch, and the micrometer *m* is divided into 100 parts, so that each division of the micrometer represents one ten-thousandth part of an inch. The screws *e e* hold the clamps *u u*, which are used to fasten the main plate of the micrometer to the shelf of the

microscope stand. Considerable practice is needed to accustom the eye to the apparatus, but as far as accuracy of measurement is concerned, it leaves little to be desired.

**PHOSPHORESCENCE OF WOOD.**—The phosphorescence of decaying wood proves to be due to minute vegetation, instead of to purely chemical causes, as some have supposed. The mycelium of some undetermined fungus from pine has been cultivated by Kutscher, a German biologist, in decoctions of beech bark and agar-agar, the result being a white, brilliantly luminous growth.

**SIZE OF BACTERIA.**—At a lecture on Bacteriology given by Mr. L. Atkinson before the Pharmaceutical Society, it was stated, with the object of affording some relative idea of the extreme minuteness of bacteria, that the tongue of a fly when flattened out is one-sixth of an inch long. Seen on a six-foot screen the measurement will be seventy-five inches, an enlargement of 450 diameters, or,

estimated superficially, 250,000 times larger. This amplification will not, however, enable us to see a trace of most bacteria, many of them only measuring from  $\frac{1}{30000}$ th to  $\frac{1}{300000}$ th of an inch. The power necessary to enlarge them to the size of ordinary printers' type would, in the same ratio, enlarge the fly's tongue to nearly 600 feet, or one and a-half times the height of St. Paul's Cathedral.

**FORMATION OF GOLD NUGGETS.**

—The theory that gold nuggets have been deposited from a solution around a nucleus has been a subject of microscopic investigation by Professor A. Liversidge, the Australian mineralogist. He finds that etched sections of nuggets show more or less crystallization, often large and well-defined crystals, sometimes with inclusions of quartz and other impurities, but never concentric layers. Gold that had been fused had a similar crystalline structure. He does not think this necessarily proves that native gold has been in a melted condition, but believes that it has been deposited from solution, and usually in veins and cavities, although possibly around a nucleus.

**FORAMINIFERA.**—Soldani has shown that one and a-half ounces of limestone from Cascina, in Tuscany, contained 10,454 fossil forms of forams, and many of them were so minute that 500 weighed only a grain. An ounce of sand from the Antilles was shown by D'Orbigny to contain 3,840,000 specimens.

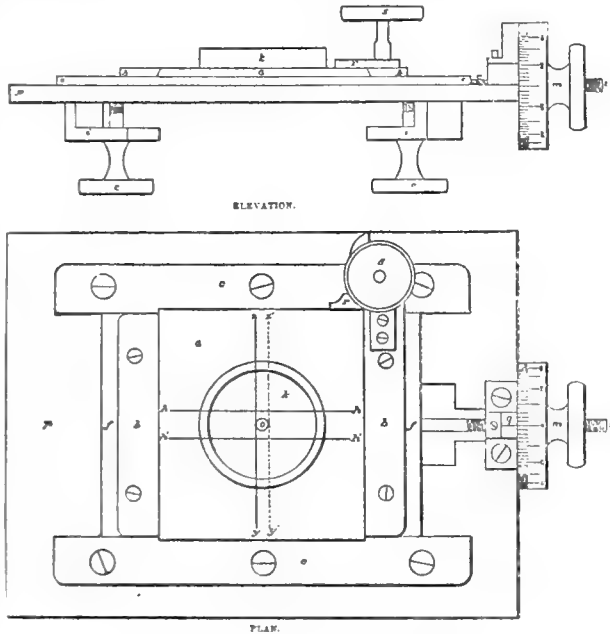

A MICROMETER MEASURING APPARATUS.

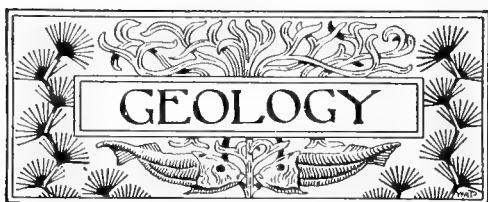

CONDUCTED BY EDWARD A. MARTIN, F.G.S.

To whom all Notes, Articles and material relating to Geology, and intended for SCIENCE-GOSSIP, are, in the first instance, to be addressed at 69, Bensham Manor Road, Thornton Heath.

**CHEADLE HEATH OAK.**—The huge oak which was recently exhumed during the progress of the Stockport sewage works, cannot in the accepted use of the word be described as a fossil tree. It is interesting, however, as evidence of the comparatively recent period, in which the rainfall is thought to have been greater than now, and when probably all over the country remains of the immense forests were being imbedded in the *débris* of the land then forming. It is a huge trunk, and still possesses great boughs, on the surfaces of which is a layer of partially carbonized bark, reminding one of the carbonized bark which covers the "coal-pipes," or standing trees in many a coal-mine.

**CHALK ROCK.**—As knowledge accumulates in regard to any stratum, zone, or formation, there are never wanting those who, dissatisfied with previous titles, invent new and perhaps more correct designations. Chalk Rock, sometimes called the zone of *Holaster planus*, has also been called the *Reussianum* zone from *Heteroceras reussianum*; but surely there is no good and sufficient reason why Mr. Wm. Whitaker's old accepted title should not still stand. It is well perhaps to zonate the stratum when tabulating the whole series of zones in the Chalk, but standing alone the Chalk Rock seems to deserve a special name, owing to its being a well-defined horizon, and of hard nodular composition.

**EROSION IN THE NILE VALLEY.**—Professor Hull has called attention to two great periods of erosion in the Nile Valley, the first of which was during the Miocene period, after the elevation of the Libyan region at the close of Eocene times, and the second during a "pluvial" period extending from late Pliocene times into and including the Pleistocene. The course of the river appears to be through escarpments of the granitic and schistose rocks of Assouan Nubian Sandstone, Cretaceous Limestone, and Eocene Limestone. Professor Hull observes that in places, the line of erosion of the primæval Nile was directed by dislocations of the strata. The unconformity of the Nubian Sandstone upon the granites and schists of Assouan is noticeable, and it is apparent that different parts of the Nubian Sandstone are of varying ages. An examination of the terraces of the Nile Valley shows a second line of terraces at a height varying from fifty to a hundred feet above the lower one, which is flooded at the present day. The second terrace is devoid of vegetation, and its deposits have frequently furnished river-shells such as *Cyrena fluminalis*, *Aetheria semilunata*, *Unio*, *Paludina*, etc. The second terrace is traceable at intervals for a distance of between 600 and 700 miles above

Cairo. Two old river-channels have also been discovered, one at Koru Ombo, and the other at Assouan itself. Dr. Hull believes the second terrace and the old river-valleys to be due to the former greater volume of the river, and not to subsequent erosion of the valley. He gives evidence of the existence of meteorological conditions sufficient to give rise to a "pluvial" period, following in this respect other authors who have also considered that the volume of the Nile has been greater in former times.

**PHOSPHATIC CHALK.**—The phosphatic chalk described by Mr. A. Strahan from the horizon of the Chalk Rock at Lewes resembles in composition and microscopic character a similar deposit found at Taplow. At the latter place, however, it occurred at the top of the Upper Chalk, whereas the Lewes deposit, of course, occurs at the base of the Upper Chalk. At both places it consisted of brown phosphatic grains contained in a white, chalky matrix, which also included numerous pellets attributed to small fish, phosphatized foraminifera, chips of bone and fish teeth. It rested upon a hard, nodular chalk with white chalk beneath, traversed by branching pipes of the brown variety. These floors are thought to be associated with pauses or changes during the period of sedimentation.

**FORMATION OF BOULDER CLAY.**—Dr. Croll was evidently a strong believer in the formation of boulder clay by land-ice. Submergence had, in his opinion, but a small part in its formation. Opinions are still, however, very divided amongst glacialists. Dr. Croll says: "It is physically impossible that any deposit formed by icebergs could be wholly unstratified. Suppose a mass of the materials which would form boulder clay is dropped into the sea from, say, an iceberg, the heavier part, such as stones, will reach the bottom first. Then will follow lighter materials, such as sand, then clay, and last of all the mud will settle down in fine layers. *Unstratified* boulder clay. . . . must be the production of land-ice. . . . The notion that unstratified boulder clay could be formed by deposits from floating ice is not only erroneous, but positively pernicious."

**BRITISH JURASSIC BRACHIOPODA.**—We have received Part ii. of Mr. J. W. D. Marshall's "Notes on the British Jurassic Brachiopoda," reprinted from the "Proceedings of the British Naturalists' Society." Mr. Marshall points out the changes in classification which have been rendered necessary since 1884, the date of the publication of Dr. Davidson's "General Summary to the Brachiopoda," and the date of that great brachiopodist's death. *Terebratula* proper is first met with in Jurassic rocks, although *Dielasma*, a near ally, is found in Devonian, Carboniferous and Permian rocks. Eight to ten species of an allied genus *Liothyryna*, are found in existing seas. We note a useful feature in the etymology given of each genus described. The reasons are given for the founding in 1830 of the genus *Waldheimia*, King, which includes many forms hitherto classed as *Terebratula*. The author summarises in tabular form the approximate number of British Jurassic Brachiopoda, and finds that there are 241 species, fifteen doubtful species, and forty-four varieties. Of these, *Rhynchomella*, *Terebratula* and *Waldheimia*, show no less than eight-seven per cent. of the whole.



CONTRIBUTED BY FLORA WINSTONE.

**CLIMATE OF THE YUKON BASIN.** Professor William Saunders, LL.D., F.R.S.C., F.L.S., the Director of the Experimental Farms of Canada, has issued a pamphlet "On the Possibilities of Agriculture in the Yukon District." Up to the present time the information obtained is somewhat meagre, but enough has been gathered to show the method in which some success is likely to be gained. Attention is now chiefly directed to the Klondyke district of the Yukon, owing to its rich gold deposits. In these parts, Professor Saunders says: "The summer climate is too cold to admit of much being done in the way of growing grain, fodder plants or vegetables. From particulars obtained from the meteorological records for the season 1895-96, I find that in August, 1895, the thermometer recorded 32° F. and below five times, and 40° and below nine times. In September, 1895, it was at 32° F. and below eighteen times, and twenty-nine times it was at 40° and below. In May, 1896, the thermometer was at and below 32° F. eighteen times; and on the 1st, 2nd and 3rd of the month it was 5° above zero. It was at 60° F. and above only five times during that month; the highest point being reached on the 18th and 23rd, when the thermometer reached 62°. The rivers broke up from the 11th to the 17th of May and ran thickly with ice until about the 23rd, after which they were navigable. It snowed on one day and rained on four days that month. In June, 1896, the thermometer was four times at and below 32° F., and seventeen times at and below 40°, and ranged the greater part of the day-time from 40° to 60°. Seven times during this month the temperature went above 70° F., and once only, on the 30th of the month, it reached 80°. It rained on twelve days that month. In July, 1896, the hottest days were the 1st and 2nd, when a temperature of 81° F. was recorded. During the greater part of the month the temperature ranged from 40° to 70° F.; it was at 40° and below nine times, and the lowest temperature was 33° on the 27th. It rained on three days that month. In August, 1896, the highest temperature was 76° F. on the 14th, and seven times the thermometer recorded a temperature above 70°; twice it recorded 32° and below, and thirteen times 40° and below. The lowest temperature was on the 31st, when the thermometer registered 27 2/3° F. It rained on eight days during August. In September the possibilities for the growth of vegetation were very limited. Eight times the temperature ranged from 32° down to 48° F., and twenty-three times it was at 40° and below, the highest point reached being 63°, which was on the 17th. Only eight times during September was the thermometer above 63° F.; during the greater part of the month it ranged during the day from 40° to 60°. The summer season of 1897, as far as heard, was warmer than in 1896. Temperatures as high as 90° F. were observed in the shade in July, but this is said to have been an exceptionally warm and dry month." In the face of the exceedingly low

temperatures through the summer, and the frosts in the beginning of June and at the end of August, there does not appear to be much future for agriculture in that country. A certain amount of success, however, can be obtained, especially at the margins of rivers. There are some vegetables which do not require a long time to mature, and can therefore be grown fairly well in the district, such as early varieties of turnips and cabbages, radishes and lettuces. These do not grow to a large size, but they are of a sufficient growth for use. Spinach, early varieties of green peas, beets, carrots and some sorts of onions would probably grow, and rhubarb would make a very useful substitute for fruit in the early part of the season, if the roots were not killed by the severe winter. Many trials have been made to grow potatoes, but unless they are planted where they are sheltered, or have some special protection, they are likely to be cut down by the frost in August. Professor Saunders quotes from the Report of Mr. Wm. Ogilvie with regard to the planting of potatoes, he says: "A Mr. Patch tried to grow potatoes on the south side of Forty-mile River, but they were invariably killed by frost before they matured. He then sought a nook on the south side of the river where the sun did not get to them until towards noon. They were thus gently thawed out in the shade before the strong sun heat fell upon them and thus survived the action of the frost." Mr. Ogilvie also refers to the experience of Mr. Harper, at Fort Selkirk, on the Yukon. To preserve potatoes from frost, "he made a large covering of heavy ticking, and every evening, when frost threatened, he suspended this over the potato tops, and lifted it in the morning, and in this way he was fairly successful." Oats and barley have also been tried, but no instance is given of their growth having been successful. They grew tall enough to make good fodder for cattle, but the seeds would have to be brought in fresh every year, as the frost kills the grain before any kernels are formed. Dr. G. M. Dawson, Director of the Geological Survey of Canada, explored the Yukon district in 1887, and from his observations at that time, he is of opinion that no cereal crops can be successfully grown or ripened on the coastward side of the mountains; but at Telegraph Creek and in that vicinity, on the Sitkine river, and on the east side of the coast range, latitude 58°, wheat, barley and potatoes can all be grown with success with the help of irrigation. The production of these crops in that region would probably form an important source of supply for the mining districts, as it is about 900 miles nearer Dawson City than Vancouver or Victoria, and when the proposed railway is running it will be equally easy of access. The most suitable spots in which to grow vegetables are along the banks of rivers where the soil is warm and sandy. In his report for 1897 Mr. Ogilvie, in speaking of the agricultural capabilities of the Yukon basin, refers to a number of localities in the valleys of the different rivers where he considers it is possible crops might be grown. In the neighbourhood of Dawson City, on the Klondyke, and for about 200 miles up the Yukon, similar conditions of climate prevail. Professor Saunders gives a list of varieties of vegetable products which have been tried with success on the experimental farms in the North-West Provinces, and which he recommends for trial in the Eastern Yukon districts, as they mature in a short time.



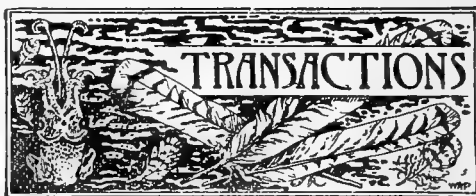
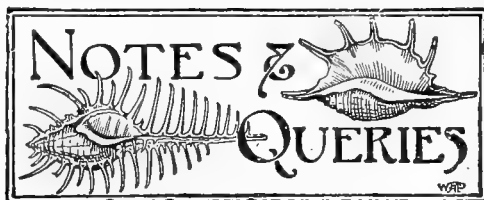

**THE BOOTH MUSEUM.**—The whole of the cases in the Booth collection of British birds, Dyke Road, Brighton, have been thoroughly cleaned during the past winter. The specimens have been examined and dusted; the museum, therefore, has a bright and fresh appearance, creditable to the curator. As we have before remarked, since this museum came under the control of the Borough Corporation of Brighton, additions are still made. Among the more recent are a pair of Ortolan buntings, obtained near Brighton; a beautiful dark variety of barn owl, said to be the Danish form, which was taken a year or two ago, near Shoreham, Sussex, and recently acquired by the Corporation. Among others to be shortly placed on view and at present under preparation by Messrs. Pratt and Sons, of Brighton, are a fine pair of hobbies taken in Sussex, though not very recently, and an interesting case of shorteared owls, old and young, the latter being the late Mr. Booth's own taking, but the adult example is recently from Scotland. There is also a Kentish example of the great grey shrike, which has been presented by its captor. The illustrated catalogue of the Museum was issued a short time ago as a new edition, and contains reference to most of the latest additions to the collections.—*John T. Carrington.*

**NORFOLK PLOVER IN SUSSEX.**—Mr. Pratt, of Brighton, recently showed me a particularly handsome specimen of this bird, which was obtained from near Shoreham. It has latterly become scarce in Sussex, although a comparatively few years ago it was somewhat abundant on the South downs, from which, however, it seems to have disappeared. Mr. Pratt tells me that the past mild season has not produced many ornithological rarities in the Brighton district.—*John T. Carrington.*

**SNAILS IN ROADSIDE HEDGES.**—I think the suggestion made by the Rev. J. W. Horsley about *Helix nemoralis* thriving in hedgerows by the roadside because of the lime found there from the road-dust, is correct. My experience goes to show that the roadside is the best hunting-ground for not only *H. nemoralis*, but *H. hortensis* and *H. arbustorum* also. At least this is so in Northants, where, until quite recently, the roads were repaired with limestone quarried in the neighbourhood. Some of the roads now are repaired with slag from the iron furnaces, and are not nearly so productive as formerly. I do not think that the abundance of *Nemoralis* is to be attributed to the fewer birds in roadside hedges; as many lovers of birds will bear me out in stating that the birds are as fond of the roadside as the snails, and, strange to say, are found near towns also, for nesting purposes. The nests of partridges and pheasants are always carefully searched for in the spring by the gamekeepers and others, as it is well known they prefer the roadside for their nests. The reasons are not far to seek. The first is because they can obtain the dust bath so necessary whilst incubating, without leaving eggs long enough to cool. A second is for the sake of food contained in horse droppings.—*C. E. Wright, Kettering.*

**ROYAL METEOROLOGICAL SOCIETY.**—At the meeting of this Society held on Wednesday evening, March 16th, at the Institution of Civil Engineers, Mr. F. C. Bayard, LL.M., President, in the chair, a lecture on "Photographing Meteorological Phenomena" was delivered by Mr. A. W. Clayden, M.A., Principal of the New College at Exeter, who gave details of his experiences as Secretary of a Committee of the British Association. After referring to the extreme value of photographic methods of recording the movements of instruments, the lecturer spoke of the real importance of preserving photographic records of all sorts of unusual meteorological phenomena, and emphasized the necessity of companion photographs showing the same scene under normal conditions. It was suggested that meteorologists throughout the country should co-operate with the Royal Meteorological Society in securing such records. The phenomena of the lightning discharge, as distinguished from those of a single flash, were next described and illustrated by a number of lantern slides. Some of the puzzles offered by lightning photographs were next alluded to, and the lecturer stated that he had repeatedly found that a single discharge lasted several seconds. Mr. Clayden then spoke of the "black" flashes shown in photographs, and described the steps by which, some years ago, he was led to the proof that they were merely a photographic phenomenon, but one which still remains unexplained. Passing on to a consideration of cloud photography, the various methods in use were explained, and a large number of lantern slides were exhibited, in some of which the clouds were shown on a background of blue sky in nearly their natural colours, a result obtained by the employment of suitable developers on a specially prepared plate. The method employed at Exeter by the lecturer for the measurement of cloud altitudes was fully described. This differs from all the others in using the sun as a reference point. Mr. Clayden then spoke of the difficulty in getting good pictures of cirrus clouds, and described the methods dependent on the polarization of the blue light of the sky, but expressed a conviction that polarization had nothing to do with their efficiency, which was really due to a general lessening of brightness which enabled the exposure to be properly judged.

**NORTH LONDON NATURAL HISTORY SOCIETY.**—Thursday, March 3rd, 1898, Mr. R. W. Robbins, President, in the chair. Mr. L. J. Tremayne opened a debate, entitled, "Are Man and his Works a proper subject of study for a Natural History Society?" arguing that man was merely an animal, that civilization did not make him otherwise, and that the works of every other animal were studied by naturalists. He said that everything connected with man was technically within our scope, though it was no doubt convenient to reject many things as a general rule. Mr. C. Nicholson opposed, arguing that man, as soon as he becomes civilized, is beyond our scope. The apparent civilization of certain of the lower animals



was really only due to instinct. Mr. Bacot contested the latter point, and adduced several instances to prove that many of the acts of the lower animals were brought about in the same way as those of man. Mr. W. H. Barber supported the affirmative, and Mr. Prout supported the negative. Miss Nicholson thought that, while it was perhaps difficult to draw a distinct line, there was a pretty general understanding as to what was within the pale of natural history and what beyond it, and that understanding had better be adhered to. A vote was taken, and the negative was carried by twelve to eleven.—*L. J. Tremayne, Hon. Sec.*

## NOTICES OF SOCIETIES.

## GEOLOGISTS' ASSOCIATION OF LONDON.

*Excursions and Conductors:*

- April 7 to 12.—Bridport and Weymouth. Rev. Prof. J. F. Blake, M.A., F.G.S.  
 " 23.—Reading, Berks. J. H. Blake, F.G.S.  
 May 7.—Rugby, Warwickshire. Beeby Thompson, F.G.S.  
 " 14.—Ayot, Hertfordshire. A. E. Salter, B.Sc., F.G.S.  
 " 21.—W. P. D. Stebbing, F.G.S.  
 " 28 to 31.—Aldeburgh, Suffolk. W. Whitaker, F.R.S., Pres. G.S., F. W. Harmer, F.G.S., and E. P. Ridley, F.G.S.  
 June 11.—Godalming, Surrey. T. Leighton, F.G.S.  
 " 18.—Crowborough and Eridge, Kent. R. S. Herries, M.A., F.G.S., and Dr. G. Abbott.  
 " 25.—Sudbury, Suffolk. J. W. Gregory, D.Sc., F.G.S.  
 July 9.—Isle of Sheppey, Kent. W. Whitaker, F.R.S., Pres. G.S., and T. V. Holmes, F.G.S.  
 " 16.—Worlingham, Surrey. W. Whitaker, F.R.S., Pres. G.S.  
 " 28 to Aug. 3.—Birmingham, Nuneaton, Dudley, Lickey, Cannock, etc. Prof. C. Lapworth, LL.D., F.R.S., W. W. Watts, M.A., F.G.S., W. J. Harrison, F.G.S., and W. Wickham King, F.G.S.  
 Sept. 10.—Gravesend, Kent. G. E. Dibley, F.G.S.

Further particulars from *Horace W. Monckton, Sec. (Excursions)*, 10, King's Bench Walk, Temple, E.C.

## BATTERSEA FIELD CLUB AND LITERARY AND SCIENTIFIC SOCIETY, Public Library, Lavender Hill, S.W.

- April 28.—"The Geology of Surrey," with special reference to scenery. G. W. Young.

*Excursions:*

- April 23.—Oxshott Heath and Stoke D'Abernon. Conducted by the Hon. Sec.  
 May 28.—Hayes and Keston Commons. Conducted by the Hon. Sec.  
 June 11.—Anstiebury and Leith Hill. Conducted by G. W. Young.  
 " 25.—Whole-day Excursion to Sea-side.  
*Hon. Sec. E. J. Davies, Marney Road, Clapham Common*

## LAMBETH FIELD CLUB AND SCIENTIFIC SOCIETY, St. Mary Newington Schools, Newington Butts, S.E.

- April 4.—Lecture: "Phases of Oceanic Life," with lantern illustrations. A. P. Wire.  
 " 11.—Easter-Monday Outing: Coulsdon and Chalton.  
 " 23.—Visit to Zoological Gardens.  
 May 2.—Lecture: "Spring Flowers." E. J. Davis.  
 " Outing. Particulars to be announced.  
 " 30.—Whit-Monday Outing. Reigate.  
 June 6.—Annual Meeting  
 " 11.—Outing. Shirley Hills and Addington Woods.  
 " 25.—Outing. Perivale and Horsendon Hill.  
*Hon. Sec., H. Wilson, 14, Melbourne Square, Hrixton Road.*

## NORTH LONDON NATURAL HISTORY SOCIETY.

- April 16.—Visit to Kew Gardens.  
 " 21.—"Lepidopterous Larvae." A. Bacot.  
 May 5.—Discussion: "Nebulae." Opened by C. Nicholson.  
 " 21.—Half-day Excursion to Epping Forest.  
 " 27 to.—Excursion to the New Forest—leader, L. J. Tremayne.  
 " 30.—Alternative whole-day Excursion to Shere.  
 June 16.—"The Cauzalidae." E. M. Dadd.  
 " 18.—Whole-day Excursion to Deal—leader, L. J. Tremayne.  
 Visitors will be cordially welcomed at all meetings and excursions.  
*Lawrence J. Tremayne, Hon. Sec.*

## SOUTH LONDON ENTOMOLOGICAL AND NATURAL HISTORY SOCIETY.

- April 14.—"British and Japanese Lepidoptera Compared." R. South, F.E.S.  
 " 28.—"Hemiptera." Edward Saunders, F.L.S., F.E.S.  
 May 12.—"South European Lepidoptera." A. H. Jones, F.E.S.  
 6.—Geological Lecture with Lantern Illustrations.

## SELBORNE SOCIETY—CROYDON AND NORWOOD BRANCH.

- April 7.—Social Evening. Exhibits, etc., will be welcomed Rev. F. E. J. Bird, *Vice-President*, will speak Seneca Hall, 8 p.m.  
 " 21.—Annual Meeting, at Public Hall, Croydon. Subject "The New Forest." Rev. H. E. H. Bull, M.A. Lantern slides. 8 p.m.

## NORTH KENT NATURAL HISTORY AND SCIENTIFIC SOCIETY.

- April 6.—"Lepidoptera." S. J. B. Pine.

## PRESTON SCIENTIFIC SOCIETY.

- April 6.—"Methods of Fishing and Fish Culture on our Coasts." R. L. Ascroft (Member of the Lancashire Sea Fisheries Committee).  
 " 20.—"Biography of a Fern." W. Clitheroe.  
 \* Illustrated by oxy-hydrogen lantern.  
 Lecture Hall, Cross Street, Winckley Square, 8 p.m.  
*W. Hy. Heathcote, F.L.S., Secretary, 47, Frenchwood Street.*

## NOTTINGHAM NATURAL SCIENCE RAMBLING CLUB.

Conductors of Rambles:  
*Geology*, J. Shipman, F.G.S.; *Botany*, W. Stafford.

- May 7.—Geology. Meet at tram terminus, Trent Bridge, 3 p.m., to Radcliffe, etc., for study of Trent Valley formation. Fare and tea, 1s. 3d.  
 " 21.—Botany. Meet at tram terminus, Mansfield Road, 2.30 p.m., for Edward's Lane and Mapperley.  
 June 4.—Geology. Meet under clock, G.N.R. Station, 2.15 p.m., for Kimberley: coal measures, magnesium, limestone, etc. Fare and tea, 1s. 9d.  
 " 18.—Botany. Meet at Midland Station, 2.15 p.m. Attenborough and Burton.  
 July 2.—Geology. Meet at Midland Station, 1.15 p.m., for Mansfield: sandstone, etc. Fare and tea, 3s. 3d.  
 " 16.—Botany. Meet at Midland Station, 1.15 p.m., for Hucknall.  
 " 30.—Geology. Meet in front of University College, Shakespeare Street, 2.30 p.m., drive to East Leake and Gotham: marls, shales, gypsum, etc. Fare and tea, 2s. 6d.; tickets to be taken before July 30.  
 Aug. 13.—Botany. Meet at Emmanuel Church, Woodborough Road, 2.30 p.m., for Lamley Dumbles.  
 " 27.—Geology. Meet at Sneinton Baths, 2.45 p.m., for Colwick for Bunter Pebble Beds, Keuper strata, etc.  
 Sept. 10.—Botany. Meet at Lodge, Waverley Street entrance, to examine Arboretum and Pater Herbarium at University Museum.  
 Oct. 29.—Annual Meeting and Exhibition, 4.15 p.m., Natural Science Laboratory, University College.  
*Hon. Sec., W. Bickerton, 187, Noel Street.*

## SCARBOROUGH FIELD NATURALISTS' SOCIETY.

- April 7.—"A Chat on Shells." R. H. Barker.  
 " 21.—Short Papers. Members.  
 May 5.—"Anemones." J. C. Harrison.  
 " 16.—Y.N.U. Excursion to Clapham for Bowland, Notts.  
 " 19.—"An Ardent Entomologist." T. W. Lownsbrough.  
 " 30.—Y.N.U. Excursion to Doncaster for Balham and Sandal.  
 June 2.—"Chara and Nitella: their structure, life and beauty." D. W. Bevan.  
 " 16.—"Stems." Miss Major.  
 " 18.—Y.N.U. Excursion to Hovingham and Wiggan-thorpe.  
 " 30.—Marine Conversation.  
 Meetings held in the Museum at 8.15 p.m.  
*Hon. Secs., E. R. Cross and H. Herbert, 75, Prospect Road.*

## TUNBRIDGE WELLS NATURAL HISTORY SOCIETY.

- April 8.—"Problems in Plant Life." Benj. Lomax, F.L.S.  
 May 6.—Annual Meeting.  
 Ordinary Meetings in the Literary Society's Library, 37, Pantiles, on Friday evenings, at 8. Miss Cooke,  
*Hon. Sec., 19, Guildford Road.*

## METROPOLITAN SCIENTIFIC SOCIETIES.

The following is a list of societies in the London district devoted to natural science, with hours and places of meeting. They may be visited with introduction from a Fellow, Member, or Secretary. Will secretaries send additions or corrections

- ANTHROPOLOGICAL INSTITUTE OF GREAT BRITAIN, 3, Hanover Square. Second and fourth Tuesdays at 8.30 p.m., November to June.
- BATTERSEA FIELD CLUB AND LITERARY AND SCIENTIFIC SOCIETY. Public Library, Lavender Hill, S.W. Thursdays, 8 p.m.
- CITY OF LONDON COLLEGE SCIENCE SOCIETY, White Street, Moorfields, E.C. Last Wednesday in each month, October to May, 7.30 p.m.
- CITY OF LONDON ENTOMOLOGICAL AND NATURAL HISTORY SOCIETY, London Institution, Finsbury Circus. First and third Tuesdays, 7.30 p.m.
- CONCHOLOGICAL SOCIETY, LONDON BRANCH, St. Peter's Rectory, Walworth. Irregular meetings. Rev. J. W. Horsley, President, will answer enquiries.
- CROYDON MICROSCOPICAL AND NATURAL HISTORY CLUB, Public Hall. Third Tuesdays, October to May, 8 p.m.
- DULWICH SCIENTIFIC AND LITERARY ASSOCIATION. Fortnightly lectures Lordship Lane Hall, second and fourth Mondays, 8.15 p.m., from October, for winter season.
- EALING NATURAL SCIENCE AND MICROSCOPICAL SOCIETY. Victoria Hall, Ealing. Second and last Saturdays. October to May, 8 p.m.
- ENTOMOLOGICAL SOCIETY, II, Chandos Street, Cavendish Square. First Wednesday, October to June (except January). Third Wednesday, January, February, March and November, 8 p.m.
- GEOLOGISTS' ASSOCIATION, University College, Gower Street. First Friday, 8 p.m., November to July.
- GEOLOGICAL SOCIETY OF LONDON, Burlington House, Piccadilly. First and third Wednesdays, 8 p.m., November to June.
- LAMBETH FIELD CLUB AND SCIENTIFIC SOCIETY, St. Mary Newington Schools, Newington Butts, S.E. First Mondays all the year and third Mondays in winter, 8 p.m.
- LINNEAN SOCIETY OF LONDON, Burlington House, Piccadilly. First and third Thursdays at 8 p.m., November to June.
- LONDON AMATEUR SCIENTIFIC SOCIETY, Memorial Hall, Farringdon Street, E.C. Fourth Friday in each month, October to May, 7.30 p.m.
- LUBBOCK FIELD CLUB. Working Men's College, Great Ormond Street, Bloomsbury, W.C. Excursions second Sundays, Meetings following Mondays, 8 pm.
- MALACOLOGICAL SOCIETY OF LONDON, meets in Linnean Society's Rooms, Burlington House. Second Friday each month, November to June, 8 p.m.
- MINERALOGICAL SOCIETY. Meets in rooms of Geological Society, February 4th, April 14th, June 23rd, November 17th, 8 p.m.
- NONPAREIL ENTOMOLOGICAL AND NATURAL HISTORY SOCIETY, 99, Mansfield Street, Kingsland Road, N.E. First and third Thursdays, 8 p.m.
- NORTH KENT NATURAL HISTORY AND SCIENTIFIC SOCIETY. St. John's Schools, Wellington Street, Woolwich. Alternate Wednesdays, 7.30 p.m.
- NORTH LONDON NATURAL HISTORY SOCIETY, North-East London Institution, Hackney, Downs Station. First and third Thursdays, 7.45 p.m.
- QUEKETT MICROSCOPICAL CLUB, 20, Hanover Square. First and third Fridays, 8 p.m.
- ROYAL BOTANIC SOCIETY OF LONDON, Regent's Park. Second and fourth Saturdays at 3.45 p.m.
- ROYAL HORTICULTURAL SOCIETY, 117, Victoria Street, S.W. Second and fourth Tuesdays, except December to February; 2 p.m. on show days, which vary.
- ROYAL METEOROLOGICAL SOCIETY, 22, Great George Street, Westminster. 3rd Wednesday, November to June, 8 p.m.
- ROYAL MICROSCOPICAL SOCIETY, 20, Hanover Square. Third Wednesdays, October to June, 8 p.m.
- SELBORNE SOCIETY, 20, Hanover Square. No winter meetings.
- SIDCUP LITERARY AND SCIENTIFIC SOCIETY, Public Hall, Sidcup. First and third Tuesdays, October to May, 8 p.m.
- SOUTH LONDON ENTOMOLOGICAL AND NATURAL HISTORY SOCIETY, Hibernia Chambers, London Bridge, S.E. Second and fourth Thursdays, 8 p.m.
- SUTTON SCIENTIFIC AND LITERARY SOCIETY, Public Hall Chambers. Second and fourth Tuesdays, 8 p.m.

WEST KENT NATURAL HISTORY, MICROSCOPICAL AND PHOTOGRAPHIC SOCIETY. Meets in School for Sons of Missionaries, Blackheath, third Wednesday, in December, fourth Wednesdays in October, November, January, February, March, April, May, 8 p.m.

ZOOLOGICAL SOCIETY OF LONDON, 3, Hanover Square. First and third Tuesdays, 8.30 p.m., November to August.

## NOTICES TO CORRESPONDENTS.

TO CORRESPONDENTS AND EXCHANGERS.—SCIENCE-GOSSIP is published on the 25th of each month. All notes or other communications should reach us not later than the 18th of the month for insertion in the following number. No communications can be inserted or noticed without full name and address of writer. Notices of changes of address admitted free.

BUSINESS COMMUNICATIONS.—All Business Communications relating to SCIENCE-GOSSIP must be addressed to the NASSAU STEAM PRESS, LIMITED, 86, St. Martin's Lane, Charing Cross, W.C.

SUBSCRIPTIONS.—Subscriptions to SCIENCE-GOSSIP, at the rate of 6s. 6d. for twelve months (including postage), should be remitted to the NASSAU STEAM PRESS, LIMITED, 86, St. Martin's Lane, Charing Cross, W.C.

Strictly Editorial communications, *i.e.*, such as relate to articles, books for review, instruments for notice, specimens for identification, etc., to be addressed to JOHN T. CARRINGTON, 1, Northumberland Avenue, London, W.C.

NOTICE.—Contributors are requested to strictly observe the following rules. All contributions must be *clearly* written on one side of the paper only. Words intended to be printed in *italics* should be marked under with a single line. Generic names must be given in full, excepting where used immediately before. Capitals may only be used for generic, and not specific names. Scientific names and names of places to be written in round hand.

THE Editor will be pleased to answer questions and name specimens through the Correspondence column of the magazine. Specimens, in good condition, of not more than three species to be sent at one time, *carriage paid*. Duplicates only to be sent, which will not be returned. The specimens must have identifying numbers attached, together with locality, date and particulars of capture.

THE Editor is not responsible for unused MSS., neither can he undertake to return them, unless accompanied with stamps for return postage.

## CHANGE OF ADDRESS.

James Burton, from 9, Agamemnon Road, to 39, Ingham Road, West Hampstead, N.W.

## EXCHANGES.

NOTICE.—Exchanges extending to thirty words (including name and address) admitted free, but additional words must be prepaid at the rate of threepence for every seven words or less.

WHAT offers in shells, crustaceans, echinoderms, for whole and half-plate prints and negatives of photo-micrographs, and whole-plate negatives of Welsh and English scenery?—H. W. Parritt, 8, Whitehall Park, N.

DIATOMS, selected, spread and unmounted, for exchange; correspondence invited; 1½-inch or 1-inch objective wanted.—R. Borrows, 18, Pensbury Street, Darlington.

OFFERS wanted for a small collection of fossils and minerals; exchange for good quarter-plate camera and apparatus.—John B. Mayor, St. Alban's Villas, Heaton Chapel, Manchester.

SCIENCE-GOSSIP, unbound, vols. from January, 1880, to August, 1893, inclusive, Old Series, and from March, 1894, to December, 1895, inclusive, New Series. What offers? Perfect condition.—E. H. Robertson, Greenhouse Lane, Painswick, Gloucestershire.

DENES' MEDIUM.—Will send a bottle of Denes' Medium for botanical specimens in exchange for one good microscopical slide.—A. H. Nicholson, Carlton House, Greenbank Road, Darlington.

CAN exchange for other slides or for mineral specimens, duplicates of foraminifera, polycystinae, spread diatoms, sponge spicules, etc., or photo-micrographs of minerals, diatoms, etc., offered; lists exchanged.—Robert Pettigrew, 44, Mosley Street, Manchester.

WANTED, offers for the whole of SCIENCE-GOSSIP, 1865 to 1897; first 28 volumes in publisher's cover, remainder unbound.—G. P. Bonny, 20, Wellington Road, Stoke Newington, London, N.

To exchange, choice sets of American eggs with data, including booby, frigate bird, white ibis, least bittern, Inca dove, prairie sharp-tailed grouse, parakee, Abert's towhee, Bendire's thrasher, and many others. Wanted, offers in British eggs.—Charles Jefferys, Tenby.

MICROSCOPE, by Browning, Strand; movable stage, ¼ and 1-inch objectives. Exchange or sale.—J. Proctor, 44, Amphill Square, N.W.

## HAS THE MOON AN ATMOSPHERE?

BY FRANK C. DENNETT.

AT first, the question whether the moon has an atmosphere appears very easy to answer, yet it is one which cannot be replied to off-hand, and would be met by different authorities with absolutely contradictory replies.

Dr. Johnston Stoney and those who think with him will tell us that the atmosphere of any celestial body must depend upon its mass, and the pulling power or gravitation exerted thereby. The

five-prism direct-vision spectroscope, could none of them observe any widening of the lines of the spectrum, such as might be expected from the presence of an atmosphere. An observation by Mr. (now Sir) William Huggins of the occultation of the spectrum of  $\epsilon$  Piscium, brought to the notice of the Royal Astronomical Society in January, 1865, appeared also to strengthen the view that there could be no appreciable atmosphere to our satellite.



MAP OF THE MOON. (I)

molecular velocity of even the slowest of the components of our own atmosphere, carbon di-oxide, amounts to 1.6 miles per second at  $0^{\circ}$  C. The mass of the moon is  $\frac{1}{81}$  that of the earth being 10. This would only exert sufficient gravitational power to hold a gas having a velocity of 1.5 miles, or less, per second.

This view seems borne out by many observations which have been made. For instance, at the solar eclipse of 1869, Professor Young, observing with a spectroscope of five prisms, angle  $4^{\circ}$ , and in that of 1874, Mr. E. J. Stone, with two dense flint prisms of  $60^{\circ}$ , and Mr. A. C. Ranyard, with a

The observations of stellar occultations seem to give generally the impression that there is no refractive phenomena such as might be expected. Perhaps one of the most interesting of these observations was that made photographically at Harvard by Mr. Edward S. King, when on the 6.1 magnitude star 26 Arietis was occulted on February 25th, 1898, but no trace of any dimming of the star disc could be discovered, notwithstanding that the method employed seemed to favour the discovery of the presence of the slightest obscuring medium.

On the other hand, nearly all observers who have made the moon an object of persistent study seem to come to the conclusion that there is an atmosphere, otherwise the phenomena observed

Illustration prepared from a drawing by Mr. F. K. Miller, published in the *Monthly Bulletin of the Astronomical Society*, 1898, p. 10.

are altogether perplexing. Let us look to some of the facts to which they call attention. Long ago Schröter—whose telescopes included a nineteen-inch reflector—and Gruithuisen believed that they detected traces of a faint twilight extending beyond the cusps. The Rev. T. W. Webb and others have suspected something of the same sort, and twenty years since, the brothers Henry, with the large refractor of the Paris Observatory, observed faint but decided traces of this appearance. Further, at Arequipa the same thing has been observed frequently. Such observations, however, need the very finest conditions of our own atmosphere.

Sometimes a peculiar phenomenon known as projection is observed at the occultation of stars: this has been supposed by some to be due to the refraction of a lunar atmosphere, the star being apparently projected on to the disc of the moon. Simultaneous observations, however, seem to force the conclusion that the effect is an illusion probably produced by an error in focussing; the real error lying in the eye itself being affected by the different brilliancy of the star and moon, in the same way that, when observing the sun, a telescope exactly focussed on the limb will be found to require a slight readjustment if turned to an object in the centre of the disc.

Writing of occultations, however, reminds me of those of planets occasionally observed. In 1857, August 7th, 1889, and June 14th, 1896, during the progress of the occultation, a narrow dark band was observed on the planet at the edge of the moon's limb. Were the observations only visual, some doubt might be thrown upon them. In the later occultation, photographs were taken—particulars of which will be found in Vol. xxxii. Part 1 of "Annals of the Harvard Observatory"—which not only showed the dark band, but also, both before disappearance and after reappearance, showed a halo around the planet's disc. Professor Pickering has kindly written to say that "it is impossible to show the dark band on Jupiter on paper satisfactorily, though it is well seen in the negative." Another remarkable thing was noticed, both visually and in the photographs, at the occultation of the same planet, August 13th, 1892: Professor Pickering found a slight but decided flattening of the planet's limb as it approached the moon; the distortion did not exceed 1", therefore he considers the actual density of a lunar atmosphere must be very slight—not exceeding  $\frac{1}{10000}$  part that of our own.

Both Hahn and Gruithuisen saw faint nebulous streaks of light within the dark side of the moon close to the terminator or boundary between the enlightened portion and the shadow, which the latter believed to be hazy clouds. Schmidt, April 25th, 1844, saw just such a glimmering patch, of a bluish colour, to the south-east of *Picc*, in a position where no mountain peak exists, as this lofty peak

was disappearing beyond the terminator. Mädler had seen something similar within lofty ring-plains. In 1871 three observers in different parts of England noticed a similar phenomenon within the ring *Plato* on the north border of the *Mare Imbrium*. Schmidt was convinced that what he saw was not a telescopic "ghost," nor caused by the secondary spectrum.

Another phenomenon has been frequently met with by persistent workers: portions of the disc have become "fogged," so that it has been impossible to "get at" the details, whilst the rest of the disc has been crisp and sharp. This has been observed in the *Mare Serenitatis*. In the ring *Plato*, some sixty miles in diameter, Bert and others noticed phenomena in connection with the visibility of craterlets, light specks and streaks on the floor, which seem only explicable by accepting the presence of an atmosphere. Similar observations have latterly been made at Arequipa in Peru, where the Harvard observatory has a branch establishment, the atmospheric conditions being of the best. A singular phenomenon is noticed about this crater—that the longer it is exposed to the sun's rays as they rise upon it, the darker the floor becomes.

The *Mare Crisium* is subject to peculiar changes: "On rare occasions it has been seen by Schröter, and in part by Beer and Mädler, speckled with minute dots and streaks of light. Something of this kind I saw with a fluid achromatic, July 4th, 1832, near I. Quarter. A similar appearance was noticed by Slack, and Ingall, 1865" (2). Mr. Slack says that the delicate bands of light radiated "from the vicinity of a small mountain near Picard. Several light spots were also noticed in parts of the same sea which are usually dark." The reason that these objects are so seldom visible seems impossible of explanation, unless the presence of an atmosphere be admitted. Another phenomenon has been noticed by the writer upon the surface of this *Mare*. A little outside its eastern border there is a brilliant crater called *Proclus*, from the brilliance around which a number of bright streaks radiate; there being apparently four centres of radiation. Some of these streaks extend a considerable way across the *Mare*. One of the shorter of the streaks, radiating from a point just off the south-west wall of *Proclus*, passing a little to the north of *Picard*, is not always in the same position with regard to a small crater on the *Mare* known as *Picard E.*, as if the streak had a motion from north to south.

A similar motion has been suspected from east to west in the case of the streak from *Tycho*, which crosses the *Mare Serenitatis*, and upon which the crater *Bessel* is situated.

(2) "Celestial Objects for Common Telescopes," by Rev. T. W. Webb. Third Edition. p. 82.

On the north-west border of the *Mare Serenitatis* there is a fine ring called *Posidonius*, whose floor is at a higher level than the plain outside the walls. Near the middle of its floor there is a smaller crater, A, which Schmidt once found without its shadow, and which Schröter once found with a sort of grey veil in place of the shadow.

Besides these special features, and in many more that could be added, in which there seems evidence of atmospheric phenomena, Professor Pickering has noticed that on observing the moon when near new, the shadows of the mountain ranges always appear fringed with a penumbra; but although he considers this is evidence in favour of an atmosphere, the density of it cannot be more than that of the earth—at an altitude of about forty-three miles.

When the moon's diameter as measured with the micrometer is compared with the diameter determined by the occultations of stars, the measured diameter appears to be about  $\frac{1}{4}$  too great. Perhaps, however, irradiation may have something to do with this difference.

The "Selenographical Journal" of the former Selenographical Society, from which nearly all the notes given with respect to spectroscopic observations, and also those of Gruithuisen and Schmidt, are drawn, said: "An important observation was made at the Observatory of Melbourne during the solar eclipse of February 2nd, 1878, when the observers endeavoured to ascertain whether the lines of the solar spectrum itself, seen in close proximity to the moon's advancing edge, suffered

any change or not; a decided thickening of many of the lines close to the moon's edge was distinctly observed." This observation seems to settle the question with which our paper started, and to answer it with a distinct affirmative.

There is, however, one more point to be considered. Our moon is not the only one in the system, and those of Jupiter do not differ greatly from it, and at the same time are easy of observation. There seems practically no doubt that, like our own moon, they revolve on their axes once during their orbital revolution. The mass of the outer satellite is about the same as that of the moon, the third is heavier, whilst the other two are lighter. Notwithstanding this, they all, but most especially the outer, show variations in brightness absolutely unaccountable unless we conceive the fact that there are considerable variations in the amount of vapour present in their atmospheres. Unfortunately, the photographs of the spectra of these bodies do not include the red region. Sir William Huggins kindly writes, quoting from Vogel's paper in the "Astrophysical Journal" for March and April, 1895, so far as Jupiter's satellites are concerned: "From my early observations the lines in the red seen in the spectrum of Jupiter were also probably present in the spectra of the satellites; so far no observations appear to have been made elsewhere on the subject." It is, however, to be hoped that the observations lacking may be soon made with some of the modern mighty light-grasping telescopes.

60, Lenthall Road, Dalston, N.E.

## WHERE AMBER IS FOUND.

BY R. DICKSON-BRYSON, B.A., F.P.S., F.R.As.S.

AMBER is chiefly brought from the Baltic. The prolific centre is the peninsula of Samland in Eastern Prussia. There amber mining is carried on to a large extent. Ingenious contrivances for sifting the precious mineral thrown up by the sea are also employed. These ejections occur regularly during the November and December storms. From what repositories amber proceeded, and to what geological epoch it belonged, and how it came to be engulfed in the Baltic, were problems that long baffled research.

Amber is generally supposed to be a marine product, and to exist in huge radial masses at the bottom of the Baltic. This was Dr Berendt's opinion. He advanced the theory that at a time when Northern Germany was covered with the waters of the Tertiary Sea, the amber forests grew upon islands situated north of the present coast-line of Prussia. Here the resin accumulated and was ultimately engulfed.

It is to Professor Zaddach, of Königsberg, we owe almost all the knowledge of the subject we possess. He explored the strand hills of Samland, and discovered three systems or groups of layers: the upper one being of diluvial marl and sand, the middle one a bed of lignite, and the lowest one a layer of greensand. All the strata contain amber, the upper one in isolated pieces, while the greensand contains a stratum four or five feet thick of very dark earth, called "blue earth," in which amber occurs so plentifully that an area of fifty or sixty square rods yields several thousand pounds of the precious mineral. This is the great amber mine of the world, and the only place where the geological conditions admit of an advantageous study. It is nowhere else found in its primary place of deposit.

Zaddach's investigations showed that the "blue earth" stratum, which in many places sinks to depths inaccessible to the miner's shafts, also runs

horizontally on a level with the sea, where it is exposed to the action of the waves. It was discovered recently that this exposed position of the amber stratum extends to a distance of some fifty miles. This is the source of the "marine" amber. The waves constantly wash this stratum and bear the amber from its bed towards the shore, where it is collected.

The amber tree belonged to the flora of the Tertiary period, when Europe was a vast archipelago, the sea spreading over parts of England, France, Belgium, Holland, Germany, Hungary, and Italy. A vast continent existed in the north, which extended in the Arctic regions beyond Spitzbergen, and was united with Greenland and North America, while to the south and east it was united with Iceland and the British Islands.

The southern boundary of this continent was considerably enlarged at the close of the secondary period by the deposits of the Cretaceous Sea; and by repeated upheavals a broad belt was formed embracing the islands of Rügen, Bombohn, Jutland and the Danish islands, and the space now occupied by the Baltic. This newly-formed land was separated from the rest of Europe by a great sea-arm called the Tertiary Sea. On the borders of this northern continent a luxuriant vegetation was developed. Here grew the trees which produced the amber of commerce.

The climate at the time of the formation of the amber was sub-tropical. In Spitzbergen the American incense-cedar (*Libo-cedrus decurrens*) flourished, and the sequoia (*Sequoia sempervirens*). The sequoia, now confined to California, grew all over Europe during the Miocene period, together with its relative, the *Glyptostrobus*, a cypress now found only in China and Japan. The fragrant magnolia, the date-plum tree, the oak, pine, poplar and walnut, *Salisburia*, *Planera*, and the elegant *Thujaopsis*, now indigenous to Eastern Asia only, flourished in Greenland; while the vine, the tulip tree, the elm and the mammoth tree flourished in Iceland.

The amber forests consisted largely of coniferous trees. Professor Göppert distinguished thirty species. This wealth of resiniferous trees leads to the conclusion that amber was the product of several species of conifers, the most common being a "tree of life," resembling the American *Thuja occidentalis*. Of leaf-bearing trees may be mentioned several species of oak, willows, beeches, a birch, an elder and a poplar, and a camphor tree whose living representatives are confined to China and Japan and the adjacent islands.

Professor Göppert named the amber-pine *Pinites succinifer*, and has determined 163 species of plants found in amber specimens, which he has classified into sixty-four genera and twenty-four families.

The *inclusa* in amber are of great interest.

Although they furnish an incomplete picture of the flora and fauna of the primeval forest, they nevertheless supply some features characteristic of that early epoch. The amber fauna are rarely found elsewhere as fossils, and many represent extinct forms. Among the spiders, the genus *Arachia* differs from the living species by the position of the eyes, the length of the jaws, and by the head, which is distinctly separated from the breast. A feather, described by Berendt, shows that the amber forest contained birds, and a solitary tuft of hair proves the existence of Mammalia. Frogs, lizards, and fishes found in amber have been introduced by artificial means for purposes of deception. Bubbles of air and even drops of water occur.

The amber resin was shed in very different stages of liquidity: sometimes it was glutinous, sometimes it fell in drops from the branches, yielding the drop and icicle forms; sometimes it fell on leaves, the forms of which it preserves with remarkable delicacy.

Many generations of the amber pine lived and died, and vast quantities of the resin must have accumulated. How these accumulations finally broke up is uncertain. It is supposed to have been brought about by some sudden cataclysm, which tore loose a great part of the resin and threw it into the Samland Gulf. It is probable that the production of amber belongs to several periods in the earth's formation, and that the resin remained buried in the soil of the higher parts until the diluvial sea flooded the entire north, and, with the ruins of the devastated country, scattered the deposit far and wide. The submersed amber was covered with layers of greensand, marl and other substances brought down by the rivers, until the sea was filled up. Samland was first laid dry, then the rest of Prussia, the dry land appearing like islets which were ultimately connected with one another.

Walkerburn, N.B.; March, 1898.

ASSEMBLING MOTHS.—Mr. Herbert Williams gives in the April "Entomologists' Record" some interesting notes on the attractions of a female *Lasiocampa quercus* (large egger moth). This, soon after emerging from its cocoon, he put into a tin larva box with one side perforated. The box was placed in a tightly fitting black leather brief bag, and he started for a locality where the moths occurred. On arriving at about three o'clock in the afternoon, Mr. Williams was shortly surrounded with males of this species of moth, and could have taken more than a hundred if he had required them. This is no unusual fact, but a further note is well worthy of attention. Nine days later Mr. Williams went over the same ground with the same bag, and in it the same larva tin. The female moth had not been in it during the nine days previous, nor was it then; but the males came to the bag all the same. Whatever be the power of attraction, it had remained in the empty box for more than a week.

## COLORATION AND VARIATION OF BRITISH EXTRA-MARINE MOLLUSCA.

BY ARTHUR E. BOYCOTT.

(Continued from page 325.)

NOT much is known as to any variation in the body pigments correlated with variation in shell coloration. Mr. Bowell has, however, made the following very interesting observations: "There are two pretty constant sizes of melanin globules in the pigment cells of *Tachea*: *A* are about  $3\ \mu$  diameter, *B* about  $0.5$  to  $0.75\ \mu$ . *A* occur only in small numbers, or not at all, in *lilacinæ*, *castaneæ* and light purplish banded *fasciatae*, *B* being numerous. Both *A* and *B* occur in ordinary *fasciatae*, but in very dark specimens *A* greatly preponderates in numbers."

L. E. Adams<sup>(1)</sup> has exhibited an albino of *Cryptomphalus aspeusis*, with pink eyes<sup>(2)</sup>, with an unusually dark shell, from Northampton. This is an important specimen, as showing a pigmented shell without pigment being apparent in the mantle.

*Limnæa stagnalis* produces a pigment which is chiefly found in specimens which are functionally male, and appears to be derived from some part of the sexual apparatus. When hot water is poured over a functionally male adult specimen<sup>(3)</sup>, the fluid is ejected from the genital orifice. It quickly turns from rose colour to light purple on exposure to the air, and finally fades. Traces of it may often be seen on the columellæ of specimens in collections. Similar pigments seem to be secreted by *Planorbis complanatus*, *Limnæa palustris*, and, in a less degree, by *L. fetegera*<sup>(4)</sup>; also, perhaps, by *Paludina contecta*<sup>(5)</sup>. To these are probably due the vars *tincta*, Jeff., *roscolabiata*, Jeff., and, in part, *corvus*, Gmelin, of *Limnæa palustris*, as well as *roscolabiata*, Wolf, of *L. stagnalis*.

*Tachea hortensis* often has a pink, and *Cryptomphalus* a violet, peristome; and, less frequently, the rib of several species, e.g., *Fruticicola hispida*, *Xerophila caferata*, is tinged with pink. This appears to depend very much on the weather. Last year (1896) such cases appeared commonly in the autumn in Herefordshire, after the exceptionally rainless eight months, from January to August. J. G. Jeffreys long ago observed that "the beautiful pink gloss observable

on the mouths of *X. fisana* and *X. virgata* is entirely owing to the action of and their exposure to the sun. In the specimens found in more sheltered situations, the colours and markings are much fainter, and sometimes altogether wanting"<sup>(6)</sup>. It is well known that Draparnaud produced a similar result by starvation. It is a matter of common observation that parts of the sexual apparatus, e.g., the dart-sac, are often tinged in *Tachea* and other snails with a pale pink or purplish pigment<sup>(7)</sup>.

The inside of *Unio pictorum* is often tinged with a beautiful pink colour: of 136 specimens from the Hereford Waterworks (1896), sixty-one per cent. (excluding very young ones) were pink inside with a bright yellow periostracum, while the remaining thirty-nine per cent. were white inside with a dull, greenish-yellow periostracum. It seems that the difference, which was very striking, is probably physiological, not morphological, and may be sexual. Rogers has attributed a similar phenomenon in a canal near Manchester to the "refuse at the bottom" of the water<sup>(8)</sup>, and the form has been frequently recorded. The nacre in *U. tumidus* may be similarly tinged, but the pink is not quite the same, and I have more often seen this latter species with white or pale violet-purple nacre than pink. In *U. tumidus* the pink is stronger in hot seasons, and may be increased by "over-cooking"<sup>(9)</sup> (E. W. W. Bowell).

By the kindness of Mr. J. T. Nance, of Balliol College, Oxford, some of the white and pink *U. pictorum*, from Hereford, above referred to, have been analysed, and he is of opinion that the red colour is due to a trace of manganese<sup>(10)</sup> too small to estimate quantitatively; at any rate the red shell gave a strong, and the white shell no, manganese reaction. Both shells contained a trace of iron, and it seems fairly certain, judging from its

<sup>(1)</sup> Trans. Linn. Soc. xvi. (1813), p. 334. O. F. Muller (Verm. Hist. II. (1774), p. 69, says, "margo roseus."

<sup>(2)</sup> On the whole, however, warm, dry years (such as 1896 in Herefordshire) seem to produce a tendency to albinism on the whole shell, in, e.g., *T. hortensis*, cf. "British Naturalist," N.S. (1894) p. 121.

<sup>(3)</sup> L. E. Adams, *op. cit.*, p. 148.

<sup>(4)</sup> Manganese seems not very uncommon in mollusca: e.g., in *Pinna* there is much Mn, and Cu is almost absent from the blood ash, the suggestion being that manganese, as copper does, may play the same part in the blood that iron does in vertebrate blood. See A. E. Griffith's "Physiology of Invertebrates" (1892), pp. 143, 145, etc. The blood of *Unio* contains copper (Görup-Bronze), but not, according to Halliburton, hæmocyamin: Journ. of Physiol., vi. (1885), p. 317. On the general rôle of manganese (and other metals) in the animal body see J. Gaube, "Compte de Mineralogie Biologique" (1897), pp. 158 ff.

<sup>(1)</sup> Journ. of Conch., viii. (1896), p. 267. Mr. Adams has met with a similar condition in *Limax maximus*, L. *op. cit.*, p. 222.

<sup>(2)</sup> The retina in Cephalopoda is of a red colour (not due to rhodopsin). A. Sheridan Lea, "Chemical Basis of the Animal Body" (App. to M. Foster's Physiol., 1897, p. 265).

<sup>(3)</sup> Cf. W. Nelson, Journ. of Conch., I. p. 216.

<sup>(4)</sup> W. E. Collinge, "Zoologist" (3), xl. p. 209. "*Aplexa hypænum* var. *rufa* also exhibits this pink tinge very markedly." E. W. W. B.

<sup>(5)</sup> L. E. Adams, "Manual," p. 123. It is not made at all clear by the author whether either of the crimson fluids is hæmocyaminiferous.

solubilities, that the red colouring was not organic in character<sup>(10)</sup>.

I should like here to mention Mr. Horsley's note in SCIENCE-GOSSIP (p. 254). His paper in the Malacologist for last July (vol. vi., August, 1897, p. 21) was published after the present communication had been written; but I must apologise for the oversight which prevented me noticing his interesting suggestion in its proper place, as I had fully intended to do. I cannot think that his explanation is satisfactory. In the first place I observe the same predilection for hedge-banks in *Tachea* in all kinds of soils, and on all kinds of roads. I have especially in mind a lane which is seldom less grassy than an averagely bare meadow, but on the banks of which *Tachea* abounds. The banks with which I am chiefly acquainted are on the side of roads which have a surface composed of hard bluish basalt from the Cleve Hills. I cannot obtain any information at this moment as to its chemical composition, but judging from other similar rocks, its percentage of lime is not in all probability high.

Another objection seems to me to lie in the fact that it is not known—that is, to the best of my belief—that ordinary inorganic calcium salts are of direct use to snails in making their shells. It would seem much more probable that they obtain it through the intermediary of plants, which often contain a considerable amount, and where it probably exists as an integral part of the proteid molecule<sup>(11)</sup>. The amount of calcium in a plant, it is true, varies to a certain extent with the amount of lime in the soil. The objection to this view, and it is, I think, a very serious one, is that a snail would often have to consume a prodigious amount of plant to get the necessary calcium. The amount it consumes seems to be very large, and it may be large enough<sup>(12)</sup>. Finally, I can call to mind several fields with which I am very familiar which have been on occasions treated somewhat freely with lime stuffs, but the grassy hedge-banks remain as snailless as before. The matter seems to me to be one of vegetation: we find *Tachea* abundantly in places where the plants are varied, and in a sense rough and coarse, and often rather sparse, e.g., on many roadside hedge-banks, on sand-hills, in disused overgrown quarries, on railway banks; but we do not find them in any quantity in grassy meadows, nor on hedge-banks which are thoroughly grassy, nor often on such hedge-banks even where

<sup>(10)</sup> Though rather foreign to the subject, Mr. Nance's main analysis of a white shell may be thought worth publishing:—Water, 1'34; Organic matter 4'00; CaCO<sub>3</sub>, 93'01; Al<sub>2</sub>O<sub>3</sub>, 1'58 = 99'93. The analysis was made some twelve months after cleaning out the shells.

<sup>(11)</sup> Cf., e.g., E. A. Schäfer, "Text-Book of Physiology," i. (1898), p. 886.

<sup>(12)</sup> Exact data are difficult to get, but it would appear that about two kilos. of ordinary average grasses would supply the lime for a large *Tachea nemoralis*.

<sup>(13)</sup> As has already been pointed out by C. E. Wright, Science-Gossip, N.S. iv. p. 336 (1898).

they abut on the highway. *Tachea* seems to revel in variety in more than one way, and to be very precocious as well. There also seems to be more humus in such places; though, seeing that *Tachea* is mostly absent from the places where humus chiefly abounds, this cannot go for much.

It seems to me that Mr. John T. Carrington's suggestion in the same place is hardly in accordance with observation<sup>(13)</sup>. Thrushes and blackbirds do not seem to shun the roadsides much, as, indeed, is testified by the frequency of their nesting in these public places; and they will come to get food into the very near proximity of man and his works.

While on this subject, I may mention that I often think I can detect a very marked predilection in *Cryptomphalus aspersus*, and, to a less degree, in *Fruticicola rufescens* for the neighbourhood of human dwellings or buildings. I do not know whether this is in accordance with the observations of others. It may be only that *Cryptomphalus aspersus* are so very easy to see when they are in the situation to which one always turns to find them—at the bottom of an old well. But it seems to me that there is more in it than that.

This article must conclude for the time being my series on the coloration and variation of our land and fluviatile mollusca. I hope, however, to return to the subject in these pages at a future date.

*The Grange, Hereford; April, 1898.*

## AUTOMATIC COPYING.

WE have lately had the opportunity of seeing some excellent work done by the Automatic Cyclostyle, an instrument invaluable to students of natural science for circulating the results of their work among their fellow students or otherwise. The great simplicity of the machine is such that, with very little practice, the most perfect copies can be taken of either writing, typewriting, drawings or music. It is not necessary that one coloured ink alone be used, for compositions in several colours can be obtained with the machine. In operation no great skill is required,

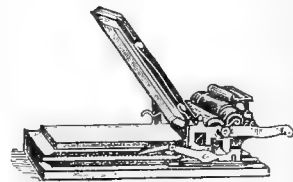

as the only necessity is to write on the prepared paper with a special pen and without ink, as the pen perforates the paper, so making a stencil. This is placed in a frame, a handle is turned, and out come copies as rapidly as they can be replaced, up to a couple of thousand if required. We can well recommend this machine to secretaries of scientific societies and others who have occasion to prepare manifold copies of notices or other documents. The address of the makers, who will supply all particulars, is The Cyclostyle Company, 34, Snow Hill, London, E.C.



## BRITISH INFUSORIA.

BY E. H. J. SCHUSTER, F.Z.S.

## PART I.—FLAGELLATA EUSTOMATA.

(Continued from page 309.)

IN the last number some species of the genera *Euglena* and *Phacus* were described. I will now add descriptions of three further species of these two genera before proceeding to others.

*Euglena spirogyra* Ehrenberg.—The body of this animal is elongate and sub-cylindrical, and when fully extended is about seven or eight times as long as broad and from 95 to 180 microns in length. The anterior end is slightly truncate and bears a slender flagellum of about the same length as the animal itself. The posterior end is produced into a transparent sword-like projection. The colour varies in shade between bright green and brown.

Fig. 1.—*Euglena spirogyra* ( $\times 500$ ).

The nucleus is round and nucleolate and sub-central in position. Anterior and posterior to it a pair of large, round, amylaceous corpuscles may be found, which Ehrenberg, in trying to prove the high organization of the Infusors, considered to be testes. The arrangement of the contractile vacuole and its reservoir is as in *E. viridis*. The cuticular surface bears evenly-arranged oblique rows of minute beard-like projections. The movement is slow and steady.

This animal was discovered by Ehrenberg in the year of the accession of William IV.; it was found again by Dujardin in the Seine, on October 11th, in the year of Her Majesty's accession.

One does not come across this species nearly so frequently as the others described, because it never occurs in vast shoals like *Euglena viridis*, and is a clean-living animal, preferring running to stagnant water, freshness to putrefaction.

*Phacus pleuronectes* Müller.—This animal occurs principally in stagnant water, the body is compressed and leaf-like in shape, about one and a-half times as long as broad, and bears a tail-like projection about a quarter of its own length, which is

directed obliquely upwards. The cuticular surface is smooth, or sometimes presents a finely striated appearance, especially when empty. The endoplasm is coloured bright green, and often contains a large spheroidal amylaceous corpuscle. The

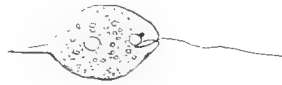
Fig. 2.—*Phacus pleuronectes* ( $\times 300$ ).

nucleus is posteriorly located and spherical in shape. The contractile vacuole is situated near the anterior pigmented eyespot or stigma, and often exhibits irregularly developed lateral branches. Size, 20 to 50 microns. *P. pleuronectes* was described by Müller as *Cercavia pleuronectes*, and was transferred by Ehrenberg to the genus *Euglena*, and afterwards by Nitzsch to the genus *Phacus* which was established by him.

*Phacus pyriformis* Ehr.—This is subfusiform or pear-shaped, about twice as long as broad. The body is continued posteriorly in an acutely pointed tail-like prolongation which is about equal to the body in length. The cuticular surface is marked with a series of oblique grooves, and owing to the

Fig. 3.—*Phacus pyriformis* ( $\times 350$ ).

tenuity of the animal both sets of grooves are seen at the same time, so as to present an appearance of coarse network. It is about 20 to 30 microns in length. This animal occurs fairly commonly in pond water. It swims slowly, turning on its long axis. The species was discovered by Ehrenberg in 1831 and described by him as *Euglena pyriformis*.

*Amblyophis viridis* Ehr.—The genus *Amblyophis* is very closely allied to *Euglena*, but differs from it in having the posterior extremity rounded and not produced into the tail-like expansion which forms such a well marked characteristic of the genus *Euglena*. Dujardin, Maximilian Perty and others considered that the type species *A. viridis* was merely a tailless variety of *Euglena viridis*, but Stein re-established the genus in the year 1878, and

W. Saville Kent, in his "Manual of the Infusoria," published shortly afterwards, supports Stein's view.

The body of *A. viridis* is elongate-ovate in shape, and is from eight to ten times as long as broad when fully expanded, and from 125 to 225 microns in length. The anterior end is transparent and obliquely truncate, and it is here that the red stigma is situated. Dujardin says that it is bilabiate, and that the flagellum springs from the upper lip, but probably it is pierced by a tubular pharynx, as in



Fig. 4.—*Amblyophis viridis* ( $\times 300$ ).

*Euglena viridis*, from the base of which this appendage has its origin. The posterior end is rounded. The endoplasm, except for the anterior portion, is coloured bright green, and bears numerous oval and rod-shaped amylaceous corpuscles. The green matter Ehrenberg considered to be composed of the animal's ova, the rod-like amylaceous corpuscles genital organs, and he called a globular mass situated under the stigma, which is probably in reality the reservoir of the contractile vacuole, the nervous ganglion. The contractile vacuole as in *Euglena viridis*. This animal is common in ponds and ditches, and moves in a slow and vacillating manner.

*Trachelomonas volvocina* Ehr.—This is a small green *Euglena*-like organism, enclosed in a smooth sub-spherical or ovate indurated sheath or lorica, which is red in colour and appears under the microscope as a crimson band surrounding the animal itself, and forming a pleasing contrast to its green-coloured endoplasm. This hard case is perforated at one point to allow the flagellum to pass through it, and round this hole a collar-like projection of varying size may be raised. The



Fig. 5.—*Trachelomonas volvocina* ( $\times 500$ ).

structural details of the organism are more or less the same as in *Euglena*; this aperture also serves as a means of entrance for food particles. While under ordinary circumstances all except the flagellum is enclosed within the lorica, yet it has been observed by Perty and Stein that under certain conditions the body squeezes out through the minute anterior aperture, and swims about

naked, or rather without its armour, like an ordinary little *Euglena*. "This feat," says Saville Kent, "appeared to Stein to be as difficult of achievement as the passage of the biblical camel through the needle's eye," yet we are led to infer that even this is possible. The diameter of the lorica is from 25 to 35 microns, and the flagellum, which is slender and somewhat difficult to see, may be as much as double or treble this in length. It is, however, readily seen on killing the animal with osmic acid.

This animal may be found in fresh water among confervae. It is sluggish in its habits, and often appears to lose its flagellum and settle down to rest; in fact I have observed quite as many in this condition as engaged in more or less active peregrinations. It is one of the most common of freshwater Infusoria, and yet for some reason or other it usually escapes notice in the various popular works on "Pond Life." Its small size and unobtrusive habits may perhaps account for this neglect.

*Trachelomonas hispida* Perty.—This differs from *T. volvocina* in having the lorica ovate or elliptical, and covered evenly with minute points, or hisps, instead of being perfectly smooth; the red colour is also not quite so pronounced. I observed a

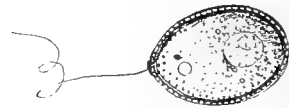

Fig. 6.—*Trachelomonas hispida* ( $\times 500$ ).

variety in which the hisps were more pronounced round the anterior aperture than in other parts. The length is from 22 to 48 microns and is from one and a-half to two and a-half times as great as the breadth. As in the former species, there is a collar round the anterior aperture which varies in depth.

*T. hispida* is as common as *T. volvocina*, resembles it in size, and is found in similar situations. It was described first by Ehrenberg, in 1832, under the name *Chaetoglena volvocina*, from specimens taken by him among confervae in the neighbourhood of Berlin; and, according to Stein, it is also identical with *Chonemonas hispida* and *C. schrankii* of Max. Perty

*Trachelomonas euchlova* Ehr.—The lorica is colourless and smooth, is oval or elliptical in shape, and is about one and a-half times as long as broad, the length being from 20 to 40 microns. The anterior aperture is produced into a short tubular obliquely projecting neck. This species was described by Stein under the name *T. lagenella*, and although he recognized that it was identical with *Lagenella*

*euchloris* of Ehrenberg, for some reason or other he did not retain the specific name. The genus *Trachelomonas* was established by Ehrenberg, and



Fig. 7.—*Trachelomonas euchloris* ( $\times 500$ ).

placed by Dujardin in the family Thécamonadiens, which he characterizes as follows: "Thécamonadiens.—" Animaux ordinairement colorés, revêtus

d'un tégument non-contractile, membraneux ou dur et cassant, et n'ayant pas d'autres organes locomoteurs qu'un ou plusieurs filaments flagelliformes." Owing to the fact that the various genera had only one feature in common, namely, the possession of a non-contractile sheath or lorica, they formed a most heterogeneous and unnatural assembly. The family was finally pulled to pieces by Stein in his "Organismus der Infusiorthiere," abtheilung iii. heft i. (1878), who, recognizing the affinity of the genera *Trachelomonas* and *Euglena*, placed it among the Euglenidae.

(To be continued.)

## THE EVOLUTION OF THE ANIMAL CELL.

BY JOSEPH SMITH, M.R.I.A., F.L.S.

(Concluded from page 321.)

**N**UCLEI in animals appear in the form of rounded objects, and are situated in the middle of the cells, but in some classes of cells, such as lymph corpuscles, etc., and in the epithelial cells of the gills of salamander larvae, no nuclei can be distinguished during life or until coagulation of the parts takes place, or until the parts have been submitted to the action of weak acids for the purpose of bringing the nuclei up. Amongst the lower organisms the nucleus may assume various forms, sometimes the form is that of a horse-shoe, as in some of the Infusoria, or of a twisted strand, as in the Vorticellae.

Another peculiarity of this object is, that the greater the bulk of protoplasm, *i.e.* material surrounding it, the larger the nucleus becomes. As a rule, amongst animals and plants one nucleus exists to each cell, but many of the lower organisms, such as the Infusoria, Myxomycetes, etc., are exceptions to it, possessing many nuclei in their cells. They are so minute as to be invisible, especially in the cells of the Myxomycetes, wherein they can only be distinguished by a special method of staining. The nucleus is made up chiefly of two constituting materials, nuclein or chromatin, and paranuclein or pyrenin, and these can be easily distinguished under a sufficiently powerful lens. The preponderating material in the nucleus is the chromatin, and it is the most characteristic proteid. Nuclein or chromatin is present in the heads of the spermatozoa. Paranuclein is also a proteid substance whose presence in the nucleus never fails. What its properties are and the manner of its vital functions we are ignorant of, since the rôle this substance plays in the vital phenomena has to be worked out. It, however, resists the action of all media—such as distilled water, very dilute alkaline solution, solution of salt, sulphate of magnesia, etc., which cause the nucleus, when treated with

any of them, to swell up. It is considered that nuclein and paranuclein form the two essential constituents of the nucleus, but besides these essentials, there are present linin, nuclear sap and amphipyrenin. The vital functions of these materials are less important, the linin forming the thread-like structure which frequently is seen in the nuclear cavity. The nuclear sap, generally present in large quantities, fills up the interstices left in the structures composed of linin, nuclein and paranuclein, and it is evidently functional in nourishing the nucleus.

Amphipyrenin is the term which has been applied to that substance, which forms the separating membrane of the nucleus from the protoplasm. This substance is as difficult to demonstrate as to settle the vexed question, whether the larger number of cells are enclosed by a membrane or not. It is, however, easily distinguished in the large germinal vesicles of many eggs, especially those of amphibians, wherein it is also somewhat dense, and on this account the nucleus can be extracted from immature eggs with facility. In other instances it is questionable whether any membrane exists, and Flemming (1) has failed to discover it in the blood of amphibians. Hertwig has also been unsuccessful in discerning it in sperm mother cells of Nematodes in a certain stage of development. Nuclein may manifest its presence in the form of fine granules, as large masses, as fibrils, as a framework, or in the form of honey-comb structure, and during the process of the vital phases it may develop into some other substance.

In formulating a definition of the nucleus, its shape must be disregarded. The great difficulty lies in describing the vital substances contained in it, exactly as in defining the cell, the greatest difficulty arises in describing the protoplasm. The nucleus

(1) "Zellsubstanz, Kern und Zelltheilung," Leipzig, 1892.

consists of "a mass of substances peculiar to it, and which to a certain degree differ from protoplasm, and may be distinguished from it."

In addition, there are present other bodies usually known as nucleoli, and these play a prominent part in the structure of the germinal vesicles of animal egg cells. They generally differ very materially in their tissue from the nuclei met with in ordinary tissues. These nucleoli may be easily distinguished in the large eggs of fishes, amphibians, reptiles, and the number of spots increase during the growth of the cell until a very large number are present. Whether this amplification is brought about by division is not at present known. The position of the nucleoli, or germinal spots, as they are generally termed—although the term is not correct, has not been satisfactorily worked out. It is, however, clear the rounded bodies more or less present in the nuclei of plants and animals have been classed together incorrectly under the name of nucleoli, as they show material differences amongst themselves<sup>(2)</sup>. Generally it is supposed these nucleoli are built up of two substances, and this structure has been observed to exist in *Helix*, *Tellina* and *Asteracanthron*, as also in the *Anodon*, but in the *Asteracanthron*, however, the feature becomes one of special interest, since the separation into two substances only begins to be visible when the germinal vesicle commences to break up. The resting nucleus may exhibit considerable variation in all its separate parts, according to the age or development of the cell. As the ovum matures a novel feature in cell evolution begins to be remarkable; it may be looked on as the final factor in perfecting the life-history or cycle of cell formation. The polar spindle, or pole corpuscle of the cell, as it is sometimes called, now becomes apparent. It is a very minute object, exists in the protoplasm of the cell, and is termed the centrosome. In cell structure it is of the greatest importance. Its functional vitality is exhibited in the economy of the cell, it is the cell centre, and its character during the development of the cell contents, after same have been subjected to fertilizing influences, is highly functional. Around this polar corpuscle the various cell contents arrange themselves. It is entirely a micro organism, and, as a rule, there is one pole corpuscle in each lymph cell; but there are exceptions to the rule, since in the epithelium of the lung, and in the endothelium

and connective tissue cells of the peritoneum of salamander larvæ, two of these corpuscles have been found lying close together in place of one, either in the immediate neighbourhood of the resting nucleus, or in the indentation of it, and immediately in contact with the nuclear membrane. This corpuscle possesses the faculty of being able to multiply itself by spontaneous division. Such are the component parts of the animal cell. In the first instance we have the existing vivified protoplasm in which, as time progresses, is noticed the resting nucleus. Within this in due course appears the nucleolus, or inner germinating spot. Other substances now manifest their presence, the functional characters of which may be regarded as passive until the advanced stages of the egg, *i.e.* fertilization, are reached; and finally we find existing the pole corpuscle. The cell now is complete, and awaits the consummating act which sets into motion that embosomed vitality which eventually leads to the development of the adult animal form.

It has been suggested that elementary organs exist which are not possessed of nuclei, and Haeckel at one time recorded two divisions in which no nuclear centre could be traced; not that such was correct, for the nucleus was invisible and could not be identified on account of its minuteness. Many of the plants, *e.g.* Algae, Fungi, Protozoa, Vampyrella, Polythalamia and Myxomycetes, all at one time illustrative of the non-existence of nuclear centres, are now demonstrated to possess nucleated cells. Since the discovery of the human ovum it is considered as indisputable that throughout the whole animal kingdom no example of cell without a nucleus can be given. It was against this assertion of the non-existing non-nuclear cell, that the blood of mammals was put forward as an illustrative example of the existence of such cells; but the blood of this group of animals contains no true protoplasm, and consequently no true nuclei. Moreover, they are not considered as true cells, but merely the products of the metamorphosis of the developments of former cells. Now it will be asked: what after all is essential to a cell? All that is essential to the cell, or elementary part, is matter—matter in a living state, germinal matter, and matter which is formed matter or material; with these is usually associated a certain proportion of matter about to become living—the pabulum or food. So that we may say in every living being there exists matter in three different stages: matter about to become living, matter actually living and developing, and matter which is formed and is therefore changeless.

Final causes are also introduced into the speculative theory surrounding the phenomena of organic life, and they are almost universally deemed to be the real ultimate cause of life. Some

<sup>(2)</sup> Flemming: "Zellsubstanz, Kern und Zellteilung," Leipzig, 1882. Carnoy: several papers in "La Cellule: Recueil de Cytologie et d'Histologie générale"—"La Cytodièse chez les Arthropodes," t. i.; "La vésicule germinative et les glottes polaires chez divers nématodes." See also "Conférence donnée à la Société belge de Microscopie," t. iii. Likewise, H. B. Lee, on "Carnoy's Cell Researches,"—Quart. Journ. Mic. Soc., vol. xxvi. p. 481-497. Zacharias: "Ueber den Nucleolus."—Botanische Zeitung, 1885. Oscar Hertwig: "Beitrag zur Kenntniss der Bedlung Befruchtung und Theilung des Thierischen Eis"—Morphol. Jahrbuch, 1, h. v.

attempts have been made to demonstrate that many, if not the whole, of these interesting problems resulting from the progressive growth of cell matter, some of which have been considered unapproachable, have admitted a natural solution or mechanical explanation by what has been termed non-purposive causes, in opposition to the hypothesis that the development of the germ cell to the final result—the adult form—was provided for by conscious purposive causes. Whatever this species of philosophy may ultimately aspire to, it is apparently a matter of indifference whether the final result is the outcome of a series of purposive causes or merely the completion of a cycle of non-purposive causes, necessarily working causes; since the ultimate end resulting from the working of such causes, whether of the so-called mechanical on the

one hand, or of the conscious purposive causes on the other, is the consummation of the adult structure. Assuming, on the other hand, that the mechanical influence is the case, the adult form being the ultimate end for which these causes, whether purposive or non-purposive, are working, design must very forcibly become prominent, since any of these causes set adrift of themselves might assume a degenerate process in the ordinary course of development. Whereas, it is found from investigation of the working of these causes, in whatever series they may be placed, that as beautiful a harmony amongst the various organisms exists, throughout those phases of development which follow immediately on the egg cell becoming fertilized, as existed in the evolution of the original animal cell or ovum.

*Latchford, near Warrington.*

## ORCADIAN RAMBLES.

BY ROBERT GODFREY.

(Concluded from page 315.)

### VI.—ON THE TRACK OF THE HEN HARRIER.

MY persistent ramblings in search of the harrier, found me on the 1st of June in an exceedingly wild district of the mainland, where the short-eared owl was common, as could be inferred from the number of castings containing remains of field-voles and of long-tailed field-mice, that lay scattered about everywhere. There, too, the red grouse appeared more numerous than in the districts previously visited. I had temporarily left all the common tribes of birds behind me, and was traversing a region so desolate that at times no life, not even a golden plover, was at hand, and I hoped here at length to bring to a successful issue my long hunt for the harriers. Tramping systematically about a hillside all the forenoon, and beating the long heather carefully though unavailingly, about midday I reached an extensive moss with a fairly large peathole upon it, the sight of which, after my wearisome tramp, afforded a welcome relief from the monotony of the wild moorland. I turned aside to see if any life was on it. The flowering trefoil (*Menyanthes trifoliata*) rendered gay one portion of the dark waters, but bird-life seemed to find no attraction there. I went cautiously along the edge, and eventually noticed a mallard duck rise suspiciously from the moss, but her young could not be found, though they were skulking somewhere near. The only other species noted at hand was the golden plover.

Having thus proved the peathole to be vacant, I renewed my search on the heather with no encouragement save from a single meadow pipit

A mallard's nest was soon found, from which the young had escaped, closely concealed amongst the heather, and during my halt at its side the duck passed again. Owl castings were as thickly scattered about as heretofore, and kept me in hope of final success. Walking through the heather I constantly disturbed red dragonflies, but for a long time no birds were roused. The day was surpassingly bright, and the strong sun that had already blistered my ears was now doing the same to my hands. Presently I found on the verge of a tract that had been burned, though actually amongst long heather, the deserted nest of a mallard with eight eggs. No doubt the heather burning had caused the forsaking. A yard or two from the mallard's nest and just within the burned area were the remains of an owl's nest that had probably been destroyed likewise; a little moss, perhaps naturally there, was all there was to mark a nest, and on this lay a casting and the pieces of the broken eggshells.

When one fears that the bird one is in search of sits so closely as to allow of one's nearly trampling upon her before she can be induced to rise, one is apt to allow the thought to grow strongly that the bird and nest have been passed. Crossing the same ground more than once, I especially noticed that though the time was rapidly passing, and although almost continuously on the tramp, I had covered but a short area in my eagerness to search it aright. The cry of a merlin helped to relieve the desolation for a moment, but dismal silence

again followed, and, unattended by any birds at all, I beat on. At length, however, the lark renewed its song and enlivened the waste, and at 1.35 p.m. a hen harrier—the first I had seen in Orkney—fluttered up in silence before me, and with easy flight crossed to the ridge and disappeared behind it. The nest was placed in an open depression amongst the heather, without any effort at concealment, and the sight of the five eggs at once atoned for the long wait and search that had preceded their discovery. At the locality chosen for nidification many blanched stems stood up amongst the heather and exposed peat was but a little way off. A bare spot had been selected on which a bulky nest of heather had been built sufficiently high to be beyond the effect of the damp when wet weather filled the underlying moss, and a dense mass of fine dry bent—between one and two inches in thickness—had been inserted as a lining. The nest measured across the inner diameter seven and five-eighths inches, and was two and a-half inches deep in the cup, and the heather around was adorned with downy plumes from the sitting bird. Shortly after resting by the nest I heard a curious cry, prolonged and somewhat resembling a kestrel's, though much shriller—"cheeki, cheeki, cheeki, cheeki"—which announced the harrier's approach. She passed closely over my head, and by her noise brought her mate on the scene. His was a quite different cry, somewhat like "hiky, hiky, hiky, hiky" continuously maintained. He came flying boldly in the line of my head, passing upwards before he came too near. They alighted on the crest of the surrounding knowe, and periodically flew towards me with chiding call; but at length, seeing my persistency in remaining, they resumed silence. The eggs were incubated, one of the clutch being addled.

After more than an hour's halt at the harrier's nest, I went towards another loch marked in my map; but, finding peat digging too prevalent an obstruction, terminated my outward journey, and turned homewards by hills lying further to the west, where excellent heather also occurred. Some time was spent in watching a twite, whose nest I suspected to be amongst the heather, and I then passed on over ground that increased in splendour until I reached an extensive bog, ridged with mounds on which heather, knee-deep, grew thickly and closely, with intervening depressions covered with long grass, and of a very treacherous nature. Here cattle were grazing, and boys were herding them to prevent their falling into the peatholes. I entered into conversation with one of these herd boys and learned that he knew "a ool's nest," but as it was out of his bounds he could not be induced to show it me lest the cattle should, meanwhile, come to grief. Barely had I parted with him before my attention

was arrested by a curious cry ahead, and there to my great delight was another pair of harriers quartering the valley, rising and falling as they went, the beautiful blue male with conspicuous black primaries going last. I followed their course with the closest attention till they both disappeared, and was so deeply interested in observing them, that I did not try to detail their actions. Further interruption occurred through a man who had crossed the moss to enquire if my search was for lost sheep, as he had found two; but I deftly turned the conversation from sheep to harriers, and as we stood speaking the male harrier came flying along the valley. Such a sight was nothing to the man, as it only raised bitter feelings in his breast against the bird. He drew my attention at the same time to a "moussiehawk" and its mate: they were a pair of merlins dashing across the valley. Disappointed in the object of his trip across the bog, he soon left me, and I wandered on through the heather and rushes, the latter of which were two and a-half feet in height. Again I caught sight of the male harrier rising and falling, attacking something on the ground; the object of his attack was hidden by a small intervening mound, but the bird himself was prominent enough as he rose in the air for each successive swoop. As he kept up this peculiar performance a lesser blackback appeared on the scene and began to mob him in turn every time he rose in the air, but the harrier paid no heed. I hurried forward to discover the cause of offence, and the harrier decamped.

The dreaded mist descended soon afterwards, and put an end to my opportunities for the time being, as all my attention henceforth was devoted to finding my way out of the moss. On the following day, however, I returned to the same neighbourhood and, after an hour's search, came on a nest of short-eared owls, from which the young had escaped: one addled egg had been left in the nest, and this was appropriated. I intended to give my attention solely to the owls, which were common here, but was so persistently attracted by the calling of harriers, that I could not neglect the latter species. Ever and anon the fighting cry, "meeyü meeyü," of the harrier would warn me of their approach, and I would halt to watch a pair passing along the hill-crest or quartering the valley. A harrier would quarter back and forward across a rush bed, giving two or three flaps of his huge wings, moving from side to side, then slightly hovering with wings faintly upturned, or sailing along on motionless pinions, and periodically settling on the ground only to rise again in a short time for another hunt. The male is a very conspicuous bird, of a beautiful blue, except his primary feathers, which are black. He is a noisy bird too, and when his premises are invaded he

keeps squealing in the air around the intruder, uttering a continuous "hiky hiky," and sometimes flying in a more definite manner for his disturber's head, no doubt according as the nest is more or less closely approached. On the ground the harrier stands with tail clear of the surface, his neck deeply depressed on his shoulders, and his back having a uniform slope. At one time two males attended me noisily, and on the departure of one of them the other remained constant, flying

above me, with his black primaries spread widely, or alighting not far off, and calling incessantly both on the ground and in the air. Later on in the day, at a very irregular strip of ground, a female harrier got up about fifty yards ahead of me, but as she did not return to encourage me in my search, she had probably not risen from her nest. This was the last harrier seen by me, as I left Orkney early on the following morning.

46, Cumberland Street, Edinburgh.

## MILLPORT MARINE BIOLOGICAL STATION.

AS a rule, annual reports of institutions or societies do not constitute very interesting reading, except to those immediately concerned. Notwithstanding the probable occurrence of references to the "success of the work carried on," and, it may be, numerous acknowledgments of financial aid, it is not infrequently the case that a vein of melancholy may be detected underneath all the fine phrases. When we finally come to the actual facts and figures of membership and donations, we often find that matters are really not quite so rosy as the optimistic framers would fain imagine; it must then be admitted that the pleasure to be derived from perusal may be seriously interfered with.

It is not so, however, with the annual report for 1897, of the Millport Marine Biological Station, now issued. It cannot be otherwise characterised than as eminently satisfactory throughout; and as also providing a most interesting narrative for our perusal. This report merits special notice from the fact that it is the first issued since the location of the station in permanent quarters at Keppel Pier on the Island of Cumbrae. This substantial and admirably situated building was opened nearly a year ago as the successor of the "Ark," beached at Millport about eleven or twelve years previously, by Dr. John Murray, of the "Challenger" Expedition; for the purpose of carrying on the work of a zoological laboratory. Many distinguished men took advantage of the facilities for study and research offered by this laboratory while located in the "Ark," and among them may be noticed the names of Professors Haeckel, Agassiz, Lankester and others, hailing from Germany, America, and places nearer home.

A few years ago a committee was formed for the purpose of securing a permanent station for the prosecution of zoological and kindred studies, with Mr. George McCrie as Chairman and the late Mr. Dugald Bell, F.G.S., as Secretary. Dr. Robertson's untiring zeal in this connection is also well known. The public were admitted at a nominal charge to the section set apart as a marine exhibi-

tion. In the course of time the facilities of the "Ark" were found to be taxed to the utmost to meet the demands of the students who were desirous of taking advantage of such aids to study and research as were afforded. The committee therefore began to raise funds for the erection of a building more in keeping with the dignity of their aims. These funds were liberally subscribed, a free site was generously granted by the Marquis of Bute, and the result is the handsome edifice familiar to all who sail through Fairlie Roads. The new station was formally opened by Dr. John Murray, assisted by a distinguished company, in May last, and since then the tables of the laboratory have been fully occupied by students prosecuting studies in various departments of biology and zoology. Among these were no less than eight lady medical students who took advantage of the laboratory.

Although it is too soon to expect that many original discoveries should be made connected with the marine fauna and flora of the area dredged in the vicinity, a beginning has been made in this direction. Mr. George Brebner, Lecturer on Botany in University College, Bristol, has been enabled to prove while at Millport that two brown seaweeds belonging to the Tilopteridaceae, which were formerly looked upon as separate genera, are in reality the same plant.

The Robertson Museum, in connection with the station, which is open to the public at a nominal charge, was visited by many persons during the season, the numbers reaching nearly two thousand in July and August. In cases round the walls are arranged the collection of fossil and contemporaneous shells, formed by the late Dr. Robertson; while his collection of seaweeds, beautifully mounted by Mrs. Robertson, are arranged in neat glazed frames on the walls. Dr. Murray, and Dr. Dohrn, of Naples, also contribute many interesting exhibits. The beautiful and life-like preparations of the latter naturalist are sure to attract the attention of the visitors.

During the summer Professor G. Bell Todd and

Mr. John Main, F.G.S., visited the museum on different occasions with the members of their respective science classes, much, no doubt, to their advantage. During what may be termed the "off" season at Millport, a number of preserved and living specimens were taken to Edinburgh, and exhibited before the Field Naturalists' and Microscopical Society. In August, numerous members of the Greenock Natural History Society visited the station, and were much interested in all they saw there.

In the list of office-bearers are to be found the names of many of the most active scientific workers in our midst; these include, according to the constitution, representatives of Glasgow University, Anderson's College, St. Mungo's College, Natural History and other learned societies of Glasgow; Paisley Natural History and Philosophical Societies, and the Greenock Natural History Society; Mr. David Robertson discharging the onerous duties of Acting Joint Secretary. From these details we may feel assured that the Biological Station at Millport is under most excellent and sympathetic management; and, as Lord Kelvin said in his letter read at the opening ceremony: "You have glorious traditions which make Millport for ever classic ground to the marine zoologist; and now that you have added the material support derived from a suitable laboratory, one cannot doubt that a bright career of useful scientific work is opening up before you, and that the name of the Millport Marine Biological Station will be found frequently associated in the future with researches on the fauna and flora of the British Seas."

G. W. NIVEN.

23, Newton Street, Greenock.

**FLOUNDERS.**—In a report printed in the "Journal of the Marine Biological Association" for April, 1898, by Dr. Georg Duncker, on his investigations of certain fishes at the Plymouth Laboratory, some notes on the variation of flounders (*Pleuronectes flesus* Linn.), are given. It appears that the Plymouth flounders form a distinct race from those of the Baltic and south-eastern parts of the North Sea. Those from the channel off Devonshire are similar to the form *Pleuronectes italicus*, of Günther, found in the Mediterranean. They differ from those of the north in having a high number of fin-rays in the dorsal and the anal fin. The averages are dorsal 61-62, anal 43-44 rays. Further distinction is in having an almost entirely smooth squamation on the blind side. These results were attained after an examination of 1,120 individuals, of which 602 were males and 518 were females. Of the males 6.6 per cent. had the eyes on the left side of the head, but in only 3.8 per cent. of the females were they so situated. The males proved more variable than the females in the number of the fin-rays. In both pectoral fins, a slight increase in the number of rays appear to occur with the total length caused by age. Will some of our readers examine the flounders on other portions of the British coast, and let us have their experiences?

## HELIX NEMORALIS IN IRELAND.

BY JOHN T. CARRINGTON.

I AM indebted to Mr. R. Welch, of Belfast, for kindly sending me a boxful of *Tachea nemoralis*, gathered by a friend who is a geologist and not a malacologist. The specimens numbered 226, and were nearly all dead shells found in "pockets" in the sand, as described by Mr. Welch in the "Irish Naturalist" for March, 1898. The locality was the Sand Dunes of Dundrum Bay, at Ballykinlar, Co. Down. They were collected "just as they came, without any selection." Consequently, though the specimens were in faded and often broken condition, we get a fair average of the forms locally represented. The following is the result of an examination for colour variation, abnormal form and band formulæ.

The colour variation included only two of the usual forms, namely, 116 *rubella* and 110 *libellula*. The only deviation in form was var. *conica*, of which there were three examples.

1 band	00300	..	..	13 specimens
4 bands	10345	..	..	3 "
5 "	12345	..	..	138 "
5 bands in 1 =	(12345)	..	..	6 "
5 "	2 = (123)	(45)	..	18 "
5 "	3 = 1	(23) (45)	..	1 "
5 "	3 = (123)	45	..	9 "
5 "	3 = 12	(123)	..	1 "
5 "	4 = (12)	345	..	4 "
5 "	4 = 1	(23) 45	..	31 "
5 "	4 = 123	(45)	..	2 "

In comparison with similar numbers gathered in South and East of England localities, the above batch shows a small range of variation, and is remarkable for the absence of some band formulæ beyond the ordinary five bands commonly represented elsewhere. The following is an analysis of the above forms, comparing with the examples occurring on Lincolnshire sandhills, Middlesex, Herts, Kent, Surrey, Sussex and some other southern English counties worked by me:—

One band, 00300, is one of the commonest forms in England, the proportion of thirteen to 226 being smaller than is usual.

Four bands, 10345, is of frequent occurrence in many localities. It will be noted how few are the other absent bands in the Ballykinlar specimens.

Five bands. The typical formula of five bands is by far the most common, 138 specimens out of the total of 226, or more than half. At some localities searched by me in southern England the five-banded form appears among the band formulæ least frequently found.

Five bands in one = (12345). The proportion of six in 226 is about a usual proportion in many localities, though high for others.



Five bands in two = (123)(45). Eighteen specimens out of the total is liberal allowance.

Five bands in three = 1(23)(45), is usually an uncommon form, as in this case.

Five bands in three = (123)45, is, in my experience, a rare form. I have only found it once, and that in North Kent. I was surprised to find so many as nine examples in this gathering. Unfortunately, they are, with a few exceptions, in very bad condition.

Five bands in three = 12(345), is also an uncommon form.

One of our commonest combinations of five in three is, it will be observed, absent from the Irish batch, viz., (12)3(45).

Five bands in four = (12)345, is much rarer than usual in such a gathering.

Five bands in four = 1(23)45, is generally a common form, though rather liberally represented in this batch.

Five bands in four = 123(45), is not well represented by four examples.

Many of the above specimens from Ballykinlar are much thinner than usual, though others are quite up to the ordinary weight. The average of size is about normal.

## NOMENCLATURE OF SHELLS.

ENGAGED in compiling a list of Upper Tertiary fossils, I am puzzled as to the generic synonymy of some of the land shells. Will anyone better versed in the subject kindly enlighten me? I want to know the correct generic or sub-generic names for the following Helices, all British, recent or pleistocene. I find Mrs. McKenny Hughes (Geol. Mag., 1888: Pleist. Gravels, p. 193), the Conch. Soc. List of Land and Freshwater Mollusca, 1892, and Messrs. Woodward and Kennard (Essex Nat., v. x. 1897: Post-Plioc. Non-Marine Moll. Essex), at variance in this matter.

SPECIES.	GENUS. file Mrs. McK. Hughes.	GENUS. In Conch. Soc.	GENUS. In Woodw. & Kenn.
<i>obsoleta</i>	<i>Anchytoma</i>	<i>Gonostoma</i>	<i>Helicodonta</i>
<i>fruticum</i>	<i>Fruticicola</i>	—	<i>Eulota</i>
<i>erectorum</i>	<i>Xerophila</i>	<i>Xerophila</i>	<i>Helicella</i>
<i>hispida</i>	<i>Fruticicola</i>	<i>Fruticicola</i>	<i>Hygromia</i>
<i>arbutorum</i>	—	<i>Aranta</i>	<i>Helicogona</i>
<i>rotundata</i>	<i>Patula</i>	<i>Patula</i>	<i>Pyramidula</i>
<i>pinna</i>	—	<i>Xerophila</i>	<i>Helix</i>
<i>aspera</i>	—	<i>Pomatia</i>	<i>Helix</i>
<i>pygmaea</i>	<i>Patula</i>	<i>Punctum</i>	<i>Punctum</i>

and so on

Again, on what grounds is the non-umbilicated long and tapering *Bulimus acutus* (*Helix barbara*) grouped with the flat and broadly open *erectorum*?

ALFRED BELL.

191 Street, London, W.C.

## BOTANICAL COMPETITION.

THE Editor of SCIENCE-GOSSIP repeats his offer of prizes for competition on similar conditions to those of last season (SCIENCE-GOSSIP, ante pp. 46 and 198) which were as follows.

THE FIRST PRIZE is to be one or more books on any subject, at the selection of the winner, up to the published value of £2 10s.

THE SECOND PRIZE will be of a like character, valued at £1 10s.

- (1) That there shall be at least ten competitors.
- (2) That the names and addresses of competitors shall be sent in before October 1st, 1897.
- (3) That the competition shall apply to photographs of uncommon, local, or rare plants.
- (4) That three pictures be taken of the plants while growing: (a) Best showing the habit of growth when flowering, fruit, or otherwise; (b) of the growing plant and its immediate surroundings; (c) of the near landscape to show the character of the plant's station.
- (5) That any sized picture up to, though not exceeding, half plate will be acceptable for competition; quarter plate size will be preferred, but will not influence the prize.
- (6) That the Editor have the right to reproduce any of the competing pictures in SCIENCE-GOSSIP or elsewhere. The negatives to be the property of the competitor.
- (7) The locality of the habitat or station of the plant sent for competition must be given; but not necessarily for publication, if good reason is given.
- (8) That one or more dried specimens from the same locality must accompany the photographs of the plants for confirmation of identity.
- (9) That the competitor supply, if required by the editor on reproducing in print any of the competing pictures, notes on the habits, growth, flowering, range of local distribution, and other facts which may be of interest to botanists and general readers.
- (10) That any kind of plants are available for the competition, and may include ferns, mosses, fungi, marine algæ, etc.
- (11) That all the pictures for the competition are to be delivered, in duplicate and unmounted, at the office of SCIENCE-GOSSIP not later than October 25th, 1898.

The judging of the pictures will be by the Editor of SCIENCE-GOSSIP, whose decision will be final. He will, however, invite the co-operation of our botanist referee and two leading photographers, whose names will be duly announced.

The chief points to be considered will be (a) the variety of the species photographed; (b) the grasp of detail, such as the natural position, the flowering parts, and other surrounding, in case any appear; (c) the excellence of the photography.

The name and address of the competitor must be neatly written in lead pencil on the back of each competing picture. One competitor may send three or less subjects for competition, each being available for competition on its own merits.

The awards of prizes will be announced as soon as practicable after the 1st of November next, probably in the December number of SCIENCE-GOSSIP. It is intended to reproduce the prize pictures in SCIENCE-GOSSIP. All the competing photographs will be circulated for examination among the competitors during the winter months.

JOHN T. CARRINGTON.



MESSRS. DAWBARN AND WARD, LIMITED, of Farringdon Avenue, London, have been appointed English agents for the new "Journal of Applied Microscopy," issued from Rochester, New York.

M. JULES MARCO, a French geologist who spent most of his life in geological explorations, especially in America, died on April 18th at Cambridge, Mass.; he was in his 74th year. Several works on geology stand to his credit.

THE series of articles in SCIENCE-GOSSIP on "The Armature of Helicoid Landshells," by Mr. G. K. Gude, have been temporarily interrupted in consequence of awaiting material from America. This having arrived, the author will continue the work in next month's issue.

THE LATE SOLAR ECLIPSE.—The Rev. J. M. Bacon appears to have been doubly unfortunate on his late Indian solar eclipse expedition, for not only did he lose his gold watch, but the film with the cinematographic photograph of the eclipse was found to be missing when his package arrived home.

THE older Naturalists' Union of Lincolnshire rather resents the formation of the new Lincolnshire Science Society, which has much in common with the Union for its objects. A healthy competition will doubtless be to the advantage of science in the county, and for the prospects of the proposed Lincoln Museum.

AMONG the catalogues received this month is one of books on Arthropoda from the libraries of Herr Staatsrath, Professor Japetus Steenstrup and Dr. Wallengren, for sale by Max Weg, 1, Leplaystrass, Leipzig. Many scarce and interesting works are included in its fifty-four closely-printed pages of over 2,000 titles.

AMONG recent deaths is that of Rudolf Leuckart, Professor of Zoology at Giessen and Leipzig. His more important work was the study of animal parasitic worms. He it was who, as well as our countryman, A. P. Thomas, worked out the life-history of the liver-fluke. He was born in 1822, and always attained the highest respect among the leading teachers of zoology.

PROFESSOR KIRK, F.L.S., author of "Forest Flora of New Zealand," and an officer in the Department of Woods and Forests, under the Government of that Colony, will be much missed by the supporters of Natural Science at the antipodes. He was an authority on the botany and timber trees of Australasia, which he had studied during his many years of residence in New Zealand. His monographs are well-known to English students, and are always regarded as trustworthy and authoritative. For some time, Professor Kirk held the position of Conservator of State Forests of New Zealand, and he was an active member of the New Zealand Institute. Professor Kirk was engaged up till his death on an extensive work on the botany of Australasia.

ARRANGEMENTS are in progress for an acetylene gas apparatus exhibition at the Imperial Institute, London. The Secretary will be Sir Henry Truman Wood.

THE Norfolk County Council have obtained the usual Order to prohibit the destroying of eggs of any species of wild birds for one year, from May 1st, within the area of the Norfolk Broads.

FROM the general report on mines and quarries for 1897, we find the output of coal in that year in Britain was 202,119,196 tons, ironstone was taken to the extent of 7,793,163 tons, and oil shale 2,223,757 tons.

THE Rev. E. F. Linton is engaged upon a new "British Flora." He is taking the "London Catalogue" as his basis. We hope the author will give us some synonyms, for many who know plants by sight cannot recognize some of them by their London Catalogue names.

THE American Association for the Advancement of Science will hold its Jubilee Meeting at Boston, from August 22nd to the 27th. An important circular setting out the proposed arrangements for the meeting has been issued. These promise to be exceptionally successful.

PROFESSOR W. F. R. WELDON, F.R.S., is to lecture on "Butterflies" on May 10th; and on June 7th, Professor Marshall Ward, F.R.S., on "A Piece of Wood," at the Whitechapel Free Public Library and Museum. The admission is free by ticket on previous application at either of those institutions.

THE United States Senate recently passed a Bill for the protection of song birds, also prohibiting the importation or transportation in any parts of the States or District of Columbia, of birds, feathers or parts of birds for ornamental purposes. Cannot a Bill be introduced into the British Parliament dealing in a like manner with the latter subject?

WE would draw the attention of our botanical readers to the renewal of last season's photographic competition. Full particulars will be found on p. 353 in this number. Dr. Porter's translation of the Bonn Text Book of Botany formed the consolation prize mentioned on *ante* p. 198, as awarded to Mr. W. P. Winter, of Cheltenham, to whom it has been duly forwarded.

AN important paper was read on March 31st, at the Imperial Institute, by Mr. H. Luttman-Johnson, I.C.S., on "The Earthquake of Assam." He described at length some of the remarkable results of the violent vibrations that lasted about three minutes. These extended in backward and forward movements of about seven inches. Earth tremors continued for three days afterwards. The area affected was about 1,500 miles by 1,000 miles wide.

A CONFERENCE on meteorology, held in Paris in 1896, appointed a committee of aerostatic experiment, under the presidency of Dr. Hergesell, of the Weather Office of Alsace-Lorraine. This committee has attained some remarkable results by simultaneous balloon ascents in Paris, St. Petersburg and Berlin. Some of the altitudes exceeded sixteen kilometres. A special meeting has been held at Strasburg to discuss these results, about forty persons being present from France, Austria, Germany, Russia and America. The object of these experiments is to obtain accuracy in forecasting.

## BOOKS TO READ

NOTICES BY JOHN T. CARRINGTON.

*A Text Book of Botany.* By Dr. E. STRASBURGER, Dr. FRITZ NOLL, Dr. H. SCHENCK, and Dr. A. F. W. SCHIMPER. Translated by H. C. PORTER, Ph.D. 642 pp. royal 8vo, with 594 coloured and plain illustrations. (London and New York: Macmillan and Co., 1898.) 18s. net.

This excellent text book, so well known to German students of botany at the University of Bonn, where its authors are members of the staff of Professors, has been carefully translated from German into English by Dr. Porter, Instructor of Botany in the University of Pennsylvania. The publishers have also secured the assistance, in revising the proofs, of Mr. A. C. Seward, M.A., University Lecturer on Botany at Cambridge. We have, therefore, in this, one of the most modern and carefully prepared works that has recently been submitted to botanists. The introduction is in itself a concise treatise on the evolution of plants, and one to be read carefully by all who would understand vegetable life. It commences at the beginning of plant life, thus: "It is customary to divide all living organisms into two great kingdoms—animal and vegetable. A sharp boundary line between animal and vegetable life, can, however, be drawn only in the case of the more highly developed organisms, while in those of more simple organisms, all distinctions disappear, and it becomes difficult to define the exact limits of botany and zoology." The simplest organisms which now exist are in all probability similar to those which formed the starting-point in the phylogenetic development of animal and vegetable life. The main work is divided into two parts of two sections each. These are Part I, General Botany. Section I, Morphology. This contains the external morphology, including de-

velopment of form, relations of symmetry, branch systems, the shoot, the root and ontogeny of plants. Internal morphology deals with the cell-tissues, phylogeny and ontogeny of the internal structure, also structural deviations. Section II is Physiology, including vital attributes of plants, stability of the plant body, nutrition, respiration, growth, movement and reproduction. Part 2 is entitled Special Botany: Section I, devoted to Cryptogams, and Section II, to Phanerogamia. Then follow notes of Official and Poisonous Plants, the latter with coloured drawings in the text. The whole of the illustrations are carefully selected and well executed. They are drawn from familiar

European plants, most being in the British flora, or cultivated species well known in gardens. As nearly all the poisonous kinds are in colours the young botanist has his attention drawn to them early; though he must not imagine those here represented are all, as that is not by any means the case. In the part of this work occupied by Special Botany, every class and most of the families are illustrated by examples, and the figures are excellently drawn. We show the walnut as an example, by permission of the publishers. This handsome and useful work is sure to be largely in demand for both library and scholastic purposes.

*Memory and its Cultivation.* By F. W. EDRIDGE-GREEN, M.D., F.R.G.S. 311 pp. 8vo, with frontispiece. (London: Kegan Paul, Trench, Trübner and Co., Limited, 1897.) 5s.

This is one of the International Scientific Series published by the above firm, and though only just to hand, appears to have been issued some time ago.

As probably most of our readers have seen the work, it is hardly necessary for us to say much about it. The frontispiece is a rather coarse diagram indicating the relation of the centres of memory to the other parts of the brain. The object of the work is to explain the scientific cultivation of memory, especially with the view of saving time, and so enabling one to get more work out of one's waking hours. If carefully studied, many persons, on following the suggestions, will gain much by educating their powers of memory. The arrangement of the book is good, and carries the interest of the reader well to the end.

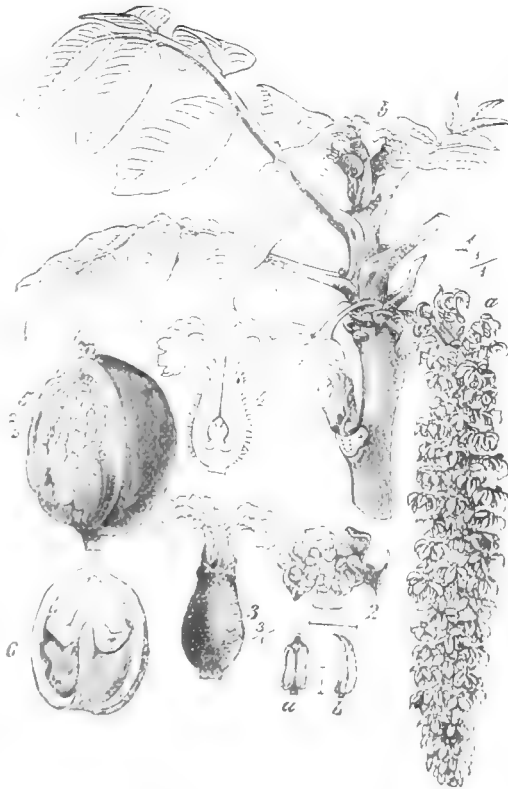

THE WALNUT (*Juglans regia*).

- 1.—Branch with male (a) and female (b) inflorescences.
- 2.—A group of male flowers: (a) stamen seen from the inner side, (b) the same seen from the outer side.
- 3.—A female flower.
- 4.—The same in longitudinal section.
- 5.—Fruit with pericarp partly removed.
- 6.—The same in longitudinal section.

*Elementary Chemistry.* By T. A. CHEETHAM, F.C.S. 128 pp. 8vo, with 24 illustrations. (London: Blackie and Son, Limited, 1898.) 1s. 6d.

As a first year's course of practical and theoretical chemistry, this little work sets forth a useful plan of study and experiments. The arrangement of the laboratory work and side references to paragraphs throughout the book is good; the latter, being in conspicuous type, readily enables the scholar to find what is required with the aid of the contents table at the commencement. There is also a comparative diagram of French and English measures.

*British Game Birds and Wild Fowl.* By BEVERLEY R. MORRIS, M.D., revised by W. B. TEGETMEIR, F.Z.S. Parts xi. and xii., super royal 8vo, with coloured plates. (London: John C. Nimmo, 1897-8.) 2s. 6d. per part.

Part 12 completes this ornamental book. It is a pity the opportunity afforded by the issue of a new edition has not been secured to thoroughly bring the work up to the condition of present common knowledge. The revision in this edition is sadly incomplete, and leaves the work little changed.

*British Orthoptera.* By MALCOLM BURR, F.Z.S., F.E.S. 70 pp. 8vo, with 6 plates. (Huddersfield: Economic Museum, 1897.) 3s. 6d.

As a handbook to an order of insects hitherto but little studied in Britain, the work before us will prove most useful. As it becomes better known, this manual cannot fail to induce many entomologists to take up the study of our native earwigs, cockroaches, grasshoppers and crickets. Unfortunately there are some errors which should have been corrected by the printer in the proof slips, before going to press. Mr. Burr has, however, issued a note correcting them, which those who possess the work would do well to obtain. Otherwise, with regard to the letterpress, the author is to be congratulated upon his efforts. We wish we could say as much for the plates, which are unsatisfactory in drawing in many instances; and the colouring is among the worst we have seen. In the copy before us on some of the plates little or no attempt has been made to keep the "register," leaving part of the subjects uncoloured while the pigment is smeared away from the drawing in a most unpleasant manner. Neither is there any serious attempt to follow the living colours of the more delicate species. In fact, we cannot forbear sympathising with the author in what must be a great disappointment. We hope the increasing interest which has arisen in the British Orthoptera will soon exhaust this edition and enable Mr. Burr to issue another, where these defects will be remedied. Even with them this is a most useful work, especially as there is not any other recent one available.

*The Story of Photography.* By ALFRED T. STORY. 181 pp. small 8vo, with 38 illustrations. (London: George Newnes, Limited, 1898.) 1s.

This is another of the "Library of Useful Stories," which are popularizing the subjects treated, and at the same time educating the readers in many forgotten points of history well worthy of remembrance. The author of this little work has treated his subject historically, commencing with the earliest uncertain steps that have led to its present excellence as an art. Few thinking people will imagine that the height of this success has been attained, for hardly a week passes without the record of some improvement. Mr. Story has used considerable judgment in the arrangement of his literary material, and, with the aid of the diagrams and other illustrations, presents his story in a very readable manner.

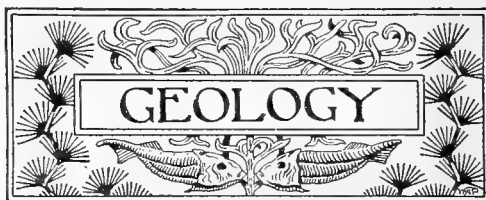

CONDUCTED BY EDWARD A. MARTIN, F.G.S.

*To whom all Notes, Articles and material relating to Geology, and intended for SCIENCE-GOSSIP, are, in the first instance, to be addressed at 69, Bensham Manor Road, Thornton Heath.*

PEBBLY AND OTHER GRAVELS IN SOUTHERN ENGLAND.—An important paper was read by Mr. A. E. Salter, B.Sc., F.G.S., at the meeting of the Geologists' Association, on March 3rd, at University College, in which, after a general account of gravels, and the valley excavation they indicate, the author described in detail those of the Thames Basin. These he arranged in three main divisions: (1) High Level or Early Drift, indicating, on the south side, streams from the Wealden area, flowing north in the Darent area and north-west in the Bagshot district; (2) Lower Plateau or Glacial Gravels, having a much closer relation to the present valleys than the preceding; (3) River Gravels, containing Palaeolithic tools and Pleistocene mammalia in their upper terraces. The application of the knowledge gained in the Thames area to the gravels of Hants, Dorset, Devon and Cornwall then followed. The author went on to show that in the old Frome Valley, the lower part of which is now destroyed by the sea, a similar series at corresponding levels is found, and that further west High Level Drift occurs on the Blackdown Hills, near Weymouth, and also on the Haldon Hills, in Devon, while Lower Plateau Drift covers the hills near Axminster and Sidmouth, and is also found in the Teign Valley, at Woolborough Hill, etc. The River Drifts are likewise represented. West Devon and Cornwall tell a similar story. The author thinks that Dartmoor was the source of the rivers depositing the High Level Gravels of Dorset and Devon in Pliocene times, and that probably a stream flowed across Central England in a north-east direction and deposited the so-called Westleton shingle, the constituents of which are in many cases derived from the West of England. The paper was illustrated by numerous specimens and diagrams.

OPAL PSEUDOMORPH.—A magnificent specimen of opal was exhibited at the meeting of the Geological Society on April 6th, by Professor H. G. Seeley, which took the form of a humerus of a plesiosaurian. This pseudomorph was almost entirely opalised, and was translucent, with the exception of one end which was composed of phosphate of lime. The specimen came from New South Wales, and it is hoped that, success awaiting the negotiations with the Opal Company, the present owners, it may find a resting-place in the national collection. It is said to be a unique specimen.

"EOLITHIC" IMPLEMENTS.—At the same meeting a paper was read by Mr. W. Cunnington, F.G.S., on "Some Palaeolithic Implements from the Plateau Gravels, and the Evidence concerning 'Eolithic' Man." Although at first inclined to believe that the chipping on the "eoliths" of the plateau gravels of Kent was the work of man,

Mr. Cunnington was led to recant this opinion by the detailed study of specimens lent or given to him by Mr. Benjamin Harrison. His reasons were mainly based on the facts that the chipping is of different dates even upon the same specimen, and that it was produced by natural causes after the specimens were embedded in the gravel. One implement seemed to prove that Palæolithic man lived on the Kentish Plateau before or during the deposit of the plateau gravels, and that the "Eolithic" chipping is not the work of man. In the discussion that followed the paper, the greatest differences of opinion manifested themselves, not only as to whether "eoliths" were the work of man at all, but also amongst those who admitted their human workmanship, as to whether the "Eolithic" working was earlier or subsequent to the Palæolithic chipping. As illustrating the alleged "Eolithic" working, one specimen which was derived from the plateau gravels was selected as presenting the following stages. First it appeared to have been fashioned by man into a Palæolithic implement, then it was abraded, broken and chipped along one edge in the same fashion as the alleged "Eolithic" working, finally it was stained, marked with glacial striae, and covered with a thin layer of white silica. Mr. Cunnington has, we venture to think, done well in arresting the rage for attributing so much of what may, after all, be the work of natural fracturing to the hand of man.

**THE WORK OF WORMS.** During the above discussion, Mr. A. E. Salter, F.G.S., reminded those present that as Darwin found a layer of chalk in the field became gradually hidden to view through being covered up by worm-casts, so ancient flint implements when cast away would tend similarly to become hidden beneath the soil.

**SUPPLY OF WATER FROM THE CHALK.** The boring that was put down at Streatham Common by the Southwark and Vauxhall Water Company eight years ago, which it will be remembered demonstrated the fact that the Lower Greensand had thinned out on the south, is yielding regularly two and a-quarter millions of gallons of water a day. The bore-hole extends below Jurassic rocks, but it is known that about a million gallons of this water supply comes direct from the chalk alone. It is hoped that with increased pumping-power, a supply exceeding three millions will be obtained. The level of the water has been lowered from the normal of fifty feet to nearly one hundred feet below ground. The chalk is 24½ feet from the surface.

**"CHALLENGER" NOTES.**—Ocean deposits may be divided into (i) shore-deposits, accumulating between tide-marks; (ii) infra-littoral and deeper water deposits, accumulating between low-water and depths of 2,000 fathoms. These extend to 200 miles, or even more, from land. The approach of the "Challenger" to land could always be foretold when 150 to 200 miles off, by the blue and green muds there accumulating. The green muds, from 100 to 700 fathoms, contained lamellibranchs, pteropods, and infra-littoral foraminifera. Below 1,500 to 1,700 fathoms there were seldom any pteropods, whilst at 3,000 fathoms hardly a foraminifer or calcareous organism remained. (iii) Abyssal or pelagic deposits. These are found at depths of more than 2,000 fathoms, and consist of red and grey clays, covering about fifty million square miles of ocean floor. The fragments of diatoms accumulate at depths from 1,000 to 1,975 fathoms, as a pale straw coloured deposit. Murray

and Irvine estimate that diatomaceous deposits cover 10,420,600 square miles of sea-bottom. Diatoms occur both in fresh and salt water, and in surface waters, as well as at the bottoms of oceans.

**YORKSHIRE CARBONIFEROUS FLORA.**—The Fossil Flora Committee of the Yorkshire Naturalists' Union has just issued its sixth report, being the report for 1896. It deals principally with the species, thirty-nine in number, which were obtained from a new railway cutting at Brightside, near Sheffield. The rocks here exhibited were of a horizon of which there are few records. Mr. Hemingway determined the beds as being the "rock below the Haigh Moor Coal," known locally as the Brightside rock. Nine species not known previously from Yorkshire, are recorded by Mr. R. Kidston, F.R.S.E., F.G.S., from this cutting, of which seven are thought to be new to Britain. The nine new country records are: *Sphenopteris adiantoides* L. and H., *Lonchopteris eschweiliana* Andræ, *Lepidodendron feachi* Kidston, *Sigillaria semipulvinata* Kidston, *S. micaudi* Zeiller, *S. daveuxii* Brongt, *S. feistmanteli* Geinitz, *S. sol* Kidston, *Carpolithus ellipticus* Sternb.

**LONDON GEOLOGICAL FIELD CLASS.**—Professor Seeley, F.R.S., began the summer course of lecture-excursions with the London Geological Field Class on Saturday, the 23rd April. The subject of the series is "The Physical Geography and Geology of the Thames and its Tributaries." This is the thirteenth annual course. Mr. R. H. Bentley, 43, Gloucester Road, South Hornsey, N., is the Honorary Secretary of the class, which gives a systematic course of teaching in the open country. The localities and further dates of the excursions will be found in Notices of Societies.

**SHALE OIL.**—There appears to be in Indiana an inexhaustible supply of Genesee shales of Devonian age rich in bitumen, from which it will be possible to extract mineral oil. Mr. H. Duden found that at New Albany eight and a-half pounds of the shale, when analysed, yielded by distillation forty-five gallons of gas, possessing a twenty-two candle-power. Scotland yields annually sixty million gallons of oil from shale; so that when the approaching extinction of our supplies of coal at home causes coal-gas to become an expensive luxury, there will be a never-failing supply of illuminating oil in these bituminous shales.

**A SUBMARINE TRIASSIC OUTLIER.**—The existence of a Triassic outlier in the sea, having its centre about ten miles south-east of the Lizard Head, was shown in an interesting manner some years since by Mr. R. N. Worth, F.G.S. Its occurrence there had been suggested earlier, but by means of numerous specimens brought up by fishermen's "long lines," whose positions had been accurately determined beforehand, the outlier was placed beyond all doubt. The evidence showed that the upper surfaces of the pieces of Triassic sandstone were bored by *Pholades* or covered with marine organisms, whilst their under-surfaces were more or less free from them, the fragments having been apparently torn from the reefs *in situ*. The affinities of the series of pieces dredged up were with the Keuper of Devon, particularly with the rocks in the vicinity of Sidmouth. The discovery enabled geologists to carry Triassic rocks some fifty miles farther to the south-west.

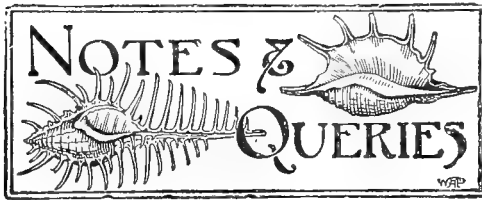

**GREAT SKUA IN SUSSEX.**—We hear from Messrs. Pratt and Son, taxidermists, of Brighton, that a fine example of the great skua (*Stercorarius catarrhactes*) was shot last winter near Havant. It is the only one this firm has seen in the flesh since 1880, when they then also had a Sussex bird.

**AN OBJECT IN FLINT.**—Some years ago, my friend, Dr. Gooch, of Windsor, was examining some fragments of flint at Diss, in Norfolk, for *Xanthidia*, etc., and he came unexpectedly upon an object, a photograph of which I enclose, which was quite new to him. He has submitted it to many of the savants of the day, but they have been puzzled with it and cannot say what it is. I asked the Doctor to let me try to photograph this, as it seems, unique object, and after many attempts got a fairly good photograph of it. I made a rough measurement and found it to be about  $\frac{1}{1000}$  of an inch in length. It being embedded in flint and not quite level, it is difficult to get every part in focus. However, I hope I have got the general appearance of the object sufficiently well to give your readers an idea of it. The Doctor would be greatly pleased if any of your readers could solve the mystery of "What is it?"—(Captain) Edward Barnes, Edgeworth House, Clewer, Windsor.

**DESTRUCTION OF BIRD-LIFE IN TASMANIA.**—The terrible bush fires which have been raging in many parts of Australia and Tasmania have caused great mortality among the fauna, especially the birds. It was the breeding time of many species. When the fire was raging through the thick undergrowth, the birds, instead of flying from the flames to a place of safety, would just flutter out a little way and then go back and become overpowered by the flames and smoke. This

applies more especially to the smaller birds, the larger ones generally escaped. In some districts in Tasmania where birds used to swarm unmolested round the farms, there is not one to be seen. Naturally the fires have caused a great scarcity of food for the birds; so they are forced to come into the towns in search of it. Consequently parrots and paraquets have done a great deal of damage to orchards, for they are nearly starving, being little more than feathers and bones.—F. M. Littler, Launceston, Tasmania.

**SPRING ARRIVALS.**—On April 6th we saw three swallows here, and next day many more. On the 8th of the same month we heard the chiff-chaff. On the 7th I saw a male orange-tip butterfly (*Euchloë cardamines*) flying in the garden, and another on the following day.

We have also seen *Pieris rapae*. I think the date of the appearance of both swallows and the "orange-tips" rather early, especially after the severe and wintry weather at the end of March.—T. H. Mead-Briggs, Rock House, Lynnmouth, North Devon.

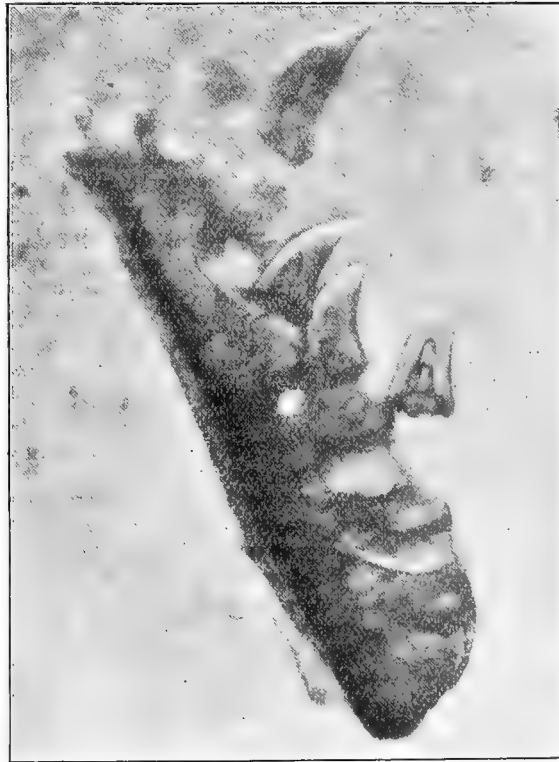

UNKNOWN OBJECT IN FLINT.

**CLAYTONIA PER-FOLIATA** Don.—This curious little plant, originally a native of North-West America, but rapidly becoming naturalized as a garden outcast in this country, was obtained in flower during an excursion of the Lambeth Field Club, on April 11th, to Cobham. It occurred close to a bush in the neighbourhood of a farmyard. The large connate, leafy bracts, with the little group of flowers nestling in the centre, the inner still in bud, the outer with their fine white petals

expanded, attracted our attention. The whole plant is tender and succulent, and, it is said, may be eaten like spinach. The leaf stalks are pale and glabrous, arising in a bunch from the ground in a manner suggestive of the caespitose clusters of the *Hypholomata* among the fungi, and terminate each in a broad spatulate leaf. The usual period of flowering is from May to July.—F. P. Perks, 41, St. Martin's Lane, Charing Cross, W.C.

**GREAT AUK EGG.**—A specimen, purchased for £60 by the late Lord Garvagh, but thought to have been destroyed in 1871, has been discovered in an attic with some other objects placed there after his death.



CONDUCTED BY FRANK C. DENNETT.

		Rises.		Sets.		Position at Noon.	
		h. m.	h. m.	h. m.	h. m.	R.A.	Dec.
		May.	May.	May.	May.	h. m.	Dec.
Sun	2	4:31 a.m.	7:22 p.m.	2:30	15° 28' N.		
	12	4:14	7:38	3:17	18° 13'		
	22	4:1	7:52	3:57	20° 27'		
		Rises.		Sets.		Age at Noon.	
		h. m.	h. m.	h. m.	d. h. m.		
Moon	2	2:59 p.m.	8:59 p.m.	2:30 a.m.	11 13 39		
	12	5:4 a.m.	5:49 a.m.	10:35	21 13 39		
	22	4:47	1:31 p.m.	10:12 p.m.	1 23 2		
		Souths.		Semi		Position at Noon.	
		h. m.	Diameter.	R.A.	Dec.		
		May.	h. m.	h. m.	h. m.	h. m.	Dec.
Mercury	2	11:50 a.m.	6° 0	2:31	15° 15' N.		
	12	10:56	5° 6	2:17	11° 15'		
	22	10:27	4° 6	2:27	10° 49'		
Venus	2	1:14 p.m.	5° 3	3:55	20° 42' N.		
	12	1:26	5° 4	4:47	23° 9'		
	22	1:29	5° 6	5:40	24° 30'		
Mars	2	9:19 a.m.	2° 4	0:40	3° 3' N.		
Jupiter	2	9:24 p.m.	19° 6	12:7	0° 54' N.		
	12	8:42	19° 1	12:5	1° 6'		
	22	8:2	18° 6	12:4	1° 11'		
Saturn	2	1:17 a.m.	8° 5	16:36	20° 6' S.		
Uranus	2	0:40	1° 9	15:59	20° 24' S.		
Neptune	2	1:56 p.m.	1° 3	5:22	21° 52' N.		

MOON'S PHASES.

Full	May 6	6:1 a.m.	3rd Qr.	May 12	9:36 p.m.
New	20	0:56 p.m.	1st Qr.	28	5:14 "

In perigee May 7th, at 9 p.m., distant 224,700 miles; and in apogee on 23rd, at 9 a.m., distant 252,300 miles.

CONJUNCTIONS OF PLANETS WITH THE MOON:

May	3	Jupiter*	9 a.m.	planet 6° 58' N.
	7	Saturn	12 p.m.	5° 7' N.
	17	Mars*	1 a.m.	6° 48' S.
	17	Mercury*	9 p.m.	8° 33' S.
	22	Venus†	6 p.m.	0° 51' S.
		Jupiter†	5 p.m.	7° 1' N.

\* Below English horizon. † Daylight.

OCCULTATIONS AND NEAR APPROACH:

May	Star.	Magni.	Dis.	Angle	Re-	Angle
		appears.	appears.	from	from	from
		h. m.	h. m.	Vertex.	h. m.	Vertex.
22	Venus	...	6:54 p.m.	115°	7:32 p.m.	184
27	♄ Leonis	5	11:37 "	346°	Near approach.	
29	♄ "	5 1/2	10:17 "	116°	11:16 p.m.	235

THE SUN still continues at intervals to exhibit considerable disturbances upon his surface

MERCURY is in inferior conjunction with the sun at 11 p.m. on 1st, and then becomes a morning star for the rest of the month, reaching its greatest elongation west (24° 31') at 5 p.m. on 28th, on which date he rises at 3 1/3 a.m., only forty-one minutes earlier than the sun

VENUS is an evening star all the month, setting an hour and three-quarters after the sun at the commencement and two and a-quarter hours at the end of the month, situated in Taurus until 24th, then in Gemini, in the north-western sky. The occultation on 21st should be observed

MARS is a morning star, rising little more than an hour and a half before the sun at the end of the

VESTA is in opposition on May 6th, so is at its best for observation, though it is in a very unfavourable part of the sky; its R.A., on April 25th, was 15h. 17m. and its S. Dec. 6° 20'; on May 25th it is in R.A. 14h. 49m., S. Dec. 5° 42', the retrograde path passing through a barren part of Libra.

JUPITER is still favourably placed for observation, pursuing a retrograde path near the 4th-magnitude star η Virginis.

SATURN comes into opposition at 10 a.m. on 30th, but its great south declination does not favour very successful observation; its ring is still beautifully open. On 20th its major and minor axes are respectively 42" 76 and 18" 69, whilst the planet's diameter is but 17", so that the rings extend beyond its poles.

URANUS, unfavourably placed just south of β Scorpii, is in opposition on May 22nd.

NEPTUNE is too near the sun for observation.

METEORS may be looked for specially on May 2nd, 4th, 15th and 31st.

RED STARS IN POSITION DURING MAY AND JUNE:

	R.A.	Dec.	Magni-	
	h. m.	h. m.	tude.	
α Scorpii	16.23	26° 12' S.	1	Fiery
α Herculis	17.10	14° 30' N.	3.5	Orange
S "	16.46	15° 9' N.	6-12	Variable
T "	18.5	31° 0' N.	7-12	Variable
P xviii. 51 Herculis	18.15	29° 38' N.	6.5	Orange red
B. 448, Lyræ	18.28	36° 54' N.	8.5	{ Var., deep crimson

PERRINE'S COMET b, 1898, was discovered at the Lick Observatory on March 20th, situated R.A. 21h. 19m., N. Dec., 16° 43'. It was about equal to a 7th-magnitude star, had a diameter of 2' with considerable central condensation, and a nucleus, with a tail 1' long. Its direction was north-east across Pegasus, Lacerta, Andromeda and Cassiopeia. According to Prof. Schaeberle and Dr. Kistenpart it had passed perihelion on March 18th at a distance of 1.10—earth's mean distance=1.0. It has been slowly decreasing in size almost ever since its discovery.

SUNSPOT GROUP OF MARCH.—The largest spot in this group, according to Mr. Evershed, at the British Astronomical Association Meeting, March 30th, showed unusual activity in the spectroscope, disturbing the C (hydrogen) line in an extraordinary manner, particularly on March 15th, when the line was strongly reversed. On the same day, as Mr. Maunder pointed out, there was a remarkable magnetic disturbance, and in the evening magnificent displays of aurora borealis were seen in various parts of Scotland and the north of England.

THE Lick Observatory is to be under the directorate of Professor J. E. Keeler.

THE Yerkes Observatory is to have a 10-inch photographic telescope, the gift of Miss Catherine W. Bruce, of New York.

GRESHAM COLLEGE Lectures on Astronomy will be delivered by Prof. Rev. E. Ledger, M.A., on May 10th, 11th, 12th and 13th; they will be an introduction to the study of the constellations. The first two dealing with the distances and charting of the stars, the precessional motion and the poles of the Equator, and the origin of the constellations. In the other two the constellations of Ursa Minor and Draco will be considered, also the subject of variable stars in general. These lectures should prove useful. They are delivered at the college in Gresham Street, at 6 p.m., and are free to all



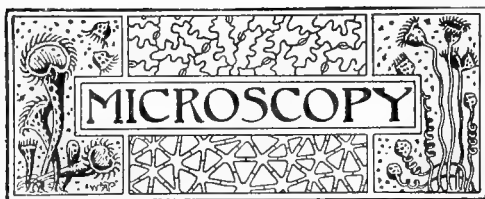

CONDUCTED BY J. H. COOKE, F.L.S., F.G.S.

To whom Notes, Articles and material relating to Microscopy, and intended for SCIENCE-GOSSIP, are, in the first instance, to be sent, addressed "J. H. Cooke, Thorndale, Lincoln."

TO OUR READERS.—When we undertook to conduct the Microscopy section of SCIENCE-GOSSIP in June last, we asked the kind co-operation of our readers. We then pointed out that, to ensure the success of such a department as this, something more than the editorial effort is required, and we asked our readers and workers to second our endeavours by contributing short notes and articles on their own experiences and methods. We shall be glad at all times to receive such contributions whether illustrated or not. We also invite questions and suggestions, both of which shall receive our attention, and, when of general interest, we shall be glad to give them place in these columns. Notes on home-made apparatus, whether for the laboratory or for field work, are always interesting and often valuable; while suggestions on the time, habitat and manner of collecting such material as water-mites, microscopic fungi, algae, *et hoc genus omne* would, we feel sure, be reckoned as desirable information by a large section of our microscopists.

DOUBLE STAINING WITH HAEMATOXYLIN AND SAFRANINE.—In a suggestive paper which was read by Mr. F. A. Upsher Smith before the School of Pharmacy Students' Association on "Quick Double Staining with Haematoxylin," the methods employed for showing the presence of mucilage and nuclei and for contrasting the commoner kinds of vegetable tissues are given in some detail. Mr. Smith does not claim that the methods are original, but in the course of describing these methods he introduces many details of manipulation not to be found in text-books and of a character such as can only be known by actual practice.

CUTTING THE SECTIONS.—The sections, he insists, should be as thin as possible, and the best way to obtain them thus is to flood the freshly stropped razor with liquid like that in which the material is softened, in most cases dilute spirit. When the material has been softened in a moist atmosphere it is generally preferable to cut with a dry razor. Holding the razor in a perfectly horizontal position, draw it firmly and steadily through the material held between the thumb and forefinger of the left hand, and take care that nearly the entire cutting surface of the razor comes in contact with the material in cutting each section. Never cut more than six or eight sections without stropping the razor.

THE HAEMATOXYLIN STAIN.—Place the sections on a clean glass slide and wash with spirit of the same strength as the haematoxylin stain. Cover with haematoxylin stain and leave for a definite time, which must vary with the thickness of the section and the structure of the tissues. From one to five minutes will generally be found sufficient.

THE SAFRANINE STAIN. Wash again with spirit of the same strength as the haematoxylin solution. This washing with spirit of a properly adjusted strength must be carefully performed to ensure success. Spirit washes of a different strength tend to deposit dense particles of colouring matter in the sections. Now cover with safranin solution and allow to stand from one to thirty minutes according to the material employed. Dehydrate the sections by washing with fifty per cent. spirit, then with absolute alcohol, and finally transfer them to clove oil. If only one section is required, choose the best, and manipulate it so that when soaking in clove oil it takes up a position about one-third the length of the slide from one end.

MOUNTING THE SECTION.—Mount permanently by thoroughly drying the central part of the slide, placing upon it a drop or two of Canada-balsam, and quickly transfer the section with a mounted needle to the balsam. Blotting-paper should be at hand in order to quickly absorb the trail of clove oil to prevent it diffusing into the balsam. Place the coverslip in position by lowering it with the left hand until the left side of it dips into the balsam; on lowering the slip rapidly by means of a mounted needle held in the right hand, all bubbles of air may be excluded.

METHODS OF MAKING THE STAINS.—Safranin solution may be made by saturating absolute alcohol with safranin, and mixing with an equal volume of water. For haematoxylin there are many formulæ. Lee's "Microtometist's Vade Mecum" speaks highly of Mayer's haemalum. That stain is made by dissolving a salt of haematein and ammonia in spirit, and adding it to a large volume of alum sulphate in solution. The alum is supposed to be precipitated by some substance present in the cellulose walls, and carries down with it a certain quantity of colouring matter. Lee's book gives the fullest details concerning these and all other known staining reagents.

INDIAN INK IN MICROSCOPY.—Water charged with Indian ink will render visible many organisms that are distinguished with difficulty in water alone. This method is specially to be recommended in the study of many of the algae, and also in investigations of the digestion of the Infusoria and the movements of ciliated organisms.

#### MANIPULATIVE HINTS.—

- (1) Xylol is the best solvent for Canada-balsam, which must first be dried by artificial heat in order to drive off the natural oil contained in it. Chloroform evaporates less quickly than xylol.
- (2) To cause balsam to set expose the slide to a temperature of about 55° C. for about six hours to forty-eight hours. The longer period should be preferred whenever possible.
- (3) It will be found in practice that staining sections on a slide is quicker, cleaner and safer than using a watch-glass. It is obvious that a good section may easily be lost when immersed in a watch-glass containing a comparatively deep layer of a dark stain, and this danger increases with the thinness of the section.

RECENT RESEARCH ON FORAMINIFERA.—The current number of the "Rivista di Paleontologia" contains several interesting reviews of work recently done. *Inter alia*, we note articles by Signor L. Audenino on "The Miocene Pteropods of Mount Cappucini, Torino;" by Dr. C.



Fornasini on "Some of the Foraminifera illustrated by Costa," and a note by Dr. Fornasini on "*Clavulina cylindrica* d'Orb."

THE MYCETOZOA OF ANTIGUA.—We have received a very interesting letter from Mr. W. Cran, describing some of his research work on the Mycetozoa of the West Indies. He has found over fifty species within the last two years in the island of Antigua, and as many of the forms are unique and all are rare and interesting, he has forwarded us the following sketches for publication. Fig. 1, *Stemonitis splendens*, a species fairly common in Antigua, but rather rare in Europe. The type represented is one that has been previously found in Cuba and Borneo. The mesh is small and regular, with a few membranous expansions. Fig. 2, *Cribraria violacea*.—A very pretty species, but rare, having been found before only in Philadelphia,

study comprises one of the most interesting and important chapters in general physiology. The existence of the photogenic function has been demonstrated *de visu* in numerous species belonging to the animal and the vegetable kingdoms, and it might perhaps be found in all living creatures if we possessed instruments of sufficient delicacy to detect it; but this is pure hypothesis. In white algae and mushrooms the photogenic function has been studied in a methodical and scientific manner.

PHOTOGENIC FUNCTIONS OF NOCTILUCA MILIARIS.—The photogenic function is widely found among very inferior animals, the *Noctiluca miliaris*, for example, to which is often due the splendid phenomena of ocean phosphorescence. Besides its envelope, some intercellular liquid, its digestive vesicles, and a flagellum, the structure of a *Noctiluca* is that of an active, contractile, proto-

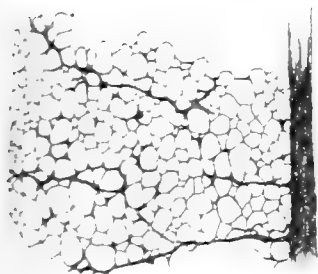

FIG. 1.—*Stemonitis splendens*—unusual type ( $\times 147$ ).



FIG. 2.—*Cribraria violacea*—usual type ( $\times 54$ ).

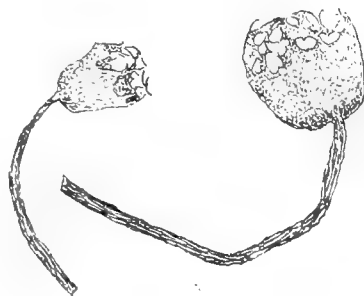

FIG. 3.—*Cribraria violacea*—unusual development ( $\times 54$ ).



FIG. 4.—CHIGOE ( $\times 15$ ).

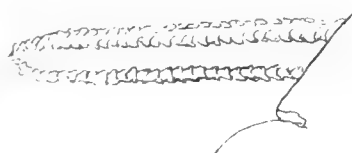

FIG. 5.—PART OF PROBOSCIS OF CHIGOE ( $\times 300$ ).



FIG. 6.—DEVELOPING EGGS OF CHIGOE. Extracted from human foot ( $\times 15$ ).

U S.A., and at Ivinghoe, Bucks. Fig. 3 represents two unusual developments of the same species.

THE CHIGOE.—Mr. Cran also sends studies of *Fulex fenestrans*, the chigoe or chegre of the West Indies (fig. 4), drawn from a glycerine jelly mounting of one that was captured before it had yet made its way into the foot. It is common here, unfortunately, but is seldom captured and mounted in such good condition. Fig 5.—One half of the rostrum of the same, as seen projecting under the foreleg of the above drawing. This was drawn under a one-twelfth inch oil-im. lens. Fig. 6.—The eggs of chigoe extracted from the human foot, and preserved in glycerine jelly.

PHOTOGENIC ORGANISMS.—One of the most curious phenomena of life is unquestionably the property possessed by certain organisms of radiating into space, as luminous variations, a part of the energy that animates them. The light being physiological in its origin, Professor Dubois has called its production the photogenic function. Its

plasmic mass, surrounding a nucleus, and sending toward the internal wall of its envelope numerous retractile and excitable prolongations. It is in this last tract that we see formed rounded granulations having a special refractive power that is to be found in all photogenic elements. Mechanical, physical, and chemical stimuli cause the interior of the *Noctiluca* to shine, and they then appear to the naked eye like little stars emitting a steady light. Under the microscope this apparent uniform glow is resolved into a multitude of little brilliant points or sparks that, by their form and distribution, correspond to the refringent granulations of which we have already spoken.

PARASITE OF RABIES.—Dr. A. Grigorjew believes that the exciting cause of hydrophobia is not a bacterium, but a body belonging to the Protozoa. He has isolated from animals suffering from rabies a body with slow amoeboid movements, and exhibiting extension of pseudopodes. Its action may even be modified by the presence of bacteria.



CONTRIBUTED BY FLORA WINSTONE.

BULLETIN DE LA SOCIÉTÉ ZOOLOGIQUE DE FRANCE (Paris, January and February, 1898.) In looking through this number, one is struck by the activity now being shown in France for the protection of the fast disappearing fauna of that country. In a speech on the occasion of the annual dinner of the Zoological Society of France, Professor Bureau called on those interested in zoology to use their best endeavours to protect in France the inoffensive species of birds and mammals whose destruction is largely due to a desire for gain, or even a wanton pleasure in killing. He especially mentioned the beaver. In 1889 there were only seventy or eighty known specimens left in the country, though the removal in 1891 of a reward of fifteen francs a head for their extermination has done much towards arresting the active crusade against this little animal. The wild goat, he says, has entirely vanished from the Alps, Pyrenees and Swiss mountains, but it is still occasionally found in Upper Savoy and upon the heights of Courmayeur, which overlook the Valley of Aost, and a few other places. Among cetaceous animals, *Balaena biscayensis* is now rarely seen upon the shores of France, though in the last century it was the source of a large industry on the coasts of France and Spain. With regard to birds, he mentions especially the bustard, at one time so plentiful on the plains of Champagne and in the neighbourhood of Chalons-sur-Marne, now completely disappeared. The heron is no longer seen except in preserved heronries. Many other examples are given. Those interested in this subject will do well to refer to "La Feuille des Jeunes Naturalistes" for December, 1897, and February, 1898 (SCIENCE-GOSSIP ante p. 302). On February 25th, at a meeting of the Zoological Society, Professor Cuénot gave an address on "The Means of Defence possessed by Animals."

TERMÉSZETRAJZI FÜZETEK (Budapest, March, 1898). This number contains, among many others, an article by Dr. Emerich Löwenthey, in German, upon a work recently issued by Max Hantken v. Prudnik, on the "Decapoda of the Tertiary Strata near Budapest." Nine beautiful plates, produced in the usual excellent manner of this magazine, illustrate the paper. The text and the plates are both indexed. Professor L. v. Méhelj contributes an account in English of "The Reptiles and Batrachians collected by M. Biró in New Guinea," with one plate, containing eleven figures. Some further specimens collected by Signor Luigi Biró from New Guinea are described in Italian by Prof. Giovanni Canestrini: families Trombididae, Oribatidae, Nothridae and Uropodidae of the Acaroidae are the subjects of this month's paper. Herr Sándor-tol-Mocsáry contributes some notes in Hungarian on the Hymenoptera of Hungary. Professor Joannes Thalhammer describes in Latin a new dipteran, which he names *Elachiptera pubescens*. Full particulars of a new species of the hymenopterous group Cecidomyia

are given in Hungarian by Dr. Kertész Kálmántól, it is named *Asphondylia riibsaameni*, and is illustrated by eight anatomical figures in the text, and one of the manner of feeding in the flowers and fruit of *Asphondylia pimpinellae*, one of the Umbelliferae.

LA FEUILLE DES JEUNES NATURALISTES (Paris, 1898.) In the March number of this journal, M. Plateau commences a series of articles upon the "Gravel of the Lower Stratum" at Chalons-sur-Vesle, in the neighbourhood of Rheim; it has two illustrations. A synoptic study of Coleoptera, more especially the Longicornes, is contributed by M. Maurice Pic: this is also the first of a series. In this number the genus *Cortodera* is discussed. M. Ernest André continues his synopsis of the Mutillides of France. M. Emile Anfré writes on the "Birds in the Calvadas," joining, as he says, his opinions with those of MM. X. Raspail, C. Van Kempen and Lomont, as to the rapid disappearance of various species of birds in the different Departments of France; more especially the Insectivores. He advocates immediate and effectual protection. (April and May.) M. L. Vignal gives a study, accompanied by a plate with ten figures, on the "Potamides of the Eocene Period at Gaas," the shells belonging chiefly to the family Cerithiidae *Gagea foliosa* (Roem and Schult), is fully described in an article with two illustrations, by M. C. de Rey-Pailhade. This plant, new to the flora of France, was discovered last year in the neighbourhood of Beziers, by Brother Sennen, director of the Christian school at Prades. M. G. de Rocquigny-Adanson writes of the altitudes at which *Saturnia pyri* (Schieff) is found. The minimum height, says he, is about the fruit garden of Derbent in the Caucasus, situated upon the shores of the Caspian. In Central France, at Moulins, this moth has been captured at 200 and 250 metres above the sea. In Switzerland, the caterpillar has been found at 300 metres. The highest altitude at which it has at present been found is on the mountains of Western or Central Europe, such as in the Pyrenees, Vosges, Jura, Alps, Boehmerwald and Carpathians at 1,500 metres. The "Synopsis of the Mutillides of France," by M. Ernest André, is completed in this number. It also contains the completion of M. Maurice Pic's notes on Coleoptera, which deals especially with the genus *Cortodera*. From the pen of M. W. Broeleman there are some particulars of the "Centipedes around Avignon." The district of the Lirac, he says, is a particularly favourable neighbourhood for divers forms.

PROCEEDINGS OF THE ACADEMY OF NATURAL SCIENCES, PHILADELPHIA (Philadelphia, 1898). In the January part, Mr. Thomas Meehan read a paper on "The Plants of Lewis and Clark's Expedition across the Continent, 1804-1806." The account of this journey is extremely interesting, if only for the sake of showing the advance made in botanical knowledge. It is uncertain what became of the collection made by Captain Lewis and Mr. Clark. Part of the herbarium made during the ascent of the Rocky Mountains and the Northern Andes was unfortunately lost, and the history of the rest cannot be clearly traced, though about two years ago search was made, at the suggestion of Professor C. Sargent, among the property of the American Philosophical Society, with the result that some packages of plants were found that from various evidence were considered to be some of those collected by Captain Lewis.



THE SOUTH LONDON ENTOMOLOGICAL AND NATURAL HISTORY SOCIETY.—February 24th, 1898. Mr. J. W. Tutt, F.E.S., President, in the chair. Mr. Samuel Stevens exhibited several fine varieties of Lasiocampid moths, including bright yellow-brown *Bombyx trifolii*, *B. quercus*, with semi-transparent hind wings, a dark well-banded *B. rubi* and a remarkably light *Lasiocampa quercifolia*. Mr. J. A. Clarke, his series of the Lasiocampidae, including many fine and extreme forms of variation. Mr. R. Adkin, fine series and varieties of many of the same family. Mr. Tutt, an inbred series of *Zygaena filipendulæ*, showing the gradual coalescence of the spots and the usual order of this joining; a *Brepfos parthenias*, from Leicester, having yellow hind wings; and a yellow variety of *Arctia fuliginosa*. Mr. F. Clarke, photo-micrograph of the curious scales of the aberrant lepidopteron, *Pseudopontia paradoxa*. Mr. Tutt read a paper entitled, "The Lasiocampid Moths," illustrating it with specimens, diagrams and the blackboard. A discussion ensued, Dr. Chapman, Messrs. J. A. Clarke, R. Adkin, S. Stevens, Hillsworth, McArthur and Tutt taking part.—March 10th. Mr. J. W. Tutt, President, in the chair. The evening was devoted to the exhibition of a large number of admirable photo-micrographs made by Mr. Fred Clark, together with a number of slides showing details of the Odonata (dragonflies) made by Mr. Lucas. The slides were of particular interest, as the objects were chosen, in many cases, by other members, and handed to Mr. Clark, who photographed and most skilfully manipulated them for exhibition in the Society's lantern.—Hy. J. Turner, Hon. Report. Sec.

CITY OF LONDON ENTOMOLOGICAL SOCIETY.—At the meeting of 15th March, exhibits: Rev. C. N. Burrows, a series of *Calligenia miniata*, showing considerable variation, some with scarcely any black markings on the fore wings, some orange, and two quite yellow in colour instead of the usual pink or pale red. Mr. A. W. Mera, a cocoon of *Eriogaster lanestrus*, which he had broken into, and in which he had found the larval skin of the caterpillar, two pupal cases of parasitic diptera, one large and one small, and the attenuated corpse of the dipteron, which had emerged from the larger pupa, but which had not been able to escape from the compact walls of the cocoon. The lid of the smaller pupal skin was raised, and the legs of a dipterous imago protruded, but the fly had died in the skin, there being no room for its emergence. Mr. L. B. Hall, a visitor, passed round a box containing a large bug, *Enoplops uapha*, and four beetles, male and female, *Athous diffusus*, a species only found in the South of England, the female being very scarce, and having the thorax more spherical than the male, and male and female *Campylus linearis*. In this latter species the female is scarcer than the male, and has the elytra generally black, with testaceous borders, the elytra of the male being testaceous. All five insects were captured at Hastings. Mr. H. Heasler,

series of *Scaaphidium 4-maculatum*, taken under a rotten oak-log at West Wickham in February. The undersides of male and female were shown, the centre of the metasternum of male being depressed and pubescent. Also, series of *Agathidium varians*, taken under a decayed branch at West Wickham. The male has the left mandible produced, a peculiar character which is present in varying stages of development in other members of the same genus. The members of the genus have the power of rolling themselves up into a ball. Also, several specimens of *Ennearthron affine*, taken in two small pieces of dry *Boletus* fungus. Mr. E. M. Dadd read a paper translating and summarising Standfuss' work on "Causes of Variation." Discussion followed, especial interest being shown in the author's definitions of albinism and melanism. Mr. Tutt, Dr. Chapman, and Messrs. Prout, Nicholson and H. Heasler took part, Dr. Chapman being of opinion that the reason why albinic specimens occur sporadically whereas melanic tend to increase and found a race, might be explained by the fact that albinism is a sign of weakness in the individual, whilst melanism is the result of special vigour, and thus albinos die off, but melanic individuals transmit their variation to their progeny. Mr. Dadd was thanked for his care and labour in the translation.—April 5th. Exhibits: Mr. L. B. Prout, a very uncommon variety of *Covema spadicearia (ferrugata)* bred from ova obtained by Mr. E. M. Dadd from a female captured at Little Berkhamsted. The centre of the red band was almost as pale as the ground colour. Mr. H. Heasler, a beetle (*Harpalus foelichii*) new to the British list, taken by Mr. Claude Morley. Dr. J. S. Sequeira, species of *Lucanus* from India. In field work, Mr. E. M. Dadd, with a party of fellow members, had visited Oxshott on March 24th, and reported about fifty specimens of *Pachycnemis hippocastanaria* had been beaten; the sawflies were backward, and only four species of *Taeniocampa* were seen—*stabilis*, *pulverulenta (cruda)*, *gothica* and *munda*. Communication: Mr. C. Nicholson read a letter from Mr. Potter, of Whangarei, New Zealand, asking for a specimen of *Phylloxera vastatrix* for comparison with a pest of the vine in his district, and an extract from a newspaper of the same place giving high praise to our member, who succeeded in rearing from the egg in some numbers the beetle *Cryptolaemus montrouzia* which had been introduced into the district to exterminate the mealy bug, *Dactylopius adonidum*, the consignment of eggs entrusted to the Government having perished, and thus all hopes of relief from this pest were centred in Mr. Potter, who possessed the only existing specimens in the locality. A paper by Mr. J. W. Tutt, on "The Protective Coloration and Defensive Habits of Lepidopterous Larvæ," dealt with such features as the longitudinal lines on grass-feeding larvæ, the likeness to twigs of Geometrids, the manner in which hair is thickened, and tubercles transformed into spines in some cases, and of larvæ which resemble gall-like structures on leaves, withered edges of leaves and even bird-droppings. Numerous instances were quoted illustrating these points, and mention was also made of larvæ defending themselves by attitude, by excretions and odours, and by such habits as twisting leaves, making silken webs and galleries, spinning leaves together, feeding by night, dropping if disturbed, or flinging themselves about in contortions. In the discussion which ensued Mr. Bacot spoke of the swinging of *Pericallia syringaria* if disturbed, which he compared

to the movement, caused by wind, of a loose-hanging twig. Mr. Prout instanced *Notodonta ziczac* as resembling a withered edge of a disreputable-looking sallow leaf. Mr. Dadd and Mr. Nicholson gave instances bearing out points in the paper, such as the green and brown forms of larvæ of *Phlogophora meticulousa*, *Mamestra persicariæ* and *Euplexia lucipara*, each form finding its colour valuable for protection according to its food-plant.—H. A. Sauzè, Hon. Sec., 4, Mount Villas, Sydenham Hill Road, S.E.

ROYAL METEOROLOGICAL SOCIETY. — The monthly meeting of this society was held on Wednesday evening, April 20th, at the Institution of Civil Engineers, Mr. F. C. Bayard, LL.M., President, in the chair. Major H. E. Rawson, R.E., read a paper on "Anticyclonic systems and their movements." Cyclones and anticyclones have long been recognised as powerful weather controls and their movements studied, but up to the present very little has been written in this country upon the progressive movements of the cores of the permanent high-pressure areas which are found to be associated with certain localities at different times of the year. The author referred to previous investigations by Abercromby, Scott, Loomis, H. C. Russell, and Buchan, and then proceeded to give the results of an examination which he had made of all the available synoptic weather charts for the eleven years, 1881 to 1891. During this period there were 212 cases in which the centre or core of an anticyclonic system was over the British Isles, and of these 130 were due to the Atlantic system, forty-one to the Scandinavian, and seventeen to the Greenland, twenty-two to the Atlantic and Scandinavian systems extending and merging together, and two to the same thing occurring in the case of the Atlantic and Greenland systems. It is thus evident that we owe the greatest number of our anticyclones to the Atlantic system. They occur in all months but more especially in January, June and October, and are least frequent in April and November. When such anticyclones move away from our area, the direction is very much influenced by the season of the year. By far the largest number drift off in some direction between north-east, through east to south, and take the more southerly course in December, January and February. Some few between April and July move west and south-west, and still fewer north or north-west. The Hon. F. A. Rollo Russell described the results of observations which he had made on haze and transparency during 1897. He found that the greatest clearness occurred with winds from the westward, and the least clearness with winds from the eastward. The highest mean visibility was twenty-four miles with west winds, and the lowest mean visibility was 10.6 miles with north-east winds.

HULL SCIENTIFIC AND FIELD NATURALISTS' CLUB.—At a recent meeting "The Marine Fauna of the Yorkshire Coast" was the title of a paper read by Mr. F. W. Fierke, M.C.S., the Club's Recorder for Marine Biology. Mr. Fierke explained that there was probably no branch of natural history that had been so much neglected on our coasts as Marine Biology. The Plymouth, Liverpool, Essex and Scotch Marine Biological Associations, judging from their publications, have been doing very good work for some time. So far as the coast in the south-east of Yorkshire is concerned, the cliffs and beach from Spurn Point

to Filey, and perhaps as far as Scarborough, should be thoroughly explored and examined by the members of the Hull Scientific and Field Naturalists' Club. The only drawback is the difficulty of reaching the various points most likely to reward observation. The cliffs between Spurn and Bridlington being of boulder clay throughout, and the beach also being of a similar character the whole length, do not afford the variety of objects necessary to make an excursion prolific in good finds; nevertheless, there is much to be done even in this part of the coast. The material thrown up by the waves at high-tide mark is always full of interesting objects. Spurn Point itself, especially on the Humber side of that tongue of land, should prove a most interesting region for research, and much benefit would be derived by carefully comparing the specimens found on the Humber side with those found on the opposite beach. At Flamboro' and Filey, however, the rocks and scars, with the huge boulders, sheltered ledges of rock, and pools of clear water, afford habitation to many deeply interesting forms of marine life, and jelly-fishes, star-fishes, sea-urchins, sea-anemones, crabs, etc., in endless variety are to be found in plenty, in addition to a large variety of marine shells. By the aid of lantern views, Mr. Fierke pointed out the many delightful hunting-grounds amongst the rocks and pools of Flamboro' Head, and also showed a great number of the different types of marine life there to be met with. The Brig and Spittle at Filey were also recommended as profitable localities for a day's collecting. The Spittle, unfortunately, is only accessible at very low tides, when a good variety of specimens can be secured. The shells, etc., which occur on the coast, are arranged in definite and well-defined zones. For instance, between high and low watermark, the littoral zone, a certain class of life forms is met with which differs from that immediately below the low-tide mark, viz., the laminarian zone. This latter, however, is of the greatest interest to a marine zoologist. Mr. Fierke illustrated his paper by an excellent series of slides on the screen, representing the various objects found on our coast as well as views of the places at which they are secured.—T. Sheppard, Hon. Sec., 78, Sherburn Street, Hull.

GREENOCK NATURAL HISTORY SOCIETY.—At a meeting held March 31st, in the Maclean Museum, the President, Mr. M. F. Dunlop, in the chair, Mr. John Ballantyne, Rothesay, read two papers, one on "The Hornet Sawfly (*Sirex gigas*)," and the other on "Fern Structure." With regard to the saw-fly, he said he had obtained much interesting information from the foresters and woodmen employed in the woods of Arran, Bute, and Ormidale, the insect having been observed in these localities during the last twenty or twenty-five years. The female fly, which measures from one-and-a-half to two inches in length from the head to the point of the ovipositor, lays her eggs underneath the bark of the Scotch fir. When the eggs are hatched the larvae feed on the wood, and in doing so bore passages of circular section, leaving the remains of the partly digested sawdust behind as a nearly solid plug. The flies from the larvæ under Mr. Ballantyne's observation emerged from the wood at the beginning of August. Last July one of these saw-flies was captured at Rothesay Harbour on a pile of spruce deals that had formed part of a cargo from Quebec. In addition to the flies themselves, there were shown at the meeting

specimens of Scotch fir from Merklund Wood, near Brodick Castle, Arran, which on being cut up at the saw-mill had been found to contain a large number of larvæ. The paper on "Fern Structure" was illustrated by means of the lantern and slides shown under microscopes. Mr. M. F. Dunlop was elected the Society's representative to the Committee of the Millport Marine Biological Station.—*G. W. Niven, Hon. Sec., 23, Newton Street, Greenock.*

## NOTICES OF SOCIETIES.

LONDON GEOLOGICAL FIELD CLASS.—Conductor, Professor H. G. Seeley, F.R.S.

May 7.—Greenwich Park and Charlton: erosion of sands. Lower Tertiary rocks.  
 " 14.—Aylesbury: strata below the chalk north of London.  
 " 21.—Highgate and Hampstead: influence of sand in preserving and eroding clay.  
*Hon. Class Secretary (First Series), Stephen Miall, B.Sc., LL.D., 4, Endsleigh Street, W.C.*

June 4.—Hayward's Heath and Cuckfield: strata below the chalk south of London.  
 " 11.—Nutfield to Redhill: a hill range of sandstone. Lower Greensand.  
 " 18.—Marden Park and Godstone: a hill range of limestone. Chalk and upper greensand.  
 " 25.—Ascot and Bracknell: hills on a sandstone plain. Bagshot sand and London clay.  
 " 2.—Sevenoaks: parallel valleys and hills of stratification. Weald to chalk.  
*Hon. Class Secretary (Second Series), J. W. Jarvis, St. Mark's College, Chelsea, S.W.*

GEOLOGISTS' ASSOCIATION OF LONDON.

## Excursions and Conductors:

May 7.—Rugby, Warwickshire. Beeby Thompson, F.G.S.  
 " 14.—Ayot, Hertfordshire. A. E. Salter, B.Sc., F.G.S.  
 " 21.—W. P. D. Stebbing, F.G.S.  
 " 28 to 31.—Aldeburgh, Suffolk. W. Whitaker, F.R.S., Pres. G.S., F. W. Harmer, F.G.S., and E. P. Ridley, F.G.S.  
 June 11.—Godalming, Surrey. T. Leighton, F.G.S.  
 " 18.—Crowborough and Eridge, Kent. R. S. Herries, M.A., F.G.S., and Dr. G. Abbott.  
 " 25.—Sudbury, Suffolk. J. W. Gregory, D.Sc., F.G.S.  
 July 9.—Isle of Sheppey, Kent. W. Whitaker, F.R.S., Pres. G.S., and T. V. Holmes, F.G.S.  
 " 16.—Worthingham, Surrey. W. Whitaker, F.R.S., Pres. G.S.  
 " 25 to Aug. 3.—Birmingham, Nuneaton, Dudlev, Lickey, Cannock, etc. Prof. C. Lapworth, LL.D., F.R.S., W. W. Watts, M.A., F.G.S., W. J. Harrison, F.G.S., and W. Wickham King, F.G.S.  
 Sept. 10.—Gravesend, Kent. G. E. Dibley, F.G.S.

Further particulars from *Horace W. Mouchton, Hon. Sec., Excursions, 10, King's Bench Walk, Temple, E.C.*

BATTERSEA FIELD CLUB AND LITERARY AND SCIENTIFIC SOCIETY, Public Library, Lavender Hill, S.W.

## Excursions:

May 28.—Hayes and Keston Commons. Conducted by the Hon. Sec.  
 June 11.—Anstebury and Leith Hill. Conducted by G. W. Young.  
 " 25.—Whole day Excursion to Sea-side.  
*Hon. Sec. E. J. Davies, Murrey Road, Clapham Common*

LAMBETH FIELD CLUB AND SCIENTIFIC SOCIETY, St. Mary Newington Schools, Newington Butts, S.E.

May 2.—Lecture "Spring Flowers." E. J. Davis.  
 " 29.—Whit Monday Outing. Reigate.  
 June 6.—Annual Meeting  
 " 11.—Outing—Shirley Hills and Addington Woods.  
 " 23.—Outing—Perivale and Hornendon Hill.

*Hon. Sec., H. Wilson, 14, Melbourne Square, Bristol Road.*

SOUTH LONDON NATURAL HISTORY SOCIETY.

May 5.—Discussion: "Nebulæ." Opened by C. Nicholson, F.E.S.  
 " 21.—Half-day Excursion to Epping Forest.  
 " 27 to 29.—Excursion to the New Forest—leader, L. J. Tremayne  
 " 30.—Alternative whole day Excursion to Shere.  
 June 19.—"The Catceolidae." E. M. Dadd  
 " 18.—Whole day Excursion to Deal—leader, L. J. Tremayne

Visitors will be cordially welcomed at all meetings and excursions. *Lawrence J. Tremayne, Hon. Sec.*

SOUTH LONDON ENTOMOLOGICAL AND NATURAL HISTORY SOCIETY.

May 12.—"South European Lepidoptera." A. H. Jones, F.E.S.  
 6.—Geological Lecture with Lantern Illustrations.

HULL SCIENTIFIC AND FIELD NATURALISTS' CLUB.

May 7.—Excursion to North Cave.  
 " 11.—Paper: "Side Lights on the Hand." G. Ross.  
 " 14.—Excursion to Swine.  
 " 18.—Meeting.  
 " 21.—Excursion to Aldborough (waggonettes).  
 " 25.—Exhibition of Spring Flowers by the Members.  
 " 28.—Excursion to Hornsea Mere.  
 " 30.—Excursion to Doncaster with the Yorkshire Naturalists' Union.  
 June 1.—Meeting.  
 " 4.—Walk by River Hull Bank, Dunswell to Beverley.  
 " 8.—Microscopic Exhibition. Members.  
 " 11.—Excursion to Kelsey Hill.  
 " 18.—Excursion to Skipsea (waggonettes from Hornsea).  
 " 22.—Lecture: "Foraminifera," illustrated. R. H. Philip.  
 " 25.—Excursion to Barton and South Ferriby.  
 " 29.—Meeting.

Meetings are held at 72, Prospect Street, 8 p.m.  
*T. Sheppard, Hon. Sec.*

LINCOLNSHIRE SCIENCE SOCIETY.

## Excursions and Conductors:

May 4.—Market Rasen and District: woods, ponds and quarries. G. A. Grierson, F.L.S., and Rev. E. Nelson, M.A.  
 " 21.—Langworth and Sudbrooke Holme: cornbrash and glacial beds; implementiferous gravels. Dr. G. M. Lowe.  
 June 11.—Swan's Pit, for sub-divisions of the Lias. J. H. Cooke, F.G.S., who will give an address on "The Geology of Lincoln City."  
 " 29.—Scawby Woods.  
 July 16.—Skellingthorpe and Doddington woods, ponds and Old Trent gravels.  
 Sept. 3.—Barkstone, for Syston and Belton Parks. Rev. E. Nelson, M.A.  
 " 21.—Woodhall Spa: botany of the Moors; glacial beds.  
 Oct. 8.—Torksey: Old Trent gravels. W. E. Asquith.

*Hon. Sec., G. A. Grierson, F.L.S., 312, High Street, Lincoln.*

NOTTINGHAM NATURAL SCIENCE RAMBLING CLUB.

## Conductors of Rambles:

*Geology, J. Shipman, F.G.S.; Botany, W. Stafford.*

May 7.—Geology. Meet at tram terminus, Trent Bridge, 3 p.m., to Radcliffe, etc., for study of Trent Valley formation. Fare and tea, 1s. 3d.  
 " 21.—Botany. Meet at tram terminus, Mansfield Road, 2.30 p.m., for Edward's Lane and Mapperley.  
 June 4.—Geology. Meet under clock, G.N.R. Station, 2.15 p.m., for Kimberley: coal measures, magnesium limestone, etc. Fare and tea, 1s. 9d.  
 " 18.—Botany. Meet at Midland Station, 2.15 p.m. Attenborough and Burton.  
 July 2.—Geology. Meet at Midland Station, 1.15 p.m., for Mansfield: sandstone, etc. Fare and tea, 3s. 3d.  
 " 16.—Botany. Meet at Midland Station, 1.15 p.m., for Hucknall.  
 " 30.—Geology. Meet in front of University College, Shakespeare Street, 2.30 p.m., drive to East Leake and Gotham: marls, shales, gypsum, etc. Fare and tea, 2s. 6d.; tickets to be taken before July 30.  
 Aug. 13.—Botany. Meet at Emmanuel Church, Woodborough Road, 2.30 p.m., for Lambley Dumbles.  
 " 27.—Geology. Meet at Sneinton Baths, 2.45 p.m., for Colwick for Bunter Pebble Beds, Keuper strata, etc.  
 Sept. 10.—Botany. Meet at Lodge, Waverley Street entrance to Examiners' Arboretum and Fater Herbarium at University Museum.  
 Oct. 29.—Annual Meeting and Exhibition, 4.15 p.m., Natural Science Laboratory, University College.  
*Hon. Sec., W. Richeson, 187, Nudd Street.*

SCARBOROUGH FIELD NATURALISTS' SOCIETY.

May 5.—"Anemones." J. C. Harrison  
 " 16.—Y.N.U. Excursion to Clapham for Bowland, Notts  
 " 19.—"An Ardent Entomologist." T. W. Lowisbrough.  
 " 30.—Y.N.U. Excursion to Doncaster for Dalham and Sandal  
 " 2.—"Chara and Nitella their structure, life and beauty." D. W. Bevan.  
 16 "Stems." Miss Major.

June 18.—Y.N.U. Excursion to Hovingham and Wiggan-  
thorpe.

" 30.—Marine Conversazione.

Meetings held in the Museum at 8.15 p.m.

Hon. Secs., E. K. Cross and H. Herbert, 75, Prospect Road.

TUNBRIDGE WELLS NATURAL HISTORY SOCIETY.

May 6.—Annual Meeting.

Ordinary Meetings in the Literary Society's Library,  
32, Pantiles, on Friday evenings at 8.—Miss Cooke,  
Hon. Sec., 19, Guildford Road.

#### METROPOLITAN SCIENTIFIC SOCIETIES.

The following is a list of societies in the London district devoted to natural science, with hours and places of meeting. They may be visited with introduction from a Fellow, Member, or Secretary. Will secretaries send additions or corrections

ANTHROPOLOGICAL INSTITUTE OF GREAT BRITAIN, 3,  
Hanover Square. Second and fourth Tuesdays at  
8.30 p.m., November to June.

BATTERSEA FIELD CLUB AND LITERARY AND SCIENTIFIC  
SOCIETY. Public Library, Lavender Hill, S.W. Thurs-  
days, 8 p.m.

CITY OF LONDON COLLEGE SCIENCE SOCIETY, White Street,  
Moorfields, E.C. Last Wednesday in each month,  
October to May, 7.30 p.m.

CITY OF LONDON ENTOMOLOGICAL AND NATURAL HISTORY  
SOCIETY, London Institution, Finsbury Circus. First  
and third Tuesdays, 7.30 p.m.

CONCHOLOGICAL SOCIETY, LONDON BRANCH, St. Peter's  
Rectory, Walworth. Irregular meetings. Rev. J. W.  
Horsley, President, will answer enquiries.

CROYDON MICROSCOPICAL AND NATURAL HISTORY CLUB,  
Public Hall. Third Tuesdays, October to May, 8 p.m.

DULWICH SCIENTIFIC AND LITERARY ASSOCIATION. Fort-  
nightly lectures Lordship Lane Hall, second and fourth  
Mondays, 8.15 p.m., from October, for winter season.

EALING NATURAL SCIENCE AND MICROSCOPICAL SOCIETY.  
Victoria Hall, Ealing. Second and last Saturdays.  
October to May, 8 p.m.

ENTOMOLOGICAL SOCIETY, II, Chandos Street, Cavendish  
Square. First Wednesday, October to June (except  
January). Third Wednesday, January, February, March  
and November, 8 p.m.

GEOLOGISTS' ASSOCIATION, University College, Gower  
Street. First Friday, 8 p.m., November to July.

GEOLOGICAL SOCIETY OF LONDON, Burlington House,  
Piccadilly. First and third Wednesdays, 8 p.m.,  
November to June.

GREENHITHE NATURALISTS' AND ARCHÆOLOGICAL SOCIETY,  
7, The Terrace. First Fridays, 7 p.m.

LAMBETH FIELD CLUB AND SCIENTIFIC SOCIETY, St. Mary  
Newington Schools, Newington Butts, S.E. First Mon-  
days all the year and third Mondays in winter, 8 p.m.

LINNEAN SOCIETY OF LONDON, Burlington House, Piccadilly.  
First and third Thursdays at 8 p.m., November to June.

LONDON AMATEUR SCIENTIFIC SOCIETY, Memorial Hall,  
Farringdon Street, E.C. Fourth Friday in each month,  
October to May, 7.30 p.m.

LUBROCK FIELD CLUB, Working Men's College, Great  
Ormond Street, Bloomsbury, W.C. Excursions second  
Sundays. Meetings following Mondays, 8 p.m.

MALACOLOGICAL SOCIETY OF LONDON, meets in Linnean  
Society's Rooms, Burlington House. Second Friday  
each month, November to June, 8 p.m.

MINERALOGICAL SOCIETY. Meets in rooms of Geological  
Society, February 4th, April 14th, June 23rd, November  
17th, 8 p.m.

NONPAREIL ENTOMOLOGICAL AND NATURAL HISTORY  
SOCIETY, 99, Mansfield Street, Kingsland Road, N.E.  
First and third Thursdays, 8 p.m.

NORTH KENT NATURAL HISTORY AND SCIENTIFIC SOCIETY.  
St. John's Schools, Wellington Street, Woolwich.  
Alternate Wednesdays, 7.30 p.m.

NORTH LONDON NATURAL HISTORY SOCIETY, North-East  
London Institution, Hackney Downs Station. First  
and third Thursdays, 7.45 p.m.

QUEKETT MICROSCOPICAL CLUB, 20, Hanover Square. First  
and third Fridays, 8 p.m.

ROYAL BOTANIC SOCIETY OF LONDON, Regent's Park.  
Second and fourth Saturdays at 3.45 p.m.

ROYAL HORTICULTURAL SOCIETY, 117, Victoria Street, S.W.  
Second and fourth Tuesdays, except December to  
February; 2 p.m. on show days, which vary.

ROYAL METEOROLOGICAL SOCIETY, 22, Great George Street,  
Westminster. 3rd Wednesday, November to June, 8 p.m.

ROYAL MICROSCOPICAL SOCIETY, 20, Hanover Square.  
Third Wednesdays, October to June, 8 p.m.

SELBORNE SOCIETY, 20, Hanover Square. No winter  
meetings.

SIDCUP LITERARY AND SCIENTIFIC SOCIETY, Public Hall,  
Sidcup. First and third Tuesdays, October to May, 8 p.m.

SOUTH LONDON ENTOMOLOGICAL AND NATURAL HISTORY  
SOCIETY, Hibernia Chambers, London Bridge, S.E.  
Second and fourth Thursdays, 8 p.m.

SUTTON SCIENTIFIC AND LITERARY SOCIETY, Public Hall  
Chambers. Second and fourth Tuesdays, 8 p.m.

WEST KENT NATURAL HISTORY, MICROSCOPICAL AND  
PHOTOGRAPHIC SOCIETY. Meets in School for Sons of  
Missionaries, Blackheath, third Wednesday, in Decem-  
ber, fourth Wednesdays in October, November, January,  
February, March, April, May, 8 p.m.

ZOOLOGICAL SOCIETY OF LONDON, 3, Hanover Square. First  
and third Tuesdays, 8.30 p.m., November to August.

## NOTICES TO CORRESPONDENTS.

TO CORRESPONDENTS AND EXCHANGERS.—SCIENCE-GOSSIP  
is published on the 25th of each month. All notes or other  
communications should reach us not later than the 18th of  
the month for insertion in the following number. No com-  
munications can be inserted or noticed without full name  
and address of writer. Notices of changes of address  
admitted free.

BUSINESS COMMUNICATIONS.—All Business Communi-  
cations relating to SCIENCE-GOSSIP must be addressed to the  
NASSAU STEAM PRESS, LIMITED, 86, St. Martin's Lane,  
Charing Cross, W.C.

SUBSCRIPTIONS.—Subscriptions to SCIENCE-GOSSIP, at the  
rate of 6s. 6d. for twelve months (including postage), should  
be remitted to the NASSAU STEAM PRESS, LIMITED, 86, St.  
Martin's Lane, Charing Cross, W.C.

Strictly Editorial communications, *i.e.*, such as relate to  
articles, books for review, instruments for notice, specimens  
for identification, etc., to be addressed to JOHN T. CARRING-  
TON, 1, Northumberland Avenue, London, W.C.

NOTICE.—Contributors are requested to strictly observe the  
following rules. All contributions must be *clearly* written  
on one side of the paper only. Words intended to be  
printed in *italics* should be marked under with a single line.  
Generic names must be given in full, excepting where used  
immediately before. Capitals may only be used for generic,  
and not specific names. Scientific names and names of  
places to be written in round hand.

The Editor will be pleased to answer questions and name  
specimens through the Correspondence column of the maga-  
zine. Specimens, in good condition, of not more than three  
species to be sent at one time, *carriage paid*. Duplicates  
only to be sent, which will not be returned. The specimens  
must have identifying numbers attached, together with  
locality, date and particulars of capture.

The Editor is not responsible for unused MSS., neither  
can he undertake to return them, unless accompanied with  
stamps for return postage.

#### EXCHANGES.

NOTICE.—Exchanges extending to thirty words (including  
name and address) admitted free, but additional words must  
be prepaid at the rate of threepence for every seven words  
or less.

WANTED, living ova, larvæ or pupæ in return for photo-  
graphic literature, etc.—Charles Mosley, 2, Woodside Road,  
Lockwood, near Huddersfield.

FOREIGN postage stamps offered for foreign land and  
marine shells.—A. K. Lane, 41, Rufford Road, Liverpool.

OFFERED, British and foreign shells in exchange for others  
not in collection, or for anything useful, or books, plants;  
correspondence invited; lists sent.—Mrs. Heitland, The  
Priory, Shrewsbury.

POCKET lens, for insects, etc., three powers; what offers?  
Unio margaritifera for other shells or postage stamps.—Rev.  
W. W. Fleamyng, Coolfin, Portlaw, co. Waterford.

OFFERED, "British Coalfields," with map, by Hull;  
"Geology," with 20 coloured plates, by Jukes; "Geology,"  
by Phillips; "The Microscope," by Hogg; "History of  
Birds," by Stanley; "Nests and Eggs of North American  
Birds," by Davie; "Science Sitings," vols. i. and ii., bound.  
Wanted, British birds' eggs in clutches, side-blown, with  
full data.—Edward Kitchen, 116, Eversleigh Road, Battersea,  
S.W.

MOSSES, ferns, shells (British and foreign), correctly  
named; living plants of Killarney fern (*Trichomanes radi-  
cans*) offered for foreign land shells not in collection.—T.  
Rogers, 27, Oldham Road, Manchester.



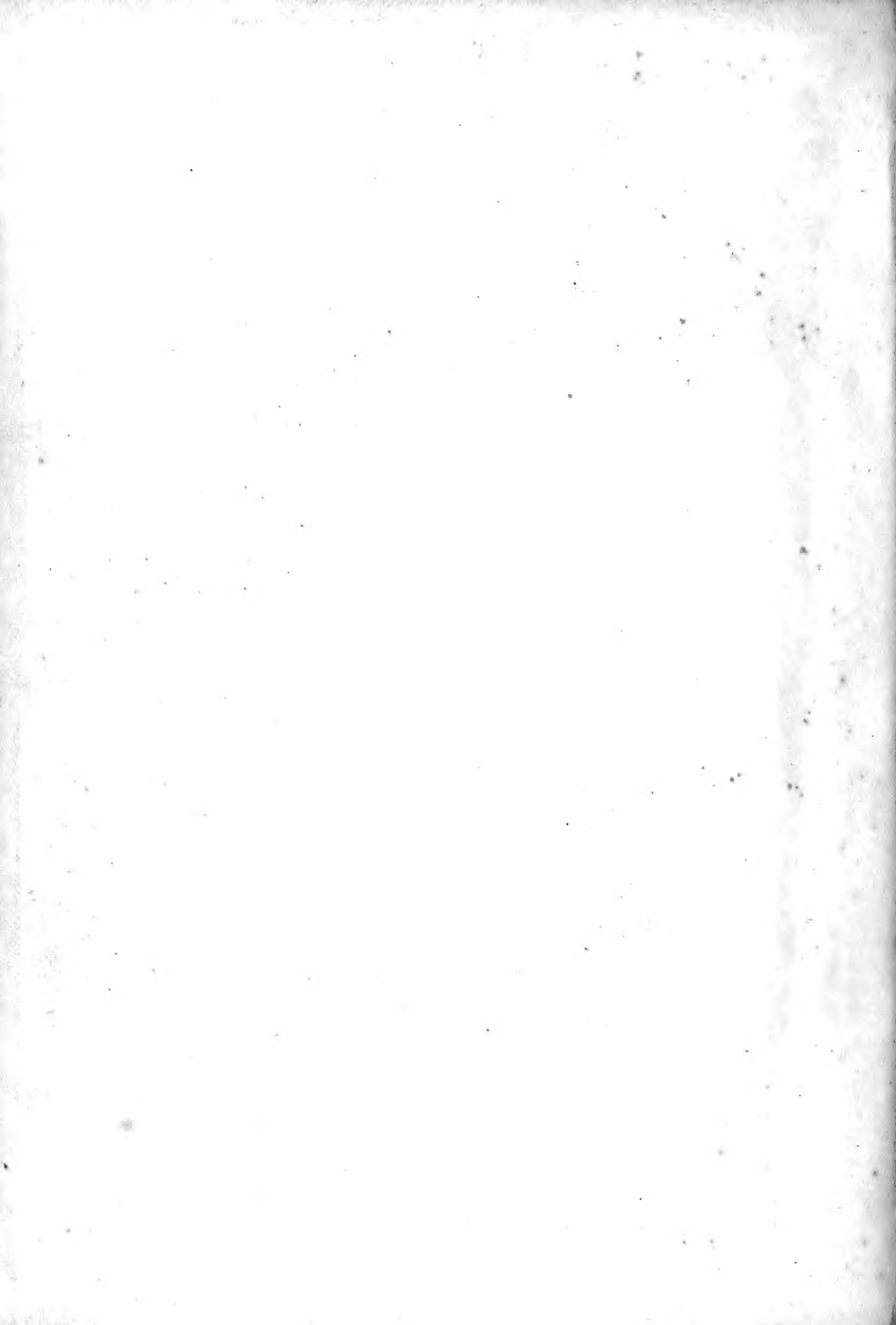



1898

650

21 1000

98

10

38

AMNH LIBRARY



100167228