



In. L. Jery. From.

Mr. Fred. W. Primrose

Thorby.  
Aundel Road.  
Eastbourne.

RB59213



Library  
of the  
University of Toronto









NATURAL SCIENCE

*By the same Author.*

**Winners in Life's Race; or, the Great Backboned Family.**

Crown 8vo, with numerous Illustrations, cloth gilt, gilt edges, 8s 6d.  
calf, 14s.

**Life and Her Children.**

Eighth Thousand, Cloth 6s. ; Calf, 11s.

**The Fairy-Land of Science.**

Fourteenth Thousand, Cloth, 6s. ; Calf, 11s.

**Botanical Tables for the Use of Junior Students.**

New and Revised Edition, folded in Cloth Cover, 1s. 6d.

---

LONDON: EDWARD STANFORD, 55 CHARING CROSS, S. W.



A SHORT HISTORY  
OF  
NATURAL SCIENCE

AND OF THE  
Progress of Discovery from the Time of the Greeks  
to the Present Day

*FOR THE USE OF SCHOOLS AND YOUNG PERSONS*

By ARABELLA B. BUCKLEY

AUTHOR OF 'THE FAIRY-LAND OF SCIENCE;' 'LIFE AND HER CHILDREN;'  
'WINNERS IN LIFE'S RACE;' AND 'BOTANICAL TABLES'

THIRD EDITION

WITH CORRECTIONS AND ADDITIONS

LONDON  
EDWARD STANFORD, 55 CHARING CROSS, S.W.

1883

*Printed by* EDWARD STANFORD, 55 *Charing Cross, London, S.W.*

*DEDICATION TO THE FIRST EDITION*

To the Memory of

MY BELOVED AND REVERED FRIENDS

SIR CHARLES AND LADY LYELL

TO WHOM I OWE MORE THAN I CAN EVER EXPRESS

I Dedicate this my First Book

TRUSTING THAT IT MAY HELP

TO DEVELOP IN THOSE WHO READ IT THAT  
EARNEST AND TRUTH-SEEKING SPIRIT IN THE STUDY OF  
GOD'S WORKS AND LAWS WHICH WAS THE  
GUIDING PRINCIPLE OF  
THEIR LIVES

## NOTE TO THIRD EDITION,



THE only important change in this Edition has been the recasting of the final chapter, to bring certain points up to date. The whole work has, however, been carefully revised and corrected, especially with reference to the terms necessitated by modern theories of electro-magnetism.

LONDON, 1883.

## PREFACE TO SECOND EDITION.



IN the present Edition I have endeavoured to supply many important omissions, especially as regards "Sound," which had been before entirely neglected, and to which a new chapter (XXX.) is now devoted. I have also added some new matter in the thirty-eighth chapter upon the Botany of the Nineteenth Century, though I regret that even now the account of the progress of Biology is necessarily very imperfect owing to the small space which could be allotted to it. Lastly, besides many minor additions, I have given, in a new concluding chapter, a brief sketch of some of the latest advances in Science.

I wish to acknowledge gratefully many useful suggestions and corrections given by my critics, and also the assistance rendered me by those eminent scientific men who have been so good as to read the proof-sheets referring to their special subjects. The work will, I trust, be now free from important errors ;

and, as I have also taken special care to amend ambiguities of language and other small blemishes which have been pointed out, or which have been discovered by a careful revision, I venture to hope that this Second Edition will fully justify the kind reception accorded to the book when it first appeared.

LONDON, *October* 1879.

## PREFACE TO FIRST EDITION.



IT is not without some anxiety that I offer this little work to the public, for it is, I believe, the first attempt which has been made to treat the difficult subject of the History of Science in a short and simple way.<sup>1</sup>

Its object is to place before young and unscientific people those main discoveries of science which ought to be known by every educated person, and at the same time to impart a living interest to the whole, by associating with each step in advance some history of the men who made it.

During the many years that I enjoyed the privilege of acting as secretary to the late Sir Charles Lyell, and was thus brought in contact with many of the leading scientific men of our day, I often felt very forcibly how many important facts and generalisations of science, which are of great value both in the formation of character and in giving a true estimate of life and its conditions, are totally unknown to the majority of otherwise well-educated persons.

Great efforts are now being made to meet this difficulty,

<sup>1</sup> Mr. Baden Powell's excellent little 'History of Natural Philosophy,' published in Lardner's 'Cyclopædia' in 1834, is scarcely intended for beginners, and does not extend farther than the seventeenth century. This is the only work of the kind I have been able to find.

by teaching children a few elementary facts of the various branches of science; but, though such instruction is of immense value, something more is required in order that the mind may be prepared to follow intelligently the great movement of modern thought. The leading principles of science ought in some measure to be understood; and these will, I believe, be most easily and effectually taught by showing the steps by which each science has attained its present importance.

It is this task which I have endeavoured to accomplish; and if teachers will make their pupils master the explanations given in these pages and, wherever it is possible, try the experiments suggested, I venture to hope that this little work may supply that modest amount of scientific information which every one ought to possess, while, at the same time, it will form a useful groundwork for those who wish afterwards to study any special branch of science.

The plan adopted has been to speak of discoveries in their historical order, and to endeavour to give such a description of each as can be understood by any person of ordinary intelligence. This has made it necessary to select among subjects of equal importance those which could be dealt with in plain language, and to avoid passing allusions to such as did not admit of such explanation.

The history of the nineteenth century has been a very difficult and I fear scarcely a successful task; for, while those who know anything of the subjects mentioned will feel that the account is very defective owing to so much being left out, the beginner will probably find it difficult



---

owing to so much being put in. The reproach on both sides would be just, yet it seemed better to give even a few of the leading discoveries and theories of our own time than to leave the student with such crude ideas of many branches of science as he must have had if the history had ended with the eighteenth century.

When treating of such varied subjects, many of them presenting great difficulties both as regards historical and scientific accuracy, I cannot expect to have succeeded equally in all, and must trust to the hope of a future edition to correct such grave errors as will doubtless be pointed out, in spite of the care with which I have endeavoured to verify the statements made.

As the size of the book makes it impossible to give the numerous references which would occur on every page, I have named at the end of each chapter a few of the works consulted in its preparation, choosing always in preference those which will be useful to the reader if he cares to refer to them. I had also prepared questions on the work; but those competent to give an opinion, tell me that teachers in these days prefer to prepare their own lessons. I have therefore substituted, at p. 481, a chronological table of the various sciences, by means of which questions can be framed, either upon the discoveries of any given period, or on the progressive advance, through several centuries, of any of the five main divisions of science which are dealt with in this volume.

In conclusion, I wish to acknowledge my obligations to many kind friends, and especially to Mr. A. R. Wallace

and Mr. J. C. Moore, F.R.S., who have rendered me very material and valuable assistance. I am also much indebted to the Rev. R. M. Luckock, of the Godolphin Grammar School, who read the whole work in manuscript, with a view to pointing out any portions which might be unintelligible to schoolboys.

LONDON, *December* 1875.

---

*To the Binder.*

The Coloured Plate of Spectra to face p. 330.

# CONTENTS.



INTRODUCTION. . . . .	PAGE I
-----------------------	-----------

## PART I.

### *SCIENCE OF THE GREEKS.*

#### CHAPTER I.

639 TO 470 B.C.

Ignorance of the Greeks concerning Nature—Ionian School of Learning—Thales discovers the Solstices and Equinoxes, and knows that the Moon Reflects the Light of the Sun—Anaximander invents a Sun-dial—Discovers the Phases of the Moon—Makes a Map of the Ancient World—Pythagoras teaches that the Earth moves, and that the Morning and Evening Star are the same—He studies Geology, and knows that Land has in some places become Sea—True sayings of Pythagoras and his Followers about Geology—Invention of the Monochord . 7

#### CHAPTER II.

499 TO 322 B.C.

Anaxagoras studies the Moon—Describes Eclipses of the Sun and Moon—Is Tried and Condemned for Denying that the Sun is a God—Hippocrates the Father of Medicine—Separates the office of Priest and Doctor—Studies the Human Body—Eudoxus has an Observatory—Makes a Map of the Stars—Explains the Movements of the Planets—Democritus studies the Milky Way—Aristotle an Astronomer and Zoologist—Divides Animals into Classes—Teaches that there is a Gradual Succession of Animal Life—Studies the Difference of the Life in Plants and Animals—Theophrastus the first Botanist . 13

## CHAPTER III.

320 TO 212 B.C.

	PAGE
School of Science at Alexandria—The Ecliptic and the Zodiac— Greeks believed that the Sun moved round the Earth—Aristarchus knew that it was the Earth which moved—He also knew of the Obliquity of the Ecliptic, and that the Seasons are caused by it—He knew that the Earth turns daily on its Axis—Euclid discovers that Light travels in straight lines—Archimedes discovers the Lever—Principle of the Lever—Hiero's Crown, and how Archimedes discovered the principle of Specific Gravity—Screw of Archimedes . . . . .	18

## CHAPTER IV.

280 TO 120 B.C.

Erasistratus and Herophilus study the Human Body—Eratosthenes the Geographer lays down the First Parallel of Latitude and the First Meridian of Longitude—He measures the circumference of the Earth—Hipparchus writes on Astronomy—Catalogues 1080 Stars—Calculates when Eclipses will take place—Discovers the Precession of the Equinoxes . . . . .	26
--	----

## CHAPTER V.

FROM A.D. 70 TO 200.

Ptolemy founds the Ptolemaic System—He writes on Geography—Strabo, a great traveller, writes on Geography—Studies Earthquakes and Volcanoes—Pliny the Naturalist—Galen the greatest Physician of Antiquity—Describes the two Sets of Nerves—Proves that Arteries contain Blood—Lays down a theory of Medicine—Greece and her Colonies conquered by Rome—Decay of Science in Greece—Concluding remarks on Greek Science . . . . .	32
--	----

## PART II.

## SCIENCE OF THE MIDDLE AGES.

## CHAPTER VI.

## SCIENCE OF THE ARABS.

	PAGE
Dark Ages of Europe—The Arabs, checked in their conquests by Charles Martel, settle down to Science—The Nestorians and Jews translate Greek Works on Science—Universities of the Arabs—Chemistry first studied by the Arabs—Alchemy, or the attempt to make Gold—Hermes the first Alchemist—Hermetically-sealed Tubes—Gases and Vapours called ‘Spirits’ by the Arabs . . . . .	39

## CHAPTER VII.

## SCIENCE OF THE ARABS (CONTINUED).

Geber, or Djafer, the founder of Chemistry—His Explanation of Distillation—Of Sublimation—Discovers that some Metals increase in weight when heated—Discovers strong Acids—Nitric Acid—Sulphuric Acid—Discovery of Sal-Ammoniac by the Arabs—Arabs mix up Astronomy with Astrology—Albategnius calculates the Length of the Year—Mohammed Ben Musa, first writer on Algebra—Uses the Indian Numerals—Gerbert introduces them into Europe—Alhazen’s discoveries in Optics—His Explanation why only one image of each object reaches the Brain—His discovery of Refraction, and of its effect on the light of the Sun, Moon, and Stars—His discovery of the magnifying power of rounded glasses . . . . .	43
---	----

## CHAPTER VIII.

## SCIENCE OF THE MIDDLE AGES IN EUROPE.

Roger Bacon—His ‘Opus Majus’—His Explanation of the Rainbow—He makes Gunpowder—Studies Gases—Proves a Candle will not burn without Air—His Description of a Telescope—
--

	PAGE
Speaks of Ships going without Sails—Flavio Gioja invents the Mariner's Compass—Greeks knew of the Power of the Loadstone to attract Iron—Use of the Compass in discovering new lands—Invention of Printing—Columbus discovers America—Vasco de Gama sees the Stars of the Southern Hemisphere—Magellan's ship sails round the World—Inventions of Leonardo da Vinci . . . . .	51

---

### PART III.

#### *RISE AND PROGRESS OF MODERN SCIENCE.*

#### CHAPTER IX.

##### SCIENCE OF THE SIXTEENTH CENTURY.

Rise of Modern Science—Dogmatism of the Middle Ages—Reasons for studying discoveries in the order of their dates—Copernican theory of the Universe—Copernicus goes back to the System of Aristarchus—Is afraid to publish his Work till quite the end of his Life—Work of Vesalius on Anatomy—He shows that Galen made many mistakes in describing Man's Structure—His Banishment and Death—The value of his Work to Science—Fallopian and Eustachian Anatomists—Gesner's Works on Animals and Plants—He forms a Zoological Cabinet and makes a Botanical Garden—His Natural History of Animals—His classification of Plants according to their Seeds—His work on Mineralogy—Cæsalpinus makes the First System of Plants on Gesner's plan—Explains Dioecious Plants—Chemistry of Paracelsus and Van Helmont . . . . .	61
---	----

#### CHAPTER X.

##### SCIENCE OF THE SIXTEENTH CENTURY (CONTINUED)

Baptiste Porta discovers the Camera Obscura—Shows that our Eye is like a Camera Obscura—Makes a kind of Magic Lantern by Sunlight—Kircher afterwards makes a Magic Lantern by Lamplight—Dr. Gilbert's discoveries in Electricity—Tycho
--

	PAGE
Brahe, the Danish Astronomer—Builds an Observatory on the Island of Huen—Makes a great number of Observations, and draws up the Rudolphine Tables—Galileo discovers the principle of the Pendulum—Calculates the velocity of Falling Bodies, and shows why it increases—Shows that Unequal Weights fall to the Ground in the same time—Establishes the relations of Force and Weight—Studies musical Sounds—Stevinus on Statics—Summary of the Science of the sixteenth century . . . . .	72

CHAPTER XI.

SCIENCE OF THE SEVENTEENTH CENTURY.

Astronomical discoveries of Galileo—The Telescope—Galileo examines the Moon, and discovers the Earth-light upon it—Discovers Jupiter's four Moons—Distinguishes the Fixed Stars from the Planets—The phases of Venus confirm the Copernican theory—Galileo notices Saturn's Ring, but does not distinguish it clearly—Observes the spots on the Sun—The Inquisition force him to deny the movement of the Earth—Blindness and Death of Galileo . . . . .	85
--	----

CHAPTER XII.

SCIENCE OF THE SEVENTEENTH CENTURY (CONTINUED).

Kepler the German Astronomer—Succeeds Tycho as Mathematician to the Emperor Rudolph—His description of the Eye—He tries to explain the orbit of the planet Mars—And by comparing Tycho's tables with observation discovers his First and Second Law of the movements of the Planets—His delight at Galileo's discoveries—Kepler's Third Law—Comparison of the labours of Tycho, Galileo, and Kepler . . . . .	93
---	----

## CHAPTER XIII.

## SCIENCE OF THE SEVENTEENTH CENTURY (CONTINUED).

	PAGE
Francis Bacon, 1561-1626—He teaches the true method of studying Science in his 'Novum Organum'—René Descartes, 1596-1650—He teaches that Doubt is more honest than Ignorant Assertion—Willebrord Snellius discovers the Law of Refraction, 1621—Explanation of this Law . . . . .	101

## CHAPTER XIV.

## SCIENCE OF THE SEVENTEENTH CENTURY (CONTINUED).

Fabricius Aquapendente discovers Valves in the Veins—Harvey's discovery of the Circulation of the Blood—Discovery of the Vessels which carry nourishment to the Blood—Gaspard Asellius notices the Lacteals—Pecquet discovers the Passage of the fluid to the Heart—Rüdbeck discovers the Lymphatics	108
--	-----

## CHAPTER XV.

## SCIENCE OF THE SEVENTEENTH CENTURY (CONTINUED).

Toricelli discovers the reason of Water rising in a Pump—Uses Mercury to measure the Weight of the Atmosphere—Makes the First Barometer—M. Perrier, at Pascal's suggestion, demonstrates variations in the pressure of the atmosphere—Otto Guericke invents the Air-pump—Working of the Air-pump—Guericke proves the Pressure of the Atmosphere by the experiment of the Magdeburg Spheres—He makes the first Electrical Machine—Foundation of Royal Society of London and other Academies of Science . . . . .	114
---	-----

## CHAPTER XVI.

## SCIENCE OF THE SEVENTEENTH CENTURY (CONTINUED).

Boyle's Law of the Compressibility of Gases—This same Law discovered independently by Marriotte—Hooke's theory of Air	
---	--



	PAGE
being the cause of Fire—Boyle's experiments with Animals under the Air-pump—John Mayow, the greatest Chemist of the Seventeenth Century—His experiments upon the Air used in Combustion—Proves that the same portion is used in Respiration—Proves that Air which has lost its Fire-air is Lighter—Mayow's 'Fire-air' was Oxygen, and his Lighter Air Nitrogen—He traces out the effect which Fire-air produces in Animals when Breathing . . . . .	126

CHAPTER XVII.

SCIENCE OF THE SEVENTEENTH CENTURY (CONTINUED).

Malpighi first uses the Microscope to examine Living Structures—He describes the Air-cells of the Lungs—Watches the Circulation of the Blood—Observes the Malpighian Layer in the Human Skin—Describes the Structure of the Silkworm—Leeuwenhoeck discovers Animalcules—Grew and Malpighi discover the Cellular Structure of Plants—The Stomates in Leaves—They study the Germination of Seeds—Ray and Willughby classify and describe Animals and Plants—The Friendship of these two Men . . . . .	134
---	-----

CHAPTER XVIII.

SCIENCE OF THE SEVENTEENTH CENTURY (CONTINUED).

42, Birth of Newton—His Education—1666, His three great Discoveries first occur to him—Method of Fluxions and Differential Calculus—First thought of the Theory of Gravitation—Failure of his Results in Consequence of the Faulty Measurement of the size of the Earth—1682, Hears of Picart's new Measurement—Works out the result correctly, and proves the Theory of Gravitation—Explanation of this Theory—Establishes the Law that Attraction varies inversely as the squares of the distance—Explains the transmission of sound—1687, Publishes the 'Principia'—Some of the Problems dealt with in this Work . . . . .	144
---	-----

## CHAPTER XIX.

## SCIENCE OF THE SEVENTEENTH CENTURY (CONTINUED).

	PAGE
Transits of Mercury and Venus—Kepler foretells their occurrence—1631, Gassendi observes a transit of Mercury—1639, Horrocks foretells and observes a Transit of Venus—1676, Halley sees a Transit of Mercury, and it suggests to him a method for Measuring the Distance of the Sun—1691-1716, Halley describes this method to the Royal Society—Explanation of Halley's method . . . . .	153

## CHAPTER XX.

## SCIENCE OF THE SEVENTEENTH CENTURY (CONTINUED).

Newton's Discovery of the Dispersion of Light—Traces the amount of Refraction of each of the Coloured Rays—Makes a Rotating Disc turning the colours of the Spectrum into White Light—Reason why all Light passing through glass is not Coloured—Mr. Chester More Hall discovers the Difference of Dispersive Power in Flint and Crown Glass—Newton's Papers destroyed by his pet dog—Last years of Newton's life . . . . .	161
---	-----

## CHAPTER XXI.

## SCIENCE OF THE SEVENTEENTH CENTURY (CONTINUED).

Roemer measures the Velocity of Light—Newton's Corpuscular Theory of Light—Undulatory or Wave Theory proposed by Huyghens—Invention of Cycloidal Pendulums by Huyghens—Discovery of Saturn's Ring—Sound caused by Vibration of Air—Light by Vibration of Ether—Reasons why we see Light—Reflection of Waves of Light—Cause of Colour—Refraction explained by the Undulatory Theory—Mr. Tylor's Illustration of Refraction—Double Refraction explained by Huyghens—Polarization of Light not understood till the nineteenth century . . . . .	172
--	-----

## CHAPTER XXII.

	PAGE
SUMMARY OF THE SCIENCE OF THE SEVENTEENTH CENTURY .	182

## CHAPTER XXIII.

## SCIENCE OF THE EIGHTEENTH CENTURY.

Great spread of Science in the Eighteenth Century—Advance of the Sciences relating to Living Beings—Foundation of Leyden University in 1574—Boerhaave, Professor of Medicine at Leyden, 1701—Foundation of Chemistry of organic compounds by Boerhaave—Influence of Boerhaave upon the study of Medicine—Belief of the Alchemists in ‘Vital Fluids’—Boerhaave’s Experiments on the Juices of Plants—Dr. Hales’s Experiments on Plants—Boerhaave’s Analyses of Milk, Blood, etc.—Great popularity of his Chemical Lectures . . . . .	189
---	-----

## CHAPTER XXIV.

## SCIENCE OF THE EIGHTEENTH CENTURY (CONTINUED).

Childhood of Haller—Foundation of the University of Göttingen in 1736—Haller made Professor of Anatomy—Haller’s Anatomical Plates—He discovers the power of Contraction of the Muscles—Rise of Comparative Anatomy—John Hunter’s industry in Dissecting and Comparing the Structures of different Animals—His Museum and the arrangement of his Collection—Bonnet’s Experiments on Plants—Experiments upon Animals by Bonnet and Spallanzani—Regrowth of different parts when cut off—Bonnet’s theory of Gradual Development of Plants and Animals—Anatomical Works of Haller—He discovers the power of the Muscles to contract . . . . .	195
---	-----

## CHAPTER XXV.

## SCIENCE OF THE EIGHTEENTH CENTURY (CONTINUED).

	PAGE
Birth and Early Life of Buffon and Linnæus compared—Buffon's Work on Natural History—Daubenton wrote the Anatomical Part—Buffon's Books very interesting, but not always accurate—He first worked out the Distribution of Animals—Struggles of Linnæus with Poverty—Mr. Clifford befriends him—He becomes Professor at Upsala—He was the first to give Specific Names to Animals and Plants—Explanation of his Descriptions of Plants—Use of the Linnæan or Artificial System—Afterwards superseded by the Natural System—Linnæus first used accurate terms in describing Plants and Animals—Character of Linnæus—Sale of his Collection, and Chase by the Swedish Man-of-war . . . . .	203

## CHAPTER XXVI.

## SCIENCE OF THE EIGHTEENTH CENTURY (CONTINUED).

The Study of the Earth neglected during the Dark Ages—Prejudices concerning the Creation of the World—Attempts to Account for Buried Fossils—Palissy, the Potter, first asserted that Fossil-shells were real Shells—Scilla's Work on the Shells of Calabria, 1670—Woodward's Description of Different Formations, 1695—Lazzaro Moro one of the first to give a true explanation of the facts—Abraham Werner lectures on Mineralogy and Geology, 1775—Disputes between the Neptunists and Vulcanists—Dr. Hutton first teaches that it is by the Study of the Present that we can understand the Past—Theory of Hutton—Sir J. Hall's Experiments upon Melted Rocks—Hutton discovers Granite Veins in Glen Tilt—William Smith, the 'Father of English Geologists'—His Geological Map of England . . . . .	213
---	-----

CHAPTER XXVII.

SCIENCE OF THE EIGHTEENTH CENTURY (CONTINUED).

	PAGE
Birth of Modern Chemistry—Discovery of ‘Fixed Air,’ or Carbonic Acid, by Black and Bergmann—Working out of ‘Chemical Affinity’ by Bergmann—He tests Mineral Waters, and proves ‘Fixed Air’ to be an Acid—Discovery of Hydrogen by Cavendish—He investigates the Composition of Water—Oxygen discovered by Priestley and Scheele—Priestley’s Experiments—He fails to see the true bearing of his Discovery—His Political Troubles and Death—Nitrogen described by Dr. Rutherford—Lavoisier lays the Foundation of Modern Chemistry—He destroys the Theory of ‘Phlogiston’ by proving that Combustion and Respiration take up a Gas out of the Air—Discovers the Composition of Carbonic Acid and the nature of the Diamond—French School of Chemistry—Death of Lavoisier . . . . .	224

CHAPTER XXVIII.

SCIENCE OF THE EIGHTEENTH CENTURY (CONTINUED).

Doctrine of Latent Heat, taught by Dr. Black in 1760—Water containing Ice remains always at 0° C., and Boiling Water at 100° C., however much Heat is added—Black showed that the lost Heat is absorbed in altering the condition of the Water—Watt’s Application of the Theory of Latent Heat to the Steam-engine—Early History of Steam-engines—Newcomen’s Engine—Watt invents the Separate Condenser—Diagram of Watt’s Engine—Difficulties of Watt and Boulton in introducing Steam-engines . . . . .	240
--	-----

CHAPTER XXIX.

SCIENCE OF THE EIGHTEENTH CENTURY (CONTINUED).

Benjamin Franklin born, 1706—His Early Life—Du Faye discovers two kinds of Electricity—Franklin proves that Electricity exists in all Bodies, and is only developed by Friction

	PAGE
—Positive and Negative Electricity—Franklin draws down Electricity from the Sky—Invents Lightning-conductors—Discovery of Animal Electricity by Galvani—Controversy between Galvani and Volta—Volta proves that Electricity can be produced by the Contact of two Metals—Electrical Batteries—The Crown of Cups—The Voltaic Pile . . . . .	252

### CHAPTER XXX.

#### SCIENCE OF THE EIGHTEENTH CENTURY (CONTINUED).

Calculation of musical Vibrations, Sauveur—Experiments on Vibrations of Strings—Bernoulli, Euler, Lagrange—Four Conditions determining the pitch of a Stretched String—The Octave—Nodes and Segments in a Vibrating String—Over-tones or Harmonics—Chladni—Discovers Mode of Vibration of Metal and Glass Plates—Vibration of Bells and Gongs—Sand Figures produced by Vibration . . . . .	263
--	-----

### CHAPTER XXXI.

#### SCIENCE OF THE EIGHTEENTH CENTURY (CONTINUED).

Bradley and Delisle, Astronomers—Aberration of the Fixed Stars—Nutation of the Axis of the Earth, Delisle's Method of Measuring the Transit of Venus—Lagrange and Laplace—Libration of the Moon accounted for by Lagrange—Laplace works out the Long Inequality of Jupiter and Saturn—Lagrange proves the Stability of the Orbits of the Planets—Sir William Herschel constructs his own Telescopes—Discovery of a New Planet—Discovery of Binary Stars—Herschel studies Star-clusters and Nebulæ—Theory of Nebulæ being matter out of which Stars are made—The Motion of our Solar System through Space—Weight of the Earth determined by the Schehallion Experiment—Summary of the Science of the Eighteenth Century . . . . .	275
--	-----

## CHAPTER XXXII.

## SCIENCE OF THE NINETEENTH CENTURY.

PAGE

Difficulties of Contemporary History—Discovery of Asteroids and Minor Planets between Mars and Jupiter—Dr. Olbers suggests they may be fragments of a larger Planet—Encke's Comet, and the correction of the size of Jupiter and Mercury—Biela's Comet, noticed in 1826—It divides into two Comets in 1845—Irregular movements of Uranus—Adams and Leverrier calculate the position of an Unknown Planet—Neptune found by these calculations in 1846—A Survey of the whole Heavens made by Sir John Herschel—His work in Astronomy—Comets and Meteor-systems . . . . .	297
--	-----

## CHAPTER XXXIII.

## SCIENCE OF THE NINETEENTH CENTURY (CONTINUED).

Discoveries concerning Light made in the Nineteenth Century—Birth and History of Dr. Young—He explains the Interference of Light—Cause of Prismatic Colours in a Shadow—And in a Soap-bubble—Malus discovers the Polarization of Light caused by Reflection—Birth and History of Fresnel—Polarization of Light explained by Young and Fresnel—Complex Vibrations of a Ray of Light—How these Waves are reduced to two separate Planes in passing through Iceland-spar—Sir David Brewster and M. Biot explain the colours produced by Polarization—Fizeau and Foucault on Velocity of Light . . . . .	311
--	-----

## CHAPTER XXXIV.

## SCIENCE OF THE NINETEENTH CENTURY (CONTINUED).

History of Spectrum Analysis—Discovery of Heat-rays by Sir W. Herschel—And of Chemical Rays by Ritter of Jena—Photography first suggested by Davy and Wedgwood—Carried out by Daguerre and Talbot—Dark Lines in the Spectrum first	
--	--

	PAGE
observed by Wollaston—Mapped by Fraunhofer—Life of Fraunhofer—He discovers that the Dark Lines are different in Sun-light and Star-light—Experiments on the Spectra of different Flames—Four new Metals discovered by Spectrum Analysis—Artificial Dark Lines produced in the Spectrum by Sir David Brewster—Bunsen and Kirchhoff explain the Dark Lines in the Solar Spectrum—Metals in the Atmosphere of the Sun—Photosphere—Corona—Janssen and Lockyer on Red Prominences—Chromosphere—Huggins and Miller examine the Stars and Nebulæ by Spectrum Analysis . . .	325

## CHAPTER XXXV.

### SCIENCE OF THE NINETEENTH CENTURY (CONTINUED).

Early Theories about Heat—Count Rumford shows that Heat can be produced by Friction—He makes Water boil by boring a Cannon—Davy makes two pieces of Ice melt by Friction—His conclusion about Heat—How ‘Latent Heat’ is explained on the theory that Heat is a kind of Motion—Dr. Mayer suggests the Determination of the Mechanical Equivalent of Heat—Dr. Joule’s Experiments on the Mechanical Equivalent of Heat—Dr. Hirn’s Experiments on the conversion of Heat into Motion—Proof of the Indestructibility and Conservation of Energy—Theory of dissipation of Energy . . .	341
---	-----

## CHAPTER XXXVI.

### SCIENCE OF THE NINETEENTH CENTURY (CONTINUED).

Oersted discovers the effect of Electricity upon a Magnet—Electro-Magnetism—Experiments by Ampère on Magnetism and Electricity—Ampère’s Early Life—Direction of the North Pole of the Magnet depends on the course of the Electric Currents—Lines of Magnetic Force between two Electric Wires—Electro-Magnets made by means of an Electric Current—Arago magnetises a Steel Bar with an ordinary Electrical Machine—Faraday discovers the Rotatory Movement of Magnets and Electrified Wires—Produces an	
---	--



	PAGE
Electric Current by means of a Magnet—Seebeck discovers Thermo-Electricity, or the production of Electricity by Heat—Schwabe discovers Periodicity of the Spots on the Sun—Sabine suggests a connection between Sun-spots and Magnetic phenomena—This proved in 1859 by Observations of Carrington and Hodgson—Electric Telegraph—Wheatstone—Cooke—Steinheil—Morse—Bain—Cowper's Telegraph—The Telephone . . . . .	355

## CHAPTER XXXVII.

## SCIENCE OF THE NINETEENTH CENTURY (CONTINUED).

Davy discovers that Nitrous Oxide produces Insensibility—Laughing-gas—Safety-lamp, 1815—Nicholson and Carlisle discover Decomposition of Water, 1800—Davy discovers the effect of Electricity upon Chemical Affinity—Faraday's Discoveries in Electrolysis—Indestructibility of Force—Various Modes discovered of Decomposing Substances—John Dalton, chemist—Law of Definite Proportions—Law of Multiple Proportions—Dalton's Atomic Theory—The Study of Organic Chemistry—Liebig, the great teacher in Organic Chemistry . . . . .	378
--	-----

## CHAPTER XXXVIII.

## SCIENCE OF THE NINETEENTH CENTURY (CONTINUED).

The Organic Sciences are too difficult to follow out in detail—Jussieu's Natural System of Plants—Sprengel on fertilisation of Plants by insects—Robert Brown on embryological botany—Sir W. Hooker—Goethe proves the Metamorphosis of Plants . . . . .	396
---	-----

## CHAPTER XXXIX.

## SCIENCE OF THE NINETEENTH CENTURY (CONTINUED).

Humboldt studies the Lines of Average Temperature on the Globe—Extends our knowledge of Physical Geography—Writes the	
---	--

	PAGE
‘Cosmos’—Death of Humboldt—The three Naturalists, Lamarck, Cuvier, and Geoffroy St.-Hilaire—Cuvier begins the Museum of Comparative Anatomy—Lamarck’s History of Invertebrate Animals—G. St.-Hilaire brings Natural History Collections from Egypt—Lamarck on the Development of Animals—G. St.-Hilaire on ‘Homology,’ or the similarity in the parts of different animals—Cuvier’s ‘Règne Animal’ and his Classification of Animals—Cuvier on the Perfect Agreement between the Different Parts of an animal—He Studies and Restores the Remains of Fossil Animals—His ‘Ossemens Fossiles’—Death of Cuvier—Von Baer on the Study of Embryology—Parker and Balfour on Embryology . . . . .	408

## CHAPTER XL.

### SCIENCE OF THE NINETEENTH CENTURY (CONTINUED).

Prejudices which retarded the study of Geology—Sir Charles Lyell traces out the Changes going on now—Mud carried down by the Ganges—Eating away of Sea-coasts—Eruption of Skaptar Jokul—Earthquake of Calabria—Rise and Fall of Land—‘Principles of Geology’ published in 1830—Murchison on stratigraphical geology—Louis Agassiz—De Saussure’s Study of Glaciers—Agassiz on Europe and North America being once covered with Ice—Boucher de Perthes on Ancient Flint Implements—M’Enery on Flint Implements in Kent’s Cavern, with Bones of Extinct Animals—Swiss Lake-dwellings—‘Antiquity of Man’ . . . . .	426
--	-----

## CHAPTER XLI.

### SCIENCE OF THE NINETEENTH CENTURY (CONTINUED).

Facts which led Naturalists to believe that the different kinds of Animals are descended from Common Ancestors—All Animals of each class formed on one Plan—Embryological Structure—Living and Fossil Animals of a country resemble each other—Gradual Succession of Animals on the Globe—Links between	
---	--

	PAGE
different species— Darwin's Theory of Natural Selection— Wallace worked out the same Theory independently—Sketch of the Theory of Natural Selection—Selection of Animals by Man—Selection by Natural Causes—Difficulties in Natural History which are explained by this Theory . . . . .	441

---

## CHAPTER XLII.

### A GLANCE AT RECENT ADVANCES IN SCIENCE.

Advantages now possessed by Students of Science—Improvements in Astronomical Instruments—Discovery of Satellites of Mars —Probable Discovery of Intramercurial Planets—Travelling stars studied by the Spectroscope—Leverrier's Analysis of the Orbits of the Major Planets—Molecular Theory of Gases— Researches of Sir W. Thomson and Clerk-Maxwell—Lique- faction of the Permanent Gases by Pictet and Cailletet— Crookes' Discovery of Ultra-gaseous State of Matter—The present state of Biological Science—Geographical distribution —Carnivorous Plants—Fertilisation of Plants—Foundation of new Zoological Classifications—Discoveries of Fossil Animals by Professor Marsh—Links thus afforded in the Animal Series—Concluding Remarks on the History of Science . . . . .	456
--	-----

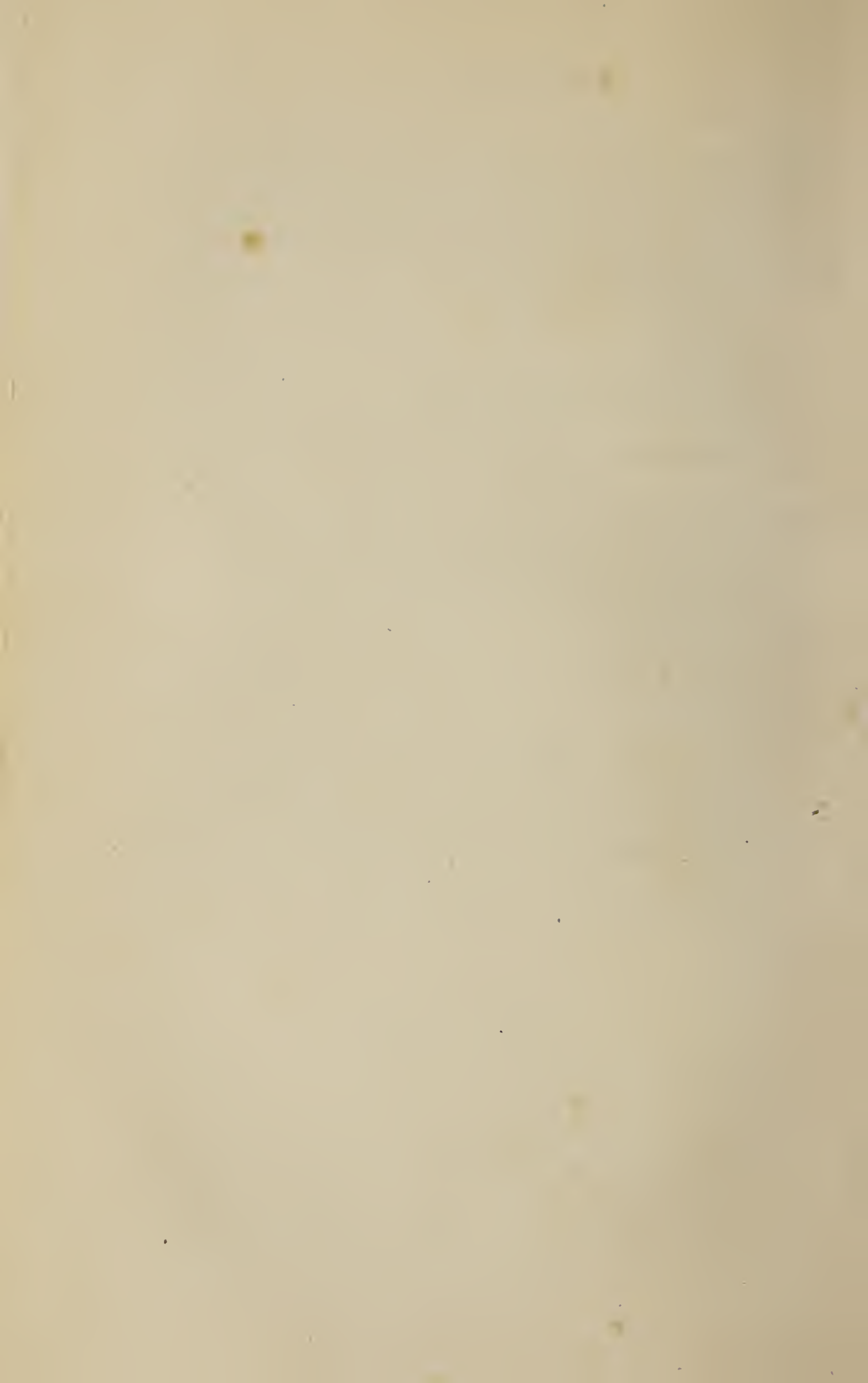

A SHORT HISTORY  
OF  
NATURAL SCIENCE.



INTRODUCTION.

As this little work is to be a history of Natural Science, it will be as well to begin by trying to understand what Science is.

The word itself comes from *scio*, I know, and means simply *knowledge*. The *science of botany* is therefore the knowledge of plants ; and the *science of astronomy*, the knowledge of the heavenly bodies.

But now comes the question, What kind of knowledge is required? You might be able to tell the names of all the plants in the world, and of all the stars in the sky, and yet have scarcely any real knowledge of botany or astronomy. You will easily understand this if we compare it with something you meet with in daily life. Suppose I took you into a large school and told you the names of all the children there ; even if you learnt these names by heart, you could not say you knew the children, or anything about them, beyond their names. One might be ill-tempered, another good-tempered ; one might have a home and a father and mother, another might be an orphan and homeless, and

you would find their mere names of no use to you if you wished to choose one of them to do any work, or to be your friend and companion. For this you would want to learn their character, their habits, and other real facts about them.

Now this last is just the kind of knowledge which is required in science. If, besides the name of a plant, you know its different parts, the shape of its leaves, the number of its seeds, and how they are arranged in the seed-vessel, the number of stamens or thread-like bodies in the middle of the flower, the number and colour of its petals or flower-leaves, and many other points like these, then you know something of *structural botany*. If you know, besides, how a plant takes up food, how it breathes, and how the sunlight acts upon the leaves and alters the juices of the plant, then you know something of the *life* of the plant, or *physiological botany*. If you know where the plant grows best, in what soil, in what climate, and in what countries, then you know something of *geographical botany*; and if your knowledge is accurate and carefully learnt it is real science.

By this you will see that science means not merely knowledge, but an accurate and clear knowledge about the things which we see around us in the universe. In the present day, people are beginning to teach children much more on these subjects than they did forty years ago, and every intelligent boy or girl probably knows that *Astronomy* is the science of the sun, stars, and planets; *Physics* and *Mechanics*, the sciences which teach the properties of bodies and their laws of motion; *Biology* the science of life; *Geology* the science of the earth, teaching us how the different rocks have been formed; and *Chemistry* the science which treats of the materials of which all substances are

---

made, and shows the changes which take place when two substances act upon one another so as to make a new substance.

There are many simple books written now to explain these sciences, and those who wish can read these books and study the examples and experiments given in them. They tell us what science *now is*, and the explanations given by the best men about the universe in which we live. But they do not tell us how science has *become* what it is, and it is this which I hope to tell you in the present book.

A man who wishes to understand a steam-engine can do so by going to an engineer and having each part explained to him ; but if he wishes to know the history of the steam-engine he must go back to the first one ever made, and study each new improvement as it arose. And so if we go back to the first attempts made by thoughtful men to understand nature, and then trace up step by step the knowledge gained from century to century, we shall have at least a more intelligent understanding of that which is taught us now. But if we have any true love of knowledge we shall gain far more than this ; for in studying the history of those grand and patient men who often spent their lives and made great sacrifices to understand the works of God, the merest child must feel how noble it is to long and strive after truth.

When we go back to very early ages we do not find that people understood much of what we now call science. So long as men were chiefly occupied in protecting themselves against other savage men and wild beasts, and had to struggle very hard to get food and clothing, they had very little time or wish to study nature. Still they learnt many things which were necessary for their life. They

learnt, for instance, at what times the sun rose and set, for upon this their day's work depended. They learnt how often the moon was full, so that they could see their way by moonlight; and they remarked very early the times when spring, summer, autumn, and winter came round, because the sowing of their seeds and the gathering of their fruits depended upon these seasons.

In this way we find that as far back as history goes men have always had some knowledge of the facts of nature; and those nations, like the Egyptians and Chinese, which long ago had become highly civilised, had learnt a very great deal, and must probably have known some things of which we are still ignorant.

There has been a great deal written about the science of the Chinese, Indians, and Egyptians, but I shall not tell you anything about them here, because their knowledge has had very little to do with the science which has come down to us, and it would besides be difficult to give you any real idea of what they knew without writing a book on the subject.

We will start, therefore, with the Greeks, at the time when they first began to try and explain some of the natural events which they saw taking place every day. This was about the year 700 B.C., when Thales, one of the seven wise men, was living, and you will see in the next chapter that even at this time, when Greece was famous for its learning, the people had still some very strange ideas about the working of the universe.



PART I.

SCIENCE OF THE GREEKS

FROM B.C. 639 TO A.D. 200.

*Chief Men of Science among the Greeks.*

	B.C.
Thales . . . .	Born about 640.
Anaximander . . . .	610.
Pythagoras . . . .	500.
Anaxagoras . . . .	499.
Democritus . . . .	459.
Hippocrates . . . .	420.
Eudoxus . . . .	406.
Aristotle . . . .	384.
Theophrastus . . . .	371.
Aristarchus . . . .	320.
Euclid . . . .	300.
Archimedes . . . .	287.
Erasistratus . . . .	?
Herophilus . . . .	?
Eratosthenes . . . .	276.
Hipparchus . . . .	160.
Strabo . . . .	50 to A.D. 18.
Ptolemy . . . .	. . . 100.
Galen . . . .	. . . 131.

## CHAPTER I.

639 TO 470 B.C.

Ignorance of the Greeks concerning Nature—Ionian School of Learning—Thales—Anaximander—Pythagoras—True Sayings of Pythagoras and his Followers about Geology.

ABOUT 600 years before Christ was born, the Greeks were the most learned people in Europe. They were naturally a handsome and clever race, and their young men were trained to be both good soldiers and good scholars. An English boy, if he could be carried back to those days, would find that the young Greeks could read, write, draw, and argue as well as himself, and probably that they could leap, wrestle, and run better than himself or any of his schoolfellows.

But on some points he would find that their ideas were very strange. If he spoke to them of the world as a round globe they would stare in astonishment, and tell him that such an idea was absurd, for everyone knew that the world was flat, with the sea flowing all round it. If he asked them, in his turn, about Mount Etna, they would surprise him by replying that the god Vulcan had his smithy underneath the mountain, where he was forging thunderbolts for Jove, and that Etna was the chimney of his forge. But if he spoke of the sun as a globe of light, they would turn away from him in horror as a wicked unbeliever in the gods, for who among the Greeks did not know that the sun was the god Helios,

who drove his chariot every day across the sky from east to west? In fact, the Greeks, though learned and brave, were quite ignorant of what we now call 'natural knowledge;' they did not know that the rising and setting of the sun, and the eruption of a volcano, are things which happen from natural causes; but everything which was not done by man, they thought was the work of invisible beings or gods.

It was not long, however, before some wise men began to think more deeply about these things. You will have read in Grecian history how the Greeks, after the taking of Troy, crossed over the Hellespont and founded colonies on the coast of Asia Minor; one of the largest of these colonies was called Ionia, and the Ionians became famous for their learning and wisdom.

**Thales, 640 B.C.**—Here Thales, one of the seven wise men of Greece, was born at Miletus, about 640 B.C. Thales travelled in Egypt, and learned many things from the Egyptians, and then returned to his own land and founded a school of learning. He was the first Greek who studied astronomy, and although, like his countrymen, he believed that the earth was flat and floated on the water, yet he made several great discoveries.

The Greeks had always divided their year into two parts only, summer and winter, but Thales discovered that there are four distinct divisions marked out by the sun. He noticed that in the middle of winter the sun, instead of passing overhead, reached at mid-day only a certain low point in the heavens, and then began to set again, so that the day was short and the night long. This went on for a few days, and because the sun stood at the same height every day, the name of winter *sol-stice*, or sun-standing, was afterwards given to these days in the middle of winter. Afterwards the sun began to rise a very little higher every

day, till in three months, when winter had passed away and the plants and trees began to bud, the sun took exactly twelve hours to pass across the sky from sunrise to sunset, so then the day was twelve hours long, and the night also twelve hours; this was called the spring *equi-nox*, or equal night, meaning that the day and night were of equal length. After this the sun still rose higher every day, and in three months more stood for some days nearly overhead at mid-day, thus making a long journey from sunrise to sunset, and causing the day to be long and the night short. This was the summer *solstice*. Then the sun began to rise less high every day, and in another three months there was again equal day and equal night—the autumn *equinox* had arrived. Finally, in another three months, the shortest day came round again, and the whole round began afresh. This was how Thales marked out the *solstices* and the *equinoxes*; we still call them by the same name as he did, and you may watch these changes of the sun in the sky for yourself.

Thales knew that the sun and stars were not gods, and thought they were made of some fiery substance; he knew, also, that the moon receives its light from the sun and reflects it like a looking-glass. He was very learned in mathematics, and framed several propositions now found in the ‘Elements of Euclid.’ He is also said to have foretold an eclipse, but this is probably not true, as it requires more knowledge than he is likely to have had.

**Anaximander of Miletus, 610 B.C.**, the friend of Thales, was the next Greek who made important discoveries in science. He invented a sun-dial, by making a flat metal plate with the hours of the day marked upon it in a certain order, so that a large pin, or *style* as it is called, standing in the middle of the plate, cast a shadow on the right hour whenever the sun shone upon it. You can

understand that as the sun is low down in the morning, and gradually passes overhead during the day, it will cause the pin to throw its shadow in different directions at different hours.

In this way Anaximander taught the Greeks to measure the time of day. He is also said to have been the first astronomer who understood why we see the bright face of the moon growing from a crescent to a full moon and then diminishing again. To know this he must also have known that the moon moves round the earth every month. You can imitate the changes of the moon if you take a round stone and hold it just above your head between you and the sun; you will then have its shady side towards you; pass it slowly round your head, you will find that you see first a bright edge appearing, then more and more of the bright side, till when the stone is on one side of your head and the sun the other, you will see the whole of one side of the stone reflecting the sun's light—this is a full moon. Pass it on slowly round, and you will see this bright side disappear gradually till you bring it back to its old position between you and the sun, when it will be again dark. This is what the moon does every month, producing what are called the *phases of the moon*. Anaximander also made a map of the world, or at least of as much of it as was known in his time.

**Pythagoras**, one of the most celebrated of the learned men of Greece, is the next who told us anything about science. The time and place of his birth are uncertain, but he lived between 566 and 470 B.C. He travelled in Egypt, and learnt much there, and afterwards settled at Tarentum, in Italy, where he founded the famous sect of the Pythagoreans. You will read of the opinions of Pythagoras in books of philosophy, but we are only concerned with what he taught about nature.

He was the first to assert that the earth is not fixed, but moves in the heavens; but he did not know that it moves round the sun. He also discovered that the evening and morning star are the same planet; the early Greeks called this planet Phosphorus, and it did not receive the name of Venus till some time afterwards.

Some of the most remarkable truths taught by Pythagoras were about *geology*, or the study of the earth. He noticed that seashells were sometimes to be found far inland imbedded in solid ground in a way that showed they were not brought there by man. Therefore, he argued that to bury *sea*-shells in the rocks, the sea must once have been there. He had also probably watched the sea eating away the cliffs on the shores of Italy, as you may see it doing now on the shores of Norfolk and Suffolk; and when he was in Egypt he must have seen the Nile carrying mud and laying it down at its mouth, or delta, to form new land. From all these and other observations he, and his pupils who followed him, drew some very true conclusions which are given in Ovid's *Metamorphoses*:—

1. Solid land has been converted into sea.
2. Sea has been changed into land. Marine shells lie far distant from the deep.
3. Valleys have been excavated by running water, and floods have washed down hills into the sea.
4. Islands have been joined to the mainland by the growth of deltas and new deposits, as in the case of Antissa joined to Lesbos, Pharos to Egypt, etc.
5. Peninsulas have been divided from the mainland and have become islands, as Leucadia: and according to tradition Sicily, the sea having carried away the isthmus.
6. Land has been submerged by earthquakes; the Grecian cities of Helice and Buris, for example, are to be seen under the sea, with their walls inclined.

7. There are streams which have a petrifying power, and convert the substances which they touch into marble.

8. Volcanic vents shift their position ; there was a time when Etna was not a burning mountain, and the time will come when it will cease to burn.

These, and other sentences of the same kind, show how carefully Pythagoras and his followers must have observed nature, for the changes that are going on upon the earth take place so very slowly that it is only by very careful comparison that we can prove they are happening at all. Pythagoras was the first man who was called a *philosopher*, or lover of wisdom. He made many discoveries about musical notes, and the manner in which the different musical intervals can be produced on a stretched string. He was the inventor of a very simple but useful instrument called the *monochord*, which consists of a sounding board and box on which a single string is stretched, and having a small loose piece of wood, called a bridge, which is placed under the wire to divide it into segments. Pythagoras found that when he placed this bridge so as to divide the wire into two parts, of which one was twice as long as the other, and then struck each part, the shorter length gave a note exactly an octave higher than the longer one. If, however, he divided the string so that the two-fifths were on one side and three-fifths on the other, then the notes were separated by an interval of a fifth. In this way, by marking a scale of divisions on the sounding board, the Greek musicians were able to produce a whole series of musical notes on one string.



## CHAPTER II.

499 TO 322 B.C.

Anaxagoras—Hippocrates—Eudoxus—Democritus—Aristotle.

**Anaxagoras**, who was the next great teacher after Pythagoras, was born in Ionia about 499 B.C., but he went when quite young to Athens. He loved to study nature for its own sake, and was once heard to say that he was born to contemplate the sun, moon, and heavens. Although there were no telescopes in those days, he managed to observe that there were mountains, plains, and valleys in the moon. He believed it to be a second earth, perhaps with living beings in it. He did not know, as we do now, that the moon has no atmosphere round it, such as living beings like ourselves require in order to breathe. He discovered that an eclipse of the sun is caused by the moon coming directly between the earth and the sun, and an eclipse of the moon by the earth coming between the moon and the sun. When the moon comes exactly between our earth and the sun, we see the moon's dark body pass over the sun, so as to *eclipse* or shut it out; and when our earth comes exactly between the moon and the sun we cut off the sun's light from the moon, and see our own shadow passing over the moon's face, and thus we eclipse the moon.

Anaxagoras knew that the planets Jupiter, Saturn, Venus, Mars, and Mercury move in the heavens, and that the stars

do not move. He believed that all the heavenly bodies were fiery stones; the sun he thought was a huge fiery stone as big as the Peloponnesus. He was the first scientific man who was persecuted for declaring boldly what he believed to be the truth. The Greeks were very angry with him for teaching that the sun was not a god; so he was tried at Athens, when quite an old man, and condemned to death. His friend Pericles pleaded for him, and the sentence was changed to a fine and banishment, and he retired to Lampsacus, where he went on teaching science and philosophy till his death.

Anaxagoras was the first Greek philosopher who taught that there must be one Great Intelligence ruling over the universe. So that the Greeks punished as an atheist the man who first taught them of a Supreme God. This example should teach us to be very careful how we condemn the opinions of others, for fear that we, like the Greeks, should think another wicked only because his thoughts are nobler than we can understand.

**Hippocrates, 420 B.C.**—While Anaxagoras was studying the heavens, another man, born about 420 B.C. in the little island of Cos, was studying men, and how to make their lives healthier and happier. Hippocrates, the Father of Medicine, belonged to a family of doctors and priests. The Greeks did not understand that illness comes to us because we do not know how to take care of our bodies. They thought that every illness was a punishment sent because one of their gods was angry, so when they were ill they sent a present to the temple of Æsculápius, the god of medicine, and then went to the priests of Æsculapius to cure them. The ancestors of Hippocrates were all priests of Æsculapius, but he separated himself from the priesthood and devoted his time to studying the human body,

and finding out the causes of disease. He studied the effect that heat and cold have upon us, and taught physicians to pay attention to the kind of food given to sick people, and especially to watch carefully in sickness for the critical point when the fever is at its height. He wrote many learned works on the human body, and you should remember his name as the Founder of the science of Medicine.

**Eudoxus, 406—Democritus, 459 B.C.**—The great astronomer after Anaxagoras was called Eudoxus. He was born about 406 B.C., at Cnidos, in Asia Minor, where he had an observatory, from which he could watch the heavens, and by this means he made a map of all the stars then known. He was the first Greek astronomer who explained how the planets Jupiter, etc., moved round in the heavens, and the time at which they would appear again exactly in the same place as before. The great philosopher Democritus, of Abdera (459 B.C.), who lived about the same time as Eudoxus, made the remarkable guess that the beautiful bright band called the 'Milky Way,' which stretches every evening right across the sky, is composed of millions of stars scattered like dust over the heavens.

**Aristotle, 384 B.C.**, one of the most famous philosophers of Greece, was also a great student of nature. He was born at Stagira, in Thrace, 384 B.C., but studied at Athens under Plato, and afterwards became the tutor of Alexander the Great. Aristotle did much for astronomy, by collecting and comparing the discoveries of the astronomers who came before him. He is the first of the Greek writers who states very decidedly that the earth must be a round globe, and he observed an eclipse (or occultation as it is termed by astronomers) of the planet Mars by the moon.

But the best scientific work of Aristotle was his study of animals. He persuaded Alexander the Great, who governed Greece at that time, to employ several thousand people to collect specimens of animals in all parts of Europe and Asia, and to send them to Athens. Here Aristotle examined them and arranged them under different classes according to their *organs*, or different parts of their body, and the manner in which they used them. Many of Aristotle's divisions of the animal kingdom are still in use, and he may fairly be called the Founder of Zoology. He pointed out that we can trace an unbroken chain from the lowest plant up to the highest animal, each group being only divided from the next by very slight differences; nor can we tell, he said, where plants end and animals begin, for there are some forms which are so like both plants and animals that we cannot decide in which division to place them.

He also pointed out that the life in plants is much lower than in most animals; for if you cut a plant into pieces, the separate pieces will often grow, showing that the parts of a plant are simple and do not depend very closely upon each other. But any one of the higher animals is a most complicated piece of machinery. If you hurt or destroy any of the most important parts the whole body dies, and if you cut off any part whatever, that part dies as soon as it is separated from the rest. These and many other interesting facts about animals are to be found in Aristotle's great work on Natural History, which, however, you must remember, was only one out of many philosophical works written by him.

**Theophrastus, 371 B.C.**—Among the pupils of Aristotle was a man named Theophrastus, who was born at Eresus, 371 B.C. Theophrastus devoted himself chiefly to the study of plants, and is the first *botanist* whose name has

been handed down to us. The Greeks understood very little about plants except those which they used for medicine ; but Theophrastus described no less than 500 different kinds of plants, and divided them into trees, herbs, and shrubs.

## CHAPTER III.

320 to 212 B.C.

School of Science at Alexandria—The Ecliptic and the Zodiac—  
Aristarchus—Euclid—Archimedes.

WHILE Aristotle was studying science at Athens, the Greeks under Alexander the Great were making great conquests in Egypt, where Alexander founded a city bearing his own name on the shores of the Mediterranean. After Alexander's death this city, called Alexandria, fell to the portion of Ptolemy Lagus, one of Alexander's generals, who was succeeded by a number of princes of the same name. The Ptolemies were all patrons of learning and science, and the school of Alexandria became one of the most famous the world has ever known. By this time the Greeks had learnt many astronomical facts, some of them probably from the Egyptians. They had traced the *ecliptic*, or the sun's apparent yearly path through the heavens, and, dividing this path into twelve parts, they called each division by the name of a constellation or cluster of stars. These constellations received most of them the names of animals, and therefore the circle of the twelve constellations was called the *Zodiac*, or *circle of animals*. The names of the twelve signs are: 1. *Aries*, the Ram; 2. *Taurus*, the Bull; 3. *Gemini*, the Twins; 4. *Cancer*, the Crab; 5. *Leo*, the Lion; 6. *Virgo*, the Virgin; 7. *Libra*, the Balance; 8. *Scorpio*, the Scorpion;

9. *Sagittarius*, the Archer; 10. *Capricornus*, the Goat; 11. *Aquarius*, the Water-bearer; 12. *Pisces*, the Fishes.

It was by no means an easy thing to trace the sun's path among the stars, because the sun and the stars are never in sight at the same time, so astronomers were obliged to notice the constellations as they appeared close to the sun after he sank at night or before he rose in the morning. These, they found, varied a little each night, till when a whole year had passed away, each of the twelve signs had been in turn close to the sun, and the round began again. Thus they learned that the sun passed over each of the twelve signs in the course of the year; and they thought from this that the sun travelled round the sky while the earth stood still in the middle. We know now that it is the sun which stands still in the middle while the earth moves round, and it is worth while to make an experiment to see how the Greeks were deceived.

Put twelve chairs round in a circle to represent the signs of the Zodiac, and put yourself in the middle for a person standing on the earth. Then swing a ball round you just on a level with the chairs. You will see that the ball passes between you and each chair as it makes a circle round you. The Greeks believed that the sun moved round in this way between us and the stars. But now to represent what really takes place, change places with the ball. Hang the ball (the sun) up in the middle just on a level with the chairs, and walk round it. Keep your eye fixed on the ball, and you will see it will pass between you and each chair, just as it did before. The effect is the same, though it is you who are moving this time and not the ball. Thus the Greeks made the same mistake which a child does in a railway train when he thinks the houses and trees are flying past, while it is really he himself who is moving.

**Aristarchus.**—There was, however, one Greek astronomer named Aristarchus, who discovered the real movement as we know it now. Aristarchus was born in Samos, some time in the third century before Christ, but he came to Alexandria, and was tutor to the sons of one of the Ptolemies. He taught that the sun was immovable like the fixed stars, and that it was the earth which travelled round the ecliptic. He knew also that our earth does not stand quite upright in its journey round the sun, but that a line drawn through the earth from the north to the south pole would be sloping or *oblique* to the ecliptic, and that this obliquity is the cause of our four seasons.

If you do not understand this you can work it out with your ball, using a lamp to represent the sun. First draw an ink-line round the middle of your ball for the equator, then put your finger and thumb at the two ends of the ball to represent the two poles. Do not hold the ball upright, but bring your thumb nearer to you than your finger. A line drawn through the ball from your finger to your thumb will now be *inclined*, and will represent the inclined axis of the earth. Now look at the light and shade on the ball: the north pole, which is turned towards the lamp, will be in full light, and will have the long days of summer; the south pole turned towards you will be in the dark, enduring its long winter night. Pass the ball on to your right, and when you have gone round a quarter of a circle the poles will both have equal light, and the southern spring and northern autumn have arrived. Pass on again, and at the next quarter the south pole will be in summer and the north pole in winter, while at the fourth and last point you have the northern spring and the southern autumn. This was what Aristarchus discovered, namely, that the changing seasons are entirely caused by the earth having its axis (or the line



from pole to pole), *oblique* to its path round the sun, called the *ecliptic*. This is called the *obliquity of the ecliptic*.

Aristarchus appears also to have been the first Greek who understood that day and night are caused by the earth turning round on its axis every day. If the Greeks had understood his teaching, especially about the earth moving round the sun, they would have made much more progress in astronomy. But no one believed him, and more than 1700 years passed away before Copernicus, of whom we shall speak in Chapter IX., discovered this great truth over again. This Greek theory of the earth moving round the sun is often called the *Pythagorean system*, for it was thought that Pythagoras taught it; but we have seen that, though Pythagoras knew that the earth moves, he did not believe that it went round the sun.

**Euclid, 300 B.C.**—We must not pass through the third century before Christ without mentioning Euclid, the great mathematician and geometer, who collected together the propositions in the ‘*Elements of Euclid*,’ known to every schoolboy. He was born at Alexandria about 300 B.C. His works are too difficult for us to examine, and the only discovery of his we can mention is, that light travels in straight lines called ‘*rays*.’ Thus, if you look at a sun-beam shining across a dusty room, you can see the light reflected in a straight line along the particles of dust, and if you let sunlight through a hole in the shutter into a dark room, it will light up a spot on the wall or floor *exactly* opposite to the sun;—the middle of the sun, the middle of the hole in the shutter, and the middle of the spot of light, will all be in a straight line.

**Archimedes, 287 B.C.**—Another famous geometer, Archimedes of Syracuse, born 287 B.C., lived about the same time as Euclid. He studied for many years at

Alexandria, but afterwards returned to his native country. One of the greatest discoveries made by Archimedes was that of the principle of the lever. If you place a book upright on the table and lay a light ruler or flat piece of wood across it, you will find there is one point at which the ruler will balance. When you have balanced it, put an ounce weight on each end and it will still balance at the same point, which is called the *fulcrum*. But now change the ounce at one end for a weight of two ounces; that end will sink at once, and to make it balance you will have to shift the ruler till one end is longer than the other. You may go on doing this by adding more weight to the heavy end till that end is quite close to the *fulcrum* or resting-point of the ruler, and still the light weight will balance the heavy one.

This is the principle of the lever, and it is of great use in lifting weights. A heavy block of stone which no set of men could lift by taking hold of it may be easily raised by fastening it to the short end of a lever, and then the weight of the men at the end of the long arm will balance it, as the one-ounce weight balances the heavier weights at the other. Archimedes was so delighted when he made this discovery that he is said to have exclaimed: 'Give me a place on which to stand, and I will raise the world.'

Another remarkable discovery made by Archimedes concerns the weight of bodies immersed in water. Hiero, king of Syracuse, had given a lump of gold to be made into a crown, and when it came back he suspected that the workmen had kept back some of the gold, and had made up the weight by adding more than the right quantity of silver; but he had no means of proving this, because they had made it weigh as much as the gold which had been sent. Archimedes, puzzling over this problem, went to his bath. As he stepped in he saw the water, which his body dis-

placed, rise to a higher level in the bath, and to the astonishment of his servants he sprang out of the water and ran home through the streets of Syracuse almost naked, crying *Eureka! Eureka!* ('I have found it, I have found it').

What had he found? He had discovered that any solid body put into a vessel of water displaces a quantity of water equal to its own bulk, and therefore that equal weights of two substances, one light and bulky, and the other heavy and small, will displace different quantities of water. This discovery enabled him to solve his problem. He procured one lump of gold and another of silver, each weighing exactly the same as the crown. Of course the lumps were not the same size, because silver is lighter than gold, and so it takes more of it to make up the same weight. He first put the gold into a basin of water, and marked on the side of the vessel the height to which the water rose. Next, taking out the gold, he put in the silver, which, though it weighed the same, yet, being larger, made the water rise higher; and this height he also marked. Lastly, he took out the lump of silver and put in the crown. Now, if the crown had been pure gold, the water would have risen only up to the mark of the gold, but it rose higher and stood between the gold and silver mark, showing that silver had been mixed with it, making it more bulky; and, by calculating how much water was displaced, Archimedes could estimate roughly how much silver had been added. This was the first attempt to measure the *specific gravity* of different substances, that is, the weight of any particular substance compared to an equal bulk of some other substance taken as a standard. In weighing solids or liquids water is the usual standard.

It will be quite sufficient if you remember the experiment

as I have explained it ; but as you may perhaps be puzzled to see how it can have anything to do with weight, it will be well to try to master the following explanation of Fig. 1, which shows how specific gravity is measured. You must begin by remembering that the crown, the gold lump, and the silver lump, when weighed in the air, will all pull the marker of the spring balances A, B, C, down to 19 ; that is,

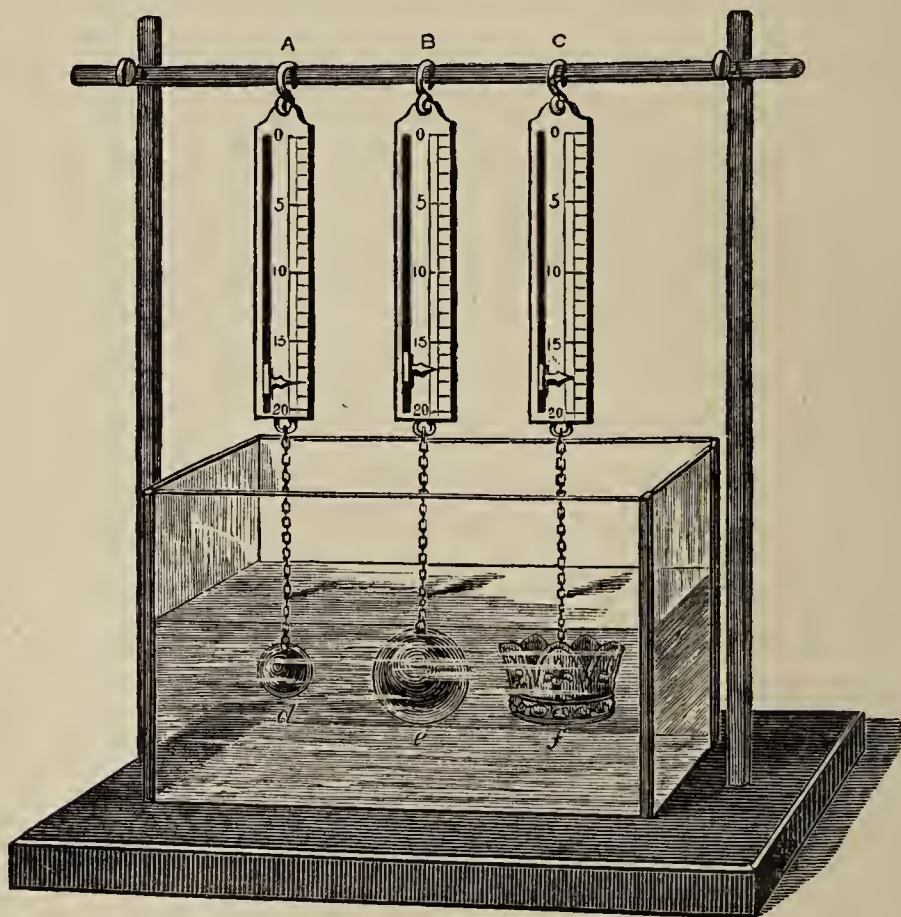

FIG. 1.

Diagram showing the difference of specific gravity between equal weights of gold, silver, and mixed metal.

A B C, Spring balances. *d*, Gold ball weighing 19 oz. *e*, Silver ball weighing 19 oz. *f*, Crown of mixed metal weighing 19 oz.

they will all weigh 19 ounces. But when they are immersed in water they will no longer weigh the same, because the water round them buoys them up just as much as it would buoy up the quantity of water which they displace.

Now, the gold takes the place of as much water as would weigh *one ounce* if you could take it out and weigh it in the air. So it is buoyed up *one ounce* by the water round it, and accordingly you see it only pulls the marker down 18 ounces instead of 19. But the silver, although it weighs the same, is larger, and takes the place of nearly *two ounces* of water, therefore it is buoyed up nearly two ounces, and only pulls the marker down to 17. Now, as the crown weighs the same as either of the two lumps, its shape is of no consequence; if it was made all of gold it would take as much room, and be buoyed up as much as the gold. If it was all silver it would be buoyed up as much as the silver, and therefore, as it pulls the marker down half-way between 17 and 18 ounces, it must be half gold and half silver.

In this way Archimedes showed how we can learn the weight of any solid compared to an equal bulk of water, and this is called the 'specific gravity' of the substance.

He also invented a screw for pumping up water, which is still called the 'screw of Archimedes.'

Archimedes was unfortunately killed in the city of Syracuse when it was besieged by the Romans during the second Punic war. The Roman general Marcellus had given special orders that his life should be spared; but he was so deeply engaged in solving a problem that he heard nothing of the din of war around him, and a common soldier not being able to get any answer from him, killed him without knowing who he was.

## CHAPTER IV.

280 TO 120 B.C.

Erasistratus and Herophilus—Eratosthenes—Hipparchus—Precession of the Equinoxes.

**Erasistratus and Herophilus.**—At the time when Archimedes was studying in Alexandria, two physicians were teaching there, who are famous in the history of *anatomy*, or the structure of the body. The one was Erasistratus and the other Herophilus. The birthplaces and dates of these two physicians are doubtful, but we know that they were the first men who dissected the human body, and gave a clear account of its parts. Erasistratus, in particular, described the brain and its curious windings or convolutions, and the division between the cerebrum or front part and the cerebellum or hinder and lower part. He seems also to have known that it is by means of our brain that we feel everything, and that it is the nerves which carry messages from different parts of our body to our brain. Herophilus traced out the tendons or strong cords which fasten the muscles to the bones; the ligaments or fibrous cords which unite one bone to another; and the nerves. He was the first physician who pointed out that in feeling a pulse you must notice three things: 1st, how strongly it throbs; 2d, how quickly; 3d, whether the beats are regular or irregular. Many of the names which Erasistratus and Herophilus gave

to parts of the body are still used by anatomists, and the school of medicine founded by them in Alexandria was renowned for more than six hundred years.

**Eratosthenes, 276 B.C.**—We must now turn to the science of geography, which at this time began first really to be studied by a Greek named Eratosthenes, born at Cyrene 276 B.C. Like all men of science of that day, he too came to Alexandria, where the king, Ptolemy Euergetes, made him keeper of the Royal Library. He made a map of all the world that was then known, and described the countries of Europe, Asia, and Libya; but he is chiefly famous for having laid down the first parallel of latitude, and trying to measure the circumference of the earth. He laid down the parallel of latitude in the following manner. He knew that at all places on the equator the day was exactly the same length all the year round, and that the length of the days and nights varied more and more as you went northwards; therefore he reasoned that, if he could draw a line east and west through a number of places whose longest day was exactly the same length, those places would all be at the same distance from the equator. He began at the Straits of Gibraltar, where the longest day was exactly  $14\frac{1}{2}$  hours, and then observing all those places whose longest day was also  $14\frac{1}{2}$  hours, he drew a line through the south coast of Sicily, across the south of the Peloponnesus, the island of Rhodes, the bay of Issus, and across the Euphrates and Tigris, out to the mountains of India. If you follow this line on a map you will find it is the 36th parallel of north latitude, and that Eratosthenes' observation was perfectly correct.

This discovery led him on to try and measure the circumference of the earth. Having found a line straight round the earth from east to west, he knew that if he drew a line at right angles to it, that is exactly north and south,

he should have a line which would describe a circle round the earth from pole to pole, as the equator marks a circle round the earth midway between the two poles. This second line he drew from Alexandria, and it passed right through Syene, now called Assouan, one of the southern cities of Egypt; and thus he knew that Alexandria and Syene were on the same meridian of longitude.

Now he found that at Syene the sun was exactly overhead at mid-day, at the time of the summer solstice. He knew this by means of a gnomon, or upright pillar (B, Fig. 2), which was used by the Greeks to measure the height of the sun in the sky. At Syene this pillar cast no shadow at noon of the summer solstice, proving that the sun shone straight down upon the top of it; and this was further proved by the sun shining down to the bottom of a deep well, which it would not do unless it were directly overhead. But at Alexandria the gnomon did cast a shadow, because, as Alexandria was farther north and the earth is round, the sun there was not directly overhead. Now, as light travels in straight lines (see p. 21), a line drawn from the extreme point of the shadow cast by the pillar or gnomon up to the top of the pillar itself would, if carried on, run straight into the sun, and thus the angle between this line and the pillar showed at what angle the sun's rays were falling at Alexandria. By measuring this angle, Eratosthenes found that Alexandria was  $\frac{1}{50}$ th of the whole circumference of the earth north of Syene, where the rays were perpendicular.

You can form an idea of this from the accompanying diagram, Fig. 2. Let the large circle represent the earth; B the gnomon at Syene, and A the gnomon at Alexandria. The length of the shadow CD of the gnomon A, will bear the same proportion to the circumference of the small circle (drawn from the top of the gnomon as a centre), that the



distance from Alexandria to Syene (D to E) does to the whole circumference of the globe. This is true only if the rays from the sun to Alexandria and to Syene are parallel (or run at equal distances).

They are not really quite parallel because they meet in the sun, but Eratosthenes knew that the sun was at such an enormous distance that their approach to each other was quite unimportant. He now measured the distance between Alexandria and Syene, and found it to be 5,000 stadia, or about 625 miles, and multiplying this by 50 he got  $625 \times 50 = 31,250$  miles as the whole circumference of the earth, measured round from pole to pole. This result is not quite correct, but as nearly as could be expected from a first rough attempt.

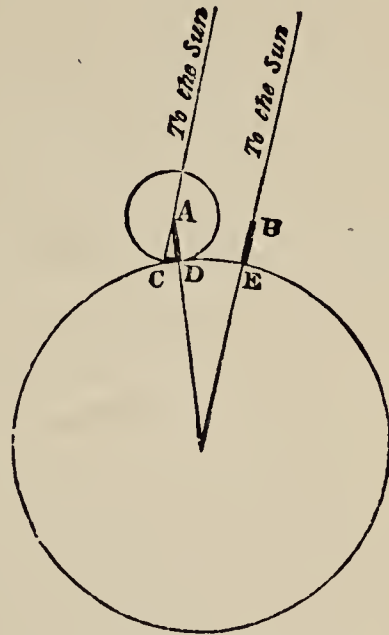

FIG. 2.

Diagram showing how Eratosthenes measured the circumference of the earth.

A, Gnomon at Alexandria. B, Gnomon at Syene. C D, Length of shadow of gnomon. D E, Distance from Alexandria to Syene.

Eratosthenes also studied the direction of mountain-chains, the way in which clouds carry rain, the shape of the continents, and many other geographical problems.

**Hipparchus, 160 B.C.**—Nearly one hundred years after Eratosthenes, the great astronomer Hipparchus was born, 160 B.C. Hipparchus was the most famous of all the astronomers who lived before the Christian era. He collected and examined all the discoveries made by the earlier observers, and made many new observations; but astronomy had now become so complicated that the problems are too diffi-

cult to be explained here. Hipparchus made a catalogue of 1080 stars, and showed how they are grouped with regard to the ecliptic. He also calculated accurately when eclipses of the sun or the moon would take place. But his great discovery was that called the 'Precession of the Equinoxes.' This is a very complicated movement which can only be understood by reading works on Astronomy; but I will try to give a rough idea of it, in order that you may always connect it with the name of Hipparchus.

We have seen that the earth has two movements—one, turning on its own axis causing day and night; the other, travelling round the sun, causing the seasons of the year. But besides these it has a third curious movement, just like a spinning-top when it is going to fall. Look at a top a little while before it falls, and you will see that, because it is leaning sideways, the top of it makes a small circle in the air. Now our earth, because it is pulled at the equator by the sun, moon, and planets, makes just such a small circle in space; so that, instead of the north pole pointing quite straight to the polar star, it makes a little circuit in the sky, with the polar star in the centre. The pole moves very slowly, taking twenty-one thousand years to go all round this circle. To understand the effect of this movement we must examine more closely what the equinoxes are. Take your ball again and make it go round the lamp with its axis inclined (see p. 20). When you have it in such a position that the north pole is in the dark, or the northern winter solstice, you will find that a straight line drawn from the sun to the centre of the earth will not meet the equator but a point to the south of it. But now pass the ball on to the next point when neither pole is in shade, and when it is equal day and equal night over the globe (our spring equinox), a line now drawn from the sun will fall directly upon

the equator, so that the sun's path meets the equator at this point, which is called the equinoctial point. Pass on till the south pole of your ball is in the dark, the sun will now fall directly on a point *north* of the equator (making our summer solstice). Pass on again to the point of equal day and equal night, and the sun again falls direct on the equator, causing our autumn equinox. Now, if the earth did not make that small circle in space like the top, the sun would always touch the equator at exactly those same points of the earth's *orbit* or path round the sun; but the effect of that movement is to pull the equator slightly back, so that the points where the ecliptic and the equator cut each other are  $50\frac{3}{4}$  seconds more to the west every year, and in this way the equinoxes would travel all round the orbit from east to west in about 26,000 years were it not that a gradual change in the direction of the major axis of the earth's orbit, known as "the revolution of the apsides," shortens the period and reduces it to 21,000 years. Hipparchus discovered this *precession* (or going forward) of the equinoxes; though he did not know, what Newton afterwards discovered, that it is caused by the sun and moon pulling at the mass of extra matter which is gathered round the equator.

## CHAPTER V.

FROM A.D. 70 TO 200.

Ptolemy—Ptolemaic System—Strabo—Pliny—Galen—Greece and her Colonies conquered by Rome—Decay of Science in Greece—Concluding Remarks on Greek Science.

**Ptolemy, A.D. 100.**—After Hipparchus there were many good astronomers at Alexandria, but none whom we need notice until the period from 100 to 170 after Christ, when Claudius Ptolemy, the great astronomer, flourished. Claudius Ptolemy was a native of Egypt. He was not one of the Ptolemies who governed Alexandria, and the place and date of his birth are unknown, but he is famous for having made a regular system of astronomy founded upon all that the Greeks had learnt about the heavens. His discoveries, like those of Hipparchus, are too complicated for us to discuss here ; they related chiefly to the movements of the moon and the planets ; but the one great thing to be remembered of him is, that he founded what is called the *Ptolemaic System* of astronomy, which tries to explain all the movements of the sun, stars, and planets, by supposing the earth to stand still in the centre of them all. This system is contained in Ptolemy's great work called 'The Syntaxis.' It may seem strange that as it is not true that the earth is the centre, Ptolemy should have been able to explain so much by his system, but you must remember that it had the same effect

whether you moved round the ball, or the ball round you, in our experiment on page 19 ; and Ptolemy's explanations were apparently so near the truth that astronomers were satisfied with them for 1400 years, till Copernicus discovered the real movements.

Ptolemy was a geographer as well as an astronomer ; he wrote a book on geography which was used in all the schools of learning for nearly fourteen hundred years. He drew maps of all the known parts of the world, and laid down on them lines of latitude and longitude, which he calculated by the rules Eratosthenes had discovered. In his geography he describes the countries from the Canary Islands on the west to India and China on the east, and from Norway to the south of Egypt. He describes our island under the name of Albion, or Britain, and traces out many of the coast-lines and rivers. He also gives the names of the various towns, with their latitude and longitude.

**Strabo and Pliny.**—Between the beginning of our era and the time of Ptolemy there lived two remarkable men who require a passing mention. The first of these was a famous traveller named Strabo, who wrote a great deal on geography. He was born at Amasia, in Cappadocia, and was probably living when Christ was born. Strabo in his book describes the countries which he visited and read about. He also studied earthquakes and volcanoes, and pointed out that when the hot vapour and lava hidden in the crust of our earth cannot escape, they cause earthquakes, but that when they find their way out through a volcano, like Etna, the country is not so often disturbed and shaken. The second of these men, Pliny, the famous naturalist, was born A.D. 23, and died in the year 79 in a rash attempt to approach Vesuvius during the celebrated eruption which overwhelmed Herculaneum and Pompeii.

Pliny wrote much on Natural History, but he did not make many original observations.

**Galen, 131.**—There is still one more great man of science whom we must mention as having studied at the Greek school at Alexandria. This was Galen, one of the most celebrated physicians of antiquity. He was born A.D. 131, at Pergamos, in Asia Minor, where he received a liberal education, comprising all the branches of science known to the Greeks. He then turned his attention to medicine, and travelled to Smyrna, Corinth, and Alexandria. After practising for some time in his native country he went to Rome, where he became very famous. During his life he is said to have written more than 500 valuable essays on medicine and the human body. You will remember that Erasistratus and Herophilus dissected the human body; but in the time of Galen this seems to have been forbidden, and he was obliged to work upon monkeys and other animals. Even from these, however, he learnt some very important facts. For instance, he discovered the difference between the two sets of nerves which we have in our body, called the nerves of *sensation* and the nerves of *motion*.

Our bodies are provided with two sets of fine cords or threads called nerves; one set running from different parts of the body to the spine and the brain, and the other set running back from the spine and brain to the body. If you touch a hot iron with your finger, the nerves of sensation, that is, of feeling, carry the message to your brain that the iron is hot, and then instantly the nerves of motion carry the message back from your brain to your finger, and you snatch it away. If the nerves between your finger and your brain had been cut or injured you would not feel pain when you touched the hot iron, nor draw your finger away. You will remember that Erasistratus had an idea that it is

in our brain that we feel ; Galen proved this by many experiments, though he did not understand clearly the whole action of the nerves. He also proved that the veins of our body contain blood, and he described the two muscles which by their contraction pull down the lower jaw as we open and pull it up as we shut our mouths. Besides these and many other discoveries, Galen worked out a whole theory of medicine, and how doctors were to treat their patients, and his rules were the guide of physicians for many hundred years.

**Concluding Remarks on Greek Science.**—We have now come to an end of the science of the Greeks. You will read in Grecian history how Greece and the Greek colonies were conquered by the Romans more than a hundred years before Christ was born ; and when the Greeks ceased to be a free people they gradually lost their love of discovery and of science. The school at Alexandria continued to be famous for many centuries after Christ, but the professors who taught there only repeated the sayings of Ptolemy, Aristotle, Galen, and the other great discoverers, and did not find out new facts for themselves ; and at last, in the year 640 after Christ, the Arabs took possession of the city, and it soon ceased altogether to be Greek.

You must remember that in these five chapters we have only been able to speak of some of the greatest men, and then only of a few of the discoveries they made. You will hear of many celebrated Greek philosophers, as, for example, Sócrates and Plato, whose names are not mentioned here because they taught on subjects such as the mind and the soul, which belong to higher philosophy, and not to Natural Science. You will also hear of many strange and absurd notions about the causes of things which in those early

days were held, even by such men as Pythagoras or Galen ; but in this book we have only to try to understand the real facts which have been discovered ; and there is no doubt that the Greeks, by a patient study of nature, and by making real and careful observations and experiments, laid the foundations of much of the knowledge which we have carried so much farther in modern times. The moment they began merely to repeat the teachings of others, instead of trying and proving the truth of them, they made no more discoveries, but lost a great deal they had gained. For a mere reading of books will not teach science ; and if you admire these men for making great discoveries, and would like to be a discoverer yourself, you must not be content with knowing what has been done, but must set to work as they did, and observe and make experiments for yourself.

---

*Chief Works consulted.* — Draper's 'Intellectual Development in Europe ;' Lewis's 'Astronomy of the Ancients ;' 'Encyclopædia Britannica,' art. 'Astronomy ;' Herschel's 'Astronomy ;' Baden Powell's 'History of Natural Philosophy ;' Lardner's 'Cyclopædia,' 1834 ; Sprengel's 'Histoire de la Médecine,' 1815 ; Grant's 'History of Physical Astronomy ;' Lange's 'Geschichte des Materialismus ;' Rees' 'Encyclopædia ;' Whewell's 'History of Inductive Sciences.'



PART II.

SCIENCE OF THE  
MIDDLE OR DARK AGES

FROM A.D. 700 TO A.D. 1500

*Chief Men of Science in the Middle Ages.*

	A.D.
Marcus Græcus . . . . .	800.
Geber or Djafer . . . . .	830.
Albategnius . . . . .	879.
Ben Musa . . . . .	900.
Avicenna . . . . .	980.
Gerbert . . . . .	1000.
Eben Junis . . . . .	1008.
Alhazen . . . . .	1000.
Roger Bacon . . . . .	1214.
Vitellio . . . . .	1220.
Flavio Gioja . . . . .	1300.
Columbus . . . . .	1435.
Vasco de Gama . . . . .	1450.
Ferdinand Magellan . . . . .	1470.
Leonardo da Vinci . . . . .	1452.

## CHAPTER VI.

## SCIENCE OF THE ARABS.

Dark Ages of Europe—Taking of Alexandria by the Arabs—The Nestorians and Jews translate Greek works on Science—Universities of the Arabs—Hermès the first Alchemist—Gases and Vapours called ‘Spirits’ by the Arabs.

**Arabian Science.**—We have now arrived at what have been called the ‘Dark Ages,’ because for several hundred years Europe was too much engaged in wars and disputes to pay any attention to learning or science. You have, no doubt, read in history how the Goths and Vandals, a barbarous people from north-eastern Asia, spread themselves over Europe, conquering the Romans, and taking possession of all their colonies. They even crossed over into Africa, but were driven out again by the famous general Belisarius, in the reign of Justinian. This was in A.D. 534, and the Emperors of Constantinople held Alexandria for about one hundred years, and then came the Arabs or Saracens, pouring out of Arabia, and they took possession of Alexandria in A.D. 640, only seven years after the death of their great leader Mahomet.

This people, who were originally a shepherd race in Arabia, seemed at first to think of nothing but making themselves masters of new lands. They went on conquering and destroying till they had overrun all the north of Africa up to the Straits of Gibraltar, had taken possession of a great

part of Spain, and even of the south of France as far as the river Aude, in Languedoc, and then when Charles Martel, mayor of the Franks, conquered them at Tours in 732, and stopped them from going any farther, they settled down and began to give their attention to science and learning.

They found in Arabia and in Egypt two classes of people who were able to teach them the Science of the Greeks. These were the Nestorians and the Jews. The Nestorians or followers of Nestorius, Patriarch of Constantinople, were a peculiar sect of Christians, who had fled from Constantinople about the year 450, and founded a Church of their own. They became very powerful and learned, and translated many of the Greek works of science into the Arabian language. The Jews, after the fall of Jerusalem, had also taken refuge in Syria and Mesopotamia, and they were very skilful in medicine, and founded many medical colleges. The Arabian schools of Bagdad, Cairo, Salerno in the south of Italy, and Cordova in Spain, soon became famous all over the world. The Arabs were not able to practise anatomy in their medical schools, because the Koran, that is the Mahomedan Bible, taught that it was not right to dissect the human body, so they turned their attention chiefly to medicine, trying to discover what substances they could extract from plants and minerals, at first to serve as medicines, but soon for very different uses.

**Arabian Alchemists.**—They found something in the old Greek writings about the way to melt stones or minerals, so as to get out of them iron, mercury, and other metals; and also how to extract many beautiful colours out of rocks and earths. But the chief thing which interested them in the books of the Egyptians, Chaldeans, and Greeks, was the attempts these nations had made to turn other metals into gold, a discovery which tradition said had been made by

Hermes Trismegistus about 2000 years before Christ. We know very little of this Hermes, and indeed we are not sure whether he is not altogether an imaginary person ; but the *Alchemists*, as the people were called who tried to make gold, considered themselves followers of Hermes, and often called themselves *Hermetic philosophers*. To melt the mouth of a glass tube so as to close it was called securing it with 'Hermes, his seal,' and even to this day a bottle or jar which is closed so that it is air-tight is said to be hermetically sealed.

The Arabs were a very superstitious people, and believed in all kinds of charms ; and this idea of making gold in a mysterious way took a great hold of them. Many thousands of clever men occupied themselves in the supposed magic art of *alchemy*. We need not study it here, but only observe how very useful it was in teaching the first facts of chemistry. These men, who were many of them learned, clever, and patient, spent their lives in melting up different substances and watching what changes took place in them. In this way they learnt a good deal about the materials of which rocks, minerals, and other substances are made.

One of the first things they discovered was that, by heating substances, they could often drive something out of them which was invisible, and yet that they could collect this invisible something in bottles ; and in some cases if they put a light to it, it exploded violently, breaking the bottle to atoms. Now because this was invisible, and yet so powerful, they thought it must be like the spirit of man, which can do so much and yet cannot be seen, and for this reason they called it 'spirit.' We know now that when we heat substances up to a certain point we drive apart the matter of which they are made, and it floats off as steam or gas into the air ; so that this *spirit* noticed by the Arabs was vapour or gas.

It seems almost certain that the Arabs knew a great deal about gunpowder and some other mixtures which explode when they are set on fire. Marcus Græcus, a man whose origin is unknown, but who lived about the beginning of the ninth century, says that if you mix together one pound of sulphur, two of charcoal, and six of saltpetre, it will explode when you light it and drive things into the air. This is one of the ways in which gunpowder is still made.

## CHAPTER VII.

## SCIENCE OF THE ARABS (CONTINUED)

Geber, or Djafer, the Founder of Chemistry—Arabs mix up Astronomy with Astrology—Albategnius—Mohammed Ben Musa first Writer on Algebra—Alhazen's Discoveries in Optics.

**Geber's Discoveries in Chemistry, 800-900.**—The greatest of the Arabian alchemists was a man named Geber, or Djafer, who was born in Mesopotamia about A.D. 830. He has been called the 'Founder of Chemistry,' for though, like his countrymen, he spent much of his time in trying to make gold, yet he is the first who, as far as we know, made really useful chemical experiments.

He explains in his works many of the methods we now use in chemistry. For example, he states that if you boil water, the vapour (or spirit as he calls it) will rise up, and you can collect it and cool it down again in another vessel; and it will then be pure, because any solid matter such as sand or salt, which does not turn readily into vapour, will remain behind in the first vessel. Again, if you heat wine or brandy gently, a vapour called *alcohol* or *spirits of wine* will rise up, because the alcohol turns into vapour more easily than the other materials of the wine. If you collect and cool down this vapour in another bottle, you will have liquid spirits-of-wine. This process is called *distillation*, and is used by chemists to separate substances which turn readily into vapour, from others which do not boil so easily.

You can distil vapours from solid things as well as from liquids : if you heat sugar over a fire, it will soon boil, and a vapour will rise up from it.

But if you put a piece of camphor in a flask with a stopper to it, and heat it very gently either by placing it in the sun or at some distance above a lighted candle, the camphor will gradually disappear from the bottom of the flask, and will collect again in little crystals on the inside of the neck. This is because camphor at an ordinary heat changes at once into a dry invisible gas, without first remaining liquid for a time as ice does. The process by which substances are turned directly from a solid state into a dry gas is called *sublimation*, and Geber describes it in his book as 'the elevation of dry things by fire.' He knew that if you take a kind of stone called cinnabar, and heat it, a dry gas rises from it, which you can collect, and which cools down into drops of *mercury* or quicksilver.

Geber made another remarkable experiment, though he did not thoroughly understand it. He states in his book that if you take a certain weight, say a pound of iron, lead, or copper, and heat it in an open vessel, the metal will weigh more after it has been heated than it did before, which seems very strange, as we cannot see that anything has been added to it. We shall learn the reason of this when we come to the discoveries of Priestley (Chap. XXVII.) ; but Geber carefully noticed the fact, though he could not explain it.

The discovery, however, which most of all gives Geber the right to be called the 'founder of chemistry' was that of strong acids. Most of the chemical experiments we make now would be impossible without acids, but before Geber's time vinegar seems to have been the strongest acid known. He found, however, that by heating copperas (or sulphate of iron) with saltpetre and alum, he could distil off



a vapour which cooled down into a very strong acid, now called *nitric acid*. He used this to dissolve silver, and by mixing it with sal-ammoniac he found it would even dissolve gold. Sal-ammoniac was a kind of salt which was known to the Arabs before Geber's time. They made it by heating the dung of camels, and the name *ammoniac* was given to it because they made it first in the desert near the temple of Jupiter Ammon. Geber also made *sulphuric acid* by distilling alum. When we remember that all these experiments were made more than a thousand years ago, we must acknowledge that Geber deserves great honour for the discoveries which he made.

**Albategnius, 879.**—We have seen that in chemistry the Arabs learned very little from the Greeks, but in mathematics and astronomy they found a great deal written, and the Arabian astronomers spent much of their time in translating Greek works. Unfortunately they mixed up *astronomy*, or the study of the heavenly bodies, with *astrology*, a kind of magic art, by which they imagined they could foretell what was going to happen by studying the stars. In spite of this, however, there were several very celebrated Arabian astronomers, one of whom, called Albategnius, born A.D. 879, made a great many good observations. He calculated the length of the year more exactly than Ptolemy had done, making it 365 days, 5 hours, 46 minutes, 24 seconds, which was only two minutes shorter than it really is, and he corrected many more of Ptolemy's observations. After him the next famous Arabian astronomer was Ebn Junis, A.D. 1008, who drew up several valuable astronomical tables.

**Ben Musa, 900.**—Of mathematicians, one of the most celebrated was Mohammed Ben Musa, who lived about A.D. 900. He is the earliest Arabian writer on Algebra, or the working of sums by means of letters, although we find

that a Greek writer, Diophantus, made use of this method some time in the fifth century. This name '*Algebra*' is an Arabian word, and the Arabs were very clever at this way of making calculations. Ben Musa is the first writer we know of who used the Indian numerals 1, 2, 3, 4, 5, 6, 7, 8, 9, 0, instead of the clumsy Roman numerals I. II. III. IV. ; etc. If you try to do a sum with the Roman numerals you will see what a troublesome business it is, and what a great gain the Indian numerals are. The Arabs learned these figures from the Hindoos, and always used them after the time of Ben Musa, so that they are now generally called the Arabic numerals. About the year 1000, a Frenchman named Gerbert, Archbishop of Rheims, and afterwards Pope Sylvester the Second, who had been educated at the famous Arabian University of Cordova in Spain, introduced them into Europe. The word *cipher*, which we use for 0, comes from an Arabic word, *ciphra*, meaning empty or void.

**Alhazen's discoveries in Optics, 1000.**— Another Arabian whom we must specially mention, was an astronomer and mathematician named Alhazen, who was born at Bassora, in Asiatic Turkey, about A.D. 1000, but who spent most of his life in Spain. He made discoveries chiefly in *optics*, or the science of light and vision. He was the first to teach that we see things because rays of light from the objects around us strike upon the retina or thin membrane of our eye, and the impression is carried to our brain by a nerve. When the object is itself a light, like the flame of a candle, it gives out the rays which reach our eye ; but when, like a book or a chair, it is not luminous, then the rays of the sun or any other light-giving body are reflected from it to our eye and make a picture there. Alhazen also explained why we do not see two pictures of one object, although we look at it with two eyes ; he pointed out that,

as the reflection of any given point of the object is formed on the same part of the one eye as of the other, only one united picture reaches the brain. This is the best explanation which has ever been given of why we only see one image, but even to this day we are not quite certain that it is satisfactory.

Alhazen discovered another wonderful thing about light.

If you take a straight stick and hold it in a slanting direction in a basin of water so that half of it is under water and look at it from above, the stick will appear to bend at the point A, where it touches the surface of the water, and instead of going along the dotted line to B, will look

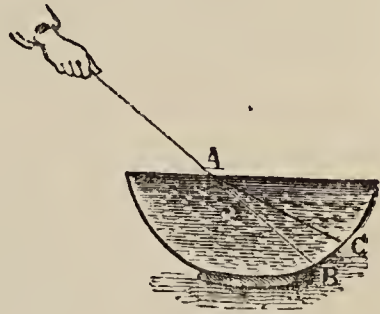

FIG. 3.

as if it went to the point c. This is because rays of light are bent in a slanting or *oblique* direction when they pass through substances of different density. Water is more dense than air, and therefore the rays of light reflected from the stick are bent as they pass out of the water into the air on their way to your eye. This is called *refraction*, or the breaking-back of a ray, and the discovery of it led Alhazen to find the explanation of a very curious natural fact.

He knew that the air round our globe grows denser as it gets nearer the earth, so he argued that the slanting rays from the sun, moon, and stars must become bent as they approach the earth and pass through the denser air. This, he said, causes us to see the sun after it has really sunk below our horizon at night, and before it rises in the morning; for the rays are gradually curved by passing through the denser air round our earth. Fig. 4 explains this. Supposing the sun to be at s, and a person at A, it is clear that any straight ray from the sun, such as s D, could not

reach A, because part of the earth is in the way ; neither could a ray, s c, reach the earth, because it would pass above it. But when the rays from s to c strike the atmosphere at B, they are bent out of their course, and are gradually curved more and more by the denser air till they are brought down to the earth at A, and so the sun becomes visible.

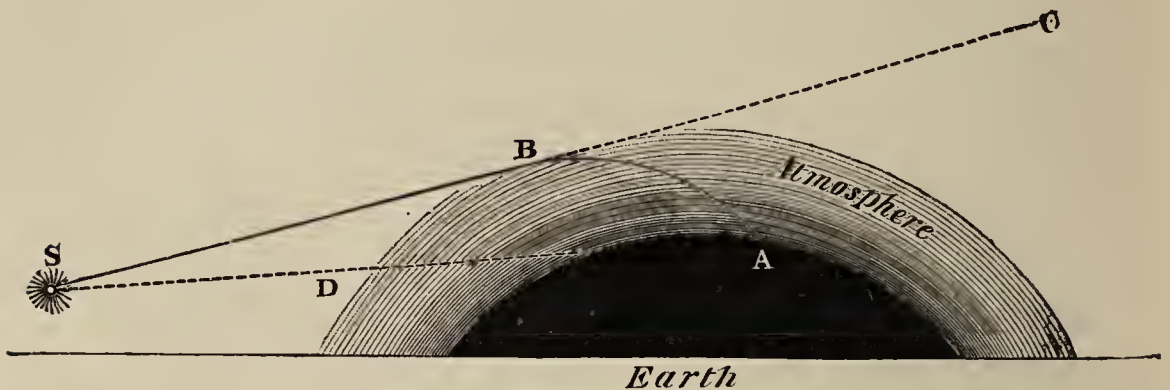

FIG. 4.

Bending of the Sun's rays by the atmosphere.

s, Sun. s c and s D, Rays as they would travel if there were no atmosphere.  
s B A, Ray bent so that the sun becomes visible from A.

Alhazen was also the first to explain why a *convex lens*, that is, a glass with rounded surfaces, such as our common magnifying glasses and burning glasses, will make things appear larger if held at a proper distance between the eye and any object ; namely, because the two surfaces of the glass, becoming more and more oblique to each other as they approach the sides, bend the rays inwards, so that they come to a focus in the eye. To understand this, draw a line of any kind, say a little arrow, on a sheet of paper, and bring your eye near to it. Your arrow being so close would look very large if you could see it distinctly, but just because it is so near, your eye cannot *focus* or collect together the rays coming from it so as to make a picture on the retina at the back of the eye ; therefore you see nothing but an indistinct blur. But now, keeping your eye in the

same position, take a magnifying glass, C D, Fig. 5, and hold it between your eye and the arrow. If you hold it at the right distance you will now see the arrow distinctly, because the greater part of the rays have been bent or *refracted* by the rounded glass so as to come into focus on your retina. But now comes another curious fact. It is a law of sight, that when rays of light enter our eye we follow them out in straight lines, however much they may have been bent in coming to the eye. So your arrow will not appear to you

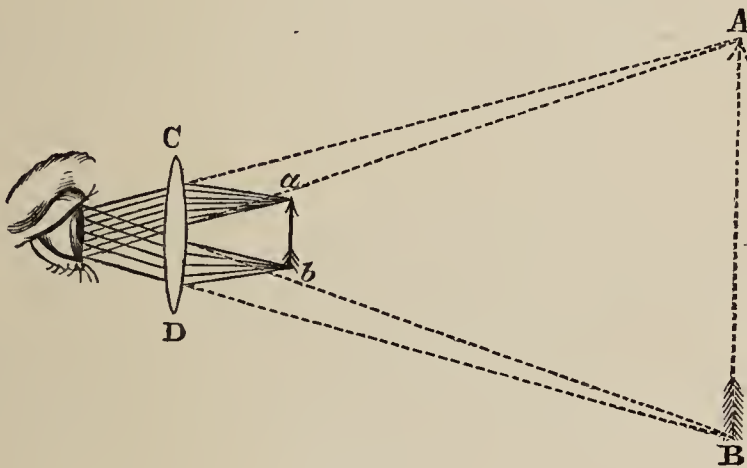

FIG. 5.

Arrow magnified by a convex lens.

*a b*, Real arrow ; *c d*, Magnifying glass ; *A B*, Enlarged image of the arrow.

as if it were at *a b*, but, following out the dotted lines, you will see a magnified arrow, *A B*, at the distance at which you usually see small objects distinctly. This observation of Alhazen's about the bending inwards or *converging* of rays through rounded glasses was the first step towards spectacles.

Besides the Arabians whom I have mentioned here, there were many who were very celebrated, but we know very little of their works. Among them was Avicenna A.D. 980, whom you will often hear mentioned as a writer on minerals. But the chief thing to be remembered, besides the dis-

coveries of Geber and Alhazen, and the introduction of the Indian numerals, is that in the Dark Ages, when all Europe seemed to care only for wars and idle disputes, it was the Arabs who kept the lamp of knowledge alight and patiently led the way to modern discoveries.

## CHAPTER VIII.

## SCIENCE OF THE MIDDLE AGES (CONTINUED).

Roger Bacon—His 'Opus Majus'—Flavio Gioja invents the Mariner's Compass—Use of the Compass in discovering new Lands—Columbus—Vasco de Gama—Magellan—Invention of Printing—Leonardo da Vinci.

WE must now return to Europe, where the nations were struggling out of the Dark Ages; and though there were many learned men in the monasteries, very few of them paid any attention to science: while those who did, often lost their time in alchemy, trying to make gold; or in astrology, endeavouring to foretell events by the stars.

**Roger Bacon, 1214.**—In the year 1214, however, a man was born in England whom every Englishman ought to admire and revere, because in those benighted times he gave up his whole life to the study of the works of nature, and suffered imprisonment in the cause of science. This was Roger Bacon, a great alchemist, who was born at Ilchester in Somersetshire, educated at Oxford and Paris, and then became a friar of the order of St. Francis. For this reason he is often called Friar Bacon. Bacon's great work, called the 'Opus Majus,' is written in such strange language that it is often difficult to find out how much he really knew and how much he only guessed at. We know, however, that he made many good astronomical observa-

tions, and that he explained the rainbow by saying that the sun's rays are refracted or bent back by the falling drops of rain, as was also noticed about the same time by Vitellio, a Polish philosopher.

Bacon is famous as the first man in Europe who made gunpowder ; we do not know whether he learnt the method from the Arabs, but it is most likely, for he gives the same receipt for making it as Marcus Græcus did—namely, saltpetre, charcoal, and sulphur. He also knew that there are different kinds of gas, or *air* as he calls it, and he tells us that one of these puts out a flame. He invented the schoolboy's favourite experiment of burning a candle under a bell-glass to prove that when the air is exhausted the candle goes out.

Bacon seems also to have known the theory of a telescope. We do not know whether he ever made one, but he certainly understood how valuable it would be. This is what he says about it in his 'Opus Majus,' or 'Greater Work': 'We can place transparent bodies (that is, glasses) in such a form and position between our eyes and other objects that the rays shall be refracted and bent towards any place we please, so that we shall see the object near at hand, or at a distance, under any angle we please ; and thus from an incredible distance we may read the smallest letter, and may number the smallest particles of sand, by reason of the greatness of the angle under which they appear.' This is at least a very fair description of the telescope and of the microscope. In the same book he says that one day ships will go on the water without sails, and carriages run on the roads without horses, and that people will make machines to fly in the air. This shows that he must have imagined many things which were not really discovered till more than 300 years afterwards ; but they



were all dreams which he could not carry out himself. Before we leave Roger Bacon I must warn you not to confuse him with Francis Bacon, Chancellor of England, who was quite a different man, and lived more than 200 years later.

**Flavio Gioja discovers the Mariner's Compass, 1300.**—About ten years after the death of Bacon, a man was born in a little village called Amalfi, near Naples, who made a discovery of great value. The man's name was Flavio Gioja, and the discovery was that of the *mariner's compass*. Long before Flavio's time people knew that there was a kind of stone to be found in the earth which attracted iron. There is an old story that this stone was first discovered by a shepherd, who, while resting, laid down his iron shepherd's crook by his side on a hill, and when he tried to lift it again it stuck to the rock. Although this story is probably only a legend, yet it is certain that the Greeks and most of the ancient nations knew that the loadstone attracted iron; and a piece of loadstone is called a *magnet*, from the Greek word *magnes*, because it was supposed to have been first found at *Magnesia*, in Ionia.

A piece of iron rubbed on a loadstone becomes itself a magnet, and will attract other pieces of iron. But Flavio Gioja discovered a new peculiarity in a piece of magnetised iron, which led to his making the mariner's compass. He found that if a needle or piece of iron which has been magnetised is hung by its middle from a piece of light string, it will always turn so that one end points to the north and the other to the south. He therefore took a piece of round card, and marking it with north, south, east, and west, he fastened a magnetised needle upon it pointing from N. to S.; he then fastened the card on a piece of cork and floated it in a basin of water. Whichever way he

turned the basin the needle carried the card round till the N. of the needle pointed to the north, and the S. to the south, and from the other marks on the card he could then tell the direction of the west, north-west, etc.

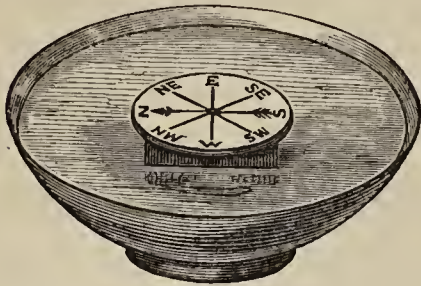

FIG. 6.

Flavio's Compass floating on water.

It is easy to see how important this discovery was; for when a ship is at sea, far from land, there is nothing to guide the captain except the stars, and they cannot always be

seen, so that before he had a compass he was obliged to keep in sight of land in order to find his way. But as soon as he had an instrument which pointed out to him which way his ship was going, he could steer boldly and safely right across the sea.

There has been much dispute as to who first discovered the compass, and some people think that the Chinese used it in very early times; but learned men now agree that Gioja discovered it independently, and it is certain that he was the first to use it in a ship. Of course it would have been very inconvenient to have it always floating in a basin of water; so the card was fitted, by means of a little cap, on to the top of a pin, round which it could turn easily, and this is the way it is still made. As the king of Naples of that day belonged to the royal family of France, Gioja marked the north point of the needle with a fleur-de-lys in his honour, and the mariner's compass of all nations still bears this mark. The territory of Principiato, where Gioja was born, has also a compass for its arms, in memory of his discovery.

**Invention of Printing, 1455.**—Before we go on to speak of the wonderful voyages which followed the inven-

tion of the compass, we must pause a moment to notice another great change which took place in Europe about a hundred years after the time of Bacon and Gioja. This was the invention of printing.<sup>1</sup> In the early part of the fifteenth century some people began to engrave, that is, to cut on wood, pictures and texts of Scripture, and then to rub them over with ink, and take an impression of them on paper. One day it occurred to a man named John Gutenberg, of Strasburg, that if the letters of a text could be made each one separate, they might be used over and over again. He began to try to make such letters, and with the help of John Faust of Mayence, and Peter Schoeffer of Gernsheim, both of them working mechanics like himself, he succeeded in making metal letters, or types as they are called. These men finished printing the first Bible in the year 1455. In 1465 the first printing-press was started in Italy, and another in Paris in 1469, while Caxton introduced printing into England in 1474.

This invention was a great step towards new knowledge. So long as people were obliged to write out copies of every work, new books could only spread very slowly, and old books were very dear and rare ; but as soon as hundreds of copies could be printed off and sold in one year, the works of the Greeks on science were collected and published by clever men, and were much more read than before ; and what was still more important, books about new discoveries passed quickly from one country to another, and those who were studying new truths were able to learn what other scientific men were also doing. Thus printing was one of the chief steps out of the ignorance of the Dark Ages.

**Voyages round the World.**—The next step, as I said

<sup>1</sup> The art of printing appears to have been practised by the Chinese as early as the beginning of the tenth century.

just now, was made by the use of the mariner's compass. The Greeks, as you will remember, knew that the earth was a globe, but all this had been forgotten in Europe since the Goths and Vandals came in, and people actually went back to the old idea that the world was flat like a dinner-plate, with the heavens in an arch overhead. Nevertheless, the sailors, who saw ships dip down and disappear gradually as they sailed over the sea, could not help suspecting that it must be a round globe after all ; and Christopher Columbus, a native of Genoa, was convinced he could find a way round to the East Indies by sailing to the west across the Atlantic. Full of this idea, he started on August 3, 1492, with three small ships and ninety men, from Palos, near Cadiz, in Spain, and sailed first to the Canary Islands. From there he sailed on for three weeks, guided by his compass, but without seeing any land ; the food in the ship began to run short, and his men became frightened and threatened to throw him overboard if he would not turn back ; but he begged them to continue for three days longer, and a little before midnight on October 11 there was a cry of 'land ! land !' and next morning at sunrise they disembarked on one of the Bahama Islands in the New World.

Columbus thought that he had sailed right round and reached the other side of Asia, but if you look at your map you will see he only went a quarter of that distance. He died in 1506, without finding out his mistake, though he made several other voyages. During these he made a very remarkable discovery about the magnetic needle of the compass. It had long been known that the needle did not point due north, but a little to the east of the north. Columbus, however, found that, as he went westward, the needle gradually lost its eastward direction, and pointed due north, and then gradually went a little way to the west.

It remained like this till, on his return, he came back to the same place where it had changed, and then it passed gradually back to its first position. From this he learnt that, although the magnetic needle always points towards the north, it varies a little in different parts of the world. The reason of this is not even now clearly understood, and we must content ourselves here with knowing that it is so.

The next grand voyage of discovery was made by Vasco de Gama, a Portuguese, who set sail July 9, 1497, to try whether it was possible to sail round the south of Africa. He succeeded, and during the voyage he could not help remarking the new constellations or groups of stars, never seen in Portugal, which appeared in the heavens. This proved to him that the earth must certainly be a globe, for if you were to sail for ever round a flat surface, you would always have the same stars above your head.

At last there came a third discoverer, Ferdinand Magellan (or Magalhaens), of Spain, who set off August 10, 1519, determined to sail right round the world. He steered westward to South America, and discovered the Straits which separate Terra del Fuego from the mainland, and which were called after him the Straits of Magellan. Then he sailed northwards, across the equator again, till he came to the Ladrone Islands, where he was killed fighting a battle to help the native king. Sebastian del Cano, his lieutenant, then took the command of the ship, which arrived safely back in the port of St. Lucar, near Seville in Spain, on September 7, 1522. This ship, guided by Magellan, was the first which ever sailed quite round the world; and all these voyages, proving that the earth is a round globe, and bringing back accounts of new stars in the heavens, set men thinking that there was much still to be learnt about the universe.

**Leonardo da Vinci, 1452.**—We must not pass on into the sixteenth century without mentioning Leonardo da Vinci, the great painter, who was also very remarkable for the number of interesting inventions which he made in mechanics. Leonardo was born in 1452 at Vinci, in Tuscany; he is so generally spoken of as a painter that many people do not know that he left behind him fourteen valuable works on Natural Philosophy. He invented water-mills and water-engines, as well as locks to shut off the water, such as are now used on our canals and rivers. He studied the flight of birds, and tried to make a mechanical apparatus for flying, and, besides being one of the best engineers of his day, he made many curious machines, such as a spinning machine, a water-pump, and a planing-machine. Some of these things were only models which he made for his own pleasure, but they show that he, like Roger Bacon, was very much in advance of his age; and he did good service to science by the careful experiments which he made, and by insisting that it was only by going to Nature herself that men can really advance in knowledge.

---

*Chief Works consulted.*—Draper's 'Hist. of Intellectual Development;' Baden Powell's 'Hist of Natural Philosophy,' 1834; Sprengel 'Histoire de la Médecine,' 1850; 'Penny Cyclopædia,' art. 'Arabians;'; 'Encyclopædias Metropolitana and Britannica;'; Rodwell's 'Birth of Chemistry,' 1874; 'The Works of Geber,' Englished by R. Russell, 1678; Whewell's 'History of the Inductive Sciences;'; Priestley's 'History of Vision,' 1772; Smith's 'Optics,' 1778; 'Edinburgh Encyclopædia,' art. Chemistry; Bacon's 'Opus Majus,' by Dr. Jebb, 1733; Bacon, 'Sa Vie, ses Ouvrages, et ses Doctrines,' by M. Charles, 1861; Ventura, 'Ouvrages Physico-mathématiques de Léonardo da Vinci,' 1797; Draper's 'Conflict between Religion and Science,' 1875.

PART III.

RISE AND PROGRESS OF  
MODERN SCIENCE

FROM A.D. 1500 TO THE PRESENT DAY

*Chief Scientific Men of the Sixteenth Century.*

	A. D.
Copernicus . . . .	1473-1543.
Paracelsus . . . .	1493-1541.
Vesalius . . . .	1514-1564.
Fallopium . . . .	1520-1563.
Eustachius . . . .	— -1570.
Gesner . . . .	1516-1565.
Cæsalpinus . . . .	1519-1603.
Baptiste Porta . . . .	1545-1615.
Gilbert . . . .	1540-1603.
Tycho Brahe . . . .	1546-1601.
Galileo . . . .	1564-1642.
Stevinus . . . .	— -1633.
Van Helmont . . . .	1577-1644.
Giordano Bruno . . . .	— -1600.



## CHAPTER IX.

## SCIENCE OF THE SIXTEENTH CENTURY.

Rise of Modern Science—Dogmatism of the Middle Ages—Copernicus—Copernican Theory of the Universe—Vesalius on Anatomy—Fallopian and Eustachian, Anatomists—Gesner the Naturalist—Cæsalpinus the Botanist—Chemistry of Paracelsus and Van Helmont.

WE have now arrived at the beginning of Modern Science, when the foundations were laid of that knowledge which we possess to-day. With the exception of some original discoveries made by the Arabs, learned men during the Dark Ages had spent their time almost entirely in translating and repeating what the Greeks had taught; till at last they had come to believe that Ptolemy, Galen, and Aristotle had settled most of the scientific questions, and that no one had any right to doubt their decisions. But as Europe became more civilised, and people had time to devote their lives to quiet occupations, first one observer and then another began to see that many grand truths were still undiscovered, and that, though the Greeks had learned much about nature, yet their greatest men had only made the best theories they could from the facts they knew, and had never intended that their teaching should be considered as complete or final.

And so little by little real observations and experiments began to take the place of mere book-learning, and as soon as this happened science began to advance rapidly—so rapidly that from this time forward we can only pick out the

most remarkable among hundreds of men who have added to the general stock of knowledge. A detailed account of all the steps by which the different sciences progressed would fill many large volumes, and would only be confusing except to those who already know a great deal about the subject. In this book we can only throw a rapid glance over the last four centuries of modern science, and try to understand such new discoveries as ought to be familiar to every educated person. It is, therefore, very important to bear in mind that when we come to a great man who discovers or lays down new laws, there have always been a number of less-known observers who have collected the facts and ideas from which he has formed his conclusions, although to mention all these men would only fill the pages with a string of useless names.

It is also necessary to explain why the plan is adopted of giving new discoveries in the order in which they occurred. Each separate science would no doubt have been easier to follow, if the account of it had been carried on without any break—if, for example, Astronomy had been spoken of first, then Optics, then Mechanics, and so on. But this arrangement would not show the gradual way in which our knowledge has grown from century to century, nor how the work done in one science has often helped to bring out new truths in another. Therefore, although by following the order of dates we shall be forced sometimes to pass abruptly from one subject to another, this is, I believe, the best method of teaching the 'History' of Modern Science.

**Copernican Theory of the Universe, 1473-1543.**— It was stated (p. 32) that about A.D. 100 Ptolemy formed a 'System of the Universe' which supposed our little earth to be the centre of all the heavenly bodies; and the sun, together with all the stars and planets, to move round us

for our use and enjoyment. This system had been held and taught in all the schools for nearly fourteen hundred years, when, in the beginning of the sixteenth century, a man arose who set it aside, and proposed a better explanation of the movements which we see in the heavens.

In 1473, a few years before Columbus sailed for America, Nicolas Copernicus, the son of a small country surgeon, was born at Thorn, in Poland. From his earliest boyhood he had always a great love for science, and after taking a doctor's degree at Cracow, he went as Professor of Mathematics to Rome. About the year 1500 he returned to his own country and was made a canon of Frauenberg, in Prussia. Here he set himself to study the heavens from the window of his garret, and often all night long from the steeple of the cathedral. At the same time he read carefully the explanations which Ptolemy and other astronomers had given of the movements of the sun and planets. But none of their theories satisfied him, for he could not make them agree with what he himself observed, and, moreover, they required so many unlikely suppositions that it seemed almost impossible they could be true. For example, according to the Ptolemaic system, the movements of Venus and Mercury could only be explained by supposing a rigid bar, or something equivalent to it, to be connected at one end with the earth, and at the other with the sun, and these planets to revolve round some point on the same bar. The movements of Mars, however, being much more irregular, could not be explained by one bar, but required that this bar should have a joint at some point beyond the sun, so as to form a second bar revolving round the first, and even a third joint and a third bar were necessary to account for the whole of his irregularities. In order to get rid of this cumbersome and intricate machinery, which was

called the 'Theory of Epicycles,' Copernicus, after twenty years of labour, turned back to the simple explanation which Aristarchus had given (p. 21), and which was called the *Pythagorean System*, namely, that the sun stands still in the centre of our system, and that the earth and other planets revolve round it.

He had made a large quadrant, that is, an instrument for measuring the angular height of the sun and stars, and with this he made an immense number of observations on the different positions of the sun during the year, all proving how naturally the movements of the different planets are explained by supposing the sun to stand still in the middle. This he wrote down in his great work called 'The Revolutions of the Heavenly Bodies,' in which he taught that the earth must be round, and must make a journey every year round the sun. He gave his reasons for believing that Ptolemy was mistaken in believing the earth to be the centre of the universe, and added a diagram of the orbits of our earth and of the planets round the sun. He then went on to found upon this a whole system of Astronomy, too complicated for us to follow here; but he did not publish it, because he was afraid of public opinion; for people did not like to believe that our world is not the centre of the whole universe. At last his friends persuaded him to let his book be printed, and a perfect copy reached him only a few days before his death, which occurred in 1543, when he was seventy years of age.

This work was the foundation of modern astronomy, and the theory that the earth and planets move round the sun has ever since been called the *Copernican Theory*; but at the time it was published very few persons believed in it, and it was not till more than sixty years after the death of Copernicus that Galileo's discoveries brought it into general notice.

**Work of Vesalius on Anatomy, 1542.**—While Copernicus was proving to himself that Ptolemy's theory of the heavens was not a true one, a Belgian, named Vesalius, was beginning to suspect that Galen, though a good physician, had described the structure of man's body very imperfectly, because he had only been allowed to dissect animals.

Andreas Vesalius was born at Brussels in 1514. When he was quite a boy he had a passionate love for anatomy, and, as he had some little fortune, he gave up all his time to this study, and often ran great risks in order to get bodies to dissect ; for in those days it was still considered wicked to cut up dead bodies. In the year 1540 he became Professor of Anatomy at the University of Padua, in Northern Italy, and two years afterwards, when he was only twenty-eight years of age, he published his 'Great Anatomy,' in which *Human Anatomy*, or the structure of man's body, was carefully studied and described ; the different parts being illustrated by the most beautiful and accurate wood engravings, drawn by the best Italian artists.

In this book Vesalius pointed out that Galen, having learnt his anatomy from the bodies of animals, had described incorrectly almost all the bones which are peculiar to man. For example, in animals the middle part of the upper jaw, which holds the front and eye-teeth, is a bone separate from the sides of the jaw, and even in monkeys it remains separate while they are young ; but man is born with the upper jaw all joined into one solid piece. Now Galen had described man's upper jaw as composed of separate bones, and therefore it was clear that he had made his description from the skull of an animal. In all instances like this, and there are many, in which man differs from animals, Vesalius showed that it was necessary to examine the human skeleton, and not to trust merely to Galen's teaching.

This was a great step in science, and yet people had become so accustomed to follow authority blindly that Vesalius made many enemies by venturing to think that Galen could be wrong. It happened, unfortunately, that one day when he was dissecting the body of a Spanish gentleman who had just died, the bystanders thought that they saw the heart throb. His enemies seized upon this circumstance and accused him of dissecting a living man, and the judges of the Inquisition would have condemned him to death, if Charles V. of Spain, whose physician he had become, had not persuaded them to send him instead on a pilgrimage to Jerusalem. On his return from this pilgrimage he was shipwrecked on the island of Zante, one of the Ionian islands, and died of hunger when he was only fifty years of age. There are of course many faulty descriptions in Vesalius's work, for the study of anatomy was at that time only beginning; but he made the first attempt to appeal to *facts* instead of merely repeating what others had taught, and by this he earned the right to be called the Founder of Modern Anatomy.

There lived at the same time as Vesalius two other very celebrated anatomists, Gabriel Fallopius, of Modena, and Bartholomew Eustachius, of San Severino, near Naples, who both did a great deal to advance anatomy. Eustachius described the tube running between the mouth and the ear which is still called *Eustachian* tube, and made many very useful experiments; but, on the other hand, he attacked Vesalius very bitterly for his criticism of Galen's anatomy.

**Gesner's Works on Animals and Plants, 1551-1565.**—We now come to one of the most interesting lives of the sixteenth century. Many of us know very little of astronomy or anatomy, but any child who has gathered flowers in the country or looked at wild animals in the

Zoological Gardens must feel interested in Gesner, the first man since the time of Aristotle who wrote anything original about animals and plants.

Conrad Gesner was born at Zurich in 1516. He was the son of very poor parents, and, being left an orphan, was educated chiefly by the charity of an uncle and other friends; but his love of knowledge was so great that he conquered all difficulties, and after taking his degree as a medical man in 1540, earned enough by his profession, and as Professor of Natural History at Zurich, to carry on his favourite studies. He learnt Greek, Latin, French, Italian, English, and even some of the Eastern languages, and read works of science in all these tongues; and although he was very delicate, he travelled all over the Alps, Switzerland, Northern Italy, and France, in search of plants, and made journeys to the Adriatic and the Rhine in order to study marine and fresh-water fish. He employed a man exclusively to draw figures of animals and plants, and he made a zoological cabinet, which contained the dried parts of animals arranged in their proper order. This was probably the first zoological cabinet which ever existed. He also founded a botanical garden at Zurich, and paid the expenses of it himself. He took great interest in studying the medical uses of plants, and often hurt his health by trying the effects of different herbs. His friends once thought he had killed himself by taking a dose of a poisonous plant called 'Doronicum,' or 'Leopard's Bane,' but he recovered, and gave them a most interesting account of his own symptoms.

Between the years 1551 and 1565, Gesner published his famous 'History of Animals,' in five parts; two on quadrupeds, one on birds, one on fish, and one on serpents. In this book he describes every animal then known, and gives the countries it inhabits and the names it has been called, both

in ancient and modern languages. He calculates the average length of its life ; its growth, the number of young ones it will bring up, and the illnesses to which it is subject ; its instincts, its habits, and its use ; and to all this he adds careful drawings of the animal and its structure. Part of his information he gathered from books and friends, but the larger part he collected himself with great care, and to him we owe the first beginning of the Natural History of Animals in modern times.

In Botany he made the first attempt at a true classification of plants, and pointed out that the right way to discover which plants most resemble each other is to study their *flowers* and *seeds*. Before his time plants had been arranged merely according to their general appearance ; but he showed that this system is very false, and that, however different plants may look, yet if their seeds or flowers are formed alike, they should be classed in the same group. He did not live to publish his great work on plants, but left drawings of 1500 species, which were brought out after his death.

Gesner also wrote a book on Mineralogy, in which he traced out the forms of the crystals of different minerals and drew many figures of fossil shells found in the crust of the earth. The same year that this book was published he died of the plague. When he knew that his death was certain, he begged to be carried into his museum, which he had loved so well, and died there in the arms of his wife.

There is something very grand and loveable in the life of Gesner. Born a poor boy, he struggled manfully upwards to knowledge, and became rich only to work for science. Every one loved him, and he was well known as a peacemaker among his literary and scientific friends, and for the readiness with which he would lay aside his own work to help others. Yet, though he had to earn his own living, and



died before he was forty-nine, he became the first botanist and zoologist of his time, and left remarkably large and valuable works behind him. He was one of the bright examples of what may be done by a true desire for knowledge, and a humble, honest, loving nature; for while he helped others, he could never have accomplished what he did in zoology and botany if he had not made friends all over the world, who were ready to send him information whenever and wherever they were able.

**First Classification of Plants by Cæsalpinus, 1583.**

—Nearly thirty years after Gesner's death, Dr. Andrew Cæsalpinus, a physician and Professor of Botany at Padua, first tried to carry out his system of grouping plants according to their seeds. He began by dividing plants into trees and herbs, as Theophrastus had done (see p. 17). Then he divided the trees into two classes—1st, those which have the germ at the end of the seed farthest from the stalk, as in the walnut, where you will find a little thing shaped like a tiny heart lying just at the pointed end; 2d, those which have the germ at the end of the seed which is nearest the stalk, as in the apple. The herbs he divided into thirteen classes, according to the number of their seeds and the way in which they are arranged in the seed-vessels. Some plants, for example, have a single pod or seed-vessel, with a number of seeds inside it, as our common pea; others, like the poppy, have a seed-vessel divided into a number of little cells, each filled with seeds.

By grouping together all the plants which had the same kind of seed-vessel, Cæsalpinus made thirteen classes, and formed a system of plants which would have been a great help to botanists, and would soon have led them to make better systems if they had followed it; but it was not generally adopted, and for nearly a hundred years longer many

went on in the old way, collecting and naming plants without trying to classify them. Cæsalpinus knew about 1500 species of plants, 700 of which he had collected himself. He was the first to point out that the use of flowers which have no seed-vessels, but only *stamens* (or little thread-like stalks, tipped with yellow powder), is to drop the powder or pollen on flowers which have only seed-vessels and no stamens, and by this means to cause the seeds to grow and ripen. Such plants which have the stamens in one *flower* and the seed-vessel in another are now called Monœcious, while if the flower containing the stamens grows on a different *plant* from the one containing the seed-vessel, such plants are called Dioecious.

**Chemistry of Paracelsus and Van Helmont, 1520-1600.**—There is very little worthy of notice in the chemistry of the sixteenth century; but we must mention in passing two famous men: Paracelsus, who was born in 1493 at Einsiedel in Switzerland, and Van Helmont, born at Brussels in 1577.

Paracelsus was at one time Professor of Physic and Surgery at Basle, but he gave up his professorship and travelled about Europe during the greater part of his life. Among other things, he pointed out that air feeds flame, and that, if you put iron into sulphuric acid and water, a peculiar kind of air rises from it. He also succeeded in separating gold out of a mixture of gold and silver by using *aquafortis* or *nitric acid* which dissolves the silver and lets the gold fall to the bottom of the vessel. He did not, however, make many discoveries which are valuable now, and he taught a great deal that was absurd and bombastic.

Van Helmont was also a wandering physician, but as a chemist he was more careful in his experiments than Paracelsus. He seems to have known a great many different

---

gases, though he did not describe them clearly, and he particularly mentions the gas which rises from beer and other liquids which ferment. He called this *Gas sylvestre*. The chief thing to remember about Van Helmont is that he was the first writer to use the word 'gas,' which he took from the German word 'geist,' meaning 'spirit.'

---

*Chief Works consulted.*—Rees's 'Encyclopædia,' art. 'Copernicus ;' 'Encyclopædia Metropolitana,' art. 'Astronomy ;' 'Biographie Universelle,' art. 'Copernicus ;' Gassendi's *Life of Copernicus ;* 'Encyclopædia,' art. 'Anatomy ;' Cuvier, 'Histoire des Sciences Naturelles,' 1845 ; D'Orbigny, 'Dict. des Sciences Naturelles'—Introduction ; 'Encyclopædia,' art. 'Botany ;' Hofer, 'Histoire de la Physique et de la Chimie,' 1850.

## CHAPTER X.

## SCIENCE OF THE SIXTEENTH CENTURY (CONTINUED).

Battista Porta—Kircher—Dr. Gilbert—Tycho Brahe, the Danish Astronomer—Rudolphine Tables—Galileo on Mechanics and Physics—Summary of the Science of the Sixteenth Century.

**Battista Porta's Discoveries about Light, 1560.**—The next discovery in science was about Light, and it was made by a boy only fifteen years of age. Battista Porta was born in Naples in 1545. He was so eager for new knowledge, that, when quite a boy, he held meetings in his house for any of his friends to read papers about new experiments. These meetings were called 'The Academy of Secrets,' and in the year 1560, when Porta was fifteen, he published an account of them in a book called *Magia Naturalis* or 'Natural Magic.' In the seventeenth chapter of this book he relates the following experiment, which he had made himself.

He says he found that by going into a darkened room when the sun was shining brightly, and making a very small hole in the window-shutter, he could produce on the wall of the room, opposite the hole, images of things outside the window. These images were exactly the shape of the real objects, and had always their proper colours; as, for example, if a man was standing against a tree outside the house, the green leaves of the tree and the different colours of the man's clothes would be clearly shown on the wall. There was

only one peculiarity about the picture, it was always upside down, so that the man stood on his head, or the tree with its trunk in the air. The smaller the hole was, the clearer were the outline and the colours of the image, and Porta found that by putting a convex lens (that is, a glass with its surfaces bulging in the centre, see p. 49) into the hole he could get a still brighter and clearer picture at a particular point in the room

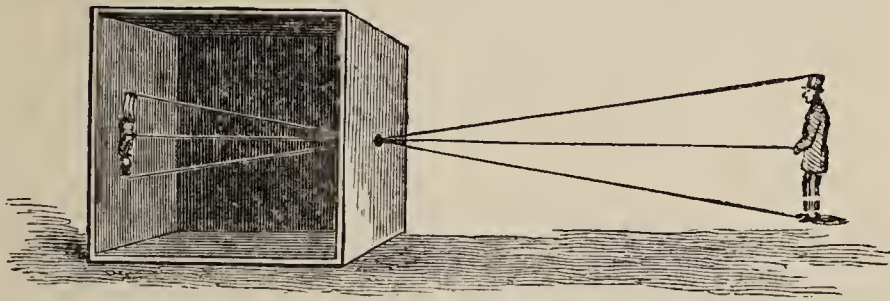

FIG. 7.

Porta knew from the works of Alhazen that rays of light are reflected in all directions from every object, and he explained this image on the wall quite correctly, by saying that the small hole lets in only *one ray* from each point of an object outside the other rays, and those from the sky and other objects, being kept out by the shutter. Thus these single rays fall directly on the wall without being mingled with others, and so make a clear picture. It is easy to see from Fig. 7 that the image must be upside down, because the rays cross in going through the hole. This simple discovery of Porta's is called the '*Camera Obscura*,' or '*Dark Chamber*.' You may perhaps have been into one at the sea-side, where they build them for visitors to watch the coloured reflection of the passers-by. In the camera obscura, as it is now made, the glasses are so arranged that the figures are upright.

Porta saw at once how useful this invention would be

for making accurate drawings of objects ; for, by tracing out with colours on the wall the figure of the man or tree as it stood, he could get a small image of it with all its proportions and colours correct. But, what is still more important, he was led by this experiment to understand how we see objects, and to prove that Alhazen was right in saying that rays of light from the things around us strike upon our eye. For, said Porta, the little hole in the shutter with the lens in it is like the little hole in our eye, which also contains a natural convex lens ; and we see objects clearly because the rays pass through this small hole. He did not, however, know which part of our eye represents the wall on which the figure is thrown, nor why we see objects upright ; we shall see (p. 94) that Kepler discovered this many years afterwards.

When Porta had succeeded in getting clear images of real things on the wall, he began to try painting artificial pictures on thin transparent paper and passing them across the hole in the shutter, and he found that the sun threw a very fair picture of them on the wall. In this way he produced representations of battles and hunts, and so made a step towards the *Magic Lantern*. He seems, however, never to have tried it by lamplight ; this was done by Kircher, a German, about fifty years later. There is no doubt that Porta had a very good notion of how to use two magnifying glasses so as to make objects appear nearer and larger, but it is not certain that he ever really made a telescope.

**Dr. Gilbert, the Founder of the Science of Electricity, 1540-1603.**—It was about this time, while Baptiste Porta was making experiments on light in Italy, that an Englishman named Gilbert made the first step in one of the most wonderful and interesting of all the sciences, namely, that of Electricity. So long ago as the time of the Greeks it was already known that amber, when rubbed, will attract

or draw towards it bits of straw and other light bodies, and it is from the Greek word *electron*—amber, that our word electricity is taken.

Until the sixteenth century, however, no one had made any careful experiments upon this curious fact, and it was Dr. Gilbert, a physician of Colchester, who first discovered that other bodies besides amber, will when rubbed, attract straws, thin shavings of metals, and other substances. You can easily try this for yourself by rubbing the end of a stick of common sealing-wax on a piece of dry flannel, and then holding the rubbed end near to some small pieces of light papers, or some feathers or bran. You will find that these substances will spring towards the sealing-wax and cling to it for a short time, being held there by the electricity which has been produced by rubbing the sealing-wax.

Gilbert showed that amber, jet, diamond, crystal, sulphur, sealing-wax, alum, and many other substances, have this power of attraction when they are rubbed, and he also proved that the attraction was stronger when the air is dry and cold than when it is warm and moist. This may seem very little to have discovered compared to the wonderful facts which we now know about electricity; but it was the first step, and Gilbert's book on 'Magnetism' (as he called it), which was published in 1600, must be remembered as the earliest beginning of the study of electricity.

**Tycho Brahe, Astronomer, 1546-1601.**—We must now return to Astronomy, in which during the next eighty years wonderful discoveries were made by three celebrated men, Tycho Brahe the Dane, Galileo the Italian, and Kepler the German.

Tycho Brahe was born in the year 1546, at Helsingborg, a town in Sweden, which at that time belonged to the Danes. When he was only fourteen he was so much

astonished that the astronomers had been able to foretell exactly the moment when an eclipse of the sun took place in 1560, that he determined to learn this wonderful science, which could predict events. His father had intended him to be a lawyer, but Tycho bought a globe and books with his own money, and studied astronomy in secret; till at last his family consented to let him follow his own inclination, and from that time he gave himself up to that science, planning and making the most beautiful instruments for taking observations in the heavens.

At this time the theory of Copernicus had made very little impression, and Tycho Brahe rejected it altogether and made a theory of his own called the *Tychonic system*, which was, however, soon laid aside and forgotten. This, however, mattered very little, for the useful work which Tycho did was not to lay down new laws, but to collect an immense number of accurate facts which were invaluable to the astronomers who came after him. For twenty-five years he lived in the little island of Huen, in the Baltic, which the King, Frederick II. of Denmark, had given him, making accurate observations of the different movements of the planet, and determining the positions of the fixed stars, of which he catalogued 777. He built there a magnificent observatory, which he called *Uranienborg*, or the City of the Heavens, and filled it with instruments of every kind, which enabled him to keep a register of the different positions of the heavenly bodies night after night.

When Frederick II. died, Tycho was persecuted and driven into exile by some envious people who grudged him the pension he was receiving. He then went to Bohemia, under the protection of the Emperor Rudolph II., and here he drew up the valuable astronomical tables called the Rudolphine tables, which, as we shall afterwards see, were



of immense use to Kepler. Tycho died in 1601, before Galileo and Kepler made their greatest discoveries.

**Galileo's Discovery of the Principle of the Pendulum, and of the Rate of Falling Bodies, 1564-1600.**—Galileo dei Galilei was born at Pisa in 1564. His father, though of good family, was poor, but being himself a man of talent and education, he made great exertions to send his son to the University of Pisa, meaning to educate him as a doctor. Here Galileo studied medicine under the famous botanist Cæsalpinus; but having also begun to learn geometry, he became so wrapt up in this pursuit that his father found it was useless to check him, and therefore wisely let him follow his natural bent. It was while he was still at the University, and before he was twenty years of age, that Galileo made his first discovery. When watching a lamp one day which was swinging from the roof of the cathedral, he noticed that, whether it made a long or a short swing, it always took the same time to go from one side to another. To make quite sure of this he put his finger on his own pulse, and, comparing its throbs with each swing of the lamp, found that there was always the same number of beats to every swing. Following up this simple observation he discovered that a weight at the end of a cord will always take the same time to swing backwards and forwards so long as the cord is of the same length and the arc through which the weight moves is small. This was the beginning of *pendulums*, such as we have now to our clocks, but at first they were only used by physicians to count the rate at which a patient's pulse beats.

In 1589 Ferdinand de' Medici, Duke of Tuscany, having heard of Galileo's talents, made him Lecturer on Mathematics at Pisa, and it was while he held this post that he made his next discovery, which was about falling bodies. He ob-

served that a stone or any other body, dropped from a height, falls more and more quickly from the time it starts till it reaches the ground, and after many experiments he succeeded in calculating at what rate its falling increases. At the end of the first second it will be falling at the rate of 32 feet per second, at the end of two seconds it will be falling at the rate of 64 feet per second, at the end of three seconds at the rate of 96 feet per second, and so it will continue, falling 32 feet faster every second till it reaches the ground.

Galileo explained this increase of velocity, or quickness of falling, in the following way : It is the weight of the stone, he said, which drags it down ; and when it had been once started downwards by its weight, it would go on moving at the same rate for ever, without any more dragging. But the weight still goes on pulling it down just as much at the end of the first second as it did when it started, and so the stone falls, first with the drag of its start, then with the drag of the first second added, then of the next, and the next all added together, until it reaches the ground.

This was quite a true explanation, so far as it went, and Galileo went on to prove another fact, which sounds very strange at first, namely, that if you let two weights, one light and the other heavy, drop from the same height, they will both take exactly the same time in falling to the ground. Galileo could not make the learned men of Pisa believe this, because Aristotle had said that a ten-pound weight would fall ten times as fast as a one-pound weight ; so to convince them he carried different weights up to the top of the Tower of Pisa, and let them fall before their eyes. Still, though they saw them reach the ground at the same moment, they would not believe, so obstinately were they determined to think with Aristotle ; and they actually an-

noyed Galileo so much on account of his opinions that he left Pisa and became a professor at Padua in 1592.

The best way for you to convince yourself that Galileo was right and they were wrong will be to take some large soft clay balls, say five, each exactly the same weight, and let them drop at the same moment from the same height—you can see at once that they will all reach the ground together. Then press four of the balls one against the other so that they stick together. They will now be four times heavier than the remaining ball, and yet if you let them drop from the same height again, there is no reason why the four should fall any faster merely because they are stuck together than when they were separate, and so the five will reach the ground together as they did before. I have said take large balls, because if they are not tolerably heavy the air will interfere with their falling accurately; indeed, to make the experiment very truly it ought to be made in a *vacuum*, that is, a space from which the air has been pumped out, for air buoys up bodies as water does, and this would retard the falling of a light body, especially if it had much surface, while it would be inappreciable in heavier ones. But air-pumps were not invented in Galileo's time, so he could not make the experiment very accurately.

In the year 1592 Galileo established another law in mechanics which is of great value, namely, that any force which will lift a weight of *two pounds up one foot* will lift a weight of *one pound up two feet*, or in other words, just as much as you make a weight lighter, so much higher the same force can lift it. If you double the weight, the same force will only lift it half as high; if you treble the weight, it will only lift it one-third as high, and so on. This law is of immense value in determining the balance of machines, but we cannot examine it further here. At about the same

time that Galileo was discovering these laws of motion, a famous engineer, named Stevinus, of Bruges, published a little book, in which he made known some very important laws about the rest and motion of bodies, which formed the foundation of the modern science of *statics*, or the study of bodies at rest.

**Galileo's Observations on Musical Notes.**—Galileo appears also to have made some curious observations on the subject of sound, and it was he who discovered that a musical note is produced by a number of shocks following rapidly and regularly one after the other, and that the more quickly one shock succeeds the other, the higher the note will be. He relates that one day, when he was scraping a copper plate with an iron chisel to rub out some spots, he heard a whistling noise, and found on looking, that the plate was covered with fine streaks at regular intervals, and that it was the production of these streaks which gave rise to the musical sound. As he moved his hand more quickly the note became more shrill, and the streaks closer together. Galileo knew that the sound was caused by vibrations of the particles of the air set in motion by the quivering of the metal, and he stated quite correctly that the reason he heard a higher note when the movement was more rapid, was, that a greater number of these vibrations struck on the drum of his ear in a certain space of time, thus causing it to vibrate more rapidly.

**Summary of the Science of the Sixteenth Century.**—And now we must pause for a moment in the history of Galileo, for his astronomical discoveries belong to the next century, and before entering upon them we must reckon up the advances which had been made in science during the past hundred years.

I think you will agree with me that at least one grand

step had been made when men learned to examine for themselves, and were no longer content merely to repeat like parrots what the Greeks had handed down to them. Copernicus had shown in astronomy, Vesalius in anatomy, and Galileo in mechanics, that it was no longer enough to quote passages from Ptolemy, Galen, and Aristotle; but men must take the trouble to examine the works of nature for themselves, if they wished really to understand the laws of the Great Creator.

This, in itself, was a great advance; but beyond this Copernicus, by his new system, had opened the way for grand astronomical discoveries, which you will see followed quickly in the next century, and Tycho, by his long and patient observations, had stored up facts for the use of those who came after him. In the same way Vesalius in anatomy, and Gesner and Cæsalpinus in natural history, had laid a foundation for the regular study of living beings, and had roughly sketched out a plan of classification. In the subject of light, Porta had invented the camera obscura, and explained the principle upon which it acts; and in doing this had made important discoveries about the action of light upon our eye, and the use of *lenses*, or convex and concave glasses, in magnifying objects. Lastly, Galileo had discovered the principle of the pendulum and the rate of falling bodies, and was now on the brink of the discovery of the telescope and all the wonders which it has revealed.

Meanwhile the sixteenth century closed with one very sad event, which must be mentioned here. Giordano Bruno, a Dominican friar, who was born about the year 1550, at Nola in Italy, was one of the first people who openly taught that the Copernican system was true. He ought to be peculiarly interesting to us, because he was the first person to teach in England that the earth moves round

the sun. But poor Bruno was a very plain outspoken man, and his bold language brought him to a sad but noble death. When people said he should not spread the Copernican system because it was contrary to the Bible, he answered boldly that the Bible was meant to teach men how to love God and live rightly, and not to settle questions of science. Most people now would say that Bruno was right, but the judges of the Inquisition did not think so, and were so alarmed at his opinions that they condemned him to death. In the year 1600, just as the century closed, Bruno was burnt at the stake in Rome as an atheist, partly because he insisted on repeating that the earth is not the centre of the universe, and that there may be other inhabited worlds besides ours.

---

*Chief Works consulted.*—Whewell's 'Inductive Sciences;' Brewster's 'Optics;' Brewster's 'Martyrs of Science,' 1874; 'Encyclopædia Britannica,' art. 'Astronomy;' Drinkwater's 'Life of Galileo;' Rossiter's 'Mechanics,' 1873; Cuvier, 'Histoire des Sciences Naturelles;' Baden Powell's 'Natural Philosophy.'

SCIENCE OF THE  
SEVENTEENTH CENTURY

*Chief Men of Science in the Seventeenth Century.*

	A. D.
Galileo . . . . .	1564-1642.
Kepler . . . . .	1571-1630.
Gassendi . . . . .	1592-1655.
Horrocks . . . . .	1619-1641.
Newton . . . . .	1642-1727.
Halley . . . . .	1656-1742.
Francis Bacon . . . . .	1561-1626.
Descartes . . . . .	1596-1650.
Snellius . . . . .	1591-1626.
Drebbel . . . . .	1572-1634.
Torricelli . . . . .	1608-1647.
Guericke . . . . .	1602-1686.
Boyle . . . . .	1626-1691.
Hooke . . . . .	1635-1702.
Huyghens . . . . .	1629-1695.
Roemer . . . . .	1644-1710.
Mayow . . . . .	1645-1679.
Beecher . . . . .	1625-1682.
Stahl . . . . .	1660-1734.
Steno . . . . .	1638-1687.
Scilla . . . . .	1639-1700.
Woodward . . . . .	1661-1727.
Harvey . . . . .	1578-1657.
Asellius . . . . .	1581-1626.
Rüdbeck . . . . .	1630-1702.
Malpighi . . . . .	1628-1694.
Leeuwenhoeck . . . . .	1632-1723.
Grew . . . . .	1628-1711.
Ray . . . . .	1628-1705.
Willughby . . . . .	1635-1672.



## CHAPTER XI.

## SCIENCE OF THE SEVENTEENTH CENTURY.

Astronomical Discoveries of Galileo—The Inquisition force him to deny the Movement of the Earth—Blindness and Death.

**Astronomical Discoveries of Galileo, 1609-1642.—**

The seventeenth century was not many years old when Galileo startled the world with discoveries such as had never been heard of before. He relates that when quite a young man he was so struck with an account given by some of his companions of a lecture on the Copernican theory, that he determined to study it, and he soon became convinced of its truth. Nevertheless, he saw how difficult it would be to *prove* that the earth moves round the sun, and not the sun round the earth.

When he went to Padua he gave a great deal of time to the study of astronomy, and had already made some remarkable observations, when one day, in the year 1609, being in Venice, he heard that a Dutch spectacle-maker had invented an instrument which made distant things appear close at hand.

This discovery, which Bacon and Porta had foreseen, was made at last almost by accident in Holland, by two spectacle-makers, Zacharias Jansen and Henry Lippershey. It is related that Jansen's children, when playing one day with two powerful magnifying glasses, happened to place

them, one behind the other in such a position that the weathercock of a church opposite the house seemed to them nearer and larger than usual, and their father, when he saw this, fixed the glasses on a board and gave them as a curiosity to Prince Maurice of Nassau. Whether this story be true or not, it is certain that in the year 1609, both Jansen and Lippershey made these rough telescopes as toys, though they did not know how useful they might be. But when Galileo heard of it he saw what valuable help it might afford in studying the heavens; and he set to work immediately, and soon succeeded in making a useful instrument.

A diagram of Galileo's telescope is given in Fig. 8. It was made on the same principle as opera-glasses are now, with one *convex* lens A B, which makes the rays from the object bend inwards or *converge*, and one *concave* lens C D, which makes them bend outwards or *diverge* before they come to a focus. In Fig. 8 one complete cone of rays is drawn coming from the point *m*, and the outline of another cone from the point *n*; there are really similar cones coming from all points along the arrow, but it is impossible to give these in a diagram. Each set of rays, as they fall on the lens A B, are made to *converge*, so that they would end in a point or focus, if they were not caught by the lens C D. But this lens having its surfaces curved inwards makes the rays bend outwards or *diverge* again, so that the end of the cone *m* reaches the eye in parallel lines at *m' m'* and the cone *n* at *n' n'*. From the eye, as you will remember (see p. 49), we follow them out in straight lines, and see the image at the angle M O N, so that it appears greatly magnified. If you look at any object through one tube of an opera-glass, and keep the other eye open so as to see the object at its natural distance, you can cover the real image with the magnified one, and thus see the magnifying power

of your glass. But when you do not compare them in this way you do not realise how much the object is enlarged, because it appears to come nearer, so as to be at some point between  $M N$  and  $o$ , and consequently to be less magnified. I must warn you that both in this diagram and

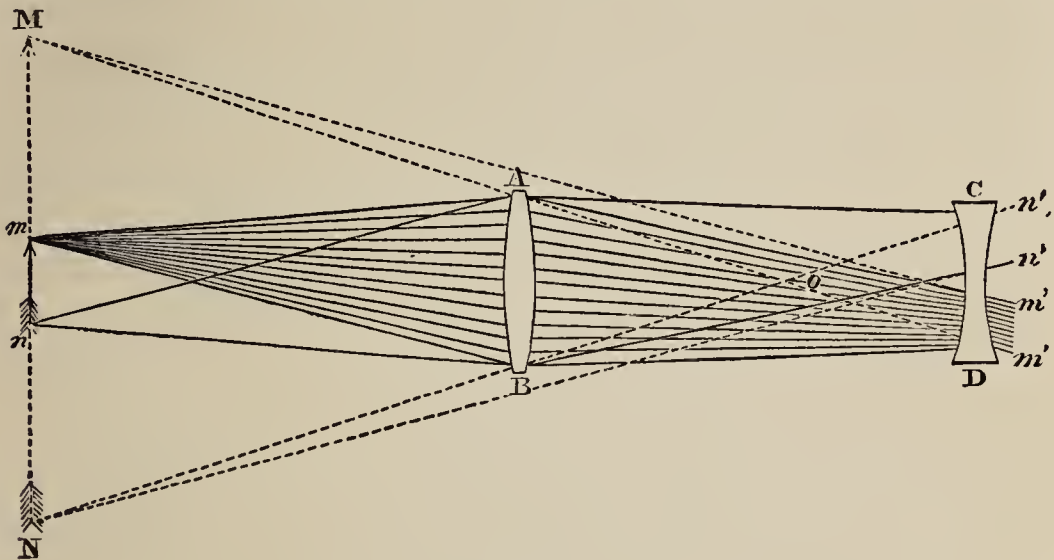

FIG. 8.

Galileo's Telescope.

$A B$ , Convex lens ;  $c D$ , concave lens next the eye ;  $m n$ , real arrow ;  $M N$ , apparent size of arrow ;  $m' n'$  and  $n' n'$ , end of the cones of rays  $m$  and  $n$  as they reach the eye ;  $M o N$ , angle at which the magnified arrow is seen.

the one at p. 95 the proportions are very much distorted, because a star or even a house would be an immense distance off as compared with the length of a telescope, whereas, in the drawing, the arrow must be placed as near to the lenses as they are to each other.

**Secondary Light of the Moon.**—Galileo's first telescope only magnified three times, that is, made an object three times larger ; but he made a second which magnified eight times, and then he turned it to the moon and began to examine the surface of that satellite. He saw the mountains of the moon, and the deep hollows buried in darkness, and the wide plains which he mistook for oceans. Then he noticed that curious light called the *secondary light*, which

may be seen on the dark side of the moon when only one quarter of it is bright and shining. Galileo discovered that this curious light is a reflection from the earth ; for you must know that we reflect the sun's light back to the moon just in the same way as the moon does back to us, and at the time when we see a new moon, the man in the moon (if there were such a person) would see a large full earth, and could wander about at night by *earth-light* as we do by moon-light. Look up at the new moon just about dusk in the evening, and if it is a clear night you will most likely be able to see a faint outline of the dark side of the moon, which is caused by our earth-light shining upon it.

**Jupiter's Moons.**—When Galileo had studied the moon and gazed with intense delight on the myriads of tiny stars in the Milky Way, he next turned his telescope to the planet Jupiter. To his great surprise he saw three small shining bodies like stars close to Jupiter, which were quite invisible to the naked eye. Two of them were on the east side of the planet and the other on the west. He waited eagerly for the second night, to see if Jupiter would move away from these stars, but he found them still together, only the two stars which had been on the east side had now moved round to the west, and they were nearer to each other than they had been before. He was quite puzzled as to how this could have happened, and watched and watched for many nights whenever the clouds would allow him ; and at last, on the fourth night after he had first seen them, he came to the conclusion that all three stars were moving round and round Jupiter, as the moon goes round our earth. A few nights later he found that there was a fourth star which went round with them ; and so Galileo discovered Jupiter's four moons in the year 1610.

This was the first fact in favour of the Copernican theory

which ordinary people could understand. The planets had till now been looked upon simply as lights in the sky moving round the earth; but now it could not be doubted that Jupiter at least was something more than this, for he had a system like our own, with four moons, to give him light by night, instead of one. Many people were terribly alarmed at the fact that our little earth should not be the central body in the heavens, because they had hitherto believed that the sun, moon, and stars had all been created for our use only, and this could scarcely be if our world was only one of many bodies moving round the sun. Some astronomers would not believe that Galileo had really seen Jupiter's moons; one was even so foolish as to refuse to look through the telescope, for fear he should see them.

**Phases of Venus.**—Galileo, however, now felt sure that his new instrument would help him to read wonderful truths in the beautiful universe of God, and he threw his whole heart and soul into this grand study. It was not long before he discovered another proof that the planets move round the sun and not round the earth. When he first saw the planet Venus through the telescope she was round, but happening to look at her one day, when she was almost between the earth and the sun, he saw her in the form of a crescent like a new moon. Struck by this, he continued to observe her night after night till she had made the whole journey round the sun, and he proved to himself that she went through the same changes as our moon, from a crescent shape to a full round face. This was just what she would be expected to do if she and we both travelled round the sun, whereas if she travelled round some fixed point between the earth and the sun, as was supposed by the Ptolemaic system, she could not exhibit these phases. Thus for the second time Galileo proved that the Copernican theory was the true one.

He next turned his attention to Saturn, and before the end of the year he had made out that this planet was not single, but had something on each side of it which he thought were two small stars. This was Saturn's ring, but Galileo's telescope was not powerful enough for him to see it clearly. In the year 1659 another famous astronomer, named Huyghens, saw the ring through a much better telescope, and described it (see Chapter XXI.)

**Sun-Spots.**—Galileo had now a great wish to go to Rome, so that he might show the new wonders he had discovered to the learned men who lived in that city. He accordingly carried his telescope there in 1611, and set it up in the Quirinal Garden. It was there that he first noticed the dark spots on the face of the sun, and observed that they were not always of the same shape, but that two or three would sometimes run into one, or that one would divide itself into three or four. These spots, which even now can only partly be explained by astronomers, were observed by several other men, especially by an English astronomer named Harriot, about the same time as by Galileo. But Galileo made a special use of his discovery, for he pointed out that the spots move round regularly in about twenty-eight days, disappearing on one side of the sun and re-appearing after some time on the other. This proved that the sun turns round upon its own axis in twenty-eight days.

**Galileo before the Inquisition.**—And now we come to the sad part of Galileo's history. He was well received in Rome, and the Pope even gave him a pension of a hundred crowns; but the judges of the Inquisition, who had caused Bruno to be burnt alive, became uneasy that Galileo should teach so many new things, and especially that he should prove that our earth was not the centre of everything, but a mere speck among the numberless stars and planets in the

heavens. They therefore sent for Galileo, in the year 1616, and threatened to punish him unless he would promise to hold his tongue about this new theory. Galileo, however, would not be silent; surrounded by his little circle of admiring pupils, he could not refrain from spreading wherever he went the grand facts he had discovered and the truths they taught. He was impatient that the world should not see as clearly as he did how glorious the universe is when rightly understood, and he often spoke and wrote sharply and sarcastically of those who would not listen to the truth.

At last, in 1632, he wrote a book called 'The System of the World of Galileo Galilei,' in which he clearly proved the truth of the Copernican theory, and alluded very angrily to the attempt which the Inquisition had made to force him to be silent. This book convinced many people, but at the same time it roused the anger of the judges of the Inquisition. They summoned Galileo (then an old man seventy years of age) to appear again before them; and this time they made him kneel, clothed in the sackcloth of a penitent, and swear with his hands upon the Gospels that 'it was not true that the earth moved round the sun, and that he would never again in words or writing spread this damnable heresy.' It is very sad to think that Galileo should thus swear to what he knew was a *lie*; but it is still more sad that men holding their power in the name of God should force him to choose between telling a lie or being put to torture or to death as Giordano Bruno had been. When Galileo rose from his knees it is said that he stamped his foot and whispered to a friend: '*E pur si muove*' ('Nevertheless it does move').

After a time he was allowed to go back to his own home, but never again to leave it without the Pope's permission. He went on with his studies, and made many useful observations; but in the year 1636 his sight began to

---

fail, and he soon became totally blind. At this time he wrote to an acquaintance these touching words: 'Alas! your dear friend and servant has become totally and irreparably blind. These heavens, this earth, this universe, which by wonderful observation I had enlarged a thousand times beyond the belief of past ages, are henceforth shrunk into the narrow space I myself occupy. So it pleases God, it shall therefore please me also.' He died January 28, 1642, in his seventy-eighth year; having accomplished his work. In spite of all opposition his discoveries had firmly established the truth of the Copernican system of the universe.

---

*Chief Works consulted.*—Brewster's 'Martyrs of Science;' Drinkwater's 'Life of Galileo;' Herschel's 'Astronomy;' Whewell's 'Inductive Sciences;' 'Encyclopædia Britannica,' art. 'Astronomy;' Baden Powell's 'Hist. of Natural Philosophy;' Ganot's 'Physics,' edited by Atkinson.



## CHAPTER XII.

## SCIENCE OF THE SEVENTEENTH CENTURY (CONTINUED).

Kepler the German Astronomer—His discoveries in Optics—His three laws—Comparison of the labours of Tycho, Galileo, and Kepler.

**Kepler, 1571-1630.**—While Galileo was occupied in discovering unknown worlds with his telescope, another famous astronomer, named Johannes Kepler, was working out three grand laws about the movements of the planets. John Kepler was born in 1571. His parents, though noble, were poor, and always in difficulties, but in spite of all obstacles he managed to educate himself, and even to take his degree at the University of Tübingen. In 1594 he was made Professor of Astronomy at Gratz, in Styria, and while there he began his attempts to discover the number, size, and orbits of the planets, but at first with no success. In 1597, when the Catholics at Gratz rose against the Protestants, Kepler, being a Protestant, was forced to leave the city, and would have been in great difficulties if his friend Tycho Brahe had not invited him to come to Prague as his assistant in the observatory. Here Kepler worked with Tycho at his astronomical tables, called the 'Rudolphine Tables,' in honour of the Emperor Rudolph; and when Tycho died, in 1601, he succeeded him as principal mathematician to the Emperor.

**Kepler on Optics, 1604.**—Although Kepler is chiefly known as an astronomer, his first work, published in 1604, was on Optics, and in it he points out most beautifully the true use of the different parts of the eye. He was much struck with Porta's idea that the eye is like a camera obscura, and he proved that the rays of light, after passing through the lens of the eye, form a real picture upside down on the fine network of nerves called the retina, at the back of the eye, and are then conveyed by the optic nerve to the brain. He also pointed out that the reason why we do not see things upside down is that since our mind follows out each ray in a straight line, the ray appears to cross back again on the lens of the eye, and we see them as if they had never been inverted. This is, however, a question still undecided by physiologists.

Kepler invented a much more powerful telescope than the one which Galileo had made. You will see by turning back to p. 87 that the fault of Galileo's telescope was that it made the rays *diverge* or bend outwards, just as they reached the eye, and in this way many of them passed outside and were lost. Kepler avoided this by using two convex lenses. In his telescope (see Fig. 9), the rays from the object  $m n$ , after converging on the lens  $A B$  comes to a focus at  $m' n'$  where they make a real image of the arrow upside down. If you could put a piece of thin transparent paper at the point  $m' n'$  in a telescope, you would see an inverted picture of the object upon it. The rays from this image falling on the lens  $C D$ , are again bent inwards, as by the ordinary magnifying glass (see p. 49), and thus by following them out in straight lines the eye sees a magnified arrow upside down at some point between  $C D$  and  $M N$ . Kepler's telescope is called the 'Astronomical telescope.' It has a much larger 'field of view' than Galileo's; that is, it enables

you to see over a larger space at one time ; but, on the other hand, it turns everything upside down. In making astronomical observations it is not of much importance which part of a star is uppermost ; but for terrestrial telescopes another lens has to be put in to bring the images back to their right positions, and since Kepler's time many other improvements have been made.

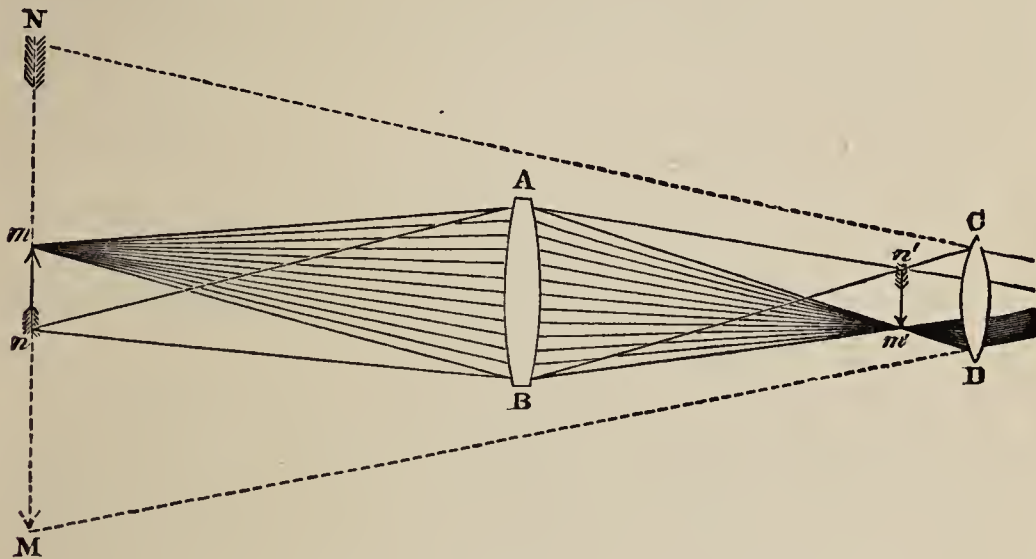

FIG. 9.

Kepler's Telescope.<sup>1</sup>

A B, Object-glass ; C D, eye-piece ;  $m n$ , real arrow ;  $m' n'$ , picture of the arrow formed at the focus of the rays ; M N, magnified arrow.

**Kepler's first Law, 1609.**—After Tycho Brahe's death Kepler went on working at the 'Rudolphine Tables,' and this led him to consider again the movements of the planets, and to try and find a theory to explain the path or orbit of the planet Mars. Mars is the planet which stands fourth from the sun ; Mercury is nearest to the sun, then comes Venus, then our earth, and then outside our earth is Mars. Tycho had noted in his tables the places at which the planet had been seen at certain periods ; and from these observa-

<sup>1</sup> This figure and also Fig. 8 were kindly drawn for me by Mr. A. R. Wallace.

tions Kepler calculated where it ought to arrive at other fixed times if it moved in a circle, as the earlier astronomers had supposed. But he found that it did not arrive there as computed, and he was so sure that Tycho's observations were exact that he said boldly, 'All the theories must be wrong if they do not agree with what Tycho saw.' So he puzzled on, trying one explanation after another, until at last he discovered three remarkable laws, by which the movements not only of Mars, but of all the other planets, are explained.

The first of these laws is that planets move round the sun in *ellipses* or *ovals*, and not in circles. You know that to draw a circle you put one leg of the compasses into a spot and draw the other leg round it, and the middle spot is called the centre or *focus*. But to draw an ellipse you must have two focuses or *foci*. To understand this, stick two pins a little distance apart in a piece of paper, and fasten a string to them by its two ends. Place a pencil upright in the string, so as to keep it tightly stretched, and draw the pencil round first on one side then on the other. You will then have an ellipse, and the two pin-holes will be the two foci. Draw the sun in one of the foci and a round globe on some part of the ellipse, and you will have a figure of the path of our earth or any of the planets round the sun. You will find that the farther you put the pins apart the flatter the ellipse will be. The path or orbit of the planet Mercury is much more elliptical than the orbit of the Earth. Another difference in the orbits of the planets is that they do not all lie in the same direction, though they all have the sun as one of their foci. For instance, in Fig. 10 the orbit of the planet A has the sun for one focus and the dot *c* for the other, while the orbit of the planet B has the sun for one focus and the dot *a'* for the other, and this makes the two

orbits lie in a different direction. Kepler's first law, then, was that *planets move in ellipses*.

### Kepler's Second Law,

1609.—His second law was about the rate at which planets move. He found from Tycho's tables that they all moved more quickly when they were near the sun than when they were far from it, and after an im-

mense number of calculations he found the following rule. If you could draw a line from the sun to any planet on the first day of each month of the year, you would enclose a number of spaces, such as *a, b, c, d*, etc., in Fig. 11, and each of these spaces would be the same size although not

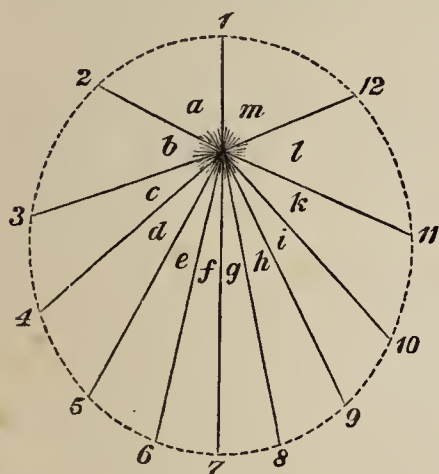

FIG. 11.

the same shape. For instance the planet, when travelling from 1 to 2 near the sun, would go very quickly and pass over a number of miles, while when travelling from 6 to 7 it would go slowly and pass over comparatively few miles. And yet the space *f* will be exactly the same size as the space *a*, only it will be long and thin instead

of short and broad. Kepler's second law, therefore, was that *planets describe equal areas about the sun in equal times*.

Not many months after Kepler published these two laws, he heard of Galileo's discoveries with his telescope—that Jupiter had four satellites, and that Venus had phases like

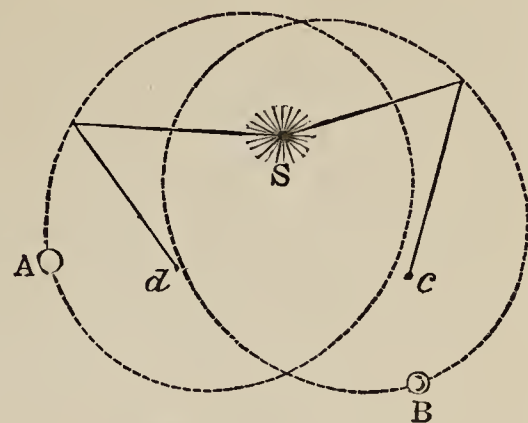

FIG. 10.

our moon, which proved that she moved round the sun. You may imagine how delighted he was to find the Copernican theory made so much more certain, and to see that the telescope was opening the way for so many new discoveries. 'Such a fit of wonder,' he said, 'seized me at this report, and I was thrown into such agitation, that between the joy of the friend who told me, my imagination, and the laughter of both, confounded as we were by such a novelty, we were hardly capable, he of speaking or I of listening.'

For many years after this Kepler was beset with troubles. The Emperor, being at war with his brother Matthias, had no money to spare for salaries. Kepler was thus harassed by poverty; his favourite son died of the small-pox, which the troops had brought into the city, and his wife died of grief not long afterwards. It was not till the year 1618, after he had re-married and had been rescued from his poverty by the new Emperor Matthias, that the unfortunate astronomer had energy and leisure to turn again to his favourite planets.

**Kepler's Third Law, 1618.**—It was in that year that he worked out with immense labour his *third* and most famous law—by which he showed how much longer the planets were going round the sun, according as they were farther off from it. This is difficult to understand, but we must try to form some idea of it. He did not know in figures how far each planet was from the sun, but he knew the proportion of their distances, as for example, that Mars is 4 times and Jupiter  $13\frac{1}{2}$  times farther off from the sun than Mercury, and he also knew how long each was in going round the sun, and from these two facts he worked the following rule.

If you take any two planets and cube their distances from the sun and then square the time each takes in going round

the sun, the two *squares* of the time will bear the same proportion to each other as do the two *cubes* of the distance. For instance, Mars is 4 times as far from the sun as Mercury, and therefore it is 8 times as long going round it, because the cube of 4 (or  $4 \times 4 \times 4$ ) is 64, and the square of 8 (or  $8 \times 8$ ) is also 64. Thus the *cube* of Mercury's distance as compared with that of Mars is 1 to 64, and the *square* of their periodic times of going round is also as 1 to 64. This law holds equally true of all the planets, and is expressed in scientific language thus: '*The squares of the periodic times of the planets are proportional to the cubes of their distances.*'

These three laws of Kepler were very great discoveries; especially the last one, which cost him years of labour and calculation. He was so astonished and delighted when he had proved it, that he told a friend he thought at first it must be only a happy dream that he should have succeeded at last after so many failures.

After this Kepler wrote and published many books, but he made no more important discoveries. The Rudolphine Tables were at last published in 1628, and Kepler received a gold chain from the Grand Duke of Tuscany for his services to Astronomy; but still he could not obtain the payment of his salary, and money difficulties pressed upon him. His anxiety threw him into a violent fever, and he died in 1630 at sixty years of age.

**Work done in Science by Tycho Brahe, Galileo, and Kepler.**—It will be instructive to notice here how very different these three astronomers, Tycho, Galileo, and Kepler were, and yet how they each did their own part to add to our knowledge. Tycho was a man who collected facts: his work was dry, and his tables were a mass of figures, such as most people would think very uninteresting; yet if

---

Tycho had not spent his life in this dry conscientious work, Kepler could never have discovered his laws. Galileo was a warm-hearted enthusiastic observer ; he loved the beauty of the heavens, and knew how to make others love it too ; every observation he made he told in popular language to the world, and taught people the truth of the Copernican theory by showing them plainly how they could prove it for themselves, if they chose to look at the heavens. Kepler was quite different from either Tycho or Galileo ; he was a mathematician, and worked everything out in his own brain by accurate methods. He took Tycho's observations, which he knew were true, and turned them this way and that way, working out now one calculation, now another, and always throwing them aside if they were not *exactly true*. He spent years over his attempts, but it was worth while, for he arrived at three true laws, which will remain for ever. There was only one point he had not reached ; he knew that his laws were true, but he did not know *why* they were true. This was left for Newton to demonstrate nearly fifty years afterwards.

---

*Chief Works consulted.*—Brewster's 'Martyrs of Science ;' Herschel's 'Astronomy ;' Denison's 'Astronomy without Mathematics ;' Airy's 'Popular Astronomy ;' Drinkwater's 'Life of Kepler ;' Baden Powell's 'History of Natural Philosophy.'



## CHAPTER XIII.

### SCIENCE OF THE SEVENTEENTH CENTURY (CONTINUED).

Francis Bacon, his 'Novum Organum'—Descartes—Willebrord Snellius discovers the Law of Refraction.

**Bacon's Influence upon Science.**—Although this book is a history of scientific discovery and not of philosophy, yet we must now mention in passing two philosophers who lived about this time, and whose writings had great influence upon science. These were Francis Bacon in England, and René Descartes in France.

Francis Bacon, commonly known as Lord Bacon, was born in London in 1561, and died in 1626. He was made Lord Chancellor of England in 1618, in the reign of James I., with the title of Lord Verulam and afterwards Viscount St. Alban's, and was a great political character. Bacon devoted much of his time to science, and, like his namesake Roger Bacon in the fifteenth century, he seems to have foreseen many of the discoveries which were afterwards made. But his most useful work was a book called the 'Novum Organum,' or 'New Method,' published in 1620, in which he sketched out very fully how science ought to be studied. He insisted that no knowledge can be real but that which is founded on experience, and that the only true way to cultivate science is to be quite certain of each step before going on farther, nor to be satisfied with any general law

until you have exhausted all the facts which it is supposed to explain.

For example, if you require to understand what *heat* is, and how it acts, you must not be satisfied, he says, by merely making a few experiments on the heat of the sun and that of fire, and trying from these to lay down some general rule of how heat works. 'No, you must examine it in the sun's rays both when they fall direct and when they are reflected; in fiery meteors, in lightning, in volcanoes, and in all kinds of flame; in heated solids, in hot springs, in boiling liquids, in steam and vapours, in bodies which retain heat, such as wool and fur; in bodies which you have held near the fire, and in bodies heated by rubbing; in sparks produced by friction, as at the axles of wheels; in the heating of damp grass, as in haystacks; in chemical changes, as when iron is dissolved by acids; in animals; in the effects of spirits of wine; in aromatics, as for example pepper, when you place it on your tongue. In fact, you must study every property of heat down to the action of very cold water, which makes your flesh glow when poured upon it. When you have made a list,' says Bacon, 'of all the conditions under which heat appears, or is modified, of the causes which produce it, and of the effects which it brings about, then you may begin to speak of its nature and its laws, and may perhaps have some clear and distinct ideas about it.'

You will see at once that this method of Bacon's had been followed already to a great extent by Copernicus, Tycho Brahe, Galileo, and Kepler; but Bacon was the first to insist upon it as the only rule to follow, and in doing this he rendered a great service to science.

**Descartes' Condemnation of Ignorant Assertion.**  
—René Descartes, by his philosophy, assisted science in another way. He was a Frenchman, born in Touraine in

1596, and he became one of the most famous philosophers of France. He wrote a great deal on science, especially on mathematics and geometry, and also on the nature of man; but the point which we have to notice here was his belief that to arrive at the *real truth* was the only thing worth living for.

You will remember how the men of science of the sixteenth century had thought it a sufficient answer to Vesalius or to Galileo to say that Galen or Aristotle had decided questions of anatomy and physics ages ago; and how the judges of the Inquisition thought they had crushed the Copernican theory when they made Galileo recant. *Authority* was the idol to which these people bowed down, and they considered it rank heresy to doubt anything which had been taught by their forefathers. But Descartes said, 'It is not true to say we know a thing simply because it has been told us. It is a duty to obey authority, to submit to the laws and religion of our country and parents, and in matters where we are not able to judge, it is wise to receive what is told us by those who know more than we do. But to *know* anything requires more than this, and unless the reasons for any belief are so clear to our minds that we cannot doubt them, we have no right to say, we *know* it to be *true*, but only that we have been told so.'

I think you can see how this rule of Descartes, that it is often more honest to *doubt* than to be *quite sure* without good grounds, would influence science. If scientific men in the time of Galileo, instead of saying 'We *know* that a heavy weight falls more quickly than a light one because Aristotle said so,' had said more modestly, 'We do not *know*, because we have never tried, but we think it probable Aristotle was right until some one shows us that he was mistaken;'—if they had gone to the Tower of Pisa in this spirit,

they would not have denied the truth of Galileo's experiment when it succeeded before their very eyes. And even now, in the present day, you will see that the greatest and best men who make the most discoveries, are those who are always willing to examine a new fact, even though it may contradict much that they have held before; and who never pretend to *know* for certain anything which they have not studied with sufficient care to be convinced of its truth.

Thus Bacon and Descartes both did great service to Science—Bacon by teaching that any true theory must be built up upon facts and careful experiments; Descartes by insisting that it is more honest to acknowledge we are ignorant, and to wait for more light, than to pretend to know that which we have not clearly proved.

**Snellius Discovers the Law of Refraction, 1621.—**

Among other things, Descartes wrote much upon Optics, and you will often see it stated that he discovered the law of refraction. This law had, however, been laid down before, in 1621, by a Dutch mathematician named Willebrord Snellius, and Descartes only stated it more clearly. You will remember that the Arab Alhazen first pointed out that rays of light are bent or refracted when they pass from a rarer into a denser substance or medium (see p. 47), as for instance from air into water; and that the denser the medium is into which they pass the more the rays are refracted. Vitellio and Kepler had measured some of the angles at which rays are refracted in water and glass, but they did not know of any *law* by which they could calculate how much any particular ray would be bent out of its course.

For instance, in Fig. 12, suppose  $w w$  to be the surface of water in a glass vessel, upon which the rays  $A$  and  $B$  fall at the point  $O$ , and are refracted  $A$  to  $A'$  and  $B$  to  $B'$ . It is evident that  $B$  is bent much more out of its course than  $A$ ,

as you will see at once if you lay a straight ruler from end to end of each ray; and if we were to draw other rays between these they would all be refracted at different angles, those being most bent which were farthest from the perpendicular.

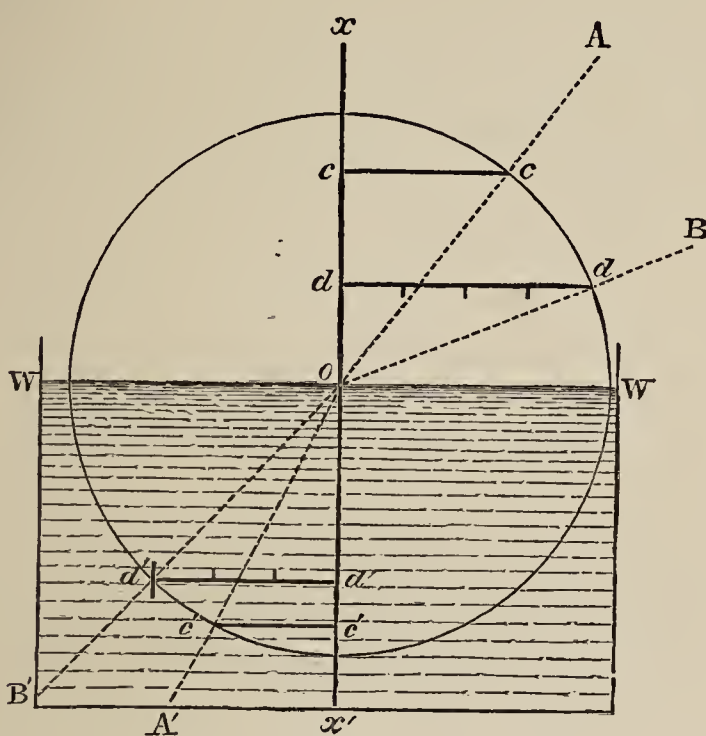

FIG. 12.

## Measurement of Refraction in Water.

w w, Water. A A', B B', Rays passing from air into water. c' c', Line from the ray A to the perpendicular  $x x'$ , in the water, three-fourths the length of c c from the ray A in the air. d' d', d d', Similar lines from the ray B.

Now in making telescopes it is very important to know how much each ray is refracted; and as the rays are infinite in number, it was impossible to know this unless some general rule could be found. Snellius set himself this task, and after a great number of very delicate experiments he arrived at a law which has proved to be always true. This law is best explained by the following experiment, which is not difficult to understand, although it is troublesome to perform it accurately.

Draw a circle on a black board with an upright line  $x x'$

through it, and then place the board upright in a vessel of water so that the surface of the water crosses the centre  $o$ . Then pass a ray of light through a tube so placed that the ray falls across the board in the direction  $A o$ ; it will then pass on through the water to some point  $A'$ . The line  $o A$  will now cut the circle at the point  $c$ , and the line  $o A'$  will cut it at  $c'$ . From these two points draw horizontal lines  $cc$  and  $c'c'$  on the board to the upright line  $xx'$ . Then if you compare the length of these two lines you will find that  $c'c'$  in the water is exactly three-fourths of  $cc$  in the air.

Again, if you throw the light from your tube in the direction  $B o$ , the result is the same. The length of  $d'd'$  in the water will again be three-fourths of  $dd$  in the air. And this is equally true of all rays passing from air into water. When a vertical line is drawn through the point where the ray falls on the water, *the two horizontal lines drawn to the place where the circle cuts the ray will always be in the same proportion, at whatever angle the ray strikes the water.* Therefore,  $\frac{3}{4}$ ths is said to be the *index of refraction* for water, meaning that every ray which passes from air into water will have these two horizontal lines in the proportion of 4 to 3. In passing from air into glass they would always be in the proportion of 3 to 2, and every different substance, such as ice, amber, diamond, etc., has its own index of refraction. These have been calculated, and tables made, from which you can learn at once what is the index of refraction for any particular substance.

It was this law of the proportion between the two horizontal lines in the air and in the denser substance which Snellius discovered, which is called after him 'Snell's law.' It is expressed in mathematical language, thus: '*The ratio between the sines of the incident and refracted rays is always the same for the same substance;*' sine being a mathematical

---

term for the measurement we have been making, which you will understand more fully when you have studied trigonometry.

---

*Chief Works consulted.*—Herschel's 'Study of Natural Philosophy;' Lewes's 'Biographical History of Philosophy;' Cuvier, 'Hist. des Sciences Naturelles;' Bacon, 'Novum Organum;' Huxley on 'Descartes,' Macmillan's Magazine; 'Encyclopædia Metropolitana,' art. 'Light;' Herschel's 'Familiar Lectures,' art. 'Light.'

## CHAPTER XIV.

## SCIENCE OF THE SEVENTEENTH CENTURY (CONTINUED).

Fabricius Aquapendente—Harvey discovers the circulation of the Blood  
—Gaspard Asellius—Pecquet—Rüdbeck.

**Harvey's Discovery of the Circulation of the Blood, 1619.**—In the year 1600, when Galileo and Kepler were still at the beginning of their discoveries, a young Englishman of two-and-twenty, named Harvey, who was born at Folkestone in 1578, went to Padua to study anatomy under the famous professor Fabricius Aquapendente. Although anatomists had by this time learnt a great deal about the bones and parts of a dead body, yet they were still very ignorant about the working of a living one. They knew that arteries throb, as for example the pulse in the wrist, which is an artery; and that veins (that is, the blue branching tubes which you can see under the skin in your hand and arm) contain blood and do not throb like the arteries; but they had no clear idea of the use of either arteries or veins. Vesalius had believed, like Aristotle, that the arteries contained chiefly a kind of air called 'vital spirits,' which they carried from the heart to all parts of the body; and that the blood was pumped backwards and forwards from the veins to the heart by the act of breathing. A Spaniard named Servetus, an Italian named Columbus, and the botanist Cæsalpinus, who all lived in the sixteenth century,



had indeed suggested that blood from the heart flowed through the lungs (or the part we breathe with), and came back again to the heart; and Cæsalpinus had even noticed that if you tie up a vein it swells on the side of the bandage away from the heart; but the notions of all these men were very vague and unsatisfactory.

The subject remained quite obscure till, while Harvey was studying at Padua, his master Fabricius discovered that many of our veins have curious valves inside them, made by the folding of the lining of the vein. These valves, which are just like little transparent pockets, lie open towards the heart so long as the blood is flowing in that direction; but if you press on a vein—in your arm for instance—and force the blood *away* from the heart towards the fingers, the valves close at once, and the vein swells up because the blood cannot flow on.

Fabricius thought that the use of these valves was merely to prevent the blood escaping too quickly into the branches of the vein; but this explanation did not satisfy Harvey, and he determined to try to discover which way the blood moved in the different vessels which held it. In order to do this he laid bare the artery of a living animal, say in its leg, and tied it round tight, so that the blood could not flow past the bandage. He found that the artery became very full of blood and throbbed strongly *above* the place where he had bound it, but in the lower part of the leg it did not throb at all. This proved to him that the blood in the *artery* was flowing *from* the heart to the leg of the animal, and was stopped on its way down by the bandage. He then tied up a vein in the same way, and this time the swelling was in the lower part of the leg, *below* where the vein was tied. Therefore it was clear that the blood in the *vein* was flowing *from* the leg *to* the heart, and was stopped from flow-

ing upwards by the bandage. When he tied an artery and a vein in the arm the same thing happened; the blood in the *artery* was flowing *towards* the hand, while in the *vein* it was flowing *from* the hand towards the heart.

This led Harvey to suspect that the blood is always making a continuous journey round and round, first out of the heart through the arteries to all parts of the body, and then back through the veins to the heart again. And now the use of the little valves became evident. While the blood flows, as it should do, towards the heart, they lie open and offer it no resistance, but directly anything drives it in the wrong direction they close at once, and prevent it from flowing backwards. The throbbing of the arteries was also explained by this theory, for the blood being pumped into them by a regular movement of the heart, they swell at each rush of blood, and contract again before the next, and so rise and fall in exact time with the beating of the heart.

Harvey also found that Cæsalpinus and his contemporaries had been right in suspecting that the blood makes a small circuit from the heart through the lungs and back again. We will try to understand all this with the assistance of a diagram, which, however, you must remember is only to help you, and not a real drawing of the parts. Starting from the left lower chamber *a* of the heart, the blood is pumped out of the left top corner of this chamber into an artery in the direction of the arrow 1. This artery soon divides into two branches, one going downwards by the arrow 2 to the lower part of the body, the other upwards by the arrow 2' to the arms and neck; and, after flowing into the different parts of the body, the blood in the *lower artery* returns by the *lower vein*, 5, 6, 7, while the blood of the *upper artery* is returning by the *upper vein* 4', and both streams pour into the right upper chamber of the heart, *b*.

The blood has now made one round, during which its colour has been changed from a bright scarlet to a dark purple, in consequence of its having parted with oxygen and gained carbonic acid in its passage through the different parts of the body. But it does not stop here. It escapes through a valve down into the lower chamber *c*; out of the right top corner of which it starts again in the direction of arrows 8 and 9, and passes through the lungs, returning by the lung-veins, or *pulmonary* veins as they are called, in the direction of arrow 10, back into the left top chamber of the heart *d*. During this second journey it is acted upon by the air in the lungs and rendered pure and bright again by taking in fresh oxygen. It then passes down from *d* into the chamber *a*, from which it first started, and the whole round begins again. The first journey of the blood round the whole body is called the *general circulation*, and the second journey through the lungs is called the *pulmonary circulation*; when Harvey had traced these two journeys he had proved the *double circulation of the blood*.

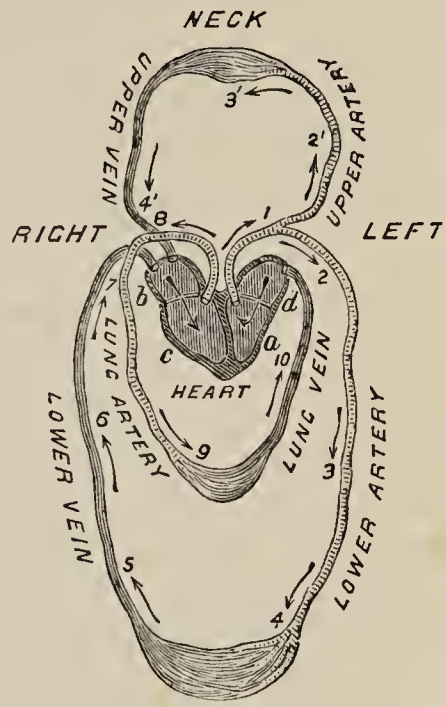

FIG. 13.

Diagram of Heart and Blood-vessels seen from the front.

*a c*, Lower chambers of the heart, called ventricles. *b d*, Upper chambers of the heart, called auricles. The arrows and numbers show the course of the blood.

Although this discovery as stated here appears very simple, yet it took Harvey nineteen years to trace the blood through all the channels of the body, before he felt quite certain that he had hit upon the truth. Meanwhile he had returned to London, and had been made physician at St.

Bartholomew's Hospital. Here he taught his theory in his Lectures of 1619, and at last published a small book on the circulation of the blood in 1628. Yet none of the older physicians would believe he was right, and Harvey told a friend that he lost many patients in consequence of his new doctrine. It is greatly to the credit of the unfortunate King Charles I., who was reigning at this time, and whose private physician Harvey was, that he gave him many opportunities of making physiological experiments on the animals in the royal parks, and took great interest in his discoveries. Harvey wrote several other valuable books, and traced the development of the chicken in the egg. He was of a very gentle and modest disposition, and disliked controversy so much that he could scarcely be persuaded to publish his later investigations when he found what disputes were occasioned by his great discovery of the circulation of the blood. He died in 1657, in his eightieth year.

**Discovery of the Vessels which carry Nourishment to the Blood, 1622-1649.**—Harvey's doctrine of the circulation of the blood was the real starting-point of *physiology*, or the science of living bodies, and when the true action of the arteries and veins was known, many other vessels of the body were soon better understood. The most important of these were the vessels which carry nourishment from all parts of the body to make fresh blood. In 1622 Gaspard Asellius, Professor of Anatomy at Pavia, saw a white fluid flowing from some thread-like tubes in the body of a dog which he was dissecting. This dog had been eating food just before he died, and Asellius found that the fluid came from the intestines and was the nourishing matter of the food. He called these fine tubes *lacteals*, because the fluid in them looked like milk. Some years later, in 1647, Jean Pecquet, an anatomist of Dieppe, discovered

that these *lacteals* empty themselves into a large tube called the *thoracic duct*, which carries the fluid into the principal vein, and so to the heart; and finally, in 1649, a Swede named Olaus Rüdbeck discovered an immense number of fine thread-like tubes running from all the principal parts of the body, and carrying nourishing matter to the thoracic duct, and so through the great vein to the heart. He called these tubes *lymphatics*; but in reality the lymphatics and lacteals are the same vessels, coming from different parts of the body and supplying the material for new blood. It is easy to understand that when physiologists knew not only how the blood circulates through the body, but also how a fresh supply of blood is being constantly provided, they had made a great step towards tracing out the workings of a living body.

---

*Chief Works consulted.*—Sprengel, 'Hist. de la Médecine,' 1815; Harvey's 'Anatomical Exercises,' 1673; Aikin's 'Biog. Mem. of Medicine till the Time of Harvey,' 1780; Huxley's 'Elementary Physiology; Carpenter's 'Physiology;' Kirke's 'Physiology;' Cuvier, 'Hist. des Sciences, etc; D'Orbigny, 'Dict. des Sciences.'

## CHAPTER XV.

## SCIENCE OF THE SEVENTEENTH CENTURY (CONTINUED).

Torricelli—Perrier—Pascal—Otto Guericke—Foundation of Royal Society of London and other Academies of Science.

**Torricelli's Invention of the Barometer, 1644.**—We must now turn to quite another subject on which new light was being thrown at this time. Among the many different mechanical experiments which Galileo made during his life, there had been one with a common pump which puzzled him very much, and which he had never been able to explain.

You know that if you put the mouth of a squirt in water and pull back the handle, the water rises up into the tube. That is to say, as soon as you leave a space inside the squirt quite empty without any air in it, the water rushes in. In the same way, water may be made to rise up a long tube standing with its open end in a pond or basin, by drawing up a tight-fitting stopper A, Fig. 14, called a piston, and so driving the air out at the top and leaving a vacuum inside the tube. But Galileo found that as soon as the water had risen up to the height of about 34 feet it would not mount any higher, even though the tube between the surface of the water c, and the piston A, had no air in it. He could not, however, find out why the water should stop rising just at this point, and it was not till after his death

that his friend and follower Torricelli (born 1608), who was a mathematical professor at Florence, hit upon the reason.

Torricelli asked himself, 'Why does the water rise in the tube at all? something must force it up.' Then it occurred to him that *air* must weigh something, and that it might be this weight on the open surface of the water which forced the water up the pump where there was no air pressing it down. To understand this you must picture to yourself all the air round our globe to be pressing down upon the surface of the earth. Now, so long as the tube also is full of air the surface of the water will all be equally pressed down, and so will remain at one level at *w B w*. But when the piston *A* is drawn up, it pushes the air above it out of the tube, and so lifts the weight off *B*, the water at which will immediately be forced up the tube by the pressure of the air on the water outside from *w* to *w*. This will go on till the water has risen about 34 feet to *C*, and then the column of water *C B* in the tube will press as heavily on the water at *B* as the air does on the water outside from *w* to *w*, so all the water *w B w* will again be equally pressed upon, and no further rise will take place in the tube.

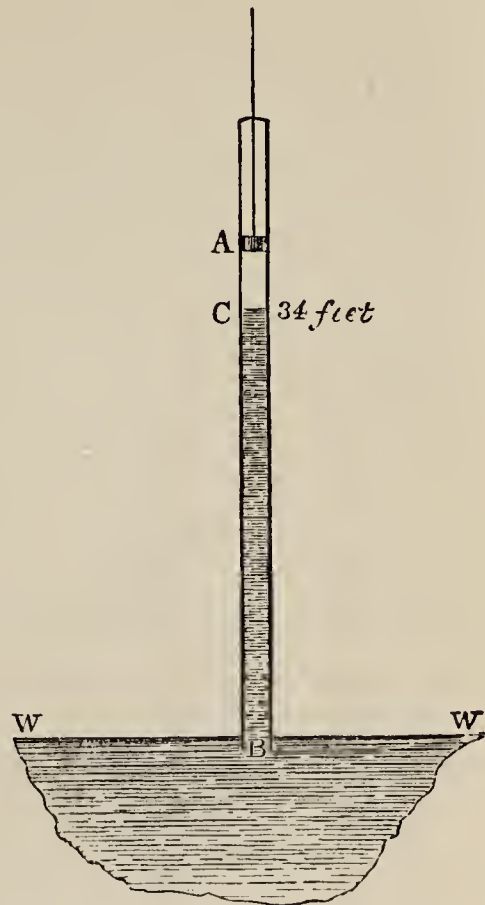

FIG. 14.

Section of a Suction-tube.

*A*, Tight-fitting piston. *C*, Greatest height to which the water will rise.  
*w B w*, Natural level of the water.

When Torricelli had come to this conclusion it occurred to him that if it was really the weight of the air which supported the column of water, it ought to lift mercury or quicksilver, which is fourteen times heavier, to one-fourteenth of the height. So he took some mercury, and filling a tube A, about 34 inches long, with it, he turned the tube upside down into a basin of mercury, which being open was

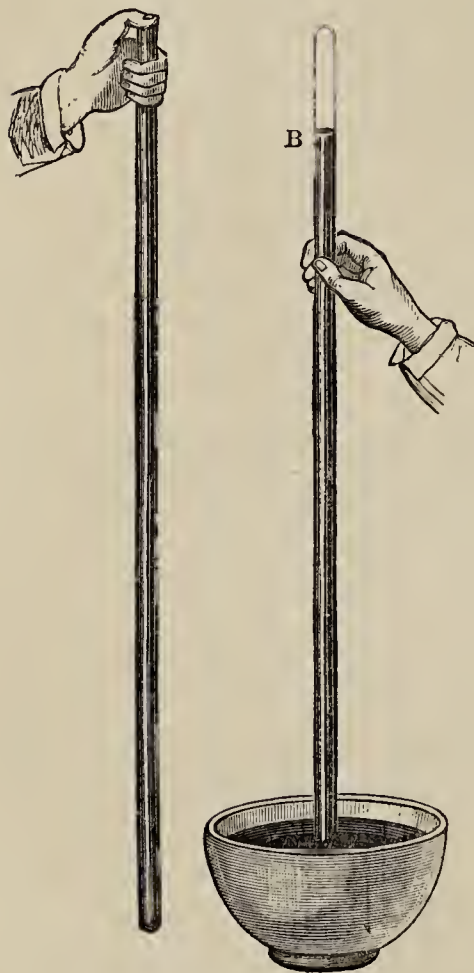

FIG. 15.

Torricelli's Experiment (Ganot).

under the pressure of the atmosphere. The mercury began at once to sink in the tube, and finally settled down at B, about 30 inches above that in the basin. This was a beautiful experiment, and proved almost to demonstration that the weight of ordinary air is sufficient to keep a column of mercury at a height of 30 inches in vacuum. He had now therefore made an instrument which would measure the weight of the air, and as our atmosphere varies in weight according as the weather is cold or hot, or damp or dry, a column of this kind would be higher when the air was heavy, and lower when it was light. He kept this apparatus

always in one place, and when the mercury rose above the 30 inches he concluded that the air outside was heavy; when, on the contrary, it sank, this showed him that the air was light. When once this was discovered it was easy to



mark off inches and parts of inches on the side of the tube, so as to reckon how much the mercury rose and fell each day.

This was the beginning of the *barometer*, by which we measure the weight of the atmosphere. It was a long time before people would believe that anything so invisible as air could affect the mercury, but this was at last clearly proved by a man named Perrier, who carried a barometer to the top of a mountain called the Puy de Dôme, in Auvergne. As the summit of a mountain reaches to a great height in the atmosphere, it has, of course, less air resting upon it than the valley below has, and so the mercury when carried to this height not being pressed so much up the tube, fell nearly 3 inches, and then rose again gradually as M. Perrier came down into the valley below, where there was a greater weight of air. This experiment, which was suggested by the famous French writer Pascal, confirmed Torricelli's theory, and proved beyond doubt that it was the weight of the air which caused the mercury to rise.

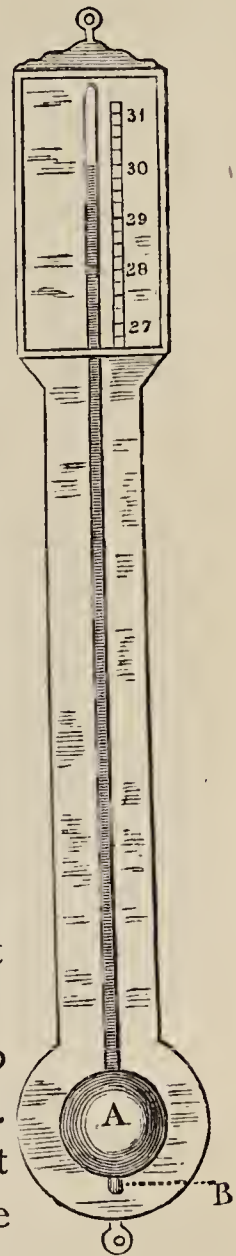

FIG. 16.

Ordinary upright Barometer.

A, Wood covering cup of mercury.  
B, Hole through which air acts.

If now, after reading this account, you go and look at an ordinary upright barometer (Fig. 16), you will perhaps be puzzled by finding it all enclosed in wood, and you will ask how the air can get to the mercury to press it down; but if you look carefully at the wooden box at the bottom, you will find a small hole in the wood, often having a small plug of paper in it to keep out the dust, and through this hole, even stuffed up as it is, the pressure of the air can act. The space between the top of the column of

mercury (B, Fig. 15) and the end of the tube is a *vacuum*, or a space with scarcely any air in it, and is still called a *Torricellian vacuum*.

**Invention of the Thermometer.**—The date of the invention of the thermometer (or instrument to measure heat) is so uncertain that it will be best to speak of it here in connection with the barometer. Galileo is said to have made the first thermometer, which was simply a tube with a bulb at the end standing upside down in a basin of water. The bulb was filled with air, and when heat was applied to it, it expanded and drove back the water in the tube. A few years afterwards a Dutchman named Drebbel made thermometers with spirits of wine in them, and finally, in 1670, mercury was used. Mercurial thermometers have the bulb and part of the tube filled with mercury, and the rest of the tube is quite empty, all the air being driven out by heating the mercury till it completely fills the tube, and then melting the end so as to close it. When the mercury cools it contracts and a vacuum is left above it. Afterwards, when the bulb of this thermometer is heated, the mercury expands and rises in the tube; when it is chilled it contracts and falls.

The thermometer was not of any great use till early in the eighteenth century, when three men, Fahrenheit, Celsius, and Réaumur, measured off the tube into degrees, so that the exact rise and fall could be known. Celsius and Réaumur took the melting point of ice as zero or  $0^{\circ}$  of their scale, but Fahrenheit took his from a mixture of snow and salt, which was the greatest cold he knew how to obtain. For this reason  $32^{\circ}$  is the freezing point of water in a Fahrenheit thermometer, and his other divisions are different from those of Celsius or Réaumur. Celsius's scale is the one now used all over the Continent, and scientific men

wish to introduce it into England, because it is so much more simple than Fahrenheit's. It is called 'centigrade,' or a hundred steps, because the tube is so divided that there are exactly  $100^{\circ}$  between the freezing and the boiling point.

**Otto Guericke invents the Air-pump, 1650.**—The Torricellian vacuum in the barometer was made, as we have seen, by simply filling a glass tube more than 30 inches long with mercury, and then turning it upside down into a basin of the same, so that the mercury in the tube fell to 30 inches, and an empty space was left at the top. But in 1650, a very few years after Torricelli's experiment, Otto Guericke, a magistrate of Magdeburg, in Prussia, made another step in advance and invented the *air-pump*, an apparatus by which air can be drawn out of a vessel, leaving it almost empty. Fig. 17 is the simplest kind of air-pump, and the way it works is not difficult to understand. At the bottom is a glass jar which has a round barrel or cylinder B B, fixed on the top of it. In the cylinder is a tight-fitting piston, *c c*, like the one in the suction-tube p. 115, only that this one has in it a valve or door, *d*. There is also another valve, *e*, at the place where the cylinder and glass jar meet, and both these valves open upwards. Now suppose we start with both valves shut and the piston *c c* down at the bottom of the cylinder resting on the valve, *e*. Then if we pull the piston gradually up, the valve *d* will be kept shut by the air outside pressing upon it, and so the piston will

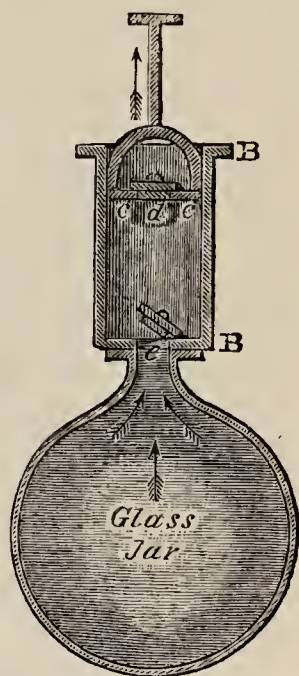

FIG. 17.

Air-pump (Knight).

B B, Cylinder.  
*c c*, Piston with valve.  
*d e*, Valves opening upwards.

drive the air between B and B out of the top of the cylinder. If the valve *e* remained also shut there would now be a vacuum, or space without air, in the cylinder B; but this will not be so, because the air in the jar below, being no longer kept down by air above it, will expand, and forcing up the valve *e* will fill the whole of the jar and the cylinder with expanded air.

Now bring down the piston *c c* again and observe what will happen. The thin air in the cylinder will be pressed down upon the valve *e* and will shut it, and then, not being able to get down into the jar, it will force up the valve *d* again, and escape out at the top. The piston will now be resting once more upon the valve *e*; but the glass jar will have much less air in it than it had at first, because it will have lost all that which went up into the cylinder and was pressed out at the top. You have only to repeat this process and more air still will be drawn out, and thus by moving the piston up and down you gradually empty the glass jar. You cannot get quite all the air out, because there must be enough left to push open the valve *e* when you pull the piston up, but you can go on till there is very little indeed. Air-pumps are now constructed, by which all but an infinitesimal quantity of air can be drawn out and a vacuum left which is almost perfect; but we are speaking of the one Guericke made, which was like the one I have described, only more complicated, and he worked it under water to make quite sure that no air should creep in at the cracks.

**The Experiment of the Magdeburg Hemispheres.**—The first experiment which Guericke made with his air-pump was to prove that the atmosphere round our earth is pressing down upon us heavily and equally in all directions. To do this he took two hollow metal hemispheres, like the

two halves of an orange with the inside taken out. These hemispheres fitted tightly together, so that no air could pass in or out when they were shut. Outside he fastened rings to hold by, so as to pull them apart, and at the end of one hemisphere he fixed a tap which fitted on to his air-pump. Now, as long as there was air inside the closed globe the two halves came apart quite easily; but when he had drawn out the air with the air-pump and turned off the tap so as to leave a vacuum inside, it required immense strength to drag the globe into two parts. This showed that the atmosphere was pressing heavily on every side of the globe, forcing the two halves firmly together, and as there was no air inside to resist this pressure, the person trying to separate them had to force back, as it were, the whole weight of the atmosphere to get them apart. As Guericke was burgomaster of Magdeburg, this experiment has always been called 'the experiment of the Magdeburg hemispheres.'

**The first Electrical Machine made by Guericke.**— You will remember that Gilbert had shown in 1600 that sulphur and many other bodies, when they are rubbed, will attract light substances. Since his time very little notice had been taken of this fact, till Guericke invented the first rough electrical machine in 1672. He made a globe of sulphur which turned in a wooden frame, and by pressing a cloth against it with his hand as it went round he caused the sulphur to become charged with electricity. His apparatus was very rough, but it led to better ones being made; and some years later, in 1740, a man named Hawksbee substituted a glass globe for the sulphur and a piece of silk for the cloth, and in this way electrical machines were made much like those we now use.

Guericke also discovered that bodies charged with the same kind of electricity repel each other. If you hang a

piece of paper, or better still, a pith ball *a*, upon a silk thread *b*, and hold near to it a piece of sealing-wax *c* rubbed with dry flannel, you will find that the ball will at first be attracted towards the sealing-wax as in 1, Fig. 18, but after a few moments it will be repelled and will draw back as in 2; nor will it approach the sealing-wax again till it has been near to some other body, and given the electricity it has received. Thus an electrical body, as Guericke pointed out, attracts one that is not electrified, but repels it again as soon as it has filled it with electricity like itself. He was

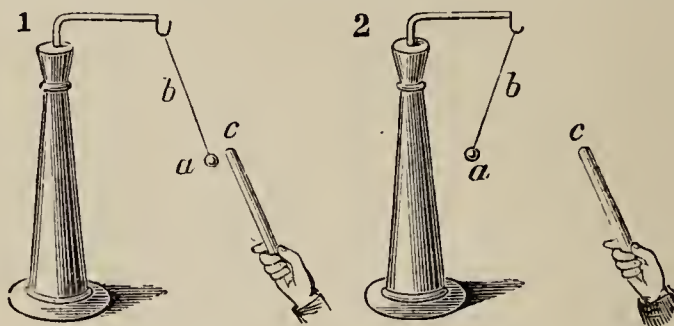

FIG. 18.

Pith-ball attracted and repelled by rubbed sealing-wax.

also the first to notice the spark of fire and crackling sound which are produced by electricity when it passes between two bodies which do not touch each other.

**Foundation of the Royal Society of London and other Academies of Science, 1645.**—We must now return to England, where about this time a society was founded, which, though it seemed insignificant at the time, had in the end a great influence upon science. In the year 1642 the unfortunate King Charles I. began that civil war with his people which ended in his being beheaded on January 30, 1649. During these years all England was in a state of turmoil and confusion, and in London especially the riots and disturbances made it almost impossible for quiet and studious people to live in peace. It was under these cir-

cumstances that a small group of scientific men, among whom were Robert Boyle, son of the Earl of Cork, and Dr. Hooke, an eminent English mathematician, began to meet together privately to try and forget public troubles in discussing science. They assembled first in London in 1645, but soon moved to Oxford to be out of the way of the constant riots, and continued to meet there till 1662, after the restoration of Charles II., when they settled in London and formed themselves into a regular Society under a charter from the king.

This was the beginning of the Royal Society of London, which has done so much for science during the last two hundred years, and which is still the leading scientific society of England. The following account of its early meetings is thus given by Dr. Wallis, one of the first members, 'Our business,' he says, 'was (precluding matters of theology and State affairs) to discourse and consider of philosophical enquiries, and such as related thereunto: as Physick, Anatomy, Geometry, Astronomy, Navigation, Staticks, Magneticks, Chymicks, Mechanicks, and Natural Experiments; with the state of these studies, and their cultivation at home and abroad. We then discoursed of the circulation of the blood, the valves in the veins, the *venæ lactæ*, the lymphatic vessels, the Copernican hypothesis, the nature of comets and new stars, the satellites of Jupiter, the oval shape (as it then appeared) of Saturn, the spots on the sun and its turning on its own axis, the inequalities and selenography of the moon, the several phases of Venus and Mercury, the improvement of telescopes and grinding of glasses for that purpose, the weight of the air, the possibility or impossibility of vacuities and Nature's abhorrence thereof, the Torricellian experiment in quicksilver, the descent of heavy bodies and the degrees of acceleration therein, with

divers other things of like nature, some of which were then but new discoveries, and others not so generally known and embraced as they now are; with other things appertaining to what hath been called the New Philosophy, which, from the times of Galileo at Florence and Sir Francis Bacon (Lord Verulam) in England, hath been much cultivated in Italy, France, Germany, and other parts abroad, as well as with us in England.'

How well we can picture from this account (written in 1696), the pleasure which this little group of men, weary of the quarrels and bloodshed of the times, felt in discussing and investigating those laws of nature which seem to bring us into the calm presence of an Almighty Unchanging Power far above the petty wranglings of man! The Royal Society has become, as I have said, one of the grandest scientific bodies in the world; but it has probably never held more earnest or enthusiastic meetings than in the small lodgings at Oxford where it first took its rise in the midst of civil war.

England was not long the only country which had a scientific society. Italy had already had two in the time of Galileo and Torricelli, but they had soon been broken up again. In Germany, the 'Imperial Academy of the Curious in Nature' was founded in 1662; and in 1666 the famous 'French Academy of Sciences' was legally established by the French Government in Paris.

All these societies were a great help in spreading the knowledge of scientific discoveries. Men who before were unable to publish what they knew, now sent or read their papers to those who could understand and appreciate them. The Royal Society began from the first to publish useful memoirs in their *Philosophical Transactions*; and in 1669 we find them bringing out the works of an Italian anatomist,



Malpighi, of whom we shall speak presently, and who sent to them works which he could not afford to publish in Italy. By this means the information scattered about the world was gathered together, and men were encouraged to seek out new truths when there was a chance of their being known and appreciated.

Among the earlier members of the Royal Society there were some whose discoveries we must now consider. These were Boyle and Hooke, whom we have already mentioned; John Mayow, whose experiments in chemistry are especially interesting; Ray, Grew, and Malpighi, naturalists and anatomists; the Dutch astronomer Huyghens; the English astronomer Halley, and last, but not least, England's great philosopher, Sir Isaac Newton.

---

*Chief Works consulted.*—Ganot's 'Physics,' 1873; Balfour Stewart on 'Heat,' 1871; Rossiter's 'Physics,' 1870; Baden Powell's 'History of Nat. Philosophy,' etc.; Cuvier, 'Histoire des Sciences,' etc.; Birch's 'Hist. of Royal Society;' Thomson's 'Hist. of Royal Society,' 1812.

## CHAPTER XVI.

## SCIENCE OF THE SEVENTEENTH CENTURY (CONTINUED).

Boyle—Hooke—John Mayow.

**Boyle's Law of the Compressibility of Gases, 1661.**

—The Hon. Robert Boyle, seventh son of the Earl of Cork, and one of the principal founders of the Royal Society, was born in 1626. He had very delicate health, and when quite young travelled much abroad and learned there a great deal about science even before he was eighteen years of age. He was deeply interested in Galileo's discoveries, and was in Florence when that great astronomer died in 1642.

After his return to England, when he was at Oxford, he read an account of Guericke's air-pump, and was so delighted with this new discovery that he set to work at once to make one without ever having seen the original. He succeeded so well, with the help of his friend and assistant Dr. Hooke, that his air-pump became famous, and many writers have by mistake given him the credit of being the inventor. We have seen, however, that Guericke was the first to hit upon this instrument; Boyle only improved it, and made with it many very valuable experiments upon the weight and nature of air. These are too many and lengthy for us to examine here; but there is one law about the compression of gases which you will find connected with Boyle's name in all books on physics, and which you ought

to understand. Boyle knew from Torricelli's experiment that the weight of the atmosphere upon the air close down to our earth, is about equal to the weight of 30 inches of mercury in a tube (see p. 116). Now he wished to find out how much air is *compressed*, or forced into a smaller space, when more weight is put upon it, and to discover this he devised the following experiment. He took a tube  $A^1$ , open at the long end and full of ordinary air, and by putting a little mercury into the tube and shaking it carefully till it settled at the bottom, he cut off a small quantity of air between  $b$  and  $c$ . This air was of course still under the usual weight of the atmosphere, which pressed down upon the mercury through the open end of the tube. But the mercury did not add to the weight because it stood at the same height on both sides of the tube, and so was evenly balanced.

He next added more mercury, till it stood 30 inches higher in the long end than in the short one (as seen in  $A^2$ ). The air between  $b$  and  $c$  was now pressed down twice as much as before, for it had the 30 inches of mercury weighing upon it, as well as the atmosphere, which equalled another 30 inches. Boyle found that this *double* pressure had squeezed it into *half* the space ( $b c$ , Fig.  $A^2$ ); in other

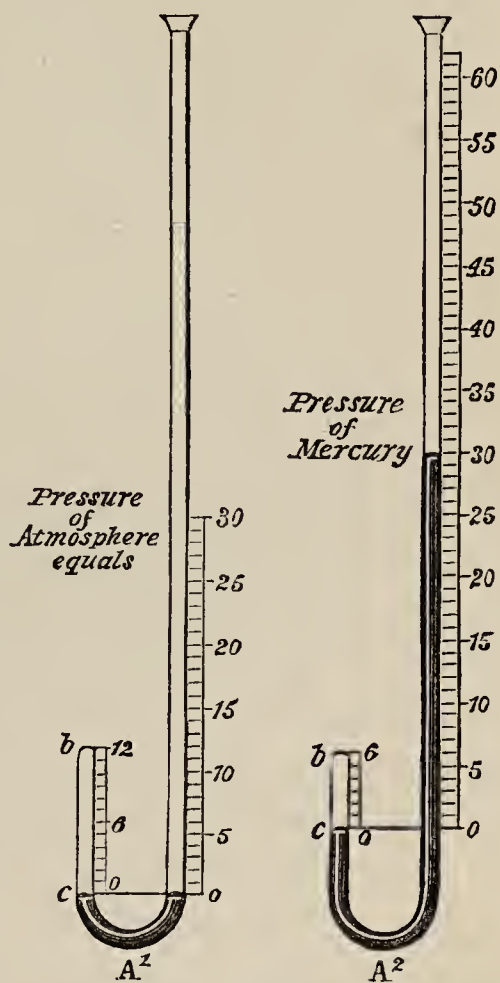

FIG. 19.

words, *by doubling the pressure he had halved the volume of the air.* He then poured in 30 inches more mercury, making the pressure *three times* as great as at first, and he found the air was now compressed into *one-third* of the space it had filled at first. And this he proved to be the law of compression of air and of all gases, that *the volume of a gas* (that is, the space it fills) *is decreased in proportion as the weight upon it is increased.* If you double the pressure you halve the volume; if you halve the pressure you double the volume.

This law of the compressibility of gases is known as *Boyle's Law*, or sometimes as *Marriotte's Law*, because a Frenchman named Marriotte also discovered it some years later without knowing that Boyle had done so. It is not always absolutely true, but we cannot stop to discuss the exceptions here; you will find them in books on physics and chemistry.

Boyle and Hooke both gave much time to the study of chemistry. Hooke published a theory in 1665 that air acts upon substances when they are heated, and so produces fire; for, said he, in making charcoal, although the wood is intensely heated and glows brightly, yet so long as the air is kept away it will not be consumed. Boyle also proved that a candle will not burn, nor animals breathe, without air. He found that when he put mice and sparrows into his air-pump, and then drew out the air, they died; and that flies, bees, and even worms, became insensible; while fish, though they lived longer than the mice, soon turned on their backs and ceased to live. He also put a bird under a glass vessel full of air, and it died after three-quarters of an hour. It was clear, therefore, that fresh air is necessary to life, and Boyle began to think that just as a candle-flame cannot be kept up without air, so there must be some vital fire in the heart which is extinguished when air is shut out from it.

This opinion he discussed at the Oxford meetings, and a young physician named John Mayow listened very eagerly, and then went home and set himself to try and find out what this strange power in the air could be, without which neither fire nor animals could exist.

**Mayow's Experiments on Respiration and Combustion, 1645-1679.**—John Mayow's private history is very short. He was born in Cornwall in 1645; he became a fellow of All Souls', Oxford, and practised as a physician in Bath; and finally he died at the house of an apothecary in York Street, Covent Garden, in 1679, before he was thirty-four years of age. This is all we know about his life; but he must have been a diligent worker and a real lover of science, for though he died so young he left behind him an account of a number of experiments and discoveries which entitled him to be called the greatest chemist of the seventeenth century. I wish we could go through all his experiments, for they form a most beautiful lesson of the earnest and painstaking way in which God's laws should be investigated. Mayow never made a careless experiment; he never thrust in his own guesses when it was possible to work out the truth; he went on patiently step by step, taking every care to avoid mistakes, and never resting till he had got to the bottom of his difficulties. Let us now take some of his experiments on *combustion*, or burning, and *respiration*, or breathing, and try and follow them as carefully as he did.

It seemed to him clear from the experiments of Boyle and Hooke that there must be something in the air which gave rise to flame and breath, and that this could only be a small part of the air, since a candle when put under a bell-glass went out long before all the air was gone. He first of all satisfied himself by experiments that this gas which burnt, and which he called *fire-air*, was not only in the

atmosphere, but existed in nitre, or saltpetre, and also in many acids; and then he set to work to discover how much of it there was in ordinary air. To do this he took a piece of camphor, with some tinder dipped in melted sulphur, and placed it on a little platform hung inside a bell-jar (see Fig. 20). He then lowered the bell-jar into a basin of water, having first put a siphon or bell-tube under the bell-jar to let out enough air for the water to rise. Then he took the tube out, leaving the water at the same height inside and outside the jar, while the rest of the jar above

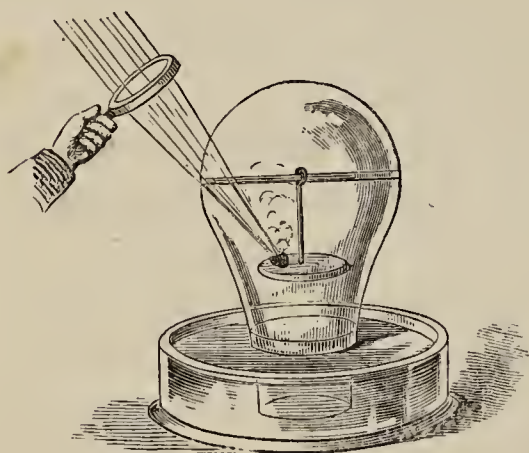

FIG. 20.

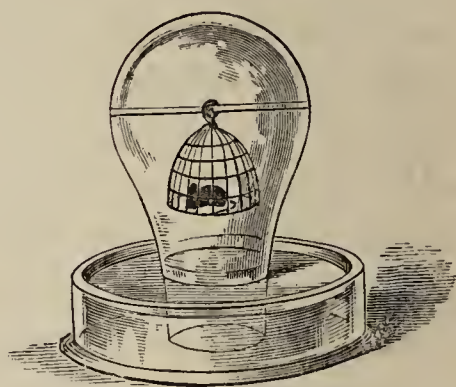

FIG. 21.

Mayow's experiments on combustion and respiration (Yeats).

the water was full of air. He now held up a burning-glass, and brought the sun's rays to a focus upon the camphor and tinder till it grew hot and burst into a flame. As it burnt he noticed that at first the water inside the jar sank down, because the air, being heated, expanded and took up more room. Then after a time the camphor ceased to burn, the jar cooled down, and the water rose again higher than before, till it stood *above* the water outside. The camphor was not all consumed, but when he tried to light it again he could not succeed. Why was this? 'Because,' said Mayow, 'there are no *fire-air* particles left in the jar to make the

camphor burn, and the using up of these particles has made the rest of the air shrink and take up less space.'

He now wished to compare burning with breathing, so he put a mouse in a cage and hung it inside the bell-jar, which he arranged over the water as before. Little by little as the mouse breathed the water crept up inside the jar, until when it had risen to a certain height the mouse drooped and died. It was clear, therefore, that animals in breathing use up some portion of the air. But is it the same portion which the flame uses? Many people would have jumped at this conclusion, but Mayow was not content till he had proved it by another experiment. He put a lighted candle and a mouse together inside the bell-jar. The water now rose much faster than before; the candle went out first, and then the mouse drooped as soon as the water had risen to the same height as in the other experiment. He was now certain that the candle and mouse both used up the same fire-air particles; but to make still more sure, he put a candle under a bell-jar where the air had been spoiled by breathing, and it went out directly.

His next step was to try whether air was lighter or heavier after the *fire-air* had been used up. To do this he put two mice into the jar, one at the top and the other at the bottom; the one at the top drooped and died, while the other was still breathing. This proved that the air which had lost its *fire-air* particles was lighter and rose to the top, so that the top mouse could no longer breathe. By these and a great many other experiments Mayow proved that air is made up of two portions—the one which supports flame and life being comparatively heavy; and the other light and useless for burning or breathing: this last was the largest portion. I want you to notice this particularly, because you will see by and by that Mayow had really discovered and described

two gases. The one which he called *fire-air* was *oxygen*, which was not known to other chemists for more than one hundred years later, and the other and lighter one is now called *nitrogen*.

Having now proved that an animal in breathing uses up the same part of the air which a candle does in burning, Mayow wanted next to know what this *fire-air* did inside the animal. Harvey, as you remember, had proved that the blood passes through the lungs and there meets the air which we draw in at each breath. Here then, said Mayow, the *fire-air* particles must come in contact with the blood, and, joining with it in the same way as they do with the fat of a candle, must cause the heat of the blood. If any one wants to prove this let him run fast. He will find that he is obliged to breath more quickly and draw more air into his lungs, which will soon make his blood hotter and move more quickly, till his whole body glows with warmth. But if this mixture of the air with the blood does really take place, the arteries into which blood has just flowed from the lungs and heart ought to be full of air; and this is easily proved to be the case by putting warm arterial blood under an air-pump, where as soon as the pressure of the outside air is taken off, innumerable bubbles rise out of the blood as fast as they can come.

In this way, by careful experiments and reasoning, Mayow succeeded in proving that *fire-air* (or oxygen) is the chief agent in *combustion* and *respiration*: If he had not died so young he might have become more known, and men might have studied his discoveries, which he published in 1674. Unfortunately, however, he did not live to spread his knowledge, and a false theory of combustion caused his work to be forgotten for many a long year.

**Theory of 'Phlogiston,' 1680-1723.**—This theory was



proposed by two very eminent chemists, John Joachim Becher (1625-1682) and Ernest Stahl (1660-1734). Ernest Stahl in particular was a man of great talent and perseverance, and he did a great deal for the study of chemistry by collecting a great number of facts about the way in which different substances combine together, and by arranging these facts into a system. But his theory of combustion was a very misleading one, although it had a germ of truth in it. Stahl imagined that all bodies which would burn contained an invisible substance which he called '*Phlogiston*,' and that when a body was burnt it gave up its phlogiston into the air, and could only regain it by taking it out of the air or some other substance. It would only confuse you to try and understand how this theory explained some of the facts of chemistry. You will see at once one which it did not explain, namely, why a body should grow heavier when it is burnt, as Geber, 1500 years before, had shown it does. It seemed, however, to answer so well in a great many problems, that chemists believed in it for nearly a hundred years, and Mayow's true explanation was forgotten till the eighteenth century, when fresh experiments brought it again to the front.

---

*Chief Works consulted.*—Brandé's '*Manual of Chemistry*'—Introduction; Rodwell's '*Birth of Chemistry*'; Yeats '*On Claims of Moderns to Discoveries in Chemistry and Physiology*,' 1798; Birch's '*Life of Boyle*,' 1744; Shaw's '*Philosophical Works of Boyle*,' 1725.

## CHAPTER XVII.

## SCIENCE OF THE SEVENTEENTH CENTURY (CONTINUED).

Malpighi—Leeuwenhœck—Grew—Ray and Willughby.

**Use of the Microscope by Malpighi, 1661.**—We have now fairly left behind us the first fifty years of the seventeenth century; indeed, the experiments of Boyle and Mayow were all made after 1650. But I wish especially to remind you in this place that we have just begun the second half of the century, because it will help you to remember an important study which began very quietly about this time, but which has in the end opened out to us an entirely new world of discovery. In the year 1609, at the beginning of the century, Galileo brought distant worlds into view by the use of the *telescope*; and in like manner in the year 1661, or about the middle of the century, Malpighi, by the use of the *microscope*, revealed the wonders of infinitely minute structures, or parts of living bodies; enabling men to see fibres, vessels, and germs, which were as much hidden before by their minuteness as the moons of Jupiter had been by their distance. It is not quite certain who invented the microscope (*μικρὸς*, *little*; *σκοπέω*, *I look*); but as the first which were made were only telescopes (see p. 95), with lenses of such a focus as to look at an object near instead of far off, any one may easily have hit upon the idea. The important point was the use made of them, and

this, as far as regards the structure of living beings, we owe to Malpighi.

Marcello Malpighi was born at Crevalcuore, near Bologna, in the year 1628; he became Professor of Medicine at the University of Bologna in 1656, and was early distinguished for his discoveries in Anatomy, made chiefly by the use of the microscope. It is not possible without a knowledge of anatomy, to understand thoroughly the structures which he described, but we may be able to form a general idea of the work he did.

One of his first experiments was the examination of the general circulation of the blood in the stomach of a frog, and he succeeded in demonstrating the fact that the *arteries* are connected with the *veins* by means of minute tubes called *capillaries*, thus proving beyond doubt the truth of Harvey's doctrine. His next work was to study the passage of the blood through the lungs (see p. 111), and to describe the air-cells from which the blood derives its oxygen. If you can get anyone to show you properly under the microscope a section of a frog's lung, you will see a number of round spaces bordered by a delicate partition; these are sections of air-cells, and round them you will see a network of minute tubes. Through these tubes or *capillaries* the blood flows in a living creature, and takes up oxygen from the air through the coverings or *membranes* of the air-cells and capillaries, giving back carbonic acid in exchange to be breathed out into the atmosphere. Malpighi was the first to point out these air-cells, and to describe the way in which the blood passes over them. After this he turned his attention to the tongue, and published in 1665 a careful description of all its nerves, vessels, and coverings. He also pointed out that the outside layer of the skin or *epidermis* of the negro is as white as yours or mine, and that the

colouring matter which gives him his dark colour is contained in a deeper layer just at the point where the *epidermis*

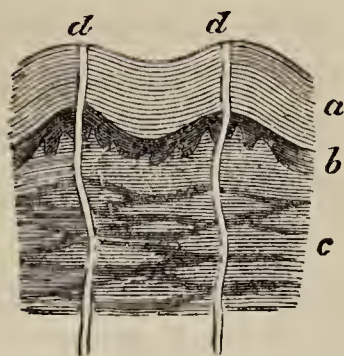

FIG. 22.

Section of the Skin (Huxley.)

*a*, Epidermis. *b*, Its deeper layer, or Malpighian layer. *c*, Upper part of the *dermis*, or true skin. *d d*, Perspiration ducts.

joins the *dermis* or real fibrous skin beneath (see Fig. 22.) This soft layer is still called the 'Malpighian layer,' and the different colours of the skins of animals are caused by little cells of colouring matter which lie buried in it.

After Malpighi had examined many other minute struc-

tures of the human body, he began next to study insects, and in 1669 he published a beautiful description of the silkworm. With his microscope he discovered the small holes or pores which are to be seen along both sides of the body of an insect, and he found that these pores were openings into minute air-tubes, which pass into every part of the insect's body, and form a breathing apparatus. He also described the peculiar vessels in which the silkworm secretes the juice from which its silk is made, and he traced the changes which the different parts of the worm undergo as it turns into the moth. In fact, he was the first man who attempted to trace out the anatomy of such small creatures as insects; a study to which men now often devote their whole lives.

But grand as Malpighi's discoveries were, a Dutchman named Leeuwenhœck (born 1632, died 1723) made the microscope tell even a more wonderful tale, for he detected in water and in the insides of animals those extremely minute beings which he called *animalcules*. He showed that a piece of the soft roe of the cod-fish not bigger than

an ordinary grain of sand might contain *ten thousand* of these living creatures. When such tiny beings as these could be seen and examined, I think you will acknowledge that I did not speak too strongly when I said that the microscope has opened out to us a new and marvellous world of life.

**Vegetable Anatomy, Grew and Malpighi, 1670.**—From insects Malpighi next turned to plants; and it is curious that at about the same time an English botanist named Nehemiah Grew (born 1628, died 1711), who was secretary to the Royal Society, also took up the same study, and the papers of the two men were laid before the Royal Society on the same day in 1670. Malpighi's complete work was afterwards published in 1674, and Grew's in 1682.

The investigations of these two men agreed in many remarkable points; they had both of them examined with great care the flesh (if we may call it so) of plants, and they described for the first time the tiny bags or cells of which every part of a plant is made, and which you may easily see for yourself if you put a very thin piece of the pulpy part of an apple, or better still, of the pith of elder under the microscope (see Fig. 23). They had also noticed the long tubes which lie among the woody fibres in the stringy or fibrous part of a plant and in the veins of the leaves, and Grew had pointed out quite truly that these tubes, which are called *vessels* or *ducts*, are composed of strings or cells which have grown together into one long cell or tube.

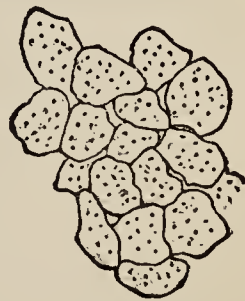

FIG. 23.

Cellular tissue from the pith of the elder (Oliver).

Grew also first saw those beautiful little *mouths* in the skin of the leaves called *stomates*, which open when the air

is damp, and serve for taking in and giving out air and moisture. To see these you must take a *very thin* piece of the skin of the under part of the leaf, and place it in water

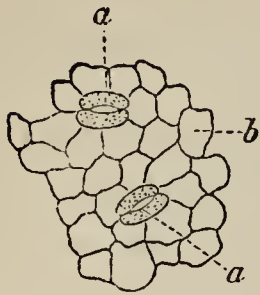

FIG. 24.

Piece of the outer skin taken from the under-side of an apple leaf. *a a*, Stomates. *b*, Cells of the skin (Carpenter).

under the microscope; you will see a number of very small roundish or oval spaces (*a*, Fig. 24), and if you watch carefully you will most likely see some of them open in the water. Grew discovered these *stomates* and pointed out their use. He also studied very carefully the way in which seeds begin to sprout; but on this point Malpighi did the most, for he watched under the microscope the whole process of the

growth of seeds, and described all the different states of the germ, comparing them to the growth of a chicken in the egg, and showing how much an egg and a seed resemble each other in many particulars.

By these few examples you can form an idea how much Grew and Malpighi did towards the study of the structure of plants or *Vegetable Anatomy*, a science which they may almost be said to have founded, and one which you may work at yourself with the help of a fairly good microscope and an elementary book on Botany. If you will do this with patience and care you will be well repaid; for some of the most beautiful and delicate of the contrivances of Nature lie hid in those frail flowers which we gather for their scent and beauty, and fling away without imagining what wonderful structures they can reveal to us even when dead and withered.

**Classification of Plants and Animals by Ray and Willughby, 1693-1705.**—We now come to the history of two friends, which is in itself a pleasure to dwell upon, even

if they had not both been great men ; but which becomes much more interesting when we remember that it was their love of the study of Nature which first brought them together, and which made them inseparable, not only in life, but in their works after death.

John Ray, one of the greatest botanists of the seventeenth century, was born near Braintree, in Essex, in the year 1628. Though only the son of a blacksmith, he received a good education at the grammar school of the town and went afterwards to Cambridge, where he remained as a tutor after he had taken his degree. Here one of his first pupils was a Mr. Francis Willughby, of Middleton Hall, in Warwickshire, a man seven years younger than himself, and belonging to quite a different rank in society. These two men, however, had one great interest in common—they were both passionately fond of Natural History, and spent all their spare time in studying it together.

They soon found that the descriptions and classifications of plants and animals which had been drawn up by earlier naturalists were very imperfect, and they formed the project of making a complete classification of all known plants and animals, describing them as far as they were able, and arranging them in groups according to their different characters. Willughby undertook the birds, beasts, and fishes, while Ray devoted himself chiefly to plants ; but they worked together in all the branches, and Ray, as we shall see, ended by doing far more than his share of the work.

From 1663 to 1666 the two friends travelled together over England, France, Germany, and Italy, making collections of plants and animals, and Willughby took a pleasure in using his wealth to add to the knowledge of his poorer companion. Soon after their return Ray was made a fellow of the Royal Society, and Willughby was not long before he

received the same honour. Willughby now married, and though Ray continued his travels alone, yet a great part of his time was spent at Middleton Hall, where the two friends made experiments upon sap in the trees and the way it flows.

In this way they worked together till, in 1672, Mr. Willughby died of a fever, leaving a sum of sixty pounds a year to Ray, and begging him to bring up his two little sons and to continue his works on Zoology, which he had left unfinished. The way in which Ray fulfilled these requests fully showed the affection which he felt for his lost friend. He brought up the boys till they were removed from his care by relations; and as to the works, he edited them with so much care and such a touching desire to give every credit to Willughby, that much of the work which must have been Ray's stands in his friend's name, and in fame, as in life, it is impossible to separate them.

We can only form a very general idea of the kind of classifications which Ray and Willughby adopted, for a mere list of classes would be neither interesting nor useful. The first book, which was on *Quadrupeds*, was published by Ray in 1693. He divided these first, as Aristotle had done, into *oviparous*, or those that are born from eggs, like frogs and lizards; and *viviparous*, or those which are born alive, like lambs and kittens. He then divided the viviparous quadrupeds into those which have the hoof all in one piece, like the horse, and those with a split hoof, like the ox and goat. Those with split hoofs he divided again according as they chewed the cud like the ox, or did not like the pig. Then came the animals whose hoofs are split into many parts, as the hippopotamus and rhinoceros; then those which have nails only in place of toes, as the elephant; then those which have toes but no separation between the fourth and



fifth toes, as the cat, dog, and mole ; and lastly, those which have the fifth finger, or toe, quite separate, as the monkeys. After this he divided them more fully, by their teeth, and thus made a very fair classification of quadrupeds.

The book upon Birds, which comes next in order, had already been published by Ray in 1677, four years after Willughby's death. In it birds were divided first into land-birds and water-birds, and were then classified by the shape of their beak and claws, and according as they fed upon flesh like the vulture, or upon fruit and seeds like the parrot. The water-birds were also divided into those which were long-legged, as the flamingo, or short-legged, as the duck, and according as the web between their toes was more or less complete.

The 'History of Fishes' is given as the joint work of Ray and Willughby ; the groups into which they divided them are nearly the same as those now used.

The 'History of Insects' was Ray's work, and was published by friends after his death, in the same way as he had published Willughby's. He divided insects into—first, those which undergo metamorphosis (that is, turn from the caterpillar into the moth), as the silkworm, and all moths and butterflies ; and second, those which do not change their form ; and then he subdivided them according to the number of their feet, the shape of their wings, and many other characters.

But Ray's greatest work was upon Plants, which he classified much more perfectly than Cæsalpinus had done. He divided them first into *imperfect plants*, or those whose flowers are invisible, as mosses or mushrooms ; and *perfect plants*, or those having visible flowers. The perfect plants he divided into two classes—first, the *dicotyledons*, or those whose seeds open out into *two* seed-leaves, like the wall-flower or the bean in which last you can see the two cotyle

dons very clearly as they form the two halves of the bean when you take off the outer skin; and secondly, the *monocotyledons*, or those whose seeds have only *one* large seed-leaf, like a grain of wheat. The dicotyledons he again divided into those having *simple* flowers, like the buttercup, and those whose flowers are *compound*, like the daisy; for if you pick a daisy to pieces you will find that the centre is made up of a number of little flowers, each of them perfect in itself and having its own green calyx and coloured corolla, and its own stamens and seed-vessel. Even the white strap-like rays round the daisy are each a separate though imperfect flower, therefore every daisy is a branch of little flowerets, or a *compound* flower. Ray went on next to class the *simple* flowers according to the number of seeds they bore, and the way in which the seeds were arranged in the seed-vessel. In this way he made a rough but complete classification of all the known plants. Linnæus, the great botanist of the eighteenth century, adopted many of Ray's divisions, which had meanwhile been made more perfect by Joseph Tournefort, a Frenchman, born at Aix, in Provence, in 1656.

Ray outlived his friend Willughby more than thirty years, and died in 1705 at the age of seventy-seven. His death brings us to the end of the Natural History of the seventeenth century, so far as we have been able to notice it. But I cannot too often insist upon the fact that the men here selected—Malpighi, Grew, Ray, and Willughby—are merely a few among an immense number of observers in the same line of study. I have picked out those whose work is most easily to be understood, and whose names are well-known; but I could have selected not four but forty others who ought to have been mentioned, in anything like a complete history of the period. We must, however, be content to catch here and there a glimpse of the advance that was

being made, always remembering that an almost inexhaustible store of further information remains behind when we have opportunity to seek for it.

---

*Chief Works consulted.*—Cuvier, 'Hist. des Sciences Naturelles ; Carpenter's 'Physiology ;' Sprengel, 'Histoire de la Médecine ;' Whewell's 'History of Inductive Sciences ;' Carpenter, 'On the Microscope ;' 'Memorial of John Ray,' E. Lankester, 1846 ; 'Life of Ray and Willughby,' Naturalists' Library, vol. xxxv. ; Lardner's 'Encyclopædia'—Classification of Animals.

## CHAPTER XVIII.

## SCIENCE OF THE SEVENTEENTH CENTURY (CONTINUED).

Newton—Fluxions and differential Calculus—Theory of Gravitation—Attraction varies inversely as the Squares of the Distance—The ‘Principia.’

**Newton, 1642.**—We must now leave the living creation and return to physical science, for, during all those years with which we have been occupied since the time of Galileo and Kepler, a boy had been growing up into manhood, who was to become one of the greatest men of science that England has ever known. In 1642, the same year in which Galileo died, a child was born at Woolsthorpe, near Grantham in Lincolnshire, who was so tiny that his mother said ‘she could put him into a quart mug.’ This tiny delicate baby was to become the great philosopher Newton.

We hear of him that he was at first very idle and inattentive at school, but, having been one day passed in the class by one of his schoolfellows, he determined to regain his place, and soon succeeded in rising to the head of them all. In his play hours, when the other boys were romping, he amused himself by making little mechanical toys, such as a water clock, a mill turned by a mouse, a carriage moved by the person who sat in it, and many other ingenious contrivances. When he was fifteen his mother sent for him home to manage the farm which belonged to their estate ;

but it was soon clear that he was of no use as a farmer, for though he tried hard to do his work, his mind was not in it, and he was only happy when he could settle down under a hedge with his book to study some difficult problem. At last one of his uncles, seeing how bent the boy was upon study, persuaded his mother to send him back to school and to college, where he soon passed all his companions in mathematics, and became a Fellow of Trinity College, Cambridge, in 1667. But even before this, in the year 1666, his busy mind had already begun to work out the three greatest discoveries of his life. In that year he discovered the remarkable mathematical process called the '*Method of Fluxions*,' which is almost the same as that now called the '*Differential Calculus*,' worked out about the same time by Leibnitz, a great German mathematician. In that year he also made the discoveries about *Light and Colour*, which we shall speak of by and by; and again in that year he first thought out the great *Theory of Gravitation*, which we must now consider.

**Theory of Gravitation, 1666.**—In the course of his astronomical studies, Newton had come across a problem which he could not solve. The problem was this. Why does the moon always move round the earth, and the planets round the sun? The natural thing is for a body to go straight on. If you roll a marble along the floor it moves on in a straight line, and if it were not stopped by the air and the floor, it would roll on for ever. *Why, then, should the bodies in the sky go round and round, and not straight forward?*

While Newton was still pondering over this question, the plague broke out in Cambridge in the year 1665, and he was forced to go back to Woolsthorpe. Here he was sitting one day in the garden, meditating as usual, when an

apple from the tree before him snapped from its stalk and fell to the ground. This attracted Newton's attention; he asked himself, *Why does the apple fall?* and the answer he found was, *Because the earth pulls it.* This was not quite a new thought, for many clever men before Newton had imagined that things were held down to the earth by a kind of force, but they had never made any use of the idea. Newton, on the contrary, seized upon it at once, and began to reason further. If the earth pulls the apple, said he, and not only the apple but things very high up in the air, why should it not pull the moon, and so keep it going round and round the earth instead of moving on in a straight line? And if the earth pulls the moon, may not the sun in the same way pull the earth and the planets, and so keep them going round and round with the sun as their centre, just as if they were all held to it by invisible strings?

You can understand this idea of Newton's by taking a ball with a piece of string fastened to it, and swinging it round. If you were to let the string go, the ball would fly off in a straight line, but as long as you hold it, it will go round and round you. The ball does not come to you, although the string pulls it, because the sideway pull of the string cannot check its motion onwards, but only alters its direction. This it does at every moment, causing it to move in a circle round you. In the same way the moon does not come to the earth, but goes on revolving round it.

Newton felt convinced that this guess was right, and that the *force of gravitation*, as he called it, kept the moon going round the earth, and the planets round the sun. But a mere guess is not enough in science, so he set to work to prove by very difficult calculations what the effect ought to be if it was true that the earth pulled or attracted the moon. To

make these calculations it was necessary to know exactly the distance from the centre of the earth to its surface, because the attraction would have to be reckoned as if all the mass of the earth were collected at the centre, and then as decreasing gradually till it reached the moon. Now the size of the earth was not accurately known, so Newton had to use the best measurement he could get, and to his great disappointment his calculations came out *wrong*. The moon in fact moved more slowly than it ought to do according to his theory. The difference was small, for the pull of the earth was only one-sixth greater than it should have been : but Newton was too cautious to neglect this want of agreement. He still believed his theory to be true, but he had no right to assume that it was, unless he could make his calculation agree with observation. So he put away his papers in a drawer and waited till he should find some way out of the difficulty.

This is one of many examples of the patience men must have who wish to make really great discoveries. Newton waited *sixteen years* before he solved the problem, or spoke to any one of the great thought in his mind. But more light came at last ; it was in 1666, when he was only twenty-four, that he saw the apple fall ; and it was in 1682 that he heard one day at the Royal Society that a Frenchman named Picart had measured the size of the earth very accurately, and had found that it was larger than had been supposed. Newton saw at once that this would alter all his calculations. Directly he heard it he went home, took out his papers, and set to work again with the new figures. Imagine his satisfaction when it came out perfectly right ! It is said that he was so agitated when he saw that it was going to succeed, that he was obliged to ask a friend to finish working out the calculation for him. His patience

was rewarded ; the attraction of the earth exactly agreed with the rate of movement of the moon, and he knew now that he had discovered the law which governed the motions of the heavenly bodies.

This law of Newton's is called the '*Law of Gravitation,*' and we must now try to understand what it is. Gravitation means the drawing of one thing towards another. All the objects upon our earth are held there by gravity, which pulls or attracts them towards the centre of the earth. If there were no such thing as gravity there would be nothing to prevent our chairs and tables, and even ourselves, from flying into space at the slightest impulse ; but they are all held to the earth by gravity, and if you dig a hole under them they fall directly nearer to the centre.

Now let us see how this attraction of gravitation affects the planets. Every one of the bodies in the heavens pulls or attracts all the other bodies, just in the same way as the earth attracts the apple on the tree. But as they are all moving rapidly along (like the ball swung round your head) they do not fall into each other, but the smaller bodies move round the larger ones which are near them, just as if they were fastened to them by invisible elastic threads. The smaller ones move round the larger one, because it is not only each body as a whole which pulls the other bodies, but every tiny atom of matter in each planet is pulling at all the atoms in all the other planets ; so the bigger a body is, and the more atoms it has in it, the more it will draw other bodies towards it. Our sun pulls the planets, and the planets pull the sun ; but our sun has 700 times more atoms in it than all the planets put together, and so it keeps them moving round it. In the same way our earth has eighty times more atoms in it than our moon, and so it keeps the moon moving round it.



In this way the force of gravity keeps all the different planets in their paths or orbits. It does not set them moving; some other force unknown to us first started them across the sky—gravitation is only the force which determines the *direction* in which they move.

It was a grand thing to have discovered this force, but it would have been of little value to Astronomy to know that the heavenly bodies attracted each other unless it could also be known *how much* influence they have upon each other. This also Newton worked out accurately. You will remember that Kepler had shown that planets move in ellipses, having the sun in one of the two foci (see Fig. 10, p. 97). Knowing this, Newton was able to calculate how much the sun attracts a planet when it is near, and how much when it is far off, so as to make it move in an ellipse; and he found that exactly as much as the *square of the distance increases*, so much the *attraction decreases*; that is, the attraction grows less and less at a regular rate as you go farther away from the body that is pulling.

For instance, suppose that at the point 1, Fig. 25, a planet was one million of miles away from the sun, and was being attracted with immense force. When it arrived at the point

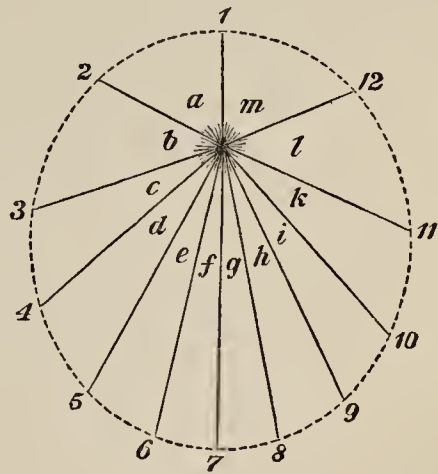

FIG. 25.

3 it would be about twice as far, or two millions of miles distant; and the square of 2 being 4 ( $2 \times 2 = 4$ ), the attraction of the sun at this point will be only one-fourth as much as it was at the point 1. At the point 7 the planet would be about three times as far, or three millions of miles from the sun, and as the square of 3 is 9 ( $3 \times 3 = 9$ ), the at-

traction here will only be  $\frac{1}{9}$ th of the attraction at the point 1. And so the calculation goes on; if the planet went 12 millions of miles off, the attraction would be  $\frac{1}{144}$  what it was at first, and at 92 millions of miles the attraction would be  $\frac{1}{8464}$ , so that when the planet is very far away the attraction becomes very slight indeed, but it will never entirely cease. In scientific language this law is expressed by the words, *The attraction varies inversely as the square of the distance.* When once this law was known, it explained in a most beautiful and complete way not only the three laws of Kepler, but all the complex movements of the heavenly bodies. These Newton worked out approximately by the help of his 'Method of Fluxions,' which enabled him to calculate all the varying rates at which the planets move in consequence of their mutual attraction; and he showed that whenever we know clearly the position and mass of all the bodies attracting a planet, the law of gravitation accounts for the direction in which it moves.

If you will consider for a moment what a labour it must be to calculate how much the different planets pull each other at different times—when they are near together and when they are far off, when they are near each other and near the sun, or near each other and far from the sun, in fact in all the different positions you can imagine—you may form some idea of the tremendous work he did. When he published his great book, the 'Principia,' in 1687, there were not more than eight people in the world who were able to understand the full meaning of his calculations and reasonings; and though his theory of gravitation was well received, and his name became one of the most renowned and honoured in the world, yet it was more than fifty years before his work was thoroughly appreciated.

It may therefore easily be imagined that it is not possible

to give a simple sketch of what is contained in the 'Principia;' but some idea may perhaps be formed of the grandeur of the law of gravitation from an enumeration of some of the problems which Newton explained by its action.

1. He explained those laws of motion which Galileo had proved by experiment, and showed that it is the force of gravity which causes the *weight* of bodies; and determines, when combined with other laws, the rate at which they fall, and the path they describe.

2. He worked out the specific gravity of the planets, showing, for example, that the matter of which Saturn is composed is about nine times lighter than the matter of our earth.

3. He showed how the attractions of the sun and of the moon cause the tides of the sea, and worked out accurately the reason of the spring and neap tides.

4. He proved that the earth could not be a perfect globe, and measured almost exactly how great the bulge at the equator and the flattening at the poles must be. And this he did entirely by calculation, for no measurements had then been made, to lead any one to doubt that the earth was a perfect globe.

5. He gave a complete explanation of the cause of the 'precession of the equinoxes,' the occurrence of which, as you will remember, Hipparchus had discovered (see p. 30).

6. He not only showed why the planets moved in ellipses while a line joining the sun and a planet cuts off equal areas in equal times; but he also accounted for many irregularities in these movements, arising from their mutual attractions, thus showing that gravitation explains not only the general laws but even apparent exceptions.

7. Of all bodies comets are apparently the most irregular, yet Newton calculated that they probably move in a

---

peculiar curve called a *parabola*, which is represented by the section of a cone cut parallel to one of its sloping sides, and since his time it has been proved that the motions of some comets can be sufficiently well explained by this theory, while others move in ordinary ellipses like the planets, and return periodically. These and many other problems of the universe Newton showed could all be referred to the action of gravitation; and he concluded his work with a grand description of the mechanism of the heavens, dwelling with deep reverence upon the thought of that Infinite Mind which gave rise to such a wonderful and complex machinery, working in perfect order.

---

*Chief Works consulted.*—Brewster's 'Life of Newton;' 'Lives of Eminent Persons'—Lib. of Useful Knowledge; Airy's 'Elementary Astronomy;' Airy, 'On Gravitation.'

## CHAPTER XIX.

## SCIENCE OF THE SEVENTEENTH CENTURY (CONTINUED).

Transits of Mercury and Venus—Gassendi—Horrocks—Halley—  
Explanation of Halley's Method.

**First Transits ever observed of Mercury and Venus, 1631-1639.**—We must now pause for a moment before passing on to Newton's discoveries in Optics, in order to mention a remarkable astronomical suggestion made about this time by the astronomer Halley (born 1656, died 1742), who was the friend and disciple of Newton.

You cannot fail to have heard and read something about the expeditions sent in December 1874 to all parts of the world to observe the Transit (or Passage) of Venus across the sun. The object of these observations was to measure the sun's distance from the earth; and Halley was the first to propose this method of measurement, in 1691, and to show how it might be accomplished.

It is well known that as the two planets Mercury and Venus are nearer to the sun than our earth is, they are constantly passing between us and it. But usually they pass either below or above the sun, and it is only rarely that they cross over the bright disc, so as to be seen through the telescope as a round black spot upon the sun's face. With Mercury this happens at intervals of from seven to thirteen years; but with Venus it is much more rare, for though two transits generally come together with an interval of only

eight years between them, yet after this there is a gap of more than a hundred years before another transit occurs.

After Kepler had finished the famous Rudolphine Tables he was able to use them to calculate when these *transits* would take place ; and he showed that both Mercury and Venus would cross the sun's disc on certain days in the year 1631. A French philosopher named Gassendi took advantage of this prediction, and managed to observe Mercury passing across the face of the sun on November 7, 1631. He was the first who ever observed a transit. With Venus he was not so fortunate, for the transit of that planet took place when it was night at Paris, and so Gassendi had no chance of observing it.

It was not long, however, before this too was seen. It must be remembered that two transits of Venus occur close together with only eight years between them. Now Kepler had imagined that in 1639 Venus would pass a little to the south of the sun, and so no transit would take place. A young Englishman, however, named Jeremiah Horrocks, only twenty years of age, after going carefully over Kepler's tables, felt convinced that there would be a transit, and he even calculated within a few minutes the time when Venus would enter upon the sun's face. Full of enthusiasm at the chance of seeing this grand sight, he wrote to a friend at a distance, begging him also to watch through the telescope at three o'clock on the afternoon of December 4, 1639. His expectations were not disappointed, for at fifteen minutes past three on that day the planet began to creep over the face of the sun. For twenty minutes Horrocks watched it, and then the sun set and he could see no more. He had been able to notice, however, that Venus was much smaller in comparison with the sun than had been formerly supposed. Horrocks and his friend Crabtree were the only people in

the whole world who saw this transit of Venus, the first one ever observed.

**1691. Halley suggests that the Sun's Distance may be measured by the Transit of Venus in 1761.**—This was all that was known about transits when Halley went to St. Helena in 1676 to study the stars of the Southern Hemisphere. Here he also observed a transit of Mercury, and after watching the small black spot travelling across the face of the sun, and noting the time it took in going from one side to the other, the idea occurred to him that it would be possible to learn the distance of the sun by measuring the path of a planet across its face. As Mercury, however, is very far from us, and near to the sun, it would not answer the purpose so well as Venus, which is much nearer the earth.

Halley knew that another transit of Venus would take place in 1761, and as he could not hope to live till then, he read a paper to the Royal Society in 1691, and another in 1716, beseeching the astronomers who should live after him not to let such an opportunity pass, and describing the way in which the observations should be made. It is this method which we must now try to understand as far as it is possible without mathematics.

First of all I must mention two facts which astronomers knew already. The proportion of the distances of the planets was ascertained, as you will remember, by Kepler (see p. 98). Therefore it was known that *Venus is* (in round numbers)  $2\frac{1}{2}$  *times as far from the sun as she is from the earth.* It was also known by the apparent size of the sun that *the sun's distance is about 108 times his diameter,* or, in other words, if you could measure the number of miles across the face of the sun and multiply that number by 108, it would give you the sun's distance from the earth.

Therefore the one point to be learnt was, *How many miles wide is the face of the sun?*

Now suppose you place a globe or any other object upon the table in the middle of the room, as at G, Fig. 26, and

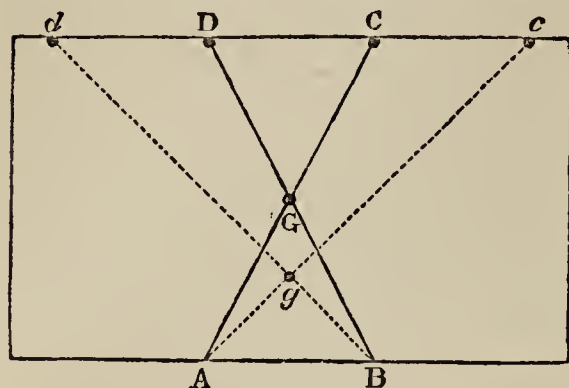

FIG. 26.

Diagram showing how the distance between the points D C and d c can be known without measuring them.

G, A globe half-way between D C and A B. g, A globe three times as far from D C as from A B.

place yourself at the point A. The globe will then hide from you (or eclipse) the point c on the opposite wall. Move your position to B, and the globe will then hide the point D. If the globe is (as at G) exactly half-way between you and the wall, the two points D and c will be the same distance apart as the points A and B. But if you move the globe to g, which is *three times* as far from the opposite wall as it is from you, then the points d and c will also be *three times* as far apart as the points A and B. So that by knowing how much farther the globe is from the wall than it is from you, you can tell accurately the distance between the points hidden without measuring them.

It is exactly in this way that Halley proposed to measure off a certain number of miles upon the face of the sun. We are able to learn accurately how many miles distant any two places are upon our globe. Suppose, therefore, that two men go to places 7200 miles apart, and each observes Venus at a particular moment upon the sun's face. Just as you, from two different positions, saw the globe cover two different points of the wall, so these men will see Venus against different points in the sun, as in Fig. 27; and since the distance between Venus and the sun is  $2\frac{1}{2}$  times her



distance from the earth, the two points will be  $2\frac{1}{2}$  times 7200 miles, that is 18,000 miles apart. Here, then, we

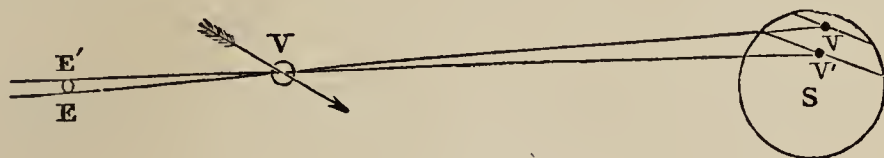

FIG. 27.

Venus as seen upon the sun by two observers, one at E' and one at E. (Proctor.)  
 s, The sun. v v', Appearance of Venus on the sun's face. Venus is travelling in the direction of the arrow.

have a certain number of miles measured off on the sun's face. But how are we to tell accurately what proportion this interval between the spots bears to the whole diameter of the sun?

By Halley's method the whole time that Venus takes in crossing the sun is used as the means of measurement. The observer at each of the two stations notes exactly the time when Venus begins to cross the face of the sun, and the moment when she passes off it again, and so reckons exactly how long she has taken in making the whole transit.

It was already known, from the rate at which Venus moves, exactly how long she would take in crossing the centre or widest part of the sun. We will call this time 6 hours, so as to use whole numbers. Now it is clear that in crossing a narrower part of the disc she will take less time. Suppose, therefore, that one man says she was exactly 5 hours crossing from A to B, Fig. 28, and the other that she was  $5\frac{1}{4}$  hours crossing

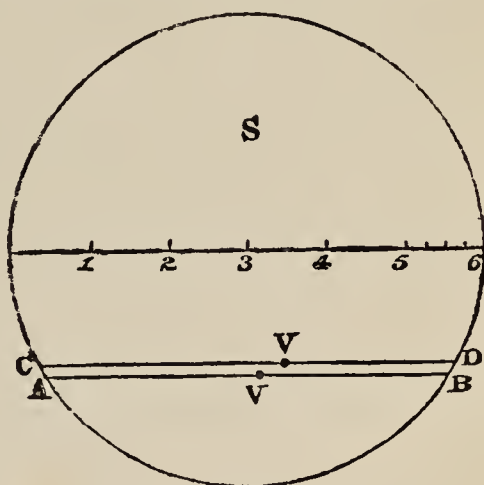

FIG. 28.

Transit of Venus.

s, Face of the sun. v, Venus. A B, Transit observed so as to occupy five hours. c D, Same transit observed so as to occupy five-and-a-quarter hours.

from c to d. This will give us the measurement necessary to lay down the position of the two transits on paper.

Draw a circle any size you please, and, ruling a line across the centre, divide it into six parts (as in Fig 28<sup>1</sup>), to represent the six hours which Venus would take in crossing the centre; each of those parts will then represent the distance which she travels in an hour;  $5\frac{1}{4}$  of these, therefore, will be the distance she travels in  $5\frac{1}{4}$  hours. Take this length in your compasses, and place it at any part of the circle where it will meet the edge at both ends, and in that position draw the line c d. Then take a second length of five parts only, and placing it below the other, rule the line A B parallel to c d. These two lines express the path of Venus, as observed by the two men, and we already know that the distance between them is  $2\frac{1}{2}$  times 7200, or 18,000 miles.

It is now easy to compare this interval with the sun's diameter. Suppose, for instance, that 47 such spaces will cover the whole diameter of the circle, as they would if the lines were drawn accurately in the observed positions, then  $18,000 \times 47$ , or 846,000 miles, would be the measure of the sun's diameter. Now, we saw (p. 155) that the sun's distance is 108 times his diameter; therefore  $846,000 \times 108$ , or 91,368,000 miles would, by these measurements, be the distance of the sun from the earth; and this is as near as we can arrive at the truth when taking whole numbers.

You will perhaps ask, if the measurement of the transit is such a simple process, why it takes months to make the proper calculations. But you must remember that in our

<sup>1</sup> It must be drawn very much larger to approach to anything like accuracy. This figure merely indicates the method.

description we have neglected all the difficulties which really occur. Our earth is not standing still as we have supposed it to be. It is not only moving along in its orbit, but it is turning round on its axis all the time, and this has to be very carefully considered in choosing stations for observing the transit, and allowed for in the results. Then, since our earth moves in an ellipse, we are not always at the same distance from the sun; this also has to be allowed for. Such simple difficulties as these you can understand, but there are a great number of others which make the calculations very complicated indeed. Therefore you must not imagine that you know all about the transit of Venus when you have read this description of Halley's method. If you have some general idea of the way by which the sun's distance is found out, you will have learnt more than many people; and you must wait till you have studied mathematics before you can expect to have a thorough knowledge of the matter.

You will be glad to hear that Halley's advice was not neglected. Several transit expeditions were sent out in 1761, and again in 1769, when the celebrated Captain Cook made a voyage to the Pacific Ocean for this purpose; and it is to correct these observations that no less than forty-six expeditions were sent out in 1874 from Europe and America, and again in 1882 all nations sent observers to favourable spots. Now that these two transits are over, there will not be another opportunity until December 2007. Halley made many other valuable astronomical observations. He was the first astronomer who foretold the return of a comet. Before his time it was thought that they went away and never came back again; but when the comet of 1682 appeared, Halley began to search for former records of comets and found that one had been seen about every

seventy-six years, reckoning backwards from 1682. Therefore he thought these must all be the same comet, and he foretold its return in 1758. It came as predicted, and has ever since been called 'Halley's comet.' Halley died in 1742, and with him ends the astronomy of the seventeenth century.

---

*Chief Works consulted.*—Proctor's 'Transits of Venus ;' Herschel's 'Astronomy ;' Denison's 'Astronomy without Mathematics ;' Airy's 'Popular Astronomy.'

## CHAPTER XX.

## SCIENCE OF THE SEVENTEENTH CENTURY (CONTINUED).

Newton on Dispersion of Light—Chester More Hall—Dispersive Power in Flint and Crown Glass—Newton on the Transmission of Sound—Last years of Newton's life.

**Newton publishes his Discovery of the Dispersion of Light, 1671.**—We must now return to Newton, and consider his third great discovery, which was about light. You will remember that he had to wait sixteen years between his first attempt to investigate the law of gravitation, and that new measurement of the earth which enabled him to prove the truth of his theory. During this time he had by no means been idle. He once said that the reason he had succeeded in making discoveries was that he gave all his attention to one subject at a time; from 1666 to 1671, when his papers on gravitation were quite laid aside, the subject to which he devoted himself was *Light*.

In the early part of the seventeenth century several people had tried to find out what it was that gave rise to different colours. An Italian Archbishop named Antonio de Dominis (died 1625) had given a better explanation of the rainbow than Roger Bacon had given before him; and Descartes had gone farther, and had pointed out that a ray of light seen through a clear, polished piece of glass, cut into the shape of a prism (see Fig. 29), is spread out into colours

exactly like the rainbow ; but no one had yet been able to say what was the cause of these different tints. Newton was the first to work this out in his usual accurate and painstaking way.

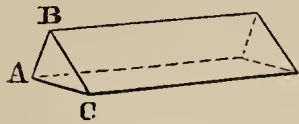

FIG. 29.  
Glass Prism.

He tells us that in 1666 he 'procured a triangular glass prism, to try therewith the celebrated phenomena of colours,' and in the very first experiment he was struck by a very curious fact. He had made a round hole F (Fig. 30),

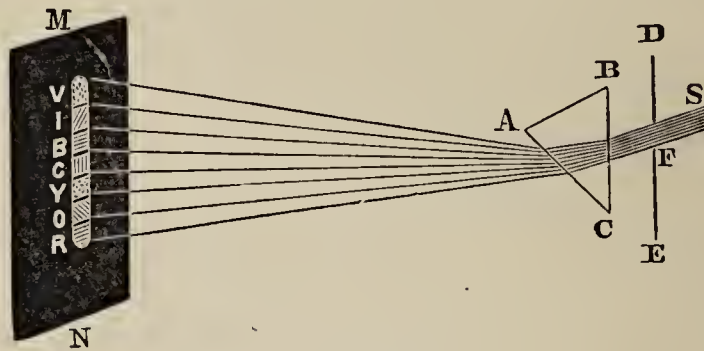

FIG 30.

Newton's first Experiment on Dispersion of Light.

D E, Window shutter. F, Round hole in it. A B C, Glass prism. M N, Wall on which the spectrum was thrown.

about one-third of an inch broad, in the window-shutter, D E, of a dark room, and placed close to it a glass prism, A B C, so as to refract the sun-light upwards towards the opposite wall of the room, M N, making the line of colours (red, orange, yellow, green, blue, indigo, and violet), which Descartes had pointed out, and which Newton called a *spectrum*, from *specto*, I behold.

While he was watching and admiring the beautiful colours, the thought struck him that it was curious the spectrum should be long instead of round. The rays of light come from the sun, which is *round*, therefore if they were all bent or refracted equally, there ought to be a *round* spot upon the wall ; instead of which it was long with rounded ends, like a sun drawn out lengthways. What

could be the reason of the rays falling into this long shape? At first he thought that it might be because some of them passed through a thinner part of the prism, and so were less refracted; but when he tested this by sending one ray through a thin part of the prism, and another through a thick part, he found that they were both equally spread out into a spectrum. Then he thought that there might be some flaw in the glass, and he took another prism; still, however, the spectrum remained long, as before. Next he considered whether the different angles at which the rays of the sun fell upon the prism had anything to do with it, but after calculating this mathematically he found the difference was too small to have any effect. Finally, he tried whether it was possible that the rays had been bent into curves in passing through the prism, but he found by measurement that this again was not the reason.

At last, after carefully proving that none of these explanations was the true one, he began to suspect that it must be something peculiar in the different coloured rays themselves which caused them to divide one from the other. To prove this he made the following experiment:—He made a hole  $F$ , in the shutter, as before, and passed the light through the prism,  $A B C$ , throwing the spectrum upon a screen,  $M N$ . He then pierced a tiny hole through the screen at the point  $g$ , Fig. 31; the hole in this board was so small that the rays of only one colour could pass through at a time. Newton first let a red ray pass through, so that it was bent by the prism,  $H I K$ , on the other side of the screen, and made a shaded red spot on the wall,  $O P$ , at  $R$ ; here he put a mark. He now moved the first prism,  $A B C$ , a little, so as to let the second, or orange ray pass through the hole  $g$ . This ray *fell upon exactly the same spot* of the second prism,  $H I K$ , as the red ray had done, but *it did not go to*

the same spot on the wall; it was more bent in passing through the prism, and made an orange spot at O, above the point R. By this Newton knew that an orange ray is more refracted in passing through a prism than a red ray is. He moved his prism, A B C, again, so as to let the yellow ray

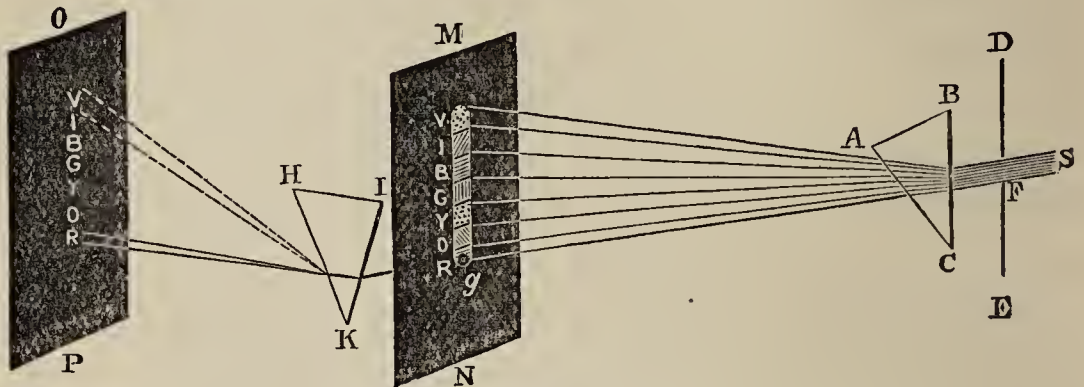

FIG. 31.

Diagram showing the Different Refraction of Rays of Different Colours.

D E, Shutter. F, Round hole. A B C, First prism. M N, Screen receiving the spectrum. g, Small hole through which the rays of only one colour can pass. H I K, Second prism refracting those rays.

through. This was still more bent, and fell above o on the point v. In this way he let all the different coloured rays pass through the hole, marking the points on which they fell, and he found that each ray was more bent than the last one, till he had marked out a second complete spectrum on the wall. Only the two extreme rays, red and violet, are traced out in Fig. 31, to avoid confusion.

This experiment proved clearly, 1st, that light is made up of differently coloured rays; and 2d, that these rays are differently refracted in passing through a prism. The red rays are least bent, and the violet ones most, while each of the other rays between these have their own course through the prism. I must warn you, however, not to think that there are exactly seven colours: there are really an infinite number, passing gradually into each other; Newton only divided them roughly into seven for convenience.



This spreading out of the different coloured rays is called the *dispersion of light*. I wish I could give you the many beautiful experiments which Newton made to prove it, but we have only room for one, which you can easily try for yourself, by which the different colours which make up the spectrum can be turned back again into white light. You will see at once that if it is true that white light can be divided up into colours, those same colours when reunited must make white. To show this Newton took a round card and painted upon it the seven colours, as pure as possible, five times over, like a spectrum five times repeated (A, Fig. 32), and then spun it round rapidly, so that the eye received the impression of all the seven colours at once

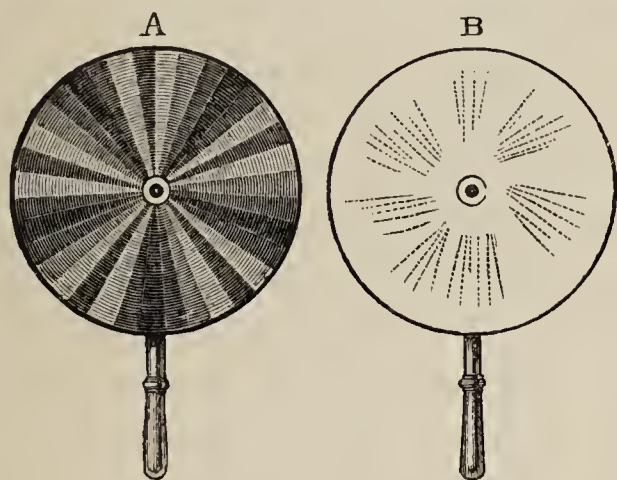

FIG. 32.

A, Newton's disc. B, Disc rotating.

(B, Fig. 32). If you do this you will see the card looks a dirty white, because the colours blend together just as they do in a ray of light. You will not get a pure white, because the artificial colours are not pure, and also because it is difficult to paint each colour in the proper proportion.

But now that we have proved that light is broken up into colours in passing through a denser medium, you may perhaps ask how it is that we do not see coloured rays whenever we look at the sun through glass or any other trans-

parent substance. The reason is that when the two sides of the glass are *parallel* (that is, lie always at the same distance from each other), the ray of light is bent just as much in going out from the glass into the air as it was when it came in from the air into the glass, and so it remains just as it was at first. When the two sides are not parallel, as in a rounded lens, colours *do appear* in the thin edges of the glass, and these used to be very troublesome in telescopes and microscopes. Newton thought that they could never be got rid of, for he did not know that light is spread out or *dispersed* more in one kind of glass than in another. But two years after his death, in 1729, Mr. Chester More Hall, of Essex, found that two kinds of glass (flint-glass and crown-glass) disperse light differently, so that when you put them together they correct each other, and the coloured rays at the edges are blended into white light. Telescopes and microscopes which are made in this way are called *achromatic* (from *a*, without ; *chroma*, colour). A patent for such instruments was taken out by a Mr. Dollond in 1757, and he probably invented them without having heard of Mr. Hall's discovery.

It would require a whole volume to give all Newton's investigations into the nature of light, and his experiments on the coloured rings of the soap-bubble and other transparent substances. His work on Optics was read before the Royal Society in 1671 and 1672, but the ideas were so new that many clever men, who should have known better, attacked him with a number of foolish and ignorant objections, till at last he told his friend Huyghens that he was almost sorry he had ever made them public.

**Newton explains how Sound is transmitted through the Air.**—There is yet another branch of physics, in which we owe much to Newton, namely, the study of *sound*. Pythagoras, Galileo, and Bacon had all taught that sound is

a vibration of the air which we feel when it acts upon the drum of our ear ; but none of these men had shown what kind of vibration this is. Newton was the first to suggest that it is caused by the particles of air moving backwards and forwards in the direction in which the sound travels ; the first particle being set in motion by some impulse given to it, and thus striking the second ; the second striking the third ; and so on until the particle nearest the drum of our ear hits it, causing it also to oscillate backwards and forwards, and producing in us the sensation of sound.

Many persons find it difficult to understand how waves of sound can travel for long distances, while the air-particles forming the waves only move to and fro within very small spaces. One of the best ways to realise how this can be is to watch a railway train which has been bumped by a luggage van being joined on to it. The first push to the stationary train will have been given by the van, which bumping against the first carriage, will cause it to bump against the second ; this in its turn will bump against the third, and the movement will thus pass on to the end of the line, so that if you were standing there the last carriage would knock you down. Yet each carriage will at the most have only stirred a foot or two from its place, and in the end they may all settle down nearly in their original positions. If you are standing by the side of the train which is being shunted, and watch it carefully, the reason of this will be clear. You will see that though the first carriage drives on the second, and the second the third, yet before many carriages have been so driven, the first carriage will have rebounded, and be moving away from the second, which, in its turn, will move away from the third ; so that while the fourth, fifth, and sixth carriages are sending on the bump and are huddled together, 1, 2, and 3 are moving

backwards and apart ; an instant later, 4, 5, and 6 will be drawing apart, in their turn, while 7, 8, and 9 will be close together, and so on to the end of the train. In this way a movement will pass along the whole line, every three or more carriages being huddled together, while the set behind them are separating, and this oscillation will go on until the train comes to rest. A movement exactly similar to this takes place in a wave of sound. The particles of air set in motion at one end are pushed forward, strike, and rebound just as the carriages do, and thus the movement is passed along the whole mass of air, while the particles themselves are oscillating backwards and forwards within very narrow limits. This movement, if visible, would have the appearance of Fig. 33 : a *condensation* or crowding of the particles *a*, and a *rarefaction* or separation of the particles *b*, occurring

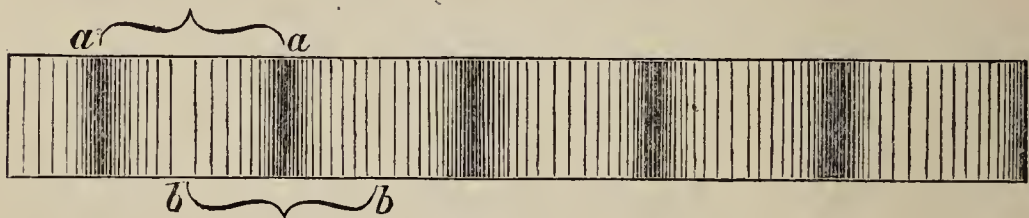

FIG. 33.

Waves of Sound. *a*, A condensation ; *b*, a rarefaction. From *a* to *a*, or *b* to *b*, is called a sound-wave, and varies in length according to the depth or shrillness of the sound.

one after the other. The space from one condensation to another, or from one rarefaction to another, is called a *wave of sound*.

In one way, however, sound travels somewhat differently to the wave of movement along a train. The carriages of a train are confined in one straight line, just as air particles would be if they moved in a tube ; but in the open air the particles can move in all directions, and therefore sound does not only travel in one straight line, but spreads out in all directions in expanding spheres, unless it meets with some

obstacle by which the movement is driven back, and then the sound is reflected. Newton not only pointed out *how* sound travels, he also attempted to ascertain *at what rate* it travels, and he showed that the more elastic and less dense air is, the more rapidly it will convey sound. A very elastic substance, in the proper sense of the word, is one which will spring back to its original shape whenever it is set free, just as a steel spring does. Now in the case of the train, if it happen to be composed of a set of heavy trucks with no springs between them, they will move sluggishly, and the waves of compression and rarefaction will take place but slowly. But if the train be composed of light carriages with springs at the end of the buffers, then each carriage will rebound much more quickly, both because it is lighter, and because the elasticity of the springs will help the rebound. Now when air is heated, if it cannot expand it becomes more elastic, and if it can expand it becomes lighter than when it is colder, and therefore in either case sound will travel more quickly along warm air than along cold.

Newton tried to calculate the rate at which sound travels, but he did not know that the mere fact of the sound-wave passing along makes the air hotter and therefore more elastic, so his results were not strictly accurate. We know now that in air which has a temperature of  $32^{\circ}$  Fahr., sound travels at the rate of 1090 feet per second, while in air of the ordinary temperature of  $52^{\circ}$  Fahr., it travels at the rate of 1112 feet per second.

Newton's account of his experiments on sound are to be found in the second Book of his 'Principia.' After this great work was published, in 1687, he next turned his attention to chemistry, but unfortunately all the results of his labour in this science were destroyed by an

accident. One day when he was in chapel his pet dog Diamond turned over a lighted taper, which set fire to all the papers on which his work was written. When he returned and found the charred heap it is said that he merely exclaimed, 'O Diamond, Diamond! thou little thinkest the mischief thou hast done!' but his grief at the loss of his work affected his brain, and though he recovered and lived another forty years, publishing many editions of his works, yet he never made any more great discoveries.

Newton received many honours in his old age : in 1699 he was appointed Master of the Mint, and a member of the French Royal Academy of Sciences ; in 1703 he was made President of the Royal Society, and in 1705 he was knighted by Queen Anne. Like all truly great men, he was modest as to his own abilities, and always willing to be taught by others. He felt so strongly how much we have still to learn about the Universe, that he considered his own discoveries as very trifling indeed. A short time before his death he said of himself, 'I know not what the world may think of my labours ; but to myself I seem to have been only like a boy playing on the sea-shore, and diverting myself in now and then finding a smoother pebble or a prettier shell than ordinary, whilst the great ocean of truth lay all undiscovered before me.' Yet this man who spoke so humbly was the discoverer of the greatest and most universal law known to mankind ! He loved to seek out new laws, but he was more anxious to collect facts and to make sure that he was right, than eager to publish his conclusions. It was the *truth* he loved, and not the fame which it brought. His patience and perseverance were unbounded ; he was never in a hurry, but turned a subject over and over in his mind for years together, seizing upon every new light shed upon it, and waiting patiently for more. And through all his

---

labours he looked reverently up to the One Great Light whose guiding power he loved to trace and to acknowledge in all the wonders of the universe. He died in 1727 at eighty-five years of age, and was buried in Westminster Abbey, his pall being borne by the first nobles of the land.

---

*Chief Works consulted.* — Newton's 'Optics,' 1721; Ganot's 'Physics;' Rossiter's 'Physics;' Brewster's 'Encyclopædia,' art. 'Optics;' Herschel's 'Familiar Lectures;' Newton's 'Principia,' Book II.; Brewster's 'Life of Newton.'

## CHAPTER XXI.

## SCIENCE OF THE SEVENTEENTH CENTURY (CONTINUED).

Roemer—Velocity of Light—Huyghens—Cycloidal Pendulum—Corpuscular and Undulatory Theories of Light—Refraction—Double Refraction.

**Olaus Roemer measures the Velocity of Light, 1676.**

—While Newton was dispersing light in prisms, and finding out its nature, Olaus Roemer, a famous Danish astronomer (born 1644, died 1710), was engaged in something almost as wonderful. He was measuring the rate at which light travels across the sky! It seems at first as if this would be impossible, but we now know three different ways of accomplishing it; Roemer's was the first attempt ever made, and his measurement was very near indeed to the truth.

You will remember that Jupiter has four moons, which move round it as our moon moves round our earth. Three of these moons are so near to Jupiter, and move round it in such a manner, that they pass through its shadow and are eclipsed every time they go round. Now it became very useful, for certain astronomical reasons, to know exactly when these eclipses happened, and the time of their occurrence was therefore calculated very carefully ever since Galileo first discovered them. There was no difficulty in doing this, and yet, strange to say, the eclipses rarely happened *exactly at the right moment*. Sometimes they were too early, some-



times too late ; and they varied, according to some regular rule, as much as 16 minutes 36 seconds on each side of the exact moment when they ought to have happened.

At last it occurred to Roemer, and to an Italian astronomer named Cassini, that, as Jupiter is farther away from the earth at one time than another, the eclipses might be seen some minutes later whenever the rays of light from the moons had to cross a greater distance to reach the earth. Cassini seems to have put the thought aside and not to have worked it out ; but Roemer seized upon it, and by careful calculations proved that it was the true answer to the difficulty. If the earth was at E (Fig. 34) for example, when

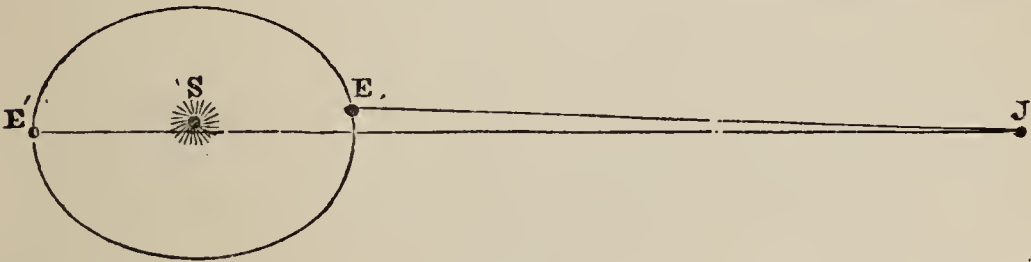

FIG. 34.

Different Distances at which Jupiter's Light reaches the Earth.

J, Jupiter. E E', The Earth.

Jupiter was at J, the light would not have nearly so far to travel as if the earth was at E' ; and in this last position the 16 minutes 36 seconds would be taken up by the light crossing the earth's orbit from E to E'. This distance was known to be about 190,000,000 miles, so that light travels at the rate of 190,000,000 miles in 996 seconds, or about 190,000 miles in a second. This is *nine million times* as fast as the quickest express train.

**Huyghens and Newton—Theories of Light.**—The time had now come when so much was known about the way in which light behaves, that philosophers began to ask themselves, 'What is Light?'—a question by no means so easily answered as you may think ; for though it is by means of

light that we see everything, yet light in itself is invisible. You will exclaim at once that you can see a sunbeam shining through a crack in a window-shutter. But what you see is not light itself, it is the particles of dust or smoke which reflect the light so that they shine. There is one very simple way of proving to yourself that rays of light are not visible lines. When the moon is shining you know that it is reflecting the light of the sun, therefore there must be light crossing the sky and falling upon the surface of the moon. But now look up some other night when the moon is not there. All is darkness ; yet the light must be there just the same, and would have caused the moon to shine if it had been there also, but as there is nothing to reflect it to your eye it is invisible.

What, then, is this light, invisible in itself, yet without which we can see nothing? Newton thought that it was composed of minute invisible particles of matter which darted out in straight lines from *luminous* or light-giving bodies, and falling upon our eyes caused the sensation which we call light. This is called the *Corpuscular*, or sometimes the *Emission, Theory of Light*. It was very ingenious, and accounted for a great many of the facts, but there were many others which it did not explain ; and I will not attempt to describe it to you, because another theory, called the *Undulatory (or wave) Theory of Light*, has now been found to be much more complete and satisfactory. This last theory was proposed by a Dutch mathematician and astronomer named Christian Huyghens, the son of Constantine Huyghens, Counsellor to the Prince of Orange.

Christian Huyghens was born at the Hague, in Holland, in the year 1629 ; when he was only thirteen years old he was already passionately fond of mathematics, and examined every piece of machinery that fell in his way. He

received a very good education, and wrote some able treatises upon geometry when he was only two-and-twenty. From this time he advanced very rapidly, both writing valuable papers and making grand discoveries. In 1658 he invented a peculiar kind of pendulum called the cycloidal pendulum, which would keep accurate time when swinging over wide spaces; and he was also the first to apply pendulums to clocks. In 1659 he made a telescope ten feet long, with which he discovered one of Saturn's satellites, and described accurately Saturn's ring, which Galileo had mistaken for two stars. In 1660 he came to England and solved some questions which the Royal Society had proposed about the laws of motion. Then he was invited to settle in France, and it was there, in 1678, that he read before the 'Académie des Sciences' the theory of light which we must now try to understand.

**Undulatory Theory of Light, 1678.**—We have seen that it had been known ever since the time of the Greeks, that *sound* is caused by a trembling or vibration of the air, so that when you strike the wire of a harp, the trembling of the string shakes the air, and the quivering motion travels along until some wave strikes the drum of your ear and produces the sensation we call sound.

Now Huyghens said, 'We can only explain light by supposing it to be a *vibration* like sound.' But here at the very outset came a difficulty. We know that light is not a vibration of the *air*, for if you draw the air completely out of a glass vessel, light will still pass across it; and besides, we get light from the sun and the distant stars, so that it has to come across a great airless space before it reaches the atmosphere of our earth. And yet, if light is a vibration, it is clear there must be something between the sun and us to vibrate. To meet this difficulty Huyghens supposed the

*whole of space between our earth and the most distant stars to be filled with an elastic invisible substance which he called 'ether.'* He assumed this substance to be so fine and subtle that it passes between the atoms, even of solid objects, and that the sun and all luminous bodies cause it to vibrate so that its *undulations* or waves strike upon our eyes and give rise to the sensation we call light.

Thus, according to this theory, when you look at the sun, the invisible 'ether' filling the whole space between you and it, is moving up and down in rapid vibrations, just as if the sun held one end of a cloth and you the other, and the sun was shaking the cloth so that the waves travelled along it to your eye; and every wave that hit you would cause the sensation called light.

This theory explains very well how light-waves may be in the sky and yet we may not see them; for if a stick is moving rapidly to and fro in the air, and you go within reach of it you feel *pain*, but if you keep out of reach no pain is produced. In the same way, when the vibration of this invisible ether strikes your eye you feel *light*, but though the waves may be travelling rapidly across the sky, so long as they do not fall upon your eye, no light will be produced to you.

But suppose you were not looking at the sun, but at the ground, why should you still see? Because the waves from the sun which strike the ground cannot travel on so easily through the solid earth as through the pure ether, so a great number of them bound off and vibrate back along the ether again, from the ground to your eye; and as they vibrate differently according as the ground is rough or smooth, hard or soft, wet or dry, they make a different impression upon your eye, and cause you to see a picture of the ground as it is.

Clear white glass and other perfectly transparent bodies

allow nearly all the waves of light to pass through them and send hardly any back to your eye ; and people have in consequence been known to walk right up against glass doors without seeing them. Bright polished surfaces, on the contrary, like steel and mercury, turn nearly all the waves back again, and this is why we see our own faces reflected so clearly in a looking-glass, where it is the mercury at the back which is the real mirror.

If we had room we might follow out these light-vibrations in a very interesting manner. For instance, why does a leaf look green and a soldier's coat red? Because, as in sound the kind of note you hear depends upon the quickness of the vibrations of the air, so in light it depends upon the quickness of the vibrations of the ether what colour you see. The vibrations which produce violet, indigo, blue, green, yellow, orange, and red, have travelled all together as white light through the ether, but they are differently treated by the leaf. All except the green waves are quenched, or *absorbed* as it is called, by the material of the leaf, and only the green waves bound back upon your eye. In other words, the vibrations of the ether coming from the leaf move exactly fast enough to produce upon your eye the sensation you call *green*, just as the vibration of the air caused by a particular string of a harp produces on your ear the sensation of the note you call the middle C.

**Refraction of Light explained by Huyghens.**—But we must now go back to Huyghens, and point out how beautifully he explained by his *undulatory theory* the refraction or bending-back of rays of which we have already spoken so much. When a wave of light is travelling onwards, he said, if it passes vertically into glass or any denser substance, the wave will move more slowly, but it will still go straight on, because both ends of the wave will be equally checked.

But if the wave goes into the glass *obliquely* (see p. 47), or into a glass with a rounded edge, one end of it will reach the glass first before the other, and will move slowly, while the other end goes on unchecked, and so the wave will *swing round* and will have its direction altered. In the same way, when it passes out again from the glass, one end will pass out first, and will move more easily in the air than the end that is still in the glass, and so it will swing round again and make another bend.

This is somewhat difficult to understand at first sight, and it will be best explained by a very ingenious experiment proposed by Mr. E. B. Tylor.<sup>1</sup> Take two small wheels about

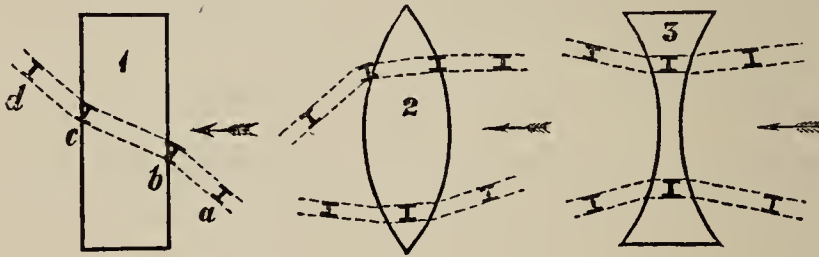

FIG. 35.

Figures illustrating the passage of the waves of light through different-shaped lenses (Tylor).

2 inches round, and mount them loosely upon a stout iron axle measuring about half-an-inch round. This will make a runner like two wheels of a cart, and if you let it roll down a smooth board it will represent very fairly the crests or tops of the waves of light in the ether. Let your board be about  $2\frac{1}{2}$  feet long, and at one end of it glue on pieces of thick-piled velvet of the shape of lenses (see 1, 2, 3, Fig. 35). Let your runner first go straight down the board upon the oblong velvet, it will then run through the velvet without changing its course, as a vertical ray does through a lens. Then start it obliquely, as at *a*, across the board, so that it

<sup>1</sup> 'Nature,' vol. ix. 1874, p. 158.

will reach the velvet in the position *b*. Here the left wheel of the runner will touch the velvet first, and will be checked by the rough pile, while the right wheel moves on quickly as before, and thus the runner will swing round or be refracted into the direction *b c*. Then, as it passes out again, the left wheel will come out of the velvet first and will move more quickly on the smooth board, while the right is still checked by the velvet; therefore the runner will again be shifted round or *refracted* as it passes out into the direction *c d*. In figure 2, on the other hand, even if the runner passes in vertically, yet the rounded surface of the lens causes the left wheel to enter first, and as, in consequence of the rounding of the second surface this same wheel comes out last, the ray is refracted inwards along its whole course. You can easily follow the course of the runner through the other lens for yourself, always noticing that the arrow marks which way the ray of light is coming; and when you have done this you will have a beautiful imitation of the way in which the waves of light are *refracted* in passing from one medium to another.

**Double Refraction.**—There is another remarkable fact about light which Huyghens explained; namely, the *double refraction* of light through a crystal called Iceland spar. A physician of Copenhagen named Erasmus Bartholinus had received from Iceland a crystal in the form of a rhomboid (see Fig. 36), which, when broken, fell into pieces of the same shape. Bartholinus called this crystal ‘Iceland spar,’ and while making experiments with it he observed that an inkspot or any small object seen through it appeared to be doubled. He was not able to explain this curious fact, but he published an account of it in 1669, and Huyghens accounted for it quite correctly by suggesting that the crystal was more



FIG. 36.

A spot of ink seen through a crystal of Iceland spar.

elastic in one direction than in the other, so that a wave of light passing into it was divided into two waves moving at different rates through the crystals. This would cause them to be bent differently—one according to Snell's ordinary law of refraction (see p. 105), and the other in an extraordinary way. Thus these two separate rays entering the eye would cause there the impression of two objects.

This curious effect is very interesting to study, and it led Huyghens to make a number of remarkable experiments. He found that the two rays when they passed out at the other side of the crystal remained quite separate the one from the other, and if they were afterwards sent through another crystal in the same direction that they had gone through the first, they went on each their own way. But now came a very extraordinary fact: if the second crystal was turned round a little so that the rays passed in rather a different direction through it, each ray was again split up into two, so that there were now *four* rays, sometimes all equally bright, sometimes of unequal brightness, but the light of all four was never greater than the light of the *one* ray, out of which they had all come. These four rays continued apart while he turned the second crystal more and more round; till, when he had turned it 90°, or a quarter of a circle, the rays became *two* again, with this remarkable peculiarity, that they had changed characters! The ray which before had been refracted in the ordinary way now took the extraordinary direction, while the other chose the ordinary one.

This curious effect observed by Huyghens is now known as the '*polarisation of light*' by crystals. There is a beautiful explanation of it, but we must wait for that till we consider the science of the nineteenth century, for it is now much better understood. Huyghens' '*Theory of Light*' was pub-



---

lished in 1690, under the title 'Traité de la Lumière.' He remained in Paris for some years; but left and returned to Holland when the persecution of the Protestants began after the revocation of the Edict of Nantes. He died in 1695.

---

*Chief Works consulted.*—Herschel's 'Familiar Lectures'—art. 'Light;' Tylor, 'On Refraction'—'Nature,' vol. ix.; 'Edin. Phil. Journal,' vols. ii. and iii.—'On Double Refraction;' Ganot's 'Physics;' Encyclopædias—'Britannica,' 'Metropolitana,' and Brewster's.

## CHAPTER XXII.

## SUMMARY OF THE SCIENCE OF THE SEVENTEENTH CENTURY.

WE have now arrived at the close of the seventeenth century. and it only remains for us, before going further, to try and picture to ourselves the great steps in advance which had been made between the years 1600 and 1700. We saw at p. 80 that the work of the sixteenth century consisted chiefly in making men aware of their own ignorance, and teaching them to inquire into the facts of nature, instead of merely repeating what they had heard from others. In the seventeenth century we find them following out this rule of patient research, and being rewarded by arriving at grand and true laws.

**Astronomy.**—To begin with Astronomy. Here Galileo led the way with his telescope. The structure of the moon, with its mountains and valleys; the existence of Jupiter's four moons revolving round it and giving it light by night; the myriads of stars of the Milky Way; the spots of the sun coming into view at regular intervals, and thus proving that the sun turns on its axis; all these discoveries forced upon men's minds the truth that our little world is not the centre of everything, but a mere speck among the millions of heavenly bodies. But while they humbled man's false pride in his own importance, they taught him, on the other hand, the true greatness which God has put in his power by giving

him the intellect to discover and understand these wonderful truths if he will only seek them in an earnest and teachable spirit.

Then came Kepler with a still grander lesson, for he showed that the movements of the planets are governed by regular and fixed laws, which can be traced out so accurately that an astronomer is able to foretell with confidence what will happen many years after he himself has passed away. Thus we see Gassendi and Horrocks, by the use of Kepler's labours, calculating within a few minutes the time of a planet's passage across the face of the sun and watching the exact fulfilment of the prediction. Nor is this all : so exact and true are these movements, and so completely is man able to read them rightly, that by this simple passage of a small black spot across the sun Halley showed that we may actually number the millions of miles between ourselves and the great light around which we move. We might almost think that we had now travelled as far as man's mind could go, but something far greater remained behind. Newton sitting under his apple-tree and pondering on the wonderful mechanism of the heavens, found the one great law which accounts for the movements of all the bodies in the universe—a law which explains equally why a pin falls to the ground and why a comet which has been lost to sight for more than seventy years will return to a certain fixed spot at a day and an hour which can be accurately foretold. Kepler had pointed out fixed and definite laws by which the universe is governed ; Newton demonstrated that one law explains them all. He showed us how one single thought, as it were, of the Divine mind suffices to govern the most complicated as well as the simplest movements of our system.

All this advance from Galileo to Newton was the work

of the seventeenth century. It began, you see, with certain simple facts ; by Galileo seeing that bodies existed in the heavens which were not known to be there before ; it ended in the beautiful law of which we have just spoken. But I want you particularly to notice that this end would never have been reached by men who were content to sit down idly and *talk* of the greatness of God. It was the result of real *work* by men who tried first to learn the facts, and from these to prove reverently the way in which it pleases God to bring them about ; and in this labour of love, being brought face to face with the infinite grandeur of nature, they learnt that true humility which led Newton, the greatest of them all, to feel that he was but as a little child gathering pebbles on the shore of the great ocean of truth.

**Physics.**—If we now turn to Physics, we shall find that the way to knowledge lay still along the same road of patient inquiry. Torricelli's barometer and Guericke's hemispheres of Magdeburg both proved by direct experiment that the atmosphere round our earth is pressing in all directions equally with great force ; and this again brings us round to the force of gravity, which is the cause of this pressure ; while Boyle's experiment showed that air is elastic, being compressed in exact proportion as the weight upon it is increased, and expanding again directly it is diminished. Newton showed that this elasticity of air gives rise to the waves of condensation and rarefaction, which convey an original impulse across wide spaces and produce the effect of sound upon our ears.

Again, in the subject of Light, we begin with hard dry facts, which doubtless you may have thought it wearisome to master, but we end with a theory so wonderful and beautiful that it seems more like a fairy-tale than sober science. The first step here was the invention of the telescope, which,

while it opened the road on the one hand to astronomical discoveries, also led to the grinding of lenses, and to a more careful study of the laws of light. This it was which caused Snellius to make experiments on the bending of rays with a view to improving telescopes, and so to discover the law of refraction, afterwards more fully stated by Descartes. Then we find this last philosopher trying to explain the rainbow, and studying the colours falling through a prism, and so the subject passed on into the hands of Newton.

Here, by experiment again, the threads of light were disentangled in the prism, and Newton drew out its many-coloured rays, tracing them one by one on their road, till he had shown how they can be explained by dispersion, and that to this law, which seemed so uninteresting at first, we owe all the lovely colours which surround us. And now Huyghens takes up the story and leads us fairly into the invisible world. This light, which Roemer had proved to be travelling across space with marvellous speed, Huyghens shows to be no actual substance at all, but most probably a trembling of an invisible and intangible ether—a succession of infinitely tiny waves chasing each other across millions of miles, and striking at last on the minute opening of our eye, bringing to us the wonderful effects of light. As Newton traced colours, so Huyghens traces the invisible waves through many substances, showing us their path and why they take it; and landing us at last in the bewildering effects of polarisation, leaves us there to wait for more knowledge in a future century.

**Biology.**—And now we come to Biology, or the study of all those sciences which relate to life. Here you must remember that our account of the discoveries made must be more than usually imperfect, because the subject is more than usually difficult. Yet we can form some idea of the new

---

light thrown upon the nature of the living body, by Harvey's theory of the circulation of the blood and the discoveries which followed concerning the way in which nourishment is carried to it. We can see how Mayow's experiments, proving that part of the air is burnt within us, supplying heat to our bodies, would have been a grand step in advance if he had lived to make them more known, and how, indeed, they did influence those who came after, though his name was for a time forgotten. More clearly still we can understand how Malpighi's and Grew's investigations with the microscope, bringing to light hidden parts and vessels of the human frame, gave rise to a totally new branch of science, and enabled men to study the organisation of their own bodies with an accuracy quite impossible before ; while the same method applied to Botany gave the first real insight into the structure of plants, tracing out their delicate organs, and even the tiny cells of which their flesh is composed. And lastly, in the field of Natural History, we find that Ray and Willughby performed the immense task of classifying the whole animal and vegetable kingdoms, and laid the foundation of the grand generalisations of Linnæus in the next century.

SCIENCE OF THE  
EIGHTEENTH CENTURY.

*Chief Men of Science in the Eighteenth Century.*

	A.D.
Boerhaave . . . . .	1668-1738
Hales . . . . .	1677-1761
Haller . . . . .	1708-1777
Hunter . . . . .	1728-1793
Bonnet . . . . .	1720-1793
Spallanzani . . . . .	1729-1799
Buffon . . . . .	1707-1788
Linnæus . . . . .	1707-1778
Jussieu . . . . .	1699-1777
Lazzaro Moro . . . . .	1687 —
Werner . . . . .	1750-1817
Hutton . . . . .	1726-1797
William Smith . . . . .	1769-1839
Black . . . . .	1728-1792
Bergmann . . . . .	1735-1784
Cavendish . . . . .	1731-1810
Priestley . . . . .	1733-1804
Scheele . . . . .	1742-1786
Rutherford . . . . .	1749-1819
Lavoisier . . . . .	1743-1794
Sauveur . . . . .	1653 1716
Bernoulli . . . . .	1700-1782
Euler . . . . .	1707-1783
Chladeic . . . . .	1756-1827
Watt . . . . .	1736-1819
Franklin . . . . .	1706-1790
Galvani . . . . .	1737-1798
Volta . . . . .	1745-1827
Maskelyne . . . . .	1732-1811
Lagrange . . . . .	1736-1813
Laplace . . . . .	1749-1827
Herschel . . . . .	1738-1822



## CHAPTER XXIII.

## SCIENCE OF THE EIGHTEENTH CENTURY.

Great spread of Science in the Eighteenth Century—Foundation of Leyden University in 1574—Boerhaave, 1701—Organic Chemistry—Dr. Hales' Experiments on Plants—Great Popularity of Boerhaave's Chemical Lectures.

WE have now arrived at the beginning of the eighteenth century, only 179 years before our own day, when the different sciences which we have been tracing in their rise, like little rills on the mountain sides, were beginning to swell out into mighty streams, widening and spreading so rapidly that it is in vain we strain our eyes to try and watch them all. The time had now come when any man who wished to be a discoverer was obliged to devote his whole life to one branch of science, following it out in all its intricate windings. And so we find that about this time each science begins to have a complete history of its own, with its own eminent men, and its peculiar language growing more and more technical, so as scarcely to be understood by ordinary readers.

For this reason most general histories of Science stop at this point and refer their readers to special works on the different sciences. I do not, however, propose to do this; for though, owing to the great strides which were being made, it will be impossible to give more than a few glimpses of the work that was being done, still I think that if we

struggle on through the increasing mass of knowledge and gather up a fragment here and there, a general idea of the progress of science may be gained such as will enable young readers to turn to more advanced scientific books with much greater interest, even though they may learn very little of any one science.

Astronomy, Physics, and to a certain extent Chemistry, had made such a start at the end of the seventeenth century that it was a great many years before those men who came after Newton, Halley, Huyghens, and Stahl, had mastered the new discoveries sufficiently to progress any farther. Therefore we find that it was not in these sciences that most advance was made in the beginning of the eighteenth century, but in those which relate to living beings, and which are all included under the head of Biology, or the science of life. Medicine, Anatomy, and Physiology were the branches which grew most rapidly about this time; and the five great men whose names stand out most conspicuously are Boerhaave, Haller, John Hunter, Bonnet, and Spallanzani: Boerhaave as the founder of the study of *organic chemistry*, Haller and Hunter as the fathers of *comparative anatomy*, and Bonnet and Spallanzani as the discoverers of some very remarkable facts in *physiology*. We will take these subjects in regular order, and try to understand something of the work which was done in them.

**Medical School of Leyden.—Foundation of Organic Chemistry by Boerhaave, 1701.**—On the coast of Holland, just where the Rhine empties itself by a number of small channels into the German ocean, stands the city of Leyden, which became famous in the year 1574, on account of a siege of four months which the starving inhabitants endured with the utmost heroism, when the Protestant Netherlanders were struggling for life and liberty against Philip II. of Spain.

The Dutchmen were successful at last, and drove out the Spanish army, by cutting away the dykes and letting in the sea to swallow up their beautiful pastures, their neat villages, and their fruitful orchards; and as a reward for their devotion to the cause, William of Orange founded the University of Leyden, which afterwards became very celebrated.

Hermann Boerhaave, of whose work we are now going to speak, was a Professor of Medicine in this University about a hundred years after its commencement. The son of a Dutch clergyman, he was born in 1668 at Vorhout, one of those same small Dutch villages near Leyden which had been for days under the sea in 1574. His father intended him for the church; but the young student, having been accused of holding false opinions, was only too glad of this excuse to give up theology and study medicine, in which he delighted. He was so successful that in 1701 he was made Lecturer of Medicine in the University, and a few years later the Professorships of Chemistry and Botany were also given to him. From that time the Medical School of Leyden became famous all over the world. Students flocked to it from all quarters, and most of the best medical men of Europe were pupils of Boerhaave. This was due chiefly, of course, to his wonderful medical knowledge and his skill as a lecturer; but his popularity was greatly increased by his enthusiasm, kindly temper, and the great interest which he took in the success of his pupils. He was always ready to help others and to give them credit for the work they had done, and it is said that even his enemies could not resist his constant and uniform kindness and good-temper. He loved his science too well to hinder its progress by angry disputes; and by imparting this spirit to his pupils he did almost as much for the

spread of medical science as by the facts which he taught them.

But besides his influence upon medicine in general there was one particular study which Boerhaave may be said to have founded; namely that of *organic chemistry*, or the chemical analysis of substances occurring in plants and animals. You will remember that the false science of alchemy had always been much mixed up with chemistry, and the alchemists had some strange mystical notions about 'vital fluids,' which they supposed to exist in animals and plants, and to cause their life and growth. Little by little, however, more correct ideas had grown up in the sixteenth and seventeenth centuries about the nature of life. Vesalius, Harvey, Malpighi, Grew, and many others, had gradually described more and more accurately the working of the different organs of a living being, and now Boerhaave went farther, and tried to discover by means of chemistry of what materials these organs themselves are composed.

In the same way that Geber had decomposed or divided up *inorganic* substances, such as metals and earths, by distillation and sublimation (see p. 43), so Boerhaave proposed to decompose the *organic* structures of plants and animals, and to discover the materials contained in them. To accomplish this he took a plant, such as rosemary, and putting fresh moist leaves of it into a furnace, heated them gently and drove out all the moisture, which he collected in a separate vessel. When this moisture had cooled down into a liquid he examined it and found that it was made up of water, and of different kinds of oils and essences, according to the plant he had taken. For instance, from rosemary he got an essence with the peculiar scent of rosemary; from the bark of the cinnamon tree, *Laurus Camphorum*, or *Cinnamomum camphorum*, he got essence of

cinnamon ; from its roots, camphor ; and from its leaves an oil with the taste of cloves. Then after he had extracted all the juice from the plant, he burnt the dry remains, to see what would be contained in its ashes after the fire had driven off part of the solid matter as gas, and he found in them a kind of salt, which was also different in different plants. But if he poured hot water on the plant before burning it, he found no salt in the ashes, for it had been dissolved and carried off in the water.

Having now found of what materials the plant was composed, the next step was to discover where they came from ; so he took several specimens of earth in which plants can grow and examined them also ; and he found that he could extract from them many of the substances, such as salt, alum, borax, and sulphur, which he had also discovered in the ashes of the plants. It was clear, then, that the plant took these salts out of the earth ; and by a number of experiments he went on to prove that they are dissolved by the rain-water which sinks into the earth, and are then sucked up by the plants through their roots and carried up to the leaves, where they are exposed to the air and sunshine, and altered so as to become food for the plant. The other parts which did not come from the soil he concluded must be taken in from the air. These were splendid facts, and curiously enough a celebrated English chemist, Dr. Hales (born 1677, died 1761), made some similar experiments almost at the same time, which confirmed those of Boerhaave. Hales even went so far as to measure the quantity of water taken in at the roots and given out at the leaves of plants, and he discovered the way in which plants breathe through the little *stomata*, or mouths, discovered by Grew (see p. 138).

From the juices of plants Boerhaave next went on to

those of animals, and he decomposed in a most beautiful and simple manner milk, blood, bile, and those fluids called chyle and lymph which convey nourishment to the blood. These he compared with the sap, gums, resins, and oils of plants, and showed that animal bodies are made up of altered vegetable matter, just as plants are in their turn composed of matter taken from the soil and the air; and he suggested that by careful experiments it would at last be possible to discover exactly the materials of which all living beings were made.

Boerhaave's analyses of organic substances were very rough and imperfect compared to those which are made now; for you must remember that the four gases, oxygen, hydrogen, nitrogen, and carbonic acid, which we now know are the chief constituents of plants, were not yet discovered. Yet even these rough attempts were so interesting that students crowded round the doors of his lecture-room for hours before the lecture began, to secure admission; and there can be no doubt that his 'Elements of Chemistry,' published in 1732, contained the first steps in the study of the chemistry of living things. Boerhaave was also a celebrated botanist. He died in 1738, and deserves always to be remembered as one of the greatest teachers of the eighteenth century.

---

*Chief Works consulted.*—Brewster's 'Encyclopædia'—'Boerhaave'; Miller's 'Organic Chemistry,' 1869; Cuvier, 'Hist. des Sciences Naturelles'; Sprengel, 'Hist. de la Médecine,' 1815; Burton's 'Life and Writings of Boerhaave,' 1746; Boerhaave, 'Elements of Chemistry,' Englished by Dallowe, 1735; Hales' 'Essays concerning Vegetable Staticks,' 1759.

## CHAPTER XXIV.

## SCIENCE OF THE EIGHTEENTH CENTURY (CONTINUED).

Haller—Foundation of Göttingen University—Rise of Comparative Anatomy—John Hunter—His Museum—Bonnet—Spallanzani.

**Haller, 1708-1777.**—Among the pupils of Boerhaave there was one man who became, in some respects, even more famous than his master. This was Albert von Haller, son of the Chancellor of Baden, who was born at Berne in 1708, and died in 1777. Haller seems to have been a most extraordinary child; at nine years of age it is said that he knew Latin and Greek, and had written a Hebrew and Greek dictionary, a Chaldean grammar, and an historical dictionary! We are not told how good these books were; but how very few boys of nine years old would have been able to write them at all! At seventeen Haller went to Leyden to study under Boerhaave, and under Albinus, a famous anatomist; and at nineteen he was already a doctor of medicine. Having been driven out of Paris because the people were horrified at his dissecting dead bodies, he went to Berne, where he became professor of anatomy; and in 1736, when George II. of England, who was also Elector of Hanover, founded the University of Göttingen, he went there as professor of anatomy, surgery, and botany, and soon made that University as famous as Boerhaave had made that of Leyden.

One of his first reforms was to turn the work of his pupils

to good account. When medical students are going to pass their last examination they are required to write an essay, or *thesis*, as it is called, before they can receive their degree of doctor. Haller used always at these times to propose to each one of his students some difficult point in anatomy or physiology, in which he thought new discoveries might be made, and he then drew out a plan for them and showed them how to begin. By this means their essays were often full of new and useful information, and it was a great deal owing to the help of his pupils that Haller was able to publish 180 volumes on science, all more or less valuable.

There was also a very good anatomical theatre at Göttingen, and from dissections made there Haller produced a set of most beautiful anatomical drawings, which he published between 1743 and 1753. You will remember that Vesalius published many fine engravings of parts of the human body (see p. 65), and since his time many others had been made, especially by Haller's master, Albinus. But Vesalius' drawings were coarse, because he had no microscope to help him, and Albinus had only drawn separate parts, such as a muscle, a nerve, or a vein. Haller's plates were the first which showed the different nerves and vessels attached in their right position, and to each plate he added a complete history of the *function*, or use of the parts drawn. He made these drawings so accurate, and spent so much time upon each minute structure, that in seventeen years, with all the help he had, he was not able to complete the description of the whole human body.

**Haller discovers the Power of the Muscles to Contract.**—It was while he was at work at these dissections, that he made one great discovery, which you must try to understand. If you clasp your right hand round your left arm, just above the elbow, and then bend your left arm, you



will feel the part under your hand swell up and grow hard. The reason of this is that the muscle of your arm, called the biceps, has contracted, or grown shorter and thicker, in the process of bending your arm. If you open your arm again, the swelling will go down, because the muscle is stretched out. Now before Haller's time it was thought that the muscles could not contract of themselves, but were drawn up by the nerves. Haller discovered that this is not so, but that a muscle, if irritated, will draw itself together, even when it is quite separated from the nerves, and this has since been proved to be true by a great number of experiments. So that though it is true that our nerves are the cause of our moving, because they excite the muscles and so make them contract, yet the real power of contraction is in the muscle itself.

**Comparative Anatomy, or the Comparison of Different Structures in Men and Animals.—John Hunter.**  
—Another point in which Haller did good service to science was in comparing the same parts of the body of men and animals, and showing how far they are alike. This study, which is called the study of *comparative anatomy*, has now become very important, for by examining any organ, such as the heart, for example, from the lower animals in which it is very simple, up to man in whom it is complicated, we can trace its gradual improvement, and understand it much more perfectly. Aristotle and Vesalius had both of them compared some of the parts of different animals, and so had other and later zoologists; but Haller was the first to make it a regular study, and John Hunter, who lived about the same time, devoted his whole life to it, and raised it to the rank of a separate science.

John Hunter, who was born in the County of Lanark, in 1728, was the brother of a very eminent London phy-

sician, Dr. William Hunter, who was also a great anatomist. John, being delicate, had been allowed to grow up with very little education, and at twenty years of age he came up to London, a mere ignorant lad, to try and help his brother in his anatomical dissections. Here he soon showed that he had plenty of ability, for he learnt dissecting so rapidly that at the end of a year he was able to teach his brother's pupils, and before long he became one of the leading surgeons at St. George's Hospital, and had a large private practice.

But though he made a great deal of money by his profession, he spent it all upon his favourite study of anatomy, to which he devoted every spare moment. His great wish was to compare thoroughly the different parts of men and animals, so as to show how the life of each one of them is carried on. For this purpose he dissected and preserved in different ways all the bodies of animals upon which he could lay his hands. He bought up all the wild beasts that died in the Tower, where they were then kept, and any which he could procure from travelling menageries, and he even kept foreign animals himself in a piece of ground at Earl's Court, Brompton, that he might watch their habits and dissect their dead bodies.

As years went on and his specimens increased, he built a large museum in Leicester Square, and arranged his collection so as to show which parts in different animals serve for the same use. For example, to illustrate the way in which animals digest their food, he placed first the hydras, polyps, and sea-anemones, which are all stomach, being in themselves nothing but a simple bag surrounded by little feelers, and having a fluid inside which dissolves the food. Then he arranged in order many forms up to the leech, which is a bag with two openings, and has a head and nerves and other parts, besides a stomach. Then came the insects,

some of which, as the bees, have a separate receptacle for honey, of which they disgorge a part and then pass on the rest into the real stomach. Then came the snails, in which the stomach is a separate part with a second opening to pass out the food it cannot take up. Then the fishes, some of whom have stomachs strong enough to crush the shells and indigestible parts of their food, while others have the mouth lined with teeth for this purpose; then came the stomachs of reptiles; and afterwards those of birds, with the curious crop where the food lies first, and the gizzard, in which it is rubbed against the little stones which the bird swallows. Then finally came the stomachs of the higher animals, with many curious and interesting peculiarities; as, for example, the divided stomach of those animals, such as the cow, which chew the cud, and of the camel, in which one division serves as a water-bag. And side by side with these organs of digestion he placed the teeth of each animal, showing how these were each exactly fitted to prepare the food for the particular kind of stomach of the animal to which they belonged.

In this way Hunter tried to arrange the history of all the different organs of the body, tracing out each as perfectly as he could, and showing how it suited the wants of the various animals. His museum cost him an immense amount of labour, and more than £70,000 in money; when he died, in 1793, it was bought by the English Government for £15,000 and placed in the London College of Surgeons, and for the last eighty years many a London student of physiology has had occasion to be thankful to the rough and uneducated John Hunter for the laborious and careful work he did, and the magnificent collection he left behind him.

**Experiments upon Animals by Bonnet and Spallanzani.**—While Haller and Hunter by their dissections were

adding greatly to our knowledge of the *structure* of animals, two famous naturalists in Switzerland and Italy were bringing to light some extremely curious and interesting facts about their *growth*.

The first of these, named Charles Bonnet, was born at Geneva in 1720, and died in 1793. He had a great love of natural history, and when he was twenty years of age he wrote a paper upon *aphides*, or plant-lice, which was so remarkable that the French Academy of Sciences at once elected him one of their corresponding members. He also made some very interesting experiments upon plants, showing that they have the power of seeking out for themselves what is necessary for their growth. We all know that plants grow towards the light, and if kept in a dark room will seek out even a crack through which the light comes. But Bonnet proved that they will do much more than this, for he found that if he twisted the branch of a tree so as to turn the leaves bottom upwards, in a little time each leaf turned right round on its stalk so as to get back into its natural position ; while on the other hand, if he hung a wet sponge over a leaf, the leaf would turn its under side upwards, so as to bring the little mouths, or stomata, close to the sponge, and enable them to drink in the water. In this way a plant will always find out the best way of growing so as to get as much sun and food as it can. Many curious facts of this kind were published in Bonnet's work on the 'Use of the Leaves of Plants,' but what I wish now particularly to relate to you are his experiments upon animals and the regrowth of limbs which had been cut off.

It had long been known that very simple organisms, such as polyps, may be cut in pieces, and each part will live and become a perfect creature ; but no one thought it possible that any of the more complicated living beings could be

treated in this way. Bonnet, however, and the famous Italian naturalist Spallanzani (1729-1799) proved by a great number of experiments that tails, legs, and even heads will grow again in some animals, after they have been cut off. The garden-worm, for example, is an animal with many organs : it has numerous bristles, which serve as feet, it has arteries and veins, nerves, and organs of digestion, and a mouth ; yet Bonnet found that a worm if cut in pieces would grow a new head or a new tail, and, what was still more curious, in some rare cases it grew the head on the end where the tail had been before !

Spallanzani went even farther than this, for he experimented on snails. Now the common garden snail has a head with four horns, moved by very complicated muscles, and two of these horns have eyes at the end of them ; moreover it has a mouth, with teeth and a tongue. Spallanzani cut off first the horns with eyes, and afterwards the mouth and tongue, and found that the snail had power to re-grow them all. He then tried upon aquatic salamanders, which resemble our newts, or efts. These creatures have red blood like ourselves, they have a heart, lungs, bones, and muscles, and their legs possess muscles and nerves like those of a man ; yet Spallanzani cut off the tail and legs of one salamander six times in succession, and in another case, Bonnet cut them off eight times, and they grew again. Bonnet even took out the right eye of a newt, or eft, and in eight months another eye had grown in its place. These experiments were very startling, for they showed that the life of the lower animals does not so much depend on a particular part of the body, as it does in ourselves and in the higher animals. If you cut off the head of a man or an ox, they die, or if you cut off a leg, it never grows again ; but these experiments proved that the worm and the snail live and grow new

heads and limbs, and that the more simple an animal is, the more power it has to live and grow after it is cut in pieces.

These discoveries led Bonnet to make a suggestion which should be remembered, because it has become of great importance in the present study of natural history. He asked whether it was not likely that there was a gradual development or complication of the parts of the body as you ascend from the lowest plant up to the highest animal, so that the body of a worm, for example, could do all the work necessary to keep it alive and make it grow, without the help of its head, and a lizard could in the same way make a new leg without much difficulty. But as the machinery grew more and more complicated this would not be so easy, till at last it would become impossible in the higher animals, just as in a complicated machine one broken wheel will upset the whole working. Bonnet wrote a book called 'The Contemplation of Nature,' in which he dwelt upon this subject, and tried to trace out how animal forms had become gradually higher and higher, till they had arrived at man. We shall see by and by how this idea occurred also to the naturalist Lamarck, and how it has become the foundation of a grand theory of life in the present century. Meanwhile you must bear in mind that Bonnet and Spallanzani added enormously to our knowledge of the lower animals and their powers of life, and together with Boerhaave, Haller, and Hunter did a great deal to advance the sciences of anatomy and physiology in the beginning of the eighteenth century.

---

*Chief Works consulted.*—'Life of Haller'—'Naturalists' Library; Brewster's 'Encyclopædia,' arts. 'Physiology' and 'Haller; Lawrence's 'Lectures on Comparative Anatomy,' 1816 and 1848; Lawrence's Translation of Blumenbach's 'System of Comparative Anatomy,' 1807; 'Life of John Hunter'—'Naturalists' Library,' vol. x. ; Cuvier, 'Hist. des Sciences Naturelles; Carpenter's 'Comparative Physiology; Tom Taylor's 'Leicester Square,' Appendix by Professor Owen.

## CHAPTER XXV.

Buffon and Linnæus compared—Buffon on Natural History—Daubenton—Linnæus—Linnæan or Artificial System—Natural System—Character and Death of Linnæus.

**Advance of Natural History—Buffon and Linnæus.**—In the year 1707 two men were born, the one in France and the other in Sweden, whose names have become almost equally well known, although they were by no means equally great.

The Frenchman, George-Louis Le Clerc Buffon, the son of a counsellor of the parliament of Dijon, was born on his father's estate in Burgundy. The Swede, Karl Linnæus, the grandson of a peasant and son of a poor Swedish clergyman, was born in a small village called Râshult, in the south of Sweden. Buffon enjoyed the best education which France could afford him, with plenty of opportunity to cultivate his love of natural history. At one-and-twenty he succeeded to a handsome property, and after travelling for some time, settled down to a life of ease and literature, partly in Paris, and partly on his estate in Burgundy. Linnæus was taught in a small grammar-school, where he showed so little taste for books that his father would have apprenticed him to a shoemaker, if a physician named Rothmann, who saw the boy's love for natural history, had not taken him into his own house and taught him botany and physiology. At one-and-twenty, when Buffon came into his fortune, the

young Linnæus, with an allowance of eight pounds a year from his father, was a struggling student at the University of Upsala, putting folded paper into the soles of his old shoes to keep out the damp and cold.

**Buffon's Work on Natural History: he traces the Distribution of Animals.**—Buffon's private life is not interesting. He was a vain man, and not a moral one; but he had great talents, and remarkable perseverance and industry. In 1739 he was appointed Superintendent of the Royal Garden and Cabinet at Paris, a position which he held till his death. His great work, of which we must now speak, was his 'Natural History,' which occupied him during the greater part of his life. It is one comprehensive history of the living world, containing descriptions of all the animals then known, their structure, their distribution, their habits, and their instincts, and, mingled with these, many curious theories about the world and its inhabitants.

The anatomical part of this work was done by a physician named Daubenton, who came from Buffon's own village, and was appointed keeper of the cabinet of natural history through his influence. Buffon was very fortunate in having the help of this man, for having weak sight himself, and being more fond of general theories than of minute details, this part of his work would have been very poor if it had not been for Daubenton's careful and conscientious dissections and descriptions. The rest of the work was written chiefly by Buffon himself, who bestowed upon it immense pains and labour. He was a very pleasing writer, and did a great deal for natural history by making it popular. His books were more like romances than works of science, but he collected in them a great deal of very useful information, and put it in a shape which every one could read with pleasure, and in this way led people to think, and to wish to



know more about natural history and the habits and lives of animals. He was also the first to trace out with any care the way in which animals are distributed over different parts of the globe; how they are checked by climate, by mountains, by rivers, and by seas from wandering out of their own regions, and how they are more widely spread over cold countries than over warm ones, because they are able to cross the seas and rivers upon solid or floating ice, and so get from one region to another.

In this general way Buffon gathered together a great many interesting facts about animals. His works were all the more popular because he disliked anything like classification. He would not attempt to group the animals after any particular method, but liked to describe each one with a little history of its own, and to write on freely without any very great scientific accuracy. Of course the consequence was that he often made great mistakes, and arrived at false conclusions; still he had so much genius and knowledge that a great part of his work will always remain true, and Natural History owes a great deal to Buffon. He died in 1788, in the eighty-first year of his age, and twenty thousand people assembled to do him honour at his funeral.

**Life and Influence of Linnæus, 1707-1778.**—We must now turn to Linnæus, whose whole life and labours were as different from those of Buffon as his birth and early life had been. Buffon hated to be bound down to exact details; Linnæus found his greatest pleasure in tracing out each minute character in plants and animals so accurately as to be able to build up a complete classification, by which any one could tell at once to what part of the animal or vegetable kingdom any living being belonged. While Buffon's books were entertaining and readable, Linnæus's were often hard dry science, consisting chiefly of long accurate

tables and minute details about the structure of animals and plants. Yet Linnæus's writings are worth infinitely more than those of Buffon for one simple reason, he had a more earnest love of *truth*.

Linnæus seems to have been born a botanist. He writes in his own diary that when he was four years old he went to a garden party with his father and heard the guests discussing the names and properties of plants; he listened carefully to all he heard, and 'from that time never ceased harassing his father about the name, quality, and nature of every plant he met with,' so that his father was sometimes quite put out of humour by the incessant questioning. However at last, when Dr. Rothmann took him into his house, he had opportunities of learning, and from that time he advanced so rapidly that he was soon beyond all his teachers.

In 1736, after meeting with many kind friends in his poverty, and making a journey to Lapland, which was paid for by the Stockholm Academy of Science, he went to Holland. Here he called on the celebrated Boerhaave, who with his usual good nature introduced him to a rich banker, named Clifford, who was also a great botanist. This was the turning-point of Linnæus's life. Mr. Clifford invited him to live with him, treated him like a son, and allowed him to make free use of his magnificent horticultural garden. He also sent him to England to procure rare plants, and gave him a liberal income. It was at this time that Linnæus is said to have been so overcome by the sight of the mass of golden bloom on the furze at Putney Heath, that he fell upon his knees and thanked God for having created a plant of such wondrous beauty. Linnæus continued with Mr. Clifford for some time, till his health began to fail, and he found besides that he had learnt all he could in

this place, so he resolved to leave his kind friend and wander farther. Mr. Clifford seems to have been much hurt at his leaving, yet he continued his kindness to him through life.

Linnæus went to Leyden and Paris, and from there to Stockholm, where he practised as a physician, and at last he settled down as Professor of Medicine and Natural History at Upsala, where he founded a splendid botanical garden, which served as a model for many such gardens in other countries, such as the Jardin de Trianon in France, and Kew Gardens in England. His struggles with poverty were now over for ever, and his fame as a botanist was spread all over the world. He used to set out in the summer days with more than 200 pupils to collect plants and insects in the surrounding country, and many celebrated people came to Stockholm to attend Linnæus's 'Excursions.' Then as his pupils spread over the world he employed them to collect specimens of plants and animals from distant countries, and he himself worked incessantly to classify them into one great system.

**Linnæus gives Specific Names to Plants and Animals.**—And now we must try to seize upon the chief points of Linnæus's work, in order to understand something of what he did for science, although it is quite impossible in a book of this kind to give even a sketch of his divisions of the animal and vegetable kingdoms. The first and greatest point of all was that he gave a second or specific name to every plant and animal. Before his time botanists had only given one name to a set of plants; calling all roses, for example, by the name *Rosa*, and then adding a description to show which particular kind of rose was meant. Thus, for instance, for the Dog-rose they were obliged to say *Rosa, sylvestris vulgaris, flore odorato incarnato*, that is, 'common rose of the woods with a flesh-coloured sweet-

scented flower.' This, you will see, was extremely inconvenient ; it was as if all the children in a family were called only by their father's name, and you were obliged to describe each particular child every time you mentioned him ; as 'Smith with the dark hair,' or 'Smith with the long nose and short fingers,' etc. A botanist named Rivinus had suggested in 1690 that two names should be given to plants, and Linnæus was the first to act upon this idea and to give a *specific*, or, as he called it, *trivial* name to each particular kind of plant, describing the plant at the same time so accurately that any one who found it could decide at once to what species it belonged. To accomplish this he classified all plants, chiefly according to the number and arrangement of their stamens and pistils (or the pollen-bearing and seed-bearing parts), and then he subdivided them by the character and position of their leaves and other parts.

In describing the geranium, for example, he mentions first the 'sepals,' or little green leaves under the flower ; he says they are five, and very pointed ; then the 'petals,' or flower-leaves, are five also, growing on the sepals and heart-shaped ; the 'stamens' are ten in number, and grow separate ; the little vessels on the top of the stamens, which are called 'anthers,' and hold the yellow dust, are oblong ; the 'pistil,' or seed-vessel, is formed of five parts, which are joined together into one long beak ending in five points ; the seeds are covered with a skin and are shaped like a kidney, having often a long tip which is rolled round in a spiral (like a corkscrew). Here we have a definition of the *genus* geranium ; but many geraniums will answer to this description, so he goes on to describe some more special characters. The sepals in this particular specimen, he says, are joined together in one piece ; the stem of the plant is woody, the joints are fleshy, the leaves are slightly

feathered at the edge. These last characters are peculiar to this kind of geranium, which he calls *Geranium gibbosum*, and here we have the *specific* name. Any geranium which has the woody stem, the joined sepals, the fleshy joints, and the feathery-edged leaves, will be the species called by Linnæus *gibbosum*.

You will see that by this system it is always possible to find out easily to what part of the vegetable kingdom your plant belongs, and what its name is ; and if, after you have traced its genus, there is no species which exactly agrees with yours, you then know that you have discovered a new species which has not been described before. Linnæus classified animals after this same plan, quadrupeds chiefly by their teeth, and birds by their beaks and feet, and after his system was complete, any one could discover the scientific name of a plant or animal by exercising a little care and patience. This system is called the Linnæan or *artificial system*, because it only selects a few particular parts of a plant, so as to help you to look it out in a kind of dictionary. It tells you very little of the real or natural life of the plant, and often brings some very near together which are really very different. It is as if you classified people by some particular feature, such as those who had long hair, or short hair, dark or light, curly or straight. This might be very useful for recognising them, but it would be quite artificial, and would tell you very little about their real relationship. Therefore this classification has now been partly set aside for another or *natural* classification, which Linnæus also suggested, only he thought it too difficult for ordinary people ; and which was worked out by a French botanist named Jussieu, as we shall see by and by. But the Linnæan system is still extremely useful for finding the name of a plant or animal,

and many people in the last century were led to study zoology and botany by the simplicity of the classifications of Linnæus.

The other useful point in Linnæus's system was the accurate and precise terms he invented for describing plants. Before his time naturalists used any words which suited them, and as different people have often very different ideas as to what is meant by long or short, round or pointed, etc., the descriptions were often of very little value. But Linnæus could not work out his system without using very clear terms and explaining beforehand what he meant by them; and as his nomenclature, or system of names, was soon followed in other countries, botanists in all parts of the world were able to recognise at once what was meant by the description of any particular plant. The same advantage arose out of his classification of animals, and the care with which he traced out their chief characters. I wish I could have given you some idea of this system, which was fully explained in the 'Systema Naturæ,' completed in 1768. But when you remember that Linnæus classified minutely the whole of the animals and plants known in the world, you will perceive that it would be necessary to write a separate book to make it intelligible. If you can only remember that he did build up this artificial system, and that he was the first to give *specific* names to plants and animals and to create an accurate nomenclature all over the world, you will, I think, have learnt as much as you need know at present about the work of the great Swedish naturalist.

Linnæus was not a vigorous old man. The hard struggles of his youth and the immense work of his after-life had worn him out, and at fifty-six he was obliged to ask the King of Sweden to let his son lecture sometimes in his

place. With this help he continued to work at science till within two years of his death, when his mind became feeble. He died in 1778, loaded with honours and beloved and esteemed by the greatest men all over the world. His had been a noble life; enthusiastic and truth-loving, he had worked, even when he was poor, for science and not for wealth, and when he became famous and rich he helped his pupils as others had helped him, and lived simply and frugally till his death. Unlike Buffon, his private life was as pure as his public life was famous. Over the door of his room he placed the words '*Innocuè vivito, Numen adest*' ('Live innocently, God is present'), and he lived up to his motto. His study of nature had filled him with deep reverence and love for the Great Creator, and he used often to tell his friends how grateful he was to God for those gifts which had made his life so full of interest and delight.

After the death of Linnæus his family sold his collection of plants and insects, and all his books and manuscripts, to Dr. James Edward Smith (afterwards Sir J. E. Smith), for one thousand pounds. The King of Sweden was at this time away from Stockholm, but directly he returned and heard that such a valuable national treasure was on its way to England he sent a man-of-war to try and bring it back. A very amusing chase then took place; Dr. Smith did not mean to lose his prize if he could help it, so he set full sail and literally ran away till he reached the Thames, and landed safely in London without being caught. Thus the Linnæan collection came to England, and is now in Burlington House. The Swedes are naturally sorry that it left their country, but, on the other hand, it has become more known to scientific men in London than it could ever have been in Stockholm.

With Linnæus we must end for the present the history of the sciences relating to living beings. Early in the nineteenth century we shall return to them again, but in the next chapter we must learn something of a new science which arose about this time; namely, the science of 'Geology,' or the study of the earth.

---

*Chief Works consulted.*—Jardine's 'Naturalists' Library,' vols. ii. and xiii. ; Brewster's 'Encyclopædia'—'Buffon and Linnæus;' Cuvier, 'Histoire des Sciences Naturelles;' Smith, Sir J., 'Introduction to Botany;' Pulteney's 'View of Writings of Linnæus;' Linnæus, 'Systema Naturæ.'



## CHAPTER XXVI.

## SCIENCE OF THE EIGHTEENTH CENTURY (CONTINUED).

Prejudices concerning the Creation of the World—Attempts to Account for Buried Fossils—Palissy—Scilla—Woodward—Vallisneri—Lazzaro Moro—Werner—Disputes between the Neptunists and Vulcanists—Hutton—William Smith; His Geological Map of England.

**Early Prejudices concerning the Formation of the Rocks.**—You will no doubt remember that when we were speaking of the science of the Greeks, we learnt (p. 111) that Pythagoras made many interesting observations about the crust of the earth, which led him to say that the sea and land must have changed places more than once since the creation of the world. Especially he pointed out that sea-shells are found inland, deeply buried in the hills; and that the sea eats away land on the coast in some places, while in others earth is washed down by the rivers and laid at the bottom of the ocean.

We have now passed over more than 2000 years since the time of Pythagoras, and you will notice that we have heard nothing more about observations of this kind. The fact is, that during the Dark Ages the study of the earth had been almost entirely neglected, and people had taken up the mistaken notion that they ought to believe, as a matter of faith, that the world was created in the beginning just as we now see it. But knowledge and inquiry were advancing

so fast in the eighteenth century, that it was impossible for such ignorance to continue long. People could not go on digging wells and making mines in all parts of the world without being struck by the way in which the different *strata*, or layers of rock, are arranged in the earth's crust, nor without noticing the fossil shells, plants, and bones of animals which they found buried at great depths.

At first they were very unwilling to believe that these remains had ever belonged to living animals and plants, and they tried to imagine that they were only stones resembling shells, leaves, etc., which had been in some way mysteriously created in the earth. Then, when this absurd idea was given up, they next inquired whether a universal flood might not have spread them over the land; but though this opinion was upheld for more than a hundred years, yet it was clear to all those who really studied the subject that it could not account for the many layers of different fossils deeply buried in the earth.

**First Attempts to study the Fossil Remains and the Beds containing them.**—At last, little by little, there arose men who adopted the more sensible plan of studying the different formations in the crust of the earth before making theories about them. Bernard de Palissy, the maker of the famous French pottery, was the first to assert, in 1580, that the fossil shells were not only real sea-shells left by the waters of the ocean, but that they belonged to marine animals which had lived and died on the spots where they were found, and had not been strewn at random over the land by a deluge; then, in 1669, we find Steno, a Dane, writing a remarkable work on petrifications in the rocks; and in 1670 Scilla, an Italian painter, published a treatise on the fossil shells and other remains in the rocks of Calabria, and made some beautiful drawings of these remains, which may

now be seen in the Woodwardian Museum at Cambridge. Next we find our own scientific men—Hooke, the naturalist Ray, and a famous geologist Dr. Woodward—speculating why the earth's crust is made up of different layers, one above another, with different fossils in each; while Ray pointed out that a flood could not lay the fossil remains in great beds in particular places as they are found; but that there is every proof that the animals must have lived there for many succeeding generations. Woodward (1695) also made a careful collection of specimens of chalk, gravel, coal, marble, and other rocks, together with the fossils which he found in them; these are also in the Cambridge Museum. But all these men, though they did good work, still held many erroneous notions about the way in which the crust of the earth had been formed.

The first geologists who gave any real explanation of the facts were Vallisneri and his friend Lazzaro Moro, an Italian, born at Friuli in Lombardy, in 1687. Moro pointed out, as Woodward had done before him, that the different strata lie in a certain order one above the other, and that within them are imprisoned fossil fishes, shells, corals, and plants, in all countries, and at all heights above the sea. The rocks, said Moro, writing in 1740, must have been soft when these fossils were buried in them, and some must have been deposited by rivers; because they contain fresh-water animals and plants; while others contain only marine fossils, and must have been laid down under the sea. It is clear, then, that they must all have been formed in lakes or seas, and have been raised up by earthquakes, or thrown out by volcanoes, such as we see taking place from time to time in the world now. This explanation, though rough, was true, and Moro deserves to be remembered as one of the first men who led the way towards a true study of the earth. After

him there followed many others, whom we cannot mention here; but the next whose name is famous was the great Werner, professor of mineralogy at Freyberg in Saxony.

**Werner calls attention to Geology, 1775.**—Abraham Werner, the son of an inspector of mines in Silesia, was born in 1750. His first playthings were the bright minerals which his father's workmen gave him, so that he knew them by sight, even before he could tell their names; and as he grew up he seemed to care for nothing but mineralogy and the wonderful facts it revealed about the formation of the earth. Freyberg, when he first began to lecture there, in 1775, was only a small school for miners; but it was not long before he raised it to the rank of a university, so great was the fame of his lectures. He pointed out to those who came to learn of him, that the study of the rocks was something more than merely searching for minerals; and that the crust of the earth was full of wonderful histories, which might be read by those who cared to take the trouble. He pointed out how some formations were stratified, that is, arranged in layers, and contained fossil shells and other organic remains; while, on the other hand, some were unstratified, and had no fossils in them. Some rocks were bent, as in Fig. 37;

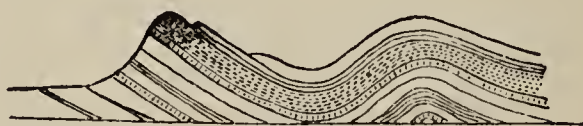

FIG. 37.

Diagram of Bent Rocks. (Page.)

others had been snapped asunder and forced one up and the other down, as in Fig. 38; and he bade them try to seek out the reason of these bendings and breakings of the earth's crust. He reminded them also that mining was one of the great roads to wealth, and that even the history of nations often depended upon the kind of ground which they had

under their feet. By facts such as these he opened men's eyes to see the wonders of the earth's crust, so that people began to talk everywhere of the geological lectures of Werner,

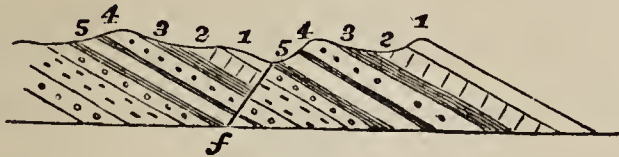

FIG. 38.

Diagram of rocks which have been rent apart at the point *f*, and tilted up. 1, 1, 2, 2, etc., Beds which before the disturbance were continuous.<sup>1</sup>

and numbers flocked from distant countries, and even learnt the German language, that they might come and hear him.

In this way he spread the love of geology all over Europe. He was so eager and earnest himself that his pupils could not fail to catch some of his enthusiasm, and to try to follow out his ideas. But, unfortunately, this very enthusiasm led him to insist upon a theory which kept back his favourite science for many years.

**Neptunists and Vulcanists.**—Werner had only studied a small part of Germany, and there were then very few descriptions of other parts of the world which he could read; and so, from want of knowledge, he formed the mistaken idea that in olden times, after the globe had cooled down and become fit for living beings, there were no volcanoes for long ages, but that basalt and other rocks, which we now know were made by volcanic heat, were all laid down by water. There were men living in Werner's time who knew that this was a wrong theory, but he would not listen to their arguments, and the two parties became so violent that many years were lost in angry disputes between the *Neptunists*, or those who thought all rocks were laid down by water, and the *Vulcanists*, who contended that many rocks, such as basalt, were made by volcanic heat.

<sup>1</sup> Kindly drawn for me by Professor Ramsay.

Hutton teaches that it is by the Study of Changes going on now that we can alone learn the History of the Past.—While these discussions were going on upon the Continent, a Scotchman was setting to work in the right way to settle the question. This man was Dr. Hutton, one of the greatest geologists that has ever lived; and the reason of his greatness was the same which we have found at every step in our history of science. Before he made any theory he sought out the *facts*. He travelled and observed for himself, he collected patiently details about the layers or strata in the formations of all countries through which he passed; and it was only after all these investigations that in 1788, when he was sixty years of age, he wrote his famous ‘Theory of the Earth,’ in which he showed how the history of the earth’s crust might be traced out. This work, although very interesting, was not much read; but one of Hutton’s favourite pupils, the celebrated Dr. Playfair, wrote a book called ‘Illustrations of the Huttonian Theory,’ by means of which Hutton’s opinions became well known.

About Hutton himself there is very little to tell. He was born in Edinburgh in 1726, studied medicine, and took his doctor’s degree in Leyden in 1749, and then returned to Edinburgh, and devoted all his life to science. Of his teaching I should like to write a great deal, but we must content ourselves with a little which can be easily understood. His great principle was that it was useless to try and *guess* how the rocks had been made and fossils buried in them, for this had only led to endless confusion and disputes. Men must go, he said, and see with their own eyes how different strata are being formed now, how rivers and glaciers are carrying down earth and stones from the mountains into the sea, and how volcanoes are throwing out melted matter which cools down into hard rock; and then

they must compare these with the older rocks in the crust of the earth, and see whether they were not formed in the same way.

**Aqueous (or water-made) Rocks.**—When we find a piece of marble made up almost entirely of oyster and other shells, and of pieces of coral, we cannot doubt that it must once have been a heap of loose shells and corals such as we now see on the shore or under the water, and that it has since been hardened into limestone. When we find that by crushing or scraping sandstone we can turn it into sand like that which we see on the seashore, and which we know has been made by the sea grinding the stones and rocks of the beach against each other, then we cannot doubt that the sandstone has once been loose sand, and before that was part of a rock which has been ground down by the waves.

And so we are led to the conclusion that the rocks of our earth, as we see them now, have been formed out of the materials of still older rocks which existed before them, and are being gradually moulded into other and newer rocks, which will exist when these have been destroyed. Our solid earth is being wasted every day. The sides of the mountains are washed down and their materials are carried through the valleys by the running water. In this way the soil is brought down to the coast, and here it is eaten away by the waves of the sea, and falls to the bottom of the ocean, out of which it will be raised again by earthquakes, volcanoes, and other movements of the earth's crust, such as can be proved to be going on in parts of the world at this day. As far back as investigations and reasoning can go we find everywhere signs that these gradual and incessant changes have always been going on, and that the face of our earth, as we now see it, has been moulded out of the ruins of an older world.

**Igneous (or heat-made) Rocks.**—But how are we to decide about those rocks, such as basalt, which Werner thought were made by water? Hutton was convinced they were formed in volcanoes; and yet it was true that they did not contain bubbles of air as lava does, which has poured down the sides of a volcano in the open air. Here his friend and pupil Sir James Hall came to his assistance by melting pieces of rock in his chemical laboratory, and letting them cool down under very heavy pressure. When this was done they could hardly be distinguished from pieces of basalt which he took out of the earth. It is clear, therefore, he said, that these rocks have either cooled down inside the volcano, with a great weight of rocks above them, or have been poured out under the sea, which would press down heavily upon them and shut out the air.

Another question which Hutton cleared up in the same way was that of the formation of granite. Werner believed that all the granite rocks, of which you may see plenty in different parts of the world, were made first, before any other rocks were laid down by water. Hutton did not think this was true, but that, on the contrary, granite might be even now forming deep down within the crust of the earth. But how was he to prove this? He said to himself, 'If melted granite forms under the softer strata which have been laid down by water, it ought occasionally to obtrude itself into them in narrow wedges when it is expanded by heat, and I shall be able somewhere to find veins of granite piercing the rocks above.'

To prove whether this was so he made a journey to the Grampians, where there are large masses of granite; and there, in Glen Tilt, he found the veins of red granite branching out into the clay-slate and limestone rocks above, as in Fig. 39. It is easy in this diagram to see that the



water-made layers, *a b*, must have been there before the granite was melted, otherwise it could not have sent the straggling veins, *c c*, up into them. And so he convinced himself that some granites are newer than the aqueous rocks

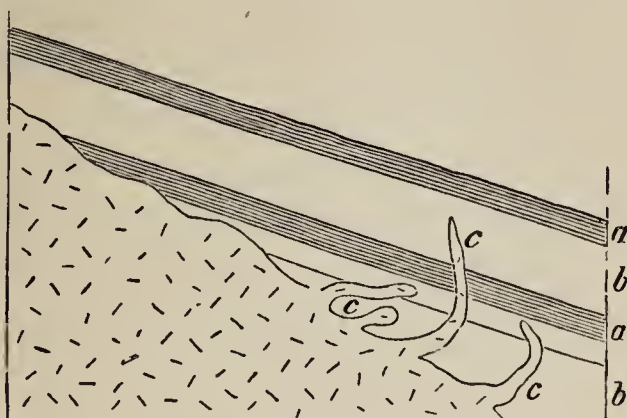

FIG. 39.

Granite Veins in Glen Tilt.

*a.* Clay slate. *b.* Limestone. *c.* Granite veins.

which lie above them. It is said that he was so delighted at finding this proof that the guides who were with him thought he had discovered a vein of gold.

This is one out of many examples of the way in which Hutton worked and corrected the mistakes which had sprung up in the German school of geology. Werner had taught his pupils that there was really something to be learnt from the study of the rocks; that they could be made to tell real histories of the past and help men to get wealth for the future, and thus he persuaded them to give time and thought to this work. Hutton showed that to carry on this study rightly they must open their eyes to all that is going on now, and that the only way to read the history of the past is to compare it with the present.

**William Smith surveys the Rocks of England.**—Meanwhile another man, whom we must not forget to mention, was working away very quietly without any help, and with very little money; and yet in his way was doing at least

as much work as the others. This was William Smith, a plain English surveyor, who was so much struck with the arrangement of the different formations in the hills among which he travelled that he determined to try and map them out so as to show exactly how the strata are placed one above the other, and what counties they pass through.

He began his work in 1790, and travelled over the whole country, chiefly on foot, marking as he went all the different positions of the rocks, and collecting the shells and other fossils which he found in them. He had not gone on long before he observed that certain fossils which appeared in the lower beds disappeared when he reached those which lay above them, and that others took their place; so that in this way it was possible to use the fossils to trace out the age of any particular rock, just as the face of a coin helps you to tell the reign in which it was cast; and the story told by the fossils agreed very well with the divisions which he had worked out by the position of the rocks above each other. He was even so observant that he distinguished between the fossils which had their edges fresh, showing that they had not been disturbed since they were buried in the earth, and those which were rubbed and water-worn. The fresh ones only, he said, are of use to tell the age of a rock, for those which are rubbed may have been washed out of some older formation by rivers.

In this way William Smith, for pure love of science, and without any hope of gain, travelled over the whole of England and Wales, mapping out the rocks and noticing all their peculiarities. In 1799 he published a list or tabular view of the formations with their fossils, and the places where they might be seen in the hills; and in 1815 he at last succeeded in completing a geological map of England, which has ever since formed the foundation of our British

---

geology, and which remains a lasting monument of what one man may accomplish by patience and indefatigable industry. William Smith fairly earned the title of the 'Father of English Geologists,' which has ever since been given him, and, with Werner and Hutton, deserves to be remembered as one of the founders of the science of geology.

---

*Chief Works consulted.*—Lyell's 'Principles of Geology;' Lyell's 'Student's Elements of Geology;' Page's 'Advanced Text-Book of Geology;' Hutton's 'Theory of the Earth;' Fitton's 'Notes on Progress of Geology in England;' 'Life of Werner'—'Naturalists' Library,' vol. xxxix.

## CHAPTER XXVII.

## SCIENCE OF THE EIGHTEENTH CENTURY (CONTINUED).

Birth of Modern Chemistry—Black—Bergmann—Cavendish—Priestley—Scheele—Rutherford—Lavoisier—French School of Chemistry.

DURING the last half of the eighteenth century, while Hunter and Linnæus were adding to our knowledge of living beings, and Werner and Hutton were reading the history of the crust of the earth, a little group of men in England, France, and Sweden were making discoveries which entirely altered the science of chemistry. These men were Bergmann and Scheele in Sweden ; Black, Cavendish, and Priestley in England ; and Lavoisier in France.

In order to understand what their discoveries were, and what they taught us, it is necessary to bear in mind that up to this time chemists had believed air and water to be elements or simple substances which could not be decomposed or split up into any other kind of matter. Mayow, indeed, had shown that the atmosphere could be separated into two gases, but his experiments had been passed over and forgotten ; and though Dr. Hales, at the beginning of the eighteenth century, had collected several gases, he had not distinguished them from air. The fact was that Stahl's 'phlogiston,' which was supposed to be a substance passing out of burning and breathing bodies into the air, was a constant source of confusion, and led men away from the truth.

But the time had now come when these misty ideas were to be dispelled, by the discovery of the four gases—carbonic acid, hydrogen, oxygen, and nitrogen.

**Discovery of 'Fixed Air,' or Carbonic Acid, by Black, 1756.**—The first step was made by a Scotch physician named Black, who was born of Irish and Scotch parents at Bordeaux in 1728, and became Professor of Chemistry at Glasgow in 1756. Here he made many valuable experiments, and among other things he was very anxious to find out why limestone altogether changes its character when it is burnt. If you take a piece of ordinary limestone or chalk, and put it in water, it will remain without any change unless you add a little acid to the water, and then the limestone will effervesce, and bubbles will begin to rise up from it. But if you take a piece of the same limestone and burn it in a fire, it turns into a powder called *quick-lime*, which will no longer give out bubbles when you pour acid upon it, but directly you mix it with water it will swell up and become intensely hot, as may be seen when bricklayers are making mortar by the roadside. This complete change in the limestone, caused by merely heating it, had been a great problem to chemists; and Dr. Black was still more puzzled by finding that the lime was lighter after it had been burnt, although he could not discover that it had lost anything except a little water, which was not enough to account for the loss of weight.

At last he remembered that Dr. Hales had driven air out of substances, and collected it in bottles; and he began to consider whether the heat of burning might not have driven some heavy kind of air out of the limestone, and so made it lighter. To prove this he made the experiment which has since been always used for making small quantities of carbonic acid gas. He put some pieces of limestone in the

bottle, *a*, Fig. 40, and poured upon them some water and some acid. He then stopped the bottle with a tight cork, and joined it by the tube *b* to a large glass jar, *c*, filled with water, and standing with its open end downwards in a vessel of water. Immediately bubbles began to rise from

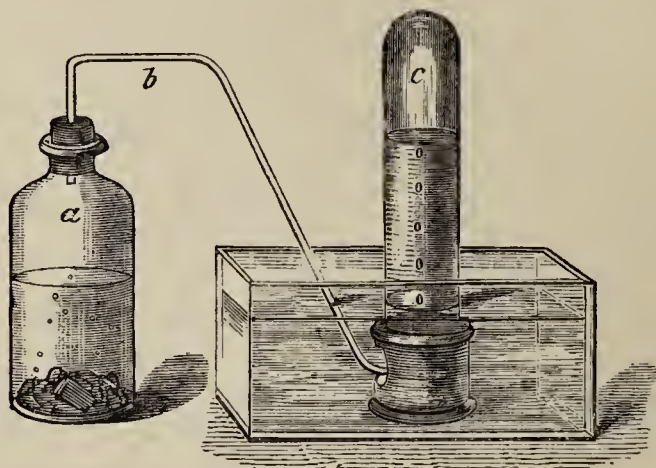

FIG. 40.

Carbonic Acid rising from Limestone and Acidulated Water (Griffin).

*a*, Bottle containing pieces of limestone in water and acid. *b*, Connecting tube.  
*c*, Inverted jar, out of which the rising gas is driving the water.

the limestone, and passing into the jar, *c*, drove out the water and filled the jar with gas.

This gas Black called 'fixed air,' because it had been fixed in the limestone before it was driven out by the acid. He collected and weighed it, and found that it *exactly made up the weight which the limestone had lost*. He then reversed the experiment, and taking some water, which had lime dissolved in it, he passed some 'fixed air' into it, and, as he expected, the gas joined itself to the lime and formed a powdered white chalk at the bottom of the bottle. By these two experiments he proved that limestone and chalk are composed of lime and 'fixed air,' and that lime can be turned into chalk by making fixed air to combine with it.

He then proceeded to examine the gas itself. He found that animals died in it, and that a flame would not burn in

it, and also that it was the same gas as that which bubbles out of beer and other liquids when they ferment, and often out of mineral springs. He also proved that there is 'fixed air' in our breath. This he showed by breathing into a glass of lime-water, and thus forming powdered chalk, which fell to the bottom of the glass.

All this Black discovered about 'carbonic acid,' which is sometimes called 'fixed air' even now, when people speak of it in effervescing drinks. He did not know that it is an acid; this discovery was made by Bergmann of Sweden, of whom we must now speak.

**Bergmann shows that Fixed Air is an Acid—Works out the 'Chemical Affinity' of many substances.**—Torbern Bergmann, who was born in 1735 in West Gothland, was the son of a tax-collector, and he had the greatest difficulty in getting permission to study science. His parents had intended him for the law or the church, and it was not until his scientific books had been burnt, and he had fallen ill with disappointment, that they saw it was useless to oppose him, and he was allowed to take his own course. From that time he was happy; he put himself under the great Linnæus, and in 1761 became Professor of Natural Philosophy at Upsala, and afterwards of Chemistry at Stockholm. Bergmann made a great advance in chemistry by working out the '*chemical affinity*' of many substances, and showing how to make use of it to *test* or try mineral waters.

Nearly a hundred years before Bergmann began to study chemistry, Newton, when writing on attraction, had pointed out that when substances are mixed together some kinds attract each other very strongly and join together, making one compound substance. For instance, he said, if you put copper into nitric acid the copper will dissolve and disappear; but if you plunge a piece of iron into the liquid the

copper will re-appear and fall to the bottom of the glass, because the iron attracts the nitric acid more strongly than the copper does, and so it takes it up out of the liquid, setting the copper free.

Chemists had till now neglected this observation of Newton's, but Bergmann followed it out, and by a number of experiments he drew up a table of those substances which seemed to have the greatest affinity for each other, and which would unite whenever the conditions would allow them. This he called a table of '*elective affinities*.'

It is easy to see how this could be used for testing or trying what substances lie hidden in mineral waters. Iron, for instance, in the case given by Newton, would show when copper was dissolved in a liquid containing nitric acid. Boyle, too, had shown that a blue liquid extracted from the lichen called *litmus* turns to a bright red directly it touches an acid; so that blue litmus is a sure *test* of an acid. Again, common salt put into a clear liquid containing silver, turns it cloudy; while tincture of gall-nuts makes a purple cloud in a solution containing iron. Bergmann worked out a number of these *tests*, and by means of them *analysed* or separated out the substances contained in mineral waters; he even dissolved solid minerals in acids and tested them in the same way.

One of the first uses that he made of his tests was to try Black's 'fixed air.' When he heard of this gas he suspected that it must be an *acid*, because it joined itself to lime, which is an *alkali*, that is, a substance in all respects unlike an acid; and he had found that unlike substances nearly always attract each other most strongly. So he made some 'fixed air' and tested it with blue litmus, and, as the litmus turned red directly, he knew that he was right in supposing it to be an acid, and he called it 'aërial acid,' or



acid air. He then weighed it and proved that it was bulk for bulk heavier than common air, and by passing it through water he showed that a quantity of it would dissolve.

Thus these two men, Black and Bergmann, had arrived at a pretty good knowledge of this gas. They had proved that it is an invisible heavy kind of air; that it dissolves in water; that it is acid and joins itself to lime, forming limestone or chalk; that it destroys life when breathed, and puts out a flame; that it is given out by fermenting liquids, and from mineral springs, and is contained in our breath. One thing they had not found out, namely, that it is made up of two elements; this was discovered by Lavoisier in 1779 (see p. 237), when he gave it the name of 'carbonic acid.'

**Discovery of Hydrogen by Cavendish, 1766.**—The next gas discovered was *hydrogen*, and its discoverer was Henry Cavendish, grandson of the Duke of Devonshire, who was born in 1731. Cavendish was a very shy and reserved man, who lived much alone, and found his greatest pleasure in studying science for its own sake. It is even related of him that he taught all his servants to understand by signs what he wanted in order that he might be able to think without interruption.

In the year 1766 he read a paper before the Royal society upon a gas which he called 'inflammable air,' because it burst into a flame whenever a light was brought near it, and also because he believed it to be the cause of the explosions which so often take place in mines. He obtained this gas by pouring sulphuric acid and water upon zinc, iron, or tin, and then collecting the bubbles as Black had done (see Fig. 40, page 226). But when he began to make experiments with this gas he found it very different from Black's 'fixed air.' It is true that a candle would not

burn, nor could animals live in it; but when a light was brought near it, it took fire and burnt with a pale blue flame inside the bottle. Then, instead of being heavy like 'fixed air,' it was lighter than the atmosphere, and for this reason it was soon used for filling balloons. It had also another remarkable peculiarity, that, when mixed with air in a bottle, it exploded with a loud noise directly a light was brought near it, leaving drops of moisture inside the bottle. Cavendish did not understand the cause of this explosion at first, but in 1784 (after Priestley had discovered oxygen) he mixed pure oxygen and hydrogen in a closed vessel, and lighted them by an electric spark, and then he made the great discovery that these two gases, when lighted, combine together and form *water*, which is therefore a compound substance made of oxygen and hydrogen.

**Oxygen discovered by Priestley in 1774, and by Scheele in 1775.**—The next gas discovered was oxygen, the most common and the most useful of all the substances in our globe. It was discovered independently by two men—Priestley, a dissenting minister at Leeds, and Scheele (born 1742), a small apothecary at Kjöping, a little village in Sweden.

There is no doubt that Scheele deserves as much credit for this discovery as if Priestley had never made it, for he had not heard of his experiments, and he added many useful facts which Priestley did not know. Still, as they both went over much the same ground, we cannot afford space here to give Scheele's experiments. You must not, however, forget his claim, for though the world often forgot him because he remained a poor apothecary all his life, yet Scheele was really one of the first chemists of Europe. We owe to him the discovery of chlorine; and of manganese, barytes, fluor-spar, and many other substances whose names I cannot

expect you to know. Indeed, his merit was so great that Bergmann, his friend and patron, once said, 'The greatest discovery he ever made was when he discovered Scheele.'

Joseph Priestley, the discoverer of oxygen, was born in 1733. The greater part of his life was spent in writing upon religious subjects, and it was only in his leisure hours that he studied chemistry. He tells us in his autobiography that he first began to take an interest in such things in consequence of visiting a brewery next door to his house and watching the fixed air which rose from the beer-vats. His first chemical experiment of any value was to force this 'fixed air' into pure water, thus making an effervescing drink, much the same as the soda-water we drink now. He next tried what effect growing plants have upon air, and by keeping a pot of mint under a bell-jar in which the air had been spoilt by burning or breathing, he proved that plants take up the bad air and render the remainder fit again to support a flame or life. He did not, however, yet know why this took place. He also invented a number of troughs and other apparatus for collecting and washing gases, and amused himself as Hales had done in driving gas out of different substances.

And thus it happened that one day, August 1, 1774, he made an experiment which led to a great discovery. He took a red powder called *mercuric oxide*, which he knew contained mercury and something else besides, and he put it into the bulb, *a*, Fig. 41; the rest of the tube he filled with mercury, and passed it into the basin *b*, and up into the jar *c*, both *b* and *c* being also filled with mercury. He next took a powerful burning-glass, *d*, and brought the rays of the sun to a focus upon the red powder. As soon as the powder became very hot a gas rose out of it and passed along the tube into the jar, *c*, driving out the mer-

cury; while the red colour began to disappear in the bulb, *a*, and only pure shining mercury remained behind. So far

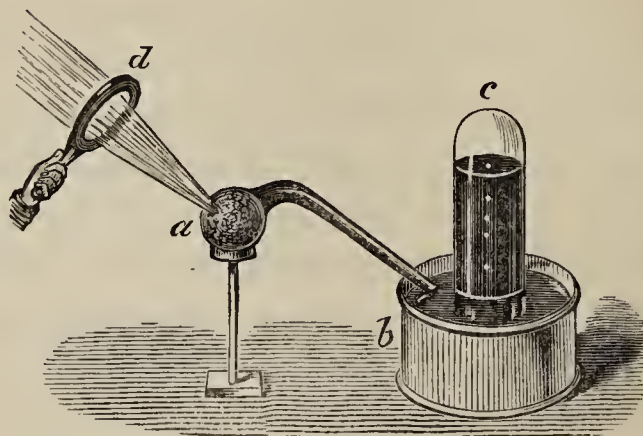

FIG. 41.

Priestley's Apparatus for procuring Oxygen.

*a*, Bulb containing red mercuric oxide. *b*, Vessel containing mercury. *c*, Inverted jar for collecting the gas. *d*, Burning glass.

he had only proved that red mercuric oxide is made up of mercury and a gas.

When he had collected enough gas to experiment upon he passed some of it through water, and found that it did not dissolve as 'fixed air' does; but what surprised him still more was that a candle put into it burnt with a large vigorous flame, and a piece of red-hot charcoal burnt in it furiously. It was clear, then, that this could not be either 'fixed air' or 'inflammable air,' for neither of these would feed a flame. He next put two mice into some of the gas, and he found that they lived much longer than in ordinary air. When he breathed it also into his own chest he felt singularly light and easy for some time afterwards. 'Who can tell,' he writes, 'whether this pure air may not at last become a fashionable luxury? As yet only two mice and myself have had the privilege of breathing it.'

Here, you see, we have come back again to Mayow's *fire-air*, so long forgotten, which supports life and flame. Priestley had learnt more about it than Mayow had, for he had collected it separately, had showed that it is the gas which supports combustion, and had breathed it without other air being mixed with it; moreover, he had shown that it could be driven out of metallic compounds, for mercury is a metal. Yet it is disappointing to learn that, in spite of having gone thus far, Priestley was so imbued with Stahl's theory of 'phlogiston,' that he did not really understand the great discovery he had made, but called his gas 'dephlogisticated air,' or air which had lost that imaginary 'phlogiston' which was always confusing men's minds.

There is no doubt that he discovered the gas and showed that it was the chief actor in combustion and respiration, and for this discovery and that of other gases, he was elected a member both of the Royal Society and of the Académie des Sciences, and his fame was great all over Europe; yet still he had not hit upon the entire truth—he had given the facts, and it remained for Lavoisier to read the riddle.

Besides his chemical writings, Priestley published many books on theology, and though he was a singularly gentle quiet man, yet his religious and political essays were often very severe, and they led to his being driven out of Birmingham, and his house burnt by the mob, when they attacked the leading Dissenters during the panic caused by the French Revolution. After living for some time near London he emigrated to America, where he died in 1804. He continued his chemical experiments up to the time of his death, and made many important discoveries, but the chief discovery which will always be connected with his name was that of *oxygen*, in 1774.

**Properties of Nitrogen determined by Dr. Rutherford in 1772.**—There now remains to be mentioned only one of the four gases spoken of at page 225, namely, *nitrogen*. This gas was first properly described by Dr. Rutherford in 1772, but there is very little to be said of it except that it has scarcely any of those properties which belong to the other gases. It does not support life or flame like oxygen; it does not make lime-water cloudy as carbonic acid does, nor does it burn like hydrogen. In fact, it is a dull sleepy gas, which remains after oxygen has been taken out of the air.

**Lavoisier lays the Foundation of Modern Chemistry, 1778.**—The determination of nitrogen completes the history of the discovery of those gases which play the chief part in combustion, respiration, and the maintenance of animal and vegetable life. But you will have noticed that we have not yet arrived at the new explanation of chemical changes which was to take the place of ‘phlogiston.’ The fact is that Bergmann, Cavendish, Scheele, and Priestley, were all so cramped by the old theory, that though they discovered the facts they could not make the right use of them. Black had, indeed, proved that fixed air would combine with lime (see p. 227), but he did not work out any theory of combustion from this discovery. The man who did this, and who laid the foundation of modern chemistry, was the celebrated French chemist, Lavoisier.<sup>1</sup>

<sup>1</sup> This statement having been questioned by one of the reviewers of the first edition of this book, it may be well to quote the words of Dr. Crum-Brown, upon whose advocacy of Black’s claims to precedence the objection was founded. After stating how Black ‘was the first to point out the new path,’ Dr. Brown continues, ‘We would be ungrateful if we undervalued the services of the French chemist. The facts

Antoine Laurent Lavoisier was born in Paris in 1743. His father, who was a wealthy merchant, gave him a splendid education, and when he was still quite young the new discoveries which were being made in chemistry tempted him to learn that science. At twenty-one years of age he received a gold medal from the Académie des Sciences for a very elaborate and learned essay on the best way of lighting the streets of Paris. At five-and-twenty he was elected a member of the Académie, and from that time he determined to devote his life to chemistry.

As early as 1770 Lavoisier had begun to suspect that the famous theory of phlogiston was false. His chief reason for thinking this was that he found, as Geber had done more than 900 years before (see p. 44), that when metals are heated so that they turn into powder, the powder weighs more than the original metal did before it was heated. Moreover, he also found that the air which remained behind in the vessel in which the metal had been heated had *lost exactly as much weight as the metal had gained*. So it seemed to him clear that the metal must have taken something *from* the air instead of giving anything to it.

For eight years Lavoisier worked incessantly at this problem. He heated many metals, such as iron, lead, tin, etc., and other substances such as sulphur and phosphorus, and in every case, if he collected all that remained, he found it heavier than before. But there was one point in which he could not succeed; he could not make the metals give back again what they had taken from the air, so that he might examine it. At last, in 1778, it occurred to him that Priestley had separated mercuric oxide into two substances; discovered by Priestley, Scheele, and Cavendish, were merely the raw material out of which Lavoisier constructed a consistent and comprehensive theory.' Inaugural Lecture, Edinburgh, 1869.

namely, the metal mercury and a gas. Here, then, was just the step he wanted. If he could first make mercuric oxide by heating mercury in the air, and then afterwards separate it back again into mercury and a gas, he would thus prove what it had taken out of the air. He therefore took some mercury and put it into a tube A, Fig. 42, which was connected

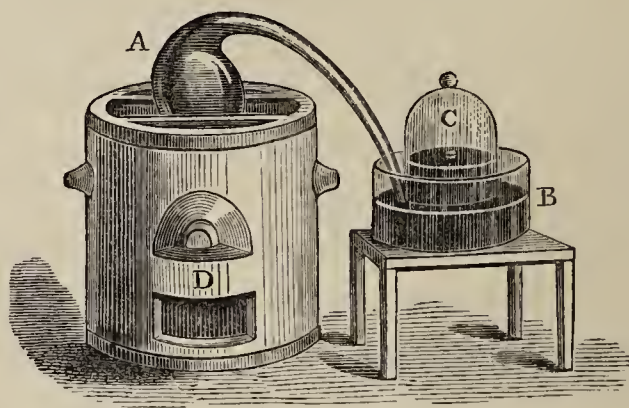

Fig. 42.

Lavoisier's Apparatus for Heating Mercury and making it take up Oxygen.  
 A, Bulb containing mercury. B, Vessel containing mercury. C, Bell-jar partly full of air. D, Stove.

with a bell-jar c, containing air and standing over mercury. Then he heated the bulb A over the stove D, and kept the mercury boiling for twelve days.

During the first five days little by little red specks began to appear on the top of the mercury in c, that is, mercuric oxide was formed; but after that time, when about one-fifth of the air in the bell-jar, c, had disappeared and mercury risen in its place, no further change took place. He then lifted off the bell-jar and took 45 grains of this red powder and made Priestley's experiment with it (see p. 232), and he obtained, of course, the gas which Priestley had called 'dephlogisticated air.' He afterwards found by more exact experiments that the amount of this gas contained in the mercuric oxide exactly equalled the amount lost by the air in which the mercury had been heated.



Now see what Lavoisier had done : he had proved that the reason why air shrinks when substances are burnt in it, is because *the substances take up a gas out of the air*, and he had also shown that this gas is the same as that which Priestley discovered. Now, at last, the false theory was destroyed, and the starting-point of a true theory was found. The imaginary phlogiston, which had been supposed to load the air when anything was burnt in it, was proved never to have had any existence ; for it was clear that just the opposite effect takes place. *All burning and breathing and the change in metals is caused by a gas being taken up out of the air and joined to other substances.* Lavoisier called this gas *oxygen* (from ὀξύς, acid ; γεννάω, I produce), because he found that most substances were acid after they had been united with it. This, too, led him to suspect that as 'fixed air' was an acid, and could be made by burning charcoal, it must be composed of oxygen and carbon. So he burnt small quantities of charcoal in pure oxygen, and by analysing the 'fixed air' produced proved that 100 parts by weight of this gas contained 72 parts of oxygen and 28 of carbon. For this reason he called it 'carbonic acid,' a name which it still bears. By burning a diamond in oxygen and producing carbonic acid, he also proved that a diamond is pure carbon.

Lavoisier had very great difficulty in persuading the other leading chemists that they had been labouring under a false idea, and that substances when burning do not put something into the atmosphere but take a gas out of it. Dr. Black was one of the first to teach the new theory, as was natural, since he had led the way to it by the experiments he had made with 'fixed air,' but Priestley died without giving up his old opinions. The younger chemists, however, saw the truth of Lavoisier's explana-

tion, and from this time chemistry advanced very rapidly. Lavoisier invented an entirely new set of terms instead of the old names of the alchemists, and though his terms have been greatly altered by later discoveries, still many of them will always be used. He repeated with a better apparatus Cavendish's experiment of turning hydrogen and oxygen into water, and he gave *hydrogen* its name from ὕδωρ, water, and γεννάω, I produce. Lastly, he published his 'Elements of Chemistry,' in which he gave a clear explanation of the different chemical changes, and how students could work them out for themselves.

Lavoisier was now at the height of his fame, full of his new theory, and prepared to devote the rest of his life to making chemistry a grand science; but a very sad fate was awaiting him. In 1793 the great French Revolution broke out in Paris. Lavoisier was a farmer-general, that is a kind of collector of taxes, and all the farmers-general were hated by the people; so he knew that he should most likely lose all his fortune, and was prepared to work for his living; but he had not expected the blow which fell upon him. All the farmers-general were condemned to death, and though a physician named Hallé, who deserves always to be remembered for this act, pleaded that Lavoisier's life should be spared till he had completed his experiments, the ignorant and brutal Government replied, 'We do not need learned men,' and on May 18, 1794, at the age of fifty-one, Lavoisier was guillotined.

After his death the French School of Chemistry, took the lead for many years, until new discoveries in England, which we shall mention by and by, made another great advance. When you are able to read larger works upon the history of chemistry you will find how very interesting the period was of which we have been speaking. I have only been able to

---

give you here the very barest outline of it, so that the names of these great chemists may not be quite unfamiliar when you meet with them in other books.

---

*Chief Works consulted.*—‘Three Papers on Factitious Air,’ by Cavendish—‘Phil. Trans.,’ 1766; Brande’s ‘Chemistry;’ Hoefler’s ‘Histoire de la Chimie;’ Cuvier, ‘Histoire des Sciences Naturelles;’ Huxley, ‘On Priestley’—‘Macmillan’s Magazine,’ 1874; Priestley, ‘On Different Kinds of Air,’ 1774; Thomson’s ‘Hist. of Royal Society;’ Scheele’s ‘Chemical Experiments on Air and Fire,’ translated 1780; Miller’s ‘Elements of Chémistry;’ Lavoisier’s ‘Elements of Chemistry,’ translated by Kerr, 1790.

## CHAPTER XXVIII.

## SCIENCE OF THE EIGHTEENTH CENTURY (CONTINUED).

Dr. Black on Latent Heat—Watt's Application of the Theory to the Steam-engine—Early History of Steam-engines—Newcomen's Engine—Watt's Engine—Watt and Boulton.

**Discovery of Latent Heat by Dr. Black in 1760.**—We must now go back a few years, to the time when Dr. Black was lecturing at Glasgow in 1760; for he then made a remarkable discovery about heat, which belongs to the history of physics rather than of chemistry. This was the discovery of *latent heat*, or of heat which becomes lost or *hidden* whenever a solid is turned into a liquid, or a liquid into a gas.

If you put a lump of ice in a saucepan on a stove, and when it begins to melt stir it gently so as to keep the water well mixed, you will find that so long as the smallest piece of ice is left in the water, a thermometer standing in the saucepan will not rise higher than  $0^{\circ}$  Centigrade, or the melting-point of ice. Now the heat from the stove must be continually entering the water, otherwise the ice would not melt. What then becomes of this heat? Again, if you keep the water on the stove after the ice is melted, it will grow hotter and hotter till it reaches  $100^{\circ}$  Centigrade, when it will boil. Here, again, it will remain at the same temperature, and though you go on boiling it till it has all passed away in steam, the last drop of water will never be hotter than  $100^{\circ}$  C. So

that here again the heat which is added remains hidden and does not become apparent. This last fact about boiling water had been long known to philosophers, but no one found any explanation of it until Black began his experiments on melting ice; and he then came to the conclusion that the heat is employed in altering the condition of the water, that is, in changing it, in the one case from solid ice into water, and in the other from water into a vapour.

He proved this by some simple experiments which are not difficult to make. He took two glass flasks, and filled one with ice just on the point of melting, and the other with an equal weight of ice-cold water. These he hung in a moderately warm room, which he kept all the time at the same heat ( $8^{\circ}5$  C.). At the end of half an hour the ice-cold water had risen four degrees (from  $0^{\circ}$  to  $4^{\circ}$ ), but the melting ice remained at  $0^{\circ}$ , and it was ten hours and a half before the ice had disappeared, and the water had reached the same temperature as that which the water in the other basin had attained in half an hour. Now the melting ice had been receiving heat for twenty-one half-hours, and therefore had taken in  $21 \times 4$ , or  $84^{\circ}$  of heat, while it only showed a rise of  $4^{\circ}$ . It was clear, therefore, that the remaining  $80^{\circ}$  must have been spent in turning the ice into water.

Black now tried the same thing in another way. He found that a pound of water at  $79^{\circ}$  C. would exactly melt a pound of ice. So he again took two vessels, in one of which he put a pound of *ice-cold water* at  $0^{\circ}$ , and a pound of hot water at  $79^{\circ}$ , and when they were properly mixed he found, as he expected, that the heat of the mixture was half-way between the two, that is  $39\frac{1}{2}^{\circ}$ . In the other vessel he put a pound of *ice* at  $0^{\circ}$ , and a pound of hot water at  $79^{\circ}$ , and here, when the ice had disappeared, the

mixture still remained at  $0^{\circ}$ , showing that the whole  $79^{\circ}$  of heat in the boiling water had been absorbed in melting the ice, and remained hidden or *latent* in the two pounds of water. The *latent heat* of water is therefore between  $79^{\circ}$  and  $80^{\circ}$ .

We know now what becomes of this heat, as you will see (Chapter XXXV.) in the history of the science of the nineteenth century; but the first step was to prove its disappearance into the water, and this we owe to Black; as well as the fact that still more heat is lost in turning water into steam.

This last fact he proved by filling a glass bottle half full of water, corking it very tightly, and then heating the bottle till the water began to boil. He was obliged to do this very gently, because the outward pressure of steam increases very rapidly as the temperature rises, and he did not wish to drive out the cork or break his bottle. After a little time the water ceased boiling, because the other half of the bottle was full of steam, and there was no room for more to form. But now the water began to grow hotter and hotter, and rose above  $100^{\circ}$  C., showing that when the heat could no longer form steam it did not remain hidden, but increased the temperature of the water. At last, when he was afraid to heat the bottle any more, he loosened the cork, which flew out with great violence, followed by a cloud of steam. And now notice what happened; directly the rush of steam was over, the heat of the water in the bottle fell again to  $100^{\circ}$  C., for *all the rest of the heat had been used in forming more steam* the moment the pressure was removed.

**James Watt, 1736-1819.**—Black had now completed his discovery, and from that time he taught in all his lectures that heat becomes *latent* or absorbed when a solid

is changed into a liquid, or a liquid into vapour. It was about this time that the famous engineer, James Watt, began to study the power of steam, and as Black was his friend, he came to him to help him solve his difficulties. The history of the steam-engine, being the history of an invention, does not strictly belong to our work; but the use which Watt made of the discoveries about steam is a part of science, and we must therefore find room for a slight sketch of it here.

James Watt was born at Greenock in 1736; he was the son of a builder and shipwright, and was so delicate as a child that he was kept at home, and learnt reading from his mother, and writing and arithmetic from his father. When at last he was sent to school he found it hard work, for he was slow and thoughtful, and the other children jeered at him for his want of quickness. Every one knows the story of his being scolded by his aunt for sitting silent a whole hour, holding first a spoon and then a saucer over the steam rising from a kettle, and watching the drops of water gathering upon them. It was in this quiet way that little James's mind grew, and it may be an encouragement to slow, plodding boys to know that one of our greatest inventors was considered a dull and backward child.

As he grew older James went up to London, and there, after overcoming many obstacles, which the guilds, or trades' unions of those days, put in the way of all independent workers, he learnt to make mathematical instruments, and then returned to Glasgow, where he began business. Though he was only one-and-twenty he soon became known as a man of unusual ability, for the mind of the dull boy had developed, and his thoughtfulness had begun to produce results. Not only the students, but even the professors of the University used to stroll into his little shop to discuss

the discoveries of the day. 'Whenever any difficulty arrested us,' writes a student named Robison, 'we used to run to our workman, and he never let go his hold until he had entirely cleared up the proposed question.' One day it was necessary to read a German book on mechanics; Watt immediately set to work and learnt German, and another time, for the same reason, he studied the Italian language. It is scarcely surprising that a man with such talent and perseverance as this, who was also gentle and loving to everybody, should be sought after both by masters and students.

Among those who came to Watt's shop was one Anderson, professor of physics, who, finding that a little model of a steam-engine in the University museum was out of order, brought it to Watt to be repaired, and thus led the way to his invention. And here it is necessary to point out two things: *First*, you must not suppose that by a steam-engine is meant a railway engine; all contrivances which move by the power of steam are *steam-engines*, and locomotive engines which draw carriages were not made till 1804, long after Watt's time. *Secondly*, you must get rid of the idea, which many people have, that Watt was the first man to make an engine which moved by steam. This was done long before his time. The thing which Watt really did was to make an engine such as we now use, working *entirely* by steam, without the help of air, and doing an enormously greater amount of work with the same quantity of fuel than any others had done before.

**The Newcomen Engine, 1705.**—Steam had been used to turn a globe by Hero of Alexandria, a Greek who lived 120 years before Christ; and Baptiste Porta in 1580, Solomon de Caus in 1615, and the Marquis of Worcester in 1663, all tried to make use of steam to do work. Again,





at one end of the beam, and the weight of the lump of iron,  $e$ , at the other end.

The lever-beam of this engine is balanced in such a way that when it is not at work the weight  $e$  pulls it down on the side away from the engine, and the piston,  $p$ ,  $p$ , is drawn up to the top of the cylinder, as in the figure. To set the engine going a fire is lighted under the boiler, and the tap or stopcock,  $a$ , is opened, so that the steam rises into the cylinder, driving out the air through the air-vent,  $c$ . As soon as the cylinder is full of steam,  $a$  is turned off, and the stopcock,  $b$ , turned on. Immediately a small jet of cold water from the tank  $T$  rushes through  $b$  into the cylinder, turning the steam back into a few drops of water, which flow out with the cold water down the pipe  $d$ . Now notice, the *cylinder is quite empty*; for the steam drove out the air, and the cold water carried the steam away with it, while no air can come in at  $c$  or  $d$ , because the little valves in them are kept shut by the weight of the atmosphere outside. So there is nothing to hold up the piston, which is being heavily pressed down by the air above it. The consequence is, down it comes to the bottom of the cylinder, dragging with it the end of the lever-beam. Directly it reaches the bottom the stopcock  $b$  has to be shut, and  $a$  opened again. Up rises the steam directly from the boiler, driving up the piston, and the whole thing begins again. In this way the lever-beam is kept moving up and down by simply turning the two stopcocks one after the other. These were at first opened and shut by boys; but one day an ingenious lad named Humphrey Potter, who wanted to save himself the trouble of turning the cocks, found that by tying strings from the handles to the different ends of the beam he could make the engine open its own cocks as the beam went up and down. This rough arrangement was soon improved, and the machine worked by itself.

**Watt's Separate Condenser.**—Such was the engine as Watt found it. When he began to examine it, he saw at once what an immense quantity of heat was wasted. Every time the piston came down, the cylinder, as well as the steam in it, had to be cooled down; every time the piston rose, the cylinder had to be heated again; and the thing which puzzled him most about it was, that it took six pounds of cold water to condense only one pound of steam.

It was in this difficulty that he came to Dr. Black, and learnt from him the theory of *latent heat*, which showed that there is an immense store of heat hidden in steam, which has to be drawn out before it can become water. This was an entirely new light to Watt, and it led him to make many experiments still more exact than those of Dr. Black, which convinced him that no engine would ever work well or economically, while so much power was wasted in cooling and re-heating the cylinder at every stroke. But how was he to cool down the steam without cooling the cylinder which held it?

For months he pondered over this without finding any answer. At last, one Sunday afternoon, when he was walking on the Green of Glasgow, the way to do it flashed upon his mind. *If he could draw the steam off into a separate vessel and condense it there, the cylinder might still be kept hot, and the thing would be done.* Fig. 44 will help you to understand how this could be effected. Here the two flasks, A and B, are first quite emptied of air, and B is half filled with water. Under B is placed a lamp, D; under A, a basin of ice, E. Now as long as the tap, c, is kept open, the steam which is constantly rising from the water in B will rush along the tube into the empty flask, A, and will there be turned into drops of water by the cold of the ice underneath, and this will go on as long as there is any water left in B,

because there will always be an empty space or vacuum in A to receive the steam as it rises. When the tap, c, is shut, the steam in B will become very dense, and when it is opened again, the greater part of the steam will rush out and be cooled down in A, while B remains hot as before.

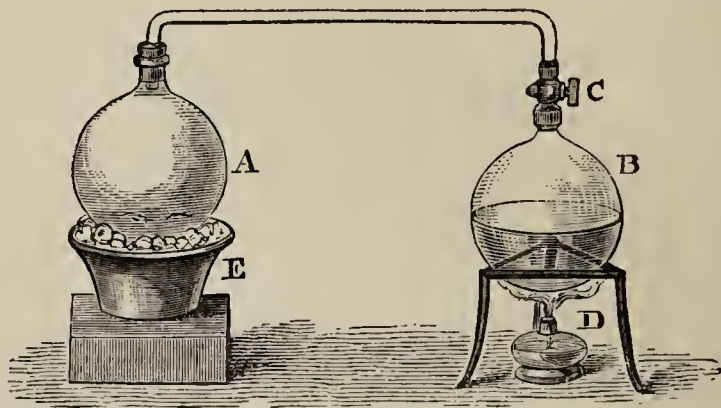

FIG. 44.

Steam condensed in a separate vessel.

A, Flask empty of air. B, Flask half-full of water and empty of air. c, Tap connecting the two bottles. D, Spirit-lamp keeping the water in B boiling. E, Basin of ice cooling down the steam which passes into A.

**Watt's Engine.**—This was exactly the plan Watt adopted in his steam-engine; B answers to his cylinder (Fig. 45), which could be kept always hot, and A to his condenser, in which his steam was turned back into water. We cannot follow out all the different steps of his invention, and must content ourselves with a rough description of his engine after he had completed it, as shown in Fig. 45.

In the first place you must notice that cold water is kept flowing down from the tank A into B, and out through the pipe c, so that the condenser standing inside B is kept quite cold; and, secondly, I must tell you that the rods, 1 and 2, are so placed that when the engine-end of the lever-beam is raised, as in the figure, the stopcocks *a* and *c* are open, and *b* and *d* are shut; and when that end of the beam falls, *b* and *d* will be open, and *a* and *c* will be shut.

Let us now begin with the machine as we see it in the figure. In this position of the beam the cocks *a* and *c* are open; therefore, the steam below the piston will rush out at *c* into the condenser, there to be turned into drops of

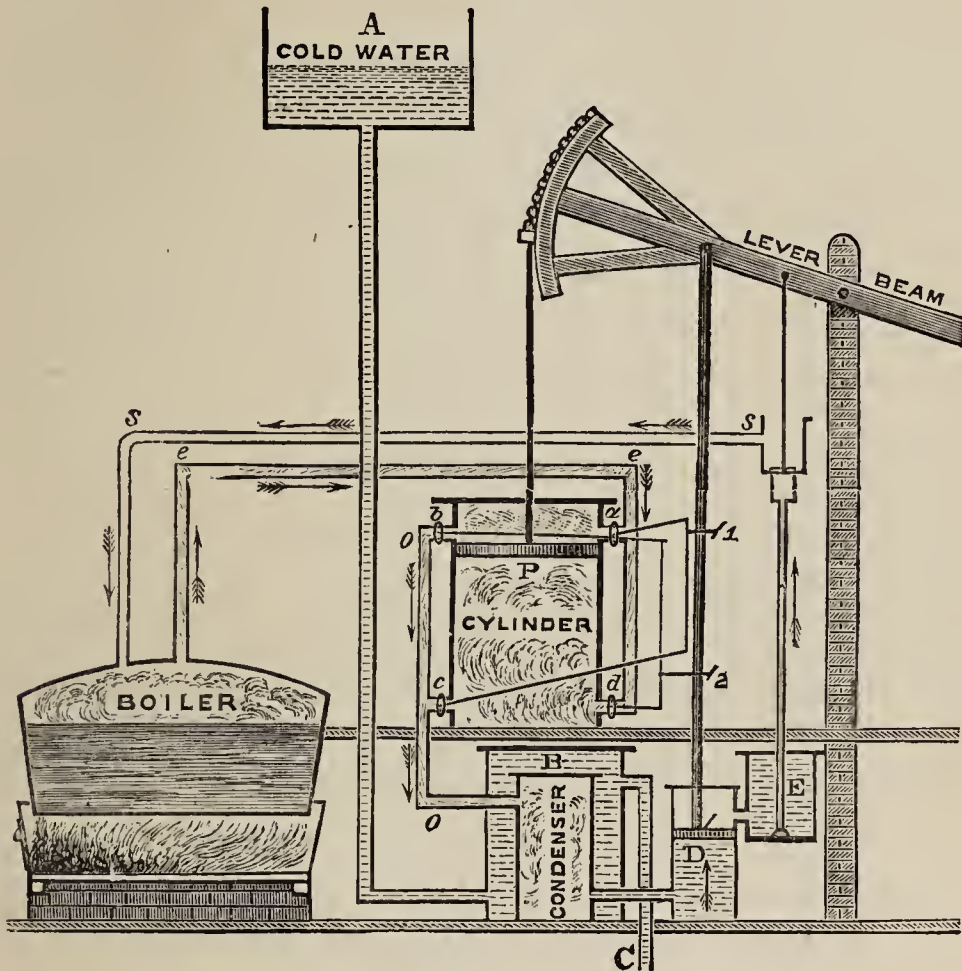

FIG. 45.

A, B, Cold water tanks. c, Outlet for cold water. D, E, Pumps for drawing off hot water and sending it along *s, s*, back to the boiler. P, Tight-fitting piston. *a, d*, Cocks for letting steam into the cylinder. *b, c*, Cocks for letting steam out of the cylinder. *e, e*, Pipe which carries steam from boiler to cylinder. *o, o*, Pipe which carries steam from cylinder to condenser. 1, 2, Rods connecting the cocks with the lever-beam.

water, while the steam from the boiler, entering at *a*, will force the piston down. But now, the piston having pulled down the beam, *a* and *c* will be closed and the other two cocks, *b* and *d*, will be opened. So the steam above the piston will rush out at *b* into the condenser, while the steam

from the boiler will pass directly from *e* down to *d*, and coming in *below* the piston, will drive it *up* again. In this way, although the cylinder is never cooled, the piston moves steadily up and down; because the steam is driven off into the condenser standing in B, where it is turned into water, and is drawn up by the two pumps D and E, and sent along the pipe, *s, s*, back to the boiler.

This was the principle of Watt's double-acting steam-engine, and if you understand the difference between Figs. 43 and 45, you will see that though Watt was not the first to make engines move by steam, he was the first to make a pure *steam-engine*, where the piston moves up and down without any help from the outside air, or of the counterbalancing weight *e*, Fig. 43, and without the enormous waste of heat and fuel which made all the earlier engines comparatively useless.

I have only attempted to explain the way in which he applied steam to his engines; all the numberless other improvements which he made must be studied in books on engineering. For twenty long years he went on improving and inventing without reaping any reward for his labour. Other men tried to steal his ideas and to make a profit out of his genius, and he had to fight against prejudice and injustice, and against constant depression caused by his own ill-health. Yet he found many kind friends upon his road, and amongst the most famous of these was Boulton, the Birmingham manufacturer, who became his partner in 1769, and stood by him manfully in all his difficulties and troubles. It was from Boulton's manufactory at Soho (a suburb of Birmingham) that Watt's engines went forth to the world, and worked that great change in the manufactories of England which has made us one of the first nations of the world.

---

The names of Boulton and Watt deserve to be classed together as benefactors of mankind. Watt was the inventor, the man who loved science, and who could not live without creating. Boulton was the large-minded, enterprising man of business ; he gave Watt men, money, courage, and support to carry out his inventions ; and by his sympathy with, and command over, the workmen, he led the army which conquered indifference, persecution, and difficulties, and established steam machinery in all the workshops of the world. Watt died in 1819, in the eighty-third year of his age, and was buried in Handsworth Church, near his friend and partner Boulton, who had died ten years before.

---

*Chief Works consulted.*—Black's 'Elements of Chemistry,' 1803; 'Edinburgh Review,' vol. xiii. 'History of Steam Engines;' 'Arago, Biographies of Scientific Men,' 1857; Smiles's 'Lives of Boulton and Watt;' Everett's Deschanel's 'Natural Philosophy;' Tyndall's 'Natural Philosophy;' Balfour Stewart's 'Treatise on Heat;' Beckmann's 'History of Inventions.'

## CHAPTER XXIX.

## SCIENCE OF THE EIGHTEENTH CENTURY (CONTINUED).

Benjamin Franklin, born 1706—His Early Life—Du Faye discovers two kinds of Electricity—Franklin proves that Electricity exists in all bodies, and is only developed by Friction—Positive and Negative Electricity—Franklin draws down Electricity from the Sky—Invents Lightning-conductors—Discovery of Animal Electricity by Galvani—Controversy between Galvani and Volta—Volta proves that Electricity can be produced by the Contact of two Metals—Electrical Batteries—The Crown of Cups—The Voltaic Pile.

**Benjamin Franklin, born 1706.—He Investigates the Nature of Electricity, 1746.**—Benjamin Franklin, the printer and man of science, was born at Boston, in America, in the year 1706. He was the son of a tallow-chandler, and had so many hard struggles in his early life that he does not seem to have turned his thoughts to science till he was nearly forty years of age. His father intended him for the Church, but there was not enough money to pay for his education, so he was apprenticed to his brother, who was a printer. Here he worked very hard, yet he used to snatch every spare moment to read any books which came within his reach; but his brother being unkind and harsh to him, a quarrel sprang up between them, and Benjamin at last ran away to New York, and from there to Philadelphia. In this last place he got a little work, but hoping to do better in England, he came to London, where



he learnt many of the newest improvements in printing. After a time he went back to Philadelphia, and from that time he began to succeed as a printer, and became a well-known and respected man.

It was in the year 1746 that he first began to pay attention to the experiments in electricity which were being made in England and France. A great deal had been learnt about this science since the time when Otto Guericke made the first electrical machine in 1672, and a Frenchman named Du Faye had shown that two different kinds of electricity could be produced by rubbing different substances. You will remember that a pith-ball, when charged with electricity from a stick of electrified sealing-wax, draws back, and will not approach the sealing-wax again (see p. 122). But Du Faye discovered that if you rub the end of a glass rod with silk, and bring it near to this ball, it will draw the ball towards itself, showing that the electricity in the glass rod has exactly the opposite effect to that in the sealing-wax. In other words, while Guericke had shown that substances charged with the *same* kind of electricity *repel* each other, Du Faye showed that substances charged with *different* kinds of electricity *attract* each other. Both these men thought that electricity was a fluid which was created by the rubbing, and which was not in bodies at other times; when Franklin, however, began to make his experiments, he came to the conclusion that this was not as they had supposed, but that all bodies have more or less electricity in them, which the rubbing only brings out.

The way in which he proved this is very interesting; but to understand it you must first know that any body which is to be electrified requires to be so placed that the electricity cannot pass away from it into the earth. The best way to do this is to place it upon a stool with glass

legs, because electricity does not pass easily along glass. You must also know that when any substance is charged with electricity, if you bring your finger or a piece of metal near to it, a spark will pass between the electrified substance and your finger or the metal.

You will now, I think, be able to follow Franklin's experiments. He put a person, whom we will call A, upon a glass stool, and made him rub the glass cylinder of an electrical machine with one hand and place his other hand upon it to receive the electricity. Now, he said, if electricity is *created* by the rubbing, this person must be filled with it, for he will be constantly taking it from the machine, and it cannot pass away, because of the glass legs under the stool. But he found that A had no more electricity in him after rubbing the cylinder than he had before, neither could any sparks be drawn out of him. He then took two people, A and B, and placing each of them on a glass stool, made A rub the cylinder, and B touch it, so as to receive the electricity. Now notice carefully what happened. B was soon so full of electricity that when Franklin touched him, sparks came out at all points ; but what was still more curious, when Franklin went to A and touched him, sparks came out between them just as they had done between him and B.

This he explained as follows : ' A, B, and myself,' he said, ' have all our natural quantity of electricity. Now when A rubbed the tube, he gave up some of his electricity to it, and this B took, so that A had lost half his electricity and B had more than his share. I then touched B, and his extra charge of electricity passed into me and ran away into the earth. I now went to A, and I had more electricity in me than he had, because he had lost half his natural quantity, and so part of my electricity passed into him, producing the sparks as before.'

This Franklin believed to be the case with all electricity, namely, that every body contains its own amount of it, but that when for any reason it is distributed unequally, those which have no more than they can well carry, give some up to those which have less, till they have each their right quantity. And this explained at once why a man cannot electrify himself, for so long as he has no one else from whom he can procure electricity, he is only taking back with one hand what he gives out with the other. Those who had too much electricity were called by Franklin *positively electrified*, and those who had too little, *negatively electrified*, but the terms *positive* and *negative* are now used differently, the one for *vitreous* the other for *resinous* electricity.

**Franklin draws down Lightning from the Sky.**—It was in 1749, when he had already made most of his experiments upon electricity, that Dr. Franklin began to consider how many of the effects of thunder and lightning were the same as those which he could produce with his electrical machines. Lightning travels in a zigzag line, said he, and so does an electric spark; electricity sets things on fire, so does lightning; electricity melts metals, so does lightning. Animals can be killed by both, and both cause blindness; electricity always finds its way along the best conductor, or the substance which carries it most easily, so does lightning; pointed bodies attract the electric spark, and in the same way lightning strikes spires, and trees, and mountain tops. Is it not most likely that lightning is nothing more than electricity passing from one cloud to another just as an electric spark passes from one substance to another?

Franklin communicated these ideas to the Royal Society in London, suggesting at the same time that, if he was right, it would be possible to prevent a great deal of the harm done by lightning by fixing upright rods of iron near high

buildings so that the electricity might run down from the clouds into the earth without doing any harm. But this notion seemed so absurd, even to clever men, that they could not help laughing when his papers were read, and did not even think them worth printing. You will easily understand that after this Franklin was ashamed to speak of an experiment he meant to make by which he hoped to bring down electricity from the sky. So we find that he told no one but his son, whom he took with him upon this strange expedition.

Franklin's idea was that if he could send an iron rod up into the clouds to meet the lightning, it would become charged with the electricity, which he believed was there, and would send it down a thread attached to it, so that he might be able to feel it. He took, therefore, two light strips of cedar fastened crossways, upon which he stretched a silk handkerchief tied by the corners to the end of the cross, and to the top of this kite he fixed a sharp-pointed iron wire more than a foot long. He then put a tail and a string to his kite, and at the end of the string near his hand he tied some silk (which is a bad conductor), to prevent the electricity from escaping into his body. Between the string and the silk he tied a key, in which the electricity might be collected.

When his kite was ready he waited eagerly for a heavy thunderstorm, and, as soon as it came, he went out with his son to the commons near Philadelphia and let his kite fly. It mounted up among the dark clouds, but at first no electricity came down, for the string was too dry to conduct it. But by and by the heavy rain fell, the kite and string both became thoroughly wet, and the fibres of the string stood out as threads do when electricity passes along them. Directly Franklin saw this he knew that his experiment had

succeeded; he put his finger to the key and drew out a strong bright spark, and before long he had a rapid current of electricity passing from the key to his finger. The wise men of London might now laugh if they pleased, for the discovery was made; he had drawn lightning from the sky, and proved that it was electricity! Soon after this he made an apparatus in his own house for collecting electricity from the clouds, which rang a peal of bells when it was sufficiently charged for him to make experiments with it. He also invented lightning conductors, or iron rods placed near high buildings, to act as constant conductors between the clouds and the earth, and so prevent those sudden discharges called lightning.

Franklin had now earned a great name; he was made a Fellow of the Royal Society, and many honours were paid to him by all the countries of Europe. He made many other very valuable experiments, and was besides an active citizen and politician. He died in 1790, in his eighty-fifth year, after a life of hard labour and toil, for which, however, he was well repaid by success.

**Discovery of Animal Electricity by Galvani, and of Chemical or Voltaic Electricity by Volta, 1789-1800.**

—Only a few months before Franklin died, a new fact had been discovered about electricity, which would have given the old man great delight if he could have lived to see the results. This discovery was made by Galvani, Professor of Anatomy at Bologna, or perhaps we ought to say by Madame Galvani, for it was her observation which first led her husband to study the subject.

Aloysius Galvani was born at Bologna in 1737, and we know little of his early life except that, instead of becoming a monk as he first intended, he married a professor's daughter, and became the Lecturer on Anatomy in the University of Bologna. He had in his house an electrical

machine which he used for experiments, and one day in 1789, as Madame Galvani was skinning frogs for a soup, one of Galvani's assistants was working the machine near her. Just as the flow of electricity was going on rapidly, this young man happened to touch a nerve of the leg of a dead frog with a dissecting knife, and to his great surprise the leg began to move and struggle as if it were alive. Madame Galvani was so much struck by this that she told her husband of it directly he returned, and he repeated the experiment many times, and found that whenever the flow of electricity from the machine was brought near the nerve of the frog's leg it produced convulsions. He next tried whether lightning brought down upon the nerves of the leg would have the same effect, and the experiment succeeded perfectly.

Meanwhile another accident showed him that the convulsions could be produced without either lightning or an electrical machine. He had prepared the hind legs of several frogs and hung them by copper hooks upon an iron balcony outside his house. As they hung there the wind swayed them to and fro, so that the ends of the legs touched the iron of the balcony; and every time they did so he noticed that the legs were convulsed just as they had been by the electrical machine and the lightning. But this time he could not see that any electricity had come near them from outside, so he supposed that there must be an electric fluid in the leg itself, which passed round every time the two ends of the leg were joined by the metal. These discoveries of Galvani soon became spoken of far and wide under the name of *galvanism*, and the supposed fluid was called the *galvanic* fluid.

Among the celebrated men who were attracted by this new discovery was Alessandro Volta, Professor of Natural

Philosophy at the University of Pavia, who was born at Como in 1745, and was at this time a well-known naturalist. Not satisfied with merely reading about Galvani's experiments, Volta tried them himself, and he began to suspect that the electricity was not, as Galvani imagined, in the frog's leg, but was produced by the two metals, copper and iron, upon which the legs had been hung, and which were acted upon by the moisture in the flesh.

Then began a very famous controversy. Volta insisted that the electricity came from the *metals*, Galvani that it came from the *animal*. In each new experiment which Galvani brought forward to prove his point, Volta still showed that the electricity could be produced without the animal, until at last Galvani succeeded in finding a test which he thought must silence Volta for ever. He found that by laying bare a nerve of the leg of a frog, called the 'crural nerve,' and bringing the end of it to the outside of the muscles of the leg, he could produce the convulsions without *any metal at all*. But Volta was not so easily convinced; he still insisted that it was the different fluids and tissues being brought together which caused the electricity, and that there was not a current running through the animal. At this point, just when the truth would probably have been worked out, Galvani died (in 1798), leaving Volta in possession of the field; and for twenty-eight years no more was heard of animal electricity. We know now that both the professors were right. Volta was right in saying that the convulsions of the frog's legs on the balcony were produced by the contact of the two metals in connection with a fluid; while Galvani was right in saying that there is an electricity in animals which acts without any other help. In 1826 an Italian named Nobili repeated Galvani's experiment, and having then an instrument called

a *galvanometer* (see p. 365), by which the passage of the faintest electric current can be detected, he proved that such a current does exist in the frog, and it has since been found to be common to all animals.

Meanwhile, however, Volta had also made a very remarkable discovery, namely, that two different metals when joined together in contact with moisture, and separated from other substances, produce a current of electricity. This may easily be tried in its very simplest form. If you take a halfpenny and a half-crown and put one above your tongue and one below it, you will feel nothing remarkable

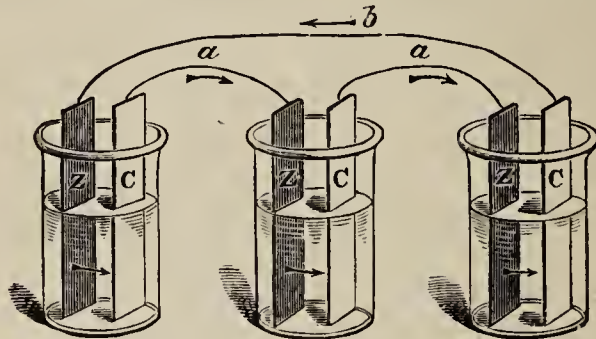

FIG. 46.

Volta's Crown of Cups (Fownes).

z, Zinc. c, Copper. a, a, b, Connecting wires. The arrows show the course of the positive currents.

so long as the two metals are kept separate, but directly you let them touch each other at the ends, a tingling sensation will pass through your tongue, proving to you that an electrical current is passing between the metals. If you put the half-crown under your lip, so that the halfpenny may remain outside your mouth, you may, perhaps, even see a slight flash when the two metals meet.

Volta found not only that it was necessary to have moisture between the two metals, but that some acid put in the water greatly increased the strength of the electricity. Fig. 46 shows the first electric battery which he made, and



which is the one now commonly used for simple experiments. In this battery each piece of zinc is joined to one of copper, and where the two are not united they are in the same cup, so that the liquid acts as a link to them. We know now what Volta did not know, that a chemical change is going on between the zinc and the acid water, which sets the action going, but we do not yet know exactly what the electricity itself is. The movement in Fig. 46 begins on the left-hand side at *z*. Here the current is set up by the action of the acid and water upon the zinc, and is passed on to the copper, *c*; then along the wire *a*, to the next *z*, and so on till it reaches the last cup, when it is carried by the wire *b* back to the first piece of zinc, and so the round is completed.

This battery is called the 'Crown of Cups,' but though it is so simple, it has not become as famous as the second battery made by Volta, which is still called the 'Voltaic Pile' (see Fig. 47). In this battery the metals are laid one above the other, and have small pieces of card or flannel between them which are wetted with salt and water. The battery ends with a plate of zinc at the bottom, and of copper at the top, and these are connected by the wire, *a a*. The action passes round this battery just as it did through the cups, and if the wire, *a a*, is cut in the centre and tipped with charcoal (which, being a bad conductor, causes the electricity to pass with difficulty), a bright spark will glow between the points as long as the battery is at work. Early

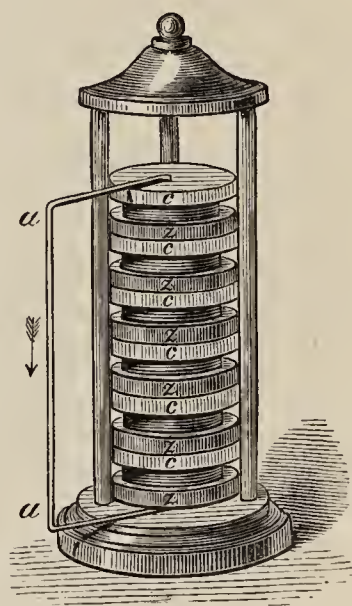

FIG. 47.

The Voltaic Pile (Fownes).

*z*, Zinc. *c*, Copper. *a, a*, Rod connecting the top layer of copper with the bottom layer of zinc.

in our own century Sir H. Davy succeeded with a battery of 3000 cells in producing a bright luminous arch between these points when tipped with carbon, and here we have the origin of our present electric light. Volta completed his Voltaic pile in 1800, just at the close of the century, and even from this slight sketch you may see what grand strides had been made in electricity during the past fifty years.

Franklin had proved the real action of electricity, had shown it to be the same as lightning, and had brought it down from the sky. Galvani had proved its existence in animals, and led the way to Volta's discoveries; and Volta had produced it in enormous quantities by two metals and acidulated water, so as to keep up a constant flow, which would travel any distance so long as the circuit was not broken. Here, you will see, was the first step towards the electric telegraph and the electric light, and though it was but a commencement, yet when we reap the benefits we must always remember the names of Franklin, Galvani, and Volta, as the great pioneers in the science of electricity.

---

*Chief Works consulted.*—'Lardner's Cyclopædia, Electricity, Magnetism, and Meteorology;' Encyclopædias 'Britannica' and 'Metropolitana,' art. 'Electricity;' Franklin's 'Experiments and Observations on Electricity,' 1749; Priestley, 'On Electricity,' 1785; Thomson's 'Hist. of Royal Society,' 1812; 'Life of Franklin,' by himself, 1833; Bennett's 'Text-Book of Physiology;' Fownes's 'Chemistry;' Wilkinson's 'Galvanism.'

## CHAPTER XXX.

## SCIENCE OF THE EIGHTEENTH CENTURY (CONTINUED).

Calculation of Musical Vibrations—Sauveur—Bernoulli, Euler, Lagrange—Nodes and Segments—Chladni—Plates, Bells, and Gongs—Sand Figures produced by Vibration.

**Calculation of Musical Vibrations—Sauveur, 1700.**

—After Newton had published his theory of sound, and some clearer ideas prevailed about the manner in which sound vibrations are conveyed to the ear, many mathematicians occupied themselves in working out the laws of those regular sound-vibrations which produce musical notes. Among the most celebrated of these were Sauveur (1653-1716), Daniel Bernoulli (1700-1782), Euler (1707-1783), and Lagrange, of whom we shall speak presently in connection with astronomy.

It will be remembered that Pythagoras by stretching a string on a sounding-board (p. 12) had obtained musical notes, whose intervals depended upon the lengths into which the string was divided. Galileo also had pointed out (p. 80), that in order to produce a musical note and not mere noise, the shocks given to the air must follow each other at regular intervals, and that the more rapidly the vibrations strike upon our ear, the higher is the note we hear; and two men, Noble and Pigot, had made in 1676 some very interesting experiments on the divisions of

stretched strings. But, curiously enough, it was a deaf man, or one who heard very imperfectly, who made the first accurate experiments as to the number of vibrations which produce any particular note.

Joseph Sauveur, the geometer, was born in 1653. He was dumb for seven years after his birth, and his speech as well as his hearing remained very imperfect during his whole life. Yet this man, who was a splendid mathematician, found his greatest pleasure in studying the mathematical theory of sound. Sauveur had remarked that a great confusion was created in music because there was no fixed note from which every one could agree to start, and in order to get this, it was necessary to fix upon some one note of a known number of vibrations. But how were the vibrations to be counted?

Sauveur devised the following method:—Musicians knew already that when two organ pipes of different lengths are sounded together, then, because the air-wave in the shorter one is driven back sooner than in the longer one, the puffs of sound will come more rapidly from the shorter pipe, just as the footfalls of a man who takes short steps will be more frequent than those of a man who strides. Now let us suppose two organ pipes, one, A, 8 feet, and the other, B, 9 feet long. A being one-ninth shorter than B, the puffs from that pipe will be one-ninth quicker, so that by the time A has made nine puffs it will have gained one whole step upon B, which will only have had time to make eight. Now all the time it is gaining, its puffs will come somewhere between those of B, but as soon as it has gained one whole stride the two pipes will sound simultaneously. This produces what musicians call ‘beats,’ or loud gusts of sound at regular intervals whenever the two pipes sound together, and it is clear that if you count how

many of these beats there are in a second, knowing that between each beat A must have given nine puffs, you have only to multiply the number of beats by nine, and that will give you the number of vibrations of the note sounded by that pipe.

Sauveur tried the experiment in this way, and found that when he sounded the low c in the 8-foot pipe it gave 122 vibrations in a second. He afterwards went on to apply this to stringed instruments, and made many remarkable experiments. Through his researches and those of Bernoulli, Euler, and Lagrange, it was proved that the sound given by a string when struck, depends upon four conditions, namely, its *length*, *thickness*, *weight*, and its *tension*, or the tightness with which it is stretched. When any one of these conditions is altered the string will give a different note, but when two strings are exactly alike in these four respects they will give the same note, because they will both make exactly the same number of vibrations to and fro in any given time. If one of them is only half as long as the other, it will make two vibrations while the longer string is making one, and then it will give a note an octave higher; all the other notes between these two can also be sounded by altering the relative lengths of the two strings.

It would be too long to work out here the laws respecting the intervals between different notes and the lengths of the strings producing them, but there are some curious and beautiful experiments with stretched strings which help us to have some idea of musical sound and its laws. If you stretch a string upon a sounding-board and then draw a violin bow across it, it will give a musical note. If you then touch the middle of the string quite lightly with a feather you will get the same note an octave higher, because, although the whole string is sounding, yet the feather keeps

the centre almost still, and the two divisions each vibrate twice as fast as the whole string did.

This is very simple ; but now place the feather so as to divide off one-third of the string, leaving two-thirds at the other end ; it would seem as if you ought to have two notes, one for the short string and one for the long one. But you will only get one note, and that will be one-fifth above the octave you had sounded just before. That is to say, you will get the same note as you would have had if the string ended at the feather and the other long piece did not sound at all. Yet you can easily convince yourself that the whole string is vibrating, and what is still more curious, that it has divided itself into *three short strings*, each one of which is vibrating as if it were quite separate

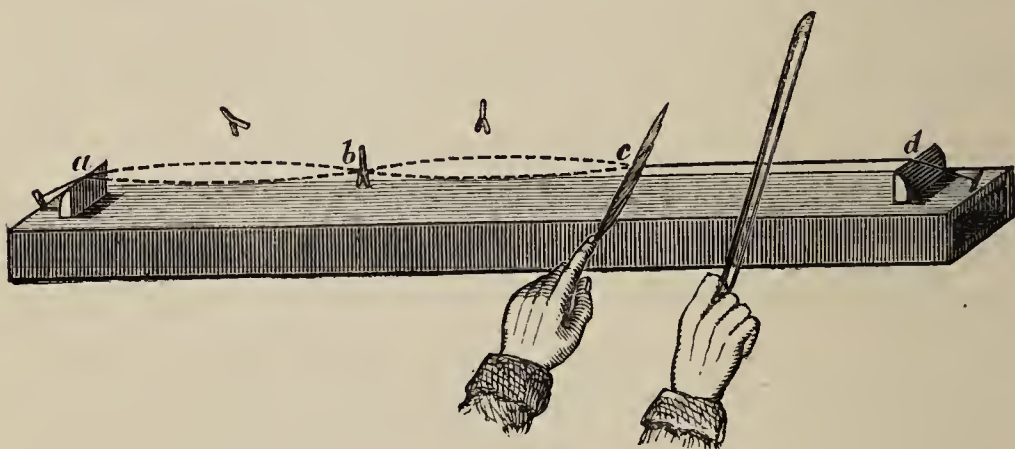

FIG. 48.

A stretched string damped at one-third of its length, *c*, and dividing with a natural node, or point of rest, between the remaining two-thirds at *b* (Tyndall).

To see this, take three small pieces of light paper bent so that they will ride upon the string. Then measure off your string into three equal parts and touch one of the dividing points (*c*, Fig. 48), with the feather ; place one of the paper riders upon the other dividing point *b*, and the other two, one half-way between *a* and *b*, the other between *b* and *c*. If you now draw the bow across the string between *c* and *d*.

two of the riders will fly off, showing that the long end of the string is vibrating, but the one at *b*, one-third from the end of the string, will remain, showing that at this point the string is comparatively quiet. The long part of the string has, in fact, *divided of its own accord into two parts a, b and b, c, each of them of the same length as the one you made with the feather.* Thus you have three short strings all vibrating at the same note, and, therefore, all sounding the same note.

But why should the long end of the string divide itself into two parts?

To answer this, take a long cord, and fastening one end of it to the wall, move your hand so as to make it rise up into one great wave-crest, *a* No. 1, Fig. 49. When this wave

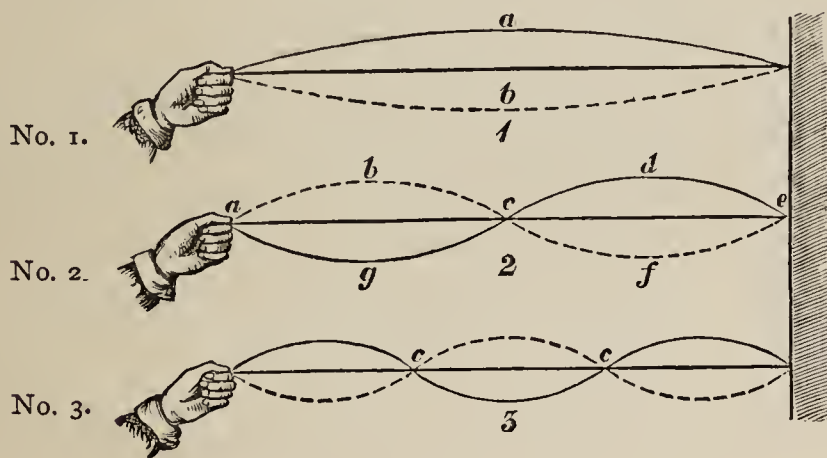

FIG. 49.

Vibrating cords showing how nodes are formed.

In No. 2 the line *a, b, c, f, e*, represents the shape of the cord during one half of the vibration, and the line *a, g, c, d, e*, the shape during the other half of the vibration.

reaches the wall it will be reflected, and will return to your hand, this time not as a crest, but in the shape of a valley or trough, *b*, and, as the rope is moving very rapidly, this will give the spindle-shaped appearance shown in the figure.

Next move your hand more quickly so as to make a crest and a trough, *a, b, c, f, e*, No. 2, between your hand

and the wall—this is called a whole wave. By the time this wave has reached the wall at *e*, the end of the rope in your hand will have begun to form the trough, *a, g, c*. Now notice what happens—the reflected wave from *e* travels back along *e, d, c*, and meets there the new direct wave, *a, g, c*, coming from your hand. Therefore, at the point *c*, these two movements will meet, and while the direct wave *a, g, c*, will be wanting to pull the string *up* to make its next crest *c, d, e*, the returning wave *e, d, c*, will be wanting to pull it *down* to make its next trough, *c, g, a*; therefore, at this point the string will remain almost at rest, forming what is called a *node* or knot.

Once past this point, each wave can go on its way, and the string will gradually assume the form *a, g, c, d, e*. In this way the vibration will continue in two divisions or segments with a *node* or point of comparative rest *c*, between them. It is not at all necessary that there should be only one point of rest in the string; by moving your hand more quickly you can make two nodes and three segments as in No. 3, and these may be increased almost indefinitely.

Now it is an action almost exactly the same as this which takes place in the stretched string of a musical instrument when it is made to vibrate. By holding the feather against the string at *b*, Fig. 48, and thus checking at this point the swing of the entire string you formed a *node*, and the vibration caused by the scraping of the violin bow instead of having its crest in the middle of the string, had it between *a* and *b*. This caused the trough to come between *b* and *c*, and the next crest between *c* and *d*. Then the reflected wave from *d* had the same effect as in your swinging rope, No. 3, Fig. 49, and in consequence the string was divided into three segments with two nodes, *b* and *c*. When once this vibration is set up, you may remove the feather altogether,



for the string will continue to vibrate in the same manner till it comes to rest.

All these facts about vibrating strings were worked out by Bernoulli, Euler, and Lagrange. Bernoulli also showed how the air vibrates in pipes, and why the note they produce depends upon the length of the pipe, and the sharpness with which the air is forced into it; but these experiments, though very interesting, are too long to enter upon here.

### **Chladni on the Musical Vibrations of Solid Bodies.**

—When it was once known that strings give out different notes according to their length, weight, thickness, and tension, and also that on any one string different notes are produced by the formation of nodes or points of rest, the foundation was laid for a full understanding of stringed instruments. But musical notes can be produced in a much simpler way than this. We know that by merely striking a glass or a piece of metal we can get a clear and beautiful note, and that these notes are different even in the same glass when it is held and struck in different places. For the explanation of these notes we must go to Chladni, a man who, on account of his wonderful researches, has been called the “Father of Modern *Acoustics*,” or the study of sound.

Ernst Chladni, the son of a professor of Law at Wittenberg in Saxony, was born in 1756, and having the misfortune to be the only son of an over-anxious father, his childhood was dreary in the extreme. He tells us that though he was kindly treated and had good teachers, yet he was never allowed to go out of the house alone, or to see any boys of his own age except at church. His father, indeed, never allowed him to go even into the garden unless the day was unusually fine, so that it is wonderful how he kept his health. He was not sent to school till he was fourteen years old, and then to so strict a master that he was but little better

off than at home. At last, when he was nineteen, he went to the university at Leipzig, where he had more liberty, but even then his great desire to turn his attention to medicine was checked, and his father insisted on his studying law. This severe discipline seems to have been very unnecessary as Ernst was a quiet, studious lad, and though at one time he tells us he was almost driven to run away from home, the mere thought of grieving his father was sufficient to detain him. He studied physics and natural history in secret, and being passionately fond of music, he took lessons on the piano while at Leipzig, but for all this he did not neglect his legal studies, and took his degree as Doctor of Law in 1782.

Just in this year, when his future career seemed fixed without any hope of change, his father died, and the moment he was free he gave up the law for ever and turned to science. As he had no fortune, this resolution cost him a long struggle with poverty, but his stepmother, who loved him as her own son, helped him out of her own income, and at last he earned enough by his writings and his musical instruments to live comfortably.

Chladni tells us that when his love of music led him to study harmony, he found so much in it that no one could explain, that he thought he might make some discoveries about musical sound. He had noticed that a piece of glass or metal gave out different notes when struck, according to the place in which he held it, but the reason for this he could not find given in any book.

About this time a celebrated physician, named Lichtenberg, had devised a way of making electrical figures by means of resinous powders scattered on glass. This suggested to Chladni that if musical notes were produced by longer or shorter vibrations with nodes or points of rest,

then, if he scattered sand over a piece of glass and struck the glass so that it gave out a note, the sand ought to be driven from those places which were vibrating, and to collect on the nodes where there was little or no movement.

Accordingly he took a round piece of brass belonging to a grinding-machine, and fastening it by its centre in a vice, scattered some sand over it, and drew a violin bow across the edge. As he had expected, the sand moved away from the bow, and from several other points at equal distances round the circle, and arranged itself

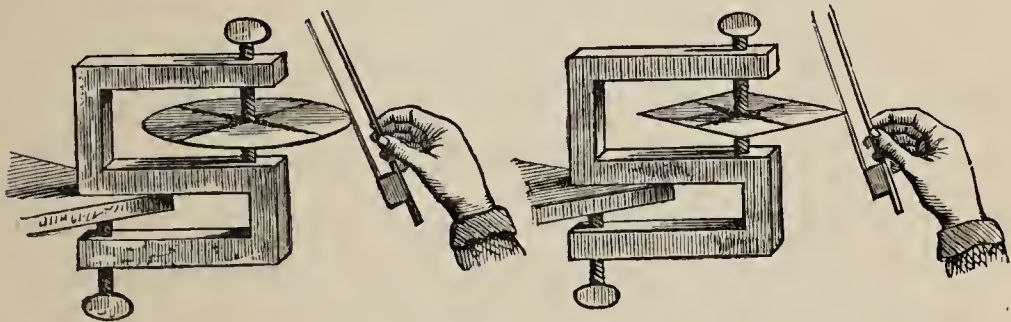

Fig. 50.

Plates of brass made to vibrate by a violin bow.

in the form of a star with several points ; at the same time the metal gave out a very sharp note, showing that the vibrations were very rapid. After many other experiments he proved that when the bow was drawn gently, so as to give out the lowest tone of the plate, the sand arranged itself in two lines crossing each other at the centre (see Fig. 50). This experiment is not difficult to try with a plate of metal or glass and a vice ; it will be the more sure to succeed if you place your finger on one of the nodes, that is  $\frac{1}{8}$ th of the circle away from the bow so as to be sure of getting the lowest note. But you may produce the same effect still more simply by taking a common finger-glass half full of water, and drawing a violin bow gently across the edge at *a*, Fig. 51. You will then find

that the water will be agitated in the form of four semi-

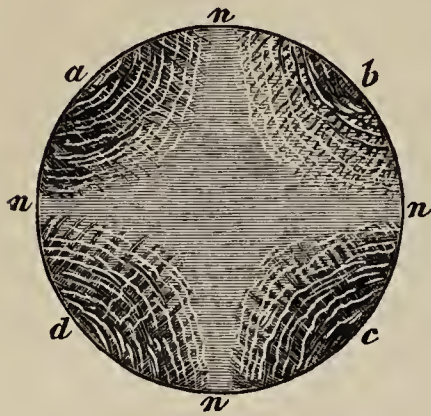

FIG. 51.

Water vibrating in glass bowl which is giving out a musical note.

was drawn will move most, and form the centre of a bulge, so will the point *c* opposite to it, making the dotted oval

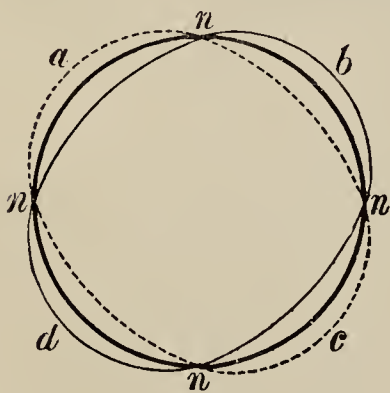

FIG. 52.

Changes of figure assumed by a glass when sounding.

by simply wetting your finger and passing it closely round the rim of the glass, for whenever the whole glass vibrates so as to give its lowest note, it forms two alternating ovals, and leaves the four points at rest. The sounds given out by bells, gongs, cymbals, glasses, etc., are all produced by this change of shape, which causes them to strike the air first one way and then the other, and so produce the series of condensations and rarefactions (see p. 168) which

circles, *a*, *b*, *c*, *d*, while from the centre to the four points, *n*, *n*, *n*, *n*, it will be still. The reason of this is, that when the glass is set vibrating, it assumes a slightly oval shape first in one direction  $\bigcirc$ , and then in the other  $\bigcirc$ , and these two movements produce a figure such as is shown much exaggerated by the fine lines in Fig. 52. The place *a*, across which your bow was drawn will move most, and form the centre of a bulge, so will the point *c* opposite to it, making the dotted oval *a*, *n*, *n*, *c*, *n*, *n*; immediately after, the other two points *b*, *d*, will bulge out in their turn, making an oval in the opposite direction; and so the water will alternately be pushed together and spread out at all these four places, but at *n*, *n*, *n*, *n*, it will not be disturbed, and so the nodes are formed.

You can even produce this figure

reach our ear. The number of sand-rays may be increased on round plates by placing the fingers on different points, and checking the vibrations, see Fig. 53. When Chladni had made many of these, and worked out their relation to the particular note sounded, he went on to experiment on



FIG. 53.

square plates, and produced the curious figures given in Fig. 54, and many others much more complicated. The first of these figures he got by fixing the plate by its centre and

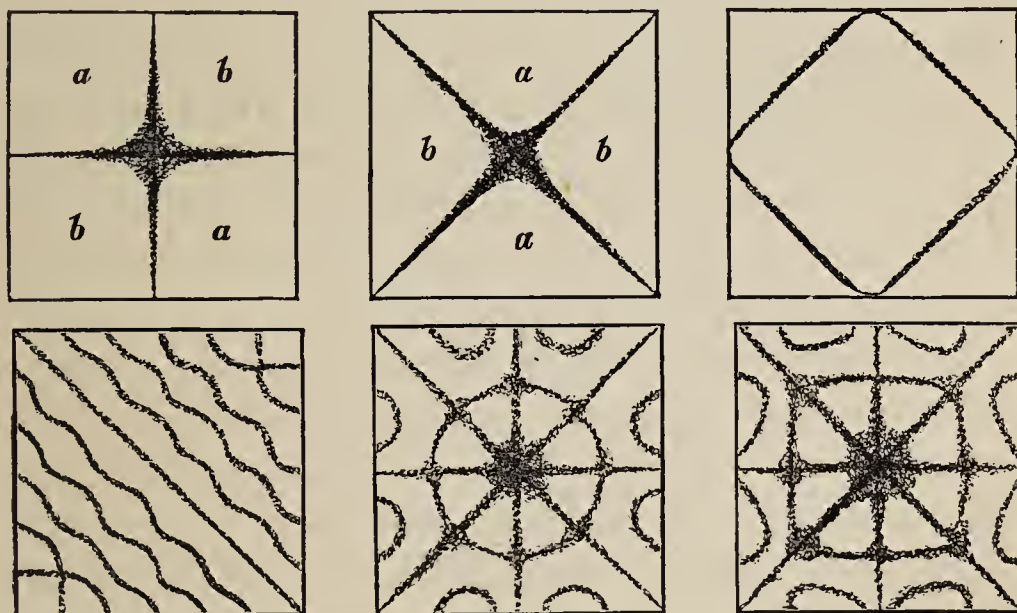

FIG. 54.

drawing the bow across one of the corners; the second by drawing it across the middle of one of the sides; and the more complicated figures below by placing the finger and thumb on various points so as to form artificial nodes.

The lines of sand on these plates are formed on the same

principle as the quiet lines of water in the glass, but their explanation is rather complicated. The first two are the most simple; in them the squares marked *a a* are always bending upwards when the other squares *b b* are bending downwards, and the lines between these four squares are therefore motionless, and form nodes. In our day Sir Charles Wheatstone has analysed all these vibrations, and shown mathematically why they assume the forms which Chladni produced.

Chladni did not only discover the way in which plates vibrate: he also worked out most carefully the whole theory of musical sound, and left behind him a 'Treatise on Acoustics,' which is still of very great value. He also invented two musical instruments, the euphone and the clavicylinder, which are, however, no longer in use. The manner of his death was somewhat singular. At an evening party held at the house of one of the professors of the Breslau University, he was speaking of sudden death as a happy thing when happening to a man whose work was done. At eleven o'clock he went home, and the next morning he was found dead in his chair; his watch, which he must have been in the act of winding, having fallen open at his feet. He had died of apoplexy.

As we shall not be able to return again to the subject of sound, it may be well to state here, that great advances have been made in it during the nineteenth century, especially by Professor Helmholtz, who has worked out the theory of musical sounds most completely, has also explained very fully the structure of the ear, and the manner in which the vibrations affect it.

---

*Chief Works consulted.*—Sauveur, 'Memoires; Acad. des Sciences,' 1701-1707; Fétis, 'Biog. des Musiciens;'; Helmholtz, 'Sensations of Tone;'; Tyndall, 'On Sound;'; Chladni, 'Die Akustik;'; Chladni, 'Entdeckungen über die Theorie des Klanges;'; Acad. des Sci. 1786.

## CHAPTER XXXI.

## SCIENCE OF THE EIGHTEENTH CENTURY (CONTINUED).

Bradley—Delisle—Lagrange—Laplace—Sir William Herschel—  
Binary Stars—Star-Clusters and Nebulæ—Motion of our Solar  
System through Space—Maskelyne—Schehallion Experiment—  
Summary of the Science of the Eighteenth Century.

**Astronomical Labours of Bradley and Delisle.**—And now, as we approach the end of the eighteenth century, we must take up once more the history of astronomy, which we have neglected since Newton died in 1727. Since that time many good astronomers had been occupied in making different observations, but the only two who need be mentioned were Bradley, the Astronomer-Royal (born 1692, died 1762), and Delisle (born 1688, died 1768).

Bradley explained two difficult astronomical problems; the first of these is called the ‘aberration of the fixed stars,’ which is an apparent movement of each fixed star in a small circle in the heavens, but which is really the combined effect of the yearly motion of our own earth, and of the time which light occupies in coming down from the stars to us. His second discovery is that of the *nutations*, or slight oscillation, of the earth’s axis. Both these observations are difficult to understand, but it is necessary to bear in mind that he made them, for they are very important in astronomy.

Delisle will interest you because he proposed a second

method of observing the transit of Venus, which is now used at stations where Halley's method (see p. 155) cannot be applied. Delisle's method consists in marking the time of commencement of the transit in one part of the world where it begins earliest, and at another station where it begins latest ; instead of measuring, as Halley did, the duration or length of time occupied by the whole transit as seen at each place. Halley's method requires the stations to be widely apart, east and west, and Delisle's, north and south.

These advances are all that need be mentioned during the first half of the eighteenth century, but during that time there had been born within a few years of each other three men, Lagrange, Laplace, and Herschel, who were to light up the close of the century with the most brilliant discoveries. The two first of these were Frenchmen, the last, though a German by birth, may almost be considered English as far as science is concerned ; for though he was born at Hanover in 1738, of German parents, still Sir William Herschel came over to England at the age of twenty-one, and all his discoveries were made here. It was our King George III. who gave him the pension which enabled him to devote himself to science, and he made England his home and country. His son, Sir John Herschel, who, like his father, was one of our greatest astronomers, was born in this country.

**Lagrange and Laplace.**—Louis de Lagrange was born at Turin in 1736. His father, who had been Treasurer of War, lost all his fortune when his son was quite a child, and Lagrange often said that it was partly owing to this mischance that he became a mathematician. His talent showed itself so early that before he was twenty he was appointed Professor of Mathematics in the Military College of Turin, where nearly all his pupils were older than himself. From



there he went to the Academy of Sciences at Berlin, and remained twenty years, during which time he worked out most of his celebrated problems. In 1787 he settled in Paris, where he died in 1813, at the age of seventy-seven.

Pierre Simon Laplace was the son of a farmer, and was born at Beaumont en-Auge, near Honfleur, in 1749. He, too, began work very early in life, for in 1769 the famous geometer D'Alembert was so struck with his talents that he procured for him the chair of Mathematics in the Military School of Paris, and from that time, for more than fifty years, Laplace devoted himself to the pursuit of science, never letting his active life as a politician interfere with his scientific studies. He died in 1827.

The work which was done both by Lagrange and Laplace in astronomy was purely mathematical, and dealing as it did with some of the most complicated movements of the heavenly bodies, it cannot be rightly understood by any but mathematicians. But some general idea may be formed of the problems they solved, and we will take these in the order of time, for they treated so much of the same questions, one taking up the subject where the other left it, that it is difficult to separate their work.

**Libration of the Moon accounted for by Lagrange, 1764-1780.**—Long before the time of Lagrange it had been known from observation that the moon always turns the same side of her globe towards our earth as she goes round it, so that we never see, and never can see, more than one side of her surface, so long as she has the same movement as at present. In 1764 the Académie des Sciences offered a prize for a complete explanation of this curious fact, and Lagrange was thus led to study the question, which he solved quite satisfactorily in 1780.

Many people find it very difficult to understand how the moon can be always turning round upon her own axis, as a top spins, and yet always keep the same side towards us ; therefore, it will be as well to make a simple experiment which explains it quite clearly. Take a round ball and stick a pin in one side of it, then turn the ball slowly round like a teetotum, and notice as it goes round that the pin points successively to each of the sides of the room one after the other ; then sew a piece of cotton to the side of the ball



FIG. 55.

Diagram showing why one side of the Moon is always turned towards the Earth.

M, Ball representing the moon. E, Point representing the centre of the earth. p, Pin to mark the side of the moon which is never turned towards the earth.

opposite the pin, and fasten the other end down to the table (as at E, Fig. 55). If you now roll the ball round the table, you will observe that the pin points to each side of the room in succession, as it did before, showing that it has been turning slowly once upon its own axis while going once round the point E, and that, for this reason, the

same side has been facing E all the time.

This is the case with the moon as she travels round our earth, and Lagrange proved mathematically that it must be so, as Newton had already suggested, if the moon's equator is not circular, but in the form of an ellipsoid, as in that case its longer axis would be acted on by the attraction of the earth so as to keep it always in the same direction. But Lagrange also showed that as the moon moves in an ellipse round the earth, and therefore goes at one time a little faster, and at another a little slower, while her rotation on her own axis does not vary, she does not keep always *exactly* the same face towards us, but we catch little glimpses farther round her globe, sometimes on one side and some-

times on the other. This balancing movement is called the *libration* of the moon.

**Laplace works out the Long Inequality of Jupiter and Saturn, 1774-1783.**—The next calculation about the planets was made by Laplace, and is more difficult to understand. You will remember that Newton showed that every planet attracts every other planet, and has some effect upon its path round the sun. Now it had been found, by comparing old astronomical tables with later ones, that these different attractions had altered some of the ellipses in which the planets move; and both Lagrange and a celebrated mathematician named Euler had tried to calculate these changes and find out whether the planets would ever come back into their old places. Laplace, however, carried the calculation farther than either Lagrange or Euler had done, and he showed that the whole machinery does work round in the course of a long period. Only two planets, Jupiter and Saturn, did not seem to follow this general law, but behaved in a very eccentric manner; for it appeared that during the seventeenth century Jupiter had been moving more quickly every year and Saturn more slowly. If this went on, it was clear that Jupiter would draw nearer to the sun, and at last fall into it, while Saturn would go farther off, and disappear entirely from our system, and this would upset the balance of our planets, and might lead eventually to our being all drawn into the sun.

This was a very serious question, and it was a grand step when Laplace answered it, and showed that there was nothing to fear, for that, odd as their movements appear, these two planets really obey the law of gravitation, and will return to their old places like the other planets after an immensely long period. He showed that their irregularity arises from the fact that Jupiter travels two-and-a-half times

round the sun while Saturn travels once, and on this account Jupiter is always overtaking Saturn, so that the two planets are often near together, or *in conjunction*, as it is called. When this happens, they pull each other so strongly that they are drawn each out of its proper path. If they always met in the same places, and so were pulled in exactly the same direction, they would never right themselves again; but as Jupiter does not quite make three rounds while Saturn makes one, their points of meeting vary a little each time, and this brings them round at last to their old positions. Laplace's calculation of this movement is called the *long inequality of Jupiter and Saturn*.

Laplace also discovered the reason why the moon goes on for a long time moving more and more quickly round our earth, and then gradually more and more slowly. This problem, which is too long to examine here, was the last which remained to complete the proof that Newton's theory of gravitation would account for all the movements of the heavenly bodies.

**Lagrange proves the Stability of the Orbits of the Planets, 1776.**—And now, in the year 1776, came Lagrange's great conclusion. He and Laplace had worked hand in hand, proving more and more at every step how beautifully all the heavenly bodies move in order, so that an equal balance is preserved between them all. At last Lagrange, taking up all the known facts and uniting them in one grand mathematical problem, proved that whatever might be the changes, and they are almost infinite, caused by all the attractions of the different planets on each other, yet in the course of long ages every part of the solar system remains stable. Each planet has its appointed road along which it travels, through many twists and turnings, but from which it cannot escape, for the grand force of

gravitation holds them all in one eternal round about their sun.

These are some of the problems solved by Lagrange and Laplace. You cannot expect to understand their full significance, nor must you imagine that these few pages contain more than a very small fraction of the work which these two mathematicians accomplished. Laplace made some beautiful calculations explaining the theory of the tides, and you will also often hear him mentioned as the author of the 'Nebular Hypothesis,'<sup>1</sup> by which he taught that our earth and all the planets were in the beginning formed by the condensation of gases and fluid matter. All this, which is too difficult to enter upon here, is discussed in his famous work, the '*Mécanique Céleste*,' published in 1799. But the main points to be remembered are that Lagrange and Laplace proved the regular order of the movements of the planets, and explained all those anomalies which had seemed to be out of harmony with Newton's theory of gravitation.

**Sir William Herschel constructs his own Telescopes, and discovers Uranus, 1781.**—William Herschel, who was born in 1738, was one of ten children. His father, who was an eminent musician, brought him up to follow his own profession, and when William came over to England with his regiment, he started in life as a teacher of music. The first three years in this country were years of hard struggle and privation, but at last he was appointed organist at Halifax in Yorkshire, and from there he went in 1766 to Bath, where he soon became known as a talented musician, playing in the Octagon Chapel and at concerts and parties with immense success, and attracting a large number of private pupils.

<sup>1</sup> This hypothesis had, however, been elaborated before the time of Laplace by the celebrated philosopher Kant.

It was at this time, in the midst of active work which kept him fully occupied all the day, that Herschel began those nightly observations which have made his name famous. His interest was at first excited by seeing the stars through a small telescope only two feet in length ; and his desire was so great to be able to penetrate farther into the starry depths, that he sent to London to order a large telescope. When the answer came, however, he found that the price of the instrument was quite beyond his means ; and so determined was he to carry out his project, that he set to work to construct a telescope with his own hands. The first one answered so well that he made several others, and at last succeeded in completing one forty feet long.

From that time he spent the greater part of every night in observing the stars, and on March 13, 1781, when he was examining some near the constellation Gemini, or the 'Twins,' he caught sight of one star more conspicuous than those around it. Struck by its size, he put a stronger magnifying power on to his telescope, and found to his surprise that this star became larger, while those round it remained as small as before. Now the fixed stars are so far off that no magnifying power makes any difference in their apparent size ; so Herschel began to suspect that this must be a body very much nearer to our earth than the stars which surrounded it. This led him to watch it, and he soon found that instead of being fixed it moved onwards steadily. He thought at first that he had discovered a comet, but it was not long before his wandering star was proved to be a new planet, moving round the sun outside Saturn. This planet is about half the size of Saturn, and takes more than eighty-four years to go once round the sun. It was first called the 'Georgian star,' after George III. ; then it was called 'Herschel,' after its discoverer ; and lastly

it received the name *Uranus*, which it still retains. It was through this discovery that Herschel became known, and George III. gave him a pension of 300 guineas a year, and a house near Windsor, in order that he might devote himself entirely to astronomy.

**Star-gauging and Discovery of Binary Stars, 1781-1802.**—One of the first tasks which Herschel undertook was to divide the stars into groups, according to their brightness, and to gauge the heavens by estimating the number of stars of each order of brightness, thus endeavouring to estimate the profundity of space. While he was thus *gauging*, or measuring the distance of the stars by the intensity of their light, his attention was arrested by some which appear single when seen through a small telescope, but which prove to be two stars when they are greatly magnified. A few of these double stars were known already when Herschel began to observe them, but he soon detected no less than 500 scattered about in different parts of the sky.

Now it had always been believed that the reason why these stars appeared close together was because one was almost directly behind the other a long way off, just as two posts standing one at some distance behind the other will appear to touch if they are nearly on a line with your eye. But this explanation did not satisfy Herschel, for he observed that many of the double stars, instead of merely passing to and fro in a straight line across each other, as they would appear to do in consequence of the movement of our earth in its orbit, had another peculiar curved motion, as if they were both moving round some point half-way between them. This movement was so slow that it was twenty-five years before he could be sure about it; but at the end of this time he was able to tell the Royal Society that these double or *binary* stars, as they are called, are not one behind the

other, but are actual pairs of stars moving round and round each other, as if they were connected by a rod suspended by its centre, and then set revolving!

To understand how great a discovery this was, it is necessary to bear in mind that Newton had only been able to prove that gravitation acts between the sun and the planets; but here was a reason for believing that even in the far-off stars, millions of miles away from our system, the same force is holding distant suns together, and keeping them in their orbits. This great discovery has been still more clearly proved by later investigations, and groups of two, three, and even more stars are now known, in which these bodies revolve round a common centre, held together by the force of gravitation.

**Herschel studies Star-clusters and Nebulæ, 1786.—**

The next discovery which Herschel made was quite as remarkable as that of the binary stars. As long ago as the time of Ptolemy (138 A.D.) five curious stars had been observed, which he called 'cloudy stars,' because they looked as if they were covered by a mist; and the number of these cloudy masses had been increased by different astronomers as time went on. When Herschel turned his attention to them he discovered so many that, in 1786, he published a catalogue of no less than a thousand, and added fifteen hundred more a few years later! Some of these bodies, such as the bright spot called the 'beehive,' in the constellation Cancer, were simply clusters of stars which could be seen distinctly through a telescope. In others the separate stars could not be seen even with the strongest magnifying power, but the group looked so much more distinct through a powerful telescope than through a feeble one, that it seemed most likely the stars were there, if only they could be distinguished. But a third set of cloudy



bodies did not appear in the least more separated, even with the largest telescopes, and these Herschel called *nebulæ* or clouds, because he believed they were made up of mere masses of matter which had not yet formed themselves into stars.

It was at this point that the grand thought forced itself upon his mind that in these *nebulæ* we might be looking at the actual beginning of new worlds : and that the creation of the different bodies of the universe was not begun and finished long ages ago, but is even now going on under our eyes. The *nebulæ* he believed to be composed of star-matter, out of which stars might be slowly forming, so as to be first seen scattered like minute points in some of the more hazy star-clusters, and then clearly visible, as in the 'bee-hive' in the constellation Cancer. In those days Herschel could get very few astronomers to believe in this idea, but you will see in the history of the nineteenth century how the discoveries of the spectroscope (see p. 339) have proved that the light of some of the *nebulæ* comes from incandescent gaseous matter ; so that it becomes extremely probable that Herschel was right, and that, in far distant space, star-mist is forming into stars, and creating new suns to illuminate the universe.

**The Motion of our Solar System through Space, 1783.**—The third and last theory which we can mention as coming from Sir William Herschel is that of the motion of our sun through space. In 1783 he showed from a study of the astronomical catalogues of past centuries that the stars do not stand in exactly the same places with regard to us as they did in ages gone by, and that, therefore, either we or they must be moving through space. Now, when *everything* around you appears to be moving backwards, it is most likely, to say the least, that it is you who are moving forwards,

and not that all other things are in motion ; therefore Herschel concluded that the reason of the apparent change in the place of the stars was the real movement of our sun and its planets among them.

But, if such were the case, then there ought to be one point straight in front of our path which would not appear to move ; for if you walk into a forest, you will observe that the trees on either side appear to spread farther and farther apart as you approach, but that those exactly in front of you will not seem to change their places. Now Sir W. Herschel found one point in the sky, in the constellation Hercules, where the greater number of the stars do not appear to move, while those to the right and the left seem to be gliding off each in their own direction. He therefore concluded that our sun is carrying the earth and the other planets straight towards this point in the constellation Hercules. The rate at which this movement goes on is not accurately known, but it must be very great, probably at least as much as 150,000,000 miles every year.

And here we must leave the discoveries of this great astronomer, although we have only glanced at them very superficially. The immense strides in astronomy made by Laplace, Lagrange, and Herschel cannot be understood in a moment ; and I wish you always to remember that you can only gather crumbs of knowledge from this book, which may, I hope, lead you to long and seek for more solid food. Before, however, we take leave of Sir W. Herschel, we must not forget to mention the faithful assistant who was so great a help to him in his labours.

When George III. gave Herschel his home and pension, the astronomer sent to Hanover for his sister Caroline, and she lived with him and received a small salary as his assistant. She shared his night-watches and mapped down the

stars, star-clusters, and nebulæ, as he came across them with his slowly-moving telescope; she helped to draw up his catalogues, to write his papers, and to make his calculations. In a word, she fulfilled one of the highest duties of a woman, in becoming the patient helpmate of a great and noble mind; and for this reason, although she never sought fame for herself, the name of Caroline Herschel will always be associated with the labours of our great astronomer. Sir William died in 1822, in his eighty-fourth year, leaving behind him a son, the late Sir John Herschel, who will be mentioned in the next chapter.

**Determination of the Density of the Earth by the Schehallion Experiment, 1774.**—After speaking of the wonders of the vast universe, and of suns so distant that we cannot even guess at the space which lies between them and us, we must now come back to our little planet and mention a remarkable experiment which was made in 1774 by Maskelyne, who was then Astronomer-Royal of England. This was the finding out of the weight of the earth compared to its size, or, in other words, the *density of the earth*.

If our globe were made of one material, it would be easy to weigh a small piece and multiply that by the size, which we know pretty accurately, and so to get at the weight of the whole. But as the rocks of the earth's crust differ very much in weight, and we do not know what the middle of the globe is made of, this plan is not possible. We know, however, that every atom of matter has the power of attraction, so that if we could find out how much attraction our earth possesses, by comparing it with the attraction of some other body which we can weigh, then we could arrive at the weight of the earth.

Now Newton, in his 'Principia,' had pointed out that a plumb-line, that is, a piece of string with a weight of lead at

the end of it, will not point straight to the centre of the earth when it is held near a mountain, because the mountain attracts the lead and draws it slightly towards itself. Therefore, if the size and weight of the mountain were known, and it were also known how great its pull is compared to the pull of the whole earth, this would enable a

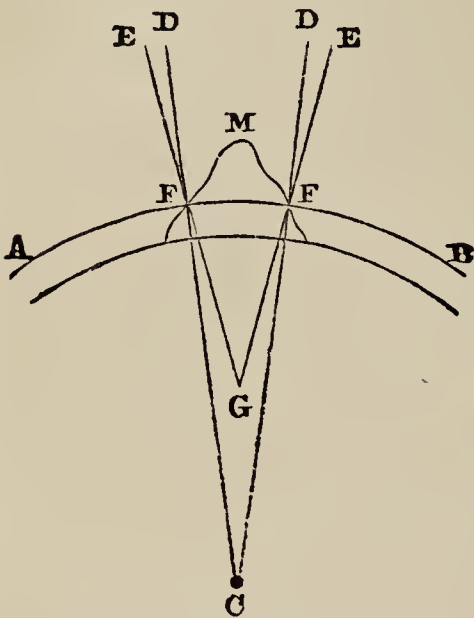

FIG. 56.

Schehallion Experiment for estimating the Density of the Earth (Herschel).

A B, Surface of the earth. D, C, D, Angle formed by the two plumb-lines pointing to the centre of the earth. E, G, E, Angle formed by the two plumb-lines when drawn aside by the mountain M.

mathematician to calculate the weight of our entire globe.

A man named Bouguer was the first to make this experiment near a high mountain in Peru in 1738, but he succeeded very imperfectly, and in 1772 Maskelyne proposed to the Royal Society to repeat the observation.

Accordingly, he went in 1774, to a very high mountain called Schehallion, near Loch Tay, in Perthshire, and there he measured the inclination or slope of the plumb-line on each side of the mountain. You will remember that, according to the theory of

gravitation, the lead at the end of the line would point straight to the centre of the earth c if the mountain did not disturb it;<sup>1</sup> and if the plumb-line is taken to two places a certain distance apart and its inclination measured by means of one of the stars overhead, it is easy to find out

<sup>1</sup> This is not strictly true, on account of bulge at the equator and flattening of the poles; but the discrepancy is of no importance to the argument.

exactly how much the lines D F will slope towards each other when no mountain is between them. This measurement being known, Maskelyne then made two observations, one on each side of Schehallion, and found that in this case the inclination, instead of being from D to F on each side, was from E to F, because the mountain drew the lead towards itself on either side. So the deflection E F D, through which the plumb-line was drawn from the perpendicular, showed the difference between the pull of the whole earth and the pull of the mountain.

Then Dr. Hutton, the celebrated geologist, set to work to find out the size and weight of Schehallion. This he did by surveying it and measuring it in every direction, and then taking pieces of the different rocks it contained and weighing them carefully. When this was done, it was found that the mountain pulled half as strongly in comparison to its size as the earth did for its size. This showed that the materials in the mountain were half as heavy as the average of those in the earth generally, and as they were also about  $2\frac{1}{2}$  times as heavy, bulk for bulk, as water, it was proved that the whole globe is about *five times* heavier than it would be if it was made entirely of that fluid.

This calculation must be very near the truth, for the chemist Cavendish obtained nearly the same result from quite a different experiment made with suspended balls. This, which is called the 'Cavendish experiment,' is too difficult to explain here. In our own times, Francis Baily, Sir Henry James, Sir Edward Sabine, and others, have repeated these observations, and found them to be correct.

#### **Summary of the Science of the Eighteenth Century.**

—This sketch of the advance of astronomy brings us to the end of the science of the eighteenth century; for although the greater number of the eminent scientific men of our day

were born before the year 1800, yet their works belong chiefly to the nineteenth century. Before going farther, therefore, we must now look back and see how far science has travelled since our summary of the seventeenth century.

**Biology**, or the science of life, had made great progress. It had been enriched by the study of *organic chemistry*, founded by Boerhaave, by which we learn the elements of which living bodies are composed; by a more complete knowledge of *anatomy*, or the structure of the body in all its most minute parts, as Haller studied and represented them in his anatomical works; and by a knowledge of *comparative anatomy*, as taught by John Hunter, or the comparison of each organ as it appears in different beings, from the lowest animal up to man. But even now the chief point remains to be mentioned, for all these are of little use without the study of *physiology*, or the science of living beings, in which we must not only learn the great facts of the working of our own bodies and those of animals, but must take into account the strange freaks of nature taught us by the experiments of Bonnet and Spallanzani. In the history of the nineteenth century we shall have to consider some of these facts, and see how Cuvier, Lamarck, and Darwin have carried out the study of physiology to great results in our own day. But we have still more to include under Biology. After learning the nature of living beings, we must have some order of arrangement by which we can distinguish them. Here we come to the work of Linnæus, one of the grandest men of the eighteenth century. While Buffon was popularising natural history, we find the great Swede patiently working out all the minute characters and general features of animals and plants, and reducing the whole kingdom of life into such beautiful order, that after

his time it could be studied accurately and usefully by all who cared to take time and trouble.

Thus, even without mentioning the science of medicine, which had grown far beyond our power of following it up ; or the wonderful work with the microscope, which had increased rapidly since the days of Grew and Malpighi, biology grew during the eighteenth century into a group of sciences, the works upon which would fill a library, and each branch of which requires the study of a lifetime to master it.

**Geology.**—Side by side with biology arose, about this time, the modest and almost unnoticed *science of the earth*, then generally called physical geography, but now known as Geology. This was a small seed sown in the eighteenth century, to grow into a large tree only in our time ; yet it was a great step when Scilla insisted that fossils were the remains of living beings, and that the rocks containing them were formed gradually under lakes or seas. And when Werner taught men to study the earth's crust, and Hutton forced them to see that Nature is, and has always been, building up our present world out of the ruins of the past, the foundations were laid for the real study of the earth and its formation. Meanwhile William Smith toiled over England, mapping out the position of each rock as he saw it, and thus he led the way to a long series of careful observations, by which the whole geology of England has been worked out.

**Chemistry.**—But the science which before all stands forth in the eighteenth century is *chemistry* ; for here the discovery of the different gases led to certainty where all had been guess-work before, showing the actual chemical changes which are taking place on all sides in the world around us, and teaching men to weigh and test invisible substances, and not to rest satisfied with their knowledge of any substance

till they have traced it home to its first and simplest elements. We need not recapitulate here the different discoveries of Scheele, Bergmann, Black, Cavendish, Priestley, and Lavoisier. You will remember how they all helped to overthrow the theory of Phlogiston, and to prove that combustion and respiration are merely chemical changes taking place between different substances and the oxygen of our atmosphere ; and this truth is the starting-point of modern chemistry.

**Physics.**—In physics the three subjects in which we have noticed advances are those of *sound*, *heat*, and *electricity*. In the first of these the interest is chiefly theoretical, and we learn how the melodies and harmonies which are so pleasing to our ears are the result of vibrations acting under fixed laws, so that we can calculate with the greatest exactness what are the movements of any particular body giving out a musical sound, and can even convert the sound, as it were, into a visible figure in which we can read the history of the note's production. The discoveries in the other two subjects, heat and electricity, are of great practical interest, and have caused greater changes throughout the world than any previous discoveries. When Black proved the amount of heat which is lying hid in water and in steam, and when Watt applied it to the steam-engine, a giant power was born into the world which has worked marvels. Visit any of the little towns all over England and see the machines of all kinds moved by the simple power of steam ; then go to the great manufacturing towns and see the huge engines doing the work of thousands of horses, with no other help than that of a man feeding the furnace with coals. Look at any one of your own clothes, at the iron-work in all parts of your house, from the rough heavy iron of fireplaces and fenders to the delicate steel spring which moves the hands of your watch ; look at the planks on your



floors, and the carpets which cover them ! All these have been woven, and forged, tempered, sawn, and worked by steam machinery. Then think of the way in which people are carried from one place to another of the world ; so that in one month a man may be in India, and the next in London ; while food, clothing, and goods of all kinds are spread over different countries in a few weeks wherever they are most wanted. And then remember that all this has sprung out of the *latent heat* of steam, and its application by Watt to the steam-engine.

The next discovery is perhaps even more wonderful. Franklin tries experiments upon the peculiar power known by the name of *electricity*, and he suspects that it is everywhere and in everything. He proves its transmission from one body to another, and finds out many of its properties. In spite of the derision of his friends, he seeks to bring it down from the sky, and succeeds in making a prisoner of the lightning and working with it in his own laboratory. Galvani next finds this wonderful power hidden in the nerves of a frog ; while Volta crowns the whole by showing that electricity can be produced by two metals placed in a little acid and water, and that this can be carried along a wire of any length which touches the battery at both its ends. Here lies hid the germ of the electric telegraph ; but the grand secret of carrying messages from one end of the world to another in a few moments was not to come yet. That remained for the nineteenth century to accomplish.

**Astronomy.**—Lastly we come to astronomy, and to some of the most tremendous problems in the working of our universe. Here we find Lagrange proving that the system of our sun and planets is self-regulating, so that in spite of all its infinite changes there is no real irregularity or changeableness in its machinery, but all moves in one

---

perfect and constant round. Laplace shows the reason of those irregularities which seemed to contradict Newton's law of gravitation, and proves that they are all explained by that law, thus completing the work of the great astronomer. Then Herschel takes up the story, and after discovering a new planet, he studies the cloudy nebulæ, and points out the probable formation of new suns going on now in far-distant regions ; he pictures our own sun rushing through space at the rate of 150,000,000 miles a year, carrying with it our earth and all the other planets ; and above all he traces the law of gravitation into the distant star-world, and shows it there holding suns together and causing them to revolve round each other. And so, out into space as far as the mind can reach, we find everlasting order reigning throughout the visible universe.

---

*List of Works consulted.*—Herschel's 'Astronomy ;' Arago, 'Vie et travaux de Herschel,' 1843 ; Proctor's 'Essays on Astronomy,' 'The Universe,' 'Other Worlds than ours ;' Grant's 'History of Physical Astronomy ;' Arago, 'Eloge of Laplace ;' Airy's 'Astronomy ;' 'Encyclopædia Britannica'—'Astronomy ;' 'Orbs of Heaven,' Mitchell.

SCIENCE OF THE  
NINETEENTH CENTURY

*In this List are mentioned only the chief of those Men of Science of the Nineteenth Century whose discoveries are treated of in the following pages.*

Those whose death is left blank were living in 1883.

	A. D.		A. D.
Piazzi . . . . .	1746-1826	Wollaston . . . . .	1766-1828
Olbers . . . . .	1758-1840	Biot . . . . .	1774-1862
Encke . . . . .	1791-1865	Berzelius . . . . .	1779-1848
Gauss . . . . .	1777-1855	Dalton . . . . .	1767-1844
Sir J. Herschel . . . . .	1792-1871	Davy . . . . .	1778-1829
Airy . . . . .	1801-—	Faraday . . . . .	1791-1867
Adams . . . . .	1818-—	Liebig . . . . .	1803-1873
Leverrier . . . . .	1811-1877	Graham . . . . .	1805-1869
Galle . . . . .	1812-—	Andrews . . . . .	1813-—
Schwabe . . . . .	1788-1875	Avogadro . . . . .	1731-1813
Watson . . . . .	1838-1880	Wöhler . . . . .	1800-1882
Asaph Hall . . . . .	1829-—		
Young . . . . .	1773-1829	Humboldt . . . . .	1767-1835
Malus . . . . .	1775-1812	Buckland . . . . .	1784-1856
Fresnel . . . . .	1788-1827	Lyell . . . . .	1797-1875
Arago . . . . .	1786-1853	Murchison . . . . .	1792-1871
Seebeck . . . . .	1770-1831	Sedgwick . . . . .	1787-1873
Oersted . . . . .	1777-1851	Agassiz . . . . .	1807-1873
Ampère . . . . .	1779-1864	Boucher de Perthes . . . . .	1788-1868
Brewster . . . . .	1784-1868	Hooker, Sir W. . . . .	1785-1865
Sabine . . . . .	1788-1883	Sprengel . . . . .	1750-1816
Fraunhofer . . . . .	1787-1826	A. de Jussieu . . . . .	1748-1836
Herapath . . . . .	1796-1868	R. Brown . . . . .	1773-1858
Clausius . . . . .	1822-—	De Candolle . . . . .	1778-1841
Wheatstone . . . . .	1802-1875	Lindley . . . . .	1799-1865
Bunsen . . . . .	1811-—	Endlicher . . . . .	1804-1849
Fizeau . . . . .	1819-—	Von Mohl . . . . .	1805-1872
Foucault . . . . .	1819-1868		
Rumford . . . . .	1753-1814	Lamarck . . . . .	1744-1829
Mayer . . . . .	1814-1878	Goethe . . . . .	1749-1833
Joule . . . . .	1818-—	Cuvier . . . . .	1769-1832
Thomson, Sir W. . . . .	1824-—	G. St. Hilaire . . . . .	1772-1844
Helmholtz . . . . .	1821-—	Von Baer . . . . .	1792-1876
Weber . . . . .	1804-—	Wallace . . . . .	1822-—
Clerk-Maxwell . . . . .	1831-1879	Darwin . . . . .	1809-1882
Kirchhoff . . . . .	1824-—	Herbert Spencer . . . . .	1820-—
Tyndall . . . . .	1820-—	Huxley . . . . .	1825-—
Huggins . . . . .	1824-—	Owen . . . . .	1804-—
Miller . . . . .	1817-1870	Balfour . . . . .	1851-1882
Crookes . . . . .	1832-—		

## CHAPTER XXXII.

## SCIENCE OF THE NINETEENTH CENTURY.

Difficulties of Contemporary History—Olbers—Asteroids—Encke's Comet—Biela's Comet—Adams—Leverrier—Discovery of Neptune—Sir John Herschel—Comets and Meteor-Systems.

WE have now arrived fairly at the beginning of our own century, and shall have to speak of events which happened as it were but yesterday, and of men whom our grandfathers, or even perhaps our fathers, have seen and known. How are we to find our way through the mass of discoveries which have been made in every science during the last seventy years, or to make our choice among the number of famous men whose names we meet with every day? We must begin at once by recognising that it is impossible to mention all, even of the leading points, of the science of our time, and then we may try to learn a few of them, if we do so with a clear understanding that we are leaving important gaps unfilled.

There are two special difficulties which we must encounter in the history of this century; first, we cannot avoid mentioning the work of some living men, while at the same time we omit others who are equally eminent; and secondly, we must speak of many subjects which are still, as it were, on their trial, and which will not be finally settled till they can be judged dispassionately by future generations.

I have tried, however, to follow as far as possible the plan I adopted in the earlier centuries, of mentioning only a few great men whose work you can understand and follow ; and stating on doubtful subjects what is the opinion of those who are best able to judge from the evidence. Therefore you must constantly bear in mind that this last portion of the book cannot be said to contain a history of the science of the nineteenth century, but only an account of a few of the leading discoveries and theories of our times and of the men who made them.

**Advance in Astronomy.**—The science of Astronomy, in particular, has spread far beyond our power to follow it. We have seen that astronomers, up to the end of the eighteenth century, were always striving to work out the laws which govern the movements of the heavenly bodies. The key to this problem was found by Newton, and the work was so far completed by Laplace and Lagrange as to show that even those planets which seem to have the most irregular orbits are really governed by the force of gravitation. From that time astronomy became an *exact* science, and men had only to make their calculations with perfect accuracy in order to be able to foretell what was going to happen ; or, if they failed, then they knew there must be some other unknown heavenly body (such as Neptune, p. 302) causing the irregularity. Therefore the science of astronomy in our century has been chiefly occupied in recording, with ever increasing accuracy, the positions of the heavenly bodies—sun, moon, planets, and stars ; and it is from the discussion of these observations that Leverrier has been enabled to produce his theories of the planets, and that Hansen, Pontécoulant, Delaunay, and Adams have perfected the theory of the complicated motion of the moon. And side by side with this has grown up a new study, namely, that

of the nature of the sun, planets, stars, comets, meteors, etc., telling us what they are like in themselves, whether they have an atmosphere like our own, and of what materials they are made. This study has been carried on partly by powerful telescopes, but chiefly by the wonderful method called *spectrum analysis*, of which we shall speak presently. Meanwhile we must first begin by naming a few new bodies lately observed in the heavens.

**Discovery of the Asteroids and Minor Planets between Mars and Jupiter, 1801-1807.**—Not long after the discovery of Uranus, a well-known astronomer named Bode pointed out that the distances of the planets from the sun seemed to follow a remarkable arithmetical law. The only exception to this law was between Jupiter and Mars; and here the gap was twice as large as it ought to be according to the calculation. Therefore astronomers suspected (as indeed Kepler had suggested more than 200 years before) that there must be a planet between these two which had not yet been seen; and in the year 1800, at a meeting at Lilienthal, in Saxony, they agreed to search diligently for this supposed missing body.

Signor Piazzi, the Astronomer of the Observatory at Palermo, in Sicily, was one of these planet-seekers, and on the first night of the year 1801 he caught sight of a small star in the constellation Taurus, which had not yet been noticed in any catalogue. The next night he looked for it again, and found that it had moved its position. He did this for twelve nights, and the movement seemed to show that it must be the planet he was seeking. Just at this point, however, he was taken ill, and although he had told other astronomers of what he had seen, no one could find the planet again. Months passed, and people began to doubt whether he had not made a mistake; but at last a young

German astronomer, named Gauss, set to work to calculate, from the facts which Piazzi had given, whereabouts in the heavens the planet ought then to be, and turning his telescope to the point, there he found it! This planet was called Ceres; it was very small compared to the other planets, but the astronomers were satisfied at having filled up the supposed gap.

Before two years had passed away, however, in the year 1802, Dr. Olbers of Bremen announced that he had found another little planet near Ceres, which he called Pallas, and in 1804 a third was found by another astronomer named Harding, who called it Juno. It seemed very strange that so many bodies should be moving round the sun at nearly the same distance from it, and Dr. Olbers suggested that they might perhaps be parts of one large planet which had broken up into fragments. If this was so, he expected to find more, and truly enough, in 1807 a fourth was discovered, which he called Vesta. In 1845 and 1847 two more were added to the number. Since then some have been found every year; in May 1883 the number of these small planets, or *asteroids* as they are called, moving round the sun between Mars and Jupiter, had reached to 232, and new ones are always being discovered. Ceres, the largest of these, only measures about 196 miles across, and when it comes nearest to the earth does not look larger than a star of the eighth magnitude. Whether they are really fragments of a planet is not proved; and we have still a great deal to learn about them.

**Encke's Comet, 1819.**—The next bodies of interest which were discovered were two returning comets, each of them remarkable for different reasons. The first of these was observed in 1819, through the telescope at Marseilles, by a Frenchman named Pons. It was very small, and is



mainly of importance because, after Professor Encke of Berlin had calculated that it returned regularly every three years and a quarter, he found that it arrived two hours and a quarter earlier each time. Why it should come earlier is a question which is still very perplexing to astronomers, though several explanations have been suggested. In order to find out how fast this comet moved, Encke was obliged to calculate very accurately how much the different planets attract it; and this led him to discover that the mass of Jupiter is greater than the earlier astronomers had supposed, while that of Mercury is much less.

**Biela's Comet, 1826.**—In 1826 another remarkable comet was observed by an Austrian officer named Biela, and on that account called 'Biela's comet.' M. Clausen, a German astronomer, computed that it revolved in an elliptic orbit in a period of six years and eight months, and it was then shown to be the same comet which had been observed in 1772, 1805, and 1818. This comet has had a very curious history. In the year 1832 great alarm was excited because the astronomers had calculated that it would cross the orbit of our earth on October 29. People who did not understand the question thought this meant that it would run into us and perhaps destroy our earth; and many even sold their houses and land because they thought the end of the world was at hand. The people in Paris especially were so frightened about it that the Academy of Sciences thought it advisable to ask Arago, the French astronomer, to quiet their fears, and he wrote a popular essay, showing that though the comet crossed the path of our earth, yet on that day we should be fifty-five millions of miles away from the spot.

But it was in 1845 that Biela's comet proved most interesting. On November 26 in that year it came at the

time it was expected, and was seen each night afterwards as usual till January 12. On that night, however, when Lieutenant Maury looked at it from the observatory at Washington, in the United States, he saw, not one comet, but *two distinct and separate comets moving along together*. This seemed so strange that it would scarcely have been believed if several astronomers had not watched the comet for more than a month, and satisfied themselves that it had really split up into two parts, each part being a perfect comet, with a bright head and a glowing tail! These two comets returned in 1852, still keeping each other company at the same distance apart as in 1846, but since then they have never been seen again. Many other comets have been discovered besides these, and it is probable that many thousands or even millions must be wandering through space, but of these we cannot speak here.

**Adams and Leverrier determine the Position of an Unknown Planet by its Influence on the Orbit of Uranus, 1843-1846.**—The next discovery which we must consider is one of the most remarkable in the history of astronomy, because it was not made with the telescope, but was worked out independently by two men entirely by means of Newton's theory of gravitation. You will remember that in 1781 Sir William Herschel discovered the planet Uranus moving outside all the other planets (see p. 282). Now, many astronomers had noticed this body in earlier ages, and supposing it to be a star, had marked its position from time to time in the heavens, and from these observations it was now possible to calculate its path round the sun. When this was done it was found, however, that the planet did not move as it ought to do according to the theory of gravitation. The pull of the sun and the known planets did not account for its orbit, for it roamed farther out into

space than it should do if they were the only bodies which attracted it. Either, therefore, the early astronomers had marked the position of the planet wrongly, or some unknown and unseen body must be pulling it out of its course. This last seemed the most likely explanation, but no such planet could be seen, and the problem remained unsolved.

It was at this point that a young student of St. John's College, Cambridge, named John Couch Adams, then only twenty-three years of age, made a memorandum in his notebook to work out the movements of Uranus, and see if by this means he could discover whether there was another planet farther away from the sun. As soon as he had taken his degree as Senior Wrangler in 1843, he set to work to carry out his intention, and two years afterwards, in October 1845, he sent a paper to Mr. Airy, the Astronomer-Royal at Greenwich, stating in what part of the heavens astronomers ought to look for the unknown planet which would explain the capricious movements of Uranus.

It is not easy for any but mathematicians to understand what a wonderful thing it was to calculate accurately, in this way, where a planet would be found which had never been seen. When Pallas was discovered between Mars and Jupiter, Piazzi saw it through the telescope for some days, and it was only found again by following out the movement which he had recorded. But in Adams's case nothing had ever been seen, and the only reason for suspecting anything to be there, was that astronomers could not make their very difficult calculations of the attraction of the different planets come out right. Adams, therefore, had first to calculate all the attractions of the sun and the planets, in their different positions, and then to find out how they would affect Uranus in his path; and wherever the planet did not follow their

pulling he had to calculate where another body must be to draw it away from them. This he accomplished, and it is very remarkable that the great French astronomer Leverrier also worked out the same problem, without having heard that Adams had done it.

In the year 1838 Leverrier had begun a long series of calculations, which were only completed in 1874 (see p. 461), to find out the varying attractions, and by that means the size and weight, of the different planets, and while he was at work at this he became convinced that there must be some unseen body pulling at Uranus. Now it so happened that just at the time when Adams and Leverrier began to feel after this supposed planet, Uranus had lately been very much disturbed, and so they knew that he must have approached near to the disturbing cause, and this showed them in which part of the heavens the attracting planet ought to be.

Leverrier published his calculations in the *Journal of the Académie des Sciences* at Paris in November 1845 and June 1846, and when the Astronomer-Royal read the papers he was astonished to find that the French astronomer had fixed the place of the unknown planet within one degree of the spot which Adams had named. This led him to suggest that a search should be made for it, and Professor Challis of Cambridge actually observed and recorded its place on August 4 and 12, 1846, but having no chart of that part of the heavens, was not able to identify it. Meanwhile Leverrier published another paper on August 31, 1846, stating still more accurately where the planet ought to be found. This paper he sent to his friend M. Galle, of the Berlin Observatory, on September 23, 1846, asking him to look in that part of the sky which he pointed out. M. Galle did so, and *on that same night, by following the instructions of the*

*two astronomers, he found the unknown planet, which he identified from a chart in his possession.*

So true is the law of gravitation that two men sitting at home in their studies were enabled, from slight irregularities in the motion of Uranus, to predict the existence and place of a disturbing body, rolling on through space! This new planet is called Neptune, and is a little larger than Uranus; it has certainly one moon, discovered by Mr. Lassell, and Herr Struve thinks he has seen a second.

**Sir John Herschel's work in Astronomy.**—While these different discoveries were being made in the observatories of Europe, Sir John Herschel was at the Cape, sweeping the heavens with his telescope for double stars and nebulae, and measuring their brilliancy. Born at Slough, close to his father's observatory, in 1792, the young John Herschel spent his early life with his father and aunt, and saw them always busy night and day studying the heavens. In 1813 he was Senior Wrangler at Cambridge, and after that he turned his attention to double stars, and in 1818 completed a list of no less than 2000 of these wonderful double and sometimes treble suns which revolve round each other. When he had completed the survey of the whole of our northern skies, he went in 1833 to the Cape of Good Hope, taking with him a large telescope, for which he built an observatory, and there he spent four years gauging the stars of the southern hemisphere, and classing them according to their brilliancy, as his father had classed those of the northern hemisphere. He was thus the first astronomer who swept his telescope over the whole of the heavens which are visible from our planet, and who saw with his own eyes every star, planet, and nebula, then visible in the sky. Among the remarkable appearances which he examined were those cloudy

masses of light called the *Magellanic Clouds*, which are a portion of the Milky Way of the southern hemisphere, and he found them to be made up of stars, star-clusters, and nebulæ, mingled together in wonderful complexity.

When he returned to England in 1838, you can imagine what a wonderful picture he must have had in his mind of the whole universe, as far as we can see it. It was then that he wrote his famous 'Outlines of Astronomy,' which was a new edition of a little book he had written years before. In this great work Sir John Herschel first taught ordinary people what a grand science astronomy is. Before his time the different discoveries and theories had been scattered about in various scientific papers, too difficult and too tedious for the public to read. But Sir John wrote simply and plainly about the great truths which had been worked out, from the days when Aristarchus first asserted that the earth moved round the sun, to the time when Sir William Herschel pictured our whole solar system travelling onwards through endless space; and through his book many who would never otherwise have studied the science learnt to know something of the wonders of the heavens and the lessons they teach. Sir John was a true lover of the works of nature, and he taught all his readers to love them too, and to feel a true reverence for the Infinite Mind of the Creator of them all. He died in 1871, and was buried in Westminster Abbey, but never will those who knew him forget the beautiful truth-loving spirit which breathed in every word he wrote or spoke.

**Discovery of the Paths along which Meteors travel, and the Agreement of two of these with the Orbits of Returning Comets, 1862.**—We must now turn to a most interesting discovery made within the last twenty years, which proves that our solar system does not consist merely

of the sun and the planets, with their satellites, but that myriads of smaller bodies are also moving in large orbits around our sun. Every one has heard of falling or shooting stars, and most people have probably seen one or more of these bright meteors rush across the sky on a calm summer evening, and then vanish as suddenly as it appeared. The rude Lithuanian peasants have a touching legend about these falling stars. 'To every new-born child,' they say, 'there is attached an invisible thread, and this thread ends in a star; when that child dies the thread breaks, and the light of the star is quenched as it falls to the earth.' Science has taught us a different, but a not less wonderful history. It is now known that these meteors are solid stones, 'pocket planets' as Humboldt called them, which form long elliptical rings round the sun, many of which cross our orbit in various directions. When we pass through one of these rings, the stones rush through our atmosphere so fast that they become heated, and give out light for a short time, till they disperse into fine dust and vanish. When they are too large to be consumed before they reach the earth, they fall, often with great violence, and are split into countless fragments. A large collection of these meteoric stones is to be seen in the British Museum, some weighing hundreds of pounds, others only a few grains. They have been analysed, and are found to be composed chiefly of iron, tin, sulphur, phosphorus, carbon, and oxygen.

Before the present century all that was known about these bodies was very vague and unsatisfactory. From time to time accounts of stone-falls came from different parts of the world, but they were not much attended to, and people found it difficult to believe that stones and mineral masses actually fell from the sky on to the earth. But in 1803 a fiery globe was seen to rush over the town of Aigle, in Nor-

mandy, and a stony mass was dashed to the ground and shattered into thousands of fragments, some of which weighed as much as  $17\frac{1}{2}$  lbs. This created so much astonishment that the French Government sent M. Biot, a celebrated French chemist, to examine into the matter, and he reported that there could be no doubt of a shower of hot stones having fallen upon the earth.

From this time more interest was taken in meteors and meteoric stones. People had remarked for a long time that shooting-stars were more abundant from the 9th to the 11th of August than at other times, and more lately it was also noticed that a shower of the same kind happens about the 13th of November. Astronomers began, therefore, to think that these meteors must move in regular orbits, crossing the orbit of our earth in certain places, so that we pass through them. There were also reasons for thinking that the November meteors travelled in an enormous ellipse, passing at one end even outside the planet Uranus.

It was not, however, till thirteen years ago that anything was really known. In the year 1862 an Italian astronomer named Schiaparelli made a very remarkable suggestion. He noticed that a comet which was seen in that year crossed the earth's path just at the point where we are always in the middle of the meteor-shower on August 10, and it occurred to him whether it might not be possible that the August meteors were travelling in the same orbit as the comet. His suggestion turned out to be correct, and by a calculation which we cannot follow here, he proved that the *comet and the August meteors travel along precisely the same path* in the shape of a long ellipse passing at one end outside the planet Neptune, the most distant of the known planets. This was the first time that the orbit of any set of meteors had been traced out.



The next was that of the November meteors, which was determined by Adams, and also independently by Leverrier. It had been shown by searching out all the past accounts of November showers that in times gone by the earth passed through these meteors a little earlier in the year than she does now, and this could not be accounted for by any irregularity in the movement of the earth. It looked therefore as if the orbit of the November meteors must be slowly shifting, just as the orbits of the planets do, within certain limits. It was upon this shifting that Adams founded his calculations, and he worked out the meteor path with great accuracy, showing that those astronomers had been right who thought it extended beyond Uranus. This time the problem was solved by pure astronomical reasoning, but perhaps the most remarkable part of the story is that in 1866, long after Adams had determined the orbit, a new comet was seen, which was found to move exactly along the path of the November meteors, in the same way that the comet of 1862 agrees with those which fall in August.

Although these two meteor-showers are the most important, they are by no means the only ones crossed by our earth. Mr. Proctor states that on any clear night, if you watch carefully, you may see about six shooting-stars in one hour; and Professor Newton, of America, has calculated that 7,500,000 meteors large enough to be seen without a telescope pass through our atmosphere in one single day and night. At least a hundred sets of meteors, or meteor-systems as they are called, are known to astronomers, and each one of these is composed of millions of bodies; and you must bear in mind that these systems do not move round us, but round the sun, so that it is only because we happen to cross their path that we know anything of them. It would be idle to suppose that these hundred meteor-

systems which we come across are the only ones existing. On the contrary, we have every reason to think that they are only a few out of thousands of meteor-systems which we never meet, and which probably grow more numerous the nearer they approach the sun.

And so we arrive at the wonderful thought that the whole of our solar system is swarming with meteors collected into more or less defined rings and rushing along with immense speed in their motion round the sun. What their use is we do not know. Some astronomers have imagined that the heat of the sun is kept up by these meteoric stones falling in countless myriads on his face, but this is disputed by others; and for the present it is enough if we can picture to ourselves these rings of meteors whirling round and round in space, and flashing into light as they rush through our atmosphere whenever we happen to cross their path.

I have chosen out these new facts about meteors because, of all modern discoveries, they give the best idea of the wide fields of knowledge which are opening out before us. Within the last fifty years a number of most interesting observations have been made about the nature of the sun itself; but they would require long explanations, and being all the work of living men, they scarcely belong to our history.

---

*Chief Works consulted.*—Airy's 'Report on Astronomy,' British Association, 1833; J. D. Forbes's 'Progress of Mathematical and Physical Science'—Sixth Dissertation; 'Encyclopædia Britannica,' new edition; Guillemin, 'The Heavens;' Herschel's 'Astronomy;' Grant's 'Physical Astronomy;' 'Reports of the Astronomical Society;' 'The Orbs of Heaven,' Mitchell; Proctor, 'On Shooting-Stars and Meteors.'

## CHAPTER XXXIII.

## SCIENCE OF THE NINETEENTH CENTURY (CONTINUED).

Dr. Young explains the Interference of Light—Malus discovers the Polarization of Light caused by Reflection—Fresnel—Polarization of Light explained by Young and Fresnel—Sir David Brewster and M. Biot on colours produced by Polarization—Fizeau—Foucault—Velocity of Light.

WE must now go back to the history of Light, which we left, as you will remember, at the end of the seventeenth century, at the point which Newton and Huyghens had reached. During the whole of the eighteenth century very little was learnt about this science, and it remained for the men of our own time to make the next step and to discover the grand laws of light which we must now consider. It will be best to divide our subject into two parts—1st. The discoveries which have led to a true *Theory of Light*. These are very difficult to understand, and you must not expect to gain more than a slight notion of them; 2d. The new facts lately discovered about the *Chemistry of Light*, and called Spectrum Analysis, and of these I hope you may understand enough to fill you with delight at the beautiful histories they reveal.

**Discovery of the Interference of Light by Young, 1801.**—You will remember that Newton and Huyghens had proposed two different theories of light (see page 174).

Newton's, called the Corpuscular or Emission Theory, supposed light to be made of minute particles darting out from the sun and every light-giving body. Huyghens, on the contrary, taught that light is produced by the vibrations or waves of an invisible ether which is supposed to fill all space. This was called the Undulatory or Wave Theory.

Newton's authority was so great, and the experiments he made to prove his theory were so striking, that the 'Corpuscular theory' was generally received as the true one, especially as Huyghens had only made a few simple experiments in support of his idea; and it was more than a hundred years after Huyghens first published his 'Treatise on Light' before a man arose to defend the Undulatory theory and to bring it again into notice. This man was Dr. Thomas Young, the first Professor of Natural Philosophy at the Royal Institution of London.

Thomas Young, who was the son of a Quaker, was born at Milverton, in Somersetshire, in 1773, and died in 1829. He was brought up at home, and seems to have been a very clever lad, for he knew seven languages at the age of fourteen, besides having studied Natural Science as an amusement. He then went to the Edinburgh University, where he worked under dear old Dr. Black, whose enthusiasm, no doubt, helped much to increase his love of science. When he was only twenty he sent a paper on 'Vision' to the Royal Society, and was elected a member the following year. He then went to Cambridge in order to be able to satisfy the College of Physicians, and practised as a medical man in London, where, in 1801, he was also made Professor of Natural Philosophy at the Royal Institution, which had just been founded, and Editor of the Nautical Almanack. He is very famous as one of the first men who deciphered the Egyptian hieroglyphical writings, and you will often hear

him mentioned as an Egyptian scholar ; but what we have now to consider are his discoveries about Light.

Young tells us himself that it was in May 1801 that he first made an experiment which seemed to him to prove that light must be a succession of tiny waves moving across space as Huyghens had supposed. His experiment was the following. He made a hole in the window-shutter of a dark room, and covered it with a piece of thick paper, in which he had pricked a small hole with a needle. He then put a small looking-glass outside the shutter, so as to throw the sunlight very fully upon the hole and send a cone of spreading light through it. In this cone of light he held a very narrow strip of card and watched the shadow which it threw on the wall, or on another piece of card behind it. On each side of the shadow there were some faint fringes of colour, but besides these he saw *in the shadow itself* dark and light upright tinted bands, which finished off in a faint white band in the middle of the shadow. It was from these faint bands, which many men would have thought not worth noticing, that Young worked out the truth of the Wave Theory of Light.

The first question he asked himself was—‘Why should there be any light at all in the shadow?’ This was not difficult to answer, for as light travels in all directions, a part of it, passing on each side of the strip of card, will spread out behind it. But why should this light arrange itself in stripes and not fall equally all over the shadow? It seemed at first impossible to explain this ; but when Young placed his hand so as to prevent the light passing along one of the edges of the card he found that the *fringes or bands disappeared entirely*, and when he took away his hand they returned. It was clear, then, that so long as the light passed in one direction only behind the card it spread itself out

equally, but directly the two sets of rays from the two sides met each other, dark and light bands appeared.

Now Newton's emission theory could give no explanation of this curious fact, for if light were made of tiny particles there is no reason why these particles, in crossing each other, should make dark bands. On the contrary, the more of them there were the more light there ought to be. The Undulatory or Wave Theory, however, explained the bands perfectly, and this we must now try to understand.

You will remember that Huyghens supposed an ether filling all space to be set in motion by the sun, or any other luminous body, and to heave up and down in tiny waves, just as the sea heaves, or the water of a pond, when you agitate it.

Suppose, therefore, that a number of waves of water, all of the same size, are moving along one side of a lake as at A, Fig. 57, p. 315, and flowing out through a narrow channel at the end, and suppose another set of waves to be moving along the other side, B, so that the two sets meet at the mouth of the channel. Then, if the two waves *c* and *d* are both rising up when they meet, they will join together into one large wave, and will continue to flow in large waves down the channel. But if they meet, as in Fig. 58, when *c* is falling and *d* is rising, then *c* will flow into the hollow of *d* and fill it up, and instead of a large wave being made, the surface of the water will soon become smooth.

Now Young pointed out that this is exactly what happens to the undulations of light. After passing through the hole in the shutter, they move on till they come to the card, and here they wheel round each edge of the card and meet behind it. Those which meet in the middle of the shadow have each travelled exactly the same distance with the same number of waves, so they meet as in Fig. 57, and a strong undulation is produced, causing a band of light. But on

either side of the exact middle the rays will not have travelled exactly the same distance, but one will have made half a wave more than the other, so they will meet as in Fig. 58, and destroy each other, causing a band of darkness. Outside these again the ray which has come the longer distance has had time to make up another half-wave, so it meets the other ray as a friend again, and both of them rising together, a strong wave and a light band is the result. In

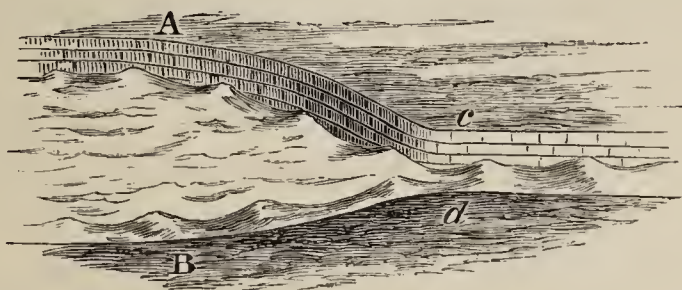

FIG. 57.

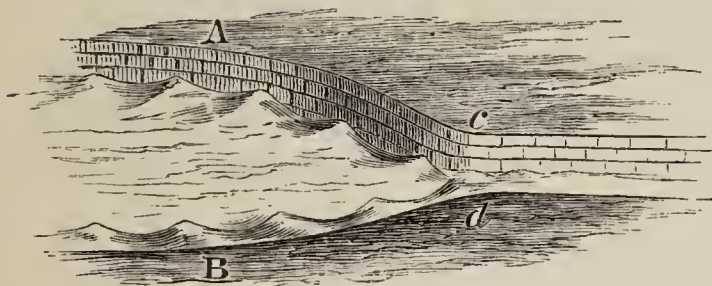

FIG. 58.

Diagrams illustrating the Interference of Waves.

In Fig. 57 the waves,  $c d$ , meet in the same phase, and produce strong undulations.

In Fig. 58 the waves,  $c d$ , meet in the opposite phase, and interfere with each other.

this way they go on, first helping and then *interfering* with each other, and thus making alternate bands across the shadow. For this reason Young called his discovery the '*Interference of light.*'

If this experiment is made with light of one colour only, as, for example, with light which has been passed through red glass, and so is composed only of red rays, then the bands are simply black and red. But if sunlight is used,

another curious effect is seen, namely, a succession of bands appear tinged with the colours of the rainbow ; and this, too, Young showed to be beautifully explained by the Undulatory Theory. It was stated at p. 177 that the colour of the light which reaches our eye depends upon the rapidity of the vibrations of the ether, just as the sound of a note upon our ear depends upon the rapidity of the vibrations of the air. Consequently the waves of the prismatic colours are of different lengths, so that when the two rays of light meet behind the card the waves of the various colours do not all arrive together. For example, those waves which cause us to see the colour violet are much shorter and more rapid than those which cause us to see red. Therefore, when the red waves meet each other as friends (as in Fig. 57), and make a strong vibration, the violet ones will meet each other as foes (as in Fig. 58), and interfere with each other ; and so we shall see a bright red stripe made by the strong red wave, while the violet waves will be destroyed. A little farther on the violet waves will meet as friends, and then we see a violet streak, while the red ones will in their turn be destroyed.

**Colours on the Soap-bubble.**—The beautiful colours of the soap-bubble are caused in this way, and an explanation of them will help you to picture to yourself this effect of the interference of light. If you have ever blown a well-shaped soap-bubble, and watched it settle down quietly where there is no wind to disturb it, you cannot fail to have noticed the colours which appear upon it. If the bubble is very perfect, these colours arrange themselves in rings, beginning with a dark spot at the top of the bubble and forming alternate bands of blue, yellow, orange, and red, which grow fainter and fainter down the sides of the bubble till they disappear. The reason of these colours is that,



when the sunlight falls on the thin film of the bubble, a little of the light is reflected straight back to the eye from the surface *a*, Fig. 59; but most of it passes on to the second surface *b*, and there again some is reflected, so that two sets of waves are constantly reaching the eye, one from *a* and one from *b*. These two sets meet before they come to our eye, and we have just seen that it depends entirely *how* they meet what colour we see.

Suppose the film is just thick enough for the two rays

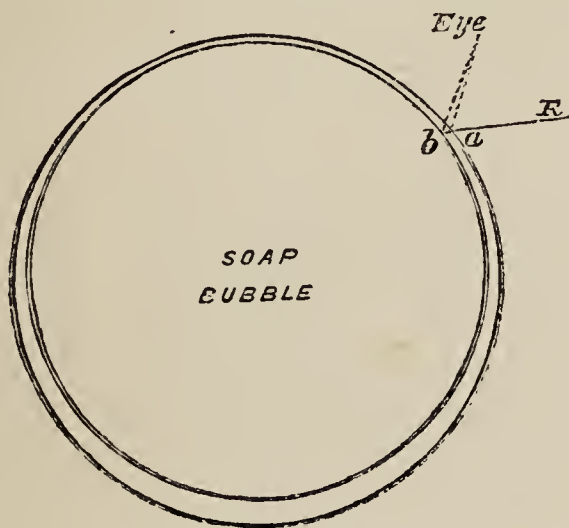

FIG. 59.

Reflection of Light from the two surfaces of a Soap-bubble.<sup>1</sup>

R, Ray of light, part of which is reflected from the surface *a*, and part from the inner surface, *b*, to the eye.

to meet when the red waves of each are *rising*; we shall then have a full *red* wave upon our eye. But in that case, as the *violet* waves are a different length, they will not have met as friends, but as foes, one *up* and the other *down*, and will destroy each other; and so will the waves of all the other colours, because they are not of the same length as the red waves. Therefore the only impression on our eye

<sup>1</sup> The film of a soap-bubble is really only the thickness of a fine line even in the thickest part; but it was necessary to exaggerate the two surfaces in the diagram to show the passage of the ray of light.

will be that of red. But the bubble is always growing gradually thicker down its sides because the soapy liquid is creeping downwards. So a little lower down the red waves from the two surfaces *a* and *b* will no longer fit each other, but will meet unevenly and the red colour will be destroyed. It will now be the turn of the violet rays to combine and make a strong wave to our eye; a little lower down it will be the turn of the green waves, then of the yellow, and then the film will be thick enough for the red waves to come together again, and so it will go on; each colour in its turn will produce a strong wave, while all the others are quenched, until the film is too thick for the effect to be produced.

This is a very rough idea of the way in which the Undulatory Theory explains the colours which we see in shadows and in the soap-bubble. When you study the subject of light you will see how very complicated these wave movements really are; but without special knowledge you cannot understand more than I have given you here. The colours on mother-of-pearl, on a duck's neck, on the transparent wings of insects, and even on the scum floating on a pond, are all produced by the interference of light, and we owe the discovery of this simple and beautiful explanation to Dr. Thomas Young.

**Malus discovers the Polarization of Light by Reflection, 1808.**—The next step in the science of light was made by Etienne Louis Malus, a young French engineer officer, who was born in 1775, and died in 1812, when he was only thirty-seven years of age. He was a most accomplished mathematician, and if he had lived longer, would probably have been one of the most celebrated men of our century.

You will remember that in 1669 a Danish physician named

Bartholinus discovered that a ray of light is split into two rays in passing through Iceland spar in any direction except along the axis of the crystal; and that Huyghens explained this by saying that the crystal was more elastic in one direction than in another, so that the waves moved at different rates through it (see p. 179). To understand Malus's discovery you must also remember that one of these divided rays, if it falls upon a second crystal in the same manner as the first, goes on its way as a single ray, but if the second crystal is turned round a little the ray splits up again into two rays.

In the year 1808, M. Malus was standing at his study window in the Rue d'Enfer, in Paris, looking through a prism of Iceland spar at the sunlight reflected from the windows of the Luxembourg Palace, which stood opposite. All at once he observed to his surprise that he saw only one image through the prism instead of two. Turning his prism a little, he got the two images again, but one was much brighter than the other, and when he turned the crystal a little farther the other image disappeared, and he had only one again. In fact, the light which was reflected from the window at one particular angle ( $56^{\circ} 45'$ ) behaved just like one of the divided rays which has come out of a crystal, and not like an ordinary ray which comes from the sun.

This remarkable peculiarity puzzled Malus greatly, and led him to make a great many experiments, by which he discovered that, whenever light is reflected from glass at this particular angle of  $56^{\circ} 45'$ ,<sup>1</sup> it has the peculiar characters of a divided ray which has passed through Iceland spar. Light reflected from other substances is also divided up in this way, only the angle at which this change takes place is dif-

<sup>1</sup> The polarizing angle of glass varies between  $45^{\circ} 35'$  and  $58^{\circ}$ , according to the nature of the glass.

ferent for each different substance. Malus was the first to call this peculiar effect *polarization*, and light which behaves in this way has since been always called 'polarized light.'

His discovery led to a completely new study, for people had almost forgotten the experiments which had been made by Huyghens more than 100 years before; but this novel and curious fact attracted attention, and the subject was taken up again. Malus did not live to explain the matter; he found out many remarkable facts about it, but it was Young and the French philosopher Fresnel, who really worked out the theory of the polarization of light.

**Polarization of Light explained by Young and Fresnel, 1816.**—Augustin Fresnel, the contemporary and friend of Thomas Young, was born at Broglie, in France, in 1788. He was a delicate backward boy, who disliked books, but loved practical experiments, and he followed his tastes by becoming an engineer. Being a Royalist, however, he was harshly treated by the Emperor Napoleon I., and he retired to Normandy to devote himself to science. He died of consumption in 1827.

It is very difficult to decide whether Young or Fresnel was the first to point out how certain peculiar vibrations of the ether explain the polarization of light. But fortunately this need not trouble us, for the men themselves were not anxious to dispute about their claims. Young's discoveries were very coldly received in England, for very few men understood them; and unfortunately Lord Brougham wrote some severe articles against them in the 'Edinburgh Review,' which made people think they were only foolish speculations. But in France two men, Fresnel and his friend M. Arago, understood and valued Young's labours as soon as they heard of them, and from that time the three

men helped each other in every way without the least jealousy as to who should have the credit of the work.

Fresnel had puzzled out the question of the 'Interference of Light' before he heard that Young had done so too; and it happened that while Fresnel and Arago were one day making experiments upon the way in which waves of light interfere with each other, they found that the ordinary and extraordinary rays which come out of a piece of Iceland spar cannot be made to *interfere* with or quench each other, as may happen in the case of two ordinary rays. (See p. 315.) This led Fresnel to suspect that the waves in the two rays must move in a different manner. He wrote this to Dr. Young, and found that he also had the same idea; and this led to a number of experiments, by which they proved at last that a natural ray of light is not composed merely of upright waves as in A, Fig. 60, p. 322, but also of waves from side to side as in B, and others at every angle between these two, so that the ray is really round and not flat; when light is polarized, this complex vibration is destroyed, and the waves of each ray move only in one plane.

To understand this, take a piece of string, and, fastening one end to the wall, hold the other end in your hand. If you now move your hand up and down, you will make waves in the string which will point up to the ceiling and down to the ground, making what are called *vertical vibrations* (A, Fig. 60). Stop this movement, and then move your hand from side to side; the waves will now point from wall to wall in *horizontal vibrations* (B, Fig. 60). If you then move your hand so that it points to the ceiling to your right, and the floor to your left, you get waves between the two others, and so you can go on varying the position of the waves in all directions; or, in scientific language, you cause the string to *vibrate in different planes*.

Now Young and Fresnel proved that a natural ray of light is composed of all these different waves moving at the same time, some up and down, some from side to side, and some between the two. But when the light passes through a piece of Iceland spar, there are two and only two ways in which the waves can move : one up and down—and along this path one ray of light goes ; the other from side to side at right angles to the first—and along this the other ray goes at a different speed, and so they become divided.

You can imitate this by passing your string through a card with a straight slit in it. Place the card upright, as at A, Fig. 60, and it is clear that the waves will be up and

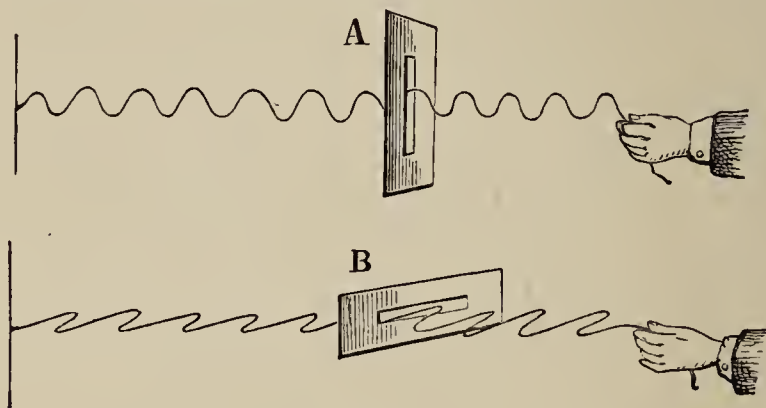

FIG. 60.

Diagram illustrating the passage of Waves of Light through a crystal.  
A, Waves moving in a vertical plane. B, Waves moving in a horizontal plane.

down ; place it sideways, as at B, and the waves will be from side to side. These two positions of the card imitate the two paths of a ray of light through a crystal, and they show how the difference in the peculiarities of the divided rays is caused by their moving in a different plane.

We cannot follow this out more completely in a history, for the polarization of light is a very difficult subject ; but this was the first step made in it. Fresnel afterwards worked out accurately why, when light is reflected at a certain angle, the vibrations are all made to move in one

plane, and so the light is polarized, as Malus had found it to be from the surface of the Luxembourg windows. He also showed how in some crystals, as in quartz crystals, the waves are made to act upon each other, so that, instead of moving to and fro, they wind round and round like the wire of a corkscrew. These and many other experiments, as, for example, those upon the beautiful colours caused by polarization, were carried much farther by the eminent French chemist, M. Biot (born 1774, died 1862), and by Sir David Brewster (born 1784, died 1868), but they are too long and difficult to be explained here. As I said at the beginning of this chapter, the 'Theory of Light' requires a special study, and if you have understood something of the movement of the supposed ether waves—how they can interfere with each other and produce light or darkness, how they produce coloured rings in the soap-bubble, and how their vibrations are altered in passing through a crystal or in reflection at certain angles—you have learnt as much as can be easily grasped of the discoveries of Young and Fresnel.

**Velocity of Light in Air and Water—Fizeau—Foucault.**—It is necessary, however, to mention here one strong proof of the wave-theory of light although the detailed experiments are too complicated to understand without long explanation. M. Fizeau and M. Leon Foucault, eminent French physicists, have invented two different methods by which the velocity of light can be accurately measured. M. Fizeau's depends upon the rotation of a toothed wheel behind a slit which cuts off a reflected ray, or allows it to pass, according to the rate at which the wheel is turned. M. Foucault's depends on the rotation of a small mirror revolving round an axis in its own plane like a coin upon its edge, by means of which the spot of light from a ray changes its position perceptibly in the minute interval of time occupied by the

reflection of the ray. By means of these methods it is possible to measure very accurately how long a ray of light takes in passing through any medium. Now, if Newton's 'Corpuscular Theory' had been true, a ray ought to pass more rapidly through water than through air, but on the Undulatory Theory the opposite should be the case. MM. Fizeau and Foucault have, however, found that light will travel four miles in air in the time that it will only travel three miles in water, thus giving almost demonstrative proof that the undulatory theory of light is the true one.

---

*Chief Works consulted.*—Young's 'Lectures on Natural Philosophy,' 1845; Peacock's 'Life and Works of Young;'; Arago's 'Éloge of Fresnel;'; Herschel's 'Lectures on Familiar Subjects;'; Tyndall, 'On Light;'; Spottiswoode's 'Polarization of Light;'; Whewell's 'Inductive Sciences.'



## CHAPTER XXXIV.

## SCIENCE OF THE NINETEENTH CENTURY (CONTINUED).

Spectrum Analysis and its Applications to Terrestrial and  
Celestial Bodies.

**History of Spectrum Analysis, 1800-1861.**—We now come to the history of *Spectrum analysis*, or the study of the various coloured bands produced by different kinds of light when seen through a prism. This is certainly one of the most wonderful discoveries of our century, and though its history is difficult, partly because it belongs to our own time and is going on even now, yet we may learn something about it. The first step was made, as you will remember, when Newton discovered that white light is composed of different coloured rays, but even he little suspected what histories those rays could be made to tell.

**Discovery of Heat-rays by Sir William Herschel, 1800.**—One of the first facts which was learnt in this century about the spectrum was, that the coloured band which is seen when a ray of white light is passed through a prism does not give us the whole of the dispersed ray; for there are many invisible rays at both ends of the coloured part which are very active, though we cannot see them.

It had always been thought that the hottest rays must be those, such as the yellow ones, which give the most light, and in the year 1800 Sir William Herschel, wishing to try

this, took a thermometer and passed it gradually from one end to the other of the coloured band. The result was curious. He began at the violet end of the spectrum (Plate I. No. 1, p. 330), and, as he expected, the thermometer rose higher and higher as he approached the yellow part; but to his surprise it did not stop here. When he passed on through the yellow into the red, the heat still increased, and even became more intense as he passed out of the coloured band altogether into the darkness beyond. By this experiment he found that the heat-rays extend for some distance beyond the red colour, and that they are strongest in that part where no light is to be seen.

**Discovery of Chemical Rays by Ritter, 1801.** — Soon after Sir William Herschel had discovered the dark heat-rays, a still more remarkable fact was brought to light about the violet end of the spectrum: The Danish chemist Scheele, whom you will remember as one of the discoverers of oxygen (see p. 230), had once remarked that nitrate of silver will turn black if the violet rays of a spectrum are thrown upon it. In 1801 Professor Ritter, of Jena, was repeating this experiment, and he found that the black patches appeared slightly on those parts of the paper where the violet rays fell, but very strongly indeed *beyond* those rays where the spectrum was quite dark. So that at this end also there are invisible rays, and these have the extraordinary power of decomposing or breaking up nitrate of silver, and some other substances, so as to leave distinct marks upon anything touched by them.

**Photography.**—You will see at once that this is the secret of Photography. In 1802, Sir Humphry Davy and Dr. Thomas Wedgwood suggested that pictures might be taken in this way by the rays of the sun acting upon chloride of silver, and they even succeeded in making some. But

they could not prevent them from fading away again, and it was not until 1839 that a Frenchman named Daguerre learnt how to fix the pictures so that they would remain, and Mr. Fox Talbot afterwards improved the process.

Photography is now chiefly worked with dry plates, but the old wet process will best illustrate how the rays of light produce a picture. In this process the glass plate which is to receive the picture has been first covered with a thin film of collodion (that is gun cotton dissolved in ether and alcohol) and then bathed in a solution of nitrate of silver.

When you stand in front of it and it is uncovered, a luminous image of your face or body, which has been brought to a focus on the lens of the camera, falls upon the plate, and the chemical rays (which are chiefly those beyond the violet end of the spectrum) decompose the nitrate of silver. You can see nothing when the plate is taken out of the box in which it was placed, but by pouring some more chemicals called protosulphate of iron and pyrogallic acid upon it, the parts which the light has touched all start out in different shades, exactly in proportion as the chemical waves of light have fallen upon them strongly or feebly. The picture will be exactly the opposite to your real appearance, because where most light has fallen, there the chemicals will be most decomposed and will leave the blackest tints.

Another fluid called hyposulphite of sodium is next poured upon the plate to dissolve away any nitrate of silver which remains, so that when the sun next falls upon it it may not blacken the rest of the plate and destroy the picture. Then the glass plate is again placed in the sun with paper under it which has been sensitized, that is soaked in a solution of chloride of sodium and nitrate of silver; and now the shades are reversed. Under the dark parts of the plate the sun will

act feebly on the paper, and produce light patches, while through the light parts it will act strongly and produce shadows. And in this way the lights and shades of your image will appear in their right places on the paper. The printed sensitized paper is now bathed in hyposulphite of soda, which dissolves off the unaltered chloride of silver, leaving the photograph permanently printed in reduced or metallic silver. All this work is done by those chemical rays which are chiefly at and beyond the violet end of the spectrum, and this explains why bright red and yellow objects come out dark in a photograph, because these colours contain so few of those particular chemical rays, while the darkest blue and violet come out nearly white, because they act strongly upon the nitrate of silver.

It was formerly thought that the chemical rays of the spectrum acted almost entirely at the violet end, but Captain Abney has discovered that by using a peculiar film of silver bromide, he can produce photographic impressions by rays far into the red of the spectrum, showing that the chemical action does not so much depend upon peculiar rays as upon the sensitiveness of the molecules of certain substances to the different rates of vibration in the various parts of the spectrum.

**Wollaston first observes the Dark Lines in the Spectrum, 1802.**—In the same year that Ritter discovered the chemical rays at the dark end of the spectrum which have given us the whole art of photography, Dr. Wollaston, one of our most celebrated chemists (born 1766, died 1828), first saw the dark lines in the spectrum which have enabled us to discover the actual materials which exist in the sun and stars. Dr. Wollaston, who made many good experiments on light, was one day examining ordinary daylight through a prism, and instead of letting in the light by a round hole

or large slit in the shutter as Newton had done, he made only a *very thin* slit, so that the colours of the spectrum were prevented from overlapping each other, as they had done in Newton's experiment. The result was that seven dark upright lines or spaces appeared in the band of colour, which seemed to show that no light fell on those parts. Wollaston did nothing more than point out the existence of these lines; but in 1814 Fraunhofer, a German optician, who had heard nothing of Wollaston's experiment, discovered them over again independently, and learnt more about them.

**Fraunhofer, 1787-1826.**—Joseph Fraunhofer, the son of a glazier, was born in 1787, at Straubing, in Bavaria. Being left an orphan when quite young, he was apprenticed to a glass manufacturer, who kept him hard at work all day. But he longed so much for knowledge that he borrowed some old books and spent his nights in learning. In the year 1801 the house in which he lived fell down one night and killed all the people in it except young Fraunhofer, and his cries being heard by the people outside, they set to work to try and release him. It happened that Maximilian Joseph, Elector of Bavaria, came to see the accident, and he encouraged the workmen so much, that in four hours the young man was dug out, wounded, but alive. The Elector was so much interested in this narrow escape, that he gave Fraunhofer eighteen ducats, and the lad used the money to buy himself off from his apprenticeship in order to have some free time for study. After this he lived by polishing lenses, and he worked so well that he soon became the master of a business, and was able to spend his spare time in the study of Physics and Astronomy, which he loved passionately. Finally he became manager of the physical laboratory of an academy in the town of Benedictbaiern, near Munich.

**Fraunhofer's Discoveries about the Spectrum, 1814.**

—From having been constantly at work as an optician, Fraunhofer had been led to study the subject of light, and among other experiments he repeated those of Newton ; and it happened that he too used a narrow slit, as Wollaston had done. Thus he also noticed the black lines which divided the colours, and by making his slit very narrow and using prisms of very pure glass he discovered in a ray of sunlight no less than 576 of these black lines. Plate I., No. 2, gives a few of the principal of these, to which he put letters, and which have ever since been called ‘Fraunhofer’s lines.’ As none of these lines appear when the light of a candle or lamp is passed through a prism, Fraunhofer concluded that sunlight must be defective, and some of its coloured rays must be missing. For, as numberless waves of coloured light are passing through the slit and the prism spreads them out so that each set of waves makes an upright image of the slit on the spectrum, if any waves were missing there would be a dark image of the slit instead of a coloured one.

By far the best way of understanding this is to see it for yourself. Sir John Herschel says that a little inexpensive instrument may be easily made with a hollow tube of metal, blackened inside, a prism fixed in it, and a metal plate with a narrow slit fastened across the end of the tube. I have not been able to find so simple an instrument as this ; the cheapest sold by Mr. Browning, the well-known spectroscope maker, in the Strand, costs twenty-two shillings, and with this you may see the black lines clearly when you turn it to the sun. But if this is not to be had, you may gain some idea of the principle of the dark lines by the following illustration. Colour a strip of paper exactly like the continuous spectrum, No. 1, Plate I., and then cut it across into *very narrow* strips and place them in order side by side on

TABLE OF SPECTRA

PLATE I

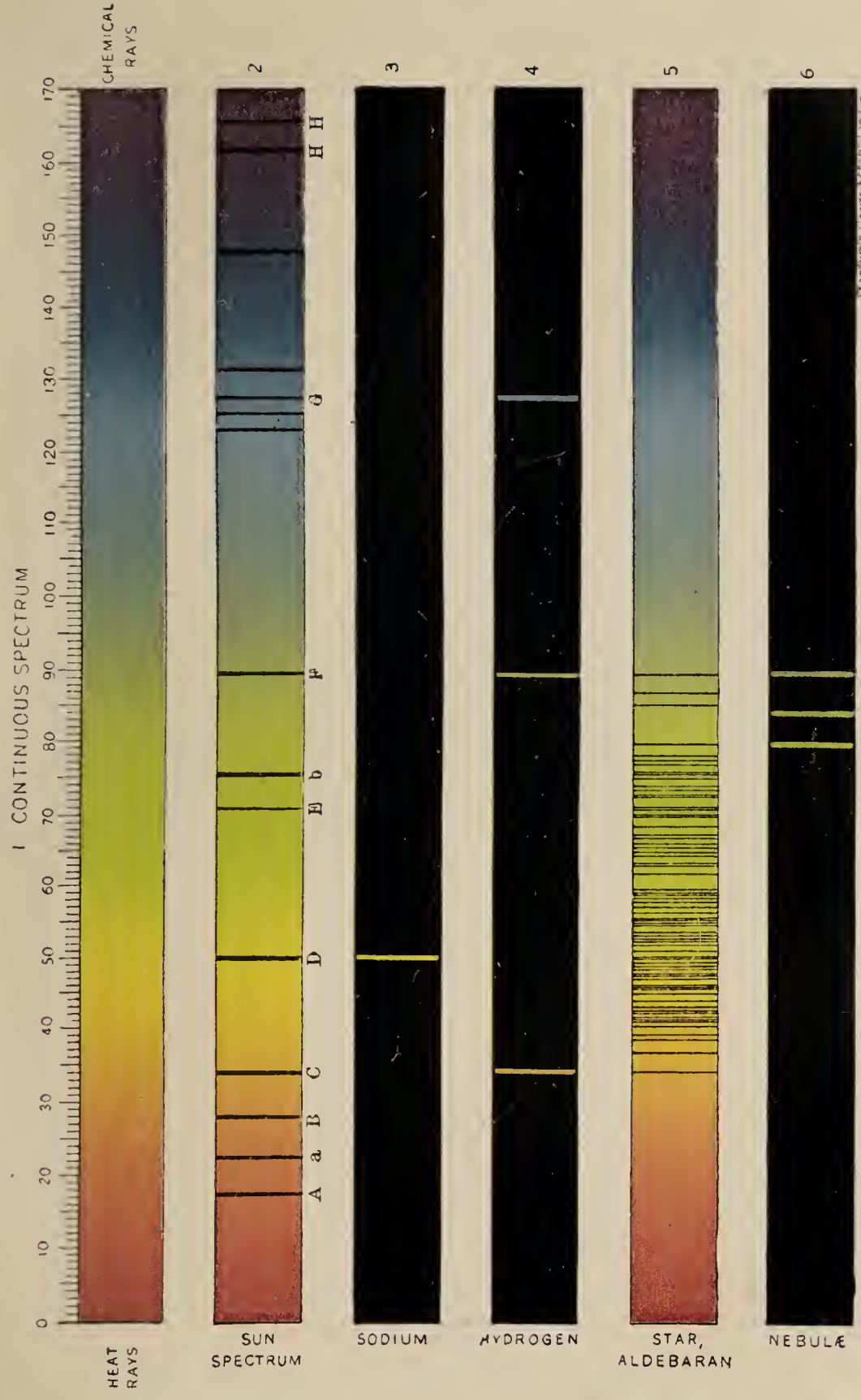

Stanley's Geogr. Est. 1870 - London





a dark ground ; each strip will represent an image of the slit, and the whole will be a continuous spectrum as before. But now suppose one set of waves to be wanting ; take out one of your strips and you will have a dark space. This represents one of the black lines in the spectrum where a dark image of the slit is thrown, and if you take out those which correspond to the lines in the sun spectrum No. 2, you will have an illustration of 'Fraunhofer's lines.'

Fraunhofer measured these black lines with the greatest care, and he found that in every ray of sunlight they came exactly in the same places. Then he tried the light of the moon and Venus ; still the black lines were the same, for these planets, as you know, only shine by the light of the sun. But, when he turned his telescope to the stars and caught their light, he found a difference. There were dark lines in the star-spectrum, but they were not all in the same place as those in the sun-spectrum, as you will see if you compare No. 2, Plate I., with the star-spectrum, No. 5, in which the lines seen on the right-hand side of the solar spectrum are entirely wanting.

Fraunhofer, therefore, argued in this way : If the black spaces were caused by some of the waves being stopped in coming through *our own atmosphere*, they would be the same in any spectrum wherever the light came from. But as these dark spaces are different in the starlight from what they are in the sunlight, *there must be some real difference between the light of the sun and the light of the stars* before it comes to us. This was the first step in the study of the heavenly bodies by means of spectrum analysis.

**Experiments on the Spectra of different Flames, 1822.**—For more than forty-five years these black lines remained a complete puzzle to all who studied the spectrum, but in the meantime Sir John Herschel, Mr. Fox Talbot,

Sir David Brewster, and others, had made many valuable experiments upon the colours produced by different burning lights. You know already that it is possible to make coloured flames by burning certain substances. For instance, if you put common salt in a spirit-flame, it will burn with a yellow colour, while a substance called nitrate of strontium will give a brilliant red flame, and is used in making red fire for the theatres. Many other metals and earths, however, tinge the flame so slightly that you cannot see the colour, and it is only by passing the light through a slit and examining it by means of a prism that you can detect it.

Light from flames and from white-hot solids and liquids when passed through a prism produces a continuous spectrum, that is, a coloured band unbroken by any dark lines. A lighted gas jet, a white-hot poker, or a flow of white-hot molten iron, will all give the continuous spectrum No. 1, Plate I. But gases or vapours, when heated so as to become luminous without burning, do not give a continuous band of colour, they only produce a few bright lines, such as those in Nos. 3 and 4. You can see this by putting a pinch of salt into a candle-flame, and examining it through Browning's little spectroscope. The sodium in the salt will be reduced to a luminous vapour in the flame, and will give the bright line in No. 3 in the table of spectra, standing out from the continuous spectrum given by the candle-flame.

Now there is a remarkable peculiarity about these bright lines formed by gases or vapours, namely, that *they are different for the gas or vapour of every different substance*. Thus, if you burn any substance containing sodium, a bright yellow stripe will appear as in No. 3; while hydrogen will give one red, one blue, and one violet stripe, as in No. 4. This test is so true and delicate that the hundred and eighty-millionth part of a grain of sodium will give the

yellow line ; nor does it matter if many incandescent gases are mingled together, for *the vapour of each one will give its own lines without interfering with the others.*

It was Sir John Herschel in 1822 who first suggested that by reducing substances to incandescent gases in a flame, and marking the bright lines which they produced, it would be possible to detect the most minute quantities of any metal or earth which they contained, and Mr. Fox Talbot carried out this suggestion in 1834. By this means in the course of time, spectroscopists, or men who made the spectrum their study, were able to map out accurately the coloured lines of every known substance ; and what is still more wonderful, new metals were actually discovered by the new bright lines they threw on the spectrum. The first two of these new metals, called *Cæsium* and *Rubidium*, were discovered by Bunsen and Kirchhoff in 1860 ; the third, called *Thallium*, which throws a beautiful green line, was found by Mr. Crookes in 1861 ; the fourth, called *Indium*, which gives two indigo-coloured lines, was first seen by Richter and Reich in 1864 ; and a fifth, called *Gallium*, was discovered by M. Lecoq de Boisbaudran in 1875. Thus spectrum analysis gives us an entirely new and sure way of analysing or discovering the different elements in any substance.

**Bunsen and Kirchhoff explain the Dark Lines in the Sun Spectrum, 1861.**—But for a long time no one could solve the question of the black lines in the solar spectrum. Sir David Brewster came very near to it once, but just failed to hit upon the truth.<sup>1</sup> At last, in 1861, only

<sup>1</sup> Sir William Thomson states in his address to the British Association in 1871, that Professor Stokes gave the true explanation of these lines in his lectures at Cambridge in 1851, although he did not publish anything about it, and his idea was not generally known. Balfour Stewart had also shown in 1858 that a body absorbs the same kind and amount of light and heat rays which it radiates when heated.

fourteen years ago, Bunsen and Kirchhoff, two celebrated professors of chemistry and physics at Heidelberg, discovered the secret.

These two men had been making a long set of careful experiments upon all the different substances of our globe, burning them and examining their vapours one by one, and marking the bright lines of each upon the spectrum. In doing this they did not use one prism only as Fraunhofer had done, but four (see Fig. 61), so arranged that the light coming in through a slit at the beginning of the

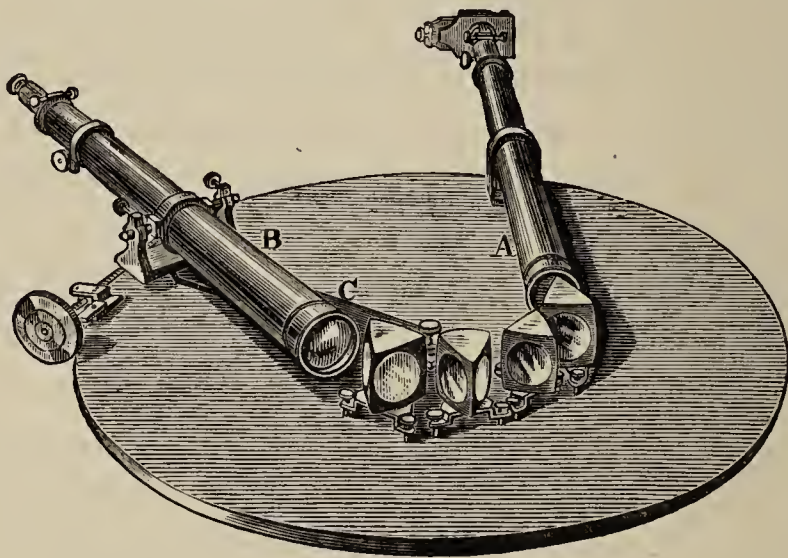

FIG. 61.

Kirchhoff's Spectroscope (Roscoe).

tube A, was spread out more and more through each prism as it passed, and fell in a spectrum on the object glass, C, of the telescope B, through which they examined it. They soon found that in order to mark the exact position of the bright lines of each gas upon the spectrum, they wanted some fixed measure, and it occurred to them that the black lines of the solar spectrum, which never change, would make a good scale with which to compare all the others. So they arranged their spectroscope in such a manner that one-half

of the slit was lighted by the sun and the other half by a luminous gas. In this way No. 2, Plate I., would appear above, and No. 3, for example, immediately below it.

While doing this they could not help remarking that the bright yellow line of the sodium spectrum, No. 3, was exactly in the same position as the black line,  $\text{D}$ , in the solar spectrum;<sup>1</sup> and Kirchhoff found that when he passed a faint ray of sunlight through luminous sodium vapour (so as to make the two spectra, 2 and 3, cover each other), the yellow line exactly filled the black line with its light. He now wished to see how bright he could make the solar spectrum without overpowering the light of the sodium, so he let the full sunshine pass through the sodium flame. To his great astonishment he saw the black line at  $\text{D}$  start out more strongly than ever. The sodium light while being overpowered itself had *absorbed some of the yellow light of the sun!*

This suggested to him the idea that the black line  $\text{D}$  must be caused by the white light from the sun passing through sodium vapour before it reaches us. There was a very simple way of proving whether this were so, for burning solids, you remember, give a continuous spectrum (1, Plate I.); therefore, if he could produce a dark line by passing the light of a burning solid through glowing sodium vapour, he would imitate one of the defects in sunlight. So he burned a lime-light, and when he had the continuous coloured band in his spectroscope, he burned a flame coloured by sodium between the lime-light and the prism. The experiment was quite successful; the dark space,  $\text{D}$ , started out upon the spectrum, and thus he proved beyond doubt that *incandescent or glowing sodium vapour absorbs out of white light exactly those same rays which it gives out itself when glowing.*

<sup>1</sup> This line is really formed of many lines which can be seen in a powerful spectroscope, but it appears single in a small instrument.

He repeated the experiment with other burning metals, such as potassium and strontium, and always with the same result. *Each incandescent gas absorbed out of white light exactly those rays which it gave out itself when glowing.*

The black lines in the solar spectrum were now explained, for each one of them must imply that some particular ray of sunlight has been absorbed by a gas between the sun and us, and it must have been absorbed *near* the sun, as Fraunhofer had pointed out, because the lines are different in light which comes from the stars, showing that in that case it has passed through other kinds of gases. Therefore Kirchhoff concluded that round the solid or liquid body of the sun, which gives out white light, and would of itself produce a continuous spectrum, there must be an atmosphere of gases of different kinds, which absorb or destroy particular rays of light, and prevent them reaching us.

If this is the case, it is clear that we can tell from the lines in the spectrum what gases and vapours there are in this solar atmosphere. For example, there must be sodium which cuts off the rays which ought to come to D, and there must be also iron, magnesium, calcium, chromium, potassium, rubidium, nickel, barium, lead, copper, zinc, strontium, cadmium, cobalt, uranium, cerium, vanadium, palladium, aluminium, titanium, hydrogen, and carbon, for the bright lines of all these metals are wanting in the solar spectrum, showing that the white light from the body of the sun must have passed through their gases.<sup>1</sup> Sir W. Herschel had supposed the sun to be a dark body surrounded by a luminous atmosphere. But we see that spectrum analysis shows just the opposite to be true. The body of the sun

<sup>1</sup> On the 20th of July 1877 Prof. Henry Draper of New York announced the existence of oxygen in the sun, but some doubt still remains upon this point.

must be an intensely heated body giving out light, and if it is composed of gas it must be so dense as to act as a liquid and give a continuous spectrum. This body is called the *photosphere*, or light-giving sphere; and around it lies the solar atmosphere in which the gases above mentioned have been discovered. This atmosphere is supposed to be from 500 to 1000 miles high, and it has still another envelope outside it. In 1842 a white light or corona was seen round the sun when it was totally eclipsed by the moon, and red flames were observed shooting up into it. We do not even now know clearly what this corona is, but the red flames or 'prominences,' as they are called, were studied during the eclipse of 1868 by Professor Janssen in India, and Mr. Lockyer in England, and they both saw two vivid hydrogen lines (see No. 4 Plate II.), together with a third line not yet well understood. The red prominences then are made up chiefly of hydrogen gas, and Janssen and Lockyer proved that they are jets from an envelope of this gas which may be observed everywhere round the sun's atmosphere to a height of 5000 miles. To this envelope Mr. Lockyer has given the name of *chromosphere*, which has been generally adopted.

It is only the bright light from the body of the sun which prevents our seeing this hydrogen envelope at all times, and Janssen succeeded in an ingenious way in making the hydrogen visible even in broad sunlight. He passed the light through many prisms at such angles that it was spread out till it became very faint indeed, and then it no longer hid the hydrogen lines, and they could be clearly seen. The 'red prominences' or eruptions from the chromosphere vary very much both in their height and the time they remain. Some shoot up 15,000 or 20,000 miles in a minute and fall back

like jets of water ; others remain for some days, and Respighi tells us that they reach a height of 80,000 miles or more. Thus we have evidence in the sun of a *photosphere*, or luminous body, in the centre, an *atmosphere* of cooler gases round it which absorbs part of its light and causes the dark lines in the spectrum, and a *chromosphere* or coloured sphere of hydrogen gas which throws out jets of enormous height into a *corona*, the nature of which is as yet very imperfectly understood. The spots on the sun which Galileo noticed have also lately been much studied, especially by De la Rue, Balfour Stewart, and Loewy : they appear to be hollows which open from time to time in different places in the body or *photosphere* of the sun. We cannot discuss them here, but spectrum analysis has helped to prove that they are depressions.

The solar spectrum has now been mapped out with wonderful accuracy, and the name of Professor Angström, of Sweden, will always be remembered as one of the most able workers in this path.

**Dr. Huggins and Dr. Miller examine the Stars by Spectrum Analysis, 1862.**—Only a few months after Kirchhoff had proved that the black lines in the solar spectrum reveal to us what elements exist as gases around the sun, two English chemists, Dr. Miller, who died a few years ago, and Dr. Huggins, who is still living, began to try the same experiments with the other heavenly bodies.

Their instruments were now much more perfect than those which Fraunhofer had used, and they were able to see the effects of our own atmosphere upon sunlight. When the sun is setting and its light has to pass through a long layer of air before it reaches us, faint lines appear on the spectrum, because some light is absorbed by the watery vapours in our atmosphere. Now, when Miller and Huggins examined the light which comes from Jupiter, they found



three or four lines like those caused by our atmosphere, showing that Jupiter must have an atmosphere partly, but not entirely like ours. Mars and Saturn also both showed these atmospheric lines, and so did Saturn's rings, proving that a similar atmosphere must spread over them also. But our moon gave none of them, and this agrees with other evidence in showing that the moon has no atmosphere.

They next passed on to examine the light of the stars, and this was by no means an easy task, because the stars are so far off that their light is very faint and difficult to catch. Nevertheless they proved that round one star, called Aldebaran (No. 5, Plate I.), there must be an atmosphere of hydrogen, sodium, magnesium, calcium, iron, tellurium, antimony, bismuth, and mercury, and you will notice that the last four of these are not found in the sun. In the light of the star Betelgeux in the constellation Orion, and in another star, called  $\beta$  Pegasi, no hydrogen is found, but it is found in all the other stars that have been examined, together with many other substances. In some of the stars there are besides lines which must be produced by the vapours of substances different from any yet known upon our earth.

**Dr. Huggins proves that some Nebulæ are Gaseous, 1864.**—And now we come to a very interesting experiment. You will remember that astronomers doubted Sir W. Herschel when he suggested (p. 285) that some of the nebulæ are not made of tiny stars, but of gas which is forming into stars. In 1864 Dr. Huggins began to examine these nebulæ with the spectroscope, and he found that they did not give a band of colour with dark lines upon it as the stars do, but *a few faint coloured lines on a dark ground*, such as we know are produced by glowing gases and vapours. If you compare the spectrum of sodium (No. 3), or of hydrogen

(No. 4), with the nebula spectrum (No. 6), you will see at once that the nebula spectrum is that of a luminous gas, and so the truth of Sir W. Herschel's idea was proved, and there can be now no doubt that the light of some of the nebulæ comes from gaseous matter; chiefly, so far as we can learn, of nitrogen and hydrogen.

**Mr. Alexander Herschel examines the Spectrum of Falling Stars.**—I have said that it was difficult to examine the spectrum of the stars and nebulæ, but something which to an ordinary observer seems still more wonderful has been lately done. Mr. Alexander Herschel and others have actually caught the light of *falling stars* in the spectroscope, and in this way have discovered that some of them give a continuous spectrum, showing that they are incandescent solid bodies, while others give a gas spectrum, on which are the bright lines of potassium, sulphur, and phosphorus, and sodium.

Such wonderful facts as these about far-distant suns and sun-matter, we have learnt, and are still learning by means of spectrum analysis. The whole study was only begun fifty years ago, and it is in the works of living men that you must look for the details of its history. But though many eminent names are connected with it, those of Fraunhofer and Kirchhoff should always be remembered as the chief founders of the science.

---

*Chief Works consulted.*—Roscoe's 'Spectrum Analysis;' 'Edinburgh Review,' vol. cxvi.; 'Philosophical Magazine,' 1860; Proctor, 'The Sun;' Tyndall's 'Lectures on Light;' 'Half-hours with Modern Scientists;' Kirchhoff's 'Researches on the Solar Spectrum,' 1862; 'Encyclopædia Britannica,' art. 'Optics;' Ganot's 'Physics;' Wollaston, 'On Dispersion'—'Phil. Trans.' 1802; Lockyer, 'The Spectroscope.'

## CHAPTER XXXV.

## SCIENCE OF THE NINETEENTH CENTURY (CONTINUED).

Early Theories about Heat—Count Rumford's Experiments—Davy's Experiments—Mayer—Dr. Joule on Mechanical Equivalent of Heat—Indestructibility of Force, and Conservation of Energy—Dissipation of Energy.

**Early Theories about Heat.**—From Light we will now pass on to Heat, and in this chapter I hope to show you how the philosophers of this century have discovered what heat is. The subject in itself is so vast that a mere sketch of all the men who have worked at it and their chief experiments would fill a volume of this size, and you must clearly understand that we can only select those examples which will best enable you to comprehend the nature of heat, and how it has been determined.

Have you ever asked yourself what heat is, or why the mercury in a thermometer rises when it is put into hot water? The old philosophers considered heat to be a fluid, which passed out of substances when they were too full of it, and which, entering the mercury of the thermometer, swelled it out and made it rise. This was the general idea about heat up to the end of the eighteenth century, although Lord Bacon, more than two hundred years before, had suggested that it was not a fluid but a movement, and the philosopher Locke, in the seventeenth century, and Laplace in 1780, gave the same explanation.

Still most scientific men looked upon heat as a fluid, which they called *caloric*, until, in the year 1798, Count Rumford first showed by experiment that it is probably a kind of motion. In following strict chronological order, this discovery ought to have been mentioned at the end of the eighteenth century, but it belongs so intimately to the modern theory that it comes more naturally in this place.

**Count Rumford shows that Heat can be produced by Friction, 1798.**—Benjamin Thompson, afterwards Count Rumford, was born in America in 1753. He spent his early life fighting in the English army against the Americans, in the War of Independence, and afterwards settled at Munich, and became aide-de-camp to the Elector of Bavaria. In 1798 he came over to England, where he was one of the founders of our Royal Institution, and finally he died in Paris in 1844.

Rumford's inquiries into the nature of heat began in rather a curious way. He was very anxious to make the poorer people in Bavaria happier and more prosperous, and to accomplish this he persuaded the Elector of Bavaria in 1790, to forbid any one to beg in the streets. Those who could not find work for themselves were taken up and kept in a kind of workhouse, where they were given good food and clothing, but were forced to work to pay for their own support. When this law was first passed, there were no less than 2500 beggars to be provided for, and Rumford was obliged to calculate very closely how he could find food and clothing, heat and light, for the least money. Accordingly he studied how fireplaces could best be built to prevent coal being wasted, and invented a lamp which gave a brilliant light, without burning so much oil as other lamps did. He even went so far as to make a complete set of experiments on different clothing materials, in order to see

which kept in the most heat. It was in this way, and especially in using steam for warming and cooking, that he first began to study the properties of heat, and he became much interested in the different ways in which it may be produced.

It happened one day, when he was boring a cannon in one of the military workshops of Munich, that he noticed with surprise the great heat produced by the grinding of the borer against the gun. You can easily make a similar experiment by boring a hole quickly with a gimlet in a piece of hard wood, and on withdrawing the gimlet you will find that it is hot enough to burn your hand. Rumford examined carefully the gun and the chips which fell from it, and found that they were both hotter than boiling water.

This led him to consider how it could possibly happen, if heat were a fluid, that the mere rubbing of two metals together should produce it; and he tried many experiments to find out whether the gun, the chips, or the borer had lost anything in consequence of having given out heat. But he could not discover that they were changed in any way; and moreover, he found that by going on boring he could make them give out heat as long as he liked, whereas if he had been drawing a fluid out of the metals it seemed to him that it ought to come to an end sooner or later. Then he considered whether the heat could come out of the air, and to avoid this he repeated the experiment under water, but still the metals grew hot, and even made the water warm, so it was clear they had not drawn any heat from that fluid.

He now began to suspect that Bacon and Locke might be right, and that the rubbing together of the two metals might set their particles vibrating in some peculiar way so as to cause what we call heat. If this were so, then by great friction he ought to be able to produce any amount of heat, and to prove this he tried the following experiment.

He took a large piece of solid brass the shape of a cannon, and partly scooped out at one end. Into this he fitted a blunt steel borer, which pressed down upon the brass with a weight of ten thousand pounds. Then he plunged the whole into a box holding about a gallon of water, into which he put a thermometer, and fastening two horses by proper machinery to the brass cylinder he made them turn it round and round thirty-two times in a minute, so that the borer worked its way vigorously into the brass. Now notice what happened: When he began the water was at  $60^{\circ}$  F., but it soon grew warm with the heat caused by the friction of the borer against the brass. In one hour it had risen 47 degrees up to  $107^{\circ}$  Fahr.; in two hours it was at  $178^{\circ}$ , and at the end of two hours and a half *it actually boiled*.

‘It would be difficult,’ writes Rumford, ‘to describe the surprise and astonishment of the bystanders on seeing so large a quantity of water heated and actually made to boil without any fire,’ and he adds that he himself was as delighted as a child at the success of the experiment; and we can scarcely wonder, for he had proved the grand fact that *heat is not a substance but a peculiar kind of motion*.

Rumford afterwards calculated that the friction caused by one horse pulling round the cylinder against the borer was sufficient to raise 26 lbs. of ice-cold water up to the boiling point in two hours and a half, thus showing that the heat obtained has a definite relation to the energy expended by the horse.

**Davy makes Two Pieces of Ice melt by Friction in a Vacuum, 1799.**—Only a few months after Rumford had made the discovery that heat can be produced by friction, Sir Humphry Davy, whose history as a chemist you will read in Chapter XXXVII., proved the same thing by a different experiment. He took two pieces of ice, and by rubbing

them together made them melt without any warmth being brought near them. In this case, as he said, no one could think that the heat came out of the ice, for ice holds less heat than water; and in order to be quite sure that it did not come out of the air, he made a second experiment. He took a small piece of ice and put it in a machine under an air-pump, by means of which he drew out all the air; then he set his machine to work so that it rubbed against the ice, and in this way he melted the whole lump, without any air being present.

**Heat a Vibration.**—From these experiments Davy came to the conclusion ‘that heat is a peculiar motion, probably a vibration of the corpuscles (that is the little particles) of bodies, tending to separate them.’ Thus for example, when you put a saucepan full of water on the fire, the quivering motion which is going on in coals as they burn passes into the iron of the saucepan, and through it to the water. Immediately all the little particles of which the water is composed are pushed asunder as if they were trying to get away from each other; but as they are still held together by the force of attraction, they vibrate to and fro, struggling more and more to get free, and it is this motion which causes in us the feeling of heat when we come in contact with it. Then, if a thermometer be placed in the water, the vibration passes on through the glass of the tube into the mercury, and the particles of mercury are also set in motion, and so the mercury swells and rises in the tube.

**The Cause of Latent Heat explained.**—And now, if you will look back for a moment to Chapter XXVIII., and read again about the ‘latent heat’ which puzzled Dr. Black so much, you will see how beautifully it can be explained by this theory that heat is a kind of motion. You will remember that, however much heat he put under a piece

of ice he found that the temperature of the water would not increase above  $0^{\circ}$  Cent. so long as a morsel of ice remained unmelted; and again, that boiling water never grew hotter than  $100^{\circ}$  Cent., while it was being turned into steam. Now if we look upon heat as a vibration, we can understand that the motion which is sent into ice from the fire below will all be employed in overcoming the force of attraction and separating the particles of ice so as to turn the solid into a fluid, and it will only be when the last particles are free that there will be any movement to spare so as to produce the quivering motion of heat. Then if you go on heating the water still more, the struggling movement will continue between the force of attraction and the force of motion, and so the water will grow hotter and hotter, till at last at  $100^{\circ}$  Cent. the force of motion wins the battle, and the little particles fly asunder and float away as steam; and from that moment all the extra movement is employed in forcing asunder particle from particle, till all the water has passed away in vapour.

It was for this reason that Watt had to use so much more cold water to cool down steam of  $100^{\circ}$  Cent. than to cool down water of  $100^{\circ}$  Cent.; for in cooling down steam he had not only to get rid of the quivering motion of heat, but of all the extra force which was holding the particles asunder.

**Dr. Joule's Experiments on the Mechanical Equivalent of Heat, 1849.**—It had now been shown that energy could be converted into heat. In Rumford's experiment the energy had been derived from the horse, and in Davy's case from himself, as he rubbed the pieces of ice or worked the machine. But neither of these experiments measured accurately the amount of energy which produced a given quantity of heat. Rumford had, indeed, made a rough



calculation ; but when a horse walks round and round, we cannot measure how much strength he gives out, and in order to prove that energy by itself can produce heat we must measure exactly how much work produces a definite increase of temperature,—say of  $1^{\circ}$  Fahr.—and then see if that amount of heat can be turned back again into work. This was done by Dr. Joule, of Manchester, a celebrated physicist, who is still living.

In 1839 a Frenchman named M. Séguin, and in 1842 a German physician, Dr. Mayer, of Heilbronn, both suggested that by careful experiments it might be found out how much work must be done to produce a certain increase of temperature, and Dr. Mayer made many calculations about it. In 1843, without having heard of Dr. Mayer's suggestion, Dr. Joule, who had previously discovered in 1840 the law of heat evolved by Voltaic electricity, began those famous experiments which have formed the foundation of the *dynamical theory of heat*, or the *theory of heat produced by mechanical energy*, and he completed them in 1849. A description of one of his experiments will explain the results he obtained. He took a weight, A, Fig. 62, p. 349, which weighed 1 lb. and fastened it by strings to the roller, *ff*. On to the wheel, B, of this roller he wound another string which passed round the roller *r*, and this roller was attached to a paddle which was shut into the box of water, c. He next wound up the string on the roller *f*, so as to draw up the weight A, and then set it free. Immediately the force of gravity drew the weight down to the ground, and in doing so pulled round the wheel B, and consequently the roller which turned the paddle in the water. When the weight reached the ground he took out the little pin, *p*, which fastened the paddle to the roller, so that he could wind up his apparatus without disturbing the water and begin again.

Now observe how this measured the work done and the heat produced. Every time the weight fell, it turned the paddle, and so, by agitating the water, added to its heat. The scale, *D*, told him exactly how far the weight fell, while the thermometer, *t*, in the box told him how much hotter the water grew. At the end of an hour, therefore, he had only to see how many feet his pound-weight had fallen, and how many degrees of Fahr. the temperature of his water had risen; and after allowing for the friction of his machinery and for the heat lost in the cooling of his vessel, both of which he ascertained by careful experiments, he could tell how much energy had been expended in producing the rise of temperature. In this way he found that *a weight of 1 lb. would have to fall 772 feet in order to raise the temperature of 1 lb. of water by 1° Fahr.*

He next tried the same experiment with oil and with mercury instead of water, and also measured the heat produced by rubbing together two plates of iron; and in every case he found that a certain amount of work gave a certain amount of heat and no more. For example, if the weight in Fig. 62 fell double the distance, the temperature of the water was raised two degrees instead of one, while if it fell only half the distance, or 386 feet, the water was only raised half a degree.

In this way Dr. Joule established what is called the *mechanical equivalent of heat*, namely that the fall of a pound weight through 772 feet sets free enough mechanical energy to raise the temperature of a pound of water 1° Fahr. And now you must try to form a clear idea what this means. Looking at the diagram, try to picture to yourself what would be taking place if the weight were able to fall the whole 772 feet without stopping. First, a man must wind up the weight, and in doing this he uses working power or energy to overcome the force of gravitation which is pulling

the weight down to the earth; so that the machine starts with a certain stock of energy stored up in the weight, and its amount is called 772 foot-pounds because it has raised a weight of 1 lb. to a height of 772 feet. This stock of working-power philosophers call *potential energy*, or possible energy which may be called into use at any time. When the man sets the weight free, it begins to fall, drawn down by the force of gravity, and the stock of energy is set free. What becomes of it? It passes by the wheel B into the roller  $r$ , and, turning the paddle in the box enters the water.

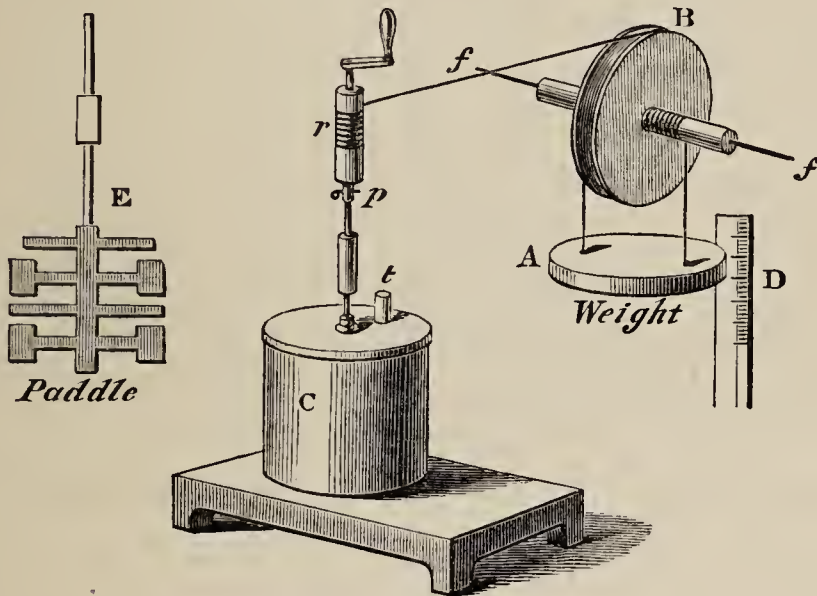

FIG. 62.

Joule's Experiment on the Conversion of Motion into Heat (Phil. Trans.)

A, Weight. B, Wheel of the roller,  $ff$ . C, Vessel containing water and the paddle. D, Scale to measure the distance that the weight falls. E, Paddle contained in the vessel, C.  $ff$ , Roller turned by the falling weight.  $r$ , Roller turning the paddle.  $p$ , Pin which joins the roller and the paddle.  $t$ , Thermometer plunged in the vessel, C.

If the water were free, the motion would pass on into the air and we should lose sight of it; but the water is shut in and the energy cannot escape, so now it employs itself in dashing to and fro all the little particles which make up the water, and producing the effect we will call heat. Thus the

mechanical energy of the weight, derived from the man who wound it up, is expended in fluid friction in the box and thus converted into heat.

**Hirn's Experiments on Heat converted into Mechanical Energy.**—If you have understood this explanation, you will have some idea of the theory that mechanical energy may be converted into heat; but to complete the proof we require not only to turn work into heat, but also to turn heat into work. This had already been done many years before by a French engineer, M. Carnot, though he did not understand its real significance, but it has now been most beautifully proved by a long series of experiments made by M. Hirn, of Colmar, in Alsace. It was already known exactly how much heat could be obtained from every ton of coal consumed. What M. Hirn did was to find out how much of that heat was converted into useful work in an engine. This was by no means a simple task, for much heat is lost in various ways in passing through the engine; and even when he thought he had allowed for all this, it was found that some of the steam had turned back into water on its way, and thus used up some of the heat. At last, however, when all was carefully measured and calculated, he found that if it had been possible to turn all the heat passing through the engine into work, then *for every 1° Fahr. added to the temperature of a pound of water, enough work would have been done to raise a weight of 1 lb. to a height of 772 feet.*

**Conservation of Energy.**—And thus we arrive at one of the grandest discoveries of modern science, namely, that the whole amount of *energy*, or power of doing work, possessed by any set of bodies, remains unaltered whatever transformations it may undergo. It may exist in one of two forms—either as *potential* or stored-up energy, which is

unseen by us, or as *visible energy*, when it is actually performing work ; but while it changes from one form to another its amount never alters. Thus in Joule's experiment the energy stored up in the 1 lb. weight which had been pulled up 772 feet was gradually transformed, as soon as the weight was released, into an amount of heat capable of raising the temperature of a pound of water 1° Fahr. ; while Hirn showed, on the other hand, that exactly this amount of heat would, if it could be turned back again into energy, raise the 1 lb. weight to the height of 772 feet at which it stood before.

The potential energy, or power of doing work, remained, therefore, exactly the same whether it was stored up in the weight or in the hot water. And even though we know that practically some energy disappears at every part of a machine when it is at work, yet this is not lost ; for it turns into heat, or some other form of energy, wherever it disappears as motion. If you grease the wheels of a machine, you will detect this heat beginning to do work again by turning the solid grease into a liquid.

By whatever means, therefore, heat is turned into work, or work into heat, the energy which causes them both remains the same, and this is one out of many proofs that energy cannot be destroyed, but is only lost in one form to reappear in another.

Although the experiments and calculations which have proved heat to be a mode of motion are some of the most interesting which have been made of late years, yet they are by no means the only ones. In 1811 Sir John Leslie carried on a most interesting series of observations on the reflection of heat : and the Italian physicist Melloni has traced the whole passage of heat-rays through different solid bodies. All these discoveries are clearly and simply

described in Professor Tyndall's work on 'Heat,' where you may also find the great additions that he has himself made to the work of these men.

We must content ourselves here with remembering that the physicists of the nineteenth century have shown that heat is 'a mode of motion,' and have traced it through all its many wanderings both in earth, air, and sky. They have even followed it from the sun down to our earth, through the plant-world into the beds of coal which are stored up in our rocks, and back again, when this coal is burnt, to the motion which carries our steam-engines and steam-ships across the world. The great German physicist Helmholtz, to whom we owe the greatest modern essay on the conservation of energy, states that 'a pound of the purest coal gives, when burnt, sufficient heat to raise the temperature of 8086 pounds of water 1° Cent. ;' and from this he calculates 'that the chemical force of attraction between the particles of coal and the quantity of oxygen that corresponds to it is capable of lifting a weight of 100 pounds to the height of twenty miles.' This chemical force was stored up in the vegetables of the coal when they obtained it from the sun's heat ages and ages ago, and now man sets it free to perform the work. 'We cannot create mechanical force,' writes Helmholtz, 'but we may help ourselves from the storehouse of nature. The brook, the wind, which drive our mills, the forest, the coal-bed, which supply our steam-engines and warm our rooms, are the bearers to us of the small portion of the great natural supply which we draw upon for our purposes.'

**Dissipation of Energy—Sir William Thomson.**—But the question still remains whether this natural supply will always be in such a condition as to perform actual work ; and upon this point our great mathematician, Sir William

Thomson, has come to a conclusion which we must try to understand, however imperfectly.

We have already seen when speaking of Hirn's engine that it is impossible to convert all the heat passing through the engine into work. Now, that portion which escapes in the form of heat, although it represents quite as much mechanical energy as it did before, is no longer useful in the same way, because it has become spread out or diffused ; and this happens whenever energy changes its form, whether from mechanical energy into electrical energy, from heat into work, from work into heat, or in any other way. Invariably a certain amount of energy is *dissipated*, or spread out in the form of diffused heat.

The same *amount* of energy remains, it is true, but it is so uniformly distributed as to be no longer available for work ; for heat can only be turned into work when it passes from a hotter to a colder body ; therefore heat spread equally over all bodies in nature is lost as a working power, even though it represents the same amount of energy, which could be made to do work if it could be collected again into a condensed form.

This fact of the *dissipation of energy* was first announced by Sir William Thomson in 1852, and he pointed out that it tends to *let down*, as it were, the working power of nature. We keep up *our* store by deriving fresh heat from the sun, and storing it up in the vegetable world, in wood, and coal, and also in the falling power of water which has been drawn up to the clouds by the sun's heat. But the sun's heat itself, and every operation going on in the universe, is caused by the transformation of energy, therefore dissipation must also go on with it ; and, unless there is some compensating power, the whole universe must be drifting very slowly into a state of rest.

But here we must remember that we are travelling beyond our knowledge. In spite of the great discoveries made in this century as to the nature of the sun, we are still in doubt as to the source from which this heat is derived; still less have we any idea what is the source of that energy by which the heavenly bodies were first set in motion. We speak glibly of the universe, but our most powerful instruments, by revealing at every step in advance that more remains beyond, only open before us an ever-widening prospect, to which we cannot even conceive a limit.

---

*Chief Works consulted.*—Rumford's 'Essays,' vol. ii.—'Friction a Source of Heat,' 1798; Davy's 'Works,' vol. ii.—'Essay on Heat and Light;' Joule's 'Mechanical Equivalent of Heat'—'Phil. Trans.,' 1850; Mayer's 'Forces of Inorganic Nature'—'Phil. Mag.,' 1843; Tyndall's 'Heat a Mode of Motion;' Watts's 'Dict. of Chemistry,' art. 'Heat;' Clerk-Maxwell's 'Theory of Heat.'



## CHAPTER XXXVI.

## SCIENCE OF THE NINETEENTH CENTURY (CONTINUED).

Electro-magnetism—Oersted—Ampère—Arago—Faraday—Thermoelectricity—Seebeck—Schwabe—Spots on the Sun—Sabine—Sun-spots and Magnetic Currents—Electric Telegraph—Wheatstone—Cooke—Steinheil—Morse—Bain.

**Oersted discovers the Effect of Electricity upon a Magnet, 1829.**—We left the history of electricity at p. 262, at the point where Volta had shown in 1800 that two different metals joined by a wire and placed in acid and water will set up a current of electricity flowing from the one metal to the other, and back through a connecting wire. Every *galvanic battery*, that is, an apparatus for producing electricity by chemical action, is made on this principle. You will hear of Grove's battery, Bunsen's battery, Daniell's battery, and many others, all of which have been invented in the present century; but all these are only different and more perfect methods of carrying out Volta's discovery. The next great step in the study of electricity was made by Oersted, Professor of Physics at Copenhagen, in 1820, twenty years after the invention of the voltaic pile.

Hans Christian Oersted was born in 1777, and died in 1851; he was a very eminent man, and wrote many works in Latin upon chemistry and magnetism, but the one discovery which has made him famous was that of *electro-*

*magnetism.* We have seen (p. 53) that the invention of the mariner's compass in the fifteenth century arose from Flavio Gioja noting that a needle which has been rubbed along a piece of loadstone always points north and south. But why should the needle lie in this direction? What force makes it turn round when you leave it free after placing it another way? Ever since the fifteenth century people had asked this question, and when Volta and Franklin showed that electrical currents are constantly passing to and fro in our atmosphere, scientific men began to consider whether it might not be some force like electricity which acted upon the magnet; especially as it had been observed that when a ship was struck by lightning, the needle of the mariner's compass was sometimes thrown quite out of its right position.

Still nothing was really known until the year 1819. In that year, when Professor Oersted was one day making some galvanic experiments at a lecture, it happened that a magnetic needle poised upon a point (as in Fig. 63) was standing near the wire along which an electric current was passing. All at once, when the current was very strong, the needle became excited and began to turn round upon the point. Oersted and his assistants were much surprised at this, and the consequence was that during several months Oersted made a series of experiments by which he proved that *an electric current passing near a magnetic needle will always make it turn round so as to lie ACROSS the path of the current.*

For example, if the bar of copper wire *a b*, supported on the glass rods *e, e*, be so placed that the end *b* points to the north and *a* to the south, then the magnetic needle *c* will lie exactly in a line with the bar, because a magnet always points north and south. But if the two ends of the copper

rod *a, b*, are fixed to the wires of a voltaic battery *d*, Fig. 63, so that an electric current runs along the rod from *a* to *b*, then the north end of the needle will begin to move away from the north towards the west, that is towards the left side of the current; and it will turn more and more as the current grows stronger, till it lies right *across* it, pointing direct east and west.

This was a very grand fact, and it has become the beginning of a new science called *electro-magnetism*, for it shows that electricity and magnetism are connected in some

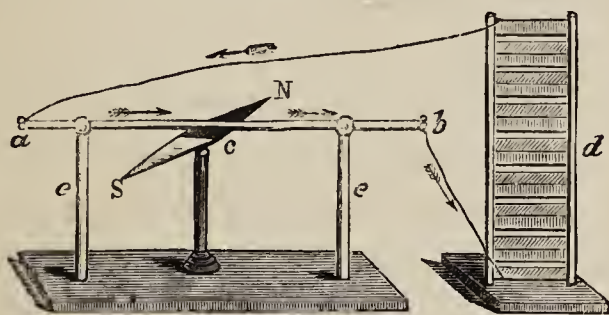

FIG. 63.

Magnet turned by an Electric Current.

*a b*, Rod of copper wire. *c*, Magnetic needle. *d*, Voltaic pile (explained p. 261).  
*e e*, Glass supports to prevent the current running down to the ground.

peculiar way. Oersted did not publish an account of his experiments until 1820, and then the whole of Europe rang with the news of the discovery.

**Ampère, 1775-1864.**—One of the first men who heard of it was Ampère, one of the professors at the *École Polytechnique* in Paris. We must pause a moment to learn something of the early history of this man, for it is very interesting. André Ampère was born at Lyons in 1775. When he was quite a little boy he delighted in arithmetic, and used to do long sums for his amusement by means of little pebbles which he arranged in groups. Once when he had a severe illness his mother took the stones away, but, having left him alone one day for a little time, she found on her return that

he had broken his biscuit into little bits and was using them to work with instead of his lost pebbles. As he grew older his father began to teach him Latin, but the boy disliked it so much that it was given up, and he devoted all his time to Algebra and Euclid.

One day he persuaded his father to take him to his friend, the Abbé Daburon, to borrow the writings of Euler and Bernouilli, two great mathematicians. The Abbé stared at this little boy, only twelve years old, asking for books which very few men could understand. 'Do you know, my little fellow,' said he, 'that these works are written in Latin, and that the differential calculus is used in them?' André's countenance fell for a moment, for he knew neither of these things. But he soon brightened up again. 'Never mind,' he replied, 'I can learn them,' and he set to work that very day to learn Latin with his father, and the differential calculus with the Abbé, and in a few months was able to come back for the books he coveted.

Before he was eighteen he had not only read the whole of Laplace's '*Mécanique Céleste*,' but had even worked out all the complicated problems in it. He had, however, overtaxed his brain, and when his father was killed in the terrible French Revolution of 1793, the grief broke down his intellect. For a whole year he was almost an idiot, and it was a long time before he could take up his mathematical studies again. When he did, it was with his old love of work, and he became a teacher first at Lyons, and afterwards in Paris.

**Ampère's Experiments in Magnetism and Electricity, 1820.**—This was the man who heard of Oersted's discovery in 1820. You can imagine the delight with which he seized upon the new idea. He worked at it incessantly, as he had done with his pebbles when a boy, and before a week was over he had proved several new

facts about electro-magnetism. He found that it was quite true, as Oersted had said, that the magnet always lies across the electric current; but he showed that the north pole of the magnet turns different ways, according to the direction in which the current flows. Thus, if the current<sup>1</sup> flows from *south to north above* the magnet, in the direction *a b*, Fig. 64, then the north pole of the magnet turns towards the west; but if it runs from *north to south above* the magnet, in the direction *a b*, Fig. 65, then the north pole turns towards the east. Again, if it runs from *north to south below* the magnet, in the direction *c d*, Fig. 64, the magnet

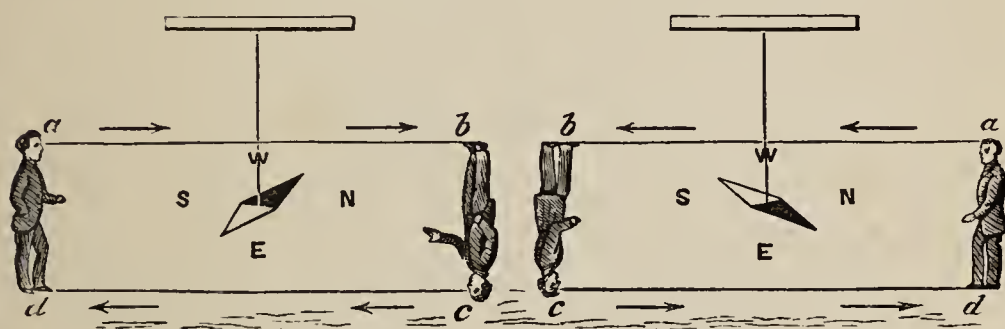

FIG. 64.

FIG. 65.

Diagrams showing the direction of a Magnet acted upon by Electric Currents.

*a b c d*, Direction of current.

will again turn to the west; while lastly, if it runs from *south to north below* the magnet, *c d*, Fig. 65, the north pole turns again to the east. In order to remember these different directions easily, Ampère gave something like the following rule. If a man will imagine himself to be standing so that *the positive current would come out of his mouth and return by his feet*, *the north pole of the magnet will always be on his left-hand side.*

<sup>1</sup> To avoid confusion, the current from the positive pole of the battery is always spoken of as *the current*.

**Lines of Magnetic Force between two Electric Wires.**—The next discovery which Ampère made was a very important one. It was already well known that two magnetic needles will either attract or repel each other according to the position of their poles. Thus, if the north pole of one needle is held towards the south pole of another, they are attracted strongly together, but if the two north poles are brought near together, the movable needle is repelled. Now Ampère argued that if an electric current always exerts a magnetic action around itself, then two electric wires side by side will act magnetically upon each other, or, in other words, will attract or repel each other as if real magnets were lying between them. And this he proved to be true. He put two wires side by side in such a position that they could move freely, and when he sent an electric current in the same direction through each of them they moved towards each other; while, if he sent the currents one way through one wire and the other way through the other, they drew apart; exactly in the same way as magnets attract or repel each other, according to the direction in which they lie.

This may be difficult to understand without more explanation, but you can remember that Ampère proved that *electric currents exert a magnetic force at right angles to themselves in the air without needing any bar of steel to help them.*

**Electro-magnets made by means of an Electric Current.**—It now occurred to Ampère that if electric currents give rise to magnetic force he ought to be able to magnetise a steel bar by passing an electric current round it. So he wound a copper wire (covered with silk to prevent the electricity running into the steel) round a steel bar, and, fastening the two ends of wire to a voltaic battery, he passed

a current through it (see Fig. 66). After a short time he took the bar out and found it was a perfect bar magnet, which would attract iron. The current of electricity, in circulating round the steel, had magnetised the steel just as if it had been rubbed on a loadstone.

With steel the magnetism remained after it was taken out of the electric coil, but if he used a piece of ordinary soft iron the magnetism passed away when the current ceased. He called these magnetised bars *electro-magnets*, because they are made by electricity. You can easily make them for yourself if you have a small electric battery, and you will find that an iron rod will hold up needles, nails, or even keys as long as the current is passing, but they will all fall



FIG. 66.

Coil of Copper Wire conveying an Electric Current round a Steel Bar.

off soon after it stops, showing that it is the electric current which causes the iron to act as a magnet.

Professor Arago, whom we mentioned before (p. 320) as making experiments on light, succeeded in magnetising a steel bar with currents from an ordinary electrical machine, that is, a glass cylinder rubbed against silk, instead of using a battery.

**Michael Faraday, 1791-1867.**—We must now travel back to England, where one of our greatest philosophers was watching these new discoveries with intense interest. Michael Faraday, the son of a poor journeyman blacksmith, was born at Newington Butts in 1791. When he was thirteen years old he went as errand boy to a bookseller named Riebau in Blandford Street, Manchester Square, and it was there that the books fell into his hands which first awoke his love of science. Mrs. Marcet's 'Conversations on Chemistry,'

Lyons's 'Experiments on Electricity,' and other books of a like kind made the lad long for more knowledge about these wonderful sciences. He constructed an electrical machine, and spent his evenings in making experiments, and he persuaded his brother Robert to pay a few shillings for him to attend some lectures given by a Mr. Tatum on Natural Philosophy.

But one of the first great pleasures of his life was when a customer at the bookshop, a Mr. Dance, took him to four lectures at the Royal Institution, given by Sir Humphry Davy. These lectures filled him with an intense longing to learn more, and he took the bold step of writing a letter to Davy, enclosing the notes which he had made of the lectures, and asking for some employment connected with science. It will always be remembered to Davy's honour that he did not throw this letter aside, but wrote a kind reply, telling the young man to come and see him, and in the end made him his assistant at the Royal Institution in Albemarle Street, where Faraday afterwards became Professor of Chemistry.

It is impossible in a short sketch to give you any idea of the simple and noble nature of the man who from that time for more than fifty years laboured at science in the Royal Institution. It is not yet many years since he died, and you may talk with those who have known and loved him, or read the story of his life in a little book called 'Michael Faraday,' written by Dr. Gladstone. Even of his experiments we can only mention a few, for these subjects are becoming almost too deep for us; but those which we must now consider were some which have helped to make his name famous.

**Faraday discovers the Mutual Rotation of Magnets and Electrified Wires, 1821.**—It was in 1821 that Faraday began to repeat for himself Ampère's experiments on



electricity and magnetism, and he soon saw that if an electric current going round a wire gave rise to magnetic action at right angles to it, he ought to be able to make an electric wire revolve round a magnet, and a magnet round an electric wire. Accordingly, he took two cups of mercury, A B, Fig. 67, and drilling a hole in the bottom of each, he passed the wires  $e, e'$ , of a battery up into them; then he took two magnets  $d, d'$ ;  $d$  he fastened by a thin thread to the battery wire in the cup A, so that it floated upright in

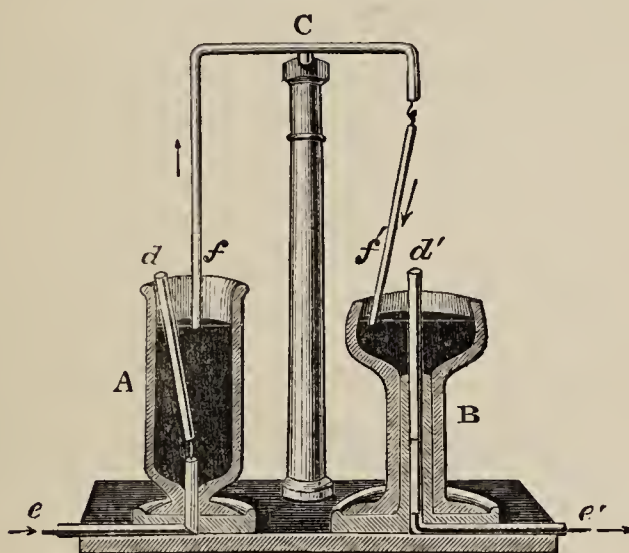

FIG. 67.

Faraday's Experiments on the Rotation of a Magnet and of an Electric Wire.

A B, Section of cups of mercury. c, Copper rod. The current coming in at  $e$  passes up through the mercury in A, and along the rod c down into the mercury in B, and back by  $e'$  to the battery. On its way it causes the floating magnet,  $d$ , to revolve round the rod,  $f$ , and the loose wire,  $f'$ , to revolve round the fixed magnet,  $d'$ .

the mercury, and the top of it could move round easily; the other magnet,  $d'$ , he fixed firmly upright in the cup B. He then hung the copper rod c above the cups, so that the end  $f$ , which was fixed, dipped into the cup A, and the other end, which was made of a loose movable wire,  $f'$ , dipped into the cup B. Thus in A the magnet was free to move

and the wire was fixed, while in B the wire was free to move and the magnet was fixed. He now sent a current through the wires, *e*, *é*, and immediately in the cup A the magnet *d* began to move round the fixed wire *f*, while in B the wire *f'* moved round the fixed magnet, *d'*. Thus Faraday gave fresh experimental proof of the close connection between electricity and magnetism. He made the magnet go a great way round the circle, but not spin quite round as the wire had done. Ampère, however, who repeated the experiment, succeeded in making the magnet spin round and round like the hands of a clock.

**Electric Current produced by Means of a Magnet.**  
Faraday's mind was now full of the wonderful effect which

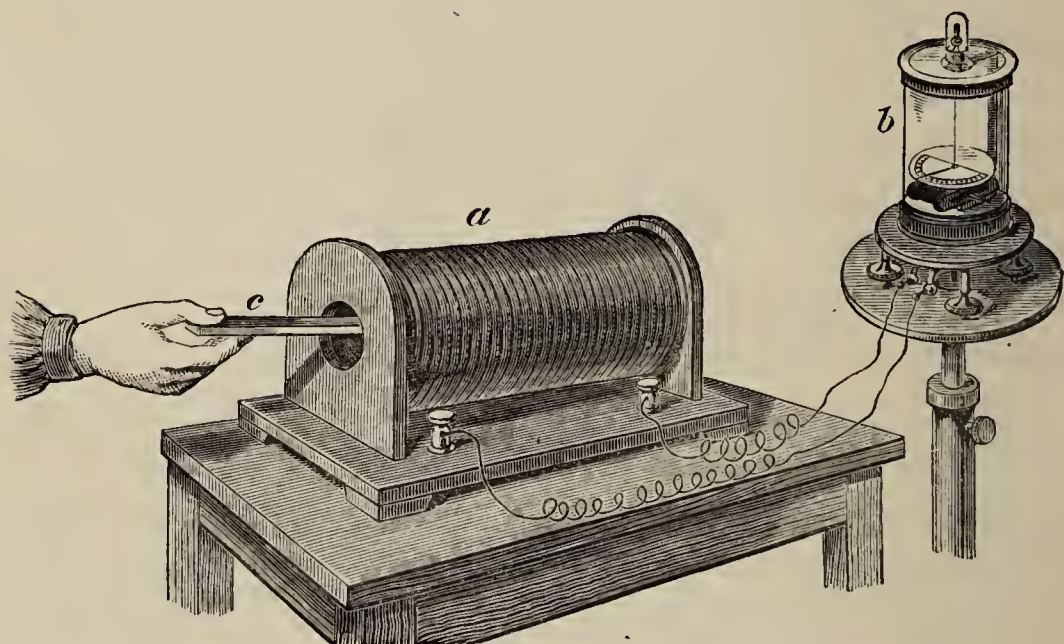

FIG. 68.

Faraday's Experiment on creating an Electric Current by means of a Magnet (Ganot).

*a*, Coil of wire round a wooden cylinder connected at the two ends with *b*, a galvanometer, the needle of which shows directly a current passes through the wire; *c*, a powerful magnet.

electricity and magnetism produce on each other, and he began to consider whether it might not be possible to reverse Ampère's second experiment (p. 361), and instead of making

a magnet by means of an electric current, whether he might not set up an electric current by means of a magnet.

To try this he wound from 200 to 300 yards of wire round a hollow cylinder *a*, Fig. 68, and carried the two ends of the wire to a little instrument *b*, called a galvanometer, which was invented by Ampère, and the needle of which moves directly the slightest current passes through it. He then took a powerful bar magnet, *c*, and held it within the cylinder. The moment he put it in, the needle of the galvanometer showed that an electric current had passed through the wire in one direction, and the moment he drew it out another rush of electricity occurred in the other direction, showing that the magnet had set up an electric current in a coil of wire. While the magnet *remained in* the cylinder there was no current; it was only at the moment of going in and coming out that it produced the effect. By another piece of apparatus Faraday succeeded in making these currents strong enough to produce electric sparks; and it is on this principle that the *induction-coil* is made which is now used to produce very powerful electrical effects.

**Professor Seebeck discovers Thermo-electricity, or the Production of Electricity by Heat.**—The connection was now clearly established between currents of electricity and lines of magnetic action, and this gives to a certain extent the answer to our question, Why does a magnet turn to the north? Ampère suggested quite early in the discussion, that if an electric current will turn metals into magnets, the electric currents which we know are flowing from east to west round our globe may turn the earth (which is full of metals) into a great magnet. But it is also true that exactly the opposite effect is possible, and that the lines of magnetic force may be started by some other cause and may set up the electric currents, so that we do not really know which gives rise to the other.

An interesting discovery was, however, made in 1822 by Professor Seebeck, showing a possible cause of the electric currents flowing from east to west. He wished to try whether he could not give rise to a current of electricity in two metals by merely using heat instead of acid and water. For this purpose he took a half ring of copper and fastened to it a bar of a metal called antimony, so that the two metals had the form of a stirrup, and inside this stirrup he hung a magnetic needle, which would show if any current passed along the metals. Then he heated one of the corners where the metals joined, and immediately the magnet began to turn, showing that an electric current was passing through the copper, and back through the antimony. He tried this with many other metals, and in every case when one of the parts where they joined was made hotter than the rest, a current of electricity was caused. This he called *Thermo-electricity*, or electricity caused by heat, and this subject has now been much more fully worked out by Peltier and Becquerel on the Continent, and Sir W. Thomson, Professor Tait and Clerk-Maxwell in England. Thermo-electricity gives us another beautiful instance of the transformation of energy. We saw in Chapter XXXV. that heat, when it disappears, produces a certain definite amount of energy, which again, in its turn, can appear in the form of heat; since then we have learnt that electricity gives rise to lines of magnetic force, and a magnet sets up an electric current, and now we have heat in its turn giving rise to an electric current, while we know from the electric spark that chemical action can be conveyed by electricity to great distances and then made to reappear as light and heat.

But to turn to the magnet. Seebeck's experiment suggests a possible answer to the direction of the magnetic needle to the north. Our globe is composed of different

metals and earths, and is always turning round from west to east, so that one part after another comes under the heat of the sun, and is made hotter than the rest. Therefore, since an electric current tends to flow round the circuit when the functions of two different metals are kept at different temperatures, it has been suggested that this may cause the electric currents to flow round from east to west, as they did through the metals in Seebeck's stirrup, thus inducing lines of magnetic force from north to south. There may, however, be some closer connection between the sun itself and magnetic action (see p. 369).

**Spots on the Sun, and their effect on the Earth's Magnetism, Schwabe and Sabine, 1825-1859.**—It was mentioned at p. 90 that Galileo and other astronomers of the seventeenth century first observed that from time to time dark spots appear on the face of the sun. These spots were much studied by the astronomers who came after Galileo; but Sir William Herschel was the first to suggest, in 1793, that they were caused by the opening of bright luminous clouds which float round the sun, and break away sometimes in one place and sometimes in another, allowing us to see down through the gap into the body of the sun itself, which has thus the appearance of a dark spot. This is the explanation now received by astronomers as most probable, and it accounts for the constant appearance and disappearance of the spots.

In the year 1826, a well-known German astronomer, Herr Schwabe, of Dessau (who died in 1874), determined to take regular notes of the periods when there were most spots to be seen on the face of the sun. Every day during twelve years, when the sky was clear enough for him to observe the sun, he examined it through his telescope, and noted how many spots he could see.

In this way he discovered that there was a regular decrease in the number of spots for about five years and a half, and then during the next five and a half years a gradual increase, till they were very numerous indeed. This led him to think that the spots went through a complete round or cycle of changes in about eleven years; but as he found it difficult to persuade other astronomers of the fact, he actually carried on his daily observations for twenty years longer, and then, at the end of thirty-four years of daily observation, he was able to assert boldly that he had established the truth of his theory.

He had now kept an account of three periods of eleven years. At the beginning of each of these periods the sun was for some time smooth and almost free from spots: then from year to year they increased, till, at the end of five and a half years, as many as fifty or sixty could be seen at one time. Then they decreased again till, at the end of another five and a half years, the sun's face was comparatively smooth and spotless. During the time that Schwabe was studying these changes, other men in the different observatories of Europe had noticed some remarkable peculiarities about the magnetic needle. As long ago as 1722, a famous astronomer named Graham pointed out that the magnetic needle shifts from side to side a little every day as the sun passes from one side to the other of the globe. The movement is so small that it cannot be seen without very accurate instruments, but it shows that the sun's course does affect the magnet; and when very careful notes began to be made in different observatories, it was noticed that this daily shifting was greater some years than others. In 1850 an astronomer named Lamont, of Munich, pointed out that the movement became greater each year for about five and a half years, and then grew less during the same period; this led Sir

Edward Sabine to suggest that perhaps the spots on the sun had something to do with magnetic phenomena, since they both went through a regular cycle of changes in about eleven years.

And now comes a curious proof of the truth of this theory. In September 1859, when a famous sun-gazer, Mr. Carrington, was observing and measuring the spots on the sun, he suddenly noticed a bright spot break out on the sun's face ; and fortunately another observer, Mr. Hodgson, who was in another part of England, saw this same spot at the same moment. The whole time from the appearance till the disappearance did not exceed five minutes, but when inquiry was made, it was found that the three magnetic needles at Kew, which keep a register of their own movements, had all been jerked strongly exactly at this time. Nor was this all : the magnetic storm passing through our atmosphere at that moment set up such strong electric currents in the wires of the telegraphs all over the world that the signalmen at Washington and Philadelphia received severe electric shocks ; a telegraphic apparatus in Norway was set on fire, and a stream of electric light followed the pen of Bain's electric telegraph, which writes down the message on chemically prepared paper. Moreover, beautiful auroras were seen in both hemispheres, and these brilliant lights are believed to be caused by magnetic currents. The magnetic storms on this occasion lasted for several days, and there could no longer be any doubt that the sun at a distance of nearly 92,000,000 miles can produce a complete hurricane of magnetic disturbance on our earth. This connection of the storms with the sun-spots seems indeed, as I have said, to suggest that the sun has the power of producing terrestrial magnetism in some more direct way than merely through the action of electric currents set

up by the varying heat on different parts of the earth. The whole subject of electricity and magnetism has been carried in the present century far farther than we can attempt to follow it here, for mathematical knowledge is necessary in order to understand its laws as worked out by Weber and Helmholtz in Germany, and Sir W. Thomson and Clerk-Maxwell in England.

**Invention of the Electric Telegraph by Wheatstone and Cooke, 1837.**—We have spoken in the last paragraph of the electric telegraph, and though this is more strictly an invention than a step in science, yet we can hardly close an account of electricity and magnetism without showing how the discovery of these two forces has made it possible for our thoughts to be carried in a few moments of time across land and sea to the most distant parts of the world.

Ever since Volta had shown, in 1800, that an electric current can be sent for any distance along a wire the two ends of which are joined to the poles of a battery, scientific men had speculated whether it might not be possible to use this current for making signals at a distance. But there was always the difficulty of how to make the signs at the other end. In 1816, Mr. Ronalds, of Hammersmith, hung pith-balls on to a wire, which stood out while the current was flowing, and fell down again when it ceased; and many other such plans were tried, but none succeeded well.

When Oersted, however, showed in 1819 that an electric current will cause a magnetic needle to turn from side to side, it was clear that here was a means by which signs could be made at any distance; and accordingly we find that Ampère, in 1830, proposed to work signals by a magnet, and different attempts were made in Europe and America to carry out his idea. The first electric telegraph of any value was patented by Professor Wheatstone and Mr. Cooke



in June 1837; and during the same year Dr. Steinheil, of Munich, and Professor Morse, of America, both invented telegraphs of rather different kinds. I shall not attempt to describe all of these, but only to explain the simplest principle of an electric telegraph as it is used in England, and to show how it depends upon electricity and magnetism.

You will see, if you turn back to Figs. 64 and 65, p. 359, that when the electric current flowed round one way,  $a b c d$ , Fig. 64, the north pole of the needle turned to the west; when it flowed round the other way,  $a b c d$ , Fig. 65, the north pole turned to the east. Now the signals of the electric telegraph depend upon this fact, that the direction of the current alters the direction of the magnet. When one man wants to send a message to another, he does it by sending an electric current from a battery along a telegraph wire, so that it passes a magnetic needle either from right to left or from left to right. When it flows round one way, the needle, even if it is a hundred miles off, turns to the right, when it flows round the other way the needle turns to the left; and it is agreed that so many strokes to the right mean one letter, and so many to the left another letter, and in this way a message can be spelt out, however far off the two men may be.

This is the whole secret of the electric telegraph; but to understand how it works you must follow the explanation of the two diagrams (Figs. 69 and 70) very carefully. Suppose that a message is going between London and York, four things are wanted to convey it:—1. A battery to produce an electric current. 2. A wire to carry the current. 3. A galvanometer, that is a box,  $A, A'$ , holding a magnetic needle to make the signs. 4. A little box called a commutator,  $B, B'$ , in which the position of the wires can be changed so as to send the current first one way and then another.

1. *The battery* is an ordinary chemical battery such as has already been explained.

2. *The wire* is stretched from station to station, resting on little earthenware cups to prevent the electricity running down the poles into the earth, and is arranged in a coil round the magnetic needle at each station in such a way that when the current flows from left to right the needle will turn to the right, when it flows from right to left the needle will turn

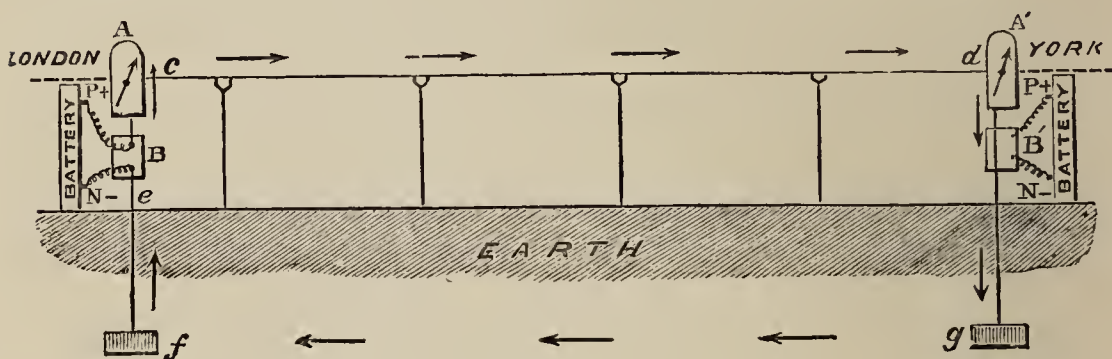

FIG. 69.

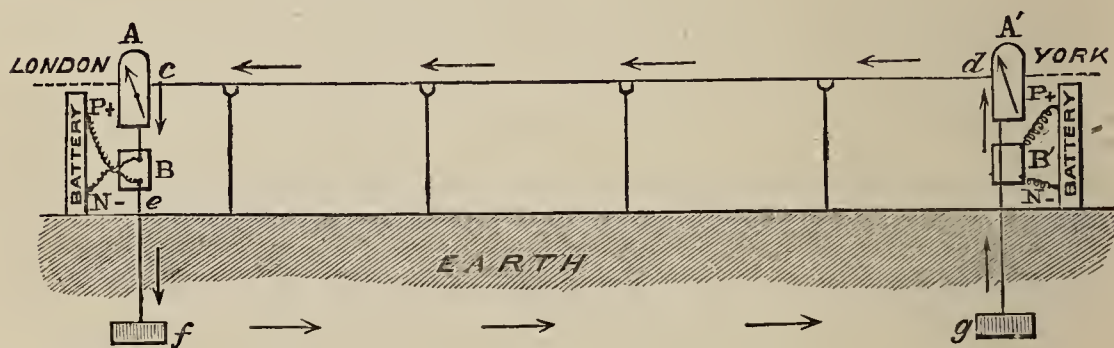

FIG. 70.

Diagrams showing the general principle of the Electric Telegraph.

A, A', Galvanometer, or box containing the magnetic needle. B, B', Commutator, or box in which the telegraph wire and earth wire are joined to each other as in B', or to the battery, as in B. c, d, Telegraph wire. e, Earth wire. f, g, Copper plates at the end of the earth wire. The arrows show the direction of the positive current.

to the left. You will observe that there is only one wire in the diagram, although we know that no current will pass unless there is a complete circuit from the battery, going out at one pole and coming back to the other. At first

telegraphs were made with a second wire to return the current, but Steinheil discovered that this is not needed, for that, if the ends of the wires are sunk in the ground, with plates of copper, *f g*, fastened to them, the earth itself will act as the second wire and carry back the return current to the battery. It is not known precisely how the current returns; it has been suggested that the earth is a great reservoir, as it were, of electricity, so that when the current runs into it at one place an equal amount must run out at another; but all that is really known is that the whole globe acts practically as a return wire.

3. The *magnetic needle* is made of two or more parts, for since it would be very inconvenient if the pointer were always trying to turn to the north, this is avoided by fastening two needles side by side, with the north pole of the one lying against the south pole of the other, and thus, as the earth attracts each needle in a different way, the pull is neutralised. This double needle is called an *astatic needle*, and in the form of telegraph we are describing, it is placed in the box *A*, and surrounded by the wire, while a light strip of whalebone outside the box is so fastened as to show on the face of the dial how the needle is pointing inside.

4. The *commutator*, *B*, is a box with an apparatus inside which is so arranged that by turning a handle (not shown in the diagram) different ways, the earth wire and telegraph wire can be joined together, or either of them can be joined to one of the poles of the battery.

The commutator and galvanometer are really made in one instrument, but I have drawn them separate to make it more clear.

Now, when the man in London wants to send his message to York, he first sends off a current which rings a little bell at all the stations along the line to call attention, and

then spells out the word York. This warns the man at that station to turn the handle of his commutator,  $B'$ , so that the telegraph-wire,  $d$ , and the earth-wire,  $g$ , are joined together. Then the message can be sent. The man in London turns his handle according as he wishes the current to go. In Fig. 69 he has turned it so that the telegraph wire,  $c$ , is joined to the positive pole of the battery, and the current will pass *above* ground along  $c d$  to the galvanometer  $A'$ , turning the needle to the right, and will then go back into the earth, and an equal amount is restored at  $f e$  to the battery. But in Fig. 70 the man has altered the handle, and now the earth-wire,  $e$ , is joined to the positive pole, and so the current passes underground at  $e f$ , and out at  $g$ , and entering the galvanometer on the left side, turns the needle to the left, and goes back by the telegraph wire,  $d c$ , to the battery. In this way he turns it from right to left as he will, and spells out the message thus: Left, right  $\diagup = A$ ; left, right, left, left,  $\diagdown = L$ ; left, right, right  $\diagup = W$ ; left,  $\diagdown = E$ ; therefore  $\diagup$ ;  $\diagdown$ ;  $\diagdown$ ;  $\diagup$ ;  $\diagdown$ ;  $\diagdown$ ; spells '*all well*.'

It is not necessary to have a separate wire for every telegraphic station: one wire will do all the work so long as it is only used by one man at a time, and it has now indeed been found possible to send two separate messages at the same time along one wire. Therefore at every station there is a galvanometer to point out the message, a battery to provide the current, and a commutator to change the current; but these are not joined to the general wire unless they are being used; in Morse's American telegraph, which is generally used on the Continent, the needle pricks holes in a strip of paper, so that the message can be kept; Bain's electro-chemical telegraph writes down the marks on chemical paper; while lately (1879) Mr. Cowper has invented a

telegraphic writing machine, in which the words written at one end are reproduced in facsimile by a pen at the other end of the wire. But all these are only improvements of the same principle by which an electric current going first one way and then another acts on a magnetic needle.

**The Telephone, 1837-1872.**—Wonderful as the electric telegraph is in its power to send messages almost instantaneously across the world, yet within the last few years an instrument still more wonderful, and at the same time even more simple, has been invented. This is the telephone, a small instrument which, when fastened to one end of a

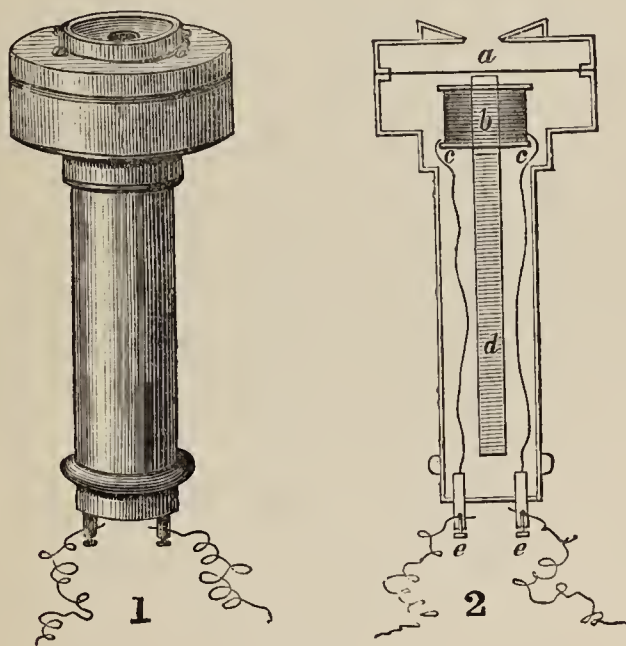

FIG. 71.

1. Bell's Telephone.

2. Section of the same.

*a*, Iron plate. *b*, Soft iron core. *c c*, Coil of silk-covered wire wound round *b*.  
*d*, Permanent magnet. *e e*, Connecting wires.

wire while a similar instrument is fixed at the other end, enables us to talk with a person miles distant from us, so that he can not only hear the words we say but even recognise the tones of our voice.

As usual many men have helped to bring this instru-

ment to perfection. Page in America, de la Rive and Reiss on the Continent, and Varley in England, have all made attempts to produce speaking at a distance, while Elisha Gray of Chicago produced an instrument working with a battery, by means of which vocal sounds could be transmitted. But to Professor Graham Bell of Boston is due the credit of having in 1876 at last succeeded in making a telephone of the simple construction now used. Fig. 71 is a drawing of the telephone with a section of it by the side; one of the wires fastened to the end of the instrument is carried across the country and fixed at the other end to another instrument exactly like it; the other wire is connected with the earth. We have seen, p. 364, that Faraday was able to produce a powerful electric current in a coil of wire by drawing a magnet in and out of the centre of the coil. In Bell's telephone a permanent magnet, *d*, has a piece of soft iron, *b*, fastened to one end of it, and round this soft iron is a coil of silk-covered copper wire. At a little distance from the soft iron bar is placed an iron plate, *a*, with an opening above it in the wooden case enclosing it, and into this opening the person speaks. The vibrations of the voice make the particles of the iron plate or diaphragm vibrate, so that the plate does not move up and down as a whole, but more probably quivers, as it were, throughout its whole surface. This vibration affects the soft iron bar, which, it must be remembered, is not a permanent magnet, but only made so by touching the permanent magnet below. So the magnetisation of the soft iron is altered at every sound according to the rate at which it vibrates and the form of the vibration. This alteration at once sets up electric currents in the coil of wire *c*, and these pass along the wire instantaneously to the person at the other end, even if they are miles away. This person holds an exactly similar

telephone to his ear. The currents pass into the coil *c*, affect the soft iron *b*, and make the iron plate *a* vibrate *exactly* in the same way as the similar plate did at the speaking end. So the same sounds are returned to the air at exactly the same rate and of the same form as the sounds caused by the voice at the other end, and we hear the very tone of our friend's voice, not because the *sound* vibrations have travelled, but because these have been changed into electric currents at one end, and they are changed back again into sound at the other. There are many difficulties still about the working of the telephone; other noises sometimes interfere with the wire and make confusion, and the currents are so weak that a very little disturbance prevents their acting properly, but numerous improvements have been made ever since the above passage was written in 1879, and there are already many kinds constructed very differently from the one I have described. Mr. Edison, the well-known inventor in America, has now constructed a carbon telephone which, when it is put in the circuit of a battery, enables words uttered 115 miles distant to be heard easily by a large audience, and the time may come when speeches made in London may be listened to by crowded meetings in all parts of England.

---

*Chief Works consulted.*—Lardner's 'Cyclopædia'—'Electricity, Magnetism, and Meteorology;' 'Annals of Philosophy,' New Series, 1822, vols. ii. and iii.; 'History of Magnetism;' 'Encyclopædia Metropolitana,' art. 'Electro-Magnetism;' Faraday's 'Experimental Researches in Electricity,' 1859; Tyndall's 'Faraday as a Discoverer;' Gladstone's 'Michael Faraday;' 'Nouvelle Biog. Universelle'—'Ampère,' 'Oersted;' Ampère, 'Observations Electro-dynamiques,' 1822; Faraday, 'Various Forces of Nature;' Proctor, 'The Sun;' Herschel's 'Familiar Lectures;' Brande's 'Manual of Chemistry;' Preece On the Telephone, 'Nature,' vol. xvi. p. 403.

## CHAPTER XXXVII.

## SCIENCE OF THE NINETEENTH CENTURY (CONTINUED).

Sir Humphry Davy—Laughing-gas—Safety-lamp, 1815—Electrolysis—Nicholson and Carlisle—Faraday—John Dalton—Law of Multiple Proportions—Atomic Theory—Liebig—Organic Chemistry.

**Sir Humphry Davy, 1778-1829.**—We saw in the last chapter how Oersted, Davy, Ampère, Faraday, and Seebeck, by their various discoveries, showed the connection between Electricity, Magnetism and Heat. We must now learn how the connection between electricity and chemical change was also worked out. This was done by Sir Humphry Davy and Faraday, who thus put England once more at the head of chemical discovery, in which the French school of Lavoisier had so long taken the lead.

Sir Humphry Davy, whom we have mentioned before as making experiments upon heat, was born in 1778, at Penzance, in Cornwall, and died at Geneva in 1829. His mother being a widow, he was apprenticed when quite young to an apothecary, and there with wine glasses, old medicine bottles, tobacco pipes, and a syringe, he made his first chemical experiments. When he was scarcely twenty years of age, Dr. Beddoes, a physician, who had opened a hospital for curing patients by the use of different gases, heard so much of the young man's abilities that he invited him to come to Bristol, where he employed him in making experiments.



In this way Davy's attention was drawn to nitrous oxide, a gas which had been declared by a celebrated physician, Dr. Mitchell, to be very poisonous. Our young chemist wanted to try this for himself, and actually began breathing it in small quantities to see whether it would affect him. He proved that it certainly was not so poisonous as Mitchell had thought, and, growing gradually bolder and bolder in the use of it, he succeeded at last in breathing the gas for several minutes, at the end of which time he lost all consciousness, and found himself in a land of delicious dreams, out of which he awoke gradually without being injured in any way. Enchanted at having discovered such a delightful sensation, he carried on his experiments for more than ten months, and when he published the results, and told the world that the mere breathing of a gas could make a man sleep, and dream, and laugh without any cause, it created a great sensation, and Davy's name soon became well known.

At this time (1801) the Royal Institution had just been founded, and Count Rumford, seeing that Davy was a young man of great talent, offered him the appointment of Assistant-chemist. Davy accepted it, and from that time devoted himself entirely to science. He was young, bright, and enthusiastic, and his lectures were so clear and eloquent, that the Royal Institution soon became famous under his influence, while every new appliance for making chemical experiments was given him in his laboratory. It was here that he made his observations on flame in 1815, and constructed his Safety-lamp, which has saved so many lives, and for the invention of which he received the title of baronet. It was here also that he made his first experiments in electro-chemistry, which is the only one of his many discoveries of which we can speak.

**Discovery of Electrolysis, or the Decomposition of Substances by Electric Currents, 1800-1806.**—In the year 1800, two men named Nicholson and Carlisle discovered by chance that when the two wires of a voltaic battery were dipped in water, bubbles of gas rose up from them. They also found by experiment that the gas from one wire was oxygen, and from the other hydrogen ; but where these gases came from, whether they were produced by the electricity, or came from the battery, or from the water, they could not tell. Moreover, besides the oxygen and hydrogen which came off, there also appeared an acid of some kind at the positive pole, as was shown by damp litmus paper turning red (see p. 228), and an alkali appeared at the negative pole which turned this red litmus paper blue again. This looked as if the electric current had produced something in the water ; for Cavendish, as you will remember, had shown that pure water is made of oxygen and hydrogen only (see p. 230). Many chemists, therefore, set themselves to try to discover what effect the electric current had on the water, and Davy in 1806 succeeded in solving the question.

The history of his experiments is especially interesting, because it shows, as we have noticed so often before, that a patient and careful inquiry into nature always gains a true answer in the end. Davy did not believe that the electric current produced anything in the water ; he thought that both the acid and the alkali came from the vessels that were used. So he set to work steadily to clear away all possibility of impurities. He took distilled water, and used cups first made of agate, and afterwards of pure gold, because he found that the clay of the china cups was acted upon by the current. Yet, in spite of these and many other precautions, the acid and the alkali still continued to appear. Then he used water which he had evaporated very slowly, instead

of distilling it, because he found that distilled water carried away some salt with it. When he had done this the acid was weaker, but the alkali was as strong as ever. At this point it occurred to him that the alkali might perhaps come out of the air, so he put his gold cups of water under an air-pump, and completely exhausted the air, filling the pump with hydrogen to make quite sure that no other gas could be left in. When he had tried this several times and made it perfect in every way, he succeeded at last in getting nearly *pure oxygen at one pole and hydrogen at the other, while the water decreased in the cups.*

By this experiment Davy not only confirmed Cavendish's discovery that pure water contains nothing but hydrogen and oxygen, but he also established a totally new method of analysing substances, and finding out the materials of which they are composed. This method was in some ways more certain than Bergmann's method of tests, for when you drive one element out by putting another in its place, you have some difficulty in finding out exactly what has happened; but when a substance is decomposed by electricity you literally take it to pieces, and see the elements of which it consists.

**Discovery of Potassium and Sodium.**—Having succeeded in the case of water, Davy now went on to try the effect of the electric current on other bodies, and the first which he took were common potash and soda, which had always been supposed to be simple substances, which could not be decomposed. For several reasons, however, Davy believed that it would be possible to reduce them into more than one substance. So he heated some pure potash in a spoon until it was quite liquid, and fastening the two ends of the spoon to the wires of a battery, he sent an electric current through it. After a little while the potash began to be agitated, and to rise up in bubbles, and then there came to the surface beautiful

silver-like globules, some of which burst into flame, while others remained covered by a sort of white film.

‘Davy’s delight,’ writes his brother, ‘when he saw the minute shining globules like mercury burst through the crust of potash and take fire as they reached the air, was so great that he could not contain his joy—he actually bounded about the room in ecstatic delight.’ It must indeed have been a beautiful sight in itself; but probably Davy’s excitement arose chiefly from the new truth he saw in it. He had proved that potash was not a simple substance, but contained something which had never before been discovered.

At first he had great difficulty in collecting the globules, for they not only burst into flame when they met the air, but even in water they took fire, joining themselves to the oxygen and setting the hydrogen free. At last, however, he succeeded in collecting them in rock oil, or naphtha, which contains no oxygen. He was then able to examine them, and he found they were composed of a metal hitherto quite unknown, to which he gave the name of *potassium*. A few days later he procured the metal sodium out of common soda by the same process.

This method of decomposing substances is called *electrolysis*, which means ‘setting free by electricity.’ Davy made use of it to decompose many earths, such as lime, magnesia, etc., and the great Swedish chemist, Berzelius (born 1778 died 1848), discovered several new chemical substances by means of it.

**Faraday’s Experiments on the Connection between Electricity and Chemical Affinity.**—The power of decomposing substances was the practical benefit obtained by the discovery; but it had another great interest for chemists, because it proved that electricity can overcome that power called ‘chemical affinity,’ which holds two or

more elements together in one compound substance. You will remember that Bergmann, and indeed Newton before him, pointed out that there is some force which causes certain bodies to choose each other out when they meet, and to unite firmly so as to become a new substance which has its own peculiar characters. Chlorine and sodium, for example, when heated, unite to form common salt, which is not the least like either chlorine or sodium when they are separate; and in the same way hydrogen and oxygen unite to form water. In these new states they are held together by a power which for want of a better name we call 'chemical attraction,' or 'chemical affinity.'

Now Davy showed that an electric current conquers this power and sets the different elements free, so that they can each go their own way. Thus the electric current passing through the water overcomes the force which holds the oxygen and hydrogen together, so that, at the point where the battery wires touch the water, hydrogen bubbles come off on one side and oxygen on the other.

It is to Faraday, however, that we owe most of our knowledge about the intimate connection between electricity and chemical change. He followed Davy's experiments, and traced out very clearly the cause and effect of the chemical current. He showed in the first place that a substance cannot be decomposed by electricity unless it is a good conductor, so that the current passes readily along it. Thus, ice being a bad conductor, the slightest film of ice interposed between the water and the electric wires will prevent the current from setting free the oxygen and hydrogen; and ether and alcohol cannot be decomposed at all by electricity, because they will not conduct the current.

He also showed that the electric current itself does not depend upon any effect which the two metals have directly

upon each other, as Volta thought, but is caused by the chemical action going on between the zinc and the water. Thus, if you put some zinc in sulphuric acid and water, the zinc pulls the water to pieces, and hydrogen gas comes bubbling off, but if you coat the zinc with mercury, hydrogen will no longer come off, and no action will take place till you put another metal in the water, as for example a piece of copper, and connect the two metals by a wire. Then the hydrogen bubbles off again, but this time it does not come off the zinc, *but off the copper*. The force which overcomes the chemical attraction in the water has been made to travel across the vessel from one metal to the other, and this journey may be made as long a one as you choose, and may even be continued for hundreds of miles if only the current has some means of finding its way home to the first metal at last.

Now all this is a modified result of the chemical action of the zinc and acid water upon each other; as Faraday proved in a most beautiful way by showing that the power of the electric current to decompose water in another vessel depends entirely upon the violence of the action going on between these two elements of the battery. If the battery is weak, the water in which the ends of the wires are dipped is decomposed slowly; if the battery is strong, the bubbles of oxygen and hydrogen come off rapidly and vehemently. This led him to invent a useful little instrument called a *voltmeter*, which measures the quantity of water decomposed, and so tells exactly what is the strength of the electric current. 'Thus we see,' says Faraday in one of his lectures, 'that the power which decomposes water, or produces the heat and light of the electric spark, is neither more nor less than the chemical force of the zinc—its *very* force carried along the wires and conveyed to another place.'

And here again we find ourselves brought face to face with the truth that all the various physical forces are only different forms of one and the same force. We learnt before that mechanical energy can be turned into heat, and heat into mechanical energy, while heat, magnetism, and electricity all in the same way give rise to each other; and now we learn that chemical change gives rise to electricity, and electricity in its turn to chemical change. So that the whole set of physical forces, heat, electricity, magnetism, and chemical change, are all different phases of the same indestructible energy which we lose sight of in one shape, only to find it in another.

**Methods of Studying Chemistry.**—We have now learnt how most of the chief methods of producing chemical change have been worked out. The science of chemistry consists in using these methods to test and decompose all the substances in our earth and atmosphere, and so learning their nature.

We have seen that there are four ways of thus analysing compound bodies. First, by *testing* them with other substances which attract some of their elements, and draw these out of the compound, as when by plunging a piece of iron into nitrate of copper the iron attracts the nitric acid and draws it out, leaving the copper to fall down as a metal. This was the method chiefly worked out by Bergmann in 1761, and which has since then been brought to much greater perfection by other chemists.

Secondly, by heating substances gently and examining the vapours which rise from them, and afterwards analysing what remains by burning. This method was fairly understood by Geber, and was first applied to organic substances by Boerhaave.

Thirdly, by passing an electric current through a com-

pound substance in a fluid state, and so overcoming the force which holds the different elements together and setting them free. This method, called *electrolysis*, was discovered by Davy in 1806, and afterwards thoroughly worked out by Faraday.

Fourthly, there is the method of spectrum analysis suggested by Herschel in 1822, which was carried on with great success by Bunsen and Kirchhoff. In this method the substance is turned into gas either by ordinary heat or by the electric spark, and is then examined by the spectro-scope; the elements being determined by the position of the bright lines they throw on the spectrum.

There is still a fifth method, about which we have said nothing as yet, and which was chiefly brought into use by the chemist Berzelius, namely the fusing of substances by means of the blowpipe. This instrument is merely a little tube with a mouthpiece at one end and a very minute hole at the other. By placing the minute hole in the middle of a flame and blowing through the mouthpiece, the centre of the flame is made to burn furiously, and many substances can be melted and decomposed by it which do not yield to ordinary heat.

By these different methods a very large number of substances have been analysed since the time of Davy and Faraday, and sixty-four elements or simple substances have been discovered. It is possible that some of these may even at some future time be decomposed and shown to be made up of two elements; we can only affirm that now they appear to us to be simple substances. Some of these elements have been brought together and made to unite into compound substances by artificial means; as when, for instance, oxygen and hydrogen mixed and lighted by a spark rush together and form water, or when hydrogen



and chlorine mixed together and placed in the sunlight unite to form hydrochloric acid.<sup>1</sup> This method of bringing elements together to form a compound substance is called *synthesis*, and is exactly the opposite of *analysis*, or the splitting up of a compound substance into its elementary parts.

To follow out the gradual development of synthesis and analysis, and the discoveries of our great modern chemists, such as Graham, Andrews, and others, would be to write a work upon chemistry. There is only one other general principle which we ought to try and understand here; namely, the proportions in which the elements combine to form substances. This principle, which lies at the root of all our modern chemistry, was first worked out by a poor school-master named Dalton.

**Dalton shows that the Different Chemical Elements always Combine in Definite Proportions.**—John Dalton was born of Quaker parents in 1766, near Cockermouth, in Cumberland. He received the ordinary education of a village school, and after being master of a small academy at Kendal, he went to Manchester, where he supported himself all the rest of his life by teaching mathematics. Fortunately for science, a blind gentleman named Gough became interested in him, and gave him the use of his library and chemical laboratory, which enabled Dalton to work out many useful facts, and to establish the laws which are now the guide of all chemists, though they differ about some of his conclusions.

You will remember that it was only in the time of Lavoisier that chemists began to weigh carefully the gases

<sup>1</sup> Sir H. Davy was the first to discover, in 1807, that hydrochloric acid is made merely of hydrogen and chlorine; before then it was believed that every acid must have oxygen in it.

into which substances can be decomposed. Before then it had been thought sufficient to say that a substance contained sulphur, mercury, carbon, etc., without saying how much of it there was. But after the discovery of oxygen, when the real nature of chemical change began to be understood, chemists saw the importance of weighing accurately the different elements into which a substance can be broken up; and when this had been done for some time, and a great number of analyses had been made, it was seen that *any given chemical compound always contains the same elements combined in the same proportion.*

Thus, for example, all water, whether it comes from rain, snow, dew, steam, or exploded oxygen and hydrogen, will always be found to contain two parts by weight of hydrogen to sixteen parts by weight of oxygen; so that if you decompose 18 ounces of water you will collect

2 volumes of hydrogen weighing 1 oz. each	,	.	.	2 ozs.
1 volume of oxygen weighing 16 ozs.	.	.	.	16 ozs.
				18 ozs.

And this never varies. Again, if you take some ammonia and decompose 17 ounces of it you will collect

3 volumes of hydrogen weighing 1 oz. each	.	.	.	3 ozs.
1 volume of nitrogen weighing 14 oz.	.	.	.	14 ozs.
				17 ozs.

And this again never varies. Wherever you get ammonia it will always be made up of these proportionate weights of hydrogen and nitrogen.

This combination of the different elements in fixed quantities is called the *law of definite proportions*. It was hinted at by four chemists before Dalton; namely Proust, Wenzel, Higgins, and Richter, but it was very little under-

stood, and some eminent chemists, such as Berthollet, even doubted whether it was true. Dalton, however, made a remarkable discovery which both proved the truth of the law itself and showed that it meant a great deal more than had been imagined.

He found that not only are the elements in any one substance always in a fixed proportion, but that each element, such as oxygen, *has a weight of its own*, and will only combine with other elements in proportions of this fixed weight. For example, oxygen will join itself to nitrogen in five different proportions, making five different substances, and in each case the same fixed weight of oxygen is added. Thus, if you decompose 22.4 litres of

	Volumes of		Weighing	
	Nitrogen	Oxygen	Nitrogen	Oxygen
Nitrous oxide, you will get	2 . .	1 . .	28 grammes	16 grammes
Nitric oxide	2 . .	2 . .	28	32
Nitrous acid	2 . .	3 . .	28	48
Nitric peroxide	2 . .	4 . .	28	64
Nitric acid	2 . .	5 . .	28	80

So that each substance contains one more volume of oxygen compared to the nitrogen than the one before it; and this volume always weighs 16 grammes, while each volume of nitrogen weighs 14 grammes.

Oxygen behaves in this way in all compounds, only joining itself to other elements in weights of 16 or multiples of 16. Thus, if you heat mercury as Lavoisier did, so that it takes up oxygen out of the air, 200 parts by weight of mercury will combine with 16 of oxygen and no more. If you heat carbon with oxygen, 12 parts by weight of carbon will take up 16 of oxygen to make carbonic oxide, or twice 16 = 32 to make carbonic acid, but it will not take up anything between these weights. This same law holds true of

all the elements, each one having its own peculiar weight. Nitrogen, for example, combines in weights of 14, or twice 14 = 28, or three times 14 = 42, etc. ; sodium in weights of 23, 46, and 69, etc. This is called the *law of multiple proportions*, which we owe entirely to Dalton, and it is a fact about which all chemists agree. Dalton went on to try and explain it by a theory which is still a matter of speculation, and which some chemists do not receive.

**Dalton's Atomic Theory, 1808.**—In order to explain why each element should have its fixed weight in which it always combines, Dalton imagined, as Democritus, Epicurus, Bacon, and Newton had done before him, that all matter is composed of tiny parts, or *atoms*, which are too small to be seen, and which cannot be divided. These atoms, which he pictured to himself as round grains like very small shot, would be of the same size in every substance, but not of the same weight. Hydrogen atoms would be the lightest of all, for hydrogen is the lightest substance known ; oxygen atoms would be 16 times, and nitrogen 14 times, as heavy as those of hydrogen.

Now when two elements combine together they cannot take up less, according to Dalton, than one atom of each, or two atoms of one to one of the other, and so on, and therefore *exactly the weight* of an atom of any substance will always be added. For example, to turn back to our table on p. 389, Dalton would say that a *molecule*, or the smallest portion which can be imagined, of nitrous oxide will contain 2 atoms of nitrogen weighing 14 each to 1 atom of oxygen weighing 16 ; while nitric acid will contain 2 atoms of nitrogen = 28, and 5 atoms of oxygen,  $5 \times 16 = 80$ . If half an atom of oxygen could be added, then it might be possible to take up  $16 + 8$ , or 24 parts of oxygen ; but as the atoms are supposed to be indivisible, this cannot be done, but a

whole atom weighing 16 must be added each time. Therefore you will see that by an atom, Dalton meant *the smallest quantity of any element which can combine with other substances.*

Thus, water is made up of molecules, each containing two atoms of hydrogen and one of oxygen. But as these atoms cannot be seen, how can it be known how many there are in any substance, and when we have arrived at the smallest weight of any element? Dalton knew it in something like the following way:—

If you decompose water by electricity, you know that you will collect two bottles of hydrogen for one of oxygen. But you can also decompose it another way: if you take a small piece of the metal sodium and float it on water, it will roll round and round fizzing violently. This is because sodium joins very readily to oxygen, and the sodium is turning out some of the hydrogen from the water and taking its place. When the piece of sodium has disappeared, if you evaporate off the rest of the water, you will have a white powder, which is caustic soda; and if you decompose this soda, you will get out of it one measure of hydrogen, one of oxygen, and one of sodium. The sodium, you observe, has turned exactly half the hydrogen out of the water and taken its place; and this shows there must have been two atoms of hydrogen in the water, because a single atom could not have been divided.

In the soda we have now got the smallest quantity of each element—sodium, oxygen, and hydrogen—which will combine with any other. You can turn either of these three out of the soda, but you cannot turn out a part of any one of them. Therefore, a molecule of soda is said to be made of one atom of hydrogen weighing 1, one atom of oxygen weighing 16, one atom of sodium weighing 23, and

these numbers are called the atomic weights of hydrogen, oxygen, and sodium.

This will give you a rough idea of Dalton's theory of atoms. There is always this difficulty in it that we cannot be quite sure when we have arrived at the smallest quantity of any substance; for suppose that one day we were to find that half as much oxygen would unite with some other substance as now unites with sodium, then the atom of oxygen would no longer weigh 16. But if we bear this possibility in mind, then the theory is of great use in giving us the symbols which are now used in chemical language. For when it was once agreed that the weight of an atom of hydrogen should be reckoned as 1, then an atom of oxygen will weigh 16, and the letters HHO express a great deal. They tell us that two atoms of hydrogen weighing 2 are joined to one atom of oxygen weighing 16, to form a molecule of water. In the same way HO,NA<sup>1</sup> tells us that single atoms of each of these substances, weighing respectively, 1, 16, 23, form a molecule of soda. And thus a complete chemical language has sprung up, by which chemists in all parts of the world can understand at once what is the composition of any substance; and by means of these simple letters the most complicated chemical problems can be worked out clearly and intelligibly.

Dalton's theory was received very quickly by chemists, considering how entirely new the ideas were which it taught. His friend Dr. Thomson, an eminent chemist (born 1773, died 1852), gave a very clear account of it in his 'System of Chemistry,' and brought it under the notice of Davy and Faraday; and a great French chemist, Gay-Lussac (born 1778, died 1850), adopted it at once, and added another

<sup>1</sup> Na stands for Natrium, the Latin name for soda, now used for the metal sodium.

discovery in favour of it in 1809—namely, that when substances are reduced to gas, and the gas is collected, it is found that the different elements combine in equal or multiple volumes.

You will understand this by turning back to the compounds of nitrogen and oxygen (p. 389), where you will see that there was always either 1, 2, 3, 4, or 5 volumes of oxygen collected for one of nitrogen, and never a part of a volume. This was really a different fact from the one Dalton pointed out, that the elements combine in definite weights, and it was necessary to complete the law of multiple proportions. In 1811 a still further step in advance was made by the Italian chemist Avogadro, who showed that equal volumes of gases or vapours under the same conditions of pressure and temperature contain the same number of molecules; and Ampère brought forward the same doctrine in 1814. These discoveries were followed up by Gerhardt, Berzelius, Sainte-Claire, Deville, and others, and form the foundation of the chemical theory of the present day.

**Liebig the Great Teacher in the Chemistry of Organic Compounds.**—And now, before closing the history of chemistry, we must mention, in passing, one great division of the science of which we cannot attempt to give any real account—namely, the science of *organic chemistry*, or more properly the chemistry of organic compounds. This study began, as you will remember, when Boerhaave first examined the juices of plants and the fluids in animal bodies. But it can scarcely be said to have made any great advance till the year 1828, when a German chemist named Wöhler first showed that *urea*, a substance in the bodies of animals, can be made artificially. Since then Berthelot and other eminent chemists who have followed him have dis-

covered how to make many compounds in the laboratory which were before only found in living beings.

But the great master of organic chemistry whose name you must remember, though we can speak but little about him, was Baron Liebig, of Darmstadt, who was born in 1803, and died only a few years ago. From the days when he was a schoolboy, Liebig had made up his mind to be a chemist, and through the kindness of Humboldt he was fortunate enough to be introduced to Gay-Lussac and to work with him for some years. In 1824 he was made Professor of Chemistry at Giessen, where he organised the first great chemical laboratory, and for twenty-seven years lectured to students from all parts of the world. In 1852 he accepted an invitation to Munich, where he remained for the rest of his life. He was the first to analyse organic substances satisfactorily, by heating them in vessels with metallic oxides, thus reducing them to carbon and their other elements; and to show by experiments which he made with Wöhler, that there is chemically no sharp line of separation between organic and inorganic matter, for that, however complicated the components of organic substances may be, they are subject to the same chemical laws as the simpler components of inorganic matter. He is, however, perhaps best known for his great discoveries in agricultural chemistry. This subject, which was first treated by Sir H. Davy, teaches how the growth of plants depends upon the chemical state of the soil in which they are sown, how different crops should be sown in succession in any field so as not to exhaust the soil; and what manure will best give back to the ground the elements which the plants have taken out of it. Liebig also traced out the changes which food undergoes in our bodies, and studied which kinds turn to fat, muscle, blood, or sugar in our system. In 1832 he also discovered chloroform and



chlorale, though these were not used for producing unconsciousness till more than fifteen years later by Dr. Simpson.

The whole history of organic chemistry, however, is far beyond us at present; the science has only existed for the last fifty years, and the chemical substances which are created in a living body are extremely complicated, making the whole subject very difficult to understand. Moreover, we do not pretend to follow out the particulars of any science; if you can remember the names of some of the great pioneers of chemistry from the time of Geber in the ninth century up to the days of Davy, Faraday, and Liebig, and have some slight understanding of the nature of the work they did, you will have obtained no slight foundation for future work, and this is all we can attempt in a book of this kind.

---

*Chief Works consulted.*—Davy's 'Works,' 1840; Whewell's 'Inductive Sciences;' Dalton's 'Chemical Philosophy,' 1808; Dr. Henry's 'Memoir of Dalton,' 1854; Fownes's 'Chemistry;' Brande's 'Chemistry;' Faraday's 'Various Forces of Nature;' 'Edinburgh Review,' vol. xciv. 'Modern Chemistry;' Hoffmann, 'On Liebig and Faraday;' Liebig's Scientific Attainments, 'Contemporary Review,' April 1877.

## CHAPTER XXXVIII.

## SCIENCE OF THE NINETEENTH CENTURY (CONTINUED).

Jussieu on Natural System of Plants—Sprengel on Insect Fertilisation  
—Robert Brown—Goethe on Metamorphosis of Plants.

THE short sketch of advances in modern chemistry given in the last chapter brings us to the end of the physical sciences, or those which deal more particularly with the properties of inorganic substances, and the laws of their action upon each other. We must now pass on to those sciences which treat of the past and present history of the globe, and the living beings which inhabit it. I shall not attempt to speak of these sciences separately, for it is clearly impossible without a great deal of special knowledge to follow the modern discoveries in physiology, anatomy, medicine, zoology, botany, and geology.

All these sciences had advanced rapidly since the time of Haller and Hunter, Linnæus and Buffon. Famous anatomists and physiologists such as the two Monros, father and son, in England, Bichat (1771-1802) in France, Camper (1722-1789) and Blumenbach (1752-1840) in Germany, had been carrying on the study of the comparative structure of men and animals, and training up students to understand, far more completely than before, the functions of living beings. The followers of Linnæus, also, all over the world had been collecting and sending home for com-

parison rare plants and animals formerly unknown, which were eagerly studied for the new light they threw upon those which had been already dissected and described.

And so it came to pass that towards the end of the eighteenth century, men became eager not merely to examine separate specimens or structures, but to form theories about the living beings on the globe. They began to inquire why some animals should be so much alike in their general plan, and yet so different in their special characters; why the same part of the body should be made to serve for different purposes in different animals, instead of a special organ being provided; as, for example, the wing of the bat, which answers exactly to the front leg of a mouse, but is altered so as to be used for flying instead of walking. Then again, as the distribution of animals became better known, the question arose why certain kinds, such as kangaroos, should be found only in Australia, while they are wanting in all other parts of the world. Such general questions as these began to occupy the minds of naturalists, and we cannot close a history of science without trying to understand something of the attempts made to answer them.

**Natural System of Plants—Bernard and Antoine de Jussieu.**—Even while Linnæus was living, another botanist, Bernard de Jussieu (1699-1767), had begun to carry out his suggestion that plants should be classed by the agreement of all their observable characters, and not merely artificially by the number of their stamens. But Bernard did not publish his catalogue, and it was his nephew Antoine de Jussieu (1748-1836) who first published a book in which the plants were arranged according to the Natural System. It was Antoine who first sketched out roughly the characters of 'Families or Natural Orders' as we have them now. He made 100 families from the plants then known, and though

many more have been added since, yet a large number of those which he worked out have been permanently adopted. The Natural System obliges botanists to take into account every part of a plant before placing it into a family or order, and as it is often very difficult to determine which are the characters of most importance, there is a good deal of difference between the arrangements adopted by one botanist or by another. But though this is tiresome to pupils, it has been very useful in science, for it has served to bring out most clearly the way in which plants are related to each other, and the fact that in Nature there are not sharp distinctions between different kinds of plants, but that a particular species may be very closely allied in some of its characters to one family and in others to another, so that it is perhaps hardly too much to say that our great advance in botany in the present century has arisen from two things—(1) from the attempt to classify plants according to their natural affinities; and (2) from discoveries made with the microscope, begun, as we saw, p. 136, by Grew and Malpighi in the seventeenth century, and carried to perfection in our day.

The great Swiss botanist Auguste Pyrame de Candolle (1778-1841) did a great deal to spread the Natural System by adopting it in his works, and also by modifying it in many ways; and still further improvements have been made by the great Scotch botanist Robert Brown (1773-1858), and by Endlicher (1804-1849), and Lindley (1799-1865).

**Goethe's Theory of the Metamorphosis or Transformation of Plants, 1799.**—We have said that the study of the Natural System led botanists to observe more carefully the nature of plants and the manner in which they grow. One of the first men who threw any light upon the history of the growth of plants was the poet Goethe. Goethe

had a deep love of Nature, as may be seen in many of his beautiful minor poems, and this love led him in the year 1780 to devote himself to the study of the anatomy of plants and animals.

When he turned his attention to botany he was very much struck with the power which plants have of transforming or changing the growth of their parts. For example, the common wild rose in the hedges has a crown of pink petals, with stamens and carpels in the centre ; but the garden rose, which is nothing more than the wild rose grown in a better soil, has lost the stamens and pistils, or rather has changed them into flower-leaves, so that the whole flower is one mass of petals, and rarely forms any seeds.

It is clear, therefore, said Goethe, that the stamens and pistil of a plant are nothing more nor less than flower-leaves transformed into a peculiar shape, so that they serve to form seeds, and to carry on the life of the plant. And this is true of all the different parts of the plants. Wherever you look in the vegetable kingdom, you will find that every part of a plant is nothing more than stem or leaves altered in various ways to suit the work they have to do. Thus the stem of a geranium, the trunk of a tree, the twining stalk of the vine, the straw of wheat, the runners of a strawberry, and the fleshy potato, are all only different forms of stems and branches. Again, the two cotyledons of a seed which are well seen in the halves of a bean are but the first pair of leaves. From between them grows the stem, and out of this leaves of different forms, according to the peculiar species of plant.

Then, as the plant develops, come the buds of the flower, but these again are stems and leaves growing more thickly together, but altered and adapted to new functions. We find in different plants every variety of flower from mere

green leaf-like blossoms to the most gorgeous colours. The green leaves called sepals, which lie under the yellow petals in the buttercup, are transformed into brilliantly coloured petals in the tulip, while in some cases, such as occasionally in white clover, the whole flower, sepals, petals, pistil and stamens, has been known to be changed into little leaflets growing as if upon a branch.

For this reason gardeners find it possible to cultivate a plant so that it shall be all leaves and no flower, or, on the other hand, shall have a gorgeous flower while the leaves remain small and insignificant. And thus we are led to see that all the different parts of a plant are only peculiar transformations of simple stems and leaves.

This beautiful truth of the transformation or metamorphosis of plants we owe to the poet Goethe; for though Linnæus suggested it rather vaguely in some of his writings, and a botanist named Wolff seems also to have taught it in 1766, yet it was Goethe's essay on the 'Metamorphosis of Plants,' published in 1790, which first led naturalists to consider the question. Goethe's work was very little read at first, and he had great difficulty in finding a publisher for it, for it was thought that a poet could not know much of science; but Auguste de Candolle seeing what a new light Goethe's theory threw upon the study of plants, taught it in his works, and then it became gradually known as one of the greatest discoveries in modern botany.

**Fertilisation of Plants by Insects—Conrad Sprengel, 1750–1816.**—Another equally important fact was established at this time by the German botanist Sprengel, who was the first to notice the wonderful connection between plants and insects, which Darwin, Hermann Müller, and others have worked out so minutely.

Christian Conrad Sprengel was Head-Master at Spandau

in Brandenburg, but he became so wrapt up in his botanical studies that he was obliged to give up his office, and he lived in great poverty at Berlin, teaching languages and botany. He was so poor that he was not able to publish the second volume of his famous work on botany, and the publisher had not even given him a copy of the first volume for his own use. Sprengel tells us that in the summer of 1767 he noticed that in the flower of the *Geranium sylvaticum* the fine little glands containing honey at the base of the petals are protected by thick hairs, so that the rain and dew cannot reach them, just as our eyes are protected by our eyebrows and eyelashes from drops of perspiration creeping down the face; at the same time he observed that insects had no difficulty in passing through the hairs and sucking out the honey.

Again, he found that in the forget-me-not, the line of little spots in the corolla points directly to the place where the insects must go to get the nectar at the base of the flower. This proved, he thought, that there are special provisions in flowers to keep the honey for the insects, and to guide them to it. So far the flower was of use to the insect; the next point he discovered was that the insect in its turn benefits the flower. He observed that the *Willow Epilobium*, or Rose-bay, though it has its stamens and its seed-vessel both in one flower, cannot use the pollen from the stamens to fertilise the ovules in the seed-vessel, because the stamens have withered away and their pollen is gone, before the stigma or top of the seed-vessel is sticky and ready to receive it. How then do the seeds become fertilised? Sprengel watched carefully, and found that insects, in flying from flower to flower, brought the pollen-dust clinging to them from younger flowers in which the stamens were just ripe, and left it in the older flowers where the stigma was

ready to receive it. He afterwards found that in the cypress-spurge exactly the opposite takes place. In this plant the stigma is ready first, and the insects bring pollen from older flowers, and the seeds form in the young flower before its own stamens are ripe.

From these facts Sprengel came to the conclusion that it is an advantage to a flower to use other pollen than its own ; and that the colours and shape of the flowers, and the honey they secrete, are all adapted to attract the visits of insects for this purpose. He also pointed out that flowers which are not visited by insects are generally very insignificant, but that they have large quantities of pollen-dust, so that it may be carried by the wind.

Sprengel looked upon all these adaptations as produced at the creation of the plant or insect in order to secure that they should be useful to each other. But, as we shall see in Chapter XLII., there is now every reason to believe that they have been gradually perfected, by the flower adapting itself to the visits of some particular insect which can perform for it the work it needs.

**Structural and Physiological Botany — Robert Brown, 1773-1858.**—The beautiful study of the relation between insects and flowers is more easy to understand, but certainly not more important, than the investigations into the structure and life of plants which have been carried on in the present century. Ever since the time of Malpighi and Grew the improvement of microscopes and the examination of minute parts of plants had been progressing ; and Mirbel (1776-1854) in France, and Moldenhauer (1766-1827) in Germany, together with many others, had greatly added to our knowledge of the structure of the cells and tissues of plants, the growth of stems, and the formation of seeds. Grew had already pointed out in 1672 that the outer



coat of seeds has a little hole in it which he thought was for the purpose of letting the roots of the young plant grow out ; and Mirbel in 1815 showed that when a young ovule, such as you will find in the ovary of a flower bud, begins to grow it appears first as a little swelling made up of cells called the nucleus, growing on a short stalk, and that round this usually two coats gradually grow, one outside the other, while neither of them close quite round the nucleus but leave the opening which Grew had observed, and which had already been called the *micropyle*, "or little gate." It is, however, to the Scotch botanist, Robert Brown, that we owe the first complete explanation of the use of these different parts.

Robert Brown was the son of a minister at Montrose, and his first great step in botany was made when he went with Captain Flinders' expedition to Australia in 1801, and spent five months there, bringing back with him 4000 new species. He then became conservator to Sir J. Banks' museum ; and after the death of that eminent botanist he removed with the collection to the British Museum, where he received £350 a year, and a pension of £200 granted by Sir Robert Peel at Humboldt's request. A whole volume might be written of the additions which he made to botanical knowledge, but we must confine ourselves here to his work on seeds.

He established beyond a doubt that the *funicle*, or little stalk *f*, Fig. 72, by which the ovule is attached to the ovary, is the channel through which it takes in its nourishment ; and that the *micropyle*, *m*, is the place through which the pollen tube reaches the young ovule and forms a

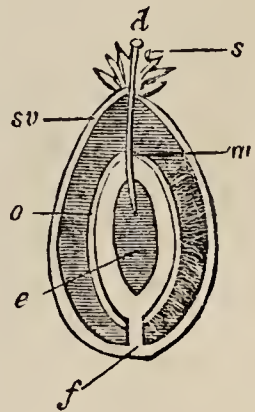

FIG. 27.  
Seed-vessel of nettle.  
*s*, Stigma ; *sv*, Covering of seed-vessel ; *o*, Ovule ; *e*, Embryo ; *f*, Funicle ; *m*, Micropyle ; *d*, Grain of pollen dust.

fertile seed. He pointed out that inside the nucleus of the ovule is a bag or *embryo-sac*, *e*, which has been formed out of one of the cells, and that when the pollen-dust *d* falls on the stigma of the pistil, it sends down a tube which creeps through the micropyle, and laying its extremity upon the embryo-sac causes the young plant to form in it. He also noticed that the root of the plantlet is always turned towards the micropyle, while the shoot or plumule is turned towards the funicle. It is easy to see this shoot by simply removing the brown seed-skin of an almond, and splitting it in half. The two halves are the two *cotyledons* or seed-leaves with the little bud or plumule lying concealed between them, the thickened end of it being the rootlet or radicle.

Robert Brown showed that we may learn a great deal

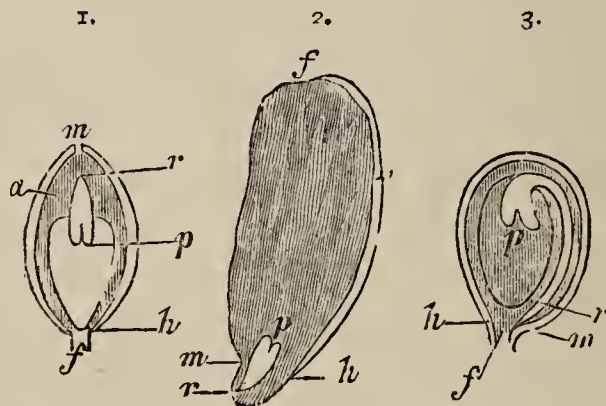

FIG. 73.

1. Nettle-seed cut in half; *a*, albumen in which the cotyledon or single seed leaf is imbedded.
  2. Almond-seed cut in half. } These two seeds have no albumen, the cotyledon fills
  3. Hemp-seed cut in half. } the whole of the seed-skin.
- f*, Funicle; *h*, Hilum, where the seed breaks off from funicle when ripe; *m*, Micropyle; *r*, Radicle, or young root; *p*, Plumule, or young leafy shoot.

about the relationship of plants by studying the way in which the embryo is placed. Nos. 1, 2, 3, Fig. 73, give three seeds, the nettle-seed, the almond-seed, and the hemp-seed. In the nettle-seed the embryo is upright, and the micropyle

is at the opposite end to the hilum, or place where the seed breaks off from the funicle. In the almond-seed, on the contrary, the embryo is turned upside down, or *inverted*; the micropyle is close to the hilum, while the funicle passes right round to the other end, carrying the nourishment, as before, opposite to the tip of the plumule. Lastly, the embryo in the hemp-seed is neither upright nor inverted, but *curled* round so that the micropyle and the funicle are both close together; and yet the rule is still observed, that the root should point to the micropyle and the plumule to the funicle. The study of the structure and position of the ovule are now of great use in classifying plants.

**Protoplasm**—Hugo von Mohl, 1805-1872.—The microscope had now revealed the history of some of the most delicate structures of plants, but one question remained unanswered, namely, What is the living active matter which forms the cells, the tissues, and the fibres? The answer to this question was found in the year 1853 by the German botanist, Hugo von Mohl, when he showed that the young cells of plants are filled with a thick semi-fluid substance full of innumerable white granules and that, as the cell expands, these granules flow in streams from the centre to the circumference of the cell in never-ceasing activity.

We find this semi-fluid living matter equally in the embryo-sac of the young ovule and in all the cells of a young plant; and from it is formed that inert or dead matter which composes the cell wall; and, because it is the simplest form of vitality known to us, and out of it all the life of the plant springs, Von Mohl called it *Protoplasm*, or the *first formative material*.

Chemists have now shown that this living active protoplasm is composed chiefly of the four elements—hydrogen, oxygen, nitrogen, and carbon, and plants have the power of

manufacturing it out of the non-living matter in the air and soil in which they grow. What this power is we do not know, and though the life in our own bodies and in that of all animals is supported by this same kind of living matter we cannot manufacture it; we, and all the animals can only obtain it by feeding on plants, or on other animals which are vegetable-feeders, and which therefore have had their food prepared for them.

**Geographical and Economic Botany — Sir W. Hooker, 1785-1865.** — Thus, by means of microscopic botany our knowledge of the life of plants has been increased enormously in the present century; but it would not be fair to close this subject without speaking of the equally great advances in the study of the distribution of plants over the globe, and of their use to man. As far as England is concerned we owe much on this account to Sir William Hooker (1785-1865), who spent his life and a large part of his private fortune in encouraging the collection of plants all over the world, and in founding the Museums and Herbarium of Kew Gardens. He also exerted his influence largely in persuading the Government, both here and in the Colonies, to publish the Floras of the different districts, so that we now have a fairly accurate account of the plants of all the English possessions, and of the special homes or habits of different species, and this work has been carried on most effectively by his son, the present Sir Joseph Hooker.

Any botanist who now wishes to study the history of plants has means placed at his disposal, for which Gesner, Grew, Malpighi, and Linnæus longed in vain, and new observations are being added daily which should tempt all young minds to learn something of a science at once so beautiful and so accessible to every one who cares to turn

---

his attention to it; and it is to be hoped that these facilities will lead to a much more general knowledge than exists at present, both as to the use of plants in our daily life, and of their wonderful beauty.

---

*Chief Works consulted.*—Goethe's 'Œuvres Scientifiques;' Faivre; Asa Gray's 'Botany;' 'Sachs Geschichte der Botanik;' Robert Brown's Works; Proc. Linnæan Soc. Obituary of Robert Brown; Von Mohl in Wagner's 'Handwörterbuch der Physiologie;' Huxley's 'Physical Basis of Life.'

## CHAPTER XXXIX.

## SCIENCE OF THE NINETEENTH CENTURY (CONTINUED).

Humboldt—Lamarck—Cuvier—Geoffroy St.-Hilaire—Comparative Anatomy—Development of Animals—‘Homology’—Cuvier’s ‘Règne Animal’; His Restoration of Fossil Animals—Von Baer on the study of Embryology.

**Alexander von Humboldt studies the Lines of Equal Heat over the Globe—Founds the Study of Physical Geography—Writes the ‘Cosmos,’ 1793-1859.**—While Goethe was studying plants at Weimar, and learning the secrets of Nature in the quiet of his own home, another man of whom we must now speak was planning to travel in distant countries, and to write a history, as far as he was able, of the work which Nature is doing all over the world.

Alexander von Humboldt, who forms a link between the science of the eighteenth and the nineteenth centuries, was born at Berlin in 1769, and was educated (together with his brother William, the great philosopher and politician) at the University of Göttingen. At the age of one-and-twenty he went to Freyberg, where he was a pupil of Werner. It was at this time, when he was only just of age, that he formed the plan in his mind of spending his life in studying the works of Nature, and writing a ‘grand and general view of the Universe.’

The first sketch of his book, which he called ‘Cosmos,’ or ‘The Universe,’ was written in 1793, when he was only twenty-four; and the last sheets were printed in 1859, when

he was ninety years of age. In the sixty-six years between these two dates he collected and published in popular language an immense number of facts about nature in all parts of the world.

His chief voyage was to America in 1799, when he spent six years in Mexico, and along the shores of the Orinoco in the Andes. Here he began one of his greatest undertakings, namely finding out the climate of different parts of the world, and tracing out *isothermal lines*, or lines of equal heat over the globe, showing what countries have the same average temperature, and explaining why some enjoy an almost equable climate all the year round, while others are very hot in summer and cold in winter. For example, he pointed out that Greenland is much colder than Lapland, even in places which are on the same line of latitude, because a cold current from the North Pole flows past Greenland, while the warm Gulf Stream crosses over from the Gulf of Mexico and washes the shores of Lapland. The importance of this study of variations of temperature was first pointed out by Humboldt, and it should be remembered as one of his most original investigations.

Again, in his long journeys through South America, he traced everywhere the different species of plants which grew at various heights, even up to 20,000 feet on the slopes of the Andes. This led him to try and find the reasons why certain plants are only to be found in certain areas, in the same way that Buffon had worked out the distribution of animals. When he returned to Paris in 1804 he had collected an immense number of facts as to the heights of mountains, the climate of countries, the minerals and metals found in them, the active and extinct volcanoes, the nature of the rocks and soils, the vegetation and the animals; and with the help of the best scientific men in Paris (each

undertaking his own special science) he published twenty-eight large volumes, which contained the conclusions based upon the facts he had learnt in his travels.

In 1827 he returned to Berlin, and was then invited by the Emperor of Russia to go on a journey into the Russian provinces of Asia, where he spent nine months making the same kind of observations that he had made in America. In 1830 he was sent to Paris as Prussian ambassador, and it was not till he returned to Berlin some years after, that he began to publish the 'Cosmos' he had been preparing for so long.

In this grand work he gives a complete history of astronomy, and all the discoveries in it made in his time; and then taking our own world as part of the universe, he describes the changes which are going on now, or have been going on in past times, on the face of the earth. It is to Humboldt that we owe much which makes geography interesting. The study of the surface of the globe, of mountain-chains, table-lands, and rivers, the climates of countries, the different winds which blow, and the currents which cross the ocean; the way in which plants and animals are distributed over the world; the different races of men, and how they have spread over the globe—all these and other facts which make geography something more than a mere list of names, Humboldt studied during his various journeys, and related them with a freshness which had a peculiar charm.

It was not so much that he advanced any one branch of science, as that he led men to look upon the earth and the universe as one vast whole, and to find a living interest in every part of it. In 1858 the last sheets of the 'Cosmos' were put into the publisher's hands, but Humboldt did not live to see them finished. He had done his part: the work



he had proposed to himself was completed, and he fell peacefully asleep on the 6th of May 1859.

**Lamarck—Cuvier—St.-Hilaire.**—When Humboldt visited Paris in 1804, there were three men holding professorships in the Museum of Natural History in that city, who had afterwards a great influence upon the study of the science of living beings. These three men were Lamarck, professor of zoology; Geoffroy St.-Hilaire, his fellow-professor; and Cuvier, assistant-professor of comparative anatomy.

The early part of the nineteenth century was, as you will remember, a very troubled time for France. The first Napoleon was carrying war and desolation all over Europe, and Paris was kept in a constant state of turmoil for many years. During all this time it is interesting to see how steadily and quietly the three men I have mentioned pursued their search after knowledge. Geoffroy St.-Hilaire twice risked his life in saving friends from the terrors of the Revolution; and Cuvier held political appointments both under Napoleon and under Louis Philippe; but in spite of these duties and interruptions their scientific work was never neglected; and a great part of the knowledge about plants and animals which we now possess was accumulated during the troublous times of the French revolutions.

Jean Baptiste de Monet, Chevalier de Lamarck, the elder of these three men, was born in 1744 at Bezantin, in Picardy, and a somewhat curious circumstance led him to devote his life to science. His father intended him for the church, but the lad had a passion for the army, and on his father's death, in 1760, set off to Germany, where the French were then fighting, and soon distinguished himself as a volunteer. Some time afterwards, however, one of his comrades lifted him up by his head in joke, and so strained the glands

of the neck that after a very severe illness he was obliged to give up his profession and become a banker's clerk in Paris. He had thus time and opportunity to study natural science, for which he had always had a great liking, and in 1778 he published a small book on botany. Buffon, who was then at the height of his fame, was pleased with this work, and procured for Lamarck an appointment in the botanical department of the Académie des Sciences. From thence he went to the Jardin des Plantes, and eventually became professor of geology in the Musée d'Histoire Naturelle.

George Leopold Cuvier, afterwards made baron Cuvier by Louis XVIII., was born of Swiss parents at Montbéliard, near Bésançon, in 1769. He, too, was intended for the church, because his parents were not rich and he had an uncle who could help him in that profession; but Prince Charles of Wurtemberg having heard of his abilities, sent for him and gave him a free education in the Académie Caroline at the University of Stuttgard. Here he already began in his spare moments to read books of natural history and to make drawings of plants and animals. When he left Stuttgard he went as tutor in a nobleman's family at Caen, in Normandy, and found a new and delightful study in the examination of the marine animals on the sea-shore. After living there six years, he happened to meet the celebrated Abbé Tessier, who had fled from the Revolution in Paris, and through his means the young Cuvier was introduced to Geoffroy St.-Hilaire and other scientific men in Paris, and became assistant-professor of comparative anatomy in the Jardin des Plantes. From this post he rose to very great honours both as an administrator and man of science, holding the posts of President of the Institute, Inspector-General of education, Councillor of the Imperial University, and many others of equal importance.

Geoffroy St.-Hilaire, the third and youngest of the three

friends, was born at Étampes in 1772. It is curious that he also began his education as a priest, and that all these three men should have given up the church for science. In St.-Hilaire's case it was a passionate love for zoology which led him to persuade his father to let him stop in Paris to study at the Jardin des Plantes, where he was soon offered a post which gave him an excuse for following his own tastes. He afterwards joined Lamarck at the Musée d'Histoire Naturelle in 1793; and in 1795 it was chiefly through his influence that Cuvier was invited to Paris and became their fellow-worker.

It now remains for us to see what was done by these three remarkable men. For three years they all remained at work in the museum. Cuvier had found in a lumber-room four or five old skeletons collected by Daubenton (see p. 204), and he determined to make them the beginning of a museum of comparative anatomy, which afterwards became very famous. St.-Hilaire worked with Cuvier, while Lamarck began the study of those animals—such as insects, snails, worms, shell-fish, sea-anemones, and sponges—which have no backbone, and to which he first gave the name of 'invertebrate animals.' Lamarck's work on these animals is one of the most famous he ever wrote.

In 1798 Cuvier and St.-Hilaire were both invited by Napoleon I. to go with the French army to Egypt and study the curiosities of natural history which were to be found there. Cuvier declined, but St.-Hilaire went, and spent three years examining the embalmed animals of the Egyptians. He succeeded in 1801 in bringing away a splendid collection of these and other relics from Alexandria when the French were forced to give up the town to the English. These collections were conveyed safely to the Museum in Paris in 1802.

**Lamarck on the Development of Animals, 1801.**—Meanwhile Lamarck published in 1801 a little work on the ‘Organisation of Living Bodies,’ and in it he first suggested that the different species of animals were not created separately, but had been gradually altered from a few simple living forms, so that, in the course of long ages, there had sprung up an immense variety of animals in the world. It must be remembered that Lamarck had chiefly studied plants and the lower animals. We have seen how Goethe showed that all plants are only altered stems and leaves: and the lower animals, such as jelly-fish, snails, and worms, differ much less from each other than the higher animals do. Therefore Lamarck was very much struck with the difficulty there was in settling which were distinct forms or species, and which might have come from the same parent, and he concluded that the only difference was that some had branched off from the common stock earlier than others, and so had become more unlike—just as brothers and sisters are very like each other, while distant cousins are much less liable to have the same features and expression.

The more we know of animals and plants, said Lamarck, the more difficult we find it to settle which are related to each other and which are not. Linnæus had long ago pointed out that among plants which are well known, such as the willows in Europe, the cactuses in South America, and the heaths and everlastings at the Cape, there are so many kinds differing very little from each other that it is impossible to say which ought to be considered as separate species and which as the descendants of one kind of plant.

Moreover, we know how much plants and animals are sometimes altered even in a few years. For example, by growing in a drier soil or up a high mountain, plants become stunted and altered in many ways, while birds when

shut up lose the power of using their wings, as has been the case with our domestic poultry. Man can make a number of different varieties both of plants and animals by merely keeping those which have the peculiarities he admires. The different kinds of pigeon, for example—the pouters, fan-tails, tumblers, and others, which are so unlike each other—are said by naturalists to be all descendants of the common rock-pigeon; and all the varieties of rabbit have come from one wild species. You cannot find a wild pigeon with a fan-tail, or a wild rabbit with lop-ears.

If man, then, in a few hundred years can make such changes, ‘is it not possible,’ said Lamarck, ‘that nature in all the long ages during which the world has existed may have produced the different kinds of plants and animals by gradually enlarging one part and diminishing another to suit the wants of each?’ These and many other arguments Lamarck brought forward in his work in 1801, and again in his ‘*Philosophie Zoologique*’ in 1809, to prove that the way in which the Creator has formed different plants and animals has been by altering them gradually out of simple forms.

There was, however, one very weak point in all his arguments; he did not show sufficiently what should cause living beings to go on altering, and becoming more and more different. For if you turn plants and animals, which man has altered, out into the fields again, in a very few generations they return very nearly to their old forms; nor can we see any reason why the differences between animals should go on increasing unless they were picked out and kept apart, as men keep them when they want to get new varieties.

Lamarck did, indeed, point out that climate and difference of food would help to alter the nature of an animal, but the chief reason he gave for changes taking place in them was that the animal itself might cause the alteration in

its form; as for instance, a giraffe constantly wishing to eat the boughs off high trees might stretch his neck, and so by degrees each generation might have longer necks than the last one. This reason was so weak and ridiculous that it prevented naturalists from paying much attention to Lamarck's theory.

**Geoffroy St.-Hilaire points out that the Parts or Organs are the same in all Animals, only Modified to suit their Wants.**—Geoffroy St.-Hilaire was, however, inclined to think that there was some truth in Lamarck's theory, although Cuvier was strongly against it. Cuvier, you remember, had given his time chiefly to the restoration of the skeletons of the higher animals, and he was as much struck with the immense difference between them as Lamarck had been with the likeness of the lower animals. Cuvier thought that each animal was at first created separately, and all its parts were arranged expressly to meet its wants. He looked upon the creation of each kind of animal as something similar to the making of a machine, into which we put a wheel here and a valve there expressly to make it do the work required.

Geoffroy St.-Hilaire, on the contrary, insisted that we never find any part of an animal which we can say was made expressly for it. Whenever we examine it closely enough we find it is exactly the same as exists in other beings, only its growth is altered so as to make it useful to that particular animal. The pouch of the Kangaroo, he said, is only a fold of the skin which is looser than in other animals; the trunk of the elephant is a nose which has become extremely long; the hand of a man, the leg of a horse, and the wing of a bat, are the same organ and have the same bones, although they serve such different purposes. 'Nature,' he said, 'has formed all living beings on one plan, essentially the same in principle, but varied in a thousand ways in all the minor

parts; all the differences are only a complication and modification of the same organs.'

This similarity of structure, or *homology* as it is called, which runs through all animals, was thus first clearly stated by St.-Hilaire, and it has now been most carefully worked out and confirmed by our living anatomists. Yet Cuvier opposed it to the last, for his mind was full, as we shall see presently, of another idea which is equally true; namely, how perfectly each part of an animal is made to fit all the other parts of his body; and it seemed to him impossible that this could be, unless each part was created expressly for the work it had to do.

The discussion between the two friends became so animated that all Europe was excited by it. It is said that Goethe, then an old man of eighty-one, meeting a friend, exclaimed, 'Well, what do you think of this great event? the volcano has burst forth, all is in flames.' His friend thought he spoke of the French Revolution of July 1830, which had just occurred, and he answered accordingly. 'You do not understand me,' said Goethe, 'I speak of the discussion between Cuvier and St.-Hilaire: the matter is of the highest importance. The method of looking at nature which St.-Hilaire has introduced can never now be lost sight of again.' And he was right, for the doctrine of homology, as taught by St.-Hilaire, is one of the strongest arguments for the theory of the development of living beings, now held by all the most able naturalists, and of which we shall speak in Chapter XLI.

**Cuvier proves that the Parts of an Animal agree so exactly that, from seeing one Fragment, the Whole can be known.**—We have seen that Cuvier did not agree with many of the views of Lamarck and St.-Hilaire. We must now consider what work he did himself; for though all the

three friends laboured well, Cuvier accomplished the most of all. He had a most remarkable capacity for work; we find him at the same time restoring skeletons and studying each bone with minute care, lecturing to large bodies of students, writing the history of all the sciences, and examining fossils from the rocks; besides presiding over councils and superintending national education. And whatever he touched was done thoroughly and with a master-hand.

His first great work was to collect all the different facts of comparative anatomy established since the time of Hunter, and, adding a great mass of his own observations, to build them up into one complete science of anatomy. In his 'Règne Animal,' published in 1817, he made a new classification of the whole animal kingdom, dividing them into four great branches. The *vertebrata*, or animals with back-bones; the *mollusca*, or soft-bodied animals, such as snails; the *articulata*, or animals, such as crabs, spiders, bees, and ants, whose bodies are composed of movable parts, hardest outside, and jointed or articulated together; and the *radiata*, or animals whose parts are arranged round an axis, such as star-fish and polyps. These four branches he divided again into classes, orders, families, genera, and species, making a much more complete classification than Linnæus had done, because it was founded more upon the internal structure of animals.

In this work he pointed out that the parts of an animal are made to fit to each other in such a wonderful manner, that if only a few bones are placed in the hands of an anatomist he ought to be able to tell you exactly what all the other bones must be. You will remember that Hunter had hinted at this when he showed how the teeth of each species of animal are fitted to the kind of stomach into



which the food is to pass. But Cuvier proved that this is true not only of the teeth but of every bone in the skeleton of an animal.

‘Every organised being,’ he says, ‘forms a whole and entire system . . . none of its parts can change without a change of the others also. Thus, if the stomach of an animal is made so as only to digest fresh flesh, his jaws must be formed to devour the prey, his claws to seize and tear it, his teeth to divide the flesh, and the whole system of his organs of motion to follow and overtake it. Nature must even have planted in his brain the necessary instinct to hide himself and lay snares for his victim. These are the general conditions of a carnivorous life, and all animals who are to live this life must fulfil them, otherwise they cannot exist. And besides these general conditions there are special ones, according to the particular kind of life the animal has to live, and each of these require modifications in the form of the organs; so that not only the class, but the order, the genus, and even the species of an animal are revealed by each part of it.’

And now you will understand why Cuvier could not believe St.-Hilaire’s theory that all the parts of one class of animals—such as the vertebrate animals, for example—are made on one model, and that when some organ has to play a different part it is altered, and not created for the purpose. Cuvier was strongly impressed with the beautiful agreement in every part of each particular animal, which enables it to provide for all its wants; while St.-Hilaire was equally impressed with the general agreement between the structure of all animals in any one great class. Both these views were true, but in the state of knowledge at that time it was very difficult to reconcile them. You must bear this in mind, because it is one of the difficulties upon which light is thrown

by Mr. Darwin's observations, which we shall examine by and by.

**Cuvier Studies and Restores the Remains of Fossil Animals, 1812.**—We have seen that Cuvier's knowledge of the agreement between the different parts of an animal was so great that from even *one bone* he could tell what the other parts of the body must be. The use which he made of this knowledge enabled him to reveal a wonderful history about the fossils buried in the crust of our earth.

When he first came to Paris, and for many years afterwards, a number of skeletons and parts of skeletons of animals were being dug up round about Paris. These were a great puzzle to anatomists, for the bones were many of them immensely large, and none of them seemed to agree exactly with those of any known animals. Cuvier no sooner heard of these fossils than he set to work to study them, making use of his great knowledge of anatomy to sort out the confused mass. His practised eye could detect from among a heap of bones those which belonged to each other, and out of a mere handful of fragments he could make an ideal restoration of the animal from which they must have come. It was like the work of an enchanter's wand.

'At the voice of comparative anatomy,' he writes, 'each bone, each fragment, regained its place. I cannot describe the pleasure I felt in finding that, as I discovered one character, all its consequences were gradually brought to light; the feet agreed with the history told by the teeth; the bones of the legs and thighs, and those parts which ought to unite them, agreed with each other. In a word, each one of the species sprang from its own fragments.'

And so month after month he worked on, and then to the great astonishment of naturalists he told them that all these animals were of species which are found nowhere

upon the earth now. *They were all extinct animals.* The greater part belonged to hoofed quadrupeds, something like our elephant, rhinoceros, and pig; then there was an elegant deer-like animal resembling a gazelle, some birds, some fish, and a kind of opossum, but all these were in some way different from any which live now.

Here was a history so strange that at first no one would believe it; for it meant that at the time when the land on which Paris now stands was being laid down by the rivers, there must have existed a whole group of animals, all of them more or less different from our present species of animals, which had not then begun to exist. It had long been known that strange shells were found buried in the earth's crust, but then naturalists could never be sure that some like them might not be living in other parts of the world without our knowing it, and they had always believed that at least the larger animals had been created quite recently at the same time as man. But here were animals which no one had ever seen upon the earth, and it was impossible to suppose that fifty different kinds of creatures of all sizes, some bigger than an elephant, could be roaming about the world unseen by any one. Therefore there could be no doubt that long before the time of history or tradition strange animals must have lived and died, and have been buried in the deposits now forming part of the earth's crust.

And when this was once recognised, and attention was called to these buried animals, little by little other forms were found in older rocks in different parts of the world, which appeared to be less and less like living animals the older the rocks were in which they were found. All these Cuvier described in his famous work called 'Les Ossemens Fossiles,' which he published in 1812, and in which he laid

before the world a startling history of the long succession of different animals which must have lived in past ages upon the earth.

And here we must close this very imperfect sketch of the work done by the three French naturalists. You ought chiefly to remember about them that Lamarck suggested that animals have been developed out of a few simple forms; that St-Hilaire proved that animals of one class are formed on the same general plan, similar parts being altered to serve different purposes in different animals; and that Cuvier showed that each part of an animal agrees with the rest so perfectly that from a few bones it is possible to tell exactly what animals had lived and died in past ages.

Geoffroy St.-Hilaire outlived both his friends, and died, blind and paralysed, in 1840. Lamarck had died in 1829, in his eighty-fifth year, having been blind for many years. Cuvier died on May 13, 1832. On the Tuesday previous he had begun his third course of lectures on Natural Science at the Collège de France, and had promised to give in that course his idea of creation, and how the Divine Intelligence is to be traced through all the operations of nature; but the promise remained unfulfilled; that same evening paralysis set in, and on the next Sunday he died in his arm-chair as if he had fallen asleep. He had begged to be buried privately, but that was impossible; on hearing of his death men of science flocked from all parts to do him the last honour, and his pupils bore him to the grave.

**Von Baer, the Founder of the Study of Embryology, 1828.**—We must not leave this question of the structure of animals without noticing in passing a new and important study which began about this time. This was the study of embryology, or of animals in the earliest stages of their life, as in the case of the chicken before it leaves the egg. You

know that if you take a bird's egg when it is newly laid, you will see inside it a yellow yolk floating in a white fluid. But if you take the egg after the mother-bird has sat upon it for some days, the yolk will begin to have the form of a bird, and if you were to go on taking an egg every day from under a sitting hen each one would be found, when opened, to be more like a chicken than the one before it, until the last, if you opened it just about the time when it ought to be hatched, would be a perfect chicken, only that its feathers would not be yet grown. Now the study of the different stages of the development of the chicken in the egg, and of all living beings going through the same stages, is called *Embryology*, and has become of immense importance in the history of animals.

You will remember that Harvey, Malpighi, and many other physiologists, occupied themselves with this study; but no discoveries of very great importance were made in it before the time of Karl von Baer, a Russian anatomist, who was born in 1792 and died in 1876. Von Baer was the pupil of a very famous anatomist, Professor Döllinger, and while he was working under him at Würzburg he made for him a number of observations upon the growth of the chicken in the egg, which led him to study the embryology of animals, and to discover the remarkable law of which we must now speak.

Before Von Baer's time it had always been supposed that the many kinds of animals, so different from each other, must be quite unlike from the very first moment that they began to grow, but Von Baer discovered that this is not so, but that the embryos or beginnings of an ox, a bird, a lizard, or a fish, are so like each other that they can only be distinguished by their size; and, what is still more remarkable, they remain alike till they have been growing for some time.

For example, if you could watch the beginning of these four animals, there would be a certain time during which you could see no difference in their form. Then after a while the fish would start off on a road of its own, but still the other three would go on all alike. Then, when they had grown a little bigger, the lizard would branch off, and only the bird and the ox would continue to have the same form, until lastly the bird would take on its own peculiar shape, and the ox would go on alone, having passed through the same stages as the fish, the reptile, and the bird, before it began to shape itself like a mammal. You must notice carefully that this does not mean that the beginning of an ox is at any time like a full-grown fish, which is a mistake that people often make; but only that there is a time when the *minute embryos* of these animals are almost indistinguishable the one from the other.

You will see, if you consider for a moment, that the discovery of this curious fact gave naturalists a new and much more perfect way of classifying animals; for they could actually read the history of an animal by watching it in the earlier stages of its growth and seeing at what point it branched off and put on special peculiarities of its own; and in some of the lower and more obscure animals several mistakes of classification were corrected by this means. There was also another very important question settled by Von Baer's law. It proved that St.-Hilaire was certainly right in saying that animals are formed on one plan, having special parts altered to suit their wants, for here in the embryo those parts can be seen actually developing differently in different animals out of the same beginnings. The study of embryology has been carried to great perfection since Von Baer published his 'History of the Development of Animals' in

1828, and among others two English names will be remembered in ages to come.

The first of these is Professor Kitchen Parker, who, deeply impressed with the truth of the evolution of animal life, has spent more than thirty years in dissecting the embryos of all classes of vertebrate animals. By this means he is tracing out the hidden links of structure between widely separated orders, and though the many proofs of wide-spreading relationship which he detects are far too intricate and involved to be shortly explained, yet he is slowly but surely demonstrating, from embryos often not half an inch long, the stages through which fish and reptile, bird and beast, have passed in ancient times to their present widely varied forms.

The other name is that of Francis Balfour, born 1850, who died by a fatal slip on Mont Blanc in 1882. In a short life of thirty-two years Balfour not only became the first authority in the world on embryology, but by his enthusiasm he drew around him at Cambridge more than eighty students for the study of his favourite pursuit, and founded a school of 'Morphology,' which bade fair to be a new starting-point in science. His untimely death has left to the pupils who adored him the sad but grateful task of carrying on the work he began so well.

---

*Chief Works consulted.*—L. Agassiz's 'Centenary Address on A. von Humboldt,' 1869; Humboldt's 'Cosmos;' Lamarck's 'Philosophie Zoologique;' Cuvier's 'Ossemens Fossiles;' Geoffroy St.-Hilaire's 'Zoologie Générale Suites à Buffon;' 'Vie et Travaux de G. St.-Hilaire;' Flourens' 'Eloge de Cuvier;' Lauder's 'Memoir of Cuvier;' 'Memoir of Lamarck;' Huxley on Von Baer—Appendix to Baden Powell's 'Unity of Worlds.'

## CHAPTER XL.

## SCIENCE OF THE NINETEENTH CENTURY (CONTINUED).

Prejudices which retarded the Study of Geology—Lyell, ‘Principles of Geology’—Murchison—Louis Agassiz—Glacial Period—MacEnery—Boucher de Perthes—Flint Implements—‘Antiquity of Man’—Swiss Lake-dwellings.

IN 1811, when Cuvier published his work on ‘Fossil Remains,’ William Smith, who, as you remember (p. 221), first studied the rocks of England, had nearly completed his geological map, and scientific men were beginning, both in England and Germany, to understand something of the different ages of the formations which have been laid down from time to time on the surface of the globe; yet still they were prevented from reading the past history of the world rightly, by several false notions which continued to prevail.

People had so long held the belief that our earth had only existed a few thousand years, that when geologists began to find great numbers of strange plants and animals buried in the earth’s crust, immense thicknesses of rock laid down by water, and whole mountain-masses which must have been poured out by volcanoes, they could not believe that this had been done gradually and only in parts of the world at a time, as the Nile and the Ganges are now carrying down earth to the sea, and Vesuvius, Etna, and Hecla are pouring out lava a few feet thick every year. They still imagined that in past ages there must have been mighty



convulsions from time to time, vast floods swallowing up plants and animals several times since the world was made, violent earthquakes and outbursts from volcanoes shaking the whole of Europe, forcing up mountains, and breaking open valleys. It seemed to them that in those times when the face of the earth was carved out into mountains and valleys, tablelands and deserts, and when the rocks were broken, tilted up, and bent, things must have been very different from what they are now. And so they made imaginary pictures of how Nature had worked, instead of reasoning from what they could see happening around them.

**Sir Charles Lyell teaches that the Rocks of our Earth have been formed by Natural Causes, such as are still going on, 1830.**—The man who first broke through these prejudices was our great geologist, Sir Charles Lyell. Charles Lyell was born in Forfarshire in 1797, the same year that Hutton died. From his earliest childhood he had a great love of Natural History and Science, but as his father wished him to become a barrister, he went to Oxford to follow the usual course. There he attended the lectures of Dr. Buckland, the great geologist of that day, and this decided him to devote his life to the study of geology. He began first by examining the formations round about his own home in Forfarshire, and he soon became convinced, as Hutton had been before him (see p. 218), that we can only learn the past history of the earth by observing the causes now at work.

What Hutton had suggested Lyell worked out. He collected with great care all that is known of changes going on now all over the world, and the causes which produce them. Among these were—

1stly. The fall of rain, and how it wears away the earth and carries it off in little rills to the river.

2dly. The amount of mud carried by mighty streams, such as the Ganges, the Nile, and the Mississippi, and laid down in the sea at their mouths.

3dly. The amount of lime, iron, and other minerals brought up by springs from the inside of the earth, and thrown down on the surface.

4thly. The tides and currents of the sea, and how they wash up fresh land on some coasts and eat away the land on others.

5thly. The growth of corals in the sea, and how remains of their skeletons become cemented into limestone.

6thly. The volcanoes which are throwing out lava, and how much they have thrown out in historical times.

7thly. The different earthquakes which man has witnessed, how they have broken and dislocated the land, raising it in some places, as in New Zealand, and causing it to sink in others, as at New Madrid, in America.

8thly. The way in which plants and animals are buried in the mud of lakes, or at the mouths of rivers, or in peat and sand.

All these and many other changes which are taking place all over the world in the present day, Lyell studied with great accuracy, and then began to accumulate all this evidence in a work showing that what we find in the rocks might all have been produced by such causes as these, without imagining any extraordinary violence of nature.

While writing this book he went with another celebrated geologist, Murchison, to Italy and Sicily, and there he studied not only the rocks which the volcanoes of Vesuvius and Etna have been building up for ages, but also saw at Syracuse and other places enormous beds of limestone filled with shells of kinds which may still be found living. The immense thickness of these limestone beds, amounting

in some places to 700 and 800 feet, astonished him greatly. He knew they must all have been formed slowly beneath the sea, out of the remains of corals and other animals, whose skeletons or shells are composed of lime, and that they must afterwards have been raised up to the height of 3000 feet above the sea, at which he found them; and when he thought of the time which this must have taken, and remembered that it had all happened since the other great masses of rocks below, containing extinct shells, had been formed, he felt more than ever convinced that the world must be very old to have allowed time for all the wonderful changes that have taken place.

In 1830 his book was published, and though it met with great opposition because men's minds were prejudiced the other way, yet his facts could not be denied. He showed, for example, on the one hand that the river Ganges in India carries down every year, and deposits in the sea, as much mud as would make sixty of the great pyramids of Egypt, and which if it was brought in ships would require 2000 full-sized merchant vessels laden with mud to sail down the Ganges every day. Here, then, was an example of rocks being now laid down in the sea, not by violent floods and sudden catastrophes, but so quietly that no one even notices that nature is at work.

Then, on the other hand, he pointed out how in our own little island, on the coasts of Yorkshire and Norfolk, the sea eats away the cliffs, so that towns such as Auburn, Hartburn, and Hyde in Yorkshire, which are marked upon old maps, have been entirely washed away, and the ground on which they stood has been spread out on the bottom of the ocean; and yet this is done so gradually, year by year, that new towns of the same name are built up farther inland, and no one disturbs themselves about the loss.

Then to account for the huge masses of basalt and lava which are found in the earth's crust, he reminded his readers of the great eruption of the volcano called Skaptar Jokul in Iceland, which took place in 1783. In this eruption the torrent of lava was ninety miles in length, from seven to fifteen miles in breadth, and in some places 600 feet deep, and the whole mass poured out would have made a mountain as big as Mont Blanc.

He then went on to give accounts of the remarkable earthquakes which have taken place in times of history: the earthquakes in India, in Java, and especially in Calabria, in 1783, when new lakes were formed by the sinking in of the ground, and the rivers were made to run in new channels. He showed also how the height of land is sometimes changed in volcanic countries; as on the coast of Italy, near Naples, where the ground on which the famous Temple of Serapis stands can be proved to have been raised and depressed twice even in historical times.

And besides all these obvious changes which men cannot help noticing, he proved that other quiet and unnoticed risings and fallings of land are taking place; as, for example, in Norway and Sweden, where the land is rising out of the sea in some places at the rate of about two or three feet in a century; and in Greenland, where it is sinking, so that huts built near the shore have to be moved inland, because they are becoming submerged in the sea.

These are a very few of the facts which you can understand, by which Lyell demonstrated that the surface of our earth is always undergoing changes in our own day, and that by similar changes going on in past times the whole of the crust of our earth may have been built up and carved out. In addition to this he showed how plants and animals are now being buried in mud and earth, and how their remains

are washed into caves, or preserved in peat-mosses; thus affording us examples of the way in which the remains of ancient animals have become entombed in the earth's crust.

Thus Sir Charles Lyell taught men to read the true history of the earth. It is difficult in the present day to understand rightly how great a work he accomplished, for though his ideas were ridiculed in the beginning, yet he lived long enough to see all men agree with him, and his doctrines received as evident truths. Like all other great men, he was humble and reverent in his study of nature. His one great desire was to arrive at truth, and by his conscientious and dispassionate writings he did much to persuade people to study geology calmly and wisely, instead of mixing it up with angry disputes, like those which, in the time of Galileo, disfigured astronomy. He travelled a great deal, especially in America, and worked out a great many facts in geology. But in future ages his name will stand out among those of other geologists chiefly as having shown that *the changes in the crust of our earth have been brought about in the course of long ages by causes like those which are still in action.*

After the year 1830, when his 'Principles of Geology' was first published, the study of this science went on very rapidly indeed. A few years before, Sir Roderick Murchison (1792-1871) and Professor Sedgwick (1787-1873) had begun to map out the early formations in Wales with the same accuracy that William Smith had employed in England, and from this time Murchison continued for many years to unfold the history of the Silurian rocks in Wales and England, the Permian rocks in Russia and the 'Fundamental gneiss' or earliest known rocks in Scotland. On the Continent also and in America, surveys began to be established to map out the ground and ascertain the position and age of the various

formations. As with all the other sciences of the nineteenth century, you must read the details of these advances in geology in special works; but there are two great discoveries which we must mention very shortly here. These are—1st. The fact that much of temperate Europe, Asia, and America was at one time covered with ice, as Greenland is now; and 2d, that man has lived upon the earth much longer than was once supposed.

**Louis Agassiz, 1807-1874.**—The man whose name will always be remembered as having first traced out the wonderful history of the great ice-period is Agassiz, the famous Swiss naturalist, who was born in 1807 at Mottier, near Neuchatel, and died in 1874 in America.

Louis Agassiz was the son of a Swiss pastor, and he forms one among many bright examples in the history of science, of men who cared neither for wealth, advancement, nor ease, but for the study of nature alone, and the grand truths to be obtained by it. After receiving a good education in the Swiss and German Universities, living frugally and economically, as students can on the Continent, he took his degree of Doctor of Medicine at Munich in 1829, having already written several important papers on zoology. In 1832 he was made Professor of Natural History at the University of Neuchatel; and in 1833 he published his work on 'Fossil Fishes,' the expenses of the book being liberally paid by Humboldt. In 1839 he published his grand work on the 'Fresh-Water Fishes of Europe,' which cost him so much that he was very poor for years afterwards.

There are very touching passages in some of Agassiz's private letters at this early period, when he had a hard struggle with life. His enthusiasm breathes out so naturally, and he speaks so regretfully of want of money, not

for himself, but for the work he longed to complete ; while his gratitude is so sensible and heartfelt towards those who helped him to bring out his splendid additions to the science of zoology. His was a warm-hearted, earnest, and active nature, and he was beloved by all who knew him. It is pleasant to think that the Americans, among whom he spent the latter half of his life, from 1846 to 1874, appreciated him fully. In 1867, by the kindness of Mr. Thayer, he was able to make a most important journey of discovery in Brazil ; and up to the last years of his life he continued to train up young naturalists to carry on his favourite studies.

**Agassiz proves that parts of modern Europe and North America must once have been covered with Great Fields of Ice, 1840.**—It is, however, of the early part of Agassiz's life, while he was still in Switzerland, that we must now speak. Although his chief study was zoology, yet he could not live at Neuchatel, and travel about the Alps, without being struck with those mighty *rivers of ice*, called *glaciers*, which creep slowly down the valley of the Alps in Switzerland, carrying with them stones and rubbish. (See Fig. 74, p. 434.)

These glaciers are formed by the snow, which collects on the tops of high mountains, and sliding down, becomes pressed more and more firmly together as it descends into the valleys, until it is moulded into solid ice, creeping slowly onwards between the mountains, and carrying with it sand, stones, and often huge pieces of rock which fall upon it. At last one end of this ice-river reaches a point where the air is warm enough to melt it, and here it flows gradually away as water, leaving the stones and rubbish it has brought down lying in a confused heap, which is called a *moraine*.

Towards the end of the eighteenth century a famous

geologist, named De Saussure, spent much time in examining the glaciers of the Alps, and pointed out how they are now forming large deposits in the valleys out of these heaps of rubbish which they bring down from the mountains. Since his time many geologists had taken up the study, but it was



FIG. 74.

Glacier carrying down Stones and Rubbish (Lyell).

Professor Agassiz who first spelled out the wonderful history we can learn from it, about the former climate of our hemisphere. He noticed that rocks over which a glacier has moved are polished and grooved by the rough stones and sand frozen into the bottom of the ice, just in the same way as a piece of wood is scraped by the sharp iron at the bottom of a plane; and by these glacial scratches or *striae*,



as they are called, he could tell where glaciers had been, even though there was nothing else to show that ice had ever existed in the country.

Now, when he began to examine the slopes of the Alps many hundred feet above the present glaciers, and also in places where it is now too hot for ice to remain, he found to his surprise numbers of these glacial striæ and also remains of huge moraines, showing that the glaciers of olden time must once have been much larger and have stretched farther down the valley than they do now. And what was still more strange, these same marks were to be seen on the Jura Mountains, on the other side of Switzerland, where there are never any glaciers at present ; moreover, on the Jura there were found huge blocks, some of them as big as cottages, which were not made of the same materials as the hills on which they rested, but were broken pieces of rock such as are now only found on the Alps.

It was clear, then, that these enormous pieces of stone must have been carried right across Switzerland from the Alps near Mont Blanc, and across the lake of Geneva, which is 1000 feet deep, and then deposited on the Jura range near Neuchatel, where one block of Alpine gneiss, called the *Pierre-à-Bot*, as large as a good-sized cottage, sits perched on a mountain 600 feet above the top of the lake. How had these blocks travelled across the Swiss plains? No flood could have carried them, for they were too heavy, and besides they were not smooth as stones are which have been rolled in water, but were rough with sharp edges. Agassiz was convinced, therefore, that they must have been carried by ice, and that huge glaciers must once have come down from the high Alps right across Switzerland, filling the lake of Geneva with ice, and carrying these blocks with them, as modern glaciers do now in the Swiss valleys.

This was a marvellous history, for it showed that all the lower land of Switzerland must once have been buried in ice, but other facts afterwards came to light which were more wonderful still. In 1840 Professor Agassiz came over to visit Great Britain, and when he went to Scotland with Dr. Buckland his practised eye discovered at once in the Highlands glacial scratchings, remains of moraines, and blocks which had been carried by ice; and soon it became evident that these were not confined to Scotland, for Dr. Buckland recognised them again in Wales and the North of England, where moraines and erratic blocks are to be seen in all parts of the country. So that here, too, in our little island, there must have been at one time huge glaciers as large as those now found in the Alps.

Nor was this all; for when once geologists knew where to look for these signs of glaciers, it began to be discovered little by little that parts of all the northern countries of Europe, Norway, Sweden, Russia, Germany, Switzerland, Northern Italy, England, and even on the other side of the Atlantic, Canada and North America, have been smoothed and scratched; and huge erratic (or wandering) blocks have been scattered over them, showing that in very remote ages (yet still while very nearly the same kinds of plants and animals as now were living upon the globe), the temperate parts of our northern hemisphere must have been intensely cold, causing a large part of these countries to be covered with great fields of ice, as Greenland is in the present day. And just as we see now that icebergs break off from the Greenland glaciers, carrying with them stones and mud, and dropping them at the bottom of the sea; so in those times icebergs floated over many of the valleys of Europe, which were then submerged beneath the ocean. You may see in the railway-cuttings of Wales, and in the sea-cliffs in the

coast of Yorkshire and Norfolk, huge masses of *glacial drift*, as it is called, made of mud and stones confusedly mixed together, which were dropped from icebergs travelling southwards from the ice-fields.

This period of cold is called by geologists the 'Glacial Period;' and when you read works on geology you will see that it explains in a wonderful manner many curious facts in the later history of our earth, and the distribution of plants and animals upon it. For the present it is enough for you to remember that Agassiz first pointed out the signs of this cold period, and that this discovery was one of the earliest rewards of a patient study of causes which are going on now; for it is from the ice-action in Switzerland and Greenland in the present day that we are able to understand how these huge ice-fields carried down erratic blocks and the mud of moraines during the Glacial Period.

**Geological Proofs that Man lived upon the Earth in Ages long gone by, with Animals which are now extinct, 1847.**—The second remarkable discovery which has been made in geology in this century is that of the antiquity of man; or the fact that man must have existed upon our earth long before the very earliest times of history or tradition, in an age when an elephant and a hyæna, of extinct species, roamed about England and France, together with some other strange animals which are not now to be found upon the globe.

This discovery, which was not believed for a long time, was first announced by a French geologist, M. Boucher de Perthes, in the year 1847. It happened that near this gentleman's house, at Abbeville in Picardy, gravel-pits had been dug from time to time for repairing the fortifications of the town, or mending the roads. During these excavations, in the beginning of the century, a great many bones

of animals had been dug up and sent to Cuvier at Paris; and he stated that some of them belonged to animals slightly different from any now living, though not so ancient as those which came from under Paris (see p. 420). This showed that these beds of gravel must have been formed long before the times of history or the earliest ages in which man was supposed to have been upon the earth. People, therefore, were much astonished when M. Boucher de Perthes stated in 1847 that he had found very rough stone weapons in these beds, such as savages might use, seeming to prove that men must have been living at the same time as these extinct animals.

This seemed so incredible that scientific men would not even listen to Boucher de Perthes' arguments in his work called 'Antiquités Celtiques,' and it was not till 1858, when one of our best living geologists, Mr. Prestwich, went to Abbeville and took a well-shaped flint hatchet out of the undisturbed gravel with his own hands, that people began to think that human beings must have been living in the world much longer than had hitherto been believed. When, however, this was once acknowledged to be true, several new facts sprang up to confirm the theory. Many years before, in 1825, a Roman Catholic priest, the Rev. J. MacEnery, had found flint tools, with the bones of the extinct elephant, hyæna, and bear, in a cave called Kent's Hole, near Torquay, but very little notice had been taken of this discovery. Now, however, they were thoroughly studied, and they showed clearly that men who made rough flint tools (such as are still made by savages in many parts of the world) must have lived in England, together with a bear, an elephant, a lion, and a hyæna, all of species which have now ceased to exist.

**Discovery of the Swiss-Lake dwellings, 1853.—**

Again, in Switzerland, most curious discoveries have been made, giving us proofs of three distinct periods in the life of mankind. In the year 1853, when the Swiss lakes were very low in consequence of a long drought, wooden piles were observed to rise above the water; and when these were examined by the Swiss antiquarians, it was found that they were foundations of wooden villages, which had been built by the inhabitants of Switzerland in past ages. They stood some way out in the lake, and must have been joined to the shore by wooden bridges which the villagers could lift up when enemies came to attack them, and thus become protected by the water surrounding them. Habitations of this kind are built in the present day by the natives of Papua or New Guinea.

Down below the piles in the mud of the Swiss lakes a great number of tools, cooking utensils, bones of animals, and even burnt bread and corn, were found; and the remarkable thing was, that the different kinds of tools showed that the villages did not all belong to one age. In a few, on the lakes of Bienne and Neuchatel, *iron* tools were buried, showing that when these villages were inhabited men knew how to melt iron out of the rocks and make it into tools. These villages must have been about the time of the Romans.

In others, however, only *bronze* tools were found, and these were much older, because bronze was used long before iron was discovered. And lastly in some, tools of *stone* only have been found, some beautifully polished, but others rough and rude, showing that the men who used them must have been mere savages like the Australians now; and yet the oldest of these lake-villages have no bones of extinct animals in them, and therefore cannot be so ancient as those men whose tools were found in the cavern at Torquay and the sandpits of Abbeville, or as have since been found in

England, Denmark, Germany, America, and indeed in almost all countries.

It is impossible, without a knowledge of geology, to realise how very long ago these last-mentioned men must have lived. But when I tell you that since their tools were buried in the rocks, there has been time for beds of immense thickness to be laid down little by little, as the Ganges is laying them down now; for parts of the French valleys to be gradually washed away, and their shape altered; for rivers to change their courses, and vast beds of peat to grow over the bottoms of the valleys; and, more than all, for whole races of animals which once lived to have died quite away from the face of the earth, you may perhaps form some idea of the long ages that man must have been upon our globe. This history, however, is so new and as yet so little understood, that it cannot be explained in a few pages. You will find all the proofs of it given in Sir Charles Lyell's work on the 'Antiquity of Man,' in which they were first collected in 1863; and you must remember the fact, that man is very ancient, as one of the great discoveries of the nineteenth century.

---

*Chief Works consulted.*—Lyell's 'Principles of Geology,' 'Elements of Geology,' 'Antiquity of Man;' Lubbock's 'Prehistoric Times;' 'Quarterly Geological Journal,' vol. xxx. : Obituary of Agassiz.

## CHAPTER XLI.

## SCIENCE OF THE NINETEENTH CENTURY (CONTINUED).

Facts which led Naturalists to believe that the Different Kinds of Animals are descended from Common Ancestors—Darwin—Wallace—Theory of Natural Selection—Selection of Animals by Men—Selection by Natural Causes—Difficulties in Natural History which are explained by this Theory—Foolish Prejudices against it.

**Facts which have led Naturalists to believe that the different kinds of Animals are descended from common Ancestors.**—We now come to the first attempt of any value which has ever been made, to explain how the different kinds of animals and plants have been produced. This question is so very difficult, and seems so much beyond our grasp, that we find very few people throughout the history of science who even tried to answer it. Aristotle, it is true, remarked that we can trace such a close resemblance between the different species, from the lowest plant up to the highest animal, as would seem to show they are related to each other (p. 16). Bonnet, too, thought that animals were developed from lower into higher forms (p. 202); and Lamarck, as we have seen, boldly suggested the same explanation (p. 414).

But people in general treated these as mere wild speculations, and were content to say that God had created animals just in the same way as they said that the stars

were created by Him, without pausing to consider *how* He has created them.

Since the time of Buffon and Linnæus, however, many new facts had gradually been brought to light about living animals ; and fossil species had been dug out of the earth, showing that many different forms had lived upon our globe, one after the other ; and these new discoveries led naturalists to speculate whether some clue might not be found to explain this long succession of living beings.

Then again, as naturalists spread all over the world and many new forms of animals and plants became known, it was found to be more and more difficult to separate the different species and to say which are and which are not descendants of one parent. Linnæus, as we have seen (p. 208), pointed this out in the case of plants, and wild roses are a very good example of it ; for the different kinds run so much into each other, that while one of our best botanists has divided them into *seventeen species*, another thinks that many of these must have come from the same parent, and that only *five species* can be distinguished. Again, among insects, the well-known naturalist, Mr. Bates, has shown us that on the Amazons in South America it is often impossible to tell, among some families of butterflies, which are the same species and which keep apart from each other. Facts like these, of the relationship of living beings, had long been forcing themselves upon naturalists, and this was one of the reasons given by Lamarck for supposing animals to be all descended from a few simple forms.

Another reason was that curious agreement in the bones of different animals which had become more and more noticed ever since the time of John Hunter, and which Geoffroy St.-Hilaire insisted upon so strongly. Why should



the animals of one class (such as the vertebrate or back-boned class) be formed all on one plan even to the most minute bones ; so that the wing of a bat, the front leg of a horse, the hand of a man, and the paddle of a porpoise, are all made of the same bones, which have either grown together, or lengthened and spread apart, according to the purpose they serve? And, more curious still, why should some animals have parts which are of no use to them, but only seem to be there because other animals of the same class also have them. Thus the whale has teeth like the other mammalia, but they never pierce through the gum ; and the boa-constrictor has the beginnings of hind legs hidden under its skin, though they never grow out. Here again it seemed extraordinary, if a boa-constrictor and a whale were created separately, that they should be made with organs which are quite useless ; while, on the other hand, if they were descended from the same ancestor as other reptiles and mammalia who have teeth and hind legs, they might be supposed to have inherited these organs ; just as, for example, a child sometimes has a mole or other mark upon its body in exactly the same place as its great grandfather had before it.

Another still more remarkable fact was that pointed out by Von Baer, that the embryos of higher animals, such as quadrupeds, before they are perfectly formed, cannot be distinguished from the embryos of other and lower animals, such as fish and reptiles. If animals were created separately, why should a dog begin like a fish, a lizard, and a bird, and have at first parts which it loses as it grows into its own peculiar form ?

These were facts entirely belonging to living creatures, but now others sprang up about fossil species which were equally puzzling. We know that certain animals are

only found in particular countries ; kangaroos and pouched animals, for example, in Australia ; and sloths and armadillos in South America. Now it is remarkable that all the fossil quadrupeds in Australia are also pouched animals, though they are of different kinds and larger in size than those now living ; and in the same way different species of sloths and armadillos are found fossil in South America ; while in the rocks of Europe fossil mammalia are found, only slightly different in form from those which are living there now. Naturalists therefore asked themselves again — ‘ Would it not seem likely that the living pouched animals of Australia, and the sloths and armadillos of America are the descendants of the dead ones in the rocks, although they have in the course of long ages become rather different from them ; while oxen, bears, wolves, etc., are also the descendants of those which are found buried in the rocks of Europe ? ’

**Gradual Succession of Animals which have appeared upon the Globe.**—This seemed still more likely as the study of geology advanced, and it became clear that a gradual succession of higher and higher animals had appeared upon the globe. Thus, in the oldest rocks containing fossils, we find no monkeys, no quadrupeds, no reptiles, no amphibians such as our frogs, but only shells of marine animals, and a few bones of fishes, of kinds quite different from those now living.

Then in rocks above these we find the fish becoming very abundant and varied, and higher still we meet with footprints of some animal with feet ; and the bones of an amphibian, somewhat like a frog, are next found. In these times the fish began to cease to be monarchs of the water, for a little higher up huge swimming reptiles, like our

crocodiles and lizards, but much larger, have left their bones in the rocks. Next come reptiles with wings, which measure sixteen feet across from tip to tip, and we must picture these huge flying lizards, with wings like bats, roaming over the globe with no higher animals to persecute them.

But they were only to have their turn, for in rocks formed a little later there appear two skeletons, one of a small creature half reptile half bird, about the size of a pigeon, and the other of a real bird with some of its feathers still remaining; and in beds of about the same age there occurs the jaw of a small insect-eating animal something like an ant-eater. Birds and quadrupeds therefore had now begun to exist, and soon the bones of pouched animals are found, and then of mammalia, like our moles and shrews; and from this time the reptiles become smaller, as if they were kept down and gradually destroyed by the higher animals, and the quadrupeds become larger and more powerful; till, in those beds which Cuvier studied near Paris, we find the gigantic elephant and rhinoceros-like animals we spoke of before; while in beds of about the same age occur the first bones of monkeys.

This is a very rough sketch of the order in which animals are found in the earth's crust. The lower kinds first, and then gradually higher and higher forms as they come near to our own time; and if we could study them more closely you would see that in rocks nearly of the same age the forms are always very like each other, while the farther apart the formations are, the more different are the animals. It is true that there are very few close links to be found between fossil animals; but when we remember that nearly all the rocks in the earth's crust are made out of others which have been destroyed, it is scarcely wonderful that so few

skeletons should be found of those that were once buried, and it is not likely that many of these would be just the intermediate forms we want. Still some have come to light, for a bird-reptile has been found in the rocks of Kansas, in America, which has a skeleton like a bird, but teeth and jaws like a reptile; and a reptile has been dug out of the Stonesfield slate in England, which Mr. Huxley says must have hopped like a bird, having legs, neck, and a bird-like head, while it had, nevertheless, teeth like a reptile. Again, horses have been found in the rocks of America which have separate toes, and others in which the toes are beginning to grow together, showing how they may have been gradually altered into our one-toed horse.

And here again, those who studied fossil animals asked why these forms should succeed each other, gradually passing on into the living forms of our own day, which are all slightly altered copies of these fossils of the rocks?

**How can Plants and Animals have become altered?**

—It was questions such as these which seemed to call for answers, and to find none except the one proposed by Lamarck; namely, that the different kinds of animals are all descended from a few simple forms. If this were so, then it would be quite natural that higher and higher forms should appear gradually upon the earth, and that the kinds most alike should follow directly upon each other, those which are now living being very like their ancestors in the newest formation in the earth's crust. It would also help us to understand why animals of the same class should have the same bones, and why some should have parts remaining in their body which are no longer of any use; and lastly, it would explain why naturalists have so much difficulty in distinguishing nearly related species.

But though these reasons made it seem very likely that

all animals are only different branches from one stem, yet this could only be a mere speculation, unless some one could point out what has made them differ so much from each other. Lamarck, as we have seen, could not do this, and therefore his suggestion was passed by; and it was not till five-and-twenty years ago that two naturalists, Mr. Darwin and Mr. Wallace, discovered a law which is certainly true in itself, and which accounts for many of the facts. Their theory, which we must now consider, was so new that it was opposed on all sides, just as the Copernican theory was opposed in the sixteenth century, the circulation of the blood in the seventeenth century, and the theory of combustion, which overturned phlogiston, in the eighteenth century. We live in the midst of the discussion about the origin of species, yet even within the short space of a quarter of a century it has almost outlived opposition, and there is scarcely a naturalist of note who does not in one form or another accept the Darwinian theory, which we must now try to understand.

**Theory that Natural Selection has caused the various kinds of Plants and Animals to differ permanently from each other,—Darwin, 1809-1882.—**The Theory of Natural Selection, or the Darwinian theory as it is often called, was chiefly worked out by the great naturalist Charles Darwin, who was born in 1809 and died in 1882. When he was only two-and-twenty, Mr. Darwin went in her Majesty's ship 'Beagle' to survey the coast of South America and sail round the globe; and on his return he wrote an account of the geology and natural history of the countries he had visited. He tells us himself that even so early as this he noticed many facts which seemed to him to throw light on the difficult question of the origin of the different species of plants and animals; and he spent twenty years

carefully collecting in England all the knowledge he could upon the subject. But he did not publish it, for he wanted more and more evidence; and as Newton waited sixteen years for more convincing proof before he announced his theory of gravitation, so Mr. Darwin would have delayed much longer than he did if a remarkable circumstance had not obliged him to speak.

It happened that while Mr. Darwin was working in England, another great naturalist, Mr. Alfred R. Wallace, who was then in the Malay Archipelago, also thought that he had discovered the way in which animals are made to vary in the course of long ages. He sent home a paper on the subject, and, though he had never heard of Mr. Darwin's theory, it was found that he had worked out the same result, sometimes almost in the same words.

Sir C. Lyell and Dr. Hooker of Kew were so much struck with the fact that these two men had solved the problem almost precisely in the same way, that they begged Mr. Darwin to allow one of his papers, written many years before, to be published with Mr. Wallace's, and the two essays were read the same evening, July 1, 1858, at the Linnæan Society. A year later, in November 1859, Mr. Darwin's famous work, 'The Origin of Species,' was published.

'The Theory of Natural Selection,' or the choosing out by natural causes of those plants and animals which are best fitted to live and multiply, rests upon a few simple facts which you can understand.

Firstly, all living beings multiply so rapidly that there would be neither room nor food enough upon the earth for them if they were all to live; therefore immense numbers must die young, and those will live the longest and have children to follow them who are best fitted for the kind of life they have to lead.

Secondly, no two living beings are ever exactly alike ; but children always inherit some of the characters of their parents, so that if any being has a peculiarity which makes it better fitted for its life, and consequently lives long and has a large family, some of its descendants will most likely inherit that peculiarity.

Now it is not difficult to understand that if useful peculiarities of different kinds are handed down in this way from parent to child, those who inherit them will in time begin to be remarkable for different qualities. For example, suppose that in a nest of young birds, one with strong wings lives and has young because it can fly far and get food, while another also lives and has young because its feathers are dark, and the hawks cannot see it in the grass. Then those descendants of the strong-winged bird which also have strong wings, will be most likely to live on in each generation, and will pass on this peculiarity to their children ; while the descendants of the dark-coloured bird will also survive in each generation exactly in proportion as their plumage is adapted to hide them ; and thus the strong-winged birds and the dark-winged birds will in time become very different from each other. This is roughly the theory of 'Natural Selection ;' that nature allows only those animals to live which in some way escape the dangers which threaten their neighbours, and thus in time the race becomes altered to suit the life it has to lead.

There is only one difficulty. It is clear that the strong-winged birds must not pair with the dark-winged birds, or otherwise both peculiarities would come out in the young birds, and the two kinds would no longer remain distinct. And this is the one stumbling-block in the theory ; we have never yet been able to trace out two varieties of an animal which have become so different that they do not pair

together. You should fix this difficulty firmly in your mind, because it is almost the only real one we shall meet with. Mr. Darwin's answer to it is, that we have only watched plants and animals for such a short time, and even then not with this idea in our minds, so that we are not likely to have found a case to help us. It has indeed been observed that animals, if left free to choose, do often pair with those which resemble themselves, and do in some cases show a dislike to those that differ; still this is not proved to be always the case, and it must be acknowledged to be a difficulty.

**Selection of Animals by Man.**—But now setting this aside, let us see what proof there is that animals vary, and that they can be picked out, so that any peculiarity may become stronger in each succeeding generation. The best instance is in pigeons. All our pigeons come from the common wild rock-pigeon; and the way in which all our pouters, fan-tails, barbs, and other pigeons have been produced, is by merely picking out from the young ones those which had either large crops, or wider tails, or longer beaks, and pairing them together, so that the young birds had these peculiarities still more strongly. The same thing is true of our different kinds of oxen, sheep, horses, and fowls; so we see clearly that different varieties can be produced by choosing out particular animals. Man does this quickly, because he only attends to one peculiarity, which interests him; but nature does it very slowly, because no animal can live unless every part of it is fitted for its life better than in those which are killed off.

**Selection by Natural Causes.**—Now Mr. Wallace has calculated that one pair of birds having four young ones a year, would, if all their children, grandchildren, and great-grandchildren, lived and were equally prolific, produce about



*two thousand million descendants in fifteen years.* And Mr. Huxley tells us that a single plant producing fifty seeds a year would, if unchecked, cover the whole globe in nine years, and leave no room for other plants.

It is clear, therefore, that out of these numbers millions must die young, and it is only the most fitted in every way that can live and multiply. One example from Mr. Darwin's book will show you how complicated the causes are which determine what particular kinds shall flourish. He tells us that the heartsease and the Dutch clover, two common plants, can only form their seeds when the pollen is carried from flower to flower by insects. Humble-bees are the only insects which visit these flowers, therefore if the humble-bees were destroyed in England there would be no heartsease or Dutch clover.

Now the common field-mouse destroys the nests of the humble-bee, so that if there are many field-mice the bees will be rare, and therefore the heartsease and clover will not flourish. But again, near the villages there are very few field-mice, and this is because the cats come out into the fields and eat them; so that where there are many cats there are few mice and many bees, and plenty of heartsease and Dutch clover. Where there are few cats, on the contrary, the mice flourish, the bees are destroyed, and the plants cease to bear seed and to multiply. And so you see that it actually depends upon the number of cats in the neighbourhood how many of these flowers there are growing in our fields.

But now let us suppose for a moment that among the field-mice there are some whose skin has a slightly peculiar smell, so that the cats do not eat them when they can find others. Clearly these mice would live longest and have most offspring; and of these again, those with strong smell-

ing skins would live ; and so after a time a new race of mice would arise which would be independent of the cats, and the bees would have a poor chance of living, and consequently the flowers of bearing seeds.

But this might in the end give rise to quite a new race of plants, for it is believed that some moths would visit the clovers, only, as Mr. Darwin points out, they are not heavy enough to weigh down the petals of the flowers so as to creep inside them. But as no two flowers are ever exactly alike, it is very likely that the petals of some blossoms will droop a little more than in the others, and so if the bees became scarce, these blossoms with drooping petals might live on, because the moths could creep into them and carry their pollen from flower to flower ; and thus a new race of clover with drooping petals might spring up independent of the cats, the mice, and the bees, and would become a new species.

You must especially notice in this imaginary example that it is only *useful* variations which can be passed on from generation to generation. If the smell of the mice (which would probably come from some peculiarity in the pores of the skin) did not preserve them from the cats, the strong-smelling mice would not live, and a peculiar race would not arise ; in the same way, if the drooping leaves of the clover did not enable the moths to enter, those plants would die out like the others. And this is one of the most striking facts which Mr. Darwin has pointed out ; namely, that no variation will continue and increase from generation to generation unless it is useful to the plant or animal which possesses it ; so that if this theory be true, every beautiful colour which we admire in animals and plants, every minute detail in their form and structure, is not only to be admired for its beauty, but because it is an evidence of that won-

derful harmony of nature which keeps every part, however insignificant, exactly fitted to do its work in the one great scheme of creation.

**Difficulties in Natural History explained by Natural Selection.**—And now, if we adopt Mr. Darwin's explanation, you will see how St.-Hilaire and Cuvier could both be right when the former said that all animals are formed on one plan, and the latter, that each part of an animal is exactly fitted to work harmoniously with the rest of its body. For if animals have been gradually altered the one from the other, it is natural they should all be made on one plan; as, for instance, if the ancestor of the bat, millions of years ago, was also the ancestor of those animals out of which the horse has come, then the bones of the bat's wing may well be similar to those of the horse; while, on the other hand, if no variation can become fixed, and develop into important parts or organs unless it is useful, it is clear that all the parts of an animal must have been gradually modified so as to fit each other and to work in the best possible way for its well-being. Again, it explains why the living animals in a country should be of the same class as those found fossil in the earth, though slightly different from them. For if in Australia the ancestors were pouched animals, it must take a very long time before their descendants could be anything else, although they might begin to differ in many points of a less fundamental nature.

Lastly, it enables us to understand why we find the lower forms of life in the oldest rocks, and why gradually, as animals multiplied and the struggle for life became greater, more and more complicated forms should arise, from the improvement and inheritance of specially useful parts; so that the higher animals have a greater number of different parts to perform different actions, just as a civilised country

with a great number of skilled people in it has men of different trades and professions, one to brew and one to bake, one to dig the ground, and to grow cotton and flax, and another to weave them into garments.

This will give you a very small glimpse of some of the apparent anomalies which are explained by the theory of natural selection. The subject is so difficult to understand thoroughly, that you must not expect to have more than a slight notion of it, and must be content for the present with knowing that our greatest living naturalists, who have made a careful study of living and fossil animals and plants, all believe it to be true.

And as this is so, it is extremely foolish to be prejudiced against it, as some people are, by the idea that animals formed in this way can be less God's creation than if they were made in any other way. The whole history of science teaches us that men, in all ages, have constantly taken false alarm when it has been shown that God's ways are not our ways, and that the universe is governed by far wider and more constant laws than we had imagined in our little minds. But in the same way as the planets are none the less held in God's hand because we now know that it is by the law of gravitation that He governs their movements, so every plant and animal must be equally His creation, in whatever way they have been developed. Above and beyond all these laws which we can trace there remains ever the One Great and Supreme Creator whom Anaxagoras worshipped instead of the heathen gods of Greece (see p. 14), when his fellow-countrymen condemned him as an unbeliever because he believed not in many, but in One God.

A humble, earnest spirit seeking knowledge must indeed find in modern science a deep revelation of the Unity and Unchangeableness of the Creator. Instead of many widely

---

different sciences standing each alone, which the great men of earlier centuries worked out, we are beginning to be able to discern one constant power working through them all; while still new fields of discovery, such as that which spectrum analysis has only lately opened out to us, help us to bear in mind how little we know, and how much more vast than anything that we can imagine must be the great scheme of Creation which is being worked out around and within us.

---

*Chief Works consulted.*—Darwin, ‘Origin of Species;’ Wallace, ‘Natural Selection;’ Huxley, ‘Lectures to Working Men;’ Lyell, ‘Principles of Geology.’

## CHAPTER XLII.

## SCIENCE OF THE NINETEENTH CENTURY (CONTINUED).

Recent Advances in Science—Discoveries of Heavenly Bodies—Leverrier's Analysis of the Planetary Orbits—Molecular Theory of Gases—Liquefaction of Permanent Gases—Discoveries by Crookes—Advances in Biology—Concluding Remarks.

WE have now arrived nearly at the end of the wonderful story of how man has slowly progressed in his efforts to understand the laws of nature. The advances which have been made in the various branches of science during the last fifty years have been so vast that it must be many years before they can find their relative place in a history of science. Yet it may be useful, in conclusion, to cast a parting glance upon the nature of the work that has been performed, even if it only serves to help us to realise the importance of the problems which are occupying the great scientific minds of our day.

It is scarcely possible to overrate the advantages possessed by the student of science now over those who first fought their way upwards in past centuries. Instead of rough instruments, constructed under great difficulties like the telescopes of Galileo and Sir W. Herschel, magnificent refracting telescopes, with large achromatic lenses, are now found in all good Observatories. The finest refracting telescope in the world is that of the United States Naval Observatory, Washington, with an aperture of twenty-

six inches, while one still larger is being constructed for the Vienna Observatory. The finest reflecting telescopes are Lord Rosse's, of a six-foot aperture, and that of the Melbourne Observatory, Australia, of a four-foot aperture.

Again, self-registering instruments are now at work in every part of the world, recording in a permanent form phenomena which had formerly to be registered at intervals by observers who, however well trained, were liable to make mistakes. Clockwork regulates the movements of the telescope itself, while microscopes enable the observer to read off the most delicate measurements. And, what is of still greater importance, photography enables us to obtain permanent records of passing astronomical phenomena. Thus photographs were taken of the ingress and egress of Venus during the late transits, and though these were imperfect, yet there is little doubt that such attempts will be successful in the end. Hourly photographs are also now being taken of the sun whenever it is visible, while Mr. Rutherford's beautiful photographic pictures of the moon render us familiar with all the details of its surface.

**Discovery of new Heavenly Bodies, 1877-1878.**—With all these appliances many features of the heavenly bodies are observable which were before indistinct. On the nights of August 11 and 17, 1877, Professor Asaph Hall discovered with the Washington telescope two of the smallest heavenly bodies (meteorites excepted) which have ever yet been seen. These are two satellites revolving round the planet Mars. It is difficult to be certain how large they are: the one which is farther from the planet is the smaller, measuring probably, according to Professor Pickering, about six miles across, and it moves round Mars in 30 hours 17 minutes 53 seconds. The inner one is brighter, and measures probably about seven miles

across; its period of revolution is 7 hours 38 minutes. These two satellites are named Deimos and Phobos, or Fright and Flight, because Homer makes these attendants upon the God of Battle. They are so near to Mars that if there be living beings on that planet with eyes and telescopes like ours, they will be able to tell whether their moons are inhabited, for the inner one is only 4000 miles distant, or sixty times nearer to Mars than our Moon is to us.

Another important discovery, believed on good grounds to have been made within the last few years, is that of one, and perhaps two, planets revolving between Mercury and the sun. We shall see presently that Leverrier's analysis of the planetary orbits points to a probability that some bodies of this kind exist nearer to the sun than Mercury, and in 1859 a French physician, M. Lescarbault, asserted that he had seen a round body crossing the sun's disc which Leverrier believed to be a planet, and called by the name of Vulcan. During the eclipse of the sun on July 29, 1878, Professor Watson of the Observatory of Michigan devoted all his attention to a search for this planet, and though he did not find it, he saw two other bodies which he believes to be planets, but whose positions do not either of them agree with that of Lescarbault's Vulcan, so that if future observation confirms these discoveries we should know of three intermercurial planets.

**Travelling Stars studied by the Spectroscope.**—Nor is the telescope now the only instrument by which we can penetrate the starry depths and bring home their secrets, for the spectroscope enables the chemist actually to analyse the materials in distant suns, and ascertain both their physical and chemical composition. Moreover, it enables us to measure movements otherwise inappreciable, and actually to calculate the rate at which some stars are



travelling towards, and others away from, our earth. It is an old conjecture that a star has a red appearance when it is moving from the earth, or blue if it is moving towards it, but it has been shown that unless this movement is very great, the change of colour would not be perceptible to ordinary observation. The German physicist, Dopler, in 1841, was the first to point out that the rate of movement of a star might be measured by its change of colour, because this change depends upon the succession of light-waves upon the eye being more rapid when a star is approaching, and less rapid when it is receding. Such a change, however, can only be rendered perceptible by the spectroscope, and in this way Dr. Huggins measured the movement of Sirius or the dog-star. It must be remembered that the position of the lines which form the spectrum of any star depends upon the rapidity of the vibrations of the rays which produce them. Now, if a star be receding from us, it will send fewer vibrations in a second, consequently its colour will change, and its lines move towards the red end of the spectrum. It is necessary, therefore, first to identify some of the lines of a star-spectrum with the lines of some substance such as hydrogen or sodium, and then to observe how far the star lines differ from *exact* coincidence with the lines of the incandescent gas. Dr. Huggins established by this means the fact that Sirius is moving away from our earth at the rate of about 25 miles a second, after allowing for the motion of our own solar system through space. This method has now been applied to a large number of stars, not only by Huggins and others, but also on a large scale at the Greenwich Observatory.

**Leverrier's Analysis of the Orbits of the Planets, 1875.**—Thus far it has been the gradual perfection of instruments, and the use of them in patient research, which

has given us our vantage ground. But meanwhile the great mathematical minds have not been idle in demonstrating that 'order is heaven's first law,' and after thirty-six years of constant labour M. Leverrier has completed the analysis of the movements of the eight large planets, so that the student of astronomy has now before him a chart by which he can check the actual revolutions in our planetary system for two thousand years to come. It is impossible for any but mathematicians properly to appreciate this work, but we may form some idea of it by picturing to ourselves the problem which Leverrier had to solve.

We must first of all remember the fact proved by Newton (see p. 148), that not only does the sun attract the planets, and the planets the sun, but that every planet attracts every other planet in the solar system. Now, as no two planets revolve round the sun in the same time, they are constantly changing their positions with regard to each other, just as, for example, the short and long hands of a clock are sometimes near together and sometimes far apart: only in the case of the planets it is as if there were eight hands moving, all at different rates, and these rates do not bear an even proportion to each other. Moreover, the planets do not move all upon one flat surface, like the face of a clock, but their orbits are in various planes, and these planes themselves are subject to irregular motions. Lastly, each planet moves in an ellipse, and these ellipses vary in different ways. From this it arises that the planets cross each other's paths at very varying intervals, and are incessantly assuming different positions with regard to each other. Now, as the attraction of two bodies becomes stronger as they approach each other, it is clear that as the positions of the planets vary, their mutual attractions vary too, and the

task which Leverrier set himself was, to calculate all these attractions and thus to discover the mass of each planet by the effect which it has upon the other planets, and the effect they have upon it.

As our earth is one of the planets, the first thing was to find out by the *apparent* motion of the sun what is the real path of our earth and how it is affected by all the others, and from this to go on to each of the planets in turn. But it must be remembered that no two planets can be studied as if they were alone in the heavens; on the contrary, they are never free from the attractions of all the other six, whose positions are constantly changing, so that the movements cross and re-cross each other like the waves of a troubled sea.

In order to disentangle this complicated series of changes, it was necessary to gather together all the observations made of the positions of each planet from the earliest ages, and to combine the whole mathematically into one complete theory, in which all the movements should be truly and accurately accounted for. This Leverrier undertook, and it was in the course of his work that he found some movements of Saturn and Uranus which were not produced by any of the known planets, and he was thus able to announce the existence of the planet Neptune (see p. 304). He next found that Mars and Mercury were pulled out of their path by some matter for which he could not account. As far as Mars is concerned, this matter proved to be upon our earth, whose mass had been reckoned too low, but in the case of Mercury the cause is not yet certain, although the supposed planet of Lescarbault and the two small bodies observed by Watson may probably help to explain the irregularity.

With these and a few other trifling exceptions, Leverrier succeeded in 1874 in completing his gigantic task, and in

computing the position of the four most distant planets, Jupiter, Saturn, Uranus, and Neptune, for a period of 2000 years from 1880 at intervals of 500 years, so that future astronomers will be able to calculate at the periods 2350, 2850, 3350, and 3850, whether the movements of the planets have followed the same order as in times past, or whether any disturbing influence has arisen.

**Physics and Chemistry.**—Thus the student of astronomy now finds opened out to him almost boundless fields of knowledge, with appliances and methods of research some of which were not even dreamt of fifty years ago, and if this is true of one of the most ancient of the sciences, how much more so is it of physics and chemistry, which have advanced so rapidly in our day as to be almost beyond the grasp of ordinary minds. Familiar as are the names of Graham and Andrews, Faraday and Tyndall, Helmholtz, Clerk-Maxwell, and Sir W. Thomson, yet the structure of matter, the theories of heat, electro-magnetism, and thermo-electricity, and similar subjects in which their grandest work has been accomplished, are only to be thoroughly understood by scientific men.

Perhaps the best way of giving some notion of their investigations is to state roughly—firstly, that they have followed *energy*, or the power of doing work, into its most hidden forms, detecting its action among the particles of a gas, measuring it in the electric current, and showing how it may be lost to us by dissipation (see p. 353) even though it is in itself indestructible; and secondly, that they have succeeded in measuring not only the movements, but even the size of the smallest existing portions of matter, and have come very near to telling us even the nature of the atoms of which matter is composed.

The celebrated Swiss mathematician, Daniel Bernoulli, in

the seventeenth century, was the first to suggest that gases are formed of free particles or *molecules* in constant motion, and that the pressure of a gas upon the sides of the vessel containing it, is caused by the agitation of molecules within. Thus, for example, an ordinary air-ball, if held near the fire, expands, because the molecules of the air within move with more energy and beat with more force against the sides of the bag containing them.

In our time Graham, Joule and Andrews, Clausius, Clerk-Maxwell and Boltzmann, Helmholtz and Sir W. Thomson, have enabled us to see these molecules with our imagination, dashing to and fro, hitting one against the other, and flying off in different directions and at different rates. They have ascertained, for example, that in hydrogen gas, at the ordinary temperature and pressure of our atmosphere, each molecule of hydrogen is moving at the rate of about 6225 feet in a second, yet it must perform all its motions in an incredibly small space, for it is constantly striking against some other molecule, so that in that second of time it rebounds more than seventeen thousand million times. This number of collisions of the molecules will always correspond to the same temperature and pressure of the gas. But if more energy be imparted to the molecules the temperature will rise, for the more quickly they dash to and fro and strike each other the higher the temperature will be. When we heat a gas we are in fact increasing the energy of the molecules and making them dash to and fro more rapidly. This rebounding of the molecules is the reason, as Clausius showed, why, when two gases are brought together, it takes them some time to mix thoroughly, the new molecules have to fight their way among those which are already in the field. Dr. Graham had long before shown experimentally that the rate of diffusion is inversely as the square roots of

the densities of the gases, and we now know that the vibration of the molecules themselves is in this ratio. The collisions also explain, as Clerk-Maxwell has shown, why heat is conducted so slowly from one part to another of a gas. The molecules which we make more energetic by heat at one point hit against others and communicate their energy, and these again to others, till they all move at equal rates and the gas has an even temperature throughout.

And now, perhaps, we might think that, having arrived at these infinitesimal movements among the molecules of matter, we had gone as far as human power could penetrate. But it is not so: Loschmidt in 1865, Stoney in 1868, and Sir W. Thomson in 1870, were able, in following out the discoveries of Clausius and Maxwell, to measure actually the size of the molecule itself. They tell us that two million molecules of hydrogen placed in a row would measure one millimetre; so that about 50 million would lie side by side in an inch. Nor is this all, for the spectroscope has revealed that even these minute particles are not mere rigid atoms. We have seen (p. 332) that a gas gives a spectrum of bright lines; now these lines are caused by the vibration of the parts of the molecule itself, in consequence of its having been shaken by coming into collision with another molecule. Thus we have to picture to ourselves these molecules not only dashing to and fro and hitting each other, but each one of them during its passage between one concussion and another, quivering with the shocks it receives, and so giving out waves of coloured light, just as a bell when hit gives out waves of sound. The study of these vibrations and of the nature of the atoms of which these molecules are composed, forms some of the grandest work accomplished by Helmholtz and Sir W. Thomson, while the theory of electro-magnetism worked out by the late Professor Clerk-Maxwell rests upon

a series of vortices in and between these molecules, and is the best solution at which mathematicians have yet arrived on the subject.

**Liquefaction of the Permanent Gases.**—Turning now from these wonderful and almost inconceivable results of mathematical physics, to chemical experiments in the laboratory, we learn that within the last few years a great victory has been gained over those stubborn gases which had till now refused to be reduced to liquids. In 1823 Faraday first liquefied chlorine and several other gases, and subsequently Dr. Andrews, of Belfast, went still farther, and showed the reason why those which remained stubborn could not then be overcome.

If we picture to ourselves a gas as being composed of free molecules flying about in all directions, we can understand that if these are pressed very closely together they may come sufficiently near to be held together by cohesion, and in fact, many gases, such as chlorine, hydrochloric acid, and ammonia, can be reduced to liquids merely by being compressed at the ordinary temperature of our air, or very little below it. But Dr. Andrews has shown that by heating liquids we can always arrive at a *critical point* of temperature (differing for different substances), at which no amount of pressure will keep them liquid. If we heat a liquid with its vapour in a sealed tube, as we arrive near to this particular temperature the surface of the liquid loses its natural curve in the centre, and flattens more and more, thus showing that the molecules are held together less and less firmly, until at the *critical point* the force of cohesion loses its power altogether, and the whole contents of the tube become vapour. In fact, the energy of movement of the molecules has become so great that it quite overcomes the attraction which each molecule has for the other, and so

long as the vapour is kept at this temperature, no amount of compression will force it to become a liquid. Thus, for example, carbonic acid at a temperature of  $35.5^{\circ}$  Cent. may be compressed under 108 times the weight of our atmosphere, till 430 pints of it are forced into a vessel only holding one pint, and yet it will remain unliquefied. But directly it is reduced below  $30.92^{\circ}$  Cent., which is its *critical point*, the molecules do not move with sufficient energy to resist cohesion, and the vapour becomes liquid at once without suddenly changing its volume or giving out any heat.

Now, those gases, oxygen, hydrogen, and nitrogen, which were called 'permanent' gases, have each their 'critical point,' so enormously below all ordinary temperatures that no one until December 1877 had succeeded in obtaining cold and pressure enough to reduce them to liquids. But in that month M. Raoul Pictet, of Geneva, and M. Cailletet, an iron-founder at Chatillon sur Seine, were fortunate enough to liquefy oxygen, each of them independently of the other.

M. Cailletet put his oxygen in a small tube under enormous pressure, surrounded it by a freezing mixture, and then let it suddenly escape from the tube. The gas, already intensely cold ( $29^{\circ}$  below  $0^{\circ}$  Cent.), became so much colder by expanding as it rushed out, that it liquefied into minute drops, giving the appearance of a mist. M. Pictet had a more elaborate apparatus, in which, by a double process of freezing, by means of sulphurous acid and carbonic acid, he obtained a cold of  $140^{\circ}$  Cent. below the freezing point, while he exerted a pressure upon the gas 650 times greater than the pressure of our atmosphere. He then opened the stopcock, and the oxygen, set free, shot out in a liquid stream.

The next step was made by M. Cailletet on the last day



of 1877, when he compressed not only nitrogen and hydrogen, but also atmospheric air into liquids, before the leading scientific men of Paris. The nitrogen appeared in drops, but the hydrogen only as a faint mist. Lastly, M. Pictet, on January 11, 1878, under a pressure 650 times that of our atmosphere, and with a cold of  $170^{\circ}$  C., obtained a jet of liquid hydrogen, which became partly solid and struck on the floor with 'the shrill noise of metallic hail,' thus confirming the idea first suggested by Faraday, that hydrogen is a metal. These experiments have removed the last barrier between gases and vapours, and we now know that all substances only require suitable conditions to take either of the three forms of solid, liquid, or gas. Thus M. Cailletet and M. Pictet have abolished the belief in 'permanent gases.'

**Matter in an Ultra-gaseous State.**—Nature, however, is always ready to offer new problems as fast as old ones are solved, and in the very same year in which the gases were conquered at the one end, where they approach liquids, they have been shown by Mr. Crookes to present some most perplexing facts at the other end of the scale, where they become comparatively poor in molecules as in a so-called vacuum (see p. 120). It is well known that even in the most perfect vacuum which we can obtain in a glass tube, an enormous number of molecules of gas or air always remain, and it is in consequence of the movements of these molecules under the influence of light or heat that a kind of windmill can be made to turn inside those curious glass bulbs, called by Mr. Crookes 'radiometers.' He has now shown that in very high vacua—about the millionth of an atmosphere—in consequence of there being comparatively few molecules in the bulb, their mean free path is long enough to enable them to travel across without materially

interfering with each other. In this free state most curious effects are produced by currents of electricity. The molecules driven from the negative pole hit with such force against the glass that they make it glow with phosphorescence, and substances such as the diamond and the ruby, which are scarcely phosphorescent under ordinary circumstances, if placed in the path of these molecules, shine with extraordinary brilliancy. But the point of most importance is that the gas at this high exhaustion behaves quite differently from ordinary gases, owing probably to the greater freedom of molecular action, and Mr. Crookes believes that it will be found to form a fourth state of matter, as distinct from the gaseous as the gaseous is from the liquid state. The study of the electrical phenomena in vacuum tubes is still in its infancy, but it may be that those who come after us may look upon it as one among the greatest advances in science made in our century.

It may perhaps seem strange that, while speaking of these discoveries of theoretical interest in physics, we omit the description of the numerous inventions which have been crowding upon us in the last few years, such as the phonograph, the microphone, and the electric light, but it must be remembered that these are not strictly new discoveries in science, but applications of principles already discovered. Though of surpassing interest, they must be studied in detailed works, or find their place in a history of inventions. The last fifty years have been essentially a period of the application of scientific knowledge to practical life, and if any justification were needed of the study of pure science, it may easily be found in the fact that our railways, our telegraphs, our steamships, our manufactures, which have done so much for the prosperity of England, are all the results of scientific principles studied at first for their

own sake, and many of them apparently as far removed from the affairs of daily life as the molecular theory of gases, or the question as to an ultra-gaseous state of matter.

With regard to pure chemistry, we can add but little of general interest to what has been given in Chapter XXXVII. This is not because abundant work has not been done, but because technical knowledge is required to understand it. We have already said that the chemistry of organic compounds has become a most important branch of chemistry, since it has been shown that many of the substances supposed to be peculiar to living bodies can be made artificially in the laboratory. It has, in fact, opened the way for a far more real knowledge of the effects of medicine, of the working of poisons, of the chemical action of food in the body, and of many conditions of health and disease, for if the physician can know the actual chemical changes produced within the body with great accuracy, he is no longer working in the dark, as he was when he could merely judge by outward effects. In quite another branch, less important, but still of great interest, the chemistry of organic compounds has been most useful. It has led to the discovery of all the beautiful colouring matters which are now prepared both from living plants and from the coal-tar which comes from plants of bygone ages.

It would be impossible to give a list even of the leading chemists of the present day. Wöhler, Græbe, Hoffmann, Würtz, Frankland, and Williamson, are only a few among equally illustrious names, and it must yet be many years before a fair sketch could be given of the history of the chemistry of the organic compounds; but we may be sure that such a future historian will, as Dr. Andrews has said, 'have to record a succession of beneficent triumphs, in

which the effects of science have led to results of the highest value to the wellbeing of man.'

**Biology.**—It is, however, above all, in the sciences relating to life, that the young student now finds himself on the road to grand results whichever way he may turn his steps. Fifty years ago the naturalist might, and did, find great interest in discovering new species of animals and plants, and studying their habits and nature; while the anatomist and physiologist classified forms according to their structure, and thus we were beginning to arrive at a fair general view of the plant and animal kingdoms.

But here the interest ended; for there was then no idea that the structure, nature, and habits of living beings could help us to unravel the history of past life upon the globe; nor that every hair, and bone, and tint of colour is a clue to the working of general laws by which the various forms have arisen and filled the earth. This conception was only possible after Darwin had shown in his *Origin of Species* (see p. 448) that 'the structure of each part of each species, for whatever purpose used, will be the sum of the many inherited changes through which that species has passed during its successive adaptations to changed habits and conditions of life.'

Now, see what a field this opens to the most humble student of nature, if he only work conscientiously. Formerly, a plant or animal stood alone, and the question, how it came to be what it is and where it is, did not arise. But now, taking a plant, for example, we have to learn in what it differs from the simplest plants known, and for what reasons it has gradually acquired the various parts by which it performs its functions. From this point of view, its roots and the way they grow; its leaves, the hairs that cover them, the chlorophyll which they use to assimilate

their food, even their movements by night or by day, have all a real significance, as Dr. Julius Sachs has so graphically described in his works. Again, the study of the curious structure of flowers, their manner of forming their seeds, and the numerous contrivances for attracting or repelling insects, has become a science in itself, enriched by the countless observations of Darwin, Hermann Müller, Kerner, Sir John Lubbock, and others. Yet still so much remains to be done that any one who will work in the field or garden, with the theory of evolution as his guide, may add to the links in Nature's chain, by following which we are gradually tracing out the past history of plant life.

In the same way the food of plants, and the manner in which many have been driven to procure it, so to speak, illegitimately, now offers a new line of research. Parasites, epiphytes, saprophytes, all help us to trace out 'adaptations to changed conditions of life,' and to learn how a plant loses organs, or gains new ones, as it leaves the ordinary road of plant life.

Take, for example, the carnivorous plants, such as the *Dionæa*, the *Drosera* or sun-dew, and the *Pinguicula*, which actually feed upon the juices of insects and other small animals which they enclose in their leaves. As long ago as 1768 an English Botanist named Ellis pointed out that the leaves of the *Dionæa* close over any unfortunate insect which alights upon them, and cover it with a sticky fluid, and Dr. Curtis, in 1834, showed that this fluid acts like the gastric juice of an animal in digesting and dissolving the animal matter. Within the last few years, however, Dr. Burdon Sanderson and Mr. Darwin have added a great deal to our knowledge of these carnivorous plants. It seems that even the lightest gnat resting on the glands of the leaves of one of these species excites the minute hairs

with which they are covered and causes the leaf to close, and Dr. Sanderson has shown that the same kind of electrical current is set up in the leaf by this movement, as occurs in our own muscles when they contract. The glands of the leaf next begin to pour out a sticky fluid, which dissolves the substances of the insect in just the same proportions and in the same manner as the gastric juice of our stomach dissolves the substances in our food ; and lastly, when the leaf unfolds, and the tentacles or little hairs rise up again, letting the refuse of the dead insect drop, the glands cease to give out the fluid until another insect is caught and the process begins again. The whole history of these carnivorous plants, though they are exceptional in the vegetable kingdom, is one of the most interesting that can be imagined, and forms another unexpected link between the nature of plants and animals, while at the same time we have no new organs created, but only modifications of those common to plant life.

Lastly, the mere collector of plants has quite a new interest in his work, for it is no longer an ultimate fact that any particular plant inhabits such or such a country. We have now to learn how it came there, to trace out its near relations in other countries, and to track its line of migration, just as we do that of a race of people ; explaining the modifications it has undergone by the length of time it has been living under new conditions, separated perhaps by a wide or impassable barrier from the home where first it arose, and where climate, soil, and the other plants among which it had to hold its own, were very different from those now surrounding it.

All these new interests are now within the grasp of the student of botany, together with a host of observations as to internal plant-structure, which find a new significance

when we read in them the gradual development of the functions of vegetable existence. Such men as Bornet, Muret, Schimper, de Bary, and others, have formed almost a separate branch of science in the study of the fertilisation of ferns and mosses, in which, nevertheless, we trace the connection of their modes of fructification with those of higher plants.

And when we turn to *Zoology* we find still more the healthy influence of a connected theory of life. For among animals there is such an immense variety of forms that the gradations of structure from the simplest to the highest, and their relations to each other, are a source of never-failing interest. Here the investigations of Parker, Balfour, and others (see p. 425), come in to help us, by showing the resemblance of the *embryos* of higher forms to the various gradations found in lower ones of the same or of nearly allied groups; and structures which were formerly merely puzzling anomalies now find their true place as links in the tangled web and woof of gradually developing animal life. So, too, when we see such different structures as the fin of a fish, the wing of a bird, the leg of a horse, and the arm and hand of a man, formed all on the same general plan, we no longer fall back helplessly on the idea that mere poverty of invention caused them to be created on the same lines. We have now a sufficient reason for their likeness in the fact that in ages long gone by they started from a common source; and every resemblance we trace, in parts now used for different purposes, is only additional proof of the marvellous way in which the same structures are adapted to changed habits and conditions of life. The classifications of animals, as given by Owen and Huxley in England, and Von Baer, Gegenbaur, and Hæckel in Germany, and in fact by all zoologists of our time, is

formed upon this conception of the actual relation of living forms, and so classification becomes no longer a mere arrangement for convenience, but a real statement of what we know about the links which bind the animal creation together. But in order to find these links an almost incredible amount of patient work must be done. It is not enough to understand merely the prominent characters of an animal. Its minutest structure must be known, for those parts of least importance in its own life are often of the greatest value to the naturalist, because they are the remains of some organ which was useful to a remote ancestor.

And when we are once started on this road, the help and suggestion which comes in from all sides is endless. As in plants so in animals, the study of structure by the microscope continues to add daily to the links in the chain. Thus, for example, Mr. Romanes has found in the Medusæ or jelly-fish traces of a nervous system, rudiments of eyes, and sacs of mineral matter, forming probably a rude hearing-apparatus, and it is probable that in time these researches may penetrate to even lower depths, so that the earliest beginnings of organs similar to our own may be traced in extremely simple invertebrate animals, and from thence upwards through the various branches of the animal kingdom till they reach their highest development in man.

On the other hand, if instead of going down to lower *living* forms we go back into the history of the past, *Palæontology*, or the study of fossil animals, first brought into prominence by Cuvier in 1812, teaches the same lesson. We saw (p. 420) how the discovery of animals slightly differing from living ones startled the world at the beginning of the century, and since then, year after year has been adding to the evidence (p. 446) that life in the



past helps us to complete the links between different living forms. Of late the chief additions to our knowledge have been made in America, where Dr. Leidy, Professor Cope, and Professor Marsh, have brought to light an immense number of fossil skeletons. Some of these help us to trace the gradual development of animals, as in the case of the horse, whose probable ancestors have now been found among the fossils of the Rocky Mountains, beginning with a little creature about the size of a fox, with real toes instead of a hoof; showing that, whereas the horse was formerly believed to have been always confined to Europe, till it was taken to America by the Spaniards, in real truth its ancestors were American, and it must have migrated to Europe in past ages. Others, again, are curious animals, half reptiles, half birds, and some of these are so enormous that it is difficult to imagine how they can have walked as they did upon their hind feet. The largest of these monsters, *Titanosaurus montanus*, found by Professor Marsh in Colorado, must have measured from fifty to sixty feet in length, and have been at least thirty feet high when it stood upright. It lived in the Cretaceous period, or about the time when all the chalk of our North and South Downs was being formed in the depths of the sea.

It is easy to see that such discoveries as these make us take a much grander view of the history of animals and their relationship than when it was believed that those creatures now known to us were all that had existed since the creation of the world, while, at the same time, they afford the evidence we need as to the lines of migration along which related living forms, now widely separated, have passed to distant lands. Thus, if it were not that we find marsupials in Europe in Triassic times, how could we explain the presence of opossums in South America and

kangaroos in Australia, both of them marsupial forms, yet existing at two ends of the world with no links between them? So that, here again, as in plants, geographical distribution has become a grand and interesting problem which all naturalists may help to solve, and the theory of the relationship and evolution of living forms brings order out of confusion, enabling us to see that increasing study and discovery may now lead to ever-widening generalisations, uniting the whole of the living kingdom under a system of natural and intelligible laws. Is it too much to say that, with such a vista before him, and the certainty that any observation he may conscientiously make will add to this grand conclusion, the young student of Biology has a tempting field before him, and a reasonable prospect of doing good work if he will only follow carefully in the footsteps of such patient investigators as Linnæus, Cuvier, and Darwin?

**Concluding Remarks.**—This short sketch gives but a very imperfect glimpse of the kind of work which is being done in science in our own days. The workers are now hundreds, where in the seventeenth century they might be reckoned by units, and the whole scope of their work cannot yet be measured. We can therefore, in conclusion, only try to understand the tendency of the science of our day as compared with that of earlier centuries.

The work of the sixteenth century, as we saw (p. 81), was to overcome that blind worship of authority which had sprung up during the Dark Ages, and which is the greatest enemy to true knowledge.

In the seventeenth century the march of scientific discovery began with Galileo, and advanced slowly but triumphantly through many dangers and difficulties till it culminated in the grand generalisations of Newton. This

was the first great era of modern science, especially of astronomy and physics, though Biology also made a great stride when Harvey demonstrated the circulation of the blood.

The eighteenth century continued the same work of patient inquiry, completing the harmony of astronomy by bringing the observed movements of the planets under Newton's law of gravitation; founding chemistry upon a firm basis of careful experiment; creating the sciences of zoology and botany, by establishing true systems of classification; discovering the hitherto almost unknown force of electricity; and reading in the crust of the earth the history of the past ages of our planet.

And so, when the nineteenth century opened, men found themselves with an immense mass of known facts and careful experiments, which had been accumulated during the last two centuries, and which were very difficult to deal with, because it had become almost impossible for any single mind to grasp them all. The scientific men of our century have therefore become divided into two great classes. On the one hand men have devoted themselves to special sciences, and even to special branches of a science, so that a man will often spend his whole life in the study of one department of chemistry or physics, or in investigating one little group of insects; and in this way discoveries of great value have been made.

On the other hand, great minds among us have taken up the separate facts collected by specialists, and have woven the whole of physical science into one grand scheme. Such men as Faraday, Sir W. Grove, Stokes, Helmholtz, Sir W. Thomson, and Clerk-Maxwell, together with many others, have done their part in this work, so that now all the various physical forces have been shown to be probably phases of one great force appearing under many forms. For the future

no one physical force can be studied as if it existed by itself alone, for each is shown to arise out of, and to pass into, others. Heat, electricity, magnetism, chemical affinity, motion—all are related to each other, and we cannot call any one of them the ruler over the rest. Like the colours on the soap-bubble, they each take their turn in appearing and disappearing, according to the conditions under which they arise. Their relations are almost infinitely complex, and we have still much to learn about them ; but the grand fact that they pass the one into the other has been demonstrated in our century ; and, under the names of ‘the conservation of energy,’ and ‘the correlation of the physical forces,’ is one of the greatest results of modern science.

The same tendency may be seen in the study of those sciences which relate to life. Here, again, modern investigation links together the scattered observations of ages, and unites them all in the theory of ‘evolution,’ or the gradual unfolding of nature ; a theory which has been worked out in all its details by Herbert Spencer, one of our greatest living thinkers. In astronomy, indeed, we already catch a glimpse of this law in the probable formation of the heavenly bodies out of gaseous star-matter ; and in the organic world we find it even more firmly held by scientific men in the belief that all the many forms of plant and animal life have been unfolded out of a few simple forms, just as the stem, the leaf, and the flower are evolved out of a simple seed.

We need not be too eager to force the truth of this theory upon unwilling minds, for the history of science teaches us that nothing but truth can stand the test of long investigation, while no power or authority can resist in the end that which is true. The imperfect theory of phlogiston did its work in gathering together many scattered facts in

chemistry, and then died a natural death when the discovery of oxygen threw more light upon the subject ; while no authority or persecution could suppress the true theory that the earth moves round the sun.

It is of great importance that we should all learn this lesson, to have faith in the invincible power of truth ; for it would almost seem as if all the experience of past centuries had hardly yet convinced us. We still, like the Aristotelians and the judges of the Inquisition, often make hasty and ignorant assertions, and try rather to prop up by authority that which we believe, than to inquire earnestly whether it is true. Yet every page in the history of Science teaches the contrary lesson. So much as is true in any belief will stand *because it is true* ; while that which is mistaken will fade away before earnest and impartial examination. Our part is to endeavour, like the great men of whom we have been reading, to open our eyes to the laws which surround us, and which are only hidden from us by our ignorance. And from whatever source we derive our knowledge, we must remember that it is very little after all, and be ready at all times to *examine* new facts, even though they may seem to upset some of our favourite opinions ; for unless we are so foolish as to think we know everything, it is certain that we shall often find that we have been mistaken.

Those who labour in this spirit of seeking the truth for itself will find their reward in the ever-increasing delight they will feel in studying God's works, and in the assurance which they will meet with at every step, that nothing can happen except under the guidance of His laws. True science, like true religion, leads to an entire and childlike dependence upon the Invisible Ruler of the Universe. It makes us eager to study the laws of the universe, that we may live in accordance with them, and diminish some of the

gross ignorance which now prevails with all its attendant evils; while at the same time it leads even the most instructed to feel how extremely limited our knowledge is, and that we are, after all, like inexperienced children, dependent upon the love and power of our Maker to bring us safely out of darkness into light.

CHRONOLOGICAL TABLES  
OF THE  
RISE AND PROGRESS OF THE VARIOUS  
BRANCHES OF SCIENCE.





SCIENCE OF THE GREEKS.

FROM B.C. 639 TO A.D. 200.

*The dates of this table refer to the years in which each particular step in advance was made; but up to the end of the Middle Ages they must be regarded as merely approximative.*

Astronomy.	Physics and Mechanics.	Chemistry.	Physical Geography and Geology.	Biology.
<p>B.C.</p> <p>600. Thales marks out solstices and equinoxes, p. 8.</p> <p>570. Anaximander—The sundial; the phases of the moon, p. 9.</p> <p>500. Pythagoras— The earth moves; morning and evening star the same, p. 11.</p> <p>450. Anaxagoras— Nature of sun and moon; eclipses; movements of the planets, p. 13.</p> <p>400. Democritus on Milky Way, p. 15.</p> <p>360. Eudoxus on movements of the planets, p. 15.</p> <p>357. Aristotle on occultation of Mars; asserts that the earth is round, p. 15.</p> <p>Ecliptic and Zodiac understood by the Greeks, p. 18.</p> <p>Aristarchus. Earth moves round the sun; obliquity of ecliptic; rotation of earth on its axis, p. 20.</p> <p>130. Hipparchus on precession of the equinoxes; calculates eclipses, p. 30.</p>	<p>500. Pythagoras invents the Monochord, p. 12.</p> <p>260. Euclid on light travelling in straight lines, p. 21.</p> <p>250. Archimedes on the lever; Hiero's crown and specific gravity; screw of Archimedes, pp. 22-25.</p> <p>120. Hero's engine, p. 244.</p>	<p>Greeks knew how to extract iron, mercury, and other metals from the ore; and make colours out of earths, p. 40.</p>	<p>570. Anaximander makes a map of the known world, p. 10.</p> <p>500. Pythagoras on changes of land and sea; on earthquakes, volcanoes, and petrifying springs, pp. 11-12.</p> <p>230. Eratosthenes lays down first parallel of latitude; measures circumference of the earth; studies mountain chains, pp. 27-29.</p>	<p>390. Hippocrates father of medicine; separates medicine from the priesthood, p. 14.</p> <p>341. Aristotle founder of zoology; studies the nature of plants and animals, p. 16.</p> <p>340. Theophrastus first botanist, p. 16.</p> <p>Erasistratus and Herophilus the first anatomists; they study brain, muscles, and nerves, p. 26.</p>
<p>A.D. 100-170. Ptolemy finds the Ptolemaic system, p. 32.</p>			<p>A.D. 100-170. Ptolemy on geography, p. 33.</p> <p>Strabo on earthquakes and volcanoes, p. 33.</p> <p>Pliny on natural history, p. 33.</p>	<p>A.D. 160. Galen, physician, studies nerves and arteries; works out a theory of medicine, p. 34.</p>

## SCIENCE OF THE MIDDLE OR DARK AGES.

FROM A.D. 700 TO 1500.

Astronomy.	Physics and Mechanics.	Chemistry.	Physical Geography and Geology.	Biology.
<p>The Arabs great astronomers, but mix up astronomy with astrology, p. 45.</p> <p>900. Albategnius calculates the length of the year, p. 45.</p> <p>1008. Ebn Junis draws up astronomical tables, p. 46.</p>	<p>(900. <i>Ben Musa on algebra and numerals.</i>)</p> <p>(1000. <i>Gerbert introduces Arabic numerals into Europe.</i>)</p> <p>1030. Alhazen on refraction of light; on atmospheric reflection; on magnifying glasses, pp. 46-50.</p> <p>1240. Roger Bacon and Vitellio on cause of the rainbow, p. 53.</p> <p>1302. Flavio Gioja invents the mariner's compass, p. 53.</p> <p>1455. Invention of printing, p. 54.</p> <p>1480. Leonardo da Vinci makes water-mills and river-locks, p. 58.</p>	<p>800. Marcus Græcus makes gunpowder, p. 42.</p> <p>Arabian alchemists; gases called 'spirit,' p. 41.</p> <p>860. Geber the founder of chemistry; distillation and sublimation; makes nitric and sulphuric acid; discovers that heating a metal adds to its weight, pp. 43-45.</p> <p>1240. Roger Bacon's experiments on air; he makes gunpowder; his 'Opus Majus' p. 52.</p>	<p>980. Avicenna, a famous writer on minerals, p. 49.</p> <p>1492. Columbus discovers America, p. 56.</p> <p>1497. Vasco di Gama sails round the Cape of Good Hope; sees the southern stars, p. 57.</p>	<p>Arabs learn medical science from Jews and Nestorians, p. 40.</p> <p>700 to 800. Medical schools of Bagdad and Salerno flourish, p. 40.</p> <p>Arabs devote themselves to medicine because dissection is forbidden by the Koran, p. 40.</p> <p>920. Medical school of Cordova founded, p. 40.</p> <p>1030 Alhazen on nature of sight; why we do not see double with two eyes, pp. 47-49.</p>

RISE OF MODERN SCIENCE.

FROM A.D. 1519 TO 1604.

Astronomy.	Physics and Mechanics.	Chemistry.	Physical Geography and Geology.	Biology.
<p>1543. Copernican system published, p. 64.</p> <p>1575. Tycho Brahe's observatory on Huen island; Tycho-nic system, p. 76.</p> <p>1576. Tycho in Bohemia, p. 76.</p> <p>1594. Kepler begins to study the planets, p. 93.</p> <p>1597. He joins Tycho in Bohemia, p. 93.</p> <p>1599. Rudolphine tables begun, p. 93.</p> <p>1600. Bruno burnt at the stake, p. 82.</p>	<p>1560. Baptiste Porta invents the camera obscura, p. 73.</p> <p>1580. Porta's engine, p. 246.</p> <p>1583. Galileo on the pendulum, p. 77.</p> <p>1589. On falling bodies, p. 78.</p> <p>— On musical sound, p. 80.</p> <p>1592. On motion of heavy bodies, p. 79.</p> <p>1592. Stevinus on statics, p. 80.</p> <p>1600. Kircher invents the magic lantern, p. 74.</p> <p>1600. Gilbert makes experiments on electricity, p. 75.</p>	<p>1530. Paracelsus, chemist and alchemist, separates out gold by means of aquafortis, p. 70.</p>	<p>1519. Magellan's ship sails round the world, p. 57.</p> <p>1565. Gesner on mineralogy and fossil shells, p. 68.</p> <p>1580. Palissy, the potter, insists that fossil shells were once real shells, p. 214.</p>	<p>1542. Vesalius refutes Galen; his anatomical drawings, p. 65.</p> <p>1548. Fallopius on anatomy, p. 66.</p> <p>1551. Gesner, first zoological cabinet and botanical garden, p. 67.</p> <p>1560. Eustachius. — Eustachian tube, p. 66.</p> <p>1560. Porta on structure of the eye, p. 74.</p> <p>1565. Gesner's 'History of Animals,' p. 67; His classification of plants, p. 68.</p> <p>1583. Cæsalpinus classifies plants by their flowers and seeds, p. 69.</p> <p>1603. Fabricius discovers valves in veins, p. 109.</p> <p>1604. Kepler on formation of images on the retina, p. 94.</p>

## PROGRESS OF MODERN SCIENCE.

FROM A.D. 1609 TO 1642.

Astronomy.	Physics and Mechanics.	Chemistry.	Physical Geography and Geology.	Biology.
<p>1609. Galileo discovers secondary light of the moon, Jupiter's moons; phases of Venus, pp. 87-90.</p> <p>1609. Kepler's two first laws, pp. 95-97.</p> <p>1611. Galileo observes sun-spots and proves rotation of sun on its axis, p. 90.</p> <p>1618. Kepler's third law, p. 98.</p> <p>1628. Kepler completes Rudolphine tables, and foretells transits of Venus and Mercury, p. 154.</p> <p>1631. Gassendi observes transit of Mercury, p. 154.</p> <p>1632. Galileo's system of the world; his recantation, p. 91.</p> <p>1639. Horrocks observes transit of Venus, p. 154.</p> <p>1642. Death of Galileo and birth of Newton, pp. 92-144.</p>	<p>1609. Invention of the telescope, p. 85; Galileo's telescope, p. 86.</p> <p>1611. Kepler's telescope, p. 94.</p> <p>1615. Solomon Caus' engine, p. 244.</p> <p>1620. Drebbel alcohol thermometer, p. 118.</p> <p>1620. Bacon's 'Novum Organum,' p. 101; Bacon suggests that heat may be a movement, p. 341.</p> <p>1621. Snellius discovers law of refraction, p. 104.</p> <p>1625. De Dominis explains the rainbow, p. 161.</p>	<p>1624. Van Helmont introduces the term gas, p. 71.</p>		<p>1619. Harvey discovers circulation of the blood, pp. 108-111</p> <p>1622. Asellius discovers lacteals, 112.</p>

PROGRESS OF MODERN SCIENCE.

FROM A.D. 1638 TO 1670.

Astronomy.	Physics and Mechanics.	Chemistry.	Physical Geography and Geology.	Biology.
<p>1659. Huyghens discovers Saturn's ring, and one satellite, p. 175.</p> <p>1666. Newton on method of fluxions; first idea of gravitation, pp. 145-150.</p>	<p>1638. Galileo on musical notes, p. 80.</p> <p>1644. Torricelli invents the barometer, p. 116.</p> <p>1646. Pascal proves the weight of air, p. 117.</p> <p>1650. Guericke invents the air-pump: Magdeburg hemispheres: first electrical machine, pp. 119-121.</p> <p>1658. Huyghens on cycloidal pendulums, p. 175.</p> <p>1661. Boyle's law of compression of gases, p. 126.</p> <p>1663. Marquis of Worcester's engine, p. 244.</p> <p>1666-1671. Newton on dispersion of light, proves its compound nature, pp. 161-166.</p> <p>1670. First mercurial thermometer, p. 118.</p>	<p>(1645. <i>First meetings of Royal Society</i>, p. 122.)</p> <p>(1662. <i>Académie des Sciences founded</i>, p. 124.)</p> <p>1665. Hooke on use of air in combustion, p. 128.</p> <p>1665. Boyle's experiments on air, p. 126.</p> <p>1670. Mayow discovers 'fire-air,' and shows it is used in burning, p. 129.</p> <p>1670. Beecher proposes theory, of 'phlogiston,' p. 132.</p>	<p>1669. Steno on fossils and petrifications, p. 214.</p> <p>1670. Scilla on fossils of Calabria, p. 214.</p>	<p>1647. Pecquet on the thoracic duct, p. 113.</p> <p>1649. Rüdbeck discovers lymphatics, p. 113.</p> <p>1656. Malpighi professor of medicine at Bologna, p. 135.</p> <p>1661. Malpighi uses microscope to examine air-cells of the lungs; discovers Malpighian layer: studies anatomy of insects, pp. 135-137.</p> <p>1663-1666. Journeys of Ray and Willughby, p. 139.</p> <p>1670. Mayow on respiration, p. 132.</p>

## PROGRESS OF MODERN SCIENCE.

FROM A.D. 1674 TO 1729.

Astronomy.	Physics and Mechanics.	Chemistry.	Physical Geography and Geology.	Biology.
<p>1676. Halley observes transit of Mercury, p. 154.</p> <p>1682. Newton works out and publishes the law of gravitation, pp. 147-152.</p> <p>1682. Halley foretells the return of a comet, p. 159.</p> <p>1687. Newton's 'Principia' published, p. 150.</p> <p>1691. Halley's method of measuring the sun's distance by the transit of Venus, p. 155.</p> <p>1722. Graham on shifting of magnetic needle, p. 368.</p> <p>1727. Bradley on nutation and aberration, p. 275.</p>	<p>1676. Roemer measures velocity of light, p. 172.</p> <p>1676. Noble and Pigot on stretched strings, p. 263.</p> <p>1678. Huyghens proposes undulatory theory of light; law of double refraction, pp. 175-179.</p> <p>1687. Newton on propagation of sound, p. 166.</p> <p>1690. Papin's heat-engine, p. 245.</p> <p>1698. Savery's heat-engine, p. 245.</p> <p>1700. Sauveur on musical vibrations, p. 263.</p> <p>Bernoulli, Euler, Lagrange on musical strings, p. 263, etc.</p> <p>1705. Newcomen's engine, p. 244.</p> <p>1729. C. More Hall on dispersion of light in flint and crown glass, p. 166.</p> <p>1732. Du Faye on electricity, p. 253.</p>	<p>1701. Boerhaave founder of organic chemistry, pp. 191-194.</p> <p>1718. Hales's experiments on gases, p. 225.</p> <p>1729. Stahl finds a system of chemistry on the theory of phlogiston, p. 133.</p>	<p>1682. Picart measures the size of the earth, p. 147.</p> <p>1695. Woodward on fossils and succession of formations in England, p. 215.</p>	<p>1674. Malpighi on structure of plants, p. 137.</p> <p>1677. Leeuwenhoeck discovers animalcules, p. 136.</p> <p>1682. Grew on structure of plants, p. 137.</p> <p>1690. Rivinus proposes to give two names to each plant, p. 208.</p> <p>1693. Ray and Willughby's classification of animals; Ray's system of plants, pp. 138-142.</p> <p>1694. Tournefort's system of plants, p. 142.</p> <p>1707. Buffon and Linnæus born, p. 203.</p> <p>1727. Hales on respiration of plants and formation of sap, p. 193.</p>

PROGRESS OF MODERN SCIENCE.

FROM A.D. 1738 TO 1767.

Astronomy.	Physics and Mechanics.	Chemistry.	Physical Geography and Geology.	Biology.
<p>1738. Bougier makes the first attempt to measure the earth's density, p. 288.</p>	<p>1840. Hawksbee's electrical machine, p. 121.</p> <p>1744. Celsius, Fahrenheit, and Reaumur mark off degrees on thermometer, p. 118.</p> <p>1746. Franklin's experiments in electricity, p. 253.</p> <p>1752. Franklin proves identity of electricity and lightning, p. 255.</p>	<p>1738. Bernouilli on molecules of gases, p. 462.</p> <p>1756. Black extracts 'fixed air' from limestone and examines it, p. 225.</p> <p>1761. Bergmann on chemical affinity and 'tests;' proves that fixed air is an acid, p. 227.</p>	<p>1740. Lazzaro Moro on the formation of the crust of the earth, p. 215.</p> <p>1749. Hutton begins to examine the formations of the earth's crust, p. 218.</p>	<p>1741. Linnæus' botanical garden at Upsala, p. 207.</p> <p>1743. Haller on contraction of the muscles; anatomical plates, p. 195.</p> <p>1748. Haller and Hunter on comparative anatomy, p. 196.</p> <p>1749. Buffon's 'Natural History;' distribution of animals, p. 204.</p> <p>1750. Daubenton's anatomy, p. 204.</p> <p>1753. Linnæus introduces specific names, p. 207.</p> <p>1754. Bonnet on leaves of plants, p. 200.</p>
<p>1761. Sun's distance first measured by the transit of Venus; Delisle's method introduced, pp. 155 and 276.</p>	<p>1757. Dollond's achromatic telescope, p. 166.</p> <p>1760. Black on latent heat in melting ice and in steam, p. 240.</p>	<p>1765. Watt's steam-engine, pp. 242-247.</p>	<p>1766. Cavendish discovers hydrogen, p. 229.</p>	<p>1762. Bonnet and Spallanzani on regrowth of severed limbs, p. 200.</p> <p>1764. Bonnet on development of animals, p. 202.</p>
<p>1764-1780. Lagrange, libration of the moon, p. 277.</p>	<p>1765. Watt's steam-engine, pp. 242-247.</p>	<p>1766. Cavendish discovers hydrogen, p. 229.</p>	<p>1767. Sprengel on fertilisation of plants, p. 400.</p>	<p>1767. Sprengel on fertilisation of plants, p. 400.</p>

## PROGRESS OF MODERN SCIENCE.

FROM A.D. 1766 TO 1789.

Astronomy.	Physics and Mechanics.	Chemistry.	Physical Geography and Geology.	Biology.
<p>1774. Maskelyne measures the earth's density by Schehallion experiment, p. 288.</p> <p>1774-1783. Laplace on long inequality of Jupiter and Saturn; moon's acceleration, pp. 277-280.</p> <p>1776. Lagrange proves the stability of the planetary orbits, p. 280.</p> <p>1781. Uranus discovered by Herschel, p. 281.</p> <p>1783. Proves the rotation of binary stars, p. 283.</p> <p>1786. He discovers star-clusters and nebulae, p. 284; and the motion of the solar system towards Hercules, p. 285.</p>	<p>1769. Boulton and Watt partners, p. 256.</p> <p>1785. Chladni on musical vibrations of solid bodies, p. 269.</p> <p>1785. Watt's double-acting steam-engine, p. 250.</p> <p>1789. Electricity experiments of Galvani; controversy between Volta and Galvani, pp. 257-262.</p>	<p>1772. Rutherford describes nitrogen, p. 234.</p> <p>1774. Priestley discovers oxygen, p. 230.</p> <p>1775. Scheele discovers oxygen, p. 230.</p> <p>1778. Lavoisier overthrows the theory of 'phlogiston' by proving the action of oxygen, p. 234.</p> <p>1779. Shows the composition of carbonic acid, p. 237.</p> <p>1784. Cavendish explodes oxygen and hydrogen, forming water, p. 230.</p> <p>1787. Lavoisier founds a new chemical nomenclature, p. 239.</p> <p>1789. Lavoisier's 'Elements of Chemistry' published, p. 238.</p>	<p>1766. Cook's voyage to the South Seas for the second transit measurement, p. 159.</p> <p>1775. Werner lectures on geology at Freyberg, p. 216.</p> <p>1784. Disputes between Neptunists and Vulcanists, p. 217.</p> <p>1785. Sir James Hall on melted rock; Hutton on granite veins, p. 221.</p> <p>1788. Hutton's 'Theory of the Earth' published, p. 218.</p>	<p>1768. Foundation of the Linnæan system; 'Systema Naturæ' completed, pp. 207-211.</p> <p>1772. Priestley on breathing of plants, p. 231.</p> <p>1778. Death of Linnæus; his collections brought to England, p. 211.</p> <p>1783. Hunter's museum begun in Leicester Square, p. 199.</p> <p>1789. Animal electricity discovered by Galvani, p. 257.</p> <p>1789. Jussieu founds the Natural System of plants, p. 397.</p>



PROGRESS OF MODERN SCIENCE.

FROM A.D. 1790 TO 1811.

Astronomy.	Physics and Mechanics.	Chemistry.	Physical Geography and Geology.	Biology.
1793. Herschel on cause of sun-spots, p. 367.	1792. Voltaic or chemical electricity, p. 259.	1794. Lavoisier guillotined, p. 238.	1790 Wm. Smith studies the succession of strata, p. 221.	1790. Goethe on the metamorphosis of plants, p. 398.
1799. Laplace's 'Mécannique Céleste,' p. 281.	1798. Rumford boils water by friction, p. 343.		1790. De Saussure studies the action of glaciers, p. 434.	
1801. Piazzi discovers Ceres, the first of the asteroids, p. 299.	1799. Davy melts ice by friction, p. 344.	1800. Nicholson and Carlisle, decomposition of water, p. 380.	1799. Humboldt's journeys in America. He traces isothermal lines, p. 408.	1800. Cuvier's lectures on anatomy; he insists on the fitness of organisation in individual animals, p. 412-422.
1802-4-7. Discovery of other asteroids. Olbers suggests they are fragments of a planet, p. 300.	1800. Voltaic pile, p. 261.	1800. Davy on laughing gas, p. 379.		1801. Lamarck on development of animals, p. 414.
1803. Biot on meteoric stones, p. 307.	1801. Ritter discovers chemical rays, p. 326.			1802. G. St.-Hilaire brings zoological collections from Egypt, p. 413.
	1801. Young on interference of light, p. 321.	1806. Davy on electrolysis; discovers potassium and sodium, p. 380.		1804. Humboldt on distribution of plants, p. 409.
	1802. Wedgwood and Davy, sun-pictures, p. 326.	1808. Dalton, law of multiple proportions; atomic theory, pp. 387-393.		
	1802. Wollaston lines of spectrum, p. 328.	1808. Gay Lussac on combination in multiple-volumes, p. 393.		
	1804. Fraunhofer compares lines in the spectrum of sun and stars, p. 330.	1811. Avogadro on molecular composition of gases, p. 393.		
	1808. Malus discovers polarization of light by reflection, p. 318.			
	1811. Leslie and Melloni on heat rays, p. 351.			

## PROGRESS OF MODERN SCIENCE.

FROM A.D. 1812 TO 1848.

Astronomy.	Physics and Mechanics.	Chemistry.	Physical Geography and Geology.	Biology.
	<p>1815. Davy's safety-lamp, p. 379.</p> <p>1816. Fresnel and Young, polarization of light, p. 321.</p>		<p>1812. Former periods of life on the globe proved by Cuvier, p. 420.</p> <p>1815. W. Smith's geological map, p. 221.</p> <p>1817. Buckland's geological lectures, p. 427.</p>	<p>1812. Cuvier restores the fossil animals of Paris, p. 420.</p>
<p>1819. Encke's Comet, p. 300.</p> <p>1820-1838. Sir J. Herschel studies stars of the southern hemisphere; Magellanic clouds, p. 305.</p>	<p>1819. Oersted, electro-magnetism, p. 356.</p> <p>1820. Ampère, electro-magnetism, p. 359.</p> <p>1821. Faraday, electro-magnetism, p. 364.</p> <p>1822. Seebeck on thermo-electricity, p. 365.</p>	<p>1818. Berzelius on use of the blow-pipe, p. 386.</p>		<p>1817. Cuvier's 'Animal Kingdom' published, p. 418.</p> <p>1818. G. St.-Hilaire on unity of plan in animals, p. 416.</p>
<p>1826-60. Schwabe proves periodicity of sun-spots, p. 367.</p> <p>1826. Biela's comet, p. 301.</p>	<p>1826. Nobili proves the truth of animal electricity, p. 259.</p>	<p>1822. Herschel on use of spectroscope to detect chemical elements, p. 331.</p> <p>1823. Liquefaction of gases by Faraday, p. 464.</p>	<p>1825. McEnery discovers flint tools, with bones of extinct animals, in Kent's Cavern, p. 438.</p>	<p>1828. Von Baer's law of embryological development, p. 422.</p>
<p>1838. Herschel's 'Outlines of Astronomy' published, p. 305.</p>	<p>1837. Wheatstone and Cooke electric telegraph, p. 370.</p>	<p>1830. Liebig's analyses of organic substances, p. 393.</p> <p>1832. Discovery of chloroform and chlorale by Liebig, p. 395.</p> <p>1834. Faraday on electrolysis; chemical nature of electric current; invention of voltameter, p. 380.</p>	<p>1830. Lyell's 'Geology'; he insists on sufficiency of causes like the present to explain the past history of the globe, p. 427.</p>	<p>1830. Robert Brown, Moldenhauer, Mirbel, and others, on structural and physiological botany, p. 402-406.</p> <p>1832. Death of Cuvier, p. 422.</p> <p>1839. Agassiz on freshwater fishes, p. 432.</p>
	<p>1839-42. Séguin and Mayer on relation between heat and work, p. 347.</p> <p>1839. Daguerreotypes, p. 327.</p>		<p>1840. Agassiz on glacial period and blocks carried over Europe by ice, p. 433.</p>	<p>1840-48. Organic chemistry, p. 393.</p> <p>1835. Sir W. Hooker, and foundation of Kew Gardens, p. 406.</p>

RISE OF MODERN SCIENCE.

FROM A.D. 1843 TO 1879.

Astronomy.	Physics and Mechanics.	Chemistry.	Physical Geography and Geology.	Biology.
<p>1845. Division of Biela's comet, p. 301.                      1845-6. Adams and Leverrier work out the position of Neptune; Galle finds the planet, p. 302-304.                      1850. Lamont, periodicity of magnetic disturbance, p. 368.                      1859. Carrington and Hodgson, sun-spot and magnetic disturbance, p. 369.                      1859. Lescarbault sees intra-mercurial planet, p. 458.</p>	<p>1843-49. Joule on equivalent of heat; dynamical theory of heat, p. 346.                      —Hirn's experiments on heat, p. 350.                      1847. Helmholtz, conservation of energy, p. 352.                      1850. Foucault and Fizeau on velocity of light, p. 323.                      18—. Clerk-Maxwell and others on molecular theory of gases. Helmholtz and Sir W. Thomson on vibrations of molecules, p. 463.                      1852. Thomson, Sir W., dissipation of energy, p. 353.                      1860-1866. Four new metals discovered by spectrum analysis, p. 333.                      1861. Bunsen and Kirchhoff discover the meaning of the lines in the spectrum, p. 333.                      1862. Huggins and Miller, spectrum analysis of the stars and nebulae, p. 338.                      —Alexander Herschel, spectrum of falling stars, p. 340.                      1872. Graham Bell, the telephone, p. 375.                      1878. Abney on photography at the red end of the spectrum, p. 328.</p>	<p>1848. Wöhler makes organic elements artificially, p. 393.                      1850 <i>et seq.</i> Advances in chemistry of organic compounds, p. 468.                      1861. Metals in the atmosphere of the sun and stars discovered by spectrum analysis, p. 336.                      1862. Andrews on critical points in gases, p. 465.</p>	<p>1847. Boucher de Perthes discovers flint implements at Abbeville, p. 437.                      1853. Discovery of Swiss lake-dwellings, p. 439.                      1858. Humboldt's 'Cosmos' published; death of Humboldt, p. 408.                      1863. Lyell's 'Antiquity of Man,' p. 440.</p>	<p>1840. Nägeli, Sachs and others on structural botany, p. 469.                      1853. Von Mohl on protoplasm, p. 405.                      1858. Theory of natural selection by Darwin and Wallace, p. 448.                      1859. Darwin's 'Origin of Species,' p. 448.                      —Structure of carnivorous plants, p. 469</p>
<p>1862-66. Schiaparelli, Adams, and Leverrier, discover the orbits of comets and meteor systems, p. 308.                      1862. Travelling stars studied by the spectroscope, p. 459.                      1874. Expeditions to observe the transit of Venus, p. 159.                      1875. Leverrier's analysis of the orbits of the planets, p. 459.                      1877. Discovery of satellites of Mars, by Asaph Hall, p. 457.                      1878. Watson sees two intra-mercurial planets, p. 458.</p>	<p>1861. Bunsen and Kirchhoff discover the meaning of the lines in the spectrum, p. 333.                      1862. Huggins and Miller, spectrum analysis of the stars and nebulae, p. 338.                      —Alexander Herschel, spectrum of falling stars, p. 340.                      1872. Graham Bell, the telephone, p. 375.                      1878. Abney on photography at the red end of the spectrum, p. 328.</p>	<p>1877-78. Pictet and Cailletet liquefy the permanent gases, p. 465.                      1879. Crookes on ultra-gaseous state of matter, p. 466.</p>	<p>1852-72. Discovery of intermediate fossil forms, p. 473.</p>	<p>1860-79. Advance in our knowledge of fertilisation of plants, p. 470.                      1878. Professor Marsh's discoveries of gigantic fossil forms in America, p. 473.</p>

# ABRIDGED CHRONOLOGICAL TABLE OF SOME OF THE CHIEF MEN OF SCIENCE

*From the Time of the Greeks to the MIDDLE of the Nineteenth Century.*

	Astronomy.	Physics and Mechanics.	Chemistry.	Physical Geography and Geology.	Biology.
Greeks.	Thales, Anaximander; Pythagoras; Anaxagoras; Democritus; Eudoxus; Aristotle; Aristarchus; Hipparchus; Ptolemy.	Euclid. Archimedes.		Anaximander. Pythagoras. Eratosthenes. Ptolemy Strabo.	Hippocrates; Aristotle; Theophrastus; Erastriatus; Herophilus; Galen.
Middle Ages.	Albategnius. Ebn Junis.	Gerbert; Ben Musa; Alhazen; Roger Bacon; Vitello; Flavio Gioja; Leonardo da Vinci.	Marcus Græcus. Geber. Roger Bacon.	Avicenna. Columbus. Vasco di Gama. Magellan.	<i>Arabian medical schools famous</i>
Sixteenth Century.	Copernicus. Tycho Brahe. Giordano Bruno.	Baptiste Porta; Gilbert; Galileo; Stevinus.	Paracelsus. Van Helmont.	Gesner. Palissy.	Vesalius; Fallopius; Eustachius; Gesner; Cæsalpinus; Fabricius.
Seventeenth Century.	Galileo; Kepler; Gasendi; Horrocks; Newton; Huyghens; Halley.	Snellius; Descartes; Bacon; Drebbel; Torricelli; Guericke; Boyle; Hooke; Huyghens; Roemer.	Mayow. Beecher. Stahl.	Steno. Scilla. Woodward.	Harvey; Asellius; Rüdbeck; Malpighi; Leewenhoeck; Grew; Ray; Willughby; Tournefort.
Eighteenth Century.	Bradley; Delisle; Lagrange; Laplace; Herschel; Maskelyne.	Du Faye; Celsius; Fahrenheit; Reaumur; Watt; Franklin; Galvani; Volta; Rumford; Sauvour; Bernoulli; Chladni.	Boerhaave; Hales; Black; Bergmann; Cavendish; Priestley; Scheele; Rutherford; Lavoistier.	Lazzaro Moro. Werner. Hutton. William Smith. De Saussure.	Boerhaave; Hales; Haller; Hunter; Bonnet; Spallanzani; Buffon; Daubenton; Linnæus; Jussieu; Sprengel.
Nineteenth Century.	Piazzi; Olbers; Encke; Gauss; Sir J. Herschel; Airy; Adams; Leverrier; Galle; Schwabe; Schiaparelli; Secchi; Piazzi Smyth.	Young; Malus; Fresnel; Arago; Oersted; Ampère; Seebeck; Brewster; Sabine; Fraunhofer; Kirchhoff; Huggins; Mayer; Joule; Wheatstone; Sir W. Thomson; Helmholtz; Weber; Clerk-Maxwell; Tyndall; J. a. t.	Wollaston; Berzelius; Biot; Dalton; Thomson; Gay-Lussac; Davy; Faraday; Liebig; Wöhler; Bunsen; Miller; Graham; Andrews; Avogadro; Berzelius; St. Claire-Deville.	Humboldt. Buckland. Lyell. Agassiz. Murchison. Sedgwick. Von Buch.	Lamarck; Goethe; G. St. Hilaire; Cuvier; Von Baer; Boucher de Perthes; Darwin; Wallace; Agassiz; Auguste de Candolle; R. Brown; Von Mohl; Sir W. Hooker; Owen; Huxley; Parker; Balfour; Hæckel; Gegenbaur.

# INDEX

## ABBEVILLE

- A**BBEVILLE flint implements, 438  
 Aberration of fixed stars, 275  
 Abney, Capt., on chemical rays of light, 328  
 Academies of science founded, 124  
 'Academy of Secrets' at Naples, 73  
 Achromatic telescopes, 166  
 Acids, strong, discovered by Geber, 44  
 Acoustics, Newton on, 166; Chladni on, 269  
 Adams calculates the position of Neptune, 300; on November meteors, 308  
 Æsculapius, god of medicine, 14  
 Aerial acid, Bergmann on, 228  
 Agassiz, his history, 432; on glacial period, 433  
 Aigle, meteoric stone-fall at, 307  
 Air, Boyle and Hooke, experiment on, 128; Mayow on, 129; -cells studied by Malpighi, 138; -pump, section of, 119; -tubes of insects, 136  
 Airy, Adam's paper on Neptune sent to, 303.  
 Albategnius calculates length of year, 45  
 Albinus, anatomical drawings of, 196  
 Alchemists, Arabian, 40  
 Aldebaran, spectrum of, 339  
 Alexandria, founding of the city of, 18; school of learning at, 18; taken by the Arabs, 39; Egyptian animals preserved at, 413  
 Algebra, an Arabian name, 46  
 Alhazen on eyesight, 46; on refraction, 47; on atmospheric refraction, 48; on magnifying power of lenses, 49  
 Alps, glaciers of the, 434  
 Amazons, closely related butterflies of the, 442  
 Amber, electric nature of, 74  
 America, glaciation of, 436  
 Ammonia, origin of name, 45  
 Ampère, early life of, 357; on direction of magnetic current, 359; on electro-magnets, 361; invents the galvanometer, 365; on cause of terrestrial magnetism, 365; suggests electric telegraph, 370; on pressure of gases, 393

## ARAGO

- Analysis, term explained, 387; of substances by tests, 385; Spectrum-, 333, 386  
 Anatomy, Erasistratus and Herophilus on, 26; Vesalius on, 65; Eustachius and Fallopius on, 66; vegetable-, 138; rise of comparative, 197; Haller and Hunter on, 197; Cuvier on, 418  
 Anatomical plates of Vesalius, 65; of Haller, 196  
 Anaxagoras on the moon and on eclipses, 13; banished, 14  
 Anaximander, science of, 9  
 Anderson brings Newcomen engine to Watt, 244  
 Andrews on critical point of gases, 465  
 Angström on the solar spectrum, 338  
 Animal electricity, 257  
 Animalcules, discovery of, 136  
 Animals, Cuvier on internal structure of, 416; fossil, restored by Cuvier, 420; Lamarck on development of, 414; facts proving development of, 442, etc.; gradual succession of, on the globe, 444; selection of, by man, 450; natural selection of, 450; fossil, intermediate forms of, 445.  
 Animals and plants, Aristotle on links between, 16; history of, by Gesner, 67; classified by Ray and Willughby, 140; Linnæus gives specific names to, 209; Buffon on distribution of, 205; Grew and Malpighi on, 134-138; Darwin and Wallace on, 448.  
 Antiquity of man, 437; Lyell's work on, 440  
 Aphides, Bonnet on, 200  
 Apollo or Helios, god of the sun, 17  
 Apple, Newton and the, 146; -leaf, skin of, showing stomates, 138  
 Aqueous rocks, Hutton on, 218  
 Arabs, conquests of the, 39; science of the, 40; chemistry of the, 40; gunpowder known to the, 42; medical schools of the, 40  
 Arago on polarization of light, 321; on electro-magnetism, 361; on Biela's comet, 301

## ARCHIMEDES

- Archimedes on the lever, 22; on Hiero's crown and specific gravity, 22; screw of, 25; killed in the Punic war, 25
- Areas described by planets about their centre, 97
- Aristarchus taught that the earth moves round the sun, 20; discovered obliquity of ecliptic, 21; and rotation of the earth on its axis, 21
- Aristotelians, dogmatism of the, 78, 103
- Aristotle on astronomy and zoology, 15, 16; on development of animals, 441
- Arteries, passage of blood in, 109; throbbing of, explained, 110
- Asellius on lacteals and nourishing fluid, 112
- Astatic needle of the telegraph, 373
- Asteroids, or minor planets, 299
- Astrology of the Arabs, 45
- Astronomy, definition of, 2; of Thales, 8; of Anaximander, 9; of Anaxagoras, 13; of Aristotle, 15; of Aristarchus, 20; of Hipparchus, 29; of Ptolemy, 32; of Albategnius, 45; of Ebn Junis, 45; of seventeenth century, 182; of eighteenth century, 275; of nineteenth century, 298; recent advances in, 456
- Atmosphere, refraction of sun's rays in the, 48; varying weight of the, 116; pressure of the, 120
- Atomic theory, 390
- Atoms, definition of term, 390; of all the planets attract each other, 148
- Attraction, by electricity, 75, 122; of gravitation decreases with square of the distance, 150
- Aurora borealis coincident with outbreak of a sun-spot, 369
- Australia, fossil and living pouched animals of, 444
- Authority valued more than truth in the Dark Ages, 103
- Avicenna on minerals, 49
- Avogadro on gases, 393
- BACON**, Roger, his 'Opus Majus,' 52
- Bacon, Francis, his influence on science, 101; on heat, 341
- Baer. See Von Baer,
- Bagdad, medical school of, 40
- Bain's telegraph, 374
- Balloons, hydrogen used for filling, 230
- Banks, Sir J., his museum, 403
- Barometer, invention of the, 114, 117
- Bartholinus, on double refraction in Iceland spar, 179
- Bary, de, cited, 471
- Basalt, disputes about formation of, 217-220
- Bates on species of Amazon insects, 442
- Battery, first electric, 260
- Becher proposes theory of Phlogiston, 133
- Becquerel cited, 366

## BROUGHAM

- Beehive, star-cluster called the, 284
- Bees, clover fertilised by, 451
- Bell on the telephone, 376
- Bells, cause of musical sound in, 272
- Ben Musa, Arabian mathematician, 45
- Bergmann on chemical affinity, 227; on 'fixed air,' 228
- Bernoulli, on gases, 462; on stretched strings, 263
- Berzelius—His discoveries by electrolysis, 382; on use of blowpipe, 386
- Betelgeux, no hydrogen in light of, 339
- Biela's comet, 301
- Binary stars, Herschel discovers, 284
- Biology, definition of, 2; of seventeenth century, 185; spread of in eighteenth century, 190
- Biot on meteoric stone-fall, 307; on polarization, 323
- Birds, Ray and Willughby on, 138; rapid multiplication of, 449
- Black discovers 'fixed air,' 225; on latent heat, 240
- Blood, circulation of the, 109-111; earlier theories about, 108; air-bubbles drawn out of the, 132
- Blowpipe, Berzelius on use of, 386
- Blumenbach cited, 396
- Bode's law, 299
- Boerhaave, his character and influence, 191; on organic chemistry, 192; on juices of plants, 192; on fluids of animals, 194; his death, 194
- Bonnet's experiments on aphides and plants, 200; on regrowth of severed limbs, 200; on development of animals, 202
- Bornet, Professor, cited, 473
- Botanical garden of Gesner, 67.
- Botanist, Theophrastus the first, 16
- Botany, different kinds of, 2; writers on, 17, 68, 69, 141, 207, 396; recent advances in, 470
- Boucher de Perthes finds ancient flint implements, 437
- Bougier measures the density of the earth, 288
- Boulton, partner of Watt, 250
- Boyle one of the founders of Royal Society, 123; his air-pump, 126; his law of compressibility of gases, 117; his experiments on air, 128
- Bradley on aberration and nutation, 275
- Brain described by Erasistratus, 26
- Breathing, Mayow on, 131
- Brewster, Sir D., on polarization, 323; on spectrum analysis, 333
- British Museum, meteoric stones in the, 307
- Bronze tools of lake-dwellings, 439
- Brougham, Lord, his article against Young, 320

## BROWN

- Brown, Robert, on structural botany, 402  
 Bruno burnt at the stake, 81  
 Buckland, his Cambridge lectures, 427; on glaciation of Wales, 436  
 Buffon, history of, 203; his work on natural history, 204; patronises Lamarck, 412  
 Bunsen on dark lines in solar spectrum, 333
- CÆSALPINUS** on plants, 69; on circulation of the blood, 109  
 Cæsium discovered, 333  
 Cailletet, M., liquefies permanent gases, 466  
 Cairo, medical school of, 40  
 Caloric, old term for heat, 342  
 Camera obscura, invention of the, 73  
 Candolle, Auguste de, on metamorphosis of plants, 400  
 Capillaries discovered by Malpighi, 135  
 Carbonic acid obtained by Black, 225; tested by Bergmann, 228; its nature discovered by Lavoisier, 237  
 Carlisle on decomposition of water by electricity, 380  
 Carnivorous plants, 471.  
 Carnot on heat converted into motion, 350  
 Carrington, Mr., on outbreak of a sun-spot, 369  
 Cassini on velocity of light, 173  
 Catastrophists in geology, 427  
 Cats, their indirect influence on growth of clover, 451  
 Caus' engine, 244  
 Cavendish discovers hydrogen, 229; on composition of water, 230; his experiment on weight of the earth, 289  
 Caxton the printer, 55  
 Cellular tissue, section of, 137  
 Celsius invents centigrade scale, 118  
 Centigrade scale, 118  
 Ceres discovered by Piazzi, 299  
 Charles II. grants Royal Society charter, 123; V. of Spain protects Vesalius, 66  
 Chemical rays discovered, 326; action of, in photography, 326, 328; nomenclature of Lavoisier, 238; elements, weight of, 389; symbols, 392: theory of electricity, 382  
 Chemical affinity, Bergmann on, 227; Newton on, 227; power of electric current to overcome, 383  
 Chemistry, definition of, 2; of the Arabs, 41; of Geber, 43; of Paracelsus and Van Helmont, 70: of Boyle and Hooke, 128; of Mayow, 129; Boerhaave on organic, 192; of Black, 225; of Bergmann, 227; of Cavendish, 229; of Priestley, 230; Newton's work on, destroyed, 169; methods of studying, 385; recent advances in organic, 469

## COSMOS

- Chick, Harvey on development of, 112  
 Chinese, early science of, 4; mariner's compass known to the, 54  
 Chladni on musical vibrations, 269; his musical sand figures, 273  
 Chorale, discovery of, 395  
 Chloroform, discovery of, 395  
 Chromosphere of the sun, 337  
 Cinnamon tree, essences obtained from, 192  
 Cipher, word derived from Arabic, 46  
 Circulation of the blood, diagram of, 111  
 Circular polarization in quartz crystals, 323  
 Circumference of earth measured by Eratosthenes, 27  
 Classifications of plants, 69, 140, 207; of animals, 67, 140, 207, 418  
 Clausen calculates the period of Biela's comet, 301  
 Clausius on diffusions of gases, 463  
 Clerk-Maxwell on molecular theory of gases, 463; on electro-magnetism, 464  
 Clifford, Mr., befriends Linnæus, 206  
 Climate, Humboldt on causes of, 409; Lamarck on effects of, 415  
 Cod-fish, animalcules in roe of, 136  
 College of Surgeons, Hunter's collection in, 198  
 Colouring matters, 469  
 Colours, prismatic, 162; cause of, in telescopes, 166; caused by interference of light, 316; on the soap-bubble, 317; depend on light-vibrations, 177  
 Columbus, Christopher, his voyages, 56; discovers variation of magnetic needle, 57  
 Columbus on circulation of the blood, 108  
 Combustion, Hooke on, 128; Mayow on, 129; Stahl's theory of, 133; cause of, proved by Lavoisier, 237  
 Comet, Halley predicts return of, 159  
 Comets, Newton on orbits of, 151; returning, 301; and meteors, 306  
 Commutator of the Telegraph, 373  
 Comparative anatomy, rise of, 197; Hunter's collection illustrating, 198; Haller on, 196; Cuvier on, 417  
 Compass, figure of first mariner's, 54  
 Compound flowers, 142  
 Condenser, Watt's separate, 247  
 Conservation of energy, 350  
 Contraction of the muscles, 197  
 Cook's voyage to observe transit of Venus, 159  
 Cooke patents electric telegraph, 370  
 Copernican theory, 64; proofs of the truth of, 88  
 Copernicus, life and work of, 63  
 Cope, Professor, cited, 475  
 Cordova, medical school of, 40  
 Corpuscular theory of light, 174, 312  
 Correlation of the physical forces, 476  
 'Cosmos' of Humboldt, 408

## CRABTREE

- Crabtree sees transit of Venus, 154  
 Critical point of gases, 465  
 Crookes discovers thallium, 333; on ultra-gaseous state of matter, 467  
 Crown of cups, Volta's, 260  
 Crown-glass, dispersion of light in, 166  
 Crystals, double refraction in, 179; passage of light-waves in, 322; circular polarization in quartz, 323  
 Currents, from an electric battery, 261; Humboldt on ocean, 409  
 Curtis, Dr., on carnivorous plants, 471  
 Cuvier, history of, 412; on creation of animals, 416; on comparative anatomy, 417; on fossil animals of Paris, 420; death of, 422  
 Cycloidal pendulums, 175
- D**ABURON, Ampère's visit to, 358  
 Daguerre fixes sun-pictures, 327  
 Dalton, life of, 387; law of multiple proportions, 390; atomic theory, 390  
 Dark ages, science of, 39 *et seq.*  
 Darwin, 447; on origin of species, 448; on causes of natural selection, 451  
 Daubenton's anatomical work, 204  
 Davy, Sir H., his history, 378; his experiments on nitrous oxide, 379; on electrolysis, 380; discovers potassium and sodium, 381; his safety lamp, 379; on sun-pictures, 326; melts ice by friction, 344  
 De Dominis on the rainbow, 161  
 De la Rue cited, 338  
 Delisle's method of measuring transit of Venus, 276  
 Deltas, growth of, 12  
 Democritus on the Milky Way, 15  
 Denudation, Hutton on, 218  
 Descartes on light, 104, 161; on the value of doubt, 103  
 Development of animals, Lamarck on, 414; Von Baer on, 424  
 Diagram showing how distances can be measured on the sun's face, 157  
 Diagrams of bent and broken rocks, 216, 217  
 Diameter of the sun, 158  
 Diamond, nature of, proved by Lavoisier, 237  
 Djafer, or Geber, Arabian alchemist, 43  
 Diæcious plants explained by Cæsalpinus, 70  
 Dicotyledons, term explained, 141  
 Differential calculus, by Leibnitz, 145  
 Disc, Newton's rotating, 165  
 Dispersion of light discovered by Newton, 161; in different kinds of glass, 166  
 Dissipation of Energy, 353  
 Distillation known to Geber, 43  
 Distribution of animals, Buffon, 205; of plants, Humboldt on, 409

## ENCKE

- Dogmatism of the sixteenth century, 64, 78, 81  
 Döllinger, anatomist, 423  
 Dollond, Mr., makes achromatic telescope, 166  
 Dopler, on movements of stars, 459  
 Double refraction, 179  
 Doubt, Descartes on the value of, 103  
 Drebbel makes alcohol thermometer, 118  
 Ducts of plants, 137  
 Du Faye on electricity, 253  
 Dynamical theory of heat, 349
- E**ARL'S COURT, Hunter kept wild animals at, 198  
 Earth declared by Aristotle to be a globe, 16; circumference of, measured, 28; Picart measures the size of the, 147; Newton on shape of the, 151; measurement of density of the, 287  
 Earth-light on the moon, 88  
 Earthquakes, Pythagoras on, 12; Strabo on causes of, 33; changes of level caused by, 430  
 Ebn Junis, Arabian astronomer, 45  
 Eclipses explained by Anaxagoras, 13  
 Ecliptic or sun's path, how traced out by the Greeks, 18; Anaxagoras discovers obliquity of, 21  
 Egyptians, early science of, 4  
 Eighteenth century, work of the, 474; summary of science of, 289  
 Elective affinities, Bergmann on, 227  
 Electric currents causing magnetic field, 358; making electro-magnets, 360; power of to conquer chemical affinity, 382  
 Electrical machines, Guericke's, 121; Hawksbee's, 121  
 Electric spark observed by Guericke, 122  
 Electric telegraph, invention of, 370; Bain's set on fire by magnetic storm, 356; Morse's and Steinheil's, 371; Bain's and Cowper's, 374  
 Electricity, Gilbert on, 74, 121; attraction and repulsion by, 122; Du Faye on different kinds of, 253; Franklin on, 254; and lightning, 255; animal, 257; chemical or voltaic, 259; chemical theory of, 382; produced by heat, 365.  
 Electrolysis, discovery of, 380  
 Electro-magnetism, Oersted discovers, 356; Ampère on, 359; Faraday on, 364  
 Electro-magnets made by electric current, 360  
 'Electron,' root of word 'electricity, 75  
 Ellipses, planets move in, 96  
 Embryology, Von Baer's law of, 422  
 Embryos of animals alike in structure, 42  
 Emission theory of light, 174, 312  
 Encke's comet, 300



## ENERGY

- Energy, potential and active, 349; conservation of, 350; dissipation of, 352  
Engines, history of, 244; the Newcomen, 245; Watt's double-acting, 249  
England, geological map of, by W. Smith, 222  
Epicycles, theory of, 64  
Epidermis studied by Malpighi, 136  
Equinoxes observed by Thales, 9; Hipparchus discovers precession of, 30  
Erasistratus on the brain, 26  
Erratic blocks on the Jura, 435; a proof of former extension of ice, 436  
Eratosthenes lays down first parallel of latitude, 27; measures circumference of the earth, 28  
Ether, light a vibration of the, 176  
Euclid, some problems of, invented by Thales, 9  
Euclid discovers that light travels in straight lines, 21  
Eudoxus explains movements of the planets, 15  
Euler on sound, 263  
Eustachius the anatomist, 66  
Evolution, theory of, 441  
Extinct animals restored by Cuvier, 420; man contemporary with, 437  
Eye, Alhazen on the sight of the, 46; Porta on structure of the, 74; Kepler on the, 94

## FABRICIUS Aquapendente discovers valves in veins, 109

- Fahrenheit thermometer, freezing-point of, 118  
Falling bodies, Galileo on rate of, 78  
Fallopian, the anatomist, 66  
Faraday, history of, 361; on rotation of magnets and electric wires, 363; on electric current produced by a magnet, 364; on connection between electricity and chemical changes, 362; on liquefaction of gases, 465  
Faust, John, the printer, 55  
Fire-air discovered by Mayow, 129; its effect on the blood, 132  
'Fixed air,' Black on, 225; Bergmann tests, 227  
Fizeau on velocity of light, 323  
Flame, spectra of different kinds of, 331  
Flint implements of Abbeville, 437  
Flint-glass, dispersion of light in, 166  
Flood, attempt to explain fossils by a universal, 214  
Fluxions, Newton's method of, 145, 150  
Forces, convertibility of, 385; of gravitation, 146  
Fossil animals restored by Cuvier, 420; intermediate forms of, 445; found in Rocky Mountains, 475

## GERANIUM

- Fossil shells observed by Pythagoras, 11  
Fossils, Gesner on, 68; first attempts to explain, 214; used by W. Smith for classification, 222  
Foucault on velocity of light, 323  
Frankland, Dr., cited, 469  
Franklin's early life, 252; he proves lightning to be electricity, 255  
Fraunhofer's early life, 329; lines, 330  
French school of chemistry, 238  
Fresnel, history of, 320, on polarization of light, 320; on circular polarization, 322  
Freyberg, Werner's lectures at, 216  
Friction, ice melted and water boiled by, 344  
Friendship of Ray and Willughby, 139  
Frog's leg, electricity in, 259
- G**ALLEN, physiology of, 34; corrected by Vesalius, 65  
Galileo on the pendulum, and on falling bodies, 77; on musical notes, 80; on secondary light of the moon, 87; on Jupiter's moons, 88; on phases of Venus, 89; on sun-spots and rotation of sun on its axis, 90; demonstrates the truth of Copernican theory, 89, 92; his telescope, 87; his recantation, 91; on rising of water in a pump, 114; makes a water thermometer, 118; compared with Tycho and Kepler, 100  
Galle finds Neptune, 304  
Gallium discovered, 333  
Galvani on animal electricity, 257; his controversy with Volta, 259  
Galvanism, 258  
Galvanometer invented by Ampère, 365  
Ganges, mud carried down by the, 429  
'Gas,' term used by Van Helmont, 71; Nebulæ composed of,  
Gases, Boyle's law of, 126; Bacon on, 52; Mayow on, 129; discovery of the four important, 225; spectra of, 332; atmosphere of, round the sun, 337; diffusion of, 463; critical point of, 465; liquefaction of, 465; molecular theory of, 463  
Gassendi observes transit of Mercury, 154  
Gauss re-discovers Ceres, 299  
Gay-Lussac on multiple volumes, 393  
Geber the founder of chemistry, 43-45  
Geist, word 'gas' derived from, 71  
Geography, Ptolemy's work on, 33; Strabo on, 33  
Geology, definition of, 2; of Pythagoras, 11; neglected in dark ages, 213; Lazzaro Moro on, 215; Werner on, 216; Hutton on, 218; W. Smith on, 221; Sir C. Lyell on, 427; prejudices retarding, 426  
George II. founds Göttingen University, 195  
Geranium, Linnæus's definition of the, 208

## GERBERT

- Gerbert introduces Arabic numerals into Europe, 46  
 Germany, Imperial Academy in, 124  
 Gesner, his cabinet and garden, 67; his history of animals, 67; his botanical classification, 68  
 Gilbert, first experiments on electricity, 74  
 Gioja discovers mariner's compass, 53  
 Glacial period, 433  
 Glacier, illustration of a, 434; carrying blocks to the Jura, 435  
 Gladstone, Dr., his life of Faraday, 361  
 Glass, angle of polarization of light from, 319; index of refraction for, 106; different dispersive powers of, 166  
 Glasses, musical, 272  
 Glen Tilt, granite veins in, 221  
 Gnomon at Alexandria, 28  
 Goethe on metamorphosis of plants, 398; on discussion between Cuvier and St. Hilaire, 417  
 Gold separated from amalgam by Paracelsus, 70  
 Göttingen University founded, 195  
 Graebe cited, 469  
 Graham, Dr., on diffusion of gases, 463  
 Graham on variations of magnetic needle, 368  
 Granite, Hutton on formation of, 220; veins in Glen Tilt, 220  
 Gravitation, law of, explained, 145-150; discovered by Newton, 147; its action on the planets, 149; decreases with the square of the distance, 150; problems explained by, 151; holding distant stars together, 284  
 Græcus, Marcus, discovers gunpowder, 42  
 Gratz, Kepler professor at, 93  
 Greece, Roman conquest of, 35  
 Greek colonies in Ionia, 8  
 Greeks deficient in natural knowledge, 8; believed the sun moved round the earth, 19; knew electric nature of amber, 75; general remarks on science of the, 35  
 Grew on vegetable anatomy, 137; on stomates, 138  
 Grove cited, 477  
 Guericke's air-pump, 119; Magdeburg hemispheres, 120; first electrical machine, 122; his experiments on electricity, 123  
 Gunpowder known to the Arabs, 42  
 Gutenberg, John, the printer, 55

- H**ALES, Dr., on gases, 225; on water in plants, 193  
 Hall, Asaph, on satellites of Mars, 457  
 Hall, Mr. C. More, on flint and crown glass, 166  
 Hall, Sir J., on melted rocks, 220  
 Hallé, Dr., pleads for Lavoisier's life, 238

## HUMAN

- Haller, early life of, 195; on contraction of the muscles, 196; on comparative anatomy, 196  
 Halley, his method of measuring transits, 155; observes transit of Mercury, 155; predicts the return of a comet, 159  
 Harding discovers Juno, 300  
 Harvey discovers circulation of the blood, 108; on development of the chick, 112  
 Hawksbee's electrical machine, 121  
 Heat, Bacon's examination of, 102; early theories about, 341; produced by friction, 342; latent, 240, 345; Joule's experiments on, mechanical equivalent of, 346; converted into motion, 350; production of electricity by, 365  
 Heat-rays discovered, 325  
 Heavy bodies, Galileo on motions of, 79  
 Helmholtz cited, 370; on conservation of energy, 352  
 Hercules, motions of our solar system towards, 285  
 Hermes and hermetic philosophers, 41  
 Hero's engine, 244  
 Herophilus on muscles, nerves, and the pulse, 26  
 Herschel, Sir W., 281; discovers Uranus and receives a pension, 283; on binary stars, 283; on nebulæ, 284; on motion of solar system through space, 285; discovers heat-rays, 325; on cause of sun-spots, 367  
 Herschel, Sir J., work in astronomy, 305; on spectrum analysis, 331  
 Herschel, Miss C., her brother's assistant, 286  
 Herschel, Mr. A., on spectrum of falling stars, 340  
 Hiero's crown, Archimedes on, 22  
 Higgins on chemical law of proportions, 388  
 Hipparchus, astronomy of, 29; discovers precession of equinoxes, 30  
 Hippocrates the father of medicine, 14  
 Hirn, M., his experiments on heat converted into motion, 350  
 Hodgson, Mr., on outbreak of a sun-spot, 369  
 Hoffmann, Dr., cited, 469  
 Homology, St. Hilaire on, 416  
 Hooke, one of the founders of the Royal Society, 123; on air-pump, 126; on combustion, 128; on geology, 215  
 Hooker, Sir W., on botany, 406  
 Horrocks observes transit of Venus, 154  
 Horse, ancestors of the, 446, 475  
 Huen island, Tycho's observatory on, 76  
 Huggins, Dr., on spectrum analysis of the stars, 338; of nebulæ, 339; measured movement of Sirius, 459  
 Human anatomy, Vesalius on, 65

## HUMBOLDT

- Humboldt, 408; on isothermal lines, 409; his 'Cosmos,' 408; on meteors, 307; pays expenses of Agassiz's work, 432
- Hunter, John, his birth and history, 197; on comparative anatomy, 198; his museum, 199
- Hutton on geology, 218; on granite veins, 221; on size and weight of Schehallion, 289
- Huyghens, history of, 174; invents cycloidal pendulum and describes Saturn's ring, 175; his undulatory theory of light explained, 175; on refraction of light, 177; on double refraction, 179
- Huxley on fossil bird-reptile, 446; on rapid multiplication of plants, 451; cited, 473
- Hydrogen discovered by Cavendish, 229; name given by Lavoisier, 238; amount of in water, 391; size of molecules of, 463; liquefaction and solidification of, 466
- I**CE, heat lost in melting, 241; melted by friction, 344; rocks scratched and blocks carried by, 433
- Iceland spar, double refraction in, 179
- Igneous rocks, Hutton on, 220
- Imperial Academy of Germany founded, 124
- Index of refraction, 107
- Indians, early science of, 4
- Indium discovered, 333
- Induction-coil, 365
- Inquisition banishes Vesalius, 66; burns G. Bruno, 81; forces Galileo to recant, 91
- Insects, Ray's work on, 141; microscopic anatomy of, 136; fertilisation of plants by, 451, 471
- Interference of light, 315; colours caused by, 316
- Inventions of nineteenth century, 468
- Invertebrate animals, Lamarck on, 413
- Ionian school of learning, 8
- Iron tools of lake-dwellings, 439
- Islands, formation of, 11
- Isothermal lines, Humboldt on, 409
- Italy, early scientific societies in, 124
- J**AMES, Sir H., on weight of the earth, 289
- Jansen makes a telescope, 85
- Janssen on photosphere of the sun, 337
- Jews, medical knowledge of the, 40
- Joule, Dr., experiments on the mechanical equivalent of heat, 346; cited, 462
- Juno discovered, 300
- Jupiter, atmosphere of, 338; his moons, 88; velocity of light measured by, 172; and Saturn, long inequality of, 279

## LEYDEN

- Jura mountains, erratics of the, 435
- Jussieu's natural system of plants, 209, 397
- K**ENT'S Hole, flint implements found in, 438
- Kepler, life of, 93; on structure of eye, 94; his telescope, 95; his first law, 95; second law, 97; third law, 98; his delight at Galileo's discoveries, 98; predicted transits of Mercury and Venus, 154; finished Rudolphine tables, 99
- Kerner on fertilisation of plants, 471
- Kircher invents magic lantern, 74
- Kirchhoff on dark lines in solar spectrum, 333; his spectroscope, 334
- Kite, Franklin's, 256
- Koran forbade dissection, 40
- L**ACTEALS discovered by Asellius, 112
- Lagrange, 276; on libration of the moon, 277; on stability of planetary orbits, 280
- Lake-dwellings of Switzerland, 438
- Lamarck, 411; on invertebrates, 413; on development of animals, 414; weak point in his theory, 415
- Lamont on variations of magnetic needle, 368
- Land, conversion of, into sea, 10
- Laplace, 277; on long inequality of Jupiter and Saturn, 280; on moon's acceleration, 280
- Lassell on Neptune's moon, 304
- Latent heat, Black on, 240; theory of, applied by Watt, 243; explained, 345
- Latitude, first parallel of, laid down, 27
- Laughing-gas, Davy's experiments with, 379
- Lavoisier the founder of modern chemistry, 234; his experiments, 236; his death, 238
- Law of compressibility of gases, 126; of definite proportions in chemistry, 387; of multiple volumes, 393; of gravitation, 148; of refraction discovered by Snellius, 104
- Laws of Kepler, 95, *et. seq.*
- Leaves of plants, Bonnet on use of, 200
- Leeuwenhœck on animalcules, 136
- Leibnitz on differential calculus, 145
- Leidy, Dr., on fossil animals, 475
- Lenses, Alhagen on use of, 48; Porta on, 74; Galileo on, 86; Kepler on, 94
- Lescarbault's supposed planet, 458
- Leslie, Sir J., on refraction of heat, 351
- Lever, Archimedes on the, 22
- Leverrier calculates the position of Neptune, 302; on November meteors, 308; his analysis of planetary orbits, 459
- Leyden, medical school of, 190

## LIBRATION

- Libration of the moon, 277  
 Liebig on organic chemistry, 393  
 Light, Euclid on rays of, 21; a vibration, 175; causing colour, 177; polarization of, 180, 309; compared to sound, 175; dispersion of, 161; blending of colours into white, 165; interference of, 315; bands of, in shadows, 316; undulations compared to waves of a pond, 315; reflection of from a soap-bubble, 317; complex vibrations of, 321; passage of through a crystal, 322; Roemer measures velocity of, 172; theories of, 173; undulatory theory explained, 175; Fizeau and Foucault on velocity of, 323  
 Lightning, electric nature of, proved by Franklin, 255; conductors, 257  
 Lillienthal, meeting of astronomers at, 299  
 Limestone, fixed air obtained from, 225; beds of Sicily, thickness of, 429  
 Lines in the spectrum, 330  
 Linnæan system, 207; collection brought to England, 211  
 Linnæus, early life of, 205; his 'Excursions,' 207; gives specific names to plants and animals, 207; death and character of, 211  
 Lippershey makes a telescope, 85  
 Liquefaction of permanent gases, 465  
 Lithuanian legend about falling stars, 306  
 Loadstone known to the Greeks, 53  
 Locke on heat, 341  
 Lockyer on spectrum analysis, 333, 337  
 Locomotive-engine, date of first, 244  
 Lœwy cited, 338  
 Looking-glass, cause of reflection of, 177  
 Loschmidt on size of molecules, 464  
 Lungs, circulation of blood through the, 111; studied by Malpighi, 135  
 Luxembourg Palace, polarized light reflected from windows of, 319  
 Lyell, Sir C., his history, 426; on present causes of geological change, 427; on Darwin's work, 448  
 Lymphatics discovered by Rüdbeck, 113
- M**CENERY on flint implements of Kent's Hole, 438.  
 Magdeburg hemispheres, 120  
 Magellan's ship sails round the world, 57  
 Magellanic clouds, 305  
 'Magia Naturalis' published, 72  
 Magic lantern invented, 74  
 Magnet, origin of name, 53; producing electric current, 364; and electric wires, mutual rotation of, 363  
 Magnetic field caused by electric currents, 358; needle, direction of, 357; variations of the, 57; Ampère on direction of, 359; sudden movement of, at Kew, 369

## MINERAL

- Magnetism, Gilbert on, 75; electro-, 360; terrestrial affected by sun-spots, 367  
 Magnifying glasses explained, 49  
 Malpighi applies the microscope to living structures, 134; discovers Malpighian layer, 136; on silkworm, 136; on structure of plants, 137  
 Malus on polarization of light, 308  
 Man, antiquity of, 437; selection of animals by, 450  
 Map made by Anaximander, 10; geological, made by W. Smith, 222  
 Marcus Græcus, gunpowder made by, 42  
 Mariner's compass, 54  
 Marquis of Worcester's engine, 244  
 Marriotte's law, 128  
 Mars, atmosphere of, 339; movements of explained by Kepler, 95; occultation of observed by Aristotle, 15; discovery of satellites of, 457  
 Marsh, Professor, on fossils of Rocky Mountains, 475  
 Maskelyne measures the density of the earth, 288  
 Matter, ultra-gaseous state of, 467  
 Maury on division of Biela's comet, 301  
 Maxwell, *see* Clerk-Maxwell  
 Mayer, Dr., on mechanical equivalent of heat, 347  
 Mayow discovers 'fire-air,' 130; his experiments on combustion and respiration, 129  
 'Mécanique Céleste' of Laplace, 281  
 Mechanical equivalent of heat, 347  
 Mechanics, definition of, 2  
 Medical school of Leyden, 191  
 Medicine, Hippocrates the father of, 14; Galen on, 34  
 Medusæ, nervous system of the, 474  
 Melloni on passage of heat rays, 351  
 Mercurial thermometer, how made, 118  
 Mercuric oxide, Priestley obtains oxygen from, 231  
 Mercury obtained from cinnabar by Geber, 44; sustained in a tube by weight of air, 116; combining with oxygen, 373  
 Mercury, transits of, observed, 154; planets within the orbit of, 458  
 Metals, Geber notices increased weight of heated, 44; electric discharge from two, 260; discovered by spectrum analysis, 333  
 Metamorphosis of plants, 398  
 Meteors and their paths, 306; their composition, 307; spectrum analysis of, 340  
 Microscope applied to living structures, 134  
 Middle Ages, science of the, 39-59  
 Milky Way studied by Democritus, 15; by Galileo, 88  
 Miller, Dr., on spectrum analysis of the stars, 338  
 Mineral waters analysed by Bergmann, 227

## MINERALOGY

- Mineralogy, Gesner on, 68; Werner's lectures on, 216  
 Mirbel on ovules, 403  
 Mohl, H. von, on protoplasm, 405  
 Moldenhauer cited, 402  
 Molecular theory of gases, 462  
 Molecules, size of, 464; vibration of, 464; ultra-gaseous state of, 467  
 Monochord invented by Pythagoras, 12  
 Monocotyledons, term explained, 142  
 Monro cited, 396  
 Mont Blanc, erratic blocks carried from, 435  
 Moon, Anaxagoras on the, 13; phases of explained by Anaximander, 10; Thales on reflection of the, 9; secondary light of the, 87; movement of used by Newton to test his law of gravitation, 146; Lagrange on libration of, 277; why she turns the same face to us, 278  
 Moons, Jupiter's, 88  
 Moraines of glaciers, 433  
 Moro, Lazzaro, on formation of strata, 215  
 Morse, his electric telegraph, 371  
 Mountain-chains, Eratosthenes studies, 29  
 Mouse consuming air in a bell-jar, 132  
 Mud carried down by the Ganges, 429  
 Müller, Dr. H., on plants and insects, 470  
 Murchison cited, 428, 431  
 Muscles, Haller on contraction of the, 197  
 Musical notes, Pythagoras on, 12; Galileo on, 80; Sauveur on number of vibrations in, 265; sand-figures formed by, 273
- N**APOLEON I. takes St. Hilaire to Egypt, 413  
 Natural history of seventeenth century, 138  
 Natural philosophy, Leonardo da Vinci on, 58  
 Natural selection, theory of, 448; objection to the theory of, 449; difficulties of natural history explained by, 453; does not exclude Divine Power, 454  
 Natural system of plants, 209, 397  
 Nebulæ, Herschel on the nature of, 284; spectrum analysis of, 339  
 Nebular hypothesis, 281  
 Negative and positive electricity, 255, 261  
 Negro, colouring matter in skin of, 135  
 Neptune, position of found by Adams and Leverrier, 302; seen by Galle, 304; his moons, 304  
 Neptunists and Vulcanists, 217  
 Nerves, Galen on two sets of, 34  
 Nestorians, science of the, 40  
 Neufchatel, erratic block near, 435  
 Newcomen's engine, 244  
 Newt, regrowth of eye of, 201

## OXYGEN

- Newton, birth and early life of, 144; his law of gravitation, 145; his method of fluxions, 145; on variation of attraction, 150; on cause of tides, 152; on specific gravity of planets, 152; on shape of the earth, 152; on precession of equinoxes, 152; on motion of comets, 152; on sound, 166; on chemical attraction, 228; on attraction of plumbline to a mountain, 287; on dispersion of light, 161; explains the spectrum, 162; his rotating disc, 165; his work on chemistry destroyed, 170; his work on optics, 166; his theory of light, 173, 303; on nature of sound, 166  
 Nicholson on decomposition of water by electricity, 380  
 Nile, mud carried down by, 11  
 Nineteenth century, tendency of science of, 477  
 Nitrogen, compounds of oxygen with, 373; Rutherford on, 234; liquefaction of, 467  
 Nitrous oxide, Davy's experiments on, 379  
 Nobili on animal electricity, 259  
 Noble on stretched strings, 263  
 Nodes in musical strings, 267  
 'Novum Organum,' 101  
 Numerals, Indian, introduced into Europe, 46  
 Nutation of earth's axis, 275
- O**BLIQUITY of ecliptic, Anaxagoras on, 21  
 Observatory, Tycho's, 376  
 Oersted on electro-magnetism, 356  
 Olbers, Dr., discovers Pallas and Vesta, 300  
 Optics, Alhazen on, 46; Porta on, 72; Kepler on, 94; Newton's work on, 166; 'Opus Majus' of Roger Bacon, 51  
 Orbits of the planets, elliptical, 96; governed by gravitation, 149  
 Organic compounds, chemistry of, 190; Liebig on, 393; recent advances in, 469  
 Organs of digestion arranged by Hunter, 199; modification of, 414; St. Hilaire on modification of, 443  
 Origin of species, 448  
 'Ossemens Fossiles' published, 421  
 Ovid's 'Metamorphoses,' 11  
 Oviparous and viviparous animals, 140  
 Owen on classification, 473  
 Oxford, early meetings of Royal Society at, 123  
 Oxygen called 'fire-air' by Mayow, 130; discovered by Priestley and Scheele, 230; amount of in water, 391; compounds of with nitrogen, 389; liquefaction of, 466

## PALISSY

- PALISSY** on fossil shells, 214  
 Pallas discovered, 300  
 Palæontology, growth of, 473  
 Papin's engine, 245  
 Parabolas described by comets, 150  
 Paracelsus, chemistry of, 70  
 Paris, Cuvier on fossil animals of, 420  
 Parker, W. Kitchen, on structural links in the vertebrate kingdom, 425, 473  
 Pascal on pressure of the atmosphere, 117  
 Pecquet on thoracic duct, 112  
 Peltier cited, 366  
 Pericles pleads for Anaxagoras, 14  
 Perrier, M., carries a barometer up the Puy de Dome, 117  
 Pendulum, Galileo on the, 77  
 Phases of moon, 10; of Venus, 89  
 Philosopher, name first given to Pythagoras, 12  
 Philosophical transactions begun, 124  
 Phlogiston, theory of, 132; destroyed by Lavoisier, 237  
 Photography explained, 327; used in astronomy, 457  
 Photosphere of the sun, 337  
 Physical forces, correlation of the, 476; geography, Humboldt on, 408  
 Physics, definition of, 2; of sixteenth century 80; of seventeenth century, 184; of eighteenth century, 292  
 Physiology, beginning of the study of, 108  
 Piazzi discovers Ceres, 299  
 Picart, size of the earth measured by, 147  
 Pickering on size of satellites of Mars, 457  
 Pictet liquefies permanent gases, 466  
 Pierre-à-Bot, an erratic block, 435  
 Pigeons, common descent of different varieties of, 450  
 Pigot on stretched strings, 263  
 Pisa, Galileo and the men of, 78  
 Pith of elder, cells in, 137; ball attracted and repelled by rubbed sealing-wax, 122  
 Planets, Anaxagoras on, 14; Eudoxus on, 15; Kepler's laws concerning the, 95-99; held in their orbits by gravitation, 149; minor, or asteroids, 299; stability of their orbits proved by Lagrange, 280; their weight and size calculated by Leverrier, 459; intermercurial, 458  
 Plants, Aristotle on low organisation of, 16; Theophrastus on, 17; microscopic structure of, 137; ashes of, examined by Boerhaave, 192; Hales on breathing of, 193; Bonnet on leaves of, 200; Gesner on, 68; Cæsalpinus on, 69; Ray on, 141; Linnæus, artificial system of, 209; Jussieu, natural system of, 209, 397; specific names given to, 208; Humboldt on distribution of, 409; metamorphosis of, 398; Priestley on breathing of, 231; fertilisation by insects, 400; colouring matter in, 469; carnivorous, 471  
 Plates, vibrations of musical, 273

## RED

- Playfair's illustrations of Hutton, 218  
 Pliny the naturalist, 33  
 Polarization of light, 180; by reflection, 318; circular, 323  
 Porta, his meetings in Naples, 72; his camera obscura, 73; on the eye, 74; his engine, 244  
 Positive and negative electricity, 255  
 Potassium discovered by Davy, 381  
 Potter, Humphrey, ties the engine-cocks, 246  
 Precession of equinoxes discovered by Hipparchus, 30; Newton on, 151  
 Pressure and volume, relations of, 128  
 Prestwich on flint implements, 438  
 Priestley, his discoveries, 230-233  
 Prism, light dispersed in a, 162  
 Prismatic colours, Newton on, 164  
 'Principia,' some problems discussed in the, 151  
 'Principles of Geology' published, 429  
 Printing, invention of, 55  
 Proctor on shooting stars, 309  
 Proportions, law of definite, 387  
 Protoplasm explained, 405  
 Proust on chemical law of proportions, 388  
 Ptolemaic system, 32  
 Ptolemies patrons of learning, 18  
 Ptolemy, astronomy of, 32; geography of, 33; 'cloudy stars' seen by, 284  
 Pulmonary circulation of the blood, 111  
 Pulse studied by Herophilus, 27  
 Pump, height that water will rise in, 114  
 Pythagoras, science of, 11, 213; his monochord, 12  
 Pythagorean system, 21

**QUADRANT** made by Copernicus, 64  
 Quadrupeds, Ray's work on, 140  
 Quicklime, nature of, 225

- RABBITS** descended from one wild stock, 415  
 Radiometer, 467  
 Rain, denuding effects of, 427  
 Rainbow, De Dominis on, 161  
 Ramsay, Professor, cited, 217  
 Ray and Willughby, history of, 139; on quadrupeds, 140; on birds, fishes, and insects, 141; on plants, 141; on geology, 215  
 Rays of light, index of refraction of, 107; Euclid on, 21; Alhazen on refraction of, 47; Kepler on, 94; Young and Fresnel on, 329; Newton on refraction of coloured, 162; non-interference of ordinary and extraordinary, 321; paths of through a crystal, 322; discovery of chemical and heat, 325-328  
 Réaumur's scale, freezing point of, 118  
 Red fire made by burning strontium, 332

## RED

- Red prominences of the sun, 337.  
 Reflection of light, 176; polarization of light by, 319  
 Refraction explained by Alhazen, 47; explained by Huyghens, 177; figures illustrating, 178; double, 179; Snellius discovers law of, 104; method of measuring, 105; of coloured rays, 161  
*Règne Animal*, Cuvier's, 418  
 Reptiles, gigantic fossil, 445, 475  
 Repulsion by electricity, 122  
 Respighi on height of red prominences, 337  
 Respiration, Boyle on air used in, 128; Mayow on effects of fire-air in, 129  
 Richter on chemical law of proportions, 388; and Reich discover indium, 333  
 Rieban, Faraday's master, 361  
 Ritter discovers chemical rays, 326  
 Rivinus on plants, 208  
 Robison on Watts, 244  
 Rocks, diagrams of, bent and broken, 216; new ones formed out of old, 219  
 Rocky Mountains, fossils of the, 475  
 Roe of codfish, animalcules in, 136  
 Roemer measures velocity of light, 172  
 Roger Bacon makes gunpowder, 52; his experiments on air, 52  
 Romanes on nervous system of *Medusæ*, 474  
 Ronald's, Mr., attempt at electric telegraph, 370  
 Rose, modification of parts in the, 399; number of species of, 442  
 Rothmann, Dr., befriends Linnæus, 205, 206  
 Royal Institution, Young professor at, 312 Davy at, 379; Faraday at, 362  
 Royal Society founded, 123; early members of, 125; Newton learns the real size of the earth at the, 147  
 Rubidium discovered, 333  
 Rüdbeck discovers lymphatics, 113  
 Rudimentary organs, 443  
 Rudolph II. protects Tycho and Kepler, 76, 93  
 Rudolphine tables, 93; used to predict transits, 154  
 Rumford, Count, 342; produces heat by friction, 343; appoints Davy to Royal Institution, 379  
 Rutherford, Dr., on nitrogen, 234
- S**ABINE, Sir E., on connection between sun-spots and magnetic currents, 369; on weight of our earth, 289  
 Sachs, Professor, cited, 471  
 St. Hilaire, G., 412; on Egyptian animals, 413; on homologous parts of animals, 417  
 Salamanders, re-growth of limbs of, 201  
 Sal-ammoniac known to the Arabs, 45  
 Salerno, medical school of, 40

## SMITH

- Salt, colour of burning, 332  
 Salts of plants extracted, 193  
 Sand-figures, musical, 273  
 Sanderson, Dr. B., on carnivorous plants, 471  
 Sap, Ray and Willughby on, 140  
 Satellites of Jupiter, 88; eclipses of, 172  
 Satellites of Mars, 458  
 Saturn, atmosphere of, 339; weight of, 151; his ring seen by Galileo, 90; and Jupiter, long inequality of, 279  
 Saussure, De, on glaciers, 434  
 Sauveur on musical sound, 263  
 Savery's engine, 245  
 Scheele, discoveries of, 230; on chemical rays of light, 326  
 Schehallion experiment, diagram of, 288  
 Schiaparelli on August meteors, 308  
 Schimper cited, 473  
 Schœffer, Peter, the printer, 55  
 Schwabe on periodicity of sun-spots, 367  
 Science, definition of, 1; of the Greeks, 7; decay of Greek, 35; of the Middle Ages, 39, 59; of the Arabs, 39; rise of modern, 61 *et seq.*; of sixteenth century, 80; seventeenth century, 182; eighteenth century, 289; academies of, 122  
 Scilla on Calabrian fossils, 214  
 Scotland, glaciation of, 436  
 Screw of Archimedes, 25  
 Sea, land eaten away by the, 429  
 Seasons caused by obliquity of ecliptic, 20  
 Section of the skin, 136  
 Sedgwick cited, 431  
 Seebeck, Professor, discovers thermo-electricity, 365  
 Seeds and eggs, growth of, compared, 138; classification of plants by, 69; Robert Brown on structure of, 403  
 Segments in musical strings, 267  
 Séguin, M., on mechanical equivalent of heat, 347  
 Selection of animals by man, 450; natural, 450  
 Serapis, rise and sinking of temple of, 430  
 Servetus on circulation of blood, 108  
 Seventeenth century, characteristic work of, 476; summary of science of the, 182  
 Shooting-stars, a legend concerning, 306  
 Sicily, thickness of limestone rocks in, 429  
 Silkworm, Malpighi on structure of, 136  
 Simpson, Dr., on chloroform, 395  
 Sines of incident and refracted rays, 106  
 Sirius, movements of, 459  
 Sixteenth century, advance of science in the, 80, 476  
 Skaptar Jokul, torrent of lava from, 430  
 Skin, section of, 136  
 Slough, Herschel's observatory at, 283, 305  
 Smith, Sir E., brings Linnæan collection to England, 211

## SMITH

- Smith, William, surveys England, 221  
 Snails, regrowth of parts in, 201  
 Snellius discovers law of refraction, 104  
 Soap-bubble, Newton on the, 166; cause of colours on the, 317  
 Soda, composition of, 391  
 Sodium discovered by Davy, 381; power of to decompose water, 391; spectrum of, 332; Kirchhoff's experiments with vapour of, 335  
 Soho, manufactory of engines at, 250  
 Soil, substances taken from, by plants, 193  
 Solar spectrum, dark lines in, 330; system, motion of through space, 285  
 Solstices observed by Thales, 9
- Sound, Newton on, 166; light compared to, 175; Pythagoras on, 12; Galileo on musical, 80; Newton on transmission of, 166; Sauveur and Chladni on musical, 263-274  
 Spallanzani on regrowth of severed limbs, 201  
 Specific gravity first measured by Archimedes, 23  
 Specific names given by Linnæus, 207  
 Spectra, table of, 330  
 Spectroscope, movement of stars studied by, 459  
 Spectrum studied by Newton, 162; dark lines on the, 330; their cause explained, 333; of different substances, 331; of gases, 332; of solids, 332  
 Spectrum analysis, history of, 329-340; metals discovered by, 333; of sunlight, 336; of stars, 338; of nebulae, 339; of meteors, 340; use of, in chemistry, 386  
 Spencer, Herbert, on evolution, 478  
 Spirit, Arabian name for gas, 42  
 Spirits of wine made by Geber, 44  
 Spots on the sun, periodicity of, 367  
 Sprengel on insects and plants, 400  
 Stahl on phlogiston, 133  
 Star, morning and evening, 11; -clusters and nebulae, Sir W. Herschel on, 281  
 Stars, binary, 283; spectrum analysis of the, 338; movement of, 459  
 Statics, Stevinus on, 80  
 Steam condensation of, 248; latent heat of, 242  
 Steam-engine, history of the, 244; Newcomen's 245; Watt's, 249  
 Steinhill on electric telegraph, 371; on earth acting as return wire, 373  
 Steno on fossils in the earth's crust, 214  
 Stereoscope, Sir J. Herschel on the, 336  
 Stevinus on statics, 80  
 Stewart, Balfour, cited, 333, 338  
 Stokes, Professor, on dark lines in solar spectrum, 333  
 Stomachs of animals, peculiarities of, 199

## TORRICELLI

- Stone tools of lake-dwellings, 439  
 Strabo on earthquakes and volcanoes, 33  
 Strata of England mapped by W. Smith, 221  
 Striæ caused by glaciers, 434  
 Strings, laws of vibration in musical, 266  
 Struve on Neptune's moons, 304;  
 Sublimation described by Geber, 44  
 Sulphuric acid made by Geber, 45  
 Summary of science of sixteenth century, 80; of seventeenth century, 182; of eighteenth century, 280  
 Sun, experiment to explain the movement of the earth round the, 19; seen after setting by means of refraction, 48; rotation on its axis proved by Galileo, 90; his distance 108 times his diameter, 155; method of measuring the diameter, 155; distance from the earth, 158; holds the planets round it by gravitation, 148; meteors falling into, 310; atmosphere of vapours surrounding the, 336  
 Sun-dial invented by Anaximander, 10  
 Sun-spots seen by Galileo and Harriot, 90; Sir W. Herschel on cause of, 367; Schwabe on periodicity of, 367; their connection with magnetic currents, 368  
 Switzerland, glaciers of, 434; lake-dwellings of, 439  
 Syene, earth's circumference measured from, 29  
 Syntaxis of Ptolemy, 32  
 Synthesis, term explained, 387  
 'System of the World,' by Galileo, 91  
 'Systema Naturæ,' published, 210
- T**ALBOT, Fox, on sun-pictures, 327; on spectra of flames, 331  
 Telegraph (*see* electric telegraph)  
 Telephone, description of, 375  
 Telescope, Roger Bacon's idea of, 52; invention of the, 87; Galileo's, 89; Kepler's, 97; achromatic, 169; largest refracting and reflecting, 456  
 Tessier, Abbé, meets Cuvier, 390  
 Tests, Bergmann on chemical, 229  
 Thales, science of, 8  
 Thallium discovered, 333  
 Theophrastus the first botanist, 17  
 'Theory of the Earth' published, 218  
 Thermo-electricity, discovery of, 365  
 Thermometer, invention of the, 118  
 Thompson, Benjamin (*see* Rumford)  
 Thomson, Dr., on Dalton's theory, 392  
 Thomson, Sir W., on dissipation of energy 353; on size and vibration of molecules, 463; cited, 333, 464  
 Thoracic duct, Pecquet on the use of, 112  
 Tides, Newton on cause of, 152  
 Torricelli on weight of atmosphere, 114; invents barometer, 116



## TORRICELLIAN

- Toricellian vacuum, 118  
 Tournefort's classification of plants, 142  
 Tower, Hunter dissects the wild beasts of the, 198  
 Transits of Mercury and Venus, 153; Halley's method of measuring, 155; Delisle's method of measuring, 277; diagrams of, 156; expeditions, 159  
 Trianon, Jardin de, 207  
 Tycho Brahe, his life and astronomical work, 75; Galileo and Kepler compared, 99  
 Tychonic system, 75  
 Tylor, E. B., illustrations of refraction of light, 178  
 Tyndall, Dr., on heat, 352
- UNDULATORY** theory of light, 175; explains interference, 311  
 Upsala, Linnæus's botanical garden at, 207  
 Uranienburg, Tycho's observatory at, 76  
 Uranus, discovery of, 281; its irregular movements lead to discovery of Neptune, 304
- VACUUM**, Torricellian, 118  
 Valleys, excavation of, 11  
 Valves in veins discovered by Fabricius, 109; use of, 109  
 Van Helmont, chemistry of, 70  
 Varieties, useful ones alone survive, 449  
 Vasco de Gama sees southern stars, 57  
 Vegetable anatomy, 137  
 Veins, Galen on, 34; action of, discovered by Harvey, 109; valves in, discovered by Fabricius, 109  
 Velocity of light measured, 172  
 Venus, phases of, agree with Copernican theory, 89  
 Venus, transits of, 153; used to measure sun's distance, 156; Halley's method of measuring, 155; diagrams illustrating, 157; Delisle's method of measuring, 276  
 Vertebrata, term explained, 418  
 Vesalius, his work in anatomy, 65; banishment and death of, 66  
 Vessels and fibres of plants, 137  
 Vesta discovered, 300  
 Vibrations, light a series of, 176; of light complex, 321; calculation of musical, 263  
 Vinci, Leonardo da, inventions of, 58  
 Vital fluids, belief of alchemists in, 192  
 Vitellio on refraction, 104  
 Viviparous and oviparous animals, 140  
 Volcanoes, Pythagoras on, 12; mass of lava thrown out from, 430  
 Voltaic electricity, 259; pile, 261  
 Volta on electricity, 257; his crown of cups, 260; his controversy with Galvani, 259

## ZOOLOGY

- Volume and pressure, relations of, 120  
 Von Baer on embryology, 422  
 Voyages round the world, 56  
 Vulcan, god of volcanoes, 7  
 Vulcanists and Neptunists, 217
- WALES**, moraines and erratic blocks of, 436  
 Wallace, Mr. A. R., figures drawn by, 95; on natural selection, 447; on prolificness of birds, 450  
 Wallis, Dr., his description of the Royal Society, 123  
 Washington, telescope at, 456  
 Water, composition of, 380, 391; rising in a vacuum, 114; latent heat of, 240; boiled by friction, 343; rise of temperature in, by friction, calculated, 348; decomposed by sodium, 391  
 Watson, Professor, on new planets, 458  
 Watt, his early life, 242; not the first to make a steam-engine, 244; his separate condenser, 247; his double-acting engine, 250; his partnership with Boulton, 250; Wave-theory of light, 175; explains interference, 311  
 Waves of light in a crystal, 322  
 Weber cited, 370  
 Wedgwood, Dr. T., on sun-pictures, 326  
 Weight of bodies explained by gravitation, 151; of chemical elements, 389  
 Wenzel on law of definite proportions, 388  
 Werner on rocks and fossils, 216  
 Wheatstone on musical vibrations, 274; patents electric telegraph, 370  
 William of Orange founds Leyden University, 191  
 Williamson, Prof., cited, 468  
 Willughby and Ray, 139; on classification of animals, 138  
 Wöhler on chemistry of organic compounds 393; cited, 469  
 Wolff on metamorphosis of plants, 400  
 Wollaston, Dr., observes dark lines in the spectrum, 328  
 Woodward, his geological collection, 215  
 World, first voyages round the, 56  
 Worm, regrowth of divided parts of the, 201  
 Würtz, Professor, cited, 469
- YEAR**, length of, calculated, 45  
 Young, Dr., his life, 312; on interference of light, 321; and Frénel on polarization of light, 321
- ZODIAC**, or circle of animals, 19  
 Zoology, Aristotle on, 16; Gesner on, 67; Ray and Willughby on, 138; Linnæus on, 207; Cuvier, St. Hilaire, and Goethe on, 411 *et seq.*; Darwin on, 447  
 recent advances in, 473

*Printed by* EDWARD STANFORD, 55 *Charing Cross, London, S.W.*

# RECENT PUBLICATIONS.

By the same Authoress.

## WINNERS IN LIFE'S RACE; OR, THE GREAT BACKBONED FAMILY.

Crown 8vo, with numerous Illustrations, cloth, gilt edges, 8s. 6d.

### EXTRACT FROM PREFACE.

"Although the present volume, as giving an account of the *vertebrate* animals, is a natural sequel to, and completion of, my former book, *Life and her Children*, which treated of *invertebrates*, yet it is a more independent work, both in plan and execution, than I had at first contemplated. \* \* \* \* \*

I have endeavoured to describe graphically the early history of the backboned animals, so far as it is yet known to us, keeping strictly to such broad facts as ought in these days to be familiar to every child and ordinary well-educated person, if they are to have any true conception of Natural History. At the same time I have dwelt as fully as space would allow, upon the lives of such modern animals as best illustrate the present divisions of the vertebrates upon the earth; my object being rather to follow the tide of life, and sketch in broad outline how structure and habit have gone hand-in-hand in filling every available space with living beings, than to multiply descriptions of the various species."\*

### CONTENTS.

Chapter.	Chapter.
I. The Threshold of Backboned Life.	ing, from Mound-Laying to Nest-Building, from Cry to Song.
II. How the quaint old Fishes of Ancient Times have lived on into our day.	VIII. The Mammalia or Milk-Givers, the Simplest Sucking Mother, the Active Pouch-Bearers, and the Imperfect Toothed Animals.
III. The Bony Fish, and how they have spread over Sea, and Lake, and River.	IX. From the Lower and Small Milk-Givers which find safety in concealment, to the Intelligent Apes and Monkeys.
IV. How the Backboned Animals pass from Water Breathing to Air Breathing, and find their way out upon the Land.	X. The Large Milk-Givers which have conquered the World by Strength and Intelligence.
V. The Cold-Blooded Air-Breathers of the Globe in Times both Past and Present.	XI. How the Backboned Animals have returned to the Water, and large Milk-Givers imitate the Fish.
VI. The Feathered Conquerors of the Air.—Part I. Their Wanderings over Sea and Marsh, Desert and Plain.	XII. A Bird's-eye View of the Rise and Progress of Backboned Life.
VII. The Feathered Conquerors of the Air.—Part II. From Running to Fly-	

\* (Almost every animal mentioned in the book is to be found alive in the London Zoological Gardens, or stuffed in the British Museum.)

"One secret of Miss Buckley's success as a popular expounder of the abstruse results of the highest scientific research is her own mastery of the processes and results. She is content with no second-hand knowledge; she has in all cases gone to the fountain head. . . . It would be difficult to make the subject more attractive, or the pictures of backboned life through all its phases more realistic. As a popular exposition of the progress of life on the lines of evolution we know of nothing better. The numerous illustrations are beautifully and faithfully executed."—*Times*.

"An account of vertebrate animals, written with such natural spirit and vivacity, that it might convert even a literary person to natural science."—*Saturday Review*.

"We can conceive no better gift-book than this volume. Miss Buckley has spared no pains to incorporate in her book the latest results of scientific research. The illustrations in the book deserve the highest praise: they are numerous, accurate, and striking."—*Spectator*.

## RECENT PUBLICATIONS.

---

By the same Authoress.

### THE FAIRY-LAND OF SCIENCE.

Fourteenth Thousand, Crown 8vo, with 74 Illustrations, cloth gilt, gilt edges, 6s.

“Her methods of presenting certain facts and phenomena difficult to grasp are most original and striking, and admirably calculated to enable the reader to realise the truth. As to the interest of her story, we have tested it in a youthful subject, and she mentioned it in the same breath with ‘Grimm’s Fairy Tales.’ . . . The book abounds with beautifully engraved and thoroughly appropriate illustrations, and altogether is one of the most successful attempts we know of to combine the *dulce* with the *utile*. We are sure any of the older children would welcome it as a Christmas present; but it deserves to take a permanent place in the literature of youth.”—*Times*.

---

By the same Authoress.

### LIFE AND HER CHILDREN.

GLIMPSES OF ANIMAL LIFE FROM THE AMŒBA  
TO THE INSECTS.

Seventh Thousand, Crown 8vo, with upwards of 100 Illustrations, cloth gilt, gilt edges, 6s.

“None will read its introductory chapter without advantage, and few will read the volume through without enjoyment. . . . What constitutes the book’s chief charm is the marvellously simple, yet quite scientific, style which runs through it; the food for thought and future study which it affords; and the truly philosophic glow which lights up its every page. . . . The work forms a charming introduction to the study of zoology—the science of living things—which, we trust, will find its way into many hands.”—*Nature*.

“This book is a substantial addition to the library of every teacher of natural science. It appears in the guise of a gift-book at a festive season of the year, but its real value will scarcely be understood until the summer studies of the young biologist begin. It is not merely a duty but a pleasure to recommend its attractive and carefully written pages.”—*Academy*.

---

By the same Authoress.

### BOTANICAL TABLES FOR THE USE OF JUNIOR STUDENTS.

TABLE OF COMMON TERMS USED IN DESCRIBING PLANTS,  
*Comprising those usually required in the Cambridge  
Local Examinations for Juniors.*

Also a Table of the Chief Natural Orders of British Plants, arranged according to BENTHAM and OLIVER.

Third Edition. Folded in cloth cover, 1s. 6d.

“The arrangement is good, and to every one looking forward to taking up botany as an examination subject, these careful tables are almost indispensable.”—*School Guardian*.

---

LONDON: EDWARD STANFORD, 55 Charing Cross, S.W.













