







0 0301 0053742 9



DESCRIPTION OF THE SHIP AND  
APPLIANCES USED FOR SCIENTIFIC EXPLORATION



Siboga-Expeditie  
II

---

DESCRIPTION OF THE SHIP AND  
APPLIANCES USED FOR SCIENTIFIC EXPLORATION

BY

G. F. TYDEMAN

---

With 3 plates and illustrations

---

LATE E. J. BRILL  
PUBLISHERS AND PRINTERS  
LEYDEN





# DESCRIPTION OF THE SHIP AND APPLIANCES USED FOR SCIENTIFIC EXPLORATION

BY

G. F. TYDEMAN.

---

With 3 plates and illustrations.

H. M. twin-screw Gun-boat "Siboga", of the Dutch East India Military Marine Service was built in 1897 by the Netherland Ship-building Company at Amsterdam.

The vessel is of steel, has twin screws, bilge-keels, steam-capstan, steam-steering-gear, electric light and search-light, two triple-expansion engines, two cylindrical boilers fitted with forced draught and one auxiliary boiler.

The principal dimensions are:

Length . . . . .	50.60 metres
Extreme width . . . . .	9.40 "
Average draught when full loaded	3.308 "
Displacement at above draught . .	810 tons.

The armament consists of:

- 2 Krupp guns of 10.5 centimetres (1 fore and 1 aft).
- 4 quick-firing guns of 3.7 centimetres.
- 2 revolving " " 3.7 "

The engines were designed for 1100 I. H. P. collectively, but developed on the trial trip 1395 I. H. P., at 219.6 revolutions; the speed attained was 13.8 knots with a coal-consumption of 1.108 kilograms per I. H. P. per hour. With 201 I. H. P. and 120 revolutions a speed of 8.34 knots was attained.

One of the longboats is a steamlaunch 7.62 metres (25 ft.) long.

After the launch in 1898, and while the building was being completed the ship was ordered to join the deep-sea expedition in the East-Indian Archipelago conducted by Prof. Dr. MAX WEBER. It was therefore equipped with appliances and machinery necessary for this purpose. This work was executed at the Government dockyard in Amsterdam under the supervision of Professor WEBER and with the co-operation of the commander and the Naval Architect J. VAN DER STRUIJF, who had superintended the building of the ship from the beginning.

The principal appliances used in the deep-sea exploration are illustrated on Plate I—III and in the following figures.

For the manipulation of the heavier nets, (trawls, dredges and vertical nets) a steel wire rope was used 10000 metres long, wound on a reel, situated between decks forward. This cable or dredge-rope consisted of two lengths coupled together by a plate joint.

The inner-length of 4000 metres, was 12 millimetres in diameter, the outer-length of 6000 metres, had a diameter of 10 millimetres. On arrival in the East-Indies another 6000 metres of rope of 10 millimetres were taken on board as reserve, while for the fishing with closing nets etc. 2000 metres of rope of 8 millimetres and 2000 metres of 6 millimetres were added.

These wire ropes were supplied by TH. and WM. SMITH of Newcastle upon Tyne and Hamburg. Their weights and breaking strains were respectively:

Diameter of rope.	Weight per metre.	Breaking strain.
12 millimetres.	0.52 kilograms.	7000 kilograms.
10        "	0.38        "	4800        "
8         "	0.28        "	3000        "
6         "	0.14        "	1600        "

The ropes were of excellent quality. No breakages occurred either in trawling or in dredging, except such as resulted from twisting when paying out, in consequence of which pieces had occasionally to be cut off, the total loss during the voyage amounting to 800 metres. Besides this, 200 metres were lost when weighing anchor at the Lucipara-islands, and the 10 millimetres rope had to be cut in one place on account of the snapping of a strand; the two ends were spliced together again.

The lead of the dredge-rope *C* (Plate I—III) as decided upon after some alterations had been made, was for the lowering of the nets as follows:

From reel *I* situated between decks forward, it passed through the blocks *d* and *c'* with a few turns round starboard friction stopper *M* to the deck; then round another friction-stopper *L*, on to the odometer *b*, from there over the steel-blocks *a, a, a*, from the top of the boom *B* overboard.

For winding in the dredge-rope the steam-capstan *K* was used, the chain groove of which was temporarily fitted with a circular rim of strong wooden blocks protected with gun-metal clamps.

The diameter of this rim was 0.93 metres, or about twice the size of the top of the capstan. The object of this contrivance being to obtain the advantage of the greater circumference, and to secure a lower position for the dredge-rope on the capstan.

Later on another similar arrangement of blocks was made more suitable for very great depths, having a reduced diameter of 0.50 metres.

To enable the rope to be taken 5 turns round the capstan it had to be temporary gripped by the steel-stopper  $A$  which was fixed to the boom; when winding in, the rope was led by a snatch block  $c$ .

The dredge-rope was wound on the reel by means of an electromotor  $U$ , coupled by a leather belt.

The wooden boom  $D$ , 20 centimetres in diameter, was attached to the fore mast and provided with stays. It was slung by a steel wire rope  $H$ , 27 millimetres in diameter, led through a block about on a level with the fore-yard. The lower end of this rope was spliced on to the upper part of the accumulator  $A$ , the lower end of which was bolted to the deck. By means of this contrivance sudden shocks and strains of the dredge-rope and the boom were avoided.

The accumulator (Fig. 1) consisted of 6 pairs of steel spiral springs, having a combined length of 3.00 metres. Each pair consisted of a heavy external spring with a lighter spring of smaller dimensions inside. The whole was constructed for a maximum load of 10000 kilograms. At this load the compression was calculated to be about one metre.

The amount of compression on the accumulator enabled the person on the bridge who conducted the dredging operation, to judge roughly the momentary tension of the dredge-rope. A more accurate test however was furnished by the hydraulic dynamometer  $D$  of a well-known type, constructed for loads up to 10000 kilograms, and attached to the star-board anchor-chain bitt  $F$  by means of the steelwire-strop  $E$  of 27 millimetres diameter.

Since the two leads of the dredge-rope during the winding-in formed an angle of about  $60^\circ$ , round the sheave of the block, attached to the dynamometer, the actual pull of the dredge-rope was in round figures 0.6 times that, indicated on the dynamometer.

The block was slung from the fore castle-deck to prevent the dynamometer falling on the deck. The foremast was supported by two stays  $I$ .

The sheaveblocks (Fig. 2) over which the dredge-rope passed were of iron with brassbushed sheave and steel pin, the groove

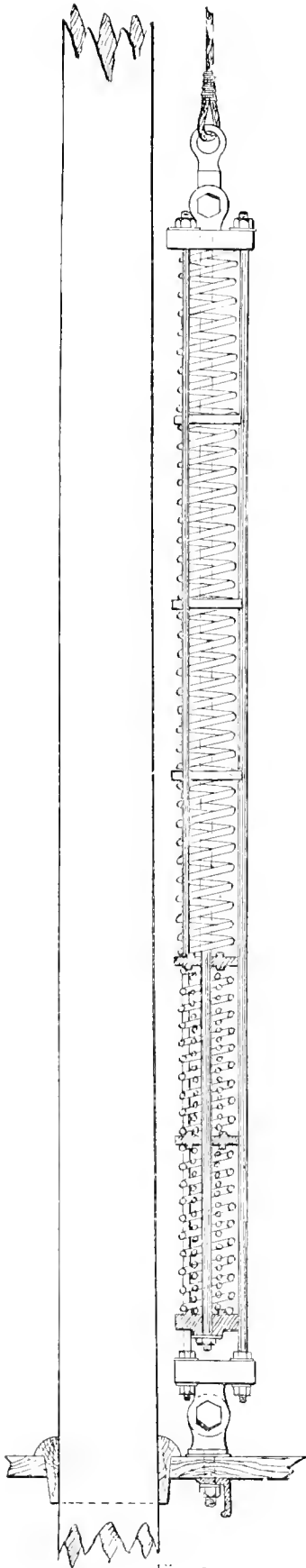

Fig. 1.  
Accumulator. Scale:  $1/20$ .

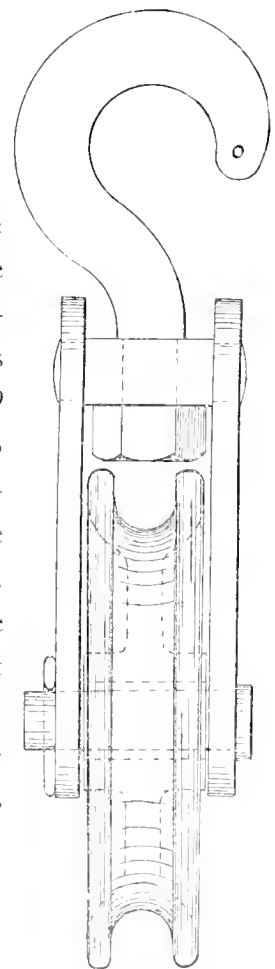

Fig. 2.  
Steel block. Scale:  $1/10$ .

in the sheaves were 10 mm. wide to allow the couplings and splices to pass freely. The blocks at the lower end of the boom, as well as that of the dynamometer, and the snatch block *d* (Plate I) were provided with wrought iron-sling by which they were held up.

The construction of the odometer *b* (Plates I and II) was similar to that of the blocks but with fixed spindle. Originally it had a circumference of about 0.83 metre, but gradually this wore down to 0.80 metre. It was fitted in a cast iron bracket on a portable wooden block. In one of the ends of the spindle there was a square hole to take the driving spindle of a

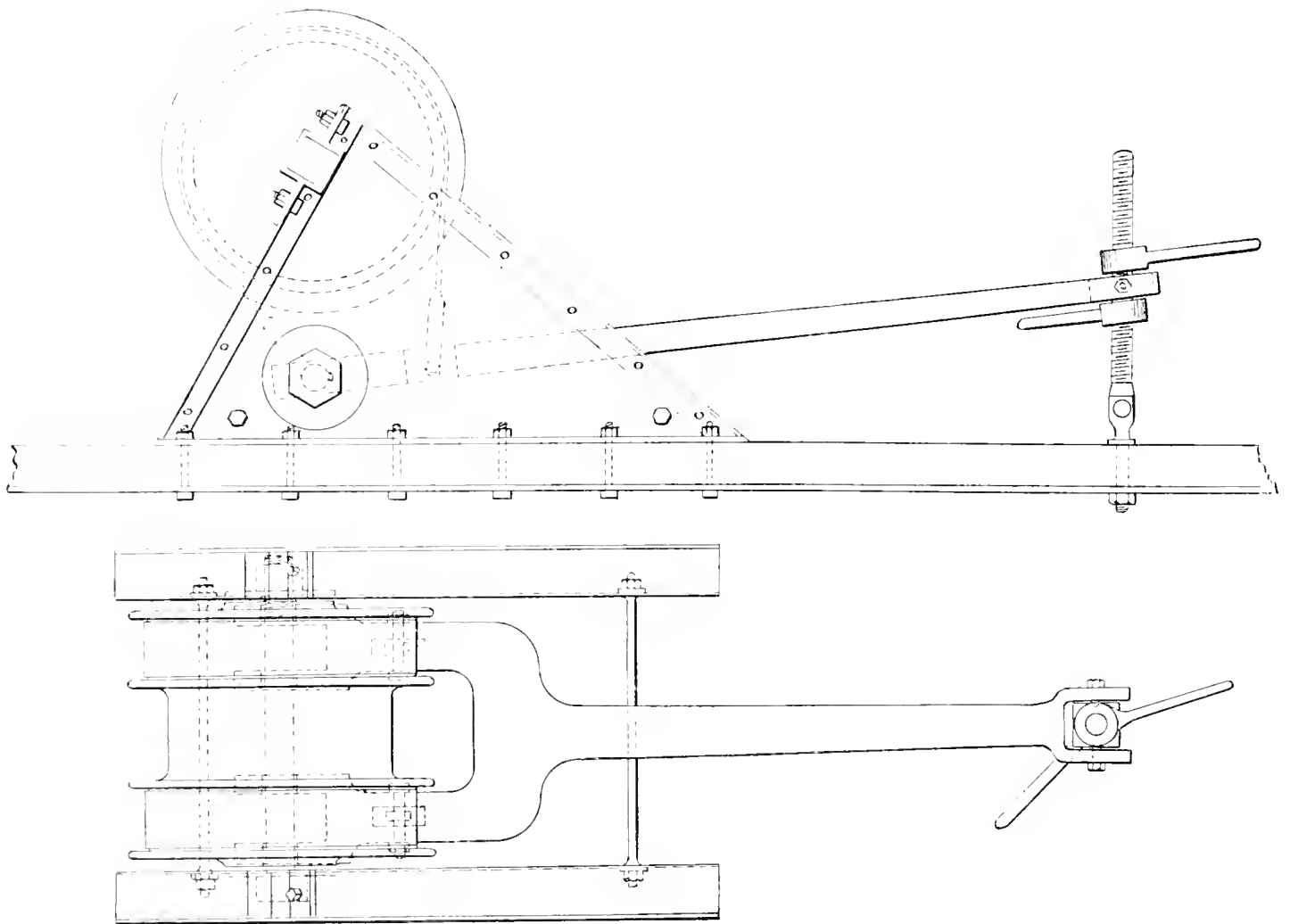

Fig. 3. Frictional stopper. Scale: 1/8.

revolution counter and by this means the amount of rope, that was paid out, was registered. It was necessary to make the stand of the odometer movable, in order to comply with the varying position of the line.

The frictional stopper *Z* (Plates I and II and Fig. 3) fitted at Surabaya in October 1899, consisted of a gunmetal cylinder supported on two brackets and provided with a double steel friction brake regulated by a lever and adjusting screws. The rope was taken five times round the cylinder. The chainstopper *M* (Plate I) was of the ordinary Harfieldtype with adjustable friction

gear. The rope was taken three times round this stopper which was lined out with brass plated wooden chocks. In order to fix this stopper the starboard anchor chain had to be removed.

The reel for hauling in the dredge-rope, (Fig. 4) weighed about 2000 kilograms, and

was constructed by the *Maschinenfabriks-Actien-Gesellschaft Vulkan* of Vienna. It was originally provided with an automatic winder, but as this device did not work satisfactorily it was removed. It was driven by an electromotor of 5 horsepower, supplied by the Electrotechnic Industry Ltd. Slikkerveer Holland, constructed for a current of 80 volts and a variable speed between 300 and 600 revolutions. By means of worm gearing of a ratio of one to thirty an intermediate shaft was driven, that carried a belt pulley,

from this the power was transmitted by belt to the first shaft of the reel, the belt could be easily removed when not in use. The motor was well raised above the deck to guard against getting wet. The starting resistance was fixed

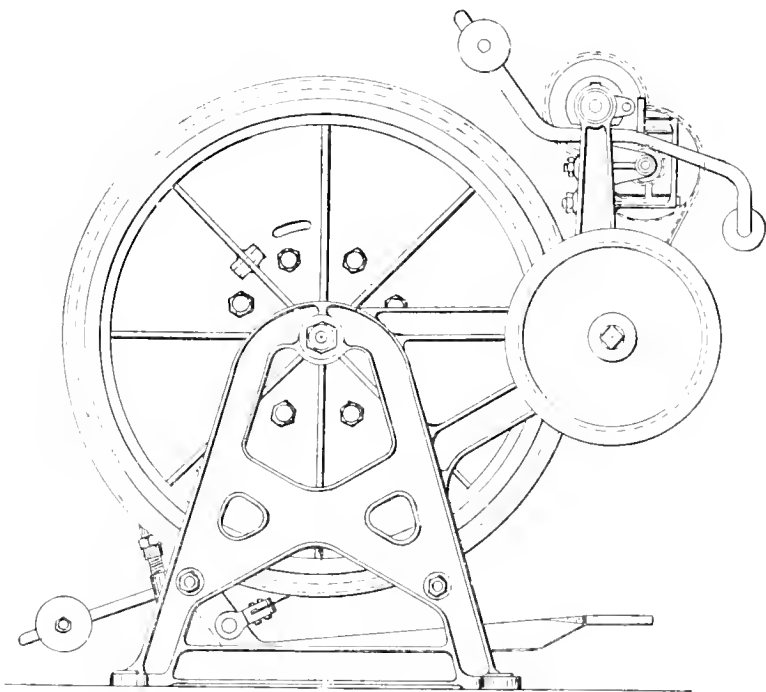
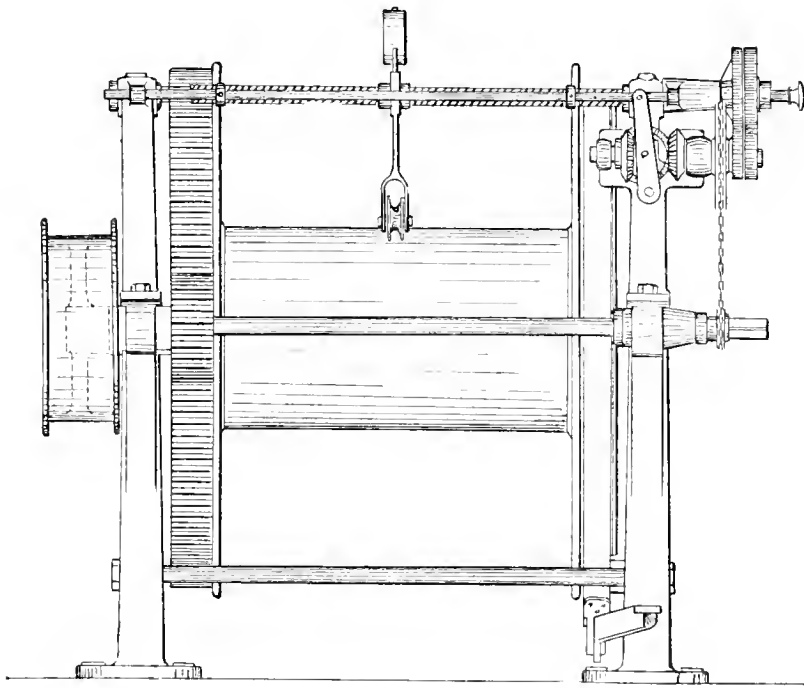

Fig. 4. Reel for dredge-rope. Scale:  $\frac{1}{20}$ .

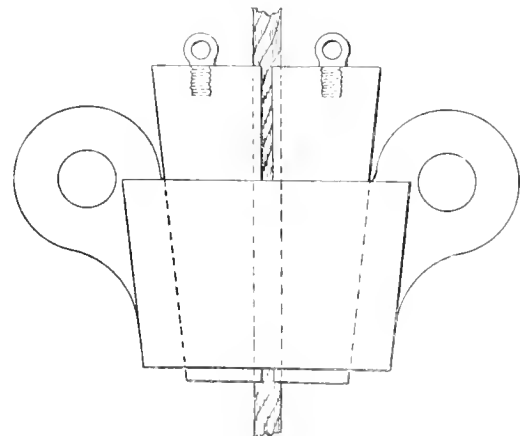

Fig. 5. Stopper for dredge-rope. Scale:  $\frac{1}{3}$ .

overhead to the deck above. The dredge-rope 10000 metres long, was wound on the drum at Amsterdam, in order that the efficiency of the electromotor and of the reel might be tested together.

The dredge-rope stopper (Fig. 5) consisted of a hollow iron cone provided with two lugs





If more than one day was spent at a place of anchorage the steam launch was generally made use of, and after finishing the scientific operations it was often used for hydrographical work. For both these purposes native vessels, called sampans, were often utilised. These were purchased on the voyage.

As might be expected in this part of the archipelago it happened occasionally that there was no anchorage at the place where we had decided to stop, at least not anchorage in the usual sense of the word. The voyage was then either continued, as for instance after touching the Widi-group to the east of Halmahera, or else we continued to drift, as we did when near the island of Kabia (Baars island), in the western part of the Banda Sea.

Sometimes the chief of the expedition thought it advisable in the interest of the work to make a somewhat prolonged stay at a place of great depth in which case the anchor was attached to the dredgerope. Thus, for instance, we spent three days from November 1 to 3 on the westcoast of the island Binongka with 500 metres of rope let out, the anchor lying in coralsand at a depth of 278 metres, the distance to the nearest coastreef being about 400 metres. In the same way we stayed on the south side of the Lucipara group in the Banda Sea, from November 8 to 11, with 1000 metres of rope let out, the anchor lying in stony ground about 1500 metres from the nearest reef. At this place whirlpools were formed with every change of the tide. It was probably owing to these whirlpools and to the rocky nature of the sea bottom, possibly also owing to some extent to the heavy ballast with which the rope had to be weighted at a certain distance from the anchor, that we were unable to free the rope from the bottom and so, unfortunately, lost the anchor and a piece of the rope.

On these occasions or when the ship was drifting, the officers as a matter of course took their turn in the night watch and steam was kept up. Fortunately for the expedition when we were sailing in parts of the Archipelago where the west monsoon prevailed or was due, this wet season passed over quietly.

The average speed of the ship was fixed at 7 or 8 knots per hour, thus enabling us to economise coal and not unduly tax the native stokers. As far as could possibly be arranged one engine only was used while the dredging was in progress.

#### REMARKS RELATING TO THE APPLIANCES AND IMPLEMENTS FOR DEEP-SEA EXPLORATION AND THEIR MANIPULATION.

The best works on sounding and dredging were consulted, particularly those of TANNER<sup>1)</sup> and SIGSBEE<sup>2)</sup>. As the nets, thermometers etc. in use were similar in almost every respect to those now generally used in deep-sea exploration, we may take it for granted that the working of them is understood, and the following remarks therefore refer chiefly to the peculiar conditions

1. Z. S. TANNER, Deep-sea Exploration. Bull. U. S. Fish-Commission, XVI, 1897.

2. CHARLES D. SIGSBEE, On deep-sea sounding and dredging, Washington, 1880.



of the East-Indian Archipelago, as regards sounding and dredging, and to the working of such instruments as have only lately come into use or of which little is known as yet.

The working of the appliances for the paying out, dredging and hauling in of the bottom nets is sufficiently explained in the description of the Plates I, II and III. Experience has taught us that for the successful working of the nets it is not safe to trust to the ordinary ship's fittings and gear, unless they have proved by practical trial beforehand that they are suitable for the purpose intended. For instance we decided to dispense with a specially constructed steamwindlass with stoppers on account of the very limited space on deck. Had we however foreseen the trouble caused afterwards by the use of the existing capstan and stoppers this objection would scarcely have been taken into consideration.

For one thing it was a most difficult matter to regulate the speed of the dredge-rope, when paying out; and when hauling in the speed was not as quick as we had expected. Sometimes it ran out much faster than anticipated, at other times, with very deep soundings, the strain put upon the capstan threatened to be too much for it. The ropes, winches, electromotor, and other instruments gave every satisfaction, and in many cases we succeeded in overcoming the difficulties just mentioned.

The difficulties due to the peculiar conditions of the East-Indian Archipelago as compared with those experienced in the open ocean, are the following. In the Archipelago the bottom of the sea presents as much variety in levels as the dry land, and this explains how it is that the depth at which the net reaches the bottom, sometimes varies so much from the depth indicated by the sounding line. It is therefore of the utmost importance that the net should reach the bottom as near as possible to the place where the sounding was made. Before beginning to dredge we had carefully to note the effect of currents and winds upon the motion of the ship, and after the sounding had been taken we steamed away from the point to a distance of a few miles. The net was then let down while the ship slowly steered back to the sounding place. The choice of the starting point naturally depended upon wind and current and upon the approximate speed of the ship during the letting out of the rope, and the length of time it would require to reach the bottom.

In the Archipelago the constancy of the currents cannot in the least be relied upon, because it is dependent upon tidal currents of which very little is known, and which sometimes are very strong. Changes in the current, taking place after the rope is let down or while the dredging is in operation, often have a most undesirable influence. For apart from the possibility of the net reaching the bottom at a different depth than had been calculated upon, it may happen that the course fixed upon is no longer favorable to the free play of the rope. The speed of the ship also may become considerably faster or slower than arranged for, according to the variation of the current. These circumstances may cause the net to tear, or to be kept floating; they may also spoil the dredging, not sufficient area of ground being covered. It will therefore be seen how important it is that the position and the actual course and speed of the ship over the ground should be controlled as accurately as possible. In many cases we did so successfully by use of the sextant, by constantly verifying the modifications in the angles of suitably chosen points while the net was being paid out or drawn in.

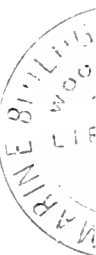

As already mentioned the swinging boom was always carried on the starboard side, as the arrangement of the awning did not permit of it being constantly changed about. It was proved however that on account of the variableness of the currents in the Archipelago, it would be advisable to be able to draw the net from either port or starboard. For not only must the rope swing clear of the ship, but the net should also be kept in the direction of the shallower rather than of the deeper water, which direction may be judged fairly accurately in the Archipelago. When the boom is only fitted for one side it is not always possible to comply with both these demands. As a rule the course steered when dredging was such that the current met the ship on the starboardquarter. The trawling was always done with the ship steaming ahead, as this insured a steady course, the free play of the rope, and the covering of a good distance.

When dredging near the coast and reefs, steep inclines were of frequent occurrence, and it was found that owing to the nature of the bottom on those inclines, the ground nets often ran great risk of being torn or caught. When dredging or trawling in such neighbourhoods it is therefore always advisable to drag the net only over short distances at a time, and bring the ship carefully over the place where the net lies, and when this is lifted from the bottom and during the process of hauling it in, the ship should steam slowly back into deeper water.

The nature of the bottom in the Archipelago, puts a great strain upon the nets. In shallow water and at moderate depths coralsand is frequently found. At greater depths the ground is often rocky, with boulders and pumice-stone, while at all depths fair sized tree trunks are to be found which naturally play havoc with the nets.

Finally the mud, even that found at the greatest depths, is generally far more tenacious than that found in the open seas owing to it consisting almost exclusively of calcareous or silicious remains of former living organisms. Where this kind of sediments is found in the Archipelago it is always mixed with a considerable amount of other elements, chiefly mineral, originating from the coast. Such terrigenous sediments are characterised by their tenacity and consequently the mud passes with difficulty through the meshes of the nets. Sometimes the net becomes filled with mud in a very short time, and this involves not only the risk of the net being broken, but the accumulated soil keeps the mouth of the net open, allowing the animals which are caught to easily escape again.

Bearing in mind therefore the nature of the sea-bottom in these parts, it is of the utmost importance to see that the nets are in good condition, and also to avoid paying out too great a length of rope, so as to obviate as far as possible the too rapid filling of the net.

On the other hand there is the danger of the net not reaching the bottom, and whether it has actually touched the ground or not, is not always easy to ascertain. Neither the indicator of the dynamometer, nor the feel of the hand, nor even the slant of the rope are sufficiently definite indications, in the case of very great depths. With regard to the first of these it has happened that the dynamometer showed no sign of the bottom having been reached, and yet the net afterwards proved to have dredged well. As for the second, it has been noticed that with a great length of rope paid out, the vibration of the rope with floating net can not be distinguished from its motion when dredging at a great depth over level and soft ground.

Perhaps in such cases the slant of the rope, controlled according to the directions of TANNER is the most reliable indicator as to whether the bottom has been reached, provided

always that the depth has not perceptibly increased, and that no special influences of current have been at work.

Almost all our trawlings or dredgings were preceded by a sounding. The various depths indicated on the charts were not often trusted to. In the East-Indian Archipelago it is never very safe to do so, unless there are reliable landmarks, by which the soundings of earlier and later dates can be localised beyond dispute. Owing to the many inaccuracies in existing charts and the unavoidable incorrectness of localisation arising therefrom, it is quite within the range of possibility to imagine that one has reached the point where a previous sounding was taken, while in reality one has come to quite another place; and a difference of a few miles may make a great difference in the depth of the sea floor. As an example we may take Station 177<sup>1)</sup>, where a depth of 1633 metres was registered only three miles away from the place, where the chart registered 1211 metres of mud floor; the depth during the dredging therefore, gradually decreased to 1300 metres. This place also brought some curious sediments to light.

The Station 271, situated immediately West of the Aru islands may serve as an example of a dredging in which the indications of the chart were followed with good results. We steamed from our sounding place, where we had found a depth of 1788 metres, in an E. N. E. direction, steering towards the point where the "Challenger" had found a depth of 1536 metres. The rope was stopped at 2240 metres and the net touched ground at a depth of about 1600 metres. When the dredging was concluded the depth had decreased to 1520 metres.

The greatest depth at which a successful haul was made, was registered at 4391 metres (6 November, Station 223). About 800 kilogrammes of mud were brought to the surface. It was a heavy strain on the capstan, but on the whole the operation was successful. One of the booms of the trawl, a tube 2<sup>1</sup>/<sub>4</sub> inch in diameter of 6 millimetres thickness of metal was entirely collapsed and split owing to the enormous pressure of the water. This was caused by the tube being air- and water-tight with iron caps fixed on the ends.

The large vertical nets were also worked from the dredge-rope. To insure their going straight down to the bottom, the lower part, below the reservoir was weighted with a ballast of 20 kilogrammes, and just above the swivel joint a weight of 30 kilogrammes was fastened to the rope. The letting out of those nets was at a rate of from 30 to 32 metres, the hauling in at a rate of 15 or 16 metres per minute. At moderate depths we fished sometimes with the vertical net, which was provided with an electric lamp connected with the ship's conductor.

The quantitative Plankton-net was worked by the rope of the depth registerer, on the poop of the ship.

For the fishing with closed nets we used our Le Blanc sounding-machine. It was provided for this purpose with a separate heavier barrel round which 600 metres of steel rope of 6 millimetres diameter was wound. As the weight of this rope was so much greater than that of the sounding line, two stronger springs were added to the stopper to be used with this rope. But as the constant changing about of the springs was awkward, the necessary extra pressure on the footreel was procured in a much simpler manner by a handspike pressing on the lever of the reel.

1) For stations see List of stations in: Siboga-Expeditie I. MAX WEBER: Introduction et description de l'expédition.

For the study of intermediate depths the Fowler-net was always used. A lead of 3 kilogrammes was suspended from the horizontal axle of the closing apparatus, to prevent the gauze net from being forced up too much, during the letting down of the net, and thus not keeping clear of the apparatus.

The drop weights of the Fowler net were found to fall respectively at the rate of 0.5 metres per second (for the large weight of 16 Engl. lbs), and 1.0 metre per second (for the small weight 4 Engl. lbs). HENSEN'S horizontal cylinder was often used. It was towed aft by an ordinary rope. We slowed down when lowering it or hauling it up, but while working we had a speed of from 3 to 8 miles. The depth at which this net was dragged, could be controlled to some extent by the position of the tow rope and by regulating its length.

#### REMARKS ON THE USE OF DEEP-SEA THERMOMETERS.

The use of the deep-sea thermometers with which H. M. "Siboga" was equipped showed some peculiarities which it may be of interest to note. While working with Negretti and Zambra reversing frame, made at Copenhagen, attached to the sounding line it happened occasionally that although the frame reversed correctly, the thermometer registered a temperature ( $26^{\circ}.2$  C.) which could not possibly be correct for the depth to which the thermometer had been lowered (fully 2600 metres, and another time 4000 metres in the Ceram Sea).

As it was absolutely certain that the instrument had had a continually descending motion from the surface to the required depth, and as the thermometer acted quite correctly both before and after the experiment, there is but one way to account for the untimely reversing of the frame. The sounding rope which was spun with a lefthanded twist being weighted with leadballast and thermometer, together amounting to 30 kilogrammes, may on going down experience a revolving motion due either to the natural untwisting of the line or to the screw-like action of the twisted wire of the line in passing through the water, the water acting as a nut. Now seeing that the pitch of the small screw propeller of the reversing frame is also righthanded it is clear that if the frame revolves faster than the speed due to the pitch of the screw the result will be that the frame will overtake the propeller and cause the safety pin to be unscrewed and the thermometer to be untimely released.

The screwthread of the reversing frame is righthanded. If the frame had only a downward motion the loosening of the screw would be impossible on account of the waterresistance, but the revolving of the frame upwards, will cause the screw in the frame to turn downwards, i. e. unscrew, because the wing of the fan of the screw, furthest away from the wire feels the effect of the swinging most acutely. Now if the influence of the revolution caused by the friction of the wire, is greater than that of the friction of the descent, it is clear that the screw must release the frame which consequently reverses.

It must also be borne in mind that at the beginning of operations the rate of descent is comparatively slow, while the rate of revolution may be very considerable, and that the

screws of the reversing frames needed but 2 or 3 turns to release their hold. Probably in the case here referred to the frame reversed at a depth of from 30 to 50 metres.

After this occurrence, and after the above explanation had been found for it, piano wire was substituted, when both frame and thermometer at once did their work properly. But now another difficulty arose, no less serious than the former, which also had its origin in the construction of the reversing frame, and which was not found out, until the frame had been used several times, and after the loss of a lead and a thermometer.

A sounding was made with a Negretti and Zambra frame. The object being merely to ascertain whether the depth averaged 2000 metres, and the wire broke when the thermometer had been brought up to within 15 metres of the surface. A careful examination of the broken end of the wire showed that it was twisted off by a lefthanded revolution.

The explanation of this accident can only be found in the fact that the screw of the reversing frame, being released when the hauling up commences, is afterwards locked, and continues so during the remainder of the ascent with the result that frame, wire, and lead assume a lefthand revolving motion, due to the reaction of the propeller on the frame.

At first the twists are divided over the entire length of the wire. But when the lead has come nearer to the surface, and the speed of heaving in the wire is gradually reduced for the sake of safety, the twists in the wire, which has now become quite short, increase rapidly, as the lead continues revolving, presuming that the weights have not been dropped; the wire eventually becoming twisted to such an extent as to prove fatal to the weakest point in the line, i. e. that portion of it which is fastened and hidden in the splice, and hence cannot be kept under regular control. Here it was that the breakage occurred.

A careful consideration of the causes of these two accidents led to the following conclusions.

1. When using a twisted wire-line for reversing thermometers on the Negretti and Zambra system a righthanded screw should have a righthand-twisted line, and a lefthanded screw a lefthand-twisted line. This matter should be attended to when the instrument is constructed. If circumstances do not permit of this it is urgently necessary that the speed of descent should be and remain great from the moment that the thermometer touches the water. Any hitch in the working of the sounding machine might cause the untimely reversing of the thermometer. At all events it is desirable that the screw should not be able to release its hold too quickly, certainly not till after several turns, and over a considerable distance. This can cause no appreciable difference in the registration of temperatures at great depths.

The reversing frame might also be improved, by an arrangement which would insure the screw's acting only with an upward motion regardless of revolutions due to the twistings of the line. This might be done by introducing a small horizontal hinged-plate, which when the frame is at rest would act as a catch on one of the screw blades, and which could only be forced out of position by the pressure of the water when the frame has an upward motion.

2. It is a great mistake to lock the screw in the reversing frame after it has been unscrewed in the hauling up; the screw should be able to continue to turn loosely, in the same manner as is done for instance in the waterbottle with thermometer, system PETERSSON.

PRIME BIO

## REMARKS ON THE LE BLANC-SOUNDING MACHINE AND ITS USE.

*Description of the machine.*

Referring to the illustrations (Fig. 7, 8, 9) it will be seen that the machine consists of two vertical frame plates firmly connected together by staybolts and angle irons and fixed on the deck. The vertical frameplates carry a shaft *B* on which is keyed the winding drum *C*. The shaft projects on the left-side and carries the pawl wheel *E* and the wire drum *D*. The wire drum is fixed on a separate boss in such a manner that it can easily be withdrawn and replaced by another. The pawl wheel *E* and the wire drum *D* are both free to revolve on the shaft. The external diameter of the wire drum without the line is slightly larger than that of the capstan.

The extreme end of the shaft *B* carries a coiled spring *G* which can be compressed by the adjusting wheel *F* against the loose boss that carries the wire-drum *D*. By means of the spring this boss is pressed against the pawl disc *E*, which in its turn is pressed against the flange *H*, both sides of the pawl disc *E* being fitted with leather rings to increase the friction. A pawl, which is carried on the frame plate works into the pawl teeth of the disc *E* and prevents it from revolving when the line is being payed out.

By this arrangement it will be seen that owing to the friction coupling the winding drum and the wire drum, although revolving in the direction, will not necessary revolve at the same speed.

When winding in the line the difference in speed is in direct proportion to the diameters of the drums. The speed at the periphery being kept equal by the line passing over both drums. This has the result of keeping the line taught between the one drum and the other to the extent of the force required to cause the wire drum to slip between the leather collars. The wire drum is fitted with a portable handle *K* to work it by hand when required.

Below the winding drum the guide pulley *L* is slung between two links *M*. These links allow it a certain amount of vertical motion, which is resisted by the two springs coiled round the vertical rods *S*. These rods pass through the crosspiece *Q* and are connected together by a crosshead to which the brakeband *A* is attached. The other end of the brakeband is held by the nut *O* adjustable by the handwheel *N* and the screw *P*. The brake-band consists of a steel strip lined with wood. In front of the winding drum there is another pulley *I* which drives the counter *Z*. The pointer of this counter is adjustable.

At the front of the machine there is a vertical erection *LJ* carrying at the top the double pulley *Z* in which is suspended the ballast-scale *W* fitted with guide rollers *bb*, working in two suitable channels. The upper part of the scale, carrying the pulley *Z*, is connected by means of a dynamometer *d* with the lower part, which in its turn is connected to the baseplate by means of a coiled spring working in the cylinder *a*.

A number of cast-iron discs is supplied wherewith the weight in the scale can be adjusted.

On the righthand side of the machine there is a small single-cylinder steam-engine with flywheel *c* and shaft *h* fitted with the sliding pinion *e*, which drives the winding drum *C* by means of the toothwheel *g*.

At the back of the machine there is a light revolving Davit *l* carrying the guidepulley *u*.

The Davit can be adjusted with the handle *P*.

The lower part of the guidepulley *L* runs in a small sheet-iron tank, not shown in the engraving.

The necessary oiling arrangements *IJ* are fitted where required.

*Run of the sounding-line.*

This line consist of steelwire 0.9 mm. diameter and is wound on the wire drum. From here it runs over the top-guide-pulley *u* to the winding-drum over which it is passed five turns, from there over the guide-pulley *L* to the counter pulley *U* and upper double pulley *Z*, from there to *Z'*, upwards again to the double pulley *Z* and from there to a Davit and over-board.

The whole apparatus was placed on the extreme port side of the bridge. The outer Davit was fixed to the fixed shield-plate of the 3.7 cm. gun.

The sounding lead is attached to the wire by a light ground line of about

six metres long. At the upper end of this ground-line there is a small lead weight of two to three kilograms. This ground-line and auxiliary weight is to prevent kinks taking place in the wire, which is very apt to occur and to cause the breakage of the line.

Experience proved that a length of six metres for the groundline works well.

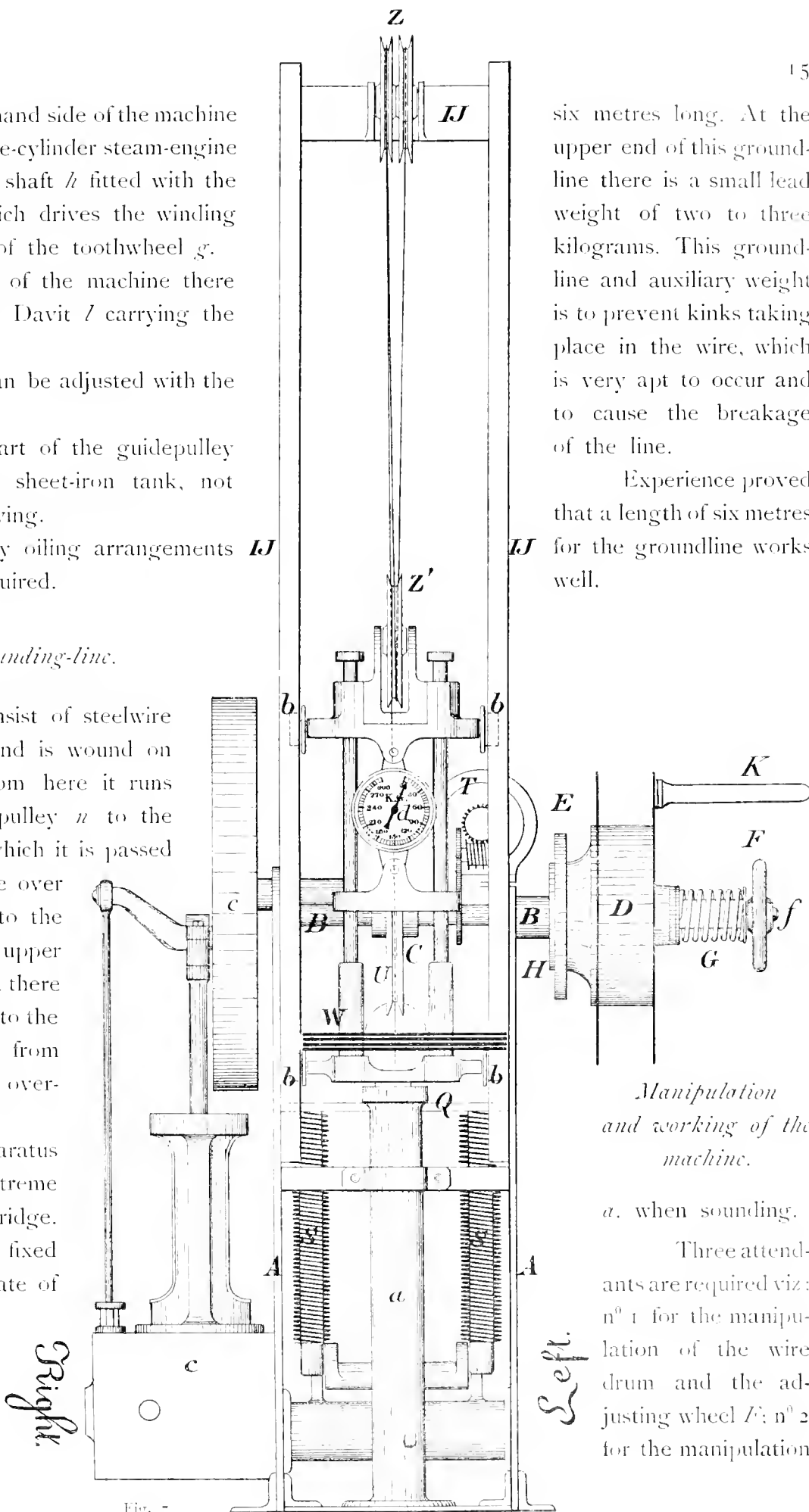
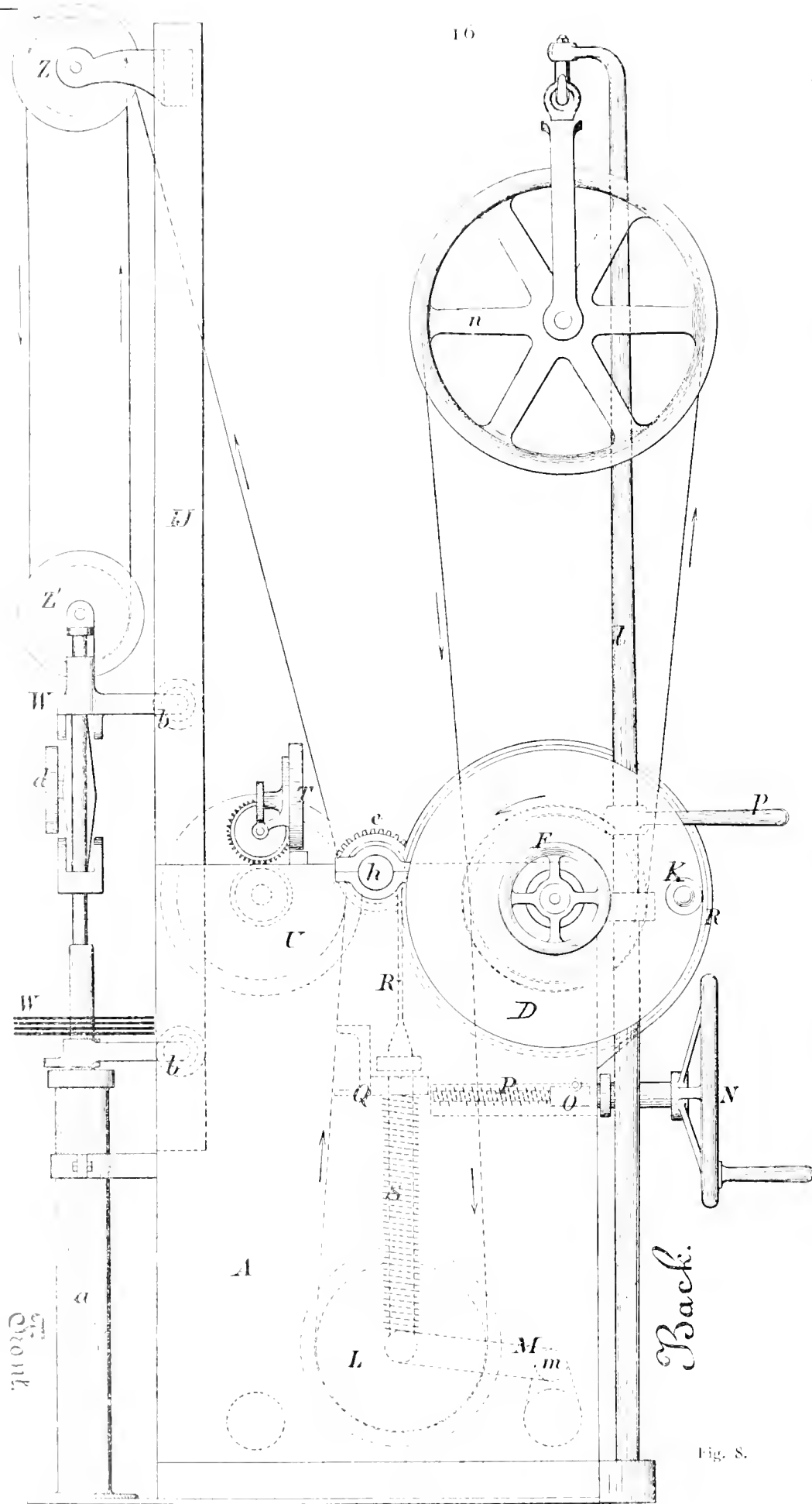

Fig. 7.

*Manipulation and working of the machine.*

*a.* when sounding.

Three attendants are required viz: n° 1 for the manipulation of the wire drum and the adjusting wheel *Z'*; n° 2 for the manipulation



of the brake and the steam-engine; n<sup>o</sup> 3 for the adjustment of the weights on the ballast-scale.

The sounding-lead when ready for use is lowered over-board while the ship is stopped. At first while paying out when there is but little strain on the wire and the weight in the scale comparatively light, the scale will begin by striking the upper stops. The pulley *L* is thereby raised owing to the springs *S* being compressed. The brake *R* is hereby relaxed and should now be gradually released until it only just touches. The adjusting wheel *F* can now be loosened until the lead begins to descend.

The pawl wheel *E* during this descent being kept at rest by

Fig. 8.



the pawl. If necessary, the drum can be started by hand as there is sometimes a tendency of the leather discs to adhere to the wire-drum-boss if it has been standing unused for some time.

Owing to the paying out the tension on the wire is reduced and the ballast-scale descends, at the same time putting on the brake *R*. But as the weight increases, due to the amount of wire paid out, it will be necessary to add weights to keep the scale in midposition and the brake-band adjusted in proportion.

A suitable speed of the wire was found to be about 2 metres in the second.

This speed is not only regulated by the brake-wheel *N* but also and principally by the friction-wheel. But since the friction-wheel revolves with the shaft, an exact adjustment is difficult

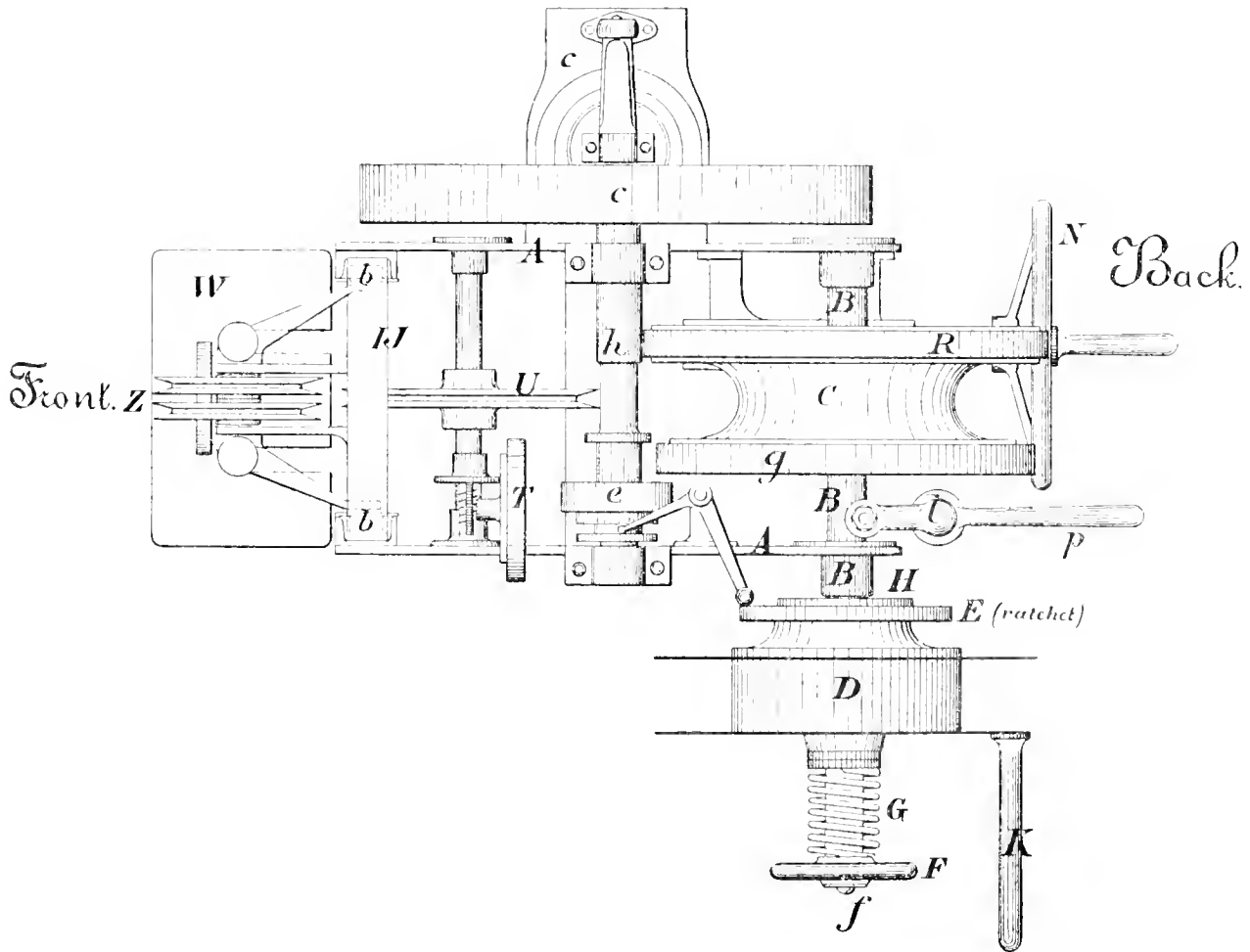

Fig. 9.

to be obtained, it has therefore been found necessary to regulate the friction by other means.

Attendant n<sup>o</sup> 1 presses a piece of leather against the outside of the inner flange of the wire-drum, thereby forcing it against the friction-wheel whereby he can regulate the friction to a nicety. Especially when the ship is in motion is this necessary so as to insure a correct working of the ballast-scale. The purpose of this scale is two-fold. In the first place if the ship is rolling and pitching it falls and rises accordingly, thus keeping a constant strain on the wire; in the second place, the moment the lead touches the bottom it is intended to take up the slack of the rope and in its descent releases the springs *S*, thereby tightening the brake-band

and automatically stopping the machine, this being the sign that the lead has struck the ground.

Before however the machine has stopped there will be a certain amount of wire paid out, from the time that the lead strikes the ground, and this slack is taken up by the scale in its descent. At the same time the attendant presses the wire drum firmly against the friction disc, and compresses the coil spring  $G$  with the adjusting wheel  $F$ .

The counter can now be read off, giving the depth in metres if the wire is vertical. It should here be noticed that during the paying out of the rope the adjusting wheel  $F$  is at rest. A point to which special attention should be paid is that the tightening of the wire-drum serves also to regulate the tension of the rope between the wire-drum and the winding-drum, thus preventing the wire from flying out of the top-guide-pulley and getting damaged. The man attending to this has therefore to keep a sharp look-out that the scale does not strike the stops, which would cause a dangerous jerk in the wire. The man at the brake regulates it and takes care that the wire is wound fairly on the drum without the strands overlapping one another.

It was found that even with a well oiled winding-drum the rope would sometimes run up the high side of the drum and suddenly shift back to the middle thereby causing a momentary slack in the rope and a jerky motion of the brake, consequently an unregular paying out of the wire. To remedy this fault an iron lever was fitted and fixed to the machine which forced the wire to keep in the centre of the drum during the winding.

While sounding, this lever was put to the left and when hauling in, to the right of the coils and it answered very well. Of course the proper adjustment of the brake as well as the required weights in the scale are matters which can only be found by experience.

To find the speed of run it is only necessary to observe in what time a certain length, say 100 metres, is payed out. Experience soon teaches this to be done by sight.

The Le Blanc machine requires a rather heavy lead on account of the comparatively great friction which has to be overcome. Especially when a great depth is anticipated it is advisable to have a heavy lead, because otherwise the amount of rope run out would take up too great a proportion of the total tension and reduce the chance of the machine being stopped automatically, especially with a slight pitching of the ship, for it must be born in mind that the sinker of the stray line must never be allowed to strike the bottom for in that event the line kinks and breaks, on being hauled in.

For the same reason a weight of 25 kilogrammes is but scarcely sufficient to overcome the friction of the machine in case water-bottle and thermometers have been attached to the lead itself.

Before beginning to sound the machine should be oiled and the indicator set to the depth at which the lead is suspended below the surface of the water. It should be ascertained that the pointer of the indicator is tightly fixed on its spindle to prevent false indications.

#### *b.* When hauling in the line.

Besides the three persons, above referred to, two more assistants are needed to attend to the oiling of the wire with oiled rags held in their hand. As soon as the lead reaches the bottom and the register is read off, the brake and the friction adjusting wheel are released and

the winding-drum is worked round a few revolutions until the lead is lifted off the bottom. This will usually cause the scale to be raised and remain suspended unless the depth is insufficient. Should the scale however remain tightly pressing against the upper stops, the probability is that the weights have not been dropped. To accomplish this the lead is then lifted up about 15 or 20 metres and lowered once more. If however the bottom is of a soft muddy nature even this will not accomplish it because the weights will sink in the mud and the decrease in tension will not take place suddenly enough. The slow descent of the scale will indicate this.

If the bottom is hard the scale will sink abruptly and then the adjusting wheel has to be screwed up sharply to prevent the wire from slipping out of the top pulley.

In case of soft muddy ground however the brake acts before sufficient slack is given to the rope to detach the slip block from the lead (or as in case of the SIGSBEE lead to work the sliphook). The slipblock of the Le Blanc lead is fairly light and with the weights resting on the soft ground there is scarcely sufficient power to pull it down farther. If the waterlayers through which the wire passes have different currents a certain tension is maintained in the rope which prevent the slipping apparatus from working properly. In this case the only chance of dropping the weights is as follows.

About twenty five metres of line is hauled in either by hand or by steam, some-one stands on the ballast-scale to keep it right down, the line is now paid out again at the normal speed but a few metres more are allowed as soon as the lead has touched the ground, this is observable by the reduced speed of the line, the less amount of tension as well as the indications of the counter. The brake can be somewhat loosened during this operation.

The stray-line and slipblock are now free to sink lower, even should the lead and weights have already entered the mud.

Now, provided the strops with which the weights are attached to the lead are not too stiff and not too tightly fixed, both lead and weights will detach themselves from the slipblocks and remain behind when the wire is hauled in.

As soon as the lead strikes ground the winch is started to run free; after the lead has been lifted by hand and the weights slipped, the winch is put into gear and the line hauled in with the scale heavily weighted. In stormy weather the scale must however not be weighted quite down: if the sea is rough it is better that the scale balances below the centre and prevents it from striking the upper stops by hand.

With a lead of 15 kilogrammes or less, 75 or 80 metres per minute was found to be a suitable speed.

When hauling in the line, the brake is set entirely loose.

The adjusting-wheel should be set to keep a moderate tension between the two drums.

Too much tension might damage the wiredrum: too little tension is apt to lead to irregularities in the winding. The result of this being that at the next sounding the wire may leap out of the top-guide-pulley.

Neat and regular winding is a very important point.

During the hauling in of the wire it is passed through an oiled leather held in the right hand; while the left hand works the adjusting wheel.

This wheel is apt to work loose owing to the vibration of the machine to be observed by the reduced tension in the wire. To prevent this taking place it is advisable not to oil the adjusting screw but simply to keep it free of rust.

During the hauling in the action of disc and other parts is as follows.

On screwing up the adjusting-wheel the friction is increased between the disc and cylinder which carries the wiredrum. Now seeing that the circumference of this drum is somewhat greater than that of the winding-drum and that it increases with the amount of wire wound on it, it necessarily must slip, due to the amount of difference in circumference with that of the winding-drum and the tension of the wire between these two drums is regulated by the amount of friction between them.

When the indicator shows that the lead is near the surface, the speed is reduced or the winch stopped and the rest done by hand, although after long practice it is possible to use the winch to the very last. In which case the steam is shut off when there is about 20 metres of wire out and the accumulated power in the flywheel does the rest. At the proper moment the brake is applied and the flywheel stopped by hand. The lead is then hauled on board.

During the hauling in the weights on the scale are gradually reduced unless the ship is rolling heavily as it is then better to leave them on and keep a sharp look-out on the position of the scale.

With single wire the indicator returns very nearly to zero but with a spun line there is usually a certain amount of stretching. It is always advisable not to trust entirely to the indications of the counter but to watch the line as well and give direct warning should the weight unexpectedly appear before its time. In this case it is of advantage that the ship be steaming ahead as the amount of wire in view is then increased.

### *The sounding Wire.*

On the Siboga the wire used was 0.9 millimeter diameter manufactured by FELTEN & GUILLAUME of Mühlheim on the Rhein. The breaking strength was between 150 and 180 kilogrammes, it is however advisable not to put a greater strain upon it than one half of this or say a maximum of 90 kilogrammes.

Thousand metres of this wire weigh 5.1 kilogrammes and cost *f* 16.21.

The original supply was one roll of 6000 metres and one of 9000 metres but later on another roll of 5000 metres was supplied.

The sounding machine had one drum which could carry 10000 metres of this wire and another drum that could take 9000 metres of twisted wire.

To wind the wire from the wooden reels on which it is sold on to the wiredrum, the reel is placed on a horizontal shaft at some distance from the machine. The end of the wire is wound five turns round the winding-drum, then passed over the top guide pulley on to the wire drum. The steam winch is started and the proper tension put on by the adjusting-wheel.

The wire of 6000 metres had one joint and that of 9000 metres had two joints made according to TANNER'S system<sup>1)</sup>. When the splices were passing the winch was slowed to allow them to be carefully inspected and special care was taken to prevent damage to them.

Besides this single wire galvanised steel rope was used consisting of 7 wires of 0.55 millimetres giving a total diameter of 1.65 millimeter. This wire supplied by the same makers weighed 13.75 kilogramme and costs *f* 21.— per thousand metres. The breaking-strength is somewhat less than the single wire of 0.9 millimetre. 9000 meters of this rope was wound on a special drum of larger diameter. The removal of the drums on and off the sounding machine was easily done. The heavy drums were assisted by the david and tackle block.

The wire rope was originally supplied in one length without any splices. The advantages and drawbacks of the two kinds of wire are the following. The single piano-wire is lighter, stronger and more durable as long as it does not kink and it gives less resistance in the water but the chances of kinking and loss of sounding apparatus are greater. The rope does not kink so easily and even then does not break. On the other hand it sometimes happens that one of the wires breaks, causing damage and delay as in this case the rope has to be cut and spliced.

It also takes up much more plankton, carrying it on to the drums, which undoubtedly is apt to cause rusting and thus lessen, its durability. This plankton mixed with the zinc-oxyde of the wire adheres in a strong layer on to the pulleys and drums, causing considerable friction and irregular running.

There is also a danger of the assistants who let the wire pass through the oiled rags held in their hands, getting hurt by loose pieces of wire which may pierce the rags in their hands. As soon as they feel any loose wire the machine is stopped and the wire repaired.

The splicing of the wire is performed in the same manner as ordinary rope. Only that the ends of the wires are not all cut off at the same distance this gives a more gradual increase in thickness to the splice. The splice is then about 200 millimeters long and is wound over with fine wire the ends of which are carefully buried in the rope.

#### *The Sounding leads.*

The sounding-machine had two deep-sea leads with cocks (sondeur à clef du PRINCE DE MONACO Fig. 10). One of these was lost at the beginning and the other at the end of the voyage.

The cock-lead consists of a fairly heavy hollow gunmetal tube increased in diameter at the lower end to hold the cock. The inner diameter of the tube is 50 millimeters. Above the cock

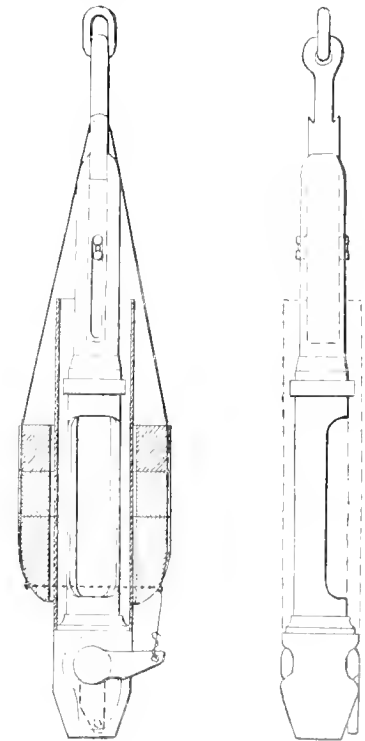

Fig. 10.

<sup>1)</sup> See J. S. TANNER, Deep-Sea Exploration, Bull. U. S. Fish-Commission, XVI, Washington 1897.

the one side of the cylinder is cut away over a length of 250 millimetres. Around this part revolves another thin tube or covering plate similarly cut away so that by turning this round, the opening can be opened or closed. For further protection an iron tube is passed over both and held in place by a screw. The external diameter of this iron tube is the same as that of the cock shell namely 103 millimetres.

The upper part of the gunmetal tube is of smaller diameter and provided with two slots, which determine the amount of movement allowed to the wrought-iron tube or slip-bolt.

The slip-bolt has two notches which project beyond the gunmetal tube when the lead is suspended in the position of descending. On to the projections formed by these notches the slings of the ballast-weights are slung.

The stray-line is looped to the link on the slip-bolt. When the lead has reached the bottom, both ballast-weights and slip-bolt continue to descend; this slips the slings of the ballast-weights out of the notches, allowing them and the weights to fall off. As the lead is hauled up and the weights slip right off, the cock is shut.

The weight of the sounding lead is 15 kilogrammes.

Besides this type others were used, of simpler and lighter construction and fitted with butterfly valves for bringing up the bottom soil. For instance, a very effective deeplead was made from a piece of boilertube. For shallow depths an ordinary lead of 25 kilogrammes weight was used. This weight was found scarcely sufficient. There were further on board two SIGSBEE's leads with a conical valve. The slipping arrangement was also of a special construction. The bottom part can be unscrewed to remove the mud that has been dredged. The external diameter of the cylinder is 65 millimetres and the weight 2.7 kilogram.

The ballast-weights used were cast iron cylindrical and spherical rings, with a hole of 115 millimeter diameter. The weight of the cylindrical ones was 9.25 kilogram and that of the half spherical ones 13.25 kilogram.

To be able to use these same weights with the SIGSBEE leads, additional bushes were used of 110 millimetres exterior diameter with a hole of 64 millimetres and they weighed 7.75 kilogram.

In case of need any kind of weights may be employed such as projectiles, pieces of iron, tins of sand etc.

It is advisable always to hang them symmetrically to insure a vertical descent.

If the bottom specimen is for scientific use the cock lead is preferable, especially in muddy ground, because the hollow tube of the cocklead brings up an undisturbed cylindrical bottom specimen in which the different layers of soil are exposed in their natural succession. The only objection is that if the ground is hard or the cock fails to work it brings up nothing.

The SIGSBEE lead has the advantage of being light, although being made of copper it is apt to get damaged on stony ground. The chances of the slip arrangement not working when muddy ground is encountered, is about the same as with the other type. How to relieve the strain in the rope in such an event has already been explained.

## REMARKS CONCERNING SOUNDING WITH THE LE BLANC-MACHINE.

In addition to the directions given above, the following deserve consideration. A too sudden descent of the weighted scale should be avoided as much as possible, because it might cause a sudden slack between the wire drum and the winding drum. At the same time the movement of the scale should not be interfered with to much as its descent and the succeeding automatic stopping of the machine is the sign that the bottom has been reached, and it is most important that this should be accurately noted.

Especially in the case of a great depth when the rope is heavily weighted and the weight perhaps increased with thermometers, mistakes are easily made when there is a slight heaving of the ship.

It is also possible for the machine to be automatically stopped before the bottom is reached, simply on account of the motion of the ship. With the next heave of the ship the rope will recover itself, loosen the brake and start the machine again, unless under the impression that the bottom has been reached, the brake has been tightened. In this case there is a danger of the wire breaking, on the scale being lifted up and striking the upper stop unless the attendant loosens the brake in time.

If at a great depth and through the additional weight of waterbottles and thermometers, the friction under water is great and the decrease in weight on the lead, reaching the bottom is relatively small, the chances are that in a high sea the apparatus, on reaching the bottom will behave in the same way as mentioned above. It will then be very doubtful whether the bottom has been reached or not. Should the scale remain down, even although the machine starts working again then it is a sure proof that the bottom has been reached and in that case the wire should be hauled in somewhat.

If the lead is sticking to the mud the scale will be lifted. Should the scale fall and remain hanging half way, than this proves that the lead is off the ground and the ballast-weights dropped. Should the tension in the wire be appreciably reduced but the scale remain up, then the lead is off the ground (or out of the mud), but it is not certain whether the weights are dropped. If it requires much exertion to pull the scale down then it is probable that the weights are not slipped.

The different currents of the upper and lower water layers or the drifting of the ship by side-wind can increase the uncertainty of the ground being reached. In both cases and especially when the ship is rolling, even although the lead has reached the ground, the tension in the wire which is hanging in a bend can suddenly be sufficiently increased to restart the winch and to lift the scale. In this case there is every chance that the wire is allowed to run out under the impression that the ground has not been reached and thus cause the kinking and breaking of the wire.

From these remarks it will be seen that it is always advisable to use a heavy lead, when sounding in great depths with a heaving ship. The indication that ground is reached will

be more distinct and for this same reason the twisted wire requires a heavier weight than the single wire.

For more than one reason it is necessary that a vertical position of the wire close to the ship should be maintained. In the first place to obtain a correct depth by the counter. In the second place for the better working of the upper part of the wire. To make this clear it should be observed that a true vertical position of the wire is only possible if the ship is lying absolutely still as the whole mass of water in which the ship, wire and lead happen to be. As a rule this is not the case and owing to the different motions in the water the wire will be bent even although the upper end of the wire remains vertical. The indications on the counter will therefore always be more than the actual depth and it is impossible even to guess to what extent. In general it can be accepted that the fault is of no consequence when piano wire is used.

#### UPKEEP OF THE SOUNDING MACHINE.

The sounding machine should be kept in good condition, well cleaned and oiled. The sounding wire which is being used should be well dried by passing it through rag, and oiled by passing it through a second rag. The oil reservoir under the lower guiding pulley was seldom used. The original shape of this reservoir proved to be unpractical. The oil being thrown out by the action of the pulley in a very short time even after the addition of vertical plates to the front and back of the reservoir to prevent the oil being thrown out. The wire carries so much oil with it that on reaching the winding-drum gets thrown about and lost.

Experience taught that by the use of a dry and oiled rag, the oil being used being mineral, the wire could be kept in a good condition. After a whole year's use the piano wire showed no signs of wear. Even the twisted wire showed little or no signs of rust although several times some of the wires got broken.

New piano wire should be stored in a dry place and packed in water-tight oiled paper. From time to time the wire should be inspected any signs of rust removed and oiled afresh. Wire which had been used in the machine was stored in this manner with good results only with an occasional oiling.

#### THE MANOEUVRING OF THE VESSEL WHEN SOUNDING.

While sounding the object was always to keep the line vertical.

In many instances the direction and the approximate force of the current could be estimated fairly accurately.

Bearing these points in mind and taking into account the probable drifting to be expected, the ship was brought in a direction so as to minimise the chances of the rope deviating athwartships and rather to bring the line away from the ship than towards it.



If from previous soundings in the neighbourhood the action of the current was known, soundings were frequently commenced while the ship was moving ahead or astern. If no such information had been obtained the ship, after having been brought to rest in the surface water, was placed in the proper direction.

As soon as the line showed any deviation from the vertical the ship was manoeuvred according to circumstances.

One point which could be depended upon and which probably applies to all screw-steamers of the ordinary type was, that with the ship lying at rest in the wind, the bow drifted off and when steaming astern the stern veered round in the wind.

When only wind and waves influenced the vessel and there was none or very little current, it appeared as a matter of course to place the ship, at the commencement of the sounding, almost right before the wind, the wind striking the ship a few points on the sounding side.

Working one screw astern from time to time was then generally sufficient to keep the rope nearly vertical.

If there was but a slight current and especially when this was in the same direction as the wind, or if there was but little wind, it was found best to steer against the current and keep the rope vertical by steaming slowly ahead. It was hereby easier to keep a true course and to prevent the line passing underneath the ship.

When sounding in the Moluccan Archipelago in the east monsoon with a strong wind and current in nearly the same direction, a speed of  $1\frac{1}{2}$  to 2 knots had often to be maintained in order to keep the line vertical. Under such conditions the ship could not be steered sufficiently accurately with the engines working astern to prevent current and wind to come in from time to time on the wrong board, causing the line to get badly under the ship.

Working the screws in opposite directions is only effective in very calm weather. With the slightest breeze and any sea running, the ship veeres off and remains in a fixed position, which most probably was not the one wished for.

Even with the engines working at full speed the desired direction could often not be obtained. Much labor and steam are then uselessly wasted.

When much line is paid out, manoeuvring the ship on the same spot is of not much use as the horizontal movement of the wire is too slight in comparison to the length paid out. For with a strongly slanting long line, the horizontal distance between the ship and the lead is great and the principal question is evidently to reduce this distance as much as possible, or in other words, to keep the ship vertically over the sounding lead or to bring it back to that position.

Perhaps this object may sometimes be obtained by alternately steaming ahead or astern combined with the necessary changes in the ship's course, but this is an unpractical method, involving constant manoeuvring and a large consumption of steam, with the line sometimes trailing forward and sometimes astern. Not only is there a chance of the wire having a very slanting position at the moment the lead touches ground, but the tension in the wire is so irregular that the sounding machine works very irregular.

In order to ascertain what will be the best way to bring back the line to a vertical position, the first thing to do is to find out, approximately where the lead is with respect to the ship. From observing the deviation itself the influence of current and wind can be estimated; this being ascertained the ship is moved towards that point taking in to account the influence of the current and the wind.

The more accurate the changes of position in the wire are noted and corrected from the very first, the simpler the manoeuvring required will be, to bring about the desired result.

When the lead is being hauled in, care should be taken that it does not graze against the ship's hull or bilge-keels. A slant in the line is than an advantage as it also reduces the influence of the motion of the ship on the line. It is therefore preferable to steam ahead, during this process, and if possible in the course to be ultimately followed.

On this account the broadside position for sounding is not so suitable as it is not always possible to choose the most favourable course and the line runs a greater risk of fouling the ship or propellers.

With the machine stationed on the railing aft, any course can be steered and the line runs more free from the outer pulley.

If placed on the bridge, as on the Siboga, it is easier to keep watch over the position of the line and the manoeuvring of the ship is consequently simpler. On account of the great weight of the apparatus and the limited space available, it was placed as close as possible to the ship's side. The bridgedeck was at that point fitted with supports. Where possible it is preferable to leave some space at the front of the machine, this would greatly facilitate attendance to the ballast-scale.

#### OBSERVATIONS REGARDING THE SOUNDING MACHINE.

The Le Blanc machine proved very satisfactory on the Siboga. Fractures of the line and other casualties were comparatively few and to some extent due to insufficient training.

It is absolutely necessary to have a thorough knowledge of the machine as the automatic action cannot entirely be relied upon under all circumstances.

On board of the Siboga there was only a brief description of the apparatus giving little detailed information, so that the skillful handling had to be obtained entirely from careful practice.

The defects of the machine, which no doubt could be remedied, are the following.

1. The adjusting friction gear revolves with the wiredrum-shaft. This is objectionable, not only because an exact adjustment is difficult, but by the strong vibration there is a great chance of it working loose. An arrangement in which the principle of adjustment was maintained, but whereby the handwheel was at rest during the revolving of the shaft would not increase the cost very much, but be a great improvement.

2. The single-cylinder engine should be replaced by a three-cylinder triplecrank engine, properly balanced, so as to do away with the objectionable vibration.

3. The teethwheels as made, caused such a noise that it was difficult to hear the commands given. Accurately cut wheels with a true pitch with pinions of raw-hide might improve this.

4. The steel brake strap is too stiff, probably a strong leather one, also fitted on the inside with wooden blocks, would do better. The objections to the present arrangement is as follows. In order to let the line run out at a fairly high speed the strap must be loose. Now if through a heave of the ship the tension of the line is slackened, but for an instant, the spiral springs put the brake on. This is exactly what is intended, but the strap being so stiff it brakes the machine so much that with the next heave of the ship in the opposite direction, the tension in the line is suddenly too great.

Of course the brake can be unscrewed, but the result is that the line does not run out smoothly but with jerks. The scale also works jerky and may strike the stops, causing slack in the line between the winding drum and the wiredrum. Owing to the former having more momentum and maintain a more regular rate of revolution than the latter. It therefore gains upon the winding drum, causing the brake to act too strong.

5. The arrangement of the top- and outer guiding pulley does not offer sufficient security against the danger of the line getting out and jamming between the sides of the pulley. This could be improved by fitting proper guides, accurately fitting, round the edges of the pulleys.

The cock-lead worked quite satisfactory. Its good and bad points in comparison with others have already been mentioned.

During the scientific expedition of H. M. Siboga 181 soundings were made with the Le Blanc machine of which 129 were more than 2000 metres and 52 less. The greatest depth reached was 5684 metres. The machine worked well throughout, no defects of any importance having taken place. The flanges of the smaller wire-reel were slightly strained and bent out, this probably being caused by the tension of the wire being too great on hauling in, and could easily be avoided.

The screw of the adjusting friction-wheel was worn out. But it was found that a few metres of wire could easily be hauled in without the use of this gear. The dynamometer soon got out of order and even after being repaired was not improved. It was found that this type of dynamometer was not proof against the shocks to which the ballast-scale was exposed with a pitching and heaving ship.

It is however of so little practical use that it can safely be dispensed with, the loading of the scale being a sufficient guide to find the average tension of the rope, always bearing in mind that the scale itself weighed 18 kilogrammes and when in equilibrium the strain on the rope is about half the combined weight of the scale and weights together.

During the course of one year, from March 7<sup>th</sup> 1899 to March 1<sup>st</sup> 1900, when the soundings above referred to, were made with this machine, the following list of accidents occurred.

Date and depth.	Accidents.	Cause and remarks.
1899. March 22. 122 fathoms.	Pianowire breaks. One cocklead, one waterbottle, one reversing thermometer lost with 87 metres of wire.	The lead struck the ground, wire broken because of heave of the ship.
1899. March 23. 408 fathoms.	Stray line of TANNER's line broken. SIGSBEE lead and reversing thermometer lost.	Stray line of six strands, probably defective, broke off sharp. Since then only double twisted flag-chord was used.
1899. April 3. 809 fathoms.	Pianowire broke; lost: lead of 25 kilogram with reversing thermometer.	Wire run out of top-pulley, kinked and broke.
1899. August 9. 459 fathoms.	Waterbottle and reversing thermometer lost.	Indicator still registered 50 metres when suddenly the stray line ran into the reel, and the line broke. Pointer of indicator had probably slipped. Outside attendant's warning to stop when he saw the weight of the stray line, was not heard on account of the noise of the machine.
1899. Sept. 16. 1111 fathoms.	Wire broke off at thermometer. Lead and thermometer lost.	Wire was found to be wrenched off, probably due to the revolving, caused by the fixed screw of the reversing frame.
1899. Dec. 3. 2753 fathoms.	The outside attendant's finger caught in the pulley and was cut off.	One of the component strands, which was found to be snapped, caught the hand of the assistant who did not let go his rag in time. Before the machine could be stopped his finger got cut off.
1900. Febr. 10. 1442 fathoms.	2600 metres of wire, one cocklead and one reversing thermometer lost.	By the rolling of the ship the wire got slack and got caught in the toothwheel of the winch. As the brake did not act promptly, the winding drum continued to revolve. The wire being damaged got broken by the next heave of the ship.

This last accident showed the desirability of having the wire rove through an oblong eye fixed to the machine just above the point where the wire reaches the winding-drum.

For even should a momentary slack occur in the wire, this would prevent the wire leaping off the drum.

## THE LUCAS DEEP SEA SOUNDING-MACHINE SMALL SIZE AS USED ON BOARD H. M. SIBOGA.

### *Description of the machine.*

(Fig. 11.)

This consists of two vertical cast-iron frames *BB* connected together and carrying between them the winding-drum *A*, capable of holding 400 fathoms of 0.9 mm. steel wire.

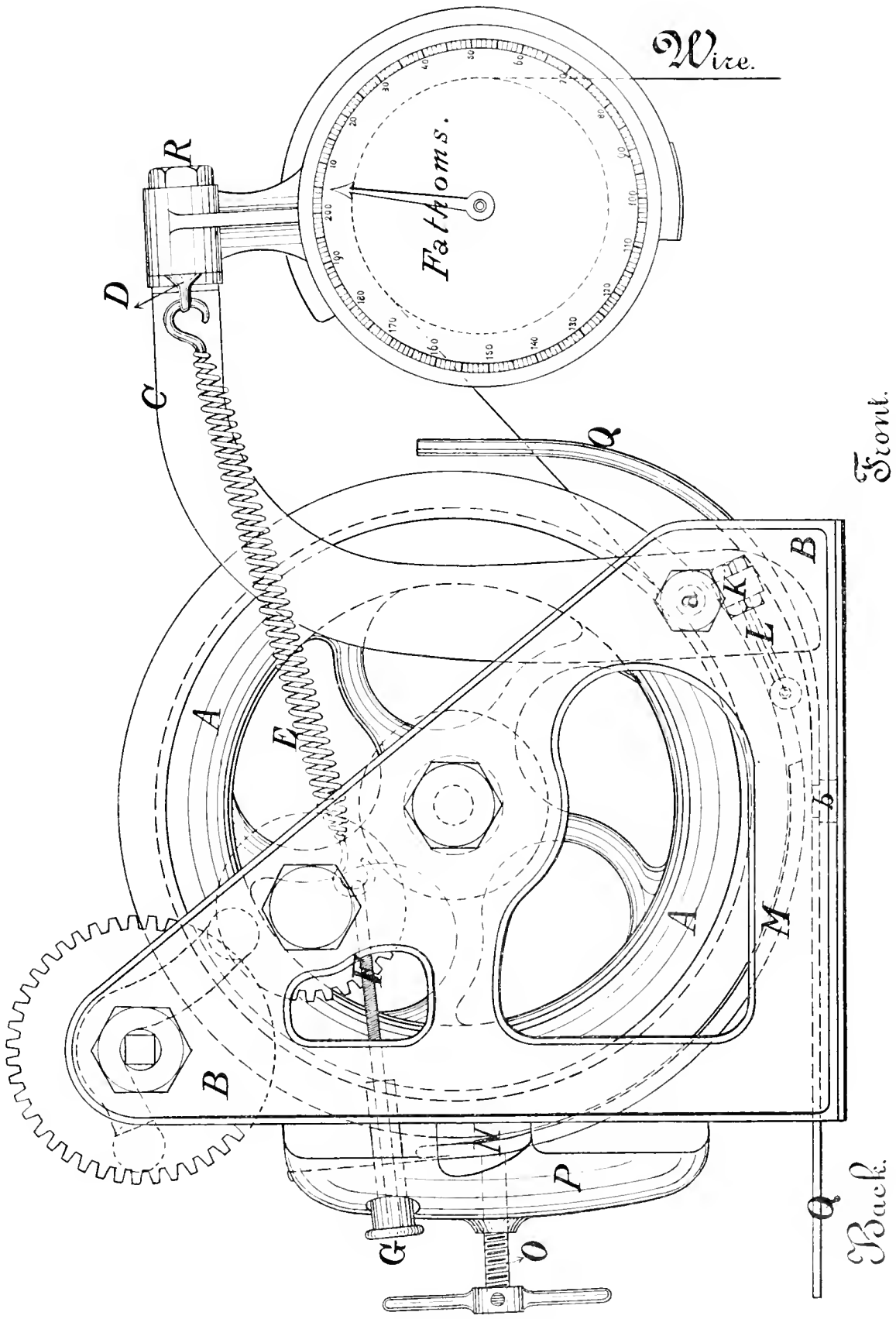

Fig. II.

From the upper arms of a curved double lever  $C$  is suspended the pulley over which the sounding wire passes; this pulley is hinged horizontally on the pin  $R$  to allow it to follow the even varying angle of the wire, and serving at the same time as revolution-counter indicating the depth. The curved lever  $C$  works on two fulcrum-pins  $a a$  fixed in the sideframes, the lower arms of the levers are connected together by a crosspiece  $K$  carrying the adjustable bolts  $L$ , forming the one end of the brake belt  $M$ , the upper end of this brake belt is attached to the sliding brake-block  $N$ , this too is adjustable by means of the screw with cross-handles  $O$  working in plate  $P$ .

The upper ends of the lever  $C$  are connected by the crosspiece  $D$ , each end of which carries a spiral spring  $E$ , the tension is adjustable by the milled nuts  $GG$ .

The wire on its way between the pulley and the drum passes through a forked guide  $Q$ , swivelling on the pin  $b$ , this guide is worked by hand and enables the wire to be wound fair on the drum.

For winding in the wire a hand-gear with double handles is fitted, this is uncoupled when running the line out.

#### *Manipulation and working of the Machine.*

For sounding with this machine one man only is required. The winding in needs one or two assistants.

The lead is attached to the wire by means of a stray line of cord weighted at the top, as is the case in all sounding machines in which steel wire is used.

When the lead hangs free, the spiral springs  $E$  are extended and the lever  $C$  falls forward until the lower end strikes against the stops, placed on the inside of the sideframes for this purpose. As the lever falls forward, the brake belt is slackened off the wiredrum, except at the point of the sliding block  $N$ . This is screwed tight when the machine is out of use. The hand-gear being then also uncoupled. When preparing to sound, the sliding block is gradually unscrewed until the lead begins to drop, the rate of descent being regulated by hand.

As soon as the lead reaches the bottom, the strain on the rope decreases, allowing the spiral springs to contract and raise the lever  $C$ , tighten the brake and automatically stopping the drum. This being a sign that the lead has reached the bottom.

The sliding-block is then screwed up tight and the amount of wire out read off. The hand-gear is coupled in, the sliding-block released and the line wound in.

One of the assistants works the guide  $Q$  and sees that the line is wound evenly on the drum. When the stray line reaches the drum, the sliding-block is tightened, the hand-gear uncoupled and the lead drawn in.

#### *Remarks on the sounding with the Lucas-machine.*

The line must not be allowed to run out too fast, two fathoms per second is a good average speed.

If not carefully regulated, the drum unwinds at such a rate that the wire, especially with a rolling or pitching ship, loses too much of its tension, this allows the lever to rise and tighten the brake, causing a sudden decrease in the veering of the rope, consequently the strain on the rope increases and the brake is slackened again. This goes on repeatedly causing the lever to rise and fall to no good.

The tension of the spiral springs and correct adjustment of the sliding-block is found by experience, taking in consideration the type of sounding lead in use and the amount of wire out.

The adjustment of the brake-belt can remain unaltered for a considerable time.

Any kind of lead can be used with this machine but as the hauling in is done by hand, it is desirable to have the lead not heavier than absolutely necessary.

On board of H. M. Siboga we always successfully used an ordinary lead weighing 12 kilogram, fitted with grease, occasionally also a light sliplead. As the indicator registers the amount of rope out, the line should hang as nearly as possible vertical during the sounding.

With regard to the measures to be taken and the manoeuvring of the ship, the same remarks apply as those given for the Le Blanc-machine, also to the keeping in repair of the machine and wire. A loose wooden cover over the machine was found to be a great help to its preservation.

#### *Observations on the machine.*

The small size Lucas-machine gave every satisfaction.

It was used both on board the ship and in the boats and was fixed to the end of a board which facilitated its being placed in position where ever it was wanted. Its usual place was on the starboardside of the bridge, the board being fastened to the railing and the machine projecting as far overboard as would insure a vertical drop, well free of the ship.

A sounding of a hundred fathoms took about five minutes: 50 seconds for dropping the lead and 4 minutes for hauling it in.

No other accidents occurred than once when the lead jammed and bent the plate-iron lever, breaking the line. This mishap can be avoided by making the stray line no stronger than is necessary to carry the lead safely and raise it from the ground.

It is also advisable to provide the handles on the shaft with setscrews as it happened that one handle was lost by dropping off.

This machine can be highly recommended for hydrographic work as the sounding, both at moderate and at great depth, is done more vertically and more accurately than with an ordinary sounding line.

For ordinary navigation it is inferior to the Thompson-machine as it requires the ship to be almost at rest during sounding.

For the vessels in the hydrographic service the small size Lucas machine is the proper instrument for all soundings over 20 fathoms, for shallower depths the ordinary hand lead is to be preferred as it can be thrown forward and does not require the same reduction in speed as the automatic machine. If the depth is approximately known and not very great,

soundings can be made with the Lucas-machine at a moderate speed of ship by placing it in a high position.

The lead is then carried well forward before it is dropped.

For regular and frequent use in tolerably great depths a position on the stern rail is desirable, because as soon as the lead is off the ground speed can be got up and course steered, thus saving a considerable time.

Carrying the lead forward must however then be dispensed with, unless the machine stands far enough overboard so that there is no danger of the wire fouling the propellor.

*For arrangement of appliances on board H. M. Siboga see Plate I—III.*



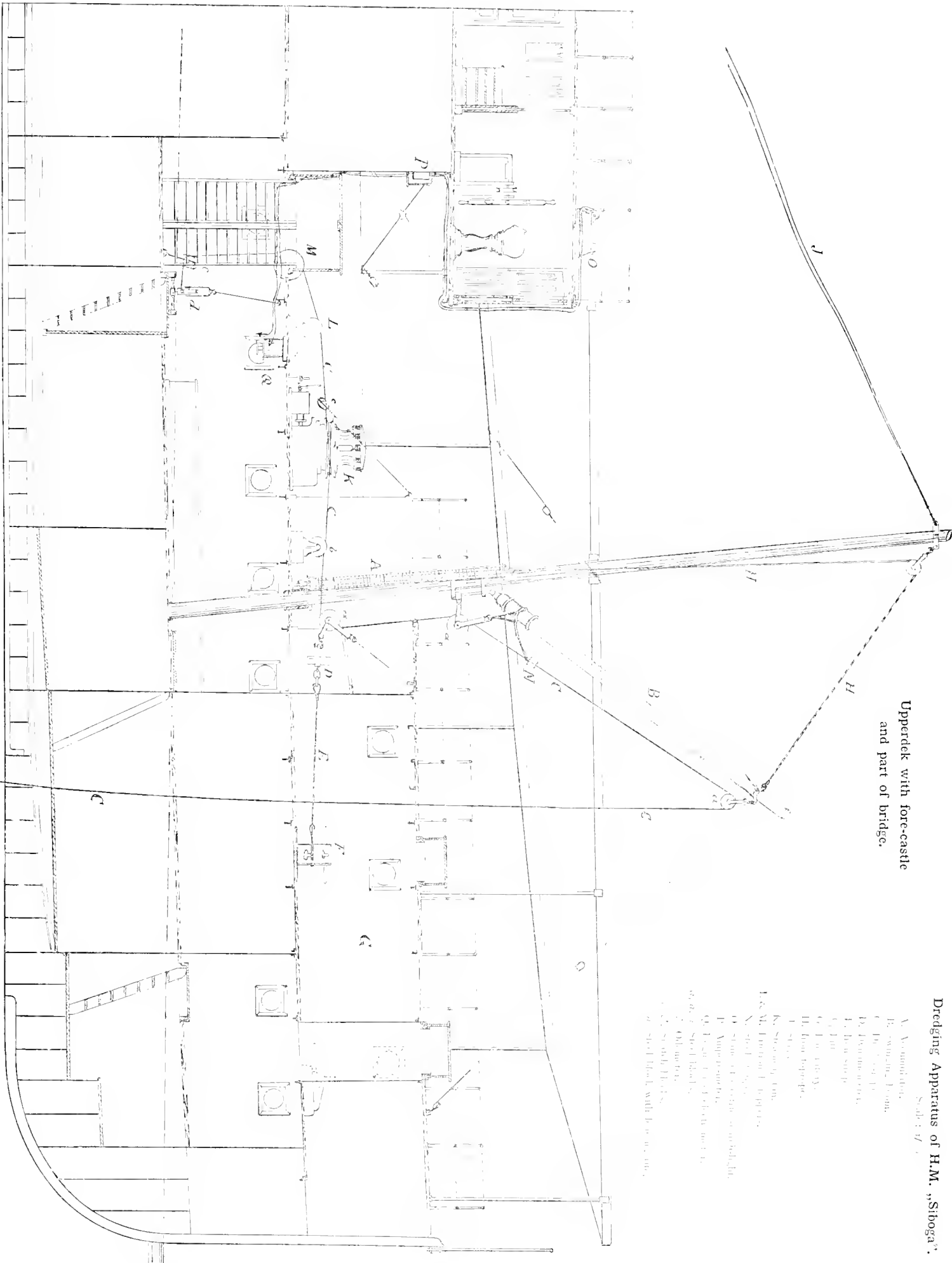

Upperdeck with fore-castle and part of bridge.

Dredging Apparatus of H.M. "Siboga".

Scale 1/10.

- A. Axle-moulding.
- B. Swimming beam.
- C. Dredging pulley.
- D. Flange-moulding.
- E. Flange support.
- F. Flange.
- G. Flange.
- H. Iron rope.
- I. Roller.
- J. Roller.
- K. Support of beam.
- L, M, N. Flange of rollers.
- O. Support of beam.
- P. Support of beam.
- Q. Support of beam.
- R. Support of beam.
- s. Old mortar.
- t. Support of beam.
- u. Steel head with bearing.



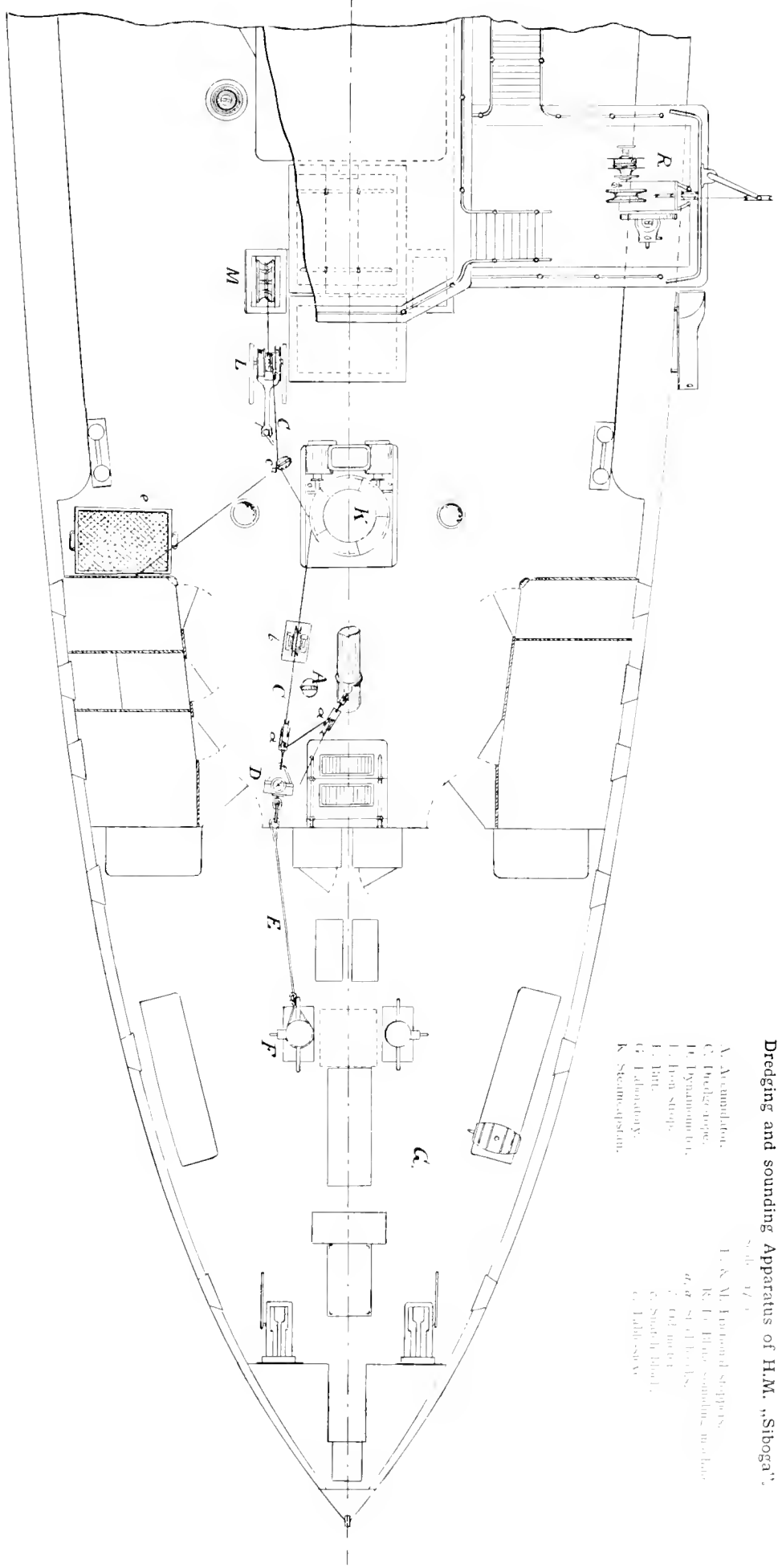

**Dredging and sounding Apparatus of H.M. „Siboga”.**

- A. Accumulation.
- C. Treadle-ropes.
- D. Dynamometer.
- E. Iron-ropes.
- F. Bait.
- G. Laboratory.
- K. Steam-system.
- L. Accumulation.
- M. Treadle-ropes.
- N. Dynamometer.
- O. Iron-ropes.
- P. Bait.
- Q. Laboratory.
- R. Treadle-ropes.
- S. Dynamometer.
- T. Iron-ropes.
- U. Bait.
- V. Laboratory.
- W. Steam-system.

Scale 1/100



Dredging and sounding Apparatus of H.M. „Siboga”.

Scale: 1/30

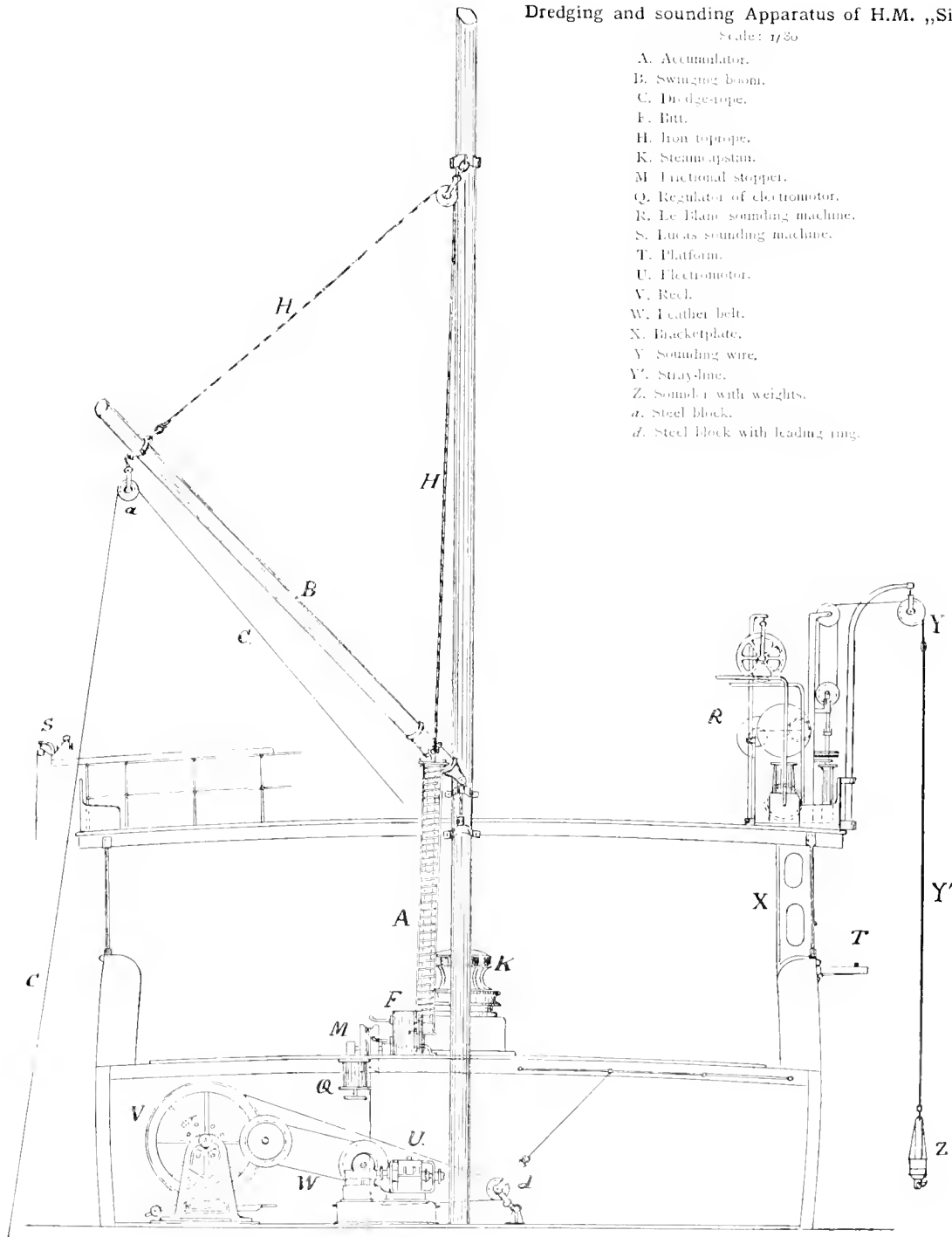

- A. Accumulator.
- B. Swinging boom.
- C. Dredge-rope.
- F. Butt.
- H. Iron top-rope.
- K. Steam stop-valve.
- M. Frictional stopper.
- Q. Regulator of electromotor.
- R. Le Blanc sounding machine.
- S. Lucas sounding machine.
- T. Platform.
- U. Electromotor.
- V. Reel.
- W. Leather belt.
- X. Bracketplate.
- Y. Sounding wire.
- Y'. Stray-line.
- Z. Sounding weight.
- a. Steel block.
- d. Steel block with leading ring.





RÉSULTATS DES EXPLORATIONS  
ZOOLOGIQUES, BOTANIQUES, OCÉANOGRAPHIQUES ET GÉOLOGIQUES

ENTREPRISES AUX  
INDES NÉERLANDAISES ORIENTALES en 1899—1900,  
à bord du **SIBOGA**

SOUS LE COMMANDEMENT DE  
**G. F. TYDEMAN**

PUBLIÉS PAR  
**MAX WEBER**  
Chef de l'expédition.

- \*I. Introduction et description de l'expédition, Max Weber.
- \*II. Le bateau et son équipement scientifique, G. F. Tydeman.
- III. Résultats hydrographiques, G. F. Tydeman.
- IV. Foraminifera.
- V. Radiolaria.
- VI. Porifera, G. C. J. Vosmaer et J. H. Vernhout.
- VII. Hydropolypi, Ch. Julin.
- VIII. Hydrocorallinae, S. J. Hickson.
- IX. Siphonophora, M<sup>l</sup>les Lens et van Riemsdijk.
- X. Hydromedusae, O. Maas.
- XI. Scyphomedusae, O. Maas.
- XII. Ctenophora, M<sup>l</sup>le F. Moser.
- XIII. Gorgonidae, Alcyonidae, J. Versluys.
- XIV. Pennatulidae, S. J. Hickson.
- XV. Aetiniaria, P. Mc Murrie.
- XVI. Madreporaria, A. Alcock et L. Döderlein.
- XVII. Antipatharia, P. N. van Kampen.
- XVIII. Turbellaria, L. von Graff et R. R. von Stummer.
- XIX. Cestodes, J. W. Spengel.
- XX. Nematodes, A. A. W. Hubrecht.
- XXI. Chaetognatha, G. H. Fowler.
- XXII. Nemertini, A. A. W. Hubrecht.
- XXIII. Myzostomidae, R. R. von Stummer.
- XXIVa. Polychaeta errantia, R. Horst.
- XXIVb. Polychaeta sedentaria, M. Caullery et F. Mesnil.
- XXV. Gephyrea, C. Ph. Sluiter.
- XXVI. Enteropneusta, J. W. Spengel.
- XXVII. Brachiopoda, J. F. van Bemmelen.
- XXVIII. Bryozoa, S. F. Harmer.
- XXIX. Copepoda, A. Scott.
- XXX. Ostracoda, G. W. Müller.
- XXXI. Cirripedia, P. P. C. Hoek.
- XXXIIa. Isopoda, H. J. Hansen.
- XXXIIb. Epicaridae, J. Bonnier.
- XXXIII. Amphipoda, J. Bonnier.
- XXXIV. Caprellidae, P. Mayer.
- XXXV. Stomatopoda, H. J. Hansen.
- XXXVI. Leptostraca, H. J. Hansen.
- XXXVII. Schizopoda, H. J. Hansen.
- XXXVIII. Sergestidae, H. J. Hansen.
- XXXIX. Decapoda, J. G. de Man.
- XL. Pantopoda, J. C. C. Loman.
- XLI. Halobatidae, J. Th. Oudemans.
- XLII. Crinoidea, L. Döderlein p. p.
- XLIII. Echinoidea, J. C. H. de Meyere.
- \*XLIV. Holothurioida, C. Ph. Sluiter.
- XLV. Ophiuroidea, R. Köhler.
- XLVI. Asteroidea, L. Döderlein.
- XLVII. Solenogastres, H. F. Nierstrasz.
- XLVIII. Chitonidae, H. F. Nierstrasz.
- XLIX. Prosobranchia, M. M. Schepman.  
L. Opisthobranchia, R. Bergh.
- LI. Heteropoda, J. J. Tesch.
- LII. Pteropoda, J. J. Tesch.
- LIII. Lamellibranchiata, P. Pelseneer et Ph. Dautzenberg.
- LIV. Scaphopoda.
- LV. Cephalopoda, L. Joubin.
- LVI. Tunicata, C. Ph. Sluiter.
- LVII. Pisces, Max Weber.
- LVIII. Cetacea, Max Weber.
- LIX. Liste des algues, M<sup>l</sup>le A. Weber.
- \*LX. Halimeda, M<sup>l</sup>le E. S. Barton.
- LXI. Melobesiacae, M<sup>l</sup>le A. Weber et M. Foslie.
- LXII. Dinoflagellata, Coccosphaeridae, J. P. Lohs.
- LXIII. Diatomaceae, J. P. Lohs.
- LXIV. Deposita marina, O. B. Böggild.
- LXV. Résultats géologiques, A. Wichmann.

# Siboga-Expeditie

DESCRIPTION OF THE SHIP

AND

APPLIANCES USED FOR SCIENTIFIC EXPLORATION

BY

G. F. TYDEMAN

With 3 plates and illustrations

Monographie II of:

**UITKOMSTEN OP ZOOLOGISCH,  
BOTANISCH, OCEANOGRAPHISCH EN GEOLOGISCH GEBIED**

verzameld in Nederlandsch Oost-Indië 1899—1900

aan boord H. M. Siboga onder commando van  
Luitenant ter zee 1<sup>e</sup> kl. G. F. TYDEMAN

UITGEGEVEN DOOR

**Dr. MAX WEBER**

Prof. in Amsterdam, Leider der Expeditie

(met medewerking van de Maatschappij ter bevordering van het Natuurkundig  
onderzoek der Nederlandsche Koloniën)

BOEKHANDEL EN DRUKKERIJ

**E. J. BRILL**  
LEIDEN



Voor de uitgave van de resultaten der Siboga-Expeditie hebben  
bijdragen beschikbaar gesteld:

De Maatschappij ter bevordering van het Natuurkundig Onderzoek der Nederlandsche  
Koloniën.

Het Ministerie van Koloniën.

Het Ministerie van Binnenlandsche Zaken.

Het Koninklijk Zoologisch Genootschap »Natura Artis Magistra'' te Amsterdam.

De »Oostersche Handel en Reederij'' te Amsterdam.

De Heer B. H. DE WAAL, Consul-Generaal der Nederlanden te Kaapstad.





## CONDITIONS GÉNÉRALES DE VENTE.

---

- 1°. L'ouvrage du „Siboga” se composera d'une série de monographies.
- 2°. Ces monographies paraîtront au fur et à mesure qu'elles seront prêtes.
- 3°. Le prix de chaque monographie sera différent, mais nous avons adopté comme base générale du prix de vente: pour une feuille d'impression sans fig. flor. 0.15; pour une feuille avec fig. flor. 0.20 à 0.25; pour une planche noire flor. 0.25; pour une planche coloriée flor. 0.40.
- 4°. Il y aura deux modes de souscription:
  - a. La souscription à l'ouvrage complet.
  - b. La souscription à des monographies séparées en nombre restreint.Dans ce dernier cas, le prix des monographies sera majoré de 25 %.
- 5°. L'ouvrage sera réuni en volumes avec titres et index. Les souscripteurs à l'ouvrage complet recevront ces titres et index, au fur et à mesure que chaque volume sera complet.

---

### Déjà paru:

- |                                                                                                                                                        |        |
|--------------------------------------------------------------------------------------------------------------------------------------------------------|--------|
| 1 <sup>e</sup> Livraison. (Monographie XLIV) <b>C. Ph. Sluiter</b> . Die Holothurien der Siboga-Expedition. Mit 10 Taf. . . . .                        | f 7.50 |
| <i>Pour les souscripteurs à l'ouvrage complet.</i>                                                                                                     | „ 6.—  |
| 2 <sup>e</sup> Livraison. (Monographie LX) <b>E. S. Barton</b> . The genus Halimeda. With 4 plates. . . . .                                            | f 2.40 |
| <i>Pour les souscripteurs à l'ouvrage complet.</i>                                                                                                     | „ 1.80 |
| 3 <sup>e</sup> Livraison. (Monographie I) <b>Max Weber</b> , Introduction et description de l'expédition. Avec Liste des Stations et 2 Cartes. . . . . | f 9.—  |
| <i>Pour les souscripteurs à l'ouvrage complet.</i>                                                                                                     | „ 6.75 |







