

U.S. Army  
Coast. Eng. Res. C

MR 76-4  
(AD-A022 337)

# Simplified Design Methods of Treated Timber Structures for Shore, Beach, and Marina Construction

by  
James Ayers and Ralph Stokes

MISCELLANEOUS REPORT NO. 76-4  
MARCH 1976

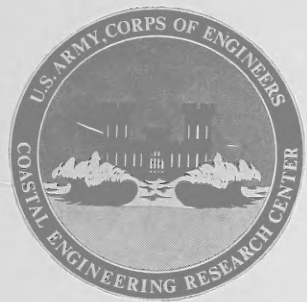

Approved for public release;  
distribution unlimited.

Prepared for  
U.S. ARMY, CORPS OF ENGINEERS  
COASTAL ENGINEERING  
RESEARCH CENTER

Kingman Building  
Fort Belvoir, Va. 22060

TC  
203  
0581  
MR  
76-4

Reprint or republication of any of this material shall give appropriate credit to the U.S. Army Coastal Engineering Research Center.

Limited free distribution within the United States of single copies of this publication has been made by this Center. Additional copies are available from:

*National Technical Information Service  
ATTN: Operations Division  
5285 Port Royal Road  
Springfield, Virginia 22151*

Contents of this report are not to be used for advertising, publication, or promotional purposes. Citation of trade names does not constitute an official endorsement or approval of the use of such commercial products.

The findings in this report are not to be construed as an official Department of the Army position unless so designated by other authorized documents.



REPORT DOCUMENTATION PAGE		READ INSTRUCTIONS BEFORE COMPLETING FORM
1. REPORT NUMBER  MR 76-4	2. GOVT ACCESSION NO.	3. RECIPIENT'S CATALOG NUMBER
4. TITLE (and Subtitle)  SIMPLIFIED DESIGN METHODS OF TREATED TIMBER STRUCTURES FOR SHORE, BEACH, AND MARINA CONSTRUCTION	5. TYPE OF REPORT & PERIOD COVERED	
	6. PERFORMING ORG. REPORT NUMBER	
7. AUTHOR(s)  James Ayers Ralph Stokes	8. CONTRACT OR GRANT NUMBER(s)	
9. PERFORMING ORGANIZATION NAME AND ADDRESS  American Wood Preservers Institute 1651 Old Meadow Road McLean, Virginia 22101	10. PROGRAM ELEMENT, PROJECT, TASK AREA & WORK UNIT NUMBERS  F31234	
11. CONTROLLING OFFICE NAME AND ADDRESS  Department of the Army Coastal Engineering Research Center (CEREN-DE) Kingman Building, Fort Belvoir, Virginia 22060	12. REPORT DATE  March 1976	
	13. NUMBER OF PAGES  39	
14. MONITORING AGENCY NAME & ADDRESS (if different from Controlling Office)	15. SECURITY CLASS. (of this report)  UNCLASSIFIED	
	15a. DECLASSIFICATION/DOWNGRADING SCHEDULE	
16. DISTRIBUTION STATEMENT (of this Report)  Approved for public release; distribution unlimited.		
17. DISTRIBUTION STATEMENT (of the abstract entered in Block 20, if different from Report)		
18. SUPPLEMENTARY NOTES		
19. KEY WORDS (Continue on reverse side if necessary and identify by block number)		
Design methods	Shore protection structures	Piers
Marine construction	Bulkheads	Seawalls
Pressure-treated timber	Groins	
20. ABSTRACT (Continue on reverse side if necessary and identify by block number)  Pressure-treated timber has wide application in the waterfront and shore protection structures that are built in marina developments and other shore and beach locations bordering on bays, lakes, and river resorts. Because of its strength, durability, and economy, pressure-treated timber is the principal construction material for bulkheads, seawalls, piers, and groins at locations with mild exposure and shallow-to-intermediate water depths.		

## PREFACE

This report is published to provide coastal engineers with simplified technical guidelines on the proper use of treated timber in coastal structures. This study is published under the coastal construction research program of the U.S. Army Coastal Engineering Research Center (CERC).

The report was originally prepared in October 1969 by James Ayers and Ralph Stokes for the American Wood Preservers Institute (AWPI), McLean, Virginia. CERC was instrumental in identifying the need for this data and encouraged the AWPI to develop the study. In 1970, AWPI published a condensed version of this report in their Technical Guidelines Series titled, *Bulkheads: Design and Construction*. CERC is publishing the complete manuscript to achieve a wider distribution of these data which are not readily available in other engineering publications. Permission by the AWPI to publish this report is greatly appreciated.

This report is published, with only minor editing, as prepared by the authors; results and conclusions are those of the authors and are not necessarily accepted by CERC or the Corps of Engineers.

Comments on this publication are invited.

Approved for publication in accordance with Public Law 166, 79th Congress, approved 31 July 1945, as supplemented by Public Law 172, 88th Congress, approved 7 November 1963.

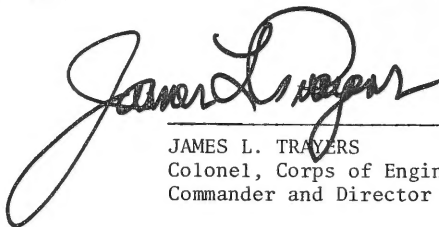

---

JAMES L. TRAVERS  
Colonel, Corps of Engineers  
Commander and Director

## CONTENTS

	Page
I INTRODUCTION . . . . .	5
II TIMBER BULKHEADS . . . . .	5
1. Typical Timber Bulkheads . . . . .	9
2. Construction Procedures . . . . .	9
3. Design Steps . . . . .	11
III VERTICAL-FACED SEAWALLS OF TREATED TIMBER . . . . .	26
1. Design of Timber Seawalls . . . . .	26
2. Treated Timber in Concrete Seawalls . . . . .	28
IV DESIGN OF GROINS . . . . .	28
1. Types . . . . .	28
2. Location on Shore . . . . .	30
3. Dimensions . . . . .	30
4. Profile . . . . .	30
5. Spacing . . . . .	30
6. Advantages of Treated Timber . . . . .	31
7. Acting Forces . . . . .	31
8. Sizes of Structural Members . . . . .	31
9. Typical Timber Groin . . . . .	32
V FINGER PIER AND WAVE BARRIER FOR MARINA . . . . .	32
1. Pier Dimensions . . . . .	36
2. Design of Pier Framing, Supports, and Bracing . . . . .	36
LITERATURE CITED . . . . .	38
APPENDIX . . . . .	39

### TABLES

1 Unit weights of soils and coefficients of earth pressure . . . . .	13
2 Schedule for estimation of wave action . . . . .	19

### FIGURES

1 Bulkhead design, zero water depth . . . . .	6
2 Bulkhead design, 4-foot water depth . . . . .	7
3 Bulkhead design, 8-foot water depth . . . . .	8
4 Basic vertical dimensions of a bulkhead or seawall . . . . .	12

CONTENTS

FIGURES—Continued

	Page
5 Pressure diagram for bulkhead . . . . .	14
6 Lateral pressure diagrams . . . . .	15
7 Types of sheet piling . . . . .	18
8 Seawall for moderate wave exposure . . . . .	27
9 Seawall for intermediate wave exposure . . . . .	29
10 Timber groin . . . . .	33
11 General plan of marina pier . . . . .	34
12 Sections of typical marina pier . . . . .	35
13 Floating marina . . . . .	37

SIMPLIFIED DESIGN METHODS OF  
TREATED TIMBER STRUCTURES  
FOR  
SHORE, BEACH, AND MARINA CONSTRUCTION

*by*

*James Ayers and Ralph Stokes*

I. INTRODUCTION

Pressure-treated timber has wide application in the waterfront and shore protection structures that are built in marina developments and other shore and beach locations bordering on bays, lakes, and river resorts. Because of its strength, durability, and economy, pressure-treated timber is the principal construction material for bulkheads, seawalls, piers, and groins at locations with mild exposure and shallow-to-intermediate water depths.

II. TIMBER BULKHEADS

Bulkheads are boundary structures that separate land from water (Figures 1, 2, and 3). They are built along shorelines and waterways and on the periphery of harbor developments, serving to retain earth usually by means of a vertical wall. The wall is made of timber sheet piles driven into the ground for support against outward movement. The tops of the sheet piles bear against a horizontal distributing member, or wale, connected to an anchor system by steel tie rods.

There are two general types of anchor systems. The passive-resistance type (Figures 1 and 2) uses buried timbers located well below the finished ground surface at some distance behind the sheet piles. Earth pressure prevents displacement of this type of anchorage. The A-frame anchor (Figure 2) derives its resistance from the structural action of round timber piles arranged in groups. Some piles are vertical; others are battered (inclined). Suitable connections between piles enable the A-frame to resist lateral displacement by developing thrust in the batter piles and uplift in the vertical piles. Although either type of anchorage system may be used alone or in combination for any type of bulkhead, the A-frame is generally used for the higher bulkheads because it develops a greater resistance to the pull of the tie rod.

Seawalls are protective retaining structures that occupy an advanced position along a shoreline as barriers to wave attack. Seawalls are not clearly distinguishable from bulkheads. A vertical-faced retaining structure that is subject to direct wave attack of some degree of intensity is classified as a seawall, whereas a similar vertical-faced structure alongside a relatively quiet harbor waterfront, with little or very mild wave action, is classified as a bulkhead.

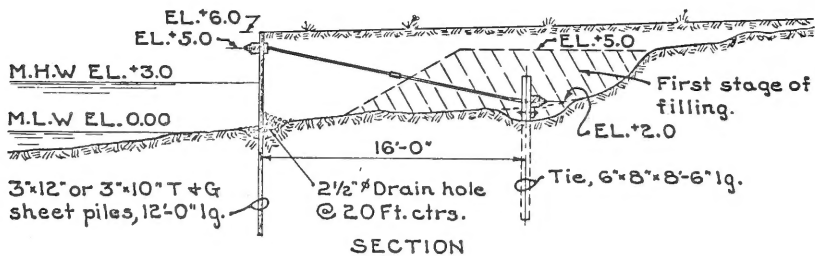
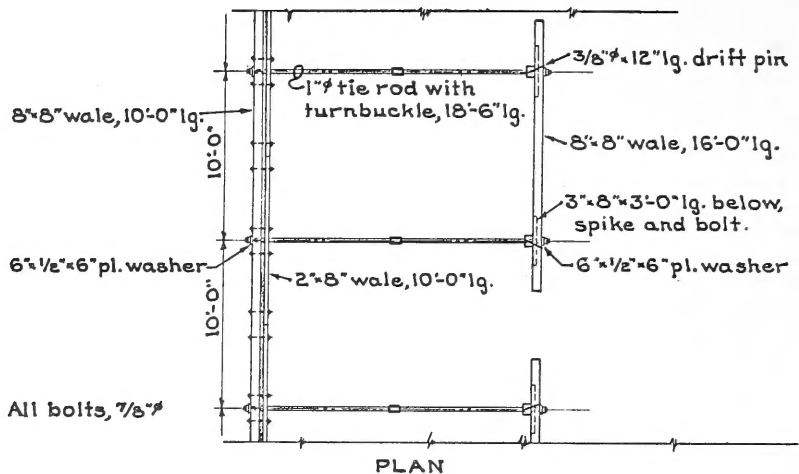
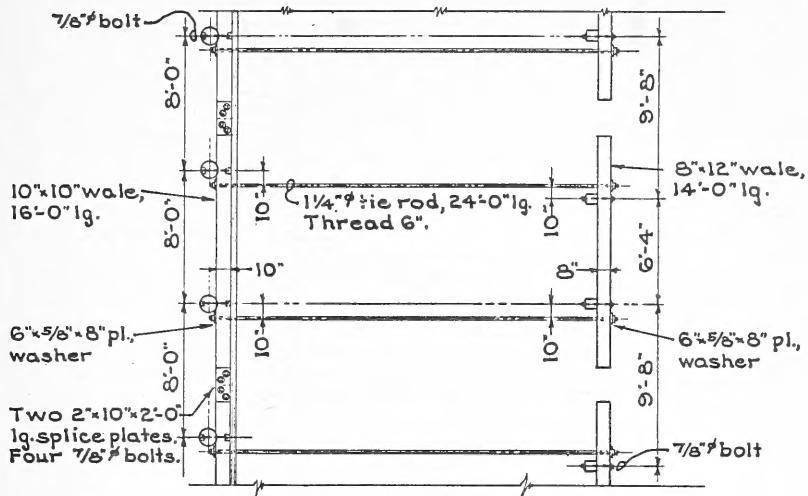
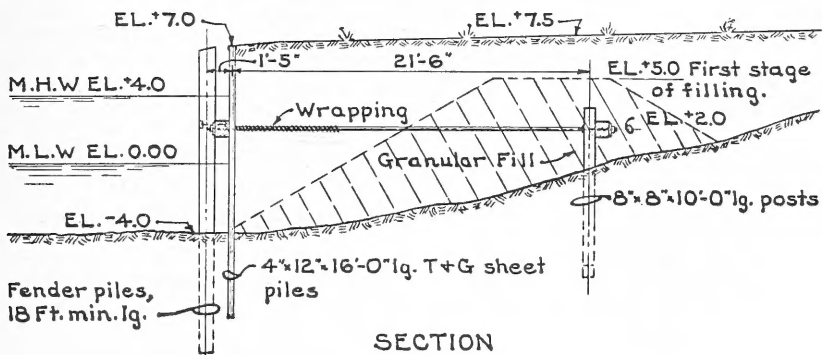

Figure 1. Bulkhead design, zero water depth.





PLAN



SECTION

Figure 2. Bulkhead design, 4-foot water depth.



## 1. Typical Timber Bulkheads.

Figure 1 shows a conservatively designed, low bulkhead for installation where the existing grade along the sheet piles is somewhat higher than the low water level. Figure 2 shows an intermediate bulkhead suitable for retaining fill at the site of a marina or for providing a finished waterfront in a housing development. If these bulkheads are located farther inshore, or if the outside water level variations are less than shown in the figures, the heights of bulkheads and lengths of sheet piles may be reduced.

The anchorage systems (Figures 1 and 2) depend upon the passive resistance of a mound of earth immediately around the anchor post and wales. The theoretical mound required to develop this passive resistance is shown by a dotted line. If backfill is placed directly against the sheet-pile bulkhead before this mound of earth is placed around the anchor system, the resulting forces may displace the bulkhead or even push it over, resulting in a costly and disastrous failure. After the mound is placed over the anchorage system, backfill can be deposited against the sheet piles by a dragline, truck dumping, hydraulic pipelines, or other suitable methods.

Figure 3 shows a bulkhead suitable for the deepwater parts of marinas, or for locations where the existing water depths are 6 to 8 feet and extensive landfills are desirable. The anchorage system (Figure 3) is a self-supporting A-frame that does not depend on passive earth resistance. This anchor system is particularly adaptable to filling by the hydraulic method because the backfill can be raised behind the sheet piles without regard for the placement of backfill at the anchorage location.

To install the A-frame anchorage, a pile-driving rig is required to drive the piles to specified bearing capacity. At locations with less water level variation than the 4 feet shown, the height of finished grade may be lowered proportionally. For an increase in water level variation, a similar increase in height of finished grade can be made with a corresponding reduction in water depth. The 5-foot vertical distance from finished grade to tie rod level should be maintained.

## 2. Construction Procedures.

The proper sequence for bulkhead construction is:

- (a) Drive all round timber piles, both vertical and battered; set or drive all posts.
- (b) Using bolts, attach the horizontal wales for the sheet piles and the anchorage system.
- (c) Drive sheet piling.

- (d) Complete all bolted connections and install tie rods.
- (e) Place the backfill; where passive resistance anchorage systems are used, be certain to place fill over the anchors before backfilling behind the sheet-pile wall.

Establish accurate survey lines as a control for the construction of waterfront and shore protection structures, and anchorage systems. Exercise care in locating positions of round piles and posts that support horizontal timbers that will be used as driving guides for sheet piles. In all cases, use a driving guide for sheet piles, preferably the permanent horizontal wale that is attached to the vertical round piling or posts (Figures 1, 2, and 3).

It is particularly important to drive the first few sheet piles accurately vertical in all directions. The wall must be plumb and the sheet piles must not be inclined within the plane of the wall. One of the common problems facing piling contractors is "creep," the tendency for successive sheet piles to lean more and more in the direction of construction of the wall. The wall can be perfectly plumb, yet piles can lean; this error in alinement tends to accumulate and, if left uncorrected, can create considerable difficulties in driving successive piles. Chellis (1961) has a discussion of this situation and how to correct it. As sheet-pile driving proceeds, place the tongue of each new sheet in the forward position and the groove in tight contact with the tongue of the sheet previously driven. Keep the joints between piles as tight as practicable. Remember that the maximum allowable opening at joints is one-half inch for splined and Wakefield piling, and one-fourth inch for tongue and groove piling. If wider joints appear after the sheet piles have been spiked to the outer wale, cover with treated timber lath to prevent the backfill material from gradually filtering through the cracks and being lost.

Wherever passive-resistance anchorage systems are used the anchorage must be well covered with a mound of earth before backfill material is deposited to any appreciable depth against the piling. Otherwise, the pressures generated by the backfill may disrupt the sheet piling and the anchorage system.

Use a predominately granular material for backfill adjacent to the sheet piling and over the anchorage system. Shoreward of the anchorage, a poorer quality filling material may be used unless it is objectionable from the standpoint of foundation support for shore structures.

If the hydraulic method is used for backfilling, provide sufficient drainage to permit rapid escape of water at the ends of the construction area, both to prevent formation of pools and to maintain as low a free water level in the backfill as possible. Although the bulkhead is designed to hold earth, it may not be designed to resist water pressures that can be generated during hydraulic filling.

One method of facilitating drainage is to provide openings through the sheet piling above the level of the outside wale. Space these openings at intervals of about 60 feet to supplement the escape of drainage water. The final 3 feet of backfill adjacent to the sheet piles should be put into place by earthmoving equipment to avoid hydraulic pressures at the upper parts of the bulkhead. The hydraulic discharge line should be parallel to the bulkhead alinement, not directed at it, and should be located at least 100 feet behind the bulkhead sheet piling.

a. Site Conditions. At a construction site, the natural conditions that exert the most influence on the design of any waterfront structure are water level variation, wave action, and type of soil. Ice conditions are a special consideration for locations subject to the effects of solid ice sheets, floating icefields, or large icepacks.

b. Removal of Poor Quality Soils. Often the natural soil is capable of providing the necessary resistance for the lower ends of the sheet piling in seawalls, bulkheads, and groins. However, if the bottom soil is soft silt, mud, or soft clay, it should be removed and replaced with granular materials.

In most cases, earthfill is required above the existing ground line for some distance shoreward from the face of the sheet piling. The filling material for a sufficient width to encompass the anchor system should be predominantly granular in nature, even though it may be necessary to transport it from a considerable distance.

### 3. Design Steps.

Several steps are required in the design of an anchored bulkhead as follows:

(a) Determine the following basic information (Figure 4):

- Water depth required (by owner).
- Water level variation in front of sheet piling.
- Ground water level behind bulkhead at time of low water level in front.
- Level of finished grade behind bulkhead.
- Types of soil available for backfill and for resisting movement of lower ends of sheet piling; unit weights of moist and submerged soils (Table 1).
- Amount of vertical surcharge loads (if any) anticipated on ground behind bulkhead (determined from proposed use of site).

(b) Prepare earth-pressure diagrams for inner and outer faces of sheet piling to obtain resultant pressure diagram (Figures 5 and 6).

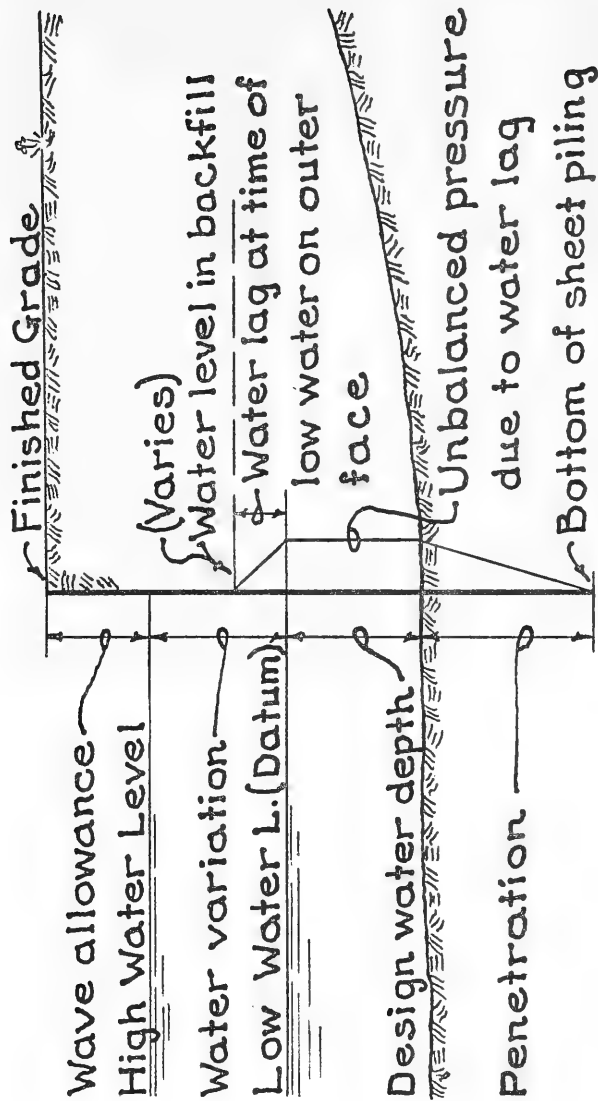

Figure 4. Basic vertical dimensions of a bulkhead or seawall.

Table 1. Unit weights of soils and coefficients of earth pressure.

Soil Type	Unit weight of soil (pounds per cubic foot)		Active Earth Pressure			Passive Earth Pressure					
	moist submerged		Coefficient, $K_A$ soils in backfill place	Angles of friction (degree)	Coefficient, $K_A$ soils in place	Angles of friction (degree)	Coefficient, $K_A$ soils in place	Angles of friction (degree)			
	Min.	Max.							Min.	Max.	
Clean sand:											
Dense	110	140		65	78	0.20	38	20	9.0	38	25
Medium	110	130		60	68	0.25	34	17	7.0	34	23
Loose	90	125		56	63	0.35	30	15	5.0	30	20
Silty sand:											
Dense	110	150		70	88					7.0	
Medium	95	130		60	68					5.0	
Loose	80	125		50	63	0.50				3.0	

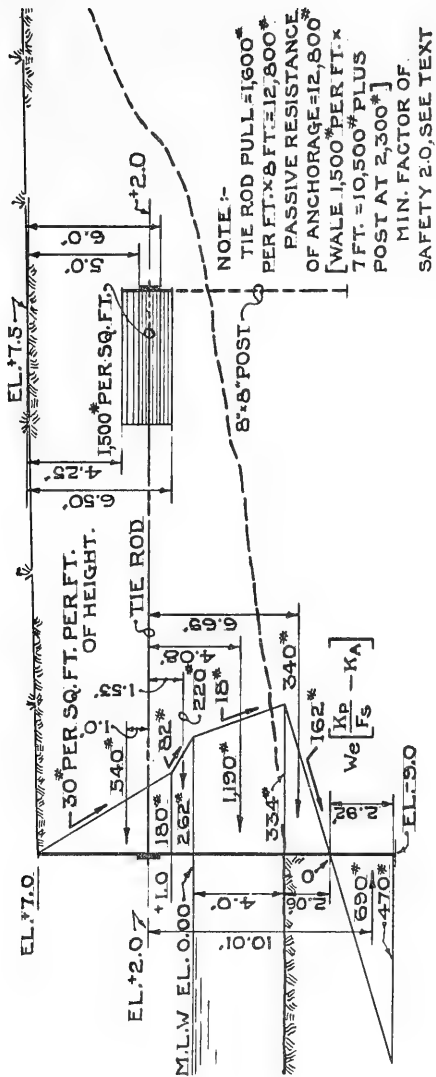

Figure 5. Pressure diagram for bulkhead.



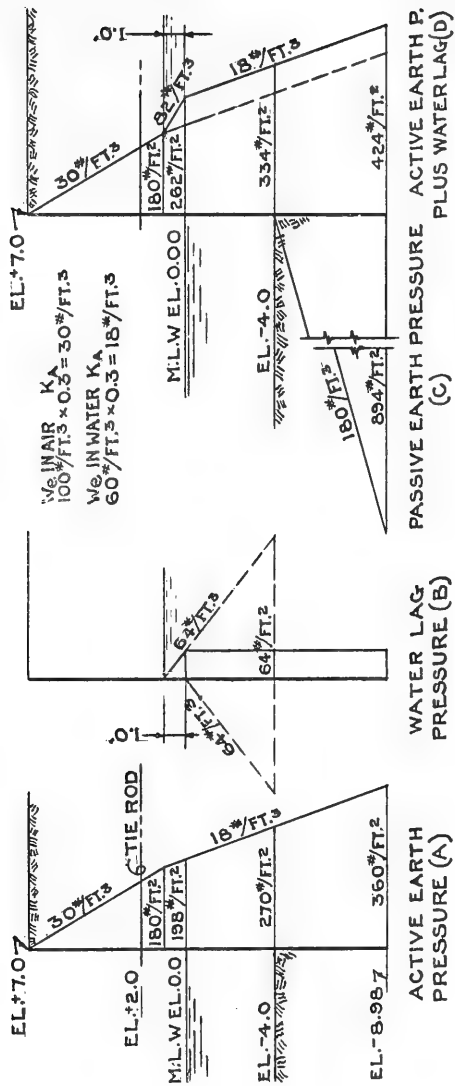

Figure 6. Lateral pressure diagrams.

(c) Determine depth of sheet pile penetration and pull in the tie rods.

(d) Compute bending moment in sheet piling.

(e) Determine required thickness of sheet piling.

(f) Determine size and spacing of tie rods.

(g) Determine bending moment and required size of wales.

(h) Design anchorage to resist for tie-rod pull.

a. Basic Information.

(1) Water Depth Required. The depth of water against the face of a timber bulkhead must be determined before the bulkhead can be designed. If the bulkhead is simply a "retaining wall" for shore protection of a building site, the depth of water may be whatever naturally results when the bulkhead is constructed along the desired shoreline. Elsewhere, the depth of water may depend upon the types of boats that may be brought adjacent to the bulkhead (e.g., in a marina). In the latter case, the property owner or the developer of the marina may establish minimum requirements for water depth. Some dredging may be required to achieve these depths, although, generally, the least costly solution is to place the bulkhead farther from shore in deeper water.

(2) Water Level Variation. At coastal locations, the water level variation on the exposed face of the sheet piling may be obtained from tide tables published by the National Oceanic and Atmospheric Administration (NOAA), National Ocean Survey (NOS). At inland locations adjacent to lakes and rivers, seasonal records of high and low water levels may be used. These latter data are available from Corps of Engineers Divisions or Districts, State or local conservation agencies, city or county engineers, and building officials.

The "design value" used for the high water level requires some judgment. This value need not be the highest water level ever recorded in the vicinity, but should be a reasonably high value that, statistically, is expected to occur within the design life of the structure.

(3) Depth of Scour. The construction of a bulkhead may deflect wave energy in such a way that it erodes the bottom material adjacent to the sheet piling. This is most likely to occur in shallow depths, especially if mean low water (MLW) is less than 2 feet. It is advisable to assume that the energy deflection, occurring at the time of intermediate and higher tide stages, will erode the bottom material to a depth of 2 or 3 feet below MLW. Accordingly, when lacking more definitive data, assume a minimum low water depth of 2 to 3 feet. This will result in a requirement for slightly longer sheet piling, but will

prevent the failure that can occur if the bottom material is eroded to the extent that the sheet piling may be shoved out of place.

(4) Water Level in the Backfill. The ground water level in the backfill will rise and fall as the tide rises and falls. This is caused mostly by natural percolation of water through the soil, behind the lower parts of the bulkhead wall, rather than by water passing through cracks in the bulkhead. Because the soil slows down the flow of water somewhat, the ground water level behind the bulkhead is seldom the same as the free water level on the seaward side. As the tide rises, the ground water level rises, but at a slower rate. Similarly, as the tide recedes, the ground water level falls, also at a slower rate. The distance between these two water levels is called the *water lag* (Figure 4).

When the free water is higher than the ground water there is no particular design problem. The water pressure is resisted by the soil backfill. But when the ground water level is higher than the free water, there is an outward pressure that is resisted only by the wall and its anchorage system.

The net effect of the ground water pressure is similar to that of the backfill against the bulkhead. The outward pressure of both water and soil must be considered in the design of a bulkhead wall.

To determine the ground water level, dig a hole behind the sheet piles of any nearby bulkhead. Water will rise and fall to measurable levels. If no bulkheads exist in the vicinity, use a minimum value of 1 foot, or a maximum of one-half the tidal variation, for the water lag.

As the water level recedes during ebbtide, the water in the ground behind the sheeting will escape through any openings left in the wall, carrying away the finer particles of the soil backfill. During numerous tidal interchanges, large quantities of backfill can escape in this manner, unless tight joints are provided between sheet piles. Joints used to minimize losses are shown in Figure 7.

(5) Finished Elevations. The criteria used to determine the basic vertical dimensions of a bulkhead are shown in Figure 4. The finished elevation of the bulkhead and backfill was listed by making an allowance for wave action above the high water level.

Wave height is a function of wind velocity and duration, of expanse of water (*fetch*) over which the wind blows, and of water depth. Methods for estimating wave height and period under various site conditions are described in the Shore Protection Manual (U.S. Army, Corps of Engineers, Coastal Engineering Research Center, 1973).

In protected areas, where treated timber bulkheads have their best application, the length of fetch and water depth are limited. In most cases, the expected wave heights range from 1 to 2 feet.

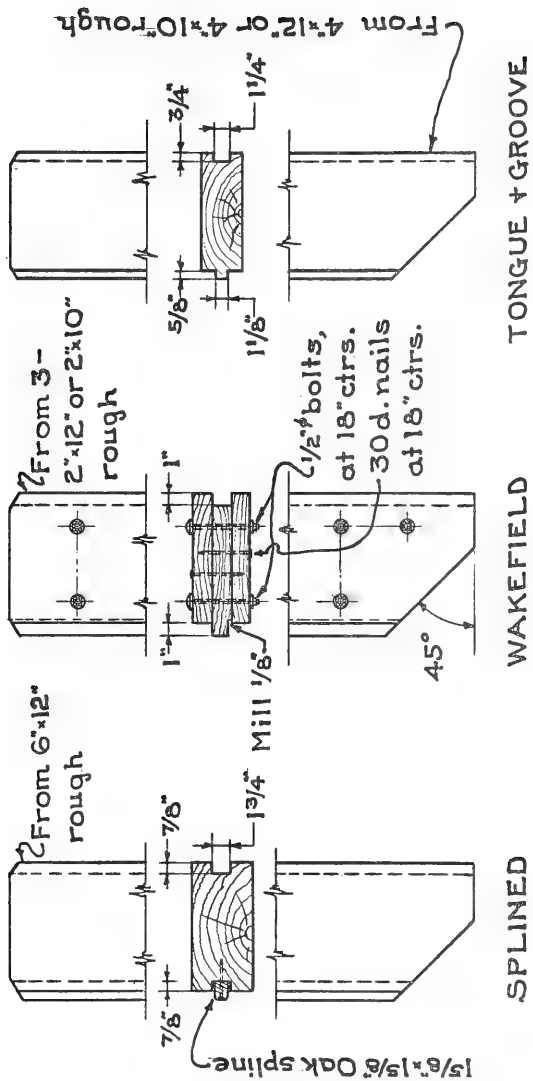

Figure 7. Types of sheet piling.

Use the following schedule (Table 2) to estimate wave action, where a more precise calculation is not required:

Table 2. Schedule for estimation of wave action.

Wave height crest to trough (feet)	Minimum height of bulkhead above high water level, as allowance for wave action (feet)
1 to 2	3
2 to 3	4

By observing the heights of existing structures in a particular locality, experience can often be used as a guide in arriving at the elevation of the finished grade.

(6) Available Soil Materials. Granular materials, such as sand and gravel, are preferred for backfill behind bulkheads and for base materials into which sheet piles are driven. Granular materials have several characteristics that make them desirable. The active pressures they exert on bulkheads are considerably less than those exerted by silts and clays or even by sands that are "contaminated" with silt or clay. Granular materials can develop a higher passive resistance, permitting the use of shorter sheet piles.

It is often preferable to bring granular materials to the construction site by truck or other conveyance rather than to backfill with silt or clay. In the final analysis, a judgment is required. A designer must determine whether it is more economical or more desirable to increase the thicknesses of materials in the bulkhead rather than to transport granular materials from far distances. Fortunately, granular materials are quite often readily available near bodies of water.

Granular material also promotes drainage behind the bulkhead and is less likely to be eroded away through minor fissures in the bulkhead as the water level rises and falls. The drainage is advantageous wherever the backfill is to be used for roadways, sidewalks, parks, yards, etc. Grass and plants will grow better in a soil that is moderately well drained; the granular material will not shrink and swell with alternate drying and wetting to the same degree that clay will. The backfilled area is not likely to resemble a marshy bog where drainage is provided through granular materials where lawns and other plantings are required, a relatively thin layer of top soil can be placed over the granular material.

Where the material at the shoreline is extremely poor quality, such as silt or clay, the passive resistance will be very low. This will require lengthening the sheet piling to obtain sufficient passive resistance to avert a failure. The greater length of sheet piling

induces a higher degree of bending in the piling, requiring a thicker piling than would otherwise be needed.

Under these circumstances, the designer should consider removing the poor soil and replacing it with a granular material, such as clean sand. The cost is often far less than that of providing thicker materials and more elaborate anchorage systems for the bulkhead.

(7) Lateral Earth Pressures. The sheet piles are driven into the ground to hold earth on one side of the wall at a higher level than on the other. The pressure exerted against the sheet piles by the retained earth is called *active earth pressure*. The pressure exerted by the earth on the low side in resistance to lateral movement of the sheet piling is called *passive earth pressure*. Because cohesive soils can resist far higher forces than they can create, the allowable passive pressure is always higher than the active pressure, occasionally nearly 10 times as much.

The magnitude and distribution of active pressure against a sheet-pile wall depends on a number of factors. These factors include the physical properties of the retained earth, the friction between the earth and the sheet-pile wall, the amount of deflection of the wall, and the flexibility of the sheet piles. Similar factors influence the magnitude and distribution of the passive earth pressure. For a discussion of the behavior of sheet-pile walls and the influence of various factors on the active and passive earth pressures, see Terzaghi (1954).

Customarily, the lateral earth pressures are proportional to the vertical pressure at any given level. If the symbol,  $P_v$ , designates the vertical pressure at any given level (weight of overlying soil), the lateral pressures are expressed as  $K_A P_v$  for active pressure and  $K_p P_v$  for passive. The symbols,  $K_A$  and  $K_p$ , are known as coefficients of earth pressure. In determining the vertical pressure  $P_v$  at any level in the soil for bulkhead design, the unit weight is that of moist earth above, and that of submerged earth below, the free water surface.

Sands are classified as dense, medium, or loose, to approximately describe the density, and as clean or silty to indicate the absence or presence of fine materials. These physical properties influence both the unit weights of the material and the earth pressure coefficients. Some physical properties for clean and silty sand are shown in Table 1 (Terzaghi, 1954).

For designing timber sheet-pile walls backfilled with predominantly granular materials and driven into natural undisturbed deposits, the following average values may be used for the unit weights of sand and for the earth pressure coefficients:

Unit weight of moist sand - - - - 100 pounds per cubic foot (pcf)

Unit weight of submerged sand - - - - 60 pcf.

$$K_A = 0.3$$

$$K_p = 5.0$$

For sandfills,  $K_p = 3.0$

b. Preparation of Earth Pressure Diagrams. Figure 5 shows a typical combined lateral pressure diagram for the bulkhead illustrated in Figure 2. Granular materials are assumed throughout, with the material below the outside bottom assumed as undisturbed soil. The combined lateral pressure diagram is obtained from the diagrams on Figure 6, showing the separate effects of active earth pressure, water lag, and passive earth pressure. The active earth pressure increases at a rate of  $K_A W_e$ , where  $K_A$  is taken as 0.3 and  $W_e$  is the effective unit weight of earth.  $W_e$  is taken as 100 pcf above the free water surface within the backfill and as 60 pcf below the free water surface. Hence, the active earth pressure increases at a rate of 30 pcf above the free water surface and at 18 pcf for the submerged earth. The available passive earth pressure increases at a rate of  $K_p W_e$  but, to allow for a factor of safety ( $F_s$ ) against the outward movement of the lower ends of the sheet piles, the rate of increase in the passive pressure is taken as  $K_p W_e / F_s$ . The factor of safety against the outward movement of the sheet piles should be in the range of 1.5 to 2.0. Hence, if  $F_s$  is taken as 1.67 and  $K_p$  is 5.0, the rate of increase for the passive pressure, including allowance for the factor of safety is:

$$\frac{5.0}{1.67} \times 60 \text{ pcf (submerged earth)} = 180 \text{ pcf.}$$

The free water surface behind the sheet piling for the diagrams on Figure 6 is taken as 1 foot above the outside water level, which for analysis is taken at MLW because the maximum outward forces occur at low water level. The unbalanced water pressure due to this 1-foot water lag augments the outward pressures of the earth.

Assuming that seawater weighs 64 pcf, the water lag pressure has a constant value of 64 pounds per square foot (psf) from MLW level to the level of the outside bottom at elevation minus 4 feet (-4). Although the water lag pressure probably decreases from its value of 64 psf at the level of the outside bottom (-4) to a zero value at the bottom of the sheet piles, the assumption is often made that the water lag pressure continues at a constant value to the bottom of the sheet piles as shown by the solid line on Figure 6 (a and b). This assumption simplifies the computation process in arriving at the combined lateral pressure diagram, because the required depth of penetration for the sheet piling remains to be determined at the time that the construction of the pressure diagrams is in progress. Thus the slope, or rate of increase of the combined

pressure diagram below elevation 4 on Figure 5 is simply the difference between the value of 180 pcf for the passive pressure and 18 pcf for the active pressure, giving 162 pcf if the water lag pressure remains at its constant value of 64 pcf to the bottom of the sheet piles.

The diagram for active earth pressure plus water lag shown in Figure 6(d) is obtained by adding the pressure diagrams shown in Figure 6(a and b). The combined pressure diagram shown in Figure 5 results from adding the pressure diagrams shown on the two sides of the sheet piles in Figure 6(c and d).

c. Depth of Penetration. The sheet piling must extend below the outside bottom to a depth such that the total resultant force developed by the passive earth pressure will be of sufficient magnitude and so located that, together with the tie rod reaction, it will equalize the effects of the summation of outward loads produced by the combined active earth pressure and water lag pressure. This requirement is known as the equilibrium of moments condition about the tie rod reaction.

To determine the required depth of penetration, the forces for the several pressure areas behind the bulkhead, and the positions of their centers of gravity with respect to the tie rod level are determined in Figure 5. The moments of these forces about the tie rod level are computed as shown in the following tabulation:

Force (pounds)	Arm (feet)	Moment (pounds feet)
540	-1.0	-540
220	1.52	340
1,190	4.08	4,850
<u>340</u>	6.69	<u>2,280</u>
2,290		6,930

The location of the zero value (point "0", Figure 5) for the combined pressure diagram is at a distance below the outside bottom of:

$$\frac{334}{162} = 2.06 \text{ feet.}$$

The required penetration below point "0" is designated by the letter "d". Then the equilibrium of moments condition is expressed by the equation:

$$162 \frac{d^2}{2} \left( 8.06 + \frac{2}{3} d \right) = 6,930.$$

This equation is best solved by trial, where  $d = 2.92$  feet. The total depth of penetration below outside bottom is then  $2.06 + 2.92 = 4.98$  feet. The residual passive pressure intensity at the bottom of the sheet piles is computed as:



$$162 \times 2.92 = 470 \text{ psf.}$$

The area of the residual passive pressure triangle is:

$$470 \times 2.92 \times \frac{1}{2} = 690 \text{ pounds per lineal foot of wall:}$$

the tie rod reaction then becomes:

$$2,290 - 690 = 1,600 \text{ pounds per foot of wall.}$$

d. Design Step: Bending Moment in Sheet Piling. Maximum moment occurs at elevation of zero shear. Let "Z" = distance below MLW to plane of zero shear. Then in the case of Figure 5 Z is found as follows:

$$\text{Shear at MLW} = 1,600 - 540 - 200 = 840 \text{ pounds}$$

$$262Z + 18\frac{Z^2}{2} = 840 \text{ pounds where } Z = 2.92 \text{ feet}$$

$$262Z = 763 \qquad 18\frac{Z^2}{2} = 77$$

$$\frac{Z}{2} = 1.46 \qquad \frac{Z}{3} = 0.97$$

Moments of forces above plane of zero shear taken with respect to plane of zero shear are shown in the following tabulation:

<u>Force</u>	<u>Arm</u>	<u>Clockwise</u>	<u>Moment</u> <u>Counterclockwise</u>
1,600	4.92	7,870	-----
540	5.92	-----	3,200
220	3.39	-----	750
763	1.46	-----	1,110
77	0.97	-----	75
<hr/>			<hr/>
1,600			5,135

Bending moment in sheet piling per foot of wall length = 7,870 - 5,135 = 2,735 foot-pounds.

This is conventionally called the "free earth support" moment.

The free earth support moment may be reduced by a factor of 30 percent to allow for beneficial effects related to flexibility of sheet piling (Terzaghi, 1954).

Hence, design bending moment = 0.7 x 2,735 = 1,910 pounds per foot.

e. Design Step: Required Thickness of Sheet Piling.

Try 4- by 12-foot sheeting, actual thickness =  $3\frac{5}{8}$  inches;

$$\text{section modulus} = 12 \times \frac{3.625^2}{6} = 26.3 \text{ cubic inches};$$

$$\text{bending stress} = 1,910 \times \frac{12}{26.3} = \text{pounds per square inch (psi)}.$$

Try 3- by 12-foot sheeting, actual thickness =  $2\frac{5}{8}$  inches;

$$\text{section modulus} = 12 \times \frac{2.625^2}{6} = 13.8 \text{ cubic inches};$$

$$\text{bending stress} = \frac{1,910 \times 12}{13.8} = 1,660 \text{ psi}.$$

For sheet piling of common commercial grade, the 4-inch thickness should be used.

f. Design Step: Size and Spacing of Tie Rods. The size and spacing of tie rods must be compatible with the design of the wales and anchorage. A spacing of 8.0 feet will be selected.

$$\text{Tie rod pull} = 8 \times 1,600 = 12,800 \text{ pounds}.$$

For  $\frac{1}{4}$ -inch diameter tie rod, area at root of thread = 0.89 square inch;

$$\text{tensile stress} = \frac{12,900}{0.89} = 14,400 \text{ psi}.$$

This conservative unit stress is desirable to allow for effects of corrosion, surcharges, unequal yield of anchorages, and other variables.

g. Design Step: Bending Moment in Wales.

(1) Front Wale. Maximum moment over support

$$\frac{wl^2}{10} = 1,600 \times \frac{8^2}{10} = 10,200 \text{ pounds per foot}.$$

Deduct 2-inch width for tie rod hole.

For 12- by 10-foot wale, width =  $11.5 - 2 = 9.5$  depth = 9.5;

$$\text{section modulus} = 9.5 \times \frac{9.5^2}{6} = 143 \text{ cubic inches};$$

$$\text{bending stress} = \frac{10,200 \times 12}{143} = 850 \text{ psi}.$$

$$\text{horizontal shear} = \frac{3}{2} \times \frac{1,600 \times 4.0}{9.5 \times 9.5} = 107 \text{ psi}.$$

(2) Anchor Wale.

Maximum moment over support =

$$\frac{wa^2}{3} = 1,600 \times \frac{3^2}{2} = 7,200 \text{ pounds per foot.}$$

For a 12- by 10-foot wale with 2-inch width squared deducted for tie rod hole:

$$\text{Bending stress} = \frac{7,200 \times 12}{143} = 600 \text{ psi.}$$

$$\text{maximum moment at span} = \frac{wl^2}{8} - \frac{wa^2}{2} = 1,600 \times \frac{8^2}{3} - 7,200 = 5,600;$$

$$\text{section modulus (no hole)} = 11.5 \times \frac{9 \cdot 3}{6} = 173 \text{ cubic inches;}$$

$$\text{bending stress} = \frac{5,600 \times 12}{173} = 390 \text{ psi.}$$

h. Passive Resistance Anchorage. The anchorage for the bulkhead (Figure 3) relies on passive resistance. To locate this anchorage at a safe distance behind the bulkhead, a slope line is drawn from the bottom of the sheet piles to the finished grade at an angle  $\theta$  to the horizontal, where  $\theta$  is the angle of internal friction of the material. For the sand backfill assumed,  $\theta$  is taken as  $30^\circ$ . The upper edge of the anchorage should be located beneath or outside this slope line.

For a continuous anchorage (Figure 2) in which the height of bearing contact is only 1 foot, with center of bearing contact located 5.5 feet below the ground surface, the ultimate resistance is approximately equal to the bearing capacity of a continuous strip footing of a 1-foot width located at a depth of 5.5 feet (Terzaghi, 1943). The overburden pressure is 5.5 feet x 100 pounds per cubic foot which is 550 psf. Then by Terzaghi (1943):

Ultimate resistance =  $550 \cdot N'_q$  where  $N'_q$  is a bearing capacity factor to be taken from curve.  $N'_q$  is read as 7.0.

Ultimate resistance =  $550 \times 7.0 = 3,850$  psf.

For a 7-foot length of anchor wale to each tie rod, the ultimate resistance of the anchor wale is  $7 \times 1 \times 3,850 = 26,950$  pounds per tie rod. With a tie rod reaction of 1,600 pounds per foot, x 8 feet = 12,800 pounds, the factor of safety is  $\frac{26,950}{12,800} = 2.1$ . The resistance of the anchor post would increase this safety factor somewhat. A value of 2 is considered adequate. If an arbitrary limit of 3,000 pounds per square foot (1.5 tons) is assumed for the ultimate resistance (Figure 5), the total resistance including the anchor post will still provide a safety factor of 2.

i. Types of Treated Timber Sheet Piling. Sheet piles must have the necessary bending strength together with tight joints between adjacent sheets to prevent loss of sand. Sheet piles in material of a single thickness are desirable from the standpoint of structural strength in bending.

Figure 7 shows three types of sheet piling. If the single thickness strength required is 4 inches or less, tongue and groove joints are used. If the loads are sufficiently great as to require sheet-pile thicknesses of 6 inches or more, splined sheet piles are generally used for single thickness piling. In the event that timber in single thickness is not readily available, planks can be assembled into a composite section like the conventional Wakefield sheet pile. This pile has only 25 to 50 percent of the bending strength of a sheet pile in a single equivalent thickness, the amount of reduction depending on the size and spacing of the fastenings provided between the three pieces.

The lower ends of sheet piles should be cut at an angle as shown so that in the driving process each sheet pile is forced into close contact with the adjacent sheet previously driven.

### III. VERTICAL-FACED SEAWALLS OF TREATED TIMBER

Figure 8 shows a low height seawall for moderate wave action to afford protection to shore properties along a lake or bay front well removed from the attack of large waves. It is normally located so that the line of sheet piles intersects the ground surface somewhat above MLW level. The allowance of a 3- to 5-foot wall height above high water is adjusted to suit the height of wave action anticipated. The 7-foot minimum penetration of sheet piling is based on an allowance of a 2- to 3-foot depth of erosion below MLW in front of the structure. The length of the sheet piles is determined in accordance with the tidal variation and the distance allowed above high water to care for wave action.

The A-frame, which provides lateral support for the top of the sheet piling, is an efficient anchorage for a shoreline that has varying profiles through the beach with high banks adjacent to the bulkhead line at some locations and wide expanses of low ground at other locations. The A-frame spacing can be adjusted to suit the height of finished grade at the top of the sheet piles.

#### 1. Design of Timber Seawalls.

The vertical dimensions of seawalls are established in the same manner as for bulkheads. Due consideration must be given to the anticipated wave height in determining the wall height above high water level and the allowance for possible erosion of bottom materials in determining the length of sheet piles.

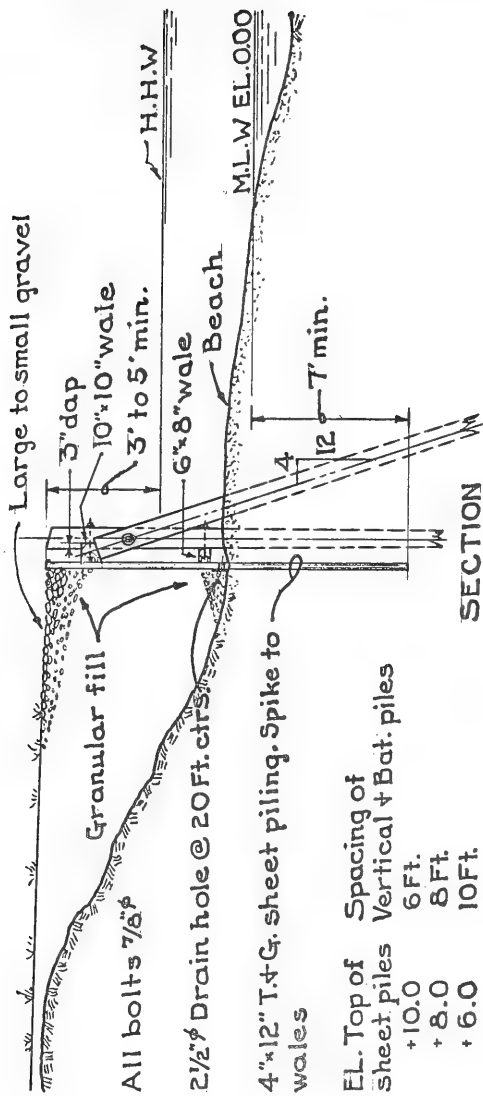

Figure 8. Seawall for moderate wave exposure.

As for bulkheads, the critical design condition is the tendency of the wall to move outward under the driving force of active earth pressure and unbalanced water pressure. The combined effects of these forces on seawalls are determined in the same way as for bulkheads. The forces due to oncoming wave action do not establish a critical design condition because any tendency for the wall to move shoreward is resisted by the force of passive earth pressure behind the sheet piles.

In locations subject to "rare" occasions of severe storms that raise the general water level by several feet (*storm surge*), it is not economical or practical to build timber seawalls sufficiently high to prevent wave overtopping. Consequently, it may be necessary to replace eroded backfill after the storm surge recedes.

In establishing the allowance for unbalanced water pressure, due consideration should be given to the past history of unusual water levels in a particular locality. For such abnormal conditions, a reduction in the usual safety factors can be tolerated.

## 2. Treated Timber in Concrete Seawalls.

Figure 9 is a seawall for intermediate exposure to wave action. This is a rigid-type cross section of reinforced concrete with stepped face. The structure is supported on round, treated timber piles and has a treated timber sheet-pile cutoff wall at the toe. This type of seawall has been used for exposure to 6-foot waves in storms along the gulf coast. The parapet wall may be added to prevent overtopping if scouring of the backfill material occurs as the result of unusually high wave action during storm surge. Adequate drainage is required behind the seawall for removal of surface water from rain and overtopping waves.

## IV. DESIGN OF GROINS

Groins are fingerlike barrier structures built perpendicular to the shoreline for extending and maintaining a protective beach.

At locations where the supply of sediments is not sufficiently large to fill a groin system without causing erosion of downdrift shores, artificial filling for the groin system is required so that the natural supply of sediments in transport may pass without reduction in volume. Lawsuits by owners of eroded property may be expected.

### 1. Types.

Groins are classified as impermeable, or permeable corresponding to their tightness as barriers to sediment movement. The current flow is completely obstructed by impermeable groins. Openings through permeable groins permit partial current flow and passage of a part of the suspended sediments past the barrier, often resulting in deposits on both sides of the groin. The sizes and spacings of the openings are sometimes varied to increase the flow progressively from shore to the seaward

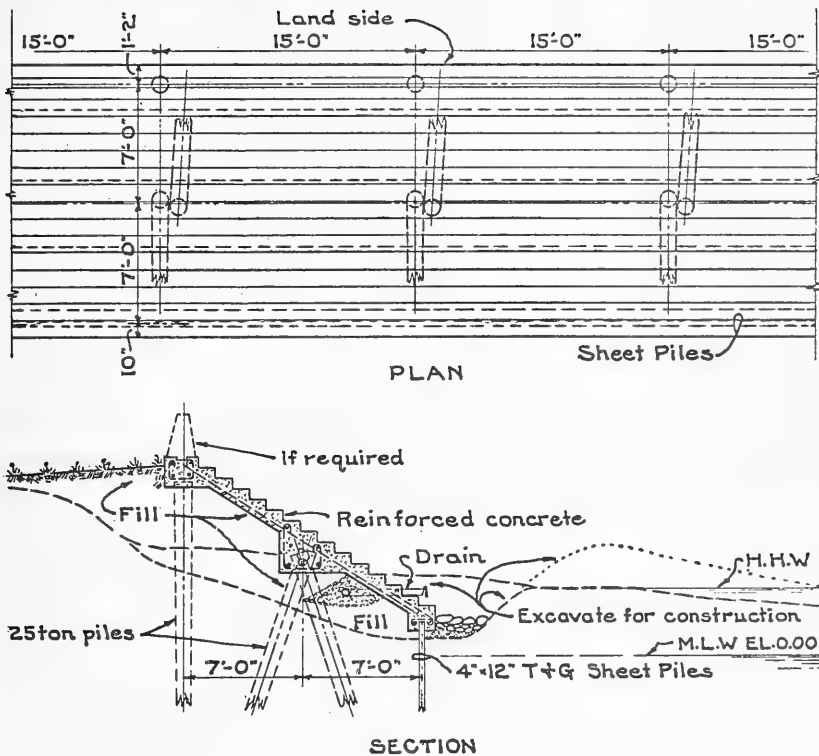

Figure 9. Seawall for intermediate wave exposure.

end. The degree of obstruction designed for the barrier must take into account the needs of shoreline segments for littoral materials down-drift from the particular area. In order to protect a long shoreline segment, groins are built in series as systems of barriers.

## 2. Location on Shore.

The suspended sediments travel along the foreshore in a band width extending from the breaker zone to the limit of wave uprush. Because the predominant part of sediments travel in the zone shoreward of the 6-foot-depth contour, groins are located at the inner margin of this band. Groins should be rooted in the shore landward of the crest of the beach berm sufficiently far to prevent flanking by littoral currents during storm wave attack at times of abnormally high water levels. Connection to a bulkhead or revetment is desirable. The outer ends are usually extended as far as the 6-foot-depth contour at low tide.

## 3. Dimensions.

The range in usual lengths extends from some minimum value less than 100 feet to a maximum of several hundred feet. Heights of groins vary with wave conditions and the degree of obstruction permissible, considering the material requirements of other shore segments downdrift of the particular groin system.

## 4. Profile.

Three sections are recognized along the length of a groin, namely the horizontal-shore section, the intermediate-sloped section and the outer-horizontal section.

The horizontal-shore section should be secured to a bulkhead or keyed into ground that is not disturbed by attack of severe storm waves. The shore section should extend, as a minimum height, to the level of normal wave uprush above high water. The maximum height required to retain all material reaching this section of the groin is the level of maximum wave uprush during all but the least frequent storms.

The top of the intermediate section matches the levels of the horizontal-shore section and the outer section. It is parallel to, and corresponds in length with the slope anticipated for the foreshore as a result of material retention by the structure. The outer section extends seaward from the intermediate-sloped section to such a length as is required to contain the intersection of the proposed beach slope updrift of the groin with the existing bottom. The top of the outer section is established as nearly as practicable at the MLW level, usually about 1 foot above it.

## 5. Spacing.

The fillet of sand trapped between groins tends to stabilize along



an alinement perpendicular to the predominant direction of wave attack as established by the direction of the orthogonals in a wave refraction diagram. The spacing between groins of a system should be correlated with the length of the groins so that the final stabilized alinement of the fillet between groins will provide the minimum width of beach desired at the updrift groin with a sufficient margin of safety to prevent flanking of the updrift groin. The distance between adjacent groins is in the range from one to three times the total groin length.

#### 6. Advantages of Treated Timber.

Marine-treated timber is a recognized construction material for building groins. It has the requisite strength to resist the applied forces at locations with mild to moderate wave action. There is the distinct advantage in withstanding abrasion from sand driven by the wind without ill effects. The marine treatment provides an effective protection for the timber against marine borers.

#### 7. Acting Forces.

The two significant forces to be considered in design of groins are earth pressure and wave action. The ordinary methods of computing earth pressure from granular materials are applicable. The magnitude of forces from earth pressure depend on the differential in level of the material on the two sides of the sheet piling. For an impermeable barrier wall, the maximum differential would occur at a time when the accretion fillet has about reached its stabilized depth updrift of the groin and the deposit of material on the downdrift side has only begun. The height differential in sand level on the two sides of a permeable groin would be considerably less than for an impermeable groin.

Three types of wave action are:

- (a) Reflected oscillatory motion (nonbreaking waves);
- (b) breaking waves;
- (c) broken waves (onrush).

For a discussion of methods for computing wave forces for the three types of wave action and illustrative examples, see U.S. Army, Corps of Engineers, Coastal Engineering Research Center (1973).

#### 8. Sizes of Structural Members.

The conventional method of arriving at the sizes of members is to follow successful examples from past engineering experience for similar environmental conditions. Whereas this method does not lend itself to close design tolerances, approximate computations can be made to investigate the strengths of the component parts shown for an existing design in relation to the environmental conditions expected at a particular location.

## 9. Typical Timber Groin.

Figure 10 illustrates a typical groin of the impermeable type using marine-treated timber throughout as the construction material. A vertical wall of timber sheet piling is framed into a system of horizontal timber wales and round vertical piles to form a tight barrier. The structure is supported laterally by the combined bending strength of the sheet piles and the round vertical piles, all of which derive their fixity from penetration into the earth bottom. The timber wales and the round piles serve to distribute the load from waves traveling along the wall, and thus limit the deflection of the local length loaded at a particular time and prevent opening of the joints between adjacent sheet piles.

The penetration of the round piles should satisfy two requirements, a minimum bearing capacity of 10 tons and a minimum penetration of 10 feet.

The sheet piles are made of two, 3-inch-thick timber staggered to produce a shiplap type of joint between sheets. Losses of material through joints in adjacent sheets are not so critical as in bulkheads. Some groins are deliberately made permeable. However, even if tight joints are desirable to prevent loss of material placed artificially to fill the groin, there is no paving to be undermined as is the case in many bulkheads. The two boards are spiked together for handling purposes and act only as individual planks in bending.

## V. FINGER PIER AND WAVE BARRIER FOR MARINA

In marinas where the tide range is 4 feet or less, the piers are supported on piling at a fixed elevation. However, for sites with higher tidal ranges, floating piers are used for the greater convenience afforded in gaining access to boats.

A conventional arrangement of pile-supported berthing facilities for small boats in a marina is illustrated in Figure 11. The berths for individual boats are laid out at right angles to, and on both sides of a finger pier. The pier may have a T-head at the outshore end where, as is often the case, the water depth is greater than that alongside the pier proper in order to accommodate the larger boats with deeper draft.

Figure 12 shows sections through a typical marina pier. Vertical timber planking is used to form a wall for the length of the T-head. This wall acts as a barrier to the passage of short surface waves moving toward shore. In some cases, the vertical planking is driven into the harbor bottom and is supported laterally at the top by the pier structure. If the wave action is only surface chop, the wall does not extend to the harbor bottom; the planks are entirely supported from the pier deck. Section B-B through the pier head indicates a round

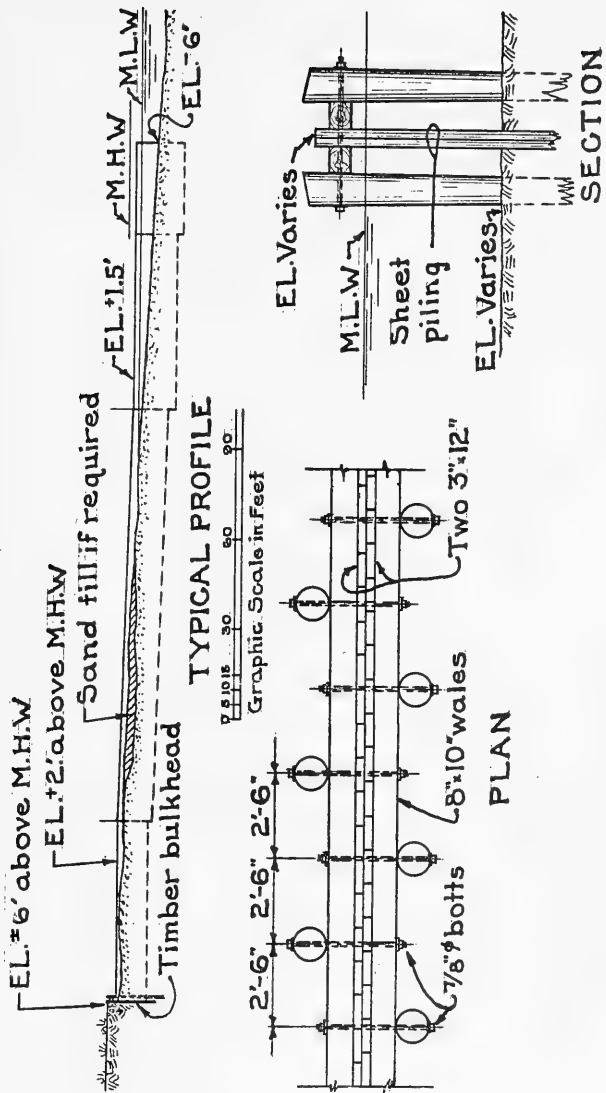

Figure 10. Timber groin.

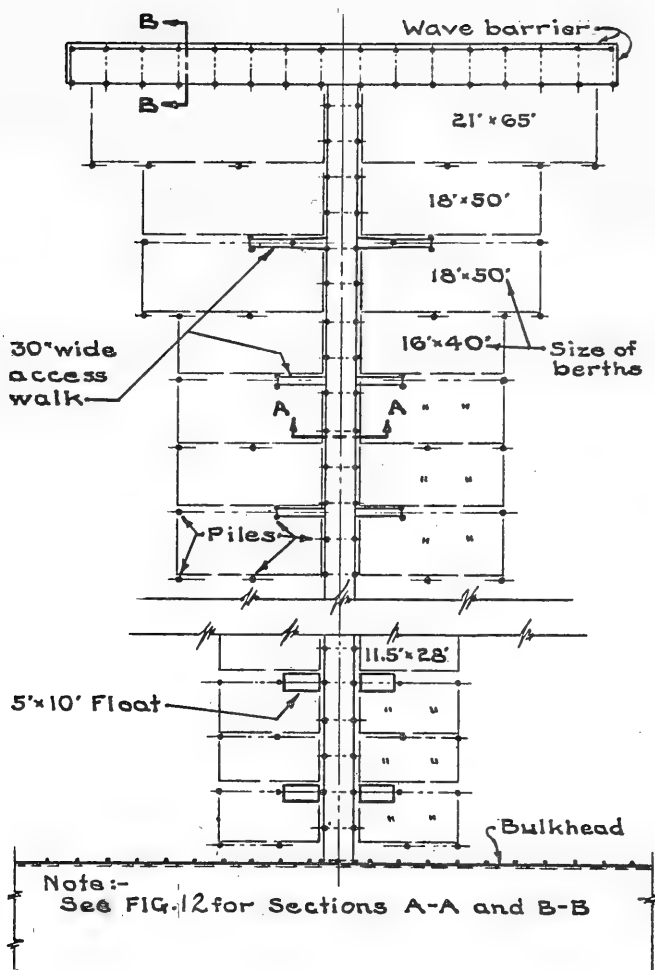

Figure 11. General plan of marina pier.

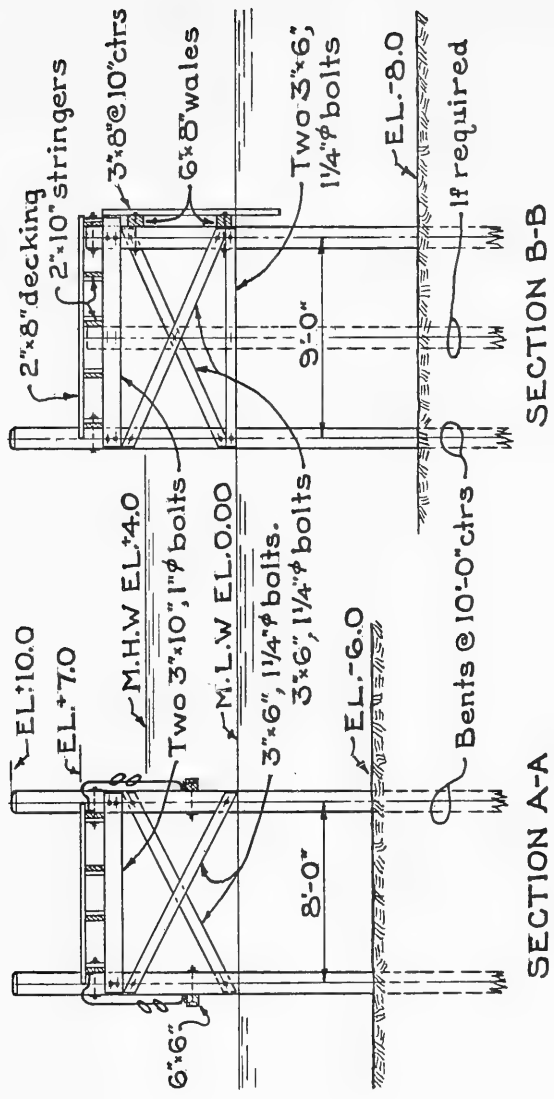

Figure 12. Sections of typical marina pier.

vertical pile (shown dotted on Figure 12). If wave action in the range of 2- to 3-foot heights occurs at the site, an additional pile in each bent to carry lateral loads should be provided. Plank barriers are to be considered only as supplements to any primary wave protection necessary for the marina site.

A layout plan for a floating marina with sections through the boat walkways is shown in Figure 13.

#### 1. Pier Dimensions.

The pier length is established in accordance with the number and widths of berths which are to be built alongside. The typical pier width is usually 8 or 9 feet wide. The pier deck is located a minimum of 3 feet above the mean high water level.

#### 2. Design of Pier Framing, Supports, and Bracing.

The framing arrangements, and the minimum thicknesses and sizes of members for deck planking and bracing timbers, are guided largely by conventional practice. The deck stringers are proportioned for a design uniform live load of 75 pounds per square foot of deck area.

The pile bents are spaced to suit the design of the deck stringers, with two piles in each bent. The specified deck loading usually does not determine the number and spacing of supporting piles, which are driven to a minimum bearing capacity of 10 tons, or minimum penetration of 10 feet.

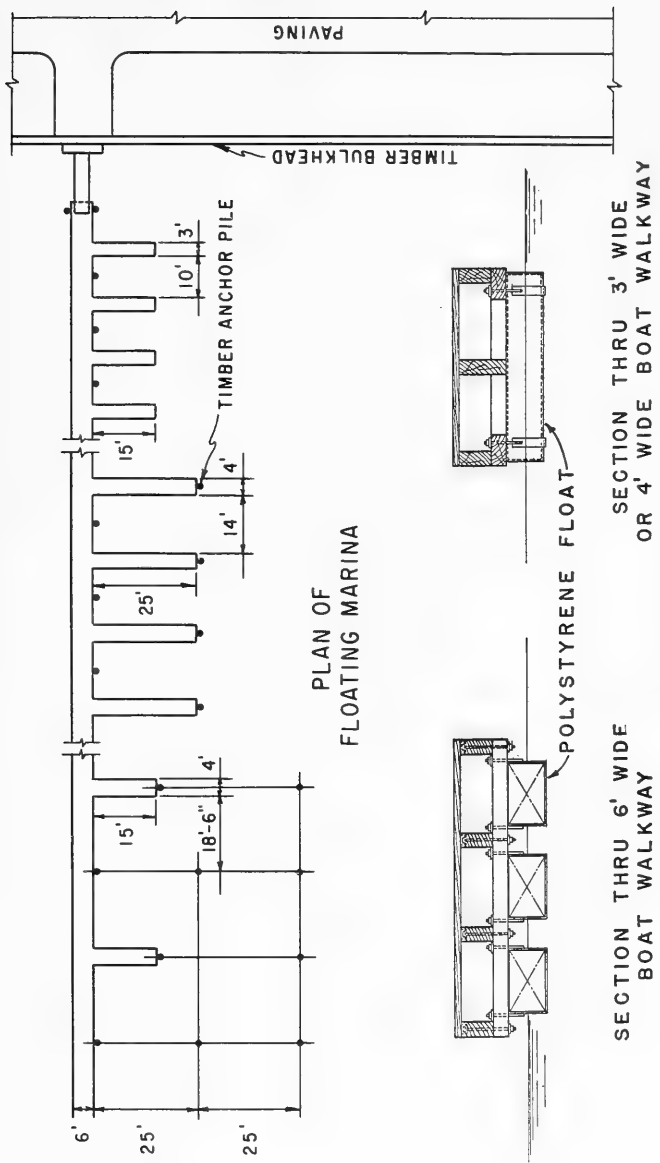

Figure 13. Floating marina.

LITERATURE CITED

- CHELLIS, R.D., *Pile Foundations*, McGraw-Hill, New York, 1961, pp. 332-333.
- TERZAGHI, K., *Theoretical Soil Mechanics*, Wiley and Sons, New York, 1943, pp. 125-231.
- TERZAGHI, K., "Anchored Bulkheads," *Transactions, American Society of Civil Engineers*, Vol. 119, 1954, pp. 1243-1324.
- U.S. ARMY, CORPS OF ENGINEERS, COASTAL ENGINEERING RESEARCH CENTER, *Shore Protection Manual*, Vols. I, II, and III, Stock No. 08022-00077, U.S. Government Printing Office, Washington, D.C., 1973, 1,160 pp.



## APPENDIX

### GLOSSARY

- accretion fillet — a deposit of sediments by littoral currents.
- downdrift — the predominant direction of movement of littoral materials.
- littoral — pertaining to a seashore or coastal region.
- littoral current — a nearshore current, primarily caused by wave action.
- orthogonal — perpendicular to the direction of wave crests.
- spline — a long wooden strip which fits into a recess in the face of a timber member and extends out beyond the face as a tongue.
- updrift — the direction opposite to downdrift.



Ayers, James  
Simplified design methods of treated timber structures for shore,  
beach, and marina construction / by James Ayers and Ralph Stokes. -  
Ft. Belvoir, Va. : U.S. Coastal Engineering Research Center, 1976.  
39 p. : ill. (Miscellaneous report - Coastal Engineering Research  
Center ; no. 76-4)

Bibliography : p. 38.  
Pressure-treated timber has wide application in waterfront and shore  
protection structures built in marina developments and other shore and  
beach locations bordering on bays, lakes, and river resorts, and is  
the principal construction material for bulkheads, seawalls, piers,  
and groins at locations with mild exposure and shallow-to-intermediate  
water depths.

1. Design and construction. 2. Wooden structures. 3. Shore  
protection. 4. Wood. I. Title. II. Stokes, Ralph, joint author.  
III. Series : U.S. Coastal Engineering Research Center.

Miscellaneous report no. 76-4.

TC203 .U581mr no. 76-4 627 .U581mr

Ayers, James  
Simplified design methods of treated timber structures for shore,  
beach, and marina construction / by James Ayers and Ralph Stokes. -  
Ft. Belvoir, Va. : U.S. Coastal Engineering Research Center, 1976.  
39 p. : ill. (Miscellaneous report - Coastal Engineering Research  
Center ; no. 76-4)

Bibliography : p. 38.  
Pressure-treated timber has wide application in waterfront and shore  
protection structures built in marina developments and other shore and  
beach locations bordering on bays, lakes, and river resorts, and is  
the principal construction material for bulkheads, seawalls, piers,  
and groins at locations with mild exposure and shallow-to-intermediate  
water depths.

1. Design and construction. 2. Wooden structures. 3. Shore  
protection. 4. Wood. I. Title. II. Stokes, Ralph, joint author.  
III. Series : U.S. Coastal Engineering Research Center.

Miscellaneous report no. 76-4.

TC203 .U581mr no. 76-4 627 .U581mr

Ayers, James  
Simplified design methods of treated timber structures for shore,  
beach, and marina construction / by James Ayers and Ralph Stokes. -  
Ft. Belvoir, Va. : U.S. Coastal Engineering Research Center, 1976.  
39 p. : ill. (Miscellaneous report - Coastal Engineering Research  
Center ; no. 76-4)

Bibliography : p. 38.  
Pressure-treated timber has wide application in waterfront and shore  
protection structures built in marina developments and other shore and  
beach locations bordering on bays, lakes, and river resorts, and is  
the principal construction material for bulkheads, seawalls, piers,  
and groins at locations with mild exposure and shallow-to-intermediate  
water depths.

1. Design and construction. 2. Wooden structures. 3. Shore  
protection. 4. Wood. I. Title. II. Stokes, Ralph, joint author.  
III. Series : U.S. Coastal Engineering Research Center.

Miscellaneous report no. 76-4.

TC203 .U581mr no. 76-4 627 .U581mr

Ayers, James  
Simplified design methods of treated timber structures for shore,  
beach, and marina construction / by James Ayers and Ralph Stokes. -  
Ft. Belvoir, Va. : U.S. Coastal Engineering Research Center, 1976.  
39 p. : ill. (Miscellaneous report - Coastal Engineering Research  
Center ; no. 76-4)

Bibliography : p. 38.  
Pressure-treated timber has wide application in waterfront and shore  
protection structures built in marina developments and other shore and  
beach locations bordering on bays, lakes, and river resorts, and is  
the principal construction material for bulkheads, seawalls, piers,  
and groins at locations with mild exposure and shallow-to-intermediate  
water depths.

1. Design and construction. 2. Wooden structures. 3. Shore  
protection. 4. Wood. I. Title. II. Stokes, Ralph, joint author.  
III. Series : U.S. Coastal Engineering Research Center.

Miscellaneous report no. 76-4.

TC203 .U581mr no. 76-4 627 .U581mr



<p>Ayers, James Simplified design methods of treated timber structures for shore, beach, and marina construction / by James Ayers and Ralph Stokes. - Ft. Belvoir, Va. : U.S. Coastal Engineering Research Center, 1976. 39 p. : ill. (Miscellaneous report - Coastal Engineering Research Center ; no. 76-4)</p> <p>Bibliography : p. 38. Pressure-treated timber has wide application in waterfront and shore protection structures built in marina developments and other shore and beach locations bordering on bays, lakes, and river resorts, and is the principal construction material for bulkheads, seawalls, piers, and groins at locations with mild exposure and shallow-to-intermediate water depths.</p> <p>1. Design and construction. 2. Wooden structures. 3. Shore protection. 4. Wood. I. Title. II. Stokes, Ralph, joint author. III. Series : U.S. Coastal Engineering Research Center. Miscellaneous report no. 76-4.</p> <p>TC203 .U581mr no. 76-4 627 .U581mr</p>	<p>Ayers, James Simplified design methods of treated timber structures for shore, beach, and marina construction / by James Ayers and Ralph Stokes. - Ft. Belvoir, Va. : U.S. Coastal Engineering Research Center, 1976. 39 p. : ill. (Miscellaneous report - Coastal Engineering Research Center ; no. 76-4)</p> <p>Bibliography : p. 38. Pressure-treated timber has wide application in waterfront and shore protection structures built in marina developments and other shore and beach locations bordering on bays, lakes, and river resorts, and is the principal construction material for bulkheads, seawalls, piers, and groins at locations with mild exposure and shallow-to-intermediate water depths.</p> <p>1. Design and construction. 2. Wooden structures. 3. Shore protection. 4. Wood. I. Title. II. Stokes, Ralph, joint author. III. Series : U.S. Coastal Engineering Research Center. Miscellaneous report no. 76-4.</p> <p>TC203 .U581mr no. 76-4 627 .U581mr</p>
<p>Ayers, James Simplified design methods of treated timber structures for shore, beach, and marina construction / by James Ayers and Ralph Stokes. - Ft. Belvoir, Va. : U.S. Coastal Engineering Research Center, 1976. 39 p. : ill. (Miscellaneous report - Coastal Engineering Research Center ; no. 76-4)</p> <p>Bibliography : p. 38. Pressure-treated timber has wide application in waterfront and shore protection structures built in marina developments and other shore and beach locations bordering on bays, lakes, and river resorts, and is the principal construction material for bulkheads, seawalls, piers, and groins at locations with mild exposure and shallow-to-intermediate water depths.</p> <p>1. Design and construction. 2. Wooden structures. 3. Shore protection. 4. Wood. I. Title. II. Stokes, Ralph, joint author. III. Series : U.S. Coastal Engineering Research Center. Miscellaneous report no. 76-4.</p> <p>TC203 .U581mr no. 76-4 627 .U581mr</p>	<p>Ayers, James Simplified design methods of treated timber structures for shore, beach, and marina construction / by James Ayers and Ralph Stokes. - Ft. Belvoir, Va. : U.S. Coastal Engineering Research Center, 1976. 39 p. : ill. (Miscellaneous report - Coastal Engineering Research Center ; no. 76-4)</p> <p>Bibliography : p. 38. Pressure-treated timber has wide application in waterfront and shore protection structures built in marina developments and other shore and beach locations bordering on bays, lakes, and river resorts, and is the principal construction material for bulkheads, seawalls, piers, and groins at locations with mild exposure and shallow-to-intermediate water depths.</p> <p>1. Design and construction. 2. Wooden structures. 3. Shore protection. 4. Wood. I. Title. II. Stokes, Ralph, joint author. III. Series : U.S. Coastal Engineering Research Center. Miscellaneous report no. 76-4.</p> <p>TC203 .U581mr no. 76-4 627 .U581mr</p>



