

UNIVERSITY OF TORONTO



3 1761 01540706 7

# SOIL FERTILITY LABORATORY MANUAL

HOPKINS ▲ PETTIT

S  
593  
H66

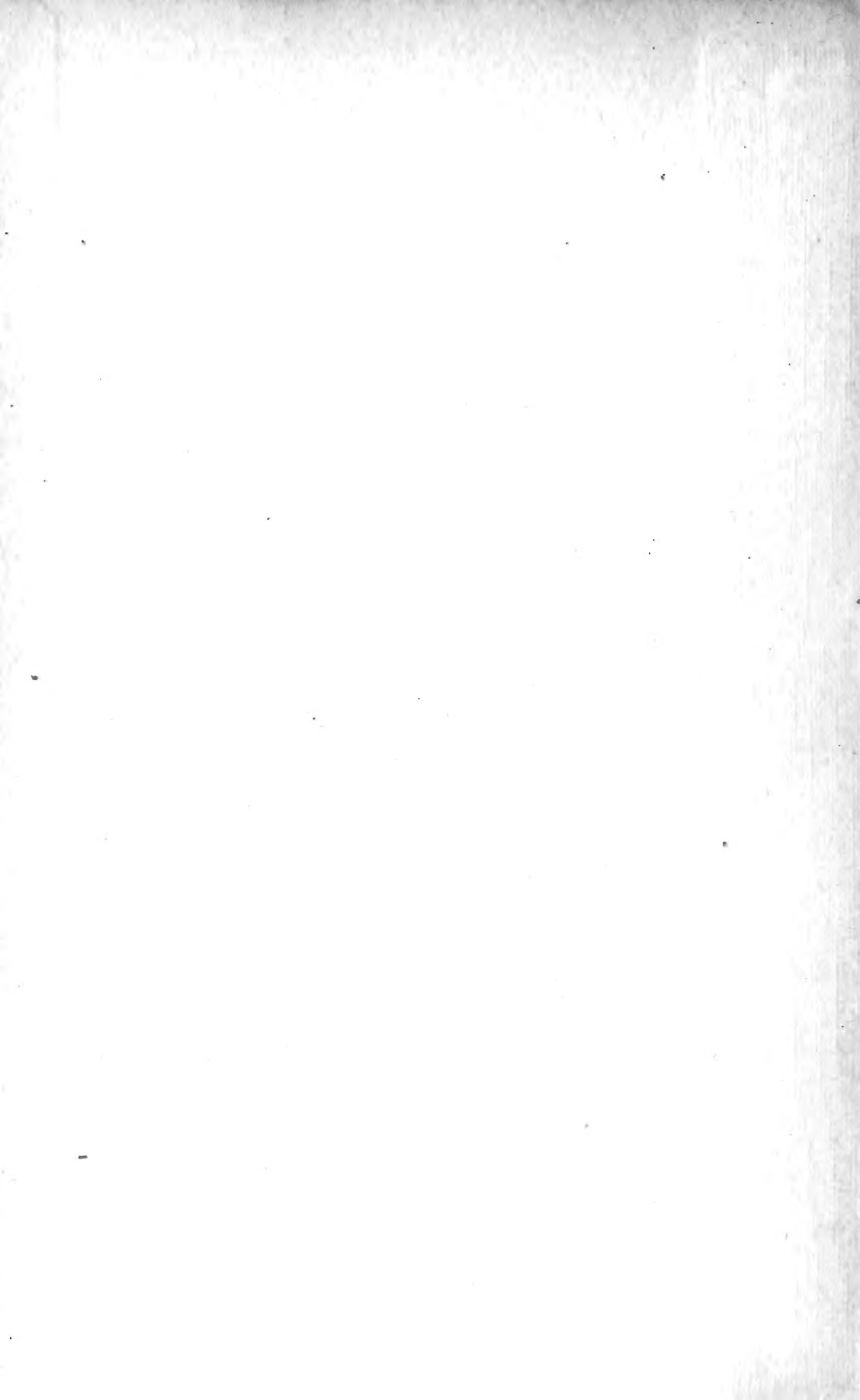

LIBRARY  
FACULTY OF FORESTRY  
UNIVERSITY OF TORONTO

Digitized by the Internet Archive  
in 2007 with funding from  
Microsoft Corporation

# SOIL FERTILITY LABORATORY MANUAL

BY

CYRIL G. HOPKINS, PH.D.

PROFESSOR OF AGRONOMY IN THE UNIVERSITY OF ILLINOIS

AND

JAMES H. PETTIT, PH.D.

ASSISTANT PROFESSOR OF SOIL FERTILITY IN THE UNIVERSITY OF ILLINOIS

155237  
8/6/20

GINN AND COMPANY

BOSTON · NEW YORK · CHICAGO · LONDON

COPYRIGHT, 1910, BY  
CYRIL G. HOPKINS AND JAMES H. PETTIT

ALL RIGHTS RESERVED

311.6

S  
593  
H66

SEEN BY  
PRESERVATION

**The Athenæum Press**  
GINN AND COMPANY · PROPRIETORS · BOSTON · U.S.A.

## PREFATORY NOTE

The student practices described in this laboratory manual are the result of ten years' experience by the authors in conducting classes in a course of study in soil fertility. With some modifications the usual chemical methods are employed, specific chemical directions being commonly based upon those adopted by the Association of Official Agricultural Chemists. Otherwise these practices were originated in this University.

The increasing number of students in this institution, and the fact that some other institutions also use our manual, induced us to put it in printed form.

Suggestions from other teachers of soil fertility regarding possible improvements in the manual will be gladly received.

THE AUTHORS

UNIVERSITY OF ILLINOIS, URBANA





TABLE I  
ELEMENTS, SYMBOLS, AND INTERNATIONAL ATOMIC WEIGHTS  
FOR 1910

NAME	SYMBOL	ATOMIC WEIGHT	NAME	SYMBOL	ATOMIC WEIGHT
Aluminum . . . . .	Al	27.1	Lead (Plumbum) . . .	Pb	207.1
Antimony (Stibium) . .	Sb	120.2	Lithium . . . . .	Li	7.0
Argon . . . . .	A	39.9	Magnesium . . . . .	Mg	24.3
Arsenic . . . . .	As	75.0	Manganese . . . . .	Mn	54.9
Barium . . . . .	Ba	137.4	Mercury (Hydrargyrum)	Hg	200.0
Bismuth . . . . .	Bi	208.0	Molybdenum . . . . .	Mo	96.0
Boron . . . . .	B	11.0	Nickel . . . . .	Ni	58.7
Bromin . . . . .	Br	79.9	Nitrogen. . . . .	N	14.0
Cadmium. . . . .	Cd	112.4	Oxygen . . . . .	O	16.000
Calcium . . . . .	Ca	40.1	Phosphorus . . . . .	P	31.0
Carbon . . . . .	C	12.0	Platinum . . . . .	Pt	195.0
Chlorin . . . . .	Cl	35.5	Potassium (Kalium) . .	K	39.1
Chromium . . . . .	Cr	52.0	Silicon . . . . .	Si	28.3
Cobalt. . . . .	Co	59.0	Silver (Argentum) . .	Ag	107.9
Copper (Cuprum) . . .	Cu	63.6	Sodium (Natrium) . .	Na	23.0
Fluorin . . . . .	F	19.0	Strontium . . . . .	Sr	87.6
Gold (Aurum) . . . .	Au	197.2	Sulfur . . . . .	S	32.1
Hydrogen . . . . .	H	1.008	Tin (Stannum) . . . .	Sn	119.0
Iodin . . . . .	I	126.9	Titanium . . . . .	Ti	48.1
Iron (Ferrum) . . . .	Fe	55.9	Zinc . . . . .	Zn	65.4

TABLE II  
NITRIC ACID IN SOLUTIONS OF DIFFERENT SPECIFIC GRAVITY AT 15° C.

SPECIFIC GRAVITY	GRAMS HNO <sub>3</sub> IN 100 CC.	SPECIFIC GRAVITY	GRAMS HNO <sub>3</sub> IN 100 CC.	SPECIFIC GRAVITY	GRAMS HNO <sub>3</sub> IN 100 CC.
1.09	16.9	1.23	45.2	1.37	81.4
1.10	18.8	1.24	47.5	1.38	84.6
1.11	20.7	1.25	49.8	1.39	87.9
1.12	22.7	1.26	52.1	1.40	91.4
1.13	24.6	1.27	54.4	1.41	95.2
1.14	26.6	1.28	56.8	1.42	99.1
1.15	28.6	1.29	59.3	1.43	103.2
1.16	30.6	1.30	61.7	1.44	107.5
1.17	32.6	1.31	64.3	1.45	112.1
1.18	34.7	1.32	66.9	1.46	116.8
1.19	36.7	1.33	69.7	1.47	121.9
1.20	38.8	1.34	72.5	1.48	127.4
1.21	40.9	1.35	75.3	1.49	133.5
1.22	43.0	1.36	78.3	1.50	141.1

TABLE III

AMMONIA IN SOLUTIONS OF AMMONIUM HYDROXID OF DIFFERENT SPECIFIC GRAVITY AT 15° C.

SPECIFIC GRAVITY	GRAMS NH <sub>3</sub> IN 100 CC.	SPECIFIC GRAVITY	GRAMS NH <sub>3</sub> IN 100 CC.	SPECIFIC GRAVITY	GRAMS NH <sub>3</sub> IN 100 CC.
.940	14.69	.920	20.01	.900	25.50
.938	15.21	.918	20.56	.898	26.05
.936	15.74	.916	21.09	.896	26.60
.934	16.27	.914	21.63	.894	27.15
.932	16.81	.912	22.19	.892	27.70
.930	17.34	.910	22.74	.890	28.26
.928	17.86	.908	23.29	.888	28.86
.926	18.42	.906	23.83	.886	29.46
.924	18.93	.904	24.39	.884	30.14
.922	19.47	.902	24.94	.882	30.83

TABLE IV

HYDROCHLORIC ACID IN SOLUTIONS OF DIFFERENT SPECIFIC GRAVITY AT 15° C.

SPECIFIC GRAVITY	GRAMS HCl IN 100 CC.	SPECIFIC GRAVITY	GRAMS HCl IN 100 CC.	SPECIFIC GRAVITY	GRAMS HCl IN 100 CC.
1.040	8.5	1.095	20.9	1.150	34.0
1.045	9.6	1.100	22.0	1.155	35.3
1.050	10.7	1.105	23.2	1.160	36.6
1.055	11.8	1.110	24.3	1.165	37.9
1.060	12.9	1.115	25.5	1.170	39.2
1.065	14.1	1.120	26.7	1.175	40.4
1.070	15.2	1.125	27.8	1.180	41.8
1.075	16.3	1.130	29.1	1.185	43.0
1.080	17.4	1.135	30.3	1.190	44.3
1.085	18.6	1.140	31.5	1.195	45.6
1.090	19.7	1.145	32.8	1.200	46.9

## LIST OF APPARATUS

- |   |   |
|---|---|
| 1 Double condenser with connecting tubing | 1 Camel's-hair brush                                    |
| 2 Ring stands                             | 1 Measuring flask, 250 cc.                              |
| 6 Rings, 4 sizes                          | 1 Measuring flask, 500 cc.                              |
| 3 Iron gauze with asbestos center         | 1 Bone spoon  |
| 2 Safety distillation bulbs               | 1 Forceps   |
| 3 Pinchcocks                              | 1 Thermometer, 100°                                     |
| 4 Rubber stoppers                         | 2 Bunsen burners with connecting tubing                 |
| 2 Triangles, pipestem                     | 1 Adjustable burner with connecting tubing              |
| 2 Erlenmeyer flasks, 200 cc.              | 1 Burette clamp   |
| 2 Erlenmeyer flasks, 300 cc.              | 1 Apparatus clamp                                       |
| 4 Beakers, Jena, 250 cc.                  | 4 Kjeldahl flasks, 500 cc.                              |
| 4 Beakers, Jena, 400 cc.                  | 2 Bottles, 250 cc.                                      |
| 2 Crucibles, 14 cc.                       | 2 Bottles, 500 cc.                                      |
| 2 Crucibles, 25 cc.                       | 2 Bottles, 1000 cc.                                     |
| 4 Funnels, 6 cm.                          | 1 Bottle, 2500 cc.                                      |
| 2 Funnels, 10 cm.                         | 2 Wash bottles, Jena, 1000 cc.                          |
| 1 Crucible tongs                          | 1 Desiccator, 12 cm. diameter                           |
| 2 Evaporating dishes, 8 cm.               | 3 Percolators, 1000 cc. capacity                        |
| 2 Evaporating dishes, 10 cm.              | 4 Stirring rods   |
| 1 Graduated cylinder, 25 cc.              | 1 Screw clamp   |
| 1 Graduated cylinder, 100 cc.             | 2 Quart jars  |
| 1 Graduated pipette, 25 cc.               | 1 Rubber policeman                                      |
| 1 Pipette, 25 cc.                         | 1 Weighing pan  |
| 1 Pipette, 10 cc.                         | 2 Iron crucibles of about 100 cc. capacity, with covers |
| 1 Burette, 50 cc.                         |   |
| 2 Test tubes                              |   |
| 2 Watch glasses, 10 cm.                   |   |

## PRACTICE I

### PREPARATION OF STANDARD HYDROCHLORIC ACID SOLUTION<sup>1</sup>

By the use of a hydrometer and the specific-gravity table prepare 5 liters or more of approximately one half normal hydrochloric acid, using chemically pure concentrated acid and ammonia-free water.

Standardize by the silver nitrate method: Place exactly 25 cc. (note temperature of stock solution when measured out) of the acid solution, measured with a pipette, in a 300-cc. Erlenmeyer flask, dilute to 75 cc., and add at once from a burette sufficient 5 per cent silver nitrate solution to nearly, but not quite, precipitate all the chlorin. Close the flask with a clean rubber stopper and shake till the precipitate will settle almost completely in a short time. Then add the silver nitrate in 1-cc. portions, shaking after each addition, until the precipitation is complete, avoiding more than 1 cc. excess of silver nitrate solution.

Shake until the silver chlorid settles well, wash three times by decantation (after shaking each time), using about 100 cc. of water containing 1 cc. concentrated nitric acid per liter, and decanting the liquid through a 9-cm. filter. Transfer the precipitate to the filter, dry, transfer the bulk of the precipitate to a watch glass or crucible, and burn the paper in a weighed crucible. Add 2 to 5 drops of concentrated nitric acid to dissolve reduced silver, and then add 2 to 5 drops of concentrated hydrochloric acid. Evaporate to dryness without spattering, add the main precipitate, dry to constant weight at 120° to 130°, cool in a desiccator, and weigh.

Record the weights of silver chlorid from duplicate 25-cc. portions of the standard hydrochloric acid.

<sup>1</sup> To be done by the instructor.

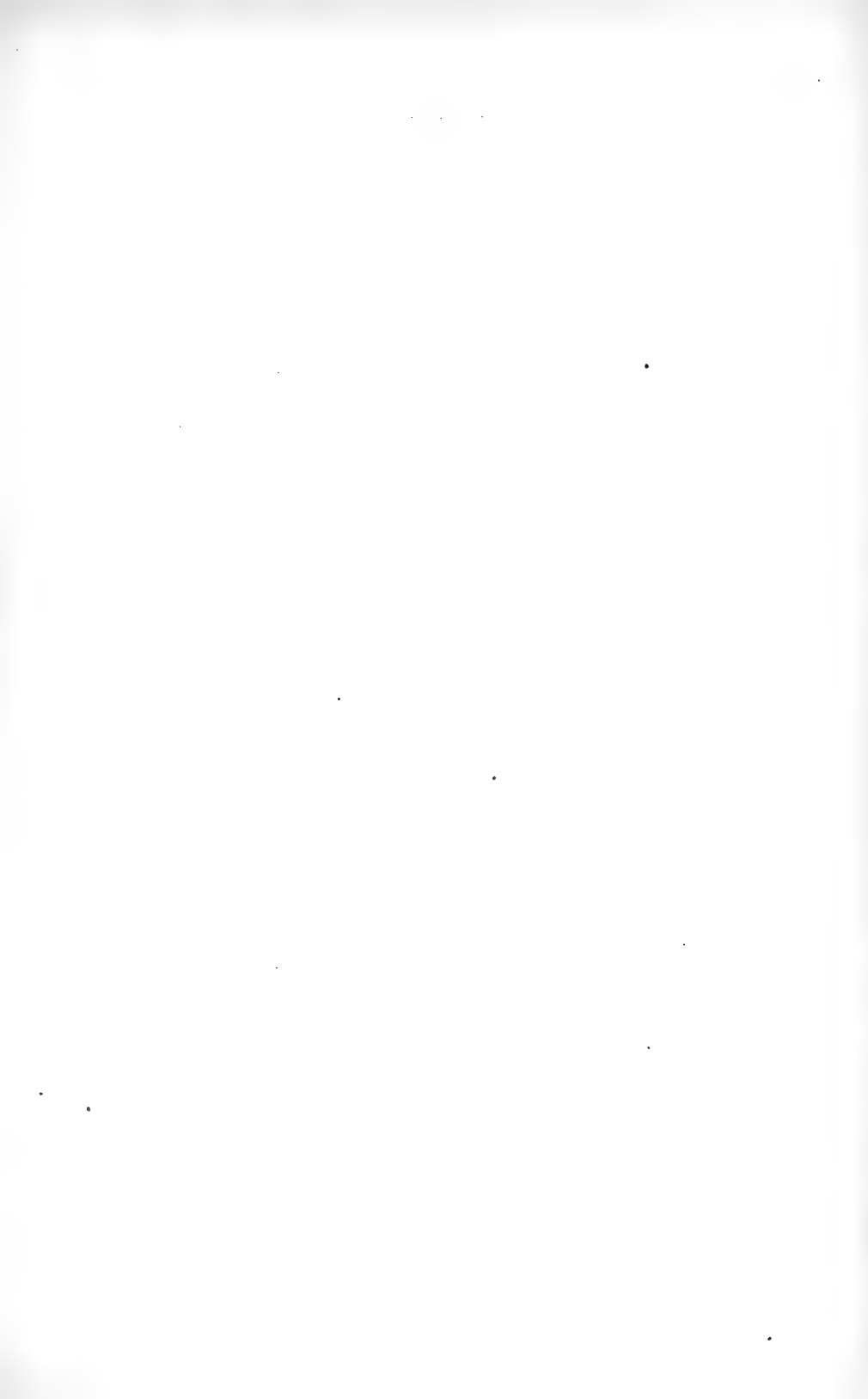

## PRACTICE II

### PREPARATION OF A STANDARD AMMONIA SOLUTION

Determine, by hydrometer, the specific gravity of concentrated ammonia, and calculate, by the use of the specific-gravity table, the number of cubic centimeters necessary to make 2 liters of approximately one fifth normal ammonia solution.

Sp. gr. ....  
Grams  $\text{NH}_3$  per cc. ....  
Grams  $\text{NH}_3$  per liter in normal solution.....  
Grams  $\text{NH}_3$  in 2 liters of 1-5 normal solution.....  
No. of cc. of conc.  $\text{NH}_3$  equivalent to.....g.  $\text{NH}_3$ .....

Measure out the required amount of concentrated ammonia, add water to make the total volume up to 2 liters, and mix thoroughly. Standardize by titrating 10 cc. of the standard hydrochloric acid with the ammonia solution, using lacmoid as an indicator. Make three titrations:

(1) 10 cc. HCl is equivalent to.....cc.  $\text{NH}_3$   
(2) 10 cc. HCl is equivalent to.....cc.  $\text{NH}_3$   
(3) 10 cc. HCl is equivalent to.....cc.  $\text{NH}_3$   
Av. ....cc.  $\text{NH}_3$   
1 cc.  $\text{NH}_3$  is equivalent to.....mg. N.

Give reactions in first and second practices, and record the computations involved in ascertaining the weight of nitrogen in 1 cc. of the standard ammonia solution.



### PRACTICE III

#### BLANK DETERMINATION OF NITROGEN IN REAGENTS USED IN DISTILLING

Place 250 cc. of ammonia-free water in a Kjeldahl flask and connect latter in the distillation apparatus shown in the figure on the opposite page. Arrange the 300-cc. Erlenmeyer flask *K*, containing 10 cc. of the standard hydrochloric acid and about 15 cc. of ammonia-free water, so that the end of the delivery tube *J* dips into the solution. By disconnecting at *D* and inserting a funnel in the rubber tube, bring 10 cc. of an alkali solution (1000 g. Greenbank alkali and 25 g. potassium sulfid in 1000 cc. water) into the Kjeldahl flask. Close the pinchcock *E*, shake the flask thoroughly, and connect with the steam generator *C*. Open the pinchcock *E* and close *A*, thus forcing steam through the flask and carrying the liberated ammonia over into the standard acid. Heat the Kjeldahl flask sufficiently to prevent condensation of the steam. Distil to a volume of 200 cc., add laemoid, and titrate with the standard ammonia solution.

- (1) Titration.....cc.  $\text{NH}_3$   
(2) Titration.....cc.  $\text{NH}_3$   
    Av. ....cc.  $\text{NH}_3$

State correction in cubic centimeters of standard ammonia solution.  
What does this mean, and how is it to be used?



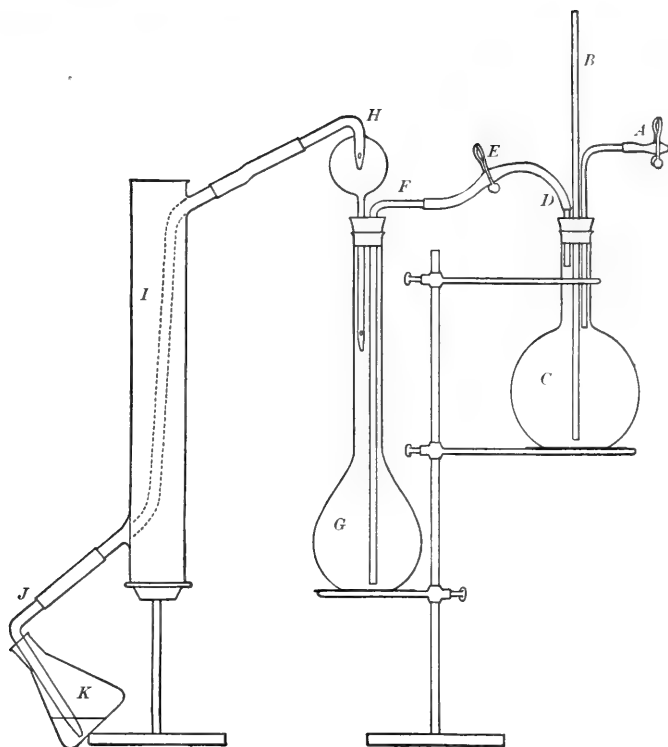

FIG. 1. Distillation Apparatus for the Nitrogen Determination

The apparatus shown in Fig. 1 has been found very convenient in student laboratories. *C* is a liter flask to be used as a steam generator. Its rubber stopper carries the glass tube *B*, which acts as a safety valve; a second glass tube, on the end of which is a piece of rubber tubing and the pinchcock *A*; and a third glass tube, connecting, by means of the rubber tubing *D*, with the glass tube *F*. The latter goes nearly to the bottom of the Kjeldahl flask *G*, which is connected with the block-tin tube of the condenser *I* through the Hopkins safety distillation bulb *H*. *K* is a receiving flask containing the standard acid. By means of a Y-tube in place of the third glass tube in the stopper of *C*, two Kjeldahl flasks for duplicate determinations may be connected with the latter

## PRACTICE IV

### DETERMINATION OF NITROGEN IN REAGENTS

Measure out exactly 10 cc. of the concentrated alkali in a beaker and dilute to 200 cc. with distilled water. Stir and add slowly, finally drop by drop, concentrated sulfuric acid until the alkali is neutralized, as shown by the change of color.

10 cc. alkali are equivalent to.....cc.  $H_2SO_4$

How many cubic centimeters of alkali are necessary to neutralize 20 cc.  $H_2SO_4$ ?

Place approximately 2 g. of pure sugar in a Kjeldahl flask, add by measure approximately .65 g. metallic mercury and 20 cc. sulfuric acid. Digest in a ventilated hood over a low flame till colorless, and while still boiling hot carefully add powdered potassium permanganate until the solution is green. Allow to cool. Add 200 cc. of ammonia-free water, connect in the distillation apparatus, add carefully sufficient concentrated alkali to neutralize 20 cc. of concentrated sulfuric acid, shake until thoroughly mixed, and distill, using 10 cc. of standard acid in the receiver.

(1) Titrations .....cc.  $NH_3$

(2) Titrations.....cc.  $NH_3$

Av. ....cc.  $NH_3$

Check up the standard ammonia solution by titrating against the standard hydrochloric acid solution.

Correction for nitrogen in reagents in terms of standard ammonia solution.....cc.

Explain the use of the sugar. Give the reaction between the sugar and the sulfuric acid. Why is the mercury used? the potassium permanganate? the potassium sulfid?

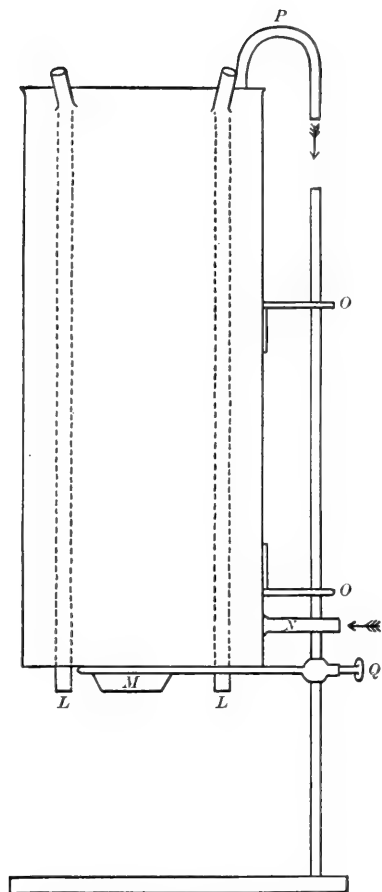

FIG. 2

Fig. 2 shows more in detail the condenser of the distillation apparatus and the way in which it is supported. It consists of a rectangular galvanized-iron box ( $16'' \times 6'' \times 3''$ ), through which pass two block-tin tubes *L, L*. *N* is the inlet and *P* the outlet for the condensing water. It is supported by the ring *Q* of an iron stand, through which passes the projection *M*. The holes in the right-angled pieces *O, O* allow the rod of the iron stand to pass through readily.

## PRACTICE V

### DETERMINATION OF NITROGEN IN FARM PRODUCE

Each group of students will work upon one of the following materials:<sup>1</sup>

- |                 |                    |
|-----------------|--------------------|
| 1. Wheat.       | 5. Oats.           |
| 2. Corn.        | 6. Oat straw.      |
| 3. Corn stover. | 7. Red-clover hay. |
| 4. Corneobs.    | 8. Alfalfa.        |

Weigh out exactly 2 g. of the material numbered with your group number and determine the nitrogen in it according to the method given in Practice IV.

Titrations.....	cc. NH <sub>3</sub>
Titrations.....	cc. NH <sub>3</sub>
Av.....	cc. NH <sub>3</sub>
Per cent N.....	
Pounds per ton.....	

Calculate the results obtained, and with these record the results obtained by three members of each group as indicated upon the following page, valuing nitrogen at 15 cents per pound. How many tons of red clover must be plowed under in order to supply in this way the nitrogen for a 100-bushel crop of corn and a 100-bushel crop of oats in a corn, oats, and clover rotation?

Compute the pounds of nitrogen required to produce the crops given in the table below. Compute the weight of sodium nitrate (95 per cent pure) which would supply the nitrogen found in these crops, and the cost of the same.

KIND OF PRODUCE	POUNDS N IN PRODUCE	POUNDS NaNO <sub>3</sub> EQUIVALENT	COST OF NaNO <sub>3</sub>
(1) 100 bu. shelled corn . . . . .			
(2) 1000 lb. cobs . . . . .			
(3) Stover, weight equal to (1)+(2) .			
(4) 100 bu. oats . . . . .			
(5) 5000 lb. oat straw . . . . .			
(6) 4 tons clover hay . . . . .			
Total for three crops . . . . .			

<sup>1</sup> These or other stock materials of large importance in agriculture should be furnished by the laboratory in finely pulverized, air-dry condition. The student is encouraged to determine nitrogen in some other produce which may be of special local interest in his home community.



## PRACTICE VI

### DETERMINATION OF NITROGEN IN SOILS

Each group of students will work upon one stock soil, such as the following:<sup>1</sup>

- |                                |                                |
|--------------------------------|--------------------------------|
| 1. Surface of gray silt loam.  | 5. Surface of black clay loam. |
| 2. Subsoil of gray silt loam.  | 6. Subsoil of black clay loam. |
| 3. Surface of brown silt loam. | 7. Sandy soil.                 |
| 4. Subsoil of brown silt loam. | 8. Peaty soil (use 2 g.).      |

For all soils except peat weigh out 10 g. of air-dry soil and use 10 cc. of standard hydrochloric acid in the receiver.

(1) Titration.....	cc. $\text{NH}_3$
(2) Titration.....	cc. $\text{NH}_3$
Av.....	cc. $\text{NH}_3$
Per cent N .....	

Calculate the results obtained, and with these record the results obtained by three members of each group as indicated upon the following page.

Assuming that there are 2,000,000 pounds in an acre to the depth of  $6\frac{3}{4}$  inches, how many pounds of nitrogen are there in this plowed soil? How many 100-bushel crops of corn will this produce if the total crop is removed?

<sup>1</sup> These are types of soil which can easily be found in almost every state in the North Central group; but in other sections the important and extensive type soils of the state should be substituted for some of these.



## PRACTICE VII

### DETERMINATION OF THE REACTION OF A SOIL

Each group of students will work upon one of a group of soils selected by the instructor, using surface and subsoil samples.

Place about 10 g. of soil in a Jena-glass flask with 100 cc. of ammonia-free water, shake thoroughly several times, and allow to stand over night. Draw off 50 cc. of the supernatant liquid, add a few drops of phenolphthalein, and concentrate in a Jena-glass beaker to about 10 cc., if a pink color does not develop before this point is reached.

To what is the development of a pink color in the solution due?

What is the condition of the soil when no color appears?

If no pink color develops, determine acidity as directed in Practice IX.

If a pink color develops, determine the limestone present according to directions given in Practice X.





## PRACTICE VIII

### PREPARATION OF STANDARD SODIUM HYDROXID AND NORMAL POTASSIUM NITRATE SOLUTIONS<sup>1</sup>

These solutions are to be used in the determination of soil acidity.

1. Weigh out enough sodium hydroxid (sticks, purified over alcohol, about 75 per cent NaOH) to make about 3 liters of solution of such strength that 1 cc. shall be equivalent to 4 mg. of calcium carbonate. Dissolve in ammonia-free water, dilute to exactly 1000 cc., add 100 cc. of a saturated barium hydroxid solution, shake well, and allow to stand over night, or until clear. Draw off 100 cc. of the clear solution, and place in a 250-cc. bottle containing 100 cc. of the saturated solution of barium hydroxid. If a precipitate occurs, add the 200 cc. to the main solution, shake, and repeat the above operations until no further precipitate occurs. (If no precipitate is formed, throw away the 200 cc.) Always keep an exact record of the amount of liquid remaining in the stock bottle. When the solution is free from carbon dioxid, draw off 100 cc. and place in a 100-cc. bottle. Fill the burette with this and titrate against 10-cc. portions of standard hydrochloric acid. Add ammonia-free water so that 1 cc. of the standard sodium hydroxid solution shall be exactly equivalent to 4 mg. of calcium carbonate.

2. Prepare 5 liters of a normal potassium nitrate solution, assuming the salt to be pure.

If 100 g. of an acid soil are placed in 250 cc. of normal potassium nitrate solution and shaken for three hours, a reaction takes place between the potassium nitrate and the acid constituents of the soil, giving, as one of the products, soluble acid salts, and so making the acidity determinable. An equilibrium is reached, however, before this reaction runs to an end; and if, after having drawn off 125 cc. to titrate, 125 cc. of fresh potassium nitrate are added to the bottle and the bottle again shaken for three hours, 125 cc. drawn off will give a titration which is more than one half of the first. By continuing this process until the last 125 cc. shows practically no acidity, we have a series of titrations the sum of which represents the total acidity of the 100 g. of soil. It has been found by working with a number of different soils that, as an average, the sum of such a series is two and one-half times the first titration.

Consequently, when the sodium hydroxid is made up so that 1 cc. is equivalent to 4 mg. of calcium carbonate, and 125 cc. (which represent 50 g. of soil) are titrated, each 0.1 cc. required to neutralize corresponds to 1 mg. of calcium carbonate required by the 100 g. of soil, or to 0.001 per cent of calcium carbonate required by the soil tested.

<sup>1</sup> To be done by the instructor.

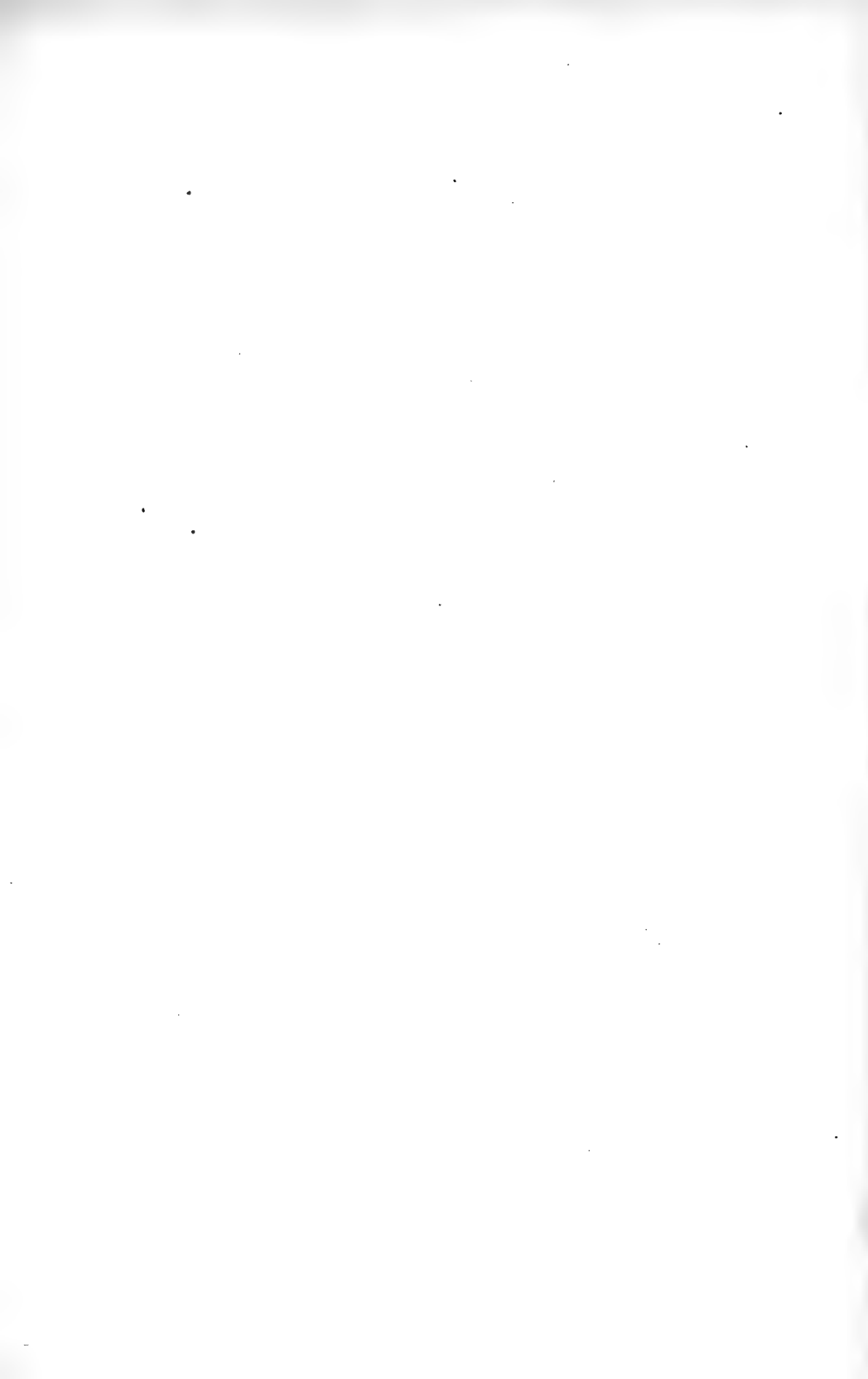

## PRACTICE IX

### DETERMINATION OF ACIDITY (OR LIMESTONE REQUIRED) OF SOILS

Place 100 g. of soil in a 400-cc. (or 12-oz.) wide-mouthed bottle, add 250 cc. normal potassium nitrate solution, stopper, and shake continuously for three hours in a shaking machine, or every five minutes by hand. Let stand over night. Draw off 125 cc. of the clear supernatant liquid, boil ten minutes to expel carbon dioxide, cool, and titrate with the standard sodium hydroxid, using phenolphthalein as indicator.

	<i>Surface</i>	<i>Subsoil</i>	
(1) Titrations	.....	.....	cc. NaOH
(2) Titrations	.....	.....	cc. NaOH
Av.	.....	.....	cc. NaOH
Per cent CaCO <sub>3</sub> required	.....	.....	

What crops, and in what way, does ground limestone mainly benefit?

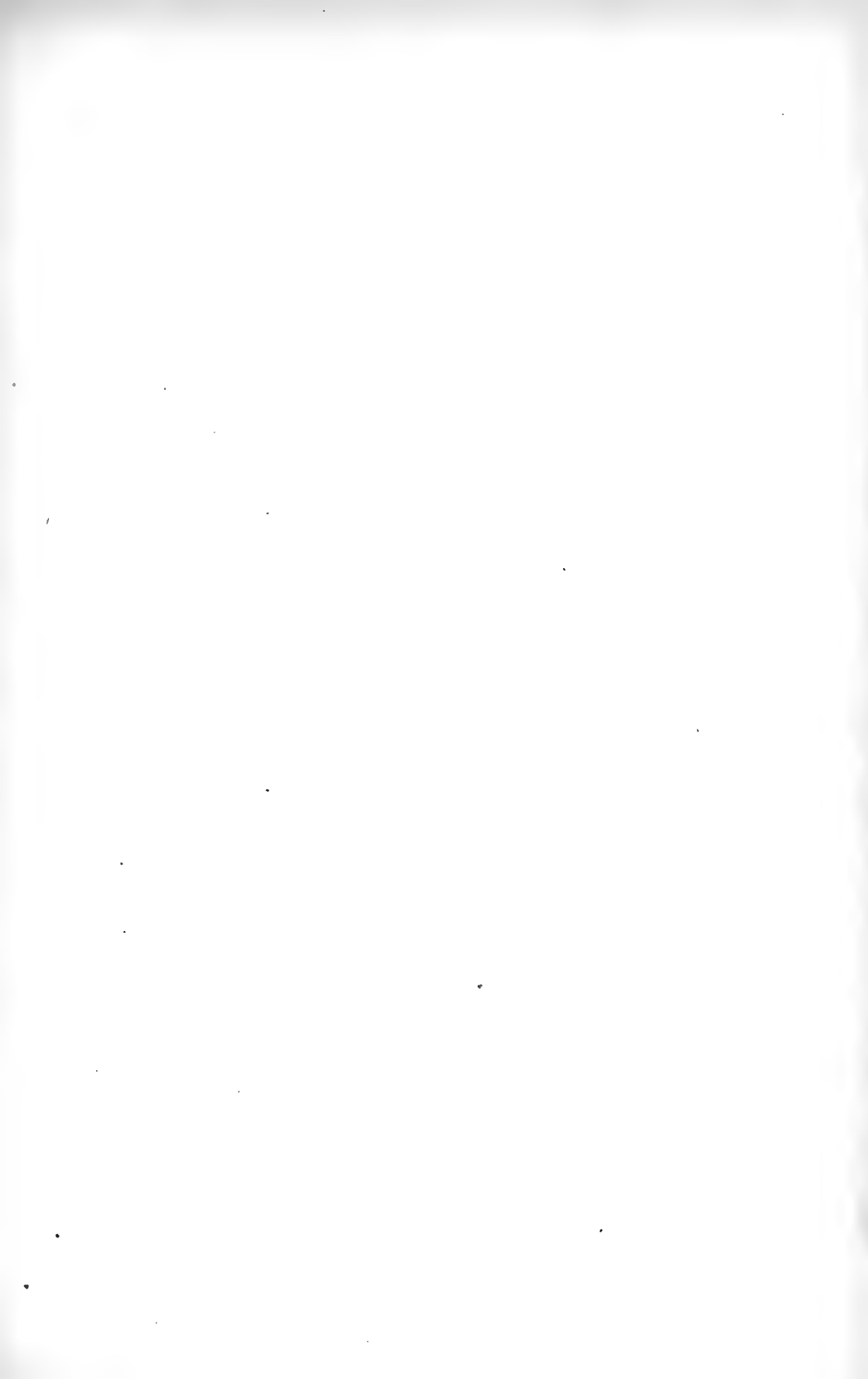

## PRACTICE X

### DETERMINATION OF THE INORGANIC CARBON (OR LIMESTONE PRESENT) IN A SOIL

Use the apparatus referred to in Practice XXX for organic carbon.

Place from 2 to 10 g. of soil, according to the amount of carbonates present, in the Erlenmeyer flask. Connect with the apparatus and bring in slowly through the separatory funnel an excess of dilute (1 : 1) hydrochloric acid. After the reaction is over, boil the contents of the flask to drive out dissolved carbon dioxide, fill with water through the separatory funnel, measure the volume of gas in the burette, and pass same into an absorption pipette containing a 33 per cent solution of potassium hydroxid. Return the unabsorbed gas to the burette and read off its volume. The difference between the readings is carbon dioxide, whose volume must be corrected for temperature and pressure.

	(1)	(2)
cc. of CO <sub>2</sub>	.....	.....
Barometer and temperature	.....	.....
Weight of C equivalent	.....	.....
Weight of CaCO <sub>3</sub> equivalent	.....	.....
Per cent of CaCO <sub>3</sub> present	.....	.....
Average	.....	

Calculate the results obtained in Practices IX and X, and with these record the results obtained by three members of each group as indicated upon the following page. Consider 6½ acre-inches of normal soil to weigh 2,000,000 pounds.



## PRACTICE XI

### PREPARATION OF PLANT-FOOD SOLUTIONS<sup>1</sup>

*Solution No. 1.* Nitrogen: Dissolve 80 g. of ammonium nitrate in 2500 cc. of distilled water. Use 10 cc. per pot.

*Solution No. 2.* Phosphorus: Dissolve 25 g. of monocalcium phosphate or 26 g. of disodium phosphate in 2500 cc. of ammonia-free water. Use 10 cc. per pot.

*Solution No. 3.* Potassium: Dissolve 50 g. of potassium sulfate in 2500 cc. of ammonia-free water. Use 10 cc. per pot.

*Solution No. 4.* Magnesium: Dissolve 20 g. of magnesium sulfate in 2500 cc. of ammonia-free water. Use 10 cc. per pot.

*Solution No. 5.* Iron: Dissolve 0.1 g. ferric chlorid in 250 cc. of ammonia-free water. Use 1 cc. per pot.

Prepare these solutions carefully, using chemically pure salts, and label each bottle.

<sup>1</sup> To be done by the instructor.





## PRACTICE XII

### PREPARATION OF POT CULTURES

Use clean, white, sifted quartz sand in 5-liter heavy glass battery jars, having a 1-cm. hole within 1 cm. of the bottom. Into the hole fit a drain tube made of glass tubing with a glass-wool filter at the inner end, so that it will drain from the lowest part of the jar. Put up a series of eight of these pots, to be used as indicated in the table on the following page.

To extract the sand, fill the jar within 1 cm. of the top with dry sifted sand and add to this dilute sulfuric acid (made by adding 100 cc. of concentrated chemically pure sulfuric acid to 900 cc. of ammonia-free water) until the sand is saturated. Let stand two hours and then add ammonia-free water, allowing the drainage to flow into a second jar until it is saturated. Allow this jar to stand two hours and then wash both with ammonia-free water until free from acid.

After drying, mix with the sand of each pot 10 g. of pure calcium carbonate.

In making applications of plant food as indicated in the following table, and in such amounts as are shown in Practice XI, bring the solutions to be applied to each pot into about 1 liter of water, mix thoroughly, and apply the whole amount to the pot, allowing any water present to be forced out through the drain.

The first application of plant food is to be made at the time of planting, the second three weeks later, the third two weeks later, and subsequent applications at intervals of one week, each time making the application as directed above.

Each student in each group will prepare and care for a series of pots, as indicated in the following table.

PRACTICE XII (CONTINUED)

POT No.	PREPARATION OF SAND	PLANT FOOD ADDED	SEEDS PLANTED IN GROUPS							
			1	2	3	4	5	6	7	8
1	Extract and wash	None	Corn	Oats	Wheat	Barley	Buck-wheat	Millet	Rape	Flax
2	"	All but N	"	"	"	"	"	"	"	"
3	"	All but P	"	"	"	"	"	"	"	"
4	"	All but K	"	"	"	"	"	"	"	"
5	None	All	"	"	"	"	"	"	"	"
6	"	All	Red Clover	Cow-peas	Soy Beans	Vetch	Alfalfa	Sweet Clover	Crimson Clover	Alsike Clover
7 <sup>1</sup>	"	All but N	"	"	"	"	"	"	"	"
8	"	All but N Bacteria <sup>2</sup>	"	"	"	"	"	"	"	"

<sup>1</sup> In accurate work this pot should be covered with a layer of cotton, heated in an autoclave two hours at 125°, and planted with sterilized seed, assisting the young plants to push up through the cotton.

<sup>2</sup> Obtain about 0.5 kg. of soil which has recently grown the infected legume, and shake it up with about 1 liter of water. Let settle, and with each seed as it is planted add 10 cc. of the supernatant liquid before the seed is covered.

Why is the CaCO<sub>3</sub> added? Make observations and at least weekly notes of any differences in growth, and explain.









## PRACTICE XIII

### PREPARATION OF AN AMMONIUM SULFATE SOLUTION

Weigh out exactly in a weighed crucible the number of grams of chemically pure ammonium sulfate (assuming the salt to be dry) equivalent to 1000 cc. of the standard ammonia solution. Dry in the air bath at  $115^{\circ}$  to  $120^{\circ}$  for thirty minutes, cool in a desiccator, and weigh. Dissolve in ammonia-free water in a 500-cc. measuring flask. Dilute to exactly 500 cc. Mix well and transfer to a dry 500-cc. bottle. Label and keep stoppered when not in use.

1000 cc. standard  $\text{NH}_3$  contains.....g. N

Per cent N in  $(\text{NH}_4)_2\text{SO}_4$  by theory is.....

1000 cc.  $\text{NH}_3$  is equivalent to.....g.  $(\text{NH}_4)_2\text{SO}_4$

	<i>Before heating</i>	<i>After heating</i>
Weight of crucible + $(\text{NH}_4)_2\text{SO}_4$ = .....	= .....	= .....
Weight of crucible = .....	= .....	= .....
Weight of $(\text{NH}_4)_2\text{SO}_4$ = .....	= .....	= .....
Per cent dry matter in salt is.....		

How much of the ammonium sulfate will it be necessary to weigh out in order to have exactly 5 g. of the dry salt ?





## PRACTICE XIV

### DETERMINATION OF NITROGEN IN AMMONIUM SULFATE

Place 10 cc. of the ammonium sulfate solution in a Kjeldahl flask, connect in the distillation apparatus, add 10 cc. of the alkali solution, and distill into a 300-cc. Erlenmeyer flask containing 10 cc. of the standard hydrochloric acid and about 15 cc. of ammonia-free water to a volume of 200 cc. Add lacmoid and titrate the excess acid with standard ammonia.

Titration (1).....	cc. $\text{NH}_3$
(2) .....	cc. $\text{NH}_3$
Av. ....	cc. $\text{NH}_3$
N in 10 cc. of solution.....	mg.
Per cent N in dry salt.....	
The percentage purity of the dry salt is.....	

Does the percentage of nitrogen vary directly or inversely with the titration readings?



## PRACTICE XV

### NITRIFICATION

Bring 40 cc. of the standard ammonium sulfate solution into a 500-cc. measuring flask, add 0.3 g. of dipotassium phosphate, 0.5 g. of calcium carbonate, and about 2 g. of fresh, rich garden soil, and make up to the mark. Mix well and let settle.

Place 600 g. of clean, washed, and dried white sand in a percolator. Upon this pour 100 cc. of the above solution in such a way as to wet the whole surface of the sand. Allow to stand one hour, wash with about 500 cc. of ammonia-free water, collect the washings, and make up to exactly 500 cc. Place 250-cc. portions in Kjeldahl flasks and determine nitrogen in the usual way. Compare the amount of nitrogen found with that originally applied in the ammonium sulfate.

Titration (1).....	cc. $\text{NH}_3$
(2).....	cc. $\text{NH}_3$
Av.....	cc. $\text{NH}_3$
N found.....	mg.

Add another 100-cc. portion of ammonium sulfate solution to 600 g. of clean, washed, and dried sand held in a percolator, cover, and allow to stand in a dark place at warm room temperature for six weeks, adding water from time to time to prevent complete drying. Then wash out and determine the ammonia nitrogen as directed above.

Titration (1).....	cc. $\text{NH}_3$
(2).....	cc. $\text{NH}_3$
Av.....	cc. $\text{NH}_3$
N found.....	mg.
Per cent N nitrified.....	

What change has been brought about, and how? Why does not all of the nitrogen added appear in the second distillation? Why was the percolator kept in the dark? Why was  $\text{K}_2\text{HPO}_4$  added?  $\text{CaCO}_3$ ? garden soil? Why was the ammonium sulfate solution poured upon sand instead of being left in a flask?



## PRACTICE XVI

### THE EFFECT OF LIME UPON NITRIFICATION

Place 500 g. of a worn acid soil in a percolator. Upon this pour 100 cc. of a dilute ammonium sulfate solution (40 cc. of the standard ammonium sulfate solution plus 460 cc. of water). Allow to stand one hour, wash with about 500 cc. of ammonia-free water, and determine the total nitrogen<sup>1</sup> as directed in 3, Practice XXIV.

Titrations (1).....	cc. NH <sub>3</sub>
(2).....	cc. NH <sub>3</sub>
Av.....	cc. NH <sub>3</sub>
N found.....	mg.

Into one percolator bring a second 500 g. of the worn acid soil, and into another a third with which 5 g. of finely ground limestone has been thoroughly mixed. To each of these add 100 cc. of the ammonium sulfate solution used above, and allow to stand in a dark place at room temperature for six weeks. Then wash out and determine the total nitrogen as directed above.

	<i>Without lime- stone</i>	<i>With lime- stone</i>	
Titrations (1) .....	.....	.....	cc. NH <sub>3</sub>
(2) .....	.....	.....	cc. NH <sub>3</sub>
Av. ....	.....	.....	cc. NH <sub>3</sub>
N found .....	.....	.....	mg.
Per cent N nitrified.....			

Explain the effect of the limestone.

What is one effect of liming worn lands?

Does nitrification enrich the soil?

<sup>1</sup> See "Soil Fertility and Permanent Agriculture," pp. 562-563.



## PRACTICE XVII

### PREPARATION OF AMMONIUM MOLYBDATE SOLUTION<sup>1</sup>

Dissolve 100 g. of molybdic acid in 400 cc. of ammonium hydroxid of .96 specific gravity, and pour this solution slowly and with constant stirring into 1250 cc. of nitric acid of 1.20 specific gravity. It is best to cool the acid after the addition of each small amount of ammonium hydroxid. Keep the mixture in a warm place several days, or until a portion heated to 40° deposits no yellow precipitate of ammonium phosphomolybdate.

## PRACTICE XVIII

### PREPARATION OF A STANDARD POTASSIUM HYDROXID SOLUTION<sup>1</sup>

In 400 cc. distilled water dissolve the number of grams of the purest potassium hydroxid to be obtained, sufficient to make 4 liters of a solution, 1 cc. of which will be equivalent to 0.5 mg. of phosphorus. Remove carbonates with barium hydroxid, as in Practice VIII. Then make up to 500 cc. and titrate two 10-cc. portions with standard hydrochloric acid, using phenolphthalein as indicator. Compute the exact weight of potassium hydroxid in the remaining solution, and dilute with a sufficient quantity of water to reduce the strength to exactly 2.0809 g. potassium hydroxid per 100 cc., so that 1 cc. is equivalent to 0.5 mg. phosphorus.

Mix well, check up by again titrating, and label: Standard Potassium Hydroxid (1 cc. = 0.5 mg. P).

<sup>1</sup> To be done by the instructor.



## PRACTICE XIX

### PREPARATION OF A STANDARD NITRIC ACID SOLUTION<sup>1</sup>

Determine the specific gravity of concentrated nitric acid. By the use of the specific-gravity table calculate the quantity sufficient to make 4 liters of solution of the strength equivalent per cubic centimeter to the standard potassium hydroxid solution. Dilute this with ammonia-free water to 3.5 liters and titrate two 25-cc. portions of the standard potassium hydroxid with the dilute nitric acid, using phenolphthalein as indicator. Then add sufficient ammonia-free water to make the nitric acid of the same titrating strength as the standard alkali. Mix thoroughly and check by another titration.

<sup>1</sup> To be done by the instructor.

## PRACTICE XX

### DETERMINATION OF PHOSPHORUS IN FARM PRODUCE

Each group of students will work upon one of the following products :

- |                 |                    |
|-----------------|--------------------|
| 1. Wheat.       | 5. Oats.           |
| 2. Corn.        | 6. Oat straw.      |
| 3. Corn stover. | 7. Red-clover hay. |
| 4. Corncobs.    | 8. Alfalfa hay.    |

Weigh out 2 g. of the material in a 25-cc. crucible, moisten with a 15 per cent solution of calcium nitrate, dry carefully, and ignite in a muffle furnace at a low red heat for two hours. Transfer to a 250-cc. beaker, digest in about 15 cc. of nitric acid, dilute to about 40 cc., filter, and wash. Evaporate the filtrate and washings to about 25 cc., add 5 cc. of nitric acid, just neutralize with ammonia, and clear up with a few drops of nitric acid, using heat if necessary, but avoiding more than a few drops in excess. Heat to 50°-60° on a water bath, add 10 cc. of the clear molybdate solution, stir, keep at 50°-60° for one hour, and allow to stand over night. Filter, wash twice by decantation, using 25-cc. portions of cold water, stirring thoroughly, and then allowing the precipitate to settle before decanting upon a 9-cm. filter. Transfer the precipitate to the filter, and wash the beaker and filter seven or eight times with small amounts of cold water until free from acid. Place the filter containing the precipitate in the beaker and add standard potassium hydroxid in 10-cc. portions until the precipitate is dissolved. Titrate the excess alkali with standard nitric acid, using phenolphthalein as an indicator.

cc. HNO <sub>3</sub> used	cc. KOH to dissolve ppt.	mg. P	Per Cent P
.....	.....	.....	.....
.....	.....	.....	.....
Av. ....	.....	.....	.....

Calculate the results obtained, and record with these the results obtained by three members of each group as indicated on the following page. Value phosphorus at 12 cents per pound.

How many pounds of steamed bone meal will be required to replace the phosphorus removed from the soil in a 100-bushel crop of corn, a 100-bushel crop of oats, a 4-ton crop of clover hay, and a 50-bushel crop of wheat? (See Practice V.)



## PRACTICE XXI

### DETERMINATION OF TOTAL PHOSPHORUS IN SOILS

Each group of students will work upon one stock soil, such as the following:

- |                                |                                |
|--------------------------------|--------------------------------|
| 1. Surface of gray silt loam.  | 5. Surface of black clay loam. |
| 2. Subsoil of gray silt loam.  | 6. Subsoil of black clay loam. |
| 3. Surface of brown silt loam. | 7. Sandy soil.                 |
| 4. Subsoil of brown silt loam. | 8. Peaty soil.                 |

Weigh 10 g. of sodium peroxid into a crucible of spun iron or of porcelain of about 100-cc. capacity and thoroughly mix with it 5 g. of soil. If the soil is peaty, burn off the greater part of the organic matter before mixing with the sodium peroxid. If the soil is very low in organic matter, add about 0.2 g. of pulverized sugar to hasten the reaction. Heat the mixture carefully by applying a flame directly upon the surface of the charge and upon the sides of the crucible until the reaction is over, and keep at a low red heat for 15 minutes. Do not allow fusion to take place. By means of a large funnel and a stream of hot water transfer the charge to a 500-cc. measuring flask. Acidify with hydrochloric acid, add several cc. of nitric acid, and boil. If the reaction has taken place properly, there will be no particles of undecomposed soil in the bottom of the flask. Let cool, make up to the mark, and shake thoroughly. Allow the silica to settle and draw off 200 cc. of the clear solution into a beaker.

Add ammonium hydroxid until almost neutral, heat to boiling, and add ammonium hydroxid slowly in slight excess. Keep boiling hot for about one minute, stir, filter through a 15-cm. filter, and wash at once with hot water until free of chlorids. Return the precipitate to the beaker by means of a stream of hot water, holding the funnel over the beaker, and dissolve in hot nitric acid, pouring the acid upon the filter to dissolve any precipitate remaining. Evaporate solution and washings to *complete* dryness on a water bath, take up with dilute nitric acid, heating if necessary, and filter out any insoluble silica. Evaporate filtrate and washings to about 25 cc. and determine phosphorus according to the directions given in Practice XX, using 15 cc. of the clear ammonium molybdate solution.

cc. HNO <sub>3</sub> used	cc. KOH to dissolve ppt.	mg. P	% P	P in 2 mil- lion of soil
.....	.....	.....	.....	.....
.....	.....	.....	.....	.....
Av. ....	.....	.....	.....	.....

With the above results record those obtained by three members of each group, as indicated upon the following page.



## PRACTICE XXII

### SOIL ANALYSIS. DETERMINATION OF TOTAL PLANT FOOD

Each student will select a soil in which he is especially interested.<sup>1</sup>

#### 1. *Dry Matter.*

Weigh out 5 g. of the air-dried soil in a small porcelain dish, dry at 100° for five hours, cool in a desiccator, and weigh.

Weight of vessel plus dry matter	.....	.....
Weight of vessel	.....	.....
Weight of dry matter	.....	.....
Per cent of dry matter	.....	.....
Av. per cent	.....	.....

#### 2. *Nitrogen.*

Determine according to directions given in Practice IV.<sup>2</sup>

Titrations (1).....	.....	cc. NH <sub>3</sub>
(2).....	.....	cc. NH <sub>3</sub>
Av.....	.....	cc. NH <sub>3</sub>
Per cent N.....	.....	
N in 2 million of soil.....	.....	

<sup>1</sup> *Collecting Soil Samples.* After one has become familiar with the typical boring of the soil type, the sample is collected by taking borings from 10 to 20 different places, a rod or more apart, each of which should appear to be truly representative of the soil type. These borings, thoroughly mixed, should make a trustworthy sample for analysis. An auger about 1½ inches in diameter, with the screw point and the vertical lips filed off, is the most satisfactory instrument to use. The stem may be cut in two and a steel rod of good quality welded to make the auger about 40 inches long.

Ordinarily, samples may well be taken in sets of three: the surface, or average plowed soil (0 to 6½ inches); the subsurface, or that which can possibly be moved with a subsoil plow (6½ to 20 inches); and the subsoil (20 to 40 inches), corresponding to about two million, four million, and six million pounds, respectively, of ordinary soil per acre. The surface boring is made and the hole enlarged about ½ inch in diameter, the soil all being saved. The subsurface boring is then taken and the hole again enlarged, but the extra soil is not saved. Finally, the subsoil boring is taken and the soil saved from only one half (one groove) of the auger. This provides about equal quantities of soil from each stratum.

*Preparation of Sample.* The sample of soil after air drying is pulverized to pass through a sieve with round holes 1 mm. in diameter. Any gravel which does not pulverize as easily as the dried lumps of clay is weighed and its percentage determined, after which it is discarded. After thorough mixing, the sample is then placed in a tight jar and labeled for analysis.

<sup>2</sup> If for any reason it is thought that the soil contains unusual amounts of nitrates, the modified method given in Practice XXIV may be used.

PRACTICE XXII (CONTINUED)

3. *Total Phosphorus.*

Determine as directed in Practice XXI, reserving the filtrate from the ammonium hydroxid precipitate for the calcium and magnesium determinations.

cc. HNO <sub>3</sub> used	cc. KOH to dissolve ppt.	mg. P	% P	P in 2 million of soil
.....	.....	.....	.....	.....
.....	.....	.....	.....	.....
Av. ....	.....	.....	.....	.....

4. *Total Calcium.*

Concentrate the filtrate and washings from the ammonium hydroxid precipitate in 3 to about 50 cc. If upon adding a few drops of ammonium hydroxid a precipitate of aluminum appears, filter, wash, and again concentrate to about 50 cc. Add a few drops of ammonium hydroxid and enough ammonium oxalate solution to precipitate all the calcium and to transform the magnesium from chlorid into oxalate. Digest two hours on the water bath, filter, wash with hot water until free of chlorids, dry, and ignite in a weighed crucible over a Bunsen burner, finishing to a constant weight over the blast lamp.

Weight of crucible + CaO	.....	.....
Weight of crucible	.....	.....
Weight of CaO	.....	.....
Weight of Ca	.....	.....
Per cent Ca	.....	.....
Av. per cent	.....	.....
Ca in 2 million of soil	.....	.....

5. *Total Magnesium.*

Concentrate the filtrate and washings from 4 to about 50 cc., cool, add a few drops of ammonium hydroxid, precipitate the magnesium by adding slowly, while stirring, microcosmic salt in excess, add 10 cc. of ammonium hydroxid, cover, and let stand over night. Filter, wash with dilute ammonium hydroxid (1 part of ammonium hydroxid of .96 sp. gr. to 4 parts of water), dry, and ignite in a weighed crucible over a Bunsen burner, finishing to a constant weight over the blast lamp.

Weight of crucible + Mg <sub>2</sub> P <sub>2</sub> O <sub>7</sub>	.....	.....
Weight of crucible	.....	.....
Weight of Mg <sub>2</sub> P <sub>2</sub> O <sub>7</sub>	.....	.....
Weight of Mg	.....	.....
Per cent of Mg	.....	.....
Av. per cent	.....	.....
Mg in 2 million of soil	.....	.....

PRACTICE XXII (CONTINUED)

6. *Total Potassium.*

Fuse 1 g. of soil with 1 g. of ammonium chlorid and 8 g. of calcium carbonate in a platinum crucible<sup>1</sup> according to the method of J. Lawrence Smith.<sup>2</sup> Transfer the fused mass to a porcelain dish, slack with hot water, grind finely with an agate pestle, transfer to a filter, and wash with about 400 cc. of hot water. Concentrate the filtrate and washings in a Jena-glass beaker to 10 or 20 cc. on the water bath, filter, and wash. Acidify filtrate and washings with hydrochloric acid, concentrate to about 10 cc., and add 1.5 cc. of a platinic chlorid solution, of which 10 cc. contains 1 g. platinum. Evaporate on the water bath to a sirupy consistency, cool, take up with about 10 cc. of 80 per cent alcohol, filter, wash ten or twelve times with 80 per cent alcohol, three times with a solution of ammonium chlorid (200 g. ammonium chlorid in 1000 cc. of water saturated with potassium platinic chlorid), and again ten times with 80 per cent alcohol. Allow the filter to dry thoroughly, and dissolve the potassium platinic chlorid in hot water, catching the solution and washings in a weighed porcelain or platinum dish. Evaporate to dryness on the water bath, heat thirty minutes at 110° in an air bath, cool in a desiccator, and weigh.

Weight of dish + $K_2PtCl_6$	.....	.....
Weight of dish	.....	.....
Weight of $K_2PtCl_6$	.....	.....
Weight of K	.....	.....
Per cent of K	.....	.....
Av. per cent	.....	.....
K in 2 million of soil	.....	.....

<sup>1</sup> The fusion may be made in the iron crucible used for the phosphorus determination. Because of the high temperature necessary, however, but four or five determinations can be made in the one crucible.

<sup>2</sup> Fresenius's "Quantitative Chemical Analysis," 1904, p. 1175.



PRACTICE XXII (CONTINUED)

7. *Reaction.*

Follow the directions given in Practice VII.

If acid, determine the acidity according to Practice IX.

Titration (1).....	cc. NaOH
(2).....	cc. NaOH
Av.....	cc. NaOH
Per cent CaCO <sub>3</sub> required.....	
CaCO <sub>3</sub> required for 2 million of soil.....	

If alkaline, determine the inorganic carbon (limestone present), as indicated in Practice X.

cc. CO <sub>2</sub> .....		
Bar., Temp. ....		
Weight of C equivalent.....		
Weight of CaCO <sub>3</sub> equivalent.....		
Per cent of CaCO <sub>3</sub> present.....		
Av. per cent.....		
CaCO <sub>3</sub> in 2 million of soil.....		

COMPOSITION OF SOIL

	<i>Pounds per Acre</i>	
	Air-dry basis	Water-free basis
Nitrogen.....		
Phosphorus.....		
Potassium.....		
Calcium.....		
Magnesium.....		
Limestone present.....		
Limestone required.....		

Suggest a practical method, of unlimited application, by which the productive capacity of this soil may be profitably increased and permanently maintained.

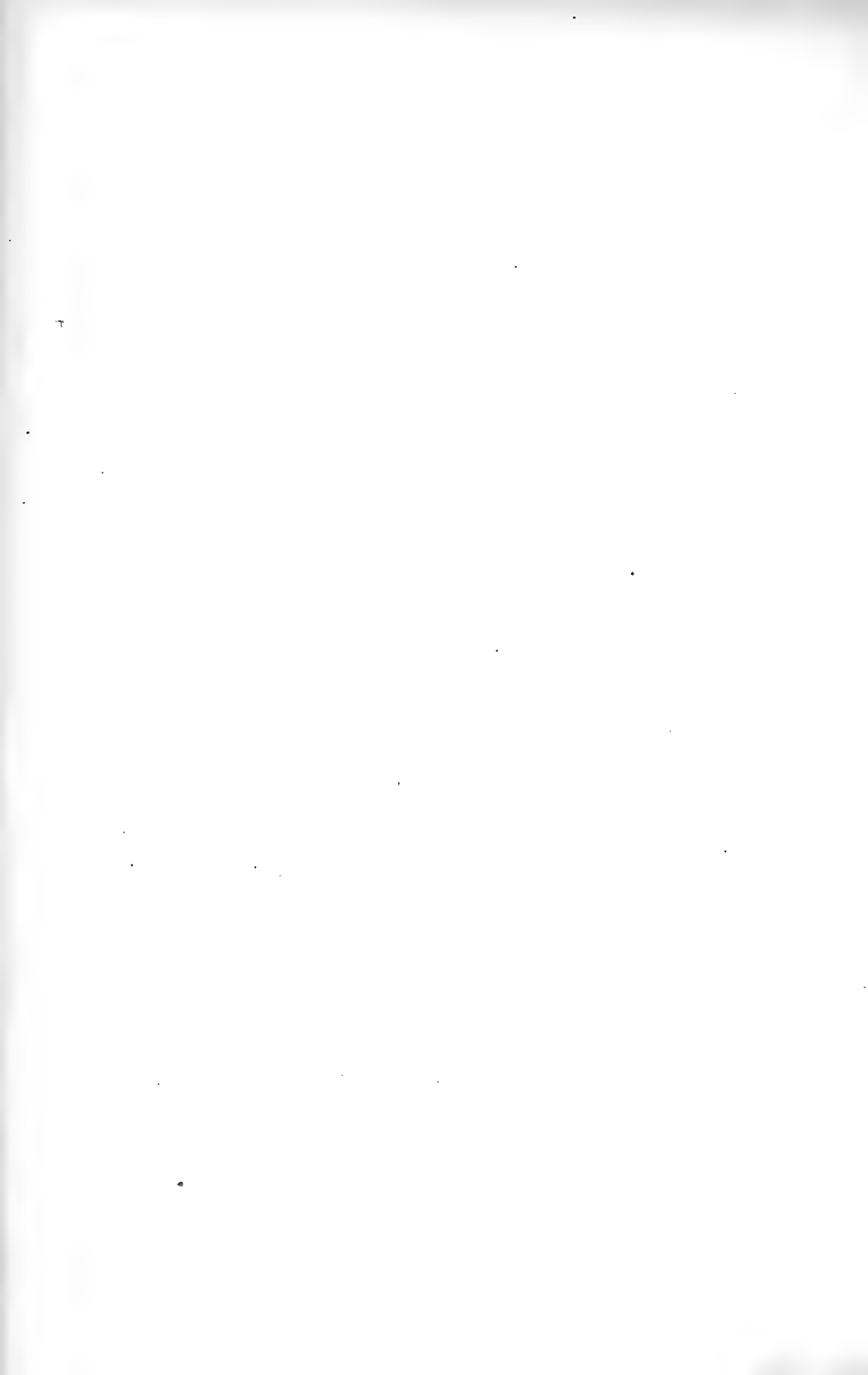



## PRACTICE XXIII

### DETERMINATION OF NITROGEN IN ANIMAL EXCREMENTS,— SOLID AND LIQUID

Each group of students will work upon one of the following:<sup>1</sup>

- |                      |   |
|----------------------|---|
| 1. Horse excrements. | 6. Poultry excrement and fresh cow's milk.      |
| 2. Steer excrements. | 7. Human excrements.                            |
| 3. Cow excrements.   | 8. Wheat straw and manger refuse (for bedding). |
| 4. Sheep excrements. |   |
| 5. Swine excrements. |   |

Record age and condition of animals and food rations as nearly as possible in all cases.

*For solid excrement:* Weigh out 10 g. of fresh substance on filter paper, placed on a watch glass, and transfer both paper and excrement to a Kjeldahl flask.

*For liquid excrement:* Measure out 10 cc. and place in a Kjeldahl flask. Compute weight from specific gravity.....g.

	<i>Solid</i>	<i>Liquid</i>	
Titration (1) .....	.....	.....	cc. NH <sub>3</sub>
(2) .....	.....	.....	cc. NH <sub>3</sub>
Av. ....	.....	.....	cc. NH <sub>3</sub>
Per cent N .....	.....		

Calculate the results obtained, and with these record the results obtained by three members of each group, as indicated upon the following page. Value nitrogen at 15 cents per pound.

10 tons alfalfa hay contain.....lb. N  
 1 ton fresh cow dung contains.....lb. N

How many tons of fresh cow dung would be required to furnish nitrogen for 10 tons of alfalfa hay?

<sup>1</sup> The student is encouraged to add to the required materials some other substance which may be of possible importance in his home community, including especially any organic refuse occurring in consequential amounts.



## PRACTICE XXIV

### DETERMINATION OF NITROGEN IN FERTILIZERS

Weigh out 0.5 g. of each of the following materials and use 20 cc. of standard hydrochloric acid in the receiver.

1. Ammonium sulfate.

2. Dried blood.

3. Sodium nitrate. (Use the Kjeldahl method modified for nitrates. With the finely ground nitrate in the Kjeldahl flask mix thoroughly 2g. of salicylic acid. Add slowly, cooling if heat is evolved, 30 cc. of concentrated sulfuric acid and, gradually, about 2 g. of zinc dust; shake thoroughly, and let stand over night. Then add mercury and digest as usual. In the distillation use 1.5 times the usual amount of alkali.)

TITRATIONS CC. NH <sub>3</sub>	AVERAGE COR- RECTED	CC. NH <sub>3</sub> FROM SAMPLE	PER CENT N	VALUE PER TON (N 15 ¢ PER POUND)
1. (a) (b)				
2. (a) (b)				
3. (a) (b)				

How would the reaction of the soil be affected by the residues left by each of these materials when used to supply nitrogen for plant growth?



## PRACTICE XXV

### DETERMINATION OF TOTAL PHOSPHORUS IN FERTILIZERS

Each group of students will work upon one of the following materials:<sup>1</sup>

- |                          |                               |
|--------------------------|-------------------------------|
| 1. Bone ash.             | 5. Raw rock phosphate.        |
| 2. Raw bone meal.        | 6. Acidulated rock phosphate. |
| 3. Steamed bone meal.    | 7. Double superphosphate.     |
| 4. Acidulated bone meal. | 8. Basic slag phosphate.      |

For materials containing more than 9 per cent of phosphorus use 1 g.; for lower percentages use 2 g. Ignite in a crucible to destroy organic matter when present. Transfer to a beaker and digest in 15 cc. of dilute nitric acid, using a gentle heat. Transfer to a 250-cc. measuring flask, cool, and dilute to exactly 250 cc. Mix well, transfer to a dry bottle, and let settle. Measure 25 cc. into a beaker and determine phosphorus according to the directions given in Practice XX, using 35 cc. of the ammonium molybdate solution.

cc. HNO <sub>3</sub> used	cc. KOH to dissolve ppt.	mg. P	% P	Pounds per ton
.....	.....	.....	.....	.....
.....	.....	.....	.....	.....
Av. ....	.....	.....	.....	.....

Calculate the results obtained, and with these record the results obtained by three members of each group, as indicated in the table on the following page. Value phosphorus in 1, 5, and 8 at 3 cents; in 2 and 3 at 10 cents; and in 4, 6, and 7 at 12 cents per pound.

<sup>1</sup> In addition the student may collect and analyze a sample of some phosphatic material which may be of special interest to his home community. (Sample a ton or a carload of bone meal or phosphate when bought in the neighborhood, by taking a teaspoonful from each of 100 different places in the lot.)





## PRACTICE XXVI

### FIXATION OF BASES IN SOILS

1. Place a small bunch of glass wool in a percolator, cover with 1 cm. of clean sand, and add 100 g. of clay soil. Upon this carefully pour 250 cc. of dilute ammonium sulfate solution (50 cc. of the solution prepared in Practice XIII, plus 200 cc. of ammonia-free water). When percolation ceases, mix the percolate thoroughly and determine nitrogen in two 50-cc. portions.

Titration (1).....	cc. $\text{NH}_3$
(2).....	cc. $\text{NH}_3$
Av.....	cc. $\text{NH}_3$
N per cc. in solution used.....	mg.
N per cc. in percolate.....	mg.
Per cent N fixed by soil.....	

2. Repeat the experiment, using 200 g. of the same soil.

Titration (1).....	cc. $\text{NH}_3$
(2).....	cc. $\text{NH}_3$
Av.....	cc. $\text{NH}_3$
N per cc. in solution used.....	mg.
N per cc. in percolate.....	mg.
Per cent N fixed by soil.....	

3. Repeat the experiment, using 200 g. of sand-soil.

Titration (1).....	cc. $\text{NH}_3$
(2).....	cc. $\text{NH}_3$
Av.....	cc. $\text{NH}_3$
N per cc. in solution used.....	mg.
N per cc. in percolate.....	mg.
Per cent N fixed by soil.....	

What class of soil components bring about the fixation of bases?

Give the general reaction, and explain fully. What chemical elements that are important in soil fertility may be retained in this way?

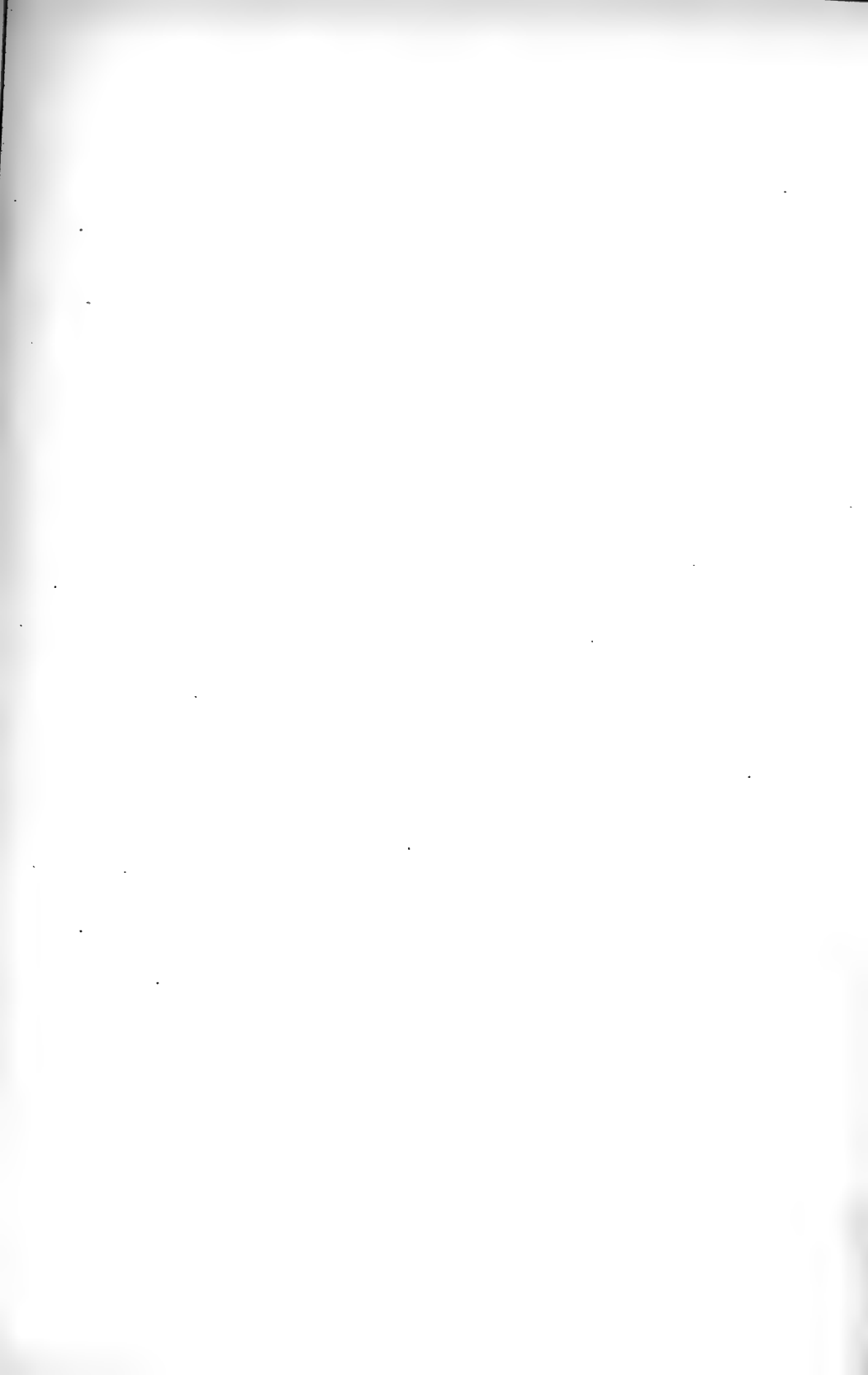

## PRACTICE XXVII

### FIXATION OF PHOSPHORUS BY SOILS

Each group of students will use one stock soil, such as the following:

- |                                |                                |
|--------------------------------|--------------------------------|
| 1. Surface of gray silt loam.  | 5. Surface of black clay loam. |
| 2. Subsoil of gray silt loam.  | 6. Subsoil of black clay loam. |
| 3. Surface of brown silt loam. | 7. Sandy soil.                 |
| 4. Subsoil of brown silt loam. | 8. Peaty soil.                 |

Dissolve 1 g. of double superphosphate in 500 cc. of water, filter, and keep in a stoppered bottle.

1. Determine the phosphorus in 50-cc. portions of this solution by concentrating to 25 cc. and following the directions given in Practice XX, but using 35 cc. of the ammonium molybdate solution.

cc. HNO <sub>3</sub> used	cc. KOH to dissolve ppt.	mg. P	mg. P per cc. of solution
.....	.....	.....	.....
.....	.....	.....	.....
Av. ....	.....	.....	.....

2. Dilute 50 cc. of the double superphosphate solution to 300 cc. and allow it to percolate through 50 g. of soil held in a percolator, as in Practice XXVI. Determine the phosphorus in 100-cc. portions of the percolate after concentrating to 25 cc., according to the directions given in Practice XX, using only 10 cc. of the ammonium molybdate solution.

cc. HNO <sub>3</sub> used	cc. KOH to dissolve ppt.	mg. P	mg. P per 6 cc. of percolate
.....	.....	.....	.....
.....	.....	.....	.....
Av. ....	.....	.....	.....
Per cent phosphorus fixed by soil.....			



PRACTICE XXVII (CONTINUED)

3. Thoroughly mix 5 g. of  $\text{CaCO}_3$  with 50 g. of the same soil, and allow a second 50-cc. portion of the double superphosphate solution, diluted to 300 cc., to percolate through the mixture. Determine the phosphorus in 100-cc. portions of the percolate, as directed above, using 5 cc. of the ammonium molybdate solution.

cc. $\text{HNO}_3$ used	cc. KOH to dissolve ppt.	mg. P	mg. P per 6 cc. of percolate
.....	.....	.....	.....
.....	.....	.....	.....
Av. ....	.....	.....	.....
Per cent phosphorus fixed by the limed soil.....			

Calculate the results obtained, and with these record the results obtained by three members of each group, as indicated in the table on the following page.

Give the general reaction for the fixation. Explain the effect of the  $\text{CaCO}_3$ . How was the fixation brought about in the noncalcareous soils? Do soluble phosphates applied on the surface penetrate deeply into the soil? How are phosphates removed from the soil largely?







## APPENDIX

The following practices are inserted by way of suggestion to students who desire to pursue the subject further, and to obtain more information in regard to their own soils. Other lines of work may be followed out at the discretion of the instructor.

Those students who are preparing to teach the subject should perform these experiments together with all of those (already given) marked "To be done by the instructor."

## PRACTICE XXVIII

### PREPARATION OF A NEUTRAL AMMONIUM CITRATE SOLUTION

To 370 g. of commercial citric acid add commercial ammonia (sp. gr. .96) until nearly neutral; reduce the specific gravity to nearly 1.09 and make exactly neutral, testing as follows: Prepare a solution of fused calcium chlorid, 200 g. to the liter, and add one fourth its volume of strong alcohol. Make the mixture exactly neutral, using a small amount of freshly prepared corallin solution as a preliminary indicator, and test finally by withdrawing a portion, diluting with an equal volume of water, and testing with cochineal solution; 50 cc. of this solution will precipitate the citric acid from 10 cc. of the citrate solution. To 10 cc. of the nearly neutral citrate solution add 50 cc. of the alcoholic calcium chlorid solution; stir well, filter at once through a folded filter, dilute with an equal volume of water, and test the reaction with a neutral solution of cochineal. If acid or alkaline, add ammonia or citric acid, as the case may be, mix, and test again, as before. Repeat this process until a neutral reaction is obtained. Add sufficient water to make the specific gravity 1.09 at 20°.

## PRACTICE XXIX

### DETERMINATION OF CITRATE INSOLUBLE PHOSPHORUS

Use the same materials and amounts as in Practice XXV. If the material is acid, wash the weighed sample on a 9-cm. filter with water until free of acid.

Heat in a water bath 100 cc. of the neutral ammonium citrate solution to 65° in a 200-cc. Erlenmeyer flask, loosely stopped with a stopper holding a 100° thermometer. When 65° is reached put in the sample and shake thoroughly. Place in the bath at 65° and let stand for thirty minutes, shaking every five minutes. At the end of thirty minutes filter and wash thoroughly with water at 65° until all soluble phosphorus is removed (test for soluble phosphorus with 1 cc. of ammonium molybdate solution). Transfer the filter and its contents to a crucible, dry, and burn off all organic matter. Transfer to a beaker, add about 15 cc. of nitric acid, and heat until all phosphorus is dissolved. Make up to 250 cc., mix well, transfer to a dry bottle, and let settle. Determine phosphorus in 25-cc. portions, according to the directions given in Practice XX.

cc. HNO <sub>3</sub> used	cc. KOH to dissolve ppt.	mg. P	% P
.....	.....	.....	.....
.....	.....	.....	.....
Av. ....	.....	.....	.....

In making any calculations, value citrate soluble phosphorus at 12 cents and citrate insoluble phosphorus at 3 cents per pound.

## PRACTICE XXX

### DETERMINATION OF ORGANIC CARBON IN SOILS

Place 2 g. of an ordinary soil (or 0.5 g. of a peaty soil), 10 g. of sodium peroxid (as free as possible from carbonate), and, depending upon the amount of organic matter present, from 0.7 to 1 g. of very finely powdered magnesium (to start the combustion) in a Parr<sup>1</sup> explosion bomb. Close the bomb, mix the contents thoroughly by shaking, place bomb in a vessel of water so that only the stem projects through a hole in the bottom of a tin can inverted over the vessel of water, and explode by means of a hot iron plug or an electric current. Bring the contents of the bomb into a beaker with a stream of hot water, boil a few minutes with the beaker covered, and, by means of the separatory funnel, bring into the Erlenmeyer flask of the apparatus. Liberate the CO<sub>2</sub> with dilute (1:2) sulfuric acid, boiling finally, measure the volume of the gas, absorb the CO<sub>2</sub> in a gas pipette containing a 33 per cent solution of potassium hydroxid, and measure the unabsorbed gas. Note the temperature and pressure, and calculate the organic carbon.

cc. of CO <sub>2</sub>	.....	.....
Bar., Temp.	.....	.....
Weight of C	.....	.....
Weight of C in peroxid	.....	.....
Weight of total C in soil	.....	.....
Per cent of total C	.....	.....
Per cent of inorganic C	.....	.....
Per cent of organic C	.....	.....

<sup>1</sup> *Journal American Chemical Society*, Vol. 26, pp. 294, 1640.

## PRACTICE XXXI

### SOIL ANALYSIS ; DETERMINATION OF THE PLANT FOOD SOLUBLE IN STRONG HYDROCHLORIC ACID<sup>1</sup>

Place 10 g. of the air-dried soil in a 200-cc. Erlenmeyer flask, add 100 cc. of hydrochloric acid (sp. gr. 1.115), close with a rubber stopper in which is a glass tube 18 inches long, and digest for ten hours on a water bath, at the temperature of boiling water, shaking once every hour. Dilute, filter through a 15-cm. filter, wash free of chlorids with hot water, and evaporate filtrate and washings to complete dryness after adding 5 cc. of nitric acid to destroy organic matter. Take up with about 10 cc. hydrochloric acid and about 25 cc. of water, heat thirty minutes, filter, and wash with hot water. Cool, make filtrate and washings up to exactly 500 cc., mix thoroughly, and put in dry stoppered bottle. Label it Solution A.

#### 1. *Phosphorus.*

Precipitate phosphorus, iron, and aluminum in 200 cc. of Solution A with ammonium hydroxid, filter, dissolve precipitate in nitric acid, and determine phosphorus in the solution as directed in Practice XX, omitting running to dryness to remove silica.

cc. HNO <sub>3</sub> used	cc. KOH to dissolve ppt.	mg. P	% P	P in 2 million of soil
.....	.....	.....	.....	.....
.....	.....	.....	.....	.....
Av. ....	.....	.....	.....	.....

<sup>1</sup> This is the official method of the Association of Official Agricultural Chemists, and is similar to the methods used in other countries.

PRACTICE XXXI (CONTINUED)

2. *Calcium and Magnesium.*

Determine these in the filtrate from the ammonium hydroxid precipitate in 1, according to the directions given in 4 and 5, Practice XXII.

Weight of crucible + CaO	.....	.....
Weight of crucible	.....	.....
Weight of CaO	.....	.....
Weight of Ca	.....	.....
Per cent of Ca	.....	.....
Av. per cent	.....	.....
Ca in 2 million of soil	.....	.....
Weight of crucible + $Mg_2P_2O_7$	.....	.....
Weight of crucible	.....	.....
Weight of $Mg_2P_2O_7$	.....	.....
Weight of Mg	.....	.....
Per cent of Mg	.....	.....
Av. per cent	.....	.....
Mg in 2 million of soil	.....	.....

3. *Potassium.*

Evaporate 100 cc. of Solution A to *complete* dryness in a porcelain dish on the water bath. Ignite gently over a Bunsen burner at a dull red heat, add a little hot water, and grind very fine with the blunt end of a glass rod. Add more water and digest thirty minutes on the water bath, filter, wash thoroughly with hot water, acidify with a few drops of hydrochloric acid, and concentrate on the water bath with 1 cc. of platinic chlorid solution to a sirupy consistency. Complete the determination as indicated in 6, Practice XXII.

Weight of dish + $K_2PtCl_6$	.....	.....
Weight of dish	.....	.....
Weight of $K_2PtCl_6$	.....	.....
Weight of K	.....	.....
Per cent of K	.....	.....
Av. per cent	.....	.....
K in 2 million of soil	.....	.....

## PRACTICE XXXII

### SOIL ANALYSIS; DETERMINATION OF THE EASILY SOLUBLE PLANT FOOD

Place 100 g. of air-dried soil in a 2-liter bottle, add 1 liter of a 1 per cent citric acid solution, let stand seven days, shaking several times each day, filter off 800 cc., evaporate to dryness finally in a small porcelain dish, gently ignite over a Bunsen burner, add 10 cc. of nitric acid, evaporate to dryness, dissolve in nitric acid, filter, and wash with hot water. Make up to exactly 500 cc., mix thoroughly, transfer to a dry bottle, and label Solution B.<sup>1</sup>

#### 1. *Phosphorus.*

Concentrate 200 cc. of Solution B to about 25 cc., and determine phosphorus according to the directions given in Practice XX, using 15 cc. of the clear ammonium molybdate solution.

cc. HNO <sub>3</sub> used	cc. KOH to dissolve ppt.	mg. P	% P	P in 2 million of soil
.....	.....	.....	.....	.....
.....	.....	.....	.....	.....
Av. ....	.....	.....	.....	.....

#### 2. *Potassium.*

Evaporate 200 cc. of Solution B to *complete* dryness and determine potassium as indicated in 3, Practice XXXI.

Weight of dish + K <sub>2</sub> PtCl <sub>6</sub>	.....	.....
Weight of dish	.....	.....
Weight of K <sub>2</sub> PtCl <sub>6</sub>	.....	.....
Weight of K	.....	.....
Per cent of K	.....	.....
Av. per cent	.....	.....
K in 2 million of soil	.....	.....

<sup>1</sup> In order to avoid any difficulty in removing the organic acid, the use of one fifth normal nitric acid, as suggested by Peters and Averitt,\* or of still weaker nitric acid, as suggested by d'Sigmond,† is to be recommended for the extraction of easily soluble plant food.

\* Bureau of Chemistry, *Bulletin 99*, p. 115; and *Bulletin 105*, p. 142.

† *Journal American Chemical Society*, Vol. 29 (1907), p. 929.

## PRACTICE XXXIII

### DETERMINATION OF THE PLANT-FOOD REQUIREMENTS OF A SOIL BY A POT-CULTURE TEST

Procure sufficient soil to fill a series of ten ordinary four-gallon butter crocks. Collect the soil to a depth of 10 inches, keeping the first five inches separate from the second five inches. Air-dry the soil and fine it so that it will pass through a  $\frac{1}{4}$ -inch mesh sieve. Separately mix the two portions very thoroughly. In the center of each pot make a drainage hole about  $\frac{1}{2}$  inch in diameter, cover this with a piece of copper-wire netting, and upon this place a bunch of glass wool extending over the hole. Fill each pot to the depth of 5 inches with an equal weight of the second depth of soil, pressing it in firmly to represent as nearly as possible natural conditions of compactness. With an equal weight for each pot of the first depth of soil, which, when thoroughly compacted, will fill the pot within  $\frac{1}{2}$  inch of the top, mix very thoroughly the kind and amount of material or materials, as indicated below, and bring the mixture into the pot.

PLAN FOR POT-CULTURE TEST

POT No.	MATERIALS TO BE APPLIED	GRAMS PER POT
1	None . . . . .	0
2	Dried blood . . . . .	15
3	Steamed bone meal . . . . .	6
4	Potassium sulfate . . . . .	3
5	None . . . . .	0
6	Blood and bone . . . . .	15 + 6
7	Blood and sulfate . . . . .	15 + 3
8	Bone and sulfate . . . . .	6 + 3
9	Blood, bone, and sulfate . . . . .	15 + 6 + 3
10	None . . . . .	0

Plant the series with wheat, oats, timothy, or other suitable crop, by removing a layer of the surface soil, distributing the seed, and returning the soil removed. A sufficient number of seeds should be planted so that a uniform number of strong seedlings may finally be left in each pot. (About 20 plants are satisfactory for cereals.) Place the series of pots either in a greenhouse or out in the open, with arrangements so that they may be protected from severe wind or heavy rain. Water as is necessary, preferably with ammonia-free distilled water or with very pure rain water.

When mature the crop should be harvested uniformly, thoroughly air-dried, and weighed, afterward separating the grain from the straw, in the case of cereals, and weighing the grain. Calculate the applications made, and the yields secured, on the acre basis.







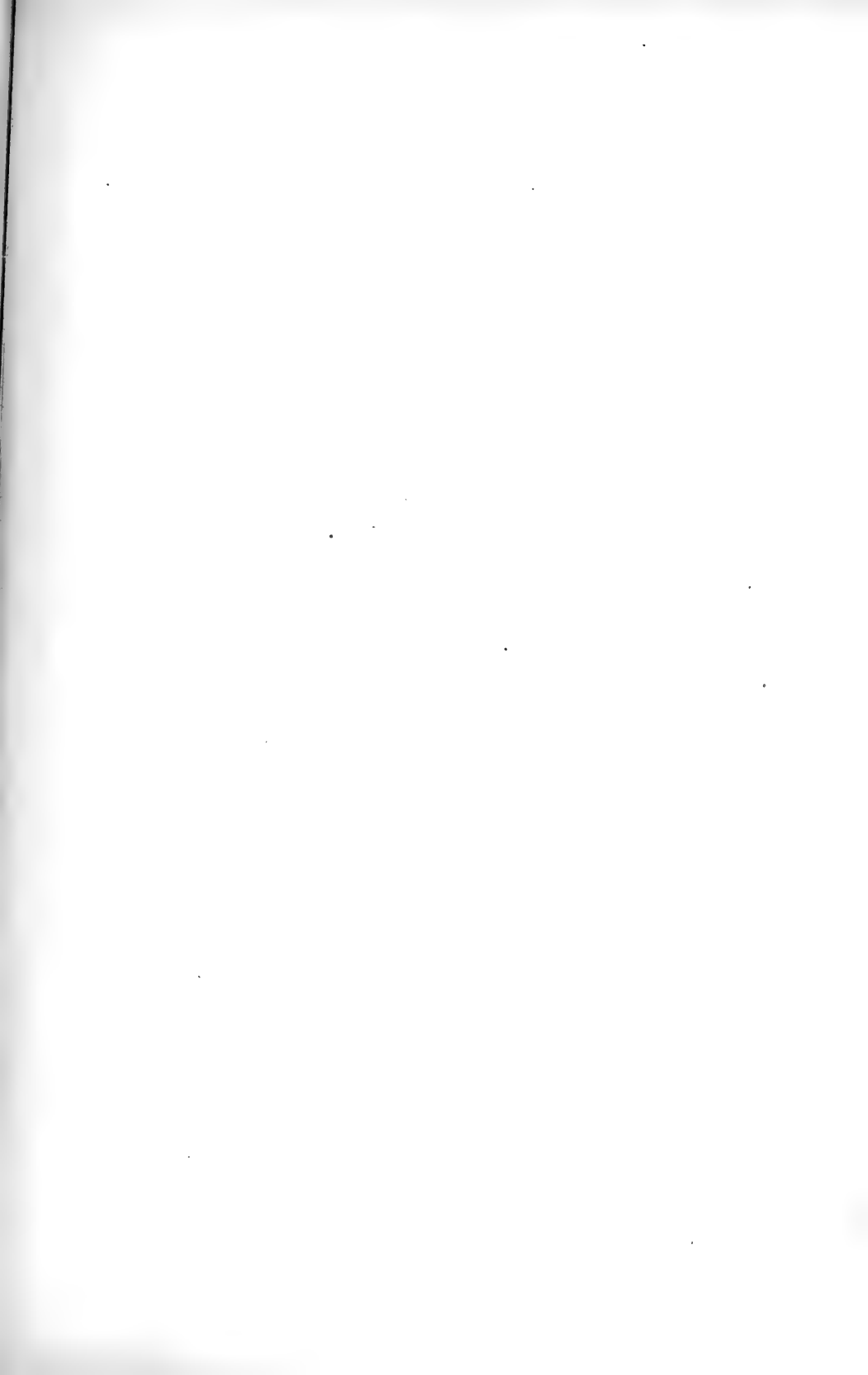



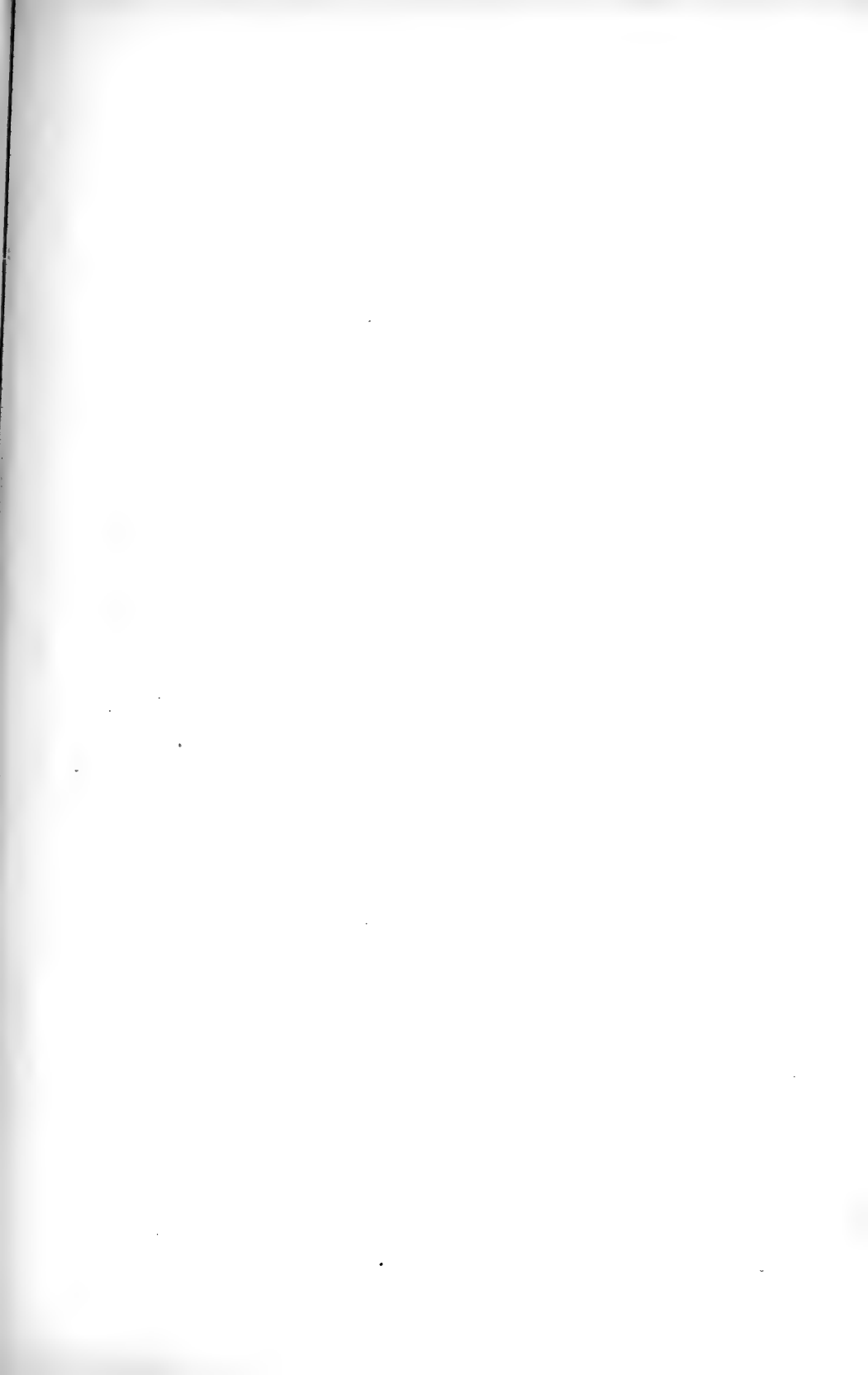













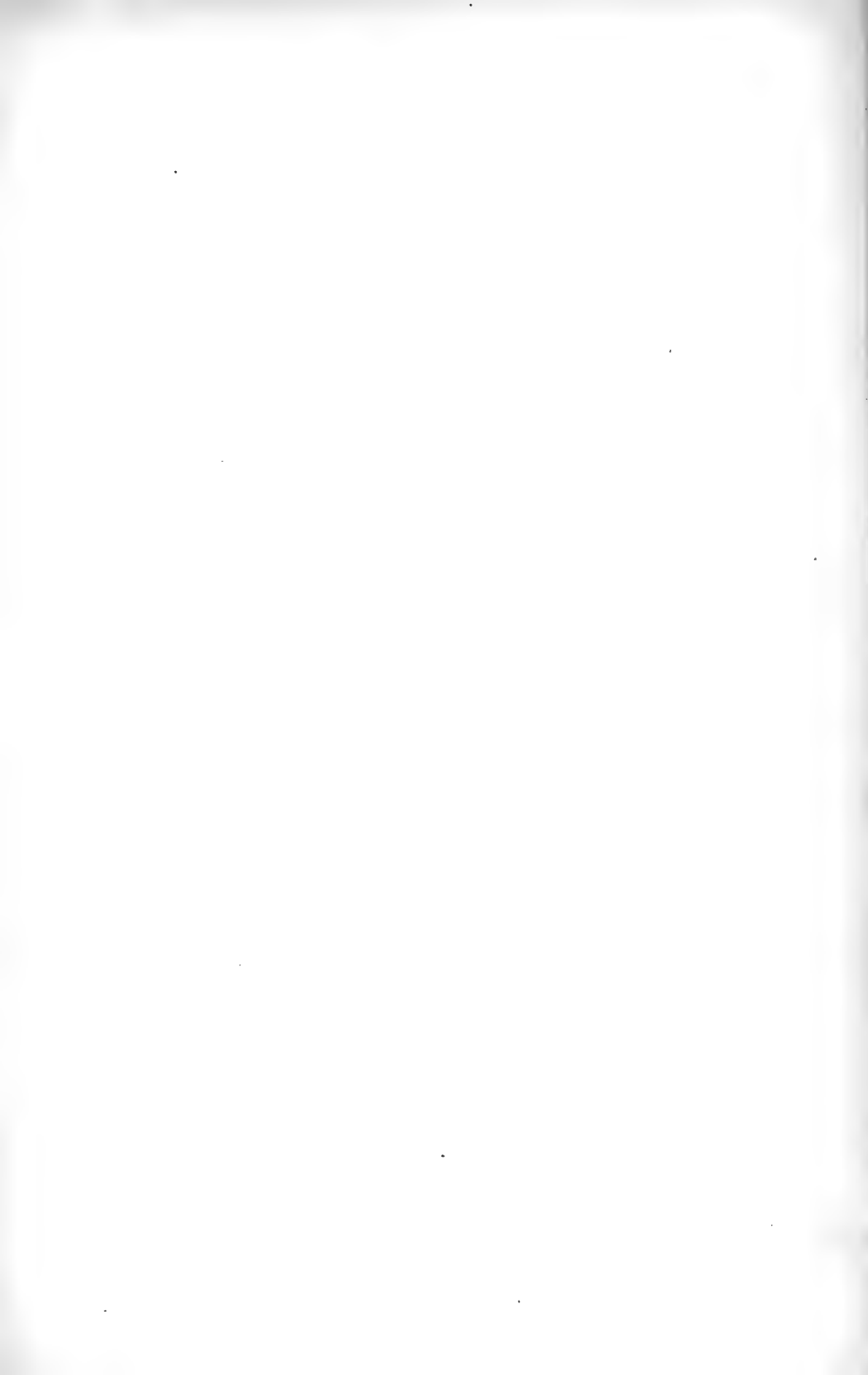



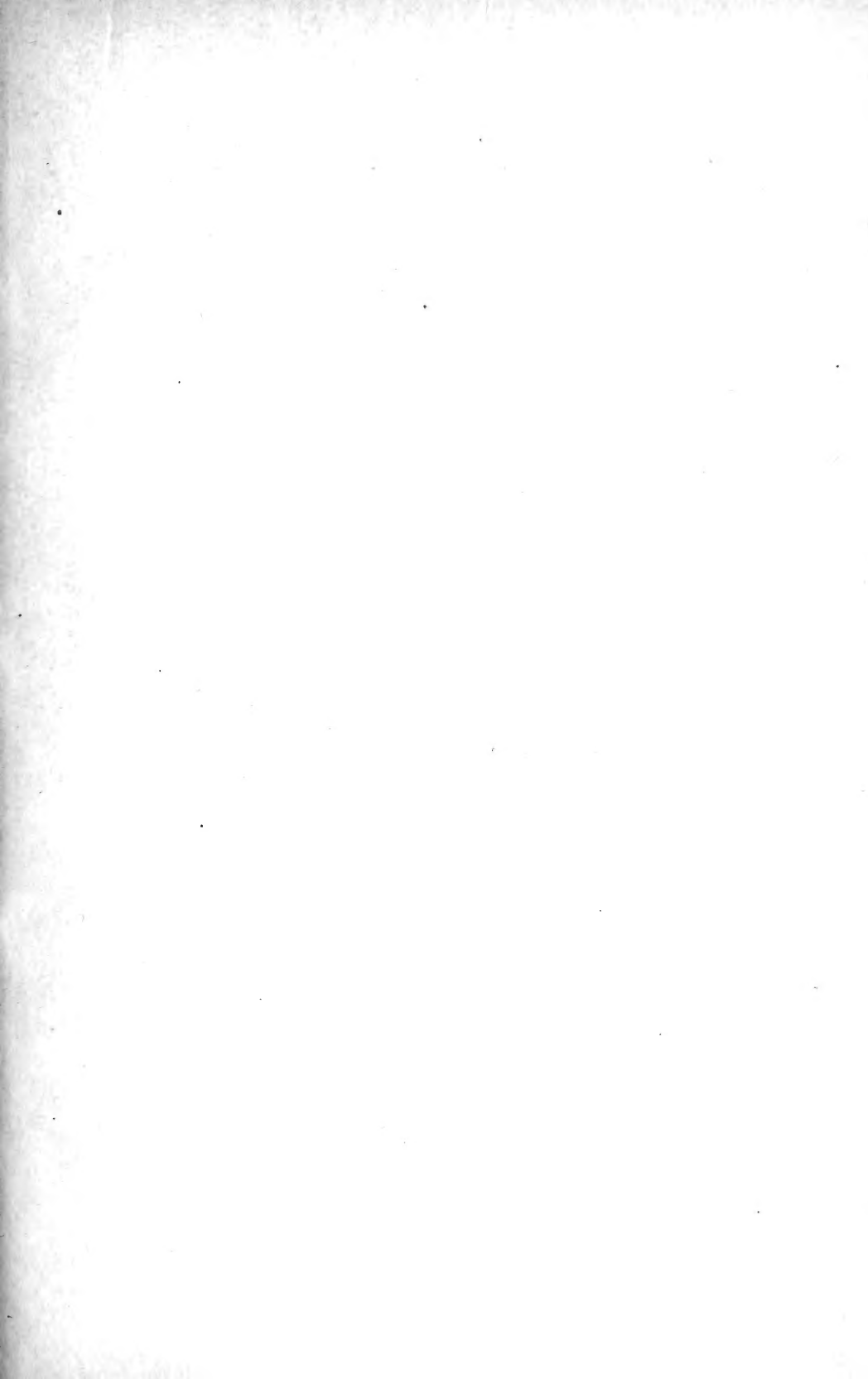



LIBRARY  
FACULTY OF FORESTRY  
UNIVERSITY OF TORONTO

S  
593  
H66

Hopkins, Cyril George  
Soil fertility laboratory  
manual

Forestry

PLEASE DO NOT REMOVE  
CARDS OR SLIPS FROM THIS POCKET

---

UNIVERSITY OF TORONTO LIBRARY

[155237]

