





**A BIOGEOGRAPHIC ANALYSIS
OF THE MAMMALS OF SALTA
PROVINCE, ARGENTINA
PATTERNS OF SPECIES
ASSEMBLAGE IN THE
NEOTROPICS**

INOCZ
LIBRARY

APR 20 1989

HARVARD
UNIVERSITY

Ricardo A. Ojeda and Michael A. Mares

SPECIAL PUBLICATIONS, THE MUSEUM
TEXAS TECH UNIVERSITY
NUMBER 27

**A BIOGEOGRAPHIC ANALYSIS
OF THE MAMMALS OF SALTA
PROVINCE, ARGENTINA
PATTERNS OF SPECIES
ASSEMBLAGE IN THE
NEOTROPICS**

Ricardo A. Ojeda and Michael A. Mares

TEXAS TECH UNIVERSITY PRESS
1989

SPECIAL PUBLICATIONS, THE MUSEUM
TEXAS TECH UNIVERSITY
No. 27

Series Editor
J. Knox Jones, Jr.

Published 29 March 1989

Copyright 1989 Texas Tech University Press

All rights reserved. No portion of this book may be reproduced in any form or by any means, including electronic storage and retrieval systems, except by explicit, prior written permission of the publisher.

Special Publications of The Museum are numbered serially and published on an irregular basis. Institutions interested in exchanging publications should address the Exchange Librarian at Texas Tech University.

ISSN 0149-1768
ISBN 0-89672-172-8

Texas Tech University Press
Lubbock, Texas

CONTENTS

INTRODUCTION.....	5
GENERAL DESCRIPTION OF THE AREA.....	9
MATERIALS AND METHODS.....	13
RESULTS.....	18
SPECIES ACCOUNTS.....	23
DIDELPHIDAE.....	24
NOCTILIONIDAE.....	24
PHYLLOSTOMIDAE.....	25
VESPERTILIONIDAE.....	26
MOLOSSIDAE.....	27
CEBIDAE.....	28
MYRMECOPHAGIDAE.....	29
DASYPODIDAE.....	29
LEPORIDAE.....	30
SCIURIDAE.....	30
MURIDAE.....	30
ERETHIZONTIDAE.....	33
CAVIIDAE.....	33
HYDROCHAERIDAE.....	34
DASYPROCTIDAE.....	34
CHINCHILLIDAE.....	34
MYOCASTORIDAE.....	35
OCTODONTIDAE.....	35
CTENOMYIDAE.....	35
ABROCOMIDAE.....	35
CANIDAE.....	35
PROCYONIDAE.....	36
MUSTELIDAE.....	36
FELIDAE.....	37
TAPIRIDAE.....	37
TAYASSUIDAE.....	38
CERVIDAE.....	38
CAMELIDAE.....	38
MAMMALIAN ASSEMBLAGES.....	39
DISCUSSION.....	47
SUMMARY.....	54
ACKNOWLEDGMENTS.....	55
GAZETTEER OF LOCALITIES.....	56
LITERATURE CITED.....	59

INTRODUCTION

Research on the structure of Neotropical mammal communities generally has been conducted in lowland tropical areas near the equator. These studies have dealt with community organization of particular taxa, mainly rodents and bats, or with the assemblage of mammals as a whole (for example, Eisenberg, 1980; Eisenberg *et al.*, 1979; Eisenberg and Thorington, 1973; Fleming, 1973; Fleming *et al.*, 1972; Humphrey *et al.*, 1983; McNab, 1971; Streilein, 1982*a*, 1982*b*; Willig, 1983).

Faunal development is becoming recognized as a complex process in the Neotropics as researchers begin to include information from the other major nontropical regions that, together with the lowland tropics, form the biogeographic mosaic of South America (Cerqueira, 1982; Crespo, 1982; Eisenberg and Redford, 1982; Koopman, 1976; Mares, 1975; Mares *et al.*, 1985*b*; Meserve and Glanz, 1978; Myers, 1982; Pearson and Pearson, 1982; Pearson and Ralph, 1978). New data on distributions and habitats of mammals are contributing to a better understanding of faunistics (Anderson *et al.*, 1982; Lucero, 1983; Mares *et al.*, 1981*a*, 1981*b*; Massoia, 1980; Olrog and Lucero, 1980; Pine *et al.*, 1979). Neotropica is the richest biotic region from the standpoint of the number of genera and species of mammals. Twelve orders, 50 families, 278 genera, and 810 species have been reported for the region (HersHKovitz, 1972). High endemism of taxa reflects the fact that South America was an island for more than 60 million years before the completion of the Panamá land bridge in the late Pliocene (Marshall, 1979; Marshall *et al.*, 1979; Raven and Axelrod, 1975; Simpson, 1978; Webb, 1978). In the Nearctic Region, 38.6 percent of the 122 genera are endemic, whereas 81.9 percent of Neotropical genera are endemic (HersHKovitz, 1958). A similar association between species richness and degree of endemism has been observed in other land masses that have been isolated for long periods (Keast, 1972). Many factors have been invoked to account for the high species richness of South America, including continental size, proximity to faunal source areas, latitude, land mass within the tropics, topographic and vegetational complexity, and Pleistocene refugia (Keast, 1972; Simpson and Haffer, 1978, and references therein).

Salta Province in northwestern Argentina (Fig. 1) is one of the most diverse regions in South America, from the standpoint of the types of major habitats it contains. Mammal investigations in northwestern Argentina have been limited mostly to natural history and basic taxonomic studies (for example, Crespo, 1964; Fornes and Massoia, 1967; Llanos, 1944; Olrog, 1958, 1959, 1976; Romaña and Abalos, 1950; Villa-R. and Cornejo, 1969; Yepes, 1944), broad faunal surveys or taxonomic treatises (for example, A. Cabrera, 1953, 1957, 1961; Cabrera and Yepes, 1960; HersHKovitz, 1962; Olrog, 1979; Pearson, 1958), and studies of specific habitats and general distribution (Mares, 1973; Mares *et al.*, 1981*a*).

In northwestern Argentina, many biotic and abiotic factors coalesce, including the interface between tropical and temperate climates and a

complex landscape with an increasing gradient in elevation from east to west. The altitude changes from 300 to almost 7000 meters above sea level within 400 kilometers. The Andes and sub-Andean and Pampean ranges create different climatic conditions, and thus many floristic communities (Cabrera, 1971). Four major vegetational regions are found in the area. Two of them, the Yungas forest and Monte Desert, reach their southern and northern limits, respectively, in Salta. The chacoan thorn scrub formation reaches its western limit in the region. The fourth vegetational region, the puna, extends both north and south of Salta. Northwestern Argentina has been defined by Hershkovitz (1958:585) as an area of transition. He noted that "... little is known of the mammals occurring along much of the boundary between Brazilian and Patagonian subregions and the dividing line on the map is largely arbitrary." According to Hershkovitz's scheme (1958, 1972), based on the distribution of extant genera, four to five districts (or faunal centers) may be present in northwestern Argentina.

Cabrera and Yepes (1960) defined six different districts contained in two main subregions (equivalent to Hershkovitz's subregions) within northwestern Argentina. In a recent review, Smith (1983*a*, 1983*b*) included Salta in a new subregion, termed the Argentine subregion, and suggested that there is no contact in northwestern Argentina with the other major subregion on the continent, defined by Smith as the Neotropical. Both are contained in the newly-termed Latin American Region. Smith's regionalization scheme was based on analyses conducted at the family level using the distribution maps of Anderson and Jones (1967). A consistent pattern found in these maps (and those of the second edition, Anderson and Jones, 1984) is that most of the tropical elements reach their southern limits along a diagonal from Perú or northern Bolivia to northeastern Argentina and Uruguay (distributional ranges of Noctilionidae, Cebidae, Myrmecophagidae, Sciuridae, Dasyproctidae, Erethizontidae, and Tapiridae, among others). This leaves northwestern Argentina in an "Argentine" subregion, when, as will be shown, populations of many tropical species extend their ranges as far south as 28° south latitude in some cases, mostly along the humid forest formation in northwestern Argentina.

A good approximation of this faunal intrusion is found in Hershkovitz (1958, 1972) for mammalian genera, and in Koopman (1976, 1982) for bats. Following Koopman's scheme of faunal provinces, the northwest is contained within both the Patagonian and Amazon Basin divisions.

Despite the various methodologies employed by these authors, and the different boundaries depicted for the major faunal subregions, their analyses convey a picture of a composite fauna inhabiting a tropical-temperate interface in northwestern Argentina. Brazilian species, Patagonian endemics, varicants, and cosmopolite taxa are part of this Neotropical biota (Hershkovitz, 1958).

Distributional boundaries of mammalian species differ as a result of complex interactions between environmental (climate, habitat type, and so

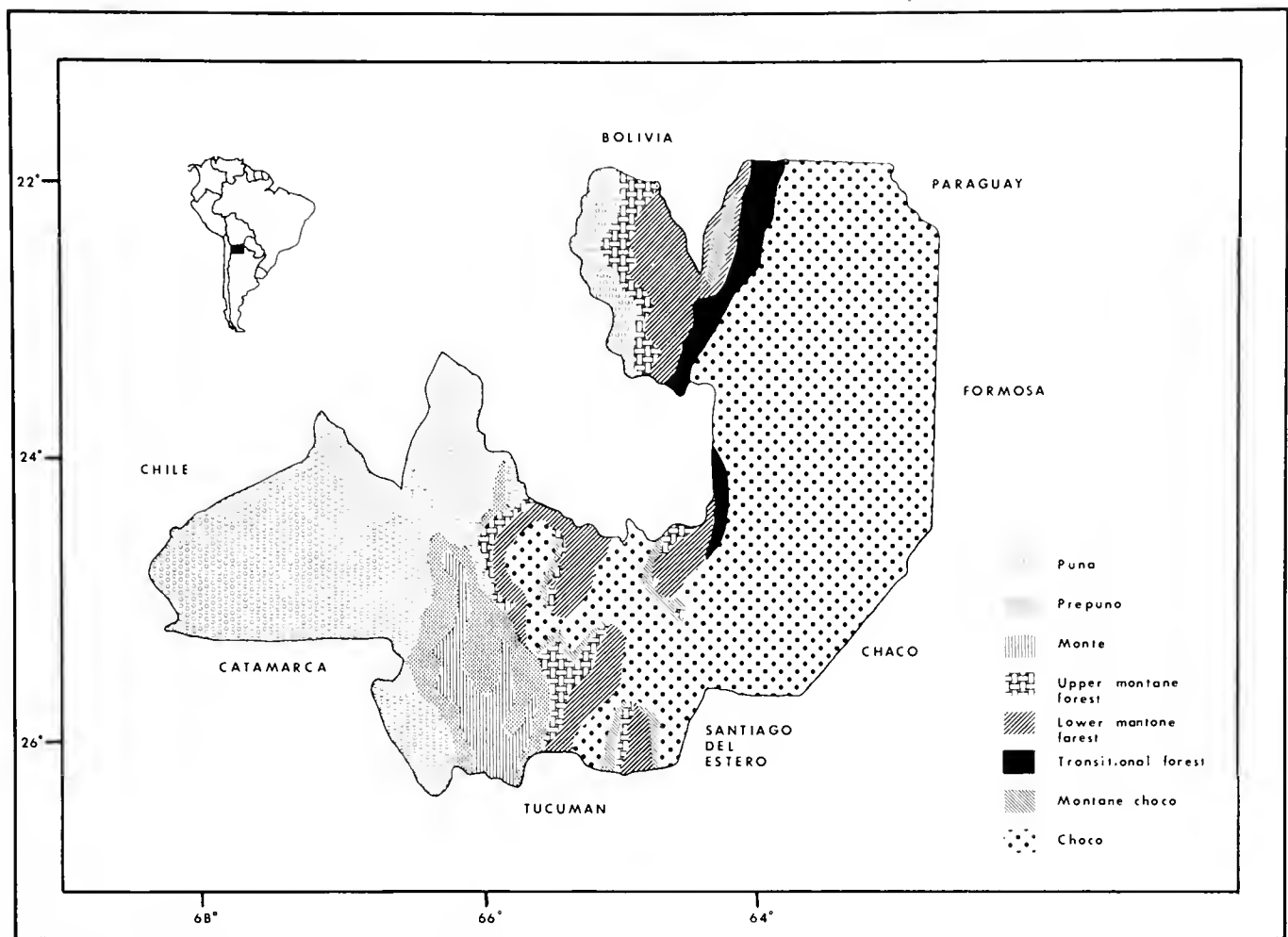

FIG. 1.—Map of Salta Province in northwestern Argentina showing its geographical location and the eight major floristic areas that occur in the province.

forth) and organismic factors (body size, trophic adaptations, density, and others) (Eisenberg, 1981). Distributional patterns of North American mammals show that the minimum size for a geographic range of a species is larger for larger mammals and that this minimum is larger for carnivores than for herbivores (Brown, 1981). On a regional scale, the numbers and kinds of species reflect the regional habitat diversity and degree of niche segregation. The structural complexity of the vegetation available in a region and long-term temporal stability may play an important role in this segregation (MacArthur, 1972; Roughgarden, 1983). Much of the South American biota evolved under conditions of isolation during a large part of its history, with the Tertiary and Quaternary being a time of great changes in climate, topography, vegetational distribution, and faunal interchange. These factors affected the species composition of the biota (Mares, 1985; Marshall, 1981; Marshall *et al.*, 1979; Patterson and Pascual, 1972; Simpson, 1979; Solbrig, 1976; Vuilleumier, 1971; Webb, 1976).

Sarmiento (1975) quantified the floristic affinities of the dry plant formations of South America and provided overall indices of similarity and relationship among different local floras on the continent. The concept of "floristic element" allows one to group species of similar origin, age, evolutionary history, or ecological requirements, and thus to separate

related groups of species that form a complex flora. This concept can be extended to faunal assemblages; this type of analysis allows a comparison of associated species that may have developed through quite different evolutionary histories (for example, see Baker and Genoways, 1978). An assessment of resemblances between the mammalian faunas of northwestern Argentina and the floristic associations described by Sarmiento (1975) suggests that similar histories and processes may have led to the development of the flora and fauna seen there today.

The identification of ecological patterns in mammalian faunas is a subject of intense research (August, 1983; Eisenberg, 1980, 1981; Eisenberg and Redford, 1982; Fleming, 1973; Grant and Birney, 1979; MacMahon, 1976; Mares, 1976; Morton, 1979; Willig, 1983; Wilson, 1973). An analysis of the mammalian occupancy of a set of macroniches has shown many resemblances between North American and temperate South American mammals (Eisenberg and Redford, 1982). The major ecological differences between these faunas result from the radiation of the edentates and hystricognaths in South America, and the extensive radiation of desert rodent granivores in North America.

In this analysis of the mammal faunas of a tropical-temperate region of northwestern Argentina, we characterize the composition and richness of faunas within eight vegetationally-defined macrohabitats. We also assess the degrees of taxonomic and ecological resemblance among the faunas and describe trends in structure and diversity of the macroniche space in this tropical-temperate interface.

GENERAL DESCRIPTION OF THE AREA

Geography

Salta Province encompasses 155,368 square kilometers (about the size of North Carolina). The eastern portion consists of a low (200 to 500 meters), flat plain with clayey soils supporting thorn scrub vegetation. Moving west, elevation increases abruptly at about 64° west longitude, where numerous north-south mountain ranges of moderate height (less than 1500 meters) form the westernmost limit of the lowlands. Between 65° and 66° west longitude, one encounters various ranges of increasing elevation (exceeding 3000 meters) having a north-south orientation. The pre-Andean mountains appear at about 66° west longitude; peaks may exceed 5500 meters. Lying to the west of these ranges is the altiplano or puna (high desert), an extensive plain found above 3400 meters elevation. The western limit of the altiplano is formed by the main Andean Cordillera, with several peaks exceeding 6000 meters elevation (Fig. 2). Information on the geography of Salta is available in A. L. Cabrera (1957, 1971, 1976) and Figueroa (1977).

Climate

There are marked climatic differences across Salta Province. The eastern lowlands (or chaco) are temperate, with hot, rainy summers and cold, dry winters. However, the climate of this area also can be considered subtropical because the mean annual temperature exceeds 21°C (Adámoli *et al.*, 1972). Daytime summer temperatures may approach 50°C, whereas winter minima are near -6°C (Fig. 3b). Rainfall varies from 500 to 800 millimeters, increasing from the eastern border of the province to the central low mountain ranges (Adámoli *et al.*, 1972; Cabrera, 1976).

A region characterized by higher temperatures and more rainfall than the chaco occurs in the transitional forest of central Salta between the easternmost low mountain ranges and the central ranges. Here, moist winds from mesic areas in Bolivia to the north and east are channeled between the low easterly ranges and the higher westerly mountains. Rainfall varies from 800 to 1000 millimeters (Adámoli *et al.*, 1972; Carlevari, 1976; DeFina, 1974) (Fig. 3a).

The third major climatic region is located along the Río Calchaquí and the pre-Andean slopes that define this extensive xeric valley. Because the high pre-Andean ranges form a barrier to the easterly flow of air, winds reaching the isolated valleys of the northern Monte Desert (Morello, 1958) are hot and dry (Fig. 3c) (Mares *et al.*, 1985a).

The last major climatic area of Salta is the vast altiplano, or puna (Fig. 3d). The climate is cold and dry, with freezing temperatures occurring over most of the year (A. L. Cabrera, 1957). Rainfall is sparse over the entire region and decreases within the province from north to south and from east to west; rainfall at the border of Salta and Chile is practically nonexistent (Cabrera, 1971).

A)

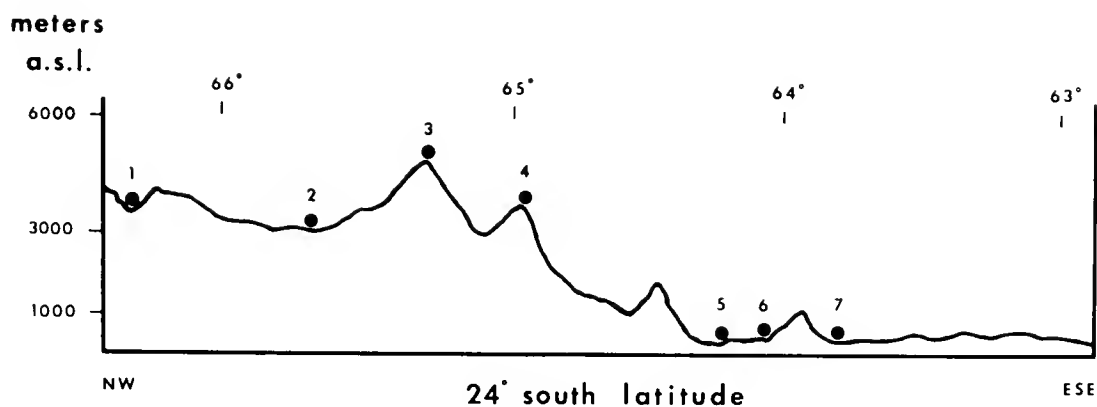

B)

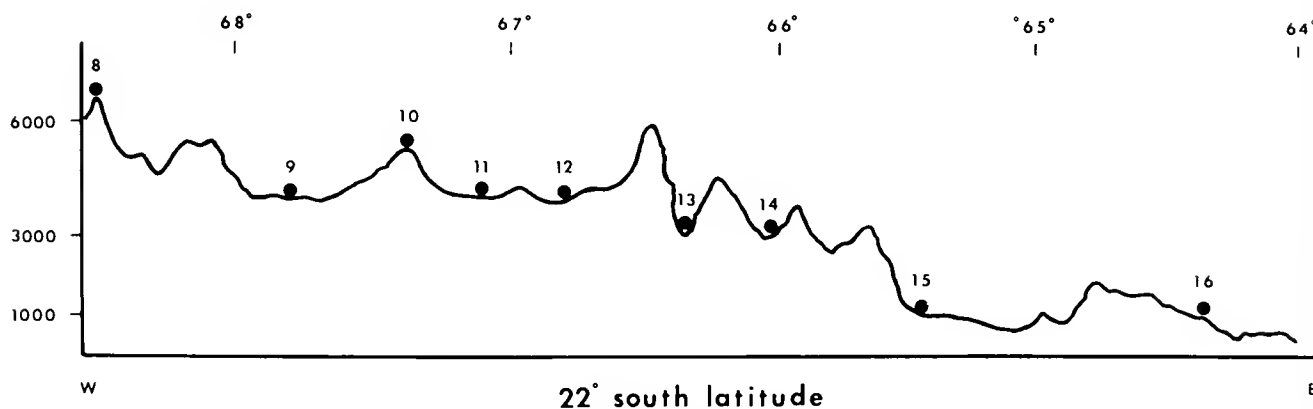

FIG. 2.—Topographic profiles of Salta Province along south latitudes 22 (A) and 24 (B). Major features include: 1) Río San Juan; 2) La Quiaca; 3) Sierra Santa Victoria; 4) Cerro Colorado; 5) Río Bermejo; 6) Río Tarija; 7) Tartagal; 8) Cerro Liullaillaco; 9) Salar de Arazaro; 10) Cordillera Calalaste; 11) Salar Pocitos; 12) Salar Pozuelo; 13) La Poma; 14) Quebrada del Toro; 15) Salta (city); 16) Sierra del Piquete. West longitudes are shown above each profile.

Vegetation

The vegetational mosaic of Salta Province is shown in Figure 1. Eight major floristic areas have been identified in northwestern Argentina (Hawkes and Hjerting, 1969; Vervoort, 1982). The most extensive plant formation is the great thorn forest, or chaco, of the eastern lowlands (Adámoli *et al.*, 1972; Morello and Adámoli, 1968; Morello and Toledo, 1959a, 1959b). The chaco is a drought-deciduous climax thorn forest consisting of spiny trees and cacti. The canopy is open and trees average eight to 16 meters in height. Due to limited topographic relief, the chaco is subject to annual flooding over extensive areas. There are a few major watercourses in the region but, because of the sporadic and intense nature of the summer precipitation, a great number of small, temporary watercourses appear across this entire area. These watercourses often persist long enough for semiriparian communities to colonize their edges.

A xerophilous forest, the montane chaco, is located in central Salta along the low mountain ranges. This forest consists of spiny trees, shrubs and cacti. Elements of the montane chaco may occur as high as 1800 meters elevation.

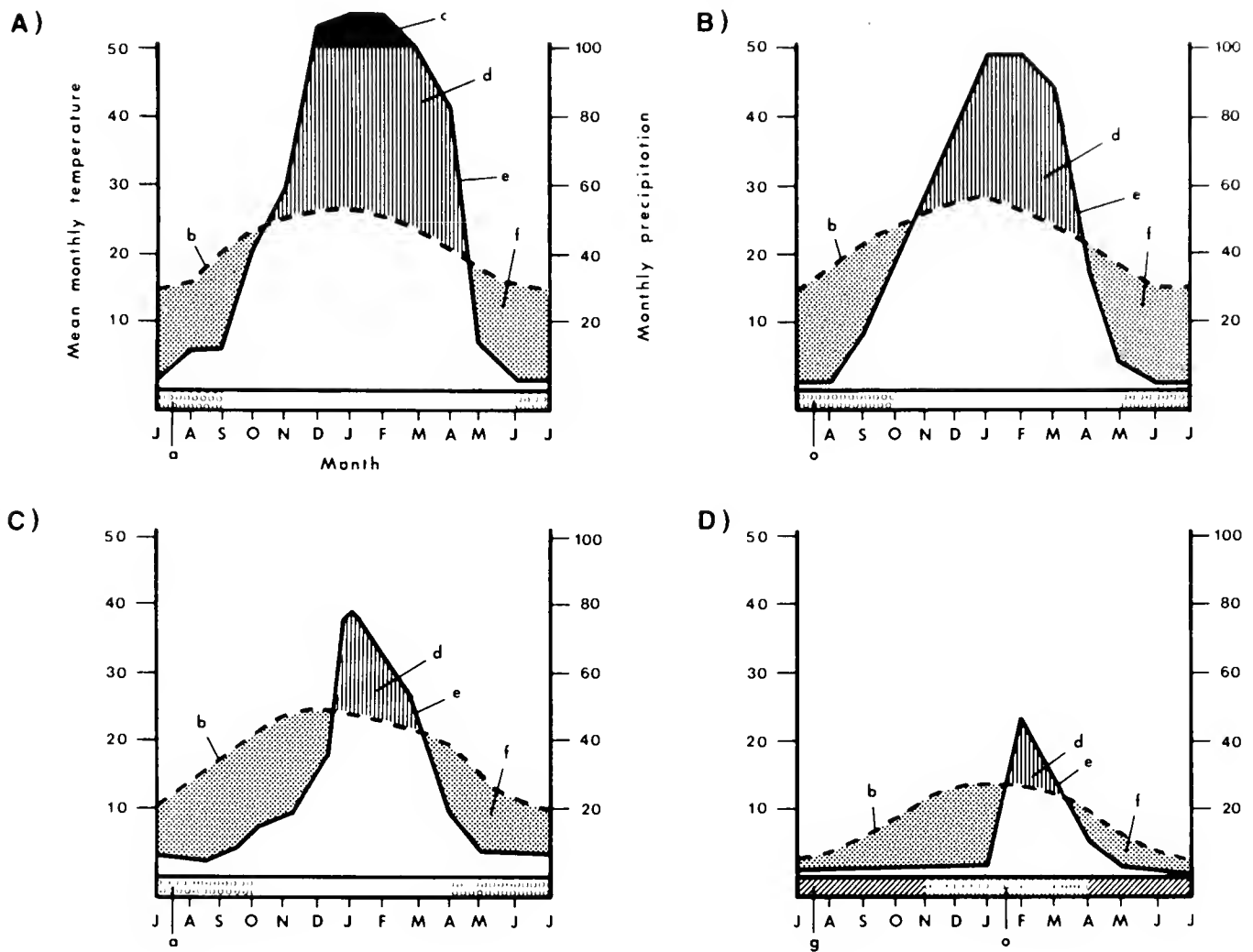

FIG. 3.—Climatograms for four areas in northwestern Argentina: A) Orán, in the transitional forest; B) Rivadavia, in the chaco; C) Andalgalá, in the monte; D) San Antonio de los Cobres, in the puna. Abbreviations: a) months with absolute minimum below 0° C; b) curve of mean monthly temperature; c) mean monthly precipitation > 100 mm. (perhumid season); d) relatively humid season; e) curve of mean monthly precipitation; f) period of relative drought; g) months with a mean daily minimum below 0° C.

Subtropical moist forest (“bosque de yungas” Cabrera, 1976), the most complex forest type found in Salta, is limited to localized moist areas of orographic rainfall. This plant formation extends along the eastern slopes of the Andes from Venezuela and reaches its southernmost limits in northwestern Argentina. It consists of a deciduous transitional forest with trees from 20 to 30 meters tall, which abuts the eastern semiarid chaco and the montane forest communities between 350 to 500 meters elevation. Annual rainfall varies from 700 to 900 millimeters.

The second vegetation type comprising the moist forest is the lower montane forest (“selva montana”) that is found between 500 to 1500 meters elevation. Trees vary from 20 to more than 30 meters in height. Shrubs, lianas, epiphytes, and grasses compose the other vegetational elements. Rainfall varies from 800 to 1200 millimeters.

The last forest type included within the moist forest is the upper montane forest (“bosques montanos”) that is found from 1500 to 2200 meters in elevation. Alder (*Alnus jorullensis*), mountain pine (*Podocarpus parlatorei*),

and queñoa (*Polylepis australis*) are the dominant trees. Above the tree line, grassland vegetation is common. This vegetation type extends southward along the mountain ranges, providing numerous islands of high altitude steppe vegetation. In the western ranges, this community is in contact with the prepuna and puna deserts, whereas in the central portion it interdigitates with the montane chaco.

The humid forest biome is only partially deciduous in the lowlands and on hillsides of medium elevation, but almost totally deciduous in the higher elevations. Because of the great amount of precipitation, the forest is quite dense with a closed canopy (in lower elevations) and epiphytes are abundant.

The arid Monte Desert reaches its northern limits between the pre-Andean ranges of western Salta in the prepuna. The prepuna vegetation ranges between 2000 and 3400 meters elevation. Vegetation on the hillsides consists primarily of columnar cacti, shrubs, and different species of bromeliads.

The monte has been extensively studied (for example, Mabry *et al.*, 1977; Morello, 1958; Orians and Solbrig, 1977; Simpson, 1977). At lower elevations, areas with ground water support mesquite forests (*Prosopis*), whereas drier sites on the mid to lower bajadas principally support creosote bush (*Larrea cuneifolia*).

The final major vegetation zone in Salta is the high Andean desert, or puna. This plain extends throughout the western third of the province above 3400 meters elevation. At lower elevations, the puna consists primarily of a shrub steppe, with bushes reaching a height of about one meter. The high-Andean zone consists primarily of a low grassland with grass clumps, low shrubs, and lichens.

MATERIALS AND METHODS

Field surveys on mammals of northwestern Argentina were conducted from 1971 to 1979 and from 1982 to 1984 within the major vegetational regions of the provinces of Salta, Jujuy, Tucumán, Santiago del Estero, Formosa, Chaco, Catamarca, La Rioja, San Juan, and Mendoza. Carnivores and large herbivores were visually recorded. Nonvolant specimens were obtained by using live traps, snap traps, and by shooting. Traps were baited with dry or moistened rolled oats or with a mixture of oats, animal fat, and peanut butter. Bats were collected by mist netting over slow-moving watercourses, over ponds, and within forested areas. Standard external measurements, sites of capture, habitat characteristics, age, and reproductive condition were recorded for specimens collected.

Specimens were prepared as museum skins and skulls or were preserved in 10 percent formalin. Specimens were deposited in the Mammal Section at the Instituto Miguel Lillo, Tucumán, Argentina, the mammal collection in IADIZA, Mendoza, Argentina, the Carnegie Museum of Natural History, Pittsburgh, Pennsylvania, and in the Museum of Southwestern Biology, University of New Mexico, Albuquerque, New Mexico.

In the analysis of distributional data, specimens and records from northwestern Argentina were examined at the following museums: (AMNH) American Museum of Natural History, New York; (IML) Instituto Miguel Lillo, Tucumán, Argentina; (MACN) Museo Argentino de Ciencias Naturales "Bernardino Rivadavia," Buenos Aires, Argentina; (BMNH) British Museum (Natural History), London; (FMNH) Field Museum of Natural History, Chicago; (RMB) collection of R. M. Barquez, Tucumán; and (CMNH) Carnegie Museum of Natural History, Pittsburgh, Pennsylvania. Additional records include reports from the technical literature. Species that may occur in the area but were not collected or recorded, as well as imported and domestic mammals, were not considered in this analysis. Specimens collected not more than 10 kilometers beyond the border of Salta were included in analyses.

Changes in the preliminary list of mammals published by Mares *et al.* (1981a) have been made. Some species listed then as probable now have been definitely included on the basis of new records. Nomenclature follows Honacki *et al.* (1982), except where noted otherwise.

A gazetteer of localities is given at the end of the text. Numbers recorded in text refer to maps of localities (Figs. 4, 5) and to localities mentioned in accounts of species. The Gazetteer no. 103 (Argentina) of the United States Board on Geographic Names prepared by the Office of Geography, Department of the Interior, Washington, D.C. (1968) was the source for coordinates of latitude and longitude; geographic coordinates (south latitude, west longitude) in degrees and minutes are given following locality designations. In order to avoid ambiguities, the names of localities have been kept, when possible, as in the original designation of museum specimens. All available records pertaining to Salta Province are listed in

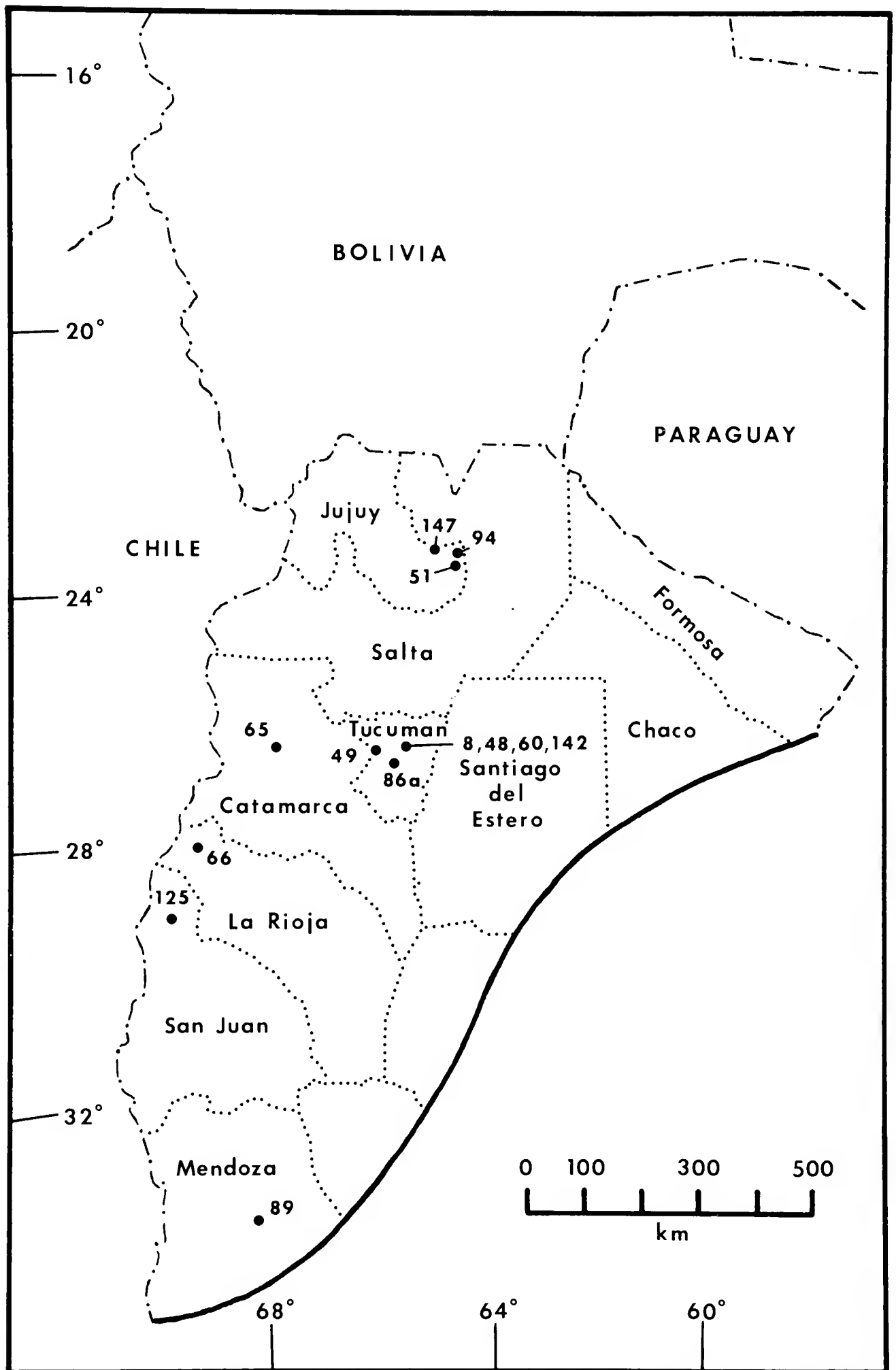

FIG. 4.—Major collecting localities in northwestern Argentina (excluding Salta Province). Numbers refer to sites listed in the gazetteer of localities.

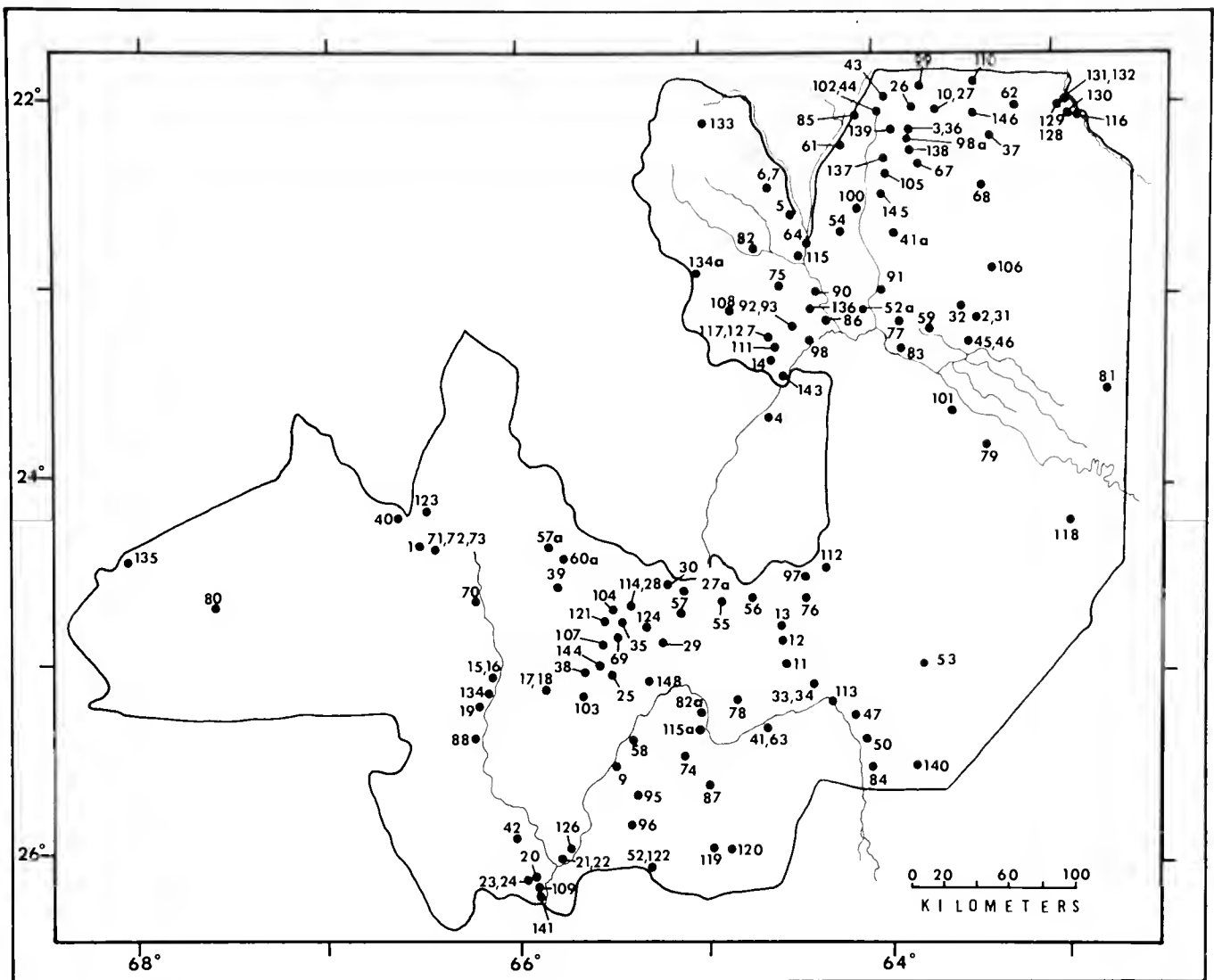

FIG. 5.—Collecting localities in Salta Province. Numbers refer to sites listed in the gazetteer of localities.

the accounts of species. Localities in the accounts of species can be located by reference to the gazetteer with the exception of Campamento, Cerro Colorado (Metán), El Desmonte, and Cueval—locations or names that were not found in available geographic references.

Locality records for each species were assigned to one of the eight floristic areas described above. The degree of interrelationship among the mammal faunas of these eight vegetational units was assessed by the Simple Matching Coefficient (S_{SM}) (Sneath and Sokal, 1973) and Sorensen's Coefficient of Community (CC) (Pielou, 1974). The simple matching coefficient is expressed as $\frac{m}{m + u}$, where m is the number of matches between each pair of floral and faunal assemblages (both presence and absence are considered equally), and u is the number of mismatches between pairs. The SIMQUAL program (NTSYS—Rohlf *et al.*, 1982) was employed in the computation of these coefficients. The OTUs (the floral areas, which are hereinafter termed macrohabitats) were then clustered according to the resemblance values of the similarity matrix and expressed as a dendrogram. Because so many investigators have drawn biogeographic insights based on analyses of association among higher taxonomic categories, such as family

or genus, we examined similarity matrices and clustered these indicators of similarity at the species, genus, and family level. We were interested in determining whether or not the taxonomic level chosen influenced the biogeographic results.

Sorensen's coefficient of community among the eight macrohabitats was determined at the generic and specific levels by: $100 \times 2a/b+c$, where a is the number of taxa (genera or species) in common to the pair of macrohabitats being compared, and b and c are the total number of elements in each macrohabitat. Sorensen's coefficient does not consider matches in negative character states (that is, joint absences).

A two-dimensional macroniche matrix (Eisenberg, 1981) was constructed on the basis of 14 feeding adaptations and eight substrate categories. Species were assigned to these 22 functional dimensions on the basis of modal strategies at the generic level, rather than the full spectrum of activities species show throughout the annual cycle of the environment (Eisenberg, 1981). Macroniche space refers to a grouping of species according to their substrate preference, mode of life, and feeding habits. Identifications of macroniches are based on our own observations as well as other sources (Anderson and Jones, 1984; Cabrera and Yepes, 1960; Crespo, 1971, 1982; Eisenberg, 1981; Eisenberg *et al.*, 1979; Eisenberg and Redford, 1982; Eisenberg and Thorington, 1973; Fleming, 1973; Glanz, 1982; Mayer and Brandt, 1982; Meserve and Glanz, 1978; Nowak and Paradiso, 1983; Wilson, 1973). For each of the eight mammal faunas, a similar matrix was constructed and species assigned to the different cells. The 22 functional dimensions used are defined below.

Substrate Categories

Fossorial.—Species that spend most of their life underground.

Semifossorial.—Species with anatomical adaptations for burrowing, but which conduct some of their activities on the surface.

Semiaquatic.—Species that perform part of their daily activities in the water.

Volant.—Species that fly.

Terrestrial.—Species that spend most of their time on the surface of the ground.

Scansorial.—Species adapted for climbing in the trees as well as living on the surface of the ground.

Arboreal.—Species that spend most of their life in trees.

Saxicolous.—Species adapted to live on rock outcroppings.

Feeding Categories

Piscivore/Crustacivore.—Species that feed mainly on fish, crustaceans, and aquatic invertebrates.

Carnivore.—Feeding on terrestrial vertebrates.

Carnivore-omnivore.—Feeding primarily on terrestrial vertebrates, but also including insects and fruits in the diet.

Nectarivore.—Species that include nectar, pollen, and fruits in the diet.

Myrmecophage.—Species that feed primarily on ants and termites.

Aerial insectivore.—Restricted to Chiroptera. Species that feed on insects in the air.

Foliage gleaning insectivore.—Feeding on insects found on foliage and on the ground.

Insectivore-omnivore.—Feeding primarily on arthropods, but also including fruits and small vertebrates in the diet.

Frugivore.—Feeding on fruits.

Frugivore-omnivore.—Species that feed on fruits, small vertebrates, and invertebrates.

Frugivore-granivore.—Feeding on fruits, nuts, and seeds.

Frugivore-herbivore.—Feeding on fruits and some leaves.

Herbivore.—Feeding on grasses, twigs, stems, and leaves.

Sanguivore.—Feeding on the blood of warm-blooded vertebrates.

Contingency tables were constructed to assess the differences between the mammal faunas in their distribution of feeding and substrate categories. The G-test was employed in the evaluation of these distributions (Sokal and Rohlf, 1969). Differences were considered significant when the probability was less than 0.05. Various categories had to be combined in some cases in order to include at least five per category, the minimum number required to perform contingency tests.

An index of macroniche diversity for each fauna was calculated using the Shannon-Wiener information index: $H' = - \sum p_i \log p_i$, where p_i is the proportion of all the species found in each macroniche cell. A measure of the species evenness among the different adaptive zones was estimated by the ratio H'/H'_{\max} . This ratio ranges from zero to one, which is to say, from a concentration of all species within one macroniche to an equitable distribution of species among all observed macroniche cells. H'_{\max} is the natural logarithm of the number of macroniches.

RESULTS

Faunal Composition

In Salta, there are 112 species in 78 genera, 28 families, and nine orders of mammals (Table 1). We examined a total of 1028 specimens from the study area. A list of 26 species, most of which have been recorded in neighboring countries or provinces and that may occur in Salta, is given in Table 2. Mammalian faunal assemblages within the region were delimited by assigning species, based on collecting records, to each macrohabitat (Fig. 1). Marked taxonomic differences ($X^2 = 6.06$; $df\ 2$; $.05 > P > .025$) at the species level were found between the two major faunas, herein defined as "aridlands" and "forests" faunas (see Mammalian Assemblages). Nine orders are found in the lower montane and transitional forests. Primates and perissodactyls are restricted to these macrohabitats. Records of primates and tapir were found for the eastern humid part of the chaco (that is, Formosa and Chaco provinces), where precipitation exceeds 1000 millimeters (compared with the dry western chaco of Salta Province with 550 millimeters of precipitation). In the eastern chaco, these animals are limited to gallery forest along the main river systems. In Salta, however, where dry chaco occurs, these species are found only in the most mesic habitats.

The only lagomorph, *Sylvilagus brasiliensis*, ranges from forests to chaco grasslands. According to Hershkovitz (1972:390), the limit of dispersion of *S. brasiliensis* in northern Argentina seems to result from competitive interactions with other leporidlike competitors such as *Dolichotis* and *Pediolagus*; however, distributional records do not support this hypothesis. Data from museum specimens show that *Pediolagus* and *Sylvilagus* coexist throughout the eastern and southeastern chaco of Argentina and Paraguay (Myers, unpublished report), although their habitats usually differ greatly. *S. brasiliensis* is found in "suitable pastoral habitats" (Hershkovitz, 1972:390), whereas *Pediolagus* inhabits the open thorn scrub forest having bare soils (see Mares *et al.*, 1981a). Moreover, *Pediolagus* is diurnal, whereas *Sylvilagus* is nocturnal. Recent habitat manipulation experiments to recover the chaco vegetation have resulted in the recolonization by *Sylvilagus* of the grassland microhabitat (C. S. Toledo, personal communication). Furthermore, the other species considered by Hershkovitz as a potential competitor, *Dolichotis patagonum*, is restricted to central, west-central, and southern Argentina (Cabrera, 1953; Mares and Ojeda, 1982; Olrog and Lucero, 1980) and does not co-occur with *Sylvilagus*.

The number of mammalian orders present in the fauna declines as aridity and altitude increase in western Salta. Above 3400 meters, five orders of mammals present in the province are absent from the puna. Rodents and carnivores are represented in all eight macrohabitats. Seven families reach their southwestern limits of distribution in Salta, mainly along the lower montane-transitional forest corridor. The families restricted to the humid forests are Cebidae, Sciuridae, Erethizontidae, Hydrochaeridae, Dasyprocti-

dae, Procyonidae, and Tapiridae. Three families (Muridae, Canidae, and Felidae) occur in all eight macrohabitats.

Octodontids, abrocomids, and camelids are restricted to the puna. These families are found in lowland habitats (for example, Patagonia, monte) as latitude increases. The only octodontid in the province of Salta, *Octodontomys gliroides*, is found at 1000 meters at about 29° south latitude and 68° west longitude in the pre-Andean ranges bordering the monte (Morello, 1958; Yepes, 1936). In La Rioja Province, guanacos were seen in the pre-Andean chains at approximately 2000 meters elevation near the locality of Jagu . Isolated populations are still found in the central monte and in ecotonal areas with the chaco in San Juan and Mendoza provinces, 600 and 900 kilometers, respectively, south of Salta. During the late Pleistocene, the guanaco extended its distribution to the undulating terrain of the pampas in Buenos Aires Province (Tonni and Politis, 1978). In recent years, its populations covered much of the lowland arid habitats of Argentina (Cajal, 1983).

At the generic level, the richest macrohabitat is the transitional forest, followed by the chaco and lower montane forest. A decrease in number of genera is observed in the upper montane forest and prepuna. The number of species present tends to increase along a gradient of increasing environmental complexity as one descends from the highland puna desert to the lowland forests (Fig. 6).

There are more volant species at lower altitudes. No bat was collected in the puna, nor were records found in collections or published reports. This absence might result from a limitation in the food supply (flying insects) at high elevations, coupled with a limited capacity to regulate body temperature at low environmental temperatures (McNab, 1983). Hershkovitz (1972) mentioned *Eptesicus fuscus* and *Histiotus macrotus* as puna elements along the altiplano of Per , Bolivia, Chile, and Argentina, although he suggested that these might be considered migrants or wind-blown waifs. Furthermore, *E. fuscus* (= *serotinus* according to Honacki *et al.*, 1982) does not extend its range farther south than middle Colombia (Koopman, 1982).

The prepuna supports only the cosmopolitan genus, *Myotis*. At a lower altitude, the northern monte has seven species of bats. A latitudinal decrease in number of bat species occurs along the 2000 kilometer length of the Monte Desert. Thus, in the intensively studied site of  acu an (central monte), 1000 kilometers south of Salta, only three species occur—*Myotis levis*, *Eptesicus furinalis*, and *Tadarida brasiliensis*. In Andalgal  and surroundings, 150 kilometers south of Salta, eight species were recorded (Mares, 1973). Most monte species belong to the families Vespertilionidae and Molossidae, with the exception of the true vampire, *Desmodus rotundus*, and a single record of *Sturnira lilium* (Phyllostomidae) (Villa-R. and Cornejo, 1969; Yepes, 1944).

The upper montane forest complex, in its grassland community (approximately 2000 to 3000 meters), shows a pattern of impoverishment

TABLE 1. List of the mammal species of Salta Province and their macrohabitat distribution.

Species	Macrohabitats							
	Puna	Prepuna	Monte	Upper montane	Lower montane	Transitional	Montane chaco	Chaco
Order MARSUPIALIA								
Family DIDELPHIDAE								
<i>Monodelphis dimidiata</i>						+		
<i>Marmosa constantiae</i>						+		
<i>Marmosa elegans</i>				+	+	+	+	+
<i>Marmosa pusilla</i>			+					+
<i>Lutreolina crassicaudata</i>					+			
<i>Didelphis albiventris</i>			+	+	+	+	+	+
Order CHIROPTERA								
Family NOCTILIONIDAE								
<i>Noctilio leporinus</i>					+	+		+
Family PHYLLOSTOMIDAE								
<i>Tonatia silvicola</i>						+		
<i>Glossophaga soricina</i>					+			
<i>Chrotopterus auritus</i>					+			
<i>Anoura caudifer</i>					+	+		
<i>Sturnira lilium</i>			+		+	+		
<i>Artibeus jamaicensis</i>					+	+		
<i>Artibeus lituratus</i>					+	+		
<i>Pygoderma bilabiatum</i>					+			
<i>Desmodus rotundus</i>			+	+	+	+		+
<i>Desmodus youngi</i>						+		
Family VESPERTILIONIDAE								
<i>Myotis levis</i>		+	+				+	+
<i>Myotis nigricans</i>						+		
<i>Myotis albescens</i>						+	+	+
<i>Eptesicus diminutus</i>						+		
<i>Eptesicus furinalis</i>					+	+		
<i>Histiotus macrotus</i>						+		
<i>Histiotus montanus</i>							+	+
<i>Lasiurus borealis</i>			+			+	+	
<i>Lasiurus cinereus</i>			+		+	+	+	
Family MOLOSSIDAE								
<i>Molossops temminckii</i>						+		+
<i>Molossops planirostris</i>						+		
<i>Tadarida brasiliensis</i>			+		+	+	+	+
<i>Nyctinomops macrotis</i>						+	+	
<i>Nyctinomops laticaudatus</i>						+		
<i>Eumops bonariensis</i>						+		+
<i>Eumops glaucinus</i>						+		
<i>Eumops perotis</i>					+		+	+
<i>Promops nasutus</i>			+					
<i>Molossus ater</i>						+		
<i>Molossus molossus</i>						+		+
Order PRIMATES								
Family CEBIDAE								
<i>Alouatta caraya</i>					+	+		
<i>Cebus apella</i>					+	+		
Order EDENTATA								
Family MYRMECOPHAGIDAE								
<i>Myrmecophaga tridactyla</i>								+
<i>Tamandua tetradactyla</i>					+	+		+
Family DASYPODIDAE								
<i>Chaetophractus vellerosus</i>	+		+			+	+	+
<i>Euphractus sexcinctus</i>						+	+	+
<i>Priodontes maximus</i>						+		+
<i>Tolypeutes matacus</i>						+	+	+
<i>Dasypus novemcinctus</i>						+		
<i>Dasypus septemcinctus</i>						+		
<i>Chlamyphorus retusus</i>								+
Order LAGOMORPHIA								
Family LEPORIDAE								
<i>Sylvilagus brasiliensis</i>					+	+		+

TABLE I.—Continued.

Species	Macrohabitats							
	Puna	Prepuna	Monte	Upper montane	Lower montane	Transitional	Montane chaco	Chaco
Order RODENTIA								
Family SCIURIDAE								
<i>Sciurus ignitus</i>				+				
Family MURIDAE								
<i>Oryzomys legatus</i>					+	+		
<i>Oryzomys longicaudatus</i>					+	+	+	+
<i>Rhipidomys leucodactylus</i>					+	+		
<i>Akodon andinus</i>	+							
<i>Akodon boliviensis</i>					+	+		
<i>Akodon varius</i>				+	+	+	+	+
<i>Akodon albiventer</i>	+							
<i>Oxymycterus paramensis</i>					+	+		
<i>Calomys laucha</i>			+				+	+
<i>Calomys callosus</i>					+	+		
<i>Eligmodontia moreni</i>			+					
<i>Eligmodontia puerulus</i>	+							
<i>Phyllotis darwini</i>	+	+	+					
<i>Auliscomys sublimis</i>		+						
<i>Graomys domorum</i>						+		
<i>Graomys griseoflavus</i>		+	+				+	+
<i>Andinomys edax</i>	+			+				
<i>Holochilus brasiliensis</i>					+	+		+
Family ERETHIZONTIDAE								
<i>Coendou prehensilis</i>						+		
Family CAVIIDAE								
<i>Microcavia australis</i>			+					+
<i>Microcavia shiptoni</i>	+							
<i>Galea musteloides</i>	+					+	+	+
<i>Pediolagus salinicola</i>								+
Family HYDROCHAERIDAE								
<i>Hydrochaeris hydrochaeris</i>					+			
Family DASYPROCTIDAE								
<i>Dasyprocta punctata</i>					+	+		
Family CHINCHILLIDAE								
<i>Lagostomus maximus</i>							+	+
<i>Lagidium viscacia</i>		+						
<i>Chinchilla brevicaudata</i>	+							
Family MYOCASTORIDAE								
<i>Myocastor coypus</i>						+		+
Family OCTODONTIDAE								
<i>Octodontomys gliroides</i>	+							
Family CTENOMYIDAE								
<i>Ctenomys frater</i>					+	+		
<i>Ctenomys mendocinus</i>								+
<i>Ctenomys opimus</i>	+							
<i>Ctenomys saltarius</i>			+					
Family ABROCOMIDAE								
<i>Abrocoma cinerea</i>	+							
Order CARNIVORA								
Family CANIDAE								
<i>Dusicyon culpaeus</i>	+	+		+				
<i>Dusicyon griseus</i>			+			+		+
<i>Dusicyon gymnocercus</i>						+	+	+
<i>Cerdocyon thous</i>					+	+	+	+
Family PROCYONIDAE								
<i>Procyon cancrivorus</i>					+	+		
<i>Nasua nasua</i>						+		
Family MUSTELIDAE								
<i>Lyncodon patagonicus</i>			+					
<i>Galictis cuja</i>			+			+	+	+
<i>Eira barbara</i>				+	+	+		
<i>Conepatus chinga</i>	+					+	+	+
<i>Lutra longicaudis</i>					+	+		

TABLE 1.—Continued.

Species	Macrohabitats							
	Puna	Prepuna	Monte	Upper montane	Lower montane	Transitional	Montane chaco	Chaco
Family FELIDAE								
<i>Felis colocolo</i>	+			+				
<i>Felis tigrina</i>						+		
<i>Felis geoffroyi</i>			+			+	+	+
<i>Felis wiedii</i>						+		
<i>Felis yagouaroundi</i>				+	+	+	+	+
<i>Felis concolor</i>	+	+	+	+		+	+	+
<i>Panthera onca</i>					+			+
Order PERISSODACTYLA								
Family TAPIRIDAE								
<i>Tapirus terrestris</i>					+	+		
Order ARTIODACTYLA								
Family TAYASSUIDAE								
<i>Tayassu tajacu</i>						+		+
<i>Catagonus wagneri</i>								+
Family CERVIDAE								
<i>Mazama americana</i>					+	+		
<i>Mazama gouazoubira</i>						+	+	+
<i>Blastoceros dichotomus</i>								+
<i>Ozotoceros bezoarticus</i>								+
Family CAMELIDAE								
<i>Lama guanicoe</i>	+							
<i>Vicugna vicugna</i>	+							

*Recently extirpated

similar to that of the pre-Andean ranges. The mammals of the alder forest community have been poorly studied, however, and it is expected that future collecting efforts will add several species to this community.

In the lower montane forest, between 800 and 1200 meters, the number of species is greater. Noctilionids (fish-eating bats) are present, and 60 percent of the bat species found in this macrohabitat are phyllostomids.

TABLE 2. List of mammal species having a high probability of being found in Salta Province, Argentina, although not recorded to date.

Order MARSUPIALIA	Family DASYPODIDAE	Family CAVIIDAE
Family DIDELPHIDAE	<i>Chaetophractus villosus</i>	<i>Cavia tschudi</i>
<i>Monodelphis kunsi</i>	<i>Cabassous chacoensis</i>	Family ERETHIZONTIDAE
Order CHIROPTEA	<i>Dasypus hybridus</i>	<i>Coendou bicolor</i>
Family NOCTILIONIDAE	Order RODENTIA	Order CARNIVORA
<i>Noctilio albiventris</i>	Family MURIDAE	Family URSIDAE
Family PHYLLOSTOMIDAE	<i>Oryzomys concolor</i>	<i>Tremarctos ornatus</i>
<i>Phyllostomus discolor</i>	<i>Akodon caenosus</i>	Family FELIDAE
<i>Sturnira erythromos</i>	<i>Akodon budini</i>	<i>Felis jacobita</i>
Family VESPERTILIONIDAE	<i>Akodon jelskii</i>	Order ARTIODACTYLA
<i>Eptesicus brasiliensis</i>	<i>Bolomys lenguarum</i>	Family TAYASSUIDAE
<i>Lasiurus ega</i>	<i>Calomys lepidus</i>	<i>Tayassu pecari</i>
Family MOLOSSIDAE	<i>Calomys musculus</i>	Family CERVIDAE
<i>Eumops abassus</i>	<i>Phyllotis osilae</i>	<i>Hippocamelus antisensis</i>
Order EDENTATA	<i>Phyllotis caprinus</i>	
Family BRADYPODIDAE	<i>Neotomys ebriosus</i>	
<i>Bradypus variegatus</i>		

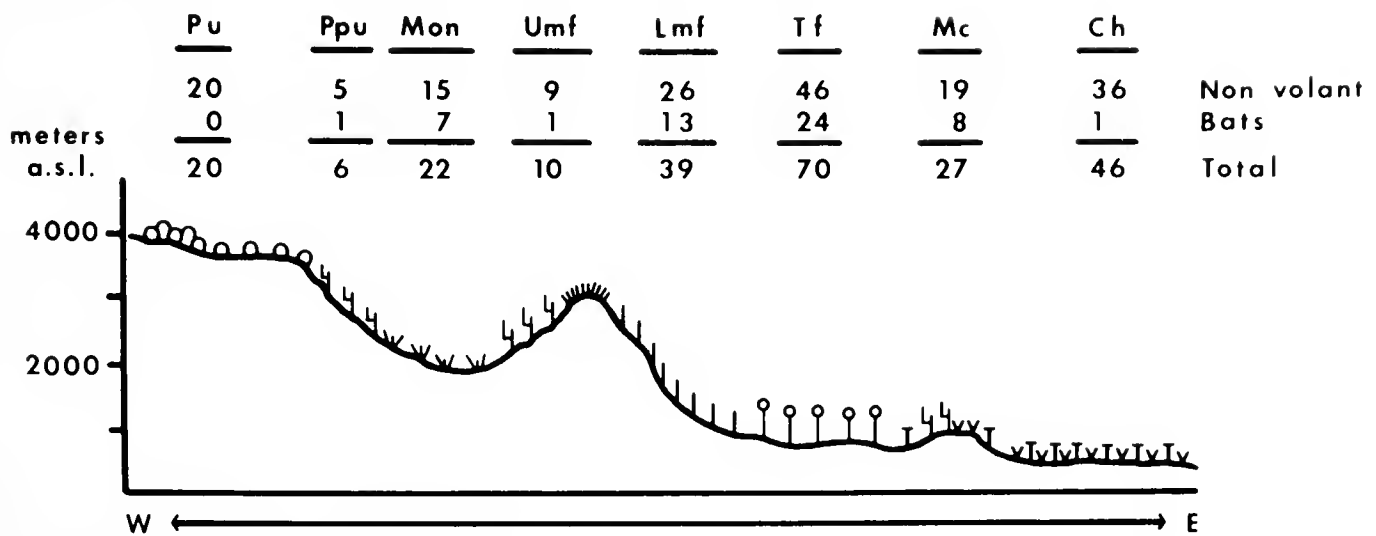

FIG. 6.—Schematic representation of volant and nonvolant species richnesses among the major macrohabitats of Salta Province along an elevational east-west gradient. Abbreviations: Pu, puna; Ppu, prepuna; Mon, monte; Umf, upper montane forest; Lmf, lower montane forest; Tf, transitional forest; Mc, montane chaco; Ch, chaco.

The richest bat assemblage is found along the foothills and plains of the transitional forest, between the lower montane forest and the chaco. Vespertilionids and molossids, insectivorous species, dominate; only 33 percent of the species belong to the family Phyllostomidae.

Most bats found in the chaco are insectivores of the families Vespertilionidae and Molossidae, although *Noctilio leporinus* and *Desmodus rotundus* both are found there. *Noctilio* disperses along the chacoan river systems (Olrog, 1976).

The nonvolant mammals show a similar trend in species density. A difference, however, is observed between the puna and monte-upper montane forest where a decline in species richness occurs. This apparent difference may result from a lack of good collecting records for the upper montane forest. As with bats, the richest macrohabitat for nonvolant species is the transitional forest.

Species Accounts

In the following section, a brief account of each species is given. Families and genera are listed phylogenetically. Within a genus, species are listed alphabetically and include the number of specimens examined in each museum. Macroniche is given only for the first species listed in each genus. Localities are quoted from the specimen labels. Not every locality is listed in the gazetteer; rather, major collecting sites, points of reference, or localities that are difficult to locate are listed. Individual collecting localities in the accounts of species can be located by reference to the sites given in the gazetteer. Localities from the literature also are noted in cases where specimens were not examined.

Order MARSUPIALIA

Family DIDELPHIDAE

Monodelphis dimidiata (Wagner, 1847)

Records of occurrence.—1 (MACN), Tartagal. *Macroniche.*—Scansorial/insectivore-omnivore (Streilein, 1982a). *Remarks.*—Crespo (1964) described this opossum from Tartagal under the name *M. fosteri*, but Reig (1964) synonymized *fosteri* with *M. dimidiata*.

Marmosa constantiae (Thomas, 1904)

Records of occurrence.—1 (IML), Orán. *Macroniche.*—Scansorial/insectivore-omnivore. *Remarks.*—The records from Orán (Olrog, 1959) and Yuto, site 147 (Thomas, 1920), are the southernmost known for this species.

Marmosa elegans (Waterhouse, 1839)

Records of occurrence.—5 (CMNH), 24 km. NW Aguas Blancas; Juntas de San Antonio; Quebrada de San Lorenzo, 12 km. NW Salta; 27 km. E Tartagal, along Tonono Rd.; 5 (IML), Aguaray, 700 m.; Playa Ancha; Santa Victoria W; Orán; 8 (MACN), Aguaray, 700 m.; Orán; Santa María W. *Remarks.*—This is a common marsupial in forested habitats of northwestern Argentina. The species was collected at sites 7, 8, 48, 51, 60, 64, 104, 138, and 142. Cajal (1981) reported on the home range and general ecology in the transitional forest of Tucumán Province.

Marmosa pusilla (Desmarest, 1804)

Records of occurrence.—3 (CMNH), 30 km. E Cachi; 5 km. S Tolloche, on Vinalito Rd.; 1 (IML), Hickman. *Remarks.*—Generally captured in rocky and grassy habitats within the semiarid chaco and monte. Individuals were collected at sites 8, 17, 89, and 140. Site 8 is in a transitional forest in Tucumán Province. *M. elegans* and *M. pusilla* coexist in this habitat (Cajal, 1981).

Lutreolina crassicaudata (Desmarest, 1804)

Records of occurrence.—2 (CMNH), 24 km. NW Aguas Blancas. *Macroniche.*—Scansorial/carnivore-omnivore. *Remarks.*—This species is restricted to forested habitats in Salta. Individuals were collected at sites 7, 8, and 60. The southern distribution of this medium-sized marsupial in northwestern Argentina reaches the lower montane forests of Tucumán Province (Olrog, 1976). Cajal (1981) reported on home range for this species.

Didelphis albiventris Lund, 1841

Records of occurrence.—1 (CMNH), 6 km. SW Santa Victoria E, at "El Breal"; 63 (MACN), Agua Linda; Aguaray; Cafayate; Cueval. Yepes (1944) reported specimens from Aguaray; Cafayate; El Quebrachal; Dragones; Lumberas; Tabacal; Zuviría. *Macroniche.*—Scansorial/insectivore-omnivore. *Remarks.*—This species occupies a wide variety of habitats in northwestern Argentina, although it does not seem to occur in the arid highland habitats. Cajal (1981) reported on home range in the transitional forest of Tucumán Province.

Order CHIROPTERA

Family NOCTILIONIDAE

Noctilio leporinus (Linnaeus, 1758)

Records of occurrence.—3 (IML), Los Madrejones; Ríos Tarija e Itaú; 1 (MACN), Orán; Hickman (Villa-R. and Cornejo, 1969). *Macroniche.*—Volant/piscivore-crustacivore. *Remarks.*—Although included within the piscivore-crustacivore category, this species is primarily a piscivore-insectivore; however, our macroniche feeding categories do not have

either a purely piscivorous or a piscivorous-insectivorous designation. The category utilized is as close as our analyses allowed for this unusual species. This bat occurs in the chacoan area of Bañado de Figueroa in Santiago del Estero Province, through the major network of rivers across eastern Salta (Olrog, 1976).

Family PHYLLOSTOMIDAE

Tonatia silvicola (D'Orbigny, 1835)

Records of occurrence.—Palma Solá, Jujuy Province (Fornes and Massoia, 1967). *Macroniche.*—Volant/foilage-gleaning insectivore. *Remarks.*—Although not cited for the province of Salta, this locality lies within 10 kilometers of the border. This is the southernmost record for the species.

Glossophaga soricina (Pallas, 1766)

Records of occurrence.—1 (IML), Quebrada de Tartagal, Finca Abra Grande. *Macroniche.*—Volant/nectarivore. *Remarks.*—Listed as probable by Mares *et al.* (1981a), the presence of this species recently has been confirmed (Barquez, 1985). This record (site 105) is the southwesternmost for this bat.

Chrotopterus auritus (Peters, 1856)

Records of occurrence.—3 (IML), 20 km. NW Aguas Blancas, Vado de Arrayazal; Establecimiento Abra Grande, 20 km. NW Orán; 1 (RMB) Dpto. San Martín, 6 km. W Piquirenda Viejo; Río Mojotoro, 5 km. N Salta; Mina Pablo, Unchimé, 25 km. E General Guemes, 1100 m. (Villa-R. and Cornejo, 1969). *Macroniche.*—Volant/carnivore. *Remarks.*—Barquez and Guerrero (1985) extended the distribution approximately 260 kilometers southward to southwestern Tucumán Province.

Anoura caudifer (É. Geoffroy St.-Hilaire, 1818)

Records of occurrence.—1 (IML), Itaú, 1600 m. *Macroniche.*—Volant/nectarivore. *Remarks.*—Olrog and Barquez (1979) and Barquez (1984a) listed the only specimen as *A. geoffroyi*, but Barquez and Olrog (1985) reported it as *A. caudifer*. Barquez (personal communication) does not believe that *A. geoffroyi* has been obtained in Argentina.

Sturnira lilium (É. Geoffroy St.-Hilaire, 1810)

Records of occurrence.—33 (CMNH), 24 km. NW Aguas Blancas; Juntas de San Antonio; 7 (IML), Aguas Blancas; 20 km. NW Aguas Blancas, Vado de Arrayazal; Juntas de Ríos Bermejo y Tarija; 2 (MACN), Aguaray; Tartagal. Yepes (1944) reported specimens from El Tabacal and Seclantás. *Macroniche.*—Volant/frugivore. *Remarks.*—This frugivorous bat is the most common phyllostomid in northwestern Argentina. Individuals were collected at sites 7, 51, 64, and 102. This species has been collected in the gallery forest of the humid eastern chaco of Argentina (Ojeda and Barquez, 1976) and boreal chaco of Paraguay (Myers, 1982). The record from Seclantás (Monte Desert—Yepes, 1944) departs considerably from the humid forests and might prove to be an uncharacteristic record. The southwestern distributional limits coincide with the distribution of humid forest to 28° south latitude.

Artibeus jamaicensis Leach, 1821

Records of occurrence.—16 (CMNH), Juntas de San Antonio; 15 km. S Orán, along Río Santa María; 22 km. SW Orán, along Río Santa María; 2 (IML), Juntas de Ríos Tarija y Bermejo. *Macroniche.*—Volant/frugivore. *Remarks.*—This is a fairly common species in Salta (Mares *et al.*, 1981a). Koopman (1982 and personal communication) considers the northwestern Argentine species to be *lituratus*. Although the *Artibeus* complex is in need of revision, the cranial differences in size and shape, less-differentiated facial stripes, and the presence of the

third upper molar agree with Davis (1970), and these bats are here placed under *A. jamaicensis* (Barquez, 1984a). A record was reported from northeastern Tucumán Province by Olrog (1976), but no specimens were found in the IML collection. In his account of the phyllostomids housed in that collection, Barquez (1984a) made no reference to specimens from Tucumán. The southernmost record of the species is in north-central Salta Province, until the record from Tucumán is confirmed. Collecting for bats at different sites in the southwestern forests of Tucumán yielded no specimens of this species.

Artibeus lituratus (Olfers, 1818)

Records of occurrence.—2 (IML), Aguas Blancas. *Remarks.*—An individual was collected along a creek in the southern locality of Aguas Chiquitas, El Cadillal, Tucumán Province. The site is a humid enclave traversed by a fast-flowing creek within the transitional forest. Meyer and Weyrauch (1966) reported this species as locally abundant in the alder forest community 93 kilometers southwest of Tucumán (city). No specimens from Tucumán Province were found in the IML collection. The report from central Tucumán Province represents the southern record of distribution of this tropical species along the forest corridor of northwestern Argentina. Barquez (1984a) reported on the morphometrics of specimens housed at the IML collection. This is one of the dominant species in the palm-savanna forest community of Bolivia (Ojeda and Barquez, 1978), 550 kilometers north of Salta Province.

Pygoderma bilabiatum (Wagner, 1843)

Records of occurrence.—1 (CMNH), 30 km. N Tartagal; 3 (IML), Aguas Blancas; 20 km. NW Aguas Blancas, Vado de Arrayazal. *Macroniche.*—Volant/frugivore. *Remarks.*—These are the southwesternmost records of this species.

Desmodus rotundus (É. Geoffroy St.-Hilaire, 1810)

Records of occurrence.—2 (IML), Quebrada de Acambuco; 5 km. W Dique Itiyuro; 13 (MACN), Santa Victoria E; 30 km. SSW General Guemes. Barquez (1984a) reported specimens from Aguas Blancas and Laguna de las Catas, Tartagal. Villa-R. and Cornejo (1969) reported specimens from: 4 km. W Cafayate, Cueva del Indio; 6 km. SSW Chicoana, 1400 m.; 15 km. SSW Santa Victoria W, 2000 m. *Macroniche.*—Volant/sanguivore.

Desmodus youngi Jentink, 1893

Records of occurrence.—1 (IML), Agua Salada, Río San Francisco, Jujuy Province (Barquez, 1984b). *Remarks.*—This is the southernmost record for the species.

Family VESPERTILIONIDAE

Myotis albescens (É. Geoffroy St.-Hilaire, 1806)

Records of occurrence.—2 (CMNH), 22 km. SW Orán, along Río Santa María; 6 km. SW Santa Victoria E, at "El Breal"; 1 (IML), Hickman, Luna Muerta. LaVal (1973) and Villa-R. and Cornejo (1969) reported specimens from: Salta, casa habitada, and La Merced, 1200 m. *Macroniche.*—Volant/aerial insectivore. *Remarks.*—Two individuals of this uncommon species were captured at site 92.

Myotis levis (É. Geoffroy St.-Hilaire, 1824)

Records of occurrence.—2 (BMNH), Valle de Lerma; Department of San Carlos (Yepes, 1944); Cafayate, Finca La Rosa, 2000 m.; Guachipas, 1500 m.; Guemes, 734 m.; La Merced, 1200 m.; Rosario de Lerma, 35 km. SW Salta, 1600 m.; Salta, Capital, 1200 m.; Valle de Lerma, 1200 m. (LaVal, 1973). Villa-R. and Cornejo (1969) also reported specimens from Cafayate and 35 km. SW Salta, Río Blanco, 1600 m., under the name of *M. chiloensis* (see LaVal, 1973, for

synonymy with *M. levis*). *Remarks*.—This species was collected at site 89 in the central Monte Desert, where it coexists with *Tadarida brasiliensis* and *Eptesicus furinalis*. Mares (1973) mentioned this species as one of the common bats in the northern monte.

Myotis nigricans (Schinz, 1821)

Records of occurrence.—1 (CMNH), 15 km. S Orán, along Río Santa María; 2 (IML), Orán. *Remarks*.—One individual was collected at site 93.

Eptesicus diminutus Osgood, 1915

Records of occurrence.—1 (MACN), Aguaray. Crespo (1958) mentioned this species as *E. fidelis*, but see Williams (1978) for synonymy with *diminutus*. *Macroniche*.—Volant/aerial insectivore.

Eptesicus furinalis (D'Orbigny, 1847)

Records of occurrence.—5 (IML), Quebrada de Acambuco; 5 km. W Dique Itiyuro; 1 (MACN), Aguaray. Williams (1978) reported this species from 24 km. NW Aguas Blancas. *Remarks*.—Five individuals were collected at site 102 along a creek with slow-flowing water.

Histiotus macrotus (Poeppig, 1835)

Records of occurrence.—3 (BMNH), Río Piedras; 3 (IML), Quebrada de Acambuco; 5 km. W Dique Itiyuro. *Macroniche*.—Volant/aerial insectivore. *Remarks*.—These specimens were identified as *H. montanus* in Mares *et al.* (1981a). Three individuals were captured at site 102.

Histiotus montanus (Philippi and Landbeck, 1861)

Records of occurrence.—6 km. SSW Chicoana, 1400 m. (Villa-R. and Cornejo, 1969).

Lasiurus borealis (Müller, 1776)

Records of occurrence.—1 (CMNH), 15 km. S Orán, along Río Santa María; 1 (MACN), Orán. Villa-R. and Cornejo (1969) reported specimens from Rosario de Lerma, 25 km. SSW Salta; Finca La Florida. *Macroniche*.—Volant/aerial insectivore. *Remarks*.—Red bats were collected at sites 93 and 102.

Lasiurus cinereus (Palisot de Beauvois, 1796)

Records of occurrence.—3 (IML), Quebrada de Acambuco; Metán; Río Pescado, Orán. Villa-R. and Cornejo (1969) reported specimens from Cerrillos, 30 km. SW Salta. *Remarks*.—One individual was collected at site 102.

Family MOLOSSIDAE

Molossops planirostris (Peters, 1865)

Records of occurrence.—1 (IML), Quebrada de Acambuco; 5 km. W Dique Itiyuro (Olrog and Barquez, 1979). *Macroniche*.—Volant/aerial insectivore.

Molossops temmincki (Burmeister, 1854)

Records of occurrence.—21 (CMNH), 6 km. SW Santa Victoria E, at "El Breal"; 13 (IML), Quebrada de Acambuco; 5 km. W Dique Itiyuro; Laguna de los Panzones, Retiro; Río del Valle; Santa María E, 120 km. E Aguaray. Fornes and Massoia (1967) reported specimens from Santa Victoria E. *Remarks*.—Specimens were collected at the mesic enclave of site 132 within the chaco, and at sites 102 and 48 in the transitional forest macrohabitat.

Tadarida brasiliensis (É. Geoffroy St.-Hilaire, 1824)

Records of occurrence.—41 (MACN), Cafayate; Dragones; El Rey National Park (Parque El Rey); Lumbreras; Metán; Santa Victoria E, 300 m. Yepes (1944) reported on the specimens from Dragones and Lumbreras. Villa-R. and Cornejo (1969) collected this species 28 km. SSE Salta, Finca La Cruz. *Macroniche.*—Volant/aerial insectivore. *Remarks.*—This is a common species throughout much of its range. Numerous individuals were captured at site 89 in the central monte formation.

Nyctinomops laticaudatus (É. Geoffroy St.-Hilaire, 1805)

Records of occurrence.—1 (CMNH), 22 km. SW Orán, along Río Santa María. *Macroniche.*—Volant/aerial insectivore. *Remarks.*—Barquez and Ojeda (1975) reported the first record for Argentina.

Nyctinomops macrotis (Gray, 1839)

Records of occurrence.—1 (IML), Salta city (S. Guerrero, personal communication). Specimens from Yuto, Jujuy Province, were reported by Crespo (1958).

Eumops bonariensis (Peters, 1874)

Records of occurrence.—1 (CMNH), 15 km. S Orán, along Río Santa María; 2 (IML), Quebrada de Acambuco; 5 km. W Dique Itiyuro. Eger (1977) and Fornes and Massoia (1967) reported specimens from Santa Victoria E. *Macroniche.*—Volant/aerial insectivore.

Eumops glaucinus (Wagner, 1843)

Records of occurrence.—1 (IML), Yuto, Jujuy Province. *Remarks.*—The locality of Yuto in Jujuy Province is 10 kilometers from the Salta-Jujuy border.

Eumops perotis (Schinz, 1821)

Records of occurrence.—Campo Santo; Dragones; "Salta"; 30 km. NE Salta (Eger, 1977; Villa-R. and Cornejo, 1969).

Promops nasutus (Spix, 1823)

Records of occurrence.—8 (BMNH), Cachi, 2500 m. *Macroniche.*—Volant/aerial insectivore. *Remarks.*—Thomas (1915) proposed the specific name *ancilla* for the specimens from Cachi.

Molossus ater É. Geoffroy St.-Hilaire, 1805

Records of occurrence.—Salta city (Villa-R. and Cornejo, 1969). *Macroniche.*—Volant/aerial insectivore.

Molossus molossus (Pallas, 1766)

Records of occurrence.—2 (IML), Quebrada de Acambuco; 5 km. W Dique Itiyuro; 20 (MACN), Santa Victoria E; Tartagal. Fornes and Massoia (1967) reported specimens from Santa Victoria E under the name *M. major* (see Eger, 1977, for synonymy with *M. molossus*).

Order PRIMATES

Family CEBIDAE

Alouatta caraya (Humboldt, 1812)

Records of occurrence.—2 (IML), Orán, Urundel, Arroyo del Diablo. *Macroniche.*—Arboreal/frugivore-herbivore.

Cebus apella (Linnaeus, 1758)

Records of occurrence.—1 (IML), Urundel, Arroyo del Diablo; 36 (MACN), Playa Ancha; Río Blanco; Río Santa María; Urundel, El Bananal. *Macroniche.*—Arboreal/frugivore-granivore.

Order EDENTATA

Family MYRMECOPHAGIDAE

Myrmecophaga tridactyla Linnaeus, 1758

Records of occurrence.—2 (MACN), El Quebrachal; Santa Barbara. *Macroniche.*—Terrestrial/myrmecophage.

Tamandua tetradactyla (Linnaeus, 1758)

Records of occurrence.—1 (CMNH), Santa María E; 1 (IML), Tartagal; 7 (MACN), Agua Linda; Aguaray; Campamento, Salta; Dragones; Pozo Hondo; Río Santa María. *Macroniche.*—Scansorial/myrmecophage.

Family DASYPODIDAE

Chaetophractus vellerosus (Gray, 1865)

Records of occurrence.—3 (CMNH), 9.4 km. E Campo Durán; Santa Victoria E; 3 (IML), Orán; Río del Valle; Ruiz de los Llanos; 11 (MACN), Aguaray; Cabimonte; Cafayate; El Quebrachal; Padre Lozano; Rosario de la Frontera; Tabacal; San Antonio de los Cobres, 3650 m. *Macroniche.*—Semifossorial/insectivore-omnivore.

Euphractus sexcinctus (Linnaeus, 1758)

Records of occurrence.—2 (CMNH), Santa Victoria E; Yacimiento Tonono; 1 (IML), Hickman; 6 (MACN), Cerro Colorado, Metán; El Quebrachal; Lumberas; Manuela Pedraza. Yepes (1944) reported specimens from Tabacal. *Macroniche.*—Semifossorial/insectivore-omnivore.

Priodontes maximus Kerr, 1792

Records of occurrence.—1 (MACN), Urundel. *Macroniche.*—Semifossorial/myrmecophage.

Tolypeutes matacus (Desmarest, 1804)

Records of occurrence.—5 (CMNH), 5 km. W Jollín; 4 km. S Pocoy; Yacimiento Tonono; 6 (IML), Hickman; La Matanza (=Cañada La Matanza); Las Palmitas; Luna Muerta; San Francisco; 21 (MACN), Agua Linda; Cabimonte; Dragones; Embarcación; La Represa, Metán; Lumberas; Molinos; Rivadavia; Rosario de la Frontera; Tabacal. *Macroniche.*—Semifossorial/myrmecophage.

Dasypus novemcinctus Linnaeus, 1758

Records of occurrence.—1 (CMNH), 15 km. S Orán, along Río Santa María; Tabacal (Wetzel and Mondolfi, 1979; Yepes, 1944). *Macroniche.*—Terrestrial/insectivore-omnivore. *Remarks.*—Nine-banded armadillos were collected at sites 93 and 102 in the humid forest. Specimens from Salta described as *D. mazzai* by Yepes (1933a) are actually considered a "composite of *D. novemcinctus* and other species" (Wetzel and Mondolfi, 1979:51-55).

Dasypus septemcinctus Linnaeus, 1758

Records of occurrence.—1 (MACN), Tabacal (Wetzel and Mondolfi, 1979).

Chlamyphorus retusus (Burmeister, 1863)

Records of occurrence.—1 (MACN), La Angostura. *Macroniche.*—Fossorial/myrmecophage. *Remarks.*—This species is restricted to the formation known as “Gran Chaco” in southeastern Bolivia, western Paraguay, and northwestern Argentina (Wetzel, 1982; Yepes, 1939). The locality of Angostura (site 9) seems to be the southern limit for the species (Yepes, 1939). Another species, known as the lesser fairy armadillo, reaches its northernmost distribution in the locality of La Guardia (extreme southeastern Catamarca Province) and probably in the neighboring province of Santiago del Estero (Yepes, 1939).

Order LAGOMORPHA

Family LEPORIDAE

Sylvilagus brasiliensis (Linnaeus, 1758)

Records of occurrence.—2 (IML), La Junta (=Las Juntas); Metán; 15 (MACN) Cerro Capiazuti, Aguaray; Angostura; El Quebrachal; Manuel Elordi; Río Caraparí; Río Colorado; Río Pescado; Tabacal. *Macroniche.*—Terrestrial/herbivore. *Remarks.*—Thomas (1918) described the population from northwestern Argentina as *S. b. gibsoni*, with type locality at site 86. One individual was seen at site 48. Contrary to the assertion that the distribution of the tapetí is limited by such potential competitors as *Pediolagus salinicola* (Herskovitz, 1972:390), the locality of El Quebrachal (site 50) indicates that the species ranges into the chaco thorn scrub habitat of *P. salinicola*. Their coexistence involves differential microhabitat selection and activity rhythms (see results of Faunal Composition). The southwesternmost limit of distribution of *S. brasiliensis* is in the province of Tucumán (Cabrera, 1961).

Order RODENTIA

Family SCIURIDAE

Sciurus ignitus (Gray, 1867)

Records of occurrence.—2 (IML), Los Toldos; 1 (MACN), “Salta.” *Macroniche.*—Scansorial/frugivore-granivore. *Remarks.*—The southernmost records for *S. ignitus* are from the forests of southern Jujuy Province; these are housed at the IML collection and are from San Francisco, Dpto. Valle Grande, and El Jordan, Dpto. Calilegua. Thomas (1921) named this population as *S. argentinius*, with type locality in Higuera (2000 m.), 20 kilometers from Tilcara, Jujuy Province. One individual of *S. ignitus* was seen in El Monolito, Abra de Cañas (1700 m.), Jujuy Province (alder forest).

Family MURIDAE

Oryzomys legatus Thomas, 1925

Records of occurrence.—6 (CMNH), 24 km. NW Aguas Blancas; 17 km. SW Dique Itiyuro; 2 (IML), Aguas Blancas; Río Pescado. Massoia (1974) examined specimens from Aguaray. *Macroniche.*—Scansorial/frugivore-omnivore. *Remarks.*—This species was collected in the humid forest associated with creeks having flowing water at sites 7, 44, and 51. Individuals from site 51 contained a large number of red berries and a small percent of unidentified plants and insects in their stomachs. These localities are the southern limits of *O. legatus*.

Oryzomys longicaudatus (Bennett, 1832)

Records of occurrence.—26 (CMNH), 24 km. NW Aguas Blancas; 21 km. N Anta, along Río del Valle; Cerrillos, INTA Station; 17 km. SW Dique Itiyuro; 20 km. W General Ballivián, on Puerto Baulés Rd.; Juntas de San Antonio; 6 km. SW Santa Victoria E, at “El Breal”; 9 (IML), Orán; Río Pescado. *Remarks.*—This species is common in humid forest. Individuals were collected at sites 7, 8, 13, 35, 44, 48, 51, 54, 60, 64, and 132. Stomach contents of 19 animals from site 51 contained green material and insects in similar proportions.

Rhipidomys leucodactylus (Tschudi, 1845)

Records of occurrence.—2 (MACN), Aguaray; Río Santa María (upper course). *Macroniche.*—Arboreal/frugivore-omnivore. *Remarks.*—The southernmost distribution of this species is in central forested habitats of Jujuy Province (Olrog, 1976).

Akodon albiventer Thomas, 1897

Records of occurrence.—10 (CMNH), 14 km. S jct. Hwys. 40 and 51, along Hwy. 40, 4100 m., La Poma. *Macroniche.*—Terrestrial/insectivore-omnivore. *Remarks.*—Site 109 is the type locality (Thomas, 1897). Ten individuals were trapped at site 72 (4100 m.). In this analysis, *A. albiventer* is not considered part of the monte assemblage.

Akodon andinus (Philippi, 1858)

Records of occurrence.—2 (CMNH), 18 km. S jct. Hwys. 40 and 51, along Hwy. 40, 4500 m., La Poma. *Remarks.*—Collecting sites for this species are numbers 49, 65, 66, and 73. One female from site 66 (3760 m.) was lactating and molting during the late summer month of March.

Akodon boliviensis Meyen, 1833

Records of occurrence.—12 (BMNH), Dpto. Metán; La Cañada, Dpto. Metán 500 m.; La Represa, Dpto. Metán, 500 m.; 23 (CMNH), 24 km. NW Aguas Blancas; Cerrillos, INTA Station; Quebrada de San Lorenzo, 12 km. NW Salta. *Remarks.*—This species is found in grassy areas, secondary growth forest, and agricultural habitats. A preference for low-cover microhabitats was reported (Ojeda, 1979). Collecting localities include sites 7, 35, 48, and 60. Barquez *et al.* (1980) reported on karyology and morphometrics. Thomas (1897) named this species as *A. spegazzinii*, with the type locality in lower Río Cachi (near site 109). In this analysis, *A. boliviensis* is not considered part of the monte fauna.

Akodon varius Thomas, 1902

Records of occurrence.—4 (BMNH), Río Piedras; 66 (CMNH), 24 km. NW Aguas Blancas; 6 km. NE Cafayate, along Hwy. 68; 5 km. W Cafayate, Yacochuya; Cerrillos, INTA Station; 17 km. SW Dique Itiyuro; 20 km. W General Ballivián on Puerto Baulés Rd.; Juntas de San Antonio; 22 km. SW Orán, along Río Santa María; 20 km. S Pampa Grande, along Hwy. 9; 4 km. S Pocoy; 6 km. SW Santa Victoria E, at "El Breal"; 3 (IML) Cafayate; Orán. Thomas (1919) described specimens from Tartagal as *A. tartareus*. Yepes (1933b) mentioned specimens from Aguaray (under the name *A. sylvanus*). *Remarks.*—This species dominates the small mammal fauna in much of northwestern Argentina. It was captured in a wide variety of lowland habitats (sugar cane plantations, secondary growth, forest edges, grasslands, and riparian vegetation). Individuals were collected at sites 7, 8, 21, 24, 35, 44, 48, 51, 54, 60, 64, 92, 96, 100, and 132. In the semiarid monte, it is restricted to moist areas of dense vegetation and river banks (Mares, 1973, 1975). One individual was collected at site 132 (chacoan thorn scrub) near a natural lagoon. Preliminary observations of the rodent fauna in the transitional forest of Tucumán show *A. varius* as the dominant species in microhabitats of medium and high vegetation cover (Ojeda, 1979). Barquez *et al.* (1980) reported on karyology and morphometrics.

Oxymycterus paramensis Thomas, 1902

Records of occurrence.—6 (CMNH), 24 km. NW Aguas Blancas; 17 km. SW beyond Dique Itiyuro, 500 m.; 22 km. SW Orán, along Río Santa María; 3 (IML), Aguaray; 1 (MACN), Aguaray. *Macroniche.*—Terrestrial/insectivore-omnivore. *Remarks.*—This species was collected in humid forested habitats and stream banks at sites 7, 8, 44, and 92. Site 92 is the southernmost record for the species (Barquez, 1976).

Calomys callosus (Rengger, 1830)

Records of occurrence.—22 (CMNH), 21 km. N Anta, on El Piquete Rd. along Río del Valle; Cerrillos, INTA Station; 20 km. W General Ballivián on Puerto Baulés Rd.; 2 km. S Juntas de San Antonio; 15 km. S Orán, along Río Santa María; 4 km. S Pocoy; 22 km. SW Orán along Río Santa María; 2 (BMNH), Tabacal; G. M. Solá (=Gobernador Manuel Solá); 7 (IML), Aguaray; Orán; Tabacal. Hershkovitz (1962) examined specimens from Aguaray, Río Santa María, and Tartagal. *Macroniche.*—Scansorial/frugivore-omnivore. *Remarks.*—This is a common rodent in humid lowland habitats. Individuals were collected at sites 13, 35, 48, 51, 54, 60, 64, 92, 93, and 100.

Calomys laucha (Olfers, 1818)

Records of occurrence.—3 (CMNH), 5 km. NE Cafayate; 4 km. NE Santa Victoria E; 4 (IML), Río del Valle, Anta. Hershkovitz (1962) examined specimens from El Tala. *Remarks.*—Individuals were collected at sites 24 and 131 in monte and chaco macrohabitats, respectively.

Eligmodontia moreni (Thomas, 1896)

Records of occurrence.—2 (CMNH), 8.2 km. NE Cafayate, along Hwy. 68. *Macroniche.*—Terrestrial/frugivore-omnivore. *Remarks.*—Individuals of this lowland form are restricted to the monte macrohabitat. Collecting localities are sites 21 and 22. The use of the specific epithet, *moreni*, follows Mares and Braun (unpublished manuscript).

Eligmodontia puerulus (Philippi, 1896)

Records of occurrence.—3 (CMNH), 3 km. S jct. Hwys. 40 and 51, along Hwy. 40, 4000 m. (La Poma); 2 (MACN), Chorrillos, 4000-4500 m. *Remarks.*—This species is restricted to the puna macrohabitat (Mares and Braun, unpublished manuscript). Mares *et al.* (1981a) considered both species of *Eligmodontia* as *E. typus*. Collecting sites for *E. puerulus* include numbers 65, 71, and 125.

Phyllotis darwini (Waterhouse, 1837)

Records of occurrence.—10 (CMNH), 35 km. E Cachi, 3000 m.; 14 km. S jct. Hwys. 40 and 51, along Hwy. 40, 4000 m., La Poma; 4 km. S Tolombón, along Hwy. 40; 1 (MACN), San Antonio de Los Cobres, 3700 m. Hershkovitz (1962) examined specimens from G. M. Solá, 2500 m.; Inca Mayo; and San Antonio de Los Cobres. *Macroniche.*—Scansorial/frugivore-granivore. *Remarks.*—This is a common species along the pre-Andean and Andean ranges of northwest Salta. Collecting localities include sites 18, 49, 65, 66, 72, 125, and 141.

Auliscomys sublimis (Thomas, 1900)

Records of occurrence.—1 (CMNH), 14 km. S jct. Hwys. 40 and 51, along Hwy. 40, 4100 m., La Poma. *Macroniche.*—Terrestrial/herbivore. *Remarks.*—One individual was collected at site 72. Mares *et al.* (1981a) reported this locality as the southernmost record of the species.

Graomys domorum (Thomas, 1902)

Records of occurrence.—5 (CMNH), 11 km. N Anta, on El Piquete Rd.; 20 km. W General Ballivián, on Puerto Baulés Rd.; 4 km. S Pocoy. *Macroniche.*—Scansorial/frugivore-omnivore. *Remarks.*—This phyllotine seems to be restricted to the transitional forest. Eight individuals were collected at sites 12, 48, 54, and 100. One female was trapped in a tree at site 48. This record (site 48) is the southernmost record for the species.

Graomys griseoflavus (Waterhouse, 1837)

Records of occurrence.—5 (BMNH), Dpto. Metán; 30 (CMNH), 21 km. N Anta; about 30 km. E Cachi, 2600 m.; 30 km. S Cachi; 3 km. N Ceibalito; 3.7 km. N Ceibalito and jct. of Anta Rd. and Hwy. 16; 4 km. S Tolombón, along Hwy. 40; 2 km. W Santa María; 4 km. NE Santa

Victoria E; 6 km. SW Santa Victoria E, at "El Breal"; 27 km. E Tartagal; 2 (IML), Río Juramento, Metán; Río del Valle, Anta; 1 (MACN), Metán. Hershkovitz (1962) examined specimens from El Desmonte; La Represa; Macapillo; Manuel Elordi and Río Cachi. *Remarks.*—This is a common phyllotine in semiarid and arid habitats. Specimens were collected at sites 13, 17, 33, 89, 128, 131, 132, 138, and 141. Allen (1901) named the species as *Phyllotis cachinus* with type locality in upper Río Cachi (near site 109).

Andinomys edax Thomas, 1902

Macroniche.—Terrestrial/herbivore. *Remarks.*—Although not recorded from Salta, specimens are known from Sierra de Zenta (4500 m.), Jujuy Province, along the border of the central west portion of Salta. The geographic range of *Andinomys edax* extends from the puna of southern Perú to approximately 28° south latitude in northwestern Argentina. Individuals were collected at sites 49 and 60 in the province of Tucumán in the highland grassland and lowland forest, respectively.

Holochilus brasiliensis (Desmarest, 1819)

Records of occurrence.—31 (CMNH), Juntas de San Antonio; 6 km. SW Santa Victoria E, at "El Breal"; 10 (MACN), Río Pescado; Tabacal. *Macroniche.*—Scansorial/herbivore. *Remarks.*—Collecting sites comprise numbers 64 and 132. The species reaches its southernmost limits in Catamarca Province (Cabrera, 1961).

Family ERETHIZONTIDAE

Coendu prehensilis (Linnaeus, 1758)

Records of occurrence.—2 (IML), Coronel Cornejo; Tartagal. *Macroniche.*—Scansorial/herbivore. *Remarks.*—These are the southernmost records for the species.

Family CAVIIDAE

Microcavia australis (I. Geoffroy St.-Hilaire and D'Orbigny, 1833)

Records of occurrence.—2 (CMNH), 10 km. E. Cachi; 25 km. E Cachi; 13 (IML), Cafayate; 2 (MACN), Dragones; El Quebrachal. *Macroniche.*—Semifossorial/herbivore. *Remarks.*—Individuals were captured at sites 16, 17, and 89. In the last site, *M. australis* formed large colonies associated with low branching mesquite (*Prosopis flexuosa*) and spiny shrubs (*Condalia microphylla*, *Atamisquea emarginata*). The record from Dragones seems to constitute its northeastern limit of distribution (Mares *et al.*, 1981a).

Microcavia shiptoni (Thomas, 1915)

Records of occurrence.—1 (FMNH), Chorrillos; 8 (MACN), Chorrillos, 5000 m. and 4500 m.

Galea musteloides Meyen, 1832

Records of occurrence.—21 (BMNH), G. M. Solá; Inca Mayo; Metán; Río Piedras; 1 (AMNH), Rosario de Lerma; 2 (CMNH), Cerrillos, INTA Station; 14 km. S jct. Hwys. 40 and 51, along Hwy. 40, 4100 m., La Poma; 3 (IML), Las Lajitas; Río del Valle; San Antonio de Los Cobres; 27 (MACN), Agua Linda; El Quebrachal; Dragones; Lumbreras; Metán; San Antonio de Los Cobres; Tabacal. *Macroniche.*—Terrestrial/herbivore. *Remarks.*—Individuals were collected at sites 35, 48, 49, 72, 89, and 142 in low and high elevation grassland habitats. The biomass of *G. musteloides* in a 0.5-hectare grid at site 48 was more than 4000 grams during late autumn.

Pediolagus salinicola (Burmeister, 1875)

Records of occurrence.—1 (AMNH), Murillo; 3 (BMNH), El Desmonte, 500 m., Metán; Totoralejo; 6 (CMNH), 5 km. W Santa María E; 1 km. W Santa María E; 5 km. SE Santa María E; 4 km. NE Santa Victoria E; 3 (IML), Gavilan Pozo, 60 km. NE Joaquín V. Gonzalez;

Hickman; Macapillo; 4 (MACN), Dragones; Macapillo; Rivadavia. *Macroniche*.—Terrestrial/herbivore. *Remarks*.—This species is common in eastern Salta in the chaco macrohabitat. Six individuals were collected at sites 127, 128, and 131. Microhabitat features at these sites consisted of open thorn scrub forest with bare, hard soils (peladares). Individuals were seen in pairs along roads during diurnal and crepuscular hours. Honacki *et al.* (1982) listed the species under *Dolichotis*. The southern limit of *P. salinicola* is at approximately 33° south latitude. To the north of Salta, *Pediolagus* extends its range into the chacoan habitats of eastern Bolivia and Paraguay (Cabrera, 1953).

Family HYDROCHAERIDAE

Hydrochaeris hydrochaeris (Linnaeus, 1766)

Records of occurrence.—Crespo (1974) reported specimens from Valle Río Santa María, Orán (=Río Santa María). Capybaras seen near the confluences of the rivers Tarija and Bermejo were reported by Mares *et al.* (1981a). *Macroniche*.—Semiaquatic/herbivore. *Remarks*.—This species reaches its western limits in Argentina in Salta.

Family DASYPROCTIDAE

Dasyprocta punctata Gray, 1842

Records of occurrence.—3 (IML), Vado de Arrayazal, 20 km. NW Aguas Blancas; Los Madrejonas, Ríos Tarija e Itaú; 5 (MACN), Aguaray; Tabacal; Vespucio. Several agoutis were seen near the Río Pescado, 24 km. NW Aguas Blancas (Mares *et al.*, 1981a). Thomas (1918) described specimens from Manuel Elordi as *D. variegata boliviae*. *Macroniche*.—Terrestrial/frugivore-granivore. *Remarks*.—Individuals of this “obligate frugivore” (Eisenberg, 1981) were seen at sites 7 and 115. This species reaches its southwestern limits of distribution in forested macrohabitats at approximately 24° south latitude (see Fig. 9).

Family CHINCHILLIDAE

Lagostomus maximus (Desmarest, 1817)

Records of occurrence.—2 (CMNH), 5 or 6 km. W Santa Victoria E, at “El Breal”; 5 (IML), Las Lajitas; Rearte Norte, Rosario de la Frontera. Yepes (1944) reported specimens from Dragones. *Macroniche*.—Semifossorial/herbivore. *Remarks*.—This hystricognath is common in the chacoan thorn scrub of eastern Salta. Individuals were collected at sites 89 and 132. At site 89, various hystricognaths such as *Galea musteloides*, *Microcavia australis*, *Ctenomys eremicus*, *Dolichotis patagonum*, and *Lagostomus maximus*, coexist through differential microhabitat selection and time of activity.

Lagidium viscacia (Molina, 1782)

Records of occurrence.—1 (MACN), Chorrillos, 4700 m. *Macroniche*.—Saxicolous/herbivore. *Remarks*.—Individuals were observed at sites 123 and 65 (3200m.). It is a common herbivore in the rocky “island” microhabitats of the puna. In northwestern Argentina, it is restricted to the puna microhabitat, whereas in middle and southern latitudes it is found in the prepuna and Patagonian steppe habitats. Various individuals were seen at the localities of El Paramillo (32°31', 69°05') and Puesto El Peralito, Malargue (35°28', 69°35'), both in Mendoza Province. Fresh signs (fecal pellets) of this species were seen at site 66.

Chinchilla brevicaudata Waterhouse, 1848

Records of occurrence.—3 (MACN), Ex Los Andes, 3000 m (=Los Andes); Socompa. *Macroniche*.—Saxicolous/herbivore. *Remarks*.—Isolated populations of reduced numbers still may remain along the high Andean desert. Signs (fresh fecal pellets) were seen at site 66 (3760 m.) in a microhabitat of flat rocks. These formations are patchily distributed along the puna. Man-made traps used to capture this species were seen at this locality. The closest populated area to this site is Jagué (28°38', 68°24').

Family MYOCASTORIDAE

Myocastor coypus (Molina, 1782)

Records of occurrence.—3 (IML), Ciénagas, Juntas de Ríos Medina y Juramento; La Unión. *Macroniche.*—Semiaquatic/herbivore.

Family OCTODONTIDAE

Octodontomys gliroides (Gervais and D'Orbigny, 1844)

Records of occurrence.—9 (BMNH), G. M. Solá; Inca Mayo. Yepes (1942) recorded this species from Chorrillos, 5000 m.; San Antonio de Los Cobres, 3700 m. *Macroniche.*—Saxicolous/herbivore. *Remarks.*—An individual of *O. gliroides* was seen in the early afternoon along Highway 9, in the proximity of Maimará (23°37', 65°24'), Jujuy Province. This is a prepuna microhabitat, located at lower elevations than the specimens reported for Salta Province. The lowest elevation reported for this species is 1000 meters, in the locality of Villa Unión (29°18', 68°12'), La Rioja Province. This also represents the southern limit of its range (Yepes, 1936).

Family CTENOMYIDAE

Ctenomys frater Thomas, 1919

Records of occurrence.—2 (CMNH), 24 km. NW Aguas Blancas; 22 km. SW Orán, along Río Santa María; 3 (IML), Aguaray. *Macroniche.*—Fossorial/herbivore. *Remarks.*—Thomas (1919) described this species as *C. sylvanus frater*, with type locality at site 137.

Ctenomys mendocinus Philippi, 1869

Records of occurrence.—The British Museum has specimens from La Cañada and Dpto. Metán that appear to be *C. mendocinus*, although they are labeled *C. fochi*. Fresh burrows were observed in the chacoan thorn scrub community of eastern Salta (Estación Tonono) (Mares *et al.*, 1981a).

Ctenomys opimus Wagner, 1848

Records of occurrence.—1 (CMNH), 12 km. S jct. Hwys. 40 and 51, along Hwy. 40, 4000 m. (La Poma). *Remarks.*—An individual was collected near site 72. Various individuals, probably belonging to this species, were seen during high noon and early afternoon hours in the locality of Antofagasta de La Sierra (26°04', 67°25'), 3440 m., Catamarca Province.

Ctenomys saltarius Thomas, 1912

Records of occurrence.—1 (BMNH), Salta; 1 (CMNH), 4 km. S Tolombón, along Hwy. 40. *Remarks.*—An individual was collected at site 141. Thomas (1912) described the species with type locality in "Salta," with no other reference.

Family ABROCOMIDAE

Abrocoma cinerea Thomas, 1919

Records of occurrence.—1 (IML), San Antonio de Los Cobres; 5 (MACN), Chorrillos 4500 m.; San Antonio de Los Cobres, 3700 m. *Macroniche.*—Saxicolous/herbivore.

Order CARNIVORA

Family CANIDAE

Dusicyon culpaeus (Molina, 1782)

Records of occurrence.—3 (MACN), Cerro Aguaray; San Antonio de Los Cobres. *Macroniche.*—Terrestrial/carnivore-omnivore. *Remarks.*—An individual was seen at site 125 (4200 m.).

Dusicyon griseus (Gray, 1837)

Records of occurrence.—3 (BMNH), La Cañada, 500 m., Metán; Inca Mayo, 2300 m.; 1 (MACN), Tabacal. Yepes (1944) reported specimens from Los Blancos (near the border with the Province of Formosa in the chacoan thorn scrub).

Dusicyon gymnocercus (Fischer, 1814)

Records of occurrence.—7 (MACN), Aguaray; Agua Linda; Cerro Colorado, Metán; Dragones; Río Caraparí; Quebrada de Escoipe, Cerro Candadito.

Cerdocyon thous (Linnaeus, 1766)

Records of occurrence.—1 (BMNH), Río Piedras, 600 m.; 23 (MACN), Aguaray; Dragones; Cerro Colorado; Lumbreras; Orán; 35 km. E Orán; Pozo Hondo; Urundel, El Bananal; Santa María W. Mares *et al.* (1981a) reported that various individuals were seen in the area of Orán and Joaquín V. Gonzalez. Yepes (1944) reported specimens from El Tabacal. *Macroniche.*—Terrestrial/carnivore-omnivore. *Remarks.*—Individuals of the crab-eating fox were seen at site 90 and in the vicinity of Joaquín V. Gonzalez (25°05', 64°11').

Family PROCYONIDAE

Procyon cancrivorus (Cuvier, 1798)

Records of occurrence.—1 (MACN), Aguaray. *Macroniche.*—Scansorial/piscivore-crustaceivore.

Nasua nasua (Linnaeus, 1766)

Records of occurrence.—1 (CMNH), 15 km. W General Ballivián, on Puerto Baulés Rd.; 3 (IML), Orán; Urundel; 5 (MACN), Aguaray; Santa María W; Urundel, El Bananal. *Macroniche.*—Scansorial/insectivore-omnivore. *Remarks.*—An individual was collected at site 54 along a dry riverbed during daytime. The coati reaches its southern distribution in Tucumán Province, at approximately 27° south latitude.

Family MUSTELIDAE

Lyncodon patagonicus (Blainville, 1842)

Records of occurrence.—Olrog (1976) reported specimens from Cafayate and Alemania. *Macroniche.*—Terrestrial/insectivore-omnivore.

Galictis cuja (Molina, 1782)

Records of occurrence.—1 (BMNH), G. M. Solá; 4 (MACN), Cafayate; El Quebrachal; Lumbreras; Río Colorado. *Macroniche.*—Terrestrial/carnivore.

Eira barbara (Linnaeus, 1758)

Records of occurrence.—1 (MACN), Santa María W. A record near the confluence of the rivers Tarija and Bermejo was reported by Mares *et al.* (1981a). *Macroniche.*—Scansorial/carnivore. *Remarks.*—An individual was seen in the forested habitat of site 64. The southern limits of this species are at 27° south latitude in Tucumán Province.

Conepatus chinga (Molina, 1782)

Records of occurrence.—10 (BMNH), Cachi, 2500 m.; La Represa, Metán; La Cañada, Metán; 2 (IML), Junta de Ríos Medina and Juramento; Las Víboras, Anta; 13 (MACN), Chorrillos, 4500 m.; Dragones; El Quebrachal; La Represa, Metán; Rivadavia. *Macroniche.*—Terrestrial/insectivore-omnivore.

Lutra longicaudis (Olfers, 1818)

Records of occurrence.—Olrog (unpublished manuscript) mentioned its presence along the rivers Tarija, Itaú, Pilcomayo, and Bermejo. *Macroniche.*—Semiaquatic/piscivore-crustaceivore. *Remarks.*—Distribution of this species extends into Tucumán Province, at about 27° south latitude.

Family FELIDAE

Felis colocolo Molina, 1810

Records of occurrence.—2 (MACN), Aguaray; Chorrillos, 4500 m. The type locality for *F. c. budini* is Cerro Solo, 2500 m., for a specimen in the British Museum of Natural History. *Macroniche.*—Terrestrial/carnivore. *Remarks.*—A. Cabrera (1957) named *F. c. crespói* based on the specimen from Aguaray, and used *F. c. budini* for the specimens from Cerro Solo and Chorrillos.

Felis tigrina Schreber, 1775

Records of occurrence.—1 (MACN), Angostura. *Remarks.*—This record might constitute the westernmost distribution of the species (A. Cabrera, 1957).

Felis geoffroyi D'Orbigny and Gervais, 1844

Records of occurrence.—3 (IML), Hickman; Las Víboras; Cañada Mendoza; 4 (MACN), Aguaray; Angostura; Dragones; El Tabacal.

Felis wiedii Schinz, 1821

Records of occurrence.—1 (MACN), Pichanal. *Remarks.*—An individual kept in captivity was seen at site 147 near where it had been collected. The southern limit for this cat is at about 24° south latitude. No records exist from the southern forest of Tucumán Province.

Felis yagouaroundi É. Geoffroy St.-Hilaire, 1803

Records of occurrence.—2 (MACN), Aguaray; Angostura; Dragones (Yepes, 1944). Individuals seen along Río Pescado, 24 km. NW Aguas Blancas were reported by Mares *et al.* (1981a).

Felis concolor Linnaeus, 1771

Records of occurrence.—8 (MACN), Aguaray; Dragones; El Quebrachal; Lumbreras; near Orán; 15 km. E Rosario de la Frontera; Urundel, El Bananal. *Remarks.*—This is a heavily hunted species in northwestern Argentina. Individuals were seen in the chacoan forest of Santiago del Estero Province and at site 89.

Panthera onca (Linnaeus, 1758)

Records of occurrence.—Mares *et al.* (1981a) reported signs of jaguar 24 km. NW Aguas Blancas. *Macroniche.*—Terrestrial/carnivore. *Remarks.*—This species has been recently extirpated from the southern forested macrohabitats.

Order PERISSODACTYLA

Family TAPIRIDAE

Tapirus terrestris (Linnaeus, 1758)

Records of occurrence.—2 (MACN), Orán; Río Colorado. Tracks of tapirs were reported from the proximity of Aguas Blancas (Mares *et al.*, 1981a). *Macroniche.*—Semiaquatic herbivore. *Remarks.*—Ameghino (1909) named the species *T. spegazzini*, with site 115 as type locality. Tapirs have been extirpated recently from the southern forests in Tucumán Province.

Order ARTIODACTYLA

Family TAYASSUIDAE

Tayassu tajacu (Linnaeus, 1758)

Records of occurrence.—4 (CMNH), 4 km. S Pocomo; 1 (IML), Urundel, Arroyo del Diablo; 3 (MACN), Dragones; 15 km. SE Dragones; Urundel (=Urundel, El Bananal). *Macroniche.*—Terrestrial/frugivore-omnivore.

Catagonus wagneri (Rusconi, 1930)

Records of occurrence.—2 (MACN), Dragones; unknown locality (Wetzel and Crespo, 1975; Wetzel, 1977). *Macroniche.*—Terrestrial/frugivore-omnivore. *Remarks.*—According to local residents, this peccary is fairly common near site 140. Olrog *et al.* (1976) described this species from the chacoan thorn scrub of Santiago del Estero Province.

Family CERVIDAE

Mazama americana (Erxleben, 1777)

Records of occurrence.—Cabrera (1961) mentioned *M. a. sarae* in the montane forests along the Bolivian border. *Macroniche.*—Terrestrial/herbivore. *Remarks.*—Various individuals were seen along the chacoan and transitional vegetational formations.

Mazama gouazoubira (Fischer, 1814)

Records of occurrence.—4 (MACN), Cerro Colorado, 800 m.; Lumbra Río Colorado, 650 m.; Río Santa María; Santa María (Crespo, 1974). *Remarks.*—Mares *et al.* (1981a) reported various individuals seen in the chaco and transitional forest habitats in northern Salta.

Blastoceros dichotomus (Illiger, 1815)

Records of occurrence.—This species was present approximately 30 to 40 years ago in northeastern Salta Province along the river Pilcomayo and flooded areas on the border with Bolivia and Paraguay (J. C. S. Toledo and C. C. Olrog, personal communication). *Macroniche.*—Terrestrial/herbivore.

Ozotoceros bezoarticus (Linnaeus, 1758)

Records of occurrence.—This species occurred in southeastern Salta about 40 years ago (C. C. Olrog and J. C. S. Toledo, personal communication). The pampas deer has been extirpated from northwestern Argentina and from most parts of its original range. *Macroniche.*—Terrestrial/herbivore.

Family CAMELIDAE

Lama guanicoe (Müller, 1776)

Records of occurrence.—Mares *et al.* (1981a) reported seeing guanacos near Cachi and San Antonio de Los Cobres. Cajal *et al.* (1983) reported individuals from the Los Andes reserve. J. Cajal (personal communication) reported *Lama guanicoe* and *Vicugna vicugna* co-occurring at Abra de Acay. *Macroniche.*—Terrestrial/herbivore. *Remarks.*—This large herbivore was seen near sites 16 and 123, and in sites 65, 66, and 125 in the puna. The largest populations of guanacos in the puna are concentrated in protected areas (Cajal, 1983; Cajal *et al.*, 1983). During the Pleistocene, the guanaco extended its range into the province of Buenos Aires (Tonni and Politis, 1978). The species was present in recent times in the locality of Ñacuñan (site 89) in Mendoza Province (Contreras, 1979).

Vicugna vicugna (Molina, 1782)

Records of occurrence.—Cajal *et al.* (1983) reported a population of 575 vicuñas in the department of Los Andes. *Macroniche.*—Terrestrial/herbivore. *Remarks.*—This species coexists

with the guanaco in large portions of the puna in Argentina (Cajal, 1983). Vicuñas were seen at sites 65, 66, and 125. Site 125 constitutes the southern limit for the species. As with the guanaco, vicuña populations are concentrated in a chain of isolated reserves along the puna. Unlike the guanaco, the vicuña shows a permanent territory and a stronger affinity with the puna habitat (Franklin, 1982).

Mammalian Assemblages

Faunal Similarity

Results of the cluster analysis of the simple matching coefficients (S_{SM}) among the mammal assemblages are presented in Figure 7. The similarity matrices for species, genera, and families are shown in Tables 3-5. High cophenetic correlation coefficients are observed at both the specific and generic levels ($r = 0.82$), whereas a lower cophenetic correlation coefficient is obtained for the familial level analysis ($r = 0.70$).

The degree of interrelationship between the assemblages varies with the taxonomic level employed in the clustering algorithm. At all three levels (species, genus, and family), however, the OTUs are clearly divisible into two primary groups.

The two major clusters, which we here term the "aridlands" and "forests" faunas, reflect the composite nature of the area. The "forests" cluster resembles the "Yungas" province (Cabrera and Willink, 1973), or moist forest. In the southern portion of this macrohabitat (northwestern Argentina), this forest intrudes, peninsula-like, between the semiarid chaco to the east, and the monte, prepuna and puna to the west. Its roughly longitudinal north-south extension of 685 kilometers shows a gradual narrowing, with the formation being discontinuous in the middle portion of the "peninsula."

The "aridlands" cluster grouped three closely related vegetational provinces of the Chacoan Domain; the chaco, prepuna, and monte, and one phytogeographic unit of the Andean-Patagonian Domain, the puna.

Several mammalian assemblages are segregated in the cluster analysis of species (with $r = 0.76$). Within the "aridlands," the puna, prepuna, and upper montane forest are grouped together in a cluster hereafter referred to as the highlands mammal assemblage. (This grouping of three of the eight original faunas and the combining of the chaco and montane chaco into a single faunal assemblage (below), results in the original faunas being reduced to five major mammal assemblages). As noted, data for the upper montane forest fauna have been obtained in the grassland community above 2000 meters. This community shows a marked relationship with the prepuna. This also coincides with the definition of "humid puna" employed by some phytogeographers to characterize the upper montane grassland community (Vervoort, 1982).

The monte assemblage in this northern portion of its range is limited by the pre-Andean mountain ranges and the humid forests. To the north, its limits intergrade with the prepuna and with the puna above 3000 meters. The monte and chaco establish a narrow contact zone in the southwestern

A)

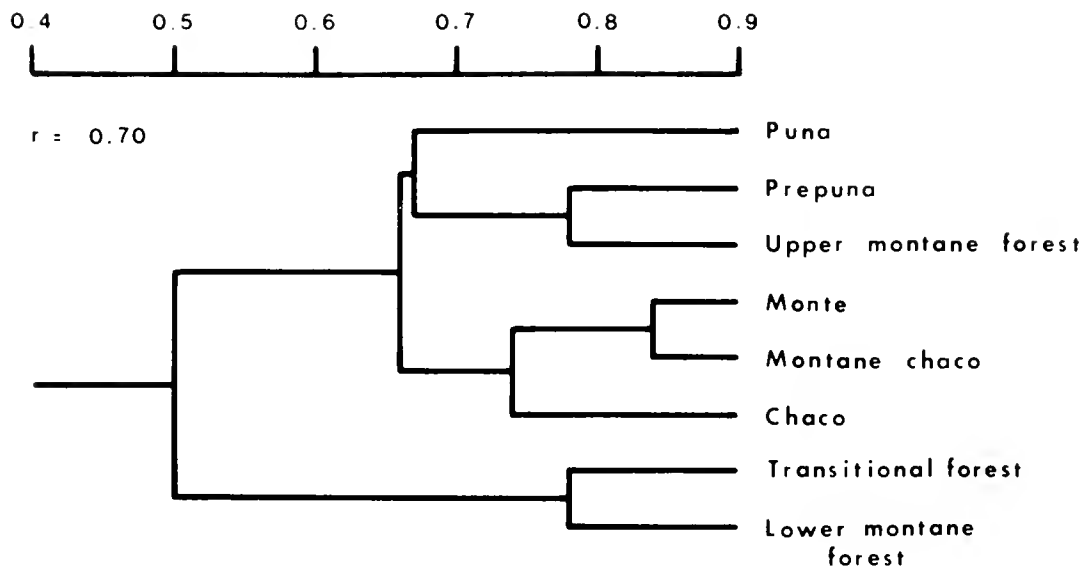

B)

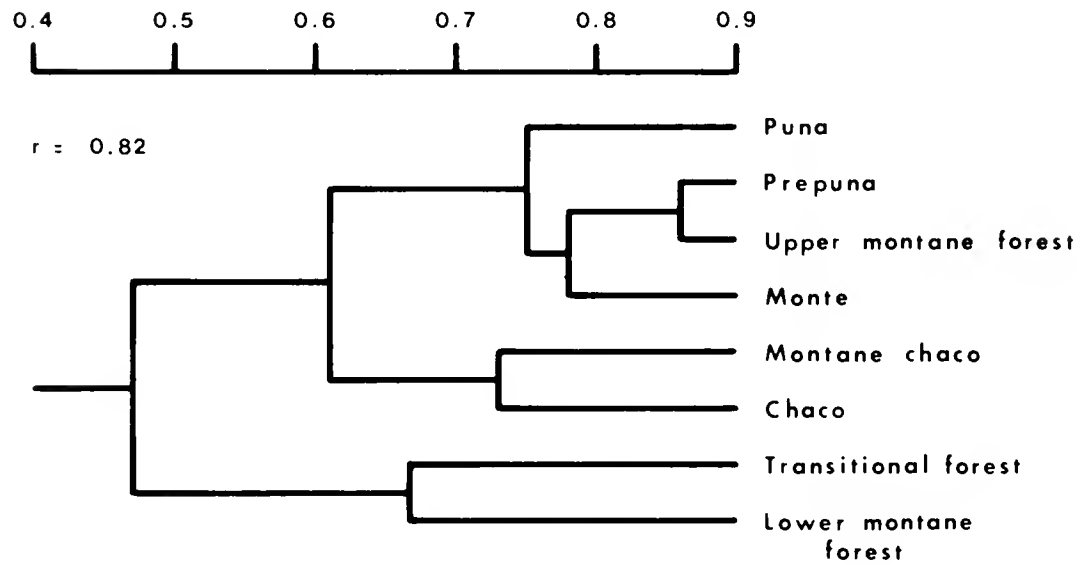

C)

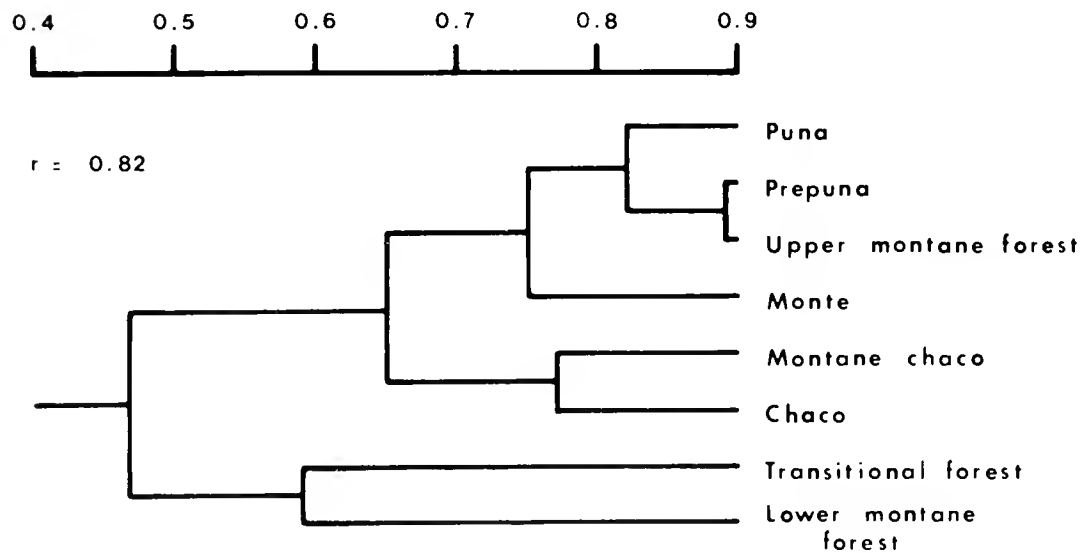

FIG. 7.—Dendrograms of macrohabitat affinities based upon mammal taxonomic similarity at the familial (A), generic (B), and specific (C) levels. Cophenetic correlations (r) are shown.

TABLE 3. *Similarity matrix (simple matching coefficient) of primary mammalian assemblages at specific level.*

Macrohabitats	Macrohabitats							
	Puna	Prepuna	Monte	Upper montane	Lower montane	Transitional	Montane chaco	Chaco
Puna	1.00							
Prepuna	0.83	1.00						
Monte	0.67	0.82	1.00					
Upper montane	0.80	0.89	0.76	1.00				
Lower montane	0.47	0.59	0.56	0.65	1.00			
Transitional	0.26	0.33	0.39	0.39	0.59	1.00		
Montane chaco	0.65	0.75	0.77	0.74	0.57	0.50	1.00	
Chaco	0.48	0.58	0.64	0.58	0.49	0.50	0.77	1.00

Ravine of the Conchas. A complex ecotonal area between these formations is formed south of 28° south latitude as the pampean mountain ranges decrease in elevation (Morello, 1958).

The chacoan faunal assemblage (comprising the faunas of the chaco and montane chaco) grades toward the west to the transitional forest fauna and, in the lower mountain ranges, to the highlands assemblage (grassland community). To the east, as precipitation increases, the chaco incorporates a wide variety of mammalian species from the Brazilian highlands and Patagonia in what Hershkovitz (1972) defined as the Paraná-Paraguay valley district.

Among the “forests” components, the lower montane forest and transitional forest assemblages are clearly ($S_{SM} > 0.66$) separated at the generic and specific levels. The two most dissimilar groups are the highlands and transitional assemblages, as reflected in the low values of the coefficients. The monte assemblage acts as the link between the montane chaco and highlands groups. The contact between the “aridlands” and “forests” is established through the transitional assemblage.

TABLE 4. *Similarity matrix (simple matching coefficient) of primary mammalian assemblages at generic level.*

Macrohabitats	Macrohabitats							
	Puna	Prepuna	Monte	Upper montane	Lower montane	Transitional	Montane chaco	Chaco
Puna	1.00							
Prepuna	0.79	1.00						
Monte	0.71	0.79	1.00					
Upper montane	0.74	0.87	0.76	1.00				
Lower montane	0.38	0.48	0.53	0.56	1.00			
Transitional	0.30	0.35	0.46	0.41	0.66	1.00		
Montane chaco	0.62	0.73	0.75	0.70	0.52	0.60	1.00	
Chaco	0.46	0.51	0.59	0.51	0.46	0.61	0.73	1.00

TABLE 5. *Similarity matrix (simple matching coefficient) of primary mammalian assemblages at familial level.*

Macrohabitats	Macrohabitats							
	Puna	Prepuna	Monte	Upper montane	Lower montane	Transitional	Montane chaco	Chaco
Puna	1.00							
Prepuna	0.71	1.00						
Monte	0.71	0.71	1.00					
Upper montane	0.64	0.78	0.78	1.00				
Lower montane	0.32	0.46	0.60	0.53	1.00			
Transitional	0.32	0.32	0.60	0.39	0.78	1.00		
Montane chaco	0.71	0.78	0.85	0.71	0.53	0.53	1.00	
Chaco	0.53	0.53	0.75	0.53	0.64	0.78	0.75	1.00

Coefficients of community (CC) for similarity analyses at the specific level for the eight original mammalian assemblages are shown in Table 6. The highest coefficient was found between the montane chaco-chaco comparison (0.66), followed by the lower montane forest-transitional forest (0.58). The lowest CC (0) is observed between the puna-prepuna as compared with the lower montane forest (Table 6). A constellation diagram showing the interrelationships as percent similarity at the specific level of the eight primary mammal faunas is shown in Figure 8.

Macroniche Organization

Thirty-four feeding-substrate macroniches are represented among the mammals of Salta (Table 7). The number of occupied macroniches increases from highlands to lowlands, as does species density. The transitional faunal assemblage shows the most macroniches occupied (27), whereas the monte assemblage had the fewest cells filled (13). The "forests" fauna has the terrestrial and fossorial myrmecophage and semifossorial and saxicolous

TABLE 6. *Similarity matrix for primary assemblages at specific level. Coefficients of community (CC) are shown above the diagonal. Absolute numbers of species in common appear below the diagonal.*

Macrohabitats	Macrohabitats							
	Puna	Prepuna	Monte	Upper montane	Lower montane	Transitional	Montane chaco	Chaco
Puna	—	.31	.15	.27	0	.06	.12	.09
Prepuna	4	—	.31	.20	0	.02	.18	.11
Monte	3	4	—	.19	.20	.26	.51	.42
Upper montane	4	2	3	—	.20	.15	.22	.18
Lower montane	0	0	6	5	—	.58	.27	.33
Transitional	3	1	12	6	32	—	.43	.51
Montane chaco	3	3	12	4	9	21	—	.66
Chaco	3	3	14	5	14	30	24	—

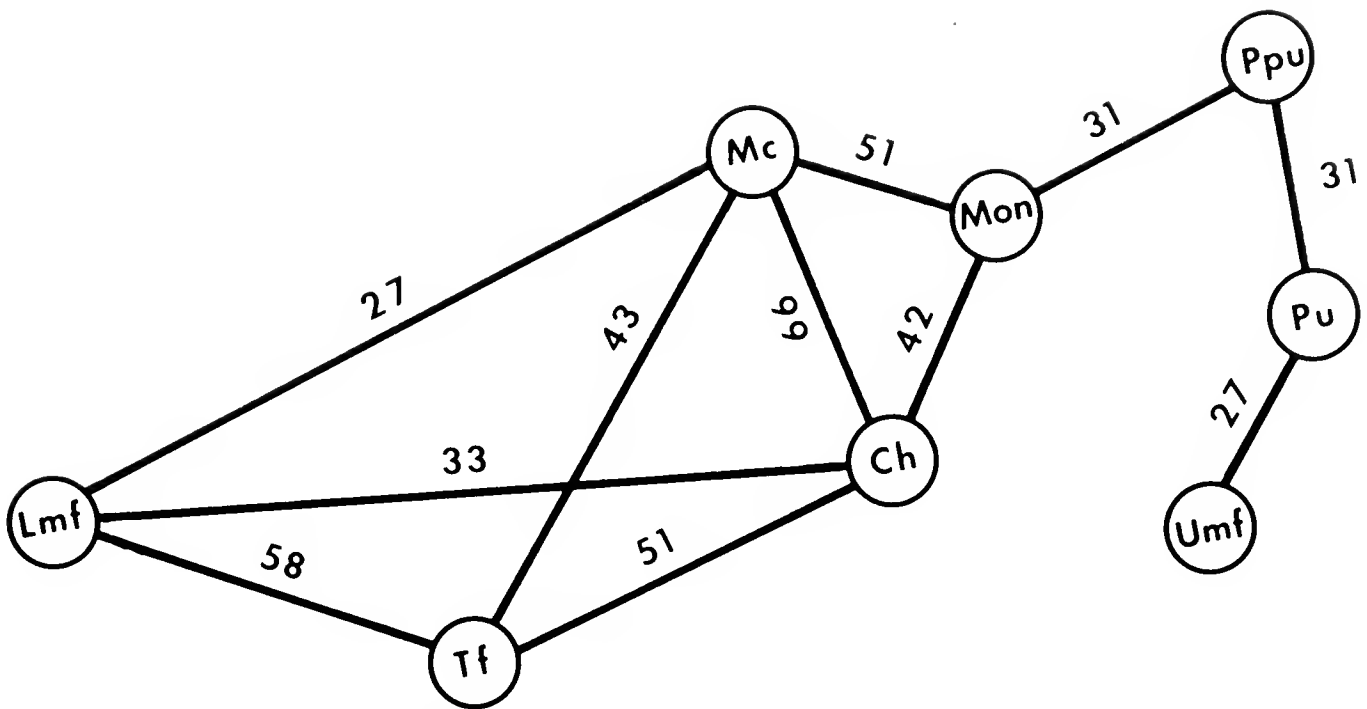

FIG. 8.—Constellation diagram among the primary assemblages based on similarity at the species level. Coefficients of community (expressed as percent) are shown between assemblages. Only values at or above 27 percent species similarity are shown. Abbreviations as in Figure 6.

herbivore macroniches unfilled. Twenty-two of the 34 possible macroniches are filled in the “aridlands” faunal assemblages.

Substrate Adaptations

Substrate adaptations of the five assemblages are shown in Table 7. Marked differences ($X^2 = 8.22$; $df = 3$; $.05 > P > .025$) in the occupancy of substrate categories were found between the three aridlands faunas and the two forests faunas. A higher level of significance was obtained in comparing scansorial-arboreal forms versus other adaptations (bats excluded) ($X^2 = 5.8$; $df = 1$; $.025 > P > .01$). A trend toward an increasing percentage of terrestrial species is found from lowland forests to semiarid and high altitude habitats. An opposite trend is observed in the volant and scansorial macroniche dimensions.

Arboreal adaptations occur only in the lower montane and transitional assemblages among primates (*Alouatta* and *Cebus*), and a cricetid, *Rhipidomys*. Saxicolous adaptations are found only in the highlands; rock outcrop formations are absent in the lowlands. Scansorial adaptations occur mainly in the highlands assemblage, among marsupials, *Marmosa* and *Didelphis*, and the phyllotines, *Graomys* and *Phyllotis*.

Semiaquatic adaptations do not occur at high altitudes or in deserts. The semiaquatic hystricognath, *Myocastor*, is found in the chaco, and enters the transitional forest along the rivers Bermejo, Medina, and Juramento, and along secondary courses. The semiaquatic tapir (*Tapirus terrestris*), capybara (*Hydrochaeris hydrochaeris*), and the river otter, *Lutra longicaudis*, occur in forests.

TABLE 7. *Distribution of macroniches among the five major mammalian assemblages of Salta Province. Abbreviations: FOSSO, Fossorial; SEMFO, semifossorial; SEMAQ, semiaquatic; VOLAN, volant; TERRE, terrestrial; SCANS, scansorial; ARBOR, arboreal; SAXIC, saxicolous; PISCR, piscivore-crustacivore; CARNI, carnivore; CARNIOM, carnivore-omnivore; NECTA, nectarivore; MYRME, myrmecophagous; AEINS, aerial-insectivore; FOGLI, foliage gleaning-insectivore; INSOM, insectivore-omnivore; FRUGI, frugivore; FRUM, frugivore-omnivore; FRUGR, frugivore-granivore; FRUHE, frugivore-herbivore; HERBI, herbivore; SANGU, sanguivore. H' is macroniche diversity; E is macroniche evenness. Values sharing a superscript are not significantly different (see text).*

Macroniche	Mammalian Faunal Assemblage				
	Highlands	Monte	Chaco	Lower montane	Transitional
FOSSO/MYRME	—	—	1	—	—
FOSSO/HERBI	1	1	1	1	1
SEMFO MYRME	—	—	2	—	2
SEMFO/INSOM	1	12	2	—	2
SEMFO/HERBI	1	1	2	—	—
SEMAQ/PISCR	—	—	—	1	1
SEMAQ/HERBI	—	—	1	2	2
VOLAN/PISCR	—	—	1	1	1
VOLAN/CARNI	—	—	—	1	—
VOLAN/NECTA	—	—	—	2	1
VOLAN/AEINS	1	5	11	4	16
VOLAN/FOGLI	—	—	—	—	1
VOLAN/FRUGI	—	1	—	4	3
VOLAN/SANGU	1	1	1	1	2
TERRE/CARNI	3	3	5	2	6
TERRE/CARNIOM	1	1	3	1	3
TERRE/MYRME	—	—	1	—	—
TERRE/INSOM	3	2	2	3	6
TERRE/FRUOM	1	1	2	—	1
TERRE/FRUGR	—	—	—	1	1
TERRE/HERBI	5	—	6	2	4
SCANS/PISCR	—	—	—	1	1
SCANS/CARNI	—	—	—	1	1
SCANS/CARNIOM	—	—	—	1	—
SCANS/MYRME	—	—	1	1	1
SCANS/INSOM	2	2	3	2	5
SCANS/FRUOM	1	2	3	3	4
SCANS/FRUGR	1	1	—	1	—
SCANS/FRUHE	—	—	—	—	1
SCANS/HERBI	—	—	1	1	1
ARBOR/FRUOM	—	—	—	1	1
ARBOR/FRUGR	—	—	—	1	1
ARBOR/FRUHE	—	—	—	1	1
SAXIC HERBI	4	—	—	—	—
Macroniches	14	13	19	25	27
Total Species	26	22	49	40	70
H'	2.40 ^a	2.37 ^a	2.59 ^{a,c}	3.07 ^b	2.82 ^{b,c}
E	0.91	0.92	0.88	0.95	0.86

Semifossorial adaptations are absent from the lower montane assemblage. Semifossorial species reach their greatest diversity in thorn scrub habitats of the chaco, where two caviids, a chinchillid, and three species of edentates occur. The fossorial niche is filled in every faunal assemblage by the genus *Ctenomys*, whereas the fairy armadillo, *Chlamyphorus retusa*, is restricted to the chaco.

Feeding Adaptations

A 43 percent decrease in richness of feeding adaptations occurs from the transitional forest to the highlands (data available from Table 7). Niche categories present in all five faunal assemblages are the carnivores, carnivore-omnivores, aerial insectivores, insectivore-omnivores, herbivores, and sanguivores.

Among the feeding categories, markedly fewer cases of frugivorous and nectarivorous habits than of other feeding adaptations ($X^2 = 17.6$; $df = 1$; $P < .005$) were found in aridlands than in forests. Herbivorous species were significantly more prevalent ($X^2 = 4.98$; $df = 1$; $.05 > P > .025$) than nonherbivorous species in the aridland faunas rather than in the forest faunas.

Some of the observed trends are the result of a decrease in the proportion of insectivore-omnivores from the arid highlands to the humid forests, and an increase in the proportion of herbivores from the lowlands to highlands assemblages. The proportion of carnivores and carnivore-omnivores is similar among these faunas, between 14 and 17 percent of the total fauna. Noticeably fewer aerial insectivores occur in the lower montane and highlands faunas.

The nectarivores and frugivore-herbivores are limited to humid forests. The only foliage gleaner in the transitional assemblage is *Tonatia sylvicola*. No piscivore-crustacivore occurs in the monte and highland faunas. Myrmecophagy is restricted to the edentates and becomes proportionally more important from the lower montane to the transitional and chaco faunas, being absent in the monte and highlands.

Macroniche Diversity

The distribution of species in macroniche space and parameters of macroniche diversity are shown in Table 7. Diversity indices were compared among these five faunas. The variance of the estimate of H' (Poole, 1974) was obtained for each assemblage and compared with a t -test to test for significant differences (Table 7).

The highest diversity ($H' = 3.07$) and equitability ($E = .95$) are in the lower montane fauna. The lowest diversity occurs in the monte assemblage. The number of macroniches in the lower montane fauna is significantly greater than in the highlands, monte, or chaco assemblages ($P < 0.001$; $P < 0.001$; and $0.01 > P > 0.001$, respectively). The lower montane and

transitional assemblages are not significantly different. At a lower level of significance ($0.05 > P > 0.01$), the transitional assemblage differs from the highlands and monte. No marked difference was observed between the transitional and chaco assemblages.

Marconiche diversity indices (H' in Table 7) show no differences between the highlands, monte, and chaco assemblages. Evenness indices (E in Table 7) are lower in the chaco and transitional assemblages.

DISCUSSION

The distribution of animals and plants in a region is the result of a complex interplay of historical, evolutionary, and ecological factors acting over different time scales. The mammalian fauna of Salta reflects processes that have operated in South America for millions of years. In northwestern Argentina, tropical and temperate climates meet. The area is also a major interface between two well-established faunas of the Neotropical region—the forest and aridland assemblages.

Woodlands and more open vegetation both have been present in South America since the early Tertiary (Webb, 1978) and, as these have expanded and contracted during the late Tertiary and Quaternary, the ranges of associated mammals responded in kind (Pascual and Rivas, 1971; Patterson and Pascual, 1972; Simpson and Vervoort, 1977; Solbrig, 1976; Vuilleumier, 1971; Webb, 1978). The presence of primates, anteaters, porcupines, spiny rats, and dasyproctids during the Oligocene in southern Patagonia suggests milder climates and a gradation of woodland and savannah macrohabitats at that time (Patterson and Pascual, 1972). Today, similar forests in Argentina are restricted to two isolated areas in the northwestern and northeastern part of the country. Thus, there has been a significant contraction of forests since the Tertiary. Some groups, such as the echimyids, that were present in Patagonia in the Oligocene, are found today approximately 800 kilometers east or north of Argentina. Other groups, such as primates, dasyproctids, and porcupines, also part of the woodland-Patagonia assemblage in the late Quaternary, reach their southern limits along the forest corridor of northwestern Argentina.

This departs from what some biogeographers have expressed. Fittkau (1969:631) wrote “. . . the biotope of the very diverse forest fauna (in South America) has not been restricted to any significant degree by the subsequent post-pluvial regression of the forests.” Climatic fluctuations have been suggested as causative agents for the fragmentation or contraction of forest habitats during dry periods, with expansion of these habitats during warmer and humid periods. The reverse is postulated for savannas (Simpson and Haffer, 1978; Vuilleumier, 1971).

Northwestern Argentina has been recognized, to different degrees, as a transitional zone between the tropical Guiana-Brazilian and temperate Chilean regions since Wallace's (1876) regionalization of South America, but no analysis of a complete major taxon within northwestern Argentina has been made. This has contributed to different interpretations of mammalian faunal areas (Cabrera and Yepes, 1960; Hershkovitz, 1958; Koopman, 1976, 1982; Schmarda, 1853; Smith, 1983a, 1983b). Hershkovitz (1958, 1972) noted that except for the sanguivorous *Desmodus*, all Patagonian bats are insectivorous. This is partially correct in an ecological sense, but not in the sense referred to by Hershkovitz. Although insectivorous bats monopolize semiarid temperate macrohabitats, such as the chaco and monte, mostly noninsectivorous genera such as *Noctilio* and *Sturnira* occur in northwest-

ern Argentina, and a number of bats, such as among the Noctilionidae and Phyllostomidae, occur in the chaco of Paraguay (Myers, 1982). These areas are part of the Patagonian subregion in Hershkovitz's scheme. Smith's (1983a, 1983b) "closely packed" regionalization at the family level, considered northwestern Argentina as belonging to the Argentinian subregion. This delineation is derived from the distributional ranges of the temperate fauna. Unfortunately, the range maps used by Smith were not correct in important details, and a group of tropically-adapted species that intrudes into the temperate zone was excluded from the analysis. This lack of detail (Smith used only familial distributions), although recognized by Smith (1983a:461), resulted in the compression of the 24 subregions of the Wallace classification into the proposed 10 new subregions.

The mammalian fauna of northwestern Argentina, when compared with previous classifications made on a continental scale (Hershkovitz, 1958), shows that 83 percent of the genera are endemic to South America, with the rest being cosmopolites, or of uncertain origin. Of the 83 percent, 28 percent are endemic to the Patagonian subregion, 32 percent to the Brazilian subregion, and 18 percent occur in both subregions. Fifty percent of the families present in northwestern Argentina are endemic to the Neotropical region (Hershkovitz, 1972). Abrupt changes in the mammalian faunas coincide with abrupt changes in topography and accompanying climatic and vegetational features. In the absence of such abrupt changes in the environment of mammals, faunal "boundaries" would form continua. This is a well known pattern in vegetational communities (Beals, 1969). Thus, whereas the fauna of the puna consists almost entirely of Patagonian endemics, at lower elevations more Brazilian taxa occur. There is a low degree of interrelationship between the highlands and lower montane mammal assemblages. The similarity of the interrelationships among the aridlands mammalian fauna and those of aridland floras (compare Sarmiento, 1975) suggest similar evolutionary histories during the Tertiary and Quaternary events.

In the northern part of the monte, the mammalian fauna is less distinctive than in the west-central part, where endemics such as *Andalgalomys olrogi*, *Tympanoctomys barrerae*, *Octomys mimax* (Rodentia), and *Chlamyphorous truncatus* (Edentata) occur. In dealing with the floras of aridlands, Sarmiento (1975:249) concluded that the affinities between the monte and chaco "are much stronger than the relationships between the monte and any other dry flora, except the Prepuna."

The dissimilarity seen between the high Andean flora and the other aridland floras (Sarmiento, 1975) also is seen between the mammal faunas. A number of highland species of different lineages or historical components (Reig, 1981; Savage, 1974) are restricted to the puna.

The fauna of the geographically intermediate monte is also intermediate to the faunas of the highlands and of the semiarid chaco. A stronger connection of highland faunas and those of lowlands would be expected

farther south. Various closely related species or subspecies in the puna and Patagonia faunas have been described by Hershkovitz (1972) and Müller (1973). The fauna of the puna may have resulted when lowland species from grasslands spread into widely separated pockets of semiarid vegetation at higher altitudes (Hershkovitz, 1972:413, the dispersalist model). Müller (1973) suggested a combination of dispersal and vicariance due to the elevation of different taxa into cooler zones.

The chacoan fauna of northwestern Argentina is similar to that of the Chaco Boreal of Paraguay. Most of the rodent species restricted in Paraguay to the thorn scrub (Myers, 1982) occur also in the chaco of Salta. However, some of the species cited by Myers as restricted to the chaco formation in Paraguay attain a wider habitat occupancy in northwestern Argentina. This is the case of species such as *Akodon varius* and *Calomys callosus*. This affinity between the Paraguayan and Argentinian chaco suggests that the Pilcomayo River (on the border between Argentina and Paraguay) is no great obstacle. In contrast, however, the forest faunas of eastern Paraguay and northwestern Argentina contain many different tropical elements. Paraguay has tropical species from the eastern Atlantic rainforest as well as from the Amazonian lowlands, whereas tropical species in Salta Province are derived from tropical habitats in western South America. Different populations of *Pygoderma bilabiatum* described for the eastern and western forest segments (Owen and Webster, 1983) suggest that the chaco might be contributing to the differentiation of species by acting as a wide barrier between eastern and western humid forests.

The many changes that have occurred in the composition and distribution of the aridlands mammalian faunas may relate to vegetational changes during the Tertiary, especially during the period floristically defined as the Chaco-Tertiary Paleoflora (Solbrig, 1976). During the late Tertiary, the Andean uplift resulted in an increase of desertification. This was accompanied by the appearance in the fossil record of groups such as *Abrocoma*, *Ctenomys*, and caviids that are associated with a treeless, semidesert-steppe (Pascual and Rivas, 1971; Patterson and Pascual, 1972; Webb, 1978). In the late Miocene and Pliocene, the pre-Andean and Pampean mountain ranges of northwestern Argentina appeared, creating xeric intermontane valleys (Harrington, 1962; Simpson, 1979; Simpson and Vervoort, 1977; Vuilleumier, 1971), such as the present Monte Desert. Farther south, this orogenic activity created the Patagonian steppe. A series of glacial and interglacial periods characterized the Pleistocene. During this period, the Monte Desert was at times restricted to isolated pockets surrounded in part by glaciers and a lake that extended across central Argentina to the Atlantic Ocean (Tapia, 1935; Vuilleumier, 1971). The area covered by this lake coincides today with a wide ecotonal area between the monte and chaco vegetation (Morello, 1958). The disjunct distributions of genera such as *Chlamyphorus* (Edentata) and *Andalgalomys* (Rodentia) reflect these vicariant events. *Chlamyphorus truncatus* and *Andalgalomys*

olrogi now are restricted to the central monte, and *C. retusus* and *A. pearsoni* are restricted to the Gran Chaco region (Myers, 1977; Williams and Mares, 1978; Yepes, 1929, 1939). Other monte endemics are *Octomys mimax* and *Tympanoctomys barrerae*, the present geographic ranges of which may reflect Pleistocene refugia in the monte (Mares, 1973, 1985).

Differences in taxonomic composition reflect distinct ecological strategies. Our analyses of Salta mammals show some of the same latitudinal patterns described by others for mammals along a temperate-tropical gradient (Fleming, 1973; McCoy and Connor, 1980; Simpson, 1964; Wilson, 1974). In northwestern Argentina, the increase in elevation from east to west is accompanied by decreasing mean annual temperatures, which vary from 23°C in the lower elevations to 10°C in the puna, roughly equivalent to the temperature gradient accompanying latitudinal changes from equatorial to temperate regions. This general equivalency is illustrated by the lowland presence in the Patagonian steppe of many species that are limited to the highlands farther north. The same pattern is seen on mountain tops at equatorial latitudes (MacArthur, 1972). The percentages of species that are terrestrial and herbivorous increase at higher elevations and the numbers of species of volant taxa and of occupied niches increase at lower elevations.

The small number of species in the monte and the lack of morphoecological and physiological adaptations to this desert have been attributed to slow colonization of this isolated region and to slow evolutionary adaptation to aridity by animals derived from more mesic areas (Mares, 1975, 1976, 1980, 1985). Interestingly, the terrestrial anteater (*Myrmecophaga tridactyla*) reaches its westernmost distribution near Santa Bárbara. This area has been defined floristically as an ecotone between the monte and chaco (Morello, 1958). These northwestern valleys (today's monte region) might have acted as corridors for subtropical elements during the late Tertiary (Pascual and Rivas, 1971). The presence of fossil tropical trees and mammals such as *Lutreolina*, *Myrmecophaga*, echimyids, the erethizontid *Neosteiromys*, and dinomyids along these valleys, suggest a landscape and climate different from today (Marshall and Patterson, 1981). The record of *Myrmecophaga* from Santa Bárbara may be a relict of a once longer and more humid corridor in this area. A comparison (Mares, 1985) of Tertiary and present mammalian faunas in the monte shows no evidence of competitive replacement by the animals that arrived after the completion of the Panamá bridge, although there is a marked reduction in species and types of macroniches occupied.

No myrmecophagous mammal occupied the northern monte. However, portions of the central monte are occupied by the greater fairy armadillo, *Chlamyphorus truncatus*, an insectivore-omnivore. The pre-Andean and Pampean ranges may act as barriers to precipitation, making the northern monte drier than the central monte or chaco. Minoprio (1945) defined the limits of dispersal of *Chlamyphorus truncatus* within a zone of average rainfall of 350 to 400 millimeters per year. In the northern monte of Salta

Province, an average of 228 millimeters per year is reported for the locality of Cafayate (Morello, 1958).

Chacoan species exploit seasonal resources during a short period of time, have high reproductive rates, and undergo population fluctuations and local migrations during extended periods of drought (Myers, 1982; Ojeda and Barquez, 1976). Some of these adaptations have been reported by Bourlière and Hadley (1983). Insectivorous and myrmecophagous feeding is of major importance. The richness of the insect resource base has been documented extensively by Bucher (1974, 1982). Mammalian myrmecophagy occurs in every major faunal region of the world (Eisenberg, 1981). The five myrmecophagous species recognized in this analysis, *Myrmecophaga tridactyla*, *Tamandua tetradactyla*, *Priodontes maximus*, *Tolypeutes matacus*, and *Chlamyphorus retusa*, coexist within the chaco assemblage. Division of the ant and termite resources might be attainable through use of different substrates by different species, from fossorial and semifossorial to terrestrial and arboreal. Among volant species, there are many insectivores. Differences in foraging height, time of activity, and size of prey might distinguish the aerial insectivores (Fleming *et al.*, 1972).

In regard to the forest fauna, the southern limits of distribution of several families and orders (for example, primates, and lagomorphs to a lesser extent) coincide with a gradual narrowing and fragmentation of forest habitat (Fig. 9). Along its extension in northwestern Argentina of approximately 685 kilometers, to its southernmost range in the provinces of Tucumán and Catamarca (28° 40'), the number of species declines by about 58 percent (based on more than 100 locality records for Tucumán Province). Explanations involving faunal equilibria, peninsular effects, island-area versus number of species, and so forth are confounded by other factors, such as vegetational impoverishment, increasing seasonality and human perturbation (Cabrera, 1976; Meyer, 1963; Vervoort, 1982). However, it is not difficult to visualize the "Yungas" forest as a long and narrow peninsula exhibiting a loss of biotic elements as the distance from the source area (Bolivia) increases. This is observed in approximately 13 species of bats of New World families (see Koopman, 1982). Bat species frequently decrease in number as the latitude increases, however, and in the extension of the "Yungas" in northern Argentina, there is an increase of 6° latitude from the border with Bolivia to the southernmost tip of the forest at 28° south latitude.

As noted above, the forest peninsula in northwestern Argentina is divided into two parts. The distance between the contiguous forest and the isolated southern fragment is no greater than 50 kilometers. These two forest zones are separated by the rivers Guachipas-Juramento and San Francisco, but by no other appreciable barriers. The forest of the southern block, except for the absence of certain plant species, has the same structural complexity (number of strata, life forms), and receives more precipitation than the northern block (Meyer, 1963). The fact that many bats and other species

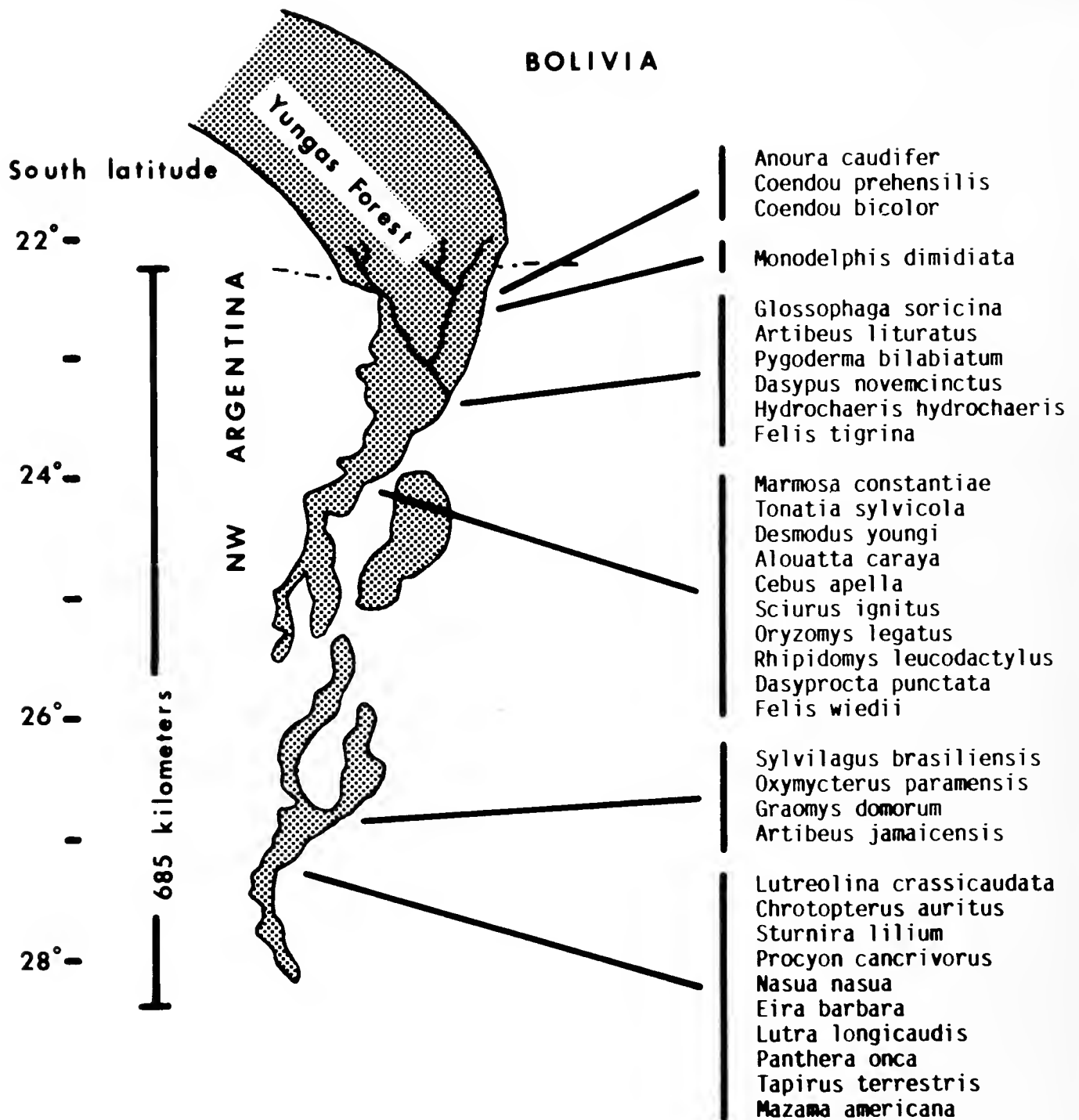

FIG. 9.—Southern limits of distribution of mammal species associated with the Yungas forest. *Coendou bicolor* has not yet been verified for Salta, but C. C. Orog (personal communication) felt that both *Coendou* species are present in the province. *Tapirus* and *Panthera* have recently been extirpated from the southern Yungas forest.

with high capability of dispersal (six species of bats; Rabinovich and Rapaport, 1975, reported on this decreasing pattern for birds) are absent from the southern forest fragment, suggests that other causes might be involved. Temperatures may drop to -5°C on some days in June and August in the southernmost portions of the forest corridor, and this seems to be one obstacle to the expansion of tropical species to this southern forested block. Some ant colonies of northern origin take between four and six years to recover after they become locally extinct during a cold winter (Meyer and Weyrauch, 1966). Analyzing the mammals that range as far

south as 28° latitude, we observe the disappearance of several arboreal species that have frugivorous or granivorous diets, as well as volant nectarivores. Another vacant cell in the niche matrix of Table 7 in the southern forest fragment is the foliage-gleaning insectivore (filled by *Tonatia sylvicola* in the northern forest). The nectar-feeders are primarily tropical because only in the tropics are nectar and pollen available throughout the year. The southern limits of *Glossophaga* and *Anoura* (Koopman, 1981) in Salta Province, reflect this change of seasonality between these forested fragments, the northern forest having a more equitable climate.

Arboreality and the use of fruits and seeds are consistently correlated in tropical regions (Glanz, 1982; Eisenberg *et al.*, 1979). Glanz *et al.* (1982) have suggested that a failure in the fruit production could be associated with an increase in mortality in squirrels, *Sciurus granatensis*, if no other appropriate food is available. Glanz (1982) reported that some trees, such as *Ficus* (figs), have extremely large seed crops and attract at least 15 species of nonvolant mammals in the tropical area of Barro Colorado in Panamá. Among the mammal species associated with figs that are listed by Glanz are *Alouatta*, *Cebus*, *Sciurus*, and *Dasyprocta*. Hiethaus *et al.* (1975) emphasized the importance of figs for bats and suggested that bats and figs are mutualists. It is highly suggestive that the southern limits of the mammal genera listed by Glanz (1982) coincide with the southern limits of the genus *Ficus* in Argentina (Cabrera, 1976). Although these frugivores eat several other fruits and seeds besides figs, the impoverishment of the vegetation (loss of key resources) and increase in seasonality seem a plausible hypothesis for the reduction of some tropical elements in the moist forests of northwestern Argentina. Reduction in size of forested areas and hunting pressures both contribute to the rarefaction of a number of economically important species (Mares and Ojeda, 1984; Ojeda and Mares, 1982, 1984), and the effects of habitat modification in forest areas cannot be discounted as possibly having substantive negative effects on mammal distribution patterns in the region.

SUMMARY

Northwestern Argentina has been recognized by different authors as a transitional zone between the Brazilian and Patagonian Neotropical subregions, but no detailed analysis has been made of a major taxon within the region. Mammals of Salta Province were analyzed from both a biogeographical and ecological perspective in an attempt to characterize faunal composition and species richness, the degree of resemblance among the mammalian assemblages, and trends in functional (macroniche) diversity.

One hundred and twelve species, 78 genera, 28 families, and nine orders are contained within Salta's area of 155,000 square kilometers. The number of mammalian taxa declines as aridity and altitude increase in the western portions of the province. Thus, in the high, arid Andean Plateau, five orders that are present in other parts of the province are absent. The transitional forest is the richest macrohabitat, whereas the upper montane and prepuna show a reduced density of species. Seven families reach their southwestern limits of distribution along the lower montane-transitional forest corridor. Among bats, an increase in number of species is observed toward lower altitudes, and a marked shift in their taxonomic composition occurs along the lower montane-chaco macrohabitats.

Analyses of resemblance between these mammalian assemblages at different taxonomic levels result in two major clusters, the "aridlands" and "forests" faunas. The "aridlands" mammals grade from the semiarid lowland chaco assemblage, through the monte, to the highlands assemblage (above 2500 meters). The "forests" fauna comprises the lower montane and transitional assemblages along the "Yungas" vegetational province.

The distinctiveness of these assemblages coincides with abrupt changes in topographic and environmental features. The Andean Plateau and highlands in general are dominated by Patagonian elements, whereas the lowlands show a gradual incorporation of Brazilian species, especially along the chaco-lower montane segment. The similarity of the results found for the "aridlands" mammals and those found for the dry plant formations, in terms of resemblance, suggest similar evolutionary histories during the Tertiary and Quaternary.

The gradients in the mammalian assemblages of Salta Province not only reflect a different taxonomic composition between areas, but distinctive adaptive patterns as well. A functional approach, related to macroniche space occupancy, shows increasing richness from the highlands assemblage to faunas inhabiting lower elevations. Subdivision of the macroniche space into its two-dimensional components, substrate and feeding, reveals marked differences among "aridlands" and "forests" mammals. A trend toward an increasing proportion of terrestrial species is found from the lowland forests to the semiarid and high altitude habitats. An inverse trend is observed in the volant, scansorial, and arboreal dimensions. Fossorial and semifossorial adaptations tend to increase toward the semiarid thorn scrub, chaco

macrohabitat. Among the feeding categories, the distribution of frugivorous, nectarivorous, and herbivorous species is markedly different between “forests” and “aridlands” faunas. Macroniche diversity seems to correlate well with different environmental parameters, such as degree of seasonality, habitat heterogeneity, precipitation, and elevation.

The highest macroniche diversity and equitability are observed in the lower montane assemblage. This association also shows a low species packing index. The lowest diversity is found in the monte assemblage. Significant differences in macroniche diversity were found between the lower montane and aridland components (highlands, monte, and chaco assemblages). The highlands assemblage, whereas appearing to be a simple community, shows a well-segregated macroniche space. At the other extreme of the gradient, in the “Yungas” forest, a marked drop in species richness is observed. A combination of factors, such as increased seasonality, vegetational impoverishment, and habitat perturbation, appear to restrict the southern dispersion of tropical species.

ACKNOWLEDGMENTS

Many people have influenced our research in Salta. We thank the late Dr. Claes Olrog, who opened the path and showed us the way. Ruben Barquez assisted us on many field trips and made available unpublished material on Salta. M. R. Willig, G. D. Schnell, R. J. Raikow, H. H. Genoways, R. Hartman, J. Schwartz and, especially, an anonymous reviewer, read earlier versions of the manuscript. For help in the field and laboratory we thank J. Cajal, J. K. Braun, L. B. Mares, D. Hough, R. Macedo, K. Ernest, L. Nitikman and S. Johnson. Technical support was provided by the Consejo Nacional de Investigaciones Científicas y Técnicas (CONICET), Instituto Argentino de Investigaciones de Zonas Áridas (IADIZA), the Fulbright Foundation (CIES), the University of Oklahoma Biological Survey and Oklahoma Museum of Natural History, and the Carnegie Museum of Natural History. Finally, we thank the curators of the collections utilized in this research: S. Anderson, K. F. Koopman, H. H. Genoways, C. Olrog, B. Patterson, J. Crespo, and J. E. Hill.

GAZETTEER OF LOCALITIES

1. Abra de Acay — 24°33', 66°16'
2. Agua Linda — 23°17', 63°21'
3. Aguaray — 22°16', 63°44'
4. Agua Salada, Río San Francisco, Jujuy Province — 23°49', 64°36'
5. Aguas Blancas — 22°44', 64°28'
6. 20 km. NW Aguas Blancas, Vado de Arrayazal — 22°29', 64°39'
7. 24 km. NW Aguas Blancas — 22°29', 64°39'
8. Aguas Chiquitas, 4 km. NE Fishery Station, El Cadillal, Tucumán Province — 26°37', 65°12'
9. Alemania — 25°36', 65°38'
10. Angostura — 22°12', 63°38' (= La Angostura)
11. Anta — 24°55', 64°28'
12. 11 km. N Anta, on El Piquete Rd. — 26°50', 64°28'
13. 21 km. N Anta, on El Piquete Rd. — 24°46', 64°28'
14. Arroyo del Diablo, Urundel — 23°28', 64°34'
15. Cachi — 25°06', 66°11'
16. Near Cachi — 25°06', 66°11'
17. 30 km. E Cachi (2600 m.) — 25°09', 66°10'
18. 35 km. E Cachi (3000 m.) — 25°09', 66°10'
19. 30 km. S Cachi, along Hwy. 40 — 25°18', 66°15'
20. Cafayate and Finca La Rosa (2000 m.) — 26°05', 65°58'
21. 6 km. and 8.2 km. NE Cafayate, along Hwy. 68 — 26°05', 65°56'
22. 14 km. NE Cafayate, along Hwy. 68 — 26°05', 65°52'
23. 4 km. W Cafayate, Cueva del Indio — 26°05', 65°58'
24. 5 km. W Cafayate, Yacochuya — 26°05', 65°58'
25. Cabimonte — 25°07', 65°26'
26. Campo Durán — 22°14', 63°42'
27. 8.4 km. E Campo Durán — 22°14', 63°40'
- 27a. Campo Santo — 24°40', 65°06'
28. Capital, Salta — 24°47', 65°25'
29. 28 km. SSE Salta, Finca La Cruz — 24°54', 65°10'
30. 30 km. NE Salta — 24°42', 65°10'
31. Cañada La Matanza — 23°18', 63°22' (= La Matanza)
32. Cañada Mendoza — 23°11', 63°32'
33. 3 km. N Ceibalito — 25°05', 64°19'
34. 3.7 km. N Ceibalito, and jct. of Anta Rd., and Hwy. 16 — 25°05', 64°19'
35. Cerrillos, INTA Station — 24°54', 65°29'
36. Cerro Aguaray — 22°16', 63°44'
37. Cerro Capiazuti — 22°11', 63°47'
38. 6 km. SSW Chicoana, Toma de Los Laureles (1400 m.) — 25°09', 65°35'
39. Chorrillos — 24°45', 65°45'
40. Chorrillos (4000-4500 m.) — 24°13', 66°27'
41. Ciénagas, junta de Ríos Medina y Juramento — 25°16', 64°28'
- 41a. Coronel Cornejo — 22°44', 63°50'
42. Departamento de San Carlos — 25°45', 66°05'
- 42a. Departamento Metán — 25°30', 64°40'
43. 5 km. W Dique Itiyuro — 22°23', 63°32'
44. 17 km. SW Dique Itiyuro — 22°21', 63°59'
45. Dragones — 23°15', 63°21'
46. 15 km. SE Dragones — 23°19', 63°13'
47. El Arenal (Anta) — 25°09', 64°03' (= Arenal)
48. El Cadillal, Fishery Station, 25 km. N Tucumán, Tucumán Province — 26°37', 65°12'
49. El Infiernillo, Tafí del Valle, Tucumán Province — 26°49', 65°38'
50. El Quebrachal — 25°17', 64°04'
51. El Simbolar, 25 km. SW Palma Solá, Jujuy Province — 24°11', 64°28'
52. El Tala — 26°07', 65°17'
- 52a. Embarcación — 23°13', 64°06'
53. Gavilán Pozo, 60 km. NE Joaquín V. Gonzalez — 24°54', 63°35'
54. 20 km. W General Ballivián, on Puerto Baulés Rd. — 22°50', 64°00'
55. General Guemes (734 m.) — 24°40', 65°03' (= Guemes)
56. 25 km. E General Guemes — 24°50', 64°46' (= Unchimé; Mina Pablo)
57. 30 km. SSW General Guemes — 24°47', 65°06'
- 57a. Gobernador Manuel Solá (2500 m.) — 24°34', 65°50' (= G. M. Solá)
58. Guachipas (1500 m.) — 25°31', 65°32'
59. Hickman — 23°12', 63°34'
60. Horco Molle, 17 km. NW Tucumán, Tucumán Province — 26°47', 65°23'

- 60a. Inca Mayo — 24°36', 65°44'
61. Itaú — 22°17', 64°02'
62. 5 km. W Jollín — 22°08', 63°24'
63. Junta Ríos Medina y Juramento — 25°16', 64°28'
64. Junta Río Tarija (includes Juntas de San Antonio and 2 km. S Juntas de San Antonio as well as Junta de Río Tarija y Río Bermejo) — 22°51', 64°20'
65. Laguna Blanca (3200 m.), Catamarca Province — 26°40', 67°30'
66. Laguna Brava (3760 m.), La Rioja Province — 28°30', 69°00'
67. Laguna de Las Catas, Tartagal — 22°16', 63°52'
68. Laguna de Los Panzones, Retiro — 22°54', 63°27'
- 68a. La Cañada, Metán — not exactly located (general vicinity of 25°29', 64°57')
69. La Merced (1200 m.) — 24°58', 65°29'
70. La Poma — 24°43', 66°13'
71. 3 km. S jct. hwy. 40 and 51, along hwy. 40 (4000 m.), La Poma — 24°14', 66°19'
72. 14 km. S jct. hwy. 40 and 51, along hwy. 40 (4100 m.), La Poma — 24°20', 66°19'
73. 18 km. S jct. hwy. 40 and 51, along hwy. 40 (4100 m.), La Poma — 24°25', 66°19'
74. La Represa (Metán) — 25°24', 65°36'
75. Las Juntas — 23°07', 64°33' (= La Junta)
76. Las Lajitas — 24°41', 64°15'
77. Las Palmitas — 23°02', 63°37'
78. Las Víboras — 25°02', 64°39'
79. La Unión — 23°53', 63°10'
80. Los Andes (3000 m.) — 24°30', 67°20'
81. Los Blancos — 23°36', 62°36'
82. Los Toldos — 22°24', 64°44'
- 82a. Lumbreira — 25°12', 64°55' (= Lumbreiras)
83. Luna Muerta — 23°20', 63°40'
84. Macapillo — 25°22', 64°01'
85. Madrejones — 22°18', 64°09' (= Los Madrejones)
86. Manuel Elordi — 23°16', 64°08'
- 86a. Manuela Pedraza — 27°14', 65°21'
87. Metán — 25°29', 64°57'
88. Molinos — 25°25', 66°19'
- 88a. Murillo — not exactly located
89. Ñacuñán, Mendoza Province — 34°03', 67°58'
90. Orán — 23°08', 64°20' (= Santa Orán)
91. 35 km. E Orán — 23°08', 63°57'
92. 22 km. SW Orán, along Río Santa María — 23°17', 64°14'
93. 15 km. SW Orán, along Río Santa María — 23°17', 64°14'
94. Palma Solá, Jujuy Province — 23°59', 64°18'
95. Pampa Grande — 25°50', 65°30'
96. 20 km. S Pampa Grande, along Hwy. 9 — 25°57', 65°32'
97. Parque El Rey — 24°42', 64°38'
98. Pichanal — 23°19', 64°13'
- 98a. Piquirenda Viejo (Departamento San Martín) — 22°20', 63°47'
99. Playa Ancha — 22°07', 63°44'
100. 4 km. S Pocoy — 22°45', 64°00'
101. Pozo Hondo — 23°46', 63°23'
102. Quebrada de Acambuco — 22°21', 63°59'
103. Quebrada de Escoipe, Cerro Candadito — 25°14', 65°48'
104. Quebrada de San Lorenzo — 24°43', 65°29'
105. Quebrada de Tartagal, Finca Abra Grande — 22°40', 63°41'
106. Retiro — 22°54', 63°27'
107. Río Blanco (1600 m.), 35 km. SW Salta — 24°57', 65°58'
108. Río Blanco — 23°17', 64°56'
109. Río Cachi — 26°03', 65°50'
110. Río Caraparí — 22°08', 63°43'
111. Río Colorado — 23°17', 64°44'
112. Río del Valle — 24°38', 64°15'
113. Río Juramento — 25°35', 63°57'
114. Río Mojotoro, 5 km. N Salta — 24°44', 65°00'
115. Río Pescado, Orán — 22°53', 64°27'
- 115a. Río Piedras — 25°18', 64°54'
116. Río Pilcomayo (at the border with Paraguay and Bolivia) — 22°14', 62°42'
117. Río Santa María — 23°17', 64°14'
118. Rivadavia — 24°11', 62°53'
119. Rosario de La Frontera — 25°48', 64°58'
120. 15 km. E Rosario de La Frontera — 25°48', 64°48'
121. Rosario de Lerma (1600 m.) — 24°59', 65°35'
122. Ruiz de Los Llanos — 26°07', 65°17' Salta (see Capital, Salta)
123. San Antonio de Los Cobres (3700 m.) — 24°11', 66°21'
124. San Francisco — 24°57', 65°16'

125. San Guillermo Reserve (3100-4200 m.),
San Juan Province — 29°10', 69°20'
126. Santa Bárbara — 25°56', 65°45'
127. Santa María W — 23°17', 64°14'
128. 1 km. and 2 km. W Santa María E —
23°17', 64°14'
129. Santa María E — 22°08', 62°49'
130. Santa Victoria E — 22°16', 62°42'
131. 4 km. NE Santa Victoria E — 22°15',
62°42'
132. 6 km. SW Santa Victoria E, at "El
Breal" — 23°14', 62°56'
133. Santa Victoria W — 22°15', 64°58'
134. Seclantás — 25°18', 66°15'
- 134a. Sierra de Zenta (Jujuy Province) —
23°03', 65°05'
135. Socompa — 24°33', 68°11'
136. Tabacal — 23°16', 64°15' (= El Tabacal)
137. Tartagal — 22°32', 63°49'
138. 27 km. E Tartagal, along Tonono Rd.
— 22°25', 63°38'
139. 30 km. N Tartagal — 22°16', 63°44'
140. 5 km. S Tolloche, on Vinalito Rd. —
25°30', 63°32'
141. 4 km. S Tolombón, along Hwy. 40 —
26°15', 65°58' (= 8 km. N La Viñita)
142. 15 km. N Tucumán, Tucumán Pro-
vince — 26°44', 65°13'
Unchimé, Mina Pablo (= 25 km. E
General Guemes)
143. Urundel-El Bananal — 23°33', 64°25'
144. Valle de Lerma (1200 m.) — 25°20',
65°26'
145. Vespucio — 22°37', 63°49'
146. Yacimiento Tonono — 22°24', 63°29'
147. Yuto, Jujuy Province — 23°38', 64°28'
148. Zuviría — 25°05', 65°29'

LITERATURE CITED

- ADÁMOLI, J., R. NEUMANN, A. R. DECOLINA, AND J. MORELLO. 1972. El chaco aluvional salteño (convenio INTA-Provincia de Salta). *Rev. Invest. Agróp.*, INTA, Bs. As., ser. 3, 9:165-237.
- ALLEN, J. A. 1901. New South American Muridae and a new *Metachirus*. *Bull. Amer. Mus. Nat. Hist.*, 14:405-412.
- AMEGHINO, C. 1909. Una nueva especie de tapir: (*Tapirus spegazzinii* n. sp.). *Anal. Mus. Nac. Buenos Aires*, 20:31.
- ANDERSON, S., AND J. K. JONES, JR. (eds.). 1967. Recent mammals of the world: a synopsis of families. Ronald Press, New York, viii + 453 pp.
- . 1984. Orders and families of Recent mammals of the world. Wiley-Interscience Press, xii + 686 pp.
- ANDERSON, S., K. F. KOOPMAN, AND G. K. CREIGHTON. 1982. Bats of Bolivia: an annotated checklist. *Amer. Mus. Novit.*, 2750:1-24.
- AUGUST, P. V. 1983. The role of habitat complexity and heterogeneity in structuring tropical mammal communities. *Ecology*, 64:1495-1505.
- BAKER, R. J., AND H. H. GENOWAYS. 1978. Zoogeography of Antillean bats. Pp. 53-97, in *Zoogeography in the Caribbean* (F. B. Gill, ed.), Acad. Nat. Sci. Philadelphia, Spec. Publ., 13:iii + 1-128.
- BARQUEZ, R. M. 1976. Un nuevo registro de *Oxymycterus paramensis* en Argentina. *Neotrópica*, 22:137.
- . 1984a. Morfometría y comentarios sobre la colección de murciélagos de la Fundación Miguel Lillo (familias Emballonuridae, Noctilionidae, Mormoopidae, Phyllostomidae, Furipteridae, Thyropteridae) (Mammalia, Chiroptera). *Hist. Natur.*, 3:213-223.
- . 1984b. Significativa extensión del rango de distribución de *Diaemus youngii* (Jentink, 1893) (Mammalia, Chiroptera, Phyllostomidae). *Hist. Natur.*, 4:67-68.
- . 1985. *Glossophaga soricina* (Pallas, 1766) en el noroeste Argentino (Chiroptera:Phyllostomidae). *Hist. Natur.*, 5:93-96.
- BARQUEZ, R. M., AND S. I. GUERRERO. 1985. *Chrotopterus auritus* (Peters, 1856), nueva especie para la provincia de Tucumán, Argentina (Mammalia:Chiroptera:Phyllostomidae). *Hist. Natur.*, 5:29-32.
- BARQUEZ, R. M., AND R. A. OJEDA. 1975. *Tadarida laticaudata*, un nuevo molósido para la fauna Argentina (Chiroptera, Molossidae). *Neotrópica*, 21:137-138.
- BARQUEZ, R. M., AND C. C. OLROG. 1985. *Anoura caudifer* (Geoffroy, 1818) nueva especie de murciélago para la Argentina (Phyllostomidae: Glossophaginae). *Hist. Natur.*, 5:149-152.
- BARQUEZ, R. M., D. F. WILLIAMS, M. A. MARES, AND H. H. GENOWAYS. 1980. Karyology and morphometrics of three species of *Akodon* (Mammalia: Muridae) from northwestern Argentina. *Ann. Carnegie Mus.*, 49:379-403.
- BEALS, E. W. 1969. Vegetational change along altitudinal gradients. *Science*, 165:981-985.
- BOURLIÈRE, F., AND M. HADLEY. 1983. Present-day savannas: an overview. Pp. 1-17, in *Ecosystems of the world 13: tropical savannas* (F. Bourliere, ed.), Elsevier, The Netherlands, 730 pp.
- BROWN, J. H. 1981. Two decades of homage to Santa Rosalia: toward a general theory of diversity. *Amer. Zool.*, 21:877-888.
- BUCHER, E. H. 1974. Observaciones ecológicas sobre los artrópodos del bosque chaqueño de Tucumán. *Rev. Fac. Cs. Exact., Fis. Natur.*, Córdoba, Biología, 1:35-122.
- . 1982. Chaco and Caatinga—South American arid savannas, woodlands and thickets. Pp. 48-79, in *Ecology of tropical savannas* (B. J. Huntley and B. H. Walker, eds.), Ecological studies, vol. 42, Springer-Verlag Berlin, Heidelberg, 669 pp.
- CABRERA, A. 1953. Los roedores Argentinos de la familia Cavidae. *Fac. Agron. Vet. Univ. Buenos Aires*, Publ. no. 6, 93 pp.
- . 1957. Catálogo de los mamíferos de América del Sur. I. (Metatheria-Unguiculata-Carnivora). *Rev. Mus. Argentino Cien. Nat. "Bernardino Rivadavia."* Zool., 4:1-307.

- . 1961. Catálogo de los mamíferos de América del Sur II. (Sirenia-Perissodactyla-Artiodactyla-Lagomorpha-Rodentia-Cetacea). Rev. Mus. Argentino Cien. Nat. "Bernardino Rivadavia," Zool., 4:309-732.
- CABRERA, A., AND J. YEPES. 1960. Mamíferos Sud Americanos. Historia Natural Ediar, Buenos Aires, T. 1, 187 pp.
- CABRERA, A. L. 1957. La vegetación de la Puna Argentina. Rev. Investig. Agric., Buenos Aires, 370 pp.
- . 1971. Fitogeografía de la República Argentina. Bol. Soc. Arg. Bot., 14:1-42.
- . 1976. Regiones fitogeográficas Argentinas. Encicl. Arg. Agric. Jard. T. 1, fasc. 1:1-85.
- CABRERA, A. L., AND A. WILLINK. 1973. Biogeografía de América Latina. OEA, Ser. Biol., Monogr. no. 13, Washington, D.C., 117 pp.
- CAJAL, J. L. 1981. Estudios preliminares sobre el área de acción en marsupiales (Mammalia, Marsupialia). Physis, 40:27-37.
- . 1983. Situación del guanaco en la República Argentina. Pp. 3-21, in Situación del guanaco y estrategia de la conservación de los camélidos en la Argentina. Subsec. Cien. Tec. Buenos Aires, Argentina, 31 pp.
- CAJAL, J. L., N. E. LOPEZ, A. RECA, AND J. C. PUJALTE. 1983. La estrategia de la conservación de los camélidos en Argentina con especial referencia a la vicuña. Pp. 23-31, in Situación del guanaco y estrategia de la conservación de los camélidos en la Argentina, Subsec. Cien. Tec., Buenos Aires, Argentina, 31 pp.
- CARLEVARI, I. J. F. 1976. La Argentina: geografía humana y económica. Ed. ERGON, 5 ed., Buenos Aires, 476 pp.
- CERQUEIRA, R. 1982. South American landscapes and their mammals. Pp. 53-75, in Mammalian biology in South America (M. A. Mares and H. H. Genoways, eds.), Pymatuning Lab. Ecol. Spec. Publ., 6:xii + 1-539.
- CONTRERAS, J. R. 1979. Lista faunística preliminar de los vertebrados de la reserva ecológica de Nacuñán. IADIZA, Mendoza, Argentina, Cuaderno Técnico, 79:39-47.
- CRESPO, J. A. 1958. Nuevas especies y localidades de quirópteros para Argentina (Mammalia, Chiroptera). Neotrópica, 4:27-32.
- . 1964. Dos mamíferos nuevos para la provincia de Córdoba. Neotrópica, 10:62.
- . 1971. Ecología del zorro gris *Dusicyon gymnocercus antiquus* (Ameghino) en la Provincia de la Pampa. Rev. Mus. Argentino Cien. Nat. "Bernardino Rivadavia," Ecol., 1:147-205.
- . 1974. Comentarios sobre nuevas localidades para mamíferos de Argentina y Bolivia. Rev. Mus. Argentino Cien. Nat. "Bernardino Rivadavia," Zool., 11:1-31.
- . 1982. Ecología de la comunidad de mamíferos del Parque Nacional Iguazú, Misiones. Rev. Mus. Argentino Cien. Nat. "Bernardino Rivadavia," Ecol., 3:1-161.
- DAVIS, W. B. 1970. The large fruit bats of Middle America (genus *Artibeus*) with a review of the *Artibeus jamaicensis* complex. J. Mamm., 51:105-122.
- DEFINA, A. L. 1974. El clima de la República Argentina. Encicl. Arg. Agric. Jard. T. 1, fasc. 2:87-104.
- EGER, J. L. 1977. Systematics of the genus *Eumops* (Chiroptera: Molossidae). Life Sci. Contrib., Royal Ontario Mus., 110:1-69.
- EISENBERG, J. F. 1980. The density and biomass of tropical mammals. Pp. 35-55, in Conservation biology: an evolutionary-ecological perspective (M. Soulé and B. A. Wilcox, eds.), Sinauer Press, Sunderland, Massachusetts, 395 pp.
- . 1981. The mammalian radiations. An analysis of trends in evolution, adaptation, and behavior. Univ. Chicago Press, xx + 610 pp.
- EISENBERG, J. F., M. A. O'CONNELL, AND P. V. AUGUST. 1979. Density, productivity and distribution of mammals in two Venezuelan habitats. Pp. 187-207, in Vertebrate ecology in the northern Neotropics (J. F. Eisenberg, ed.), Smithsonian Inst. Press, Washington, D.C., 271 pp.
- EISENBERG, J. F., AND K. H. REDFORD. 1982. Comparative niche structure and evolution of mammals of the Nearctic and southern South America. Pp. 77-84, in Mammalian

- biology in South America (M. A. Mares and H. H. Genoways, eds.), Pymatuning Lab. Ecol. Spec. Publ., 6:xii + 1-539.
- EISENBERG, J. F., AND R. W. THORINGTON, JR. 1973. A preliminary analysis of a Neotropical mammal fauna. *Biotropica*, 5:150-161.
- FIGUEROA, F. R. 1977. Historia de Salta. Colección: historia de nuestras provincias. Ed. Plus Ultra, Buenos Aires, 231 pp.
- FITTKAU, E. J. 1969. The fauna of South America. Pp. 624-657, in *Biogeography and ecology in South America* (E. J. Fittkau, J. Illies, H. Klinge, G. H. Schwabe, and H. Sioli, eds.), Dr. W. Junk Publ., The Hague, 946 pp.
- FLEMING, T. H. 1973. Numbers of mammal species in North and Central American forest communities. *Ecology*, 54:555-563.
- FLEMING, T. H., E. T. HOOPER, AND D. E. WILSON. 1972. Three Central American bat communities: structure, reproductive cycles, and movement patterns. *Ecology*, 53:555-569.
- FORNES, A., AND E. MASSOIA. 1967. Procedencias argentinas nuevas o poco conocidas para murciélagos (Noctilionidae, Phyllostomatidae, Vespertilionidae y Molossidae). *Serv. Jorn. Entomoepid. Arg.* 1, (1965) 1967:133-145.
- FRANKLIN, W. L. 1982. Biology, ecology, and relationship to man of the South American camelids. Pp. 457-490, in *Mammalian biology in South America* (M. A. Mares and H. H. Genoways, eds.), Pymatuning Lab. Ecol. Spec. Publ., 6:xii + 539.
- GLANZ, W. E. 1982. Adaptive zones of neotropical mammals: a comparison of some temperate and tropical patterns. Pp. 95-110, in *Mammalian biology in South America* (M. A. Mares and H. H. Genoways, eds.), Pymatuning Lab. Ecol. Spec. Publ., 6:xii + 539.
- GLANZ, W. E., R. W. THORINGTON, JR., J. GIACALONE-MADDEN, AND L. R. HEANEY. 1982. Seasonal food use and demographic trends in *Sciurus*. Pp. 239-252, in *The ecology of a tropical forest: seasonal rhythms and long-term changes* (E. G. Leigh, Jr., A. S. Rand, and D. M. Windsor, eds.), Smithsonian Inst. Press, Washington, D.C., 468 pp.
- GRANT, W. E., AND E. C. BIRNEY. 1979. Small mammal community structure in North American grasslands. *J. Mamm.*, 60:23-36.
- HARRINGTON, H. 1962. Paleogeographic development of South America. *Bull. Amer. Assoc. Petrol. Geol.*, 46:1773-1814.
- HAWKES, J. G., AND J. P. HJERTING. 1969. The potatoes of Argentina, Brazil, Paraguay, and Uruguay. *Ann. Bot. Mem.*, Oxford, 3:33-47.
- HEITHAUS, E. R., T. H. FLEMING, AND P. A. OPLER. 1975. Foraging patterns and resource utilization in 7 spp. of bats in a seasonal tropical forest. *Ecology*, 56:841-854.
- HERSHKOVITZ, P. 1958. A geographic classification of neotropical mammals. *Fieldiana Zool.*, 36:581-620.
- . 1962. Evolution of neotropical cricetine rodents (Muridae) with special reference to the phyllotine group. *Fieldiana Zool.*, 46:1-524.
- . 1972. The recent mammals of the Neotropical Region: a zoogeographic and ecological review. Pp. 311-431, in *Evolution, mammals, and southern continents* (A. Keast, F. C. Erk, and B. Glass, eds.), State Univ. New York Press, Albany, 543 pp.
- HONACKI, J. H., K. E. KINMAN, AND J. W. KOEPL (eds.). 1982. *Mammal species of the world: a taxonomic and geographic reference*. Assoc. Syst. Collections and Allen Press, Lawrence, Kansas, ix + 694 pp.
- HUMPHREY, S. R., F. J. BONACCORSO, AND T. L. ZINN. 1983. Guild structure of surface-gleaning bats in Panamá. *Ecology*, 64:284-294.
- KEAST, A. 1972. Comparisons of contemporary mammal faunas in southern continents. Pp. 433-501, in *Evolution, mammals, and southern continents* (A. Keast, F. C. Erk, and B. Glass, eds.), State Univ. New York Press, Albany, 543 pp.
- KOOPMAN, K. F. 1976. Zoogeography. Pp. 39-47, in *Biology of bats of the New World family Phyllostomatidae* (R. J. Baker, J. K. Jones, Jr., and D. C. Carter, eds.), Spec. Publ. the Mus., Texas Tech Univ., 10:1-218.

- . 1981. The distributional patterns of New World nectar-feeding bats. *Ann. Missouri Bot. Gard.*, 68:352-369.
- . 1982. Biogeography of the bats of South America. Pp. 273-302, *in* Mammalian biology in South America (M. A. Mares and H. H. Genoways, eds.), Pymatuning Lab. Ecol. Spec. Publ., 6:xii + 1-539.
- LAVAL, R. K. 1973. A revision of the Neotropical bats of the genus *Myotis*. *Sci. Bull., Nat. Hist. Mus. Los Angeles Co.*, 15:1-54.
- LUCERO, M. M. 1983. Lista y distribución de aves y mamíferos de la provincia de Tucumán. *Fund. Miguel Lillo, Misc.*, 75:1-61.
- LLANOS, A. C. 1944. Apreciaciones de campo con motivo de una concentración de roedores en las provincias de Salta y Jujuy. *Rev. Arg. Zoogeogr.*, 4:51-57.
- MABRY, T. J., J. H. HUNZIKER, AND D. R. DIFEO, JR. (eds.). 1977. Creosote bush: biology and chemistry of *Larrea* in New World deserts. Dowden, Hutchinson and Ross, Inc., Stroudsburg, Pennsylvania, 284 pp.
- MACARTHUR, R. H. 1972. Geographical ecology: patterns in the distribution of species. Harper and Row, New York, 269 pp.
- MACMAHON, J. A. 1976. Species and guild similarity of North American desert mammal faunas: a functional analysis of communities. Pp. 133-148, *in* Evolution of desert biota (D. W. Goodall, ed.), Univ. Texas Press, Austin, 250 pp.
- MARES, M. A. 1973. Climates, mammalian communities and desert rodent adaptations: an investigation into evolutionary convergence. Ph.D. dissertation, Univ. Texas, Austin, 345 pp.
- . 1975. Observations of Argentine desert rodent ecology, with emphasis on water relations of *Eligmodontia typus*. Pp. 155-175, *in* Rodents in desert environments (I. Prakash and P. K. Ghosh, eds.), W. Junk Publ., The Hague, 624 pp.
- . 1976. Convergent evolution of desert rodents: multivariate analysis and zoogeographic implications. *Paleobiology*, 2:39-63.
- . 1980. Convergent evolution among desert rodents: a global perspective. *Bull. Carnegie Mus.*, 49:379-403.
- . 1985. The effects of the great American interchange on the mammal faunas of xeric habitats. Pp. 489-520, *in* The great American biotic interchange (F. Stehli and S. D. Webb, eds.), Plenum Press, New York, 532 pp.
- MARES, M. A., J. A. MORELLO, AND G. GOLDSTEIN. 1985a. The Monte Desert and other subtropical semiarid biomes of Argentina, with comments on their relation to North American arid areas. Pp. 203-237, *in* Ecosystems of the world 12A: hot deserts and arid shrublands. (M. Evenari, I. Noy-Meir, and D. W. Goodall, eds.), Elsevier, The Netherlands, 365 pp.
- MARES, M. A., AND R. A. OJEDA. 1982. Patterns of diversity and adaptation in South American hystricognath rodents. Pp. 393-432, *in* Mammalian biology in South America (M. A. Mares and H. H. Genoways, eds.), Pymatuning Lab. Ecol. Spec. Publ., 6:xii + 539.
- . 1984. Faunal commercialization and conservation in South America. *BioScience*, 34:580-584.
- MARES, M., R. OJEDA, AND M. KOSCO. 1981a. Observations on the distribution and ecology of the mammals of Salta Province, Argentina. *Ann. Carnegie Mus.*, 50:151-206.
- MARES, M. A., M. R. WILLIG, K. E. STREILEIN, AND T. E. LACHER, JR. 1981b. The mammals of northeastern Brazil: a preliminary assessment. *Ann. Carnegie Mus.*, 50:80-137.
- MARES, M. A., M. R. WILLIG, AND T. E. LACHER, JR. 1985b. The Brazilian Caatinga in South American zoogeography: tropical mammals in a dry region. *J. Biogeogr.*, 12:57-69.
- MARSHALL, L. G. 1979. A model for paleobiogeography of South American cricetine rodents. *Paleobiology*, 5:126-132.
- . 1981. The Great American Interchange—an invasion induced crisis for South American mammals. Pp. 133-229, *in* Biotic crises in ecological and evolutionary time (M. Nitecki, ed.), Academic Press, New York, 532 pp.

- MARSHALL, L. G., R. F. BUTLER, R. E. DRAKE, G. H. CURTIS, AND R. H. TEDFORD. 1979. Calibration of the Great American Interchange. *Science*, 204:272-279.
- MARSHALL, L. G., AND B. PATTERSON. 1981. Geology and geochronology of the mammal-bearing Tertiary of the Valle de Santa María and Río Corral Quemado, Catamarca Province, Argentina. *Fieldiana Geol.*, 9:1-80.
- MASSOIA, E. 1974. Datos sobre un cricétido nuevo para la Argentina: *Oryzomys (Oryzomys) capito intermedius* y sus diferencias con *Oryzomys (Oryzomys) legatus* (Mammalia-Rodentia). *CICA, Bs. As.*, 309:1-7.
- . 1980. Mammalia de Argentina. I. Los mamíferos silvestres de la Provincia de Misiones. *Iguazú*, 1:15-43.
- MAYER, J. J., AND P. N. BRANDT. 1982. Identity, distribution, and natural history of the peccaries, Tayassuidae. Pp. 433-455, in *Mammalian biology in South America* (M. A. Mares and H. H. Genoway, eds.), Pymatuning Lab. Ecol. Spec. Publ., 6:xii + 1-539.
- MCCOY, E. D., AND E. F. CONNOR. 1980. Latitudinal gradients in the species diversity of North American mammals. *Evolution*, 34:193-203.
- M McNAB, B. K. 1971. The structure of tropical bat faunas. *Ecology*, 52:352-358.
- . 1983. Ecological and behavioral consequences of adaptation to various food resources. Pp. 664-697, in *Advances in the study of mammalian behavior* (J. F. Eisenberg and D. G. Kleiman, eds.), Spec. Publ., Amer. Soc. Mamm. 7:xvi + 1-753.
- MESERVE, P. L., AND W. E. GLANZ. 1978. Geographical ecology of small mammals in the northern Chilean arid zone. *J. Biogeogr.*, 5:135-148.
- MEYER, T. 1963. Estudios sobre la Selva Tucumana: la selva de Mirtaceas de "Las Pavas". Op. Lill. 10, Inst. Miguel Lillo, Tucumán, Argentina, 144 pp.
- MEYER, T., AND W. K. WEYRAUCH. 1966. Guía para dos excursiones biológicas en la provincia de Tucumán. Univ. Nac. Tucumán, Inst. Miguel Lillo, Misc. 23:1-127.
- MINOPRIO, J. D. L. 1945. Sobre el *Chlamyphorus truncatus* Harlan. *Acta Zool. Lill.*, 3:5-58.
- MORELLO, J. 1958. La provincia fitogeográfica del Monte. Op. Lill. 2, Inst. Miguel Lillo, Tucumán, Argentina, 155 pp.
- MORELLO, J., AND J. ADÁMOLI. 1968. Las grandes unidades de vegetación y ambiente del Chaco Argentino. Primera parte: objetivos y metodología. INTA. La Vegetación de la República Argentina, 10:1-125.
- MORELLO, J., AND C. S. TOLEDO. 1959a. El bosque chaqueño. I. Paisaje primitivo, paisaje natural y paisaje cultural en el oriente de Salta. *Rev. Agron. del Noroeste Argentino*, 3:5-81.
- . 1959b. El bosque chaqueño. II. La ganadería y el bosque en el oriente de Salta. *Rev. Agron. del Noroeste Argentino*, 3:209-258.
- MORTON, S. R. 1979. Diversity of desert-dwelling mammals: a comparison of Australia and North America. *J. Mamm.*, 60:253-264.
- MÜLLER, P. 1973. The dispersal centres of terrestrial vertebrates in the Neotropical realm. *Biogeographica*, vol. 2. W. Junk Publ., The Hague, 244 pp.
- MYERS, P. 1977. A new phyllotine rodent (genus *Graomys*) from Paraguay. *Occas. Papers Mus. Zool., Univ. Michigan*, 616:1-7.
- . 1982. Origins and affinities of the mammal fauna of Paraguay. Pp. 85-93, in *Mammalian biology in South America* (M. A. Mares and H. H. Genoways, eds.), Pymatuning Lab. Ecol. Spec. Publ., 6:xii + 1-539.
- NOWAK, R. M., AND J. L. PARADISO (eds.). 1983. Walker's mammals of the world. Johns Hopkins Univ. Press, Baltimore, 4th ed., 1:lxii + 1-568 and 2:xxv + 569-1362.
- OJEDA, R. A. 1979. Aspectos ecológicos de una comunidad de cricétidos del bosque subtropical de transición. *Neotrópica*, 25:27-35.
- OJEDA, R. A., AND R. M. BARQUEZ. 1976. Sobre el efecto de ambientes inestables en micromamíferos. *Neotrópica*, 22:109-111.
- . 1978. Contribución al conocimiento de los quirópteros de Bolivia. *Neotrópica*, 24:33-38.

- OJEDA, R. A., AND M. A. MARES. 1982. Conservation of South American mammals: Argentina as a paradigm. Pp. 505-521, in *Mammalian biology in South America* (M. A. Mares and H. H. Genoways, eds.), Pymatuning Lab. Ecol. Spec. Publ., 6:xii + 1-539.
- . 1984. La degradación de los recursos naturales y la fauna silvestre en Argentina. *Interciencia*, 9:21-26.
- OLROG, C. C. 1958. Notas mastozoológicas sobre la colección del Instituto Miguel Lillo (Tucumán). *Acta Zool. Lill.*, 16:91-95.
- . 1959. Notas mastozoológicas. II. Sobre la colección del Instituto Miguel Lillo. *Acta Zool. Lill.*, 17:403-419.
- . 1976. Sobre mamíferos del noroeste Argentino. *Acta Zool. Lill.*, 32:5-14.
- . 1979. Los mamíferos de la selva húmeda, Cerro Calilegua, Jujuy. *Acta Zool. Lill.*, 33:9-14.
- OLROG, C. C., AND R. M. BARQUEZ. 1979. Dos quirópteros nuevos para la fauna Argentina. *Neotrópica*, 25:185-186.
- OLROG, C. C., AND M. M. LUCERO. 1980. Guía de los mamíferos Argentinos. Fund. Miguel Lillo, Tucumán, Argentina, 151 pp.
- OLROG, C. C., R. A. OJEDA, AND R. M. BARQUEZ. 1976. *Catagonus wagneri* (Rusconi) en el Noroeste Argentino. *Neotrópica*, 22:53-56.
- ORIAN, G. H., AND O. T. SOLBRIG (eds.). 1977. *Convergent evolution in warm deserts*. Dowden, Hutchinson and Ross, Inc., Stroudsburg, Pennsylvania, 333 pp.
- OWEN, R. D., AND W. D. WEBSTER. 1983. Morphological variation in the Ipanema bat, *Pygoderma bilabiatum*, with description of a new subspecies. *J. Mamm.*, 64:146-149.
- PASCUAL, R., AND O. ODREMAN RIVAS. 1971. Evolución de las comunidades de los vertebrados del Terciario Argentino. Los aspectos paleozoogeográficos y paleoclimáticas relacionados. *Ameghiniana*, 7:372-412.
- PATTERSON, B., AND R. PASCUAL. 1972. The fossil mammal fauna of South America. Pp. 247-309, in *Evolution, mammals, and southern continents* (A. Keast, F. C. Erk, and B. Glass, eds.), State Univ. New York Press, Albany, 543 pp.
- PEARSON, O. P. 1958. A taxonomic revision of the rodent genus *Phyllotis*. *Univ. California Publ. Zool.*, 106:117-174.
- PEARSON, O. P., AND A. K. PEARSON. 1982. Ecology and biogeography of the southern rainforests of Argentina. Pp. 129-142, in *Mammalian biology in South America* (M. A. Mares and H. H. Genoways, eds.), Pymatuning Lab. Ecol. Spec. Publ., 6:xii + 539.
- PEARSON, O. P., AND C. P. RALPH. 1978. The diversity and abundance of vertebrates along an altitudinal gradient in Perú. *Mem. Mus. Hist. Natur. "Javier Prado,"* 18:1-97.
- PIELOU, E. C. 1974. *Population and community ecology: principles and methods*. Gordon and Breach, Scientific Publishers, Inc., New York, 424 pp.
- PINE, R. H., S. D. MILLER, AND M. L. SCHAMBERGER. 1979. Contributions to the mammalogy of Chile. *Mammalia*, 43:339-376.
- POOLE, R. W. 1974. *An introduction to quantitative ecology*. McGraw-Hill, Ser. Pop. Biol., 532 pp.
- RABINOVICH, J. E., AND E. H. RAPOPORT. 1975. Geographical variation of diversity in Argentine passerine birds. *J. Biogeogr.*, 2:141-157.
- RAVEN, P. H., AND D. I. AXELROD. 1975. History of the flora and fauna of Latin America. *Amer. Sci.*, 63:420-429.
- REIG, O. A. 1964. Roedores y marsupiales del partido de General Pueyrredón y regiones adyacentes (Provincia de Buenos Aires, Argentina). *Publ. Mus. Mun. Cs. Natur. Mar del Plata*, 1:203-224.
- . 1981. Teoría del origen y desarrollo de la fauna de mamíferos de América del Sur. *Monogr. Natur. Mus. Mun. Cs. Natur. "Lorenzo Scaglia,"* Mar del Plata, Argentina, 162 pp.
- ROHLF, F. J., J. KISPAUGH, AND D. KIRK. 1982. NT-SYS. Numerical taxonomy system of multivariate statistical programs. Tech. Rept. State Univ. New York at Stony Brook.

- ROMAÑA, C., AND J. W. ABALOS. 1950. Lista de quirópteros de la colección del Instituto de Medicina Regional, y sus parásitos. *Anal. Inst. Med. Reg.*, 3:111-117.
- ROUGHGARDEN, J. 1983. Competition and theory in community ecology. *Amer. Nat.*, 122:583-601.
- SARMIENTO, G. 1975. The dry plant formations of South America and their floristic connections. *J. Biogeogr.*, 2:233-251.
- SAVAGE, J. M. 1974. The isthmian link and the evolution of Neotropical mammals. *Contrib. Sci., Nat. Hist. Mus. Los Angeles Co.*, 260:1-51.
- SCHMARDA, L. K. 1853. *Die geographische Verbreitung der Tiere*. Wien, Gerold und Sohn, 755 pp.
- SIMPSON, B. B. (ed.). 1977. *Mesquite: its biology in two desert ecosystems*. Dowden, Hutchinson and Ross, Inc., Stroudsburg, Pennsylvania, 250 pp.
- . 1979. Quaternary biogeography of the high montane regions of South America. Pp. 157-188, *in* *The South American herpetofauna: its origin, evolution, and dispersal* (W. E. Duellman, ed.), *Monogr. Mus. Nat. Hist., Univ. Kansas*, 7:1-485.
- SIMPSON, B. B., AND J. HAFFER. 1978. Speciation patterns in the Amazonian forest biota. *Ann. Rev. Ecol. Syst.*, 9:497-518.
- SIMPSON, B. B., AND F. VERVOORST. 1977. Physiographic settings of the study sites. Pp. 16-25, *in* *Convergent evolution in warm deserts* (G. H. Orians and O. T. Solbrig, eds.), Dowden, Hutchinson and Ross, Inc., Stroudsburg, Pennsylvania, 333 pp.
- SIMPSON, G. G. 1964. Species density of North American Recent mammals. *Syst. Zool.* 13:57-73.
- . 1978. Early mammals in South America: fact, controversy and mystery. *Proc. Amer. Phil. Soc.*, 5:318-328.
- SMITH, C. H. 1983a. A system of world mammal faunal regions. I. Logical and statistical derivation of the regions. *J. Biogeogr.*, 10:455-466.
- . 1983b. A system of world mammal faunal regions. II. The distance decay effect upon inter-regional affinities. *J. Biogeogr.*, 10:467-482.
- SNEATH, P. H. A., AND R. R. SOKAL. 1973. *Numerical taxonomy*. W. H. Freeman and Co., San Francisco, xv + 573 pp.
- SOLBRIG, O. T. 1976. The origin and floristic affinities of the South American temperate desert and semidesert regions. Pp. 7-49, *in* *Evolution of desert biota* (D. W. Goodall, ed.), Univ. Texas Press, Austin, 250 pp.
- SOKAL, R. R., AND F. J. ROHLF. 1969. *Biometry*. W. H. Freeman and Co., San Francisco, 776 pp.
- STREILEIN, K. E. 1982a. Ecology of small mammals in the semiarid Brazilian Caatinga. I. Climate and faunal composition. *Ann. Carnegie Mus.*, 51:79-107.
- . 1982b. Ecology of small mammals in the semiarid Brazilian Caatinga. V. Agonistic behavior and overview. *Ann. Carnegie Mus.*, 51:345-369.
- TAPIA, A. 1935. Pilcomayo. Ministerio de Agricultura de la Nación, Div. Minas y Geología Bol., 40:1-124.
- THOMAS, O. 1897. On some small mammals from Salta, N. Argentina. *Ann. Mag. Nat. Hist.*, ser. 6, 20:214-218.
- . 1912. New *Centronycteris* and *Ctenomys* from S. America. *Ann. Mag. Nat. Hist.*, ser. 8, 10:638-640.
- . 1915. On bats of the Genus *Promops*. *Ann. Mag. Nat. Hist.*, ser. 8, 16:62-64.
- . 1918. On small mammals from Salta and Jujuy collected by Mr. E. Budin. *Ann. Mag. Nat. Hist.*, ser. 9, 1:186-193.
- . 1919. Two new rodents from Tartagal, Salta, N. Argentina. *Ann. Mag. Nat. Hist.*, ser. 9, 4:154-156.
- . 1920. A further collection of mammals from Jujuy. *Ann. Mag. Nat. Hist.*, ser. 9, 5:188-196.
- . 1921. On a further collection of mammals from Jujuy obtained by Sr. E. Budin. *Ann. Mag. Nat. Hist.*, ser. 9, 8:608-617.

- TONNI, E., AND G. POLITIS. 1978. La distribución del guanaco (Mammalia, Camelidae) en la Provincia de Buenos Aires durante el Pleistoceno Tardío y Holoceno. Los factores climáticos como causas de su retracción. *Ameghiniana*, 15:53-66.
- VERVOORST, F. 1982. Noroeste. Pp. 9-24, in *Conservación de la vegetación natural en la República Argentina*. Simposio XVIII Jornadas de Bot. Fund. Miguel Lillo, Tucumán, Argentina, 127 pp.
- VILLA-R., B., AND M. V. CORNEJO. 1969. Algunos murciélagos del norte de Argentina. *Misc. Publ. Mus. Nat. Hist.*, 51:407-428.
- VUILLEUMIER, B. S. 1971. Pleistocene changes in the fauna and flora of South America. *Science*, 173:771-780.
- WALLACE, A. R. 1876. *The geographical distribution of animals*. MacMillan, London, 2 vols., 503 and 607 pp. New York: Hafner Publ. Reprint; 1962.
- WEBB, S. D. 1976. Mammalian faunal dynamics of the Great American Interchange. *Paleobiology*, 2:220-234.
- . 1978. A history of savanna vertebrates in the New World. Part II: South America and the great interchange. *Ann. Rev. Ecol. Syst.*, 9:393-426.
- WETZEL, R. M. 1977. The Chacoan peccary *Catagonus wagneri* (Rusconi). *Bull. Carnegie Mus. Nat. Hist.*, 3:1-36.
- . 1982. Systematics, distribution, ecology, and conservation of South American edentates. Pp. 345-375, in *Mammalian biology in South America* (M. A. Mares and H. H. Genoways, eds.), Pymatuning Lab. Ecol. Spec. Publ., 6:xii + 1-539.
- WETZEL, R., AND J. CRESPO. 1975. Existencia de una tercera especie de pecarí (Fam. Tayassuidae, Mammalia) en Argentina. *Rev. Mus. Argentino Cien. Nat. "Bernardino Rivadavia," Zool.*, 12:25-26.
- WETZEL, R., AND E. MONDOLFI. 1979. The subgenera and species of long-nosed armadillos, genus *Dasypus* L. Pp. 43-63, in *Vertebrate ecology in the northern Neotropics* (J. F. Eisenberg, ed.), Smithsonian Inst. Press, Washington, D.C., 271 pp.
- WILLIAMS, D. F. 1978. Taxonomic and karyologic comments on small brown bats, genus *Eptesicus*, from South America. *Ann. Carnegie Mus.*, 47:361-383.
- WILLIAMS, D. F., AND M. A. MARES. 1978. A new genus and species of phyllotine rodent (Mammalia: Muridae) from northwestern Argentina. *Ann. Carnegie Mus.*, 47:193-221.
- WILLIG, M. R. 1983. Composition, microgeographic variation, and sexual dimorphism in Caatingas and Cerrado bat communities from northeast Brazil. *Bull. Carnegie Mus. Nat. Hist.*, 23:1-131.
- WILSON, D. E. 1973. Bat faunas: a trophic comparison. *Syst. Zool.*, 22:14-29.
- WILSON, J. W. 1974. Analytical zoogeography of North American mammals. *Evolution*, 28:124-140.
- YEPES, J. 1929. Notas sobre la distribución geográfica del pichi ciego menor (*Chlamyphorus truncatus*) y pichi llorón (*Chaetophractus vellerosus*). *Physis*, 9:439-446.
- . 1933a. Una especie nueva de "mulita" (Dasipodinae) para el norte Argentino. *Physis*, 11:225-232.
- . 1933b. Nuevos roedores para la fauna Argentina. *Rev. Chilena Hist. Nat.*, 37:46-49.
- . 1936. Mamíferos coleccionados en la parte central y occidental de la Provincia de La Rioja. *Physis*, 12:31-42.
- . 1939. Una nueva subespecie de "pichi ciego" mayor (Chlamyphorinae) y su probable distribución geográfica. *Physis*, 16:35-39.
- . 1942. Nuevas localidades para el chos-chos cordillerano (*Octodontomys gliroides*). *Rev. Argentino Zoogeogr.*, 1:195-196.
- . 1944. Comentario sobre cién localidades nuevas para mamíferos sudamericanos. *Rev. Argentino Zoogeogr.*, 4:59-71.

Address of authors: R. A. OJEDA, *Department of Biological Sciences, University of Pittsburgh, Pittsburgh, Pennsylvania 15260* (present address: *Instituto Argentino de Investigaciones de Zonas Áridas, C. C. 507, Mendoza (5500), Argentina*); M. A. MARES, *Oklahoma Museum of Natural History and Department of Zoology, University of Oklahoma, Norman, Oklahoma 73019*. Received 5 June 1986; accepted 6 April 1987.

TEXAS TECH UNIVERSITY PRESS

SELECTED TITLES IN MAMMALOLOGY

Special Publications, The Museum (ISSN 0119-1768)

- No. 1 Gardner, A. L. 1973. The systematics of the genus *Didelphis* (Marsupialia: Didelphidae) in North and Middle America. 81 pp. \$1.00.
- No. 5 Genoways, H. H. 1973. Systematics and evolutionary relationships of pine pocket mice, genus *Peromyscus*. 368 pp. \$10.00.
- No. 10 Baker, R. J., J. K. Jones, Jr., and D. C. Carter, eds. 1976. Biology of bats of the New World Phyllostomatidae. Part I. 218 pp. \$8.00.
- No. 13 Baker, R. J., J. K. Jones, Jr., and D. C. Carter, eds. 1977. Biology of bats of the New World Phyllostomatidae. Part II. 361 pp. \$16.00.
- No. 16 Baker, R. J., J. K. Jones, Jr., and D. C. Carter, eds. 1979. Biology of bats of the New World Phyllostomatidae. Part III. 111 pp. \$20.00.
- No. 22 Martin, R. E., and B. R. Chapman. 1981. Contributions in mammalogy in honor of Robert L. Packard. 231 pp. \$25.00 (paper); \$50.00 (cloth).
- No. 24 Mason, J. O., and R. H. Baker. 1986. Mammals of Zacatecas. 88 pp. \$18.00 (paper); \$38.00 (cloth).
- No. 26 Owen, R. D. 1987. Phylogenetic analyses of the bat subfamily Stenodermatinae (Mammalia: Chiroptera). 65 pp. \$15.00 (paper); \$30.00 (cloth).
- No. 27 Ojeda, R. A., and M. A. Mares. 1989. A biogeographic analysis of the mammals of Salta Province, Argentina: patterns of species assemblage in the Neotropics. 66 pp. \$12.00 (paper).

Occasional Papers, The Museum (ISSN 0119-175X)

- No. 3 Genoways, H. H., and J. K. Jones, Jr. 1972. Variation and ecology in a local population of the vesper mouse (*Nyctomys sumichrasti*). 22 pp.
- No. 13 Jones, J. K., Jr., J. D. Smith, and H. H. Genoways. 1973. Annotated checklist of mammals of the Yucatan Peninsula, Mexico. I. Chiroptera. 31 pp.
- No. 22 Jones, J. K., Jr., H. H. Genoways, and T. F. Lawlor. 1974. Annotated checklist of mammals of the Yucatan Peninsula, Mexico. II. Rodentia. 24 pp.
- No. 23 Jones, J. K., Jr., H. H. Genoways, and J. D. Smith. 1974. Annotated checklist of mammals of the Yucatan Peninsula, Mexico. III. Marsupialia, Insectivora, Primates, Edentata, Lagomorpha. 12 pp.
- No. 26 Genoways, H. H., and J. K. Jones, Jr. 1975. Annotated checklist of mammals of the Yucatan Peninsula, Mexico. IV. Carnivora, Sirenia, Perissodactyla, Artiodactyla. 22 pp.
- No. 33 Fulk, G. W. 1975. Population ecology of rodents in the semiarid shrublands of Chile. 10 pp.
- No. 68 Webster, W. D., and J. K. Jones, Jr. 1980. Noteworthy records of bats from Bolivia. 6 pp.
- No. 70 Davis, W. B. 1980. New *Stumira* (Chiroptera: Phyllostomatidae) from Central and South America, with key to currently recognized species. 5 pp.
- No. 79 Glass, B. P., and C. da Encarnacao. 1982. On the bats of western Minas Gerais, Brazil. 8 pp.
- No. 82 Jones, J. K., Jr., and T. L. Yates. 1983. Review of the white-footed mice, genus *Peromyscus*, of Nicaragua. 15 pp.
- No. 93 Davis, W. B. 1984. Review of the large fruit-eating bats of the *Artibeus "lituratus"* complex (Chiroptera: Phyllostomatidae) in Middle America. 16 pp.
- No. 94 Baker, R. J., J. A. Groen, and R. D. Owen. 1984. Field key to American bats. 18 pp.
- No. 103 Engstrom, M., and J. K. Jones, Jr. 1986. Synopsis of the tree rats of Nicaragua. 23 pp.
- No. 106 Jones, J. K., Jr., and R. Owen. 1986. Checklist and bibliography of Nicaraguan Chiroptera. 13 pp.
- No. 125 Baker, R. J., C. G. Dunn, and K. Nelson. 1988. Allozyme study of the relationships of *Phylloderma* and four species of *Phyllostomus*. 11 pp.

Copies of Special Publications may be purchased on standing order or by individual title. The Occasional Papers are available by subscription (\$16.00 per year for individuals, \$19.00 for institutions; add \$3.00 for mailing outside North America) or by individual titles (\$2.00 each). Postage (\$2 first title, \$0.75 each thereafter) should be included. Press pays postage on prepaid orders of 5 or more titles.

*Please direct orders or requests for a complete list of titles to:
Texas Tech University Press, Sales Office, Lubbock, Texas 79409-1037, USA*

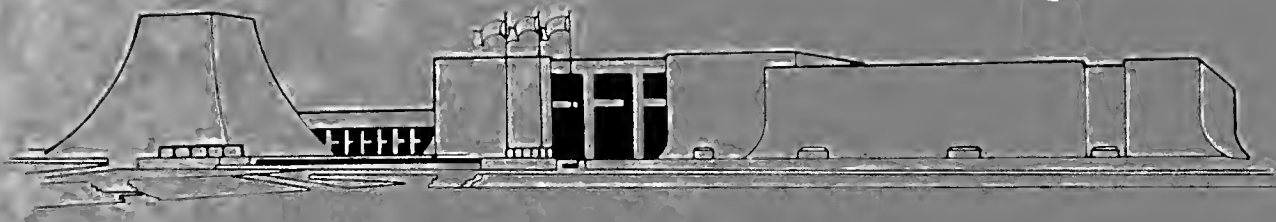

TEXAS TECH UNIVERSITY PRESS

ISBN 0-89672-172-

MCZ ERNST MAYR LIBRARY



3 2044 128 447 455

